



Nova-227 Outdoor LTE TDD eNodeB Installation Guide

P/N: 1701000123

Version: 01

About This Document

This document is a guidance of Nova-227 hardware installation for installation personnel, including the preparation of installation tools and supporting materials, the demands for installation environment, installation procedure, cable connection and power on.

Accomplish the installation of the device according to this guide, the installation personnel can avoid potential damage to the device during the installation procedure, which makes sure the subsequent good running of the device.

This document suit for the models of pBS2120 and pBS1100x series eNodeBs.

Copyright Notice

Baicells copyrights this specification. No part of this specification may be reproduced in any form or means, without the prior written consent of Baicells.

Disclaimer

This specification is preliminary and is subject to change at any time without notice. Baicells assumes no responsibility for any errors contained herein. For more information, please consult our technical engineers.



Disposal of Electronic and Electrical Waste

Pursuant to the WEEE EU Directive, electronic and electrical waste must not be disposed of with unsorted waste. Please contact your local recycling authority for disposal of this product.

Revision Record

Date	Version	Description
2 March, 2020	01	Initial Released of new logo.

Contact Us

Baicells Technologies Co., Ltd.

Address: 10-11F, Bldg. A1, No.1 Zhongguancun, Yongfeng Industrial Base, Haidian Dist., Beijing, China

E-mail: support@baicells.com
support_na@baicells.com

Website: <http://www.baicells.com/>

1. Product Overview

1.1 Introduction

Baicells Nova-227 is high performance outdoor micro eNodeB based on TDD LTE technology, which is developed by Baicells. The Nova-227 supports wired backhaul connections to backbone networks, and provides LTE access to user terminals, implemented voice and data service transmissions.

The Nova-227 makes use of the current transmission resources to reduce the operator's investment, implement the low-cost construction of LTE networks and enhance indoor coverage, thereby providing high-speed broadband access for users in assembly occupations.

The Nova-227 can be widely used by telecom operators, broadband operators, and enterprises, etc.

1.2 Features

- Adopt the integration design of baseband and RF, flexible to deploy.
- Based on 3GPP international standard LTE TDD technology; provide high speed data service; support a maximum transfer rate of DL: 110Mbit/s, UL: 14Mbit/s with 20MHz spectrum.
- Support flexible uplink and downlink time slot ratio: 0(3:1), 1(2:2), 2(1:3), and high speed data transmission.
- Support 5MHz/10MHz/15MHz/20MHz operation bandwidth.
- Support internal antenna and GPS.
- Support PoE+ power supply, only one Ethernet cable realize data transmission and power supply.
- Security services to provide timely protection against potential security risks and illegal intrusion.
- Support simple and convenient local and remote web management.
- Integration as required, easy to installation and deployment, accurate coverage and improved network capacity.
- Support network management functions, which includes the management, monitoring and maintenance.

1.3 Appearance

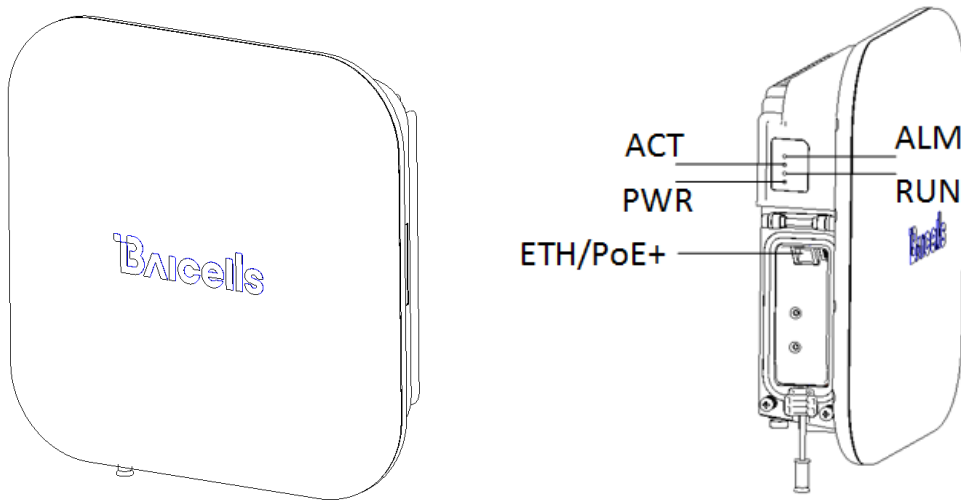

Table 1-1 Nova-227 Interface Description

Interface Name	Description
ETH/PoE+	RJ-45 interface, used for data configuration or data backhaul, and PoE+ power supply.

Table 1-2 Nova-227 Interface Indicators

Identity	Color	Status	Description
PWR	Green	Steady On	Power On
		OFF	No Power Supply
ACT	Green	Steady On	The cell is activated.
		OFF	The cell is not activated.
RUN	Green	Fast flash: 0.125s on, 0.125s off	The board is loading.
		Slow flash: 1s on, 1s off	The board is normal.
		OFF	No power input or board fault
ALM	Red	Steady On	Hardware alarm, e.g. VSWR alarm
		OFF	No alarm

1.4 Technical Specification

1.4.1 Hardware Specification

Item	Description
LTE Mode	LTE TDD
LTE Bands	Band38/39/40/41/42/43/48
Channel Bandwidth*	5/10/15/20 MHz
Output Power	24 ± 2dBm/Ant
Receive Sensitivity	-100 dBm @band42/43/48 -101 dBm @band38/39/40/41
Synchronization	GPS
Backhaul	1 x RJ-45 Ethernet interface (1 GE)
MIMO	DL: 2 x 2
Dimension	248mm (H) x 248mm (W) x 80mm (D)
Installation Type	Pole, wall
Antenna	13dBi, internal high gain antenna Horizontal beam width 65°, vertical beam width 20° Polarization mode: ±45°
Overall Power	< 20 W
Power Supply	PoE+, IEEE802.3at standard
Weight	About 2.0 kg

* The model pBS2120 only support 10MHz/20MHz.

Note: The test method of receiving sensitivity is proposed by the 3GPP TS 36.104, which is based on 5MHz bandwidth, FRC A1-3 in Annex A.1 (QPSK, R=1/3, 25RB) standard.

1.4.2 Software Specification

Item	Description
LTE Standard	3GPP Release 9
Peak Rate	<ul style="list-style-type: none"> • 20 MHz: <ul style="list-style-type: none"> SA0: DL 50 Mbps, UL 42 Mbps SA1: DL 80 Mbps, UL 28 Mbps SA2: DL 110 Mbps, UL 14 Mbps • 10MHz: <ul style="list-style-type: none"> SA0: DL 25 Mbps, UL 21 Mbps SA1: DL 40 Mbps, UL 14 Mbps SA2: DL 55 Mbps, UL 7 Mbps
User Capacity	32 concurrent users
QoS Control	3GPP standard QCI

Item	Description
Modulation	UL: QPSK, 16QAM, 64QAM DL: QPSK, 16QAM, 64QAM
Voice Solution	CSFB, VoLTE, eSRVCC
Traffic Offload	LIPA (Local IP Access) SIPTO (Selected IP Traffic Offload)
SON	Automatic setup ANR (Automatic Neighbor Relation) PCI confliction detection
Spectrum Scanning	Supported
UL Interference Detection	Supported
RAN Sharing	Supported
Network Management Interface	Support TR069 interface protocol
MTBF	≥ 150000 hours
MTTR	≤ 1 hour
Maintenance	Support remote/local maintenance, based on SSH protocol
	Support remote maintenance
	Support online status management
	Support performance statistics
	Support failure management
	Support configuration management
	Support local or remote software upgrading and loading
	Support log
	Support connectivity diagnosis
	Support automatic start and configuration
	Support alarm reporting
	Support KPI Recording
	Support user information tracing
Support signaling trace	

1.4.3 Environment Specification

Item	Description
Operating Temperature	-40°C to 55°C
Storage Temperature	-45°C to 70°C
Humidity	5% to 95%
Atmospheric Pressure	70kPa to 106kPa
IP Protection Grade	IP66

2. Installation Guide

2.1 Installation Preparation

2.1.1 Supporting Materials

Item	Description
Ethernet cable	Outdoor CAT6, Shorter than 100m (330 ft)
Ground cable	16mm ² yellow-green wire

2.1.2 Installation Environment

2.1.2.1 Locational Requirements

Environments with high-temperatures, harmful gases, unstable voltages, volatile vibrations, loud noises, flames, explosives, and electromagnetic interference (large radar stations, transmitting stations, transformer substations) are not suitable for the operation of Nova-227, and thus should be avoided.

Places prone to have impounded water, soaking, leakage, or condensation, should also be avoided.

Factors like climate, hydrology, geology, earthquake, electric power, and transportation should be taken into consideration in the construction process so that a proper location can be chosen to meet the communication engineering environmental requirements, as well as the technical requirements of network planning and communication equipment.

2.1.2.2 Environmental Requirements

Item	Range
Operating Temperature	-40°C to 55°C
Relative humidity (no condensation)	5% to 95%

2.1.2.3 Personnel Requirements

The installation personnel must master the basic safe operation knowledge, through the training, and having the corresponding qualifications.

2.2 Install on Pole

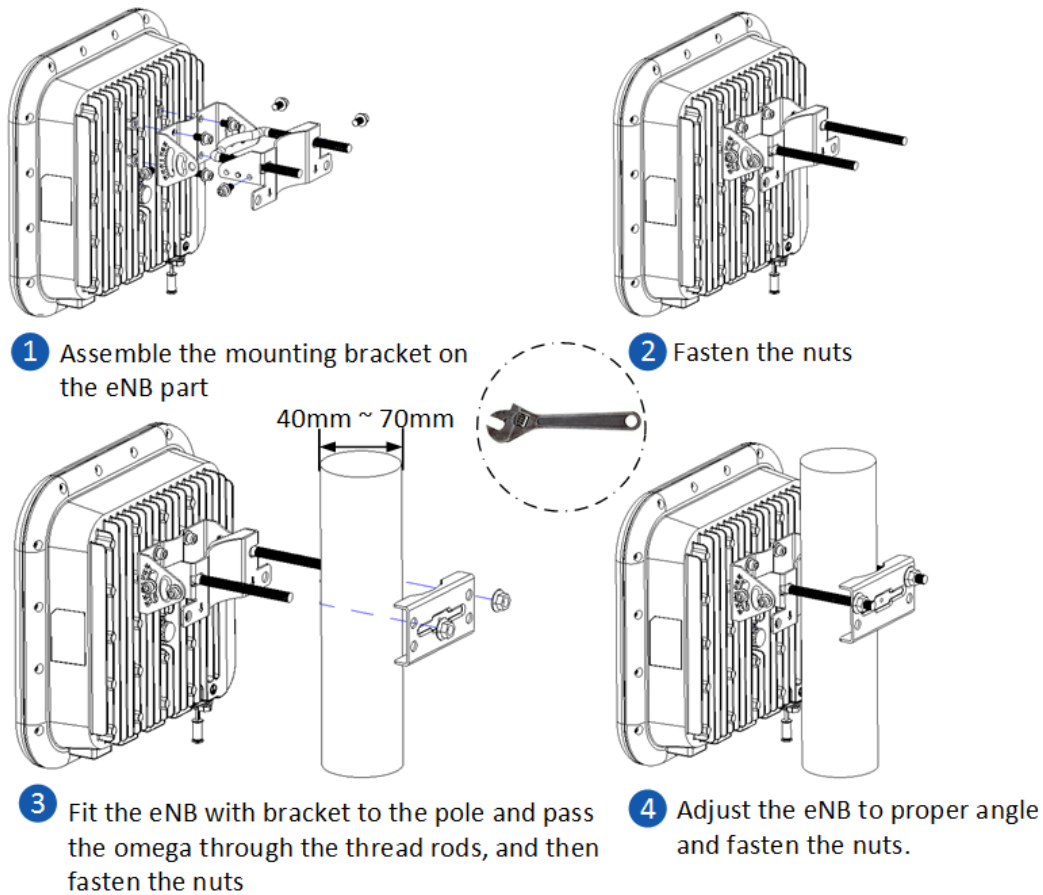

2.3 Install on Wall

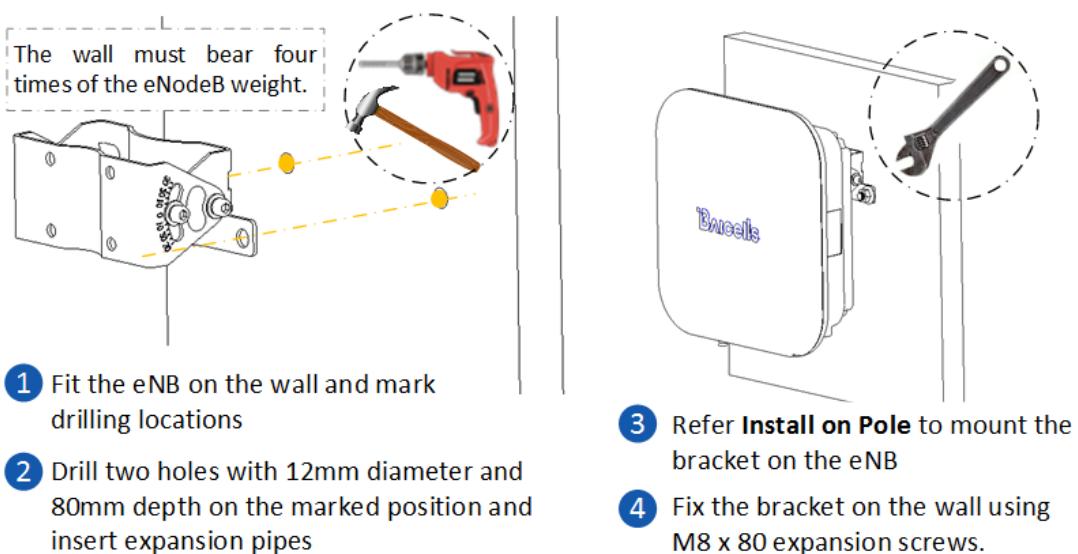

Note: According to the situation of the installation site, the angle of the eNodeB can be adjusted.

2.4 Connect Cable

Before connect cables, unscrew the three screws on the cover of wiring cavity using M4 cross screwdriver and open the wiring cavity.

After complete the connection, close the cover and fasten screws.

Note: If the base station need to debug, connect the LAN interface to PC first and configure the IP address of the PC with 192.168.150.x.

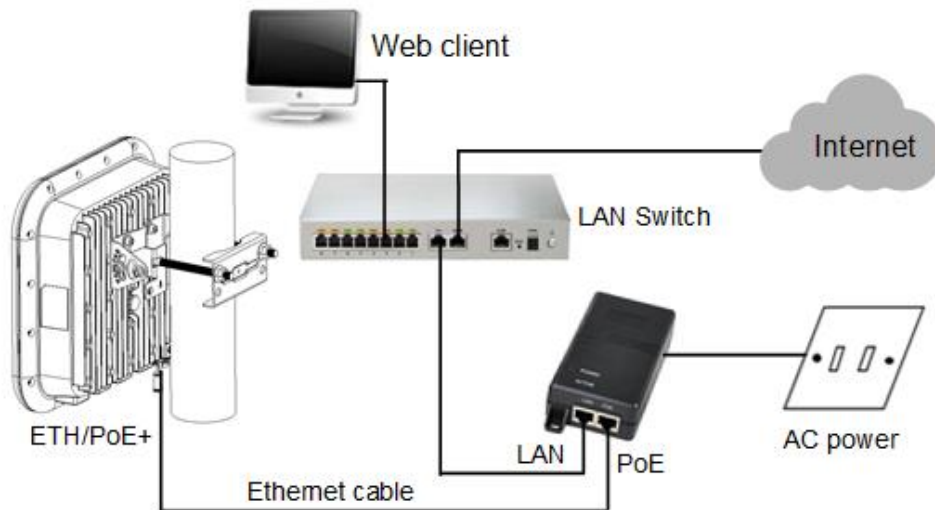

2.5 Connect Ground Cable

CAUTION:

It is unlikely to happen but since the LTE eNodeB is a kind of very sophisticated equipment, so it is recommended to test it on the ground to make sure everything is functioning before install on the tower.

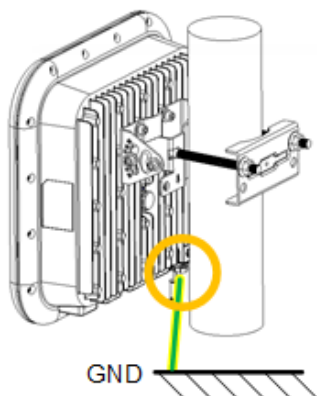

- 1 Unscrew the grounding screw (at the bottom of the eNB), connect one end of the grounding cable to the screw, and fasten it again.
- 2 The other end of the ground cable needs to connect to a good grounding point.

2.6 Power ON

After the Nove-227 is powered on, indicators can hint the status of the eNodeB.

Appendix A Regulatory Compliance

Only apply to the model pBS2120.

FCC Compliance

This device complies with part 15 of the FCC Rules. Operation is subject to the following two conditions: (1) This device may not cause harmful interference, and (2) this device must accept any interference received, including interference that may cause undesired operation.

Any Changes or modifications not expressly approved by the party responsible for compliance could void the user's authority to operate the equipment.

This equipment has been tested and found to comply with the limits for a Class B digital device, pursuant to part 15 of the FCC Rules. These limits are designed to provide reasonable protection against harmful interference in a residential installation. This equipment generates uses and can radiate radio frequency energy and, if not installed and used in accordance with the instructions, may cause harmful interference to radio communications. However, there is no guarantee that interference will not occur in a particular installation. If this equipment does cause harmful interference to radio or television reception, which can be determined by turning the equipment off and on, the user is encouraged to try to correct the interference by one or more of the following measures:

- Reorient or relocate the receiving antenna.
- Increase the separation between the equipment and receiver.
- Connect the equipment into an outlet on a circuit different from that to which the receiver is connected.
- Consult the dealer or an experienced radio/TV technician for help.

Warning:

This equipment complies with FCC radiation exposure limits set forth for an uncontrolled environment. This equipment should be installed and operated with minimum distance 30cm between the radiator & your body.