

# FCC/IC REPORT

**Applicant:** Baicells Technologies Co., Ltd.

**Address of Applicant:** 3F, Hui Yuan Development Building, No.1 Shangdi Information Industry Base, Haidian Dist., Beijing, China

**Equipment Under Test (EUT)**

Product Name: LTE-TDD Base Station

Model No.: pBS11004

Trade mark: BaiCells

**FCC ID:** 2AG32PBS11004

**Canada IC:** 20982-PBS11004

**Applicable standards:** FCC CFR Title 47 Part 2  
FCC CFR Title 47 Part 27 Subpart M  
RSS-Gen Issue 4 November 2014  
RSS-199 Issue 3 December 2016

**Date of sample receipt:** 17 Jan., 2018

**Date of Test:** 17 Jan., to 23 Jan., 2018

**Date of report issued:** 23 Jan., 2018

**Test Result:** PASS\*

\* In the configuration tested, the EUT complied with the standards specified above.

Authorized Signature:



Bruce Zhang  
Laboratory Manager

This report details the results of the testing carried out on one sample. The results contained in this test report do not relate to other samples of the same product and does not permit the use of the CCIS product certification mark. The manufacturer should ensure that all products in series production are in conformity with the product sample detailed in this report.

This report may only be reproduced and distributed in full. If the product in this report is used in any configuration other than that detailed in the report, the manufacturer must ensure the new system complies with all relevant standards.

This document cannot be reproduced except in full, without prior written approval of the Company. Any unauthorized alteration, forgery or falsification of the content or appearance of this document is unlawful and offenders may be prosecuted to the fullest extent of the law. Unless otherwise stated the results shown in this test report refer only to the sample(s) tested and such sample(s) are retained for 90 days only.

## 2. Version

Version No.	Date	Description
00	23 Jan., 2018	Original

**Tested by:**

  
\_\_\_\_\_  
**Test Engineer**

**Date:**

23 Jan., 2018

**Reviewed by:**

  
\_\_\_\_\_  
**Project Engineer**

**Date:**

23 Jan., 2018

### 3. Contents

Page

<b>1. COVER PAGE</b> .....	<b>1</b>
<b>2. VERSION</b> .....	<b>2</b>
<b>3. CONTENTS</b> .....	<b>3</b>
<b>4. TEST SUMMARY</b> .....	<b>4</b>
<b>5. GENERAL INFORMATION</b> .....	<b>5</b>
5.1 CLIENT INFORMATION.....	5
5.2 GENERAL DESCRIPTION OF E.U.T.....	5
5.3 TEST ENVIRONMENT AND MODE.....	6
5.4 DESCRIPTION OF SUPPORT UNITS.....	6
5.5 MEASUREMENT UNCERTAINTY.....	6
5.6 RELATED SUBMITTAL(S) / GRANT (S).....	6
5.7 LABORATORY FACILITY.....	6
5.8 LABORATORY LOCATION.....	7
5.9 TEST INSTRUMENTS LIST.....	7
<b>6. TEST RESULTS</b> .....	<b>8</b>
6.1 TRANSMIT OUTPUT POWER.....	8
6.2 PEAK-TO-AVERAGE RATIO.....	19
6.3 OCCUPY BANDWIDTH.....	24
6.4 OUT OF BAND EMISSION AT ANTENNA TERMINALS.....	35
6.5 FIELD STRENGTH OF SPURIOUS RADIATION MEASUREMENT.....	68
6.6 FREQUENCY STABILITY V.S. TEMPERATURE MEASUREMENT.....	72
6.7 FREQUENCY STABILITY V.S. VOLTAGE MEASUREMENT.....	75
<b>7 TEST SETUP PHOTO</b> .....	<b>78</b>
<b>8 EUT CONSTRUCTIONAL DETAILS</b> .....	<b>79</b>

## 4. Test Summary

Test Item	Standard Terms	Result
RF Output Power	Part 2.1046 Part 27.50 (h)(1)(i) RSS-Gen Section 6.12 RSS-199 Section 4.4	Pass
Peak-to-Average Ratio	RSS-199 Section 4.4	Pass
Modulation Characteristics	Part 2.1047 RSS-199 Section 4.1	Pass
99% & -26 dB Occupied Bandwidth	Part 2.1049 Part 27.53(m)(6) RSS-Gen Section 6.6 RSS-199 Section 4.2	Pass
Spurious Emissions at Antenna Terminal	Part 2.1051 Part 27.53(m)(2) RSS-Gen Section 6.13 RSS-199 Section 4.5(a)	Pass
Field Strength of Spurious Radiation	Part 2.1051 Part 27.53(m)(2) RSS-Gen Section 6.13 RSS-199 Section 4.5(a)	Pass
Frequency stability vs. temperature	Part 2.1055(a)(1)(b) Part 27.54 RSS-Gen section 6.11 RSS-199 Section 4.3	Pass
Frequency stability vs. voltage	Part 2.1055(d)(1)(2) Part 27.54 RSS-Gen section 6.11 RSS-199 Section 4.3	Pass

Pass: The EUT complies with the essential requirements in the standard.

## 5. General Information

### 5.1 Client Information

Applicant:	Baicells Technologies Co., Ltd.
Address:	3F, Hui Yuan Development Building, No.1 Shangdi Information Industry Base, Haidian Dist., Beijing, China
Manufacturer:	Baicells Technologies Co., Ltd.
Address:	3F, Hui Yuan Development Building, No.1 Shangdi Information Industry Base, Haidian Dist., Beijing, China

### 5.2 General Description of E.U.T.

Product Name:	LTE-TDD Base Station
Model No.:	pBS11004
Operation Frequency range:	FCC: 2501MHz~2685MHz IC: 2575MHz~2615MHz
Modulation type:	QPSK, 16QAM, 64QAM
Antenna type:	Internal antenna
Antenna gain:	9 dBi
Power supply:	DC 48V
AC adapter:	Model: VX-PI1000GB Input: AC100-240V, 50/60Hz, 0.6A Output: DC 48V, 0.5A

#### Test Channel:

FCC		IC	
10MHz		10MHz	
Channel:	Frequency (MHz)	Channel:	Frequency (MHz)
Lowest	2501.0	Lowest	2575.0
Middle	2593.0	Middle	2595.0
Highest	2685.0	Highest	2615.0
20MHz		20MHz	
Channel:	Frequency (MHz)	Channel:	Frequency (MHz)
Lowest	2506.0	Lowest	2580.0
Middle	2593.0	Middle	2595.0
Highest	2680.0	Highest	2610.0

### 5.3 Test environment and mode

Operating Environment:	
Temperature:	Normal: 15°C ~ 35°C, Extreme: -30°C ~ +50°C
Humidity:	20 % ~ 75 % RH
Atmospheric Pressure:	1008 mbar
Voltage:	Nominal: 120Vac, Extreme: Low 102Vac, High 138Vac
Test mode:	
QPSK mode	Keep the EUT communication with simulated station in QPSK mode
16-QAM mode	Keep the EUT communication with simulated station in 16-QAM mode
64-QAM mode	Keep the EUT communication with simulated station in 64-QAM mode
Remark:	
<ol style="list-style-type: none"> <li>The EUT has been tested under continuous transmitting mode. Channel Low, Mid and High for each type band with rated data rate were chosen for full testing. The field strength of spurious radiation emission was measured as EUT stand-up position (H mode) and lie down position (E1, E2 mode) for these modes with power adaptor, earphone and Data cable. Just the worst case position (H mode) shown in report.</li> <li>Pre-scan all modulation mode (QPSK, 16QAM, 64QAM), and found the QPSK and 64QAM modulation mode are the worst case. So the worst case shown in report.</li> </ol>	

### 5.4 Description of Support Units

Test Equipment	Manufacturer	Model No.	Serial No.
/	/	/	/

### 5.5 Measurement Uncertainty

Parameters	Expanded Uncertainty
Radiated Emission (9kHz ~ 30MHz)	4.24 dB (k=2)
Radiated Emission (30MHz ~ 1000MHz)	4.35 dB (k=2)
Radiated Emission (1GHz ~ 18GHz)	4.44 dB (k=2)
Radiated Emission (18GHz ~ 26.5GHz)	4.56 dB (k=2)

### 5.6 Related Submittal(s) / Grant (s)

This is an original grant, no related submittals and grants.
--------------------------------------------------------------

### 5.7 Laboratory Facility

<p>The test facility is recognized, certified, or accredited by the following organizations:</p> <ul style="list-style-type: none"> <li> <b>FCC - Registration No.: 727551</b>            Shenzhen Zhongjian Nanfang Testing Co., Ltd. has been accredited as a testing laboratory by FCC (Federal Communications Commission). The Registration No. is 727551.         </li> <li> <b>IC - Registration No.: 10106A-1</b>            The 3m Semi-anechoic chamber of Shenzhen Zhongjian Nanfang Testing Co., Ltd. has been Registered by Certification and Engineering Bureau of Industry Canada for radio equipment testing with Registration No.: 10106A-1.         </li> <li> <b>CNAS - Registration No.: CNAS L6048</b>            Shenzhen Zhongjian Nanfang Testing Co., Ltd. is accredited to ISO/IEC 17025:2005 General Requirements for the Competence of Testing and Calibration laboratories for the competence of testing. The Registration No. is CNAS L6048.         </li> <li> <b>A2LA - Registration No.: 4346.01</b>            This laboratory is accredited in accordance with the recognized International Standard ISO/IEC 17025:2005 General requirements for the competence of testing and calibration laboratories. The test scope can be found as below link: <a href="https://portal.a2la.org/scopepdf/4346-01.pdf">https://portal.a2la.org/scopepdf/4346-01.pdf</a> </li> </ul>
---------------------------------------------------------------------------------------------------------------------------------------------------------------------------------------------------------------------------------------------------------------------------------------------------------------------------------------------------------------------------------------------------------------------------------------------------------------------------------------------------------------------------------------------------------------------------------------------------------------------------------------------------------------------------------------------------------------------------------------------------------------------------------------------------------------------------------------------------------------------------------------------------------------------------------------------------------------------------------------------------------------------------------------------------------------------------------------------------------------------------------------------------------------------------------------------------------------------------------------------------------------------------------------------------------------------------------------------------------------------------------------------------------------------------

## 5.8 Laboratory Location

Shenzhen Zhongjian Nanfang Testing Co., Ltd.  
 Address: No. B-C, 1/F., Building 2, Laodong No.2 Industrial Park, Xixiang Road,  
 Bao'an District, Shenzhen, Guangdong, China  
 Tel: +86-755-23118282, Fax: +86-755-23116366  
 Email: info@ccis-cb.com, Website: http://www.ccis-cb.com

## 5.9 Test Instruments list

Test Equipment	Manufacturer	Model No.	Serial No.	Cal. Date (mm-dd-yy)	Cal. Due date (mm-dd-yy)
3m SAC	SAEMC	9m*6m*6m	966	07-22-2017	07-21-2020
BiConiLog Antenna	SCHWARZBECK	VULB9163	497	02-25-2017	02-24-2018
Biconical Antenna	SCHWARZBECK	VUBA9117	359	06-22-2017	06-21-2018
Horn Antenna	SCHWARZBECK	BBHA9120D	916	02-25-2017	02-24-2018
Horn Antenna	SCHWARZBECK	BBHA9120D	1805	02-25-2017	02-24-2018
EMI Test Software	AUDIX	E3	6.110919b	N/A	N/A
Pre-amplifier	HP	8447D	2944A09358	02-25-2017	02-24-2018
Pre-amplifier	CD	PAP-1G18	11804	02-25-2017	02-24-2018
Spectrum analyzer	Rohde & Schwarz	FSP30	101454	02-25-2017	02-24-2018
EMI Test Receiver	Rohde & Schwarz	ESRP7	101070	02-25-2017	02-24-2018
Spectrum Analyzer	Agilent	N9020A	MY50510123	10-29-2017	10-28-2018
Signal Generator	Rohde & Schwarz	SMX	835454/016	02-25-2017	02-24-2018
Signal Generator	R&S	SMR20	1008100050	02-25-2017	02-24-2018
RF Switch Unit	MWRFTST	MW200	N/A	N/A	N/A
Cable	ZDECL	Z108-NJ-NJ-81	1608458	02-25-2017	02-24-2018
Cable	MICRO-COAX	MFR64639	K10742-5	02-25-2017	02-24-2018
Cable	SUHNER	SUCOFLEX100	58193/4PE	02-25-2017	02-24-2018
DC Power Supply	XinNuoEr	WYK-10020K	1409050110020	10-31-2017	10-30-2018
Temperature Humidity Chamber	HengPu	HPGDS-500	20140828008	09-24-2017	09-23-2018
Simulated Station	Rohde & Schwarz	CMW500	140493	06-24-2017	06-23-2018

## 6. Test Results

### 6.1 Transmit Output Power

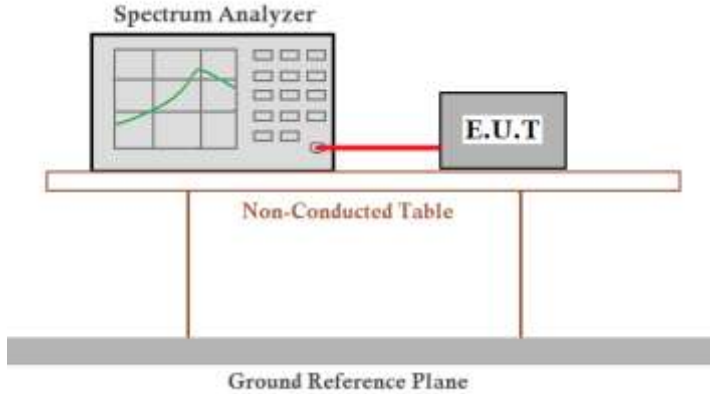
Test Requirement:	FCC Part 27.50 (h)(1)(i) and RSS-199 Section 4.4
Test Method:	ANSI/TIA-603-D 2010, FCC Part 2.1046 and RSS-Gen Section 6.12
Limit:	<p>FCC:            (1) Main, booster and base stations. (i) The maximum EIRP of a main, booster or base station shall not exceed <math>33 \text{ dBW} + 10\log(X/Y) \text{ dBW}</math>, where X is the actual channel width in MHz and Y is either 6 MHz if prior to transition or the station is in the MBS following transition or 5.5 MHz if the station is in the LBS and UBS following transition, except as provided in paragraph (h) (1)(ii) of this section.</p> <p>IC:            For base station equipment, refer to SRSP-517 for the maximum permissible e.i.r.p. (Fixed and base stations (except fixed subscriber stations) are limited to a maximum permissible equivalent isotropically radiated power (e.i.r.p.) of 1640 W/MHz (i.e. no more than 1640 W e.i.r.p. in any 1 MHz band segment) with an antenna height above average terrain (HAAT)<sup>7</sup> up to 300 metres.).</p>
Test setup:	 <p>The diagram illustrates the test setup. A Spectrum Analyzer is connected to an E.U.T. (Equipment Under Test) via a red cable. Both are placed on a Non-Conducted Table, which is supported by two legs. Below the table is a Ground Reference Plane.</p>
Test Procedure:	RBW=1MHz, VBW=3MHz, Detector mode= RMS , Trace mode: Power averaging over 100 sweeps
Test Instruments:	Refer to section 5.9 for details
Test mode:	Refer to section 5.3 for details
Test results:	Passed



**For FCC measurement data:**

Test Channel	Bandwidth (MHz)	Modulation	Ant. Port	Output Power (dBm)	Total Power (dBm)	Ant. Gain (dBi)	EIRP (dBm)	EIRP Limit (dBm)
Lowest	10	QPSK	Ant 0	23.74	26.60	12	38.60	65.22
			Ant 1	23.44				
		64QAM	Ant 0	23.65	26.55	12	38.55	
			Ant 1	23.43				
Middle	10	QPSK	Ant 0	23.32	26.37	12	38.37	65.22
			Ant 1	23.39				
		64QAM	Ant 0	23.42	26.33	12	38.33	
			Ant 1	23.22				
Highest	10	QPSK	Ant 0	23.45	26.39	12	38.39	65.22
			Ant 1	23.30				
		64QAM	Ant 0	23.29	26.32	12	38.32	
			Ant 1	23.32				
Lowest	20	QPSK	Ant 0	23.75	26.57	12	38.57	68.23
			Ant 1	23.36				
		64QAM	Ant 0	23.53	26.52	12	38.52	
			Ant 1	23.49				
Middle	20	QPSK	Ant 0	23.24	26.29	12	38.29	68.23
			Ant 1	23.32				
		64QAM	Ant 0	23.27	26.41	12	38.41	
			Ant 1	23.53				
Highest	20	QPSK	Ant 0	23.31	26.38	12	38.38	68.23
			Ant 1	23.43				
		64QAM	Ant 0	23.20	26.25	12	38.25	
			Ant 1	23.27				
<p><i>Remark:</i>            1. Directional gain = <math>G_{ANT} + 10 \log(N_{ANT})</math> dBi = <math>9 + 10 \log(2)</math> dBi = 12dBi.</p>								

**For IC measurement data:**

Test Frequency (MHz)	Bandwidth (MHz)	Modulation	Ant. Port	Output Power (dBm)	Total Power (dBm)	Ant. Gain (dBi)	EIRP (dBm)	EIRP Limit (dBm)
Lowest	10	QPSK	Ant 0	23.49	26.39	12	38.39	72.15
			Ant 1	23.26				
		64QAM	Ant 0	23.43	26.34	12	38.34	
			Ant 1	23.22				
Middle	10	QPSK	Ant 0	23.31	26.32	12	38.32	72.15
			Ant 1	23.31				
		64QAM	Ant 0	23.20	26.23	12	38.23	
			Ant 1	23.24				
Highest	10	QPSK	Ant 0	23.23	26.26	12	38.26	72.15
			Ant 1	23.26				
		64QAM	Ant 0	23.25	26.27	12	38.27	
			Ant 1	23.27				
Lowest	20	QPSK	Ant 0	23.39	26.38	12	38.38	75.16
			Ant 1	23.35				
		64QAM	Ant 0	23.40	26.35	12	38.35	
			Ant 1	23.28				
Middle	20	QPSK	Ant 0	23.28	26.31	12	38.31	75.16
			Ant 1	23.32				
		64QAM	Ant 0	23.28	26.29	12	38.29	
			Ant 1	23.27				
Highest	20	QPSK	Ant 0	23.40	26.35	12	38.35	75.16
			Ant 1	23.27				
		64QAM	Ant 0	23.43	26.40	12	38.40	
			Ant 1	23.35				

**Remark:**

1.  $Limit=62.15dBm+10\log(bandwidth/1MHz)$ .

2.  $Directional\ gain = G_{ANT} + 10\log(N_{ANT})\ dBi = 9 + 10\log(2)\ dBi = 12dBi$ .

For FCC test plot as follows:

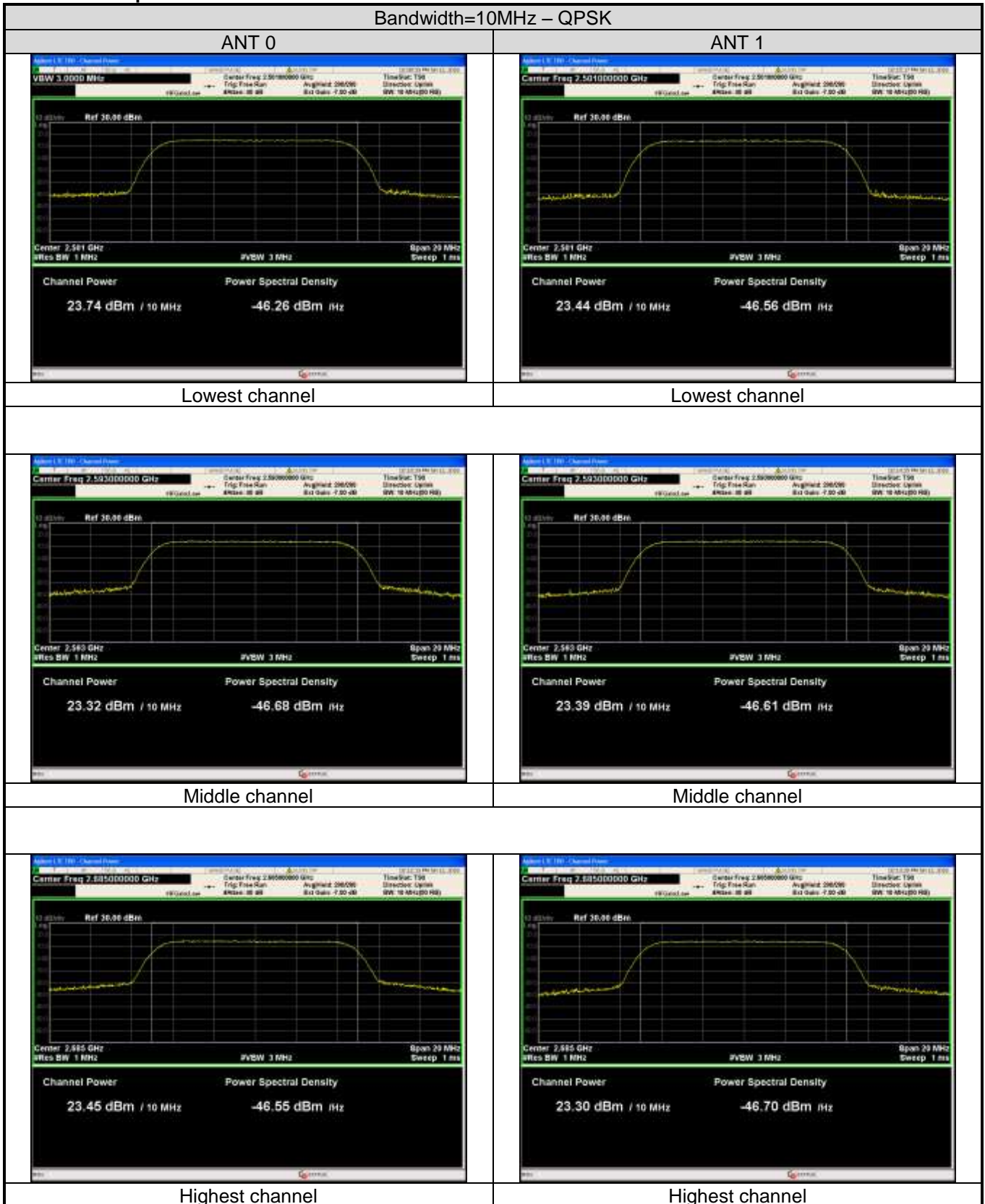

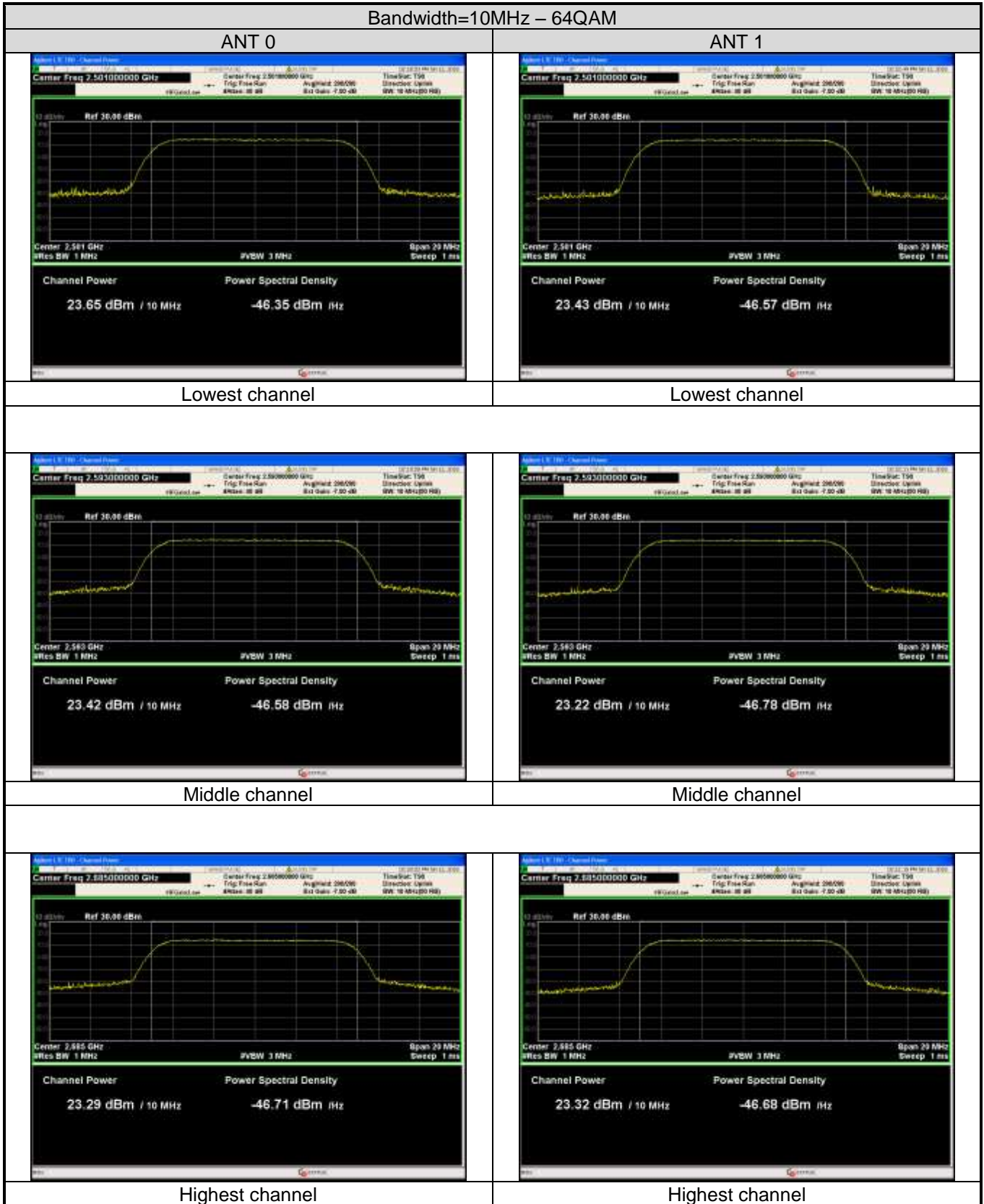

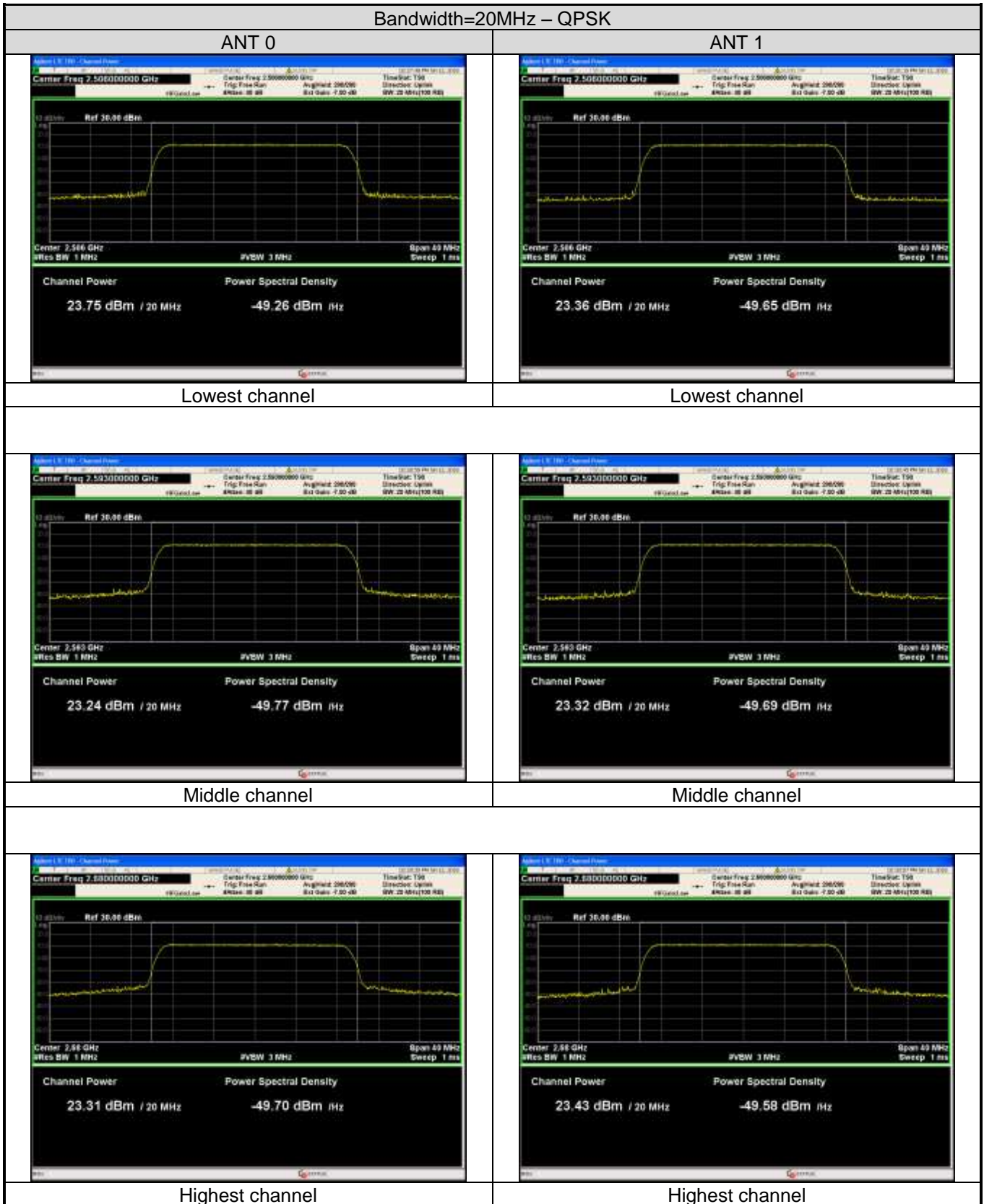

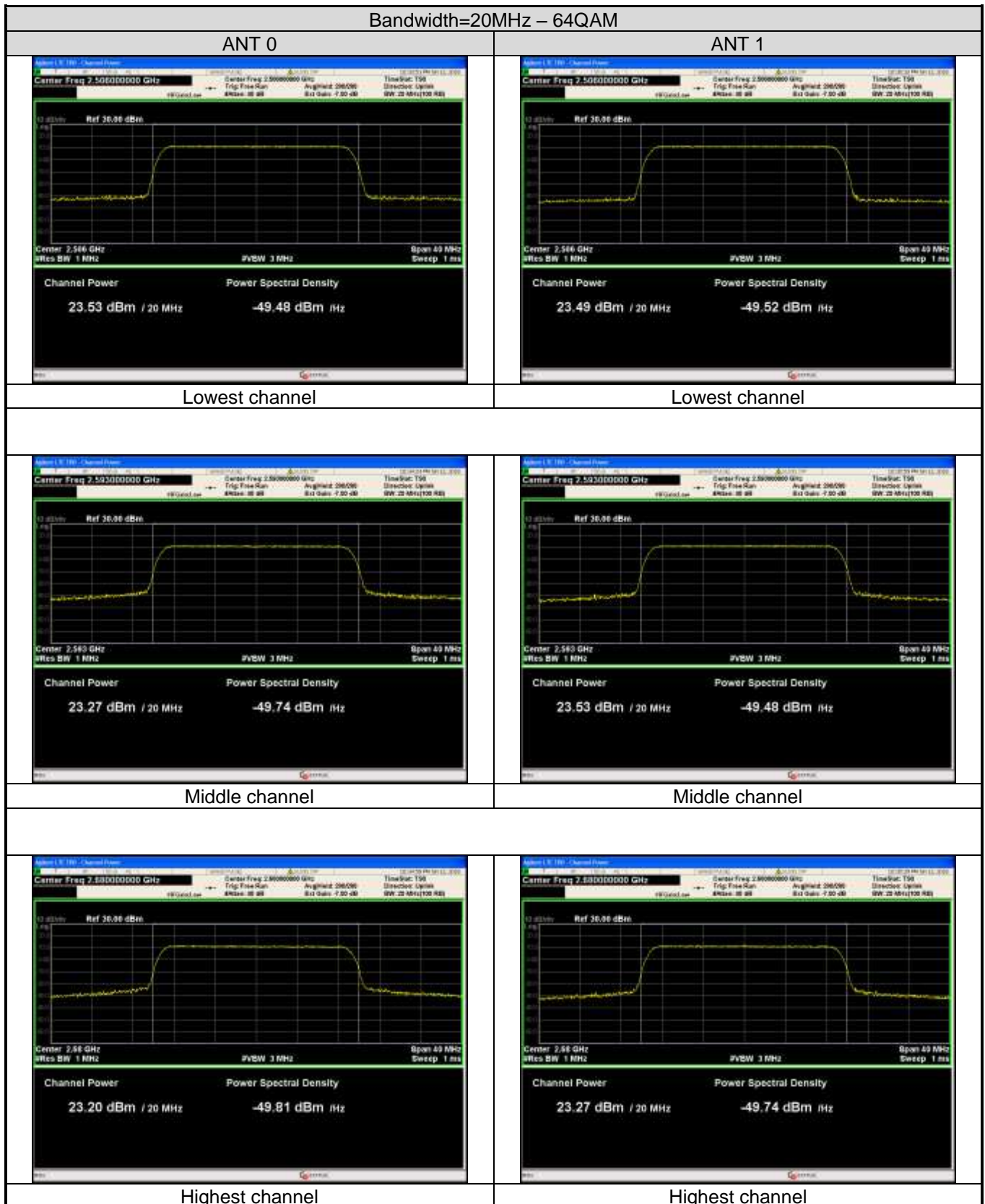

For IC test plot as follows:

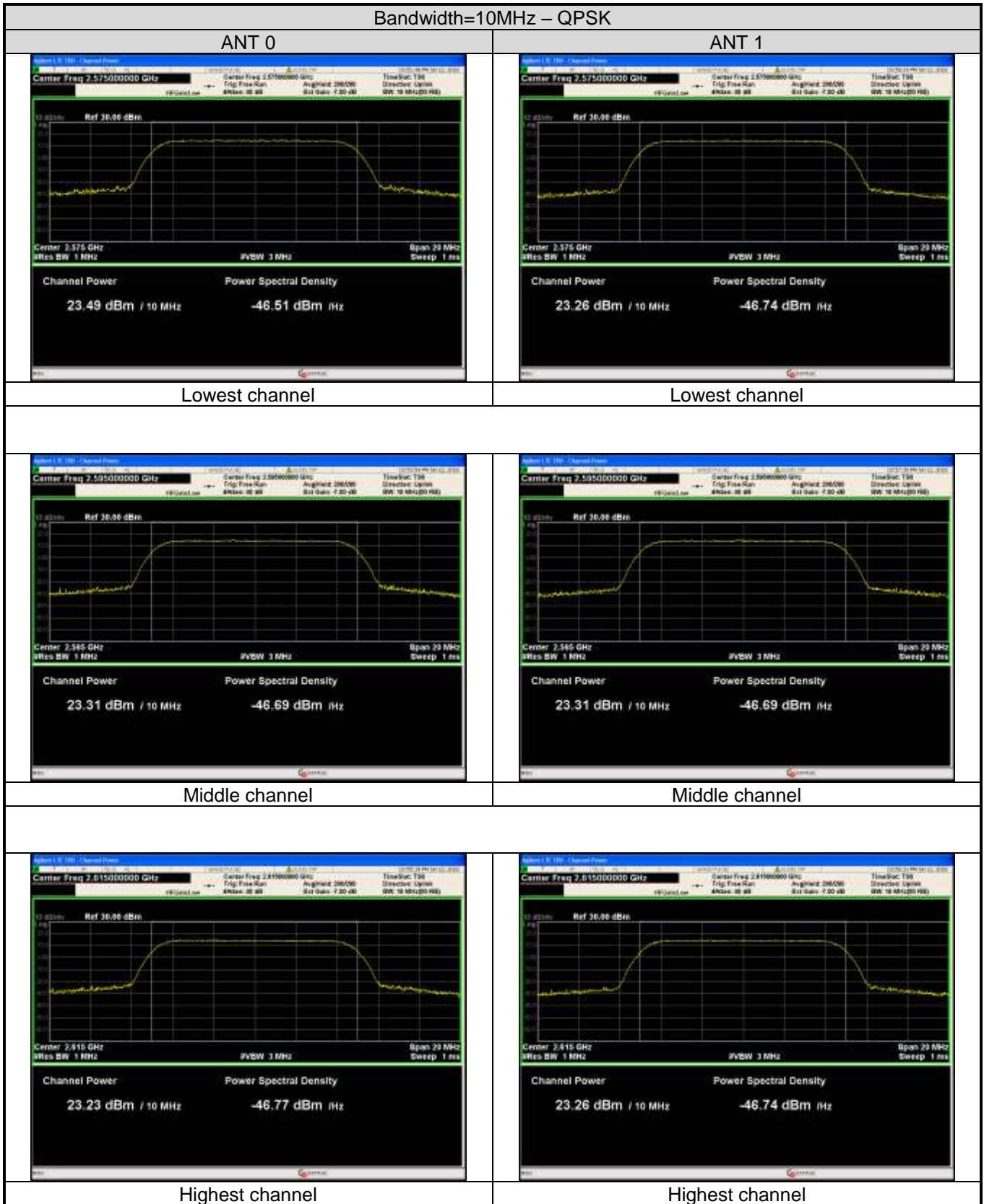

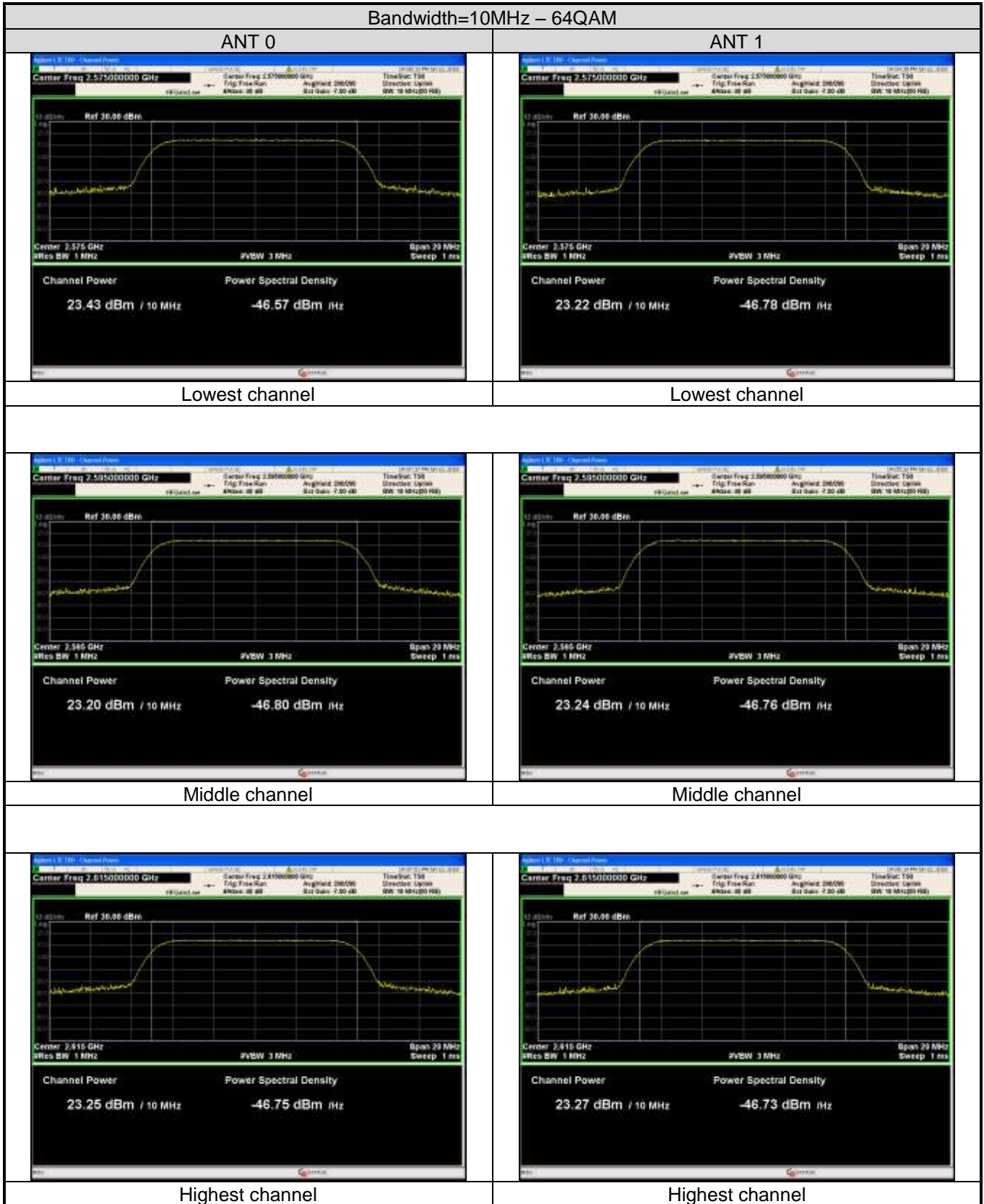



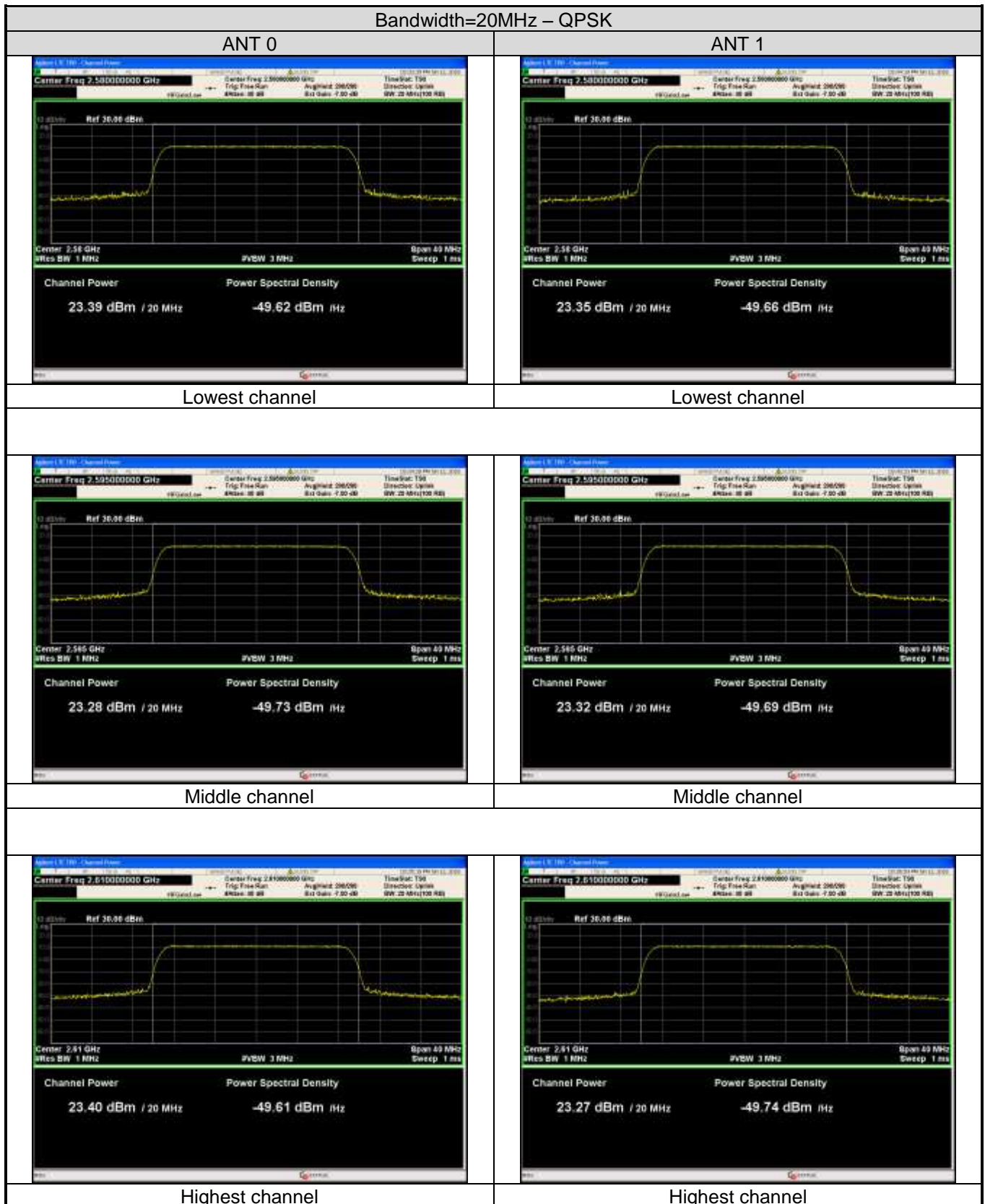

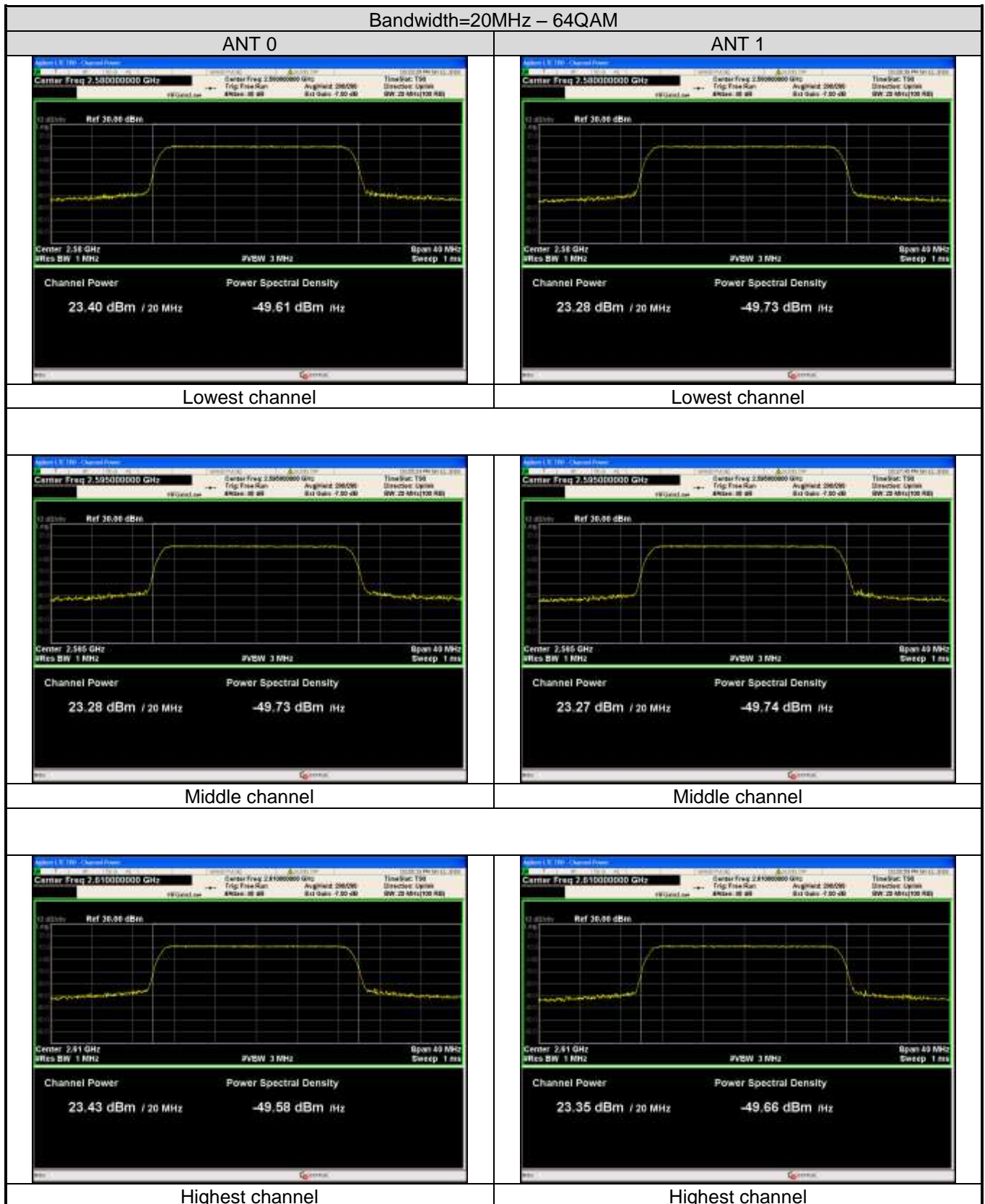

## 6.2 Peak-to-Average Ratio

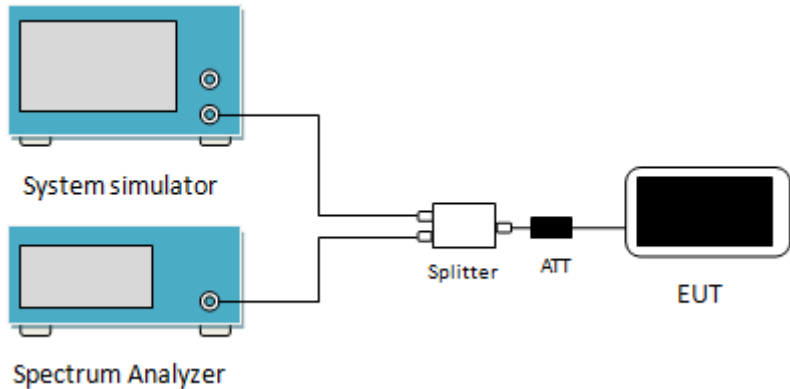
Test Requirement:	RSS-199 Section 4.4
Test Method:	ANSI/TIA-603-D 2010
Limit:	The peak-to-average ratio (PAR) of the transmission may not exceed 13 dB.
Test Setup:	 <p>The diagram shows a test setup where a System simulator and a Spectrum Analyzer are connected to a Splitter. The Splitter is connected to an ATT (Attenuator) and an EUT (Equipment Under Test).</p>
Test Procedure:	<ol style="list-style-type: none"> <li>1 The RF output of the transceiver was connected to a spectrum analyzer through appropriate attenuation.</li> <li>2 Set the CCDF option in spectrum analyzer, <math>RBW \geq OBW</math>,</li> <li>3 Set the EUT working in highest power level, measured and recorded the 0.1% as PAPR level.</li> <li>4 Repeat step 1~3 at other frequency and modulations.</li> </ol>
Test Instruments:	Refer to section 5.9 for details
Test mode:	Refer to section 5.3 for details
Test results:	Passed

### For FCC measurement data:

Bandwidth	Modulation	PAPR	
		ANT 0	ANT 1
10MHz	QPSK	9.35	9.25
	64QAM	9.26	9.35
20MHz	QPSK	9.48	9.38
	64QAM	9.37	9.77

### For IC measurement data:

Bandwidth	Modulation	PAPR	
		ANT 0	ANT 1
10MHz	QPSK	9.27	9.41
	64QAM	9.31	9.45
20MHz	QPSK	9.68	8.61
	64QAM	9.18	9.53

For FCC test plots as below:

Bandwidth=10MHz for Middle channel – QPSK

ANT 0

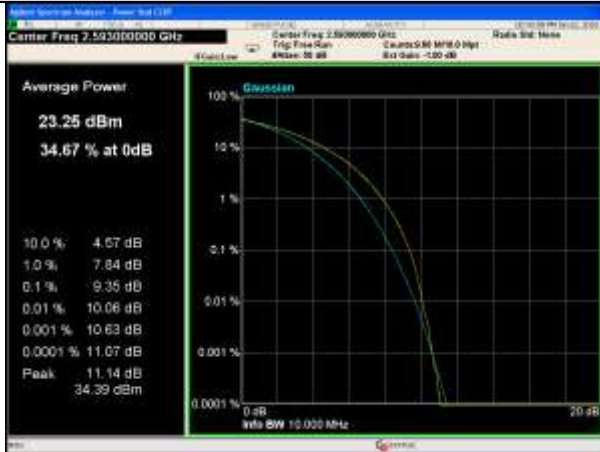

ANT 1

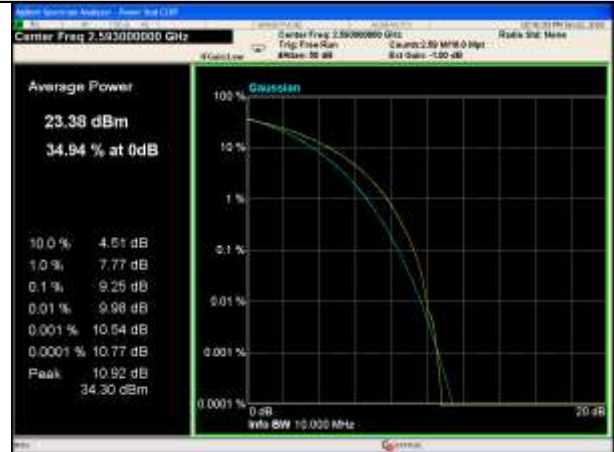

Bandwidth=10MHz for Middle channel – 64QAM

ANT 0

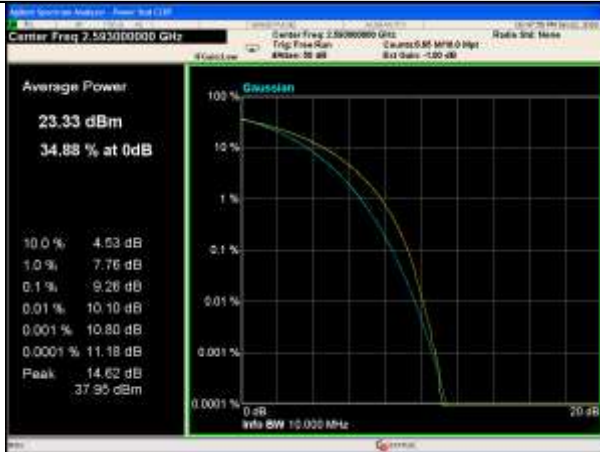

ANT 1



Bandwidth=20MHz for Middle channel – QPSK

ANT 0

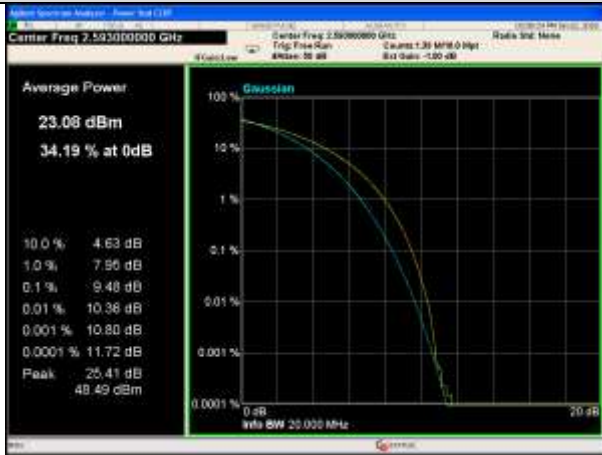

ANT 1

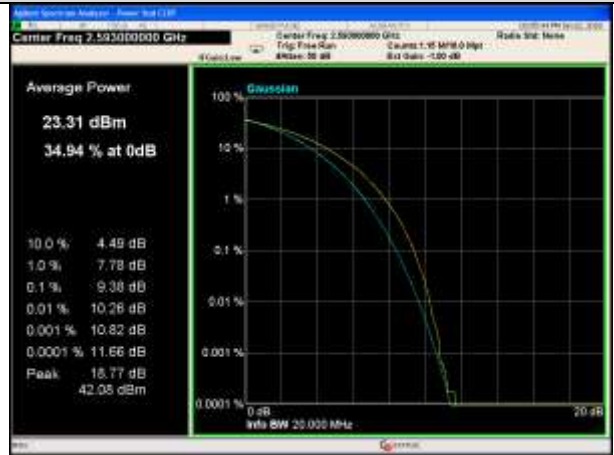

Bandwidth=20MHz for Middle channel – 64QAM

ANT 0

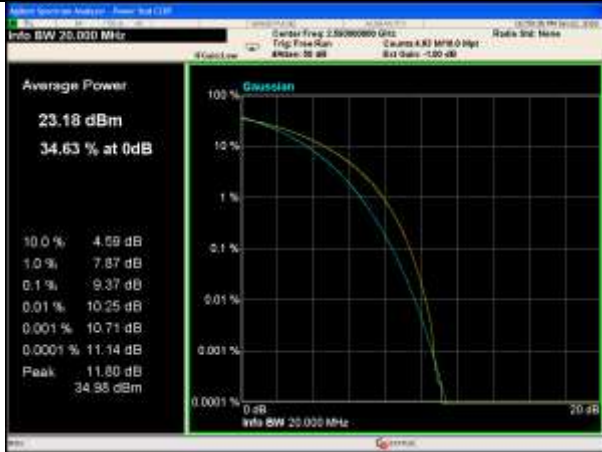

ANT 1

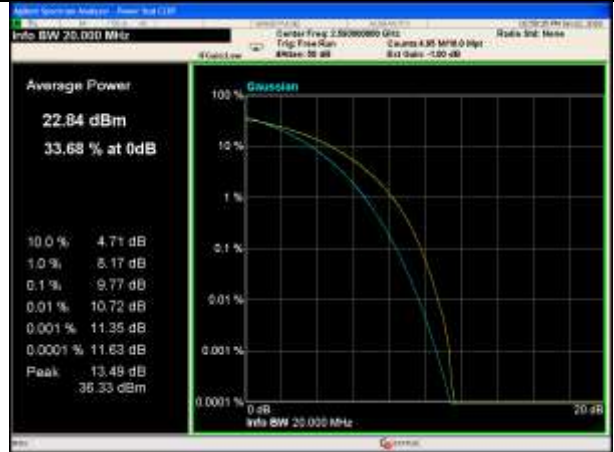

For IC test plots as below:

Bandwidth=10MHz for Middle channel – QPSK

ANT 0



ANT 1

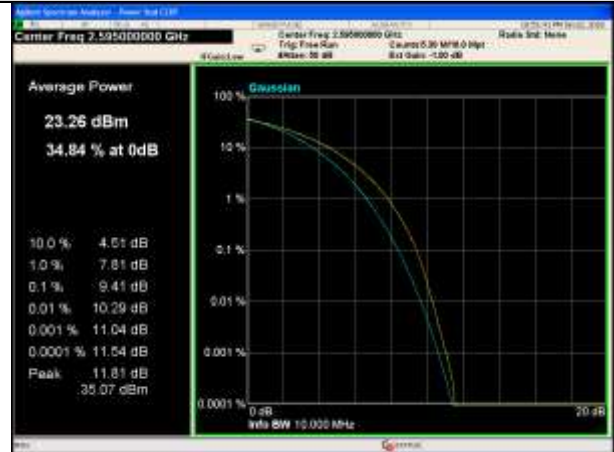

Bandwidth=10MHz for Middle channel – 64QAM

ANT 0



ANT 1

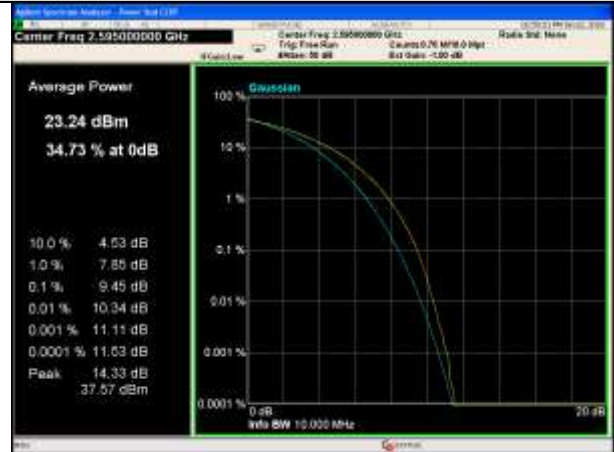

Bandwidth=20MHz for Middle channel – QPSK

ANT 0

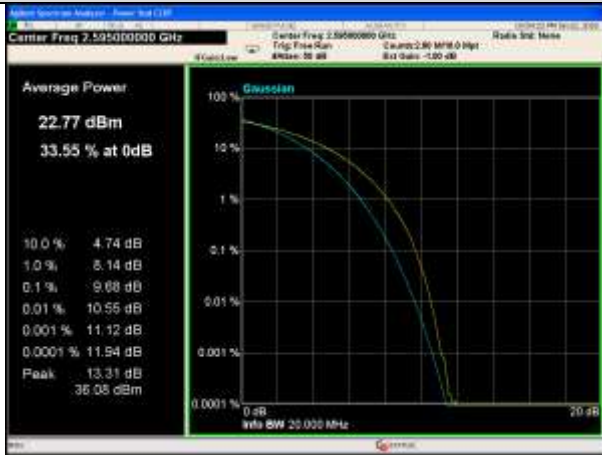

ANT 1



Bandwidth=20MHz for Middle channel – 64QAM

ANT 0

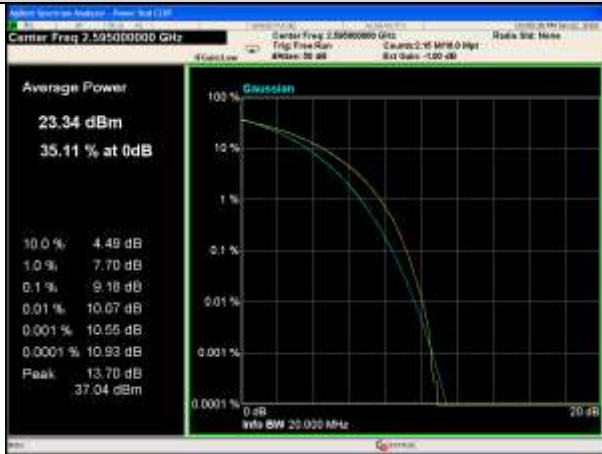

ANT 1

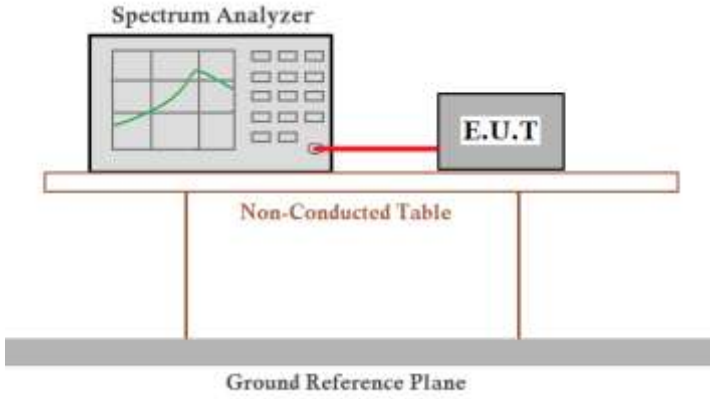

## 6.3 Occupy Bandwidth

Test Requirement:	Part 27.53(m)(6) and RSS-Gen Section 6.6
Test Method:	ANSI/TIA-603-D 2010, FCC part 2.1049 and RSS-199 Section 4.2
Test setup:	 <p>The diagram illustrates the test setup. A Spectrum Analyzer is connected to an E.U.T. (Equipment Under Test) via a red cable. Both the Spectrum Analyzer and the E.U.T. are placed on a Non-Conducted Table. The table is supported by a Ground Reference Plane.</p>
Test Procedure:	<ol style="list-style-type: none"> <li>1. The EUT's output RF connector was connected with a short cable to the spectrum analyzer</li> <li>2. The transmitter shall be operated at its maximum carrier power measured under normal test conditions.</li> <li>3. The span of the analyzer shall be set to capture all products of the modulation process, including the emission skirts.</li> <li>4. The resolution bandwidth (RBW) shall be in the range of 1% to 5% of the occupied bandwidth (OBW) and video bandwidth (VBW) shall be approximately 3x RBW.</li> </ol>
Test Instruments:	Refer to section 5.9 for details
Test mode:	Refer to section 5.3 for details
Test results:	Passed



**For FCC measurement data:**

Test Channel	Bandwidth (MHz)	Modulation	Ant. Port	26dB Occupy bandwidth (MHz)	99% Occupy bandwidth (MHz)
Lowest	10	QPSK	Ant 0	9.33	8.99
			Ant 1	9.37	8.93
		64QAM	Ant 0	9.31	8.93
			Ant 1	9.37	8.93
Middle	10	QPSK	Ant 0	9.36	8.94
			Ant 1	9.39	8.93
		64QAM	Ant 0	9.39	8.94
			Ant 1	9.43	8.93
Highest	10	QPSK	Ant 0	9.41	8.93
			Ant 1	9.36	8.94
		64QAM	Ant 0	9.33	8.95
			Ant 1	9.39	8.94
Lowest	20	QPSK	Ant 0	18.62	17.86
			Ant 1	18.69	17.85
		64QAM	Ant 0	18.62	17.85
			Ant 1	18.54	17.84
Middle	20	QPSK	Ant 0	18.61	17.86
			Ant 1	18.55	17.86
		64QAM	Ant 0	18.61	17.86
			Ant 1	18.56	17.87
Highest	20	QPSK	Ant 0	18.72	17.96
			Ant 1	18.85	17.87
		64QAM	Ant 0	18.62	17.86
			Ant 1	18.57	17.86

**For IC measurement data:**

Test Channel	Bandwidth (MHz)	Modulation	Ant. Port	26dB Occupy bandwidth (MHz)	99% Occupy bandwidth (MHz)
Lowest	10	QPSK	Ant 0	9.33	8.94
			Ant 1	9.37	8.94
		64QAM	Ant 0	9.33	8.94
			Ant 1	9.49	8.94
Middle	10	QPSK	Ant 0	9.36	8.94
			Ant 1	9.34	8.93
		64QAM	Ant 0	9.38	8.93
			Ant 1	9.43	8.94
Highest	10	QPSK	Ant 0	9.39	8.93
			Ant 1	9.42	8.93
		64QAM	Ant 0	9.37	8.95
			Ant 1	9.33	8.94
Lowest	20	QPSK	Ant 0	18.67	17.87
			Ant 1	18.61	17.85
		64QAM	Ant 0	18.52	17.85
			Ant 1	18.66	17.86
Middle	20	QPSK	Ant 0	18.56	17.86
			Ant 1	18.56	17.84
		64QAM	Ant 0	18.61	17.87
			Ant 1	18.60	17.84
Highest	20	QPSK	Ant 0	18.74	17.86
			Ant 1	18.97	17.87
		64QAM	Ant 0	18.55	17.87
			Ant 1	18.56	17.86

For FCC test plot as follows:

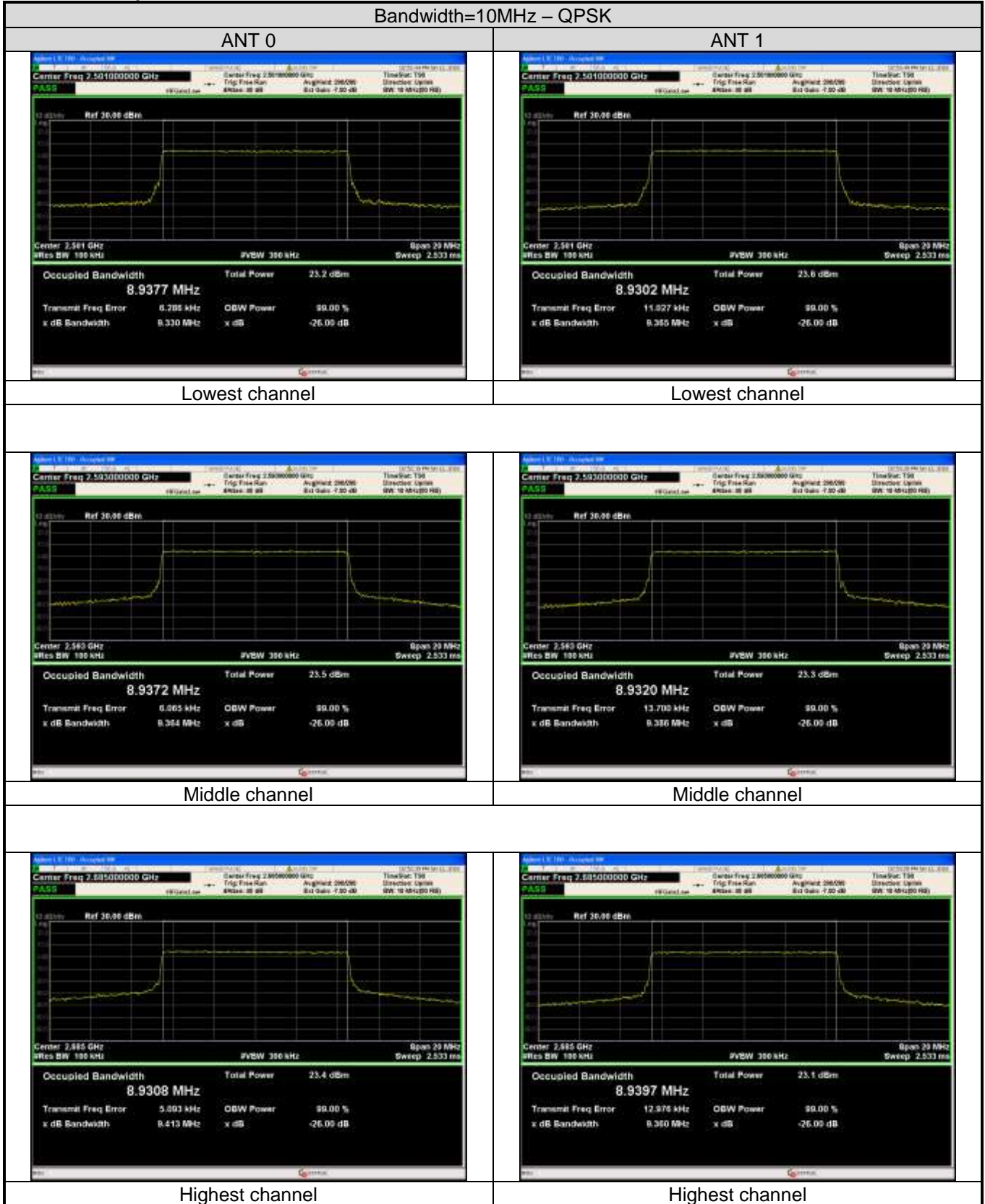

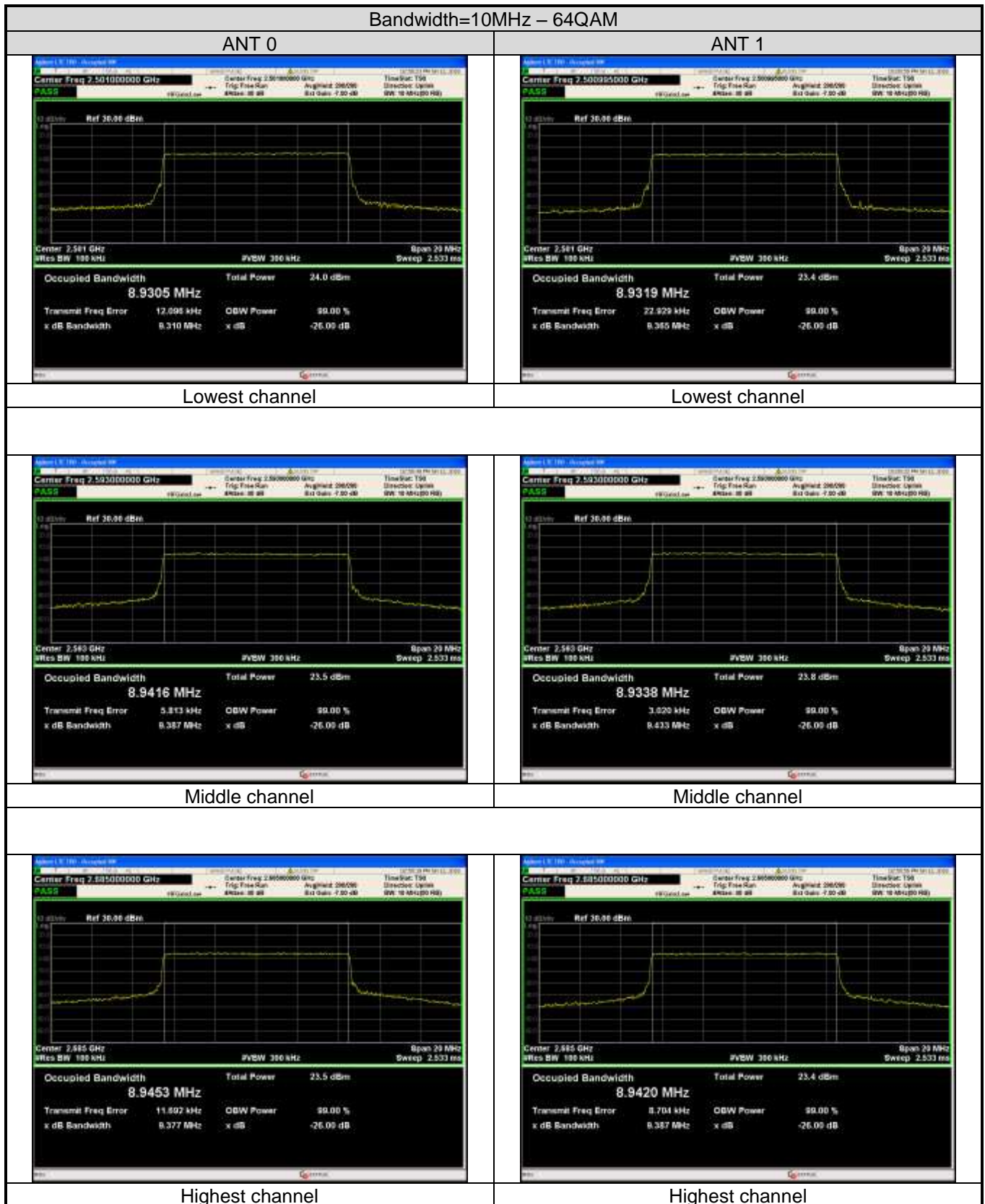

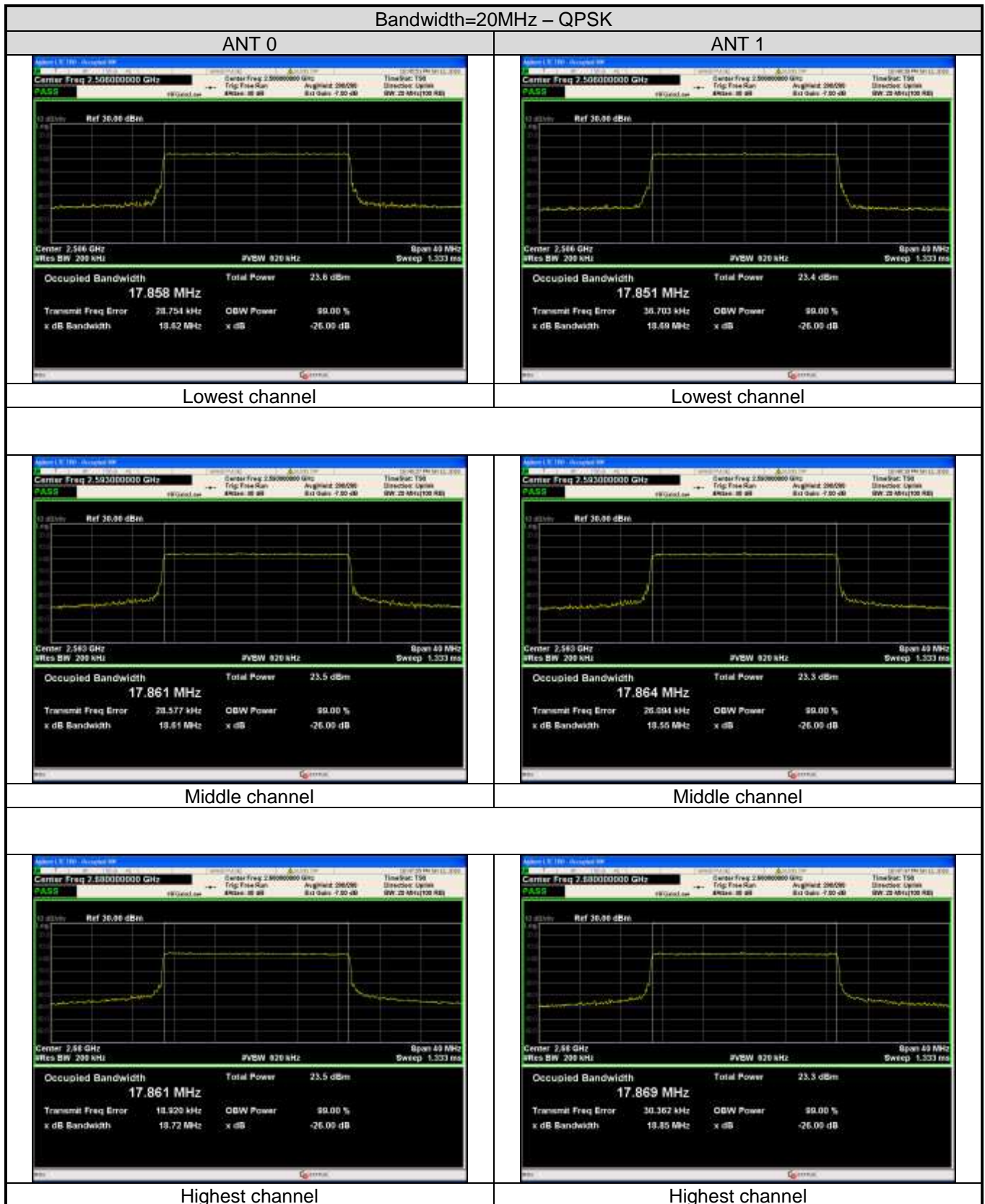

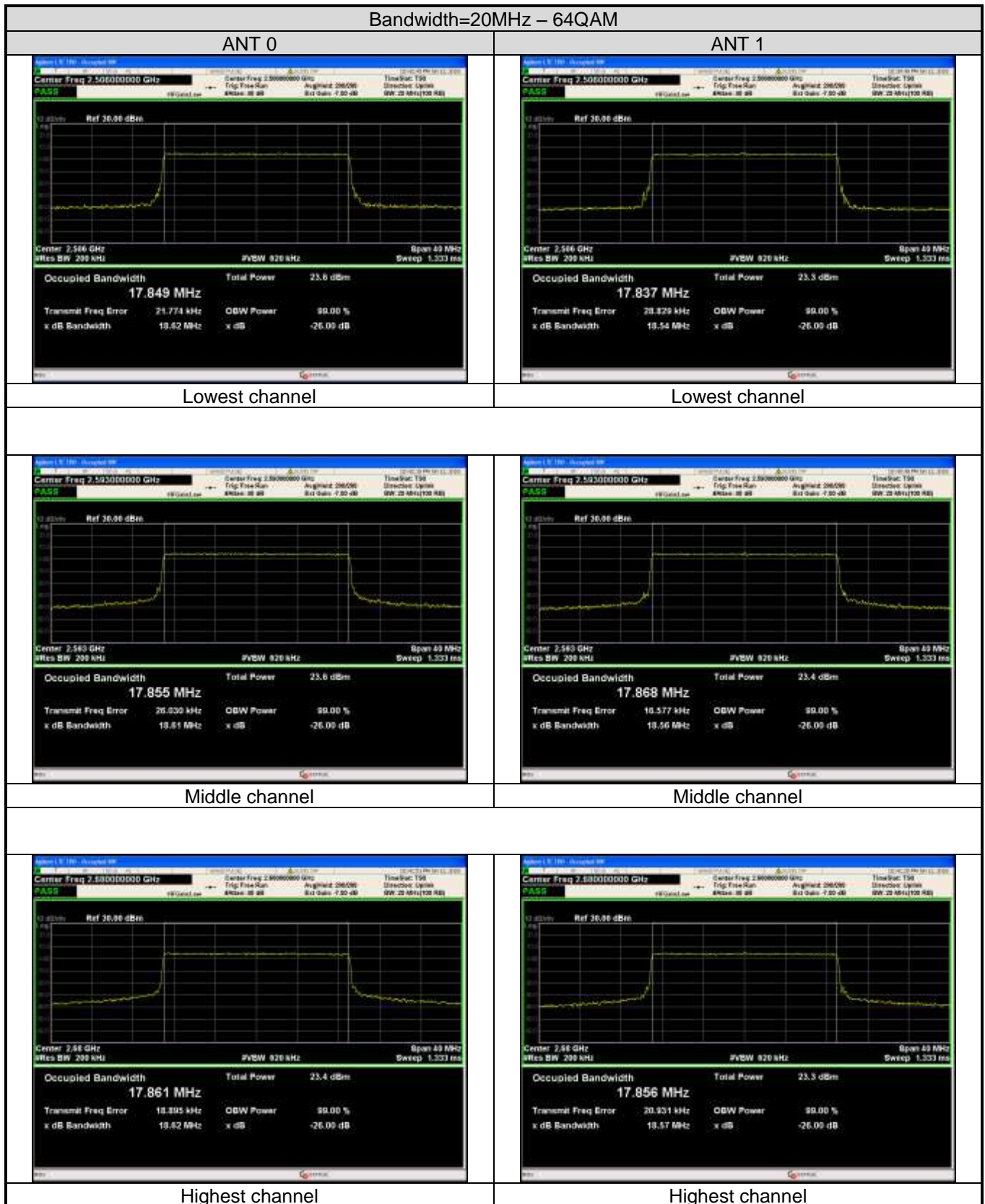

For FCC test plot as follows:

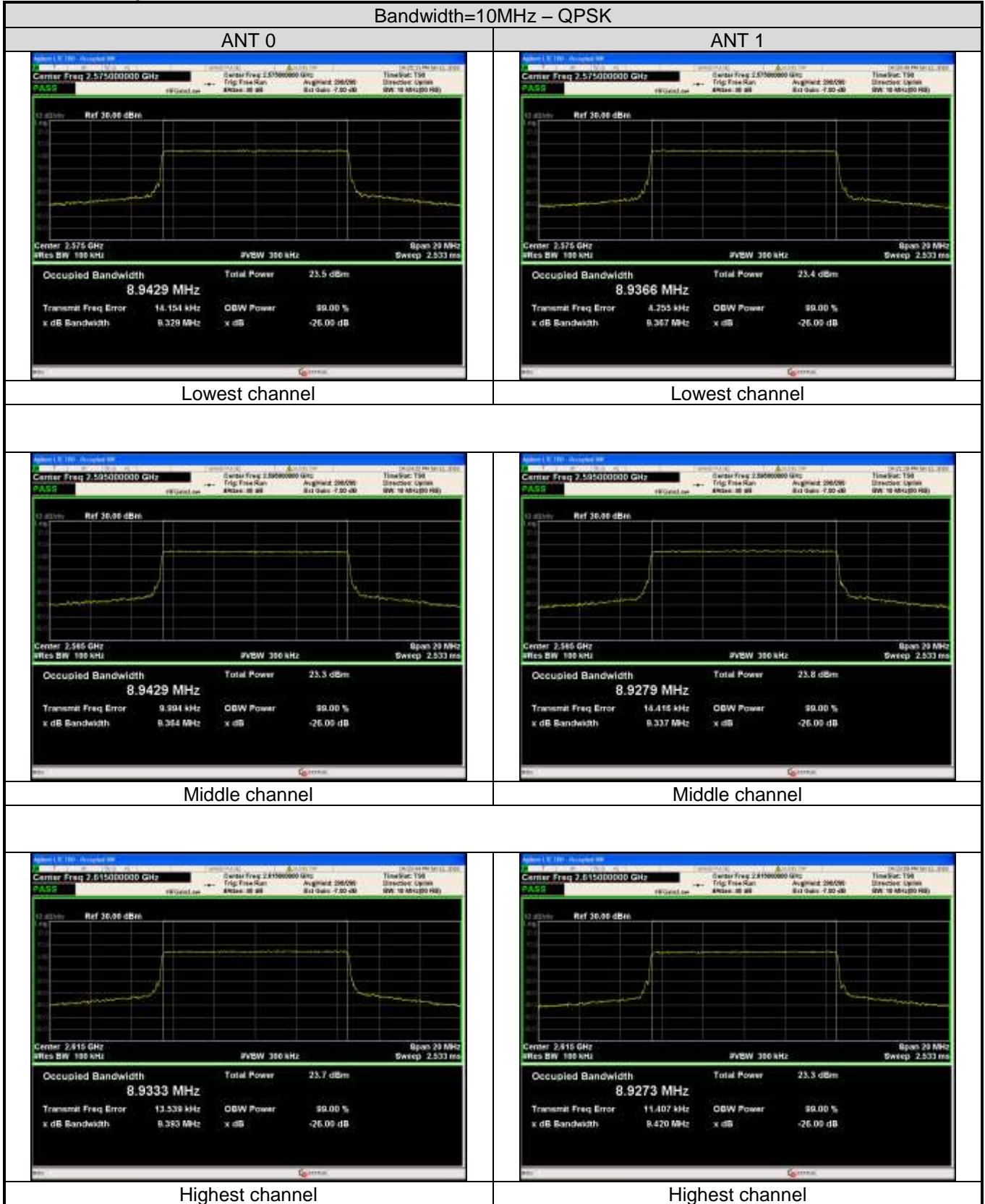

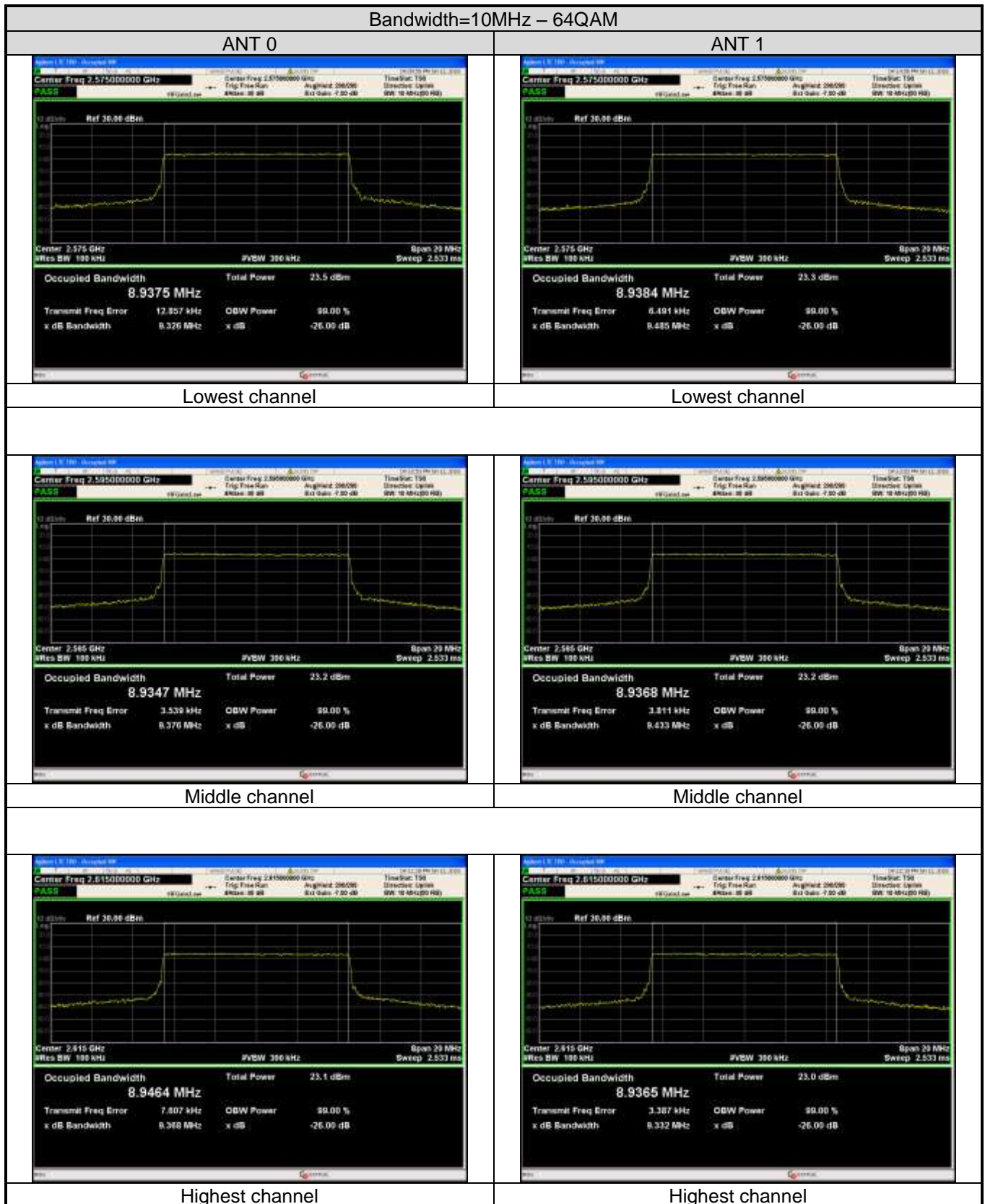



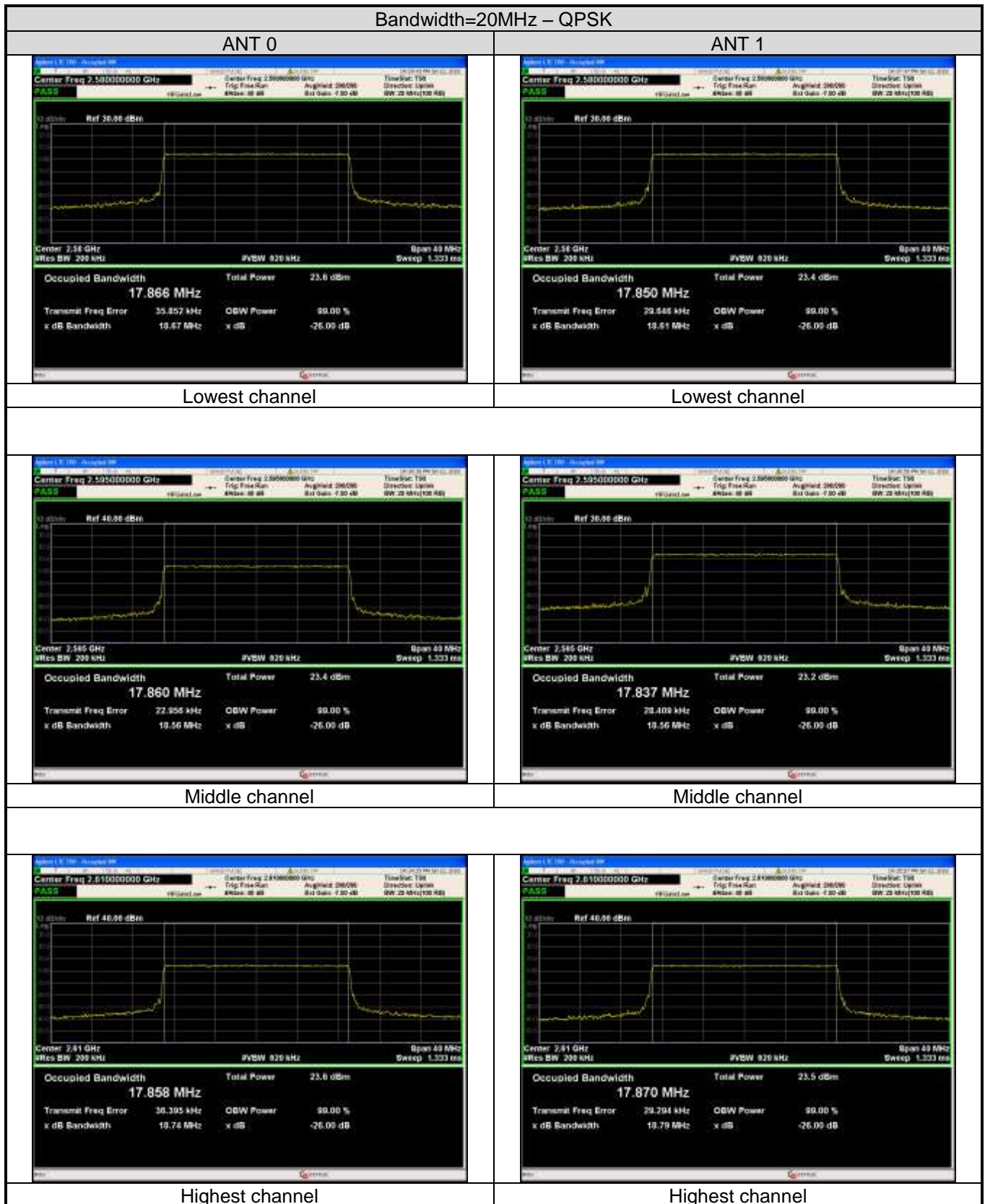

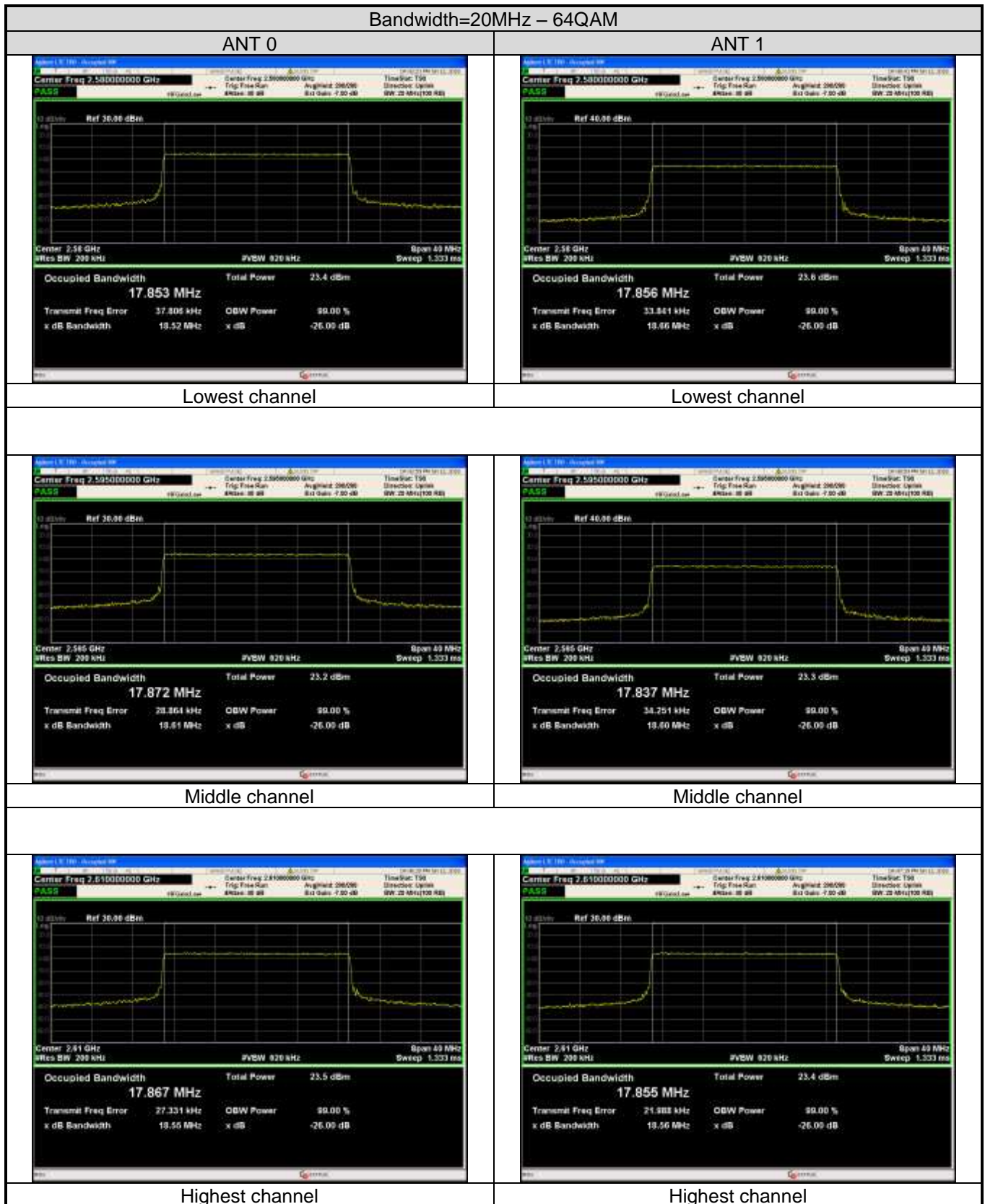

## 6.4 Out of band emission at antenna terminals

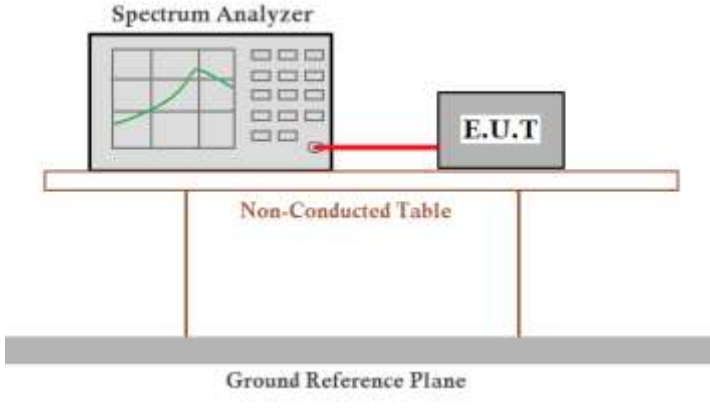
Test Requirement:	Part 27.53(m)(2) and RSS-199 Section 4.5(a)
Test Method:	ANSI/TIA-603-D 2010, FCC part 2.1051 and RSS-Gen Section 6.13
Limit:	-13dBm
Test setup:	 <p>The diagram illustrates the test setup. A Spectrum Analyzer is connected to an E.U.T. (Equipment Under Test) via a red cable. Both the Spectrum Analyzer and the E.U.T. are placed on a Non-Conducted Table. The table is supported by two vertical legs and sits on a Ground Reference Plane.</p>
Test Procedure:	<ol style="list-style-type: none"> <li>1 The RF output of the transceiver was connected to a spectrum analyzer through appropriate attenuation.</li> <li>2 The resolution bandwidth of the spectrum analyzer was set at 100 kHz when below 1GHz, 1MHz when above 1 GHz; sufficient scans were taken to show the out of band Emissions if any up to 10th harmonic.</li> <li>3 For the out of band: Set the RBW=100 kHz, VBW=300 kHz when below 1 GHz, RBW =1 MHz, VBW=3 MHz when above 1 GHz, Start=30MHz, Stop= 10th harmonic.</li> <li>4 Band Edge Requirements: In the 1 MHz bands immediately outside and adjacent to the frequency block, a resolution bandwidth of at least 1 percent of the emission bandwidth of the fundamental emission of the transmitter may be employed to measure the out of band Emissions.</li> </ol>
Test Instruments:	Refer to section 5.9 for details
Test mode:	Refer to section 5.3 for details
Test results:	Passed

**Spurious emission:  
For FCC test plot as follows:**

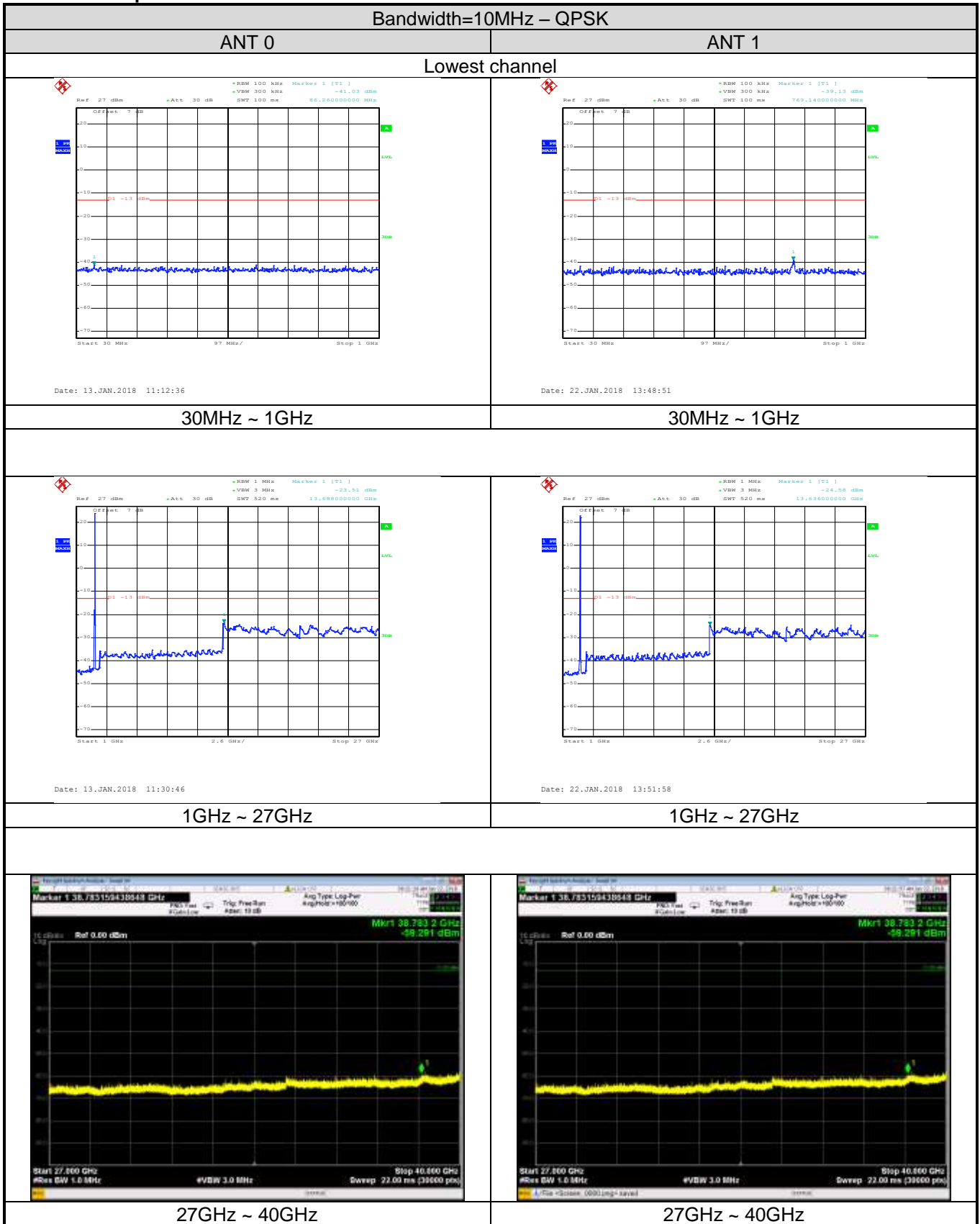

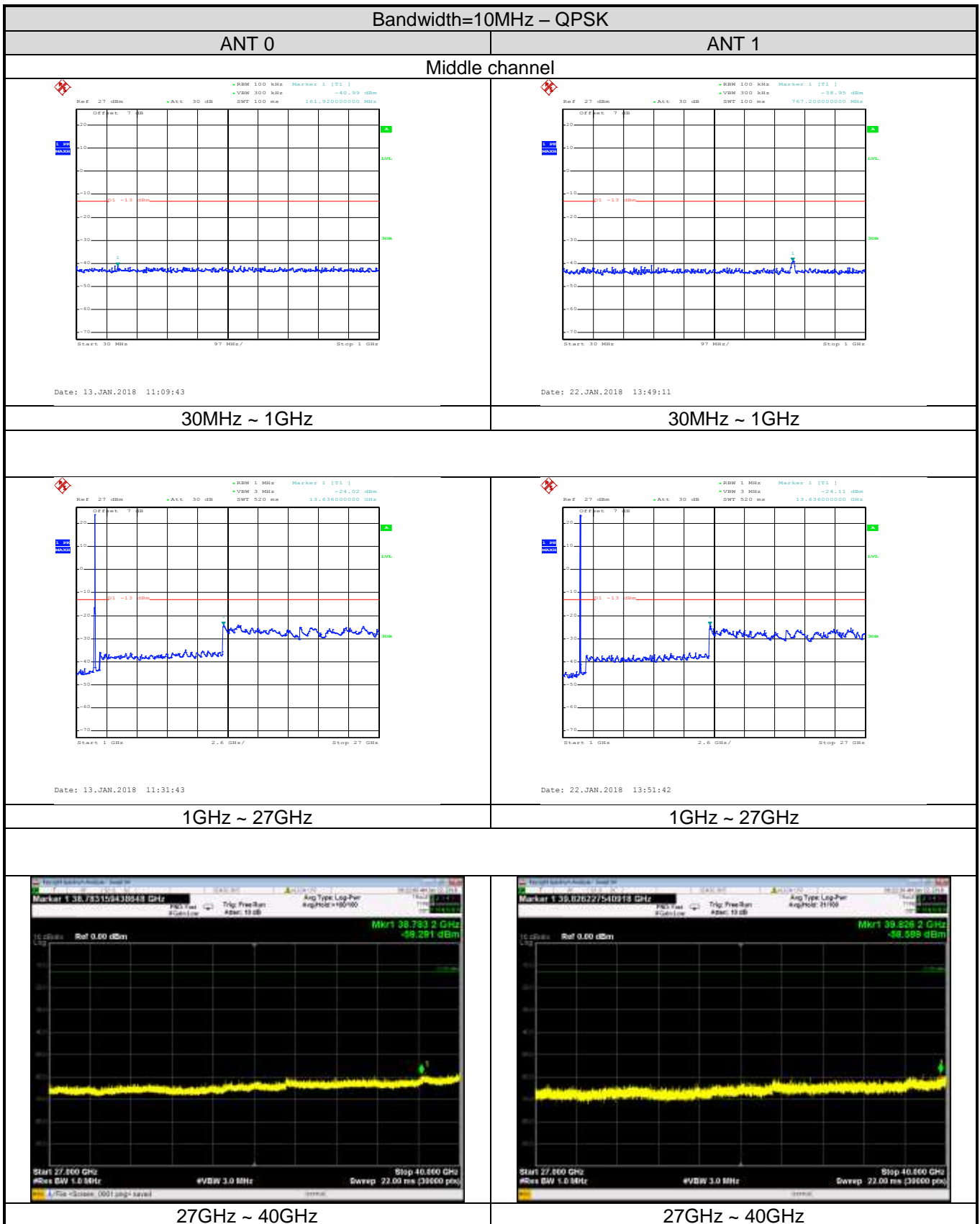

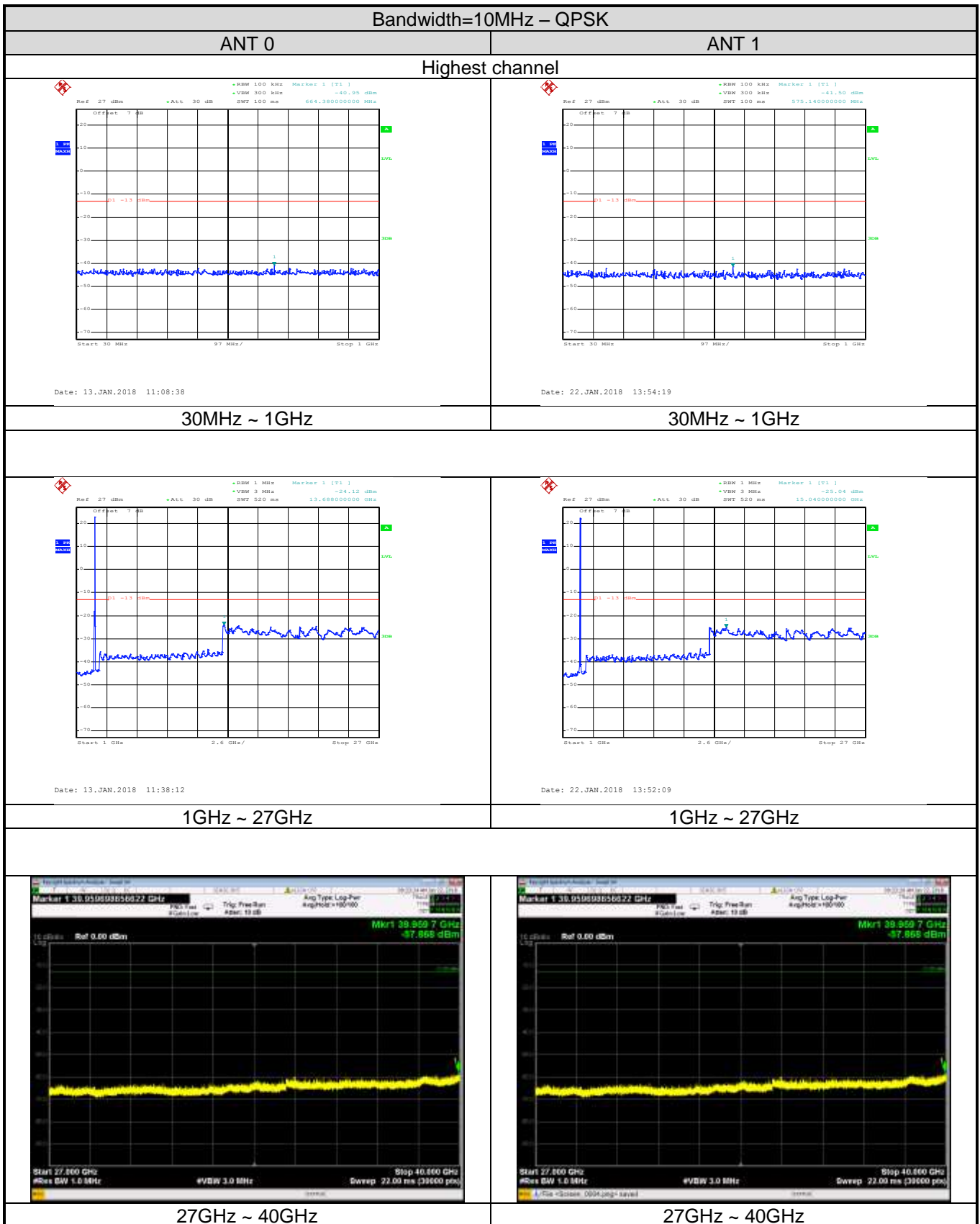

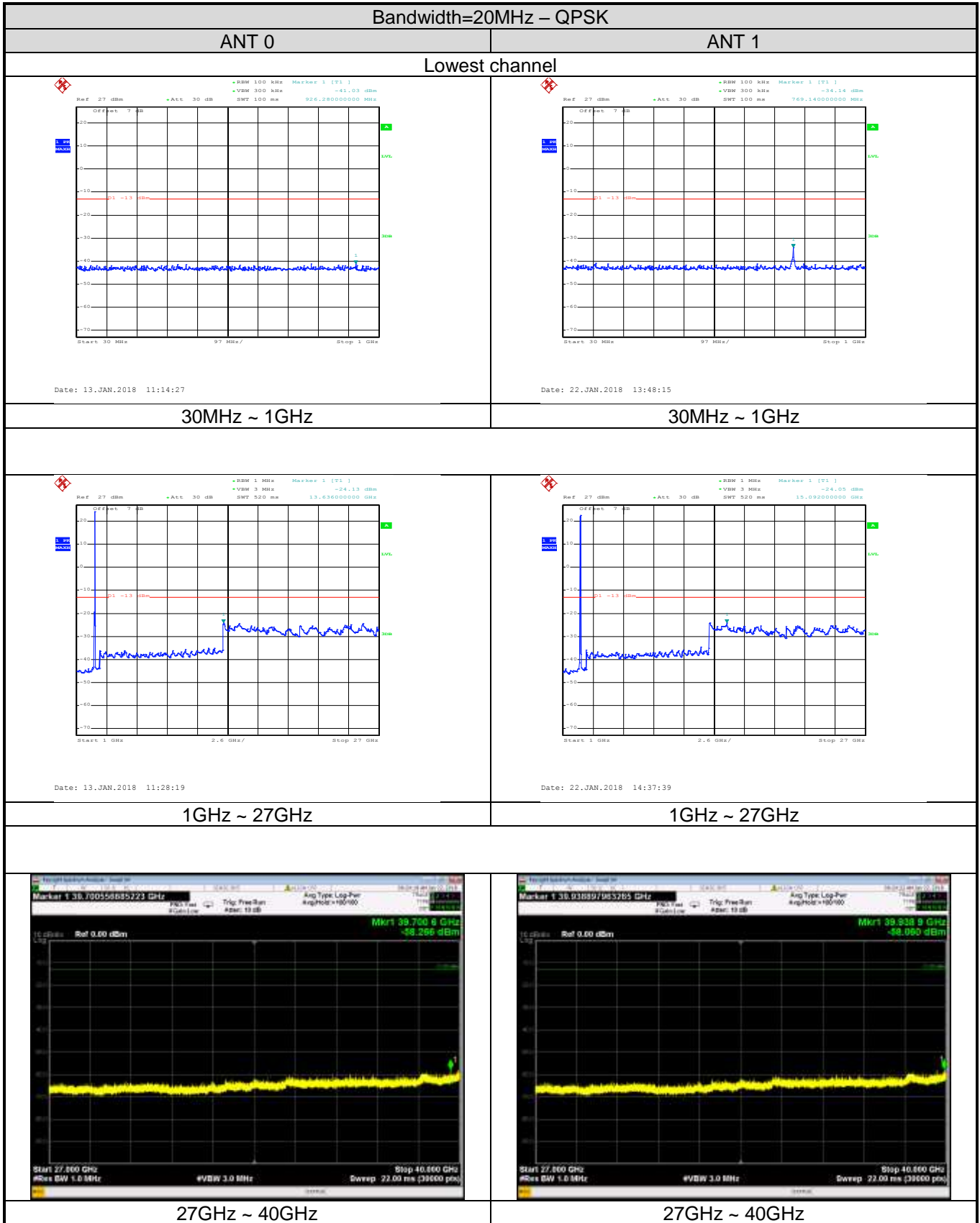

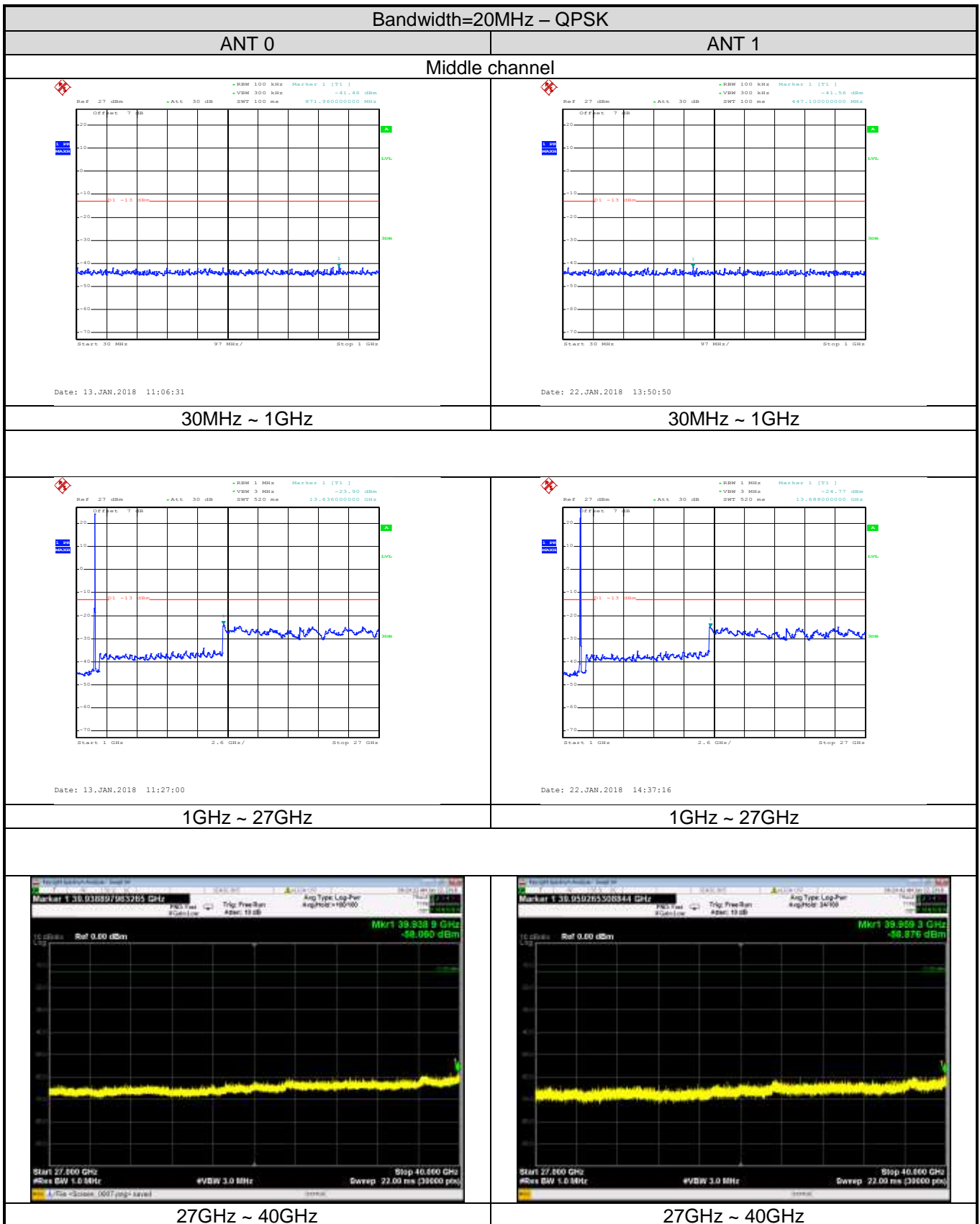



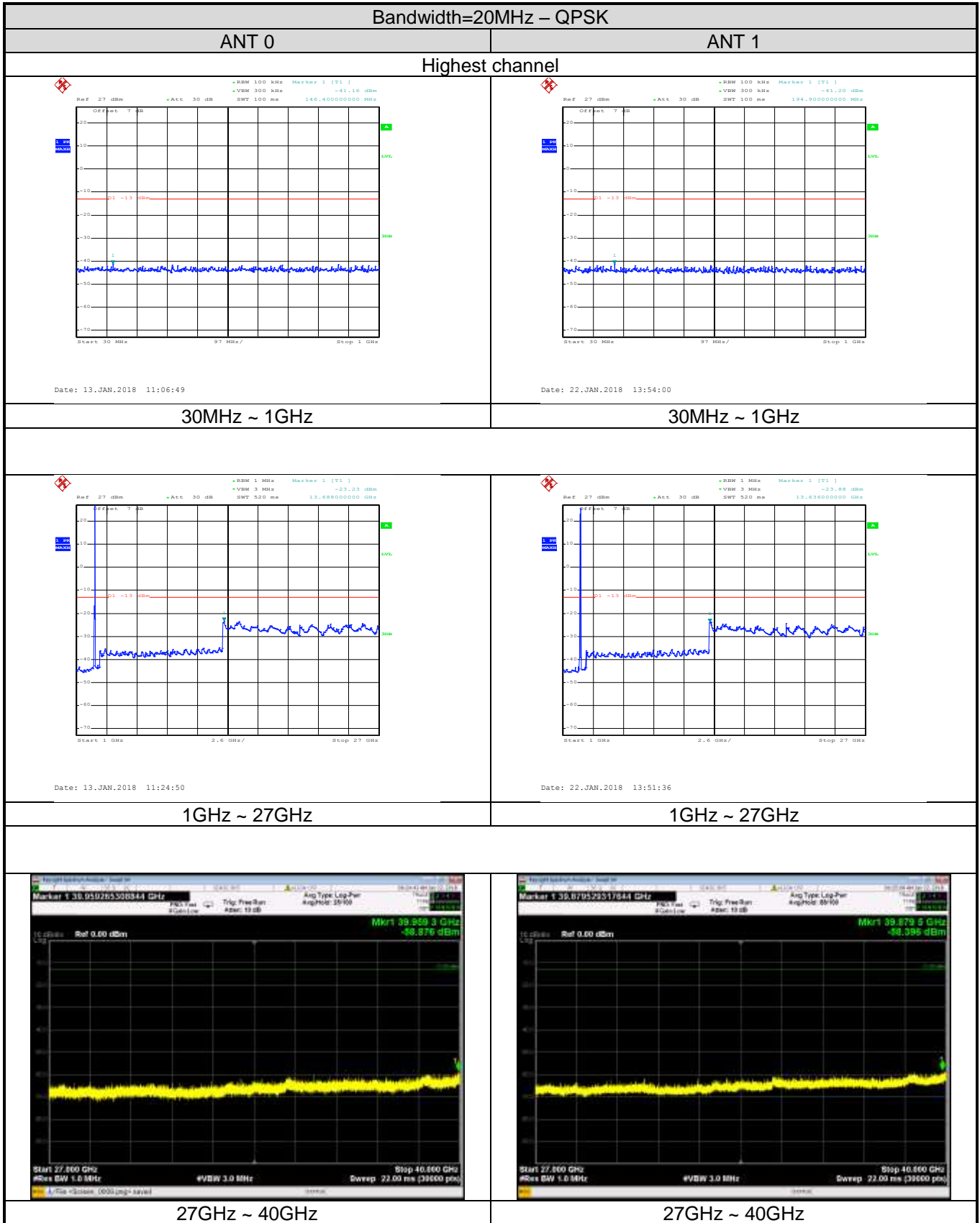

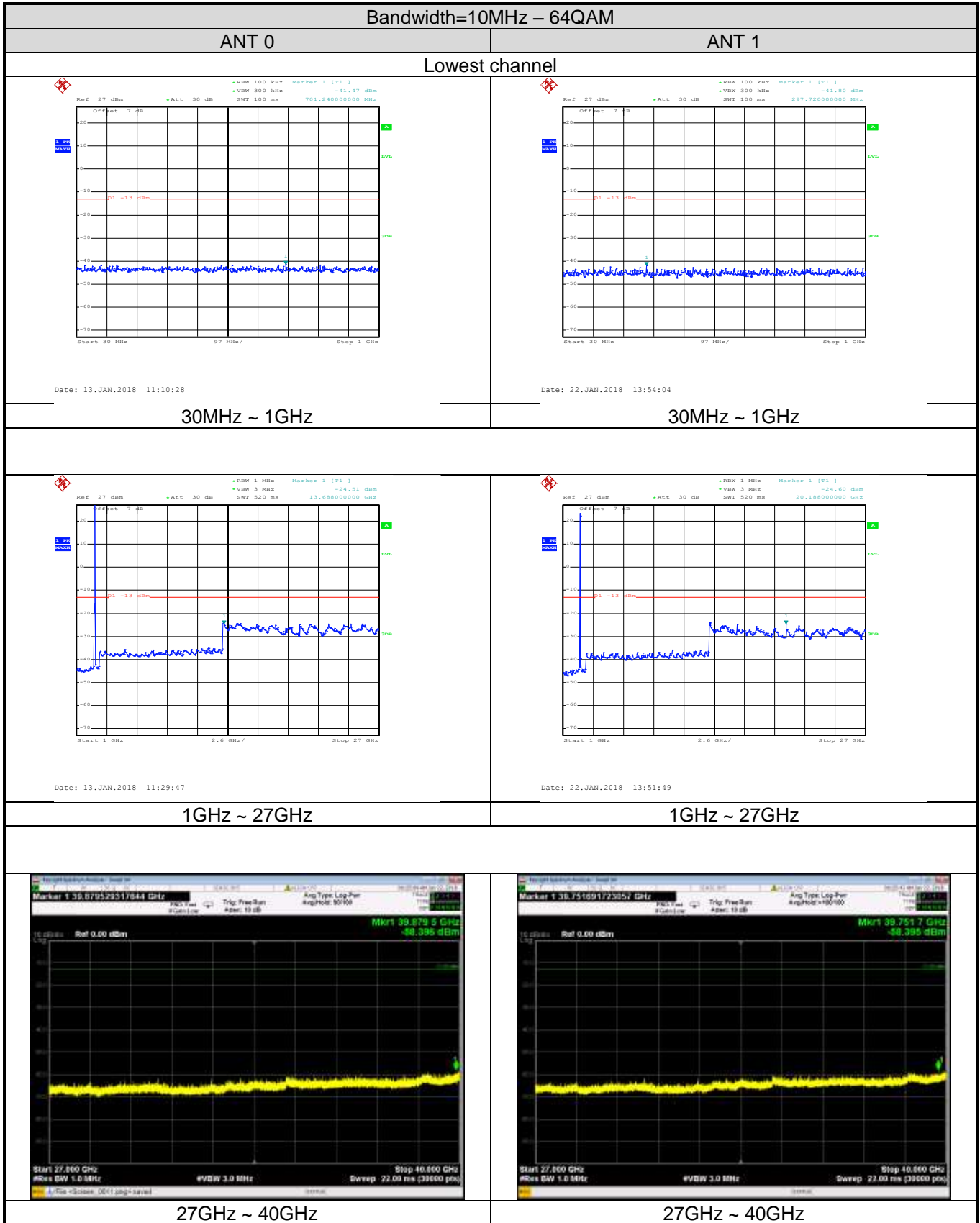

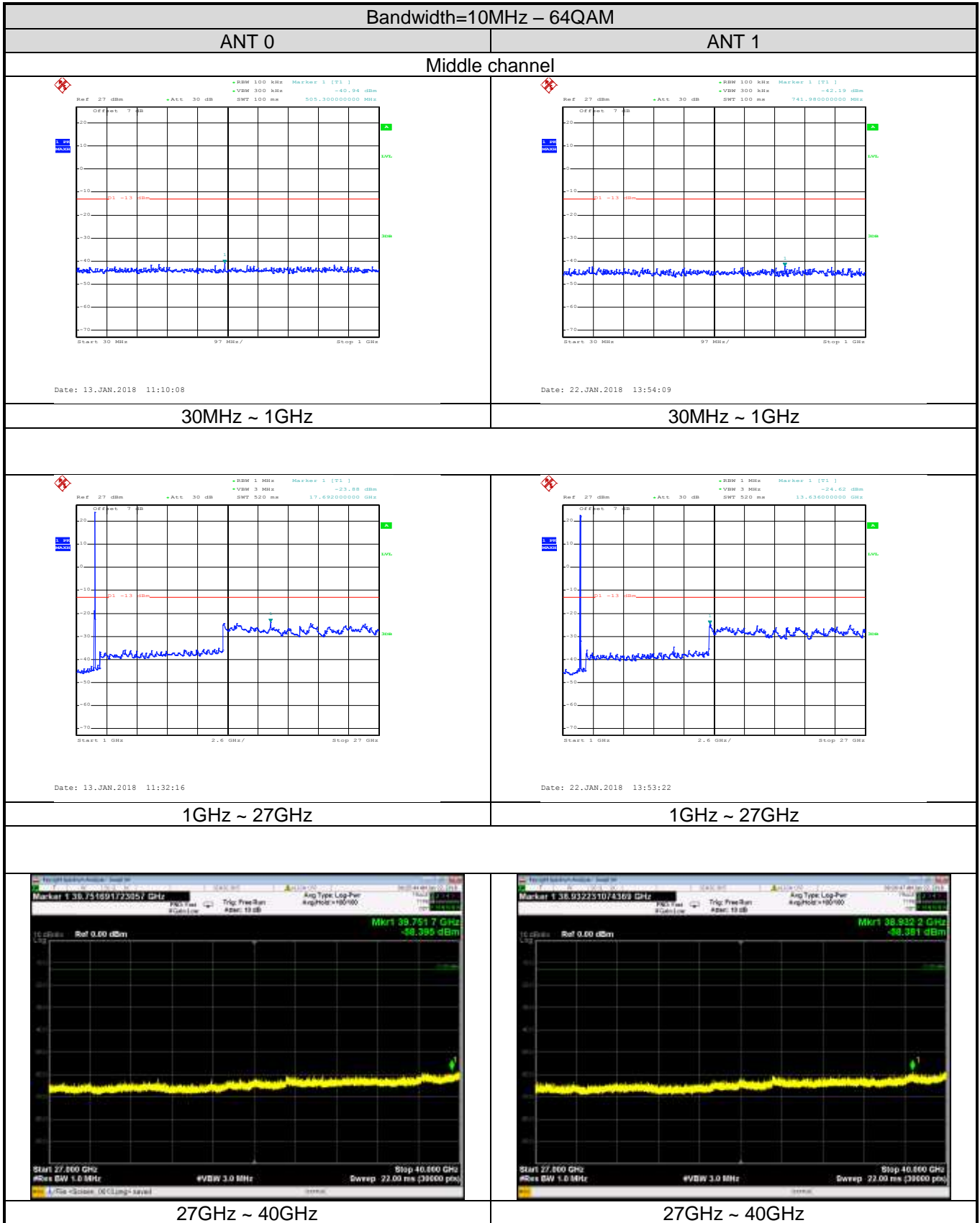

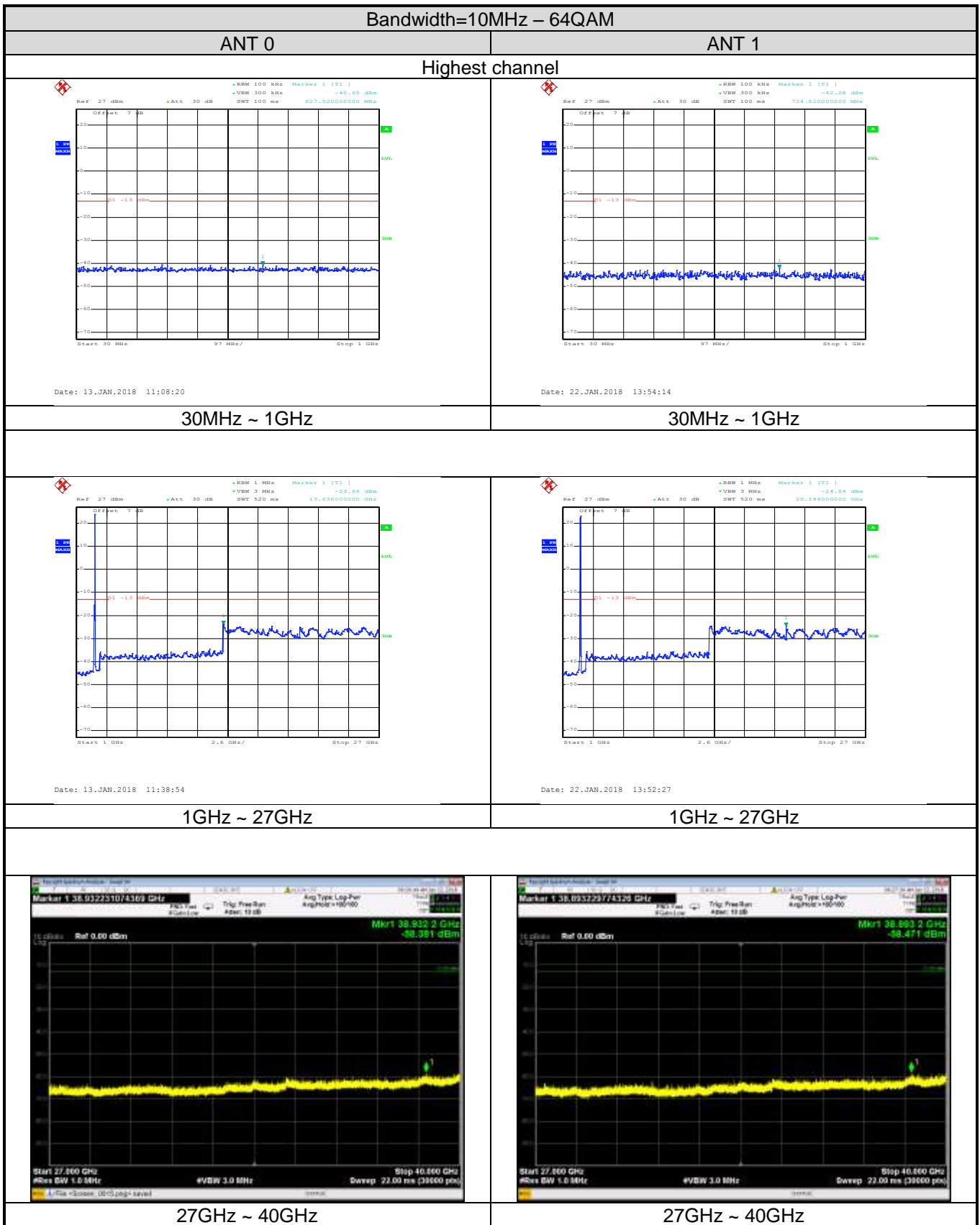

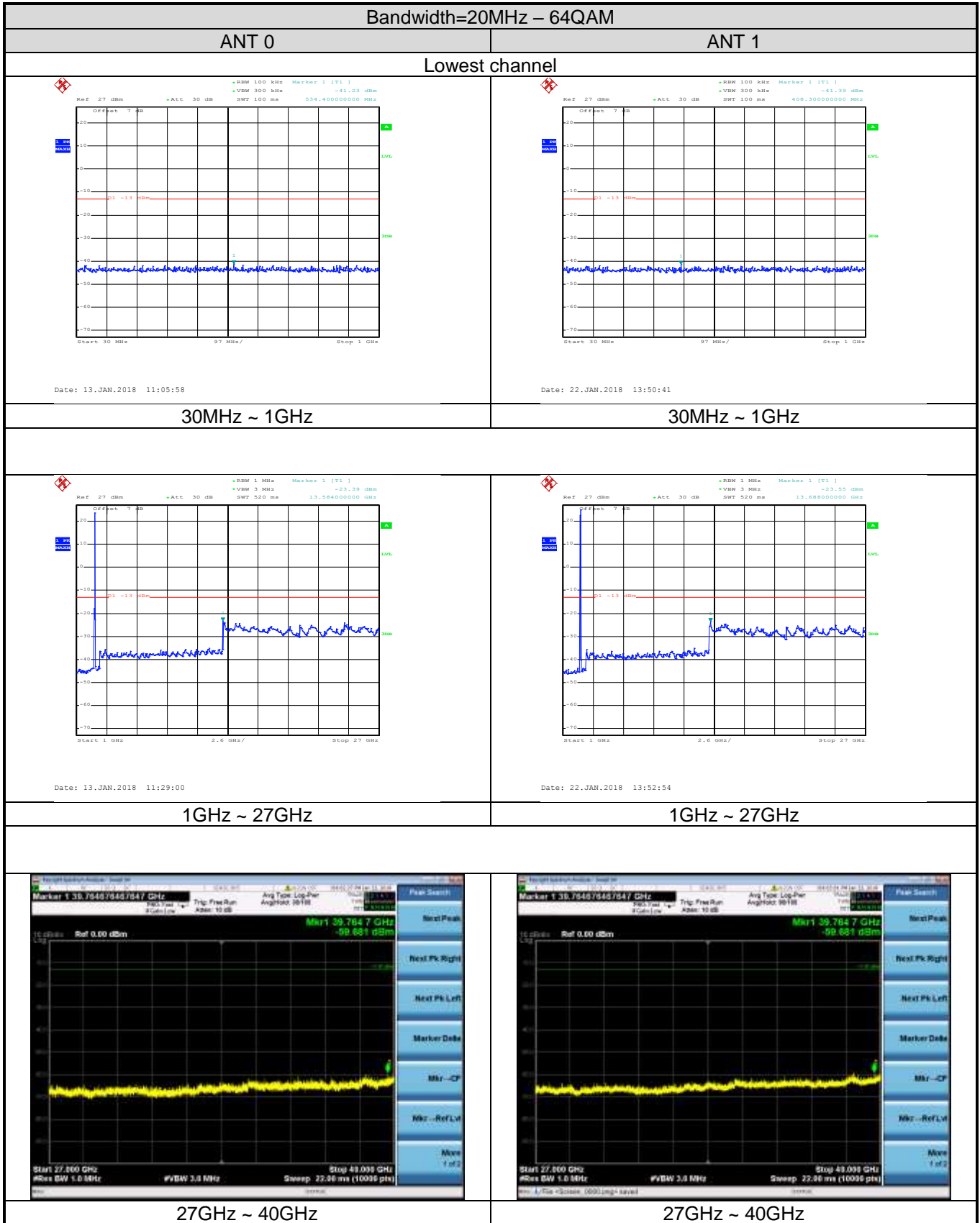

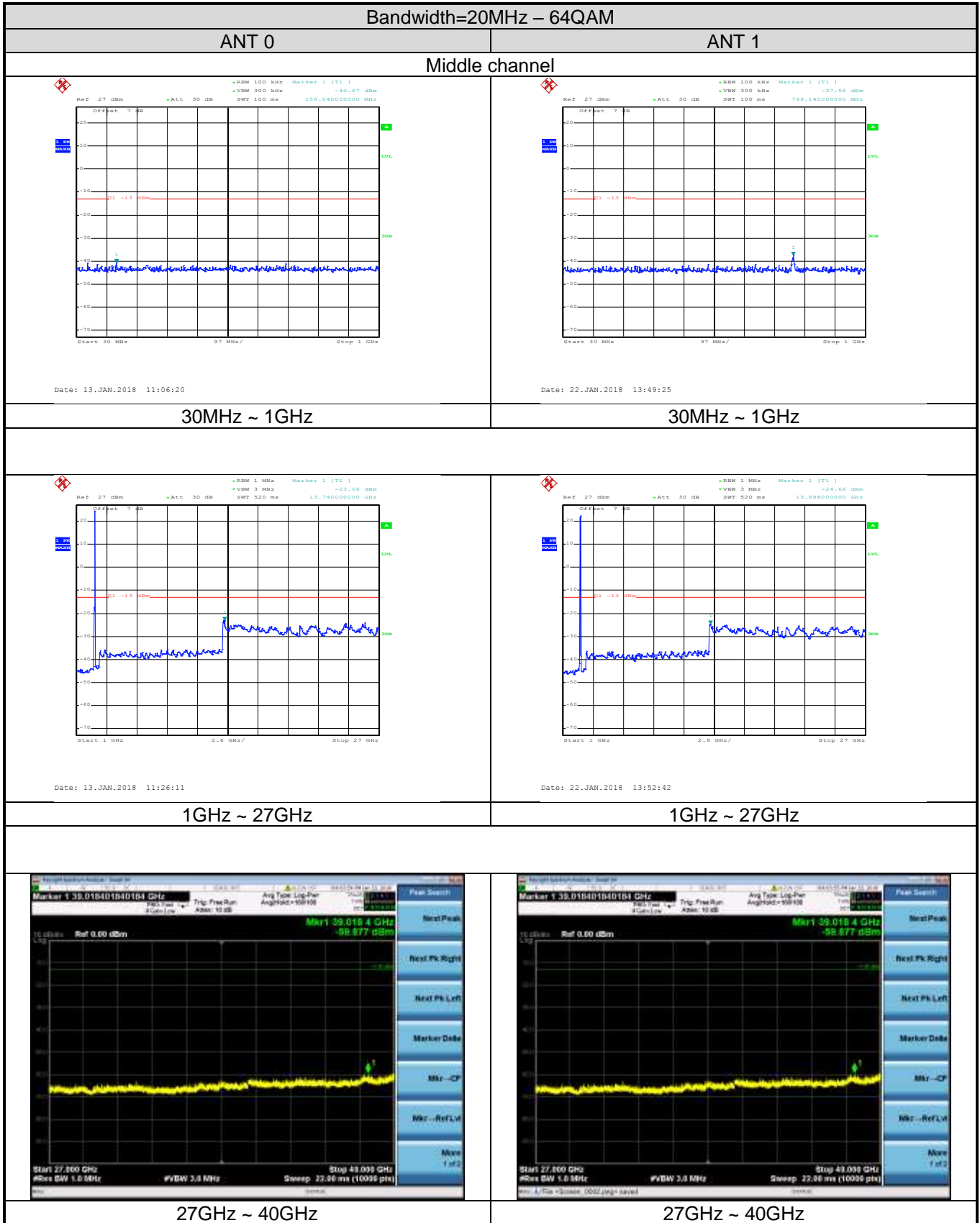

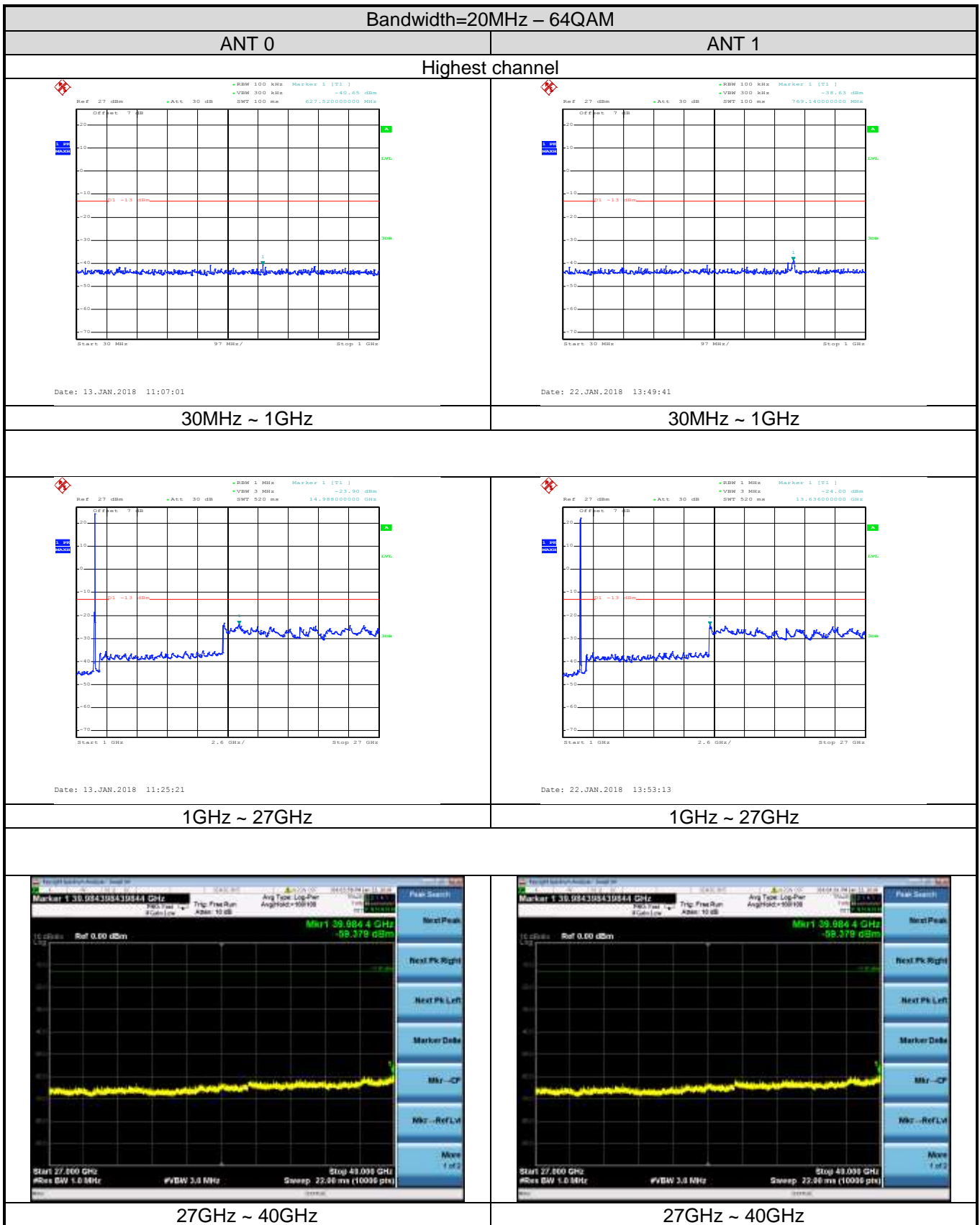

For IC test plot as follows:

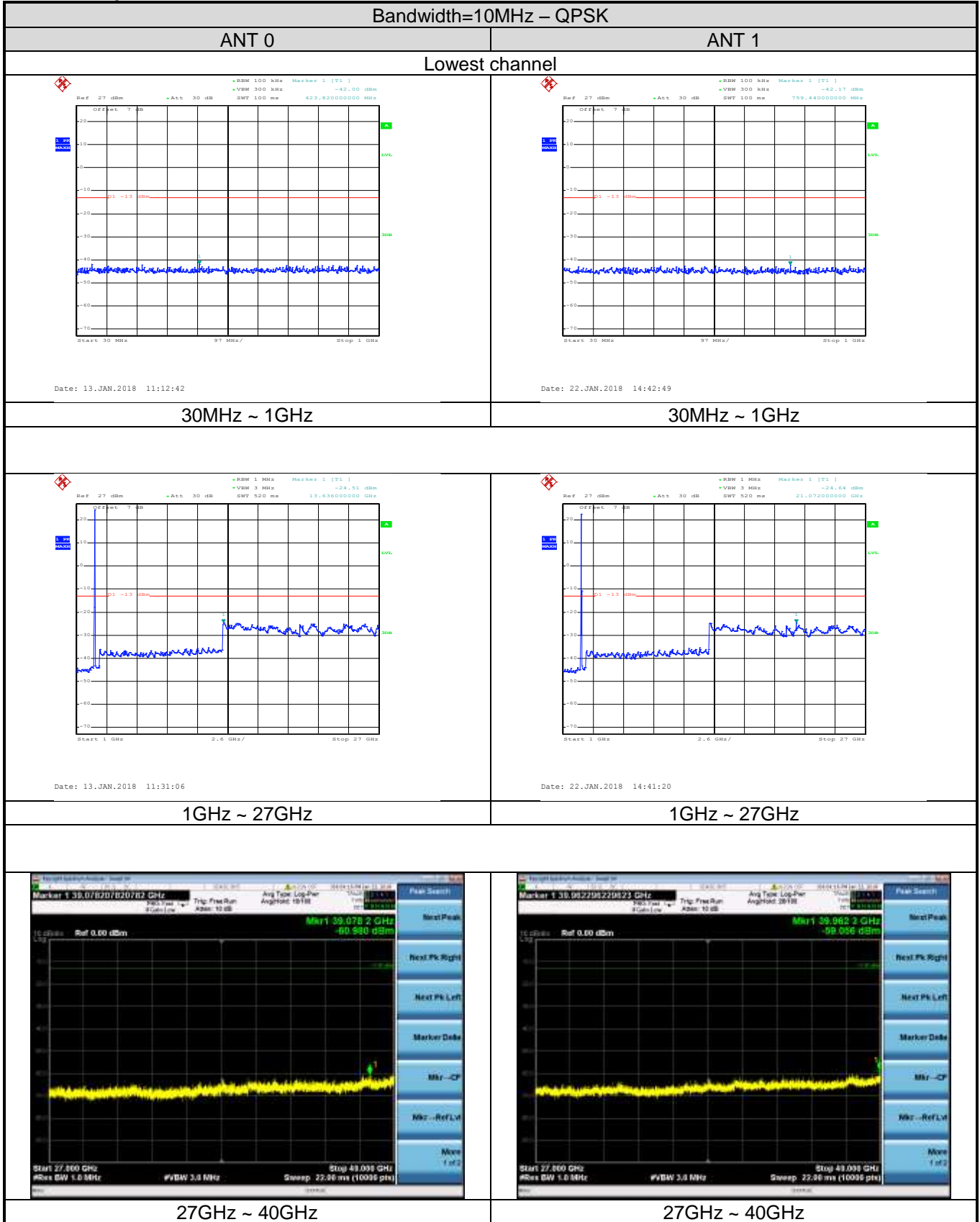



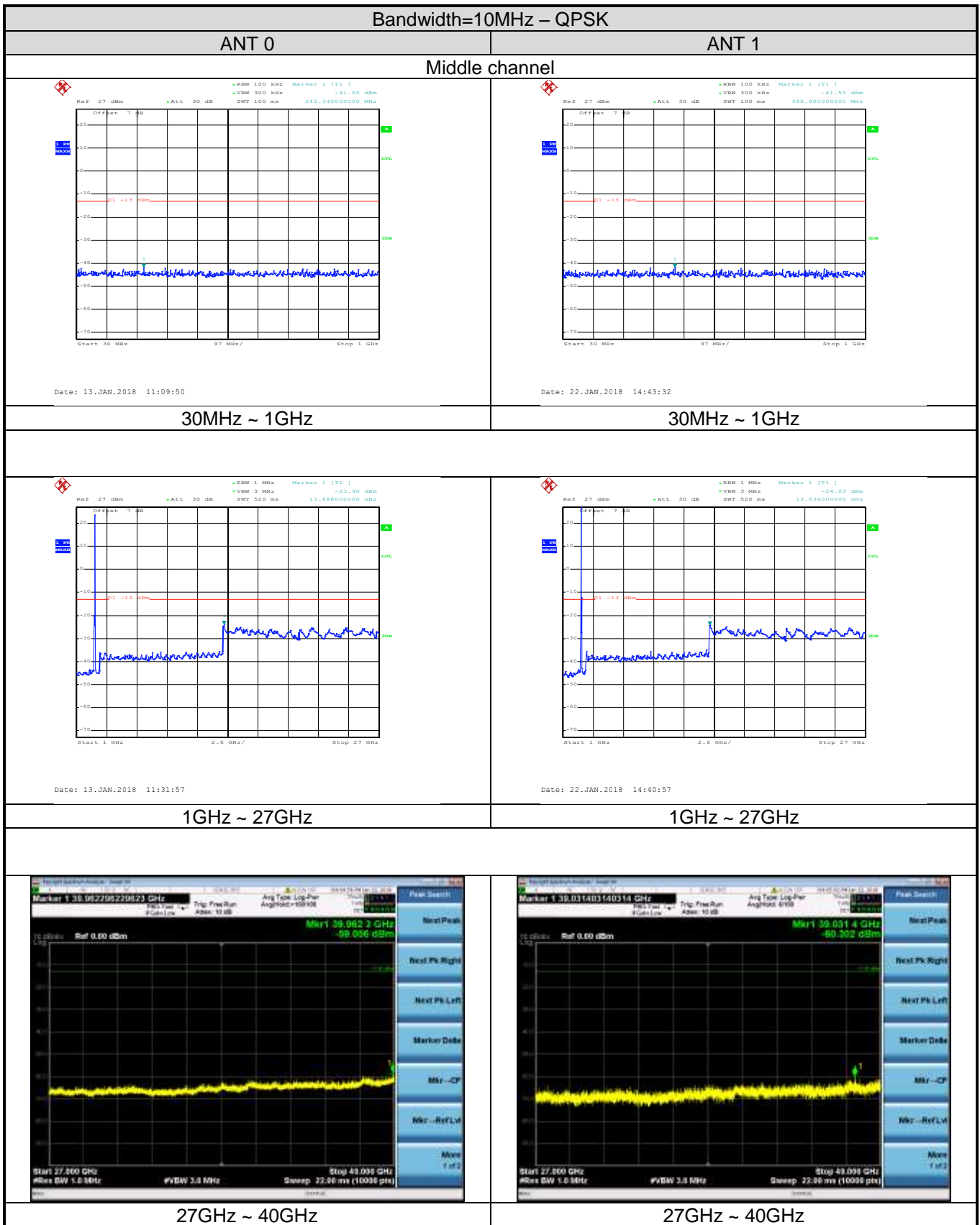

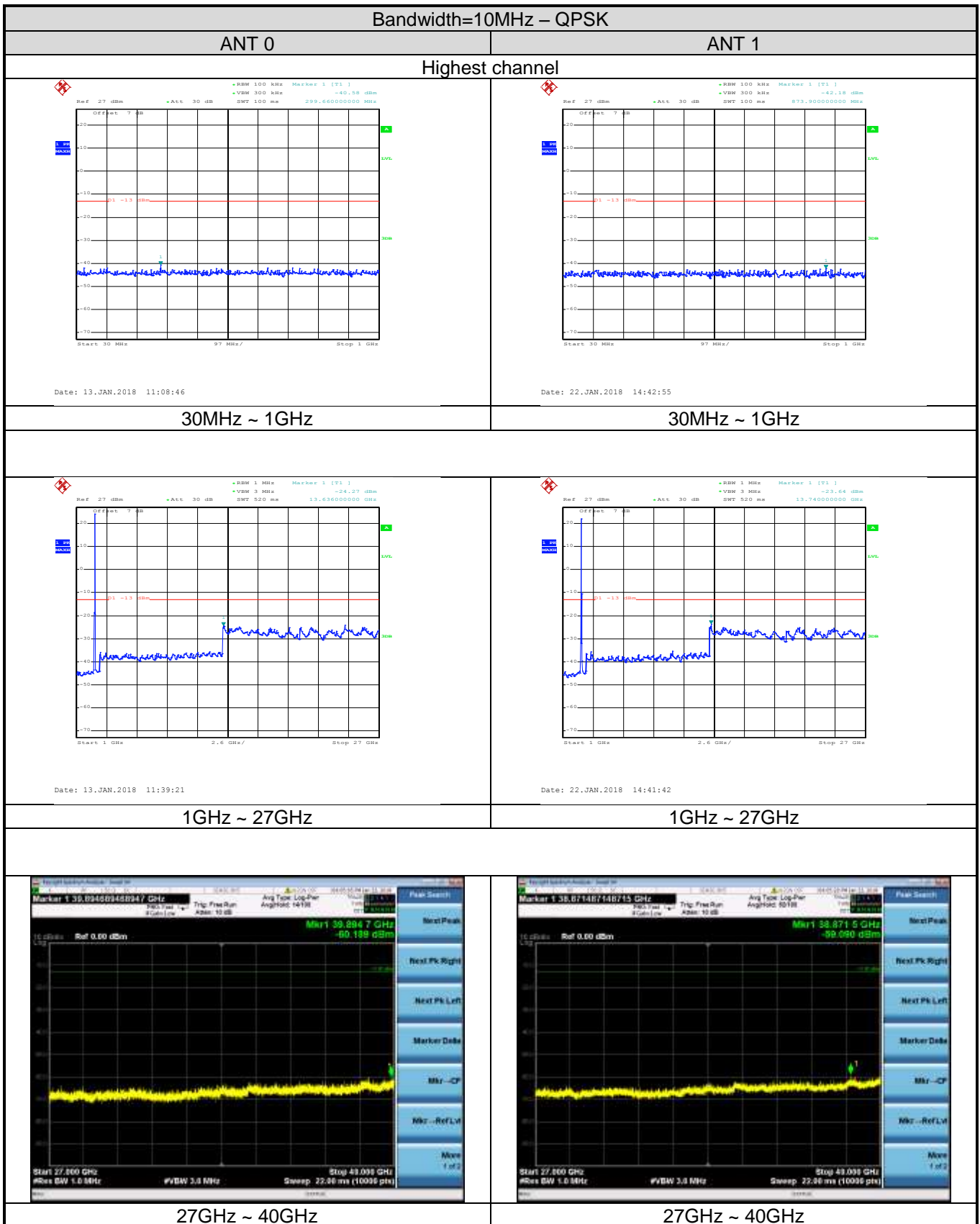

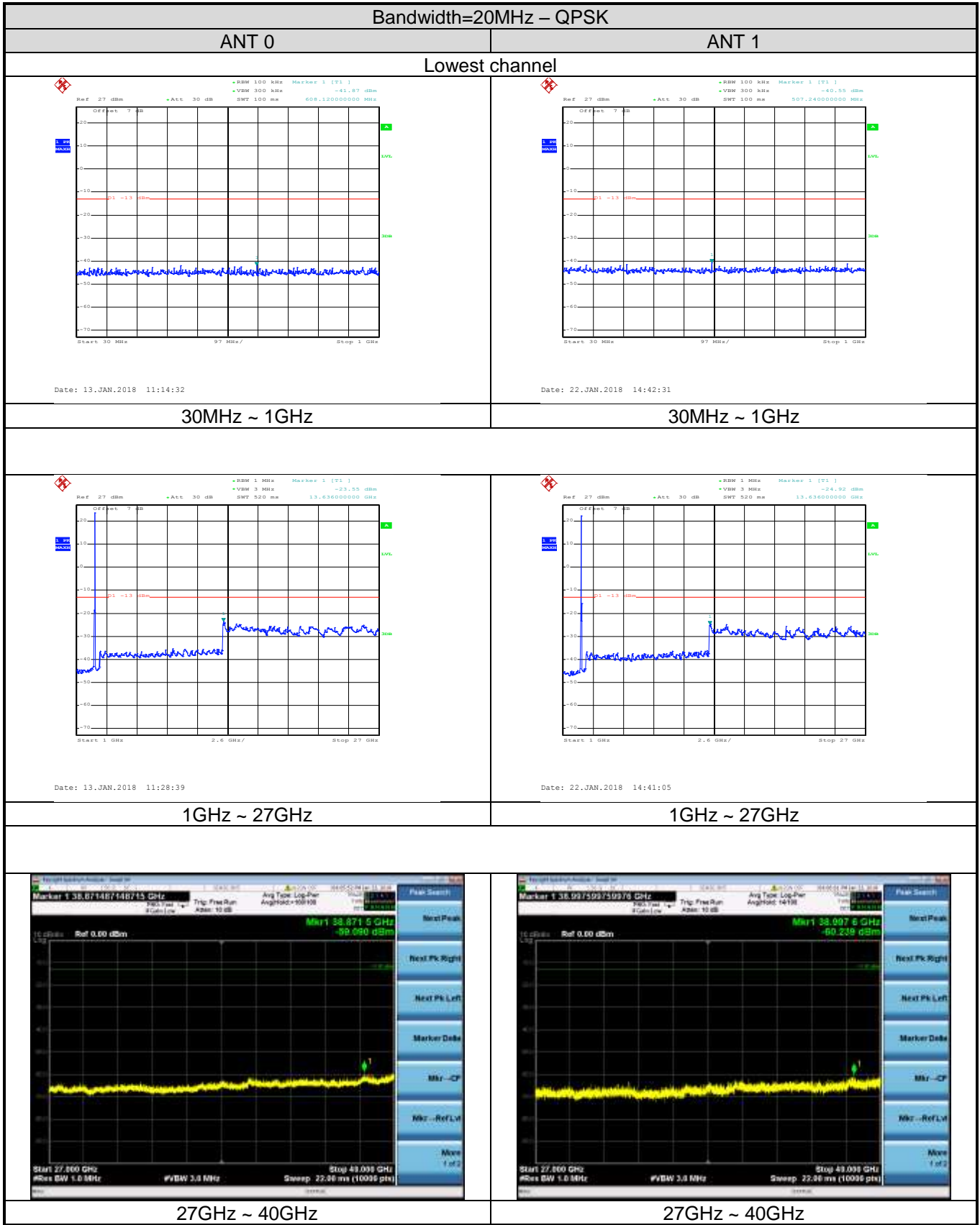

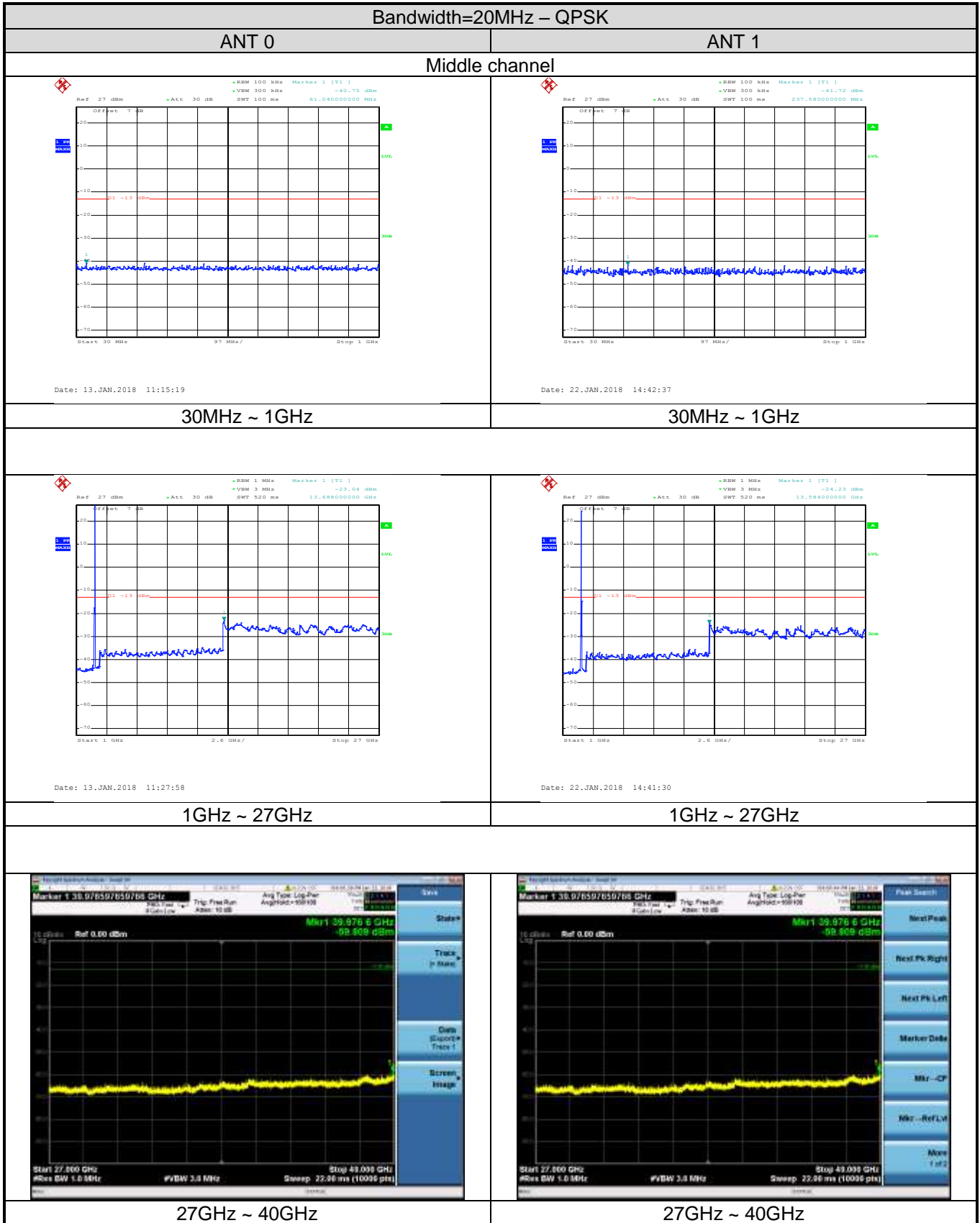

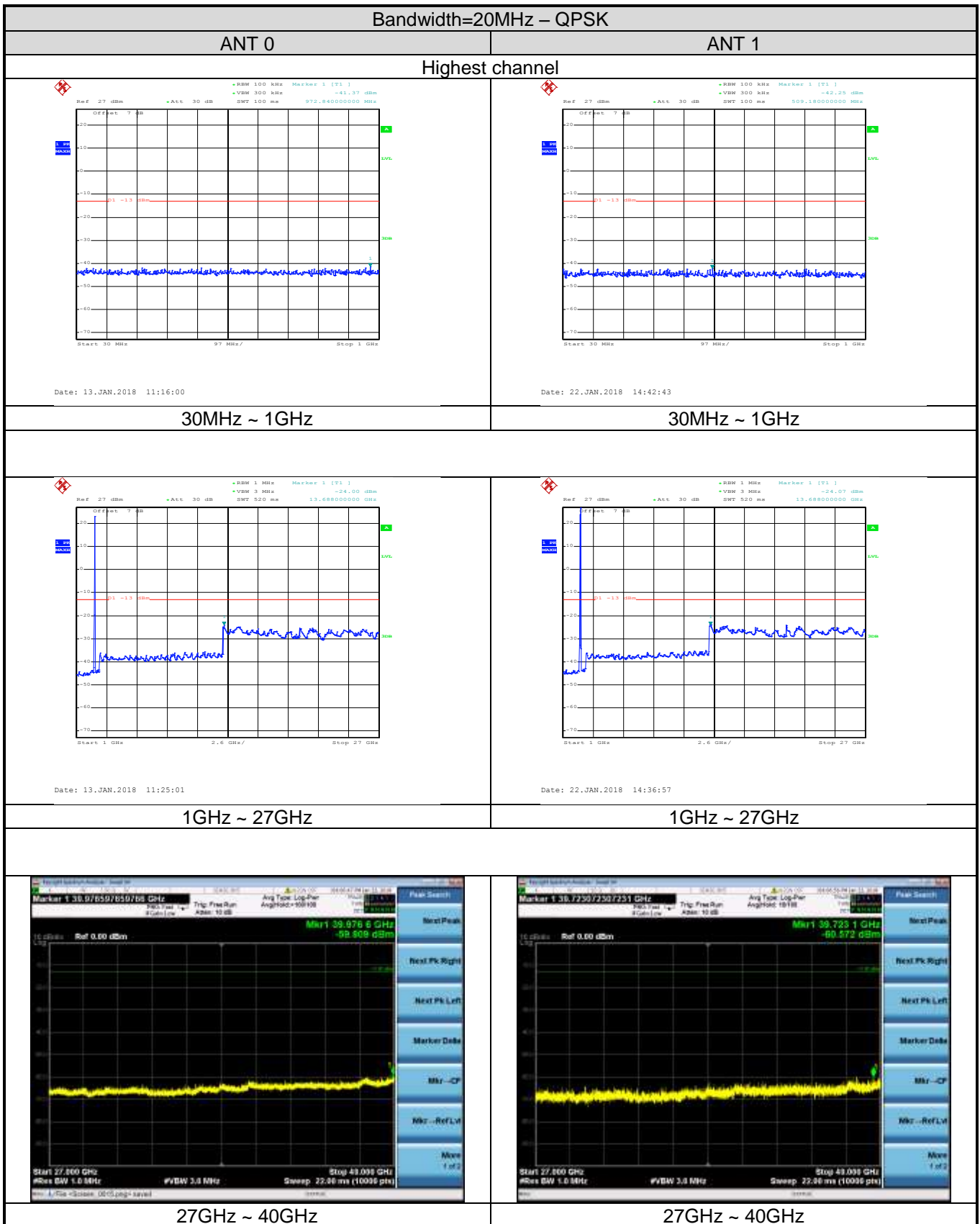

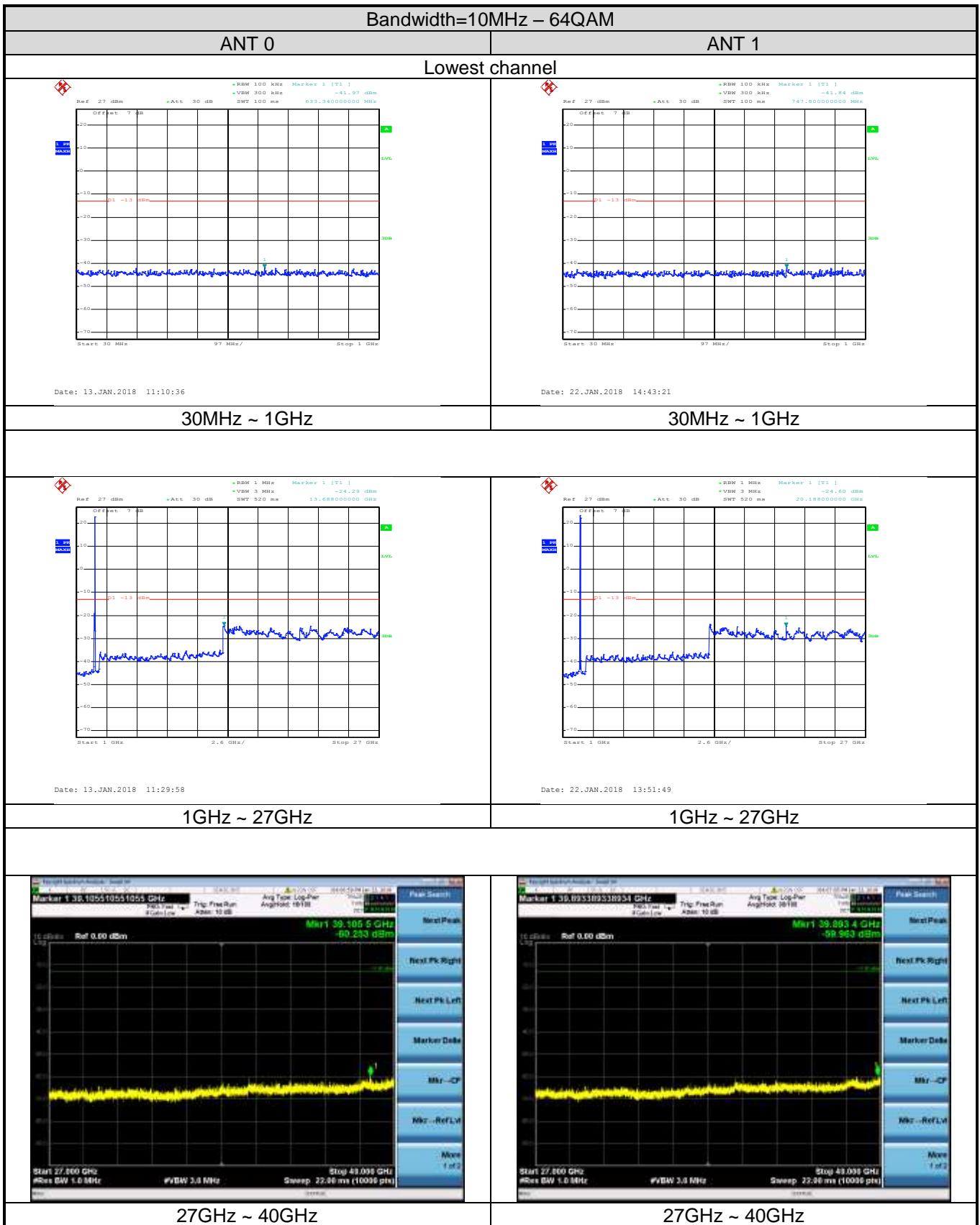

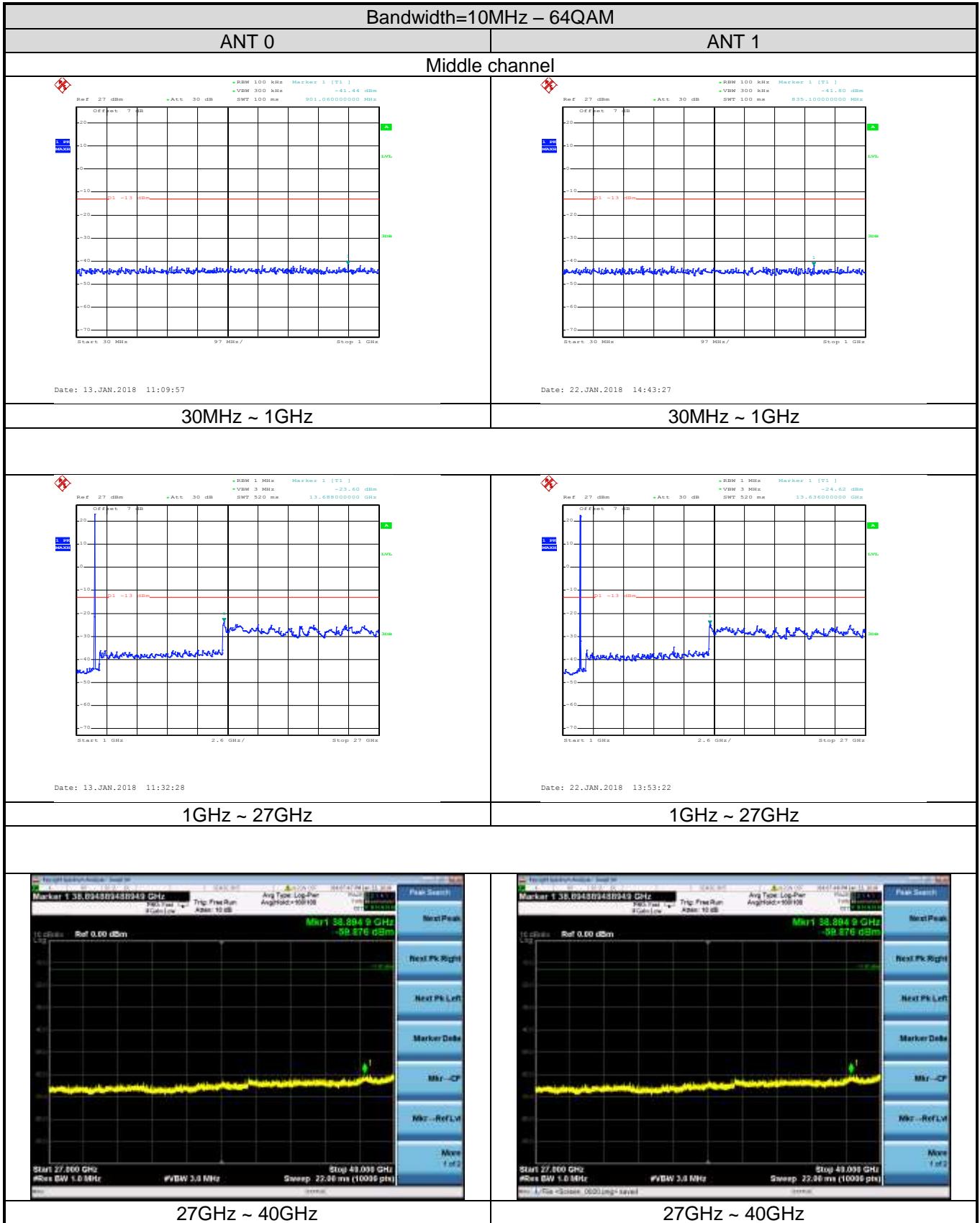

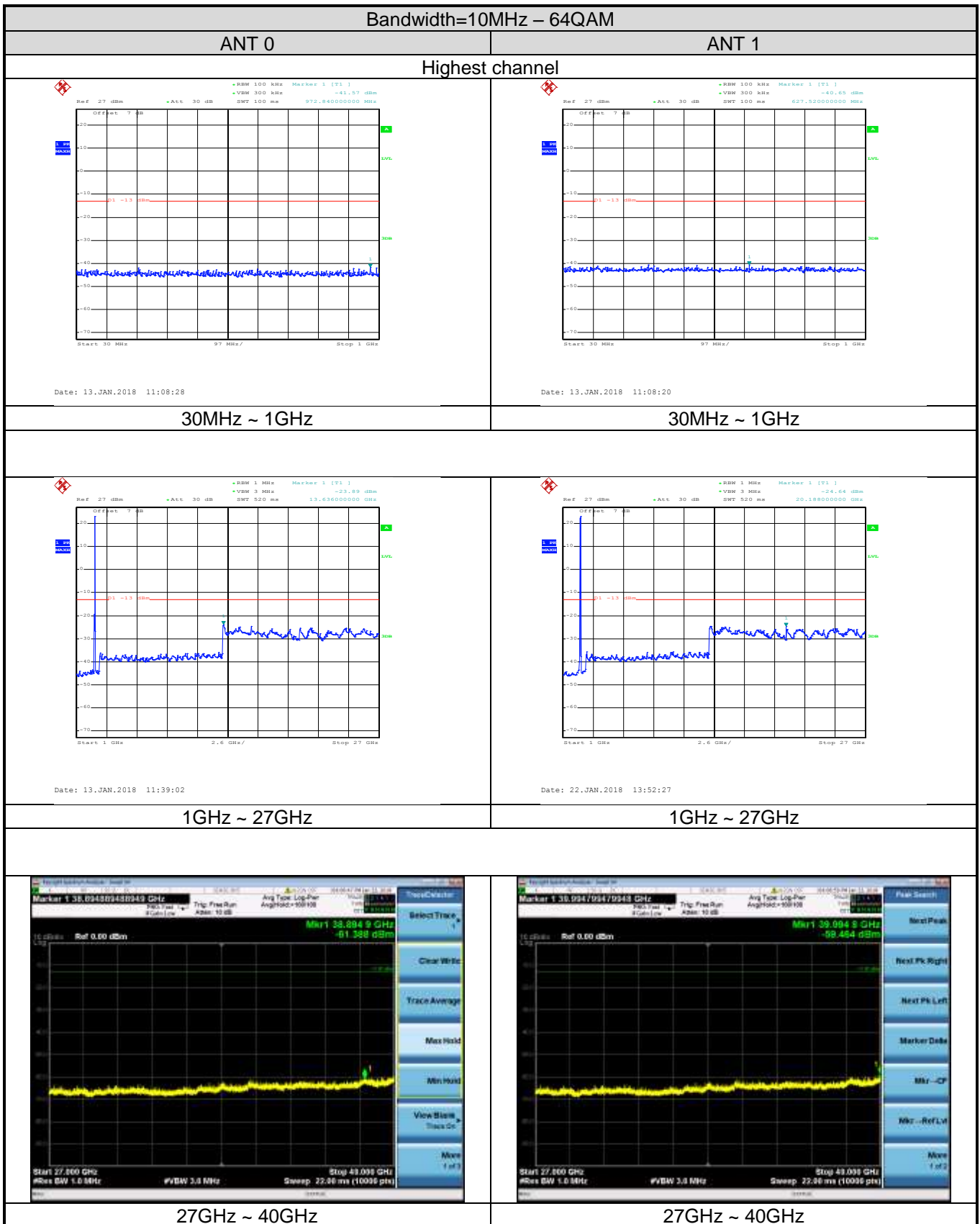



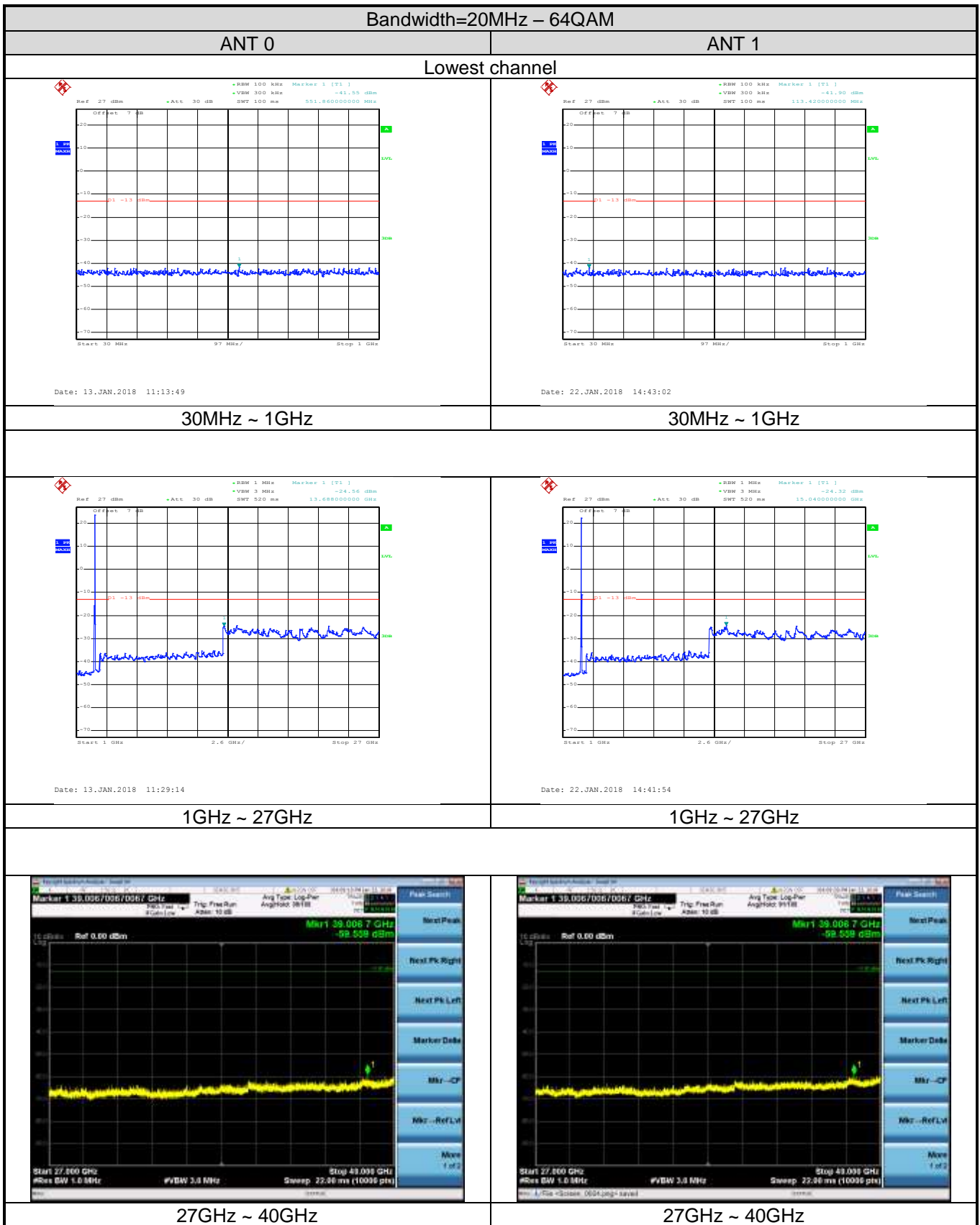

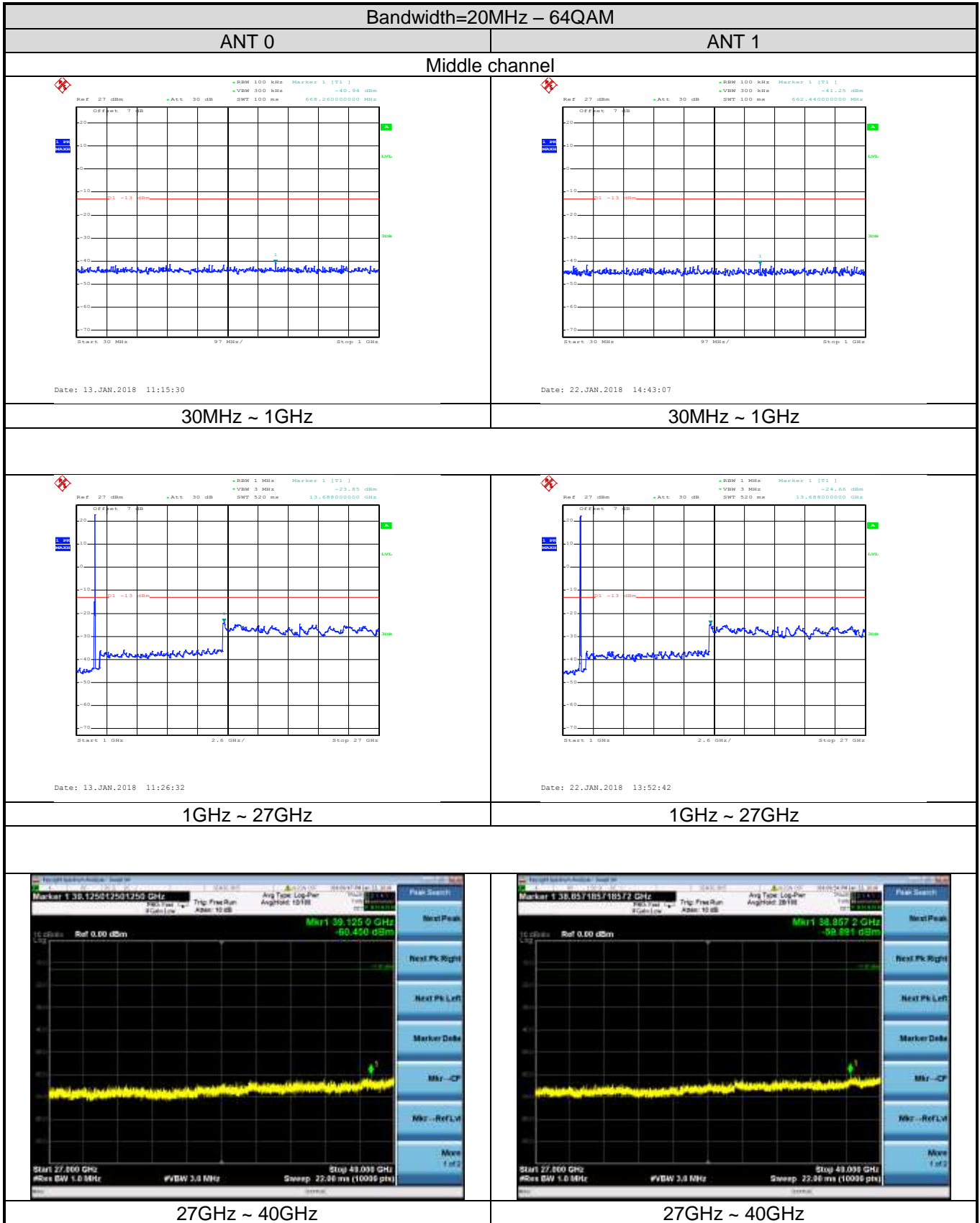

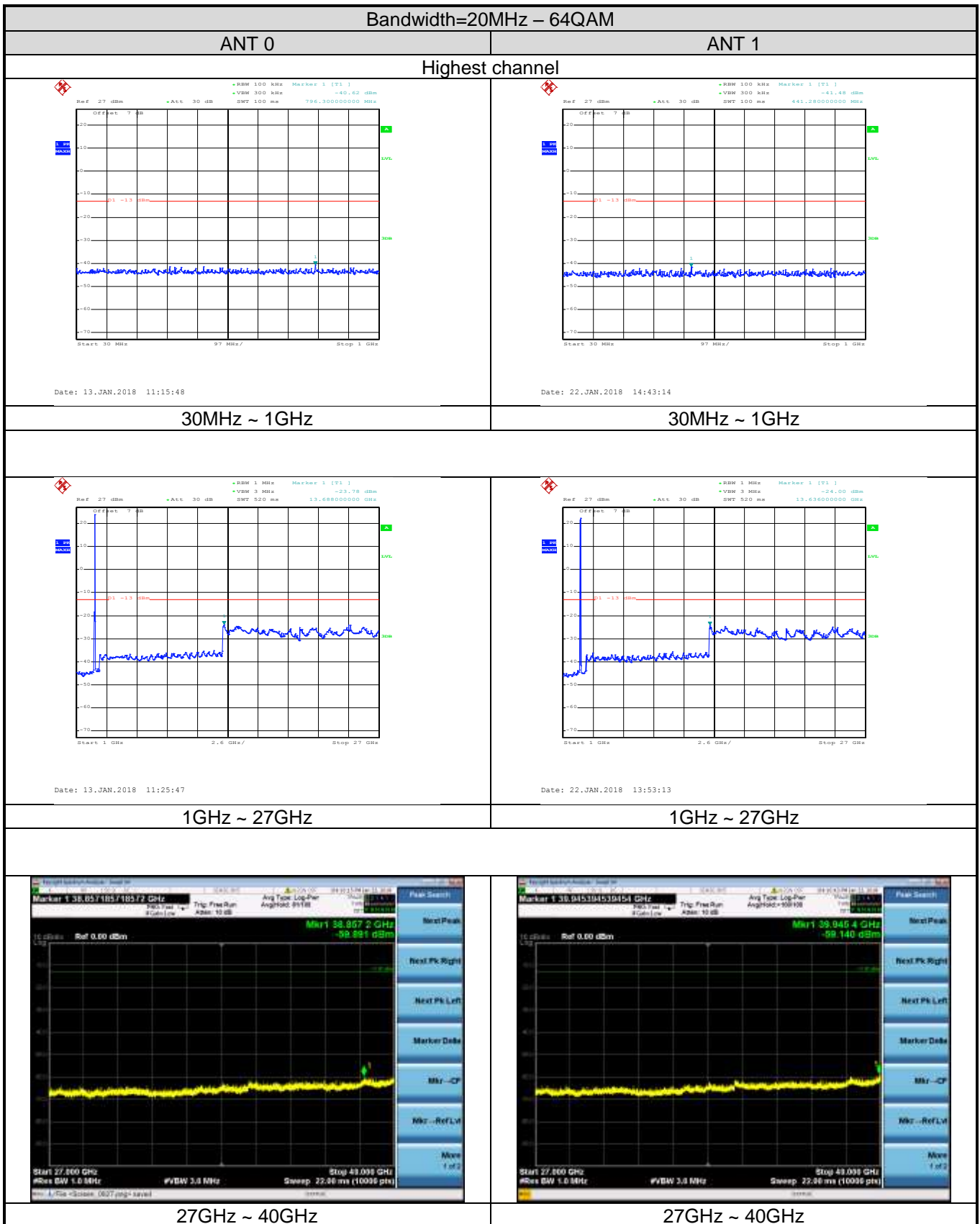

**Band edge emission:  
For FCC test plot:**



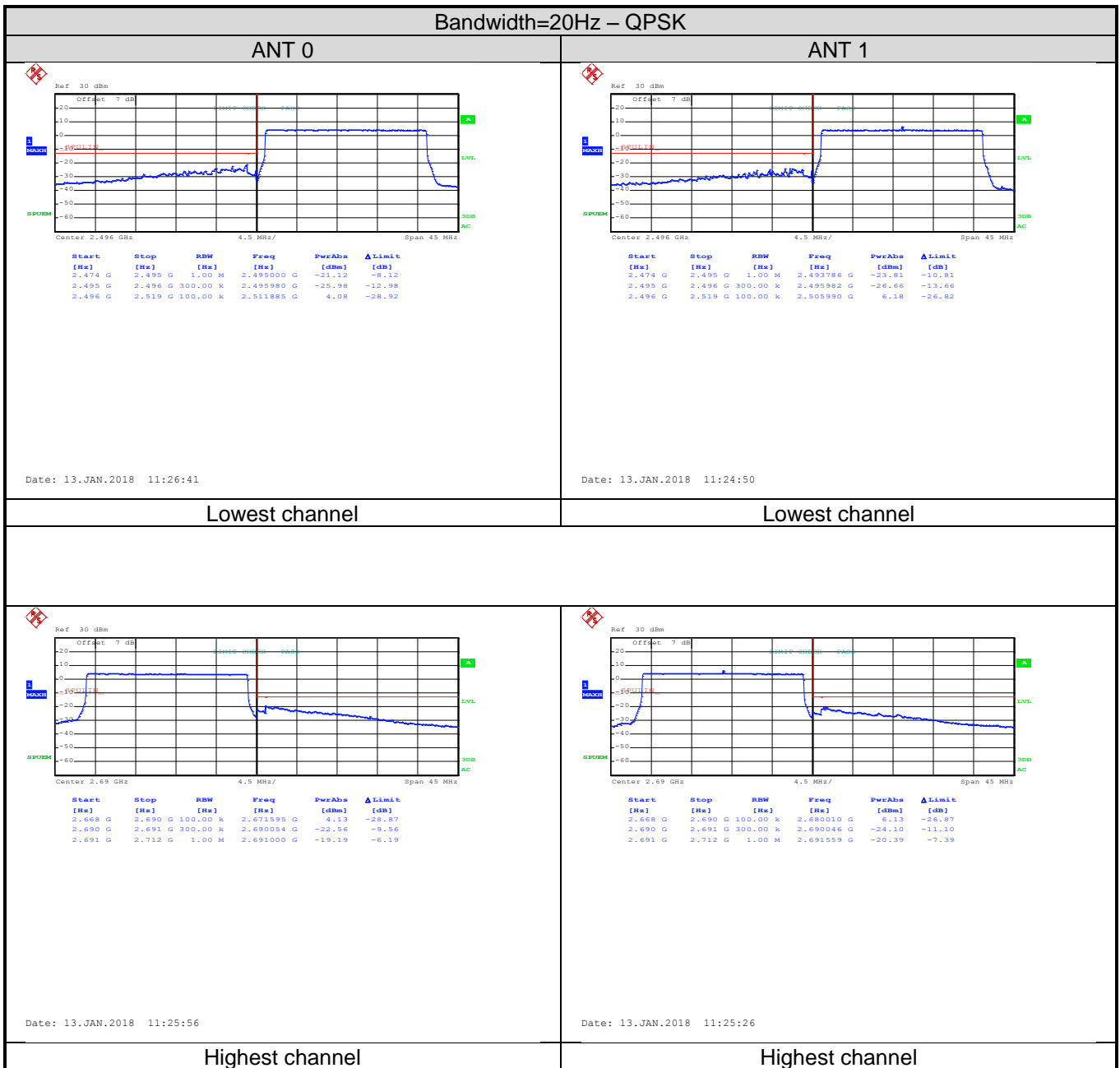

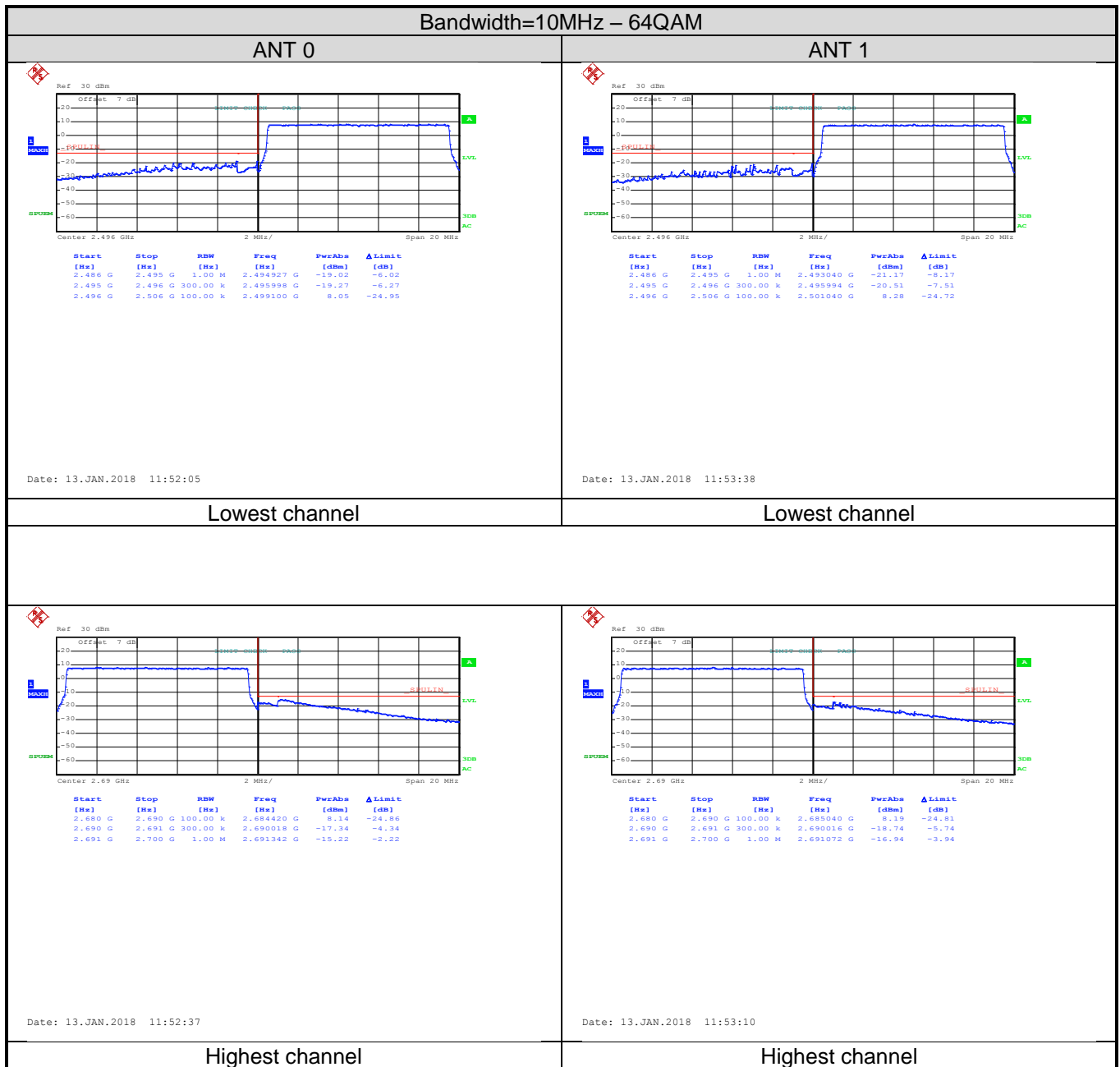

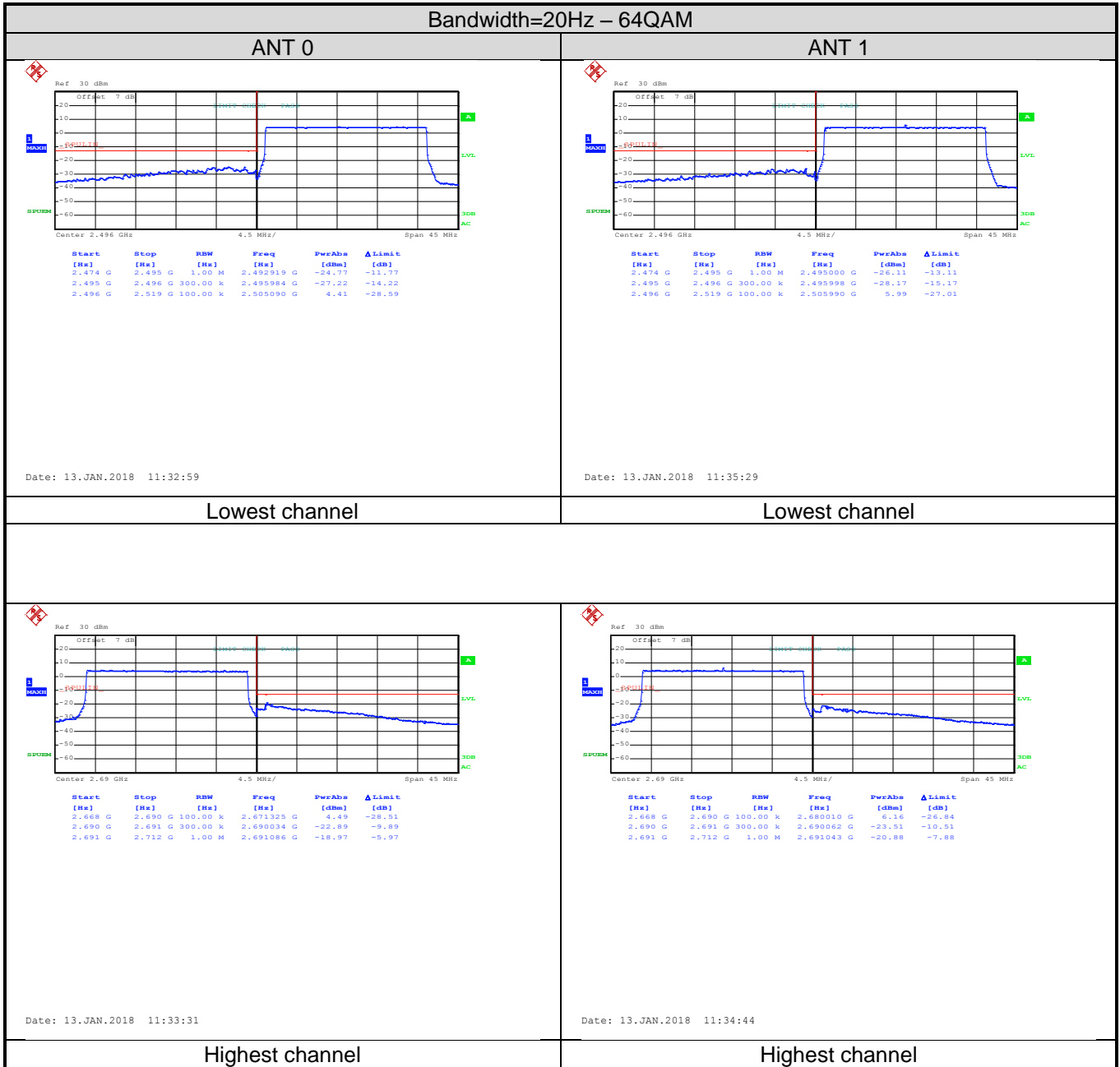

For IC test plot:

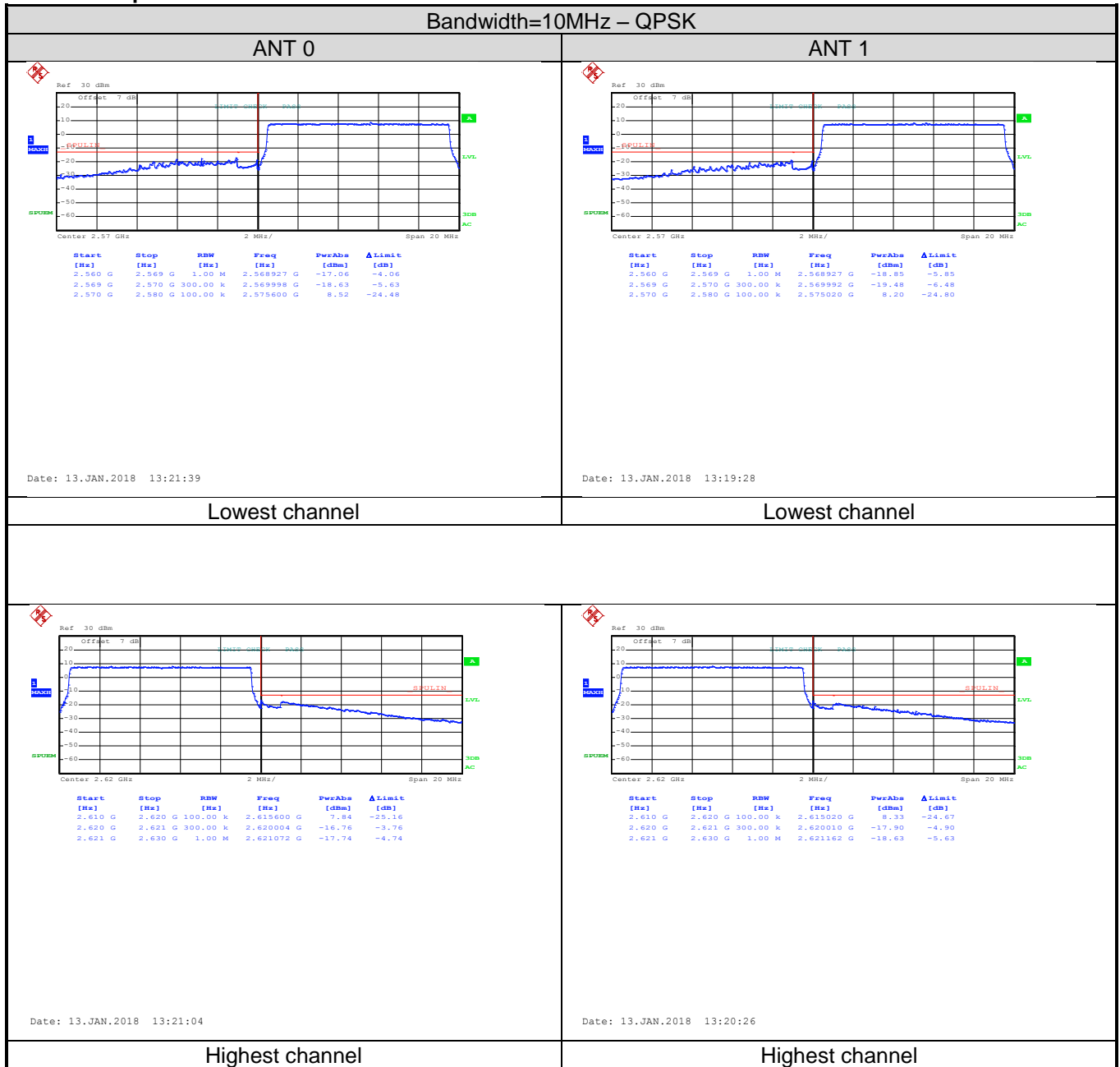



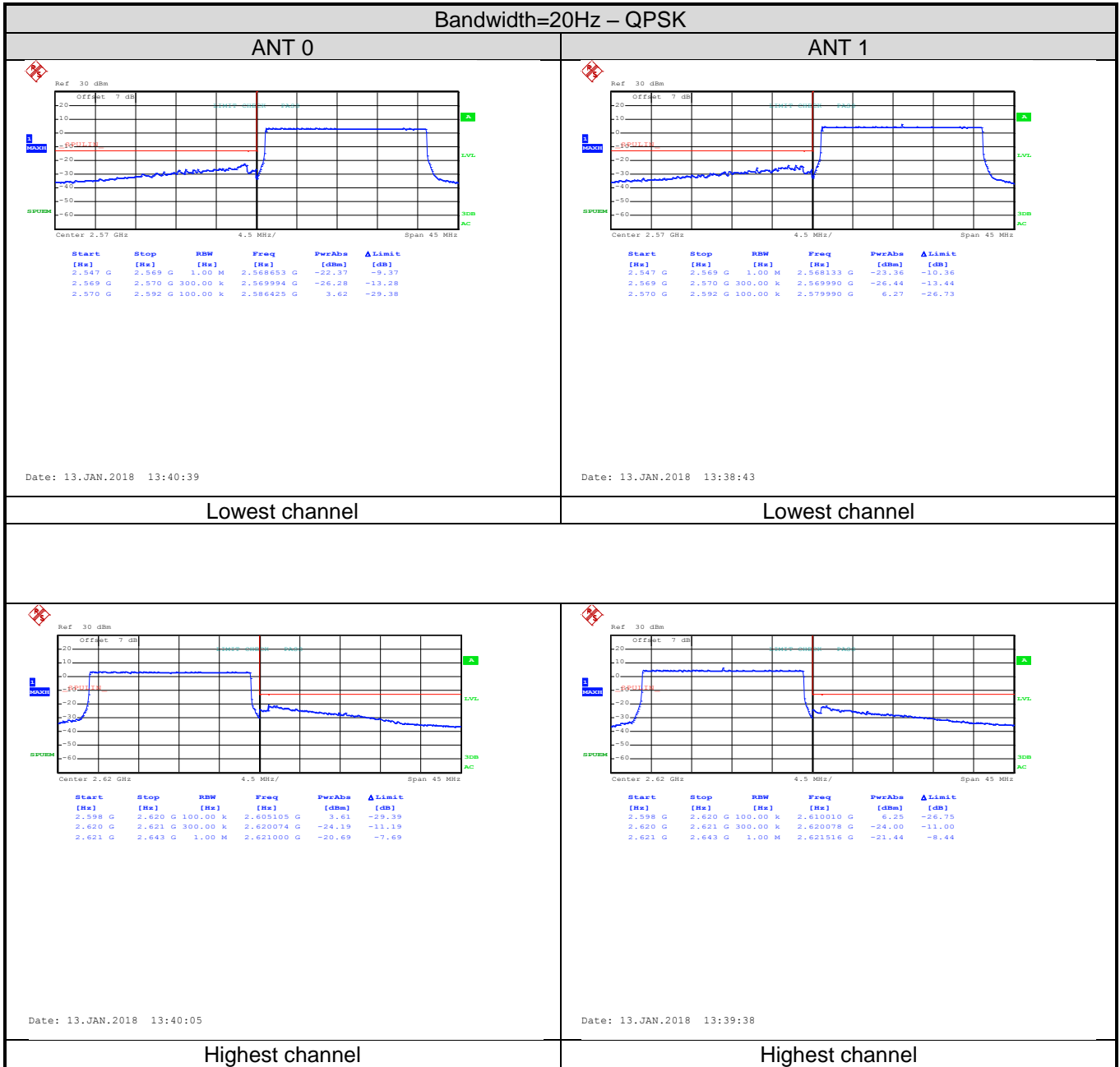

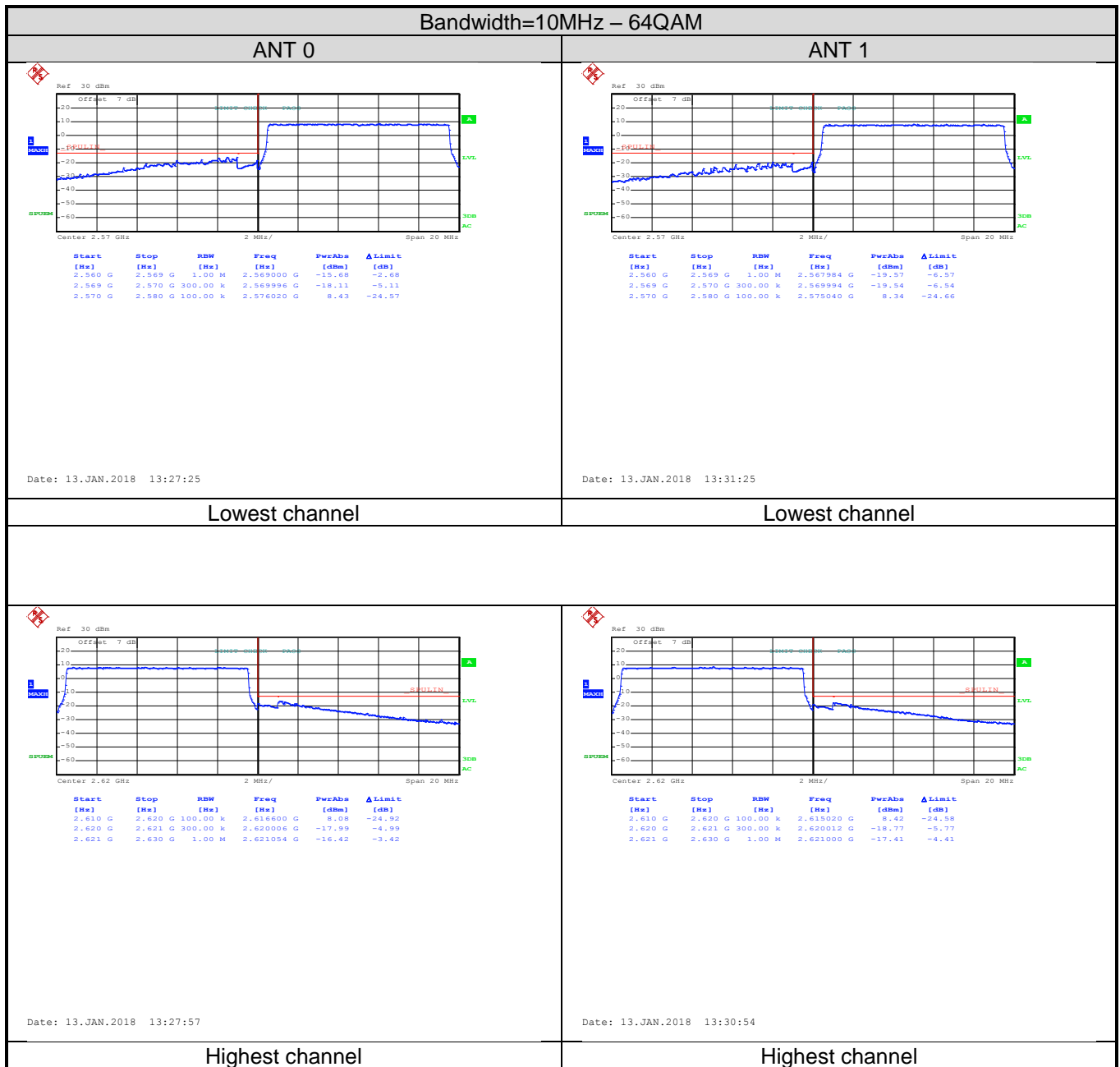

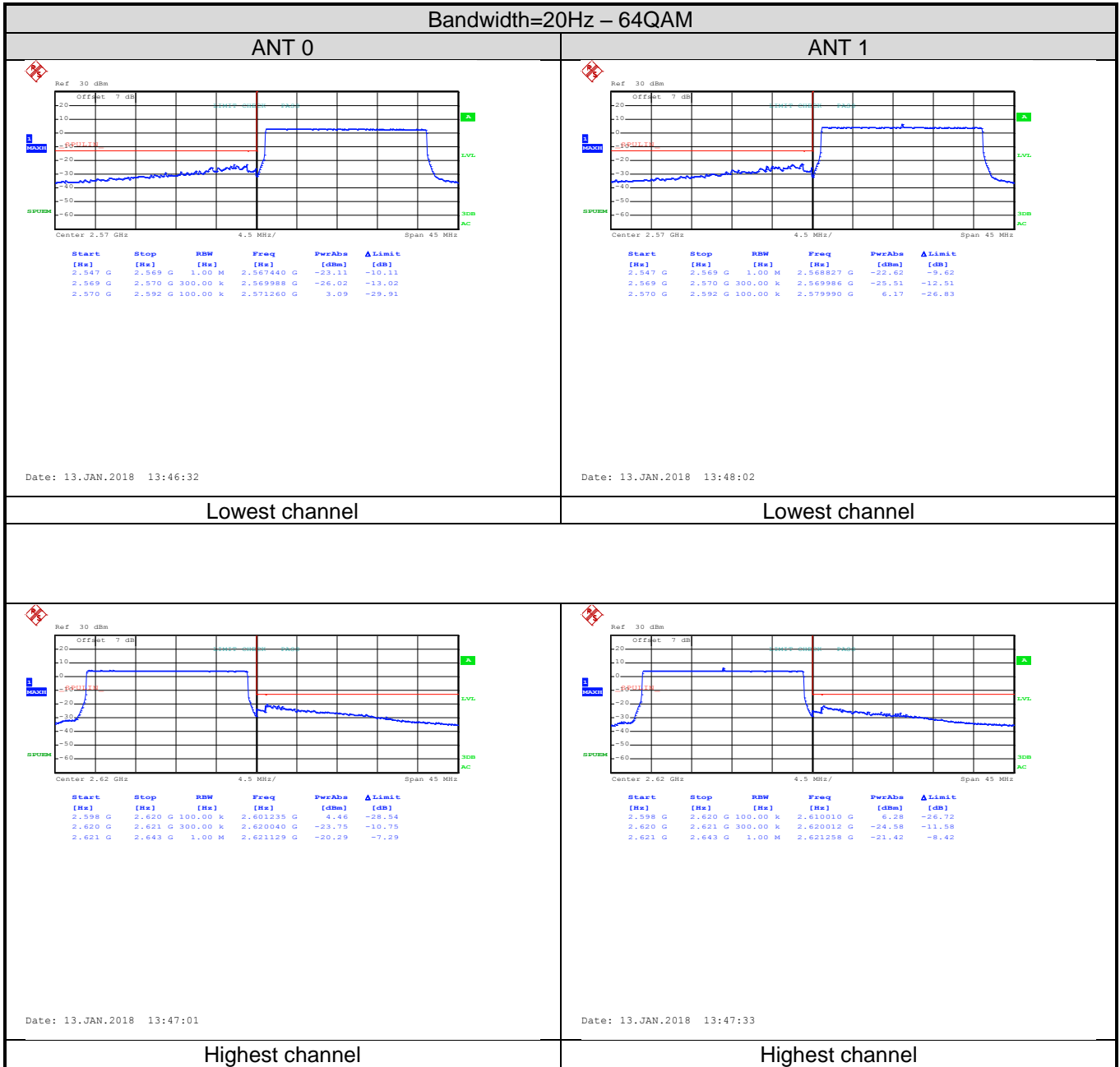

## 6.5 Field strength of spurious radiation measurement

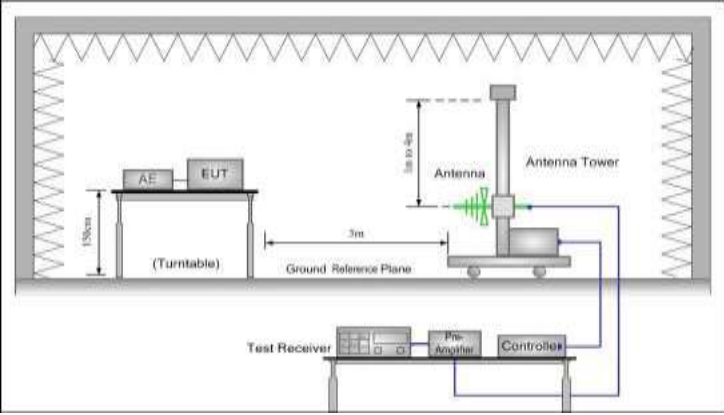
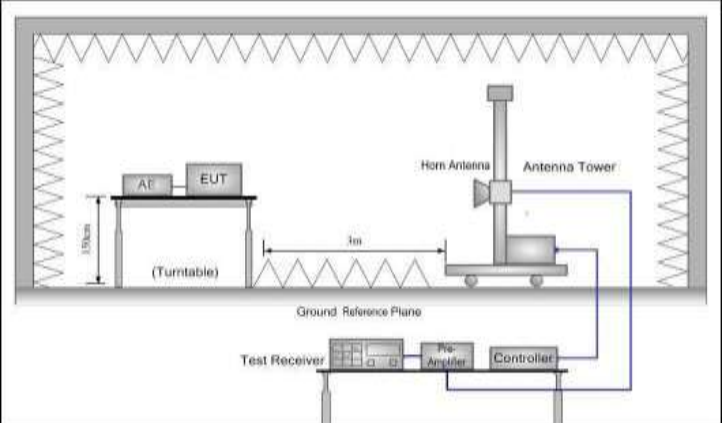
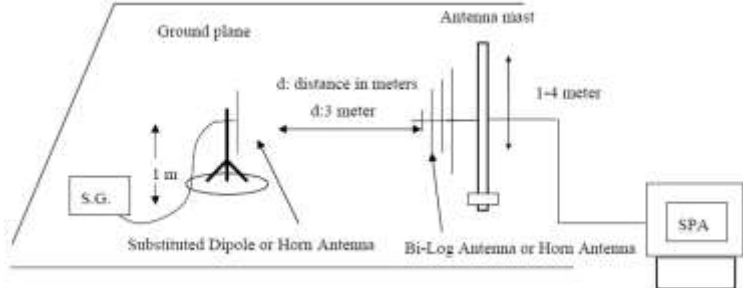
Test Requirement:	Part 27.53(m)(2) and RSS-199 Section 4.5(a)
Test Method:	FCC part 2.1053 and RSS-Gen Section 6.13
Limit:	-13dBm
Test setup:	<p>Below 1GHz</p>  <p>Above 1GHz</p>  <p>Substituted method:</p> 
Test Procedure:	<ol style="list-style-type: none"> <li>1. The EUT was placed on an non-conductive turntable using a non-conductive support. The radiated emission at the fundamental frequency was measured at 3 m with a test antenna and EMI spectrum analyzer.</li> <li>2. During the tests, the antenna height and the EUT azimuth were varied in order to identify the maximum level of emissions from the EUT. This maximization process was repeated with the EUT positioned in each of its three orthogonal orientations.</li> <li>3. The frequency range up to tenth harmonic was investigated for each</li> </ol>

	<p>of three fundamental frequency (low, middle and high channels). Once spurious emission was identified, the power of the emission was determined using the substitution method.</p> <p>4. The spurious emissions attenuation was calculated as the difference between radiated power at the fundamental frequency and the spurious emissions frequency.</p> $\text{ERP / EIRP} = \text{S.G. output (dBm)} + \text{Antenna Gain(dB/dBi)} - \text{Cable Loss (dB)}$
Test Instruments:	Refer to section 5.9 for details
Test mode:	Refer to section 5.3 for details.
Test results:	Passed

**Measurement Data:**

**For FCC test data (worst case):**

Bandwidth=10MHz for QPSK				
Frequency (MHz)	Spurious Emission		Limit (dBm)	Result
	Polarization	Level (dBm)		
Lowest channel				
5002.00	Vertical	-50.12	-13	Pass
7503.00	V	-39.24		
5002.00	Horizontal	-49.12		
7503.00	H	-38.54		
Middle channel				
5186.00	Vertical	-49.37	-13	Pass
7779.00	V	-36.73		
5186.00	Horizontal	-43.51		
7779.00	H	-37.12		
Highest channel				
5370.00	Vertical	-47.22	-13	Pass
8055.00	V	-35.70		
5370.00	Horizontal	-47.63		
8055.00	H	-36.55		
Bandwidth=20MHz for QPSK				
Frequency (MHz)	Spurious Emission		Limit (dBm)	Result
	Polarization	Level (dBm)		
Lowest channel				
5012.00	Vertical	-50.01	-13	Pass
7518.00	V	-38.98		
5012.00	Horizontal	-49.33		
7518.00	H	-38.77		
Middle channel				
5186.00	Vertical	-49.63	-13	Pass
7779.00	V	-36.99		
5186.00	Horizontal	-43.68		
7779.00	H	-37.58		
Highest channel				
5360.00	Vertical	-47.36	-13	Pass
8040.00	V	-35.98		
5360.00	Horizontal	-47.76		
8040.00	H	-36.11		
<p><i>Remark:</i></p> <ol style="list-style-type: none"> <li><i>The emission levels of below 1 GHz are very lower than the limit and not show in test report.</i></li> <li><i>Pre-scan QPSK and 64QAM modulation mode, and found the QPSK modulation mode is the worst case. So the worst case shown in report.</i></li> </ol>				

**For IC test data (worst case):**

Bandwidth=10MHz for QPSK				
Frequency (MHz)	Spurious Emission		Limit (dBm)	Result
	Polarization	Level (dBm)		
Lowest channel				
5150.00	Vertical	-48.47	-13	Pass
7725.00	V	-39.53		
5150.00	Horizontal	-48.86		
7725.00	H	-39.48		
Middle channel				
5190.00	Vertical	-49.12	-13	Pass
7785.00	V	-36.57		
5190.00	Horizontal	-46.23		
7785.00	H	-38.69		
Highest channel				
5230.00	Vertical	-47.36	-13	Pass
7845.00	V	-36.85		
5230.00	Horizontal	-47.39		
7845.00	H	-36.58		
Bandwidth=20MHz for QPSK				
Frequency (MHz)	Spurious Emission		Limit (dBm)	Result
	Polarization	Level (dBm)		
Lowest channel				
5160.00	Vertical	-49.23	-13	Pass
7740.00	V	-40.02		
5160.00	Horizontal	-49.11		
7740.00	H	-38.27		
Middle channel				
5190.00	Vertical	-49.23	-13	Pass
7785.00	V	-36.47		
5190.00	Horizontal	-46.17		
7785.00	H	-38.23		
Highest channel				
5220.00	Vertical	-47.22	-13	Pass
7830.00	V	-36.03		
5220.00	Horizontal	-47.12		
7830.00	H	-36.36		
<p><b>Remark:</b></p> <ol style="list-style-type: none"> <li>The emission levels of below 1 GHz are very lower than the limit and not show in test report.</li> <li>Pre-scan QPSK and 64QAM modulation mode, and found the QPSK modulation mode is the worst case. So the worst case shown in report.</li> </ol>				

## 6.6 Frequency stability V.S. Temperature measurement

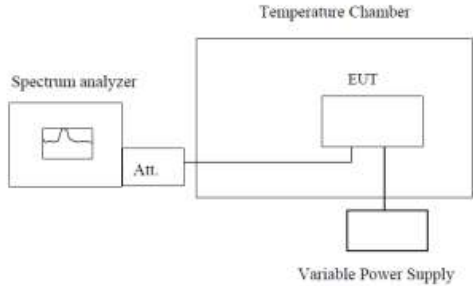
Test Requirement:	Part 27.54 and RSS-199 Section 4.3
Test Method:	FCC Part 2.1055(a)(1)(b) and RSS-Gen Section 6.11
Limit:	<p>FCC: The frequency stability shall be sufficient to ensure that the fundamental emissions stay within the authorized bands of operation.</p> <p>IC: Using a resolution bandwidth equal to that permitted within the 1 MHz band immediately outside the channel edge, as found in section 4.5, reference points will be selected at the unwanted emission limits, which comply with the attenuation specified in section 4.5 for the type of device under test, on the emission mask of the lowest and highest channels. The frequency at these points shall be recorded as <math>f_L</math> and <math>f_H</math> respectively.</p>
Test setup:	 <p style="text-align: center;">Note : Measurement setup for testing on Antenna connector</p>
Test procedure:	<ol style="list-style-type: none"> <li>1. The equipment under test was connected to an external DC power supply and input rated voltage.</li> <li>2. RF output was connected to a frequency counter or spectrum analyzer via feed through attenuators.</li> <li>3. The EUT was placed inside the temperature chamber.</li> <li>4. Set the spectrum analyzer RBW low enough to obtain the desired frequency resolution and measure EUT 25°C operating frequency as reference frequency.</li> <li>5. Turn EUT off and set the chamber temperature to -30°C. After the temperature stabilized for approximately 30 minutes recorded the frequency.</li> <li>6. Repeat step measure with 10°C increased per stage until the highest temperature of +50°C reached</li> </ol>
Test Instruments:	Refer to section 5.9 for details
Test mode:	Refer to section 5.3 for details
Test results:	Passed
Remark:	All three channels of all modulations have been tested, but only the worst channel and the worst modulation show in this test item.



**Measurement Data:**  
**For FCC test data (worst channel):**

Reference Frequency: Lowest channel=2501.0MHz(10MHz for QPSK)			
Power supplied (Vac)	Temperature (°C)	Frequency error	
		Hz	ppm
120	-30	185	0.073970
	-20	177	0.070772
	-10	160	0.063974
	0	145	0.057977
	10	142	0.056777
	20	138	0.055178
	30	128	0.051180
	40	162	0.064774
	50	140	0.055978
Reference Frequency: Lowest channel=2506.0MHz(20MHz for QPSK)			
Power supplied (Vac)	Temperature (°C)	Frequency error	
		Hz	ppm
120	-30	184	0.073424
	-20	175	0.069832
	-10	169	0.067438
	0	172	0.068635
	10	163	0.065044
	20	155	0.061852
	30	152	0.060654
	40	103	0.041101
	50	128	0.051077
Reference Frequency: Lowest channel=2501.0MHz(10MHz for 64QAM)			
Power supplied (Vac)	Temperature (°C)	Frequency error	
		Hz	ppm
120	-30	174	0.069572
	-20	145	0.057977
	-10	132	0.052779
	0	126	0.050380
	10	108	0.043183
	20	127	0.050780
	30	136	0.054378
	40	159	0.063575
	50	128	0.051180
Reference Frequency: Lowest channel=2506.0MHz(20MHz for 64QAM)			
Power supplied (Vac)	Temperature (°C)	Frequency error	
		Hz	ppm
120	-30	163	0.065044
	-20	120	0.047885
	-10	114	0.045491
	0	126	0.050279
	10	135	0.053871
	20	145	0.057861
	30	140	0.055866
	40	122	0.048683
	50	115	0.045890

**For IC test data (worst channel):**

Reference Frequency: Lowest channel=2575.0MHz(10MHz for QPSK)			
Power supplied (Vac)	Temperature (°C)	Frequency error	
		Hz	ppm
120	-30	189	0.073398
	-20	165	0.064078
	-10	145	0.056311
	0	175	0.067961
	10	163	0.063301
	20	152	0.059029
	30	138	0.053592
	40	128	0.049709
	50	133	0.051650
Reference Frequency: Lowest channel=2580.0MHz(20MHz for QPSK)			
Power supplied (Vac)	Temperature (°C)	Frequency error	
		Hz	ppm
120	-30	152	0.058915
	-20	162	0.062791
	-10	168	0.065116
	0	148	0.057364
	10	175	0.067829
	20	162	0.062791
	30	143	0.055426
	40	155	0.060078
	50	169	0.065504
Reference Frequency: Lowest channel=2575.0MHz(10MHz for 64QAM)			
Power supplied (Vac)	Temperature (°C)	Frequency error	
		Hz	ppm
120	-30	172	0.066796
	-20	165	0.064078
	-10	183	0.071068
	0	192	0.074563
	10	142	0.055146
	20	132	0.051262
	30	128	0.049709
	40	146	0.056699
	50	153	0.059417
Reference Frequency: Lowest channel=2580.0MHz(20MHz for 64QAM)			
Power supplied (Vac)	Temperature (°C)	Frequency error	
		Hz	ppm
120	-30	167	0.064729
	-20	188	0.072868
	-10	150	0.058140
	0	147	0.056977
	10	156	0.060465
	20	135	0.052326
	30	129	0.050000
	40	175	0.067829
	50	166	0.064341

## 6.7 Frequency stability V.S. Voltage measurement

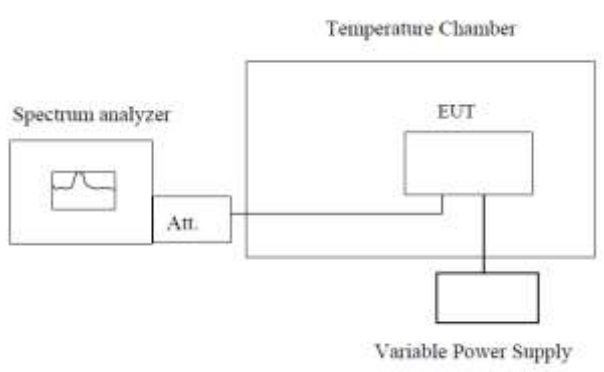
Test Requirement:	Part 27.54 and RSS-199 Section 4.3
Test Method:	FCC Part 2.1055(a)(1)(b) and RSS-Gen Section 6.11
Limit:	<p>FCC: The frequency stability shall be sufficient to ensure that the fundamental emissions stay within the authorized bands of operation.</p> <p>IC: Using a resolution bandwidth equal to that permitted within the 1 MHz band immediately outside the channel edge, as found in section 4.5, reference points will be selected at the unwanted emission limits, which comply with the attenuation specified in section 4.5 for the type of device under test, on the emission mask of the lowest and highest channels. The frequency at these points shall be recorded as <math>f_L</math> and <math>f_H</math> respectively.</p>
Test setup:	 <p><b>Note :</b> Measurement setup for testing on Antenna connector</p>
Test procedure:	<ol style="list-style-type: none"> <li>1. Set chamber temperature to 25°C. Use a variable DC power source to power the EUT and set the voltage to rated voltage.</li> <li>2. Set the spectrum analyzer RBW low enough to obtain the desired frequency resolution and recorded the frequency.</li> <li>3. Reduce the input voltage to specify extreme voltage variation (+/- 15%) and endpoint, record the maximum frequency change.</li> </ol>
Test Instruments:	Refer to section 5.9 for details
Test mode:	Refer to section 5.3 for details
Test results:	Passed
Remark:	All three channels of all modulations have been tested, but only the worst channel and the worst modulation show in this test item.

**Measurement Data:  
For FCC test data (worst channel):**

Reference Frequency: Lowest channel=2501.0MHz(10MHz for QPSK)			
Temperature (°C)	Power supplied (Vac)	Frequency error	
		Hz	ppm
25	102	63	0.025190
	120	77	0.030788
	138	42	0.016793
Reference Frequency: Lowest channel=2506.0MHz(20MHz for QPSK)			
Temperature (°C)	Power supplied (Vdc)	Frequency error	
		Hz	ppm
25	102	96	0.038308
	120	85	0.033919
	138	74	0.029529
Reference Frequency: Lowest channel=2501.0MHz(10MHz for 64QAM)			
Temperature (°C)	Power supplied (Vdc)	Frequency error	
		Hz	ppm
25	102	88	0.035186
	120	79	0.031587
	138	59	0.023591
Reference Frequency: Lowest channel=2506.0MHz(20MHz for 64QAM)			
Temperature (°C)	Power supplied (Vdc)	Frequency error	
		Hz	ppm
25	102	79	0.031524
	120	86	0.034318
	138	82	0.032721

**For IC test data (worst channel):**

Reference Frequency: Lowest channel=2575.0MHz(10MHz for QPSK)			
Temperature (°C)	Power supplied (Vac)	Frequency error	
		Hz	ppm
25	102	112	0.043495
	120	105	0.040777
	138	100	0.038835
Reference Frequency: Lowest channel=2580.0MHz(20MHz for QPSK)			
Temperature (°C)	Power supplied (Vdc)	Frequency error	
		Hz	ppm
25	102	112	0.043411
	120	102	0.039535
	138	98	0.037984
Reference Frequency: Lowest channel=2575.0MHz(10MHz for 64QAM)			
Temperature (°C)	Power supplied (Vdc)	Frequency error	
		Hz	ppm
25	102	108	0.041942
	120	116	0.045049
	138	112	0.043495
Reference Frequency: Lowest channel=2580.0MHz(20MHz for 64QAM)			
Temperature (°C)	Power supplied (Vdc)	Frequency error	
		Hz	ppm
25	102	108	0.041860
	120	96	0.037209
	138	103	0.039922