



Test report No:
NIE: 2477bRCB.001A3

Test report

Citizen Broadband Radio Service Test report

Identification of item tested	Citizens Band Category A and B Devices
Trademark	Baicells
Model and /or type reference	mBS31001
Other identification of the product	FCC ID: 2AG32MBS3100196N
Features	----
Manufacturer	Baicells Technologies Co., Ltd. 3F, Hui Yuan Development Building, No.1 Shangdi Information Industry Base, Haidian Dist., Beijing, PR China, 100085.
Final HW version	MBS31001 D
Final SW version	CBSD: BaiBS_QRTBA_0.3.1_rf_ready Domain Proxy: BaiOMC Rev-18822
Summary	USA FCC Part 96 CITIZENS BROADBAND RADIO SERVICE DEVICES OPERATIONG WITHIN THE BAND 3550-3700 MHz.
Approved by (name / position & signature)	Gonzalo Casado Lab Manager 
Date of issue	2020-Jun-19
Report template No	FDT08_22

Index

Competences and guarantees	3
General conditions	3
Uncertainty	4
Data provided by the client	4
Usage of samples	4
Identification of the client	4
Testing period and place.....	4
Document history	4
Modifications to the reference test report.....	5
Remarks and comments	5
Testing verdicts.....	5
Summary.....	5
Appendix A: Test Results.....	6
Appendix B: Test Systems.....	8
Test Setup.....	Error! Bookmark not defined.
Appendix C: DUT Photographs.....	9
Appendix D: CBSD/ DP Supported Features.....	11
Appendix E: Reference Standards and Procedures	12
Appendix F: Test Steps.....	14

Competences and guarantees

DEKRA Certification Inc. is a testing laboratory accredited by A2LA (The American Association for Laboratory Accreditation), to perform the tests indicated in the Certificate 2764.01.

DEKRA Certification, Inc. is a CBRS Alliance authorized test laboratory.

DEKRA Certification, Inc. is a WInnForum Approved CBSD test laboratory.

In order to assure the traceability to other national and international laboratories, DEKRA Certification, Inc. has a calibration and maintenance program for its measurement equipment.

DEKRA Certification, Inc. guarantees the reliability of the data presented in this report, which is the result of the measurements and the tests performed to the item under test on the date and under the conditions stated on the report and, it is based on the knowledge and technical facilities available at DEKRA Certification, Inc. at the time of performance of the test.

DEKRA Certification, Inc. is liable to the client for the maintenance of the confidentiality of all information related to the item under test and the results of the test.

The results presented in this Test Report apply only to the particular item under test established in this document.

IMPORTANT: No parts of this report may be reproduced or quoted out of context, in any form or by any means, except in full, without the previous written permission of DEKRA Certification, Inc.

General conditions

1. This report is only referred to the item that has undergone the test.
2. This report does not constitute or imply on its own an approval of the product by the Certification Bodies or competent Authorities.
3. This document is only valid if complete; no partial reproduction can be made without previous written permission of DEKRA Certification, Inc.
4. This test report cannot be used partially or in full for publicity and/or promotional purposes without previous written permission of DEKRA Certification, Inc and the Accreditation Bodies.

Uncertainty

Uncertainty (factor k=2) was calculated according to the DEKRA Certification, Inc internal document PODT000.

Data provided by the client

DEKRA declines any responsibility with respect to the information provided by the client and that may affect the validity of results.

Usage of samples

Samples undergoing test have been selected by: Baicells Technologies, Inc.

Sample M/01 is composed of the following elements:

Control N°	Description	Model	Serial N°	Hardware Version	Software Version	Date of reception
2477b.01	CBSD	NOVA436Q	191000004	mBS31001	BaiBS_QRTBA_0.3.1_rf_ready	4/9/2019
NA	Domain Proxy Software	BaiOMC	Not Applicable	BaiOMC	BaiOMC Rev-18822	Not Applicable

1. Sample M/01 has undergone the test(s) specified in subclause "Test method requested".

Identification of the client

Baicells Technologies Co., Ltd.

3F, Hui Yuan Development Building, No.1 Shangdi Information Industry Base, Haidian Dist., Beijing, PR China, 100085

Testing period and place

Test Location	DEKRA Certification, Inc.
Test Location Address	405 Glenn Dr #12, Sterling, VA 20164
Date (start)	2019-Apr-11
Date (finish)	2019-Apr-22

Document history

Report number	Date	Description
2477bRCB.001	2019-MAY-7	First release
2477bRCB.001A1	2019-MAY-20	Second release(Modifications performed are described in the subclause "Modifications to the reference test report")
2477bRCB.001A2	2019-Jul-23	Third release(Modifications performed are described in the subclause "Modifications to the reference test report")
2477bRCB.001A3	2020-Jun-19	Fourth release(Modifications performed are described in the subclause "Modifications to the reference test report")

Modifications to the reference test report

FCC id has been updated as per customer request:

Remarks and comments

1: The tests have been performed by the technical personnel: Indusha Chitepu

Testing verdicts

Not applicable :	N/A
Pass :	PASS
Fail :	FAIL
Not measured :	N/M

Summary

Standard :	WINNF-TS-0122
Band :	TDD 48
Total	PASS VERDICT
34	34

Appendix A: Test Results

Test Case ID	Test Case Name	Verdict	Date	Sample
WINNF.FT.D.REG.2	Domain Proxy Multi-Step registration	PASS	11-Apr-19	M/01
WINNF.FT.D.REG.6	Domain Proxy Single-Step registration for CBSD with CPI signed data	PASS	11-Apr-19	M/01
WINNF.FT.D.REG.9	Domain Proxy Missing Required parameters (responseCode 102)	PASS	11-Apr-19	M/01
WINNF.FT.D.REG.11	Domain Proxy Pending registration (responseCode 200)	PASS	11-Apr-19	M/01
WINNF.FT.D.REG.13	Domain Proxy Invalid parameters (responseCode 103)	PASS	11-Apr-19	M/01
WINNF.FT.D.REG.15	Domain Proxy Blacklisted CBSD (responseCode 101)	PASS	11-Apr-19	M/01
WINNF.FT.D.REG.17	Domain Proxy Unsupported SAS protocol version responseCode 100)	PASS	11-Apr-19	M/01
WINNF.FT.D.REG.19	Domain Proxy Group Error (responseCode 201)	PASS	11-Apr-19	M/01
WINNF.FT.C.GRA.1	Unsuccessful Grant responseCode=400 (INTERFERENCE)	PASS	11-Apr-19	M/01
WINNF.FT.C.GRA.2	Unsuccessful Grant responseCode=401 (GRANT CONFLICT)	PASS	11-Apr-19	M/01
WINNF.FT.D.HBT.2	Domain Proxy Heartbeat Success Case (first Heartbeat Response)	PASS	11-Apr-19	M/01
WINNF.FT.C.HBT.3	Heartbeat responseCode=105 (DEREGISTER)	PASS	11-Apr-19	M/01
WINNF.FT.C.HBT.5	Heartbeat responseCode=501 (SUSPENDED_GRANT) in First Heartbeat Response	PASS	11-Apr-19	M/01
WINNF.FT.C.HBT.6	Heartbeat responseCode=501 (SUSPENDED_GRANT) in Subsequent Heartbeat Response	PASS	11-Apr-19	M/01
WINNF.FT.C.HBT.7	Heartbeat responseCode=502 (UNSYNC OP PARAM)	PASS	11-Apr-19	M/01
WINNF.FT.D.HBT.8	Domain Proxy Heartbeat responseCode=500 (TEMINATED_GRANT)	PASS	11-Apr-19	M/01

Test Case ID	Test Case Name	Verdict	Date	Sample
WINNF.FT.C.HBT.9	Heartbeat Response Absent (First Heartbeat)	PASS	11-Apr-19	M/01
WINNF.FT.C.HBT.10	Heartbeat Response Absent (Subsequent Heartbeat)	PASS	11-Apr-19	M/01
WINNF.FT.C.HBT.11	Successful Grant Renewal in Heartbeat Test Case	PASS	11-Apr-19	M/01
WINNF.FT.D.MES.2	Domain Proxy Registration Response contains measReportConfig	PASS	11-Apr-19	M/01
WINNF.FT.C.MES.3	Grant Response contains measReportConfig	PASS	11-Apr-19	M/01
WINNF.FT.C.MES.5	Domain Proxy Heartbeat Response contains measReportConfig	PASS	11-Apr-19	M/01
WINNF.FT.D.RLQ.2	Domain Proxy Successful Relinquishment	PASS	11-Apr-19	M/01
WINNF.FT.D.RLQ.4	Domain Proxy Unsuccessful Relinquishment, responseCode=102	PASS	11-Apr-19	M/01
WINNF.FT.D.RLQ.6	Domain Proxy Unsuccessful Relinquishment, responseCode=103	PASS	11-Apr-19	M/01
WINNF.FT.D.DRG.2	Domain Proxy Successful Deregistration	PASS	11-Apr-19	M/01
WINNF.FT.D.DRG.4	Domain Proxy Deregistration responseCode=102	PASS	11-Apr-19	M/01
WINNF.FT.C.DRG.5	Deregistration responseCode=103	PASS	11-Apr-19	M/01
WINNF.FT.C.SCS.1	Successful TLS connection between UUT and SAS Test Harness	PASS	11-Apr-19	M/01
WINNF.FT.C.SCS.2	TLS failure due to revoked certificate	PASS	11-Apr-19	M/01
WINNF.FT.C.SCS.3	TLS failure due to expired server certificate	PASS	11-Apr-19	M/01
WINNF.FT.C.SCS.4	TLS failure when SAS Test Harness certificate is issue by unknown CA	PASS	11-Apr-19	M/01
WINNF.FT.C.SCS.5	TLS failure when certificate at the SAS Test Harness is corrupted	PASS	11-Apr-19	M/01
WINNF.PT.C.HBT	UUT RF Transmit Power Measurement	PASS	22-Apr-19	M/01

Appendix B: Test Systems

Description	Model	Control Number	SW Version
Test SAS harness	N/A	Laptop: CTC-5233-K	Test Harness:1.0.0.3 Laptop OS: Windows7
Signal Analyzer	MXA N9020A	2510.57	A.04.26

Test Setup Diagram

Domain Proxy Configuration

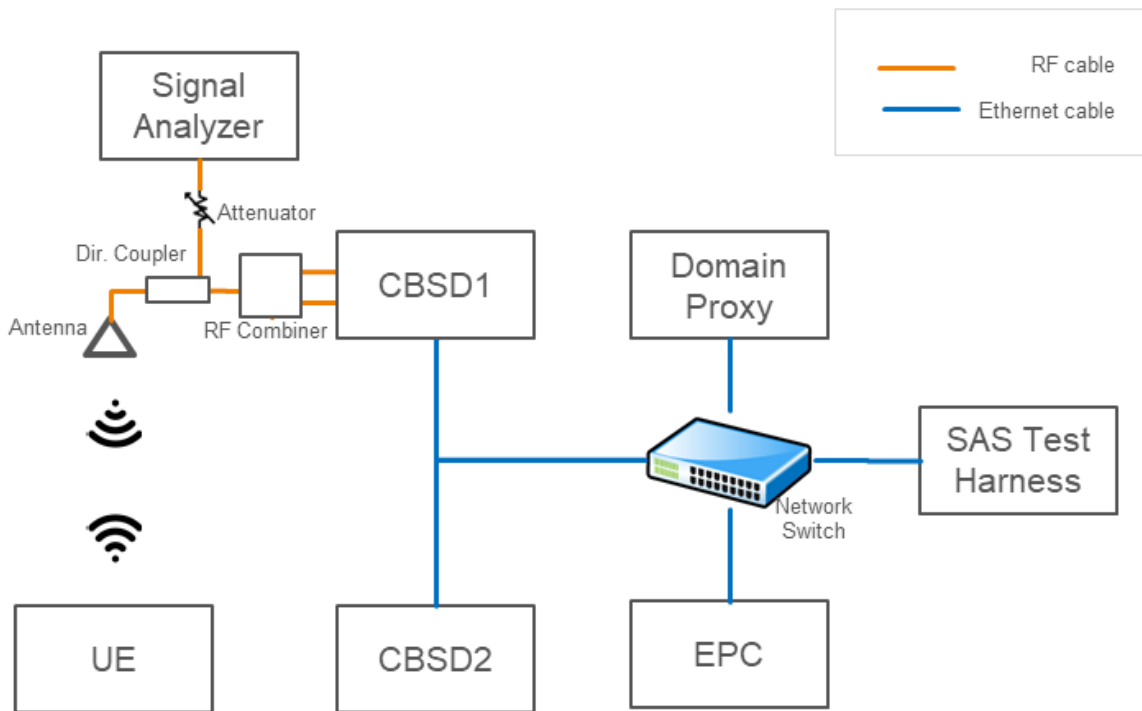

Appendix C: DUT Photographs





Appendix D: CBSD/ DP Supported Features

Condition	Feature Description	Supported
C1	Mandatory for UUT which supports multi-step registration message.	Y
C2	Mandatory for UUT which supports single-step registration with no CPI-signed data in the registration message. By definition, this is a subset of Category A devices which determine all registration information, including location, without CPI intervention.	N
C3	Mandatory for UUT which supports single-step registration containing CPI-signed data in the registration message.	Y
C4	Mandatory for UUT which supports RECEIVED_POWER_WITHOUT_GRANT measurement report type.	Y
C5	Mandatory for UUT which supports RECEIVED_POWER_WITH_GRANT measurement report type.	Y
C6	Mandatory for UUT which supports parameter change being made at the UUT and prior to sending a deregistration.	N

Appendix E: Reference Standards and Procedures

Reference Standards

Test and Certification for Citizens Broadband Radio Service (CBRS); Conformance and Performance Test Technical Specification; CBSD/DP as Unit Under Test (UUT) Working Document WINNF-TS-0122	V1.0.0
---	--------

Test Procedures

PECB001_00: CBRS Alliance Certification Testing Based On WINN Forum CBRS CBSD Test Specification "WINNF-TS-0122"
--

Test Requirements and Test Case Mapping

Requirement	Verified in TC
The device will only transmit after it receives authorization from a SAS	WINNF.FT.D.HBT.2
The device registration and authorization with the SAS – determine if the device behaves appropriately for successful and unsuccessful registrations. The device should not be transmitting without authorization from the SAS	WINNF.FT.D.REG.2 WINNF.FT.D.REG.9 WINNF.FT.D.REG.11 WINNF.FT.D.REG.13 WINNF.FT.D.REG.15 WINNF.FT.D.REG.17 WINNF.FT.D.REG.19
The device changes its operating power and/or channel in response to a command from the SAS	WINNF.PT.C.HBT
The device correctly configures based on the different license classes	WINNF.FT.C.SCS.1, WINNF.FT.C.SCS.2, WINNF.FT.C.SCS.3, WINNF.FT.C.SCS.4, WINNF.FT.C.SCS.5
The device transmits at a power level less than or equal to the maximum power level approved by the SAS	WINNF.PT.C.HBT
The device transmits with a bandwidth less than or equal to the SAS specified bandwidth.	WINNF.PT.C.HBT
The device transmits on the SAS specified frequency	WINNF.FT.D.HBT.2, WINNF.FT.C.HBT.3, WINNF.FT.C.HBT.4, WINNF.FT.C.HBT.5, WINNF.FT.C.HBT.6, WINNF.FT.C.HBT.7, WINNF.FT.D.HBT.8, WINNF.FT.C.HBT.9, WINNF.FT.C.HBT.10, WINNF.FT.C.HBT.11, WINNF.PT.C.HBT
The device stops transmission in response to a command from the SAS, within a period as required by Part 96	WINNF.FT.D.RLQ.2, WINNF.FT.D.RLQ.4, WINNF.FT.D.RLQ.6, WINNF.FT.D.DRG.2, WINNF.FT.D.DRG.4, WINNF.FT.C.DRG.5
the device sends measurements data in response to the command from the SAS.	WINNF.FT.C.MES.3, WINNF.FT.D.MES.5

Requirement	Verified in TC
For devices with geo-location, confirm that it notifies the SAS of a new location when it is beyond the required distance parameter (± 50 m) within the required time frame	N/A as Condition C2 is not supported by device
the device is capable of reporting the signal level (measurement data) and frequency to SAS	WINNF.FT.C.MES.3, WINNF.FT.D.MES.5
For a device that operates as a Category A CBSD and then desires to operate as a Category B CBSD (or vice versa), confirm that it re-registers with the SAS for the updated authorization status	N/A as DUT is not category A
Loss of communication with SAS behavior	WINNF.FT.C.HBT.9, WINNF.FT.C.HBT.10, WINNF.FT.D.RLQ.4, WINNF.FT.D.RLQ.6, WINNF.FT.D.DRG.4, WINNF.FT.C.DRG.5
Heartbeat loss behavior	WINNF.FT.C.HBT.10
When CBSDs communicate through a management system, confirm compliance with all requirements	The tested product has a Domain Proxy implementation; hence all relevant test cases mentioned in the above bullets are selected as such

Appendix F: Test Steps

Test Case ID	Description
WINNF.FT.D.REG.2	This test is mandatory for the Domain proxy that is controlling CBSDs which support multi-step registration. This test validates that each of the required parameters appear within the registration request message. This test case applies to Domain Proxy supervising two CBSDs
#	Test Execution Steps
1	Ensure the following conditions are met for test entry: •UUT has successfully completed SAS Discovery and Authentication with SAS Test Harness •UUT is in the Unregistered state
2	DP with two CBSD sends correct Registration request information, as specified in [n.5], in the form of one 2-element Array or as individual messages to the SAS Test Harness: •The required userId, fcld and cbsdSerialNumber registration parameters shall be sent for each CBSD and conform to proper format and acceptable ranges. •Any REG-conditional or optional registration parameters that may be included in the message shall be verified that they conform to proper format and are within acceptable ranges. Note: It is outside the scope of this document to test the Registration information that is supplied via another means.
3	•SAS Test Harness sends a CBSD Registration Response in the form of one 2-element Array or individual messages as follows: -cbsdId = Ci -measReportConfig shall not be included -responseCode = 0 for each CBSD
4	After completion of step 3, SAS Test Harness will not provide any positive response (responseCode=0) to further request messages from the UUT.
5	Monitor the RF output of each UUT from start of test until 60 seconds after Step 3 is complete. This is the end of the test. Verify: •UUT shall not transmit RF

Test Case ID	Description
WINNF.FT.C.REG.7	The purpose of this test is to verify the CBSD sends notification to the SAS when an installation parameter has been changed. This test is limited to CBSDs that support a registration parameter change/update to be made at the CBSD Further, this test only applies to CBSD devices that allow a registration parameter change to be made prior to sending a deregistration
#	Test Execution Steps
1	Ensure the following conditions are met for test entry: •UUT has successfully completed SAS Discovery and Authentication with SAS Test Harness
2	UUT has successfully registered with SAS Test Harness
3	Change an installation parameters at the UUT (time T) Tester needs to record the current time at which the parameter change is executed.
4	Monitor the SAS-CBSD interface. UUT sends a deregistrationRequest to the SAS Test Harness The deregistration request shall be sent within (T + 60 seconds) from step 3.

Test Case ID	Description
WINNF.FT.D.REG.9	This test case applies to Domain Proxy supervising two CBSDs. The following are the test execution steps where the Registration response contains responseCode (Ri) = 102 (Domain Proxy Missing Required parameters) for each CBSD
#	Test Execution Steps
1	Ensure the following conditions are met for test entry: •UUT has successfully completed SAS Discovery and Authentication with SAS Test Harness •UUT is in the Unregistered state
2	The DP with two CBSDs sends a Registration request in the form of one 2-element Array or as individual messages to SAS Test Harness.
3	SAS Test Harness sends a CBSD Registration Response in the form of one 2-element Array or as individual messages as follows: -SAS response does not include a cbsdId. -responseCode = Ri for CBSD1 and CBSD2
4	After completion of step 3, SAS Test Harness will not provide any positive response (responseCode=0) to further request messages from the UUT.
5	Monitor the RF output of each UUT from start of test until 60 seconds after Step 3 is complete. This is the end of the test. Verify: •• UUT shall not transmit RF

Test Case ID	Description
WINNF.FT.D.REG.11	This test case applies to Domain Proxy supervising two CBSDs. The following are the test execution steps where the Registration response contains responseCode (Ri) = 200 (Domain Proxy Pending registration) for each CBSD
#	Test Execution Steps
1	Ensure the following conditions are met for test entry: •UUT has successfully completed SAS Discovery and Authentication with SAS Test Harness •UUT is in the Unregistered state
2	The DP with two CBSDs sends a Registration request in the form of one 2-element Array or as individual messages to SAS Test Harness.
3	SAS Test Harness sends a CBSD Registration Response in the form of one 2-element Array or as individual messages as follows: -SAS response does not include a cbsdId. -responseCode = Ri for CBSD1 and CBSD2
4	After completion of step 3, SAS Test Harness will not provide any positive response (responseCode=0) to further request messages from the UUT.
5	Monitor the RF output of each UUT from start of test until 60 seconds after Step 3 is complete. This is the end of the test. Verify: •• UUT shall not transmit RF

Test Case ID	Description
WINNF.FT.D.REG.13	This test case applies to Domain Proxy supervising two CBSDs. The following are the test execution steps where the Registration response contains responseCode R1 = 0 for CBSD1 and R2 = 103 (Invalid parameter) for CBSD2
#	Test Execution Steps
1	Ensure the following conditions are met for test entry: •UUT has successfully completed SAS Discovery and Authentication with SAS Test Harness •UUT is in the Unregistered state
2	The DP with two CBSDs sends a Registration request in the form of one 2-element Array or as individual messages to SAS Test Harness.
3	SAS Test Harness sends a CBSD Registration Response in the form of one 2-element Array or as individual messages as follows: -SAS response does not include a cbsdId. -responseCode = Ri for CBSD1 and CBSD2
4	After completion of step 3, SAS Test Harness will not provide any positive response (responseCode=0) to further request messages from the UUT.
5	Monitor the RF output of each UUT from start of test until 60 seconds after Step 3 is complete. This is the end of the test. Verify: •• UUT shall not transmit RF

Test Case ID	Description
WINNF.FT.D.REG.15	This test case applies to Domain Proxy supervising two CBSDs. The following are the test execution steps where the Registration response contains responseCode R1 = 0 for CBSD1 and R2 = 101 (Domain Proxy Blacklisted CBSD) for CBSD2
#	Test Execution Steps
1	Ensure the following conditions are met for test entry: •UUT has successfully completed SAS Discovery and Authentication with SAS Test Harness •UUT is in the Unregistered state
2	The DP with two CBSDs sends a Registration request in the form of one 2-element Array or as individual messages to SAS Test Harness.
3	SAS Test Harness sends a CBSD Registration Response in the form of one 2-element Array or as individual messages as follows: -SAS response does not include a cbsdId. - responseCode = Ri for CBSD1 and CBSD2
4	After completion of step 3, SAS Test Harness will not provide any positive response (responseCode=0) to further request messages from the UUT.
5	Monitor the RF output of each UUT from start of test until 60 seconds after Step 3 is complete. This is the end of the test. Verify: •• UUT shall not transmit RF

Test Case ID	Description
WINNF.FT.D.REG.17	This test case applies to Domain Proxy supervising two CBSDs. The following are the test execution steps where the Registration response contains responseCode (Ri) = 100 (Domain Proxy Unsupported SAS protocol version) for each CBSD
#	Test Execution Steps
1	Ensure the following conditions are met for test entry: •UUT has successfully completed SAS Discovery and Authentication with SAS Test Harness •UUT is in the Unregistered state
2	The DP with two CBSDs sends a Registration request in the form of one 2-element Array or as individual messages to SAS Test Harness.
3	SAS Test Harness sends a CBSD Registration Response in the form of one 2-element Array or as individual messages as follows: -SAS response does not include a cbsdId. - responseCode = Ri for CBSD1 and CBSD2
4	After completion of step 3, SAS Test Harness will not provide any positive response (responseCode=0) to further request messages from the UUT.
5	Monitor the RF output of each UUT from start of test until 60 seconds after Step 3 is complete. This is the end of the test. Verify: •• UUT shall not transmit RF

Test Case ID	Description
WINNF.FT.D.REG.19	This test case applies to Domain Proxy supervising two CBSDs. The following are the test execution steps where the Registration response contains responseCode R1 = 0 for CBSD1 and R2 = 201 (Domain Proxy Group Error) for CBSD2
#	Test Execution Steps
1	Ensure the following conditions are met for test entry: •UUT has successfully completed SAS Discovery and Authentication with SAS Test Harness •UUT is in the Unregistered state
2	The DP with two CBSDs sends a Registration request in the form of one 2-element Array or as individual messages to SAS Test Harness.
3	SAS Test Harness sends a CBSD Registration Response in the form of one 2-element Array or as individual messages as follows: -SAS response does not include a cbsdId. - responseCode = Ri for CBSD1 and CBSD2
4	After completion of step 3, SAS Test Harness will not provide any positive response (responseCode=0) to further request messages from the UUT.
5	Monitor the RF output of each UUT from start of test until 60 seconds after Step 3 is complete. This is the end of the test. Verify: •• UUT shall not transmit RF

Test Case ID	Description
WINNF.FT.C.GRA.1	The following steps describe the test execution where the Grant response contains responseCode (R) = 400 (INTERFERENCE)
#	Test Execution Steps
1	Ensure the following conditions are met for test entry: •UUT has registered successfully with SAS Test Harness, with cbsdId = C
2	UUT sends valid Grant Request.
3	SAS Test Harness sends a Grant Response message, including •cbsdId=C •responseCode = R
4	After completion of step 3, SAS Test Harness will not provide any positive response (responseCode=0) to further request messages from the UUT.
5	Monitor the RF output of the UUT from start of test until 60 seconds after Step 3 is complete. This is the end of the test. Verify: •UUT shall not transmit RF

Test Case ID	Description
WINNF.FT.C.GRA.2	The following steps describe the test execution where the Grant response contains responseCode (R) = 401 (GRANT CONFLICT)
#	Test Execution Steps
1	Ensure the following conditions are met for test entry: •UUT has registered successfully with SAS Test Harness, with cbsdId = C
2	UUT sends valid Grant Request.
3	SAS Test Harness sends a Grant Response message, including •cbsdId=C •responseCode = R
4	After completion of step 3, SAS Test Harness will not provide any positive response (responseCode=0) to further request messages from the UUT.
5	Monitor the RF output of the UUT from start of test until 60 seconds after Step 3 is complete. This is the end of the test. Verify: •UUT shall not transmit RF

Test Case ID	Description
WINNF.FT.D.HBT.2	This test case incorporates validation of successful Spectrum Inquiry messaging (if present) and successful Grant messaging into the Heartbeat Success case. This test case applies to Domain Proxy supervising two CBSDs.
#	Test Execution Steps
1	Ensure the following conditions are met for test entry: •DP has two CBSD registered successfully with SAS Test Harness, with cbsdId = Ci, i={1,2}
2	DP sends a message: •If message is a Spectrum Inquiry Request, go to step 3 •If message is a Grant Request, go to step 5
3	DP sends a Spectrum Inquiry Request message for each CBSD. This may occur in a separate message per CBSD, or together in a single message with array of 2. Verify Spectrum Inquiry Request message is formatted correctly for each CBSD, including for CBSDi, i={1,2}: •cbsdId = Ci •List of frequencyRange objects sent by DP are within the CBRS frequency range
4	If a separate Spectrum Inquiry Request message was sent for each CBSD, the SAS Test Harness shall respond to each Spectrum Inquiry Request message with a separate Spectrum Inquiry Response message. If a single Spectrum Inquiry Request message was sent containing a 2object array (one per CBSD), the SAS Test Harness shall respond with a single Spectrum Inquiry Response message containing a 2-object array. Verify parameters for each CBSD within the Spectrum Inquiry Response message are as follows, for CBSDi, i={1,2}: •cbsdId = Ci •availableChannel is an array of availableChannel objects •responseCode = 0
5	DP sends a Grant Request message for each CBSD. This may occur in a separate message per CBSD, or together in a single message with array of 2. Verify Grant Request message is formatted correctly for each CBSD, including for CBSDi, i={1,2}: •cbsdId = C •maxEIRP is at or below the limit appropriate for CBSD category as defined by Part 96 •operationFrequencyRange, Fi, sent by UUT is a valid range within the CBRS band

Test Case ID	Description
WINNF.FT.D.HBT.2	This test case incorporates validation of successful Spectrum Inquiry messaging (if present) and successful Grant messaging into the Heartbeat Success case. This test case applies to Domain Proxy supervising two CBSDs.
#	Test Execution Steps
6	<p>If a separate Grant Request message was sent for each CBSD, the SAS Test Harness shall respond to each Grant Request message with a separate Grant Response message. If a single Grant Request message was sent containing a 2-object array (one per CBSD), the SAS Test Harness shall respond with a single Grant Response message containing a 2-object array. Verify parameters for each CBSD within the Grant Response message are as follows, for CBSDi, i={1,2}: •cbsdId = Ci •grantId = Gi = a valid grant ID •grantExpireTime = UTC time greater than duration of the test •responseCode = 0</p>
7	<p>Ensure DP sends first Heartbeat Request message for each CBSD. This may occur in a separate message per CBSD, or together in a single message with array of 2. Verify Heartbeat Request message is formatted correctly for each CBSD, including, for CBSDi i={1,2}: •cbsdId = Ci, i={1,2} •grantId = Gi, i={1,2} •operationState = "GRANTED"</p> <p>If a separate Heartbeat Request message was sent for each CBSD by the DP, the SAS Test Harness shall respond to each Heartbeat Request message with a separate Heartbeat Response message.</p>
8	<p>If a single Heartbeat Request message was sent by the DP containing a 2-object array (one per CBSD), the SAS Test Harness shall respond with a single Heartbeat Response message containing a 2-object array. Verify parameters for each CBSD within the Heartbeat Response message are as follows, for CBSDi: •cbsdId = Ci •grantId = Gi •transmitExpireTime = current UTC time + 200 seconds •responseCode = 0</p>
9	<p>For further Heartbeat Request messages sent from DP after completion of step 8, validate message is sent within latest specified heartbeatInterval for CBSDi: •cbsdId = Ci •grantId = Gi •operationState = "AUTHORIZED" and SAS Test Harness responds with a Heartbeat Response message including the following parameters, for CBSDi •cbsdId = Ci •grantId = Gi •transmitExpireTime = current UTC time + 200 seconds •responseCode = 0</p>
10	<p>Monitor the RF output of the UUT from start of test until UUT transmission commences. Monitor the RF output of the UUT from start of test until RF transmission commences. Verify: •UUT does not transmit at any time prior to completion of the first heartbeat response •UUT transmits after step 8 is complete, and its transmission is limited to within the bandwidth range Fi.</p>

Test Case ID	Description
WINNF.FT.C.HBT.3	Heartbeat responseCode=105 (DEREGISTER)
#	Test Execution Steps
1	Ensure the following conditions are met for test entry: •UUT has registered successfully with SAS Test Harness •UUT has a valid single grant as follows: ovalid cbsdId = C ovalid grantId = G ogrant is for frequency range F, power P ograntExpireTime = UTC time greater than duration of the test •UUT is in AUTHORIZED state and is transmitting within the grant bandwidth F on RF interface
2	UUT sends a Heartbeat Request message. Ensure Heartbeat Request message is sent within Heartbeat Interval specified in the latest Heartbeat Response, and formatted correctly, including: •cbsdId = C •grantId = G •operationState = "AUTHORIZED"
3	SAS Test Harness sends a Heartbeat Response message, including the following parameters: •cbsdId = C •grantId = G •transmitExpireTime = T = Current UTC time •responseCode = 105 (DEREGISTER)
4	After completion of step 3, SAS Test Harness shall not allow any further grants to the UUT.
5	Monitor the RF output of the UUT. Verify: •UUT shall stop transmission within (T + 60 seconds) of completion of step 3

Test Case ID	Description
WINNF.FT.C.HBT.4	Heartbeat responseCode=500 (TERMINATED_GRANT)
#	Test Execution Steps
1	Ensure the following conditions are met for test entry: •UUT has registered successfully with SAS Test Harness •UUT has a valid single grant as follows: ovalid cbsdId = C ovalid grantId = G ogrant is for frequency range F, power P ograntExpireTime = UTC time greater than duration of the test •UUT is in AUTHORIZED state and is transmitting within the grant bandwidth F on RF interface
2	UUT sends a Heartbeat Request message. Ensure Heartbeat Request message is sent within latest specified heartbeatInterval, and is formatted correctly, including: •cbsdId = C •grantId = G •operationState = "AUTHORIZED"
3	SAS Test Harness sends a Heartbeat Response message, including the following parameters: •cbsdId = C •grantId = G •transmitExpireTime = T = current UTC time •responseCode = 500 (TERMINATED_GRANT)
4	After completion of step 3, SAS Test Harness shall not allow any further grants to the UUT.
5	Monitor the RF output of the UUT. Verify: •UUT shall stop transmission within (T + 60 seconds) of completion of step 3

Test Case ID	Description
WINNF.FT.C.HBT.5	Heartbeat responseCode=501 (SUSPENDED_GRANT) in First Heartbeat Response
#	Test Execution Steps
1	Ensure the following conditions are met for test entry: •UUT has registered successfully with SAS Test Harness •UUT has a valid single grant as follows: ovalid cbsdId = C ovalid grantId = G ogrant is for frequency range F, power P ograntExpireTime = UTC time greater than duration of the test •UUT is in GRANTED, but not AUTHORIZED state (i.e. has not performed its first Heartbeat Request)
2	UUT sends a Heartbeat Request message. Verify Heartbeat Request message is formatted correctly, including: •cbsdId = C •grantId = G •operationState = "GRANTED"
3	SAS Test Harness sends a Heartbeat Response message, including the following parameters: •cbsdId = C •grantId = G •transmitExpireTime = T = current UTC time •responseCode = 501 (SUSPENDED_GRANT)
4	After completion of step 3, SAS Test Harness shall not allow any further grants to the UUT.
5	Monitor the SAS-CBSD interface. Verify either A OR B occurs: A. UUT sends a Heartbeat Request message. Ensure message is sent within latest specified heartbeatInterval, and is correctly formatted with parameters: •cbsdId = C •grantId = G •operationState = "GRANTED" B. UUT sends a Relinquishment request message. Ensure message is correctly formatted with parameters: •cbsdId = C •grantId = G Monitor the RF output of the UUT. Verify: •UUT does not transmit at any time

Test Case ID	Description
WINNF.FT.C.HBT.6	responseCode=501 (SUSPENDED_GRANT) in Subsequent Heartbeat Response
#	Test Execution Steps
1	Ensure the following conditions are met for test entry: •UUT has registered successfully with SAS Test Harness •UUT has a valid single grant as follows: ovalid cbsdId = C ovalid grantId = G ogrant is for frequency range F, power P ograntExpireTime = UTC time greater than duration of the test •UUT is in AUTHORIZED state and is transmitting within the grant bandwidth F on RF interface
2	UUT sends a Heartbeat Request message. Verify Heartbeat Request message is sent within latest specified heartbeatInterval, and is formatted correctly, including: •cbsdId = C •grantId = G •operationState = "AUTHORIZED"
3	SAS Test Harness sends a Heartbeat Response message, including the following parameters: •cbsdId = C •grantId = G •transmitExpireTime = T = current UTC time •responseCode = 501 (SUSPENDED_GRANT)
4	After completion of step 3, SAS Test Harness shall not allow any further grants to the UUT.
5	Monitor the SAS-CBSD interface. Verify either A OR B occurs: A. UUT sends a Heartbeat Request message. Ensure message is sent within latest specified heartbeatInterval, and is correctly formatted with parameters: •cbsdId = C •grantId = G •operationState = "GRANTED" B. UUT sends a Relinquishment Request message. Ensure message is correctly formatted with parameters: •cbsdId = C •grantId = G Monitor the RF output of the UUT. Verify: • UUT shall stop transmission within (T + 60 seconds) of completion of step 3

Test Case ID	Description
WINNF.FT.C.HBT.7	Heartbeat responseCode=502 (UNSYNC_OP_PARAM)
#	Test Execution Steps
1	Ensure the following conditions are met for test entry: •UUT has registered successfully with SAS Test Harness •UUT has a valid single grant as follows: ovalid cbsdId = C ovalid grantId = G ogrant is for frequency range F, power P ograntExpireTime = UTC time greater than duration of the test •UUT is in AUTHORIZED state and is transmitting within the grant bandwidth F on RF interface
2	UUT sends a Heartbeat Request message. Verify Heartbeat Request message is sent within latest specified heartbeatInterval, and is formatted correctly, including: •cbsdId = C •grantId = G •operationState = "AUTHORIZED"
3	SAS Test Harness sends a Heartbeat Response message, including the following parameters: •cbsdId = C •grantId = G •transmitExpireTime = T = Current UTC Time •responseCode = 502 (UNSYNC_OP_PARAM)
4	After completion of step 3, SAS Test Harness shall not allow any further grants to the UUT.
5	Monitor the SAS-CBSD interface. Verify: •UUT sends a Grant Relinquishment Request message. Verify message is correctly formatted with parameters: ocbsdId = C ograntId = G Monitor the RF output of the UUT. Verify: •UUT shall stop transmission within (T+60) seconds of completion of step 3.

Test Case ID	Description
WINNF.FT.D.HBT.8	Domain Proxy Heartbeat responseCode=500 (TERMINATED_GRANT)
#	Test Execution Steps
1	Ensure the following conditions are met for test entry: <ul style="list-style-type: none"> •DP has two CBSD registered successfully with SAS Test Harness •Each CBSD {1,2} has a valid single grant as follows: ovalid cbsdId = Ci, i={1,2} ovalid grantId = Gi, i={1,2} ogrant is for frequency range Fi, power Pi ograntExpireTime = UTC time greater than duration of the test •Both CBSD are in AUTHORIZED state and transmitting within their granted bandwidth on RF interface
2	DP sends a Heartbeat Request message for each CBSD. This may occur in a separate message per CBSD, or together in a single message with array of size 2. Verify Heartbeat Request message is sent within latest specified heartbeatInterval, and is formatted correctly for each CBSD, including, for CBSDi i={1,2}: <ul style="list-style-type: none"> •cbsdId = Ci, i = {1,2} •grantId = Gi, i = {1,2} •operationState = "AUTHORIZED" If separate Heartbeat Request message was sent for each CBSD by the DP, the SAS Test Harness shall respond to each Heartbeat Request message with a separate Heartbeat Response message. If a single Heartbeat Request message was sent by the DP containing a 2-object array (one per CBSD), the SAS Test Harness shall respond with a single Heartbeat Response message containing a 2-object array.
3	Parameters for each CBSD within the Heartbeat Response message should be as follows, for CBSDi: <ul style="list-style-type: none"> •cbsdId = Ci •grantId = Gi •For CBSD1: transmitExpireTime = current UTC time + 200 seconds responseCode = 0 •For CBSD2: transmitExpireTime = T = current UTC time responseCode = 500 (TERMINATED_GRANT) After completion of step 3, SAS Test Harness shall not allow any further grants to the UUT.
4	If CBSD sends further Heartbeat Request messages for CBSD1, SAS Test Harness shall respond with a Heartbeat Response message with parameters: <ul style="list-style-type: none"> •cbsdId = C1 •grantId = G1 •transmitExpireTime = current UTC time + 200 seconds •responseCode = 0 Heartbeat Request message is within heartbeatInterval of previous Heartbeat Request message Monitor the RF output of CBSD2. Verify: <ul style="list-style-type: none"> •CBSD2 shall stop transmission within bandwidth F2 within (T + 60 seconds) of completion of step 3

Test Case ID	Description
WINNF.FT.C.HBT.9	Heartbeat Response Absent (First Heartbeat)
#	Test Execution Steps
1	Ensure the following conditions are met for test entry: <ul style="list-style-type: none"> •UUT has registered successfully with SAS Test Harness •UUT has a valid single grant as follows: ovalid cbsdId = C ovalid grantId = G ogrant is for frequency range F, power P ograntExpireTime = UTC time greater than duration of the test •UUT is in GRANTED, but not AUTHORIZED state (i.e. has not performed its first Heartbeat Request)
2	UUT sends a Heartbeat Request message. Ensure Heartbeat Request message is sent within latest specified heartbeatInterval, and is formatted correctly, including: <ul style="list-style-type: none"> •cbsdId = C •grantId = G •operationState = "GRANTED"
3	After completion of Step 2, SAS Test Harness does not respond to any further messages from UUT to simulate loss of network connection
4	Monitor the RF output of the UUT from start of test to 60 seconds after step 3. Verify: <ul style="list-style-type: none"> •At any time during the test, UUT shall not transmit on RF interface

Test Case ID	Description
WINNF.FT.C.HBT.10	Heartbeat Response Absent (Subsequent Heartbeat)
#	Test Execution Steps
1	Ensure the following conditions are met for test entry: •UUT has registered successfully with SAS Test Harness •UUT has a valid single grant as follows: ovalid cbsdId = C ovalid grantId = G ogrant is for frequency range F, power P ograntExpireTime = UTC time greater than duration of the test •UUT is in AUTHORIZED state and is transmitting within the grant bandwidth F on RF interface
2	UUT sends a Heartbeat Request message. Verify Heartbeat Request message is sent within the latest specified heartbeatInterval, and is formatted correctly, including: •cbsdId = C •grantId = G •operationState = "AUTHORIZED"
3	SAS Test Harness sends a Heartbeat Response message, with the following parameters: •cbsdId = C •grantId = G •transmitExpireTime = current UTC time + 200 seconds •responseCode = 0
4	After completion of Step 3, SAS Test Harness does not respond to any further messages from UUT
5	Monitor the RF output of the UUT. Verify: •UUT shall stop all transmission on RF interface within (transmitExpireTime + 60 seconds), using the transmitExpireTime sent in Step 3.

Test Case ID	Description
WINNF.FT.C.HBT.11	Successful Grant Renewal in Heartbeat Test Case
#	Test Execution Steps
1	Ensure the following conditions are met for test entry: •UUT has registered successfully with SAS Test Harness •UUT has a valid single grant as follows: ovalid cbsdId = C ovalid grantId = G ogrant is for frequency range F, power P •UUT is in AUTHORIZED state and is transmitting within the grant bandwidth F on RF interface. •Grant has the following parameters at the start of the test: ograntExpireTime =UTC time equal to time at start of test + 300 seconds = Tgrant_expire otransmitExpireTime = UTC time equal to time at start of test + 200 seconds oheartbeatInterval = 60 seconds
2	UUT sends a Heartbeat Request message. If Heartbeat Request message contains grantRenew = TRUE, go to Step 6, else go to Step 3.
3	Verify Heartbeat Request message is sent within the latest specified heartbeatInterval, and is formatted correctly, including: •cbsdId = C •grantId = G •operationState = "AUTHORIZED"
4	SAS Test Harness sends a Heartbeat Response message, with the following parameters: •cbsdId = C •grantId = G •transmitExpireTime = current UTC + 200 seconds •grantExpireTime = same as Step 1 •responseCode = 0
5	Go to Step 2
6	Verify Heartbeat Request message is sent within the latest specified heartbeatInterval, and is formatted correctly, including: •cbsdId = C •grantId = G •operationState = "AUTHORIZED" •grantRenew = TRUE
7	SAS Test Harness sends a Heartbeat Response message, with the following parameters: •cbsdId = C •grantId = G •grantExpireTime = UTC time set far in the future •transmitExpireTime = current UTC time + 200 seconds •responseCode = 0
8	Continue to respond to any subsequentHeartbeat Request from CBSD with Heartbeat Response with the following parameters: •cbsdId = C •grantId = G •transmitExpireTime = same as Step 7 •responseCode = 0
9	Monitor RF transmission of UUT from start of test until Tgrant_expire + 60 seconds and ensure UUT continues to transmit throughout the time period.

Test Case ID	Description
WINNF.FT.C.MES.3	Grant Response contains measReportConfig This test case is mandatory for UUT supporting RECEIVED_POWER_WITH_GRANT measurement reports.
#	Test Execution Steps
1	Ensure the following conditions are met for test entry: •UUT has successfully completed SAS Discovery and Authentication with SAS Test Harness •UUT has successfully registered with SAS Test Harness, with cbsdId=C and measCapability = "RECEIVED_POWER_WITH_GRANT"
2	UUT sends a Grant Request message. Verify Grant Request message contains all required parameters properly formatted, and specifically: •cbsdId = C •operationParam is present and format is valid
3	SAS Test Harness sends a Grant Response message, with the following parameters: •cbsdId = C •grantId = G = valid grant ID •grantExpireTime = UTC time in the future •heartbeatInterval = 60 seconds •measReportConfig= "RECEIVED_POWER_WITH_GRANT" •operationParam is set to valid operating parameters •channelType = "GAA" •responseCode = 0
4	UUT sends a Heartbeat Request message. Verify message contains all required parameters properly formatted, and specifically: •cbsdId = C •grantId = G •operationState = "GRANTED"
5	If Heartbeat Request message (step 4) contains measReport object, then: •verify measReport is properly formatted as object rcvdPowerMeasReport •end test, with PASS result else, if Heartbeat Request message (step 4) does not contain measReport object, then: If number of Heartbeat Requests sent by UUT after Step 3 is = 5, then stop test with result of FAIL
6	SAS Test Harness sends a Heartbeat Response message, containing all required parameters properly formatted, and specifically: •cbsdId = C •grantId = G •transmitExpireTime = current UTC time + 200 seconds •responseCode = 0 Go to Step 4, above

Test Case ID	Description
WINNF.FT.D.MES.5	Domain Proxy Heartbeat Response contains measReportConfig This test case is mandatory for Domain Proxy supervising CBSD which support RECEIVED_POWER_WITH_GRANT measurement reports.
#	Test Execution Steps
1	Ensure the following conditions are met for test entry: •DP has successfully completed SAS Discovery and Authentication with SAS Test Harness •DP has successfully registered 2 CBSD with SAS Test Harness, each with cbsdId=Ci, i={1,2} and measCapability = "RECEIVED_POWER_WITH_GRANT" •DP has received a valid grant with grantId = Gi, i={1,2} for each CBSD •Both CBSD are in Grant State AUTHORIZED and actively transmitting within the bounds of their grants. •Grants have heartbeatInterval =60 seconds
2	Verify DP sends a Heartbeat Request message for each CBSD. This may occur in a separate message per CBSD, or together in a single message with array of 2. Verify Heartbeat Request message contains all required parameters properly formatted for each CBSD, specifically, for CBSDi: •cbsdId = Ci •grantId = Gi •operationState = "AUTHORIZED" If a separate Heartbeat Request message was sent for each CBSD by the DP, the SAS Test Harness shall respond to each Heartbeat Request message with a separate Heartbeat Response message.
3	If a single Heartbeat Request message was sent by the DP containing a 2-object array (one per CBSD), the SAS Test Harness shall respond with a single Heartbeat Response message containing a 2-object array. Parameters for each CBSD within the Heartbeat Response message containing all required parameters properly formatted, and specifically: •cbsdId = Ci •grantId = Gi •measReportConfig= "RECEIVED_POWER_WITH_GRANT" •responseCode = 0
4	Verify DP sends a Heartbeat Request message for each CBSD. This may occur in a separate message per CBSD, or together in a single message with array of 2. Verify Heartbeat Request message contains all required parameters properly formatted for each CBSD, and specifically, for CBSDi, i = {1,2}: •cbsdId = Ci •grantId = Gi •operationState = "AUTHORIZED" •Check whether measReport is present, and if present, ensure it is a properly formatted rcvdPowerMeasReport object, and record its reception for each CBSDi, i = {1,2}.
5	If Heartbeat Request message (step 4) contains measReport object, then: •Verify measReport is properly formatted as object rcvdPowerMeasReport •record which CBSD have successfully sent a measReport object If all CBSDi, i = {1,2} have successfully sent a measReport object, then •end test, with PASS result else, if the number of Heartbeat Requests sent per CBSD is 5 or more, then stop test with result of FAIL If a separate Heartbeat Request message was sent for each CBSD by the DP, the SAS Test Harness shall respond to each Heartbeat Request message with a separate Heartbeat Response message.
6	If a single Heartbeat Request message was sent by the DP containing a 2-object array (one per CBSD), the SAS Test Harness shall respond with a single Heartbeat Response message containing a 2-object array. Parameters for each CBSD within the Heartbeat Response message containing all required parameters properly formatted, and specifically: •cbsdId = Ci •grantId = Gi •responseCode = 0 Go to Step 4, above.

Test Case ID	Description
WINNF.FT.D.RLQ.2	Domain Proxy Successful Relinquishment
#	Test Execution Steps
1	Ensure the following conditions are met for test entry: •DP has successfully completed SAS Discovery and Authentication with SAS Test Harness •DP has successfully registered 2 CBSD with SAS Test Harness, each with cbsdId=Ci, i={1,2} •DP has received a valid grant with grantId = Gi, i={1,2} for each CBSD •Both CBSD are in Grant State AUTHORIZED and actively transmitting within the bounds of their grants. Invoke trigger to relinquish each UUT Grant from the SAS Test Harness
2	Verify DP sends a Relinquishment Request message for each CBSD. This may occur in a separate message per CBSD, or together in a single message with array of 2. Verify Relinquishment Request message contains all required parameters properly formatted for each CBSD, specifically, for CBSDi: •cbsdId = Ci •grantId = Gi
3	If a separate Relinquishment Request message was sent for each CBSD by the DP, the SAS Test Harness shall respond to each request message with a separate response message. If a single Relinquishment Request message was sent by the DP containing a 2-object array (one per CBSD), the SAS Test Harness shall respond with a single Response message containing a 2-object array. Parameters for each CBSD within the Relinquishment Response shall be as follows: •cbsdId = Ci •grantId = Gi •responseCode = 0
4	After completion of step 3, SAS Test Harness will not provide any additional positive response (responseCode=0) to further request messages from the UUT.
5	Monitor the RF output of each UUT from start of test until 60 seconds after Step 3 is complete. This is the end of the test. Verify: •UUT shall stop RF transmission at any time between triggering the relinquishments and UUT sending the relinquishment requests for each CBSD.

Test Case ID	Description
WINNF.FT.D.RLQ.4	Domain Proxy Unsuccessful Relinquishment, responseCode=102 This test case applies to Domain Proxy supervising two CBSDs. The following are the test execution steps where the Relinquishment response contains responseCode (Ri) = 102 for each CBSD
#	Test Execution Steps
1	Ensure the following conditions are met for test entry: <ul style="list-style-type: none"> •DP has successfully completed SAS Discovery and Authentication with SAS Test Harness •DP has successfully registered 2 CBSD with SAS Test Harness, each with cbsdId=Ci, i={1,2} •DP has received a valid grant with grantId = Gi, i={1,2} for each CBSD •Both CBSD are in Grant State AUTHORIZED and actively transmitting within the bounds of their grants. Invoke trigger on UUT to Relinquish Grant from the SAS Test Harness
2	DP with two CBSDs sends Relinquishment Request with two objects to the SAS Test Harness. This may occur in a separate message per CBSD, or together in a single message with array of 2. Verify DP sends a Relinquishment Request message for each CBSD. This may occur in a separate message per CBSD, or together in a single message with array of 2. Verify Relinquishment Request message contains all required parameters properly formatted for each CBSD, specifically, for CBSDi: <ul style="list-style-type: none"> •cbsdId = Ci •grantId = Gi
3	If a separate Relinquishment Request message was sent for each CBSD by the DP, the SAS Test Harness shall respond to each request message with a separate response message. If a single Relinquishment Request message was sent by the DP containing a 2-object array (one per CBSD), the SAS Test Harness shall respond with a single Response message containing a 2-object array. Parameters for each CBSD within the Relinquishment Response Message shall be as follows: <ul style="list-style-type: none"> •cbsdId = Ci •No grantId •responseCode = Ri
4	After completion of step 3, SAS Test Harness will not provide any positive response (responseCode=0) to further request messages from the UUT.
5	Monitor the RF output of each UUT from start of test until 60 seconds after Step 3 is complete. This is the end of the test. Verify: <ul style="list-style-type: none"> A. UUT stopped RF transmission at any time between triggering the relinquishment and UUT sending the relinquishment request

Test Case ID	Description
WINNF.FT.D.RLQ.6	Domain Proxy Unsuccessful Relinquishment, responseCode=103 This test case applies to Domain Proxy supervising two CBSDs. The following are the test execution steps where the Relinquishment response contains responseCode (Ri) = 103 for each CBSD.
#	Test Execution Steps
1	Ensure the following conditions are met for test entry: •DP has successfully completed SAS Discovery and Authentication with SAS Test Harness •DP has successfully registered 2 CBSD with SAS Test Harness, each with cbsdId=Ci, i={1,2} •DP has received a valid grant with grantId = Gi, i={1,2} for each CBSD •Both CBSD are in Grant State AUTHORIZED and actively transmitting within the bounds of their grants. Invoke trigger on UUT to Relinquish Grant from the SAS Test Harness
2	DP with two CBSDs sends Relinquishment Request with two objects to the SAS Test Harness. This may occur in a separate message per CBSD, or together in a single message with array of 2. Verify DP sends a Relinquishment Request message for each CBSD. This may occur in a separate message per CBSD, or together in a single message with array of 2. Verify Relinquishment Request message contains all required parameters properly formatted for each CBSD, specifically, for CBSDi: •cbsdId = Ci •grantId = Gi
3	If a separate Relinquishment Request message was sent for each CBSD by the DP, the SAS Test Harness shall respond to each request message with a separate response message. If a single Relinquishment Request message was sent by the DP containing a 2-object array (one per CBSD), the SAS Test Harness shall respond with a single Response message containing a 2-object array. Parameters for each CBSD within the Relinquishment Response Message shall be as follows: •cbsdId = Ci •No grantId •responseCode = Ri
4	After completion of step 3, SAS Test Harness will not provide any positive response (responseCode=0) to further request messages from the UUT.
5	Monitor the RF output of each UUT from start of test until 60 seconds after Step 3 is complete. This is the end of the test. Verify: A. UUT stopped RF transmission at any time between triggering the relinquishment and UUT sending the relinquishment request

Test Case ID	Description
WINNF.FT.D.DRG.2	Domain Proxy Successful Deregistration
#	Test Execution Steps
1	<p>Ensure the following conditions are met for test entry: •Each UUT has successfully registered with SAS Test Harness •Each UUT is in the authorized state •DP has successfully completed SAS Discovery and Authentication with SAS Test Harness •DP has successfully registered 2 CBSID with SAS Test Harness, each with cbsdId=Ci, i={1,2} •DP has received a valid grant with grantId = Gi, i={1,2} for each CBSID •Both CBSID are in Grant State AUTHORIZED and actively transmitting within the bounds of their grants. Invoke trigger to deregister each UUT from the SAS Test Harness</p>
2	<p>UUT sends a Relinquishment request and receives Relinquishment response with responseCode=0</p>
3	<p>Verify DP sends a Deregistration Request message for each CBSID. This may occur in a separate message per CBSID, or together in a single message with array of 2. Verify Deregistration Request message contains all required parameters properly formatted for each CBSID, specifically, for CBSIDi: •cbsdId = Ci</p>
4	<p>If a separate Deregistration Request message was sent for each CBSID by the DP, the SAS Test Harness shall respond to each request message with a separate response message. If a single Deregistration Request message was sent by the DP containing a 2-object array (one per CBSID), the SAS Test Harness shall respond with a single Response message containing a 2-object array. Parameters for each CBSID within the Deregistration Response shall be as follows: •cbsdId = Ci •responseCode = 0</p>
5	<p>After completion of step 4, SAS Test Harness will not provide any positive response (responseCode=0) to further request messages from the UUT.</p>
6	<p>Monitor the RF output of each UUT from start of test until 60 seconds after Step 4 is complete. This is the end of the test. Verify: •UUT stopped RF transmission at any time between triggering the deregistration and either A OR B occurs: A.UUT sending a Registration Request message, as this is not mandatory B.UUT sending a Deregistration Request message</p>

Test Case ID	Description
WINNF.FT.D.DRG.4	Domain Proxy Deregistration responseCode=102
#	Test Execution Steps
1	Ensure the following conditions are met for test entry: •DP has successfully completed SAS Discovery and Authentication with SAS Test Harness •DP has successfully registered 2 CBSD with SAS Test Harness, each with cbsdId=Ci, i={1,2} •DP has received a valid grant with grantId = Gi, i={1,2} for each CBSD •Both CBSD are in Grant State AUTHORIZED and actively transmitting within the bounds of their grants. Invoke trigger to deregister each UUT from the SAS Test Harness
2	UUT sends a Relinquishment request and receives Relinquishment response with responseCode=0 for each CBSD
3	Verify DP sends a Deregistration Request message for each CBSD. This may occur in a separate message per CBSD, or together in a single message with array of 2. Verify Deregistration Request message contains all required parameters properly formatted for each CBSD, specifically, for CBSDi: •cbsdId = Ci
4	If a separate Deregistration Request message was sent for each CBSD by the DP, the SAS Test Harness shall respond to each request message with a separate response message. If a single Deregistration Request message was sent by the DP containing a 2-object array (one per CBSD), the SAS Test Harness shall respond with a single Response message containing a 2-object array. Parameters for each CBSD within the Deregistration Response Message shall be as follows: •No cbsdId in either response •responseCode = Ri •
5	After completion of step 3, SAS Test Harness will not provide any positive response (responseCode=0) to further request messages from the UUT.
6	Monitor the RF output of each UUT from start of test until 60 seconds after Step 4 is complete. This is the end of the test. Verify: •UUT stopped RF transmission at any time between triggering the deregistration and either A OR B occurs: A.UUT sending a Registration Request message, as this is not mandatory B.UUT sending a Deregistration Request message

Test Case ID	Description
WINNF.FT.C.DRG.5	Deregistration responseCode=103
#	Test Execution Steps
1	Ensure the following conditions are met for test entry: •UUT has successfully completed SAS Discovery and Authentication with SAS Test Harness •UUT has successfully registered with SAS Test Harness, with cbsdId=C •UUT has received a valid grant with grantId = G •UUT is in Grant State AUTHORIZED and is actively transmitting within the bounds of its grant. Invoke trigger to deregister UUT from the SAS Test Harness
2	UUT sends a Relinquishment request and receives Relinquishment response with responseCode=0
3	UUT sends Deregistration Request to SAS Test Harness with cbsdId = C
4	The SAS Test Harness sends the Deregistration Response Message to UUT with: •No cbsdId •responseCode = 103
5	After completion of step 3, SAS Test Harness will not provide any positive response (responseCode=0) to further request messages from the UUT.
6	Monitor the RF output of the UUT from start of test until 60 seconds after Step 4 is complete. This is the end of the test. Verify: • UUT stopped RF transmission at any time between triggering the deregistration and either A OR B occurs: • A. UUT sending a Registration Request message, as this is not mandatory • B. UUT sending a Deregistration Request message

Test Case ID	Description
WINNF.FT.C.SCS.1	Successful TLS connection between UUT and SAS Test Harness
#	Test Execution Steps
1	•UUT shall start CBSD-SAS communication with the security procedure •The UUT shall establish a TLS handshake with the SAS Test Harness using configured certificate. •Configure the SAS Test Harness to accept the security procedure and establish the connection
2	•Make sure that Mutual authentication happens between UUT and the SAS Test Harness. •Make sure that UUT uses TLS v1.2 •Make sure that cipher suites from one of the following is selected, •TLS_RSA_WITH_AES_128_GCM_SHA256 •TLS_RSA_WITH_AES_256_GCM_SHA384 •TLS_ECDHE_ECDSA_WITH_AES_128_GCM_SHA256 •TLS_ECDHE_ECDSA_WITH_AES_256_GCM_SHA384 •TLS ECDHE RSA WITH AES 128 GCM SHA256
3	A successful registration is accomplished using one of the test cases described in section 6.1.4.1, depending on CBSD capability. •UUT sends a registration request to the SAS Test Harness and the SAS Test Harness sends a Registration Response with responseCode = 0 and cbsdId.
4	Monitor the RF output of the UUT from start of test until 60 seconds after Step 3 is complete. This is the end of the test. Verify: •UUT shall not transmit RF

Test Case ID	Description
WINNF.FT.C.SCS.2	TLS failure due to revoked certificate
#	Test Execution Steps
1	<ul style="list-style-type: none"> •UUT shall start CBSD-SAS communication with the security procedure •The UUT shall establish a TLS handshake with the SAS Test Harness using configured certificate. •Configure the SAS Test Harness to accept the security procedure and establish the connection
2	<ul style="list-style-type: none"> •Make sure that Mutual authentication happens between UUT and the SAS Test Harness. •Make sure that UUT uses TLS v1.2 •Make sure that cipher suites from one of the following is selected, <ul style="list-style-type: none"> •TLS_RSA_WITH_AES_128_GCM_SHA256 •TLS_RSA_WITH_AES_256_GCM_SHA384 •TLS_ECDHE_ECDSA_WITH_AES_128_GCM_SHA256 •TLS_ECDHE_ECDSA_WITH_AES_256_GCM_SHA384 •TLS_ECDHE_RSA_WITH_AES_128_GCM_SHA256
3	A successful registration is accomplished using one of the test cases described in section 6.1.4.1, depending on CBSD capability. •UUT sends a registration request to the SAS Test Harness and the SAS Test Harness sends a Registration Response with responseCode = 0 and cbsdId.
4	Monitor the RF output of the UUT from start of test until 60 seconds after Step 3 is complete. This is the end of the test. Verify: •UUT shall not transmit RF

Test Case ID	Description
WINNF.FT.C.SCS.3	TLS failure due to expired server certificate
#	Test Execution Steps
1	•UUT shall start CBSD-SAS communication with the security procedures
2	<ul style="list-style-type: none"> •Make sure that UUT uses TLS v1.2 for security establishment. •Make sure UUT selects the correct cipher suite. •UUT shall use CRL or OCSP to verify the validity of the server certificate. •Make sure that Mutual authentication does not happen between UUT and the SAS Test Harness.
3	UUT may retry for the security procedure which shall fail
4	SAS Test-Harness shall not receive any Registration request or any application data.
5	Monitor the RF output of the UUT from start of test until 60 seconds after Step 3 is complete. This is the end of the test. Verify: •UUT shall not transmit RF

Test Case ID	Description
WINNF.FT.C.SCS.4	failure when SAS Test Harness certificate is issued by an unknown CA
#	Test Execution Steps
1	•UUT shall start CBSD-SAS communication with the security procedures
2	•Make sure that UUT uses TLS v1.2 for security establishment. •Make sure UUT selects the correct cipher suite. •UUT shall use CRL or OCSP to verify the validity of the server certificate. •Make sure that Mutual authentication does not happen between UUT and the SAS Test Harness.
3	UUT may retry for the security procedure which shall fail.
4	SAS Test-Harness shall not receive any Registration request or any application data.
5	Monitor the RF output of the UUT from start of test until 60 seconds after Step 3 is complete. This is the end of the test. Verify: •UUT shall not transmit RF

Test Case ID	Description
WINNF.FT.C.SCS.5	TLS failure when certificate at the SAS Test Harness is corrupted
#	Test Execution Steps
1	•UUT shall start CBSD-SAS communication with the security procedures
2	•Make sure that UUT uses TLS v1.2 for security establishment. •Make sure UUT selects the correct cipher suite. •UUT shall use CRL or OCSP to verify the validity of the server certificate •Make sure that Mutual authentication does not happen between UUT and the SAS Test Harness.
3	UUT may retry for the security procedure which shall fail.
4	SAS Test-Harness shall not receive any Registration request or any application data.
5	Monitor the RF output of the UUT from start of test until 60 seconds after Step 3 is complete. This is the end of the test. Verify: •UUT shall not transmit RF

Test Case ID	Description
WINNF.PT.C.HBT.1	<p>Given a combination of grant parameters: {lowFrequency = FL, highFrequency= FH, Occupied Bandwidth (OBW), where $OBW \leq (FH - FL)$, maxEirp = Pi}, this test case enables the UUT to obtain a grant with those parameters, to allow verification that the UUT complies to the maxEirp value of the grant.</p> <p>The test execution steps below will yield a single measurement case. The test steps are to be repeated for each power measurement step, Pi, $i = \{1...N\}$.</p>
#	Test Execution Steps
1	<p>Ensure the following conditions are met for test entry:</p> <ul style="list-style-type: none"> •UUT has successfully completed SAS Discovery and Authentication with the SAS Test Harness •UUT has registered with the SAS, with CBSID ID = C •UUT has a single valid grant G with parameters {lowFrequency = FL, highFrequency = FH, maxEirp = Pi}, with grant in AUTHORIZED state, and grantExpireTime set to a value far past the duration of this test case <p>Note: in order for the UUT to request a grant with the parameters {lowFrequency, highFrequency, maxEirp}, the SAS Test Harness may need to provide appropriate guidance in the availableChannel object of the spectrumInquiry response message, and the operationParam object of the grant response message. Alternately, the UUT vendor may provide the ability to set those parameters on the UUT so that the UUT will request a grant with those parameters.</p>
2	<p>UUT and SAS Test Harness perform a series of Heartbeat Request/Response cycles, which continues until the other test steps are complete. Messaging for each cycle is as follows:</p> <ul style="list-style-type: none"> •UUT sends Heartbeat Request, including: ocbid = C ograntId = G •SAS Test Harness responds with Heartbeat Response, including: ocbid = C ograntId = G otransmitExpireTime = current UTC time + 200 seconds oreponseCode = 0
3	<p>Tester performs power measurement on RF interface(s) of UUT, and verifies it complies with the maxEirp setting, Pi. The RF measurement method is out of scope of this document, but may include additional configuration of the UUT, as required, to fulfil the requirements of the power measurement method. Note: it may be required for the vendor to provide a method or configuration to bring the UUT to a mode which is required by the measurement methodology. Any such mode is vendor-specific and depends upon UUT behavior and the measurement methodology.</p>