



Baicells mBS1105 Base Station Installation Guide

V100R001C00

About This Document

This document is a guidance of mBS1105 hardware installation for installation personnel, which includes the preparation of installation tools and supporting materials before installation, the demands of installation environment, installation of base station, connection of cable and power on.

Accomplish the installation of the device according to this guide, the installation personnel can avoid potential damage to the device during the installation procedure, which makes sure the subsequent good running of the device.

Copyright Notice

Baicells copyrights this specification. No part of this specification may be reproduced in any form or means, without the prior written consent of Baicells.

Disclaimer

This specification is preliminary and is subject to change at any time without notice. Baicells assumes no responsibility for any errors contained herein. For more information, please consult our technical engineers.

Disposal of Electronic and Electrical Waste



Pursuant to the WEEE EU Directive, electronic and electrical waste must not be disposed of with unsorted waste. Please contact your local recycling authority for disposal of this product.

Revision Record

Date	Version	Description
24 Mar, 2017	V1.0	Initial Released.

Contact Us

Baicells Technologies Co., Ltd.North America

Address: 555 Republic Drive, Suite 200 Plano, TX 75074

E-mail: support_na@baicells.com

Phone: +1-972-800-1157

Website: <http://www.baicells.com/>

Contents

1.	Product Overview	1
1.1	Introduction	1
1.2	Features.....	1
1.3	Appearance	2
1.4	Technical Specification	3
1.4.1	Hardware Specification.....	3
1.4.2	Software Specification	4
1.4.3	Environment Specification.....	5
2.	Out-of-Box Audit	6
3.	Installation Preparation	7
3.1	Support Materials.....	7
3.2	Installation Tools	7
3.3	Installation Environment.....	8
3.3.1	Locational Requirements.....	8
3.3.2	Environmental Requirements.....	8
3.3.3	Space Requirements	8
3.4	Personnel Requirements.....	9
3.5	Lightening and Grounding Protection.....	9
3.6	Weatherproof Protection.....	10
4.	Base Station Installation.....	11
4.1	Installation Procedure.....	11
4.2	Install the Mounting Bracket and Handle	11
4.3	Install GPS Antenna	12
4.4	Install on Pole	13
4.5	Install on Wall.....	15
4.6	Connect Cable	16
4.6.1	Requirement for Cable Laying	16

4.6.2	Connect GPS Antenna.....	16
4.6.3	Connect RF Cable.....	17
4.6.4	Connect Optical Fiber	17
4.6.5	Connect Ethernet Cable.....	17
4.6.6	Connect Power Connector.....	17
4.6.7	Connect Ground Cable.....	18
4.7	Install Antenna Feeder System.....	18
4.7.1	Install Omnidirectional Antennas	18
4.7.2	Install Directional Antennas.....	20
5.	Power On	22
Appendix A	Additional Information.....	23
A.1	Antenna Information.....	23
A.2	Maximum Output Power.....	24
A.3	Regulatory Compliance	24

Figures

Figure 1-1 mBS1105 Appearance	2
Figure 1-2 mBS1105 Interfaces and Indicators.....	2
Figure 3-1 Installation Space Requirement.....	9
Figure 3-2 Antenna Weatherproofing	10
Figure 4-1 Installation Procedure of mBS1105	11
Figure 4-2 Install the Mounting Bracket	12
Figure 4-3 Location of Grounding Screws.....	18
Figure 4-4 Omnidirectional Antenna Installation (1).....	19
Figure 4-5 Omnidirectional Antenna Installation (2).....	20
Figure 4-6 Assembling Procedure of Directional Antennas	20
Figure 4-7 Transportation the Antennas in the Height	21
Figure 4-8 Directional Antenna Installation	21
Figure 5-1 LED Indicators	22

Tables

Table 1-1 mBS1105 Interface Description.....	3
Table 1-2 mBS1105 Interface Indicators	3
Table 2-1 Shipping List	6
Table 3-1 Support Materials for Installing Base Station	7
Table 3-2 Environmental Requirements of the Base Station	8
Table 5-1 mBS1105 Indicator Description	22
Table 5-2 Antenna Information	23

1. Product Overview

1.1 Introduction

Baicells mBS1105 is a high performance outdoor 3.65GHz micro base station based on TD-LTE technology, which is developed by Baicells. The mBS1105 supports wired backhaul connections to backbone networks, and provides LTE access to user terminals, implemented voice and data service transmissions.

The mBS1105 makes use of the current transmission resources to reduce the operator's investment, implement the low-cost construction of LTE networks and enhance indoor coverage, thereby providing high-speed broadband access for users in assembly occupations.

The mBS1105 can be widely used by telecom operators, broadband operators, enterprises, and so on.

1.2 Features

- Adopt the integration design of baseband and RF.
- Based on 3GPP international standard TD-LTE technology; provide high speed data service; support a maximum transfer rate of DL: 110Mbit/s, UL: 20Mbit/s.
- Support flexible uplink and downlink time slot ratio: 1(2:2), 2(1:3), and high speed data transmission.
- Support 10MHz/20MHz operation bandwidth.
- Support copper (RJ-45) and optical port backhaul, flexible to deploy.
- Security services to provide timely protection against potential security risks and illegal intrusion.
- Support simple and convenient local and remote web management.
- Integration as required, easy to installation and deployment, accurate coverage and improved network capacity.
- Support network management functions, which includes the management, monitoring and maintenance.

1.3 Appearance

The mBS1105 base station appearance is shown in Figure 1-1.

Figure 1-1 mBS1105 Appearance

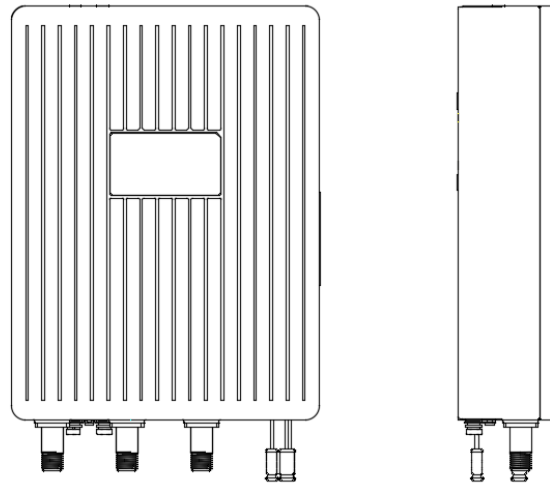

The mBS1105 interfaces and indicators are shown in Figure 1-2.

Figure 1-2 mBS1105 Interfaces and Indicators

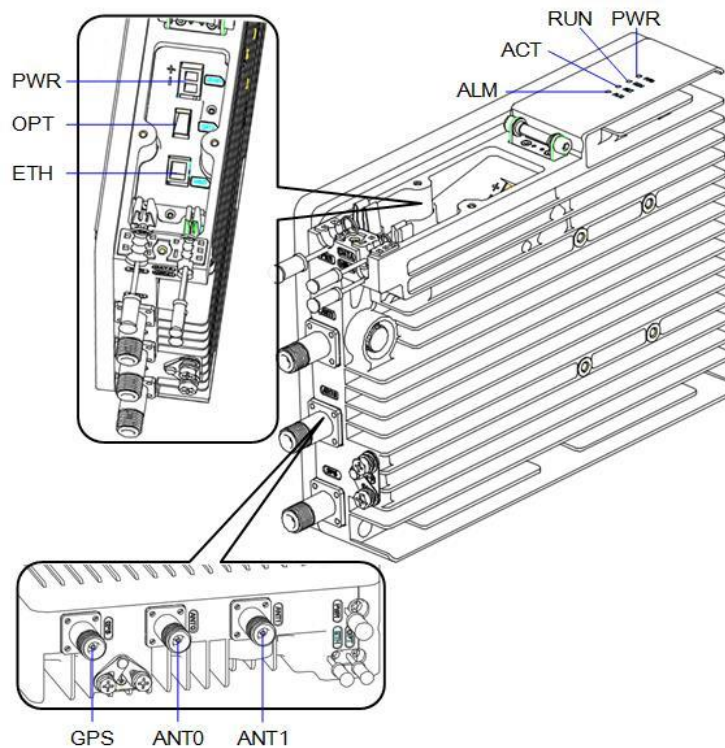

The mBS1105 interfaces are described in Table 1-1.

Table 1-1 mBS1105 Interface Description

Interface Name	Description
PWR	Power interface: +48V (+42V~+60V) DC
GPS	External GPS antenna, N-female connector.
ANT0	External antenna 0, N-female connector.
OPT	Optical interface, connect to external transmission network, used for data backhaul.
ETH	RJ-45 interface, used for debug or data backhaul.
ANT1	External antenna 1, N-female connector.

The mBS1105 interface indicators are described in Table 1-2.

Table 1-2 mBS1105 Interface Indicators

Identity	Color	Status	Description
PWR	Green	Steady On	Power On
		OFF	No Power Supply
RUN	Green	Fast flash: 0.125s on, 0.125s off	The board is loading.
		Slow flash: 1s on, 1s off	The board is normal.
		OFF	No power input or board fault
ACT	Green	Steady On	The transmitting channel works normally
		OFF	The transmitting channel works abnormally
ALM	Red	Steady On	Hardware alarm, e.g. VSWR alarm
		OFF	No alarm

1.4 Technical Specification

1.4.1 Hardware Specification

Item	Description
LTE Mode	LTE TDD
LTE Frequency	3650 MHz ~ 3700 MHz
Channel Bandwidth	10 MHz, 20 MHz
Max Output Power	33 dBm

Item	Description
Receiving sensitivity	-102 dBm
Synchronization Mode	<ul style="list-style-type: none"> Air-interface same frequency synchronization GPS synchronization
Backhaul Mode	Optical and RJ-45 Ethernet backhaul
MIMO	2*2MIMO
Dimension	227mm (L) * 305mm (W) * 74mm (H)
Installation Method	Pole mounted, wall mounted
Antenna	External high gain antenna
Overall Power	< 50 W
Power	48V DC
Weight	About 4.4kg

Note:

The test method of receiving sensitivity is proposed by the 3GPP TS 36.104, which is based on 5MHz bandwidth, FRC A1-3 in Annex A.1 (QPSK, R=1/3, 25RB) standard.

1.4.2 Software Specification

Item	Description
LTE Standard	LTE TDD 3GPP Release 9
Maximum Throughput	<ul style="list-style-type: none"> 20MHz: DL 110Mbps, UL 20Mbps 10MHz: DL 55Mbps, UL 9Mbps
Business Capacity	32 concurrent users (support software upgrading the users to 96)
Modulation Mode	QPSK, 16QAM, 64QAM
Voice Solution	Support CSFB, VoLTE, SRVCC
Traffic Offload (optional)	Support LIPA/SIPTO, which is Local IP Access and Selected IP Traffic Offload for short
SON	Self-organizing network: support plug and play, automatic start, optimization and configuration
RAN Sharing	Support
Network Management Interface	Support TR069 interface protocol
Northbound Interface	Support Web service, Socket, FTP and other interface modes
MTBF	≥ 150000 hours
MTTR	≤ 1 hour
Maintenance	Support remote/local maintenance, based on SSH protocol
	Support remote maintenance

Item	Description
	Support online status management
	Support performance statistics
	Support failure management
	Support configuration management
	Support local or remote software upgrading and loading
	Support log
	Support connectivity diagnosis
	Support automatic start and configuration
	Support alarm reporting

1.4.3 Environment Specification

Item	Description
Operating Temperature	-40°C ~ 55°C
Humidity	5% ~ 100%
Change Rate of Temperature	1°C/min
Atmospheric Pressure	70kPa ~ 106kPa
IP Protection Grade	IP66
Lightning Protection	Power interface: differential mode: ±10KA common mode: ±20KA

2. Out-of-Box Audit

Before opening the box, make sure the package is in good condition, undamaged and not wet. During the unpacking, avoid potential damaging impacts from hits or excessive force. Once unpacked, check the contents to see if they are consistent with that in the shipping list shown in Table 2-1.

Table 2-1 Shipping List

Number	Item	Quantity	Description
1	mBS1105 base station	1	Check whether the base station's tag is consistent with the requirement
2	Power supply	1	100V ~ 277V AC to 48V DC
3	Power terminal	1	2 wires green terminal
4	GPS antenna and RF cable	1	-
5	Installation bracket and its screws	-	Omega 4 Installation bracket 1 M10*160 outer hex bolt 4 M10 flat gasket 10 M10 spring cushion 10 M10 screw 10 M8*80 expansion bolt 2
6	eNodeB bracket and its screws	-	eNodeB fixing bracket 1 M6*16 hex combination screw 4
7	GPS mounting bracket and its screws	1	Fixed accessories of GPS M4*14 screw 2
8	Ground terminal	2	Used for making ground cable.
9	All-weather electrical tape	1	Installation accessories
10	Mastic tape	1	Installation accessories
11	Warranty	1	-
12	Certification	1	-
13	User guide	1	-

Note:

During the unpacking, if the outer package is damaged or wet, stop unpacking and find the cause. Report the issue to the vendor. For any shortage or damage that is identified, report the local vendor within 10 days.

3. Installation Preparation

3.1 Support Materials













Prepare the following support materials accordingly, as given in Table 3-1.

Table 3-1 Support Materials for Installing Base Station

Item	Description
Power cable	< AWG16, e.g., AWG14 Shorter than 100m (330 feet)
Antenna RF cable	50 ohm feeder
Optical fiber	Single mode optical fiber
Ethernet cable	Outdoor CAT6 Shorter than 100m (330 feet)
Antenna	Omnidirectional, or directional antenna
Ground cable	16mm ² yellow-green wire

3.2 Installation Tools

The following tools are needed during the installation.

				
Level bar	Marking pen	Knife	Vise	Wrench
				
Percussion drill and some drill heads	hammer	Cross screw driver	Cable vice	Tape measure
				
5mm L-shape allen wrench	T7 screwdriver head	Ladder		

3.3 Installation Environment

3.3.1 Locational Requirements

Environments with high-temperatures, harmful gases, unstable voltages, volatile vibrations, loud noises, flames, explosives, and electromagnetic interference (large radar stations, transmitting stations, transformer substations) are not suitable for the operation of mBS1105, and thus should be avoided.

Places prone to have impounded water, soaking, leakage, or condensation, should also be avoided.

Factors like climate, hydrology, geology, earthquake, electric power, and transportation should be taken into consideration in the construction process so that a proper location can be chosen to meet the communication engineering environmental requirements, as well as the technical requirements of network planning and communication equipment.

3.3.2 Environmental Requirements

Table 3-2 gives the base station's environmental requirements with regards to temperature, humidity, and voltage.

Table 3-2 Environmental Requirements of the Base Station

Item	Range	Typical value
Humidity	-40°C ~ 55°C	25°C
Relative humidity (no condensation)	0% ~ 100%	5% ~ 95%
Safety voltage	42V ~ 58V	48V

3.3.3 Space Requirements

After the eNodeB has installed, the enough space must be provided for operation and maintenance. And for heat dissipation and normal running of the eNodeB, the space must be planed before installation, as shown in Figure 3-1.

Figure 3-1 Installation Space Requirement

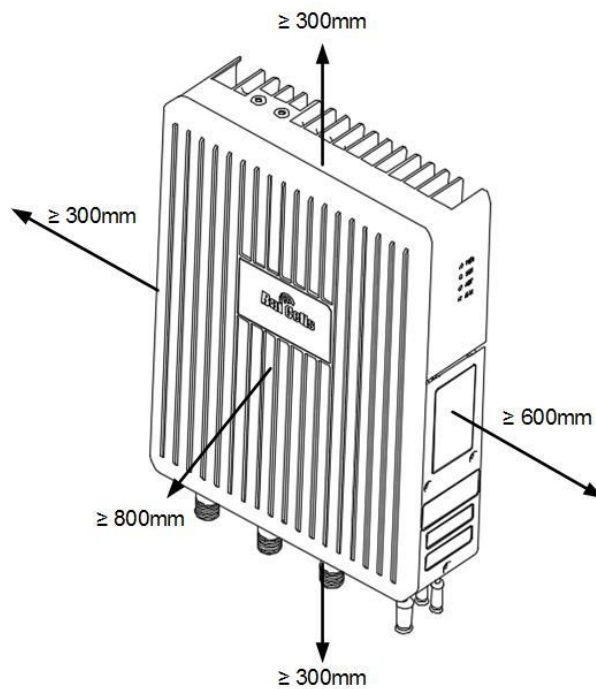

3.4 Personnel Requirements

The installation personnel must master the basic safe operation knowledge, through the training, and having the corresponding qualifications..

3.5 Lightning and Grounding Protection



CAUTION:

It is unlikely to happen but since the LTE eNodeB is very sophisticated equipment so we would recommend you to test it on the ground to make sure everything is functioning before install on the tower.

The operator must prepare external lightning protector to protect the GPS, external antenna and RJ-45 port.

Grounding Notes:

- The ground wire adopts yellow-green wire that is no smaller than 16 mm².
- Grounding principle: as near as possible.
- The eNodeB connects to the reliable outdoor grounding point (earth) through one ground screw.

- The connection of the grounding points and the ground bar need to be tight and reliable. Rustproofing the terminals is required. This can be done with rust preventing paint, anti-oxidation coatings, grease, and so on.

3.6 Weatherproof Protection

1. To weatherproof the connections, wrap them with all-weather electrical tape and mastic tape, as shown in Figure 3-2.

Figure 3-2 Antenna Weatherproofing

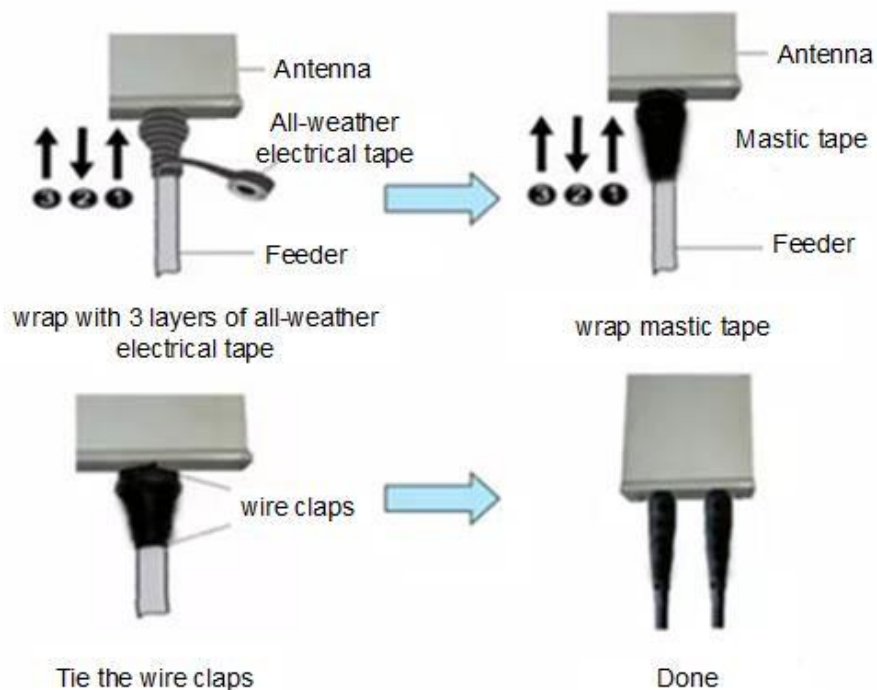

2. Be aware that at least three layers of tapes are needed, and make sure that the wrapping direction of the last layer is from the bottom up. The last layer should be tight enough to keep it from cracking.

4. Base Station Installation

4.1 Installation Procedure

The installation procedure of mBS1105 is given in Figure 4-1.

Figure 4-1 Installation Procedure of mBS1105

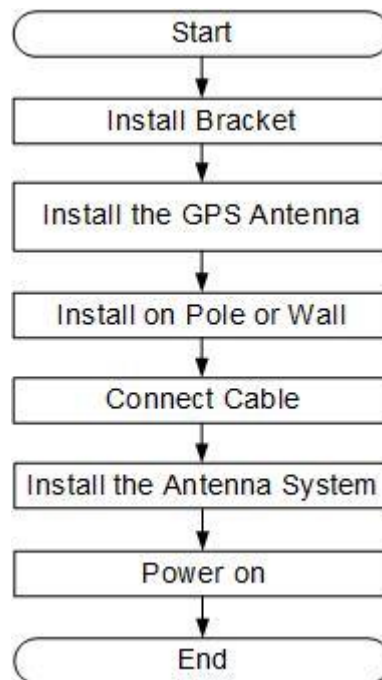

4.2 Install the Mounting Bracket and Handle

Using the M6*16 hex screw to fix the bracket on back side of the mBS1105, as shown in Figure 4-2.

Figure 4-2 Install the Mounting Bracket

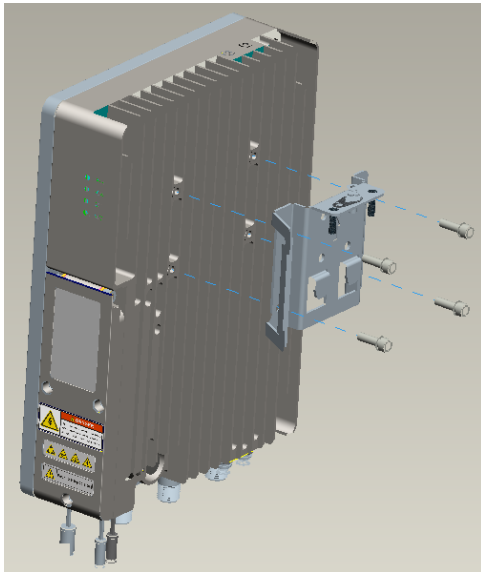
**Caution:**

The arrow of the installation bracket must be upward.

4.3 Install GPS Antenna

Installation requirements on the GPS antenna:

- No major blocking from buildings in the vicinity. Keep the rooftop buildings a distance away from the GPS. Make sure the space atop within 90 degrees (at least 45 degrees) is not blocked by any buildings.
- Avoid installing the GPS in the vicinity of any other transmitting and receiving devices. Avoid interference from other transmitting antennas to the GPS antennas.
- Should be installed within 45 degrees to the lightning rod.

The following describes the steps of the GPS antenna installation.

1. Using the M4*14 screws to fix the GPS mounting bracket on the base station.

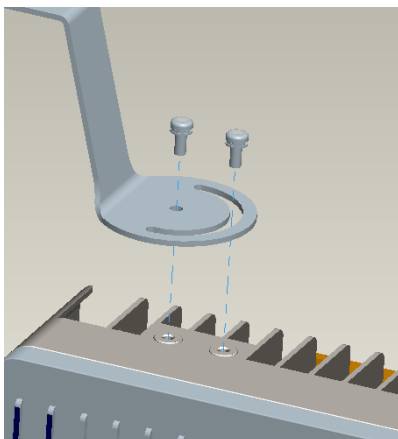

2. Pass the GPS antenna through the hole on the GPS mounting bracket.
3. Installation is complete.



4.4 Install on Pole

Required diameter of the pole: 40mm ~ 100mm.

Suggest the installation height higher than 120cm, and the installation space requirements meet the requirements in “3.3.3Space Requirements”.

1. As the following figure, assemble the bracket for pole installation, and fasten the four nuts. .

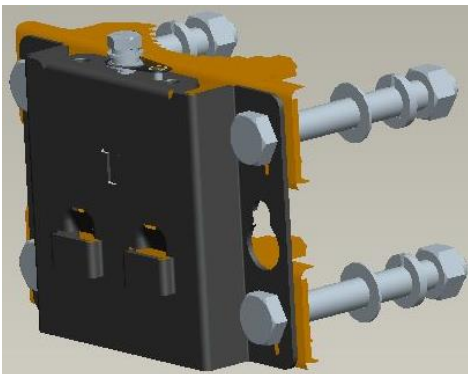

2. Make sure the installation height of the eNodeB, fit the thread rod of the assembled bracket to the pole, and then pass the omega through the threaded rods, and fasten the four nuts.

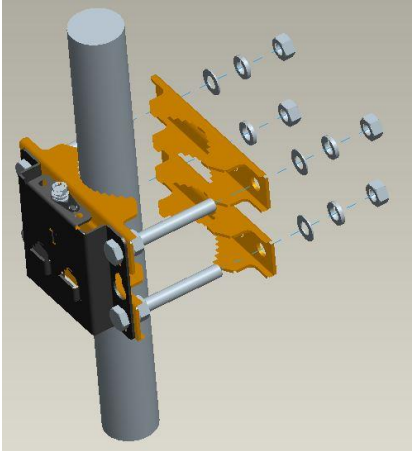

Caution:

The arrow of the installation bracket must be upward.

3. As the following figure, hung the two pin on the eNodeB bracket to the installation bracket, push the eNodeB until the hook block to the eNodeB bracket

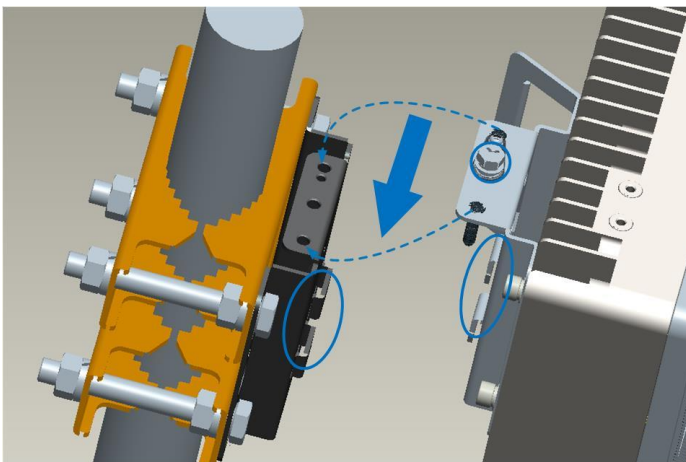

4. Fasten the screw on the top of the eNodeB bracket using cross screwdriver.
5. The installation is complete.



4.5 Install on Wall

The wall must bear four times of the eNodeB weight.

1. Fit the base station on the wall, and mark the drilling locations.

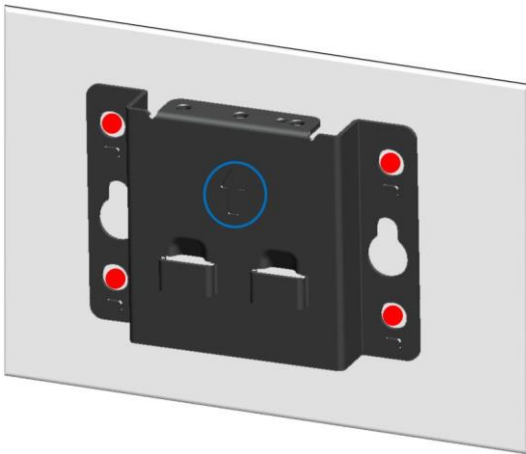

Caution:

The arrow of the installation bracket must be upward.

2. Drill four 10mm diameter and 70mm depth holes in the wall by following the marked locations.
3. Check the up/down direction of the installation rack, and then fix the eNodeB to the wall using M8*80 expansion screws.
4. Refer to the installation steps on pole, fix the eNodeB on wall.
5. Fasten the screw on the top of the eNodeB bracket using cross screwdriver.

6. The installation is complete.

4.6 Connect Cable

4.6.1 Requirement for Cable Laying

General requirements:

- Bending radius requirement of feeder cable: 7/8" > 250mm, 4/5" > 380mm
- Bending radius requirement of jumper cable: 1/4" > 35mm, 1/2" (super soft) > 50mm, 1/2" (ordinary) > 127mm
- Bending radius requirement of power cable and grounding cable: > tripled of the diameter of cable
- The minimum bend radius of the optical fiber is the 20 times of the diameter of optical fiber.
- Binding the cables according the type of the cable, the intertwining and crossing is forbidden.
- The label should be paste after the cable laying.

Optical fiber laying requirement:

- The circling and twisting is forbidden during the laying.
- The binding on the turning is forbidden.
- The pulling and weigh down the optical fiber is forbidden.
- The redundant optical fiber must enwind the dedicated device.

Grounding laying requirement:

- The grounding cable must connect to the grounding point.
- The grounding cable must be separate with the signal cables, remaining a certain distance to avoid the interruption of signal.

4.6.2 Connect GPS Antenna

1. Connect one end of the GPS RF cable to the GPS antenna. It is necessary for the GPS antenna interfaces to be weatherproofed. Refer to 3.6 Weatherproof Protection for more detail.
2. Connect the other end of the GPS RF cable to the GPS interface of the eNodeB, which also need the weatherproof protection.

4.6.3 Connect RF Cable

1. Open the dust cap of **ANT0** and **ANT1** interface.
2. Connect one end of the RF cable to **ANT0** and **ANT1** interface of the eNodeB and fasten them with wrench.
3. Connect the other end of the RF cable to the external antenna.
4. It is necessary for **ANT0** and **ANT1** interfaces to be weatherproofed. Refer to 3.6 Weatherproof Protection for more detail.

4.6.4 Connect Optical Fiber

1. Unscrew three screws on the cover of wiring cavity using M4 cross screwdriver and open the wiring cavity.
2. Connect the optical fiber to the **OPT** interface in the wiring cavity.
3. Lay optical fibers along the wire groove, and stretch out the wiring cavity from the **OPT** hole.

The redundant fiber should wind neatly.

4.6.5 Connect Ethernet Cable

1. Connect the Ethernet cable to the **ETH** interface in the wiring cavity.
2. Lay Ethernet cable along the wire groove, and stretch out the wiring cavity from the **ETH** hole.

4.6.6 Connect Power Connector

Make the power cable so it can reach the distance between the installation site and the power supply device. Strip the 12mm insulating layer with wire stripper, which is inserted into the power connector.

It is recommended that the power cord length is kept below 100m (330 feet).

The connection steps of power cable is as follows.

1. Connect the power cable to the **PWR** interface in the wiring cavity.
2. The power cable lays along the lint slot, and stretch out the wiring cavity from the **PWR** hole
3. The input of the power adaptor connects to the outlet.

- If the outlet is indoors, place the power adaptor indoors.
 - If the outlet is outdoors, place the power adaptor in a water proof box.
4. After the cable connection is complete in the wiring cavity, fasten the screws on the cover to close the wiring cavity using M4 cross screwdriver.

4.6.7 Connect Ground Cable

Make the grounding cable according the actual situation of the installation site.

The mBS1105 provides two grounding screws, which is located on the bottom of the base station, as shown in Figure 4-3.

Figure 4-3 Location of Grounding Screws

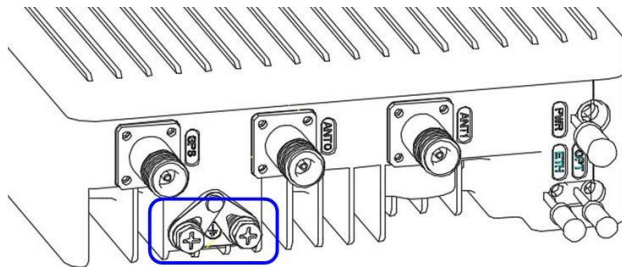

1. Unscrew one grounding screw, connect one end of the grounding cable to the grounding screw, and fasten it again.
2. The other end of the ground cable needs to connect to a good grounding point.

4.7 Install Antenna Feeder System

There are two kinds of outdoor antennas, omnidirectional outdoor antennas and directional outdoor antennas, whose installation will be introduced in the following, respectively.

4.7.1 Install Omnidirectional Antennas

One should pay attention to the followings while installing the omnidirectional outdoor antenna:

- The diameter of the pole for omnidirectional outdoor antennas is required to be 35mm ~ 50mm. A typical case is to use the 50mm-diameter round-steel-made pole (with details depending on the specific antenna type).
- Make sure that the top of pole and the clamp beneath the antenna are at the same level, after installing the omnidirectional outdoor antenna on the pole.

- Make sure that the antenna is high enough to meet the coverage requirement, and that the antenna top falls within the 45 degrees safety angle towards the lightning rod, as shown in Figure 4-4. In principle, no lightning rod can be welded to pole (no metal object is allowed within 1m of the horizontal direction of the omnidirectional antennas), when installing the omnidirectional antennas. Instead, an independent lightning rod should be settled between the two poles, where the lightning rod must be high enough to keep all antennas under its protection cover.

Figure 4-4 Omnidirectional Antenna Installation (1)

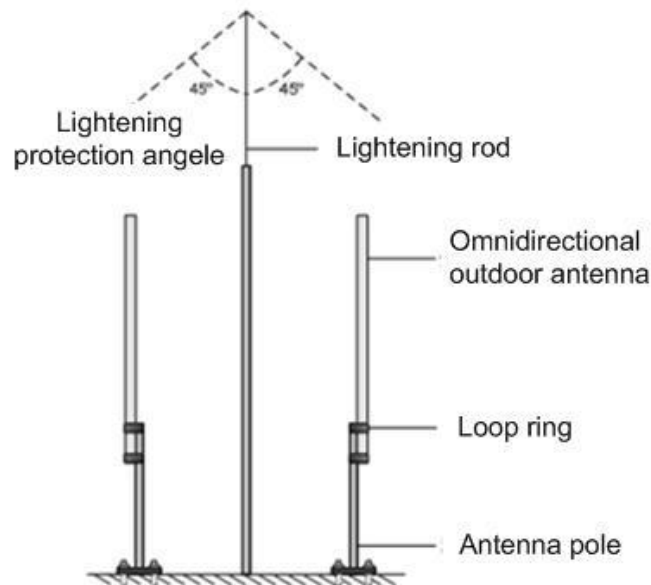

In case is impossible to install an independent lightning rod due to environmental limitations, the installation method shown in Figure 4-5 can be used. Be aware that the pole supporting the lightning rod should be kept at least 1m away from the omnidirectional outdoor antennas.

Figure 4-5 Omnidirectional Antenna Installation (2)

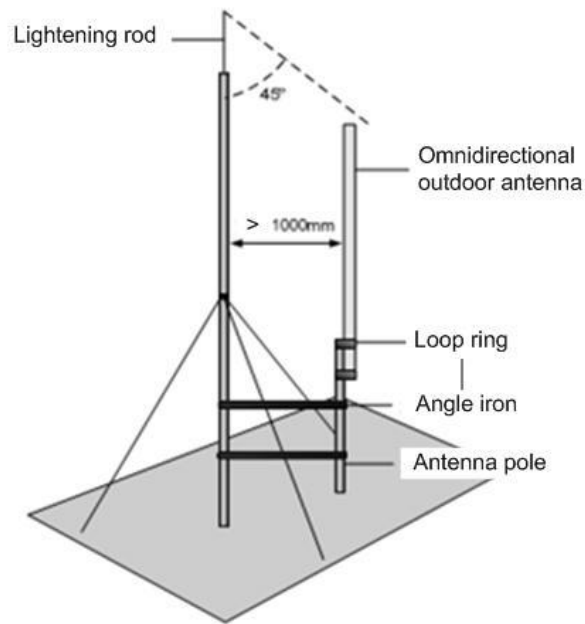

4.7.2 Install Directional Antennas

1. First, assemble the antennas, as shown in Figure 4-6.

Figure 4-6 Assembling Procedure of Directional Antennas



2. To install it on the iron tower, use a pulley to transport the antenna assembled to the platform on the iron tower, as shown in Figure 4-7. Following the safety rules when working at these heights.

Figure 4-7 Transportation the Antennas in the Height

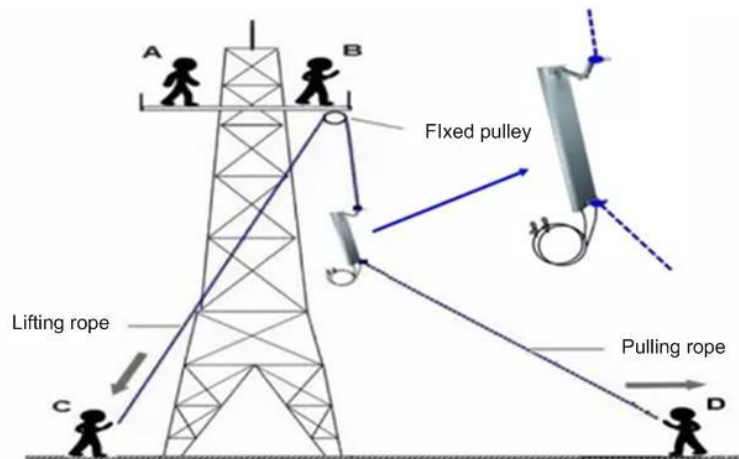

3. Fix the pole vertically to the ground or concrete pillars on the rooftop using expansion screws, and fasten it with steel wires. Then, mount the directional outdoor antenna onto the pole using the installation rack, as shown in Figure 4-8.

Figure 4-8 Directional Antenna Installation

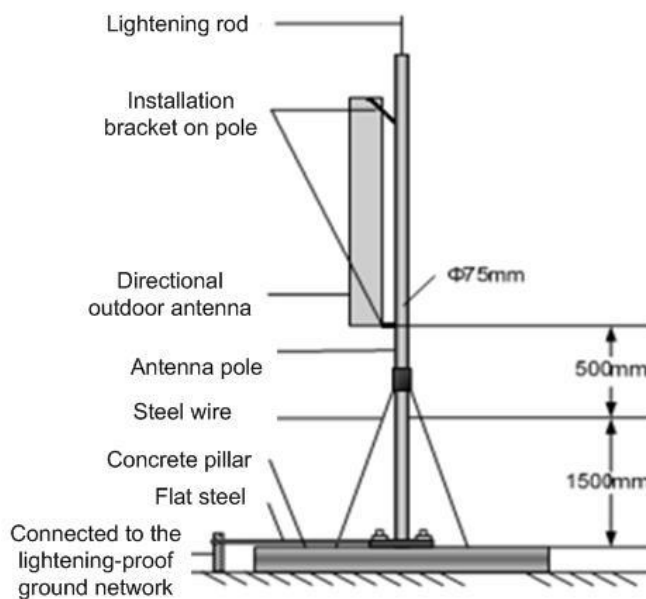

4. When the base station has been installed in a proper position, connect all the cables and wires.
5. Run tests, then seal and weatherproof all the connections after the testing has successfully completed. Refer to 3.6 Weatherproof Protection.

5. Power On

Power on the mBS1105, and the indicators will light up, as shown in Figure 5-1.

Figure 5-1 LED Indicators

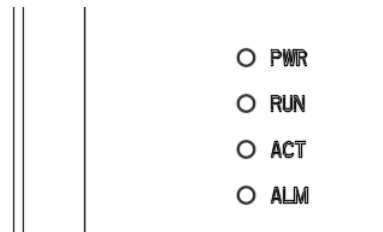

The explanation of the indicator signal is given in Table 5-1.

Table 5-1 mBS1105 Indicator Description

Type	Color	Status	Meaning
PWR	Green	ON	Have power input
		OFF	No power input
RUN	Green	Fast blink: 0.125s on, 0.125s off	Single board loading
		Slow blink: 1s on, 1s OFF	Single board running well
		OFF	No power input, or single board failure
ALM	Red	ON	Hardware warning status, e.g., cable connection failure warning
		OFF	No warning
ACT	Green	ON	Active cell
		OFF	Inactive cell

Appendix A Additional Information

A.1 Antenna Information

The following is a list of antennas that are certified for use. Customers can choose different antennas according to the environment.

Table 5-2 Antenna Information

Antenna Type	Manufacturer	Model Number	Antenna Max Gain(dBi)
External Planar Antenna Dual Pole	Kenbotong Technology Co., Ltd.	KBT90DP13-3338 AT0	13
External Planar Antenna Dual Pole	Kenbotong Technology Co., Ltd.	KBT90DP14-3338 AT0	14
External Planar Antenna Dual Pole	Baicells Technologies Co., Ltd	ANT-3G11-R-65-E DT0	11
External Planar Antenna Dual Pole	Baicells Technologies Co., Ltd	ANT-3G7-R-65-ED T0	7
External Omnidirectional Antenna Single Pole	Kenbotong Technology Co., Ltd.	TQJ-3500AC6	6
External Omnidirectional Antenna Single Pole	Kenbotong Technology Co., Ltd.	TQJ-3500AC3	3
External Omnidirectional Antenna Single Pole	Kenbotong Technology Co., Ltd.	TQJ-3500AT8	8

A.2 Maximum Output Power

The maximum output power can be set as follows:

Antenna Max Gain (dBi)	10Log(Number of antennas)	Channel BW (MHz)	Max output power (dBm)	EIRP (dBm)
13	3	10	23	39
		20	23	39
14		10	22	39
		20	22	39
11		10	25	39
		20	25	39
7		10	29	39
		20	29	40
6		10	30	39
		20	30	39
3		10	33	39
		20	33	39
8	10	28	39	
	20	28	39	

A.3 Regulatory Compliance

FCC Compliance

This device complies with part 15 of the FCC Rules. Operation is subject to the following two conditions: (1) This device may not cause harmful interference, and (2) this device must accept any interference received, including interference that may cause undesired operation.

Any Changes or modifications not expressly approved by the party responsible for compliance could void the user's authority to operate the equipment.

This equipment has been tested and found to comply with the limits for a Class A

digital device, pursuant to part 15 of the FCC Rules. These limits are designed to provide reasonable protection against harmful interference when the equipment is operated in a commercial environment. This equipment generates, uses, and can radiate radio frequency energy and, if not installed and used in accordance with the instruction manual, may cause harmful interference to radio communications. Operation of this equipment in a residential area is likely to cause harmful interference in which case the user will be required to correct the interference at his own expense.

Warning

This equipment complies with FCC radiation exposure limits set forth for an uncontrolled environment. This equipment should be installed and operated with minimum distance 30 cm between the radiator & your body.

ISED Compliance

This device complies with Innovation, Science, and Economic Development Canada licence-exempt RSS standard(s).

Operation is subject to the following two conditions: (1) This device may not cause interference, and (2) This device must accept any interference, including interference that may cause undesired operation of the device.

Le présent appareil est conforme aux CNR d'Innovation, Science et Développement

économique Canada applicables aux appareils radio exempts de licence.

L'exploitation est autorisée aux deux conditions

suivantes:

- (1) l'appareil ne doit pas produire de brouillage, et
- (2) l'utilisateur de l'appareil doit accepter tout brouillage radioélectrique subi, même si le brouillage est susceptible d'en compromettre le fonctionnement.

The antenna(s) used for this transmitter must be installed to provide a separation distance of at least 30 cm from all persons and must not be collocated or operating in conjunction with any other antenna or transmitter, End-Users must be provided with transmitter operation conditions for satisfying RF exposure compliance.