



mBS1100 Base Station Installation Guide

V100R001C00

About This Document

This document is a guidance of mBS1100 hardware installation for installation personnel, which includes the preparation of installation tools and supporting material before installation, the demands of installation environment, installation of base station, connection of cable and power on.

Accomplish the installation of the device according to this guide, the installation personnel can avoid potential damage to the device during the installation procedure, which makes sure the subsequent good running of the device.

Copyright Notice

Baicells copyrights this specification. No part of this specification may be reproduced in any form or means, without the prior written consent of Baicells.

Disclaimer

This specification is preliminary and is subject to change at any time without notice. Baicells assumes no responsibility for any errors contained herein. For more information, please consult our technical engineers.

Revision Record

Date	Version	Description
30 June, 2016	01	Initial Released.
14 July, 2016	02	Update according to the hardware change.
30 Oct, 2016	03	Update according to the hardware change.

Contact Us

Baicells Technologies Co., Ltd.North America

Address: 555 Republic Drive, Suite 200 Plano, TX 75074

E-mail: support_na@baicells.com

Phone: +1-972-800-1157

Website: <http://www.baicells.com/>

Contents

1.	Product Overview	1
1.1	Introduction	1
1.2	Features	1
1.3	Appearance	2
1.4	Technical Specification.....	3
1.4.1	Hardware Specification	3
1.4.2	Software Specification.....	4
1.4.3	Environment Specification.....	5
1.4.4	FCC Compliance.....	5
2.	Out-of-Box Audit	7
2.1	Shipping List	7
2.2	Base Station Accessories	8
3.	Installation Preparation	10
3.1	Support Materials	10
3.2	Installation Tools	10
3.3	Installation Environment.....	11
3.3.1	Locational Requirements.....	11
3.3.2	Environmental Requirements	11
3.4	Lightening and Grounding Protection	11
3.5	Weatherproof Protection	12
4.	Base Station Installation.....	13
4.1	Installation Procedure	13
4.2	Connect Cable	13
4.2.1	Structure of Cable Connection.....	13
4.2.2	Connect GPS Antenna.....	14
4.2.3	Connect RF Cable	16
4.2.4	Connect Ethernet Cable.....	16

4.2.5	Connect Power Connector	17
4.2.6	Connect Ground Cable	20
4.3	Install the Mounting Bracket and Handle	21
4.4	Install GPS Antenna	23
4.5	Install on Pole	25
4.6	Install on Wall.....	26
4.7	Install Antenna Feeder System.....	26
4.7.1	Install Omnidirectional Antennas.....	26
4.7.2	Install Directional Antennas.....	28
5.	Power On.....	30

Figures

Figure 1-1 mBS1100 Appearance	2
Figure 1-2 mBS1100 Interfaces.....	2
Figure 3-1 Antenna Weatherproofing	12
Figure 4-1 Installation Procedure of mBS1100	13
Figure 4-2 mBS1100 Wire Connection Structure	14
Figure 4-3 Connect the Ground Wire of GPS Lightning Arrestor	15
Figure 4-4 Connect the GPS RF Cable to the GPS Lightning Arrestor	15
Figure 4-5 Weatherproof protection of the GPS RF Cable connection.....	15
Figure 4-6 Connect GPS RF Cable.....	16
Figure 4-7 Connect RF Cable	16
Figure 4-8 Separate the Ethernet Weatherproof Connector	16
Figure 4-9 Install the Ethernet weatherproof Connector	17
Figure 4-10 Connect the Ethernet Interface.....	17
Figure 4-11 Power Adaptor Input and Output.....	18
Figure 4-12 Disassemble the Power weatherproof Connector	18
Figure 4-13 Unscrew the compression screw	19
Figure 4-14 Description of A and B terminal.....	19
Figure 4-15 Connect the PWR Interface	20
Figure 4-16 Location of Grounding Screws.....	20
Figure 4-17 Connect GPS Lightning Arrestor Grounding Cable	21
Figure 4-18 Ground Cable Complete	21
Figure 4-19 Install the Mounting Bracket	22
Figure 4-20 Install the Handle	22
Figure 4-21 Installation of Mounting Bracket and Handle Completed	23
Figure 4-22 Omnidirectional Antenna Installation (1)	27
Figure 4-23 Omnidirectional Antenna Installation (2).....	27
Figure 4-24 Assembling Procedure of Directional Antennas	28
Figure 4-25 Transportation the Antennas in the Height	28

Figure 4-26 Directional Antenna Installation	29
Figure 5-1 LED Indicators.....	30

Tables

Table 1-1 mBS1100 Interface Description.....	2
Table 1-2 mBS1100 Interface Indicators	3
Table 2-1 Shipping List	7
Table 2-2 Base Station Accessories	8
Table 3-1 Support Materials for Installing Base Stations	10
Table 3-2 Environmental Requirements of the Base Station	11
Table 4-1 Connection Serial Number Description	14
Table 5-1 mBS1100 Indicator Description	30

1. Product Overview

1.1 Introduction

Baicells mBS1100 is a high performance outdoor 3.65GHz micro base station based on TD-LTE technology, which is developed by Baicells. The mBS1100 supports wired and wireless backhaul connections to backbone networks, and provides LTE access to user terminals, implemented voice and data service transmissions.

The mBS1100 makes use of the current transmission resources to reduce the operator's investment, implement the low-cost construction of LTE networks and enhance indoor coverage, thereby providing high-speed broadband access for users in assembly occupations.

The mBS1100 can be widely used by telecom operators, broadband operators, enterprises, and so on.

1.2 Features

- Adopt the integration design of baseband and RF.
- Based on 3GPP international standard TD-LTE technology; provide high speed data service; support a maximum transfer rate of DL: 110Mbit/s, UL: 20Mbit/s.
- Support flexible uplink and downlink time slot ratio: 1(2:2), 2(1:3), and high speed data transmission.
- Support 10MHz/20MHz operation bandwidth.
- Varied backhaul, flexible to deploy.
- Built-in DHCP Server, DNS Client and NAT functionality, providing a strong high speed routing ability.
- Security services to provide timely protection against potential security risks and illegal intrusion.
- Convenient and simple web management.
- Integration as required, easy to installation and deployment, accurate coverage and improved network capacity.
- Support network management functions, which includes the management, monitoring and maintenance.

1.3 Appearance

The mBS1100 base station appearance is shown in Figure 1-1.

Figure 1-1 mBS1100 Appearance



The mBS1100 interfaces are shown in Figure 1-2.

Figure 1-2 mBS1100 Interfaces



The mBS1100 interfaces are described in Table 1-1.

Table 1-1 mBS1100 Interface Description

Interface Name	Description
PWR	Power interface: +48V (+42V~+58V)
GPS	External GPS antenna, N-female connector.
ANT1	External antenna 1, N-female connector.

Interface Name	Description
DATA	Gigabit Ethernet interface, external transmission network.
MGMT	Gigabit Ethernet debug interface.
ANT2	External antenna 2, N-female connector.

The mBS1100 interface indicators are described in Table 1-2.

Table 1-2 mBS1100 Interface Indicators

Identity	Color	Status	Description
PWR	Green	Steady On	Power On
		OFF	No Power Supply
RUN	Green	Fast flash: 0.125s on, 0.125s off	The board is loading.
		Slow flash: 1s on, 1s off	The board is normal.
		OFF	No power input or board fault
ALM	Red	Steady On	Hardware alarm, e.g. VSWR alarm
		OFF	No alarm
ACT	Green	Steady On	The transmitting channel works normally
		OFF	The transmitting channel works abnormally

1.4 Technical Specification

1.4.1 Hardware Specification

Item	Description
LTE Mode	LTE TDD
LTE Frequency	3550 MHz ~ 3700 MHz
Channel Bandwidth	10 MHz, 20 MHz
Receiving sensitivity	-102 dBm
Synchronization Mode	A-interface synchronization (same or different frequency), 1588V2, GPS
Backhaul Mode	<ul style="list-style-type: none"> Wired backhaul: Ethernet; Wireless backhaul: WLAN, LTE Relay
MIMO	2*2MIMO
Dimension	330mm (L) * 220mm (W) * 105mm (H)
Installation Method	Pole mounted, wall mounted
Antenna	External 17dBi directional antenna

Item	Description
	Vertical beamwidth: 35° Horizontal beamwidth:65° Downtilt angle: 8.5° Height: 30m
Overall Power	< 65 W
Power	48V DC, AC adaptor
Weight	About 5kg

Note:

The test method of receiving sensitivity is proposed by the 3GPP TS 36.104, which is based on 5MHz bandwidth, FRC A1-3 in Annex A.1 (QPSK, R=1/3, 25RB) standard.

1.4.2 Software Specification

Item	Description
LTE Standard	LTE TDD 3GPP Release 9
Maximum Throughput	<ul style="list-style-type: none"> 20MHz: DL 110Mbps, UL 20Mbps 10MHz: DL 55Mbps, UL 7Mbps
Business Capacity	32 concurrent users, 96 RRC connection users
Scheduling Mode	Based on QoS scheduling
Modulation Mode	QPSK, 16QAM, 64QAM
Voice Solution	Support CSFB, VoLTE, SRVCC
Traffic Offload (optional)	Support LIPA/SIPTO, which is Local IP Access and Selected IP Traffic Offload for short
SON	Self-organizing network: support plug and play, automatic start, optimization and configuration
RAN Sharing	Support
Network Management Interface	Support TR069 interface protocol
Northbound Interface	Support Web service, Socket, FTP and other interface modes
MTBF	≥ 150000 hours
MTTR	≤ 1 hour
Maintenance	Support remote/local maintenance, based on SSH protocol
	Support remote maintenance
	Support online status management
	Support performance statistics
	Support failure management
	Support configuration management

Item	Description
	Support local or remote software upgrading and loading
	Support log
	Support connectivity diagnosis
	Support automatic start and configuration
	Support alarm reporting

1.4.3 Environment Specification

Item	Description
Operating Temperature	-40°C ~ 55°C
Humidity	5% ~ 100%
Change Rate of Temperature	1°C/min
Atmospheric Pressure	70kPa ~ 106kPa
IP Protection Grade	IP65
Lightning Protection	<ul style="list-style-type: none"> Power interface: differential mode: $\pm 10\text{KA}$ common mode: $\pm 20\text{KA}$ Ethernet interface: differential mode: $\pm 3\text{KA}$ common mode: $\pm 5\text{KA}$

1.4.4 FCC Compliance

This device complies with part 15 of the FCC Rules. Operation is subject to the following two conditions: (1) This device may not cause harmful interference, and (2) this device must accept any interference received, including interference that may cause undesired operation.

Any Changes or modifications not expressly approved by the party responsible for compliance could void the user's authority to operate the equipment.

This equipment has been tested and found to comply with the limits for a Class B digital device, pursuant to part 15 of the FCC Rules. These limits are designed to provide reasonable protection against harmful interference in a residential installation. This equipment generates uses and can radiate radio frequency energy and, if not installed and used in accordance with the instructions, may cause harmful interference to radio communications. However, there is no guarantee that interference will not occur in a particular installation. If this equipment does cause harmful interference to radio or television reception, which can be determined by turning the equipment off and on, the user is encouraged to try to correct the interference by one or more of the following

measures:

- Reorient or relocate the receiving antenna.
- Increase the separation between the equipment and receiver.
- Connect the equipment into an outlet on a circuit different from that to which the receiver is connected.
- Consult the dealer or an experienced radio/TV technician for help.

Warning:

This equipment complies with FCC radiation exposure limits set forth for an uncontrolled environment. This equipment should be installed and operated with minimum distance 62cm between the radiator & your body.

2. Out-of-Box Audit

2.1 Shipping List

Before opening the box, make sure the package is in good condition, undamaged and not wet. During the unpacking, avoid potential damaging impacts from hits or excessive force. Once unpacked, check the contents to see if they are consistent with that in the shipping list shown in Table 2-1.

Table 2-1 Shipping List

No.	Item	Quantity	Description
1	mBS1100	1	Check whether the base station's tag is consistent with the requirement
2	Power supply	1	100V ~ 277V AC to 48V DC adaptor
3	U type clamp mounting kit	2	Used for installation on pole, including U type clamp*2, omega*2, and M8 nut*4
4	mounting bracket on pole	2	Fixed accessories
5	Weather-proof DC Power connector	1	-
6	Weather-proof Ethernet connector	1	-
7	GPS antenna and RF cable	1	-
8	Handle	1	-
9	GPS mounting bracket	2	Fixed accessories, including GPS mounting bracket 1 and GPS mounting bracket 2
10	GPS Lightning Arrestor	1	-
11	Connector for extending power cable	1	Used for making extended power cable
12	Ground terminals	2	Used for making ground cable.
13	All-weather electrical tape and mastic tape	1	-
14	Warranty	1	-
15	Certification	1	-
16	User guide	1	-

Note:



During the unpacking, if the outer package is damaged or wet, stop unpacking and find the cause.









Report the issue to the vendor. For any shortage or damage that is identified, report the local vendor within 10 days.

2.2 Base Station Accessories

Table 2-2 shows the accessories of the base station mBS1100.

Table 2-2 Base Station Accessories

Accessory	Name
	GPS antenna
	GPS RF cable
	GPS antenna lightning arrestor
	U type clamp mounting kit
	Mounting bracket

Accessory	Name
	Handle
	AC/DC power adaptor
	Power cable lengthened connector
	3M all-weather mastic tape
	3M vinyl electrical tape
	GPS mounting bracket 1
	GPS mounting bracket 2
	Water-proof DC Power plug
	Water-proof Ethernet connector

3. Installation Preparation

3.1 Support Materials













Prepare the following support materials accordingly, as given in Table 3-1.

Table 3-1 Support Materials for Installing Base Stations

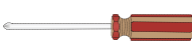
Item	Description
Power cable	< AWG16, e.g., AWG14 Shorter than 1150 feet
Antenna RF cable	50 ohm feeder
Ethernet cable	Outdoor CAT6 Shorter than 330 feet
Antenna	Omnidirectional, or directional antenna
Ground wire	16mm ² yellow-green wire

3.2 Installation Tools

The following tools are needed during the installation.

				
Level bar	Marking pen	Knife	Vise	Wrench
				
Percussion drill and some drill heads	hammer	Cross screw driver	Cable vice	Tape measure
				
5mm L-shape allen wrench	Torx screw driver	T7 screwdriver head	Ladder	

3.3 Installation Environment

3.3.1 Locational Requirements

Environments with high-temperatures, harmful gases, unstable voltages, volatile vibrations, loud noises, flames, explosives, and electromagnetic interference (large radar stations, transmitting stations, transformer substations) are not suitable for the operation of mBS1100, and thus should be avoided.

Places prone to have impounded water, soaking, leakage, or condensation, should also be avoided.

Factors like climate, hydrology, geology, earthquake, electric power, and transportation should be taken into consideration in the construction process so that a proper location can be chosen to meet the communication engineering environmental requirements, as well as the technical requirements of network planning and communication equipment.

3.3.2 Environmental Requirements

Table 3-2 gives the base station's environmental requirements with regards to temperature, humidity, and voltage.

Table 3-2 Environmental Requirements of the Base Station

Item	Range	Typical value
Temperature	-40°C ~ 55°C	25°C
Relative humidity (no condensation)	0% ~ 100%	5% ~ 95%
Safety voltage	42V ~ 58V	48V

3.4 Lightning and Grounding Protection



CAUTION:

It is unlikely to happen but since the LTE eNB is very sophisticated equipment so we would recommend you to test it on the ground to make sure everything is functioning before install on the tower.

Grounding Notes:

- The ground wire adopts yellow-green wire that is no smaller than 16 mm².
- Grounding principle: as near as possible.
- The mBS1100 is equipped with one GPS lightning arrestor. The GPS lightning

arrester needs to connect to one grounding screw via an M6 screw.

- Another grounding screw is used for connecting to the reliable outdoor grounding point (earth). The connecting point must be tin-soldered.
- The connection of the grounding points and the ground bar need to be tight and reliable. Rustproofing the terminals is required. This can be done with rust preventing paint, anti-oxidation coatings, grease, and so on.

3.5 Weatherproof Protection

1. To weatherproof the connections, wrap them with all-weather electrical tape and mastic tape, as shown in Figure 3-1.

Figure 3-1 Antenna Weatherproofing

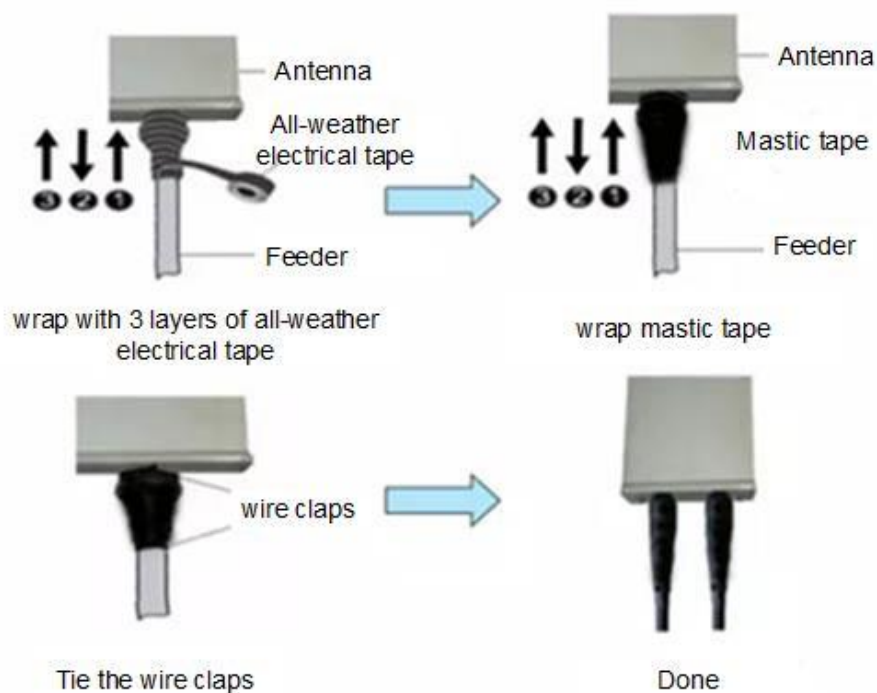

2. Be aware that at least three layers of tapes are needed, and make sure that the wrapping direction of the last layer is from the bottom up. The last layer should be tight enough to keep it from cracking.

4. Base Station Installation

4.1 Installation Procedure

The installation procedure of mBS1100 is given in Figure 4-1.

Figure 4-1 Installation Procedure of mBS1100

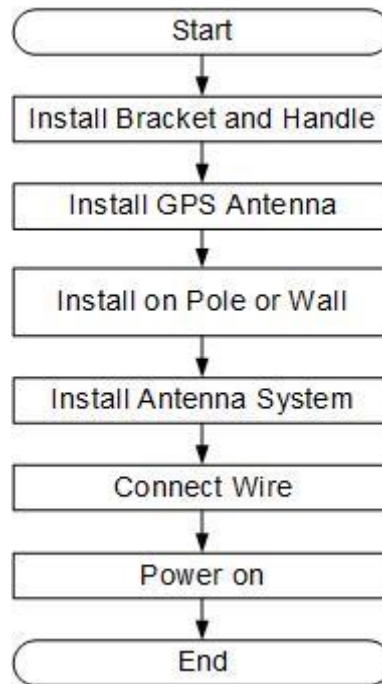

4.2 Connect Cable

4.2.1 Structure of Cable Connection

The wire connection relationship of the mBS1100 is shown in Figure 4-2.

Figure 4-2 mBS1100 Wire Connection Structure

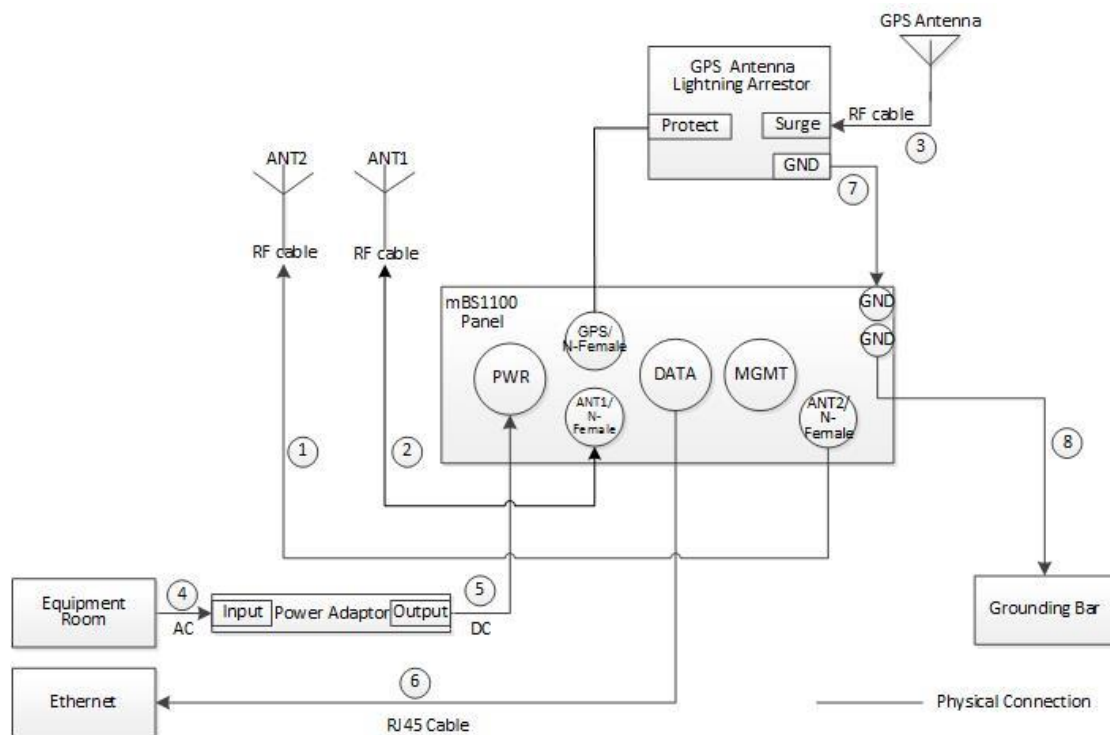

The description of the connection serial number is shown in Table 4-1.

Table 4-1 Connection Serial Number Description

No.	Initial Terminal	End of Connection	Cable Type
1	ANT2	RF cable	RF feeder line
2	ANT1	RF cable	RF feeder line
3	GPS antenna	GPS antenna lightning (Surge)	RF feeder line
4	Power supply system (AC)	Input end of power adaptor	Power supply line < AWG16
5	Output end of power adaptor	PWR interface of mBS1100	Power supply line < AWG16
6	Ethernet	DATA interface of mBS1100	RJ45 cable
7	Grounding point of GPS antenna lightning arrestor	Grounding screw of the base station (GND)	Yellow-green ground wire
8	Grounding screw of the base station (GND)	Grounding bar	Yellow-green ground wire

4.2.2 Connect GPS Antenna

1. Connect the ground wire of GPS lightning arrestor to the lightning arrestor, and

fasten it, as shown in Figure 4-3.

Figure 4-3 Connect the Ground Wire of GPS Lightning Arrestor



2. Connect one end of the GPS RF cable to the GPS lightning arrestor, as shown in Figure 4-4.

Figure 4-4 Connect the GPS RF Cable to the GPS Lightning Arrestor

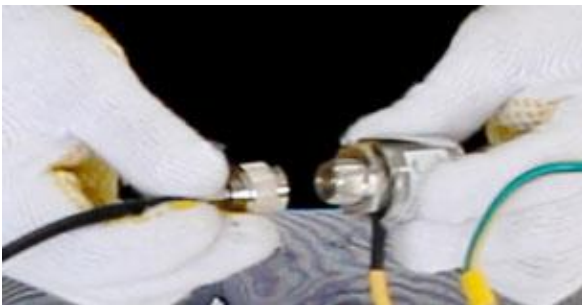

3. The connection point of RF cable needs to be weatherproofed. For more detail, refer to 3.5 Weatherproof Protection. After weatherproof protection, it is shown in Figure 4-5.

Figure 4-5 Weatherproof protection of the GPS RF Cable connection



4. Connect the GPS RF cable to the GPS antenna lightning arrestor. It is necessary for the GPS antenna interfaces to be weatherproofed. Refer to 3.5 Weatherproof Protection for more detail. The connection is complete shown in Figure 4-6.

Figure 4-6 Connect GPS RF Cable



4.2.3 Connect RF Cable

1. Connect the RF cable to the ANT1 and ANT2 interface of the mBS1100.
2. It is necessary for the ANT1 and ANT2 interfaces to be weatherproofed. Refer to 3.5 Weatherproof Protection for more detail. The connection is complete shown in Figure 4-7

Figure 4-7 Connect RF Cable



4.2.4 Connect Ethernet Cable

Weatherproof connector is adopted for Ethernet cables.

1. Disassemble the Ethernet weatherproof connector, as shown in Figure 4-8.

Figure 4-8 Separate the Ethernet Weatherproof Connector



- Slide the weatherproof connector components in turn. A click should be heard to ensure that the RJ45 connector has clip into the slot of weatherproof connector, as shown in Figure 4-9.

Figure 4-9 Install the Ethernet weatherproof Connector

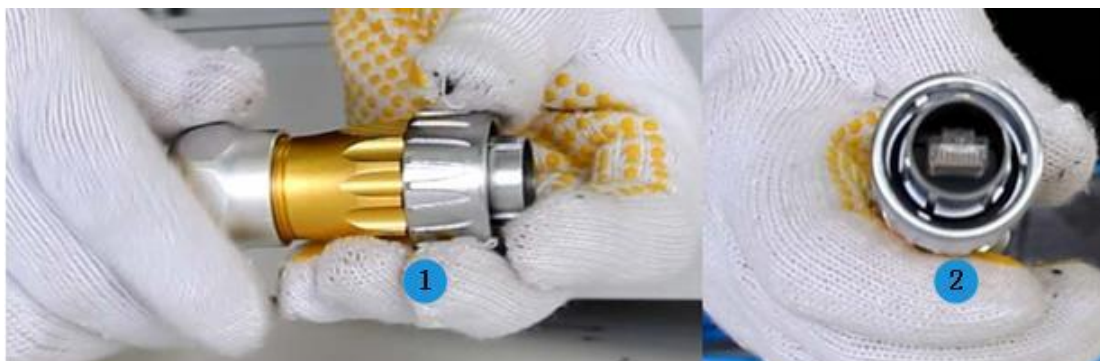

- Connect the weatherproof connector to the base station's **DATA** interface, and fasten it.

The alignment of bayonet when connection the weatherproof connector with the base station. Once aligned, twist it about 90 degrees clockwise.

- It is necessary for the Ethernet interface to be weatherproofed. Refer to 3.5 Weatherproof Protection for more detail. The connection is complete shown in Figure 4-10.

Figure 4-10 Connect the Ethernet Interface

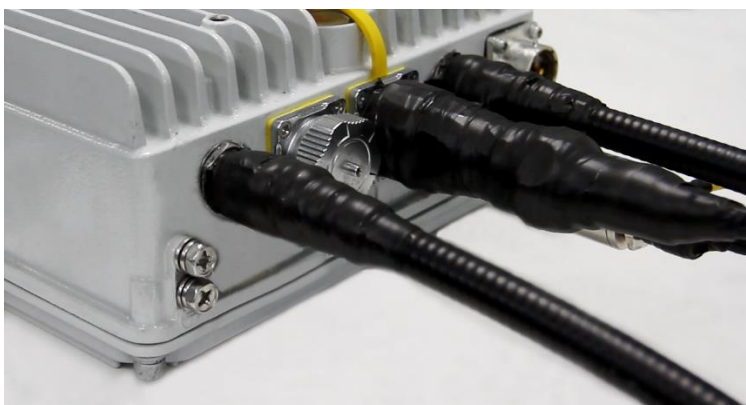

4.2.5 Connect Power Connector

Because it is not sure that the distance between the installation site and the power supply device, the two ends of power adapter are bare terminal end. The operators need to make power cable according to the actual conditions on installation site, and assemble power plug and power terminal on two ends of power adapter.

The weatherproof connector is adopted for power cables. First, you need to assemble the power weatherproof connector.

In the accessories for base station, the output end of the power adaptor has red and black power cord, where the red power cord is +48V, and the black power cord is 0V. The output voltage is 48V DC.

The connection relationship of the power cord and the power connector is shown in Figure 4-11.

Figure 4-11 Power Adaptor Input and Output

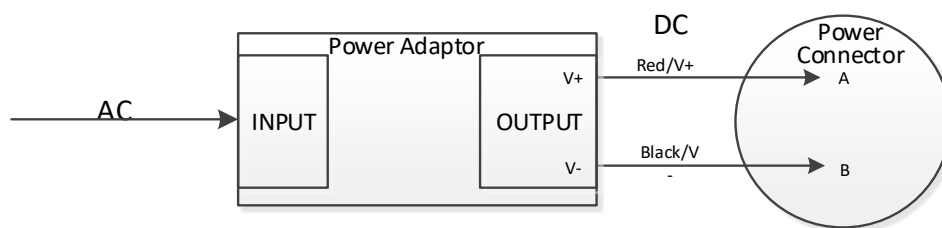

The input of power adaptor is the AC power supply, where the voltage range is 100V ~ 277V, 50/60Hz.

Make the power cable so it can reach the distance between the installation site and the power supply system.

Strip the 12mm insulating layer with wire stripper, which is inserted into the power connector.

It is recommended that the power cord length is kept below 1150 feet.

The connection steps of power cable is as follows.

1. Disassemble the power weatherproof connector into four parts, as shown in Figure 4-12.

Figure 4-12 Disassemble the Power weatherproof Connector

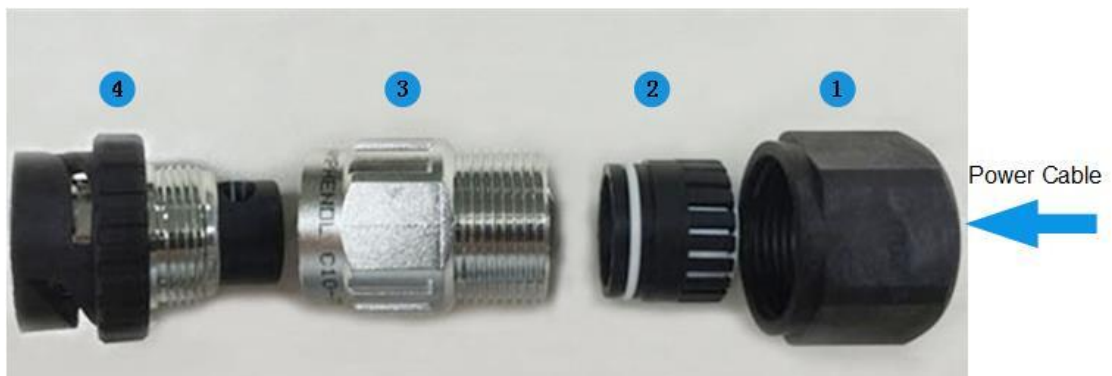

- Slide the weatherproof connector parts 1, 2 and 3 in turn.
- Unscrew the compression screw of the fourth part of the power connector with a T-15 torx screw driver, as shown in Figure 4-13 .

Figure 4-13 Unscrew the compression screw



- Insert the red power cable (48V) into terminal A, and insert the black power cable (0V) into terminal B, as shown in Figure 4-14.

Figure 4-14 Description of A and B terminal



- Tighten the power cord in the socket by using T-15 torx screw driver to crimp the threads, ensure the power cable crimping tight.
- Screw parts 1, 2, and 3 respectively. The assembly of the power connector is complete.
- Connect the power connector to the **PWR** interface of the base station and fasten it.
- Weatherproof the power connector. Refer to 3.5 Weatherproof Protection for more detail. The connection is shown in Figure 4-10.

Figure 4-15 Connect the PWR Interface



9. The input of the power adaptor connects to the outlet.
 - If the outlet is indoors, place the power adaptor indoors.
 - If the outlet is outdoors, place the power adaptor in a water proof box.

4.2.6 Connect Ground Cable

The mBS1100 provides two grounding screws, which is located on the connector panel side of the base station, as shown in Figure 4-16.

Figure 4-16 Location of Grounding Screws



1. Unscrew one grounding screw, connect the GPS lightning arrestor grounding cable to the grounding screw of the device, as shown in Figure 4-17.

Figure 4-17 Connect GPS Lightning Arrestor Grounding Cable



2. Unscrew another grounding screw, connect one end of the ground cable to the grounding screw of the device, as shown in Figure 4-18.

Figure 4-18 Ground Cable Complete

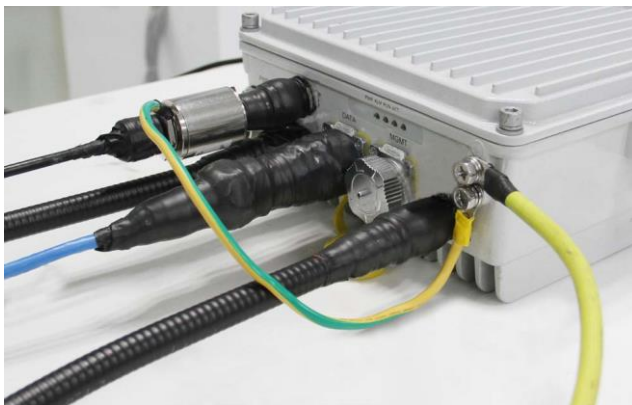

3. The other end of the ground cable needs to connect to a good ground (earth).

4.3 Install the Mounting Bracket and Handle

1. Use the M6*12 socket head screw to fix the bracket on both sides of the mBS1100, as shown in Figure 4-19.

Figure 4-19 Install the Mounting Bracket

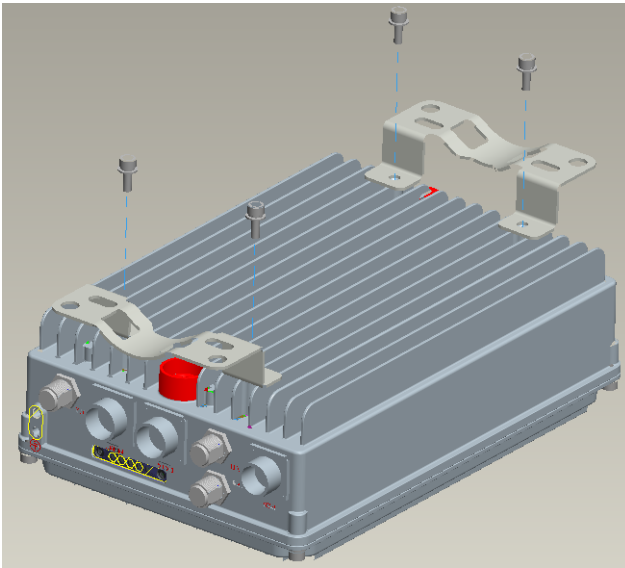

2. Use the M6*12 socket head screw to fix the handle on right side of the mBS1100, as shown in Figure 4-20.

Figure 4-20 Install the Handle

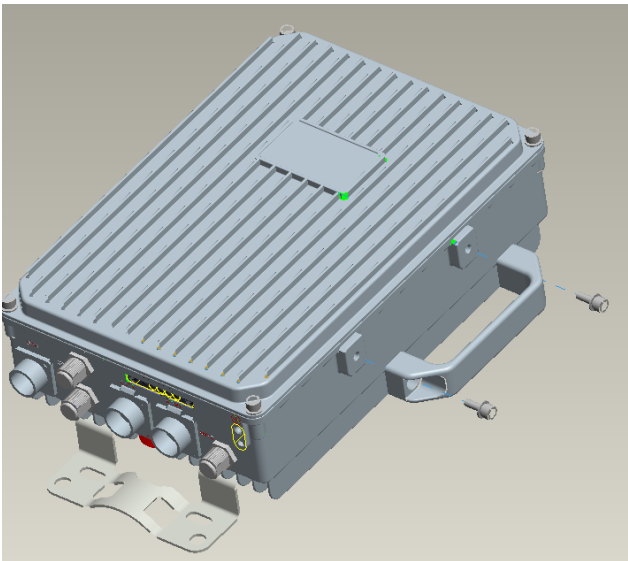

3. Figure 4-21 shows what it looks like when the installation of rack and handle is done.

Figure 4-21 Installation of Mounting Bracket and Handle Completed

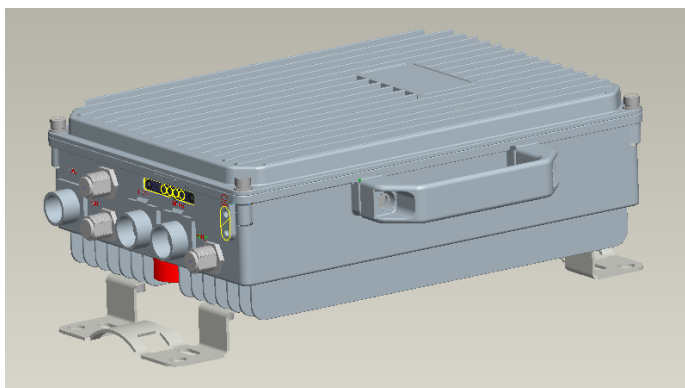

4.4 Install GPS Antenna

Installation requirements on the GPS antenna:

- No major blocking from buildings in the vicinity. Keep the rooftop buildings a distance away from the GPS. Make sure the space atop within 90 degrees (at least 45 degrees) is not blocked by any buildings.
- Avoid installing the GPS in the vicinity of any other transmitting and receiving devices. Avoid interference from other transmitting antennas to the GPS antennas.
- Should be installed within 45 degrees to the lightning rod.
- The GPS antenna lightning arrestor is required before connecting to the base station.

The following describes the steps of the GPS antenna installation.

1. Prepare the following assembly units for the GPS antenna installation.

Included GPS antenna, feed cable, GPS mounting bracket 1 and GPS mounting bracket 2.

2. Fit the GPS mounting bracket 2 on base station with M4 screws.

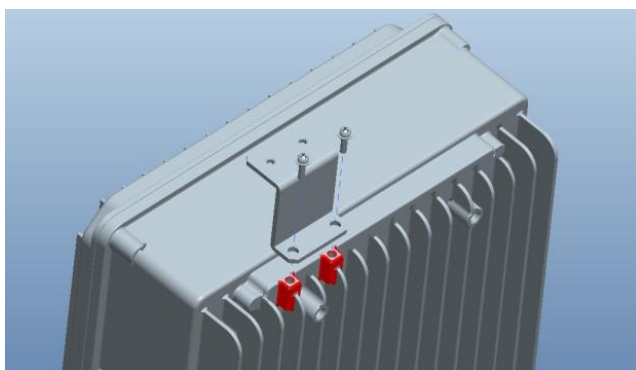

3. Fit the GPS mounting bracket 1 on the GPS mounting bracket 2 with an M4 screw according to the required angle.

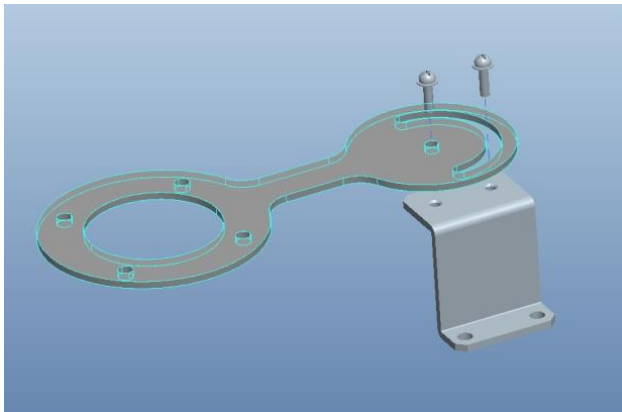

4. Fit the GPS antenna on the GPS mounting bracket 1 with an M4 screw. Vertical installation is required.

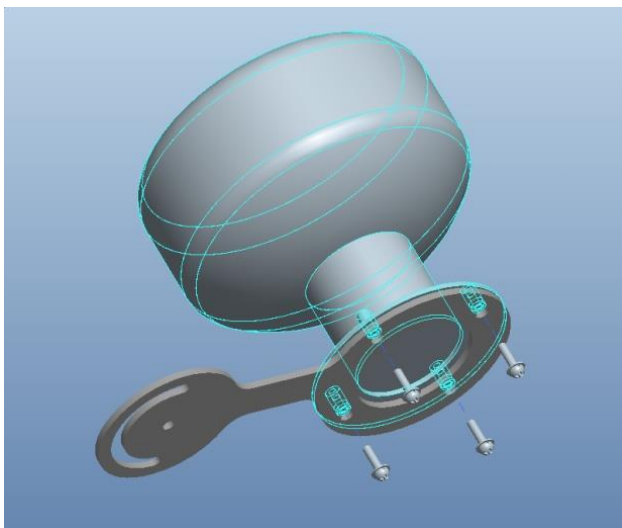

5. Installation complete.



4.5 Install on Pole

Required diameter of the pole: 30mm ~ 125mm.

1. The two U type clamps pass through the mounting brackets on both sides of the base station. Then the omegas pass through the threaded rods of the U type clamp, and fasten them with M8 nuts.

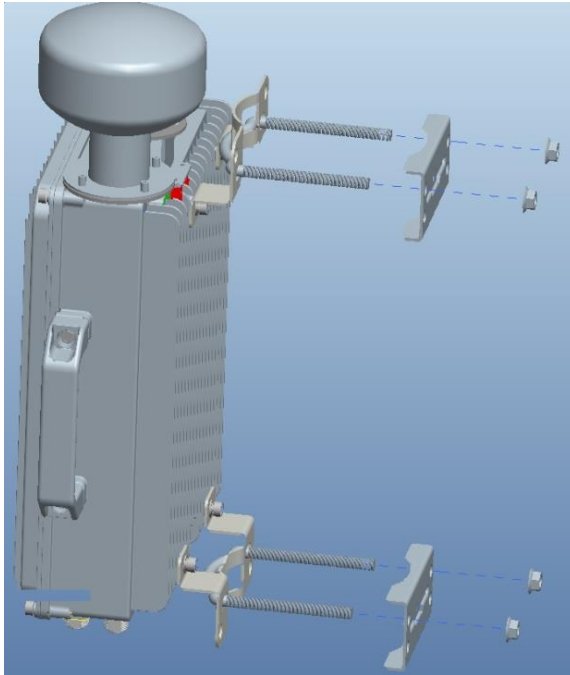

2. Hold the assembly up to the pole. Attach the two omegas to the threaded rods with M8 nuts.

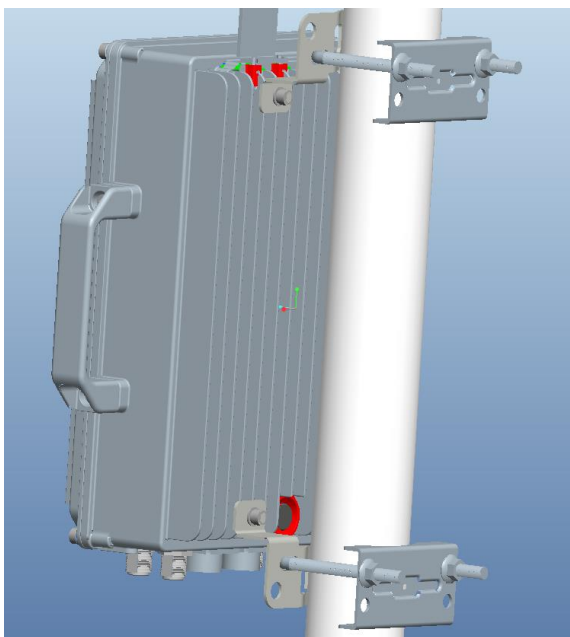

4.6 Install on Wall

1. Put the base station on the wall to install, and mark the drilling locations.

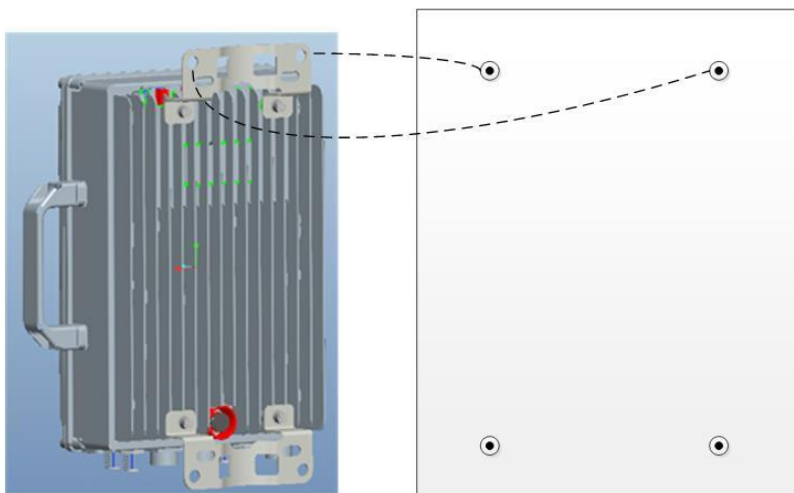

2. Drill four 10mm diameter and 70mm depth holes in the wall by following the marked locations.
3. Check the up/down direction of the installation rack, and then fix the base station to the wall using M8*80 expansion screws.

4.7 Install Antenna Feeder System

There are two kinds of outdoor antennas, omnidirectional outdoor antennas and directional outdoor antennas, whose installation will be introduced in the following, respectively.

4.7.1 Install Omnidirectional Antennas

One should pay attention to the followings while installing the omnidirectional outdoor antenna:

- The diameter of the pole for omnidirectional outdoor antennas is required to be 35mm ~ 50mm. A typical case is to use the 50mm-diameter round-steel-made pole (with details depending on the specific antenna type).
- Make sure that the top of pole and the clamp beneath the antenna are at the same level, after installing the omnidirectional outdoor antenna on the pole.
- Make sure that the antenna is high enough to meet the coverage requirement, and that the antenna top falls within the 45 degrees safety angle towards the lightning rod, as shown in Figure 4-22. In principle, no lightning rod can be welded to pole

(no metal object is allowed within 1m of the horizontal direction of the omnidirectional antennas), when installing the omnidirectional antennas. Instead, an independent lightning rod should be settled between the two poles, where the lightning rod must be high enough to keep all antennas under its protection cover.

Figure 4-22 Omnidirectional Antenna Installation (1)

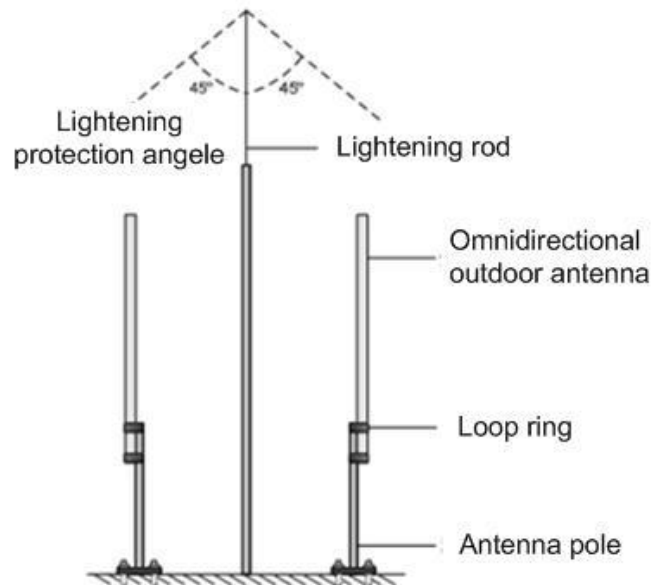

In case is impossible to install an independent lightning rod due to environmental limitations, the installation method shown in Figure 4-23 can be used. Be aware that the pole supporting the lightning rod should be kept at least 1m away from the omnidirectional outdoor antennas.

Figure 4-23 Omnidirectional Antenna Installation (2)

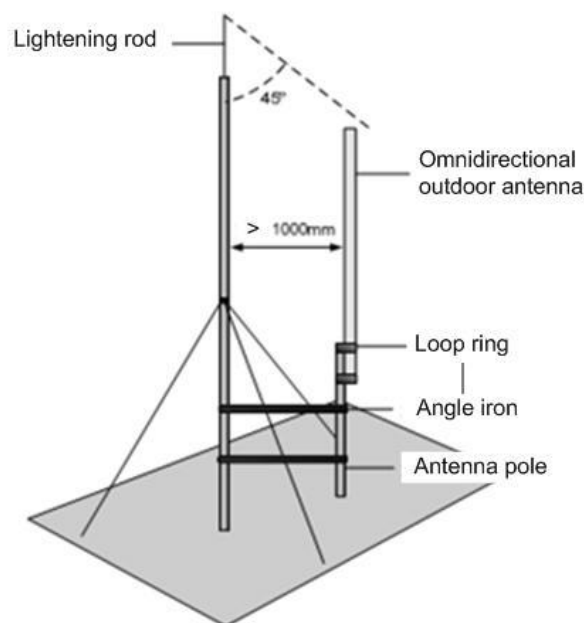

4.7.2 Install Directional Antennas

1. First, assemble the antennas, as shown in Figure 4-24.

Figure 4-24 Assembling Procedure of Directional Antennas



2. To install it on the iron tower, use a pulley to transport the antenna assembled to the platform on the iron tower, as shown in Figure 4-25. Following the safety rules when working at these heights.

Figure 4-25 Transportation the Antennas in the Height

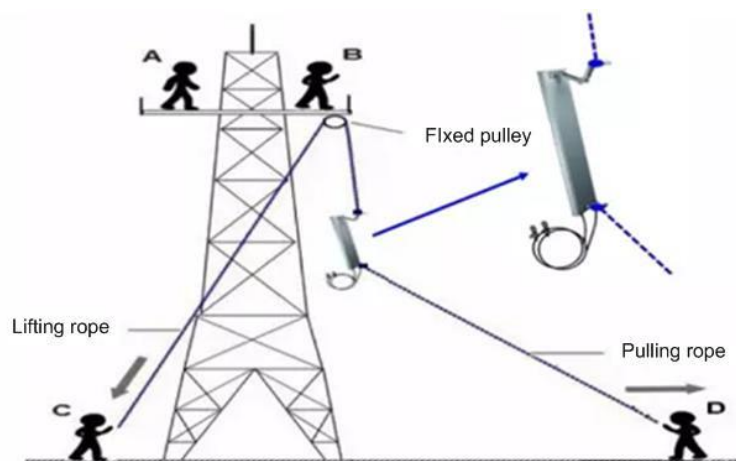

3. Fix the pole vertically to the ground or concrete pillars on the rooftop using expansion screws, and fasten it with steel wires. Then, mount the directional outdoor antenna onto the pole using the installation rack, as shown in Figure 4-26.

Figure 4-26 Directional Antenna Installation

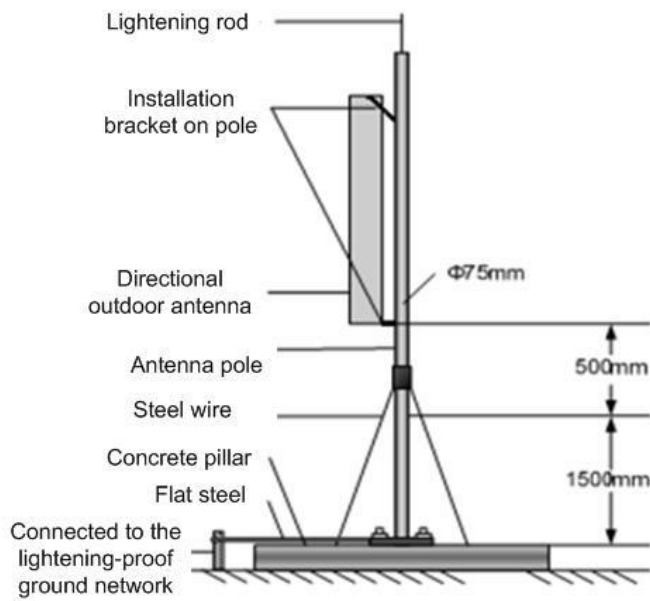

4. When the base station has been installed in a proper position, connect all the cables and wires.
5. Run tests, then seal and weatherproof all the connections after the testing has successfully completed. Refer to 3.5 Weatherproof Protection.

5. Power On

Power on the mBS1100, and the indicators will light up, as shown in Figure 5-1.

Figure 5-1 LED Indicators



The explanation of the indicator signal is given in Table 5-1.

Table 5-1 mBS1100 Indicator Description

Type	Color	Status	Meaning
PWR	Green	ON	Have power input
		OFF	No power input
RUN	Green	Fast blink: 0.125s on, 0.125s off	Single board loading
		Slow blink: 1s on, 1s OFF	Single board running well
		OFF	No power input, or single board failure
ALM	Red	ON	Hardware warning status, e.g., cable connection failure warning
		OFF	No warning
ACT	Green	ON	Active cell
		OFF	Inactive cell