

EM2148M

LTE Wireless Communication Module Specification

Introduction

Baicells is a private, high-tech company providing innovative LTE wireless broadband access solutions. The Baicells solutions support fixed wireless access and mobile scenarios. With the vision to connect the unconnected, Baicells has introduced breakthrough technologies to LTE, like moving a complete LTE system to special spectrum and building it with an IT based architecture.

With the Baicells turnkey end-to-end solutions, it becomes much easier to provide wireless internet within everyone's reach at a very low cost. These innovative solutions can be used by mobile operators, broadband access operators, Internet Service Providers (ISP), Mobile Virtual Network Operators (MVNO), governments, and enterprise private networks.

The Baicells EM2148M is a multimode wireless communication module with PCI Express ® Mini Card Electromechanical Specification, which can be applied in but not limited to equipment such as Tablet, Vehicle Mounted Terminals, CPE and electronic consumer products, and provides equipment with high-speed data access service in mobile environment (LTE TDD Band53).



The typical topology of EM2148M LTE Wireless Communication Module is as follows:

- Supports LTE-TDD frequency bands 53;
- Complies with 3GPP Release 9 CAT4 standards;
- Complies with PCI Express ®Mini Card Electromechanical Specification Revision 1.1(Note 1)/1.2/2.0.

Note 1: PCI Express ®Mini Card Electromechanical Specification Revision 1.1 is optional to Complied with by change BOM.

Basic Specifications

Item	Description
Dimensions	51mm x 30mm x 4.9mm
Card Type	Full-Mini Card (52Pin)
RF Connector	MHF I/MHFII
UE-Category	3GPP R9, CAT 4
USIM	1.8V/3.0V USIM
USB Version	USB 2.0 HIGH SPEED
Power Supply	3.3V ±9%
LED Indicators	SIM/PWR/LTE Signal
Weight	About 25g

LTE Specifications

Item	Description
LTE Mode	TDD
LTE Bands	B53 DL/UL : 2483.5MHz ~ 2495MHz
TXRX	1T2R
Peak Rate	<ul style="list-style-type: none"> • 10MHz: <ul style="list-style-type: none"> SA1: DL 40 Mbps, UL 6.8 Mbps SA2: DL 54 Mbps, UL 3.4 Mbps • 5MHz: <ul style="list-style-type: none"> SA1: DL 20 Mbps, UL 3.3 Mbps SA2: DL 27 Mbps, UL 1.6 Mbps
Channel Bandwidth	5MHz/10MHz
Modulation	UL: QPSK, 16QAM DL: QPSK, 16QAM, 64QAM
Receive Sensitivity	-95dBm @ QPSK, 10MHz, 25°C
MAX Output Power	22dBm (± 2)/TX ANT (Note 2)

Note 2: EIRP Limit is 36dBm, EIRP =Max Output Power+ Antenna Gain, Antenna Gain \leq 10dBi is recommended.

Environmental Specifications

Item	Description
Operating Temperature	-40°C to 45°C
Storage Temperature	-40°C to 70°C
Operating Humidity	5% to 95%

PIN Configuration Diagram

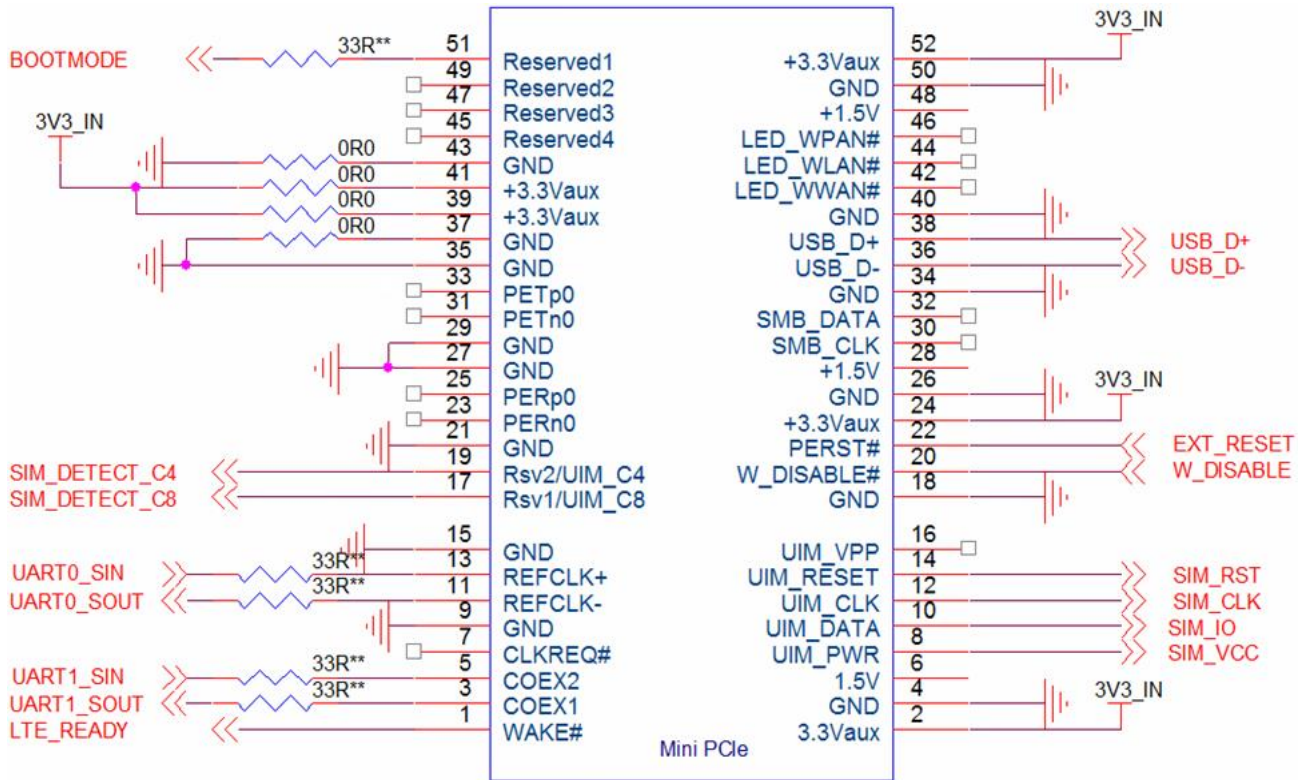

Pin	Standard Pin	Module Pin	Description	I/O	Remark
1	WAKE#	LTE_READY	Wake up the system host	DO	3.3V
2	3.3Vaux	3V3_IN	3.3V supply	DI	3.3V ± 9%
3	COEX1	NC	Optional: UART1_SOUT	DO	1.8V
4	GND	GND	Ground		Ground pin
5	COEX2	NC	Optional: UART1_SIN	DI	1.8V
6	1.5V	NC			
7	CLKREQ#	NC			

Pin	Standard Pin	Module Pin	Description	I/O	Remark
8	UIM_PWR	SIM_VCC	USIM card power supply	DO	3V/1.8V
9	GND	GND	Ground		Ground pin
10	UIM_DATA	SIM_IO	USIM card data signal	DI/DO	3V/1.8V
11	REFCLK-	NC	Optional:UART0_SO	DO	1.8V
12	UIM_CLK	SIM_CLK	USIM card clock signal	DO	3V/1.8V
13	REFCLK+	NC	Optional:UART0_SIN	DI	1.8V
14	UIM_RESET	SIM_RST	USIM card reset signal	DO	3V/1.8V
15	GND	GND	Ground		Ground pin
16	UIM_VPP	NC			
17	Reserved*(UIM_C8)	SIM_DETECT_C8		DI	
18	GND	GND	Ground		Ground pin
19	Reserved*(UIM_C4)	SIM_DETECT_C4		DI	
20	W_DISABLE#	W_DISABLE	Active low signal. This signal is Used by the system to disable radio operation on add-in cards that implement radio frequency applications.	DI	0:Active 1:3.3V

Pin	Standard Pin	Module Pin	Description	I/O	Remark
21	GND	GND	Ground		Ground pin
22	PERST#	EXT_RESET	Module resetting	DI	3.3V
23	PERn0	NC			
24	+3.3Vaux	3V3_IN	3.3V supply		3.3V ±9%
25	PERp0	NC			
26	GND	GND	Ground		Ground pin
27	GND	GND	Ground		Ground pin
28	+1.5V	NC			
29	GND	GND	Ground		Ground pin
30	SMB_CLK	NC			
31	PETn0	NC			
32	SMB_DATA	NC			
33	PETp0	NC			
34	GND	GND	Ground		Ground pin
35	GND	GND	Ground		Ground pin
36	USB_D-	USB_D-		DI/DO	

Pin	Standard Pin	Module Pin	Description	I/O	Remark
37	GND	GND	Optional: NC(Note 3)		PCI Express ®Mini Card Electromechanical Specification Revision 1.1: Reserved
38	USB_D+	USB_D+		DI/DO	
39	+3.3Vaux	3V3_IN	Optional: NC(Note 3)	DI	PCI Express ®Mini Card Electromechanical Specification Revision 1.1: Reserved
40	GND	GND	Ground		Ground pin
41	+3.3Vaux	3V3_IN	Optional: NC(Note 3)	DI	PCI Express ®Mini Card Electromechanical Specification Revision 1.1: Reserved
42	LED_WWAN#	NC			
43	GND	GND	Optional: NC(Note 3)		PCI Express ®Mini Card Electromechanical Specification Revision 1.1: Reserved
44	LED_WLAN#	NC			
45	Reserved	NC			
46	LED_WPAN#	NC			

Pin	Standard Pin	Module Pin	Description	I/O	Remark
47	Reserved	NC			
48	+1.5V	NC			
49	Reserved	NC			
50	GND	GND	Ground		Ground pin
51	Reserved	NC	Optional: Module Boot Mode selection(Note 3)	DI	0:boot in FFH mode 1:boot in FFF mode(default)
52	+3.3Vaux	3V3_IN	3.3V supply	DO	3.3V ±9%

Note 3: Optional setting: Supported by change BOM.

Model List

Models	Description
EM2148M	LTE Wireless Communication Module (LTE Wireless Communication Module, Mini-PCIE,TDD B53, CAT4, 1T2R)

Regulatory Compliance

FCC Compliance

This device complies with part 15 of the FCC Rules. Operation is subject to the following two conditions: (1) This device may not cause harmful interference, and (2) this device must accept any interference received, including interference that may cause undesired operation.

Any Changes or modifications not expressly approved by the party responsible for compliance could void the user's authority to operate the equipment.

This equipment has been tested and found to comply with the limits for a Class B digital device, pursuant to part 15 of the FCC Rules. These limits are designed to provide reasonable protection against harmful interference in a residential installation. This equipment generates uses and can radiate radio frequency energy and, if not installed and used in accordance with the instructions, may cause harmful interference to radio communications. However, there is no guarantee that interference will not occur in a particular installation. If this equipment does cause harmful interference to radio or television reception, which can be determined by turning the equipment off and on, the user is encouraged to try to correct the interference by one or more of the following measures:

- Reorient or relocate the receiving antenna.
- Increase the separation between the equipment and receiver.
- Connect the equipment into an outlet on a circuit different from that to which the receiver is connected.
- Consult the dealer or an experienced radio/TV technician for help.

FCC Radiation Exposure Statement

The modular can be installed or integrated in mobile or fix devices only. This modular cannot be installed in any portable device, for example, USB dongle like transmitters is forbidden.

This modular complies with FCC RF radiation exposure limits set forth for an uncontrolled environment. This transmitter must not be co-located or operating in conjunction with any other antenna or transmitter. The maximum allowable antenna gain is 10dBi. This modular must be installed and operated with a minimum distance of 20 cm between the radiator and user body. The allowed antenna type is external antenna.

If the FCC identification number is not visible when the module is installed inside another device, then the outside of the device into which the module is installed must also display a label referring to the enclosed module. This exterior label can use wording such as the following: "Contains Transmitter Module FCC ID: 2AG32EM2148M .

When the module is installed inside another device, the user manual of this device must contain below warning statements;

1. This device complies with Part 15 of the FCC Rules. Operation is subject to the following two conditions:

(1) This device may not cause harmful interference.

(2) This device must accept any interference received, including interference that may cause undesired operation.

2. Changes or modifications not expressly approved by the party responsible for compliance could void the user's authority to operate the equipment.

The devices must be installed and used in strict accordance with the manufacturer's instructions as described in the user documentation that comes with the product.

3. List of applicable FCC rules

This module has been tested and found to comply with part 25 requirements for Modular Approval.

The modular transmitter is only FCC authorized for the specific rule parts (i.e., FCC transmitter rules) listed on the grant, and that the host product manufacturer is responsible for compliance to any other FCC rules that apply to the host not covered by the modular transmitter grant of certification. If the grantee markets their product as being Part 15 Subpart B compliant (when it also contains unintentional-radiator digital circuitry), then the grantee shall provide a notice stating that the final host product still requires Part 15 Subpart B compliance testing with the modular transmitter installed.