

FCC REPORT

Applicant: Baicells Technologies Co., Ltd.

Address of Applicant: 3F, Hui Yuan Development Building, No.1 Shangdi Information Industry Base, Haidian Dist., Beijing, China

Equipment Under Test (EUT)

Product Name: LTE Outdoor CPE

Model No.: EG7035L-M2

Trade mark: BaiCells

FCC ID: 2AG32EG7035LM2

Applicable standards: FCC CFR Title 47 Part 2
FCC CFR Title 47 Part 90 Subpart Z

Date of sample receipt: 05 Jul., 2017

Date of Test: 05 Jul., 2017 to 11 Jul., 2017

Date of report issued: 11 Jul., 2017

Test Result: PASS*

* In the configuration tested, the EUT complied with the standards specified above.

Authorized Signature:



Bruce Zhang
Laboratory Manager

This report details the results of the testing carried out on one sample. The results contained in this test report do not relate to other samples of the same product and does not permit the use of the CCIS product certification mark. The manufacturer should ensure that all products in series production are in conformity with the product sample detailed in this report.

This report may only be reproduced and distributed in full. If the product in this report is used in any configuration other than that detailed in the report, the manufacturer must ensure the new system complies with all relevant standards.

This document cannot be reproduced except in full, without prior written approval of the Company. Any unauthorized alteration, forgery or falsification of the content or appearance of this document is unlawful and offenders may be prosecuted to the fullest extent of the law. Unless otherwise stated the results shown in this test report refer only to the sample(s) tested and such sample(s) are retained for 90 days only.

2. Version

Version No.	Date	Description
<i>00</i>	<i>11 Jul., 2017</i>	<i>Original</i>

Tested by:

Test Engineer**Date:***11 Jul., 2017*
_____**Reviewed by:**

Project Engineer**Date:***11 Jul., 2017*

3. Contents

	Page
1. COVER PAGE	1
2. VERSION	2
3. CONTENTS	3
4. TEST SUMMARY	4
5. GENERAL INFORMATION	5
5.1 CLIENT INFORMATION.....	5
5.2 GENERAL DESCRIPTION OF E.U.T.....	5
5.3 TEST MODES.....	6
5.4 DESCRIPTION OF SUPPORT UNITS.....	6
5.5 RELATED SUBMITTAL(S) / GRANT (S).....	6
5.6 TEST METHODOLOGY.....	6
5.7 LABORATORY FACILITY.....	6
5.8 LABORATORY LOCATION.....	6
5.9 TEST INSTRUMENTS LIST.....	7
6. SYSTEM TEST CONFIGURATION	8
6.1 EUT CONFIGURATION.....	8
6.2 EUT EXERCISE.....	8
6.3 CONFIGURATION OF TESTED SYSTEM.....	8
6.4 DESCRIPTION OF TEST MODES.....	8
6.5 TRANSMIT OUTPUT POWER AND PSD.....	9
6.6 OCCUPY BANDWIDTH.....	20
6.7 EMISSION MASK.....	26
6.8 OUT OF BAND EMISSION AT ANTENNA TERMINALS.....	31
6.9 FIELD STRENGTH OF SPURIOUS RADIATION MEASUREMENT.....	48
6.10 FREQUENCY STABILITY V.S. TEMPERATURE MEASUREMENT.....	52
6.11 FREQUENCY STABILITY V.S. VOLTAGE MEASUREMENT.....	57
7 TEST SETUP PHOTO	60
8 EUT CONSTRUCTIONAL DETAILS	61

4. Test Summary

Test Item	Section in CFR 47	Result
	FCC	
RF Output Power	Part 2.1046 Part 90.1321	Pass
Modulation Characteristics	Part 2.1047	Pass
99% & -26 dB Occupied Bandwidth	Part 2.1049 Part 90.209	Pass
Emission Mask	Part 90.210(b)	Pass
Spurious Emissions at Antenna Terminal	Part 2.1051 Part 90.1323	Pass
Field Strength of Spurious Radiation	Part 2.1053 Part 90.1323	Pass
Frequency stability vs. temperature	Part 2.1055(a)(1)(b) Part 90.213(a)	Pass
Frequency stability vs. voltage	Part 2.1055(d)(1)(2) Part 90.213(a)	Pass

Pass: The EUT complies with the essential requirements in the standard.

5. General Information

5.1 Client Information

Applicant:	Baicells Technologies Co., Ltd.
Address of Applicant:	3F, Hui Yuan Development Building, No.1 Shangdi Information Industry Base, Haidian Dist., Beijing, China
Manufacturer	Baicells Technologies Co., Ltd.
Address of Manufacturer:	3F, Hui Yuan Development Building, No.1 Shangdi Information Industry Base, Haidian Dist., Beijing, China

5.2 General Description of E.U.T.

Product Name:	LTE Outdoor CPE
Model No.:	EG7035L-M2
Operation Frequency range:	Band43: 3650MHz~3700MHz
Modulation type:	BPSK, QPSK, 16QAM
Antenna type:	Internal antenna ("N" type)
Antenna gain:	10 dBi
AC adapter:	Model: G0549A-240-050 Input: AC100-240V 50/60Hz 0.5 A Output: DC 24V, 500 mA
Power supply:	DC 24V

Test Channel:

Band43

5MHz		10MHz	
Channel:	Frequency (MHz)	Channel:	Frequency (MHz)
Lowest	3652.5	Lowest	3655.0
Middle	3675.0	Middle	3675.0
Highest	3697.5	Highest	3695.0
15MHz		20MHz	
Channel:	Frequency (MHz)	Channel:	Frequency (MHz)
Lowest	3657.5	Lowest	3660.0
Middle	3675.0	Middle	3675.0
Highest	3692.5	Highest	3690.0

5.3 Test modes

Data mode (QPSK)	Keep the EUT in data communicating mode (QPSK). (5MHz, 10MHz, 15MHz, 20MHz)
Data mode (16QAM)	Keep the EUT in data communicating mode (16QAM). (5MHz, 10MHz, 15MHz, 20MHz)

5.4 Description of Support Units

Manufacturer	Description	Model	Serial Number	FCC ID/DoC
/	/	/	/	/

5.5 Related Submittal(s) / Grant (s)

FCC: This submittal(s) (test report) is filing to comply with Section Part 90 subpart Z of the FCC CFR 47 Rules.

5.6 Test Methodology

FCC: Both conducted and radiated testing were performed according to the procedures document on TIA/EIA 603 and FCC CFR 47.1046, 2.1047, 2.1049, 2.1051, 2.1053, 2.1055 and 2.1057

5.7 Laboratory Facility

The test facility is recognized, certified, or accredited by the following organizations:

- FCC - Registration No.: 817957**
 Shenzhen Zhongjian Nanfang Testing Co., Ltd. EMC Laboratory has been registered and fully described in a report filed with the (FCC) Federal Communications Commission. The acceptance letter from the FCC is maintained in out files. Registration 817957, February 27, 2012.
- IC - Registration No.: 10106A-1**
 The 3m Semi-anechoic chamber of Shenzhen Zhongjian Nanfang Testing Co., Ltd. has been Registered by Certification and Engineering Bureau of Industry Canada for radio equipment testing with Registration No.: 10106A-1.
- CNAS - Registration No.: CNAS L6048**
 Shenzhen Zhongjian Nanfang Testing Co., Ltd. is accredited to ISO/IEC 17025:2005 General Requirements for the Competence of Testing and Calibration laboratories for the competence of testing. The Registration No. is CNAS L6048.

5.8 Laboratory Location

Shenzhen Zhongjian Nanfang Testing Co., Ltd.
 Address: No.B-C, 1/F., Building 2, Laodong No.2 Industrial Park, Xixiang Road,
 Bao'an District, Shenzhen, Guangdong, China
 Tel: +86-755-23118282
 Fax: +86-755-23116366
 Email: info@ccis-cb.com

5.9 Test Instruments list

Test Equipment	Manufacturer	Model No.	Inventory No.	Cal. Date (mm-dd-yy)	Cal. Due date (mm-dd-yy)
3m SAC	SAEMC	9(L)*6(W)* 6(H)	CCIS0001	08-23-2014	08-22-2017
BiConiLog Antenna	SCHWARZBECK	VULB9163	CCIS0005	02-25-2017	02-24-2018
Horn Antenna	SCHWARZBECK	BBHA9120D	CCIS0006	02-25-2017	02-24-2018
Pre-amplifier (10kHz-1.3GHz)	HP	8447D	CCIS0003	02-25-2017	02-24-2018
Pre-amplifier (1GHz-18GHz)	Compliance Direction Systems Inc.	PAP-1G18	CCIS0011	02-25-2017	02-24-2018
Pre-amplifier (18-26GHz)	Rohde & Schwarz	AFS33-18002 650-30-8P-44	GTS218	02-25-2017	02-24-2018
Horn Antenna	ETS-LINDGREN	3160	GTS217	02-25-2017	02-24-2018
Spectrum analyzer 9k-30GHz	Rohde & Schwarz	FSP30	CCIS0023	02-25-2017	02-24-2018
Spectrum Analyzer 20Hz-26.5GHz	Agilent	N9020A	MY50510123	02-25-2017	02-24-2018
EMI Test Receiver	Rohde & Schwarz	ESRP7	CCIS0167	02-25-2017	02-24-2018
Loop antenna	Laplace instrument	RF300	EMC0701	02-25-2017	02-24-2018
Coaxial Cable	CCIS	N/A	CCIS0016	02-25-2017	02-24-2018
Coaxial Cable	CCIS	N/A	CCIS0017	02-25-2017	02-24-2018
Coaxial cable	CCIS	N/A	CCIS0018	02-25-2017	02-24-2018
Coaxial Cable	CCIS	N/A	CCIS0019	02-25-2017	02-24-2018
Coaxial Cable	CCIS	N/A	CCIS0087	02-25-2017	02-24-2018
Signal Generator	Rohde & Schwarz	SMR 20	CCIS0024	02-25-2017	02-24-2018
Signal Generator	Rohde & Schwarz	SMX	CCIS0064	02-25-2017	02-24-2018
Signal Analyzer	Rohde & Schwarz	FSIQ3	CCIS0088	02-25-2017	02-24-2018

6. System test configuration

6.1 EUT Configuration

The EUT configuration for testing is installed on RF field strength measurement to meet the commission's requirement and operating in a manner which intends to maximize its emission characteristics in a continuous normal application.

6.2 EUT Exercise

The EUT (Transmitter) was operated in the engineering mode to fix the Tx frequency which was for the purpose of the measurements.

6.3 Configuration of Tested System

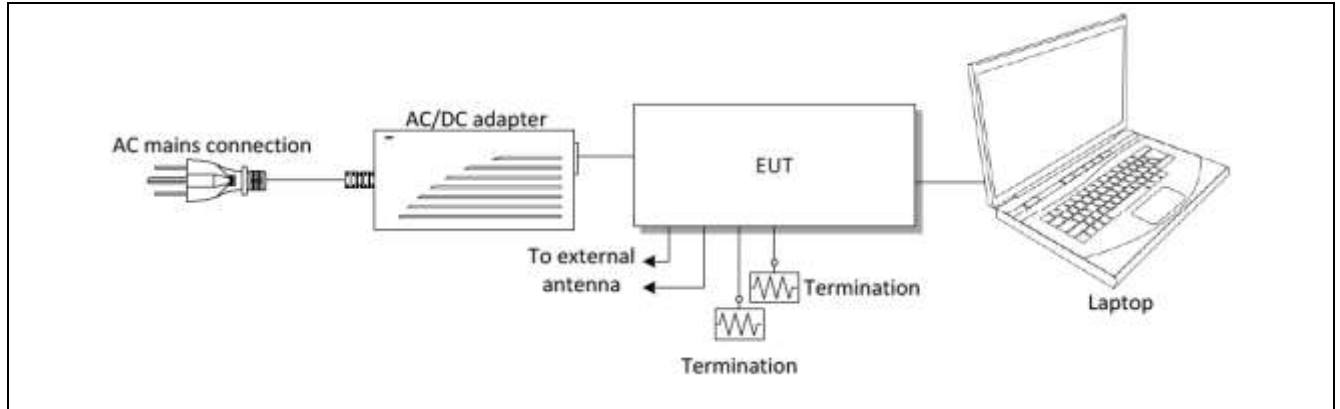

6.4 Description of Test Modes

The EUT has been tested under operating condition. EUT staying in continuous transmitting mode. Channel Low, Mid and High for each type band with rated data rate were chosen for full testing. The field strength of spurious radiation emission was measured as EUT stand-up position (H mode) and lie down position (E1, E2 mode) for three modes with power adaptor, earphone and Data cable. The worst-case H mode.

6.5 Transmit Output Power and PSD

Test Requirement:	FCC part90.1321(a)
Test Method:	FCC part2.1046 and KDB 971168 D01
Limit:	<p>FCC:</p> <p>(a) Base and fixed stations are limited to 25 watts/25 MHz equivalent isotropically radiated power (EIRP). In any event, the peak EIRP powerdensity shall not exceed 1 Watt in any one-megahertz slice of spectrum.</p> <p>(b) In addition to the provisions in paragraph (a) of this section, transmitters operating in the 3650-3700 MHz band that emit multipliedirectional beams, simultaneously or sequentially, for the purpose of directing signals to individual receivers or to groups of receivers provided theemissions comply with the following:</p> <p>(1) Different information must be transmitted to each receiver.</p> <p>(2) If the transmitter employs an antenna system that emits multiple directional beams but does not emit multiple directional beamssimultaneously, the total output power conducted to the array or arrays that comprise the device, <i>i.e.</i>, the sum of the power supplied to allantennas, antenna elements, staves, etc. and summed across all carriers or frequency channels, shall not exceed the limit specified in paragraph(a) of this section, as applicable. The directional antenna gain shall be computed as follows:</p> <p>(i) The directional gain, in dBi, shall be calculated as the sum of 10 log (number of array elements or staves) plus the directional gain, in dBi,of the individual element or stave having the highest gain.</p> <p>(ii) A lower value for the directional gain than that calculated in paragraph (b)(2)(i) of this section will be accepted if sufficient evidence ispresented, <i>e.g.</i>, due to shading of the array or coherence loss in the beam-forming.</p> <p>(3) If a transmitter employs an antenna that operates simultaneously on multiple directional beams using the same or different frequencychannels and if transmitted beams overlap, the power shall be reduced to ensure that the aggregate power from the overlapping beams does notexceed the limit specified in paragraph (b)(2) of this section. In addition, the aggregate power transmitted simultaneously on all beams shall notexceed the limit specified in paragraph (b)(2) of this section by more than 8 dB.</p> <p>(4) Transmitters that emit a single directional beam shall operate under the provisions of paragraph (b)(2) of this section.</p>
Test Procedure:	RBW=1MHz, VBW=3MHz, Detector mode= RMS , Trace mode: Power averaging over 100 sweeps
Test Instruments:	Refer to section 5.8 for details
Test mode:	Refer to section 5.3 for details
Test results:	Passed

Measurement Data

Band43 Power:

Modulation	Frequency (MHz)	Output Power (dBm)	Antenna gain (dBi)	EIRP (dBm)	Limited (dBm)
QPSK(5MHz)	3652.50	24.90	10	34.90	37.01
	3675.00	25.08	10	35.08	
	3697.50	24.31	10	34.31	
16QAM(5MHz)	3652.50	25.21	10	35.21	
	3675.00	25.16	10	35.16	
	3697.50	24.42	10	34.42	
QPSK(10MHz)	3655.00	25.13	10	35.13	40.02
	3675.00	24.97	10	34.97	
	3695.00	24.82	10	34.82	
16QAM(10MHz)	3655.00	25.32	10	35.32	
	3675.00	25.42	10	35.42	
	3695.00	24.99	10	34.99	
QPSK(15MHz)	3657.50	24.58	10	34.58	41.78
	3675.00	24.74	10	34.74	
	3692.50	24.40	10	34.40	
16QAM(15MHz)	3657.50	25.11	10	35.11	
	3675.00	24.87	10	34.87	
	3692.50	24.44	10	34.44	
QPSK(20MHz)	3660.00	24.54	10	34.54	43.03
	3675.00	24.16	10	34.16	
	3690.00	24.16	10	34.16	
16QAM(20MHz)	3660.00	24.80	10	34.80	
	3675.00	24.60	10	34.60	
	3690.00	24.30	10	34.30	

Note: Limit=44dBm+10log(bandwidth/25MHz)

Test plot as below:

5MHz

QPSK

16QAM

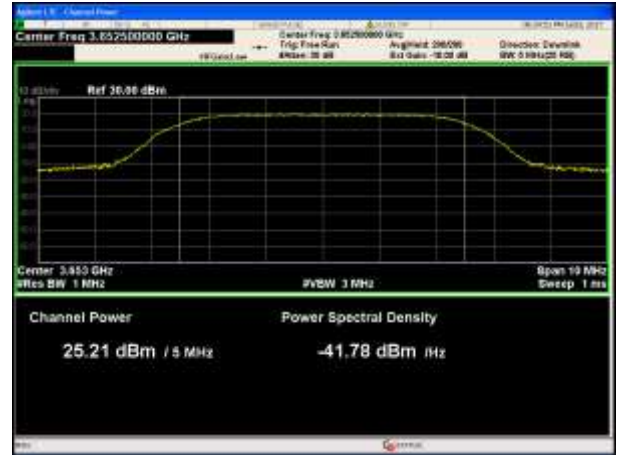
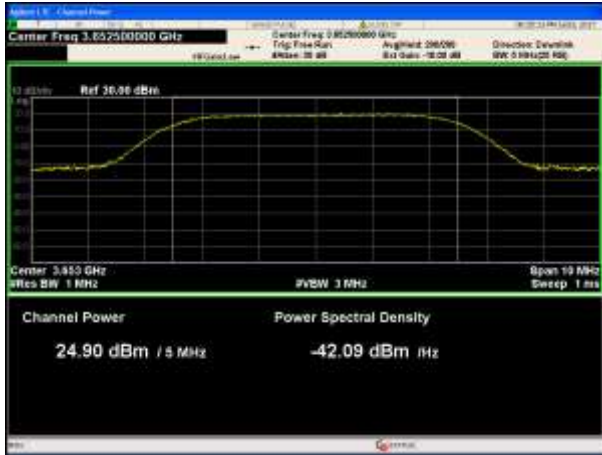

Lowest channel

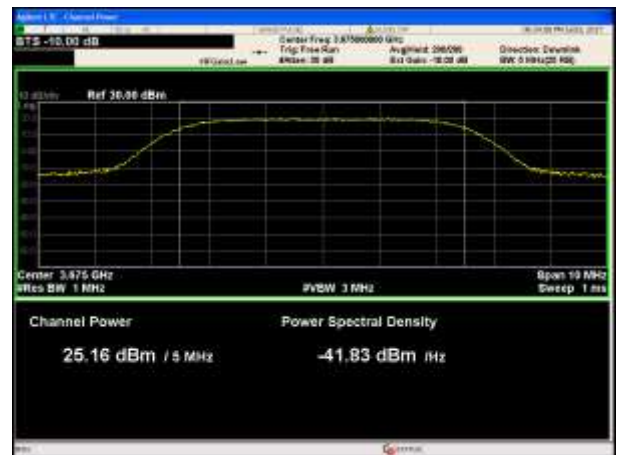
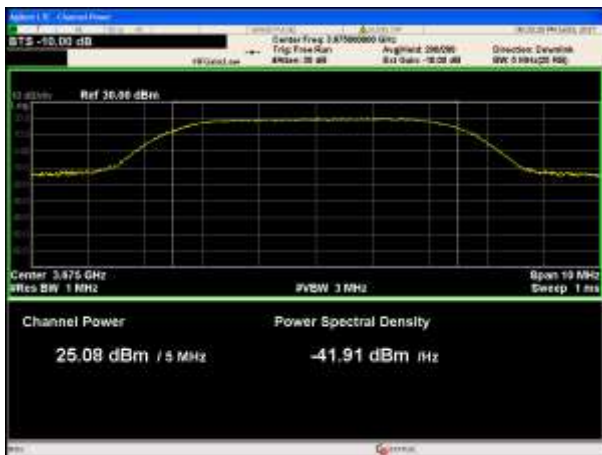

Middle channel

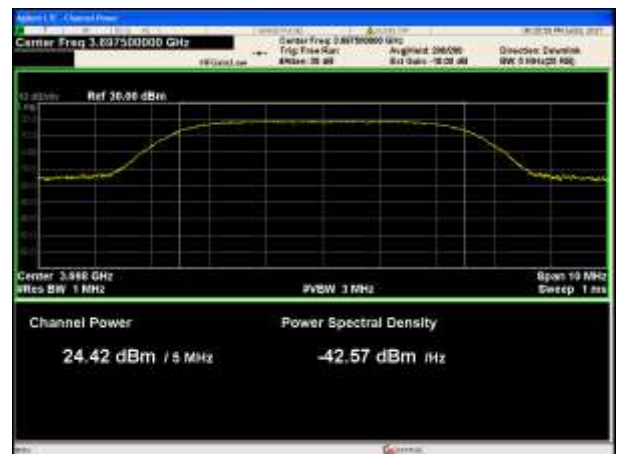
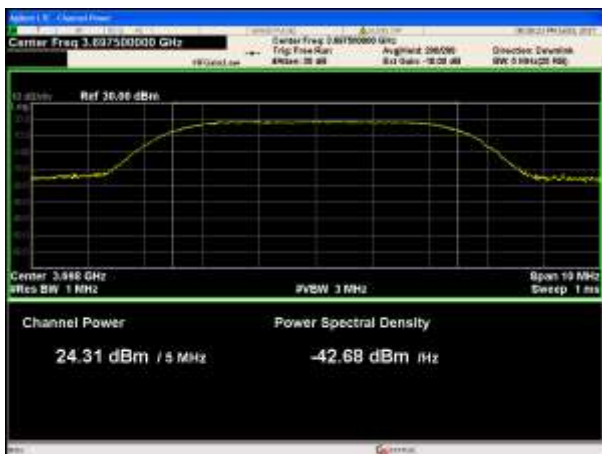

Highest channel

10MHz

QPSK

16QAM

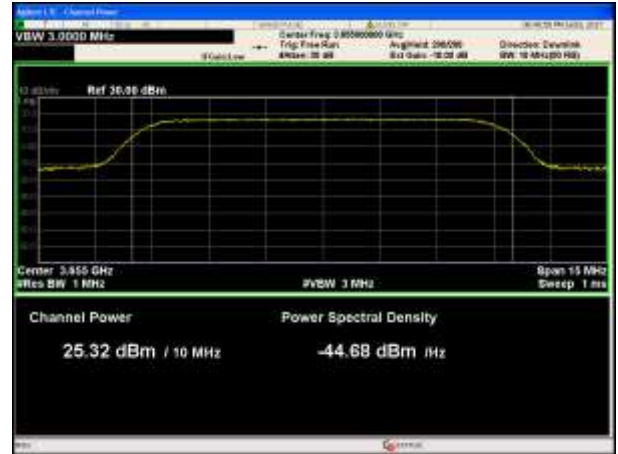
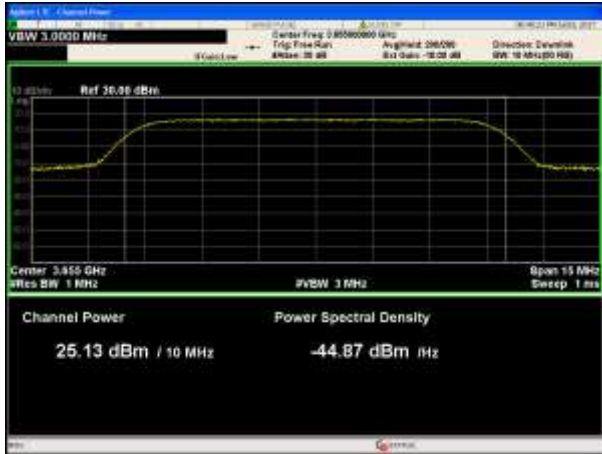

Lowest channel

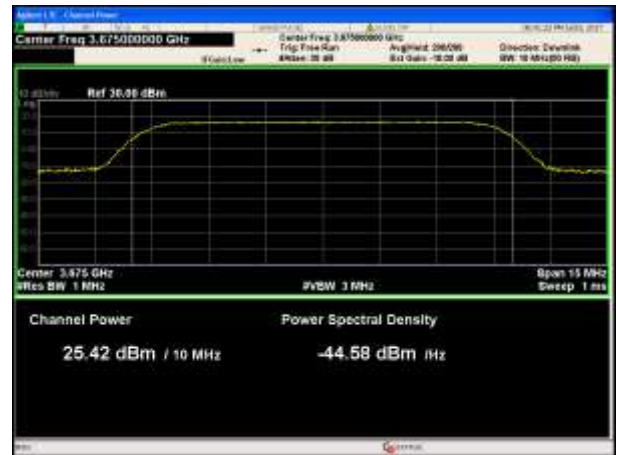
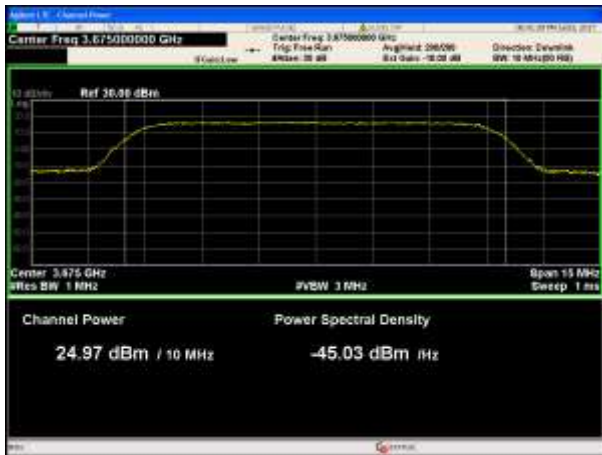

Middle channel

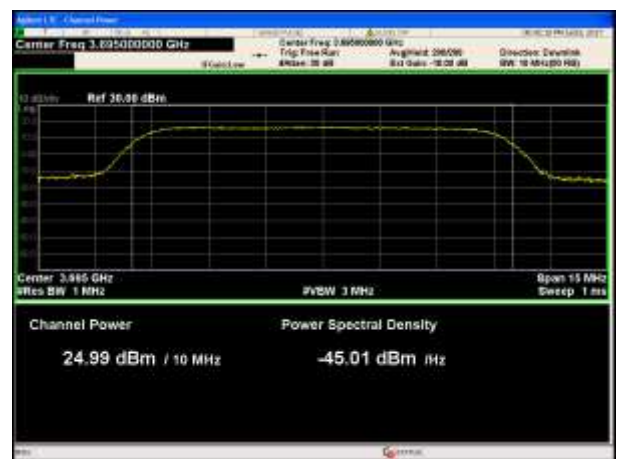
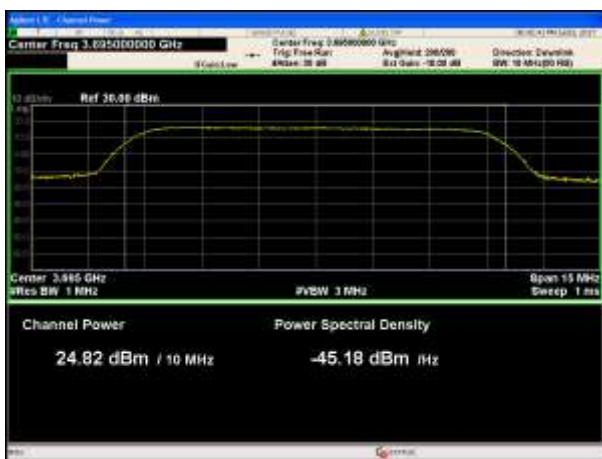

Highest channel

15MHz

QPSK

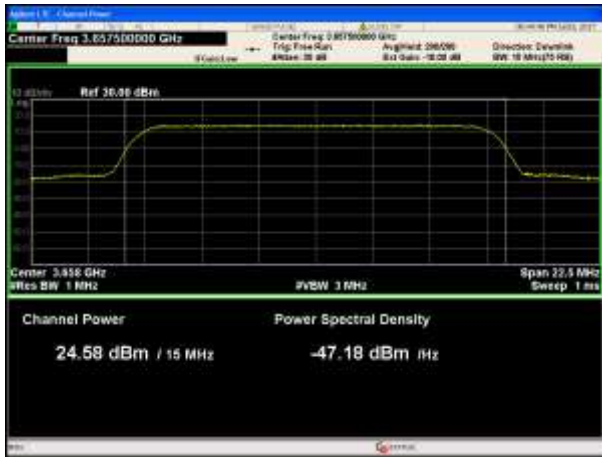

16QAM

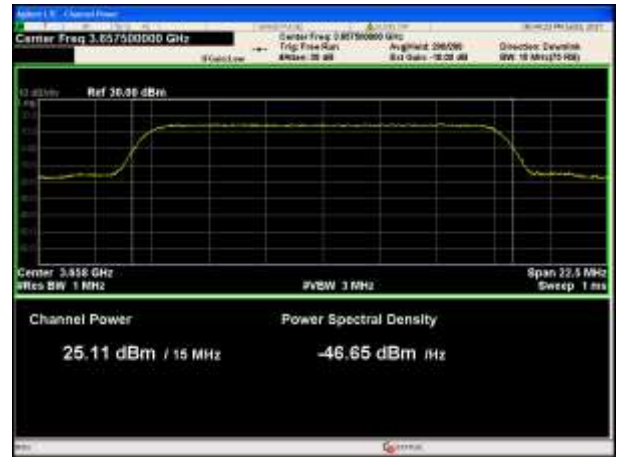

Lowest channel

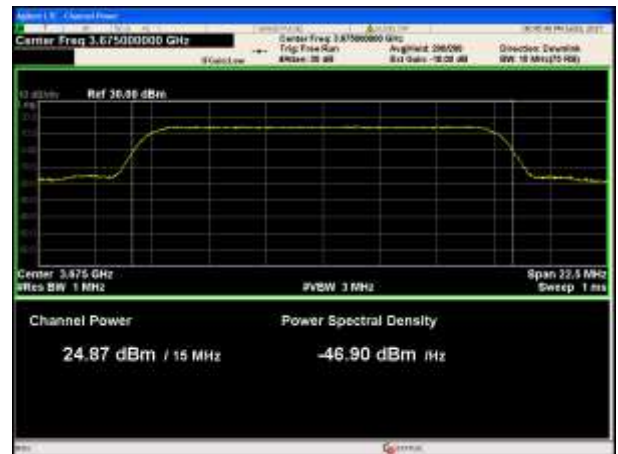
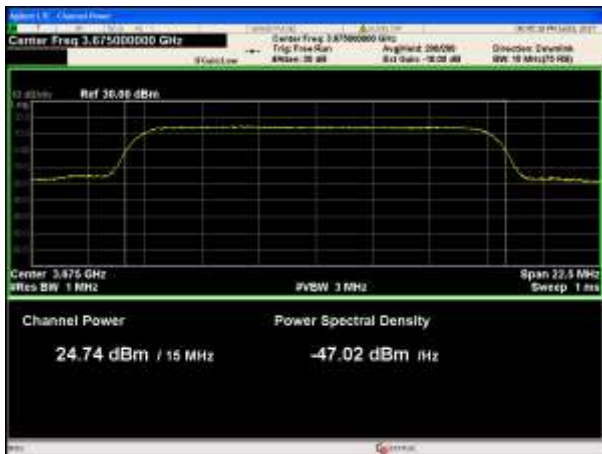

Middle channel

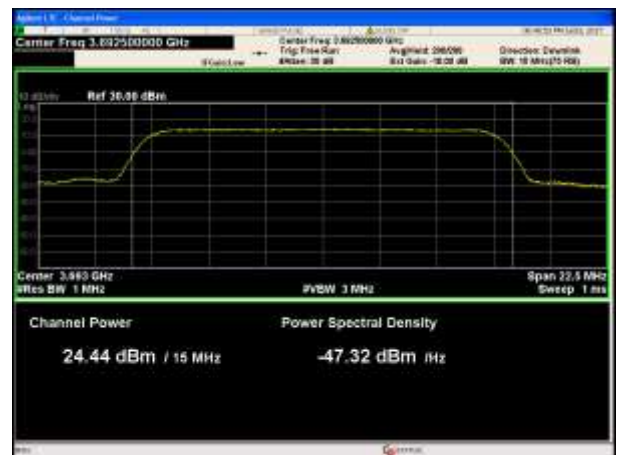
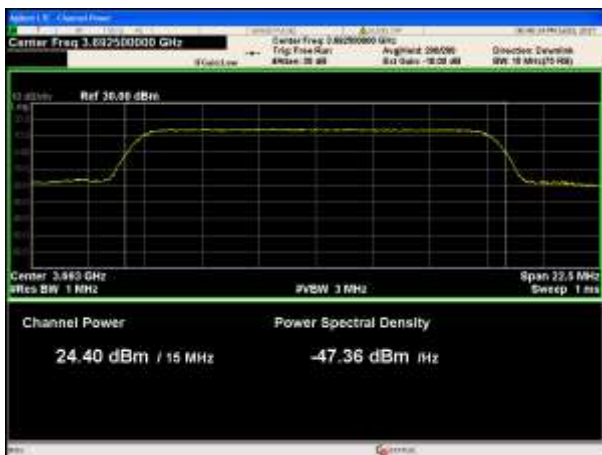

Highest channel

20MHz

QPSK

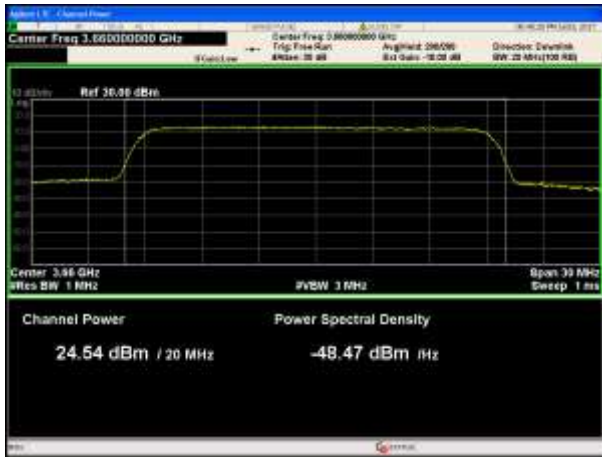

16QAM

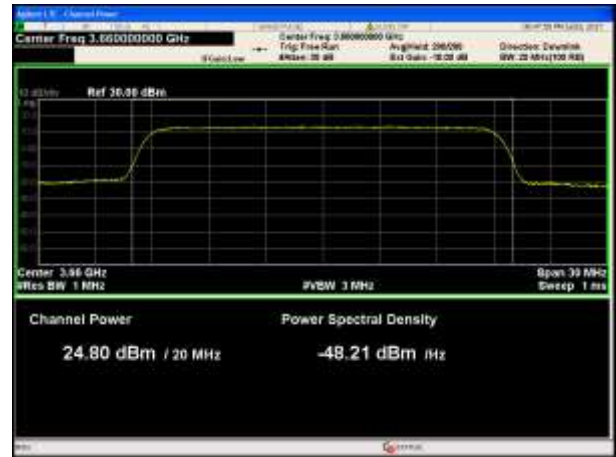

Lowest channel

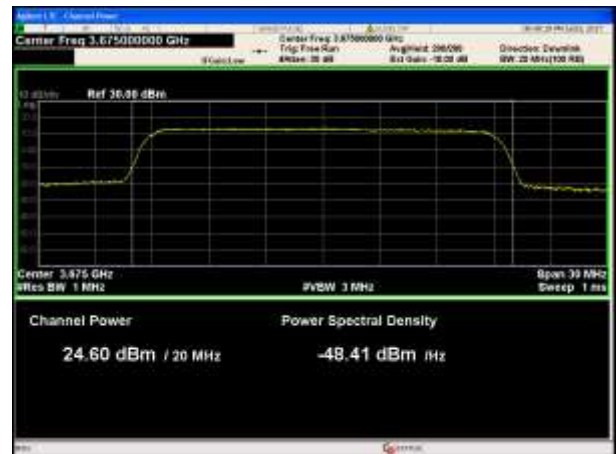
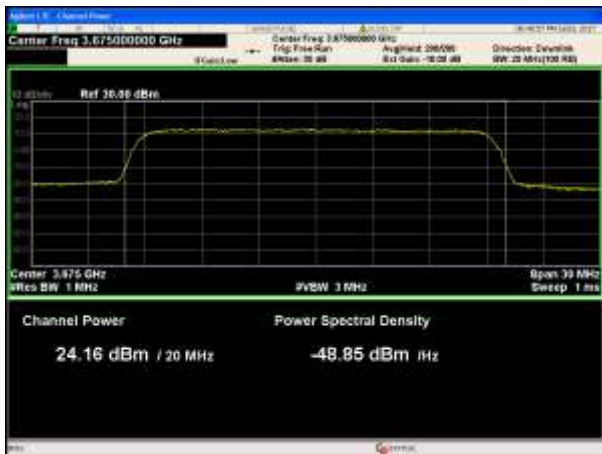

Middle channel

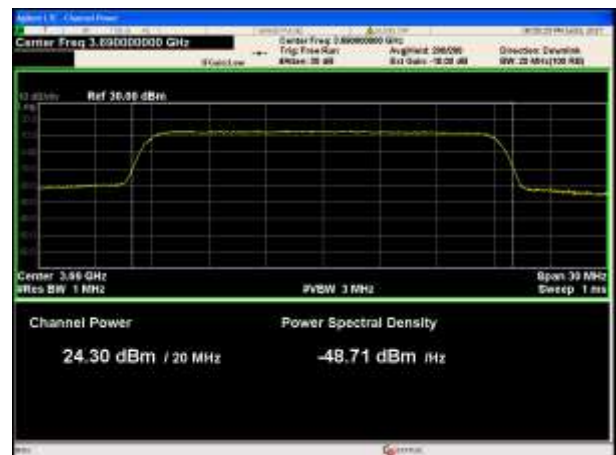
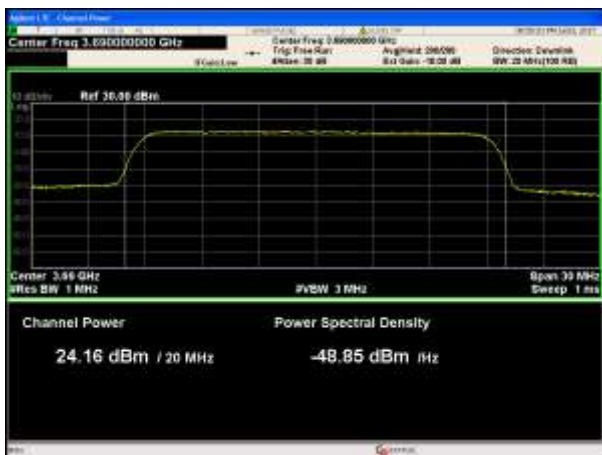

Highest channel

Band43 PSD:

Modulation	Frequency (MHz)	Output Power (dBm)	Antenna gain (dBi)	PSD (dBm)	Limited (dBm)
QPSK(5MHz)	3652.50	18.86	10	28.86	30
	3675.00	18.99	10	28.99	30
	3697.50	19.00	10	29.00	30
16QAM(5MHz)	3652.50	18.93	10	28.93	30
	3675.00	18.96	10	28.96	30
	3697.50	18.92	10	28.92	30
QPSK(10MHz)	3655.00	18.09	10	28.09	30
	3675.00	18.58	10	28.58	30
	3695.00	17.18	10	27.18	30
16QAM(10MHz)	3655.00	18.23	10	28.23	30
	3675.00	18.03	10	28.03	30
	3695.00	17.57	10	27.57	30
QPSK(15MHz)	3657.50	15.65	10	25.65	30
	3675.00	15.37	10	25.37	30
	3692.50	15.77	10	25.77	30
16QAM(15MHz)	3657.50	16.72	10	26.72	30
	3675.00	15.78	10	25.78	30
	3692.50	15.68	10	25.68	30
QPSK(20MHz)	3660.00	13.65	10	23.65	30
	3675.00	14.19	10	24.19	30
	3690.00	14.53	10	24.53	30
16QAM(20MHz)	3660.00	14.43	10	24.43	30
	3675.00	13.99	10	23.99	30
	3690.00	14.55	10	24.55	30

Test plot as below:

5MHz

QPSK

16QAM



Lowest channel



Middle channel

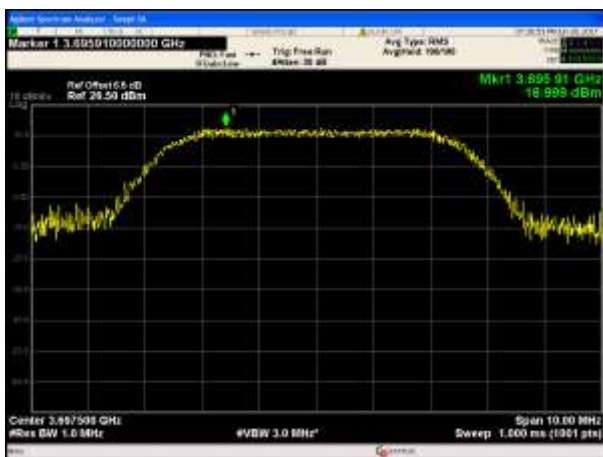

Highest channel

10MHz

QPSK

16QAM



Lowest channel



Middle channel

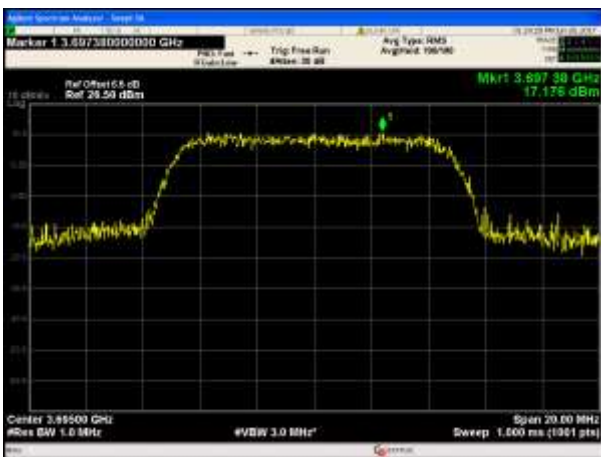

Highest channel

15MHz

QPSK



16QAM



Lowest channel

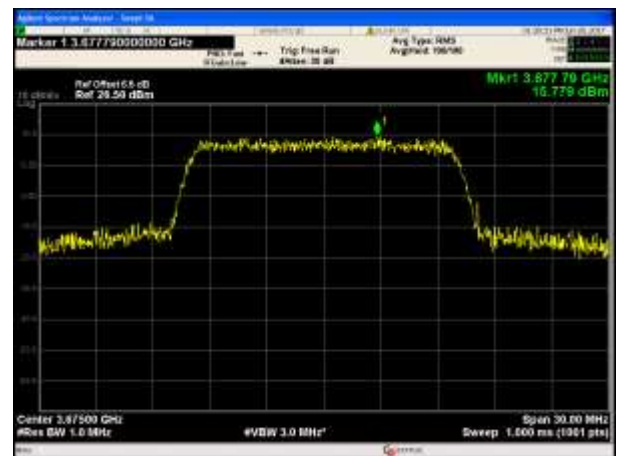

Middle channel

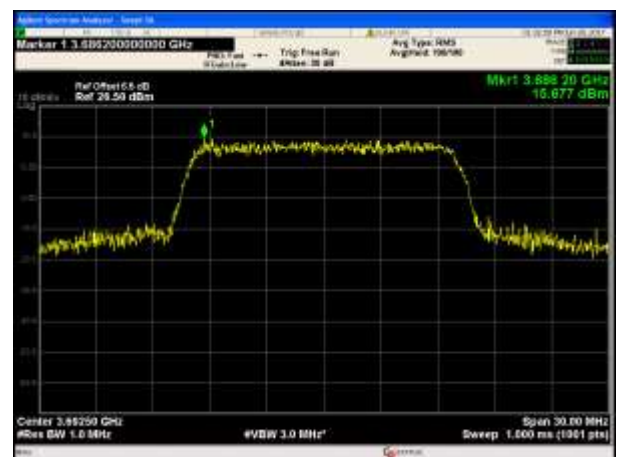
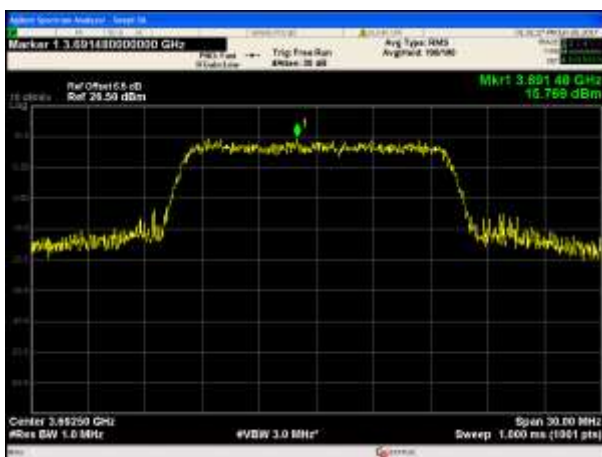

Highest channel

20MHz

QPSK

16QAM



Lowest channel



Middle channel

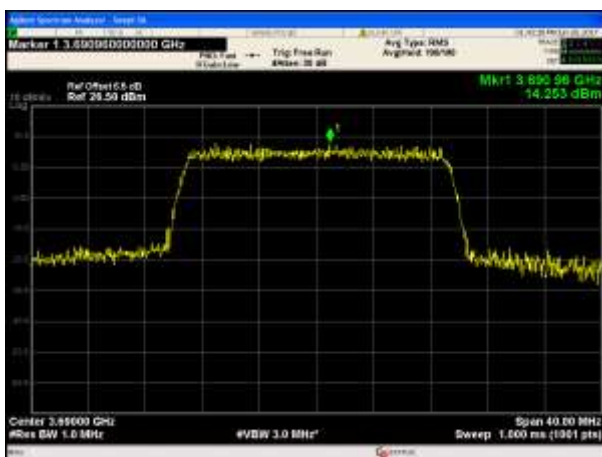

Highest channel

6.6 Occupy Bandwidth

Test Requirement:	FCC part 90.209
Test Method:	FCC part 2.1049 and KDB 971168 D01
Test Procedure:	<ol style="list-style-type: none"> 1. The EUT's output RF connector was connected with a short cable to the spectrum analyzer 2. The transmitter shall be operated at its maximum carrier power measured under normal test conditions. 3. The span of the analyzer shall be set to capture all products of the modulation process, including the emission skirts. 4. The resolution bandwidth (RBW) shall be in the range of 1% to 5% of the occupied bandwidth (OBW) and video bandwidth (VBW) shall be approximately 3x RBW.
Test Instruments:	Refer to section 5.8 for details
Test mode:	Refer to section 5.3 for details
Test results:	Passed

Measurement Data

Bandwidth(MHz)	Modulation	Test Channel	99% Occupy bandwidth (MHz)
5	QPSK	Lowest	4.5090
		Middle	4.5018
		Highest	4.4917
	16QAM	Lowest	4.5016
		Middle	4.5173
		Highest	4.5070
10	QPSK	Lowest	9.0167
		Middle	9.0449
		Highest	9.0397
	16QAM	Lowest	9.0504
		Middle	9.0495
		Highest	9.0520
15	QPSK	Lowest	13.500
		Middle	13.472
		Highest	13.465
	16QAM	Lowest	13.480
		Middle	13.471
		Highest	13.491
20	QPSK	Lowest	17.909
		Middle	17.905
		Highest	17.931
	16QAM	Lowest	17.897
		Middle	17.879
		Highest	17.873

Test plot as follows:

5MHz

QPSK

16QAM



Lowest channel



Middle channel

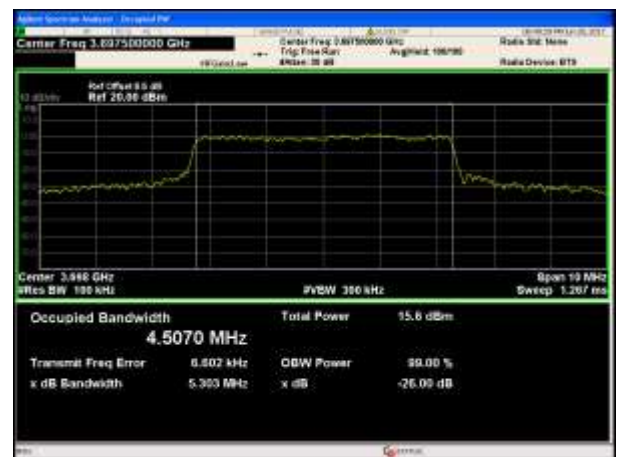

Highest channel

10MHz

QPSK

16QAM

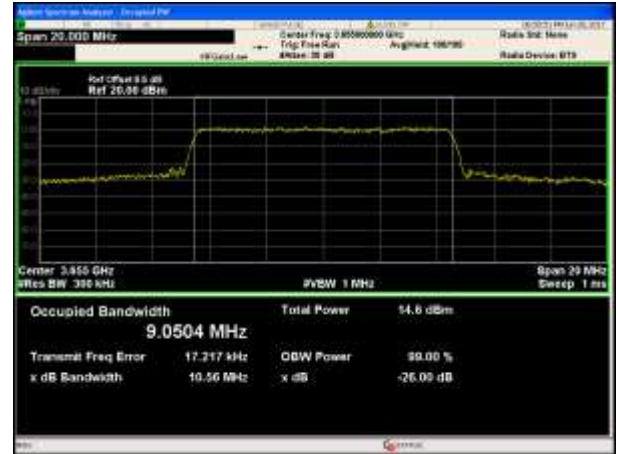

Lowest channel

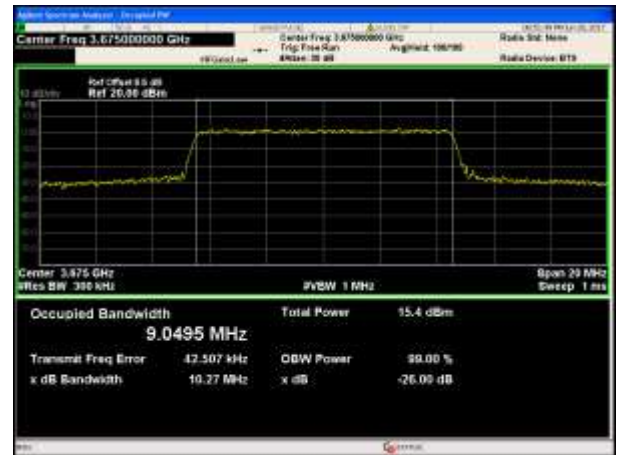
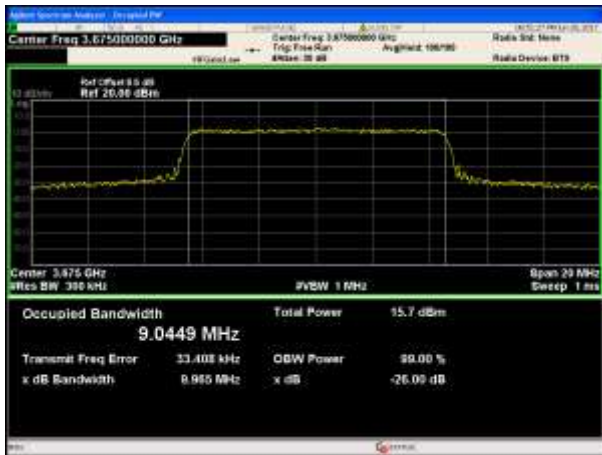

Middle channel



Highest channel

15MHz

QPSK

16QAM

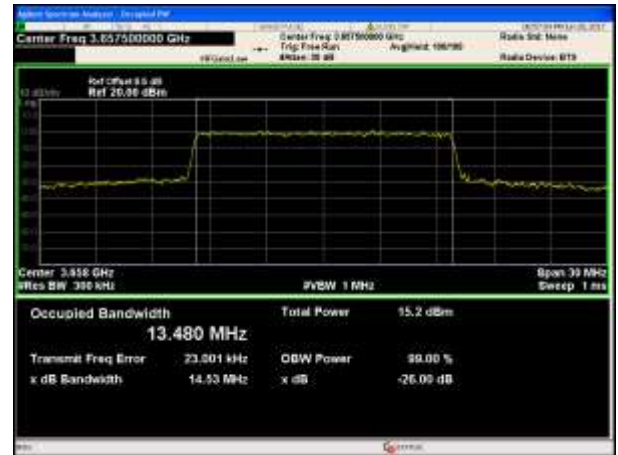
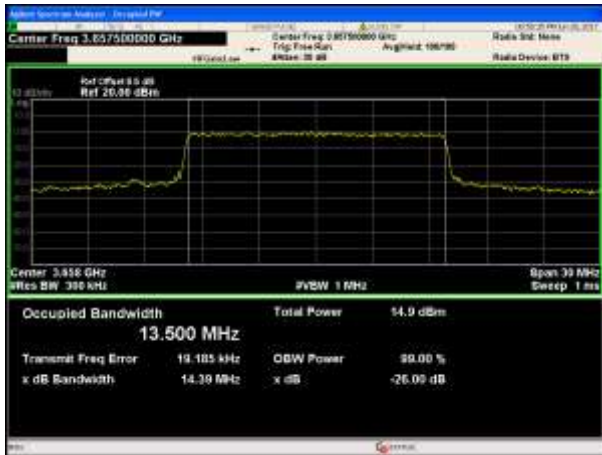

Lowest channel

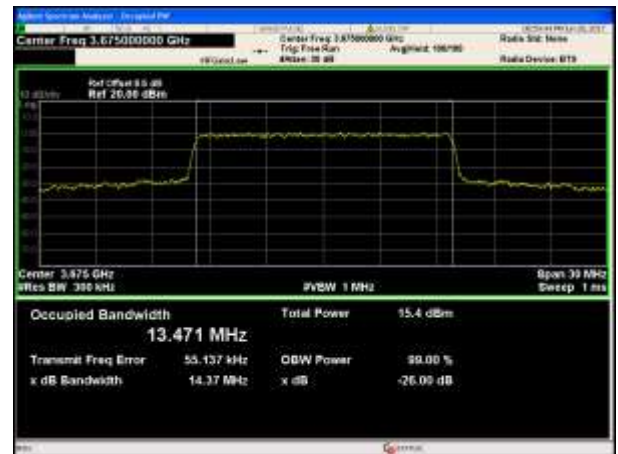

Middle channel

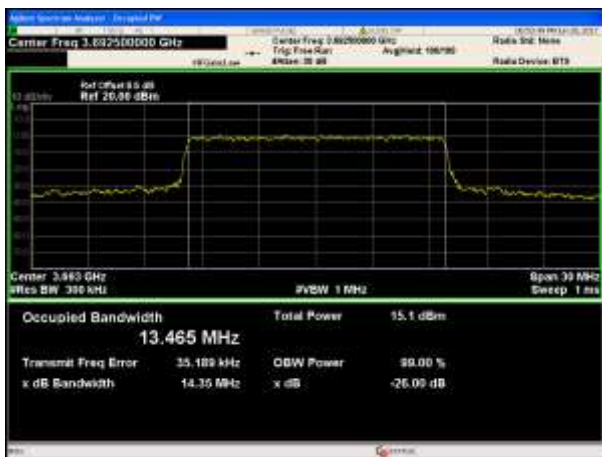

Highest channel

20MHz

QPSK

16QAM

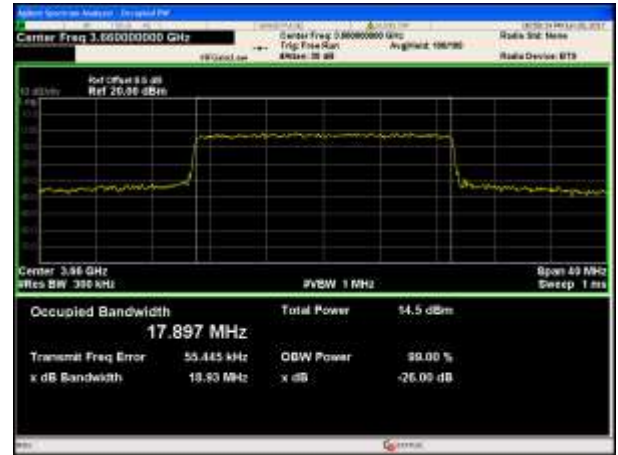
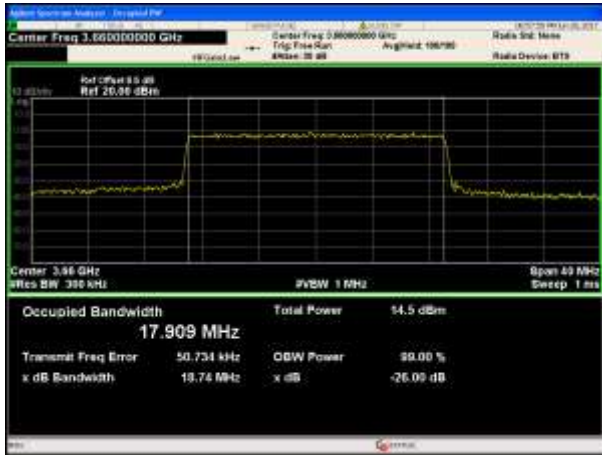

Lowest channel

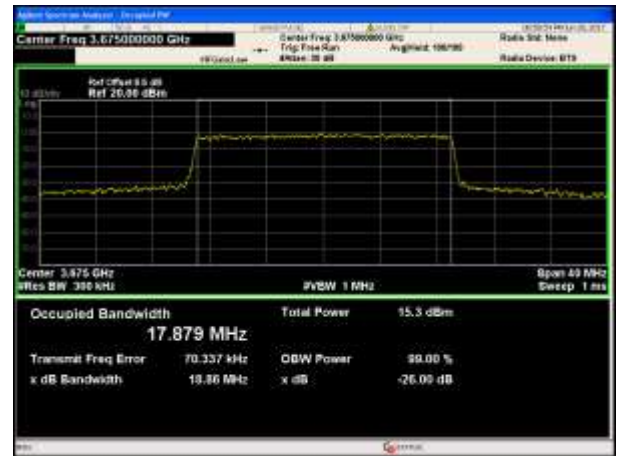
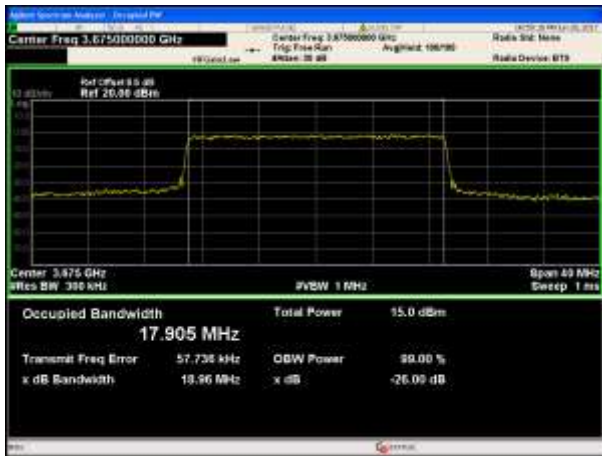

Middle channel

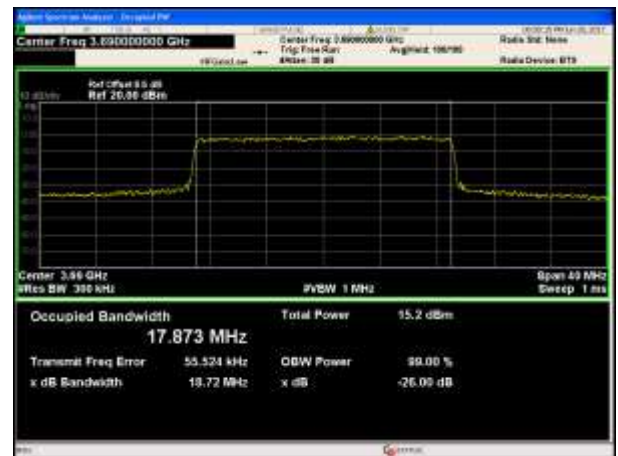

Highest channel

6.7 Emission Mask

Test Requirement:	FCC part 90.210(b)
Test Method	KDB 971168 D01
Limit:	<p>Emission Mask B. For transmitters that are equipped with an audio low-pass filter, the power of any emission must be attenuated below the unmodulated carrier power (P) as follows:</p> <p>(1) On any frequency removed from the assigned frequency by more than 50 percent, but not more than 100 percent of the authorized bandwidth: At least 25 dB.</p> <p>(2) On any frequency removed from the assigned frequency by more than 100 percent, but not more than 250 percent of the authorized bandwidth: At least 35 dB.</p> <p>(3) On any frequency removed from the assigned frequency by more than 250 percent of the authorized bandwidth: At least 43 + 10 log (P) dB.</p>
Test Procedure:	<ol style="list-style-type: none"> The RF output of the transceiver was connected to a spectrum analyzer through appropriate attenuation. RBW=100kHz, VBW=1MHz, Detector mode= RMS, Trace mode: Power averaging over 100 sweeps
Test Instruments:	Refer to section 5.8 for details
Test mode:	Refer to section 5.3 for details
Test results:	PASS

Measurement Data:
 Test plots as below:
 Chain 0:

5MHz

QPKS

64QAM

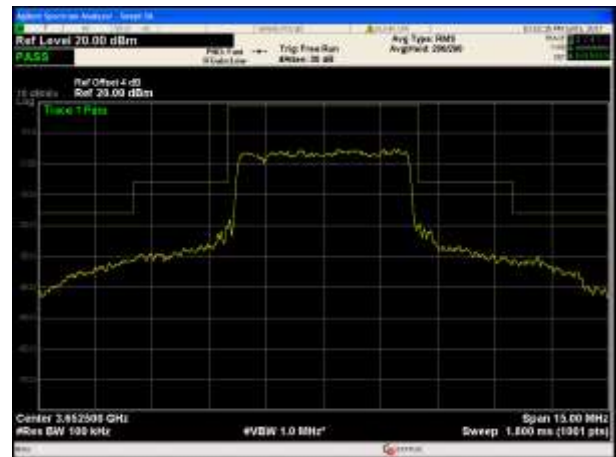

Lowest channel



Middle channel

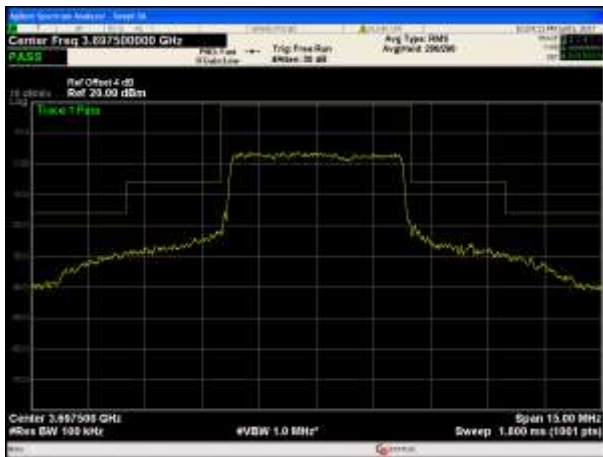

Highest channel

10MHz

QPKS

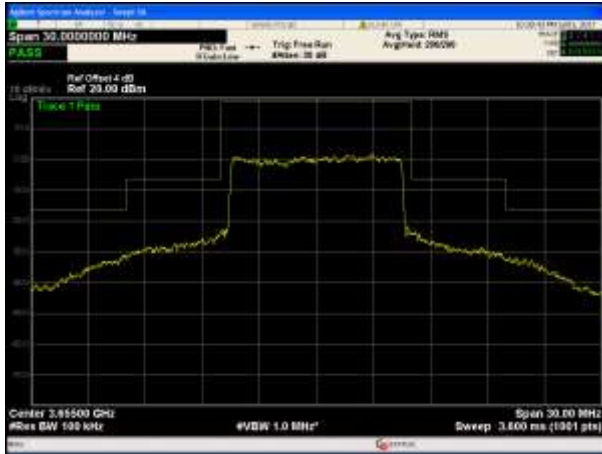

64QAM

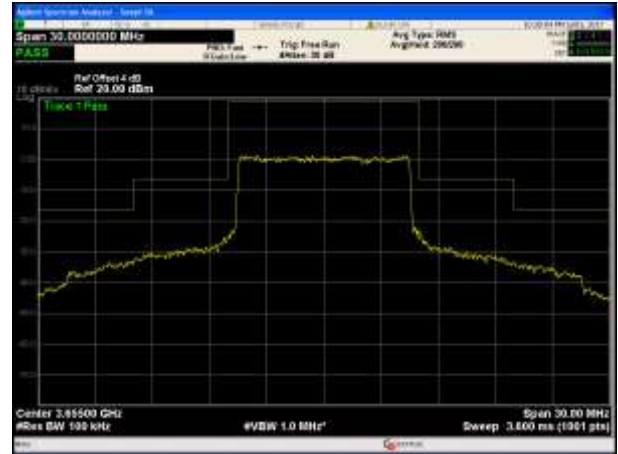

Lowest channel

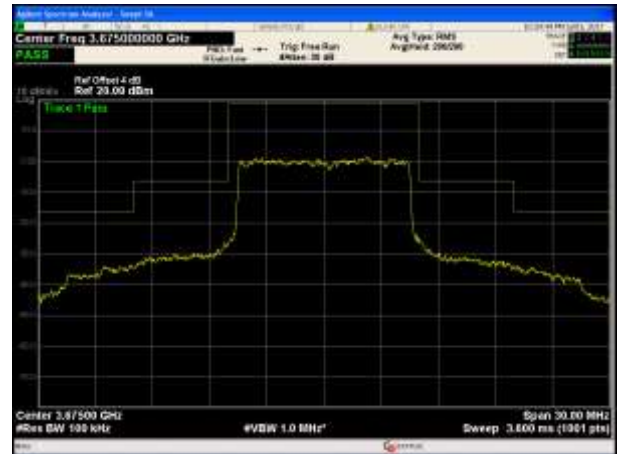
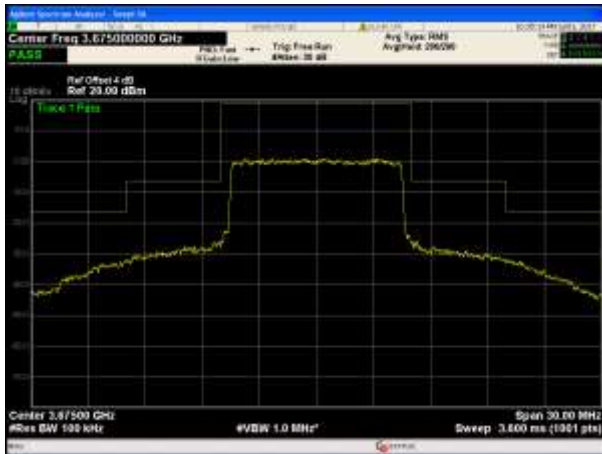

Middle channel

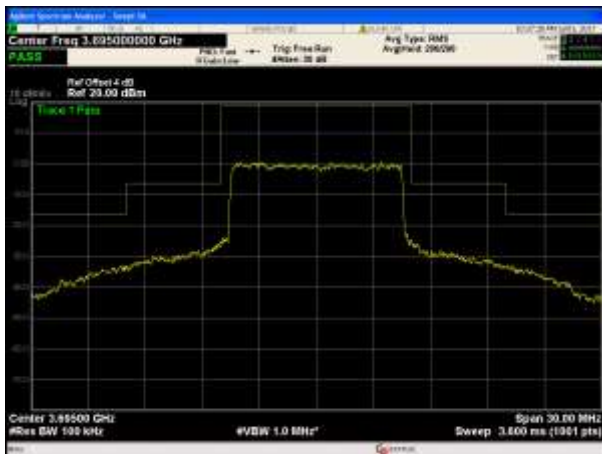

Highest channel

15MHz

QPKS

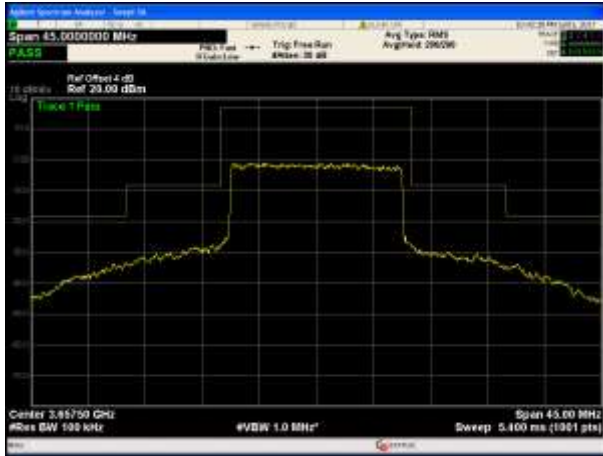

64QAM

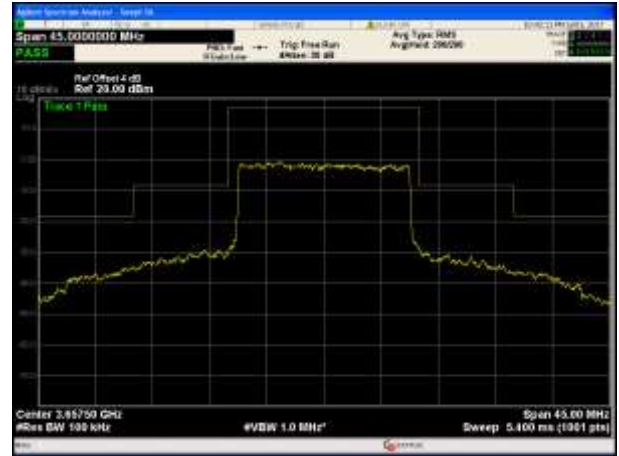

Lowest channel

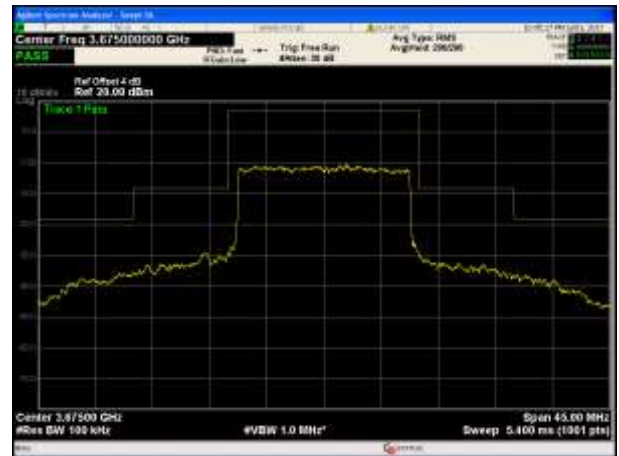

Middle channel

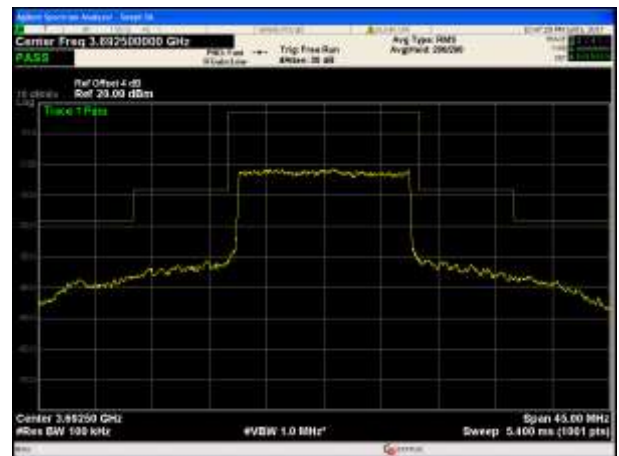
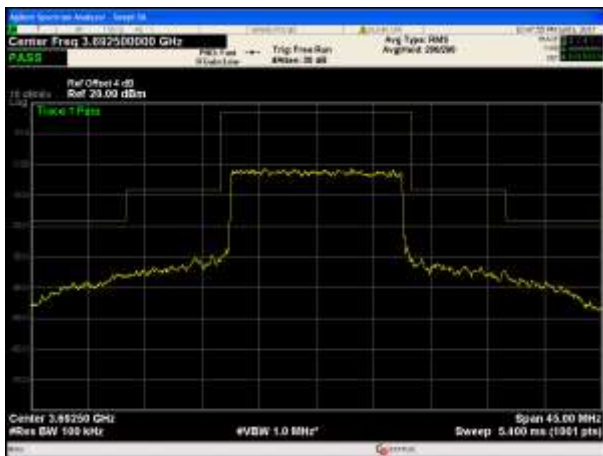

Highest channel

20MHz

QPKS

64QAM

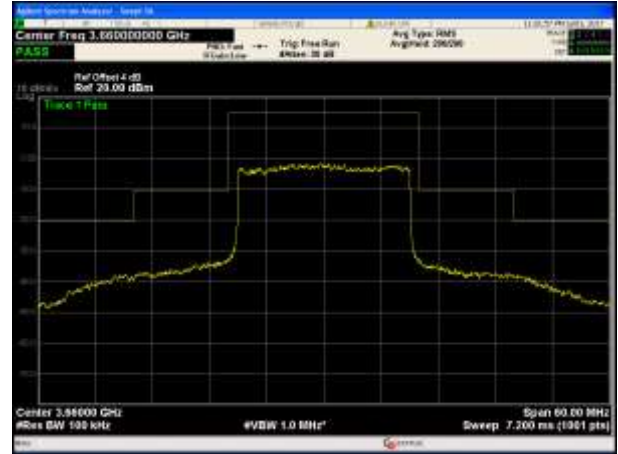
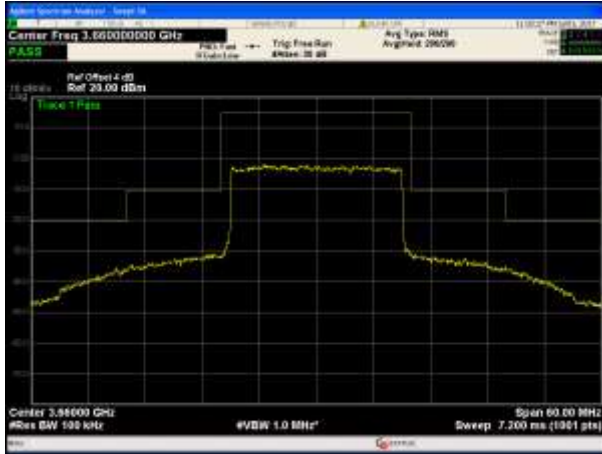

Lowest channel



Middle channel

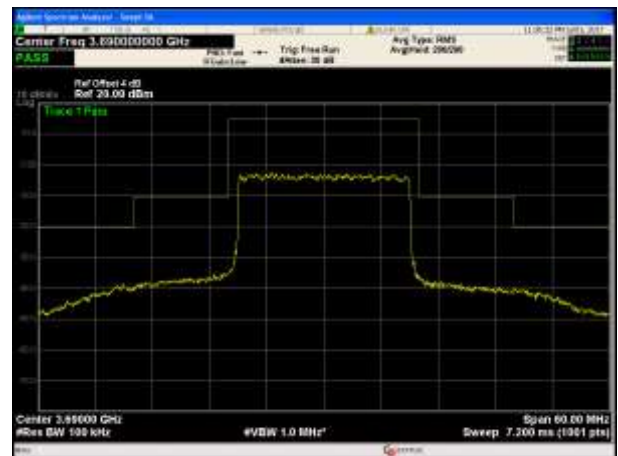
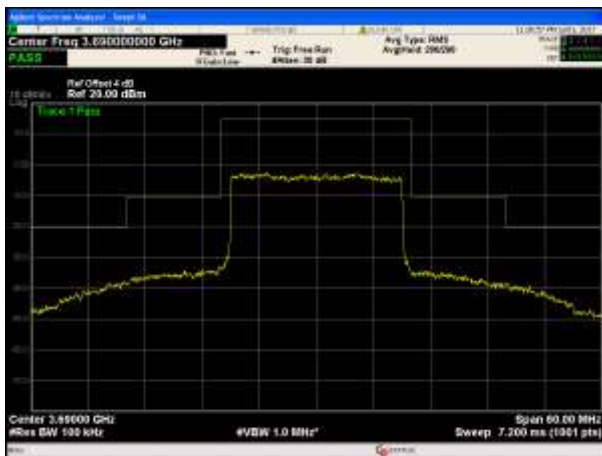

Highest channel

6.8 Out of band emission at antenna terminals

Test Requirement:	FCC part90.1323
Test Method:	FCC part2.1051 and KDB 971168 D01
Limit:	-13dBm
Test Procedure:	<ol style="list-style-type: none"> 1 The RF output of the transceiver was connected to a spectrum analyzer through appropriate attenuation. 2 The resolution bandwidth of the spectrum analyzer was set at 100 kHz when below 1GHz, 1MHz when above 1 GHz; sufficient scans were taken to show the out of band Emissions if any up to 10th harmonic. 3 For the out of band: Set the RBW=100 kHz, VBW=300 kHz when below 1 GHz, RBW =1 MHz, VBW=3 MHz when above 1 GHz, Start=30MHz, Stop= 10th harmonic. 4 Band Edge Requirements: In the 1 MHz bands immediately outside and adjacent to the frequency block, a resolution bandwidth of at least 1 percent of the emission bandwidth of the fundamental emission of the transmitter may be employed to measure the out of band Emissions.
Test Instruments:	Refer to section 5.8 for details
Test mode:	Refer to section 5.3 for details
Test results:	Passed
Remark:	During the test, pre-scan the QPSK, 16QAM modulation, and found the QPSK modulation(10MHz/20MHz middle channel) is the worst case.

Test plots as follows (worst case):

Spurious emission
LTE band 43 Part: 5MHz

Test Mode:	LTE band 43(5 MHz 16QAM) RB Size 25 & RB Offset 0	Test Channel:	Lowest channel
------------	------------------------------------------------------	---------------	----------------

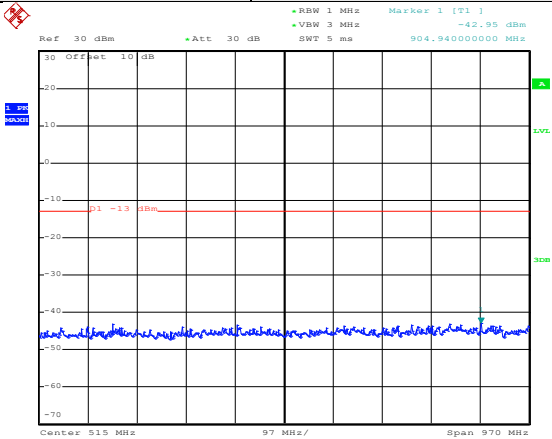

Date: 3.JUL.2017 18:30:56

30MHz~1GHz

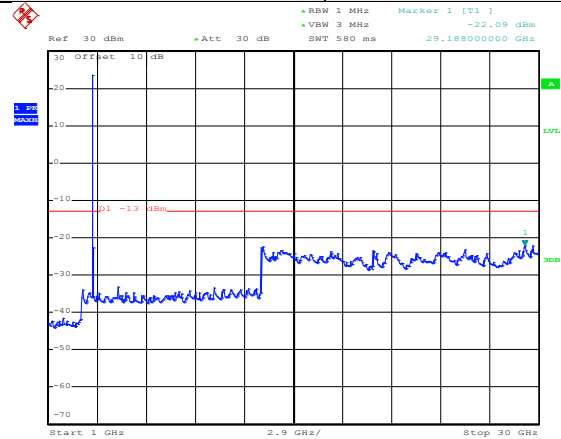

Date: 3.JUL.2017 14:04:27

1GHz~30GHz

Test Mode:	LTE band 43(5 MHz 16QAM) RB Size 25 & RB Offset 0	Test Channel:	Middle channel
------------	------------------------------------------------------	---------------	----------------

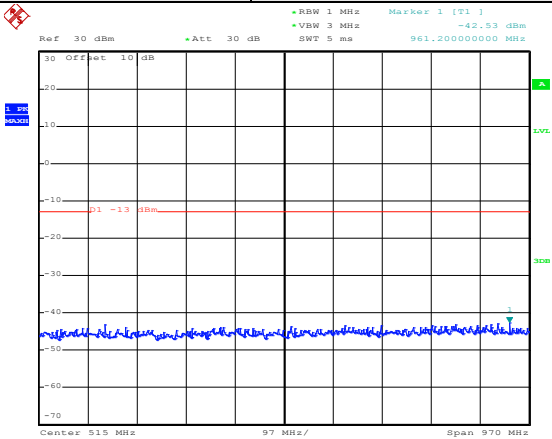

Date: 3.JUL.2017 18:31:13

30MHz~1GHz

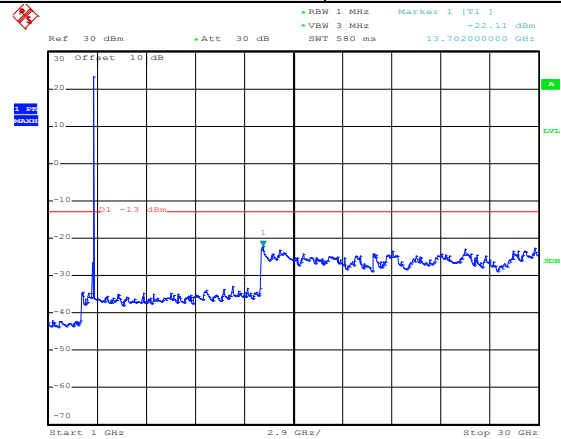

Date: 3.JUL.2017 14:06:00

1GHz~30GHz

Test Mode:	LTE band 43(5 MHz 16QAM) RB Size 25 & RB Offset 0	Test Channel:	Highest channel
------------	------------------------------------------------------	---------------	-----------------

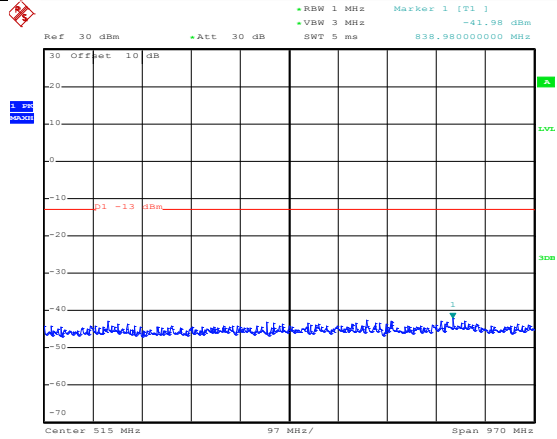

Date: 3.JUL.2017 18:31:26

30MHz~1GHz

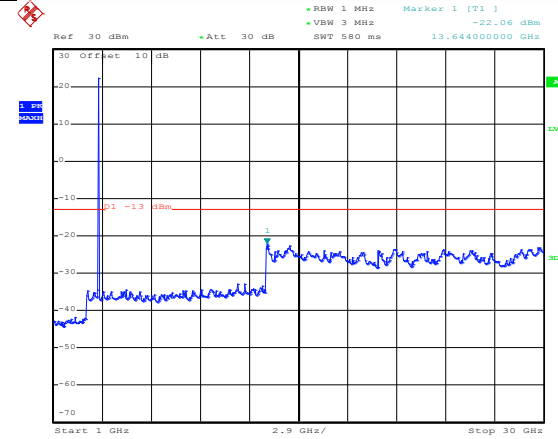

Date: 3.JUL.2017 14:07:29

1GHz~30GHz

LTE band 43 Part: 10MHz

Test Mode:	LTE band 43(10 MHz 16QAM) RB Size 50 & RB Offset 0	Test Channel:	Lowest channel
------------	-------------------------------------------------------	---------------	----------------

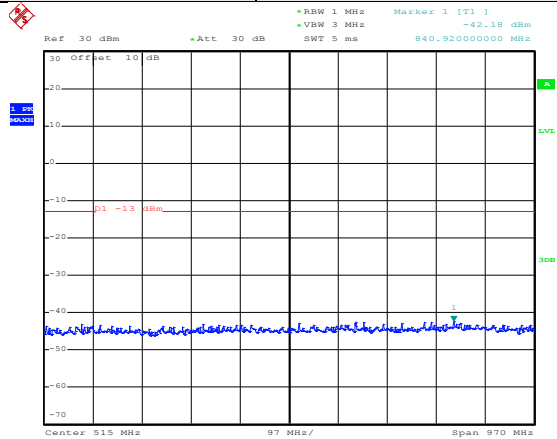

Date: 3.JUL.2017 18:31:48

30MHz~1GHz

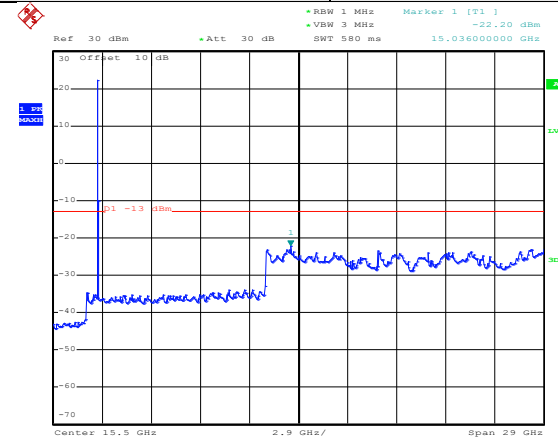

Date: 3.JUL.2017 14:09:00

1GHz~30GHz

Test Mode:	LTE band 43(10 MHz 16QAM) RB Size 50 & RB Offset 0	Test Channel:	Middle channel
------------	-------------------------------------------------------	---------------	----------------

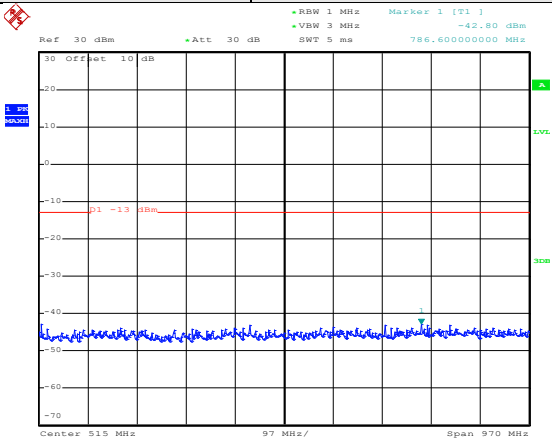

Date: 3.JUL.2017 18:32:01

30MHz~1GHz

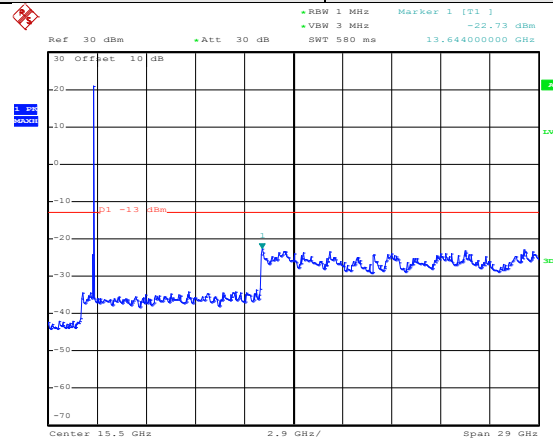

Date: 3.JUL.2017 14:10:15

1GHz~30GHz

Test Mode:	LTE band 43(10 MHz 16QAM) RB Size 50 & RB Offset 0	Test Channel:	Highest channel
------------	-------------------------------------------------------	---------------	-----------------

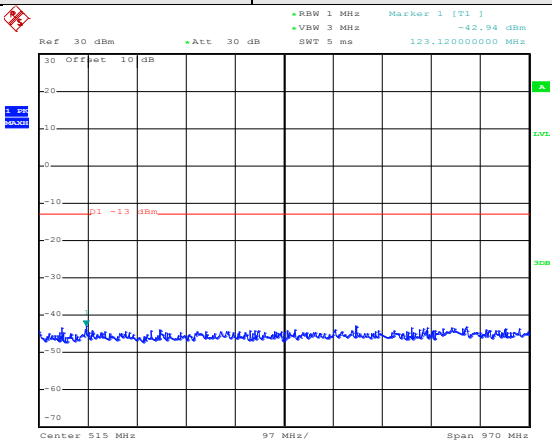

Date: 3.JUL.2017 18:32:12

30MHz~1GHz

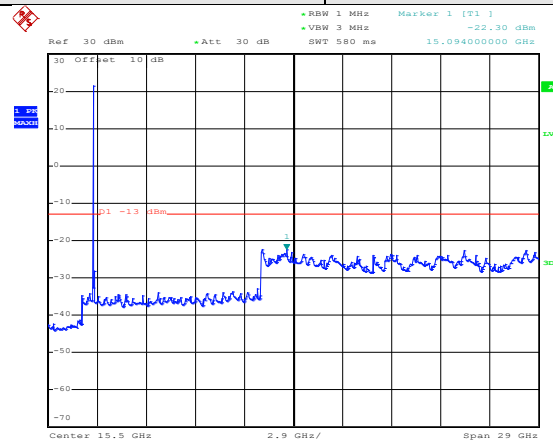

Date: 3.JUL.2017 14:11:25

1GHz~30GHz

LTE band 43 Part: 15MHz

Test Mode:	LTE band 43(15 MHz 16QAM) RB Size 75 & RB Offset 0	Test Channel:	Lowest channel
------------	-------------------------------------------------------	---------------	----------------

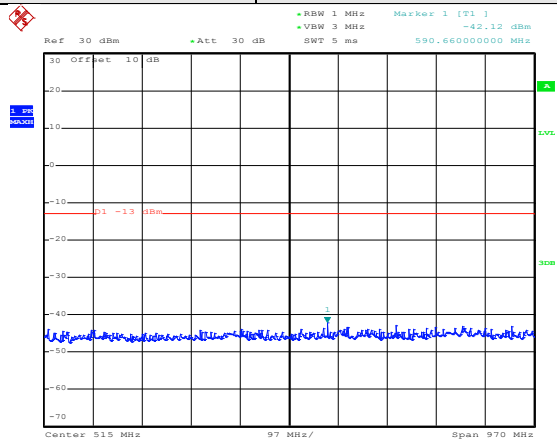

Date: 3.JUL.2017 18:32:27

30MHz~1GHz

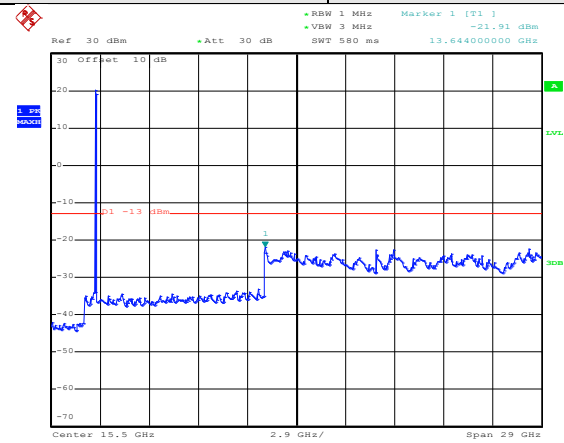

Date: 3.JUL.2017 14:12:48

1GHz~30GHz

Test Mode:	LTE band 43(15 MHz 16QAM) RB Size 75 & RB Offset 0	Test Channel:	Middle channel
------------	-------------------------------------------------------	---------------	----------------

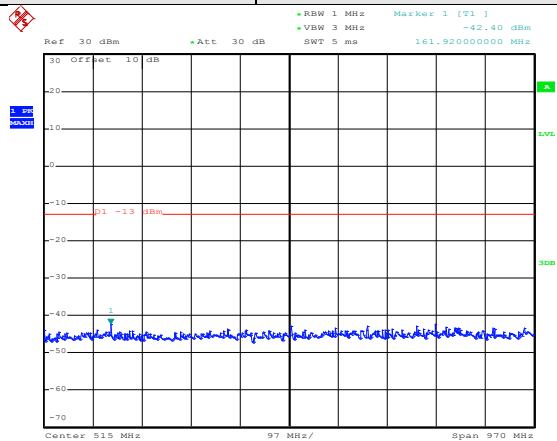

Date: 3.JUL.2017 18:32:39

30MHz~1GHz

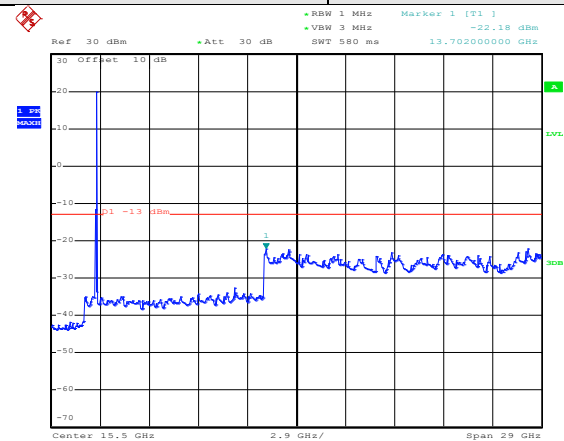

Date: 3.JUL.2017 14:13:57

1GHz~30GHz

Test Mode:	LTE band 43(15 MHz 16QAM) RB Size 75 & RB Offset 0	Test Channel:	Highest channel
------------	-------------------------------------------------------	---------------	-----------------

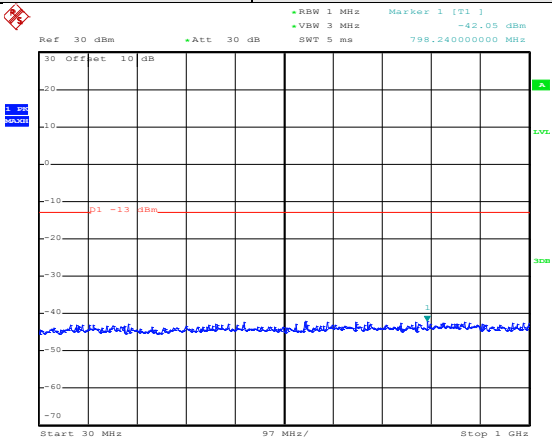

Date: 3.JUL.2017 18:37:02

30MHz~1GHz

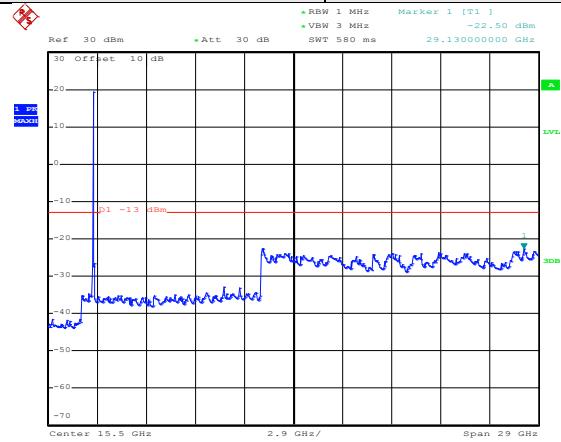

Date: 3.JUL.2017 14:15:01

1GHz~30GHz

Test Mode:	LTE band 43(20 MHz 16QAM) RB Size 100 & RB Offset 0	Test Channel:	Lowest channel
------------	--------------------------------------------------------	---------------	----------------

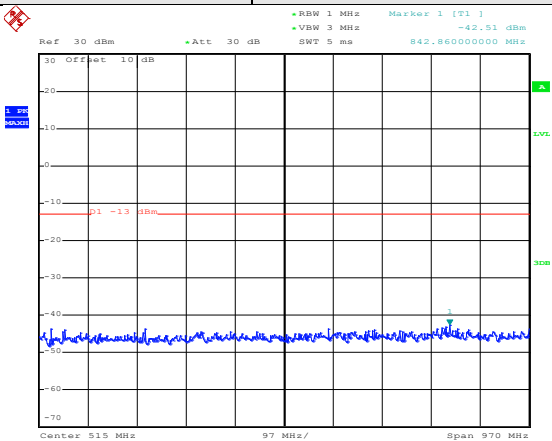

Date: 3.JUL.2017 18:32:59

30MHz~1GHz

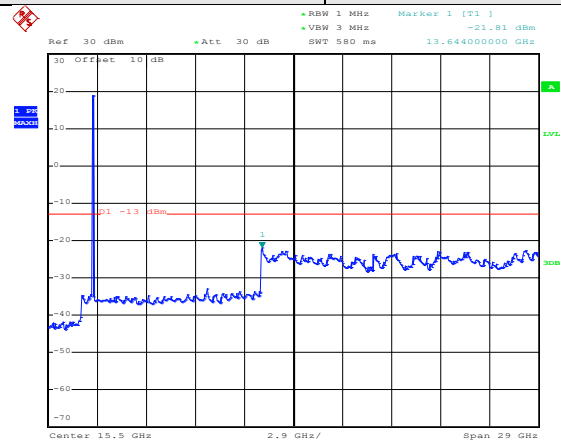

Date: 3.JUL.2017 14:16:42

1GHz~30GHz

Test Mode:	LTE band 43(20 MHz 16QAM) RB Size 100 & RB Offset 0	Test Channel:	Middle channel
------------	--------------------------------------------------------	---------------	----------------

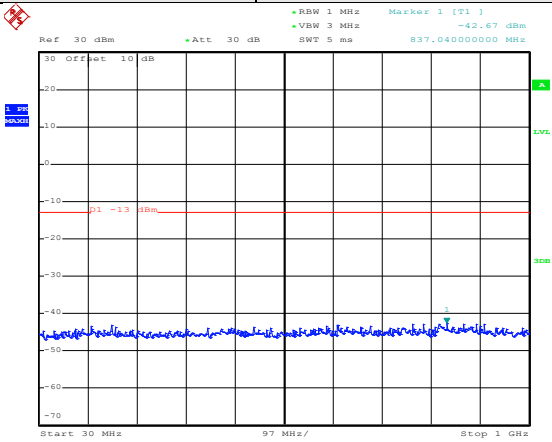

Date: 3.JUL.2017 18:33:14

30MHz~1GHz

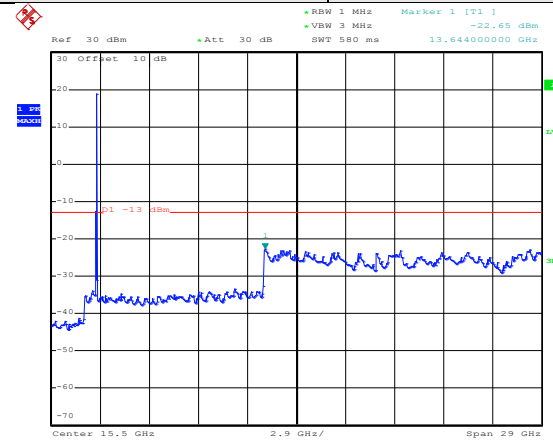

Date: 3.JUL.2017 14:18:06

1GHz~30GHz

Test Mode:	LTE band 43(20 MHz 16QAM) RB Size 100 & RB Offset 0	Test Channel:	Highest channel
------------	--------------------------------------------------------	---------------	-----------------

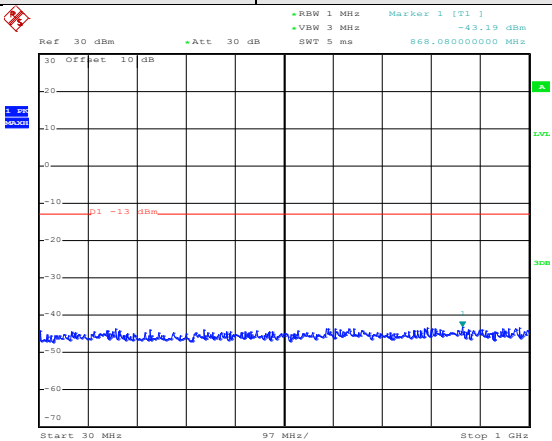

Date: 3.JUL.2017 18:33:26

30MHz~1GHz

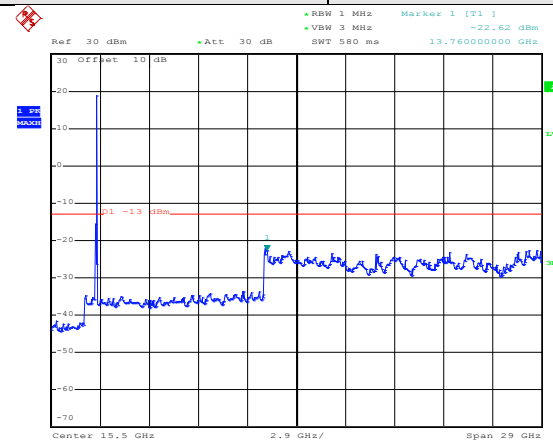

Date: 3.JUL.2017 14:19:18

1GHz~30GHz

LTE band 43 Part: 5MHz

Test Mode:	LTE band 43(5 MHz QPSK) RB Size 25 & RB Offset 0	Test Channel:	Lowest channel
------------	-----------------------------------------------------	---------------	----------------

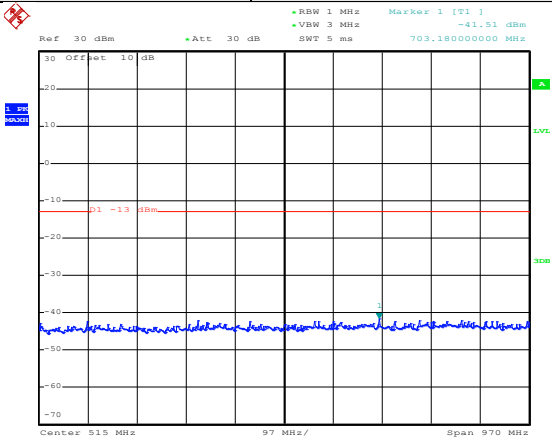

Date: 3.JUL.2017 18:27:53

30MHz~1GHz

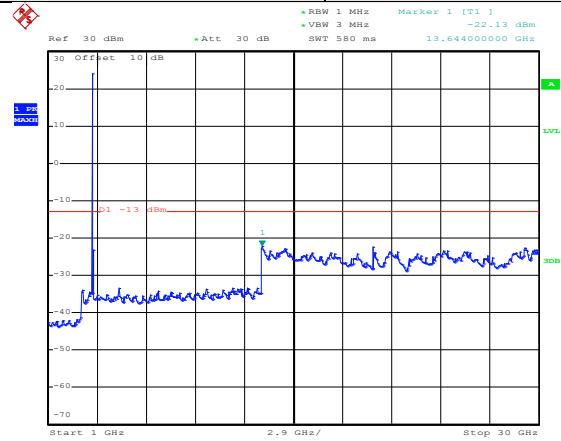

Date: 3.JUL.2017 14:04:18

1GHz~30GHz

Test Mode:	LTE band 43(5 MHz QPSK) RB Size 25 & RB Offset 0	Test Channel:	Middle channel
------------	-----------------------------------------------------	---------------	----------------

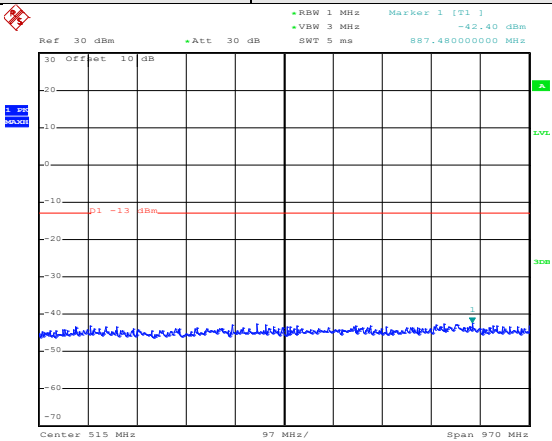

Date: 3.JUL.2017 18:31:07

30MHz~1GHz

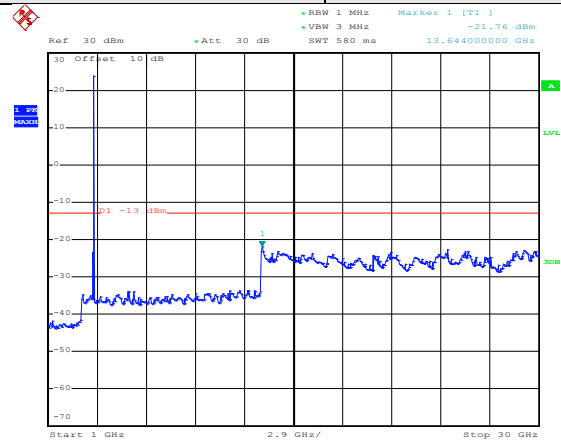

Date: 3.JUL.2017 14:05:54

1GHz~30GHz

Test Mode:	LTE band 43(5 MHz QPSK) RB Size 25 & RB Offset 0	Test Channel:	Highest channel
------------	-----------------------------------------------------	---------------	-----------------

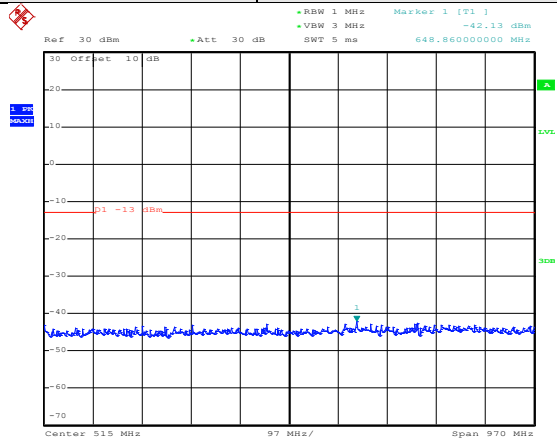

Date: 3.JUL.2017 18:31:22

30MHz~1GHz

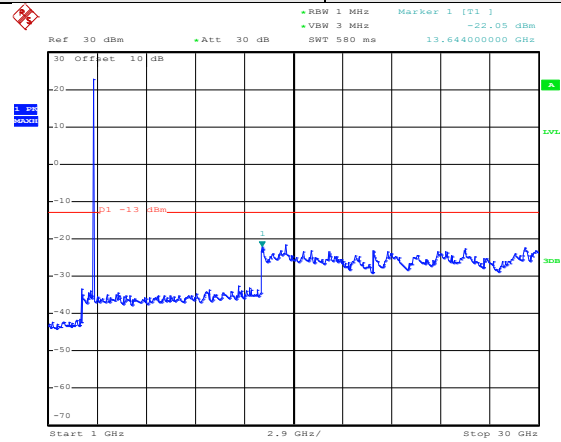

Date: 3.JUL.2017 14:07:22

1GHz~30GHz

LTE band 43 Part: 10MHz

Test Mode:	LTE band 43(10 MHz QPSK) RB Size 50 & RB Offset 0	Test Channel:	Lowest channel
------------	------------------------------------------------------	---------------	----------------

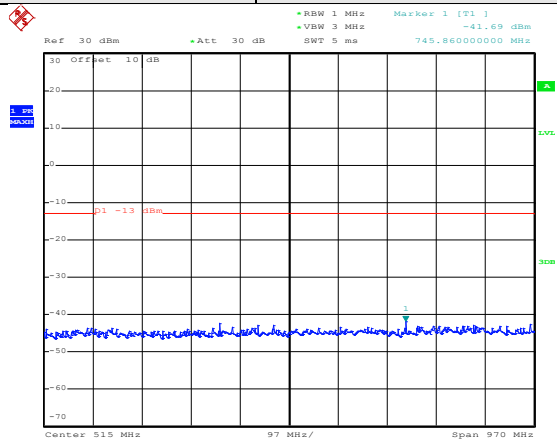

Date: 3.JUL.2017 18:31:35

30MHz~1GHz

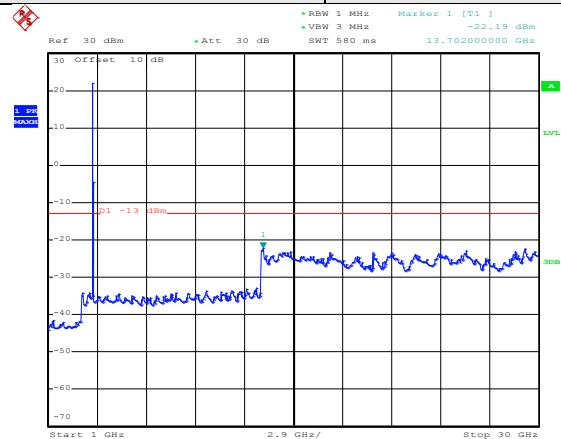

Date: 3.JUL.2017 14:08:47

1GHz~30GHz

Test Mode:	LTE band 43(10 MHz QPSK) RB Size 50 & RB Offset 0	Test Channel:	Middle channel
------------	------------------------------------------------------	---------------	----------------

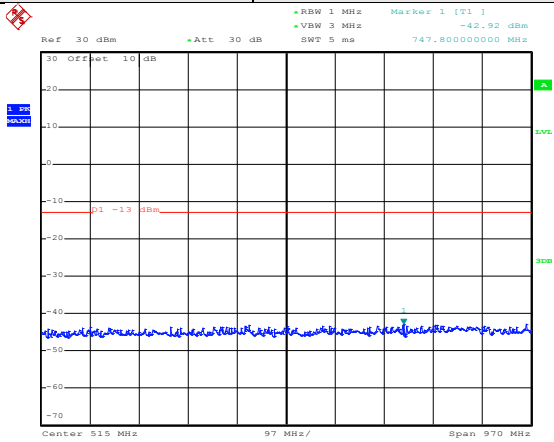

Date: 3.JUL.2017 18:31:57

30MHz~1GHz

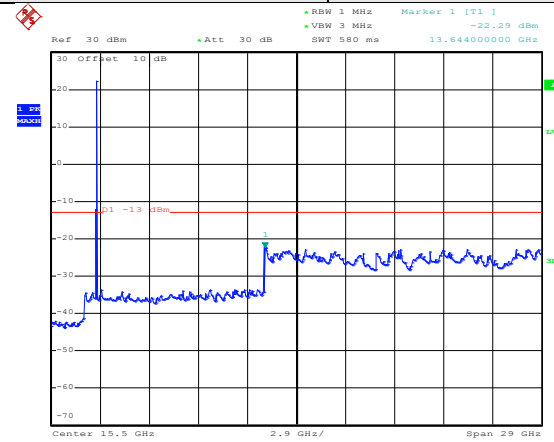

Date: 3.JUL.2017 14:10:09

1GHz~30GHz

Test Mode:	LTE band 43(10 MHz QPSK) RB Size 50 & RB Offset 0	Test Channel:	Highest channel
------------	------------------------------------------------------	---------------	-----------------

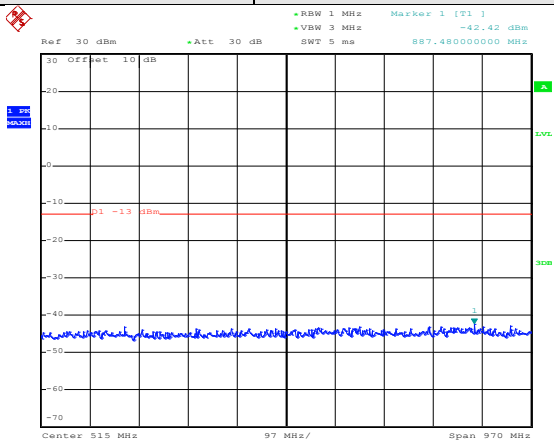

Date: 3.JUL.2017 18:32:08

30MHz~1GHz

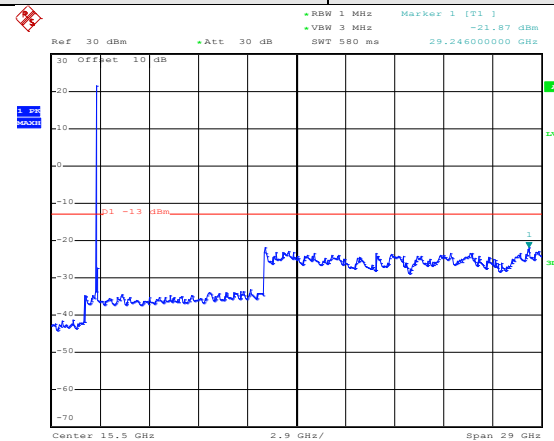

Date: 3.JUL.2017 14:11:18

1GHz~30GHz

LTE band 43 Part: 15MHz

Test Mode:	LTE band 43(15 MHz QPSK) RB Size 75 & RB Offset 0	Test Channel:	Lowest channel
------------	------------------------------------------------------	---------------	----------------

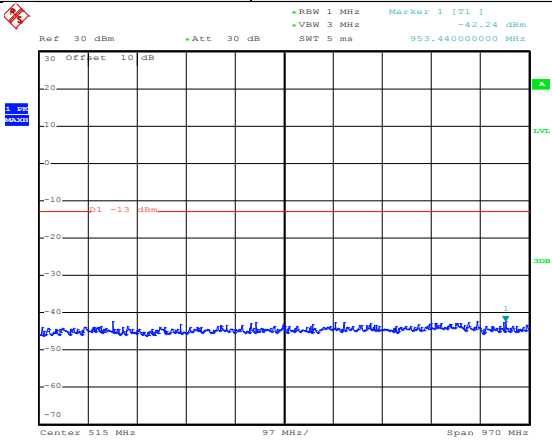

Date: 3.JUL.2017 18:32:23

30MHz~1GHz

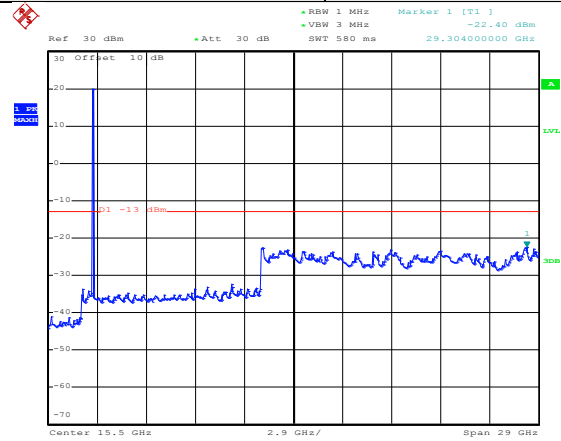

Date: 3.JUL.2017 14:12:40

1GHz~30GHz

Test Mode:	LTE band 43(15 MHz QPSK) RB Size 75 & RB Offset 0	Test Channel:	Middle channel
------------	------------------------------------------------------	---------------	----------------

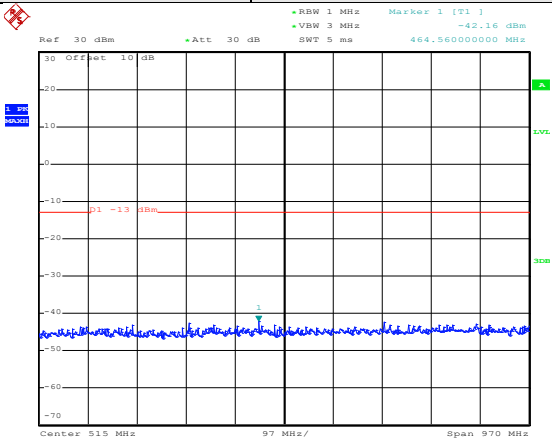

Date: 3.JUL.2017 18:32:34

30MHz~1GHz

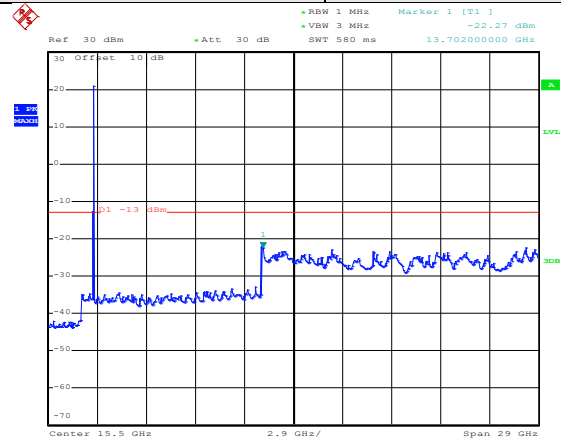

Date: 3.JUL.2017 14:13:50

1GHz~30GHz

Test Mode:	LTE band 43(15 MHz QPSK) RB Size 75 & RB Offset 0	Test Channel:	Highest channel
------------	------------------------------------------------------	---------------	-----------------

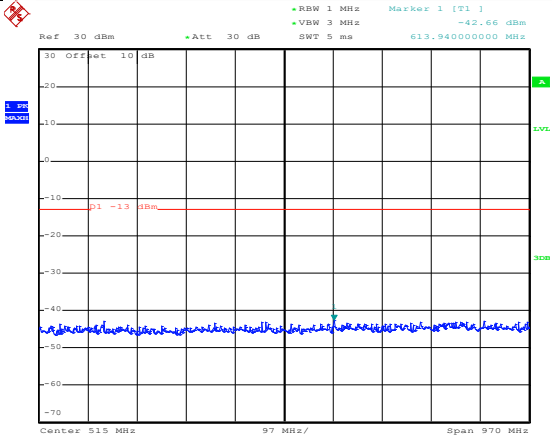

Date: 3.JUL.2017 18:32:46

30MHz~1GHz

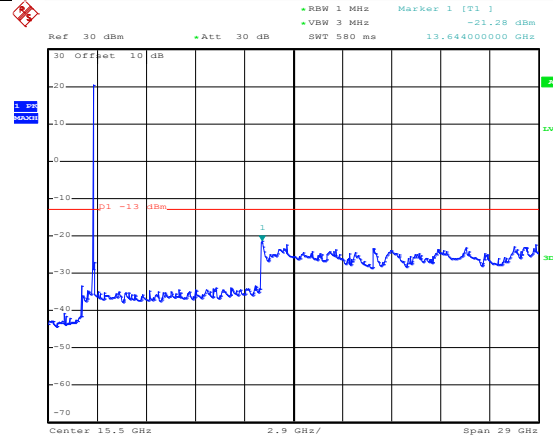

Date: 3.JUL.2017 14:14:53

1GHz~30GHz

Test Mode:	LTE band 43(20 MHz QPSK) RB Size 100 & RB Offset 0	Test Channel:	Lowest channel
------------	-------------------------------------------------------	---------------	----------------

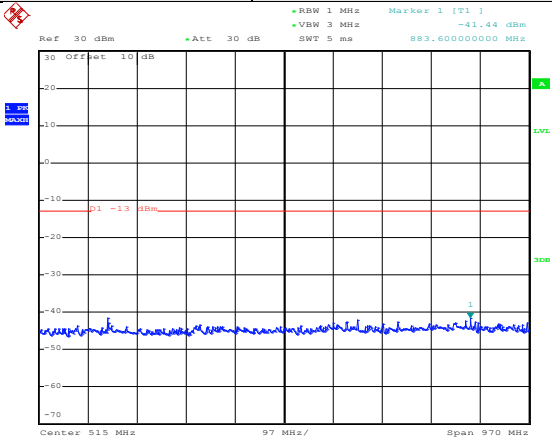

Date: 3.JUL.2017 18:32:55

30MHz~1GHz

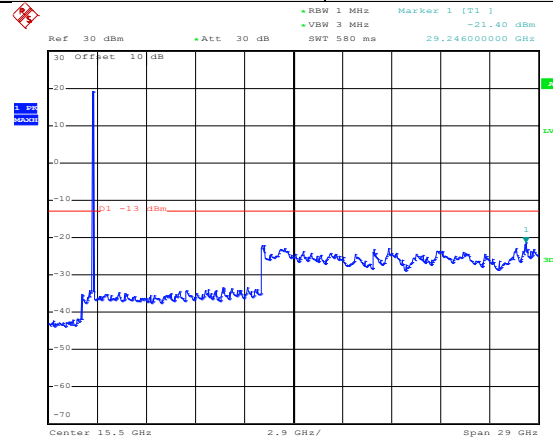

Date: 3.JUL.2017 14:16:24

1GHz~30GHz

Test Mode:	LTE band 43(20 MHz QPSK) RB Size 100 & RB Offset 0	Test Channel:	Middle channel
------------	-------------------------------------------------------	---------------	----------------

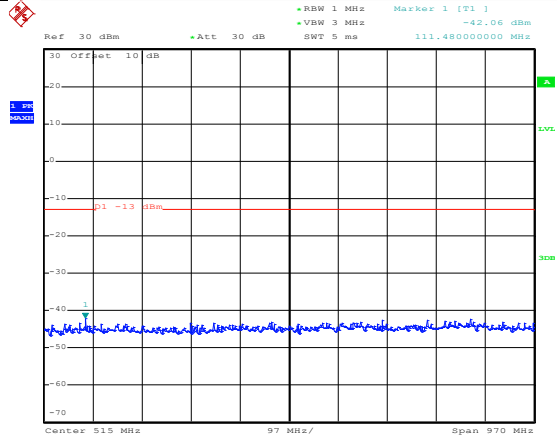

Date: 3.JUL.2017 18:33:07

30MHz~1GHz

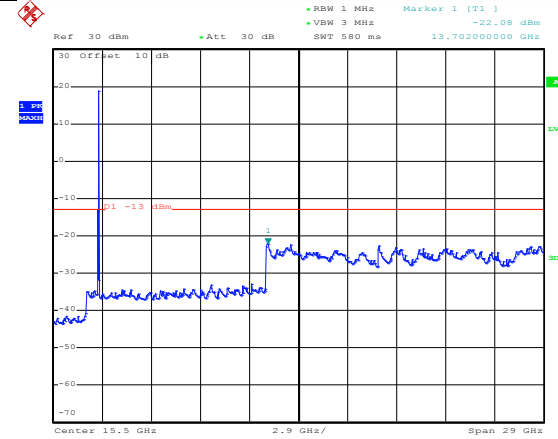

Date: 3.JUL.2017 14:17:54

1GHz~30GHz

Test Mode:	LTE band 43(20 MHz QPSK) RB Size 100 & RB Offset 0	Test Channel:	Highest channel
------------	-------------------------------------------------------	---------------	-----------------

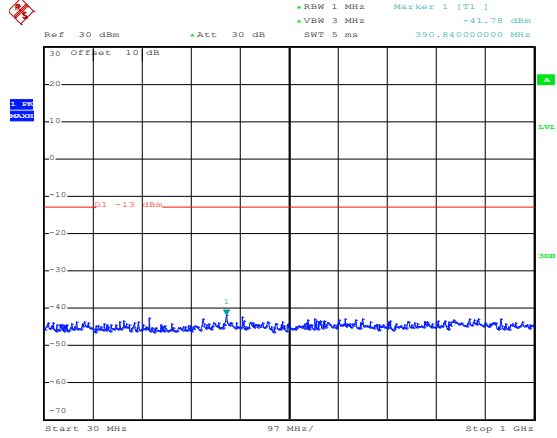

Date: 3.JUL.2017 18:33:22

30MHz~1GHz

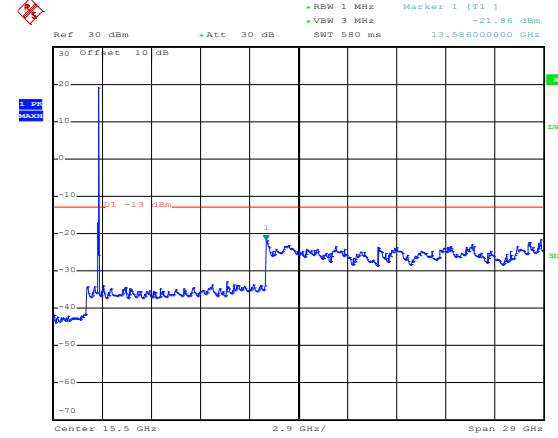

Date: 3.JUL.2017 14:19:10

1GHz~30GHz

Band edge emission:

5MHz

QPSK

16QAM



Lowest channel



Lowest channel



Highest channel



Highest channel

10MHz

QPSK

16QAM

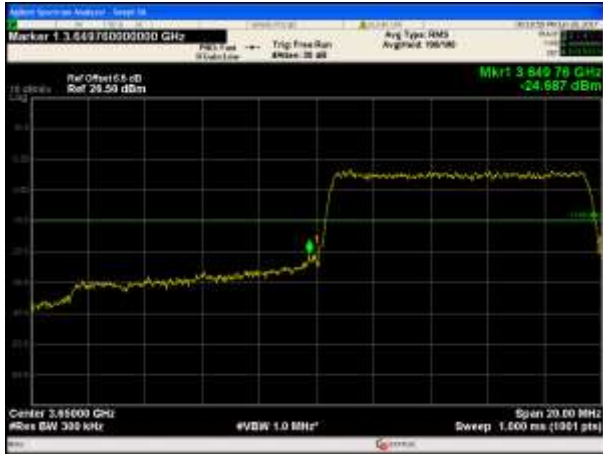

Lowest channel

Lowest channel



Highest channel

Highest channel

15MHz

QPSK

16QAM



Lowest channel

Lowest channel



Highest channel

Highest channel

20MHz

QPSK

16QAM



Lowest channel



Lowest channel



Highest channel



Highest channel

6.9 Field strength of spurious radiation measurement

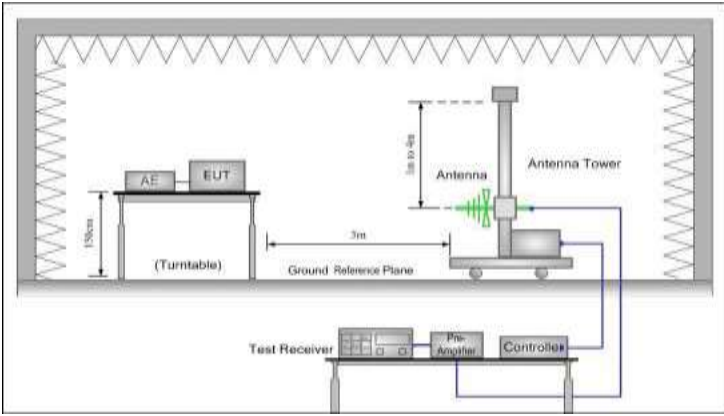
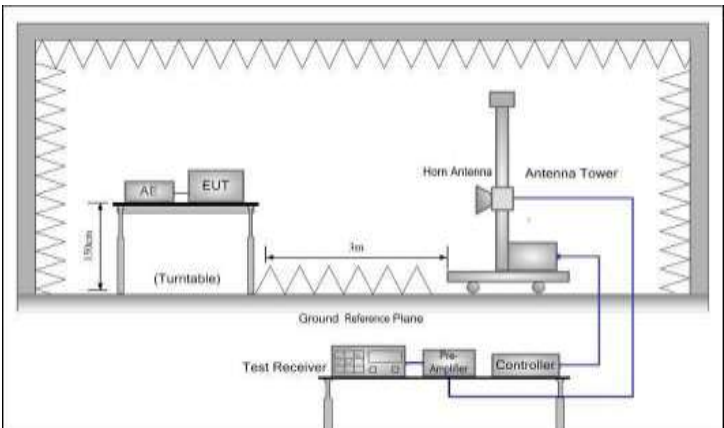
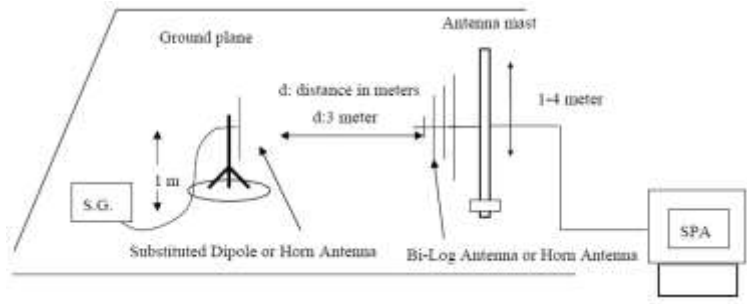
Test Requirement:	Part 90.1323
Test Method:	FCC part2.1053 and KDB 971168 D01
Limit:	-13dBm
Test setup:	<p>Below 1GHz</p>  <p>Above 1GHz</p>  <p>Substituted method:</p> 
Test Procedure:	<ol style="list-style-type: none"> 1. The EUT was placed on an non-conductive turntable using a non-conductive support. The radiated emission at the fundamental frequency was measured at 3 m with a test antenna and EMI spectrum analyzer. 2. During the tests, the antenna height and the EUT azimuth were varied in order to identify the maximum level of emissions from the EUT. This maximization process was repeated with the EUT positioned in each of its three orthogonal orientations. 3. The frequency range up to tenth harmonic was investigated for each

	<p>of three fundamental frequency (low, middle and high channels). Once spurious emission was identified, the power of the emission was determined using the substitution method.</p> <p>4. The spurious emissions attenuation was calculated as the difference between radiated power at the fundamental frequency and the spurious emissions frequency.</p> $\text{ERP / EIRP} = \text{S.G. output (dBm)} + \text{Antenna Gain(dB/dBi)} - \text{Cable Loss (dB)}$
Test Uncertainty:	± 4.88 dB
Test Instruments:	Refer to section 5.8 for details
Test mode:	Refer to section 5.3 for details.
Test results:	Passed
Remark:	During the test, pre-scan the QPSK, 16QAM modulation, and found the QPSK modulation is the worst case.

Measurement Data (worst case):

5MHz for QPSK				
Frequency (MHz)	Spurious Emission		Limit (dBm)	Result
	Polarization	Level (dBm)		
Lowest				
7305.00	Vertical	-35.05	-13	Pass
10957.50	V	-29.16		
7305.00	Horizontal	-33.34		
10957.50	H	-32.21		
Middle				
7350.00	Vertical	-32.94	-13	Pass
11025.00	V	-37.33		
7350.00	Horizontal	-37.75		
11025.00	H	-36.35		
Highest				
7395.00	Vertical	-33.77	-13	Pass
11070.00	V	-35.61		
7395.00	Horizontal	-34.88		
11070.00	H	-33.76		

Remark:

- The emission levels of below 1 GHz are very lower than the limit and not show in test report.

10MHz for QPSK				
Frequency (MHz)	Spurious Emission		Limit (dBm)	Result
	Polarization	Level (dBm)		
Lowest				
7310.00	Vertical	-35.52	-13	Pass
10985.00	V	-29.31		
7310.00	Horizontal	-33.35		
10985.00	H	-32.03		
Middle				
7350.00	Vertical	-32.51	-13	Pass
11025.00	V	-37.35		
7350.00	Horizontal	-37.52		
11025.00	H	-36.54		
Highest				
7390.00	Vertical	-33.11	-13	Pass
11065.00	V	-35.03		
7390.00	Horizontal	-34.26		
11065.00	H	-33.89		

Remark:

- The emission levels of below 1 GHz are very lower than the limit and not show in test report.

15MHz for QPSK				
Frequency (MHz)	Spurious Emission		Limit (dBm)	Result
	Polarization	Level (dBm)		
Lowest				
7315.00	Vertical	-35.79	-13	Pass
10990.00	V	-29.93		
7315.00	Horizontal	-33.84		
10990.00	H	-32.77		
Middle				
7350.00	Vertical	-32.89	-13	Pass
11025.00	V	-37.88		
7350.00	Horizontal	-37.92		
11025.00	H	-36.77		
Highest				
7385.00	Vertical	-33.52	-13	Pass
11060.00	V	-35.42		
7385.00	Horizontal	-34.26		
11060.00	H	-33.88		

Remark:

- The emission levels of below 1 GHz are very lower than the limit and not show in test report.

20MHz for QPSK				
Frequency (MHz)	Spurious Emission		Limit (dBm)	Result
	Polarization	Level (dBm)		
Lowest				
7320.00	Vertical	-35.42	-13	Pass
10995.00	V	-29.76		
7320.00	Horizontal	-33.20		
10995.00	H	-32.76		
Middle				
7350.00	Vertical	-32.03	-13	Pass
11025.00	V	-37.21		
7350.00	Horizontal	-37.42		
11025.00	H	-36.88		
Highest				
7380.00	Vertical	-33.42	-13	Pass
11055.00	V	-35.51		
7380.00	Horizontal	-34.08		
11055.00	H	-33.31		

Remark:

- The emission levels of below 1 GHz are very lower than the limit and not show in test report.

6.10 Frequency stability V.S. Temperature measurement

Test Requirement:	FCC Part90.213(a)																																																																														
Test Method:	FCC Part2.1055(a)(1)(b) and KDB 971168 D01																																																																														
Limit:	<p>FCC:</p> <table border="1"> <thead> <tr> <th rowspan="2">Frequency range (MHz)</th> <th rowspan="2">Fixed and base stations (±ppm)</th> <th colspan="2">Mobile stations (±ppm)</th> </tr> <tr> <th>Over 2 watts output power</th> <th>2 watts or less output power</th> </tr> </thead> <tbody> <tr> <td>Below 25</td> <td>100</td> <td>100</td> <td>200</td> </tr> <tr> <td>25-50</td> <td>20</td> <td>20</td> <td>50</td> </tr> <tr> <td>72-76</td> <td>5</td> <td></td> <td>50</td> </tr> <tr> <td>150-174</td> <td>5</td> <td>5</td> <td>50</td> </tr> <tr> <td>216-220</td> <td>1.0</td> <td></td> <td>1.0</td> </tr> <tr> <td>220-222</td> <td>0.1</td> <td>1.5</td> <td>1.5</td> </tr> <tr> <td>421-512</td> <td>2.5</td> <td>5</td> <td>5</td> </tr> <tr> <td>806-809</td> <td>1.0</td> <td>1.5</td> <td>1.5</td> </tr> <tr> <td>809-824</td> <td>1.5</td> <td>2.5</td> <td>2.5</td> </tr> <tr> <td>851-854</td> <td>1.0</td> <td>1.5</td> <td>1.5</td> </tr> <tr> <td>854-869</td> <td>1.5</td> <td>2.5</td> <td>2.5</td> </tr> <tr> <td>896-901</td> <td>0.1</td> <td>1.5</td> <td>1.5</td> </tr> <tr> <td>902-928</td> <td>2.5</td> <td>2.5</td> <td>2.5</td> </tr> <tr> <td>902-928</td> <td>2.5</td> <td>2.5</td> <td>2.5</td> </tr> <tr> <td>929-930</td> <td>1.5</td> <td></td> <td></td> </tr> <tr> <td>935-940</td> <td>0.1</td> <td>1.5</td> <td>1.5</td> </tr> <tr> <td>1427-1435</td> <td>300</td> <td>300</td> <td>300</td> </tr> <tr> <td>Above 2450</td> <td></td> <td></td> <td></td> </tr> </tbody> </table>	Frequency range (MHz)	Fixed and base stations (±ppm)	Mobile stations (±ppm)		Over 2 watts output power	2 watts or less output power	Below 25	100	100	200	25-50	20	20	50	72-76	5		50	150-174	5	5	50	216-220	1.0		1.0	220-222	0.1	1.5	1.5	421-512	2.5	5	5	806-809	1.0	1.5	1.5	809-824	1.5	2.5	2.5	851-854	1.0	1.5	1.5	854-869	1.5	2.5	2.5	896-901	0.1	1.5	1.5	902-928	2.5	2.5	2.5	902-928	2.5	2.5	2.5	929-930	1.5			935-940	0.1	1.5	1.5	1427-1435	300	300	300	Above 2450			
Frequency range (MHz)	Fixed and base stations (±ppm)			Mobile stations (±ppm)																																																																											
		Over 2 watts output power	2 watts or less output power																																																																												
Below 25	100	100	200																																																																												
25-50	20	20	50																																																																												
72-76	5		50																																																																												
150-174	5	5	50																																																																												
216-220	1.0		1.0																																																																												
220-222	0.1	1.5	1.5																																																																												
421-512	2.5	5	5																																																																												
806-809	1.0	1.5	1.5																																																																												
809-824	1.5	2.5	2.5																																																																												
851-854	1.0	1.5	1.5																																																																												
854-869	1.5	2.5	2.5																																																																												
896-901	0.1	1.5	1.5																																																																												
902-928	2.5	2.5	2.5																																																																												
902-928	2.5	2.5	2.5																																																																												
929-930	1.5																																																																														
935-940	0.1	1.5	1.5																																																																												
1427-1435	300	300	300																																																																												
Above 2450																																																																															
Test setup:	<p>Note : Measurement setup for testing on Antenna connector</p>																																																																														
Test procedure:	<ol style="list-style-type: none"> 1. The equipment under test was connected to an external DC power supply and input rated voltage. 2. RF output was connected to a frequency counter or spectrum analyzer via feed through attenuators. 3. The EUT was placed inside the temperature chamber. 4. Set the spectrum analyzer RBW low enough to obtain the desired frequency resolution and measure EUT 25°C operating frequency as reference frequency. 5. Turn EUT off and set the chamber temperature to -30°C. After the temperature stabilized for approximately 30 minutes recorded the frequency. 6. Repeat step measure with 10°C increased per stage until the highest temperature of +50°C reached 																																																																														
Test Instruments:	Refer to section 5.8 for details																																																																														
Test mode:	Refer to section 5.3 for details																																																																														
Test results:	Passed																																																																														
Remark:	All three channels of all modulations have been tested, but only the worst channel and the worst modulation show in this test item.																																																																														

Measurement Data (the worst channel):

Band43

Reference Frequency: Lowest channel=3652.5MHz(5MHz for QPSK)			
Power supplied (Vdc)	Temperature (°C)	Frequency error	
		Hz	ppm
24.00	-40	192	0.052567
	-25	181	0.049555
	-10	174	0.047639
	0	165	0.045175
	10	132	0.036140
	20	133	0.036413
	30	150	0.041068
	40	148	0.040520
	55	102	0.027926
Reference Frequency: Lowest channel=3655.0MHz(10MHz for QPSK)			
Power supplied (Vdc)	Temperature (°C)	Frequency error	
		Hz	ppm
24.00	-40	187	0.051163
	-20	176	0.048153
	-10	180	0.049248
	0	144	0.039398
	10	150	0.041040
	20	132	0.036115
	30	126	0.034473
	40	120	0.032832
	55	113	0.030917

Reference Frequency: Lowest channel=3657.5MHz(15MHz for QPSK)			
Power supplied (Vdc)	Temperature (°C)	Frequency error	
		Hz	ppm
24.00	-40	199	0.054409
	-25	188	0.051401
	-10	176	0.048120
	0	163	0.044566
	10	133	0.036364
	20	150	0.041012
	30	148	0.040465
	40	108	0.029528
	55	119	0.032536
Reference Frequency: Lowest channel=3660.0MHz(20MHz for QPSK)			
Power supplied (Vdc)	Temperature (°C)	Frequency error	
		Hz	ppm
24.00	-40	187	0.051093
	-20	165	0.045082
	-10	174	0.047541
	0	123	0.033607
	10	160	0.043716
	20	144	0.039344
	30	150	0.040984
	40	108	0.029508
	55	133	0.036339

Reference Frequency: Lowest channel=3652.5MHz(5MHz for 16QAM)			
Power supplied (Vdc)	Temperature (°C)	Frequency error	
		Hz	ppm
24.00	-40	196	0.053662
	-25	151	0.041342
	-10	180	0.049281
	0	171	0.046817
	10	141	0.038604
	20	132	0.036140
	30	155	0.042437
	40	158	0.043258
	55	108	0.029569
Reference Frequency: Lowest channel=3655.0MHz(10MHz for 16QAM)			
Power supplied (Vdc)	Temperature (°C)	Frequency error	
		Hz	ppm
24.00	-40	199	0.054446
	-20	181	0.049521
	-10	165	0.045144
	0	171	0.046785
	10	123	0.033653
	20	132	0.036115
	30	136	0.037209
	40	128	0.035021
	55	144	0.039398

Reference Frequency: Lowest channel=3657.5MHz(15MHz for 16QAM)			
Power supplied (Vdc)	Temperature (°C)	Frequency error	
		Hz	ppm
24.00	-40	196	0.053589
	-25	185	0.050581
	-10	144	0.039371
	0	171	0.046753
	10	132	0.036090
	20	136	0.037184
	30	125	0.034176
	40	105	0.028708
	55	118	0.032262
Reference Frequency: Lowest channel=3660.0MHz(20MHz for 16QAM)			
Power supplied (Vdc)	Temperature (°C)	Frequency error	
		Hz	ppm
24.00	-40	198	0.054098
	-20	180	0.049180
	-10	156	0.042623
	0	132	0.036066
	10	144	0.039344
	20	171	0.046721
	30	105	0.028689
	40	116	0.031694
	55	128	0.034973

6.11 Frequency stability V.S. Voltage measurement

Test Requirement:	FCC Part 90.213(a)																																																																																																			
Test Method:	FCC Part 2.1055(a)(1)(b) and KDB 971168 D01																																																																																																			
Limit:	<p>FCC:</p> <table border="1"> <thead> <tr> <th rowspan="2">Frequency range (MHz)</th> <th colspan="2">Fixed and base stations (±ppm)</th> <th colspan="2">Mobile stations (±ppm)</th> </tr> <tr> <th>Fixed and base stations (±ppm)</th> <th>Over 2 watts output power</th> <th>Over 2 watts output power</th> <th>2 watts or less output power</th> </tr> </thead> <tbody> <tr> <td>Below 25</td> <td>100</td> <td>100</td> <td>100</td> <td>200</td> </tr> <tr> <td>25-50</td> <td>20</td> <td>20</td> <td>20</td> <td>50</td> </tr> <tr> <td>72-76</td> <td>5</td> <td>5</td> <td>5</td> <td>50</td> </tr> <tr> <td>150-174</td> <td>5</td> <td>5</td> <td>5</td> <td>50</td> </tr> <tr> <td>216-220</td> <td>1.0</td> <td>1.0</td> <td>1.0</td> <td>1.0</td> </tr> <tr> <td>220-222</td> <td>0.1</td> <td>1.5</td> <td>1.5</td> <td>1.5</td> </tr> <tr> <td>421-512</td> <td>2.5</td> <td>5</td> <td>5</td> <td>5</td> </tr> <tr> <td>806-809</td> <td>1.0</td> <td>1.5</td> <td>1.5</td> <td>1.5</td> </tr> <tr> <td>809-824</td> <td>1.5</td> <td>2.5</td> <td>2.5</td> <td>2.5</td> </tr> <tr> <td>851-854</td> <td>1.0</td> <td>1.5</td> <td>1.5</td> <td>1.5</td> </tr> <tr> <td>854-869</td> <td>1.5</td> <td>2.5</td> <td>2.5</td> <td>2.5</td> </tr> <tr> <td>896-901</td> <td>0.1</td> <td>1.5</td> <td>1.5</td> <td>1.5</td> </tr> <tr> <td>902-928</td> <td>2.5</td> <td>2.5</td> <td>2.5</td> <td>2.5</td> </tr> <tr> <td>902-928</td> <td>2.5</td> <td>2.5</td> <td>2.5</td> <td>2.5</td> </tr> <tr> <td>929-930</td> <td>1.5</td> <td>1.5</td> <td>1.5</td> <td>1.5</td> </tr> <tr> <td>935-940</td> <td>0.1</td> <td>1.5</td> <td>1.5</td> <td>1.5</td> </tr> <tr> <td>1427-1435</td> <td>300</td> <td>300</td> <td>300</td> <td>300</td> </tr> <tr> <td>Above 2450</td> <td></td> <td></td> <td></td> <td></td> </tr> </tbody> </table>	Frequency range (MHz)	Fixed and base stations (±ppm)		Mobile stations (±ppm)		Fixed and base stations (±ppm)	Over 2 watts output power	Over 2 watts output power	2 watts or less output power	Below 25	100	100	100	200	25-50	20	20	20	50	72-76	5	5	5	50	150-174	5	5	5	50	216-220	1.0	1.0	1.0	1.0	220-222	0.1	1.5	1.5	1.5	421-512	2.5	5	5	5	806-809	1.0	1.5	1.5	1.5	809-824	1.5	2.5	2.5	2.5	851-854	1.0	1.5	1.5	1.5	854-869	1.5	2.5	2.5	2.5	896-901	0.1	1.5	1.5	1.5	902-928	2.5	2.5	2.5	2.5	902-928	2.5	2.5	2.5	2.5	929-930	1.5	1.5	1.5	1.5	935-940	0.1	1.5	1.5	1.5	1427-1435	300	300	300	300	Above 2450				
Frequency range (MHz)	Fixed and base stations (±ppm)		Mobile stations (±ppm)																																																																																																	
	Fixed and base stations (±ppm)	Over 2 watts output power	Over 2 watts output power	2 watts or less output power																																																																																																
Below 25	100	100	100	200																																																																																																
25-50	20	20	20	50																																																																																																
72-76	5	5	5	50																																																																																																
150-174	5	5	5	50																																																																																																
216-220	1.0	1.0	1.0	1.0																																																																																																
220-222	0.1	1.5	1.5	1.5																																																																																																
421-512	2.5	5	5	5																																																																																																
806-809	1.0	1.5	1.5	1.5																																																																																																
809-824	1.5	2.5	2.5	2.5																																																																																																
851-854	1.0	1.5	1.5	1.5																																																																																																
854-869	1.5	2.5	2.5	2.5																																																																																																
896-901	0.1	1.5	1.5	1.5																																																																																																
902-928	2.5	2.5	2.5	2.5																																																																																																
902-928	2.5	2.5	2.5	2.5																																																																																																
929-930	1.5	1.5	1.5	1.5																																																																																																
935-940	0.1	1.5	1.5	1.5																																																																																																
1427-1435	300	300	300	300																																																																																																
Above 2450																																																																																																				
Test setup:	<p>Note : Measurement setup for testing on Antenna connector</p>																																																																																																			
Test procedure:	<ol style="list-style-type: none"> 1. Set chamber temperature to 25°C. Use a variable DC power source to power the EUT and set the voltage to rated voltage. 2. Set the spectrum analyzer RBW low enough to obtain the desired frequency resolution and recorded the frequency. 3. Reduce the input voltage to specify extreme voltage variation (+/- 15%) and endpoint, record the maximum frequency change. 																																																																																																			
Test Instruments:	Refer to section 5.8 for details																																																																																																			
Test mode:	Refer to section 5.3 for details, and all channels have been tested, only shows the worst channel data in this report.																																																																																																			
Test results:	Passed																																																																																																			
Remark:	All three channels of all modulations have been tested, but only the worst channel and the worst modulation show in this test item.																																																																																																			

Measurement Data (the worst channel):

Band43

Reference Frequency: Lowest channel=3652.5MHz(5MHz for QPSK)			
Temperature (°C)	Power supplied (Vdc)	Frequency error	
		Hz	ppm
25	20	99	0.027105
	24	80	0.021903
	28	67	0.018344
Reference Frequency: Lowest channel=3655.0MHz(10MHz for QPSK)			
Temperature (°C)	Power supplied (Vdc)	Frequency error	
		Hz	ppm
25	20	89	0.024350
	24	78	0.021341
	28	90	0.024624
Reference Frequency: Lowest channel=3657.5MHz(15MHz for QPSK)			
Temperature (°C)	Power supplied (Vdc)	Frequency error	
		Hz	ppm
25	20	87	0.023787
	24	96	0.026247
	28	58	0.015858
Reference Frequency: Lowest channel=3660.0MHz(20MHz for QPSK)			
Temperature (°C)	Power supplied (Vdc)	Frequency error	
		Hz	ppm
25	20	99	0.027049
	24	71	0.019399
	28	80	0.021858

Reference Frequency: Lowest channel=3652.5MHz(5MHz for 16QAM)			
Temperature (°C)	Power supplied (Vdc)	Frequency error	
		Hz	ppm
25	20	95	0.026010
	24	88	0.024093
	28	64	0.017522
Reference Frequency: Lowest channel=3655.0MHz(10MHz for 16QAM)			
Temperature (°C)	Power supplied (Vdc)	Frequency error	
		Hz	ppm
25	20	84	0.022982
	24	96	0.026265
	28	73	0.019973
Reference Frequency: Lowest channel=3657.5MHz(15MHz for 16QAM)			
Temperature (°C)	Power supplied (Vdc)	Frequency error	
		Hz	ppm
25	20	78	0.021326
	24	90	0.024607
	28	48	0.013124
Reference Frequency: Lowest channel=3660.0MHz(20MHz for 16QAM)			
Temperature (°C)	Power supplied (Vdc)	Frequency error	
		Hz	ppm
25	20	98	0.026776
	24	85	0.023224
	28	60	0.016393