

FCC PART 90

TEST REPORT

For

Baicells Technologies Co., Ltd.

3F, Hui Yuan Development Building, No.1 Shangdi Information Industry Base, Haidian Dist.,
Beijing, China

FCC ID: 2AG32EG7035

Report Type: Original Report	Product Type: LTE Outdoor CPE
Test Engineer: <u> Joson Xiao </u>	<i>Joson Xiao</i>
Report Number: <u> RSZ160318009-00 </u>	
Report Date: <u> 2016-06-07 </u>	
Reviewed By: <u> Rocky Kang </u>	<i>Rocky Kang</i>
Prepared By: <u> RF Engineer </u>	
Prepared By: Bay Area Compliance Laboratories Corp. (Shenzhen) 6/F, the 3rd Phase of WanLi Industrial Building, ShiHua Road, FuTian Free Trade Zone Shenzhen, Guangdong, China Tel: +86-755-33320018 Fax: +86-755-33320008 www.baclcorp.com.cn	

Note: This test report is prepared for the customer shown above and for the equipment described herein. It may not be duplicated or used in part without prior written consent from Bay Area Compliance Laboratories Corp.

TABLE OF CONTENTS

GENERAL INFORMATION.....	3
PRODUCT DESCRIPTION FOR EQUIPMENT UNDER TEST (EUT)	3
OBJECTIVE	3
RELATED SUBMITTAL(S)/GRANT(S).....	3
TEST METHODOLOGY	3
TEST FACILITY	3
SYSTEM TEST CONFIGURATION.....	4
DESCRIPTION OF TEST CONFIGURATION	4
EQUIPMENT MODIFICATIONS	4
SUPPORT EQUIPMENT LIST AND DETAILS	4
EXTERNAL I/O CABLE.....	4
BLOCK DIAGRAM OF TEST SETUP	4
SUMMARY OF TEST RESULTS	5
FCC §2.1046, §90.1321(a) - RF OUTPUT POWER	6
APPLICABLE STANDARD	6
TEST PROCEDURE	6
TEST EQUIPMENT LIST AND DETAILS.....	6
TEST DATA	6
FCC §90.1321 (a) - PEAK POWER SPECTRAL DENSITY	8
APPLICABLE STANDARD	8
TEST PROCEDURE	8
TEST EQUIPMENT LIST AND DETAILS.....	8
TEST DATA	9
FCC §2.1049 & §90.209 – OCCUPIED BANDWIDTH	23
APPLICABLE STANDARD	23
TEST PROCEDURE	23
TEST EQUIPMENT LIST AND DETAILS.....	23
TEST DATA	23
FCC §2.1051 & §90.1323(a) - SPURIOUS EMISSIONS AT ANTENNA TERMINALS.....	29
APPLICABLE STANDARD	29
TEST PROCEDURE	29
TEST EQUIPMENT LIST AND DETAILS.....	29
TEST DATA	30
FCC §2.1053 - RADIATED SPURIOUS EMISSIONS	51
APPLICABLE STANDARD	51
TEST PROCEDURE	51
TEST EQUIPMENT LIST AND DETAILS.....	51
TEST DATA	52
FCC §2.1055 & §90.213- FREQUENCY STABILITY.....	53
APPLICABLE STANDARD	53
TEST PROCEDURE	53
TEST EQUIPMENT LIST AND DETAILS.....	53
TEST DATA	53

GENERAL INFORMATION

Product Description for Equipment under Test (EUT)

The *Baicells Technologies Co., Ltd.*'s product, model number: *EG7035(FCC ID: 2AG32EG7035)* or the "EUT" in this report was a *LTE Outdoor CPE*, which was measured approximately: 280 mm (L) x280 mm (W) x 120 mm (H), rated with input voltage: DC 12 V from adapter.

** All measurement and test data in this report was gathered from production sample serial number: 1601691 (Assigned by BAACL, Shenzhen). The EUT supplied by the applicant was received on 2016-03-18.*

Objective

This test report is prepared on behalf of *Baicells Technologies Co., Ltd.* in accordance with Part 2, and Part 90 of the Federal Communication Commissions rules.

Related Submittal(s)/Grant(s)

No related submittal.

Test Methodology

All tests and measurements indicated in this document were performed in accordance with the Code of federal Regulations Title 47 Part 2, Sub-part Z as well as the following individual parts:

Part 90 – Wireless Broadband Services in the 3650-3700 MHz Band

Applicable Standards: TIA 603-D and ANSI 63.4-2014.

All emissions measurement was performed and Bay Area Compliance Laboratories Corp. (Shenzhen). The radiated testing was performed at an antenna-to-EUT distance of 3 meters.

Measurement uncertainty with radiated emission is 5.91 dB for 30MHz-1GHz.and 4.92 dB for above 1GHz, 1.95dB for conducted measurement.

Test Facility

The test site used by Bay Area Compliance Laboratories Corp. (Shenzhen) to collect test data is located on the 6/F, the 3rd Phase of WanLi Industrial Building, ShiHua Road, FuTian Free Trade Zone Shenzhen, Guangdong, China.

Test site at Bay Area Compliance Laboratories Corp. (Shenzhen) has been fully described in reports submitted to the Federal Communication Commission (FCC). The details of these reports have been found to be in compliance with the requirements of Section 2.948 of the FCC Rules on October 31, 2013. The facility also complies with the radiated and AC line conducted test site criteria set forth in ANSI C63.4-2014.

The Federal Communications Commission has the reports on file and is listed under FCC Registration No.: 382179. The test site has been approved by the FCC for public use and is listed in the FCC Public Access Link (PAL) database.

SYSTEM TEST CONFIGURATION

Description of Test Configuration

The system was configured for testing in a test mode which has been done in the factory.

Equipment Modifications

No modification was made to the EUT tested.

Support Equipment List and Details

Manufacturer	Description	Model	Serial Number
Rohde & Schwarz	Wideband Radio Communication Tester	CMW500	114772

External I/O Cable

Cable Description	Length (m)	From Port	To
Un-shielding Un-detachable AC cable	1.0	Adapter	Mains
Un-shielding Un-detachable DC cable	1.5	Adapter	POE
Un-shielding detachable RJ45 cable	1.5	POE	EUT

Block Diagram of Test Setup

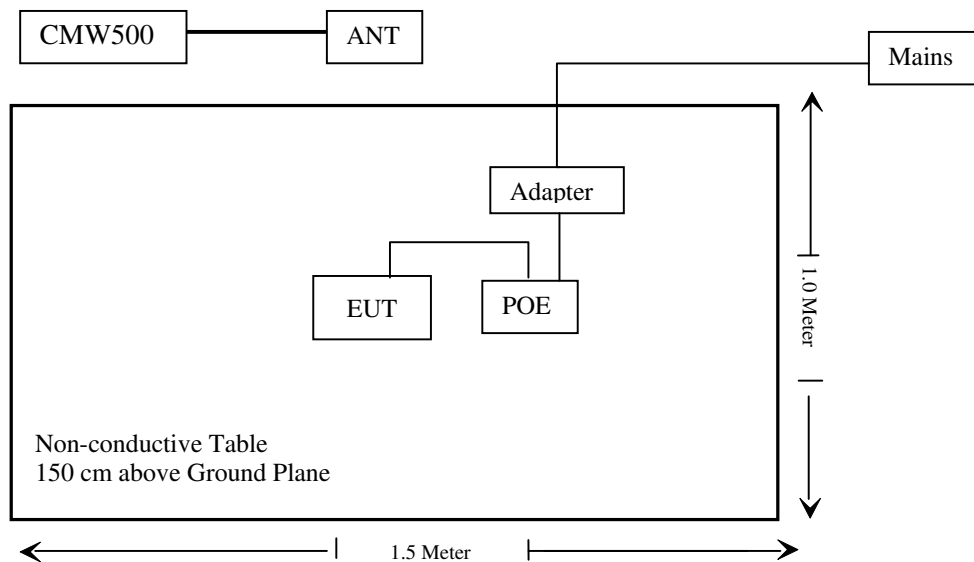

SUMMARY OF TEST RESULTS

FCC Rules	Description of Test	Results
§1.1307 (b)(1), §2.1091	Maximum Permissible Exposure (MPE)	Compliance
§2.1046; §90.1321(a); §90.1321(c)	RF Output Power	Compliance
§90.1321(a); §90.1321(a)	Peak Power Spectral Density	Compliance
§2.1049; §90.209	Occupied Bandwidth	Compliance
§2.1051; §90.1323(a)	Spurious Emission at Antenna Terminal	Compliance
§2.1053	Spurious Radiated Emissions	Compliance
§2.1055; §90.213	Frequency Stability	Compliance

FCC §2.1046, §90.1321(a) - RF OUTPUT POWER

Applicable Standard

FCC §2.1046 and §90.1321

Limit

According to FCC §90.1321:

(a) Base and fixed stations are limited to 25 watts/25 MHz equivalent isotropically radiated power (EIRP). In any event, the peak EIRP power density shall not exceed 1 Watt in any one-megahertz slice of spectrum.

Test Procedure

The EUT was connected to a CMW500 through a attenuator,the EUT power was adjusted to produce maximum output power as specified in the owner’s manual,measurements were performed at the low,mid and high channels for each of the EUT’s bandwidths and modulations.

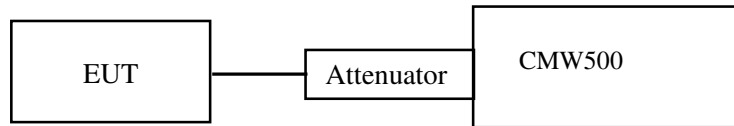

Test Equipment List and Details

Manufacturer	Description	Model	Serial Number	Calibration Date	Calibration Due Date
Rohde & Schwarz	Wideband Radio Communication Tester	CMW500	114772	2015-11-15	2016-11-14
Ducommun technologies	RF Cable	RG-214	3	2015-06-15	2016-06-15
WEINSCHEL	3dB Attenuator	5321	AU0709	2015-06-18	2016-06-18

* **Statement of Traceability:** Bay Area Compliance Laboratories Corp. (Shenzhen) attests that all calibrations have been performed in accordance to requirements, traceable to National Primary Standards and International System of Units (SI).

Test Data

Environmental Conditions

Temperature:	23 °C
Relative Humidity:	50 %
ATM Pressure:	101.0 kPa

The testing was performed by Joson Xiao on 2016-04-22.

Test Mode: Transmitting

Test Result: Compliance. Please refer to following table.

LTE Band: 3650-3700MHz-full RB

Modulation	Frequency (MHz)	Output Power (dBm)	Antenna gain (dBi)	EIRP (dBm)	Limited (dBm)
QPSK(5MHz)	3652.5	16.88	19.5	36.38	37.01
	3675	16.78	19.5	36.28	
	3697.5	16.50	19.5	36.00	
16QAM(5MHz)	3652.5	17.02	19.5	36.52	
	3675	16.92	19.5	36.42	
	3697.5	16.54	19.5	36.04	
QPSK(10MHz)	3655	16.85	19.5	36.35	40.02
	3675	16.79	19.5	36.29	
	3695	16.52	19.5	36.02	
16QAM(10MHz)	3655	16.92	19.5	36.42	
	3675	16.82	19.5	36.32	
	3695	16.61	19.5	36.11	
QPSK(15MHz)	3657.5	16.67	19.5	36.17	41.78
	3675	16.53	19.5	36.03	
	3692.5	16.35	19.5	35.85	
16QAM(15MHz)	3657.5	16.73	19.5	36.23	
	3675	16.56	19.5	36.06	
	3692.5	16.36	19.5	35.86	
QPSK(20MHz)	3660	16.19	19.5	35.69	43.03
	3675	16.09	19.5	35.59	
	3690	15.95	19.5	35.45	
16QAM(20MHz)	3660	16.21	19.5	35.71	
	3675	16.11	19.5	35.61	
	3690	15.93	19.5	35.43	

Note: limit = 44dBm + 10Log (Bandwidth/25)

Eg: For 10 MHz Bandwidth, the limit =44dBm + 10Log (10/25) = 40.02 dBm

FCC §90.1321 (a) - PEAK POWER SPECTRAL DENSITY

Applicable Standard

FCC §90.1321 (a);

Limit

According to FCC §90.1321:

(a) Base and fixed stations are limited to 25 watts/25 MHz equivalent isotropically radiated power (EIRP). In any event, the peak EIRP power density shall not exceed 1 Watt in any one-megahertz slice of spectrum.

Test Procedure

The EUT was connected to a CMW500 & signal analyzer through a splitter, the EUT power was adjusted to produce maximum output power as specified in the owner’s manual, measurements were performed at the low, mid and high channels for each of the EUT’s bandwidths and modulations.

The resolution bandwidth of the spectrum analyzer was set at 1MHz.

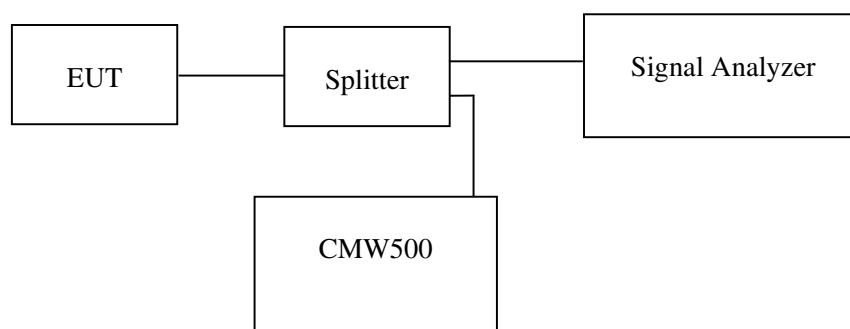

Test Equipment List and Details

Manufacturer	Description	Model	Serial Number	Calibration Date	Calibration Due Date
Rohde & Schwarz	Signal Analyzer	FSIQ26	8386001028	2015-11-12	2016-11-12
Rohde & Schwarz	Wideband Radio Communication Tester	CMW500	114772	2015-11-15	2016-11-14
Ducommun technologies	RF Cable	RG-214	3	2015-06-15	2016-06-15
WEINSCHTEL	3dB Attenuator	5321	AU0709	2015-06-18	2016-06-18

* **Statement of Traceability:** Bay Area Compliance Laboratories Corp. (Shenzhen) attests that all calibrations have been performed in accordance to requirements, traceable to National Primary Standards and International System of Units (SI).

Test Data

Environmental Conditions

Temperature:	22 -27°C
Relative Humidity:	52-55 %
ATM Pressure:	100.5-101.0 kPa

The testing was performed by Joson Xiao from 2016-03-28 to 2016-05-28.

Test Mode: Transmitting

Result: Compliance.

LTE Band: 3650-3700MHz

Modulation	Frequency (MHz)	Power Density (dBm/MHz)	Antenna Gain (dBi)	EIRP Power Density (dBm/MHz)	Limit (dBm/MHz)
QPSK(5MHz)	3652.5	7.98	19.5	27.48	30
	3675	9.36	19.5	28.86	
	3697.5	7.78	19.5	27.28	
16QAM(5MHz)	3652.5	8.08	19.5	27.58	
	3675	9.58	19.5	29.08	
	3697.5	8.53	19.5	28.03	
QPSK(10MHz)	3655	5.80	19.5	25.30	
	3675	6.54	19.5	26.04	
	3695	5.56	19.5	25.06	
16QAM(10MHz)	3655	5.81	19.5	25.31	
	3675	6.29	19.5	25.79	
	3695	5.87	19.5	25.37	
QPSK(15MHz)	3657.5	3.64	19.5	23.14	
	3675	2.88	19.5	22.38	
	3692.5	3.75	19.5	23.25	
16QAM(15MHz)	3657.5	3.81	19.5	23.31	
	3675	2.79	19.5	22.29	
	3692.5	3.73	19.5	23.23	
QPSK(20MHz)	3660	2.06	19.5	21.56	
	3675	2.72	19.5	22.22	
	3690	1.94	19.5	21.44	
16QAM(20MHz)	3660	2.26	19.5	21.76	
	3675	2.85	19.5	22.35	
	3690	1.76	19.5	21.26	

Please refer to the following plots

QPSK (5MHz), Low Channel

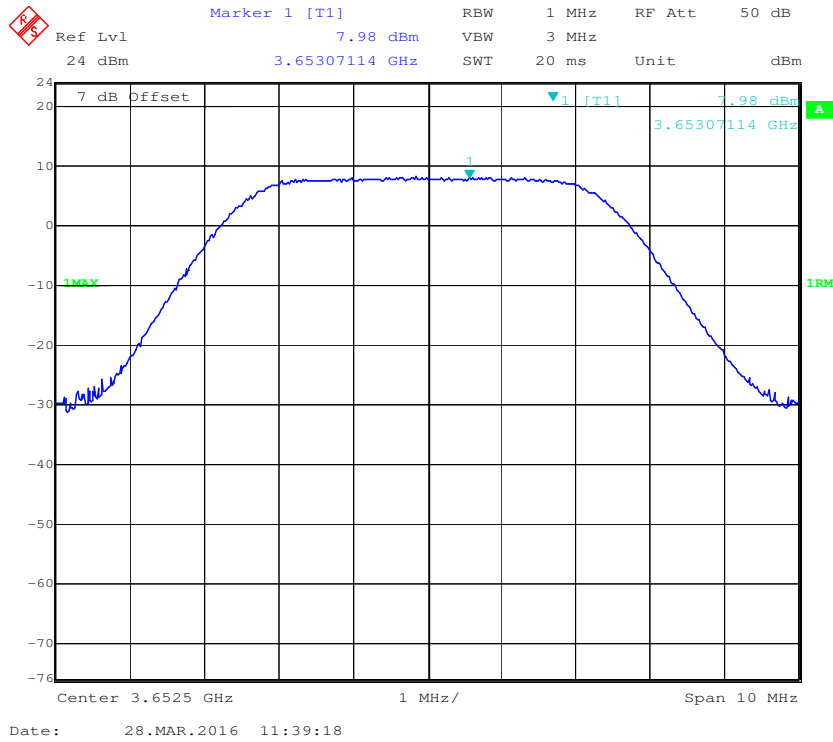

QPSK (5MHz), Middle Channel

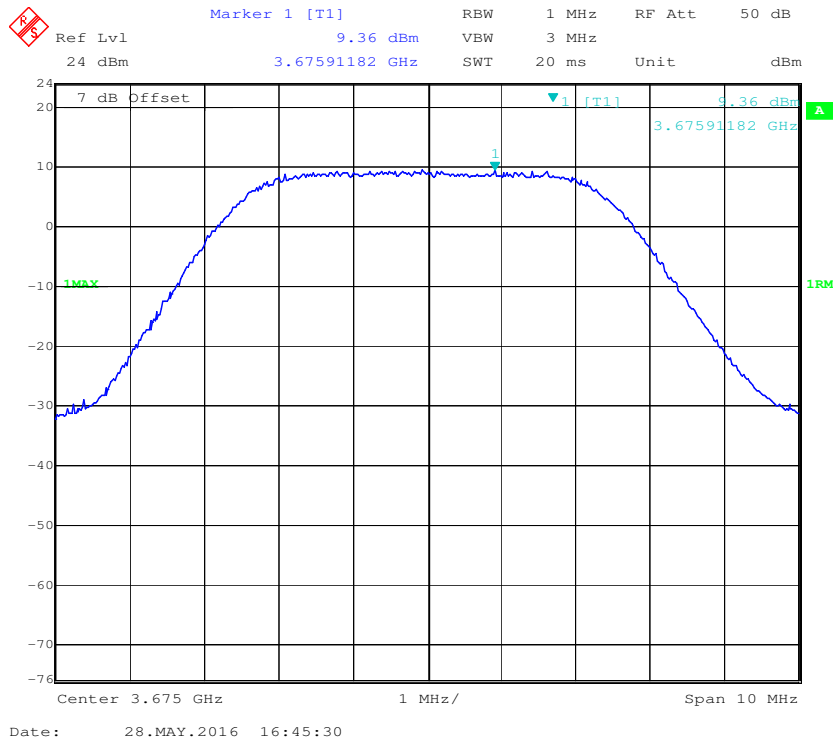

QPSK (5MHz), High Channel

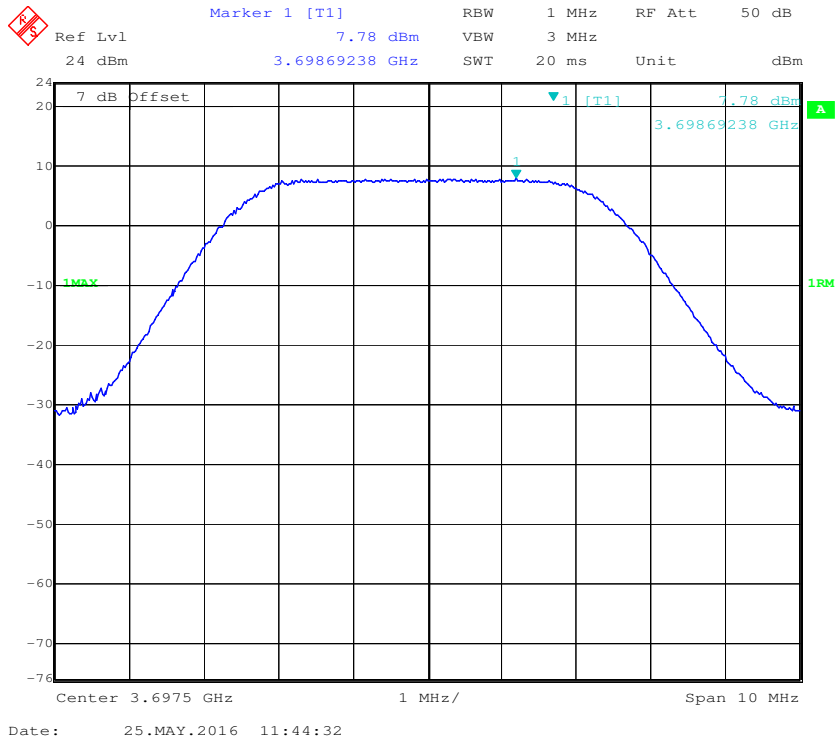

16QAM (5MHz), Low Channel

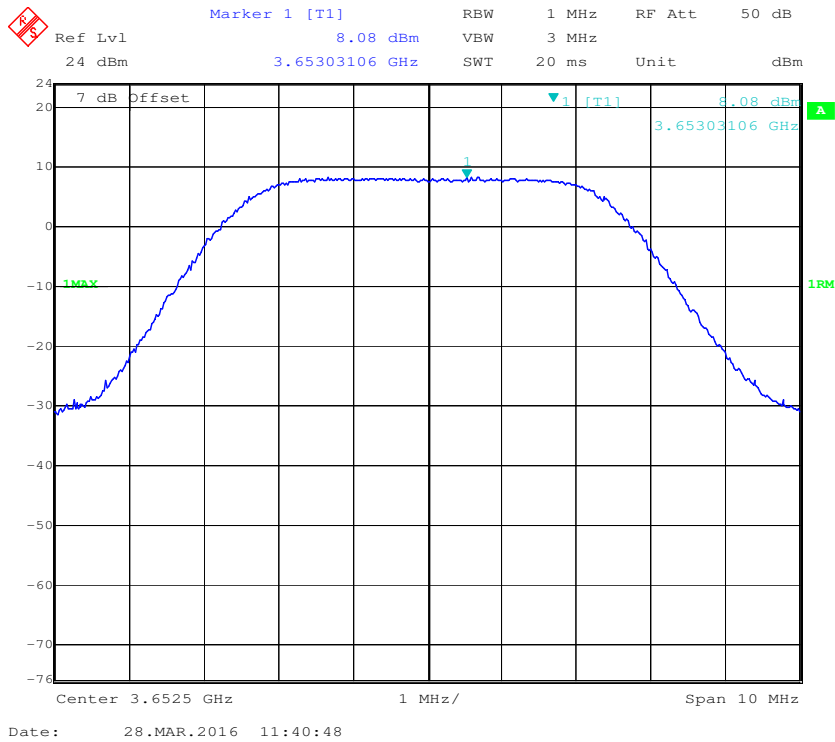

16QAM (5MHz), Middle Channel

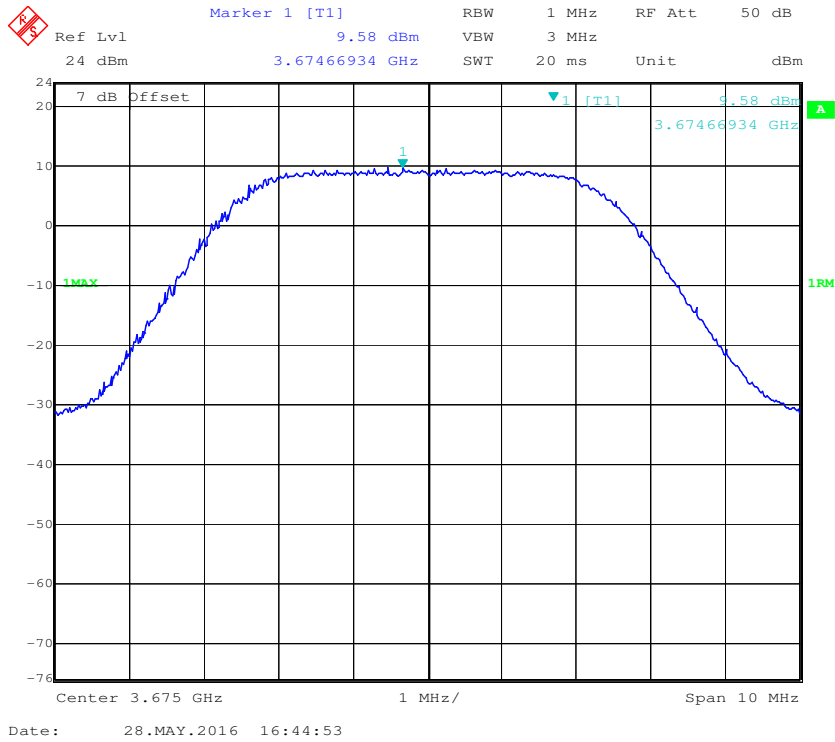

16QAM (5MHz), High Channel

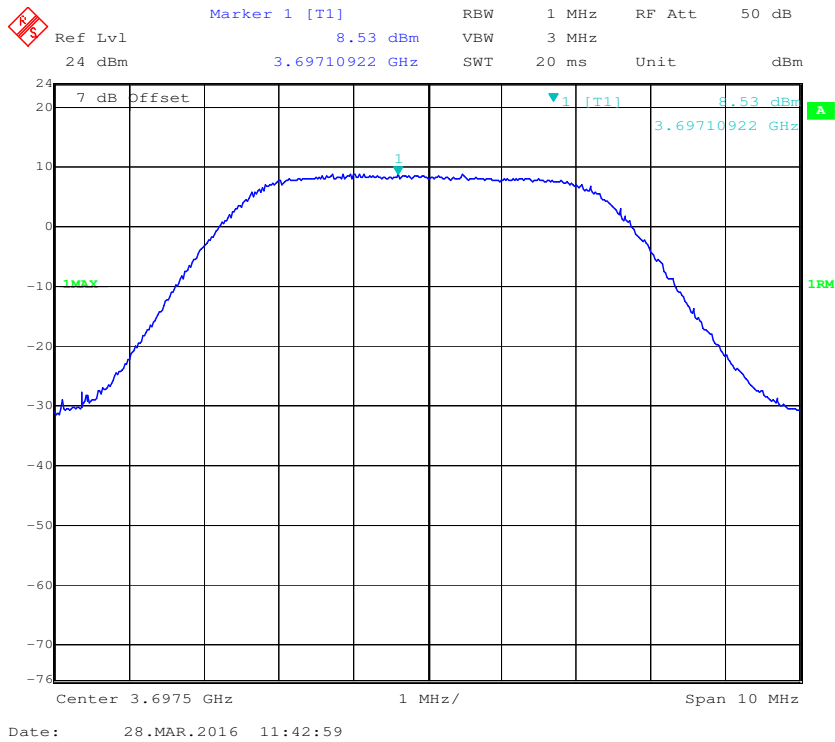

QPSK (10MHz), Low Channel

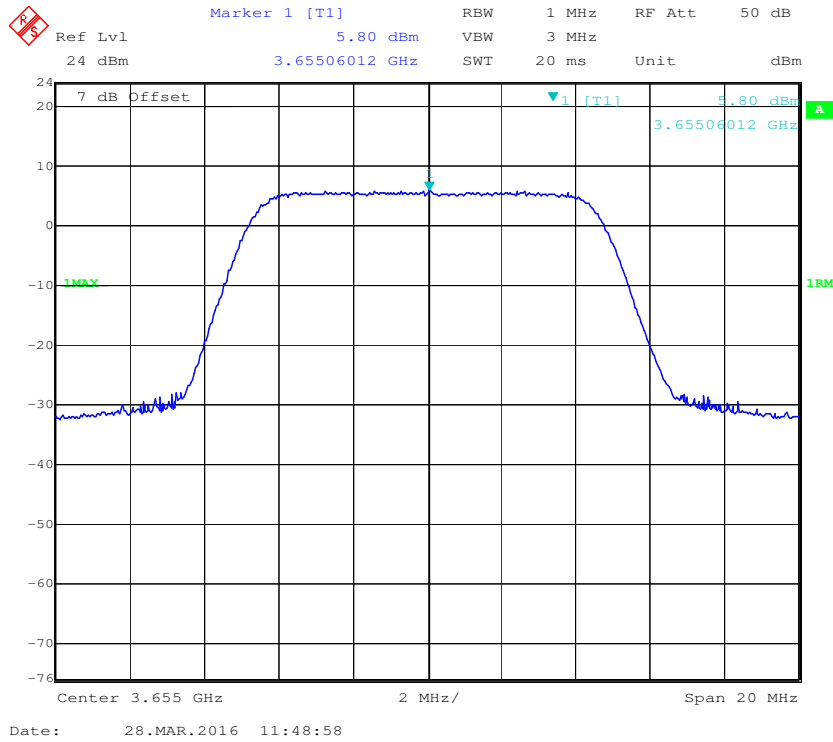

QPSK (10MHz), Middle Channel

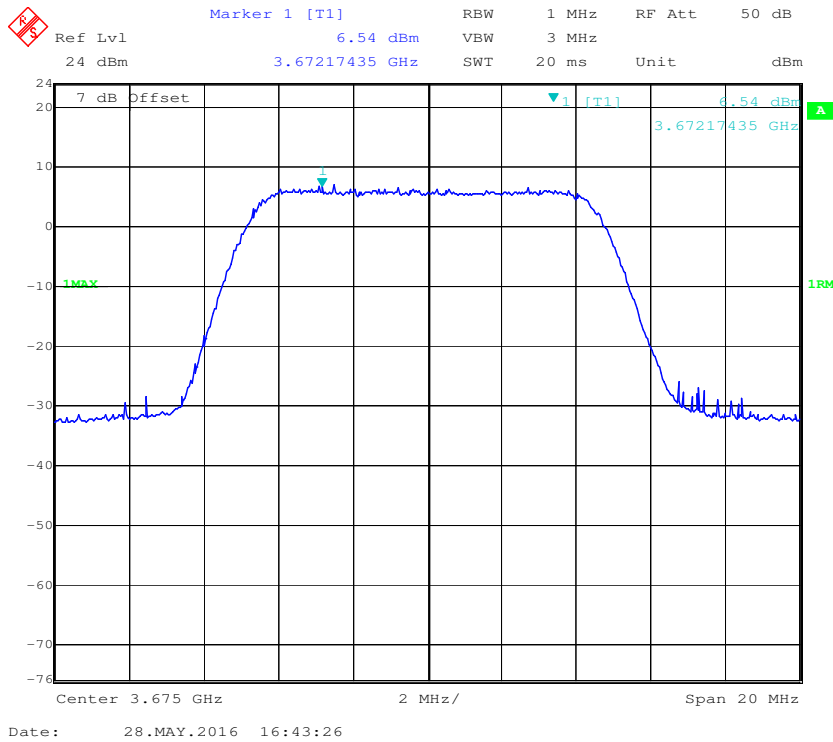

QPSK (10MHz), High Channel

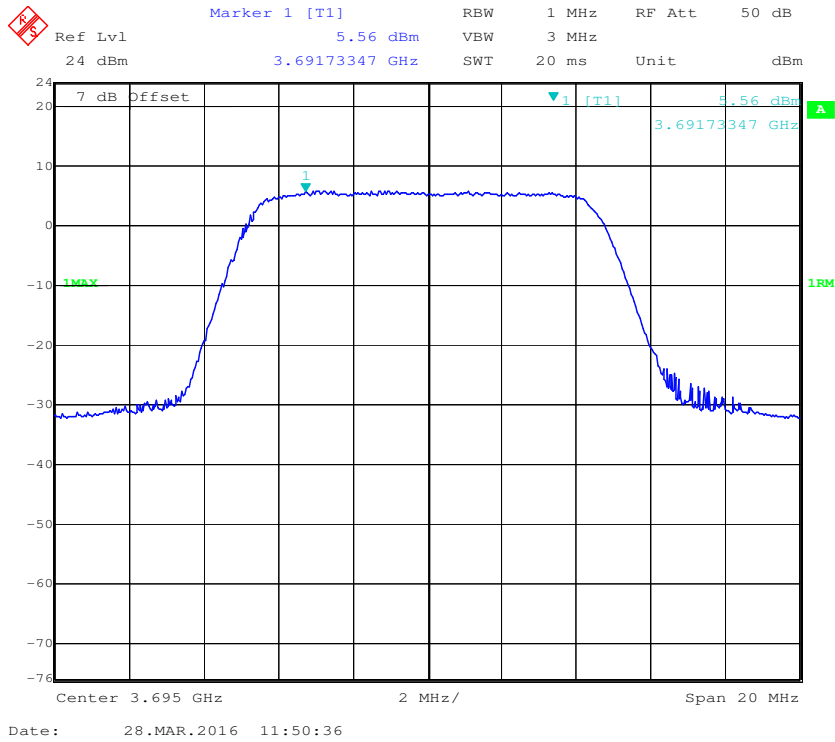

16QAM (10MHz), Low Channel

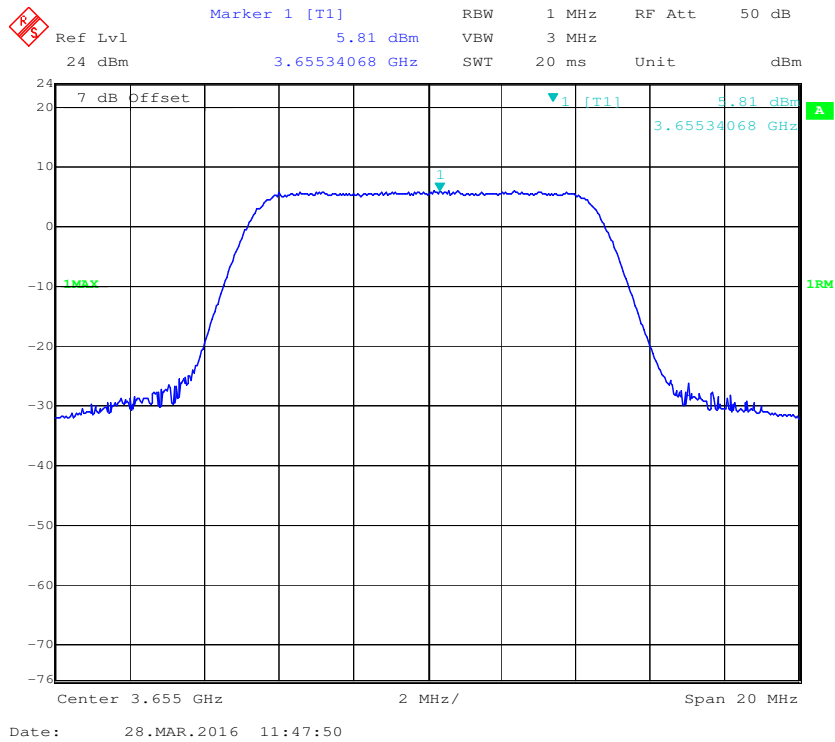

16QAM (10MHz), Middle Channel

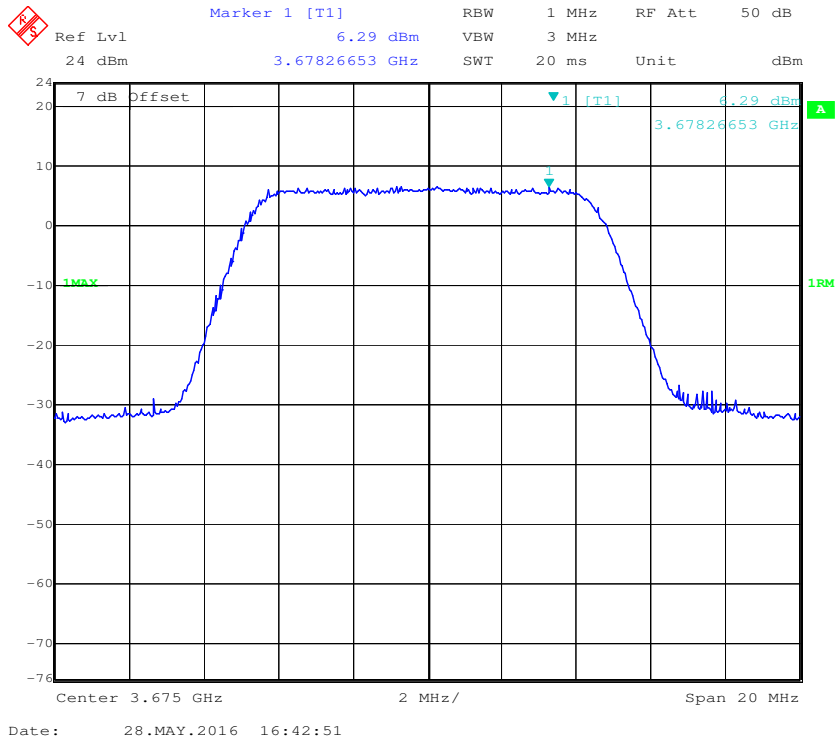

16QAM (10MHz), High Channel



QPSK (15MHz), Low Channel

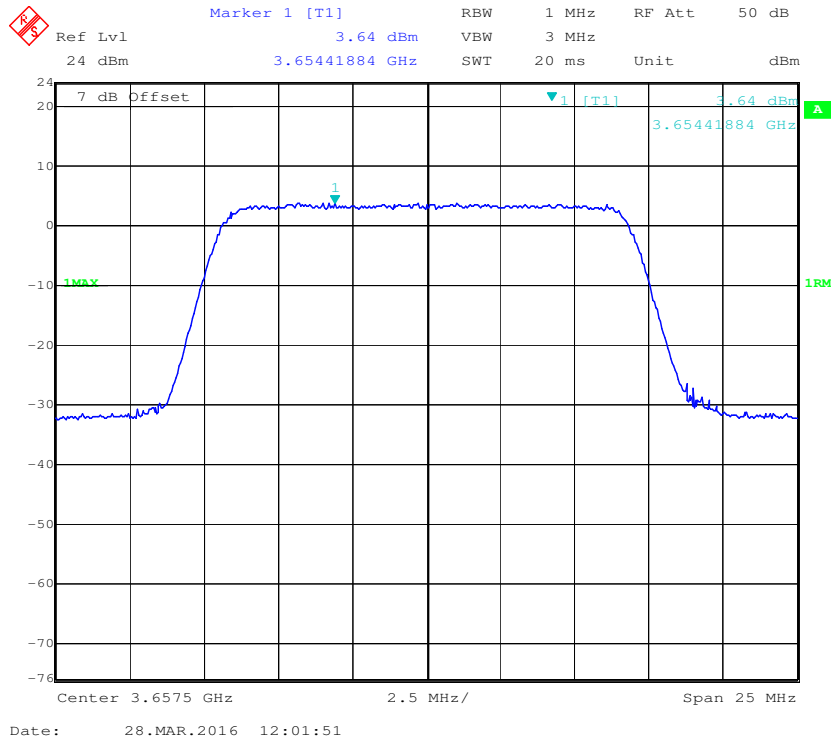

QPSK (15MHz), Middle Channel

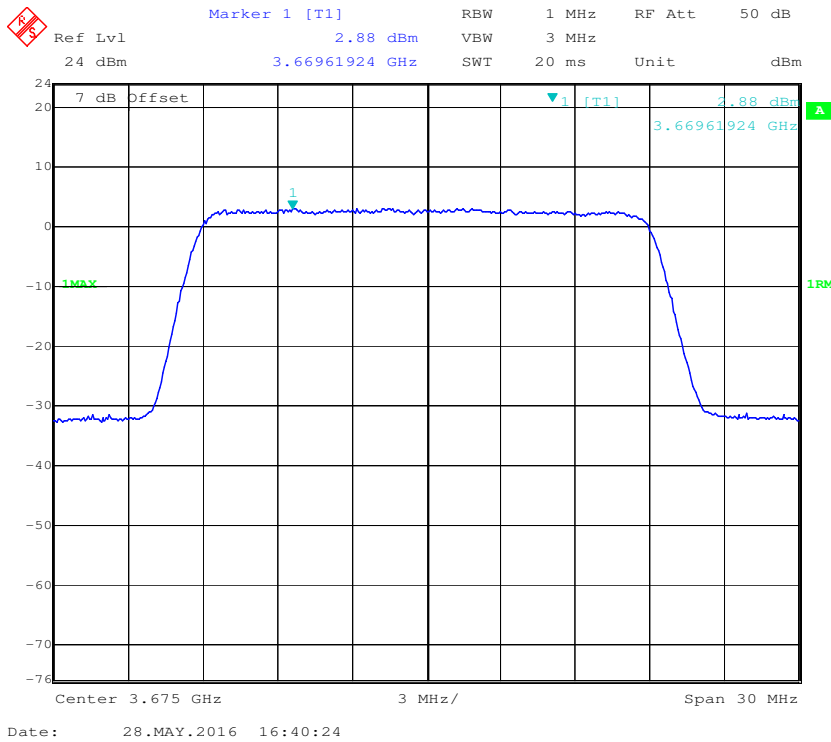

QPSK (15MHz), High Channel

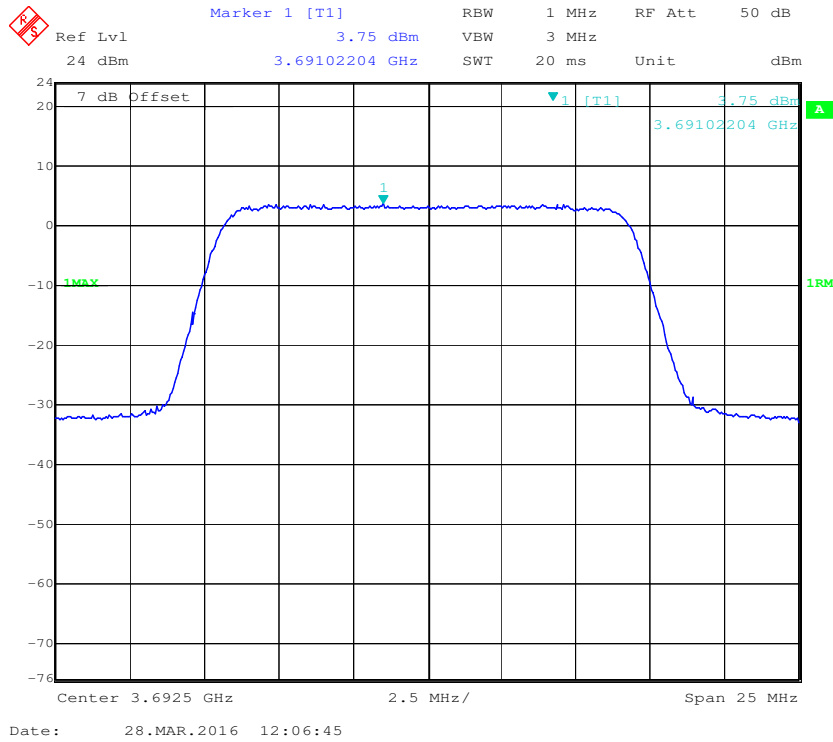

16QAM (15MHz), Low Channel

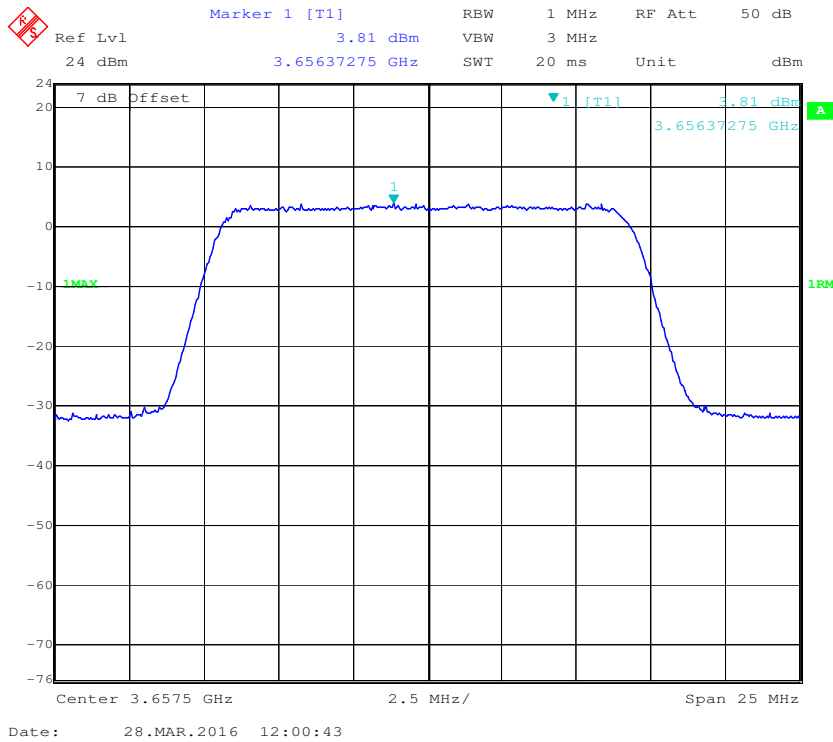

16QAM (15MHz), Middle Channel

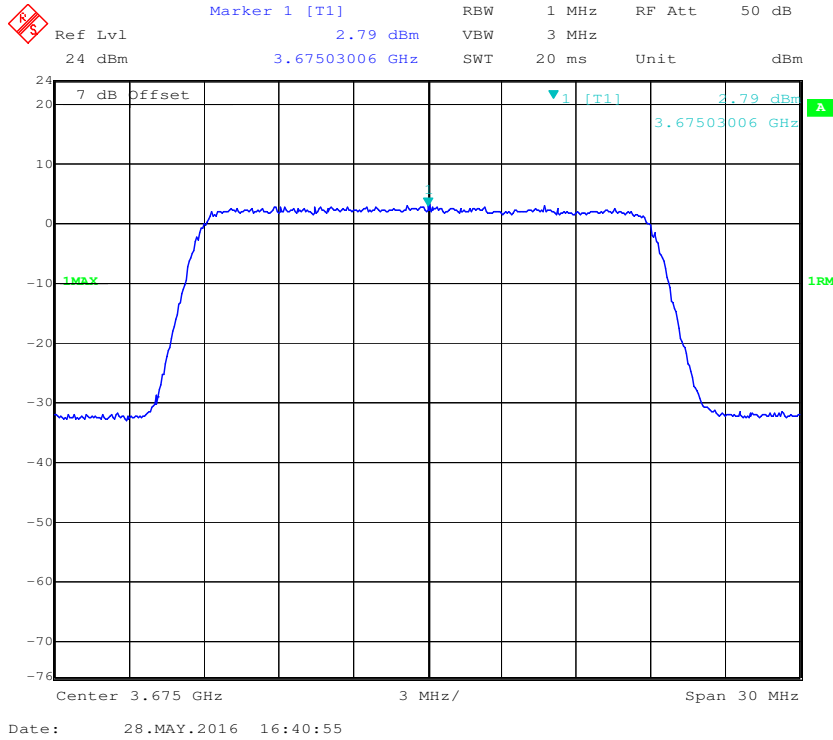

16QAM (15MHz), HighChannel

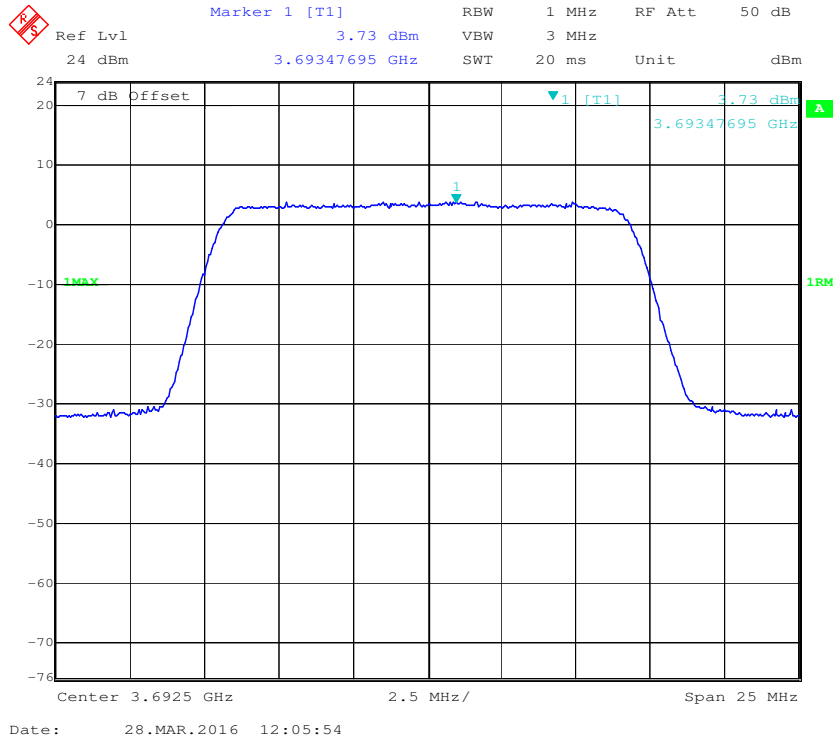

QPSK (20MHz), Low Channel

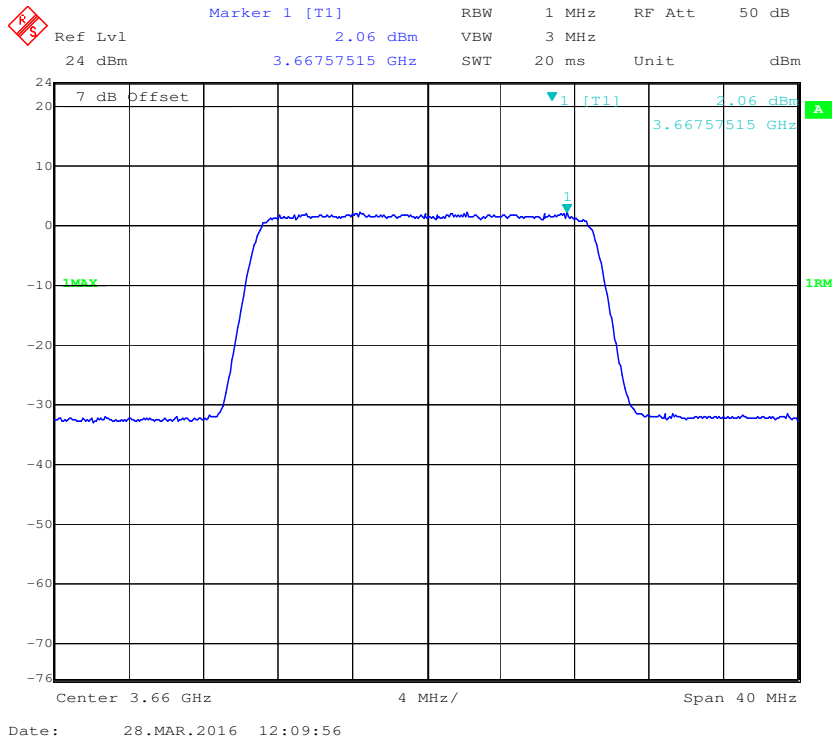

QPSK (20MHz), Middle Channel

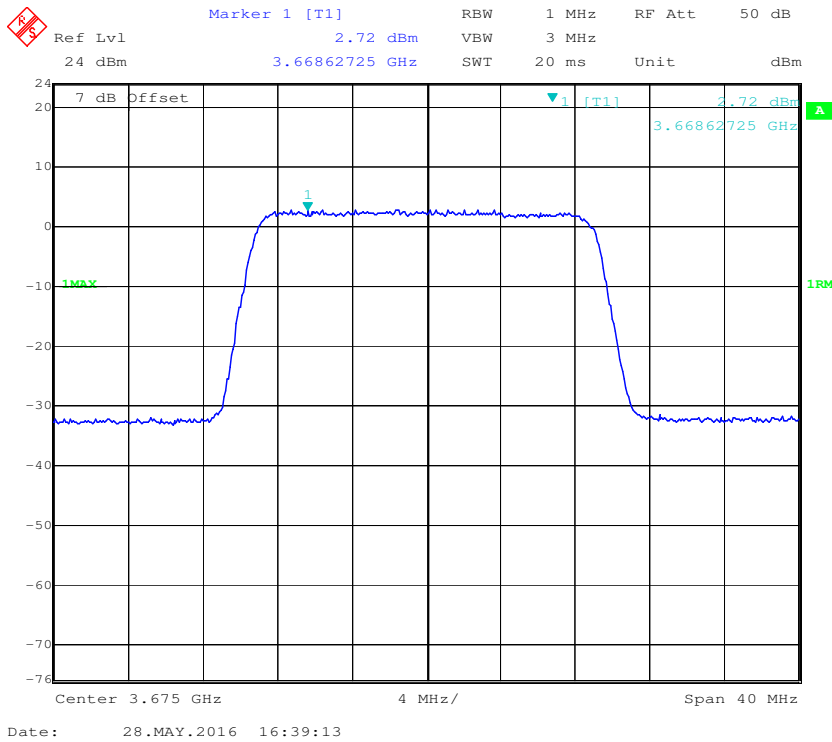

QPSK (20MHz), High Channel

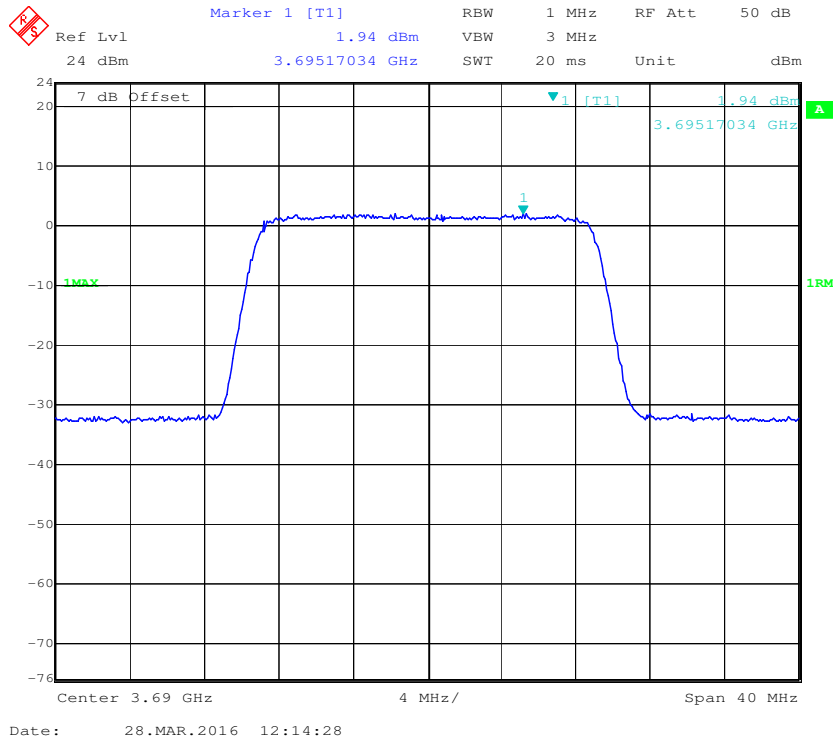

16QAM (20MHz), Low Channel

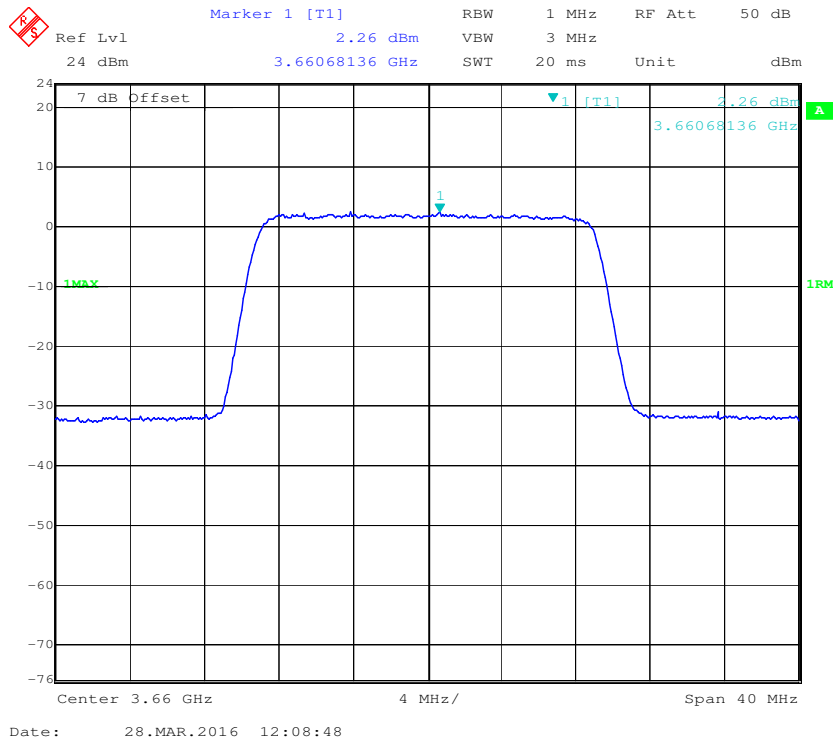

16QAM (20MHz), Middle Channel

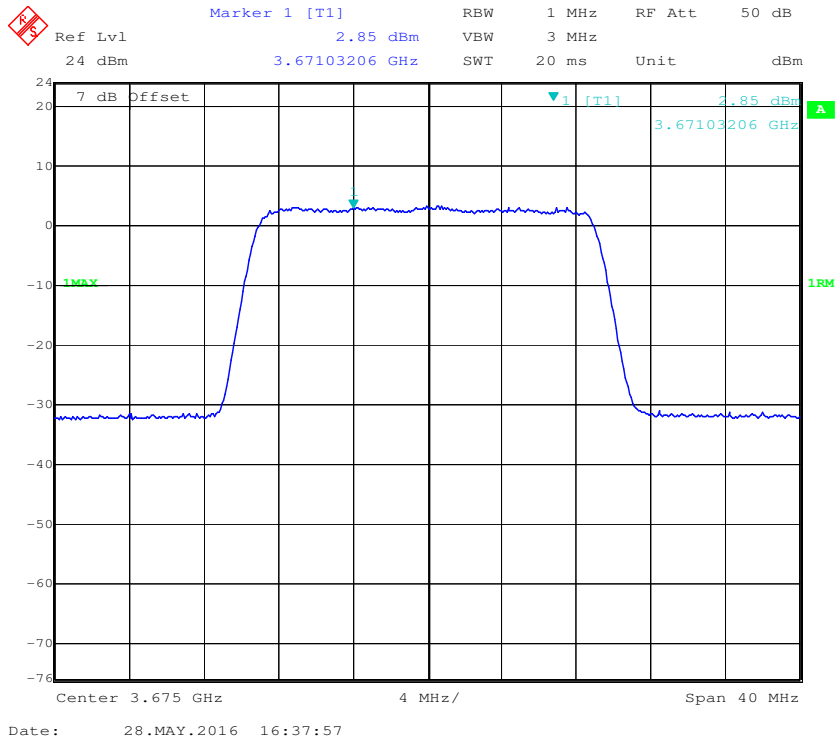

16QAM (20MHz), High Channel

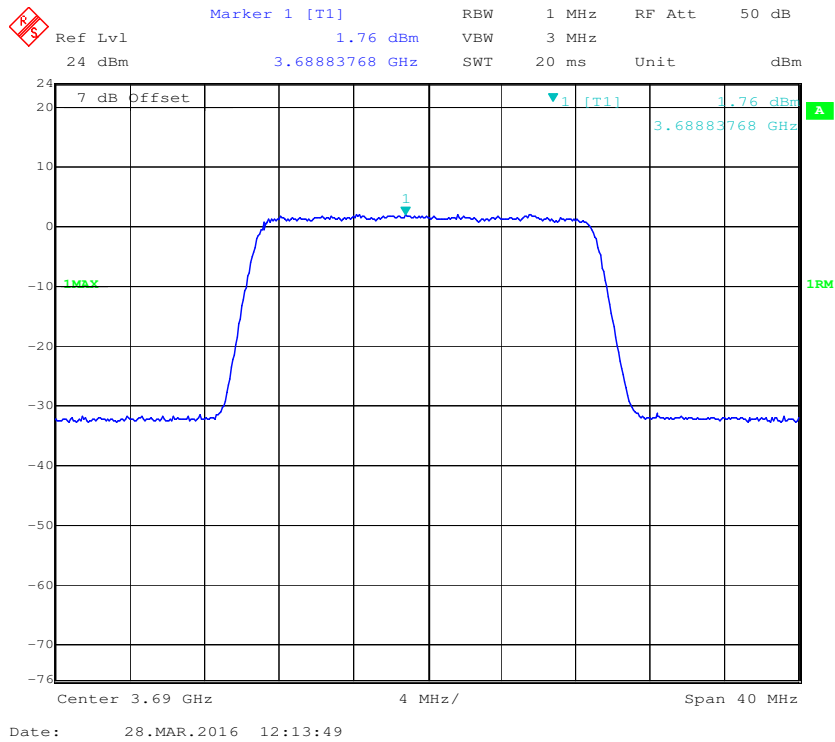

FCC §2.1049 & §90.209 – OCCUPIED BANDWIDTH

Applicable Standard

FCC §2.1049 and §90.209

Test Procedure

The EUT was connected to a CMW500 & signal analyzer through a splitter, the EUT power was adjusted to produce maximum output power as specified in the owner’s manual, measurements were performed at middle channel for each of the EUT’s bandwidths and modulations.

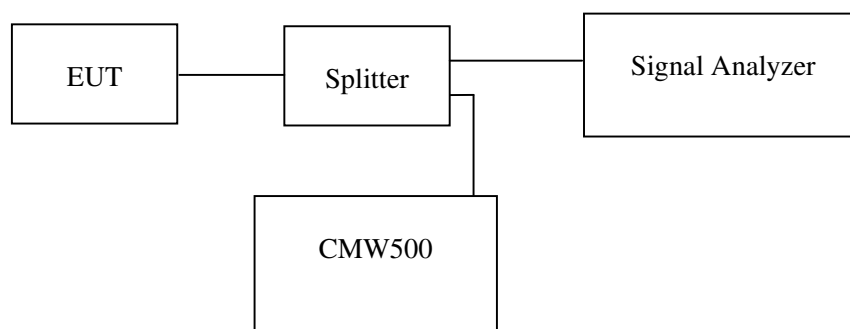

Test Equipment List and Details

Manufacturer	Description	Model No.	Serial No.	Calibration Date	Calibration Due Date
Rohde & Schwarz	Signal Analyzer	FSIQ26	8386001028	2015-11-12	2016-11-12
Rohde & Schwarz	Wideband Radio Communication Tester	CMW500	114772	2015-11-15	2016-11-14
Ducommun technologies	RF Cable	RG-214	3	2015-06-15	2016-06-15
WEINSCHTEL	3dB Attenuator	5321	AU0709	2015-06-18	2016-06-18

* **Statement of Traceability:** Bay Area Compliance Laboratories Corp. (Shenzhen) attests that all calibrations have been performed in accordance to requirements, traceable to National Primary Standards and International System of Units (SI).

Test Data

Environmental Conditions

Temperature:	27°C
Relative Humidity:	55 %
ATM Pressure:	101.0 kPa

The testing was performed by JASON XIAO on 2016-05-28.

LTE Band: 3650-3700MHz

Modulation	Frequency (MHz)	99% Occupied Bandwidth (MHz)	26 dB Emissions Bandwidth (MHz)
5M	QPSK	4.53	5.55
	16QAM	4.53	5.47
10M	QPSK	8.98	10.06
	16QAM	8.98	10.34
15M	QPSK	13.59	14.85
	16QAM	13.59	14.73
20M	QPSK	17.96	19.24
	16QAM	18.04	19.32

Please refer to the following plots:

QPSK (5MHz), Middle Channel

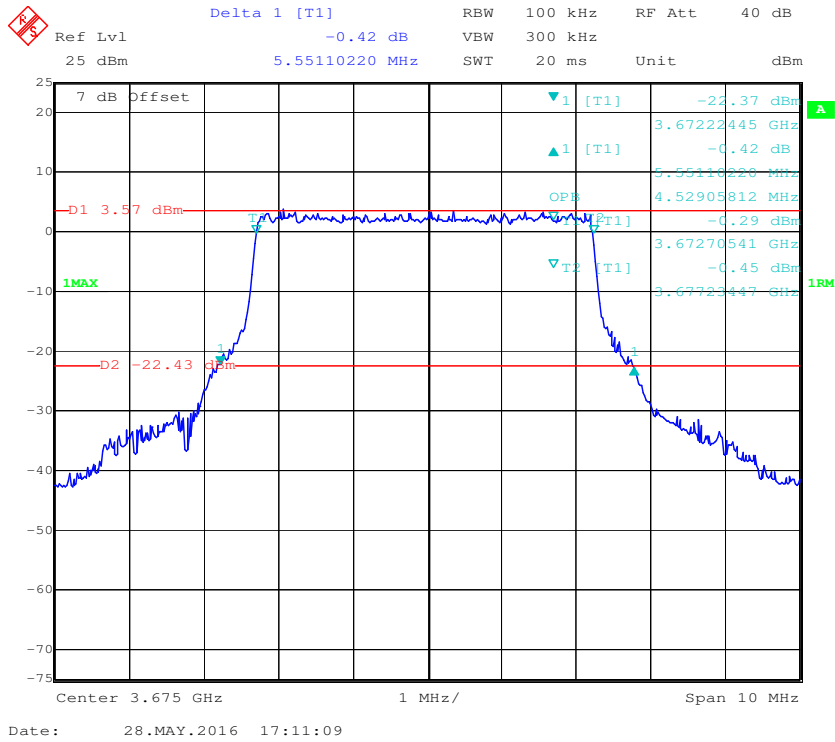

16QAM (5MHz), Middle Channel

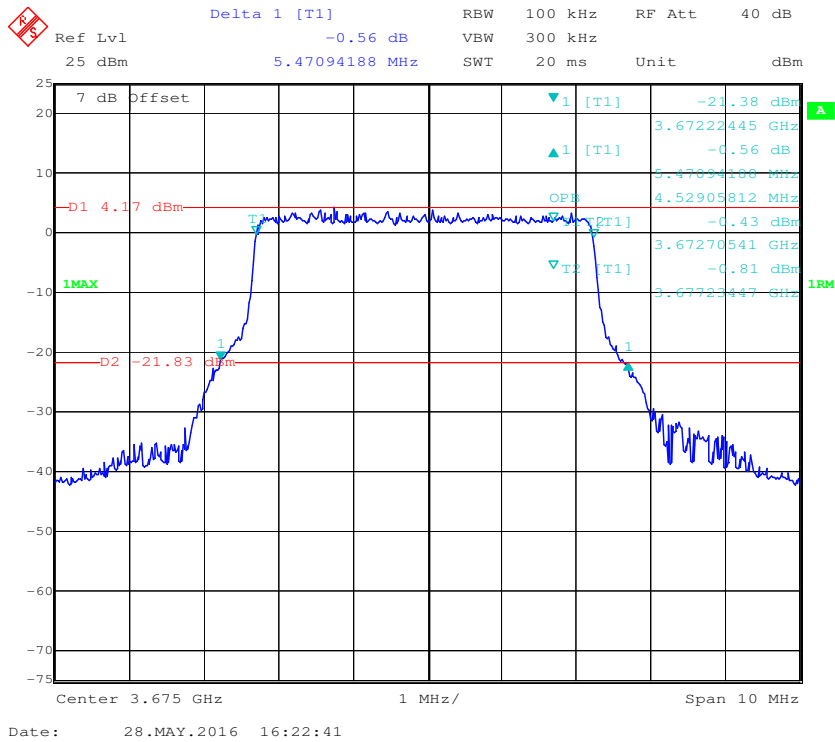

QPSK (10MHz), Middle Channel

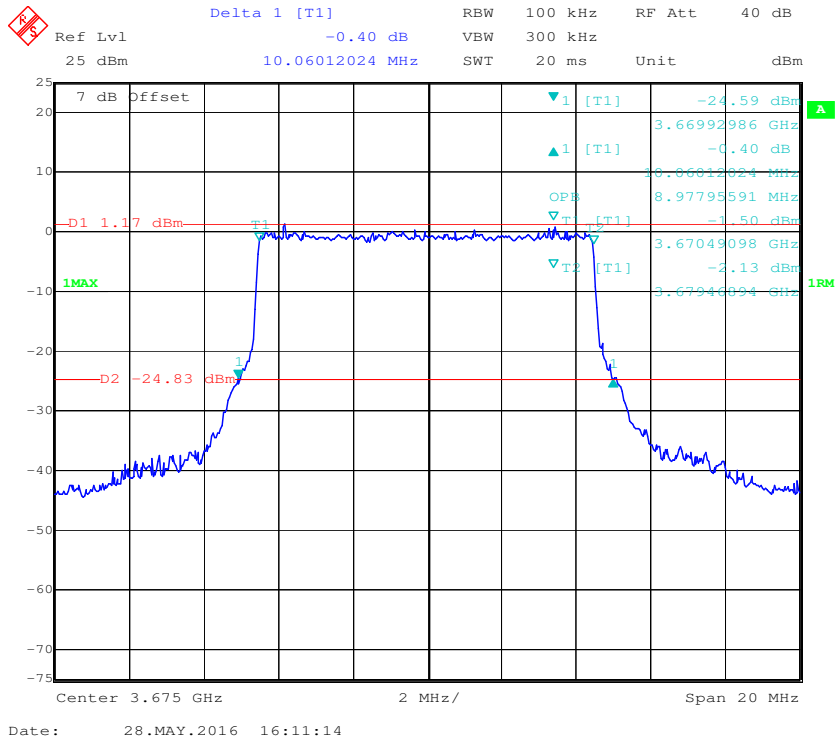

16QAM (10MHz), Middle Channel

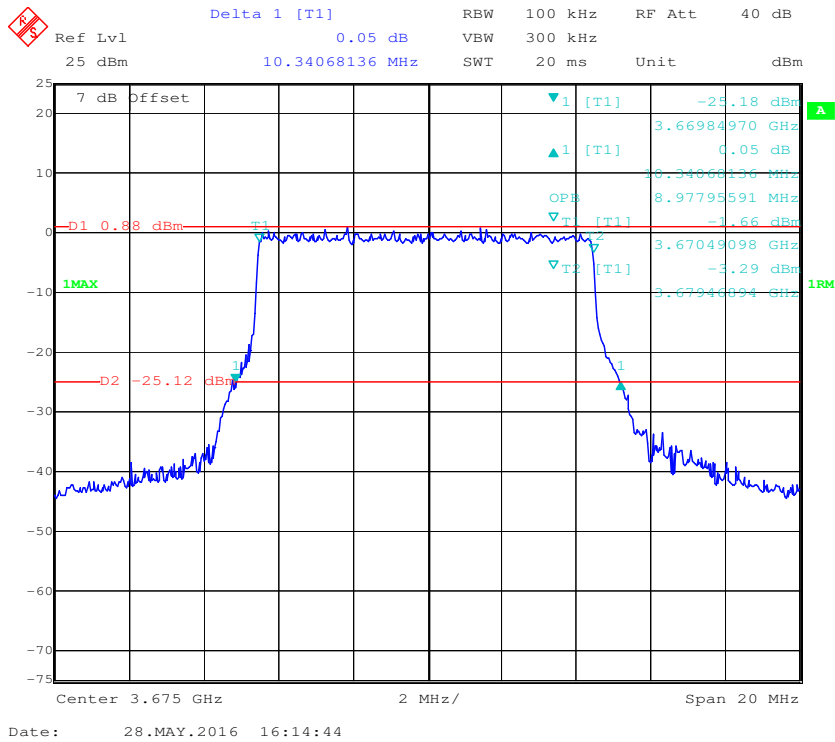

QPSK (15MHz), Middle Channel

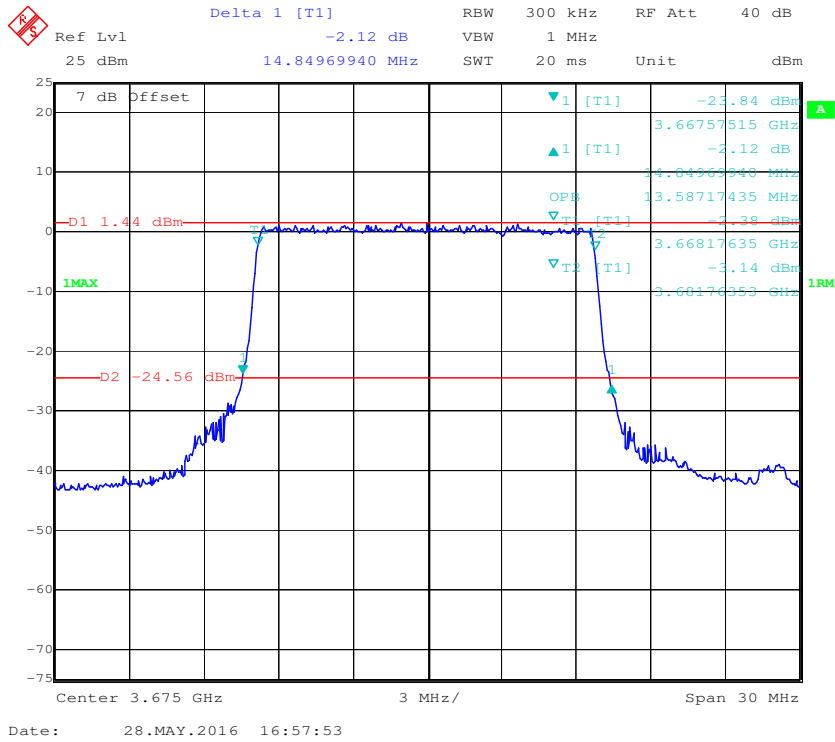

16QAM (15MHz), Middle Channel

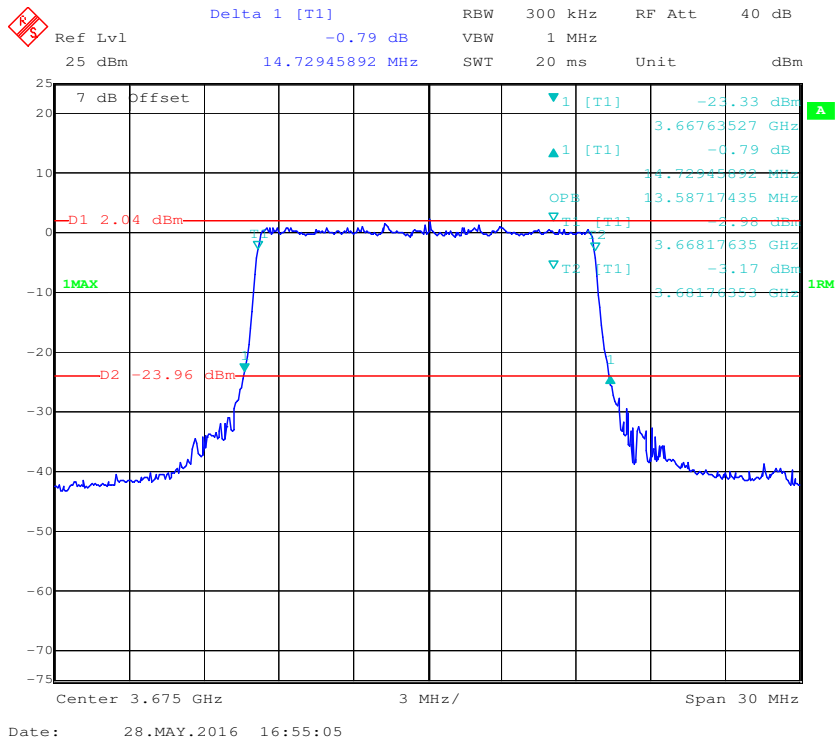

QPSK (20MHz), Middle Channel

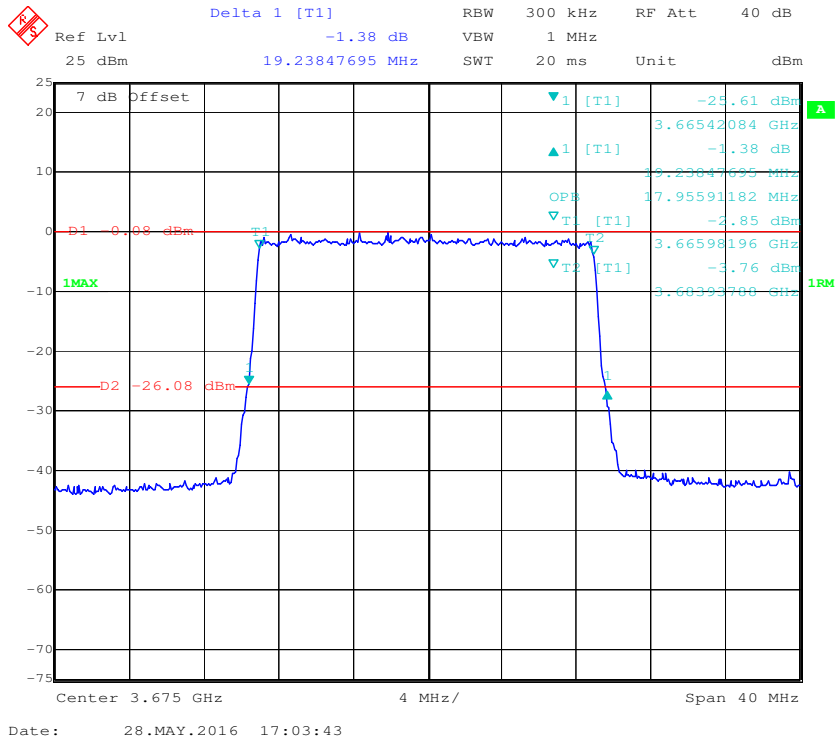

16QAM (20MHz), Middle Channel

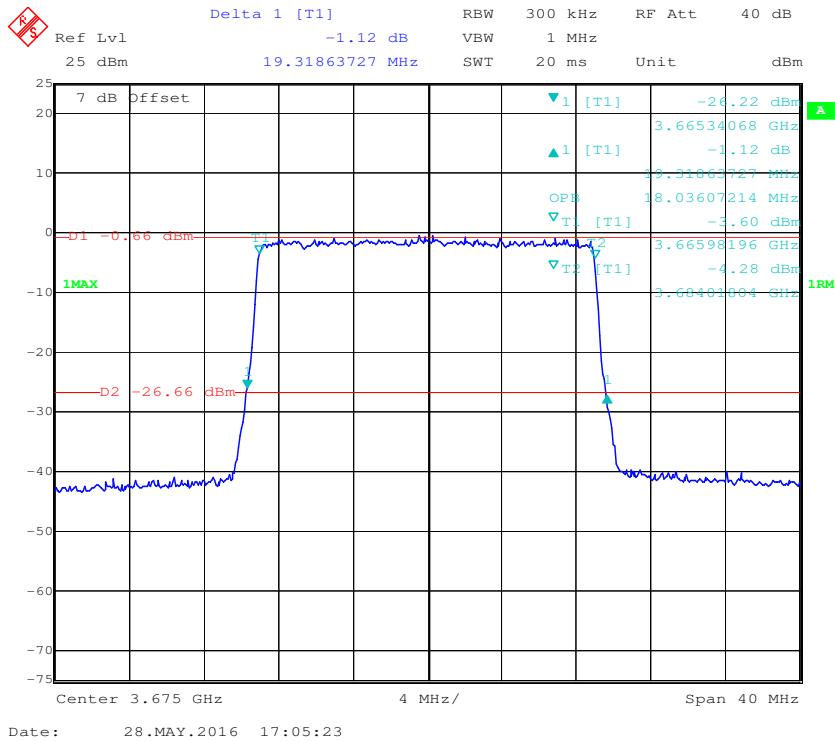

FCC §2.1051 & §90.1323(a) - SPURIOUS EMISSIONS AT ANTENNA TERMINALS

Applicable Standard

FCC §2.1051 and §90.1323(a)

Limit

According to FCC §90.1323(a), The power of any emission outside a licensee's frequency band(s) of operation shall be attenuated below the transmitter power (P) within the licensed band(s) of operation, measured in watts, by at least $43 + 10 \log (P)$ dB. Compliance with this provision is based on the use of measurement instrumentation employing a resolution bandwidth of 1 MHz or less, but at least one percent of the emission bandwidth of the fundamental emission of the transmitter, provided the measured energy is integrated over a 1 MHz bandwidth.

Test Procedure

The EUT was connected to a CMW500 & signal analyzer through a splitter, the EUT power was adjusted to produce maximum output power as specified in the owner's manual, measurements were performed at low, middle high channels for each of the EUT's bandwidths and modulations.

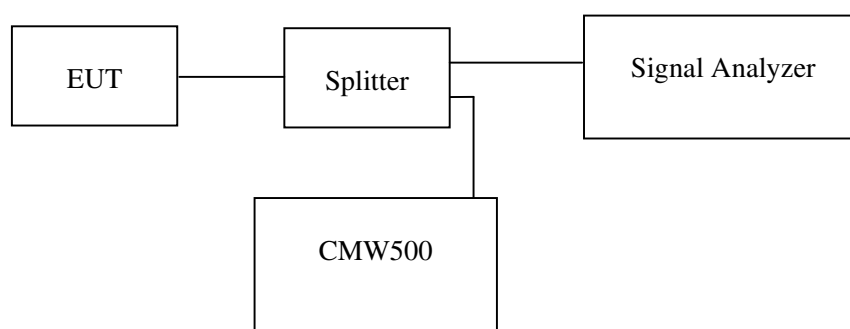

Test Equipment List and Details

Manufacturer	Description	Model No.	Serial No.	Calibration Date	Calibration Due Date
Rohde & Schwarz	Signal Analyzer	FSIQ26	8386001028	2015-11-12	2016-11-12
Agilent	Spectrum analyzer	8564E	3943A01781	2015-06-14	2016-06-13
R & S	Wideband Radio Communication Tester	CMW500	114772	2015-11-15	2016-11-14
Ducommun technologies	RF Cable	RG-214	3	2015-06-15	2016-06-15
WEINSCHEL	3dB Attenuator	5321	AU0709	2015-06-18	2016-06-18

* **Statement of Traceability:** Bay Area Compliance Laboratories Corp. (Shenzhen) attests that all calibrations have been performed in accordance to requirements, traceable to National Primary Standards and International System of Units (SI).

Test Data

Environmental Conditions

Temperature:	23-26 °C
Relative Humidity:	52-56 %
ATM Pressure:	100.3-101.0 kPa

The testing was performed by Joson Xiao from 2016-04-22 to 2016-06-06.

Test Mode: Transmitting

QPSK(5M)(Channel 30 MHz – 1 GHz)

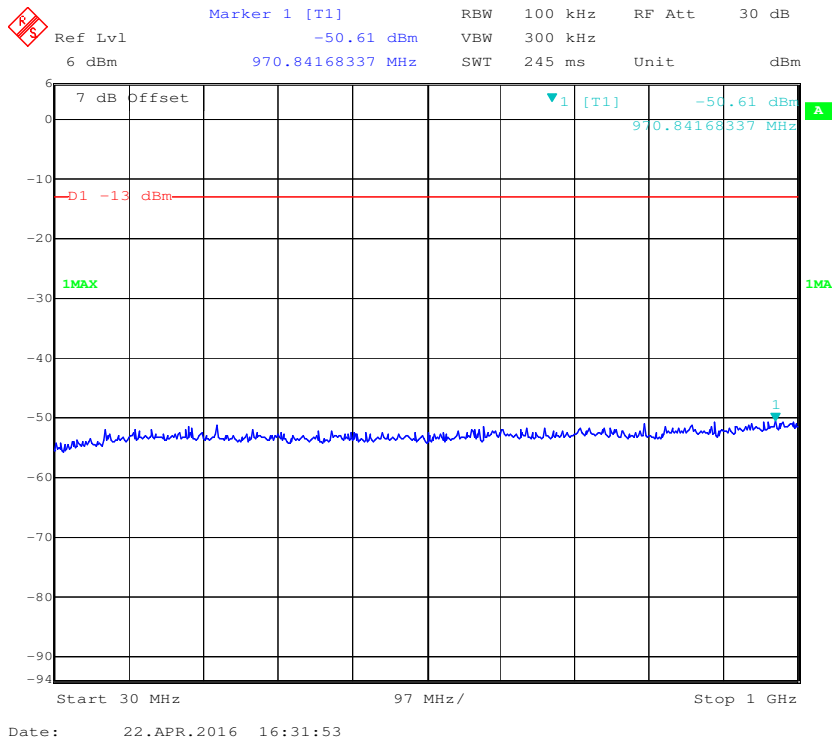

16QAM(5M)(Channel 30 MHz – 1 GHz)

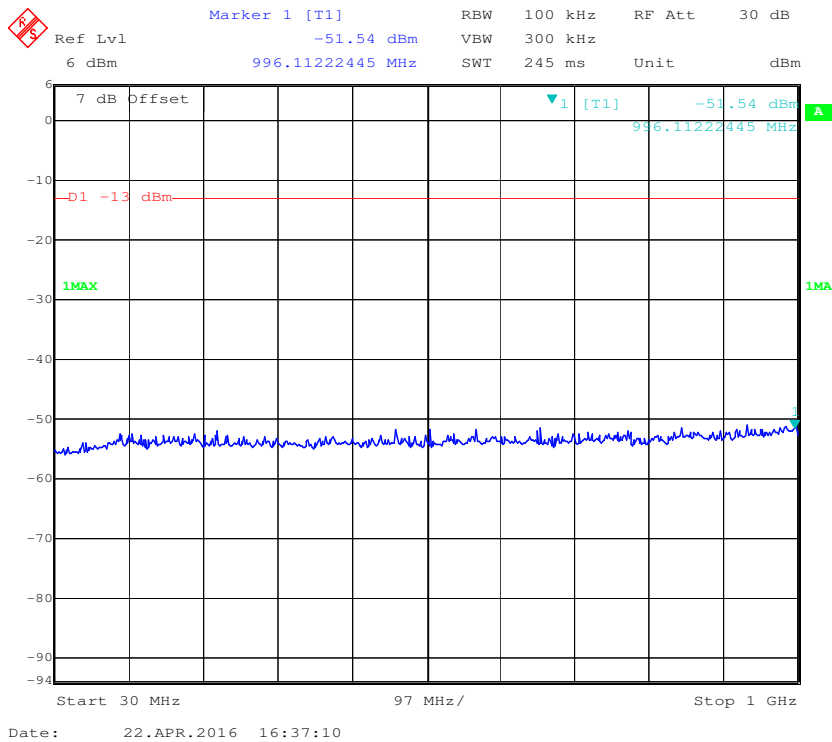

QPSK(5M)(Channel 1 GHz-26.5 GHz)

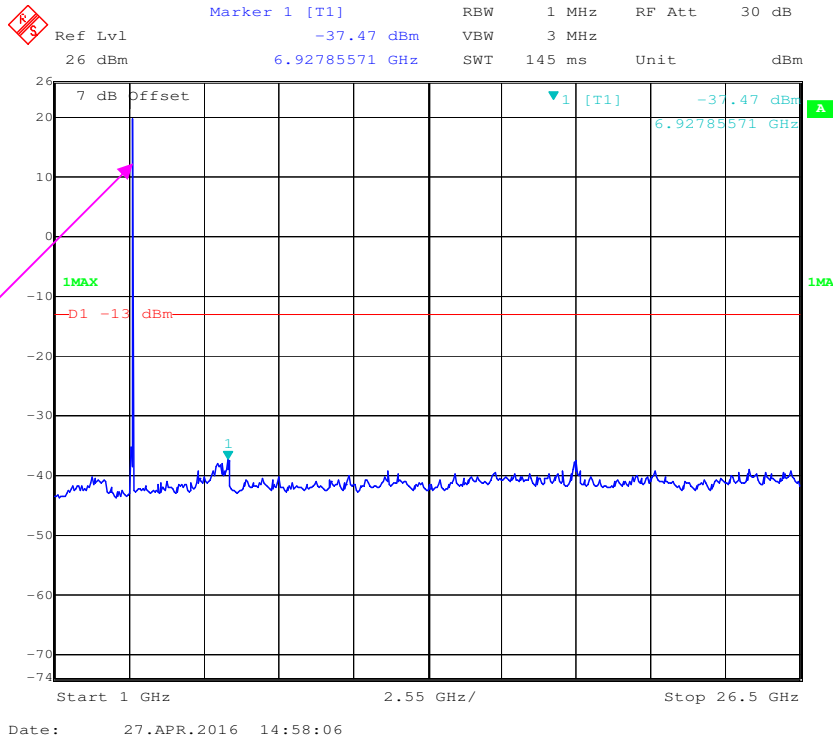

Fund.test

16QAM(5M)(Channel 1 GHz-26.5 GHz)

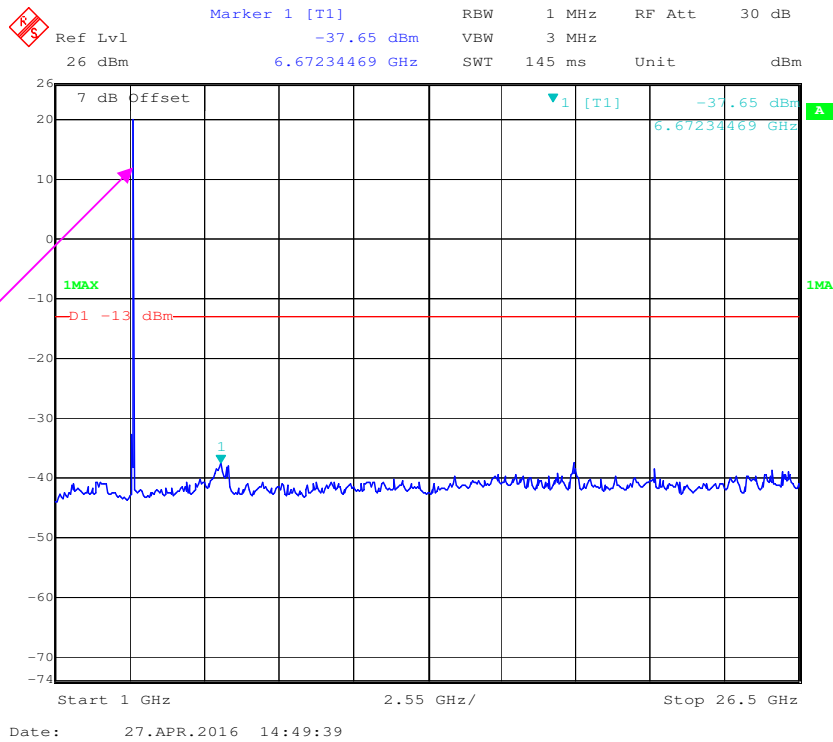

Fund.test

QPSK(5M)(Channel 26.5 GHz-40 GHz)

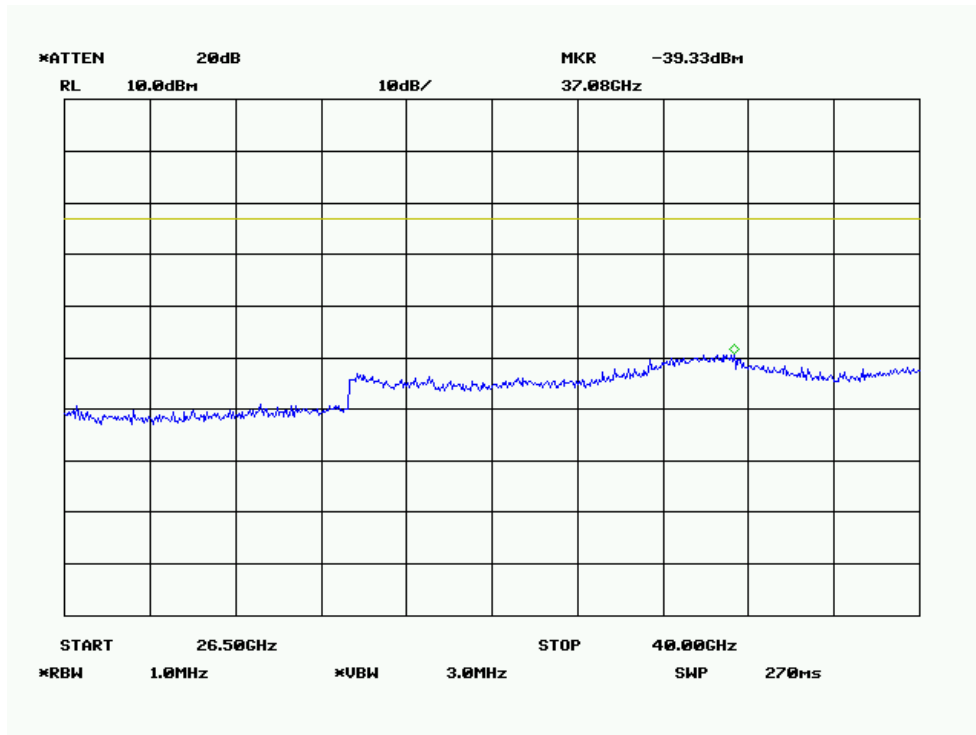

16QAM(5M)(Channel 26.5 GHz-40 GHz)

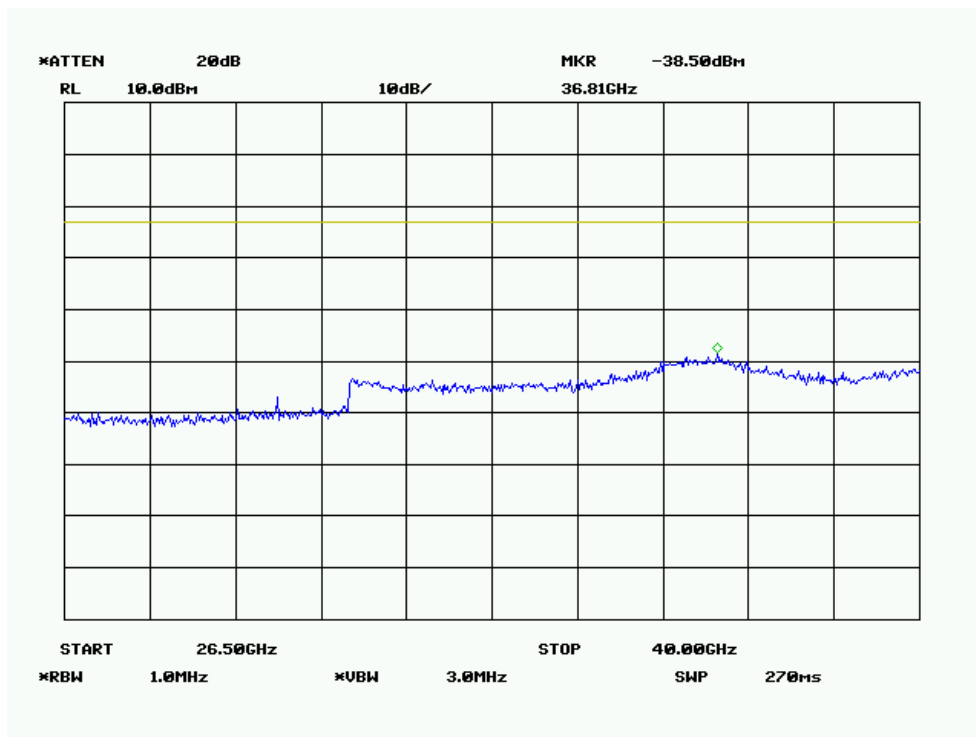

QPSK(10M)(Channel 1 GHz-26.5 GHz)

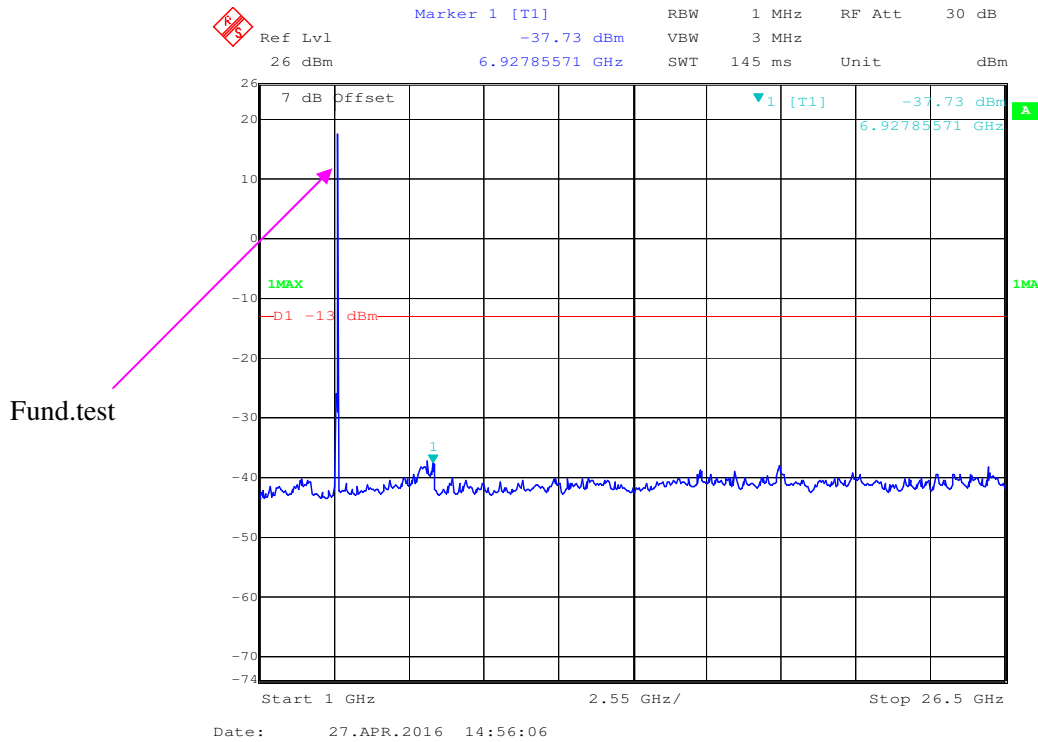

16QAM(10M)(Channel 1 GHz-26.5 GHz)

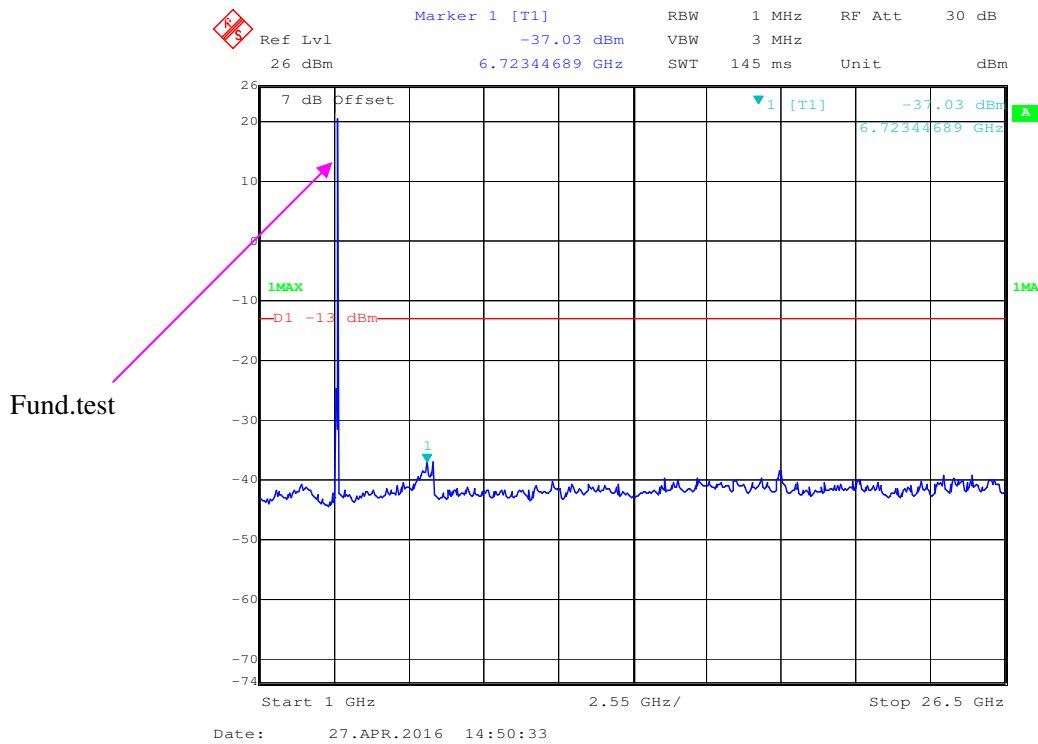

QPSK(10M)(Channel 26.5 GHz-40 GHz)

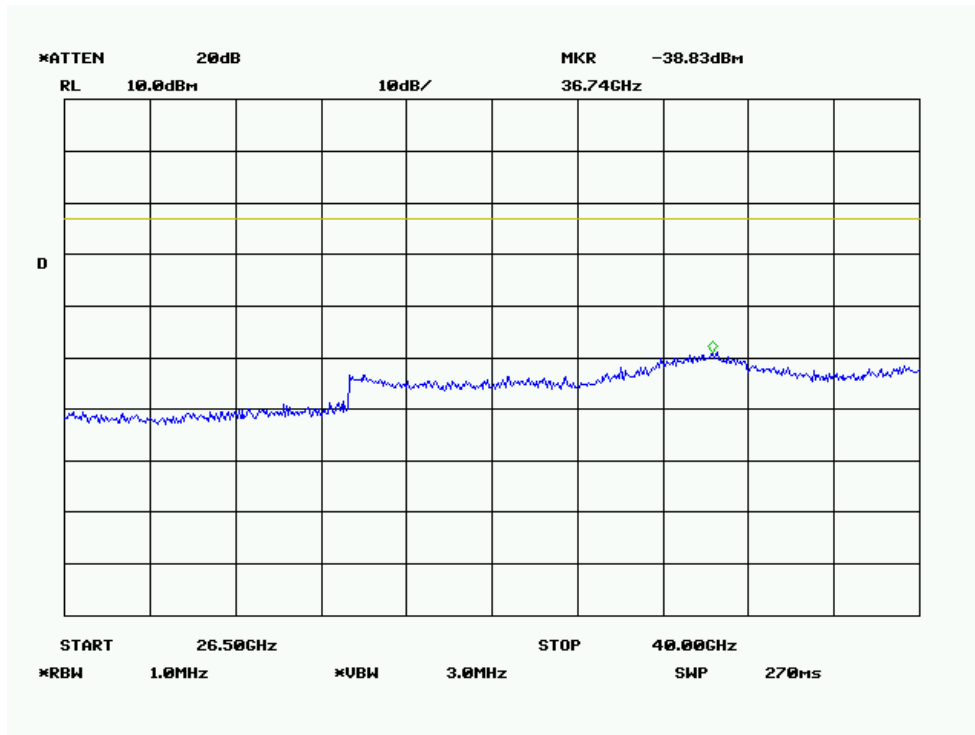

16QAM(10M)(Channel 26.5 GHz-40 GHz)

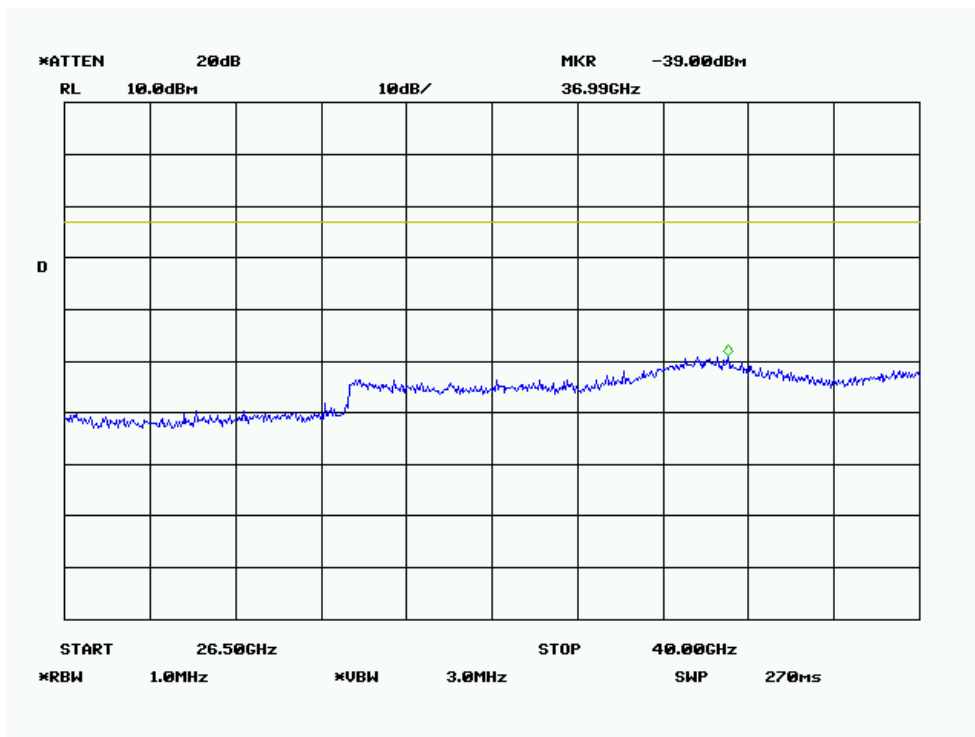

QPSK(15M)(Channel 1 GHz-26.5 GHz)

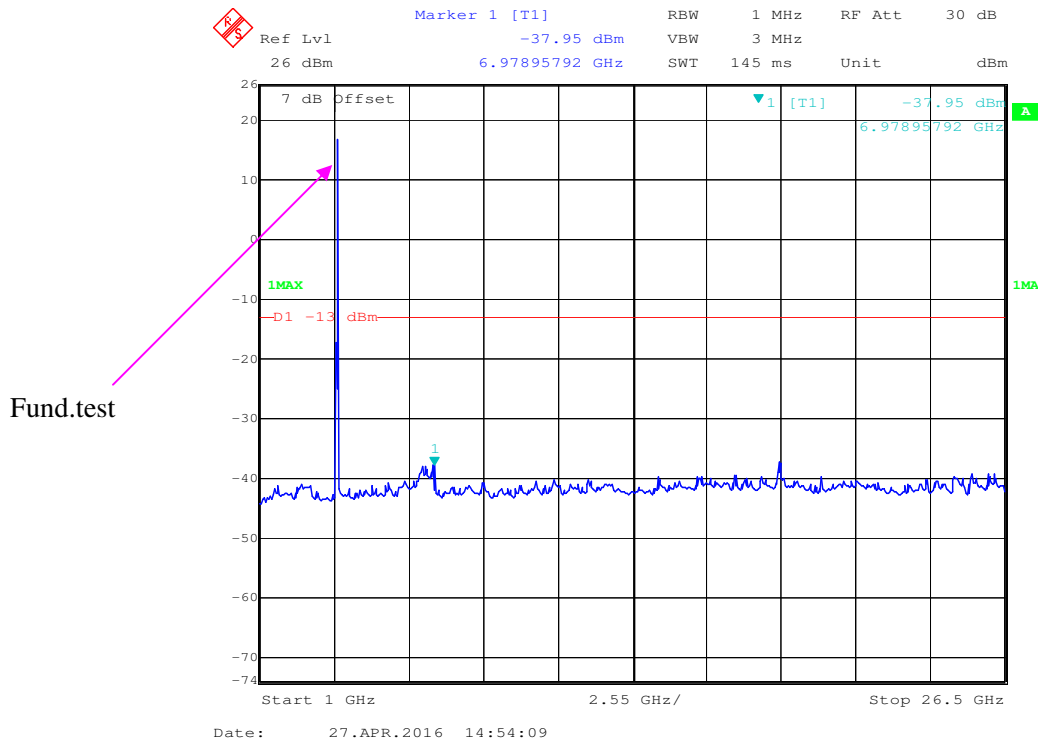

16QAM(15M)(Channel 1 GHz-26.5 GHz)

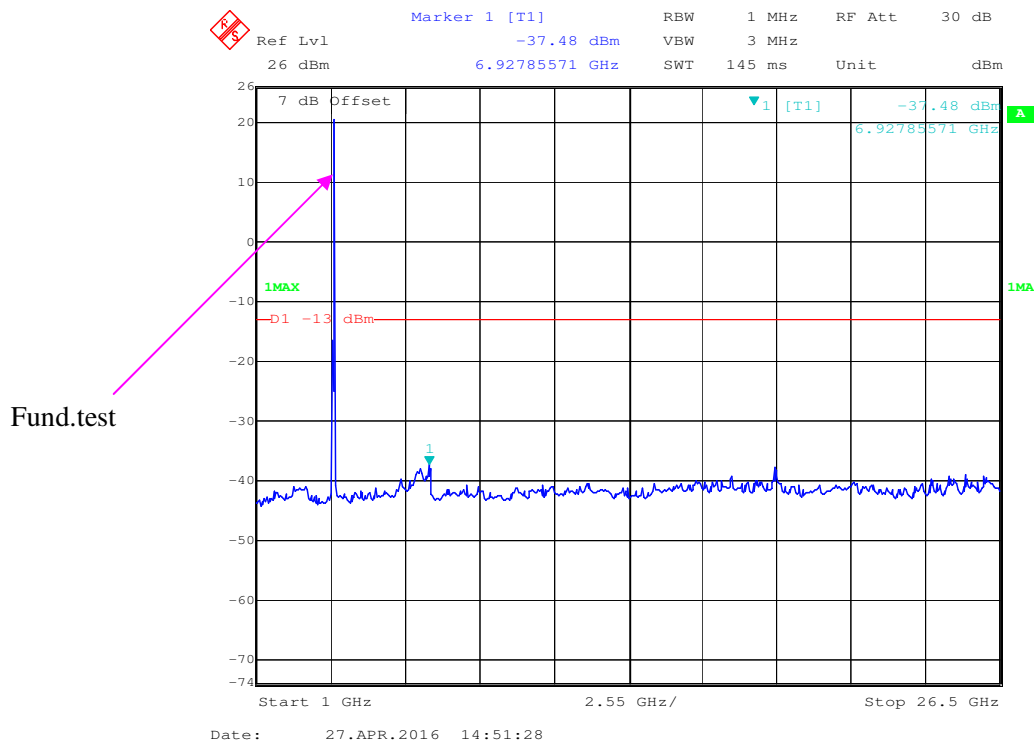

QPSK(15M)(Channel 26.5 GHz-40 GHz)

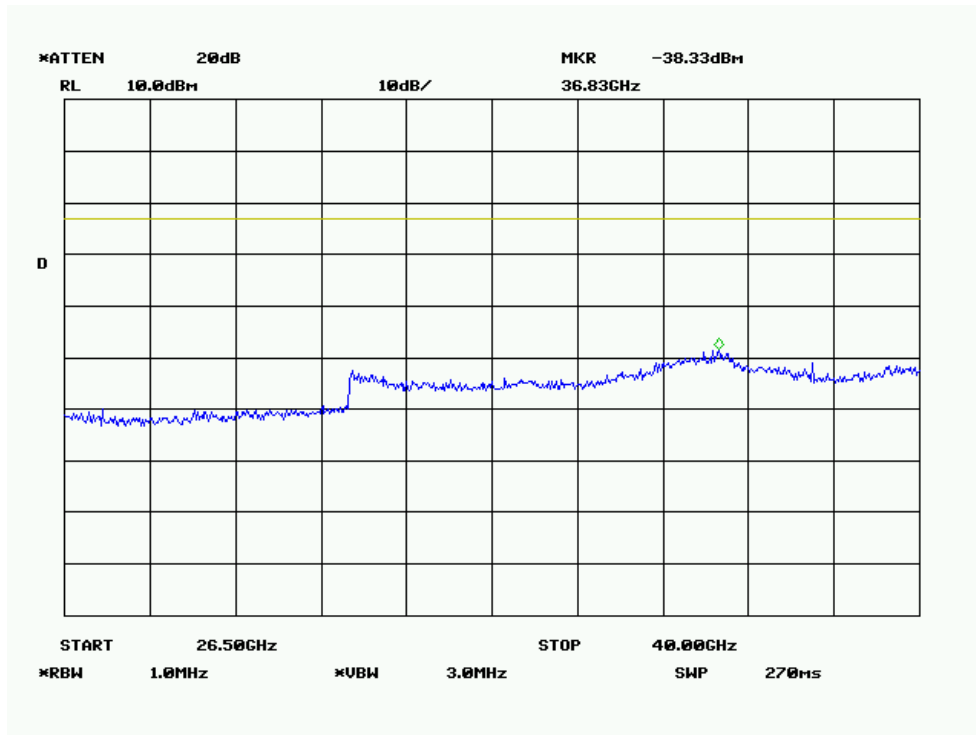

16QAM(15M)(Channel 26.5 GHz-40 GHz)

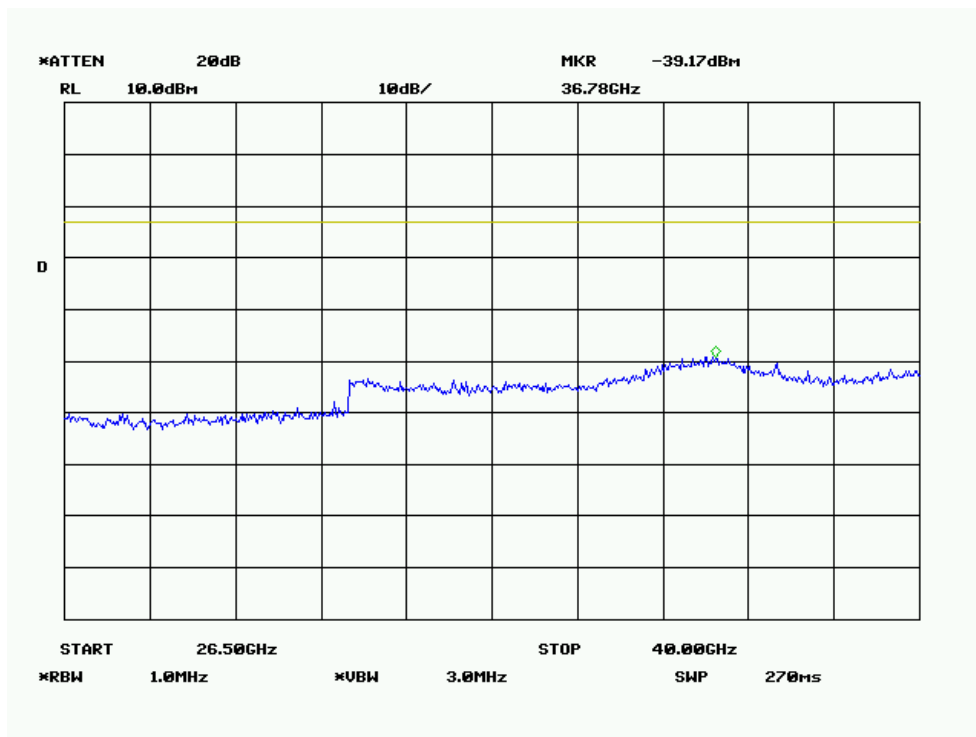

QPSK(20M)(Channel 30 MHz – 1 GHz)

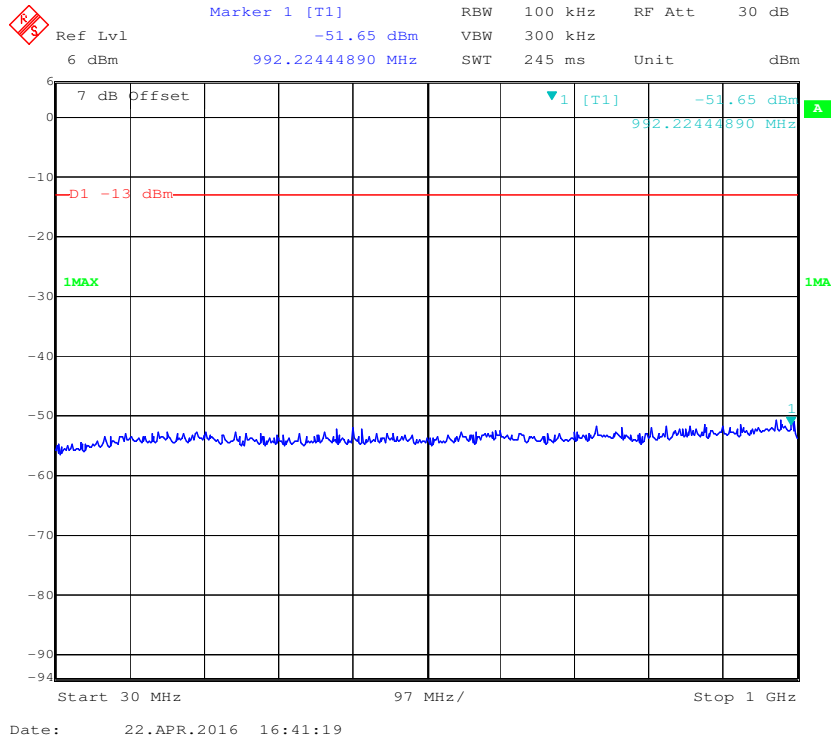

16QAM(20M)(Channel 30 MHz – 1 GHz)

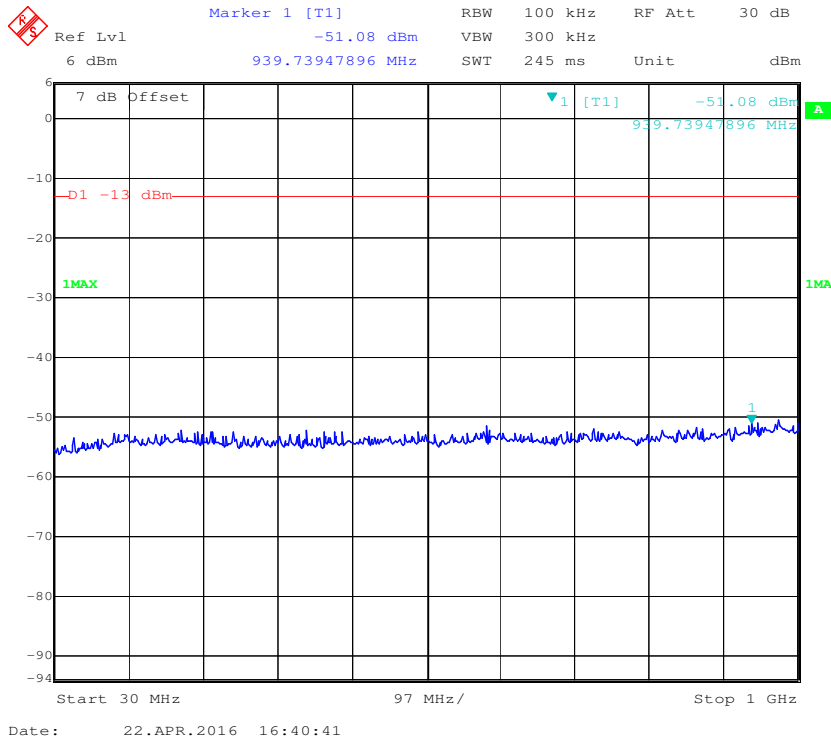

QPSK(20M)(Channel 1 GHz-26.5 GHz)

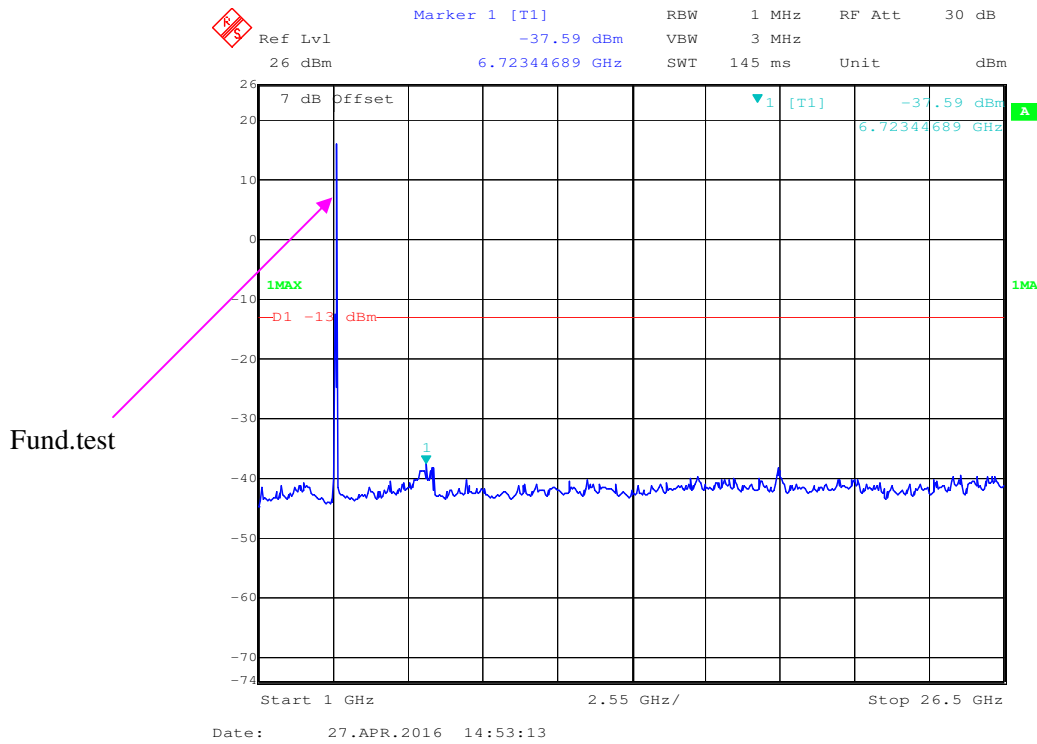

16QAM(20M)(Channel 1 GHz-26.5 GHz)

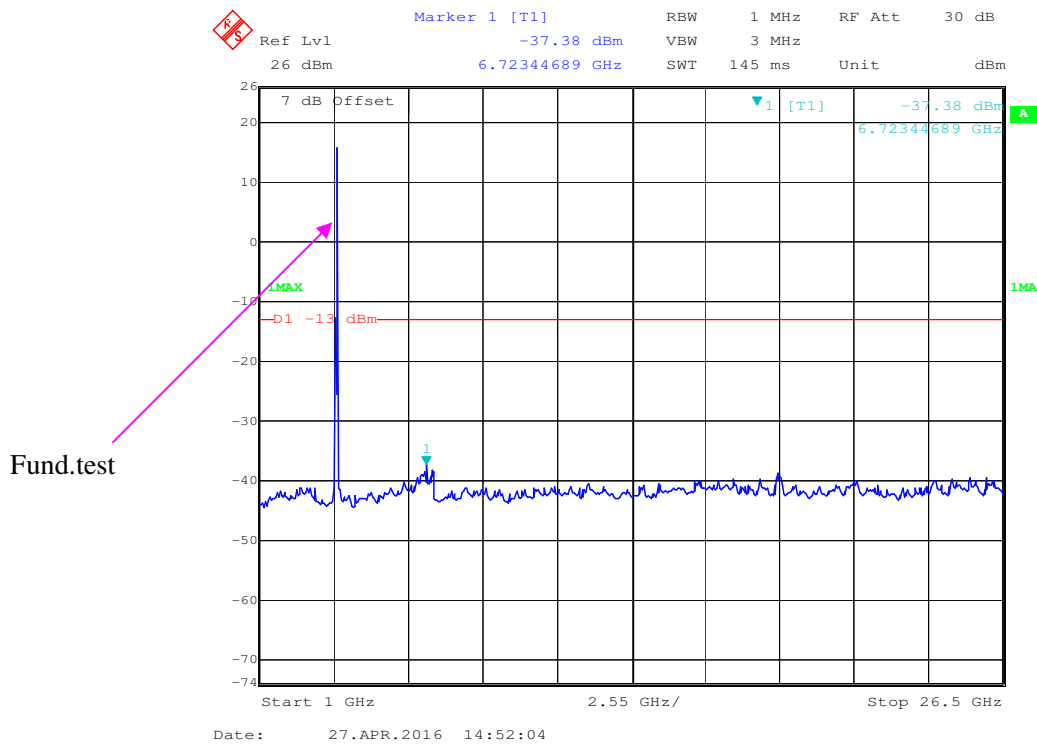

QPSK(20M)(Channel 26.5 GHz-40 GHz)

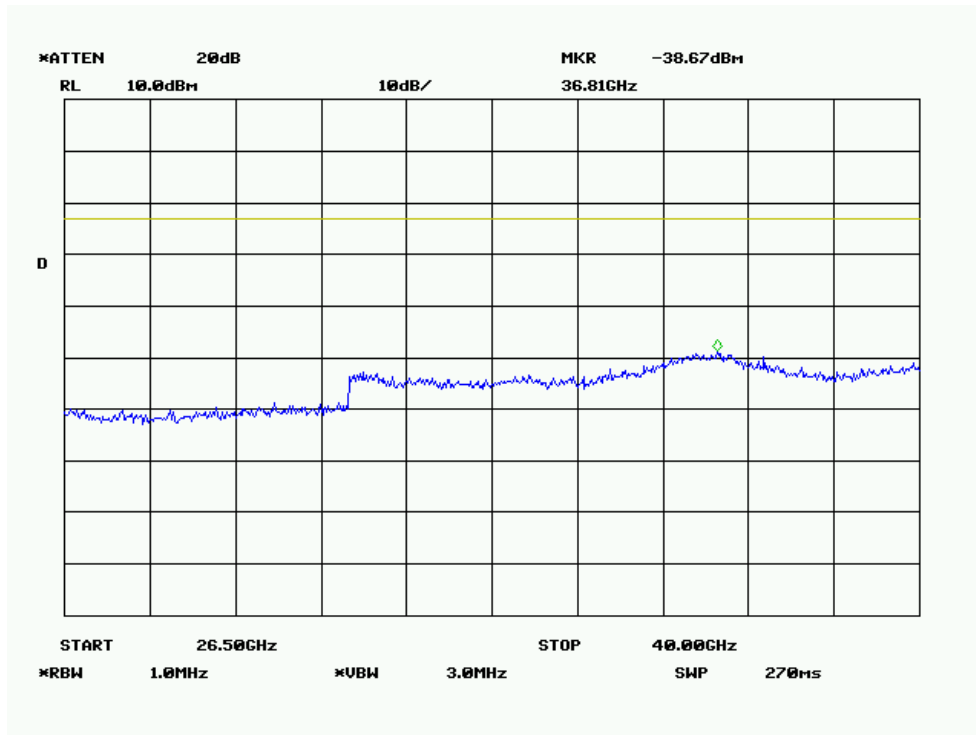

16QAM(20M)(Channel 26.5 GHz-40 GHz)

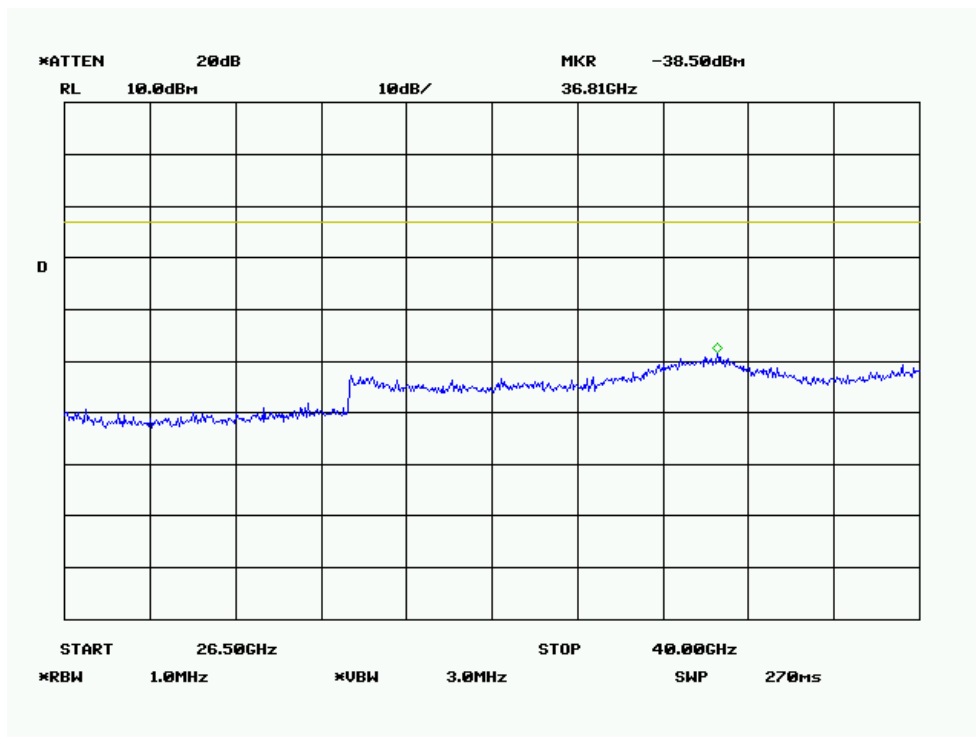

Bandage:

QPSK (5MHz), Left Side

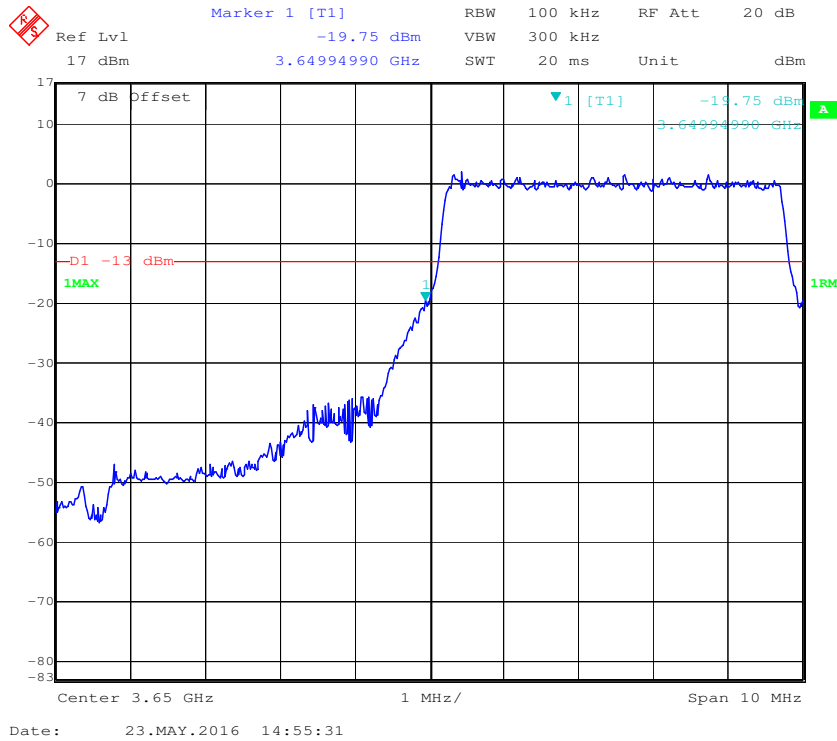

QPSK (5MHz), Right Side

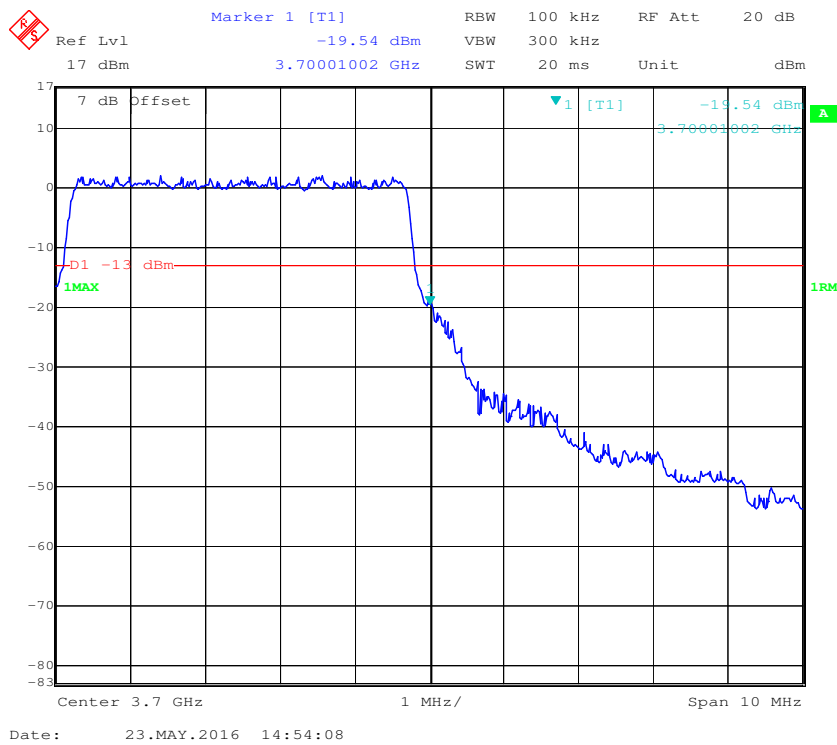

16QAM (5MHz), Left Side

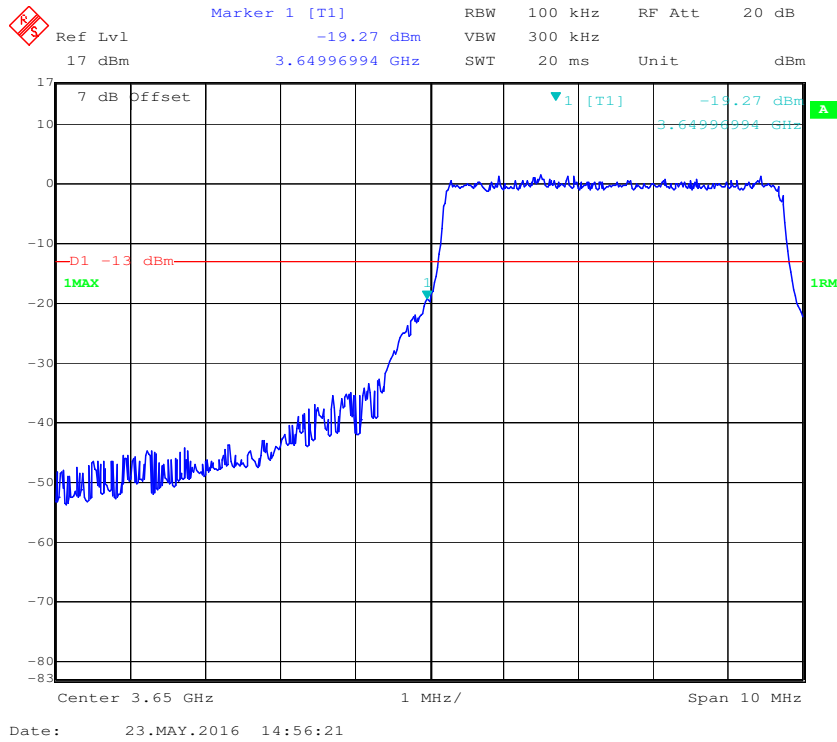

16QAM (5MHz), Right Side

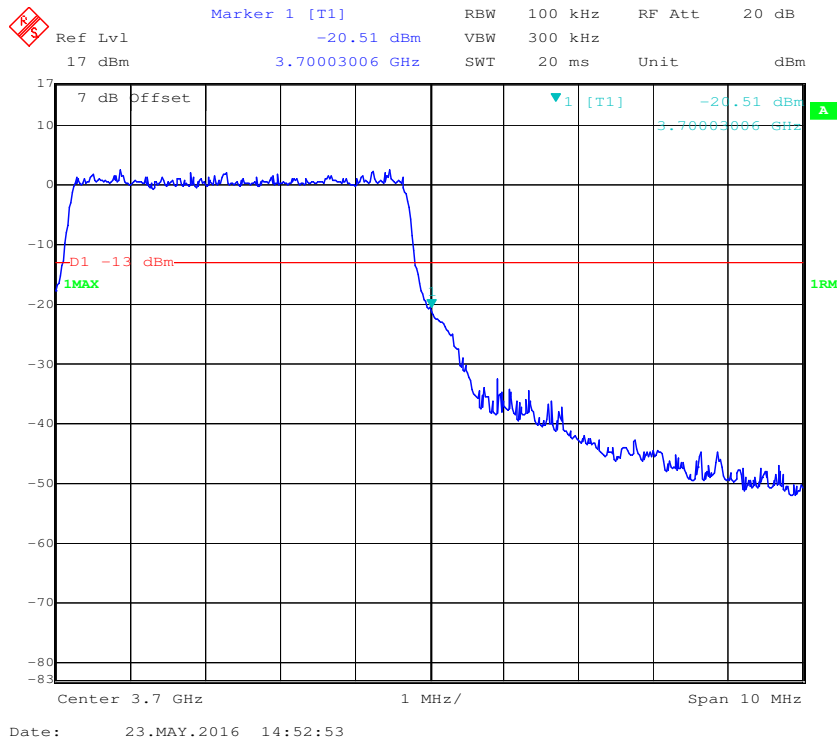

QPSK (10MHz), Left Side

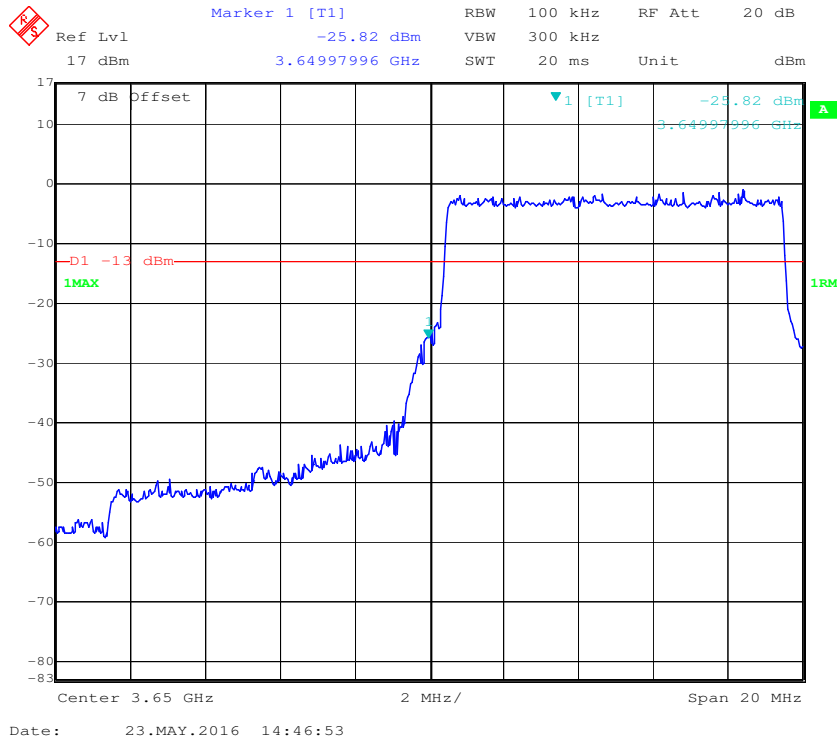

QPSK (10MHz), Right Side

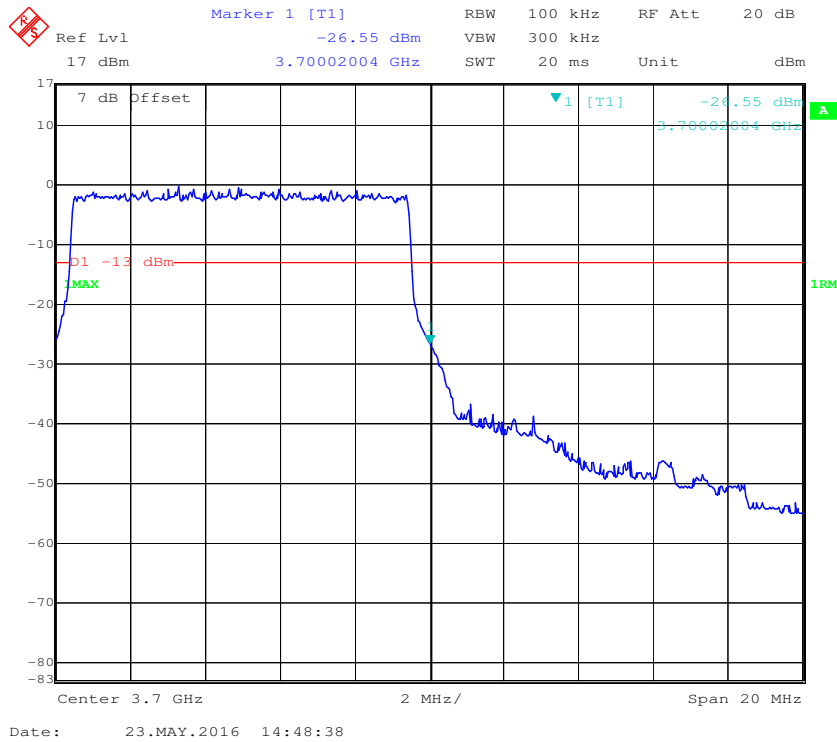

16QAM (10MHz), Left Side

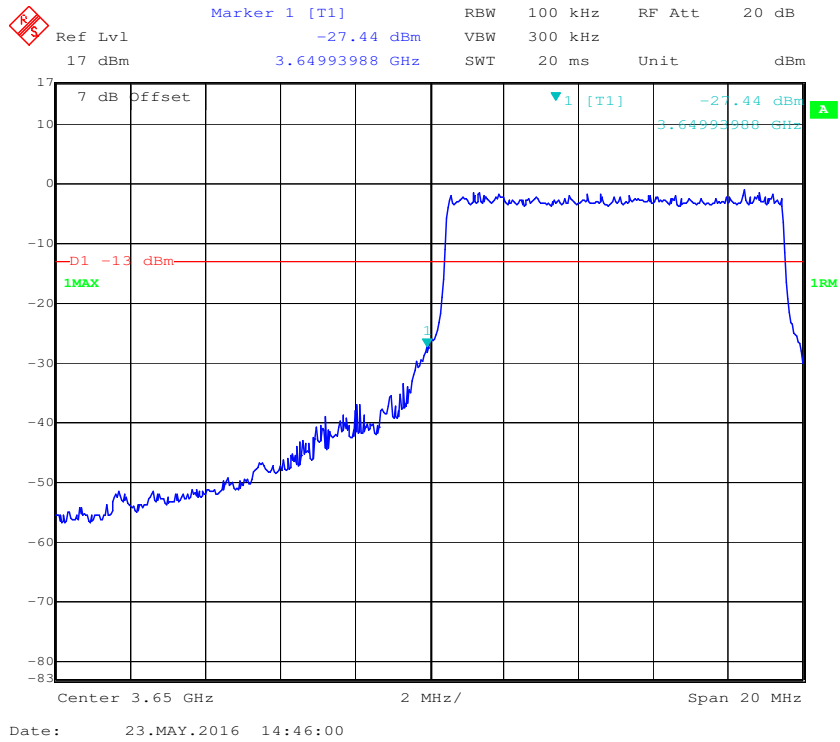

16QAM (10MHz), Right Side

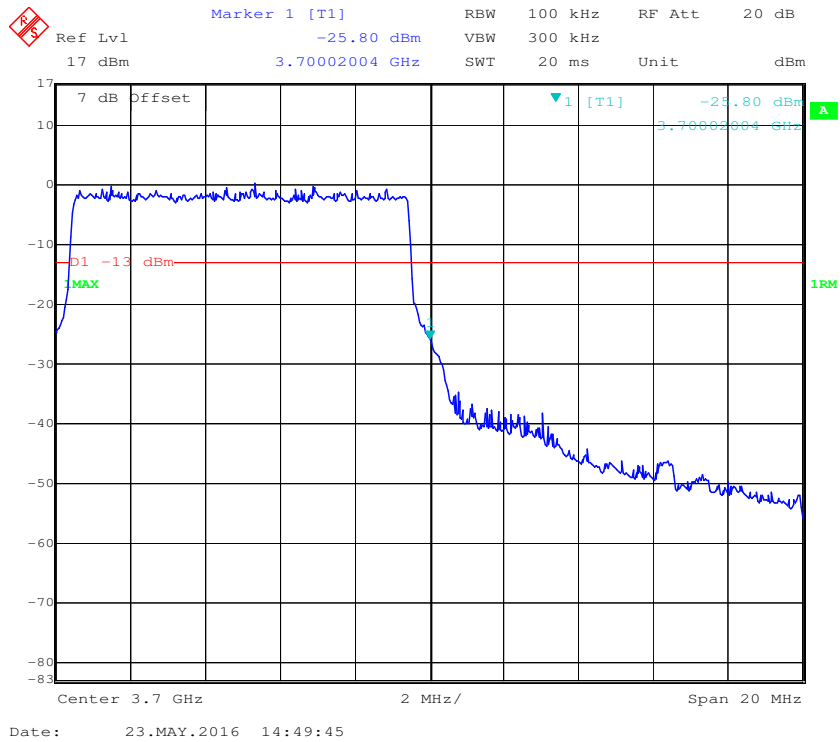

QPSK (15MHz), Left Side

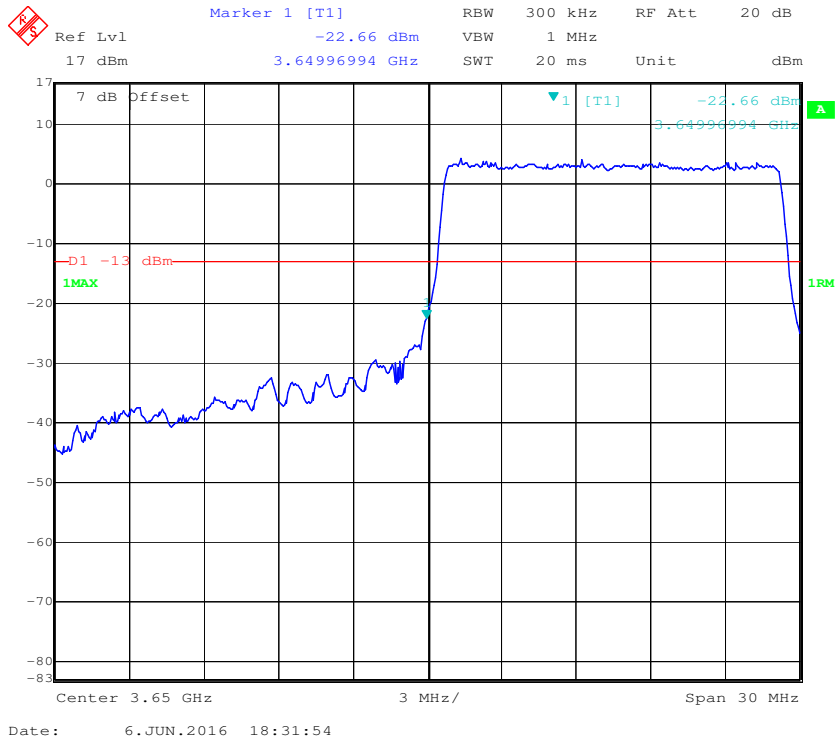

QPSK (15MHz), Right Side

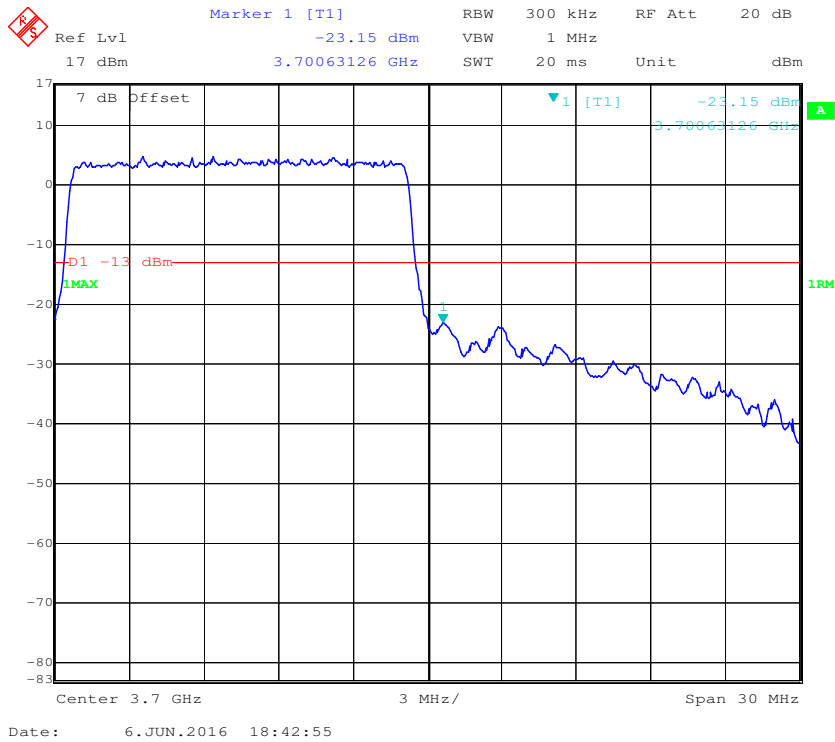

16QAM (15MHz), Left Side

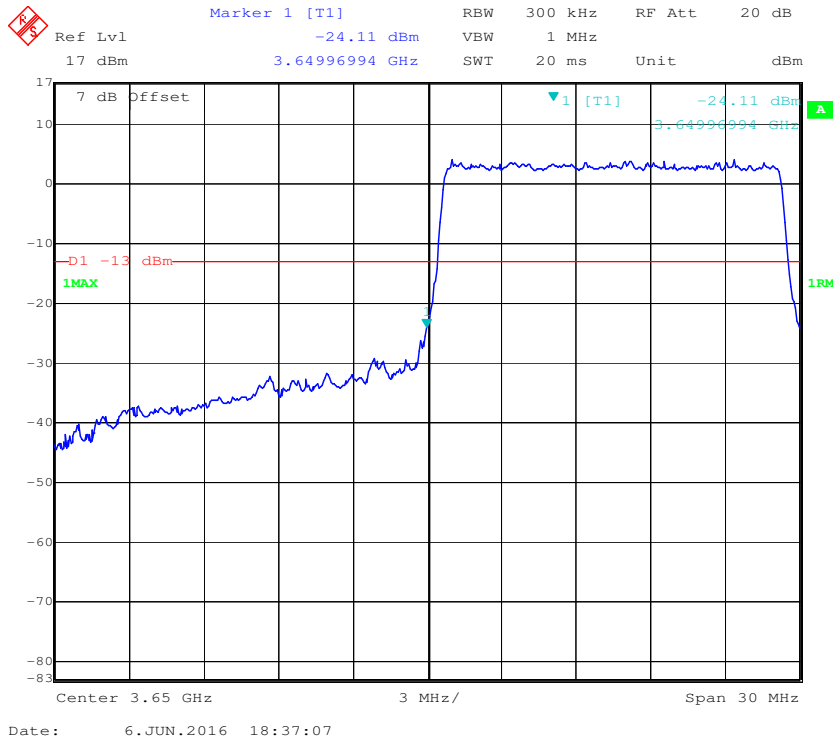

16QAM (15MHz), Right Side

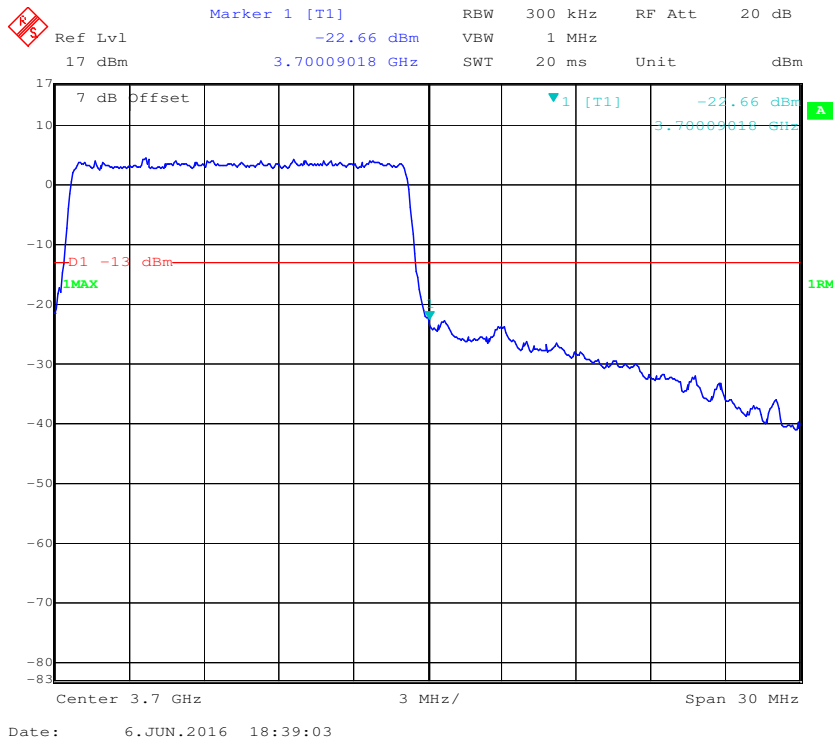

QPSK (20MHz), Left Side

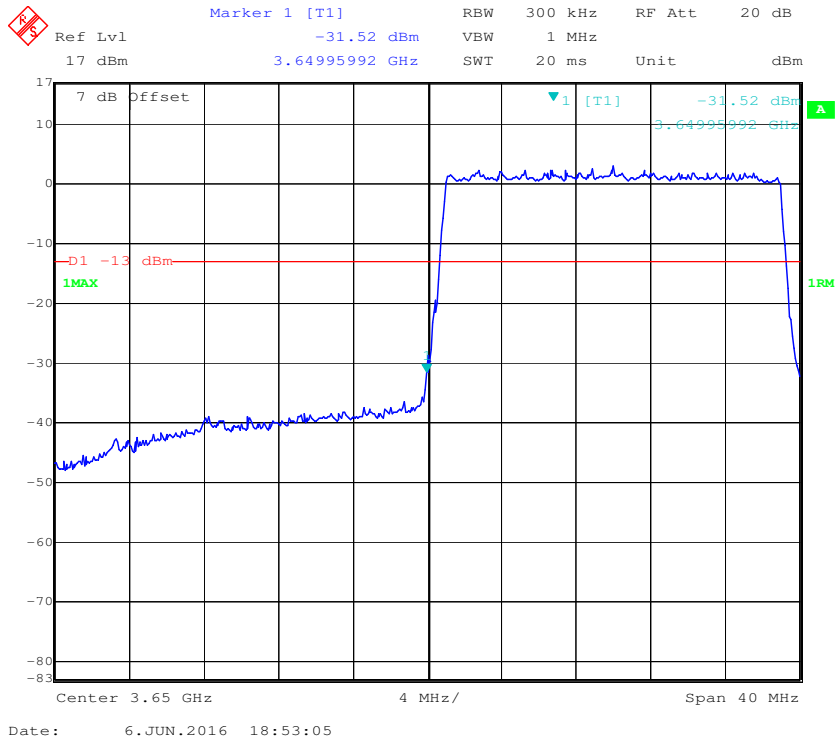

QPSK (20MHz), Right Side

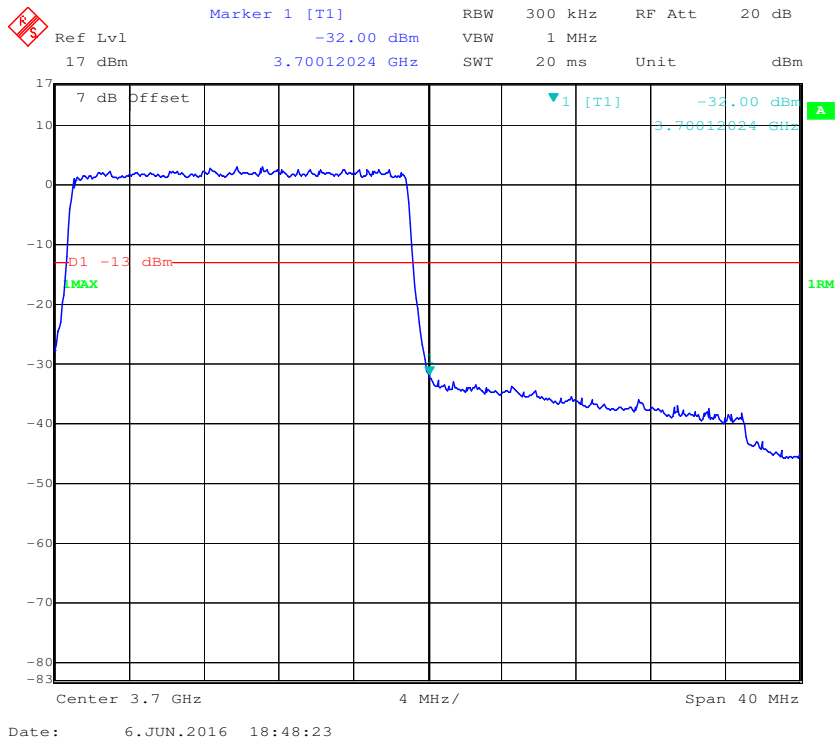

16QAM (20MHz), Left Side

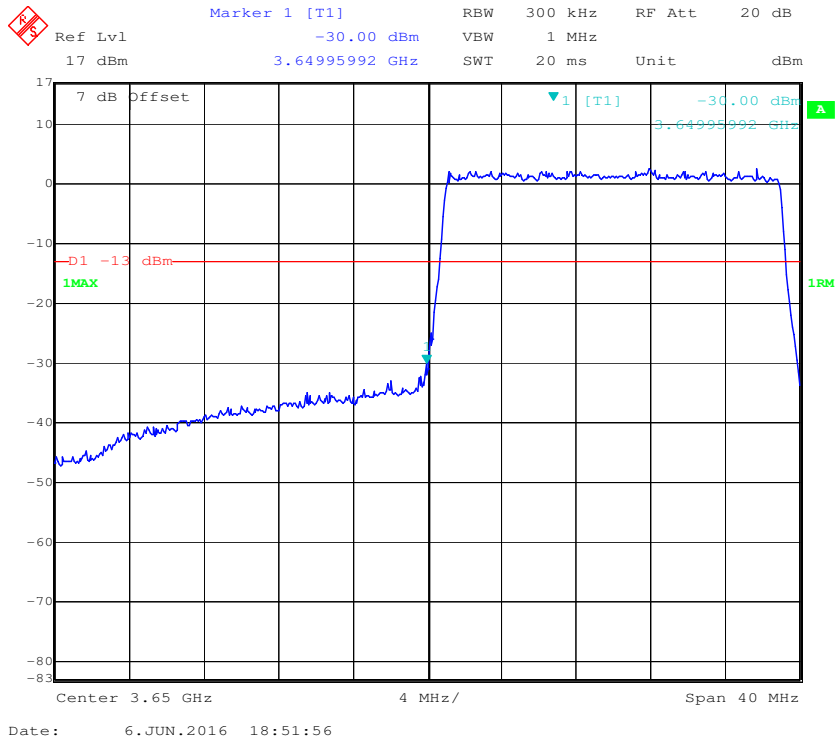

16QAM (20MHz), Right Side

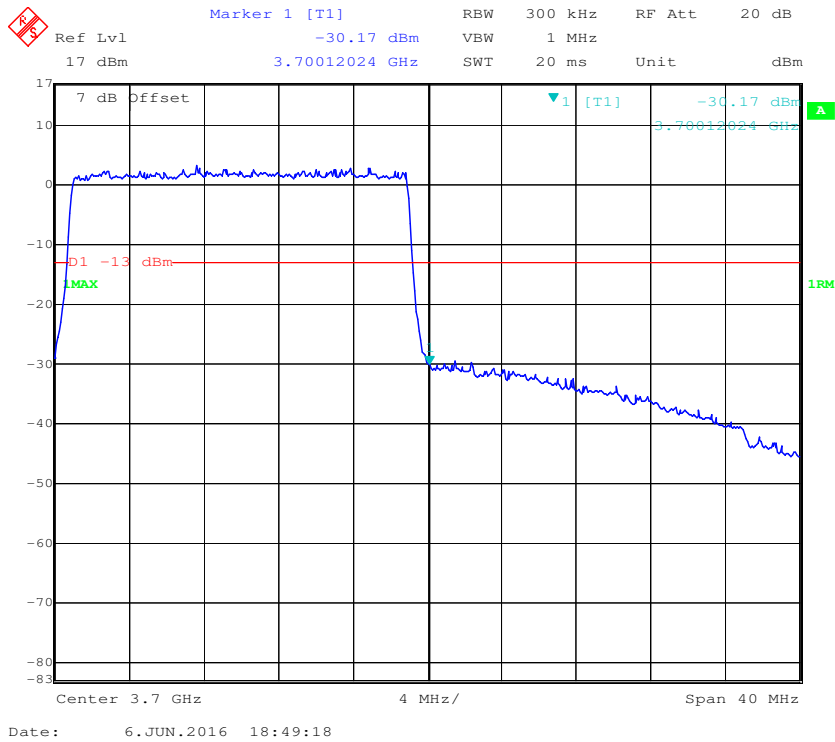

FCC §2.1053 - RADIATED SPURIOUS EMISSIONS

Applicable Standard

FCC §2.1053

Test Procedure

The transmitter was placed on a wooden turntable, and it was transmitting into a non-radiating load, which was also placed on the turntable.

The measurement antenna was placed at a distance of 3 meters from the EUT. During the tests, the antenna height and polarization as well as EUT azimuth were varied in order to identify the maximum level of emissions from the EUT. The test was performed by placing the EUT on 3-orthogonal axis.

The frequency range up to teeth harmonic of the fundamental frequency was investigated.

Remove the EUT and replace it with substitution antenna. A signal generator was connected to the substitution antenna by a non-radiating cable. The absolute levels of the spurious emissions were measured by the substitution.

Spurious attenuation limit in dB = $43 + 10 \log_{10}$ (power out in Watts)

Test Equipment List and Details

Manufacturer	Description	Model No.	Serial No.	Calibration Date	Calibration Due Date
Sunol Sciences	Horn Antenna	DRH-118	A052304	2015-12-01	2016-11-30
Sunol Sciences	Broadband Antenna	JB1	A040904-2	2014-11-28	2017-11-27
Rohde & Schwarz	Signal Analyzer	FSIQ26	8386001028	2015-11-12	2016-11-12
Rohde & Schwarz	EMI Test Receiver	ESCI	101122	2015-09-25	2016-09-25
HP	Amplifier	8447E	1937A01046	2015-09-30	2016-09-30
Mini	Amplifier	ZVA-183-S+	5969001149	2016-04-03	2017-04-03
HP	Signal Generator	8657A	3217A04699	2015-12-19	2016-12-18
A.H. System	Horn Antenna	SAS-200/571	135	2015-08-18	2018-08-17
HP	Synthesized Sweeper	8341B	2624A00116	2015-05-09	2016-05-09
R & S	Wideband Radio Communication Tester	CMW500	114772	2015-11-15	2016-11-14
COM POWER	Dipole Antenna	AD-100	041000	NCR	NCR
Ducommun technologies	RF Cable	UFA210A-1-4724-30050U	MFR64369 223410-001	2015-06-15	2016-06-15
Ducommun technologies	RF Cable	104PEA	218124002	2015-06-15	2016-06-15
Ducommun technologies	RF Cable	RG-214	1	2015-06-15	2016-06-15
Ducommun technologies	RF Cable	RG-214	2	2015-06-15	2016-06-15

* **Statement of Traceability:** Bay Area Compliance Laboratories Corp. (Shenzhen) attests that all calibrations have been performed in accordance to requirements, traceable to National Primary Standards and International System of Units (SI).

Test Data

Environmental Conditions

Temperature:	27 °C
Relative Humidity:	56 %
ATM Pressure:	101.0 kPa

The testing was performed by Joson Xiao on 2016-04-26.

Test Mode: Transmitting

30MHz - 40GHz (The worst case is QPSK):

Frequency (MHz)	Receiver Reading (dBµV)	Turn Table Angle Degree	Rx Antenna		Substituted			Absolute Level (dBm)	FCC Part 90	
			Height (m)	Polar (H/V)	SG Level (dBm)	Cable Loss (dB)	Antenna Gain (dB)		Limit (dBm)	Margin (dB)
QPSK(5MHz), Middle channel (3675MHz)										
151.82	42.63	220	1.9	H	-54.4	0.27	0	-54.67	-13	41.67
151.82	41.36	39	1.4	V	-55.6	0.27	0	-55.87	-13	42.87
7350.00	44.75	76	1.5	H	-46.5	2.70	10.70	-38.50	-13	25.50
7350.00	42.43	255	1.5	V	-49.4	2.70	10.70	-41.40	-13	28.40
QPSK(10MHz), Middle channel (3675MHz)										
151.82	43.57	179	2.2	H	-53.4	0.27	0	-53.67	-13	40.67
151.82	41.28	229	1.6	V	-55.7	0.27	0	-55.97	-13	42.97
7350.00	46.37	115	1.5	H	-47.1	2.70	10.70	-39.10	-13	26.10
7350.00	44.52	324	1.3	V	-49.5	2.70	10.70	-41.50	-13	28.50
QPSK(15MHz), Middle channel (3675MHz)										
151.82	44.27	43	1.7	H	-52.7	0.27	0	-52.97	-13	39.97
151.82	42.09	160	2.1	V	-54.9	0.27	0	-55.17	-13	42.17
7350.00	45.77	104	2.0	H	-47.7	2.70	10.70	-39.70	-13	26.70
7350.00	43.85	117	2.2	V	-50.1	2.70	10.70	-42.10	-13	29.10
QPSK(20MHz), Middle channel (3675MHz)										
151.82	43.57	246	2.0	H	-53.4	0.27	0	-53.67	-13	40.67
151.82	41.33	25	2.4	V	-55.7	0.27	0	-55.97	-13	42.97
7350.00	47.79	321	1.9	H	-45.7	2.70	10.70	-37.70	-13	24.70
7350.00	45.36	105	2.3	V	-48.6	2.70	10.70	-40.60	-13	27.60

Note:

Absolute Level = SG Level - Cable loss + Antenna Gain

Margin = Limit- Absolute Level

FCC §2.1055 & §90.213- FREQUENCY STABILITY

Applicable Standard

FCC §2.1055, §90.213

Test Procedure

Frequency Stability vs. Temperature: The equipment under test was connected to an external AC power supply and the RF output was connected to a frequency counter via feed-through attenuators. The EUT was placed inside the temperature chamber. The AC leads and RF output cable exited the chamber through an opening made for the purpose.

After the temperature stabilized for approximately 20 minutes, the frequency output was recorded from the counter.

Test Equipment List and Details

Manufacturer	Description	Model No.	Serial No.	Calibration Date	Calibration Due Date
Rohde & Schwarz	Wideband Radio Communication Tester	CMW500	114772	2015-11-15	2016-11-14
ESPEC	Temperature & Humidity Chamber	EL-10KA	09107726	2015-11-01	2016-11-01
Ducommun technologies	RF Cable	RG-214	3	2015-06-15	2016-06-15
WEINSCHEL	3dB Attenuator	5321	AU0709	2015-06-18	2016-06-18

* **Statement of Traceability:** Bay Area Compliance Laboratories Corp. (Shenzhen) attests that all calibrations have been performed in accordance to requirements, traceable to National Primary Standards and International System of Units (SI).

Test Data

Environmental Conditions

Temperature:	27 °C
Relative Humidity:	56 %
ATM Pressure:	101.0 kPa

The testing was performed by Joson Xiao on 2016-05-08.

Test Mode: Transmitting

LTE band (3650-3700MHz) Middle Channel

Test Environment		Reference frequency (MHz)	Frequency Error (Hz)	Frequency Error (ppm)	Result
Power Supplied (V _{AC})	Temperature (°C)				
Frequency Stability versus Input Temperature					
120	50	3675	8	0.00218	Compliant
	45	3675	10	0.00272	Compliant
	35	3675	9	0.00245	Compliant
	25	3675	10	0.00272	Compliant
	15	3675	11	0.00299	Compliant
	5	3675	12	0.00327	Compliant
	-5	3675	6	0.00163	Compliant
	-15	3675	7	0.00190	Compliant
	-25	3675	9	0.00245	Compliant
	-30	3675	10	0.00272	Compliant
Frequency Stability versus Input Voltage					
108	25	3675	4	0.00109	Compliant
132	25	3675	7	0.00190	Compliant

******* END OF REPORT *******