



BUREAU VERITAS

Test Report No.: W7L-240507W001RF03



FCC TEST REPORT

(Part 15, Subpart E)



Applicant:	Xiaomi Communications Co., Ltd.
Address:	#019, 9th Floor, Building 6, 33 Xi'erqi Middle Road, Haidian District, Beijing, China, 100085

Manufacturer or Supplier:	Xiaomi Communications Co., Ltd.
Address:	#019, 9th Floor, Building 6, 33 Xi'erqi Middle Road, Haidian District, Beijing, China, 100085
Product:	Tablet Computer
Brand Name:	Redmi
Model Name:	24075RP89G
FCC ID:	2AFZZRP89G
Date of tests:	May. 07, 2024 ~ May. 24, 2024

The tests have been carried out according to the requirements of the following standard:

FCC Part 15, Subpart E, Section 15.407

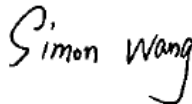
CONCLUSION: The submitted sample was found to COMPLY with the test requirement

Prepared by Simon Wang Engineer / Mobile Department	Approved by Luke Lu Manager / Mobile Department
 Date: May. 24, 2024	 Date: May. 24, 2024

This report is governed by, and incorporates by reference, the Conditions of Testing as posted at the date of issuance of this report at <http://www.bureauveritas.com/home/about-us/our-business/cps/about-us/terms-conditions/> and is intended for your exclusive use. Any copying or replication of this report to or for any other person or entity, or use of our name or trademark, is permitted only with our prior written permission. This report sets forth our findings solely with respect to the test samples identified herein. The results set forth in this report are not indicative or representative of the quality or characteristics of the lot from which a test sample was taken or any similar or identical product unless specifically and expressly noted. Our report includes all of the tests requested by you and the results thereof based upon the information that you provided to us. Measurement uncertainty is only provided upon request for accredited tests. Statements of conformity are based on simple acceptance criteria without taking measurement uncertainty into account, unless otherwise requested in writing. You have 60 days from date of issuance of this report to notify us of any material error or omission caused by our negligence or if you require measurement uncertainty; provided, however, that such notice shall be in writing and shall specifically address the issue you wish to raise. A failure to raise such issue within the prescribed time shall constitute your unqualified acceptance of the completeness of this report, the tests conducted and the correctness of the report contents.



TABLE OF CONTENTS

RELEASE CONTROL RECORD	4
1 SUMMARY OF TEST RESULTS	5
1.1 MEASUREMENT UNCERTAINTY	6
2 GENERAL INFORMATION.....	7
2.1 GENERAL DESCRIPTION OF EUT	7
2.2 DESCRIPTION OF TEST MODES.....	9
2.2.1 TEST MODE APPLICABILITY AND TESTED CHANNEL DETAIL.....	12
2.3 DUTY CYCLE OF TEST SIGNAL.....	17
2.4 DESCRIPTION OF SUPPORT UNITS	18
2.4.1 CONFIGURATION OF SYSTEM UNDER TEST	19
2.5 GENERAL DESCRIPTION OF APPLIED STANDARDS	20
3 TEST TYPES AND RESULTS.....	21
3.1 RADIATED EMISSION AND BANDEDGE MEASUREMENT	21
3.1.1 LIMITS OF RADIATED EMISSION AND BANDEDGE MEASUREMENT.....	21
3.1.2 LIMITS OF UNWANTED EMISSION.....	21
3.1.3 TEST INSTRUMENTS.....	22
3.1.4 TEST PROCEDURES	23
3.1.5 DEVIATION FROM TEST STANDARD	23
3.1.6 TEST SETUP	24
3.1.7 EUT OPERATING CONDITION	25
3.1.8 TEST RESULTS	26
3.2 CONDUCTED EMISSION MEASUREMENT	110
3.2.1 LIMITS OF CONDUCTED EMISSION MEASUREMENT	110
3.2.2 TEST INSTRUMENTS.....	110
3.2.3 TEST PROCEDURES	110
3.2.4 DEVIATION FROM TEST STANDARD	111
3.2.5 TEST SETUP	111
3.2.6 EUT OPERATING CONDITIONS	111
3.2.7 TEST RESULTS	112
3.3 MAXIMUM CONDUCTED OUTPUT POWER MEASUREMENT	114
3.3.1 LIMITS OF MAXIMUM CONDUCTED OUTPUT POWER MEASUREMENT	114
3.3.2 TEST SETUP	115
3.3.3 TEST INSTRUMENTS.....	115



3.3.4	TEST PROCEDURE	116
3.3.5	DEVIATION FROM TEST STANDARD	118
3.3.6	EUT OPERATING CONDITIONS	118
3.3.7	TEST RESULTS	119
3.4	MAXIMUM POWER SPECTRAL DENSITY MEASUREMENT	120
3.4.1	LIMITS OF MAXIMUM POWER SPECTRAL DENSITY MEASUREMENT	120
3.4.2	TEST SETUP	120
3.4.3	TEST INSTRUMENTS	120
3.4.4	TEST PROCEDURES	121
3.4.5	DEVIATION FROM TEST STANDARD	121
3.4.6	EUT OPERATING CONDITIONS	121
3.4.7	TEST RESULTS	122
3.5	AUTOMATICALLY DISCONTINUE TRANSMISSION	123
3.5.1	LIMIT OF AUTOMATICALLY DISCONTINUE TRANSMISSION	123
3.5.2	TEST INSTRUMENTS	123
3.5.3	TEST RESULT	123
3.6	ANTENNA REQUIREMENTS	124
3.6.1	STANDARD APPLICABLE	124
3.6.2	ANTENNA CONNECTED CONSTRUCTION	124
3.6.3	ANTENNA GAIN	124
4	PHOTOGRAPHS OF THE TEST CONFIGURATION	124
5	MODIFICATIONS RECORDERS FOR ENGINEERING CHANGES TO THE EUT BY THE LAB125	



BUREAU
VERITAS

Test Report No.: W7L-240507W001RF03

RELEASE CONTROL RECORD

ISSUE NO.	REASON FOR CHANGE	DATE ISSUED
W7L-240507W001RF03	Original release	May. 24, 2024



1 SUMMARY OF TEST RESULTS

The EUT has been tested according to the following specifications:

APPLIED STANDARD: FCC PART 15, SUBPART E		
STANDARD SECTION	TEST TYPE AND LIMIT	RESULT
15.407(b)(9)	AC Power Conducted Emission	Compliance
15.407(b) (1/2/3/4/5)	Radiated Emission & Band Edge Measurement	Compliance
15.407(a/1/2/3)	Maximum conducted output Power	Compliance
15.407(a/1/2/3)	Peak Power Spectral Density	Compliance
15.407(a)(2)(12)	26 dB Bandwidth	Compliance
15.407(e)	6 dB Bandwidth	Compliance
15.203	Antenna Requirement	Compliance

NOTE:

1. Except the data of RSE and Band Edge Measurement, other data please refer to Appendix C.



1.1 MEASUREMENT UNCERTAINTY

Where relevant, the following measurement uncertainty levels have been estimated for tests performed on the EUT as specified in CISPR 16-4-2:

MEASUREMENT	UNCERTAINTY
AC Power Conducted emissions	±2.70dB
Radiated emissions (9KHz~30MHz)	±2.68dB
Radiated emissions (30MHz~1GHz)	±4.98dB
Radiated emissions (1GHz ~6GHz)	±4.70dB
Radiated emissions (6GHz ~18GHz)	±4.60dB
Radiated emissions (18GHz ~40GHz)	±4.12dB
Conducted emissions	±4.01dB
Occupied Channel Bandwidth	±43.58KHz
Conducted Output power	±2.06dB
Power Spectral Density	±0.85 dB

This uncertainty represents an expanded uncertainty expressed at approximately the 95% confidence level using a coverage factor of $k = 2$.



2 GENERAL INFORMATION

2.1 GENERAL DESCRIPTION OF EUT

PRODUCT	Tablet Computer
BRAND NAME	Redmi
MODEL NAME	24075RP89G
NOMINAL VOLTAGE	5.0Vdc(adapter or host equipment) 3.84Vdc (Li-ion, battery)
MODULATION	OFDM
TRANSFER RATE	802.11a: 54.0/ 48.0/ 36.0/ 24.0/ 18.0/ 12.0/ 9.0/ 6.0Mbps 802.11n: up to 150.0Mbps 802.11ac: up to 433.3Mbps
OPERATING FREQUENCY	5180 ~ 5240MHz, 5260 ~ 5320MHz, 5500 ~ 5720MHz, 5745 ~ 5825MHz
NUMBER OF CHANNEL	5180 ~ 5240MHz: 4 for 802.11a, 802.11n/ac/ax (20MHz) 2 for 802.11n/ac(40MHz) 1 for 802. 802.11ac (80MHz)/ 5260 ~ 5320MHz: 4 for 802.11a, 802.11n/ac/ax (20MHz) 2 for 802.11n/ac (40MHz) 1 for 802.11ac (80MHz) 5500 ~ 5720MHz: 12 for 802.11a, 802.11n/ac (20MHz)/ 6 for 802.11n/ac (40MHz) 3 for 802.11ac (80MHz) 5745 ~ 5825MHz: 5 for 802.11a, 802.11n/ac (20MHz) 2 for 802.11n/ac (40MHz) 1 for 802.11ac (80MHz)
MAX. OUTPUT POWER	50.35 mW for 5180 ~ 5240MHz 52.12 mW for 5260 ~ 5320MHz 47.21 mW for 5500 ~ 5720MHz 43.05 mW for 5745 ~ 5825MHz
ANTENNA TYPE	PIFA Antenna
ANTENNA GAIN	-1.2dBi for 5180 ~ 5240MHz -0.3dBi for 5260 ~ 5320MHz 0.4dBi for 5500 ~ 5720MHz -1dBi for 5745 ~ 5825MHz
HW VERSION	13510N85
SW VERSION	Xiaomi HyperOS 1.0



I/O PORTS	Refer to user's manual
CABLE SUPPLIED	USB cable1: non-shielded cable, with w/o ferrite core, 1.0 meter USB cable2: non-shielded cable, with w/o ferrite core, 1.0 meter USB cable3: non-shielded cable, with w/o ferrite core, 1.0 meter USB cable4: non-shielded cable, with w/o ferrite core, 1.0 meter

NOTE:

1. For a more detailed features description, please refer to the manufacturer's specifications or the user's manual.
2. The EUT incorporates a SISO function. Physically, the EUT provides one completed transmitter and one receiver.

MODULATION MODE	TX FUNCTION
802.11a	1TX /1RX
802.11n/802.11ac (20MHz)	1TX /1RX
802.11n/802.11ac (40MHz)	1TX /1RX
802.11ac (80MHz)	1TX /1RX

3. For the test results, the EUT had been tested with all conditions. But only the worst case was shown in the test report.
4. Antenna gain and EUT conducted cable loss are provided by the customer, and the laboratory will record the results based on these items that involve these two parameters.



2.2 DESCRIPTION OF TEST MODES

FOR 5180 ~ 5240MHz

4 channels are provided for 802.11a, 802.11n, 802.11ac (20MHz)

CHANNEL	FREQUENCY	CHANNEL	FREQUENCY
36	5180 MHz	44	5220 MHz
40	5200 MHz	48	5240 MHz

2 channels are provided for 802.11n, 802.11ac (40MHz):

CHANNEL	FREQUENCY	CHANNEL	FREQUENCY
38	5190 MHz	46	5230 MHz

1 channel is provided for 802.11ac (80MHz):

CHANNEL	FREQUENCY	CHANNEL	FREQUENCY
42	5210 MHz		

FOR 5260 ~ 5320MHz

4 channels are provided for 802.11a, 802.11n, 802.11ac (20MHz):

CHANNEL	FREQUENCY	CHANNEL	FREQUENCY
52	5260 MHz	60	5300 MHz
56	5280 MHz	64	5320 MHz

2 channels are provided for 802.11n, 802.11ac (40MHz):

CHANNEL	FREQUENCY	CHANNEL	FREQUENCY
54	5270 MHz	62	5310 MHz

1 channel is provided for 802.11ac (80MHz):

CHANNEL	FREQUENCY	CHANNEL	FREQUENCY
58	5290 MHz		



FOR 5500 ~ 5720MHz

12 channels are provided for 802.11a, 802.11n, 802.11ac (20MHz):

CHANNEL	FREQUENCY	CHANNEL	FREQUENCY
100	5500 MHz	124	5620MHz
104	5520 MHz	128	5640MHz
108	5540 MHz	132	5660 MHz
112	5560 MHz	136	5680 MHz
116	5580 MHz	140	5700 MHz
120	5600 MHz	144	5720 MHz

6 channels are provided for 802.11n, 802.11ac (40MHz):

CHANNEL	FREQUENCY	CHANNEL	FREQUENCY
102	5510 MHz	126	5630MHz
110	5550 MHz	134	5670 MHz
118	5590 MHz	142	5710 MHz

3 channel is provided for 802.11ac (80MHz):

CHANNEL	FREQUENCY	CHANNEL	FREQUENCY
106	5530 MHz	138	5690 MHz
122	5610 MHz		



FOR 5745 ~ 5825MHz

5 channels are provided for 802.11a, 802.11n, 802.11ac (20MHz):

CHANNEL	FREQUENCY	CHANNEL	FREQUENCY
149	5745 MHz	161	5805 MHz
153	5765 MHz	165	5825 MHz
157	5785 MHz		

2 channels are provided for 802.11n, 802.11ac (40MHz):

CHANNEL	FREQUENCY	CHANNEL	FREQUENCY
142	5710 MHz	159	5795 MHz
151	5755 MHz		

1 channel is provided for 802.11ac (80MHz):

CHANNEL	FREQUENCY
155	5775 MHz



2.2.1 TEST MODE APPLICABILITY AND TESTED CHANNEL DETAIL

EUT CONFIGURE MODE	APPLICABLE TO				DESCRIPTION
	RE≥1G	RE<1G	PLC	APCM	
A	√	√	√	-	Powered by Adapter with wifi(5G) link
B	-	-	-	√	Powered by Battery with wifi(5G) link
C	-	-	-	-	Powered by USB with wifi(5G) link

Where **RE≥1G**: Radiated Emission above 1GHz **RE<1G**: Radiated Emission below 1GHz
PLC: Power Line Conducted Emission **APCM**: Antenna Port Conducted Measurement

NOTE:
The EUT had been pre-tested on the positioned of each 3 axis. The worst case was found when positioned on **X-plane**.
NOTE: “-” means no effect

RADIATED EMISSION TEST (BELOW 1GHz):

- Pre-Scan has been conducted to determine the worst-case mode from all possible combinations between available modulations, data rates and antenna ports (if EUT with antenna diversity architecture).
- The following channel(s) was (were) selected for the final test as listed below.

EUT CONFIGURE MODE	MODE	FREQ. BAND (MHz)	AVAILABLE CHANNEL	TESTED CHANNEL	MODULATION	DATA RATE (Mbps)
A	802.11ac (80MHz)	5180-5240	42	42	OFDM	MCS0



RADIATED EMISSION TEST (ABOVE 1GHz):

- Pre-Scan has been conducted to determine the worst-case mode from all possible combinations between available modulations, data rates and antenna ports (if EUT with antenna diversity architecture).
- The following channel(s) was (were) selected for the final test as listed below.

EUT CONFIGURE MODE	MODE	FREQ. BAND (MHz)	AVAILABLE CHANNEL	TESTED CHANNEL	MODULATION	DATA RATE (Mbps)
A	802.11a	5180-5240	36 to 48	36, 40, 48	OFDM	6.0
A	802.11n/ac (20MHz)		36 to 48	36, 40, 48	OFDM	MCS0
A	802.11n/ac (40MHz)		38 to 46	38, 46	OFDM	MCS0
A	802.11ac (80MHz)		42	42	OFDM	MCS0
A	802.11a	5260-5320	52 to 64	52, 60, 64	OFDM	6.0
A	802.11n/ac (20MHz)		52 to 64	52, 60, 64	OFDM	MCS0
A	802.11n/ac/ (40MHz)		54 to 62	54, 62	OFDM	MCS0
A	802.11ac (80MHz)		58	58	OFDM	MCS0
A	802.11a	5500-5720	100 to 144	100, 116, 144	OFDM	6.0
A	802.11n/ac (20MHz)		100 to 144	100, 116, 144	OFDM	MCS0
A	802.11n/ac (40MHz)		102 to 142	102, 110, 142	OFDM	MCS0
A	802.11ac (80MHz)		106 to 138	106, 122, 138	OFDM	MCS0
A	802.11a	5745-5825	149 to 165	149, 157,165	OFDM	6.0
A	802.11n/ac (20MHz)		149 to 165	149, 157,165	OFDM	MCS0
A	802.11n/ac (40MHz)		151 to 159	151, 159	OFDM	MCS0
A	802.11ac (80MHz)		155	155	OFDM	MCS0



POWER LINE CONDUCTED EMISSION TEST:

- Pre-Scan has been conducted to determine the worst-case mode from all possible combinations between available modulations, data rates and antenna ports (if EUT with antenna diversity architecture).
- The following channel(s) was (were) selected for the final test as listed below.

EUT CONFIGURE MODE	MODE	FREQ. BAND (MHz)	AVAILABLE CHANNEL	TESTED CHANNEL	MODULATION	DATA RATE (Mbps)
A	802.11ac (80MHz)	5180-5240	42	42	OFDM	MCS0

BANDEDGE MEASUREMENT:

- Pre-Scan has been conducted to determine the worst-case mode from all possible combinations between available modulations, data rates and antenna ports (if EUT with antenna diversity architecture).
- The following channel(s) was (were) selected for the final test as listed below.

EUT CONFIGURE MODE	MODE	FREQ. BAND (MHz)	AVAILABLE CHANNEL	TESTED CHANNEL	MODULATION	DATA RATE (Mbps)
A	802.11a	5180-5240	36 to 48	36, 40, 48	OFDM	6.0
A	802.11n/ac (20MHz)		36 to 48	36, 40, 48	OFDM	MCS0
A	802.11n/ac (40MHz)		38 to 46	38, 46	OFDM	MCS0
A	802.11ac (80MHz)		42	42	OFDM	MCS0
A	802.11a	5260-5320	52 to 64	52, 60, 64	OFDM	6.0
A	802.11n/ac (20MHz)		52 to 64	52, 60, 64	OFDM	MCS0
A	802.11n/ac (40MHz)		54 to 62	54, 62	OFDM	MCS0
A	802.11ac (80MHz)		58	58	OFDM	MCS0
A	802.11a	5500-5720	100 to 144	100, 116, 144	OFDM	6.0
A	802.11n/ac (20MHz)		100 to 144	100, 116, 144	OFDM	MCS0
A	802.11n/ac (40MHz)		102 to 142	102, 110, 142	OFDM	MCS0
A	802.11ac (80MHz)		106 to 138	106, 122, 138	OFDM	MCS0
A	802.11a	5745-5825	149 to 165	149, 157, 165	OFDM	6.0
A	802.11n/ac (20MHz)		149 to 165	149, 157, 165	OFDM	MCS0
A	802.11n/ac (40MHz)		151 to 159	151, 159	OFDM	MCS0
A	802.11ac (80MHz)		155	155	OFDM	MCS0



ANTENNA PORT CONDUCTED MEASUREMENT:

- This item includes all test values of each mode, but only includes spectrum plot of worst value of each mode.
- Pre-Scan has been conducted to determine the worst-case mode from all possible combinations between available modulations, data rates and antenna ports (if EUT with antenna diversity architecture).
- The following channel(s) was (were) selected for the final test as listed below.

EUT CONFIGURE MODE	MODE	FREQ. BAND (MHz)	AVAILABLE CHANNEL	TESTED CHANNEL	MODULATION	DATA RATE (Mbps)
A	802.11a	5180-5240	36 to 48	36, 40, 48	OFDM	6.0
A	802.11n/ac (20MHz)		36 to 48	36, 40, 48	OFDM	MCS0
A	802.11n/ac (40MHz)		38 to 46	38, 46	OFDM	MCS0
A	802.11ac (80MHz)		42	42	OFDM	MCS0
A	802.11a	5260-5320	52 to 64	52, 60, 64	OFDM	6.0
A	802.11n/ac (20MHz)		52 to 64	52, 60, 64	OFDM	MCS0
A	802.11n/ac (40MHz)		54 to 62	54, 62	OFDM	MCS0
A	802.11ac (80MHz)		58	58	OFDM	MCS0
A	802.11a	5500-5720	100 to 144	100, 116, 144	OFDM	6.0
A	802.11n/ac (20MHz)		100 to 144	100, 116, 144	OFDM	MCS0
A	802.11n/ac (40MHz)		102 to 142	102, 110, 142	OFDM	MCS0
A	802.11ac (80MHz)		106 to 138	106, 122, 138	OFDM	MCS0
A	802.11a	5745-5825	149 to 165	149, 157,165	OFDM	6.0
A	802.11n/ac (20MHz)		149 to 165	149, 157,165	OFDM, OFDMA	MCS0
A	802.11n/ac (40MHz)		151 to 159	151, 159	OFDM	MCS0
A	802.11ac (80MHz)		155	155	OFDM	MCS0



BUREAU
VERITAS

Test Report No.: W7L-240507W001RF03

TEST CONDITION:

APPLICABLE TO	ENVIRONMENTAL CONDITIONS	INPUT POWER	TESTED BY
RE<1G	23deg. C, 70%RH	DC 5V By Adapter	Jace Hu
RE≥1G	23deg. C, 70%RH	DC 5V By Adapter	Jace Hu
PLC	25deg. C, 52%RH	DC 5V By Adapter	James Fu
APCM	25deg. C, 60%RH	DC 3.84V By DC Supply	James Fu



2.3 DUTY CYCLE OF TEST SIGNAL

Please Refer to Appendix C.



2.4 DESCRIPTION OF SUPPORT UNITS

The EUT has been tested as an independent unit together with other necessary accessories or support units. The following support units or accessories were used to form a representative test configuration during the tests.

NO.	PRODUCT	BRAND	MODEL NO.	SERIAL NO.	FCC ID
1	Desktop	Lenovo	M73 SFF	PC04GRQV	N/A
2	Desktop	Lenovo	M73 SFF	PC06CS27	N/A
3	Laptop	Lenovo	ThinkpadL440	R90FTFKN	N/A
4	DC source	Kikusui/JP	PMX18-5A	0000001	N/A

NO.	SIGNAL CABLE DESCRIPTION OF THE ABOVE SUPPORT UNITS
1	AC Line: Unshielded, Detachable 1.5m
2	AC Line: Unshielded, Detachable 1.5m
3	AC Line: Unshielded, Detachable 1.5m
4	DC Line: Unshielded, Detachable 1.0m



2.4.1 CONFIGURATION OF SYSTEM UNDER TEST

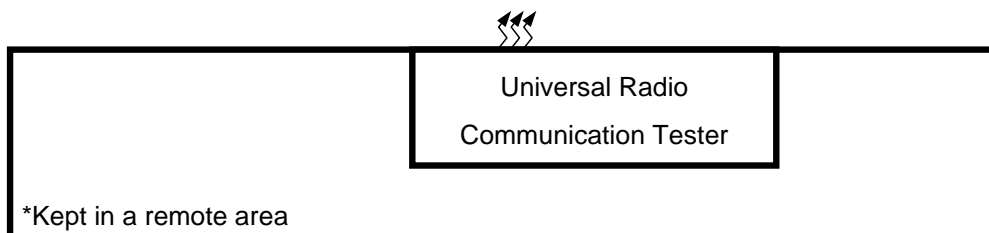
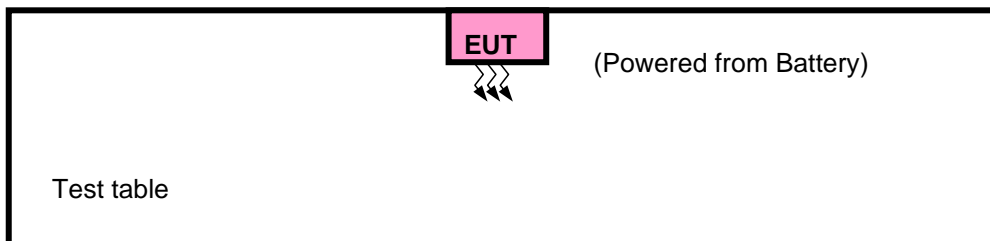
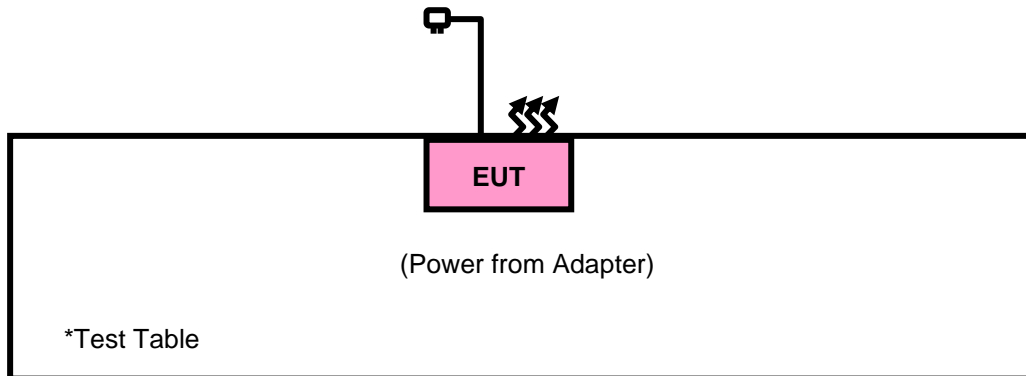



2.5 GENERAL DESCRIPTION OF APPLIED STANDARDS

The EUT is a RF Product. According to the specifications of the manufacturer, it must comply with the requirements of the following standards:

FCC Part 15, Subpart E (15.407)

KDB 789033 D02 General U-NII Test Procedures New Rules v02r01

ANSI C63.10-2020

All test items have been performed and recorded as per the above standards.

NOTE: The EUT is also considered as a kind of computer peripheral, because the connection to computer is necessary for typical use. It has been verified to comply with the requirements of FCC Part 15, Subpart B, Class B (Certification). The test report has been issued separately.



3 TEST TYPES AND RESULTS

3.1 RADIATED EMISSION AND BANDEDGE MEASUREMENT

3.1.1 LIMITS OF RADIATED EMISSION AND BANDEDGE MEASUREMENT

Radiated emissions which fall in the restricted bands must comply with the radiated emission limits specified as below table:

FREQUENCIES (MHz)	FIELD STRENGTH (microvolts/meter)	MEASUREMENT DISTANCE (meters)
0.009 ~ 0.490	2400/F(kHz)	300
0.490 ~ 1.705	24000/F(kHz)	30
1.705 ~ 30.0	30	30
30 ~ 88	100	3
88 ~ 216	150	3
216 ~ 960	200	3
Above 960	500	3

NOTE:

1. The lower limit shall apply at the transition frequencies.
2. Emission level (dBuV/m) = 20 log Emission level (uV/m).
3. For frequencies above 1000MHz, the field strength limits are based on average detector, however, the peak field strength of any emission shall not exceed the maximum permitted average limits, specified above by more than 20dB under any condition of modulation.

3.1.2 LIMITS OF UNWANTED EMISSION

RESTRICTED BANDS	APPLICABLE TO	LIMIT	
	789033 D02 General UNII Test Procedures New Rules v02r01	FIELD STRENGTH AT 3m (dBµV/m)	
	PK : 74	AV : 54	
OUT OF THE RESTRICTED BANDS	APPLICABLE TO	EIRP LIMIT (dBm/MHz)	EQUIVALENT FIELD STRENGTH AT 3m (dBµV/m)
	15.407(b)(1)	PK : -27	PK : 68.2
	15.407(b)(2)		
	15.407(b)(3)		
	15.407(b)(4)	See note 2 (FCC 16-24)	



NOTE: The following formula is used to convert the equipment isotropic radiated power (eirp) to field strength:

$$E = \frac{1000000 \sqrt{30P}}{3} \text{ } \mu\text{V/m, where P is the eirp (Watts).}$$

2. All emissions shall be limited to a level of -27 dBm/MHz at 75 MHz or more above or below the band edge increasing linearly to 10 dBm/MHz at 25 MHz above or below the band edge, and from 25 MHz above or below the band edge increasing linearly to a level of 15.6 dBm/MHz at 5 MHz above or below the band edge, and from 5 MHz above or below the band edge increasing linearly to a level of 27 dBm/MHz at the band edge.

3.1.3 TEST INSTRUMENTS

Equipment	Manufacturer	Model No.	Serial No.	Last Cal.	Next Cal.
3m Semi-anechoic Chamber	ETS-LINDGREN	9m*6m*6m	Euroshieldpn-CT0001143-1216	Nov. 14,23	Nov. 13,26
Bilog Antenna	ETS-LINDGREN	3143B	00161965	Feb. 18,24	Feb. 17,25
Horn Antenna	ETS-LINDGREN	3117	00168692	Feb. 18,24	Feb. 17,25
Horn Antenna (18GHz-40GHz)	N/A	QWH-SL-18-40-K-SG/QMS-00361	15433	Sep.04, 23	Sep.03, 24
Test Software	E3	V 9.160323	N/A	N/A	N/A
Test Software	JS1120-3	3.2.06	N/A	N/A	N/A
10dB Attenuator	JFW/USA	50HF-010-SMA	N/A	May. 06,24	May. 05,25
MXE EMI Receiver	KEYSIGHT	N9038A-544	MY54450026	Mar. 28,24	Mar. 27,25
Signal Pre-Amplifier	EMSI	EMC 9135	980249	May. 06,24	May. 05,25
Signal Pre-Amplifier	EMSI	EMC 012645B	980257	May.10,23	May.09,24
Signal Pre-Amplifier	EMSI	EMC 012645B	980257	May.09,24	May.08,25
Signal Pre-Amplifier	EMSI	EMC 184045B	980259	Feb. 17,24	Feb. 16,25
DC Source	Kikusui/JP	PMX18-5A	0000001	Aug. 12,23	Aug. 11,24
Power Meter	Anritsu	ML2495A	1506002	Feb. 14,24	Feb. 13,25
Power Sensor	Anritsu	MA2411B	1339352	Feb. 14,24	Feb. 13,25
Loop Antenna	Schwarzbeck	FMZB 1519B	00173	Sep.03,23	Sep.02,24

- NOTE:**
1. The calibration interval of the above test instruments is 12 months or 36 months, and the calibrations are traceable to CEPREI/CHINA, GRGT/CHINA, and NIM/CHINA.
 2. The test was performed in the 3m Chamber.
 3. The FCC Site Registration No. is 525120; The Designation No. is CN1171.



3.1.4 TEST PROCEDURES

- a. The EUT was placed on the top of a rotating table 0.8 meters (for below 1GHz) / 1.5 meters (for above 1GHz) above the ground at 3-meter chamber room for test. The table was rotated 360 degrees to determine the position of the highest radiation.
- b. The EUT was set 3 meters away from the interference-receiving antenna, which was mounted on the top of a variable-height antenna tower.
- c. The antenna is a broadband antenna, and its height varies from one meter to four meters above the ground to determine the maximum value of the field strength. Both horizontal and vertical polarizations of the antenna are set to make the measurement.
- d. For each suspected emission, the EUT was arranged to its worst case and then the antenna was tuned to heights from 1 meter to 4 meters and the rotatable table was turned from 0 degrees to 360 degrees to find the maximum reading.
- e. The test-receiver system was set to Peak Detect Function and Specified Bandwidth with Maximum Hold Mode.
- f. If the emission level of the EUT in peak mode was 10dB lower than the limit specified, then testing could be stopped and the peak values of the EUT would be reported. Otherwise the emissions that did not have 10dB margin would be re-tested one by one using peak, quasi-peak or average method as specified and then reported in a data sheet.

NOTE:

1. The resolution bandwidth and video bandwidth of test receiver/spectrum analyzer is 120kHz for Peak detection (PK) and Quasi-peak detection (QP) at frequency below 1GHz.
2. The resolution bandwidth of test receiver/spectrum analyzer is 1MHz and video bandwidth is 3MHz for Peak detection at frequency above 1GHz.
3. The resolution bandwidth of test receiver/spectrum analyzer is 1MHz and the video bandwidth is 3MHz for RMS Average (Duty cycle < 98%) for Average detection (AV) at frequency above 1GHz, then the measurement results was added to a correction factor ($10 \log(1/\text{duty cycle})$).
4. The resolution bandwidth of test receiver/spectrum analyzer is 1MHz and the video bandwidth is 10Hz (Duty cycle $\geq 98\%$) for Average detection (AV) at frequency above 1GHz.
5. All modes of operation were investigated, and the worst-case emissions are reported.

3.1.5 DEVIATION FROM TEST STANDARD

No deviation.



3.1.6 TEST SETUP

<Frequency Range 9KHz~30MHz >

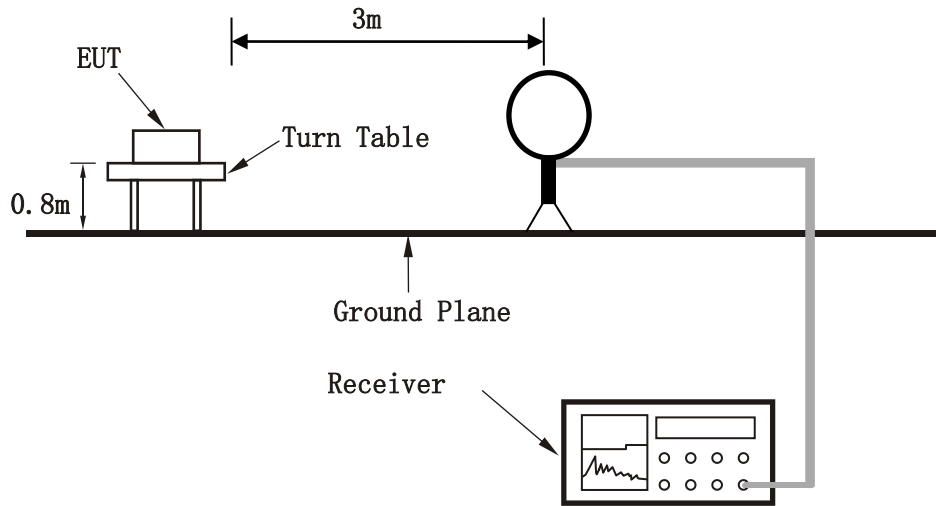

< Frequency Range 30MHz~1GHz >

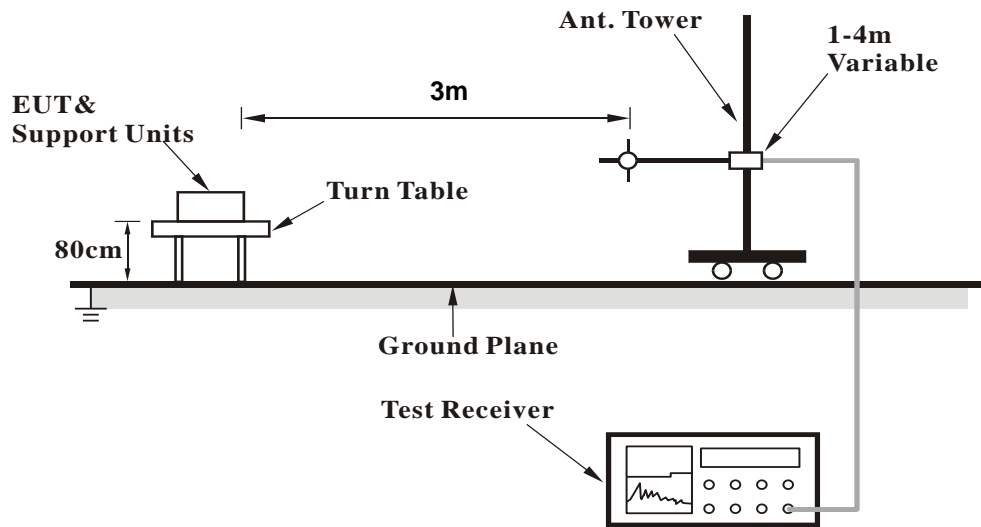



<Frequency Range above 1GHz>

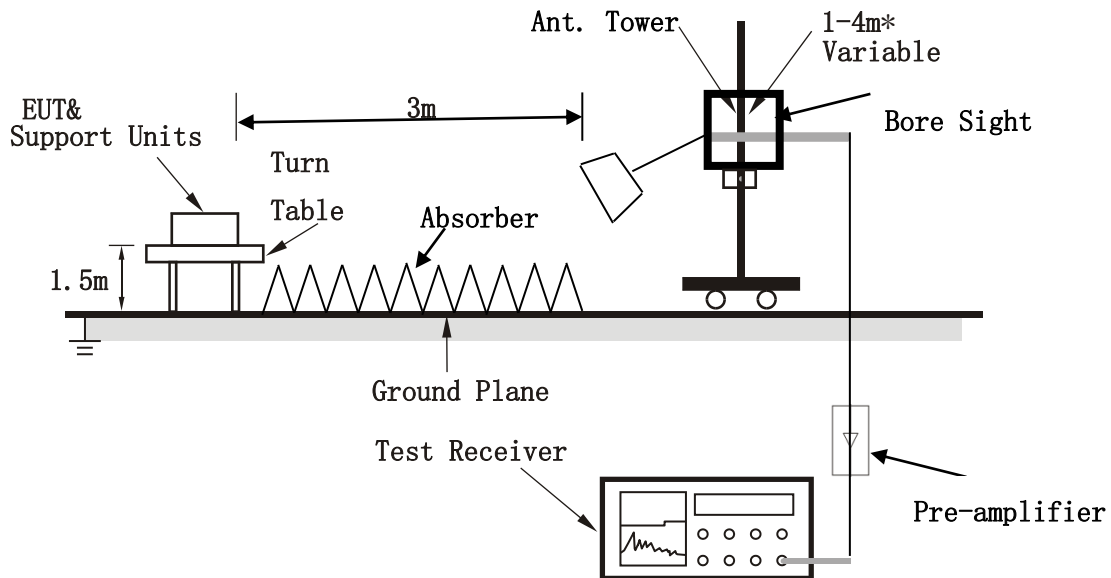

Note: Above 1G is a directional antenna

Depending on the EUT height and the antenna 3dB beamwidth both, refer to section 7.3 of CISPR 16-2-3.

For the actual test configuration, please refer to the attached file (Test Setup Photo).

3.1.7 EUT OPERATING CONDITION

- Set the EUT under full load condition and placed it on a testing table.
- Set the transmitter part of EUT under transmission condition continuously at specific channel frequency.
- The necessary accessories enable the EUT in full functions.



3.1.8 TEST RESULTS

NOTE : The 9K~30MHz amplitude of spurious emissions attenuated more than 20 dB below the permissible value is not required in the report.

30 MHz – 1GHz data:

Band 1

802.11ac (80MHz):

CHANNEL	TX Channel 42	DETECTOR FUNCTION	Quasi-Peak (QP)
FREQUENCY RANGE	30MHz ~ 1GHz		

ANTENNA POLARITY & TEST DISTANCE: HORIZONTAL AT 3 M										
FREQ. (MHz)	EMISSION LEVEL (dBuV/m)	READ LEVEL (dBuV)	LIMIT (dBuV/m)	MARGIN (dB)	ANTENNA FACTOR (dB /m)	CABLE LOSS (dB)	PREAMP FACTOR (dB)	ANTENNA HEIGHT (cm)	TABLE ANGLE (Degree)	REMARK
30.97	22.25	33.51	40	-17.75	19.97	6.14	37.37	100	360	QP
175.5	21.08	39.45	43.5	-22.42	11.52	6.83	36.72	100	360	QP
251.16	28.23	44.07	46	-17.77	13.62	7.15	36.61	100	360	QP
297.72	27.32	42.35	46	-18.68	14.27	7.31	36.61	100	360	QP
353.01	26.38	40.03	46	-19.62	15.63	7.45	36.73	100	360	QP
818.61	30.92	36.21	46	-15.08	23.76	8.63	37.68	100	360	QP

REMARKS:

1. Emission level (dBuV/m) = Read level (dBuV) + Correction Factor (dB/m).
2. Correction Factor (dB/m) = Antenna Factor (dB/m) + Cable Factor (dB).
3. The other emission levels were very low against the limit.
4. Margin value = Emission level – Limit value.

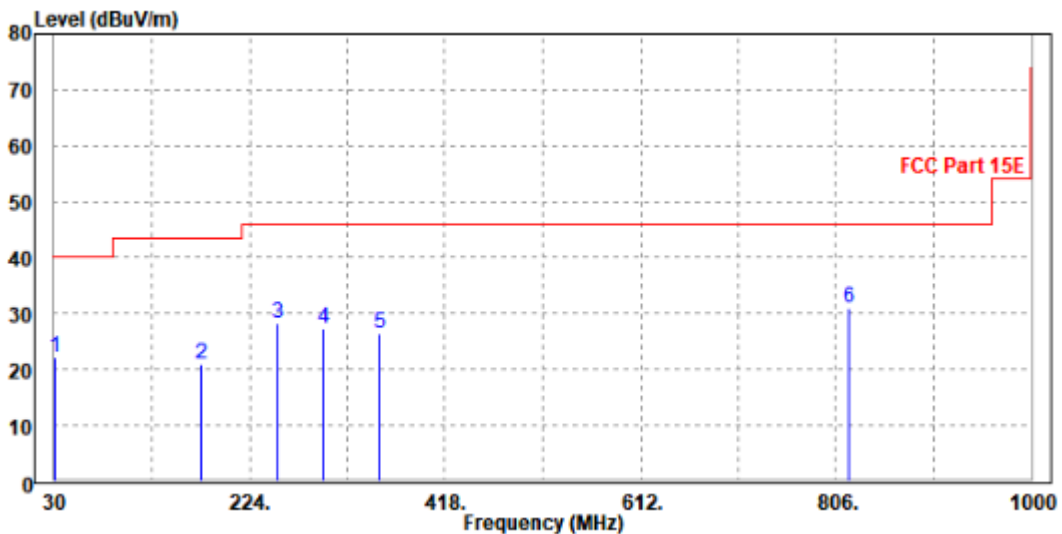



CHANNEL	Channel 42	DETECTOR FUNCTION	Quasi-Peak (QP)
FREQUENCY RANGE	30MHz ~ 1GHz		

ANTENNA POLARITY & TEST DISTANCE: VERTICAL AT 3 M										
FREQ. (MHz)	EMISSION LEVEL (dBuV/m)	READ LEVEL (dBuV)	LIMIT (dBuV/m)	MARGIN (dB)	ANTENNA FACTOR (dB /m)	CABLE LOSS (dB)	PREAMP FACTOR (dB)	ANTENNA HEIGHT (cm)	TABLE ANGLE (Degree)	REMARK
30.97	24.51	35.5	40	-15.49	20.24	6.14	37.37	100	0	QP
79.47	22.58	45.28	40	-17.42	7.87	6.44	37.01	100	0	QP
122.15	27.3	46.36	43.5	-16.2	11.24	6.64	36.94	100	0	QP
255.04	25.87	41.25	46	-20.13	14.06	7.17	36.61	100	0	QP
344.28	24.26	37.61	46	-21.74	15.93	7.43	36.71	100	0	QP
692.51	29.78	35.67	46	-16.22	23	8.37	37.26	100	0	QP

REMARKS:

1. Emission level (dBuV/m) = Read level (dBuV) + Correction Factor (dB/m).
2. Correction Factor (dB/m) = Antenna Factor (dB/m) + Cable Factor (dB).
3. The other emission levels were very low against the limit.
4. Margin value = Emission level – Limit value.

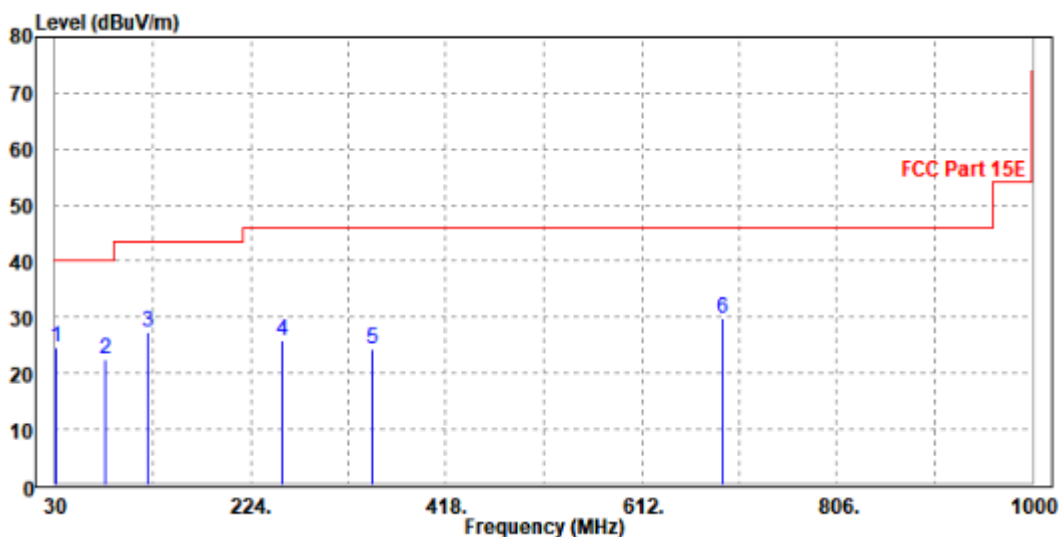



ABOVE 1GHz WORST-CASE DATA:

Note: For higher frequency, the emission is too low to be detected.

Band 1

802.11a

CHANNEL	TX Channel 36	DETECTOR FUNCTION	Peak (PK)
FREQUENCY RANGE	1GHz ~ 40GHz		Average (AV)

ANTENNA POLARITY & TEST DISTANCE: HORIZONTAL AT 3 M

FREQ. (MHz)	EMISSION LEVEL (dBuV/m)	READ LEVEL (dBuV)	LIMIT (dBuV/m)	MARGIN (dB)	ANTENNA FACTOR (dB /m)	CABLE LOSS (dB)	PREAMP FACTOR (dB)	ANTENNA HEIGHT (cm)	TABLE ANGLE (Degree)	REMARK
5150.000	56.83	57.92	74.00	-17.17	34.26	11.17	46.52	100	190	Peak
5150.000	48.15	49.24	54.00	-5.85	34.26	11.17	46.52	100	190	Average
5180.000	104.74	105.80	/	/	34.27	11.20	46.53	100	190	Peak
5180.000	97.20	98.26	/	/	34.27	11.20	46.53	100	190	Average
5350.000	52.77	53.62	74.00	-21.23	34.34	11.39	46.58	100	190	Peak
5350.000	45.21	46.06	54.00	-8.79	34.34	11.39	46.58	100	190	Average

ANTENNA POLARITY & TEST DISTANCE: VERTICAL AT 3 M

FREQ. (MHz)	EMISSION LEVEL (dBuV/m)	READ LEVEL (dBuV)	LIMIT (dBuV/m)	MARGIN (dB)	ANTENNA FACTOR (dB /m)	CABLE LOSS (dB)	PREAMP FACTOR (dB)	ANTENNA HEIGHT (cm)	TABLE ANGLE (Degree)	REMARK
5150.000	55.42	56.35	74.00	-18.58	34.42	11.17	46.52	100	0	Peak
5150.000	46.64	47.57	54.00	-7.36	34.42	11.17	46.52	100	0	Average
5180.000	102.00	102.89	/	/	34.44	11.20	46.53	100	0	Peak
5180.000	93.61	94.50	/	/	34.44	11.20	46.53	100	0	Average
5350.000	52.42	53.03	74.00	-21.58	34.58	11.39	46.58	100	0	Peak
5350.000	45.52	46.13	54.00	-8.48	34.58	11.39	46.58	100	0	Average

REMARKS:

- Emission Level = Read Level+ Antenna Factor + Cable Loss- Preamp Factor
Margin value = Emission level – Limit value.
- 5180MHz: Fundamental frequency.



CHANNEL	TX Channel 40	DETECTOR FUNCTION	Peak (PK)
FREQUENCY RANGE	1GHz ~ 40GHz		Average (AV)

ANTENNA POLARITY & TEST DISTANCE: HORIZONTAL AT 3 M										
FREQ. (MHz)	EMISSION LEVEL (dBuV/m)	READ LEVEL (dBuV)	LIMIT (dBuV/m)	MARGIN (dB)	ANTENNA FACTOR (dB /m)	CABLE LOSS (dB)	PREAMP FACTOR (dB)	ANTENNA HEIGHT (cm)	TABLE ANGLE (Degree)	REMARK
5150.000	54.14	55.23	74.00	-19.86	34.26	11.17	46.52	100	190	Peak
5150.000	46.20	47.29	54.00	-7.80	34.26	11.17	46.52	100	190	Average
5200.000	105.20	106.24	/	/	34.28	11.22	46.54	100	190	Peak
5200.000	98.07	99.11	/	/	34.28	11.22	46.54	100	190	Average
5350.000	52.90	53.75	74.00	-21.10	34.34	11.39	46.58	100	190	Peak
5350.000	45.14	45.99	54.00	-8.86	34.34	11.39	46.58	100	190	Average
ANTENNA POLARITY & TEST DISTANCE: VERTICAL AT 3 M										
FREQ. (MHz)	EMISSION LEVEL (dBuV/m)	READ LEVEL (dBuV)	LIMIT (dBuV/m)	MARGIN (dB)	ANTENNA FACTOR (dB /m)	CABLE LOSS (dB)	PREAMP FACTOR (dB)	ANTENNA HEIGHT (cm)	TABLE ANGLE (Degree)	REMARK
5150.000	55.42	56.35	74.00	-18.58	34.42	11.17	46.52	100	0	Peak
5150.000	45.41	46.34	54.00	-8.59	34.42	11.17	46.52	100	0	Average
5200.000	100.82	101.68	/	/	34.46	11.22	46.54	100	0	Peak
5200.000	93.31	94.17	/	/	34.46	11.22	46.54	100	0	Average
5350.000	55.23	55.84	74.00	-18.77	34.58	11.39	46.58	100	0	Peak
5350.000	45.25	45.86	54.00	-8.75	34.58	11.39	46.58	100	0	Average

REMARKS:

- Emission Level = Read Level+ Antenna Factor + Cable Loss- Preamp Factor
Margin value = Emission level – Limit value.
- 5200MHz: Fundamental frequency.



CHANNEL	TX Channel 48	DETECTOR FUNCTION	Peak (PK)
FREQUENCY RANGE	1GHz ~ 40GHz		Average (AV)

ANTENNA POLARITY & TEST DISTANCE: HORIZONTAL AT 3 M										
FREQ. (MHz)	EMISSION LEVEL (dBuV/m)	READ LEVEL (dBuV)	LIMIT (dBuV/m)	MARGIN (dB)	ANTENNA FACTOR (dB /m)	CABLE LOSS (dB)	PREAMP FACTOR (dB)	ANTENNA HEIGHT (cm)	TABLE ANGLE (Degree)	REMARK
5150.000	53.15	54.24	74.00	-20.85	34.26	11.17	46.52	100	190	Peak
5150.000	45.43	46.52	54.00	-8.57	34.26	11.17	46.52	100	190	Average
5240.000	104.27	105.25	/	/	34.30	11.27	46.55	100	190	Peak
5240.000	96.72	97.70	/	/	34.30	11.27	46.55	100	190	Average
5350.000	54.39	55.24	74.00	-19.61	34.34	11.39	46.58	100	190	Peak
5350.000	45.50	46.35	54.00	-8.50	34.34	11.39	46.58	100	190	Average
ANTENNA POLARITY & TEST DISTANCE: VERTICAL AT 3 M										
FREQ. (MHz)	EMISSION LEVEL (dBuV/m)	READ LEVEL (dBuV)	LIMIT (dBuV/m)	MARGIN (dB)	ANTENNA FACTOR (dB /m)	CABLE LOSS (dB)	PREAMP FACTOR (dB)	ANTENNA HEIGHT (cm)	TABLE ANGLE (Degree)	REMARK
5150.000	54.92	55.85	74.00	-19.08	34.42	11.17	46.52	100	0	Peak
5150.000	45.60	46.53	54.00	-8.40	34.42	11.17	46.52	100	0	Average
5240.000	100.59	101.38	/	/	34.49	11.27	46.55	100	0	Peak
5240.000	91.99	92.78	/	/	34.49	11.27	46.55	100	0	Average
5350.000	53.04	53.65	74.00	-20.96	34.58	11.39	46.58	100	0	Peak
5350.000	45.56	46.17	54.00	-8.44	34.58	11.39	46.58	100	0	Average

REMARKS:

- Emission Level = Read Level+ Antenna Factor + Cable Loss- Preamp Factor
Margin value = Emission level – Limit value.
- 5240MHz: Fundamental frequency.



802.11n (20MHz)

CHANNEL	TX Channel 36	DETECTOR FUNCTION	Peak (PK)
FREQUENCY RANGE	1GHz ~ 40GHz		Average (AV)

ANTENNA POLARITY & TEST DISTANCE: HORIZONTAL AT 3 M										
FREQ. (MHz)	EMISSION LEVEL (dBuV/m)	READ LEVEL (dBuV)	LIMIT (dBuV/m)	MARGIN (dB)	ANTENNA FACTOR (dB /m)	CABLE LOSS (dB)	PREAMP FACTOR (dB)	ANTENNA HEIGHT (cm)	TABLE ANGLE (Degree)	REMARK
5150.000	56.77	57.86	74.00	-17.23	34.26	11.17	46.52	100	190	Peak
5150.000	46.92	48.01	54.00	-7.08	34.26	11.17	46.52	100	190	Average
5180.000	102.66	103.72	/	/	34.27	11.20	46.53	100	190	Peak
5180.000	95.72	96.78	/	/	34.27	11.20	46.53	100	190	Average
5350.000	51.79	52.64	74.00	-22.21	34.34	11.39	46.58	100	190	Peak
5350.000	44.88	45.73	54.00	-9.12	34.34	11.39	46.58	100	190	Average
ANTENNA POLARITY & TEST DISTANCE: VERTICAL AT 3 M										
FREQ. (MHz)	EMISSION LEVEL (dBuV/m)	READ LEVEL (dBuV)	LIMIT (dBuV/m)	MARGIN (dB)	ANTENNA FACTOR (dB /m)	CABLE LOSS (dB)	PREAMP FACTOR (dB)	ANTENNA HEIGHT (cm)	TABLE ANGLE (Degree)	REMARK
5150.000	54.93	55.86	74.00	-19.07	34.42	11.17	46.52	100	0	Peak
5150.000	45.24	46.17	54.00	-8.76	34.42	11.17	46.52	100	0	Average
5180.000	100.69	101.58	/	/	34.44	11.20	46.53	100	0	Peak
5180.000	92.64	93.53	/	/	34.44	11.20	46.53	100	0	Average
5350.000	52.42	53.03	74.00	-21.58	34.58	11.39	46.58	100	0	Peak
5350.000	45.25	45.86	54.00	-8.75	34.58	11.39	46.58	100	0	Average

REMARKS:

- Emission Level = Read Level+ Antenna Factor + Cable Loss- Preamp Factor
Margin value = Emission level – Limit value.
- 5180MHz: Fundamental frequency.



CHANNEL	TX Channel 40	DETECTOR FUNCTION	Peak (PK)
FREQUENCY RANGE	1GHz ~ 40GHz		Average (AV)

ANTENNA POLARITY & TEST DISTANCE: HORIZONTAL AT 3 M										
FREQ. (MHz)	EMISSION LEVEL (dBuV/m)	READ LEVEL (dBuV)	LIMIT (dBuV/m)	MARGIN (dB)	ANTENNA FACTOR (dB /m)	CABLE LOSS (dB)	PREAMP FACTOR (dB)	ANTENNA HEIGHT (cm)	TABLE ANGLE (Degree)	REMARK
5150.000	52.54	53.63	74.00	-21.46	34.26	11.17	46.52	100	190	Peak
5150.000	45.62	46.71	54.00	-8.38	34.26	11.17	46.52	100	190	Average
5200.000	103.49	104.53	/	/	34.28	11.22	46.54	100	190	Peak
5200.000	95.73	96.77	/	/	34.28	11.22	46.54	100	190	Average
5350.000	52.19	53.04	74.00	-21.81	34.34	11.39	46.58	100	190	Peak
5350.000	45.28	46.13	54.00	-8.72	34.34	11.39	46.58	100	190	Average
ANTENNA POLARITY & TEST DISTANCE: VERTICAL AT 3 M										
FREQ. (MHz)	EMISSION LEVEL (dBuV/m)	READ LEVEL (dBuV)	LIMIT (dBuV/m)	MARGIN (dB)	ANTENNA FACTOR (dB /m)	CABLE LOSS (dB)	PREAMP FACTOR (dB)	ANTENNA HEIGHT (cm)	TABLE ANGLE (Degree)	REMARK
5150.000	51.70	52.63	74.00	-22.30	34.42	11.17	46.52	100	0	Peak
5150.000	45.39	46.32	54.00	-8.61	34.42	11.17	46.52	100	0	Average
5200.000	98.29	99.15	/	/	34.46	11.22	46.54	100	0	Peak
5200.000	91.18	92.04	/	/	34.46	11.22	46.54	100	0	Average
5350.000	52.44	53.05	74.00	-21.56	34.58	11.39	46.58	100	0	Peak
5350.000	45.35	45.96	54.00	-8.65	34.58	11.39	46.58	100	0	Average

REMARKS:

1. Emission Level = Read Level+ Antenna Factor + Cable Loss- Preamp Factor
Margin value = Emission level – Limit value.
2. 5200MHz: Fundamental frequency.



CHANNEL	TX Channel 48	DETECTOR FUNCTION	Peak (PK)
FREQUENCY RANGE	1GHz ~ 40GHz		Average (AV)

ANTENNA POLARITY & TEST DISTANCE: HORIZONTAL AT 3 M

FREQ. (MHz)	EMISSION LEVEL (dBuV/m)	READ LEVEL (dBuV)	LIMIT (dBuV/m)	MARGIN (dB)	ANTENNA FACTOR (dB /m)	CABLE LOSS (dB)	PREAMP FACTOR (dB)	ANTENNA HEIGHT (cm)	TABLE ANGLE (Degree)	REMARK
5150.000	53.36	54.45	74.00	-20.64	34.26	11.17	46.52	100	190	Peak
5150.000	45.12	46.21	54.00	-8.88	34.26	11.17	46.52	100	190	Average
5240.000	102.60	103.58	/	/	34.30	11.27	46.55	100	190	Peak
5240.000	95.51	96.49	/	/	34.30	11.27	46.55	100	190	Average
5350.000	53.27	54.12	74.00	-20.73	34.34	11.39	46.58	100	190	Peak
5350.000	45.68	46.53	54.00	-8.32	34.34	11.39	46.58	100	190	Average

ANTENNA POLARITY & TEST DISTANCE: VERTICAL AT 3 M

FREQ. (MHz)	EMISSION LEVEL (dBuV/m)	READ LEVEL (dBuV)	LIMIT (dBuV/m)	MARGIN (dB)	ANTENNA FACTOR (dB /m)	CABLE LOSS (dB)	PREAMP FACTOR (dB)	ANTENNA HEIGHT (cm)	TABLE ANGLE (Degree)	REMARK
5150.000	52.72	53.65	74.00	-21.28	34.42	11.17	46.52	100	0	Peak
5150.000	45.28	46.21	54.00	-8.72	34.42	11.17	46.52	100	0	Average
5240.000	98.44	99.23	/	/	34.49	11.27	46.55	100	0	Peak
5240.000	90.55	91.34	/	/	34.49	11.27	46.55	100	0	Average
5350.000	52.24	52.85	74.00	-21.76	34.58	11.39	46.58	100	0	Peak
5350.000	45.42	46.03	54.00	-8.58	34.58	11.39	46.58	100	0	Average

REMARKS:

- Emission Level = Read Level+ Antenna Factor + Cable Loss- Preamp Factor
Margin value = Emission level – Limit value.
- 5240MHz: Fundamental frequency.



802.11n (40MHz)

CHANNEL	TX Channel 38	DETECTOR FUNCTION	Peak (PK)
FREQUENCY RANGE	1GHz ~ 40GHz		Average (AV)

ANTENNA POLARITY & TEST DISTANCE: HORIZONTAL AT 3 M										
FREQ. (MHz)	EMISSION LEVEL (dBuV/m)	READ LEVEL (dBuV)	LIMIT (dBuV/m)	MARGIN (dB)	ANTENNA FACTOR (dB /m)	CABLE LOSS (dB)	PREAMP FACTOR (dB)	ANTENNA HEIGHT (cm)	TABLE ANGLE (Degree)	REMARK
5150.000	52.37	53.46	74.00	-21.63	34.26	11.17	46.52	100	190	Peak
5150.000	47.58	48.67	54.00	-6.42	34.26	11.17	46.52	100	190	Average
5190.000	98.21	99.25	/	/	34.28	11.21	46.53	100	190	Peak
5190.000	92.10	93.14	/	/	34.28	11.21	46.53	100	190	Average
5350.000	52.65	53.50	74.00	-21.35	34.34	11.39	46.58	100	190	Peak
5350.000	45.79	46.64	54.00	-8.21	34.34	11.39	46.58	100	190	Average

ANTENNA POLARITY & TEST DISTANCE: VERTICAL AT 3 M										
FREQ. (MHz)	EMISSION LEVEL (dBuV/m)	READ LEVEL (dBuV)	LIMIT (dBuV/m)	MARGIN (dB)	ANTENNA FACTOR (dB /m)	CABLE LOSS (dB)	PREAMP FACTOR (dB)	ANTENNA HEIGHT (cm)	TABLE ANGLE (Degree)	REMARK
5150.000	51.20	52.13	74.00	-22.80	34.42	11.17	46.52	100	315	Peak
5150.000	45.24	46.17	54.00	-8.76	34.42	11.17	46.52	100	315	Average
5190.000	93.90	94.77	/	/	34.45	11.21	46.53	100	315	Peak
5190.000	88.85	89.72	/	/	34.45	11.21	46.53	100	315	Average
5350.000	51.69	52.30	74.00	-22.31	34.58	11.39	46.58	100	315	Peak
5350.000	45.34	45.95	54.00	-8.66	34.58	11.39	46.58	100	315	Average

REMARKS:

- Emission Level = Read Level+ Antenna Factor + Cable Loss- Preamp Factor
Margin value = Emission level – Limit value.
- 5190MHz: Fundamental frequency.



CHANNEL	TX Channel 46	DETECTOR FUNCTION	Peak (PK)
FREQUENCY RANGE	1GHz ~ 40GHz		Average (AV)

ANTENNA POLARITY & TEST DISTANCE: HORIZONTAL AT 3 M										
FREQ. (MHz)	EMISSION LEVEL (dBuV/m)	READ LEVEL (dBuV)	LIMIT (dBuV/m)	MARGIN (dB)	ANTENNA FACTOR (dB /m)	CABLE LOSS (dB)	PREAMP FACTOR (dB)	ANTENNA HEIGHT (cm)	TABLE ANGLE (Degree)	REMARK
5150.000	51.55	52.64	74.00	-22.45	34.26	11.17	46.52	100	190	Peak
5150.000	45.16	46.25	54.00	-8.84	34.26	11.17	46.52	100	190	Average
5230.000	98.59	99.58	/	/	34.29	11.26	46.54	100	190	Peak
5230.000	92.85	93.84	/	/	34.29	11.26	46.54	100	190	Average
5350.000	52.21	53.06	74.00	-21.79	34.34	11.39	46.58	100	190	Peak
5350.000	45.28	46.13	54.00	-8.72	34.34	11.39	46.58	100	190	Average

ANTENNA POLARITY & TEST DISTANCE: VERTICAL AT 3 M										
FREQ. (MHz)	EMISSION LEVEL (dBuV/m)	READ LEVEL (dBuV)	LIMIT (dBuV/m)	MARGIN (dB)	ANTENNA FACTOR (dB /m)	CABLE LOSS (dB)	PREAMP FACTOR (dB)	ANTENNA HEIGHT (cm)	TABLE ANGLE (Degree)	REMARK
5150.000	51.93	52.86	74.00	-22.07	34.42	11.17	46.52	100	315	Peak
5150.000	45.42	46.35	54.00	-8.58	34.42	11.17	46.52	100	315	Average
5230.000	94.22	95.02	/	/	34.48	11.26	46.54	100	315	Peak
5230.000	87.88	88.68	/	/	34.48	11.26	46.54	100	315	Average
5350.000	51.84	52.45	74.00	-22.16	34.58	11.39	46.58	100	315	Peak
5350.000	45.58	46.19	54.00	-8.42	34.58	11.39	46.58	100	315	Average

REMARKS:

- Emission Level = Read Level+ Antenna Factor + Cable Loss- Preamp Factor
Margin value = Emission level – Limit value.
- 5230MHz: Fundamental frequency.



802.11ac (20MHz)

CHANNEL	TX Channel 36	DETECTOR FUNCTION	Peak (PK)
FREQUENCY RANGE	1GHz ~ 40GHz		Average (AV)

ANTENNA POLARITY & TEST DISTANCE: HORIZONTAL AT 3 M										
FREQ. (MHz)	EMISSION LEVEL (dBuV/m)	READ LEVEL (dBuV)	LIMIT (dBuV/m)	MARGIN (dB)	ANTENNA FACTOR (dB /m)	CABLE LOSS (dB)	PREAMP FACTOR (dB)	ANTENNA HEIGHT (cm)	TABLE ANGLE (Degree)	REMARK
5150.000	55.38	56.47	74.00	-18.62	34.26	11.17	46.52	100	190	Peak
5150.000	47.04	48.13	54.00	-6.96	34.26	11.17	46.52	100	190	Average
5180.000	103.29	104.35	/	/	34.27	11.20	46.53	100	190	Peak
5180.000	97.20	98.26	/	/	34.27	11.20	46.53	100	190	Average
5350.000	51.79	52.64	74.00	-22.21	34.34	11.39	46.58	100	190	Peak
5350.000	45.25	46.10	54.00	-8.75	34.34	11.39	46.58	100	190	Average
ANTENNA POLARITY & TEST DISTANCE: VERTICAL AT 3 M										
FREQ. (MHz)	EMISSION LEVEL (dBuV/m)	READ LEVEL (dBuV)	LIMIT (dBuV/m)	MARGIN (dB)	ANTENNA FACTOR (dB /m)	CABLE LOSS (dB)	PREAMP FACTOR (dB)	ANTENNA HEIGHT (cm)	TABLE ANGLE (Degree)	REMARK
5150.000	53.56	54.49	74.00	-20.44	34.42	11.17	46.52	100	315	Peak
5150.000	46.33	47.26	54.00	-7.67	34.42	11.17	46.52	100	315	Average
5180.000	100.84	101.73	/	/	34.44	11.20	46.53	100	315	Peak
5180.000	93.18	94.07	/	/	34.44	11.20	46.53	100	315	Average
5350.000	52.56	53.17	74.00	-21.44	34.58	11.39	46.58	100	315	Peak
5350.000	45.57	46.18	54.00	-8.43	34.58	11.39	46.58	100	315	Average

REMARKS:

- Emission Level = Read Level+ Antenna Factor + Cable Loss- Preamp Factor
Margin value = Emission level – Limit value.
- 5180MHz: Fundamental frequency.



CHANNEL	TX Channel 40	DETECTOR FUNCTION	Peak (PK)
FREQUENCY RANGE	1GHz ~ 40GHz		Average (AV)

ANTENNA POLARITY & TEST DISTANCE: HORIZONTAL AT 3 M										
FREQ. (MHz)	EMISSION LEVEL (dBuV/m)	READ LEVEL (dBuV)	LIMIT (dBuV/m)	MARGIN (dB)	ANTENNA FACTOR (dB /m)	CABLE LOSS (dB)	PREAMP FACTOR (dB)	ANTENNA HEIGHT (cm)	TABLE ANGLE (Degree)	REMARK
5150.000	53.47	54.56	74.00	-20.53	34.26	11.17	46.52	100	190	Peak
5150.000	46.13	47.22	54.00	-7.87	34.26	11.17	46.52	100	190	Average
5200.000	103.21	104.25	/	/	34.28	11.22	46.54	100	190	Peak
5200.000	95.75	96.79	/	/	34.28	11.22	46.54	100	190	Average
5350.000	51.82	52.67	74.00	-22.18	34.34	11.39	46.58	100	190	Peak
5350.000	45.67	46.52	54.00	-8.33	34.34	11.39	46.58	100	190	Average
ANTENNA POLARITY & TEST DISTANCE: VERTICAL AT 3 M										
FREQ. (MHz)	EMISSION LEVEL (dBuV/m)	READ LEVEL (dBuV)	LIMIT (dBuV/m)	MARGIN (dB)	ANTENNA FACTOR (dB /m)	CABLE LOSS (dB)	PREAMP FACTOR (dB)	ANTENNA HEIGHT (cm)	TABLE ANGLE (Degree)	REMARK
5150.000	52.92	53.85	74.00	-21.08	34.42	11.17	46.52	100	315	Peak
5150.000	46.17	47.10	54.00	-7.83	34.42	11.17	46.52	100	315	Average
5200.000	99.86	100.72	/	/	34.46	11.22	46.54	100	315	Peak
5200.000	92.71	93.57	/	/	34.46	11.22	46.54	100	315	Average
5350.000	52.00	52.61	74.00	-22.00	34.58	11.39	46.58	100	315	Peak
5350.000	45.93	46.54	54.00	-8.07	34.58	11.39	46.58	100	315	Average

REMARKS:

1. Emission Level = Read Level+ Antenna Factor + Cable Loss- Preamp Factor
Margin value = Emission level – Limit value.
2. 5200MHz: Fundamental frequency.



CHANNEL	TX Channel 48	DETECTOR FUNCTION	Peak (PK)
FREQUENCY RANGE	1GHz ~ 40GHz		Average (AV)

ANTENNA POLARITY & TEST DISTANCE: HORIZONTAL AT 3 M										
FREQ. (MHz)	EMISSION LEVEL (dBuV/m)	READ LEVEL (dBuV)	LIMIT (dBuV/m)	MARGIN (dB)	ANTENNA FACTOR (dB /m)	CABLE LOSS (dB)	PREAMP FACTOR (dB)	ANTENNA HEIGHT (cm)	TABLE ANGLE (Degree)	REMARK
5150.000	51.58	52.67	74.00	-22.42	34.26	11.17	46.52	100	190	Peak
5150.000	44.87	45.96	54.00	-9.13	34.26	11.17	46.52	100	190	Average
5240.000	102.69	103.67	/	/	34.30	11.27	46.55	100	190	Peak
5240.000	95.40	96.38	/	/	34.30	11.27	46.55	100	190	Average
5350.000	52.82	53.67	74.00	-21.18	34.34	11.39	46.58	100	190	Peak
5350.000	45.39	46.24	54.00	-8.61	34.34	11.39	46.58	100	190	Average

ANTENNA POLARITY & TEST DISTANCE: VERTICAL AT 3 M										
FREQ. (MHz)	EMISSION LEVEL (dBuV/m)	READ LEVEL (dBuV)	LIMIT (dBuV/m)	MARGIN (dB)	ANTENNA FACTOR (dB /m)	CABLE LOSS (dB)	PREAMP FACTOR (dB)	ANTENNA HEIGHT (cm)	TABLE ANGLE (Degree)	REMARK
5150.000	52.33	53.26	74.00	-21.67	34.42	11.17	46.52	100	315	Peak
5150.000	45.32	46.25	54.00	-8.68	34.42	11.17	46.52	100	315	Average
5240.000	99.24	100.03	/	/	34.49	11.27	46.55	100	315	Peak
5240.000	92.31	93.10	/	/	34.49	11.27	46.55	100	315	Average
5350.000	52.04	52.65	74.00	-21.96	34.58	11.39	46.58	100	315	Peak
5350.000	45.54	46.15	54.00	-8.46	34.58	11.39	46.58	100	315	Average

REMARKS:

1. Emission Level = Read Level+ Antenna Factor + Cable Loss- Preamp Factor
Margin value = Emission level – Limit value.
2. 5240MHz: Fundamental frequency.



802.11ac (40MHz)

CHANNEL	TX Channel 38	DETECTOR FUNCTION	Peak (PK)
FREQUENCY RANGE	1GHz ~ 40GHz		Average (AV)

ANTENNA POLARITY & TEST DISTANCE: HORIZONTAL AT 3 M										
FREQ. (MHz)	EMISSION LEVEL (dBuV/m)	READ LEVEL (dBuV)	LIMIT (dBuV/m)	MARGIN (dB)	ANTENNA FACTOR (dB /m)	CABLE LOSS (dB)	PREAMP FACTOR (dB)	ANTENNA HEIGHT (cm)	TABLE ANGLE (Degree)	REMARK
5150.000	53.47	54.56	74.00	-20.53	34.26	11.17	46.52	100	190	Peak
5150.000	47.37	48.46	54.00	-6.63	34.26	11.17	46.52	100	190	Average
5190.000	97.68	98.72	/	/	34.28	11.21	46.53	100	190	Peak
5190.000	91.84	92.88	/	/	34.28	11.21	46.53	100	190	Average
5350.000	51.82	52.67	74.00	-22.18	34.34	11.39	46.58	100	190	Peak
5350.000	45.00	45.85	54.00	-9.00	34.34	11.39	46.58	100	190	Average

ANTENNA POLARITY & TEST DISTANCE: VERTICAL AT 3 M										
FREQ. (MHz)	EMISSION LEVEL (dBuV/m)	READ LEVEL (dBuV)	LIMIT (dBuV/m)	MARGIN (dB)	ANTENNA FACTOR (dB /m)	CABLE LOSS (dB)	PREAMP FACTOR (dB)	ANTENNA HEIGHT (cm)	TABLE ANGLE (Degree)	REMARK
5150.000	51.88	52.81	74.00	-22.12	34.42	11.17	46.52	100	315	Peak
5150.000	45.20	46.13	54.00	-8.80	34.42	11.17	46.52	100	315	Average
5190.000	95.40	96.27	/	/	34.45	11.21	46.53	100	315	Peak
5190.000	90.29	91.16	/	/	34.45	11.21	46.53	100	315	Average
5350.000	52.73	53.34	74.00	-21.27	34.58	11.39	46.58	100	315	Peak
5350.000	46.59	47.20	54.00	-7.41	34.58	11.39	46.58	100	315	Average

REMARKS:

- Emission Level = Read Level+ Antenna Factor + Cable Loss- Preamp Factor
Margin value = Emission level – Limit value.
- 5190MHz: Fundamental frequency.



CHANNEL	TX Channel 46	DETECTOR FUNCTION	Peak (PK)
FREQUENCY RANGE	1GHz ~ 40GHz		Average (AV)

ANTENNA POLARITY & TEST DISTANCE: HORIZONTAL AT 3 M										
FREQ. (MHz)	EMISSION LEVEL (dBuV/m)	READ LEVEL (dBuV)	LIMIT (dBuV/m)	MARGIN (dB)	ANTENNA FACTOR (dB /m)	CABLE LOSS (dB)	PREAMP FACTOR (dB)	ANTENNA HEIGHT (cm)	TABLE ANGLE (Degree)	REMARK
5150.000	52.59	53.68	74.00	-21.41	34.26	11.17	46.52	100	190	Peak
5150.000	45.26	46.35	54.00	-8.74	34.26	11.17	46.52	100	190	Average
5230.000	97.53	98.52	/	/	34.29	11.26	46.54	100	190	Peak
5230.000	91.66	92.65	/	/	34.29	11.26	46.54	100	190	Average
5350.000	50.69	51.54	74.00	-23.31	34.34	11.39	46.58	100	190	Peak
5350.000	45.90	46.75	54.00	-8.10	34.34	11.39	46.58	100	190	Average

ANTENNA POLARITY & TEST DISTANCE: VERTICAL AT 3 M										
FREQ. (MHz)	EMISSION LEVEL (dBuV/m)	READ LEVEL (dBuV)	LIMIT (dBuV/m)	MARGIN (dB)	ANTENNA FACTOR (dB /m)	CABLE LOSS (dB)	PREAMP FACTOR (dB)	ANTENNA HEIGHT (cm)	TABLE ANGLE (Degree)	REMARK
5150.000	51.61	52.54	74.00	-22.39	34.42	11.17	46.52	100	315	Peak
5150.000	46.19	47.12	54.00	-7.81	34.42	11.17	46.52	100	315	Average
5230.000	92.85	93.65	/	/	34.48	11.26	46.54	100	315	Peak
5230.000	88.98	89.78	/	/	34.48	11.26	46.54	100	315	Average
5350.000	51.80	52.41	74.00	-22.20	34.58	11.39	46.58	100	315	Peak
5350.000	45.49	46.10	54.00	-8.51	34.58	11.39	46.58	100	315	Average

REMARKS:

1. Emission Level = Read Level+ Antenna Factor + Cable Loss- Preamp Factor
Margin value = Emission level – Limit value.
2. 5230MHz: Fundamental frequency.



802.11ac (80MHz)

CHANNEL	TX Channel 42	DETECTOR FUNCTION	Peak (PK)
FREQUENCY RANGE	1GHz ~ 40GHz		Average (AV)

ANTENNA POLARITY & TEST DISTANCE: HORIZONTAL AT 3 M										
FREQ. (MHz)	EMISSION LEVEL (dBuV/m)	READ LEVEL (dBuV)	LIMIT (dBuV/m)	MARGIN (dB)	ANTENNA FACTOR (dB / m)	CABLE LOSS (dB)	PREAMP FACTOR (dB)	ANTENNA HEIGHT (cm)	TABLE ANGLE (Degree)	REMARK
5150.000	52.25	53.34	74.00	-21.75	34.26	11.17	46.52	100	190	Peak
5150.000	48.13	49.22	54.00	-5.87	34.26	11.17	46.52	100	190	Average
5210.000	93.51	94.53	/	/	34.28	11.24	46.54	100	190	Peak
5210.000	87.83	88.85	/	/	34.28	11.24	46.54	100	190	Average
5350.000	51.34	52.19	74.00	-22.66	34.34	11.39	46.58	100	190	Peak
5350.000	45.80	46.65	54.00	-8.20	34.34	11.39	46.58	100	190	Average

ANTENNA POLARITY & TEST DISTANCE: VERTICAL AT 3 M										
FREQ. (MHz)	EMISSION LEVEL (dBuV/m)	READ LEVEL (dBuV)	LIMIT (dBuV/m)	MARGIN (dB)	ANTENNA FACTOR (dB / m)	CABLE LOSS (dB)	PREAMP FACTOR (dB)	ANTENNA HEIGHT (cm)	TABLE ANGLE (Degree)	REMARK
5150.000	51.81	52.74	74.00	-22.19	34.42	11.17	46.52	100	315	Peak
5150.000	46.20	47.13	54.00	-7.80	34.42	11.17	46.52	100	315	Average
5210.000	89.50	90.33	/	/	34.47	11.24	46.54	100	315	Peak
5210.000	84.12	84.95	/	/	34.47	11.24	46.54	100	315	Average
5350.000	52.95	53.56	74.00	-21.05	34.58	11.39	46.58	100	315	Peak
5350.000	46.21	46.82	54.00	-7.79	34.58	11.39	46.58	100	315	Average

REMARKS:

- Emission Level = Read Level+ Antenna Factor + Cable Loss- Preamp Factor
Margin value = Emission level – Limit value.
- 5210MHz: Fundamental frequency.



802.11ac (80MHz)

Worst case harmonic:

CHANNEL	TX Channel 42	DETECTOR FUNCTION	Peak (PK)
FREQUENCY RANGE	1GHz ~ 40GHz		Average (AV)

ANTENNA POLARITY & TEST DISTANCE: HORIZONTAL AT 3 M

	Freq	Level	Read Level	Limit Line	Over Limit	Factor	Remark	Pol/Phase
	MHz	dBuV/m	dBuV	dBuV/m	dB	dB/m		
1	10418.000	53.96	45.79	74.00	-20.04	8.17	Peak	Horizontal
2	10418.000	45.08	36.91	54.00	-8.92	8.17	Average	Horizontal
3	PK15630.000	58.65	42.61	74.00	-15.35	16.04	Peak	Horizontal
4	PP15630.000	50.07	34.03	54.00	-3.93	16.04	Average	Horizontal

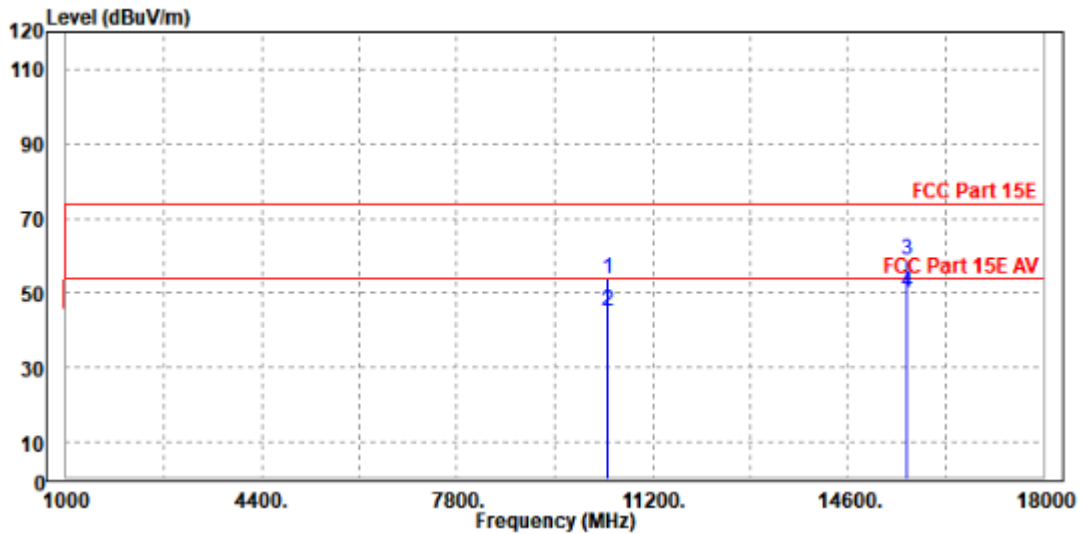



ANTENNA POLARITY & TEST DISTANCE: VERTICAL AT 3 M

	Freq	Level	Read Level	Limit Line	Over Limit	Factor	Remark	Pol/Phase
	MHz	dBuV/m	dBuV	dBuV/m	dB	dB/m		
1	10420.000	52.72	44.36	74.00	-21.28	8.36	Peak	Vertical
2	10420.000	44.52	36.16	54.00	-9.48	8.36	Average	Vertical
3	PK15637.000	58.83	42.54	74.00	-15.17	16.29	Peak	Vertical
4	PP15637.000	49.55	33.26	54.00	-4.45	16.29	Average	Vertical

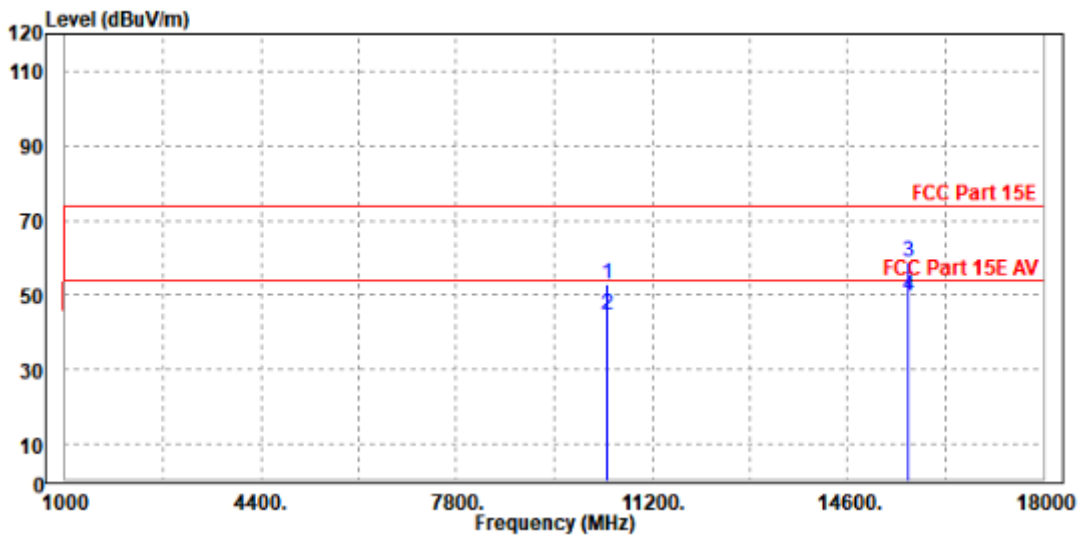

REMARKS:

1. Emission Level = Read Level+ Antenna Factor + Cable Loss- Preamp Factor
Margin value = Emission level – Limit value.
2. 5210MHz: Fundamental frequency.
3. For frequency above 18GHz, the emission was tested 20db below the limit so the data not recorded in the sheet.



Band 2
802.11a

CHANNEL	TX Channel 52	DETECTOR FUNCTION	Peak (PK)
FREQUENCY RANGE	1GHz ~ 40GHz		Average (AV)

ANTENNA POLARITY & TEST DISTANCE: HORIZONTAL AT 3 M

FREQ. (MHz)	EMISSION LEVEL (dBuV/m)	READ LEVEL (dBuV)	LIMIT (dBuV/m)	MARGIN (dB)	ANTENNA FACTOR (dB /m)	CABLE LOSS (dB)	PREAMP FACTOR (dB)	ANTENNA HEIGHT (cm)	TABLE ANGLE (Degree)	REMARK
5150.000	53.56	54.65	74.00	-20.44	34.26	11.17	46.52	100	190	Peak
5150.000	45.48	46.57	54.00	-8.52	34.26	11.17	46.52	100	190	Average
5260.000	103.82	104.78	/	/	34.30	11.29	46.55	100	190	Peak
5260.000	97.36	98.32	/	/	34.30	11.29	46.55	100	190	Average
5350.000	52.56	53.41	74.00	-21.44	34.34	11.39	46.58	100	190	Peak
5350.000	45.01	45.86	54.00	-8.99	34.34	11.39	46.58	100	190	Average

ANTENNA POLARITY & TEST DISTANCE: VERTICAL AT 3 M

FREQ. (MHz)	EMISSION LEVEL (dBuV/m)	READ LEVEL (dBuV)	LIMIT (dBuV/m)	MARGIN (dB)	ANTENNA FACTOR (dB /m)	CABLE LOSS (dB)	PREAMP FACTOR (dB)	ANTENNA HEIGHT (cm)	TABLE ANGLE (Degree)	REMARK
5150.000	53.53	54.46	74.00	-20.47	34.42	11.17	46.52	100	315	Peak
5150.000	45.61	46.54	54.00	-8.39	34.42	11.17	46.52	100	315	Average
5260.000	100.26	101.01	/	/	34.51	11.29	46.55	100	315	Peak
5260.000	92.98	93.73	/	/	34.51	11.29	46.55	100	315	Average
5350.000	52.66	53.27	74.00	-21.34	34.58	11.39	46.58	100	315	Peak
5350.000	45.70	46.31	54.00	-8.30	34.58	11.39	46.58	100	315	Average

REMARKS:

- Emission Level = Read Level+ Antenna Factor + Cable Loss- Preamp Factor
Margin value = Emission level – Limit value.
- 5260MHz: Fundamental frequency.



CHANNEL	TX Channel 60	DETECTOR FUNCTION	Peak (PK)
FREQUENCY RANGE	1GHz ~ 40GHz		Average (AV)

ANTENNA POLARITY & TEST DISTANCE: HORIZONTAL AT 3 M

FREQ. (MHz)	EMISSION LEVEL (dBuV/m)	READ LEVEL (dBuV)	LIMIT (dBuV/m)	MARGIN (dB)	ANTENNA FACTOR (dB /m)	CABLE LOSS (dB)	PREAMP FACTOR (dB)	ANTENNA HEIGHT (cm)	TABLE ANGLE (Degree)	REMARK
5150.000	52.17	53.26	74.00	-21.83	34.26	11.17	46.52	100	190	Peak
5150.000	45.23	46.32	54.00	-8.77	34.26	11.17	46.52	100	190	Average
5300.000	104.30	105.20	/	/	34.32	11.34	46.56	100	190	Peak
5300.000	97.74	98.64	/	/	34.32	11.34	46.56	100	190	Average
5350.000	51.41	52.26	74.00	-22.59	34.34	11.39	46.58	100	190	Peak
5350.000	45.45	46.30	54.00	-8.55	34.34	11.39	46.58	100	190	Average

ANTENNA POLARITY & TEST DISTANCE: VERTICAL AT 3 M

FREQ. (MHz)	EMISSION LEVEL (dBuV/m)	READ LEVEL (dBuV)	LIMIT (dBuV/m)	MARGIN (dB)	ANTENNA FACTOR (dB /m)	CABLE LOSS (dB)	PREAMP FACTOR (dB)	ANTENNA HEIGHT (cm)	TABLE ANGLE (Degree)	REMARK
5150.000	51.92	52.85	74.00	-22.08	34.42	11.17	46.52	100	315	Peak
5150.000	45.42	46.35	54.00	-8.58	34.42	11.17	46.52	100	315	Average
5300.000	99.66	100.34	/	/	34.54	11.34	46.56	100	315	Peak
5300.000	93.02	93.70	/	/	34.54	11.34	46.56	100	315	Average
5350.000	53.03	53.64	74.00	-20.97	34.58	11.39	46.58	100	315	Peak
5350.000	45.25	45.86	54.00	-8.75	34.58	11.39	46.58	100	315	Average

REMARKS:

- Emission Level = Read Level+ Antenna Factor + Cable Loss- Preamp Factor
Margin value = Emission level – Limit value.
- 5300MHz: Fundamental frequency.



CHANNEL	TX Channel 64	DETECTOR FUNCTION	Peak (PK)
FREQUENCY RANGE	1GHz ~ 40GHz		Average (AV)

ANTENNA POLARITY & TEST DISTANCE: HORIZONTAL AT 3 M

FREQ. (MHz)	EMISSION LEVEL (dBuV/m)	READ LEVEL (dBuV)	LIMIT (dBuV/m)	MARGIN (dB)	ANTENNA FACTOR (dB /m)	CABLE LOSS (dB)	PREAMP FACTOR (dB)	ANTENNA HEIGHT (cm)	TABLE ANGLE (Degree)	REMARK
5150.000	52.43	53.52	74.00	-21.57	34.26	11.17	46.52	100	190	Peak
5150.000	45.26	46.35	54.00	-8.74	34.26	11.17	46.52	100	190	Average
5320.000	103.48	104.36	/	/	34.33	11.36	46.57	100	190	Peak
5320.000	96.66	97.54	/	/	34.33	11.36	46.57	100	190	Average
5350.000	51.96	52.81	74.00	-22.04	34.34	11.39	46.58	100	190	Peak
5350.000	45.86	46.71	54.00	-8.14	34.34	11.39	46.58	100	190	Average

ANTENNA POLARITY & TEST DISTANCE: VERTICAL AT 3 M

FREQ. (MHz)	EMISSION LEVEL (dBuV/m)	READ LEVEL (dBuV)	LIMIT (dBuV/m)	MARGIN (dB)	ANTENNA FACTOR (dB /m)	CABLE LOSS (dB)	PREAMP FACTOR (dB)	ANTENNA HEIGHT (cm)	TABLE ANGLE (Degree)	REMARK
5150.000	51.68	52.61	74.00	-22.32	34.42	11.17	46.52	100	0	Peak
5150.000	45.35	46.28	54.00	-8.65	34.42	11.17	46.52	100	0	Average
5320.000	99.25	99.90	/	/	34.56	11.36	46.57	100	0	Peak
5320.000	92.95	93.60	/	/	34.56	11.36	46.57	100	0	Average
5350.000	52.66	53.27	74.00	-21.34	34.58	11.39	46.58	100	0	Peak
5350.000	45.92	46.53	54.00	-8.08	34.58	11.39	46.58	100	0	Average

REMARKS:

- Emission Level = Read Level+ Antenna Factor + Cable Loss- Preamp Factor
Margin value = Emission level – Limit value.
- 5320MHz: Fundamental frequency.



802.11n (20MHz)

CHANNEL	TX Channel 52	DETECTOR FUNCTION	Peak (PK)
FREQUENCY RANGE	1GHz ~ 40GHz		Average (AV)

ANTENNA POLARITY & TEST DISTANCE: HORIZONTAL AT 3 M

FREQ. (MHz)	EMISSION LEVEL (dBuV/m)	READ LEVEL (dBuV)	LIMIT (dBuV/m)	MARGIN (dB)	ANTENNA FACTOR (dB /m)	CABLE LOSS (dB)	PREAMP FACTOR (dB)	ANTENNA HEIGHT (cm)	TABLE ANGLE (Degree)	REMARK
5150.000	53.14	54.23	74.00	-20.86	34.26	11.17	46.52	100	190	Peak
5150.000	46.16	47.25	54.00	-7.84	34.26	11.17	46.52	100	190	Average
5260.000	102.60	103.56	/	/	34.30	11.29	46.55	100	190	Peak
5260.000	95.11	96.07	/	/	34.30	11.29	46.55	100	190	Average
5350.000	52.47	53.32	74.00	-21.53	34.34	11.39	46.58	100	190	Peak
5350.000	45.28	46.13	54.00	-8.72	34.34	11.39	46.58	100	190	Average

ANTENNA POLARITY & TEST DISTANCE: VERTICAL AT 3 M

FREQ. (MHz)	EMISSION LEVEL (dBuV/m)	READ LEVEL (dBuV)	LIMIT (dBuV/m)	MARGIN (dB)	ANTENNA FACTOR (dB /m)	CABLE LOSS (dB)	PREAMP FACTOR (dB)	ANTENNA HEIGHT (cm)	TABLE ANGLE (Degree)	REMARK
5150.000	53.29	54.22	74.00	-20.71	34.42	11.17	46.52	100	315	Peak
5150.000	45.45	46.38	54.00	-8.55	34.42	11.17	46.52	100	315	Average
5260.000	99.50	100.25	/	/	34.51	11.29	46.55	100	315	Peak
5260.000	91.60	92.35	/	/	34.51	11.29	46.55	100	315	Average
5350.000	52.24	52.85	74.00	-21.76	34.58	11.39	46.58	100	315	Peak
5350.000	45.66	46.27	54.00	-8.34	34.58	11.39	46.58	100	315	Average

REMARKS:

- Emission Level = Read Level+ Antenna Factor + Cable Loss- Preamp Factor
Margin value = Emission level – Limit value.
- 5260MHz: Fundamental frequency.



CHANNEL	TX Channel 60	DETECTOR FUNCTION	Peak (PK)
FREQUENCY RANGE	1GHz ~ 40GHz		Average (AV)

ANTENNA POLARITY & TEST DISTANCE: HORIZONTAL AT 3 M

FREQ. (MHz)	EMISSION LEVEL (dBuV/m)	READ LEVEL (dBuV)	LIMIT (dBuV/m)	MARGIN (dB)	ANTENNA FACTOR (dB /m)	CABLE LOSS (dB)	PREAMP FACTOR (dB)	ANTENNA HEIGHT (cm)	TABLE ANGLE (Degree)	REMARK
5150.000	51.78	52.87	74.00	-22.22	34.26	11.17	46.52	100	190	Peak
5150.000	46.27	47.36	54.00	-7.73	34.26	11.17	46.52	100	190	Average
5300.000	102.33	103.23	/	/	34.32	11.34	46.56	100	190	Peak
5300.000	95.15	96.05	/	/	34.32	11.34	46.56	100	190	Average
5350.000	53.87	54.72	74.00	-20.13	34.34	11.39	46.58	100	190	Peak
5350.000	46.00	46.85	54.00	-8.00	34.34	11.39	46.58	100	190	Average

ANTENNA POLARITY & TEST DISTANCE: VERTICAL AT 3 M

FREQ. (MHz)	EMISSION LEVEL (dBuV/m)	READ LEVEL (dBuV)	LIMIT (dBuV/m)	MARGIN (dB)	ANTENNA FACTOR (dB /m)	CABLE LOSS (dB)	PREAMP FACTOR (dB)	ANTENNA HEIGHT (cm)	TABLE ANGLE (Degree)	REMARK
5150.000	52.69	53.62	74.00	-21.31	34.42	11.17	46.52	100	315	Peak
5150.000	45.20	46.13	54.00	-8.80	34.42	11.17	46.52	100	315	Average
5300.000	99.16	99.84	/	/	34.54	11.34	46.56	100	315	Peak
5300.000	92.47	93.15	/	/	34.54	11.34	46.56	100	315	Average
5350.000	52.04	52.65	74.00	-21.96	34.58	11.39	46.58	100	315	Peak
5350.000	46.63	47.24	54.00	-7.37	34.58	11.39	46.58	100	315	Average

REMARKS:

- Emission Level = Read Level+ Antenna Factor + Cable Loss- Preamp Factor
Margin value = Emission level – Limit value.
- 5300MHz: Fundamental frequency.



CHANNEL	TX Channel 64	DETECTOR FUNCTION	Peak (PK)
FREQUENCY RANGE	1GHz ~ 40GHz		Average (AV)

ANTENNA POLARITY & TEST DISTANCE: HORIZONTAL AT 3 M										
FREQ. (MHz)	EMISSION LEVEL (dBuV/m)	READ LEVEL (dBuV)	LIMIT (dBuV/m)	MARGIN (dB)	ANTENNA FACTOR (dB /m)	CABLE LOSS (dB)	PREAMP FACTOR (dB)	ANTENNA HEIGHT (cm)	TABLE ANGLE (Degree)	REMARK
5150.000	51.52	52.61	74.00	-22.48	34.26	11.17	46.52	100	190	Peak
5150.000	45.48	46.57	54.00	-8.52	34.26	11.17	46.52	100	190	Average
5320.000	101.64	102.52	/	/	34.33	11.36	46.57	100	190	Peak
5320.000	94.49	95.37	/	/	34.33	11.36	46.57	100	190	Average
5350.000	53.31	54.16	74.00	-20.69	34.34	11.39	46.58	100	190	Peak
5350.000	46.51	47.36	54.00	-7.49	34.34	11.39	46.58	100	190	Average

ANTENNA POLARITY & TEST DISTANCE: VERTICAL AT 3 M										
FREQ. (MHz)	EMISSION LEVEL (dBuV/m)	READ LEVEL (dBuV)	LIMIT (dBuV/m)	MARGIN (dB)	ANTENNA FACTOR (dB /m)	CABLE LOSS (dB)	PREAMP FACTOR (dB)	ANTENNA HEIGHT (cm)	TABLE ANGLE (Degree)	REMARK
5150.000	51.72	52.65	74.00	-22.28	34.42	11.17	46.52	100	315	Peak
5150.000	45.30	46.23	54.00	-8.70	34.42	11.17	46.52	100	315	Average
5320.000	97.99	98.64	/	/	34.56	11.36	46.57	100	315	Peak
5320.000	91.09	91.74	/	/	34.56	11.36	46.57	100	315	Average
5350.000	52.57	53.18	74.00	-21.43	34.58	11.39	46.58	100	315	Peak
5350.000	45.84	46.45	54.00	-8.16	34.58	11.39	46.58	100	315	Average

REMARKS:

1. Emission Level = Read Level+ Antenna Factor + Cable Loss- Preamp Factor
Margin value = Emission level – Limit value.
2. 5320MHz: Fundamental frequency.



802.11n (40MHz)

CHANNEL	TX Channel 54	DETECTOR FUNCTION	Peak (PK)
FREQUENCY RANGE	1GHz ~ 40GHz		Average (AV)

ANTENNA POLARITY & TEST DISTANCE: HORIZONTAL AT 3 M										
FREQ. (MHz)	EMISSION LEVEL (dBuV/m)	READ LEVEL (dBuV)	LIMIT (dBuV/m)	MARGIN (dB)	ANTENNA FACTOR (dB /m)	CABLE LOSS (dB)	PREAMP FACTOR (dB)	ANTENNA HEIGHT (cm)	TABLE ANGLE (Degree)	REMARK
5150.000	52.17	53.26	74.00	-21.83	34.26	11.17	46.52	100	190	Peak
5150.000	45.50	46.59	54.00	-8.50	34.26	11.17	46.52	100	190	Average
5270.000	95.50	96.45	/	/	34.31	11.30	46.56	100	190	Peak
5270.000	90.41	91.36	/	/	34.31	11.30	46.56	100	190	Average
5350.000	51.64	52.49	74.00	-22.36	34.34	11.39	46.58	100	190	Peak
5350.000	45.47	46.32	54.00	-8.53	34.34	11.39	46.58	100	190	Average

ANTENNA POLARITY & TEST DISTANCE: VERTICAL AT 3 M										
FREQ. (MHz)	EMISSION LEVEL (dBuV/m)	READ LEVEL (dBuV)	LIMIT (dBuV/m)	MARGIN (dB)	ANTENNA FACTOR (dB /m)	CABLE LOSS (dB)	PREAMP FACTOR (dB)	ANTENNA HEIGHT (cm)	TABLE ANGLE (Degree)	REMARK
5150.000	51.43	52.36	74.00	-22.57	34.42	11.17	46.52	100	315	Peak
5150.000	45.46	46.39	54.00	-8.54	34.42	11.17	46.52	100	315	Average
5270.000	92.29	93.03	/	/	34.52	11.30	46.56	100	315	Peak
5270.000	87.22	87.96	/	/	34.52	11.30	46.56	100	315	Average
5350.000	51.25	51.86	74.00	-22.75	34.58	11.39	46.58	100	315	Peak
5350.000	45.06	45.67	54.00	-8.94	34.58	11.39	46.58	100	315	Average

REMARKS:

- Emission Level = Read Level+ Antenna Factor + Cable Loss- Preamp Factor
Margin value = Emission level – Limit value.
- 5270MHz: Fundamental frequency.



CHANNEL	TX Channel 62	DETECTOR FUNCTION	Peak (PK)
FREQUENCY RANGE	1GHz ~ 40GHz		Average (AV)

ANTENNA POLARITY & TEST DISTANCE: HORIZONTAL AT 3 M										
FREQ. (MHz)	EMISSION LEVEL (dBuV/m)	READ LEVEL (dBuV)	LIMIT (dBuV/m)	MARGIN (dB)	ANTENNA FACTOR (dB /m)	CABLE LOSS (dB)	PREAMP FACTOR (dB)	ANTENNA HEIGHT (cm)	TABLE ANGLE (Degree)	REMARK
5150.000	51.10	52.19	74.00	-22.90	34.26	11.17	46.52	100	190	Peak
5150.000	45.12	46.21	54.00	-8.88	34.26	11.17	46.52	100	190	Average
5310.000	97.62	98.52	/	/	34.32	11.35	46.57	100	190	Peak
5310.000	91.63	92.53	/	/	34.32	11.35	46.57	100	190	Average
5350.000	54.78	55.63	74.00	-19.22	34.34	11.39	46.58	100	190	Peak
5350.000	48.22	49.07	54.00	-5.78	34.34	11.39	46.58	100	190	Average

ANTENNA POLARITY & TEST DISTANCE: VERTICAL AT 3 M										
FREQ. (MHz)	EMISSION LEVEL (dBuV/m)	READ LEVEL (dBuV)	LIMIT (dBuV/m)	MARGIN (dB)	ANTENNA FACTOR (dB /m)	CABLE LOSS (dB)	PREAMP FACTOR (dB)	ANTENNA HEIGHT (cm)	TABLE ANGLE (Degree)	REMARK
5150.000	51.92	52.85	74.00	-22.08	34.42	11.17	46.52	100	315	Peak
5150.000	44.93	45.86	54.00	-9.07	34.42	11.17	46.52	100	315	Average
5310.000	91.96	92.63	/	/	34.55	11.35	46.57	100	315	Peak
5310.000	92.39	93.06	/	/	34.55	11.35	46.57	100	315	Average
5350.000	53.00	53.61	74.00	-21.00	34.58	11.39	46.58	100	315	Peak
5350.000	47.02	47.63	54.00	-6.98	34.58	11.39	46.58	100	315	Average

REMARKS:

1. Emission Level = Read Level+ Antenna Factor + Cable Loss- Preamp Factor
Margin value = Emission level – Limit value.
2. 5310MHz: Fundamental frequency.



802.11ac (20MHz)

CHANNEL	TX Channel 52	DETECTOR FUNCTION	Peak (PK)
FREQUENCY RANGE	1GHz ~ 40GHz		Average (AV)

ANTENNA POLARITY & TEST DISTANCE: HORIZONTAL AT 3 M										
FREQ. (MHz)	EMISSION LEVEL (dBuV/m)	READ LEVEL (dBuV)	LIMIT (dBuV/m)	MARGIN (dB)	ANTENNA FACTOR (dB /m)	CABLE LOSS (dB)	PREAMP FACTOR (dB)	ANTENNA HEIGHT (cm)	TABLE ANGLE (Degree)	REMARK
5150.000	52.39	53.48	74.00	-21.61	34.26	11.17	46.52	100	190	Peak
5150.000	45.48	46.57	54.00	-8.52	34.26	11.17	46.52	100	190	Average
5260.000	101.89	102.85	/	/	34.30	11.29	46.55	100	190	Peak
5260.000	94.90	95.86	/	/	34.30	11.29	46.55	100	190	Average
5350.000	53.90	54.75	74.00	-20.10	34.34	11.39	46.58	100	190	Peak
5350.000	45.64	46.49	54.00	-8.36	34.34	11.39	46.58	100	190	Average

ANTENNA POLARITY & TEST DISTANCE: VERTICAL AT 3 M										
FREQ. (MHz)	EMISSION LEVEL (dBuV/m)	READ LEVEL (dBuV)	LIMIT (dBuV/m)	MARGIN (dB)	ANTENNA FACTOR (dB /m)	CABLE LOSS (dB)	PREAMP FACTOR (dB)	ANTENNA HEIGHT (cm)	TABLE ANGLE (Degree)	REMARK
5150.000	51.58	52.51	74.00	-22.42	34.42	11.17	46.52	100	315	Peak
5150.000	45.42	46.35	54.00	-8.58	34.42	11.17	46.52	100	315	Average
5260.000	99.46	100.21	/	/	34.51	11.29	46.55	100	315	Peak
5260.000	93.90	94.65	/	/	34.51	11.29	46.55	100	315	Average
5350.000	51.04	51.65	74.00	-22.96	34.58	11.39	46.58	100	315	Peak
5350.000	45.14	45.75	54.00	-8.86	34.58	11.39	46.58	100	315	Average

REMARKS:

- Emission Level = Read Level+ Antenna Factor + Cable Loss- Preamp Factor
Margin value = Emission level – Limit value.
- 5260MHz: Fundamental frequency.



CHANNEL	TX Channel 60	DETECTOR FUNCTION	Peak (PK)
FREQUENCY RANGE	1GHz ~ 40GHz		Average (AV)

ANTENNA POLARITY & TEST DISTANCE: HORIZONTAL AT 3 M										
FREQ. (MHz)	EMISSION LEVEL (dBuV/m)	READ LEVEL (dBuV)	LIMIT (dBuV/m)	MARGIN (dB)	ANTENNA FACTOR (dB /m)	CABLE LOSS (dB)	PREAMP FACTOR (dB)	ANTENNA HEIGHT (cm)	TABLE ANGLE (Degree)	REMARK
5150.000	52.52	53.61	74.00	-21.48	34.26	11.17	46.52	100	190	Peak
5150.000	45.85	46.94	54.00	-8.15	34.26	11.17	46.52	100	190	Average
5300.000	102.36	103.26	/	/	34.32	11.34	46.56	100	190	Peak
5300.000	95.74	96.64	/	/	34.32	11.34	46.56	100	190	Average
5350.000	52.31	53.16	74.00	-21.69	34.34	11.39	46.58	100	190	Peak
5350.000	45.69	46.54	54.00	-8.31	34.34	11.39	46.58	100	190	Average

ANTENNA POLARITY & TEST DISTANCE: VERTICAL AT 3 M										
FREQ. (MHz)	EMISSION LEVEL (dBuV/m)	READ LEVEL (dBuV)	LIMIT (dBuV/m)	MARGIN (dB)	ANTENNA FACTOR (dB /m)	CABLE LOSS (dB)	PREAMP FACTOR (dB)	ANTENNA HEIGHT (cm)	TABLE ANGLE (Degree)	REMARK
5150.000	52.33	53.26	74.00	-21.67	34.42	11.17	46.52	100	190	Peak
5150.000	45.52	46.45	54.00	-8.48	34.42	11.17	46.52	100	190	Average
5300.000	100.27	100.95	/	/	34.54	11.34	46.56	100	190	Peak
5300.000	94.47	95.15	/	/	34.54	11.34	46.56	100	190	Average
5350.000	51.55	52.16	74.00	-22.45	34.58	11.39	46.58	100	190	Peak
5350.000	45.42	46.03	54.00	-8.58	34.58	11.39	46.58	100	190	Average

REMARKS:

1. Emission Level = Read Level+ Antenna Factor + Cable Loss- Preamp Factor
Margin value = Emission level – Limit value.
2. 5300MHz: Fundamental frequency.



CHANNEL	TX Channel 64	DETECTOR FUNCTION	Peak (PK)
FREQUENCY RANGE	1GHz ~ 40GHz		Average (AV)

ANTENNA POLARITY & TEST DISTANCE: HORIZONTAL AT 3 M										
FREQ. (MHz)	EMISSION LEVEL (dBuV/m)	READ LEVEL (dBuV)	LIMIT (dBuV/m)	MARGIN (dB)	ANTENNA FACTOR (dB /m)	CABLE LOSS (dB)	PREAMP FACTOR (dB)	ANTENNA HEIGHT (cm)	TABLE ANGLE (Degree)	REMARK
5150.000	52.03	53.12	74.00	-21.97	34.26	11.17	46.52	100	190	Peak
5150.000	44.94	46.03	54.00	-9.06	34.26	11.17	46.52	100	190	Average
5320.000	101.44	102.32	/	/	34.33	11.36	46.57	100	190	Peak
5320.000	95.08	95.96	/	/	34.33	11.36	46.57	100	190	Average
5350.000	54.00	54.85	74.00	-20.00	34.34	11.39	46.58	100	190	Peak
5350.000	46.41	47.26	54.00	-7.59	34.34	11.39	46.58	100	190	Average

ANTENNA POLARITY & TEST DISTANCE: VERTICAL AT 3 M										
FREQ. (MHz)	EMISSION LEVEL (dBuV/m)	READ LEVEL (dBuV)	LIMIT (dBuV/m)	MARGIN (dB)	ANTENNA FACTOR (dB /m)	CABLE LOSS (dB)	PREAMP FACTOR (dB)	ANTENNA HEIGHT (cm)	TABLE ANGLE (Degree)	REMARK
5150.000	52.69	53.62	74.00	-21.31	34.42	11.17	46.52	100	190	Peak
5150.000	45.39	46.32	54.00	-8.61	34.42	11.17	46.52	100	190	Average
5320.000	98.79	99.44	/	/	34.56	11.36	46.57	100	190	Peak
5320.000	92.42	93.07	/	/	34.56	11.36	46.57	100	190	Average
5350.000	53.06	53.67	74.00	-20.94	34.58	11.39	46.58	100	190	Peak
5350.000	46.34	46.95	54.00	-7.66	34.58	11.39	46.58	100	190	Average

REMARKS:

1. Emission Level = Read Level+ Antenna Factor + Cable Loss- Preamp Factor
Margin value = Emission level – Limit value.
2. 5320MHz: Fundamental frequency.



802.11ac (40MHz)

CHANNEL	TX Channel 54	DETECTOR FUNCTION	Peak (PK)
FREQUENCY RANGE	1GHz ~ 40GHz		Average (AV)

ANTENNA POLARITY & TEST DISTANCE: HORIZONTAL AT 3 M										
FREQ. (MHz)	EMISSION LEVEL (dBuV/m)	READ LEVEL (dBuV)	LIMIT (dBuV/m)	MARGIN (dB)	ANTENNA FACTOR (dB /m)	CABLE LOSS (dB)	PREAMP FACTOR (dB)	ANTENNA HEIGHT (cm)	TABLE ANGLE (Degree)	REMARK
5150.000	51.60	52.69	74.00	-22.40	34.26	11.17	46.52	100	190	Peak
5150.000	45.63	46.72	54.00	-8.37	34.26	11.17	46.52	100	190	Average
5270.000	96.80	97.75	/	/	34.31	11.30	46.56	100	190	Peak
5270.000	90.99	91.94	/	/	34.31	11.30	46.56	100	190	Average
5350.000	51.48	52.33	74.00	-22.52	34.34	11.39	46.58	100	190	Peak
5350.000	45.38	46.23	54.00	-8.62	34.34	11.39	46.58	100	190	Average

ANTENNA POLARITY & TEST DISTANCE: VERTICAL AT 3 M										
FREQ. (MHz)	EMISSION LEVEL (dBuV/m)	READ LEVEL (dBuV)	LIMIT (dBuV/m)	MARGIN (dB)	ANTENNA FACTOR (dB /m)	CABLE LOSS (dB)	PREAMP FACTOR (dB)	ANTENNA HEIGHT (cm)	TABLE ANGLE (Degree)	REMARK
5150.000	52.32	53.25	74.00	-21.68	34.42	11.17	46.52	100	315	Peak
5150.000	45.62	46.55	54.00	-8.38	34.42	11.17	46.52	100	315	Average
5270.000	92.19	92.93	/	/	34.52	11.30	46.56	100	315	Peak
5270.000	87.41	88.15	/	/	34.52	11.30	46.56	100	315	Average
5350.000	52.04	52.65	74.00	-21.96	34.58	11.39	46.58	100	315	Peak
5350.000	45.92	46.53	54.00	-8.08	34.58	11.39	46.58	100	315	Average

REMARKS:

- Emission Level = Read Level+ Antenna Factor + Cable Loss- Preamp Factor
Margin value = Emission level – Limit value.
- 5270MHz: Fundamental frequency.



CHANNEL	TX Channel 62	DETECTOR FUNCTION	Peak (PK)
FREQUENCY RANGE	1GHz ~ 40GHz		Average (AV)

ANTENNA POLARITY & TEST DISTANCE: HORIZONTAL AT 3 M

FREQ. (MHz)	EMISSION LEVEL (dBuV/m)	READ LEVEL (dBuV)	LIMIT (dBuV/m)	MARGIN (dB)	ANTENNA FACTOR (dB /m)	CABLE LOSS (dB)	PREAMP FACTOR (dB)	ANTENNA HEIGHT (cm)	TABLE ANGLE (Degree)	REMARK
5150.000	51.56	52.65	74.00	-22.44	34.26	11.17	46.52	100	190	Peak
5150.000	45.14	46.23	54.00	-8.86	34.26	11.17	46.52	100	190	Average
5310.000	96.61	97.51	/	/	34.32	11.35	46.57	100	190	Peak
5310.000	91.25	92.15	/	/	34.32	11.35	46.57	100	190	Average
5350.000	52.86	53.71	74.00	-21.14	34.34	11.39	46.58	100	190	Peak
5350.000	47.57	48.42	54.00	-6.43	34.34	11.39	46.58	100	190	Average

ANTENNA POLARITY & TEST DISTANCE: VERTICAL AT 3 M

FREQ. (MHz)	EMISSION LEVEL (dBuV/m)	READ LEVEL (dBuV)	LIMIT (dBuV/m)	MARGIN (dB)	ANTENNA FACTOR (dB /m)	CABLE LOSS (dB)	PREAMP FACTOR (dB)	ANTENNA HEIGHT (cm)	TABLE ANGLE (Degree)	REMARK
5150.000	51.56	52.49	74.00	-22.44	34.42	11.17	46.52	100	315	Peak
5150.000	45.30	46.23	54.00	-8.70	34.42	11.17	46.52	100	315	Average
5310.000	92.97	93.64	/	/	34.55	11.35	46.57	100	315	Peak
5310.000	87.41	88.08	/	/	34.55	11.35	46.57	100	315	Average
5350.000	53.03	53.64	74.00	-20.97	34.58	11.39	46.58	100	315	Peak
5350.000	46.14	46.75	54.00	-7.86	34.58	11.39	46.58	100	315	Average

REMARKS:

- Emission Level = Read Level+ Antenna Factor + Cable Loss- Preamp Factor
Margin value = Emission level – Limit value.
- 5310MHz: Fundamental frequency.



802.11ac (80MHz)

CHANNEL	TX Channel 58	DETECTOR FUNCTION	Peak (PK)
FREQUENCY RANGE	1GHz ~ 40GHz		Average (AV)

ANTENNA POLARITY & TEST DISTANCE: HORIZONTAL AT 3 M										
FREQ. (MHz)	EMISSION LEVEL (dBuV/m)	READ LEVEL (dBuV)	LIMIT (dBuV/m)	MARGIN (dB)	ANTENNA FACTOR (dB /m)	CABLE LOSS (dB)	PREAMP FACTOR (dB)	ANTENNA HEIGHT (cm)	TABLE ANGLE (Degree)	REMARK
5150.000	52.36	53.45	74.00	-21.64	34.26	11.17	46.52	100	190	Peak
5150.000	46.27	47.36	54.00	-7.73	34.26	11.17	46.52	100	190	Average
5290.000	91.92	92.84	/	/	34.32	11.32	46.56	100	190	Peak
5290.000	87.73	88.65	/	/	34.32	11.32	46.56	100	190	Average
5350.000	54.92	55.77	74.00	-19.08	34.34	11.39	46.58	100	190	Peak
5350.000	48.67	49.52	54.00	-5.33	34.34	11.39	46.58	100	190	Average

ANTENNA POLARITY & TEST DISTANCE: VERTICAL AT 3 M										
FREQ. (MHz)	EMISSION LEVEL (dBuV/m)	READ LEVEL (dBuV)	LIMIT (dBuV/m)	MARGIN (dB)	ANTENNA FACTOR (dB /m)	CABLE LOSS (dB)	PREAMP FACTOR (dB)	ANTENNA HEIGHT (cm)	TABLE ANGLE (Degree)	REMARK
5150.000	52.26	53.19	74.00	-21.74	34.42	11.17	46.52	100	315	Peak
5150.000	45.31	46.24	54.00	-8.69	34.42	11.17	46.52	100	315	Average
5290.000	88.84	89.55	/	/	34.53	11.32	46.56	100	315	Peak
5290.000	82.91	83.62	/	/	34.53	11.32	46.56	100	315	Average
5350.000	53.88	54.49	74.00	-20.12	34.58	11.39	46.58	100	315	Peak
5350.000	46.52	47.13	54.00	-7.48	34.58	11.39	46.58	100	315	Average

REMARKS:

- Emission Level = Read Level+ Antenna Factor + Cable Loss- Preamp Factor
Margin value = Emission level – Limit value.
- 5290MHz: Fundamental frequency.



802.11ac (80MHz)

Worst case harmonic:

CHANNEL	TX Channel 58	DETECTOR FUNCTION	Peak (PK)
FREQUENCY RANGE	1GHz ~ 40GHz		Average (AV)

ANTENNA POLARITY & TEST DISTANCE: HORIZONTAL AT 3 M

	Freq	Level	Read Level	Limit Line	Over Limit	Factor	Remark	Pol/Phase
	MHz	dBuV/m	dBuV	dBuV/m	dB	dB/m		
1	10580.000	53.63	45.43	74.00	-20.37	8.20	Peak	Horizontal
2	10580.000	44.69	36.49	54.00	-9.31	8.20	Average	Horizontal
3	PK15875.000	58.30	42.03	74.00	-15.70	16.27	Peak	Horizontal
4	PP15875.000	48.43	32.16	54.00	-5.57	16.27	Average	Horizontal

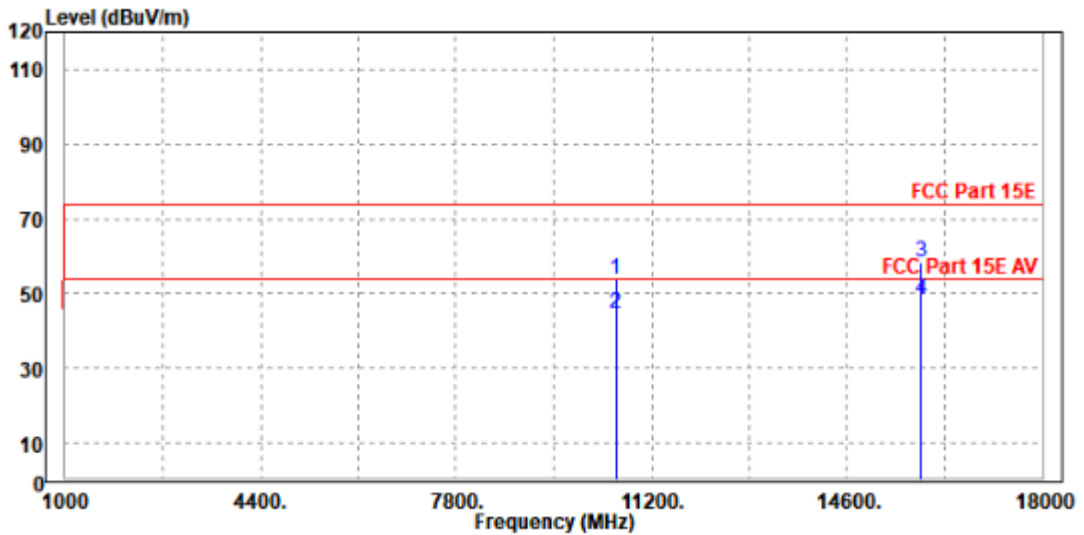



ANTENNA POLARITY & TEST DISTANCE: VERTICAL AT 3 M

	Freq	Level	Read Level	Limit Line	Over Limit	Factor	Remark	Pol/Phase
	MHz	dBuV/m	dBuV	dBuV/m	dB	dB/m		
1	10588.000	54.59	46.19	74.00	-19.41	8.40	Peak	Vertical
2	10588.000	45.18	36.78	54.00	-8.82	8.40	Average	Vertical
3	PK15870.000	59.53	42.79	74.00	-14.47	16.74	Peak	Vertical
4	PP15870.000	49.26	32.52	54.00	-4.74	16.74	Average	Vertical

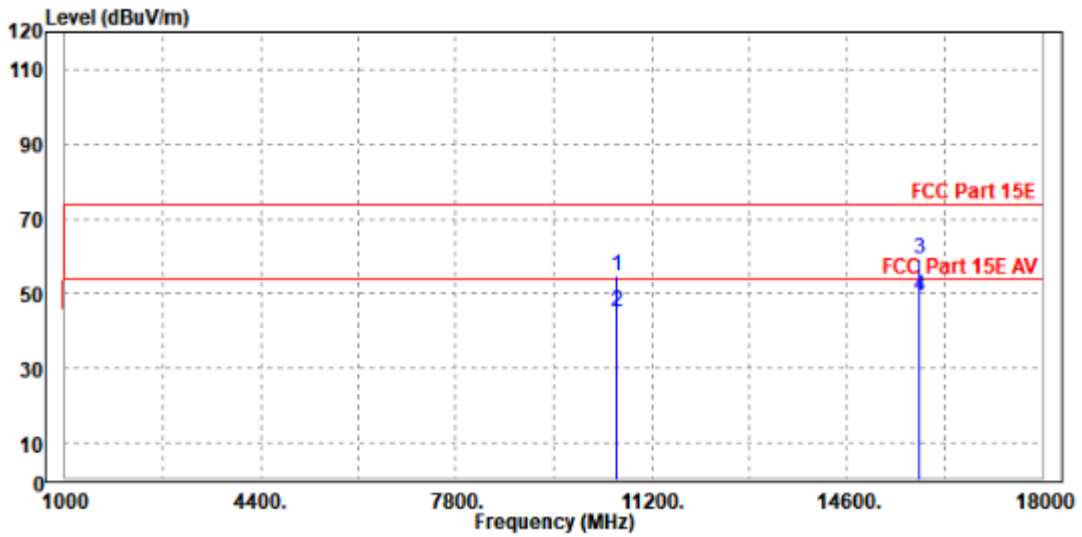

REMARKS:

1. Emission Level = Read Level+ Antenna Factor + Cable Loss- Preamp Factor
Margin value = Emission level – Limit value.
2. 5290MHz: Fundamental frequency.
3. For frequency above 18GHz, the emission was tested 20db below the limit so the data not recorded in the sheet.



Band 3

802.11a

CHANNEL	TX Channel 100	DETECTOR FUNCTION	Peak (PK)
FREQUENCY RANGE	1GHz ~ 40GHz		Average (AV)

ANTENNA POLARITY & TEST DISTANCE: HORIZONTAL AT 3 M										
FREQ. (MHz)	EMISSION LEVEL (dBuV/m)	READ LEVEL (dBuV)	LIMIT (dBuV/m)	MARGIN (dB)	ANTENNA FACTOR (dB /m)	CABLE LOSS (dB)	PREAMP FACTOR (dB)	ANTENNA HEIGHT (cm)	TABLE ANGLE (Degree)	REMARK
5460	51.9	52.61	74	-22.1	34.38	11.52	46.61	100	190	Peak
5460	46.42	47.13	54	-7.58	34.38	11.52	46.61	100	190	Average
5470	53.56	54.25	68.2	-14.64	34.39	11.53	46.61	100	190	Peak
5500	103.26	103.92	74	29.26	34.4	11.56	46.62	100	190	Peak
5500	96.82	97.48	54	42.82	34.4	11.56	46.62	100	190	Average

ANTENNA POLARITY & TEST DISTANCE: VERTICAL AT 3 M										
FREQ. (MHz)	EMISSION LEVEL (dBuV/m)	READ LEVEL (dBuV)	LIMIT (dBuV/m)	MARGIN (dB)	ANTENNA FACTOR (dB /m)	CABLE LOSS (dB)	PREAMP FACTOR (dB)	ANTENNA HEIGHT (cm)	TABLE ANGLE (Degree)	REMARK
5460	51.82	52.24	74	-22.18	34.67	11.52	46.61	100	265	Peak
5460	45.73	46.15	54	-8.27	34.67	11.52	46.61	100	265	Average
5470	54.18	54.58	68.2	-14.02	34.68	11.53	46.61	100	265	Peak
5500	98.11	98.47	74	24.11	34.7	11.56	46.62	100	265	Peak
5500	90.38	90.74	54	36.38	34.7	11.56	46.62	100	265	Average

REMARKS:

- Emission Level = Read Level+ Antenna Factor + Cable Loss- Preamp Factor
Margin value = Emission level – Limit value.
- 5500MHz: Fundamental frequency.
- #: Out of restricted band.



CHANNEL	TX Channel 116	DETECTOR FUNCTION	Peak (PK)
FREQUENCY RANGE	1GHz ~ 40GHz		Average (AV)

ANTENNA POLARITY & TEST DISTANCE: HORIZONTAL AT 3 M

FREQ. (MHz)	EMISSION LEVEL (dBuV/m)	READ LEVEL (dBuV)	LIMIT (dBuV/m)	MARGIN (dB)	ANTENNA FACTOR (dB /m)	CABLE LOSS (dB)	PREAMP FACTOR (dB)	ANTENNA HEIGHT (cm)	TABLE ANGLE (Degree)	REMARK
5460	53.02	53.73	74	-20.98	34.38	11.52	46.61	100	185	Peak
5460	47.55	48.26	54	-6.45	34.38	11.52	46.61	100	185	Average
5470	53.54	54.23	68.2	-14.66	34.39	11.53	46.61	100	185	Peak
5580	102.45	102.96	74	28.45	34.54	11.59	46.64	100	185	Peak
5580	96.08	96.59	54	42.08	34.54	11.59	46.64	100	185	Average

ANTENNA POLARITY & TEST DISTANCE: VERTICAL AT 3 M

FREQ. (MHz)	EMISSION LEVEL (dBuV/m)	READ LEVEL (dBuV)	LIMIT (dBuV/m)	MARGIN (dB)	ANTENNA FACTOR (dB /m)	CABLE LOSS (dB)	PREAMP FACTOR (dB)	ANTENNA HEIGHT (cm)	TABLE ANGLE (Degree)	REMARK
5460	53.52	53.94	74	-20.48	34.67	11.52	46.61	100	270	Peak
5460	47.78	48.2	54	-6.22	34.67	11.52	46.61	100	270	Average
5470	55.41	55.81	68.2	-12.79	34.68	11.53	46.61	100	270	Peak
5580	95.9	96.12	74	21.9	34.83	11.59	46.64	100	270	Peak
5580	90.53	90.75	54	36.53	34.83	11.59	46.64	100	270	Average

REMARKS:

- Emission Level = Read Level+ Antenna Factor + Cable Loss- Preamp Factor
Margin value = Emission level – Limit value.
- 5580MHz: Fundamental frequency.
- #: Out of restricted band.



CHANNEL	TX Channel 144	DETECTOR FUNCTION	Peak (PK)
FREQUENCY RANGE	1GHz ~ 40GHz		Average (AV)

ANTENNA POLARITY & TEST DISTANCE: HORIZONTAL AT 3 M										
FREQ. (MHz)	EMISSION LEVEL (dBuV/m)	READ LEVEL (dBuV)	LIMIT (dBuV/m)	MARGIN (dB)	ANTENNA FACTOR (dB /m)	CABLE LOSS (dB)	PREAMP FACTOR (dB)	ANTENNA HEIGHT (cm)	TABLE ANGLE (Degree)	REMARK
5470	53.19	53.88	68.2	-15.01	34.39	11.53	46.61	100	185	Peak
5720	100.91	101.15	74	26.91	34.8	11.64	46.68	100	185	Peak
5720	95.53	95.77	54	41.53	34.8	11.64	46.68	100	185	Average
5850	54.85	54.85	68.2	-13.35	35.03	11.69	46.72	100	185	Peak
ANTENNA POLARITY & TEST DISTANCE: VERTICAL AT 3 M										
FREQ. (MHz)	EMISSION LEVEL (dBuV/m)	READ LEVEL (dBuV)	LIMIT (dBuV/m)	MARGIN (dB)	ANTENNA FACTOR (dB /m)	CABLE LOSS (dB)	PREAMP FACTOR (dB)	ANTENNA HEIGHT (cm)	TABLE ANGLE (Degree)	REMARK
5470	52.25	52.65	68.2	-15.95	34.68	11.53	46.61	100	270	Peak
5720	94.26	94.25	74	20.26	35.05	11.64	46.68	100	270	Peak
5720	88.39	88.38	54	34.39	35.05	11.64	46.68	100	270	Average
5850	54.16	53.93	68.2	-14.04	35.26	11.69	46.72	100	270	Peak

REMARKS:

- Emission Level = Read Level+ Antenna Factor + Cable Loss- Preamp Factor
Margin value = Emission level – Limit value.
- 5720MHz: Fundamental frequency.
- #: Out of restricted band.



802.11n (20MHz)

CHANNEL	TX Channel 100	DETECTOR FUNCTION	Peak (PK)
FREQUENCY RANGE	1GHz ~ 40GHz		Average (AV)

ANTENNA POLARITY & TEST DISTANCE: HORIZONTAL AT 3 M										
FREQ. (MHz)	EMISSION LEVEL (dBuV/m)	READ LEVEL (dBuV)	LIMIT (dBuV/m)	MARGIN (dB)	ANTENNA FACTOR (dB /m)	CABLE LOSS (dB)	PREAMP FACTOR (dB)	ANTENNA HEIGHT (cm)	TABLE ANGLE (Degree)	REMARK
5460	52.05	52.76	74	-21.95	34.38	11.52	46.61	100	190	Peak
5460	46.5	47.21	54	-7.5	34.38	11.52	46.61	100	190	Average
5470	52.75	53.44	68.2	-15.45	34.39	11.53	46.61	100	190	Peak
5500	100.8	101.46	74	26.8	34.4	11.56	46.62	100	190	Peak
5500	96.17	96.83	54	42.17	34.4	11.56	46.62	100	190	Average

ANTENNA POLARITY & TEST DISTANCE: VERTICAL AT 3 M										
FREQ. (MHz)	EMISSION LEVEL (dBuV/m)	READ LEVEL (dBuV)	LIMIT (dBuV/m)	MARGIN (dB)	ANTENNA FACTOR (dB /m)	CABLE LOSS (dB)	PREAMP FACTOR (dB)	ANTENNA HEIGHT (cm)	TABLE ANGLE (Degree)	REMARK
5460	51.9	52.32	74	-22.1	34.67	11.52	46.61	100	280	Peak
5460	46.32	46.74	54	-7.68	34.67	11.52	46.61	100	280	Average
5470	51.75	52.15	68.2	-16.45	34.68	11.53	46.61	100	280	Peak
5500	94.67	95.03	74	20.67	34.7	11.56	46.62	100	280	Peak
5500	88.33	88.69	54	34.33	34.7	11.56	46.62	100	280	Average

REMARKS:

- Emission Level = Read Level+ Antenna Factor + Cable Loss- Preamp Factor
Margin value = Emission level – Limit value.
- 5500MHz: Fundamental frequency.
- #: Out of restricted band.



CHANNEL	TX Channel 116	DETECTOR FUNCTION	Peak (PK)
FREQUENCY RANGE	1GHz ~ 40GHz		Average (AV)

ANTENNA POLARITY & TEST DISTANCE: HORIZONTAL AT 3 M

FREQ. (MHz)	EMISSION LEVEL (dBuV/m)	READ LEVEL (dBuV)	LIMIT (dBuV/m)	MARGIN (dB)	ANTENNA FACTOR (dB /m)	CABLE LOSS (dB)	PREAMP FACTOR (dB)	ANTENNA HEIGHT (cm)	TABLE ANGLE (Degree)	REMARK
5460	53.52	54.23	74	-20.48	34.38	11.52	46.61	100	190	Peak
5460	45.98	46.69	54	-8.02	34.38	11.52	46.61	100	190	Average
5470	50.89	51.58	68.2	-17.31	34.39	11.53	46.61	100	190	Peak
5580	100.96	101.47	74	26.96	34.54	11.59	46.64	100	190	Peak
5580	95.8	96.31	54	41.8	34.54	11.59	46.64	100	190	Average

ANTENNA POLARITY & TEST DISTANCE: VERTICAL AT 3 M

FREQ. (MHz)	EMISSION LEVEL (dBuV/m)	READ LEVEL (dBuV)	LIMIT (dBuV/m)	MARGIN (dB)	ANTENNA FACTOR (dB /m)	CABLE LOSS (dB)	PREAMP FACTOR (dB)	ANTENNA HEIGHT (cm)	TABLE ANGLE (Degree)	REMARK
5460	53.89	54.31	74	-20.11	34.67	11.52	46.61	100	290	Peak
5460	46.25	46.67	54	-7.75	34.67	11.52	46.61	100	290	Average
5470	51.98	52.38	68.2	-16.22	34.68	11.53	46.61	100	290	Peak
5580	95.69	95.91	74	21.69	34.83	11.59	46.64	100	290	Peak
5580	89.87	90.09	54	35.87	34.83	11.59	46.64	100	290	Average

REMARKS:

- Emission Level = Read Level+ Antenna Factor + Cable Loss- Preamp Factor
Margin value = Emission level – Limit value.
- 5580MHz: Fundamental frequency.
- #: Out of restricted band.



CHANNEL	TX Channel 144	DETECTOR FUNCTION	Peak (PK)
FREQUENCY RANGE	1GHz ~ 40GHz		Average (AV)

ANTENNA POLARITY & TEST DISTANCE: HORIZONTAL AT 3 M										
FREQ. (MHz)	EMISSION LEVEL (dBuV/m)	READ LEVEL (dBuV)	LIMIT (dBuV/m)	MARGIN (dB)	ANTENNA FACTOR (dB /m)	CABLE LOSS (dB)	PREAMP FACTOR (dB)	ANTENNA HEIGHT (cm)	TABLE ANGLE (Degree)	REMARK
5470	51.74	52.43	68.2	-16.46	34.39	11.53	46.61	100	195	Peak
5720	100.33	100.57	74	26.33	34.8	11.64	46.68	100	195	Peak
5720	94.94	95.18	54	40.94	34.8	11.64	46.68	100	195	Average
5850	51.81	51.81	68.2	-16.39	35.03	11.69	46.72	100	195	Peak
ANTENNA POLARITY & TEST DISTANCE: VERTICAL AT 3 M										
FREQ. (MHz)	EMISSION LEVEL (dBuV/m)	READ LEVEL (dBuV)	LIMIT (dBuV/m)	MARGIN (dB)	ANTENNA FACTOR (dB /m)	CABLE LOSS (dB)	PREAMP FACTOR (dB)	ANTENNA HEIGHT (cm)	TABLE ANGLE (Degree)	REMARK
5470	51.57	51.97	68.2	-16.63	34.68	11.53	46.61	100	265	Peak
5720	94.07	94.06	74	20.07	35.05	11.64	46.68	100	265	Peak
5720	88.68	88.67	54	34.68	35.05	11.64	46.68	100	265	Average
5850	52.54	52.31	68.2	-15.66	35.26	11.69	46.72	100	265	Peak

REMARKS:

- Emission Level = Read Level+ Antenna Factor + Cable Loss- Preamp Factor
Margin value = Emission level – Limit value.
- 5720MHz: Fundamental frequency.
- #: Out of restricted band.



802.11n (40MHz)

CHANNEL	TX Channel 102	DETECTOR FUNCTION	Peak (PK)
FREQUENCY RANGE	1GHz ~ 40GHz		Average (AV)

ANTENNA POLARITY & TEST DISTANCE: HORIZONTAL AT 3 M

FREQ. (MHz)	EMISSION LEVEL (dBuV/m)	READ LEVEL (dBuV)	LIMIT (dBuV/m)	MARGIN (dB)	ANTENNA FACTOR (dB /m)	CABLE LOSS (dB)	PREAMP FACTOR (dB)	ANTENNA HEIGHT (cm)	TABLE ANGLE (Degree)	REMARK
5460	50.46	51.17	74	-23.54	34.38	11.52	46.61	100	190	Peak
5460	46.79	47.5	54	-7.21	34.38	11.52	46.61	100	190	Average
5470	53.48	54.17	68.2	-14.72	34.39	11.53	46.61	100	190	Peak
5510	97	97.64	74	23	34.42	11.56	46.62	100	190	Peak
5510	91.47	92.11	54	37.47	34.42	11.56	46.62	100	190	Average

ANTENNA POLARITY & TEST DISTANCE: VERTICAL AT 3 M

FREQ. (MHz)	EMISSION LEVEL (dBuV/m)	READ LEVEL (dBuV)	LIMIT (dBuV/m)	MARGIN (dB)	ANTENNA FACTOR (dB /m)	CABLE LOSS (dB)	PREAMP FACTOR (dB)	ANTENNA HEIGHT (cm)	TABLE ANGLE (Degree)	REMARK
5460	50.2	50.62	74	-23.8	34.67	11.52	46.61	100	275	Peak
5460	46.79	47.21	54	-7.21	34.67	11.52	46.61	100	275	Average
5470	52.35	52.75	68.2	-15.85	34.68	11.53	46.61	100	275	Peak
5510	91.21	91.55	74	17.21	34.72	11.56	46.62	100	275	Peak
5510	86.12	86.46	54	32.12	34.72	11.56	46.62	100	275	Average

REMARKS:

- Emission Level = Read Level+ Antenna Factor + Cable Loss- Preamp Factor
Margin value = Emission level – Limit value.
- 5510MHz: Fundamental frequency.
- #: Out of restricted band.



CHANNEL	TX Channel 110	DETECTOR FUNCTION	Peak (PK)
FREQUENCY RANGE	1GHz ~ 40GHz		Average (AV)

ANTENNA POLARITY & TEST DISTANCE: HORIZONTAL AT 3 M

FREQ. (MHz)	EMISSION LEVEL (dBuV/m)	READ LEVEL (dBuV)	LIMIT (dBuV/m)	MARGIN (dB)	ANTENNA FACTOR (dB /m)	CABLE LOSS (dB)	PREAMP FACTOR (dB)	ANTENNA HEIGHT (cm)	TABLE ANGLE (Degree)	REMARK
5460	49.77	50.48	74	-24.23	34.38	11.52	46.61	100	190	Peak
5460	46.92	47.63	54	-7.08	34.38	11.52	46.61	100	190	Average
5470	52.03	52.72	68.2	-16.17	34.39	11.53	46.61	100	190	Peak
5550	97.17	97.73	74	23.17	34.49	11.58	46.63	100	190	Peak
5550	91.33	91.89	54	37.33	34.49	11.58	46.63	100	190	Average

ANTENNA POLARITY & TEST DISTANCE: VERTICAL AT 3 M

FREQ. (MHz)	EMISSION LEVEL (dBuV/m)	READ LEVEL (dBuV)	LIMIT (dBuV/m)	MARGIN (dB)	ANTENNA FACTOR (dB /m)	CABLE LOSS (dB)	PREAMP FACTOR (dB)	ANTENNA HEIGHT (cm)	TABLE ANGLE (Degree)	REMARK
5460	50.27	50.69	74	-23.73	34.67	11.52	46.61	100	275	Peak
5460	46.52	46.94	54	-7.48	34.67	11.52	46.61	100	275	Average
5470	50.93	51.33	68.2	-17.27	34.68	11.53	46.61	100	275	Peak
5550	91.17	91.44	74	17.17	34.78	11.58	46.63	100	275	Peak
5550	85.53	85.8	54	31.53	34.78	11.58	46.63	100	275	Average

REMARKS:

- Emission Level = Read Level+ Antenna Factor + Cable Loss- Preamp Factor
Margin value = Emission level – Limit value.
- 5500MHz: Fundamental frequency.
- #: Out of restricted band.



CHANNEL	TX Channel 142	DETECTOR FUNCTION	Peak (PK)
FREQUENCY RANGE	1GHz ~ 40GHz		Average (AV)

ANTENNA POLARITY & TEST DISTANCE: HORIZONTAL AT 3 M										
FREQ. (MHz)	EMISSION LEVEL (dBuV/m)	READ LEVEL (dBuV)	LIMIT (dBuV/m)	MARGIN (dB)	ANTENNA FACTOR (dB /m)	CABLE LOSS (dB)	PREAMP FACTOR (dB)	ANTENNA HEIGHT (cm)	TABLE ANGLE (Degree)	REMARK
5470	49.56	50.25	68.2	-18.64	34.39	11.53	46.61	100	190	Peak
5710	94.73	94.99	74	20.73	34.78	11.64	46.68	100	190	Peak
5710	89.92	90.18	54	35.92	34.78	11.64	46.68	100	190	Average
5850	51.36	51.36	68.2	-16.84	35.03	11.69	46.72	100	190	Peak
ANTENNA POLARITY & TEST DISTANCE: VERTICAL AT 3 M										
FREQ. (MHz)	EMISSION LEVEL (dBuV/m)	READ LEVEL (dBuV)	LIMIT (dBuV/m)	MARGIN (dB)	ANTENNA FACTOR (dB /m)	CABLE LOSS (dB)	PREAMP FACTOR (dB)	ANTENNA HEIGHT (cm)	TABLE ANGLE (Degree)	REMARK
5470	51.69	52.09	68.2	-16.51	34.68	11.53	46.61	100	285	Peak
5710	88.69	88.69	74	14.69	35.04	11.64	46.68	100	285	Peak
5710	84.72	84.72	54	30.72	35.04	11.64	46.68	100	285	Average
5850	51.51	51.28	68.2	-16.69	35.26	11.69	46.72	100	285	Peak

REMARKS:

1. Emission Level = Read Level+ Antenna Factor + Cable Loss- Preamp Factor
Margin value = Emission level – Limit value.
2. 5710MHz: Fundamental frequency.
3. #: Out of restricted band.



802.11ac (20MHz)

CHANNEL	TX Channel 100	DETECTOR FUNCTION	Peak (PK)
FREQUENCY RANGE	1GHz ~ 40GHz		Average (AV)

ANTENNA POLARITY & TEST DISTANCE: HORIZONTAL AT 3 M

FREQ. (MHz)	EMISSION LEVEL (dBuV/m)	READ LEVEL (dBuV)	LIMIT (dBuV/m)	MARGIN (dB)	ANTENNA FACTOR (dB /m)	CABLE LOSS (dB)	PREAMP FACTOR (dB)	ANTENNA HEIGHT (cm)	TABLE ANGLE (Degree)	REMARK
5460	52.44	53.15	74	-21.56	34.38	11.52	46.61	100	190	Peak
5460	46.75	47.46	54	-7.25	34.38	11.52	46.61	100	190	Average
5470	53.03	53.72	68.2	-15.17	34.39	11.53	46.61	100	190	Peak
5500	102.24	102.9	74	28.24	34.4	11.56	46.62	100	190	Peak
5500	96.29	96.95	54	42.29	34.4	11.56	46.62	100	190	Average

ANTENNA POLARITY & TEST DISTANCE: VERTICAL AT 3 M

FREQ. (MHz)	EMISSION LEVEL (dBuV/m)	READ LEVEL (dBuV)	LIMIT (dBuV/m)	MARGIN (dB)	ANTENNA FACTOR (dB /m)	CABLE LOSS (dB)	PREAMP FACTOR (dB)	ANTENNA HEIGHT (cm)	TABLE ANGLE (Degree)	REMARK
5460	52.09	52.51	74	-21.91	34.67	11.52	46.61	100	280	Peak
5460	46.34	46.76	54	-7.66	34.67	11.52	46.61	100	280	Average
5470	52.21	52.61	68.2	-15.99	34.68	11.53	46.61	100	280	Peak
5500	96.69	97.05	74	22.69	34.7	11.56	46.62	100	280	Peak
5500	88.65	89.01	54	34.65	34.7	11.56	46.62	100	280	Average

REMARKS:

- Emission Level = Read Level+ Antenna Factor + Cable Loss- Preamp Factor
Margin value = Emission level – Limit value.
- 5500MHz: Fundamental frequency.
- #: Out of restricted band.



CHANNEL	TX Channel 116	DETECTOR FUNCTION	Peak (PK)
FREQUENCY RANGE	1GHz ~ 40GHz		Average (AV)

ANTENNA POLARITY & TEST DISTANCE: HORIZONTAL AT 3 M										
FREQ. (MHz)	EMISSION LEVEL (dBuV/m)	READ LEVEL (dBuV)	LIMIT (dBuV/m)	MARGIN (dB)	ANTENNA FACTOR (dB /m)	CABLE LOSS (dB)	PREAMP FACTOR (dB)	ANTENNA HEIGHT (cm)	TABLE ANGLE (Degree)	REMARK
5460	50.87	51.58	74	-23.13	34.38	11.52	46.61	100	190	Peak
5460	45.91	46.62	54	-8.09	34.38	11.52	46.61	100	190	Average
5470	53.07	53.76	68.2	-15.13	34.39	11.53	46.61	100	190	Peak
5580	101.13	101.64	74	27.13	34.54	11.59	46.64	100	190	Peak
5580	95.27	95.78	54	41.27	34.54	11.59	46.64	100	190	Average
ANTENNA POLARITY & TEST DISTANCE: VERTICAL AT 3 M										
FREQ. (MHz)	EMISSION LEVEL (dBuV/m)	READ LEVEL (dBuV)	LIMIT (dBuV/m)	MARGIN (dB)	ANTENNA FACTOR (dB /m)	CABLE LOSS (dB)	PREAMP FACTOR (dB)	ANTENNA HEIGHT (cm)	TABLE ANGLE (Degree)	REMARK
5460	52.14	52.56	74	-21.86	34.67	11.52	46.61	100	270	Peak
5460	46.14	46.56	54	-7.86	34.67	11.52	46.61	100	270	Average
5470	53.05	53.45	68.2	-15.15	34.68	11.53	46.61	100	270	Peak
5580	96.01	96.23	74	22.01	34.83	11.59	46.64	100	270	Peak
5580	89.3	89.52	54	35.3	34.83	11.59	46.64	100	270	Average

REMARKS:

- Emission Level = Read Level+ Antenna Factor + Cable Loss- Preamp Factor
Margin value = Emission level – Limit value.
- 5580MHz: Fundamental frequency.
- #: Out of restricted band.



CHANNEL	TX Channel 144	DETECTOR FUNCTION	Peak (PK)
FREQUENCY RANGE	1GHz ~ 40GHz		Average (AV)

ANTENNA POLARITY & TEST DISTANCE: HORIZONTAL AT 3 M

FREQ. (MHz)	EMISSION LEVEL (dBuV/m)	READ LEVEL (dBuV)	LIMIT (dBuV/m)	MARGIN (dB)	ANTENNA FACTOR (dB /m)	CABLE LOSS (dB)	PREAMP FACTOR (dB)	ANTENNA HEIGHT (cm)	TABLE ANGLE (Degree)	REMARK
5470	52.23	52.92	68.2	-15.97	34.39	11.53	46.61	100	190	Peak
5720	99.29	99.53	74	25.29	34.8	11.64	46.68	100	190	Peak
5720	94.79	95.03	54	40.79	34.8	11.64	46.68	100	190	Average
5850	53.22	53.22	68.2	-14.98	35.03	11.69	46.72	100	190	Peak

ANTENNA POLARITY & TEST DISTANCE: VERTICAL AT 3 M

FREQ. (MHz)	EMISSION LEVEL (dBuV/m)	READ LEVEL (dBuV)	LIMIT (dBuV/m)	MARGIN (dB)	ANTENNA FACTOR (dB /m)	CABLE LOSS (dB)	PREAMP FACTOR (dB)	ANTENNA HEIGHT (cm)	TABLE ANGLE (Degree)	REMARK
5470	51.88	52.28	68.2	-16.32	34.68	11.53	46.61	100	285	Peak
5720	94.17	94.16	74	20.17	35.05	11.64	46.68	100	285	Peak
5720	88.45	88.44	54	34.45	35.05	11.64	46.68	100	285	Average
5850	54.9	54.67	68.2	-13.3	35.26	11.69	46.72	100	285	Peak

REMARKS:

- Emission Level = Read Level+ Antenna Factor + Cable Loss- Preamp Factor
Margin value = Emission level – Limit value.
- 5720MHz: Fundamental frequency.
- #: Out of restricted band.



802.11ac (40MHz)

CHANNEL	TX Channel 102	DETECTOR FUNCTION	Peak (PK)
FREQUENCY RANGE	1GHz ~ 40GHz		Average (AV)

ANTENNA POLARITY & TEST DISTANCE: HORIZONTAL AT 3 M										
FREQ. (MHz)	EMISSION LEVEL (dBuV/m)	READ LEVEL (dBuV)	LIMIT (dBuV/m)	MARGIN (dB)	ANTENNA FACTOR (dB /m)	CABLE LOSS (dB)	PREAMP FACTOR (dB)	ANTENNA HEIGHT (cm)	TABLE ANGLE (Degree)	REMARK
5460	54.65	55.36	74	-19.35	34.38	11.52	46.61	100	190	Peak
5460	47.1	47.81	54	-6.9	34.38	11.52	46.61	100	190	Average
5470	52.37	53.06	68.2	-15.83	34.39	11.53	46.61	100	190	Peak
5510	96.81	97.45	74	22.81	34.42	11.56	46.62	100	190	Peak
5510	92.22	92.86	54	38.22	34.42	11.56	46.62	100	190	Average
ANTENNA POLARITY & TEST DISTANCE: VERTICAL AT 3 M										
FREQ. (MHz)	EMISSION LEVEL (dBuV/m)	READ LEVEL (dBuV)	LIMIT (dBuV/m)	MARGIN (dB)	ANTENNA FACTOR (dB /m)	CABLE LOSS (dB)	PREAMP FACTOR (dB)	ANTENNA HEIGHT (cm)	TABLE ANGLE (Degree)	REMARK
5460	49.65	50.07	74	-24.35	34.67	11.52	46.61	100	265	Peak
5460	46.83	47.25	54	-7.17	34.67	11.52	46.61	100	265	Average
5470	51.78	52.18	68.2	-16.42	34.68	11.53	46.61	100	265	Peak
5510	91.28	91.62	74	17.28	34.72	11.56	46.62	100	265	Peak
5510	85.86	86.2	54	31.86	34.72	11.56	46.62	100	265	Average

REMARKS:

- Emission Level = Read Level+ Antenna Factor + Cable Loss- Preamp Factor
Margin value = Emission level – Limit value.
- 5510MHz: Fundamental frequency.
- #: Out of restricted band.



CHANNEL	TX Channel 110	DETECTOR FUNCTION	Peak (PK)
FREQUENCY RANGE	1GHz ~ 40GHz		Average (AV)

ANTENNA POLARITY & TEST DISTANCE: HORIZONTAL AT 3 M										
FREQ. (MHz)	EMISSION LEVEL (dBuV/m)	READ LEVEL (dBuV)	LIMIT (dBuV/m)	MARGIN (dB)	ANTENNA FACTOR (dB /m)	CABLE LOSS (dB)	PREAMP FACTOR (dB)	ANTENNA HEIGHT (cm)	TABLE ANGLE (Degree)	REMARK
5460	49.62	50.33	74	-24.38	34.38	11.52	46.61	100	190	Peak
5460	46.49	47.2	54	-7.51	34.38	11.52	46.61	100	190	Average
5470	50.89	51.58	68.2	-17.31	34.39	11.53	46.61	100	190	Peak
5550	96.73	97.29	74	22.73	34.49	11.58	46.63	100	190	Peak
5550	91.88	92.44	54	37.88	34.49	11.58	46.63	100	190	Average
ANTENNA POLARITY & TEST DISTANCE: VERTICAL AT 3 M										
FREQ. (MHz)	EMISSION LEVEL (dBuV/m)	READ LEVEL (dBuV)	LIMIT (dBuV/m)	MARGIN (dB)	ANTENNA FACTOR (dB /m)	CABLE LOSS (dB)	PREAMP FACTOR (dB)	ANTENNA HEIGHT (cm)	TABLE ANGLE (Degree)	REMARK
5460	51.2	51.62	74	-22.8	34.67	11.52	46.61	100	275	Peak
5460	46.77	47.19	54	-7.23	34.67	11.52	46.61	100	275	Average
5470	51.53	51.93	68.2	-16.67	34.68	11.53	46.61	100	275	Peak
5550	90.68	90.95	74	16.68	34.78	11.58	46.63	100	275	Peak
5550	86.33	86.6	54	32.33	34.78	11.58	46.63	100	275	Average

REMARKS:

- Emission Level = Read Level+ Antenna Factor + Cable Loss- Preamp Factor
Margin value = Emission level – Limit value.
- 5500MHz: Fundamental frequency.
- #: Out of restricted band.



CHANNEL	TX Channel 142	DETECTOR FUNCTION	Peak (PK)
FREQUENCY RANGE	1GHz ~ 40GHz		Average (AV)

ANTENNA POLARITY & TEST DISTANCE: HORIZONTAL AT 3 M

FREQ. (MHz)	EMISSION LEVEL (dBuV/m)	READ LEVEL (dBuV)	LIMIT (dBuV/m)	MARGIN (dB)	ANTENNA FACTOR (dB /m)	CABLE LOSS (dB)	PREAMP FACTOR (dB)	ANTENNA HEIGHT (cm)	TABLE ANGLE (Degree)	REMARK
5470	51.57	52.26	68.2	-16.63	34.39	11.53	46.61	100	190	Peak
5710	95.19	95.45	74	21.19	34.78	11.64	46.68	100	190	Peak
5710	91.02	91.28	54	37.02	34.78	11.64	46.68	100	190	Average
5850	51.53	51.53	68.2	-16.67	35.03	11.69	46.72	100	190	Peak

ANTENNA POLARITY & TEST DISTANCE: VERTICAL AT 3 M

FREQ. (MHz)	EMISSION LEVEL (dBuV/m)	READ LEVEL (dBuV)	LIMIT (dBuV/m)	MARGIN (dB)	ANTENNA FACTOR (dB /m)	CABLE LOSS (dB)	PREAMP FACTOR (dB)	ANTENNA HEIGHT (cm)	TABLE ANGLE (Degree)	REMARK
5470	52.92	53.32	68.2	-15.28	34.68	11.53	46.61	100	270	Peak
5710	89.36	89.36	74	15.36	35.04	11.64	46.68	100	270	Peak
5710	84.07	84.07	54	30.07	35.04	11.64	46.68	100	270	Average
5850	53.67	53.44	68.2	-14.53	35.26	11.69	46.72	100	270	Peak

REMARKS:

- Emission Level = Read Level+ Antenna Factor + Cable Loss- Preamp Factor
Margin value = Emission level – Limit value.
- 5710MHz: Fundamental frequency.
- #: Out of restricted band.



802.11ac (80MHz)

CHANNEL	TX Channel 106	DETECTOR FUNCTION	Peak (PK)
FREQUENCY RANGE	1GHz ~ 40GHz		Average (AV)

ANTENNA POLARITY & TEST DISTANCE: HORIZONTAL AT 3 M

FREQ. (MHz)	EMISSION LEVEL (dBuV/m)	READ LEVEL (dBuV)	LIMIT (dBuV/m)	MARGIN (dB)	ANTENNA FACTOR (dB /m)	CABLE LOSS (dB)	PREAMP FACTOR (dB)	ANTENNA HEIGHT (cm)	TABLE ANGLE (Degree)	REMARK
5460	51.55	52.26	74	-22.45	34.38	11.52	46.61	100	190	Peak
5460	47.43	48.14	54	-6.57	34.38	11.52	46.61	100	190	Average
5470	53.09	53.78	68.2	-15.11	34.39	11.53	46.61	100	190	Peak
5530	92.5	93.11	74	18.5	34.45	11.57	46.63	100	190	Peak
5530	88.04	88.65	54	34.04	34.45	11.57	46.63	100	190	Average

ANTENNA POLARITY & TEST DISTANCE: VERTICAL AT 3 M

FREQ. (MHz)	EMISSION LEVEL (dBuV/m)	READ LEVEL (dBuV)	LIMIT (dBuV/m)	MARGIN (dB)	ANTENNA FACTOR (dB /m)	CABLE LOSS (dB)	PREAMP FACTOR (dB)	ANTENNA HEIGHT (cm)	TABLE ANGLE (Degree)	REMARK
5460	52.36	52.78	74	-21.64	34.67	11.52	46.61	100	275	Peak
5460	47.19	47.61	54	-6.81	34.67	11.52	46.61	100	275	Average
5470	52.51	52.91	68.2	-15.69	34.68	11.53	46.61	100	275	Peak
5530	86.92	87.23	74	12.92	34.75	11.57	46.63	100	275	Peak
5530	81.74	82.05	54	27.74	34.75	11.57	46.63	100	275	Average

REMARKS:

- Emission Level = Read Level+ Antenna Factor + Cable Loss- Preamp Factor
Margin value = Emission level – Limit value.
- 5530MHz: Fundamental frequency.
- #: Out of restricted band.



CHANNEL	TX Channel 122	DETECTOR FUNCTION	Peak (PK)
FREQUENCY RANGE	1GHz ~ 40GHz		Average (AV)

ANTENNA POLARITY & TEST DISTANCE: HORIZONTAL AT 3 M

FREQ. (MHz)	EMISSION LEVEL (dBuV/m)	READ LEVEL (dBuV)	LIMIT (dBuV/m)	MARGIN (dB)	ANTENNA FACTOR (dB /m)	CABLE LOSS (dB)	PREAMP FACTOR (dB)	ANTENNA HEIGHT (cm)	TABLE ANGLE (Degree)	REMARK
5460	52.11	52.82	74	-21.89	34.38	11.52	46.61	100	190	Peak
5460	46.68	47.39	54	-7.32	34.38	11.52	46.61	100	190	Average
5470	52.58	53.27	68.2	-15.62	34.39	11.53	46.61	100	190	Peak
5610	92.62	93.07	74	18.62	34.6	11.6	46.65	100	190	Peak
5610	87.74	88.19	54	33.74	34.6	11.6	46.65	100	190	Average

ANTENNA POLARITY & TEST DISTANCE: VERTICAL AT 3 M

FREQ. (MHz)	EMISSION LEVEL (dBuV/m)	READ LEVEL (dBuV)	LIMIT (dBuV/m)	MARGIN (dB)	ANTENNA FACTOR (dB /m)	CABLE LOSS (dB)	PREAMP FACTOR (dB)	ANTENNA HEIGHT (cm)	TABLE ANGLE (Degree)	REMARK
5460	52.08	52.5	74	-21.92	34.67	11.52	46.61	100	275	Peak
5460	47.43	47.85	54	-6.57	34.67	11.52	46.61	100	275	Average
5470	49.7	50.1	68.2	-18.5	34.68	11.53	46.61	100	275	Peak
5610	86.71	86.88	74	12.71	34.88	11.6	46.65	100	275	Peak
5610	81.45	81.62	54	27.45	34.88	11.6	46.65	100	275	Average

REMARKS:

- Emission Level = Read Level+ Antenna Factor + Cable Loss- Preamp Factor
Margin value = Emission level – Limit value.
- 5610MHz: Fundamental frequency.
- #: Out of restricted band.



CHANNEL	TX Channel 138	DETECTOR FUNCTION	Peak (PK)
FREQUENCY RANGE	1GHz ~ 40GHz		Average (AV)

ANTENNA POLARITY & TEST DISTANCE: HORIZONTAL AT 3 M

FREQ. (MHz)	EMISSION LEVEL (dBuV/m)	READ LEVEL (dBuV)	LIMIT (dBuV/m)	MARGIN (dB)	ANTENNA FACTOR (dB /m)	CABLE LOSS (dB)	PREAMP FACTOR (dB)	ANTENNA HEIGHT (cm)	TABLE ANGLE (Degree)	REMARK
5470	52.21	52.9	68.2	-15.99	34.39	11.53	46.61	100	190	Peak
5690	91.97	92.27	74	17.97	34.74	11.63	46.67	100	190	Peak
5690	86.05	86.35	54	32.05	34.74	11.63	46.67	100	190	Average
5850	51.12	51.12	68.2	-17.08	35.03	11.69	46.72	100	190	Peak

ANTENNA POLARITY & TEST DISTANCE: VERTICAL AT 3 M

FREQ. (MHz)	EMISSION LEVEL (dBuV/m)	READ LEVEL (dBuV)	LIMIT (dBuV/m)	MARGIN (dB)	ANTENNA FACTOR (dB /m)	CABLE LOSS (dB)	PREAMP FACTOR (dB)	ANTENNA HEIGHT (cm)	TABLE ANGLE (Degree)	REMARK
5470	51.28	51.68	68.2	-16.92	34.68	11.53	46.61	100	275	Peak
5690	86.47	86.51	74	12.47	35	11.63	46.67	100	275	Peak
5690	82.61	82.65	54	28.61	35	11.63	46.67	100	275	Average
5850	53.15	52.92	68.2	-15.05	35.26	11.69	46.72	100	275	Peak

REMARKS:

- Emission Level = Read Level+ Antenna Factor + Cable Loss- Preamp Factor
Margin value = Emission level – Limit value.
- 5690MHz: Fundamental frequency.
- #: Out of restricted band.



802.11a

Worst case harmonic:

CHANNEL	TX Channel 116	DETECTOR FUNCTION	Peak (PK)
FREQUENCY RANGE	1GHz ~ 40GHz		Average (AV)

ANTENNA POLARITY & TEST DISTANCE: HORIZONTAL AT 3 M

	Freq	Level	Read Level	Limit Line	Over Limit	Factor	Remark	Pol/Phase
	MHz	dBuV/m	dBuV	dBuV/m	dB	dB/m		
1	11166.000	52.48	43.62	74.00	-21.52	8.86	Peak	Horizontal
2	11166.000	46.11	37.25	54.00	-7.89	8.86	Average	Horizontal
3	PK16740.000	58.65	41.93	74.00	-15.35	16.72	Peak	Horizontal
4	PP16740.000	48.58	31.86	54.00	-5.42	16.72	Average	Horizontal

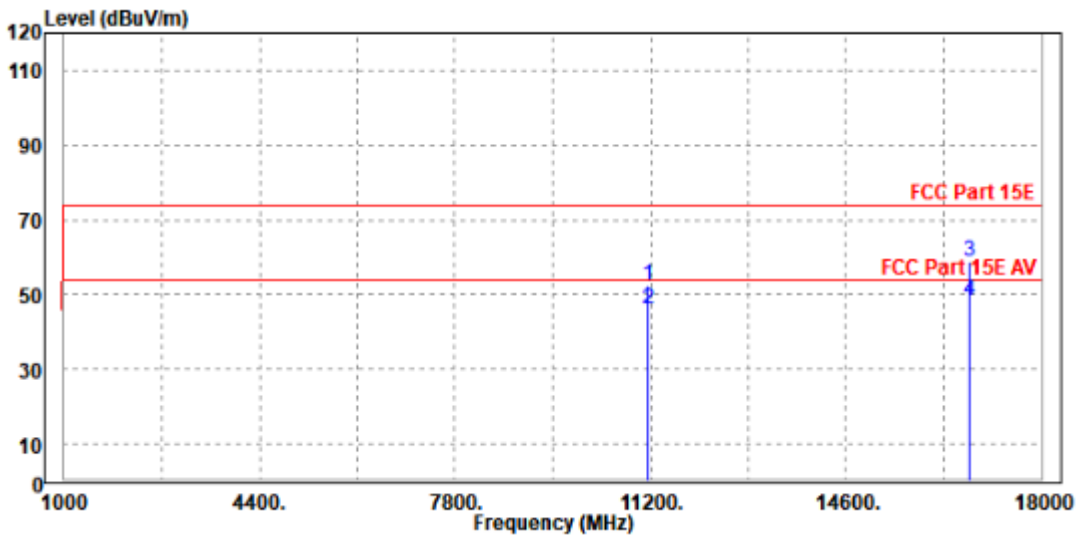



ANTENNA POLARITY & TEST DISTANCE: VERTICAL AT 3 M

	Freq	Level	Read Level	Limit Line	Over Limit	Factor	Remark	Pol/Phase
	MHz	dBuV/m	dBuV	dBuV/m	dB	dB/m		
1	11160.000	53.65	44.63	74.00	-20.35	9.02	Peak	Vertical
2	11160.000	46.62	37.60	54.00	-7.38	9.02	Average	Vertical
3	PK16742.000	58.60	41.58	74.00	-15.40	17.02	Peak	Vertical
4	PP16742.000	48.95	31.93	54.00	-5.05	17.02	Average	Vertical

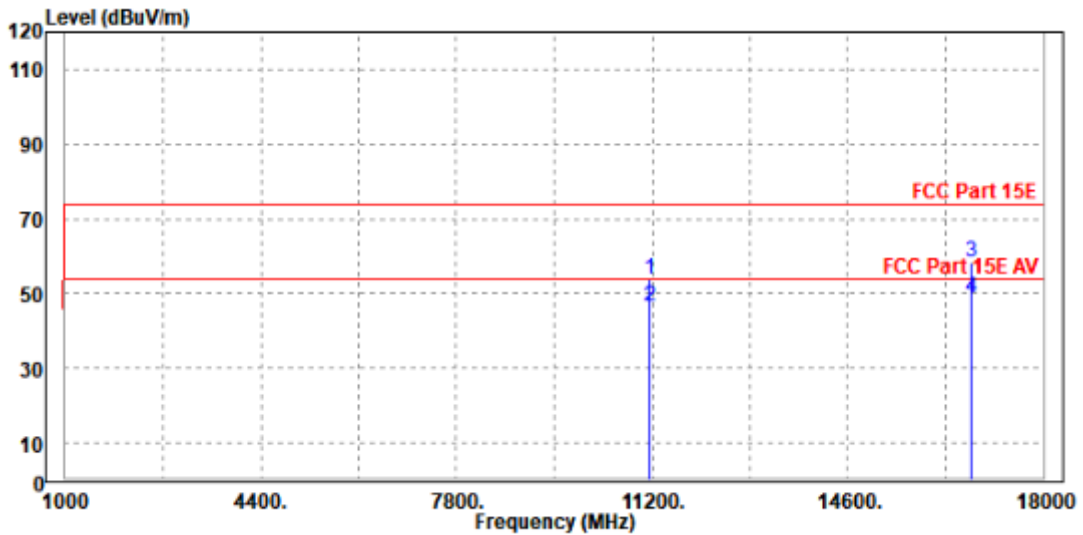

REMARKS:

1. Emission Level = Read Level+ Antenna Factor + Cable Loss- Preamp Factor
Margin value = Emission level – Limit value.
2. 5500MHz: Fundamental frequency.
3. For frequency above 18GHz, the emission was tested 20db below the limit so the data not recorded in the sheet.



Band 4:

802.11a

CHANNEL	TX Channel 149	DETECTOR FUNCTION	Peak (PK)
FREQUENCY RANGE	1GHz ~ 40GHz		Average (AV)

ANTENNA POLARITY & TEST DISTANCE: HORIZONTAL AT 3 M

FREQ. (MHz)	EMISSION LEVEL (dBuV/m)	READ LEVEL (dBuV)	LIMIT (dBuV/m)	MARGIN (dB)	ANTENNA FACTOR (dB /m)	CABLE LOSS (dB)	PREAMP FACTOR (dB)	ANTENNA HEIGHT (cm)	TABLE ANGLE (Degree)	REMARK
5745	101.31	101.51	74	27.31	34.84	11.65	46.69	100	190	Peak
5745	95.68	95.88	54	41.68	34.84	11.65	46.69	100	190	Average

ANTENNA POLARITY & TEST DISTANCE: VERTICAL AT 3 M

FREQ. (MHz)	EMISSION LEVEL (dBuV/m)	READ LEVEL (dBuV)	LIMIT (dBuV/m)	MARGIN (dB)	ANTENNA FACTOR (dB /m)	CABLE LOSS (dB)	PREAMP FACTOR (dB)	ANTENNA HEIGHT (cm)	TABLE ANGLE (Degree)	REMARK
5745	95.84	95.79	74	21.84	35.09	11.65	46.69	100	270	Peak
5745	90.46	90.41	54	36.46	35.09	11.65	46.69	100	270	Average

REMARKS:

- Emission Level = Read Level+ Antenna Factor + Cable Loss- Preamp Factor
Margin value = Emission level – Limit value.
- 5745MHz: Fundamental frequency.



Oobe Data

802.11a

ANTENNA POLARITY & TEST DISTANCE: HORIZONTAL AT 3 M										
FREQ. (MHz)	EMISSION LEVEL (dBuV/m)	READ LEVEL (dBuV)	LIMIT (dBuV/m)	MARGIN (dB)	ANTENNA FACTOR (dB /m)	CABLE LOSS (dB)	PREAMP FACTOR (dB)	ANTENNA HEIGHT (cm)	TABLE ANGLE (Degree)	REMARK
5623.15	56.75	57.17	68.2	-11.45	34.62	11.61	46.65	100	360	Peak
5939.975	58.28	58.1	68.2	-9.92	35.19	11.73	46.74	100	360	Peak
ANTENNA POLARITY & TEST DISTANCE: VERTICAL AT 3 M										
FREQ. (MHz)	EMISSION LEVEL (dBuV/m)	READ LEVEL (dBuV)	LIMIT (dBuV/m)	MARGIN (dB)	ANTENNA FACTOR (dB /m)	CABLE LOSS (dB)	PREAMP FACTOR (dB)	ANTENNA HEIGHT (cm)	TABLE ANGLE (Degree)	REMARK
5606.05	57.72	57.9	68.2	-10.48	34.87	11.6	46.65	100	0	Peak
6015.5	58	57.48	68.2	-10.2	35.51	11.77	46.76	100	0	Peak

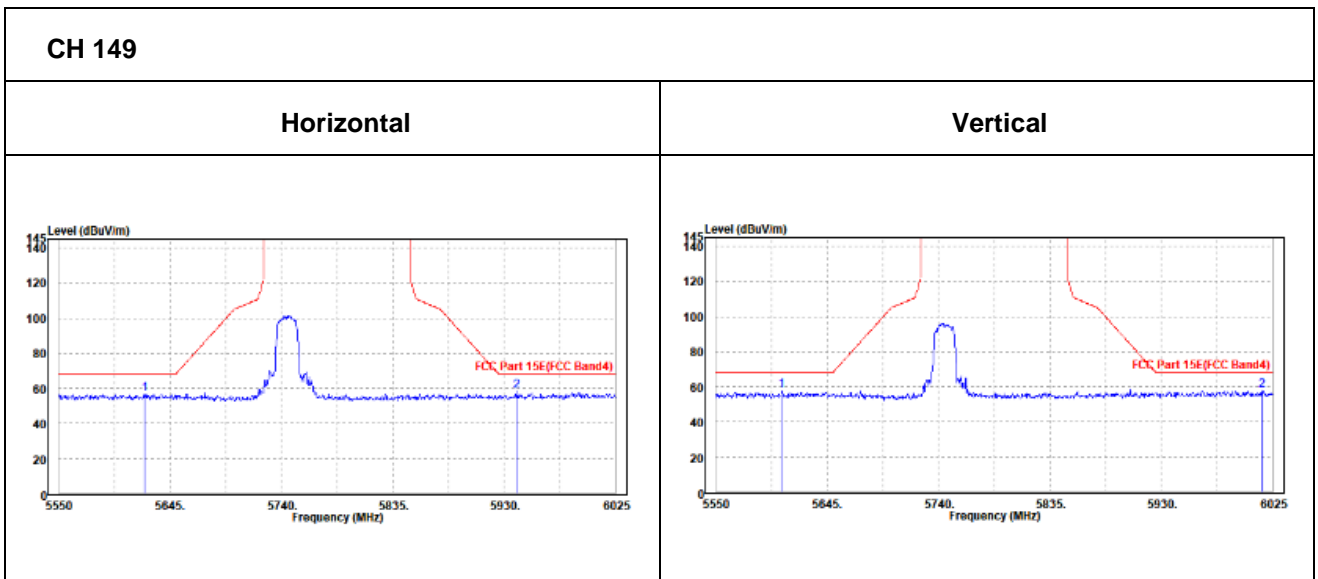



CHANNEL	TX Channel 157	DETECTOR FUNCTION	Peak (PK)
FREQUENCY RANGE	1GHz ~ 40GHz		Average (AV)

ANTENNA POLARITY & TEST DISTANCE: HORIZONTAL AT 3 M

FREQ. (MHz)	EMISSION LEVEL (dBuV/m)	READ LEVEL (dBuV)	LIMIT (dBuV/m)	MARGIN (dB)	ANTENNA FACTOR (dB /m)	CABLE LOSS (dB)	PREAMP FACTOR (dB)	ANTENNA HEIGHT (cm)	TABLE ANGLE (Degree)	REMARK
5785	101.64	101.76	74	27.64	34.91	11.67	46.7	100	190	Peak
5785	95.58	95.7	54	41.58	34.91	11.67	46.7	100	190	Average

ANTENNA POLARITY & TEST DISTANCE: VERTICAL AT 3 M

FREQ. (MHz)	EMISSION LEVEL (dBuV/m)	READ LEVEL (dBuV)	LIMIT (dBuV/m)	MARGIN (dB)	ANTENNA FACTOR (dB /m)	CABLE LOSS (dB)	PREAMP FACTOR (dB)	ANTENNA HEIGHT (cm)	TABLE ANGLE (Degree)	REMARK
5785	96.41	96.28	74	22.41	35.16	11.67	46.7	100	270	Peak
5785	91.69	91.56	54	37.69	35.16	11.67	46.7	100	270	Average

REMARKS:

- Emission Level = Read Level+ Antenna Factor + Cable Loss- Preamp Factor
Margin value = Emission level – Limit value.
- 5785MHz: Fundamental frequency.



Oobe Data

802.11a

ANTENNA POLARITY & TEST DISTANCE: HORIZONTAL AT 3 M										
FREQ. (MHz)	EMISSION LEVEL (dBuV/m)	READ LEVEL (dBuV)	LIMIT (dBuV/m)	MARGIN (dB)	ANTENNA FACTOR (dB /m)	CABLE LOSS (dB)	PREAMP FACTOR (dB)	ANTENNA HEIGHT (cm)	TABLE ANGLE (Degree)	REMARK
5573.75	57.22	57.74	68.2	-10.98	34.53	11.59	46.64	100	0	Peak
6005.05	57.37	57.07	68.2	-10.83	35.3	11.76	46.76	100	0	Peak
ANTENNA POLARITY & TEST DISTANCE: VERTICAL AT 3 M										
FREQ. (MHz)	EMISSION LEVEL (dBuV/m)	READ LEVEL (dBuV)	LIMIT (dBuV/m)	MARGIN (dB)	ANTENNA FACTOR (dB /m)	CABLE LOSS (dB)	PREAMP FACTOR (dB)	ANTENNA HEIGHT (cm)	TABLE ANGLE (Degree)	REMARK
5607.475	57.43	57.61	68.2	-10.77	34.87	11.6	46.65	100	360	Peak
5985.1	57.75	57.29	68.2	-10.45	35.48	11.74	46.76	100	360	Peak

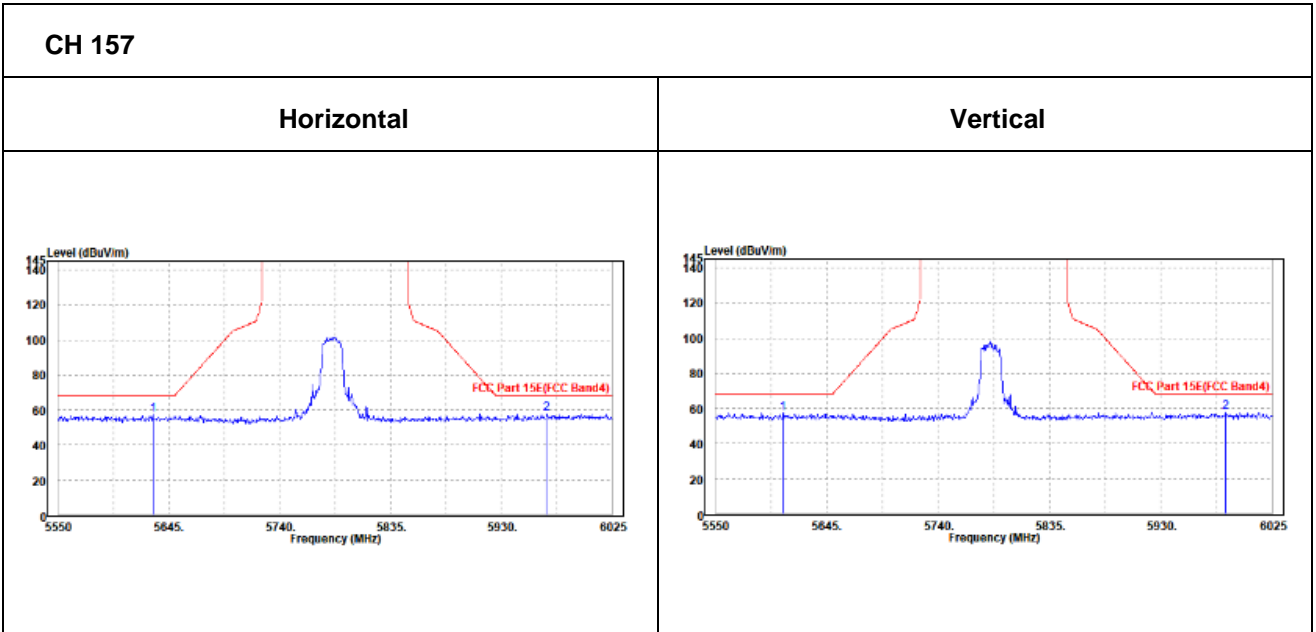



CHANNEL	TX Channel 165	DETECTOR FUNCTION	Peak (PK)
FREQUENCY RANGE	1GHz ~ 40GHz		Average (AV)

ANTENNA POLARITY & TEST DISTANCE: HORIZONTAL AT 3 M

FREQ. (MHz)	EMISSION LEVEL (dBuV/m)	READ LEVEL (dBuV)	LIMIT (dBuV/m)	MARGIN (dB)	ANTENNA FACTOR (dB /m)	CABLE LOSS (dB)	PREAMP FACTOR (dB)	ANTENNA HEIGHT (cm)	TABLE ANGLE (Degree)	REMARK
5825	102.37	102.41	74	28.37	34.99	11.68	46.71	100	190	Peak
5825	95.7	95.74	54	41.7	34.99	11.68	46.71	100	190	Average

ANTENNA POLARITY & TEST DISTANCE: VERTICAL AT 3 M

FREQ. (MHz)	EMISSION LEVEL (dBuV/m)	READ LEVEL (dBuV)	LIMIT (dBuV/m)	MARGIN (dB)	ANTENNA FACTOR (dB /m)	CABLE LOSS (dB)	PREAMP FACTOR (dB)	ANTENNA HEIGHT (cm)	TABLE ANGLE (Degree)	REMARK
5825	97.03	96.84	74	23.03	35.22	11.68	46.71	100	255	Peak
5825	90.49	90.3	54	36.49	35.22	11.68	46.71	100	255	Average

REMARKS:

- Emission Level = Read Level+ Antenna Factor + Cable Loss- Preamp Factor
Margin value = Emission level – Limit value.
- 5825MHz: Fundamental frequency.



Oobe Data

802.11a

ANTENNA POLARITY & TEST DISTANCE: HORIZONTAL AT 3 M										
FREQ. (MHz)	EMISSION LEVEL (dBuV/m)	READ LEVEL (dBuV)	LIMIT (dBuV/m)	MARGIN (dB)	ANTENNA FACTOR (dB /m)	CABLE LOSS (dB)	PREAMP FACTOR (dB)	ANTENNA HEIGHT (cm)	TABLE ANGLE (Degree)	REMARK
5564.725	56.84	57.38	68.2	-11.36	34.52	11.58	46.64	100	360	Peak
6024.525	57.94	57.6	68.2	-10.26	35.31	11.79	46.76	100	360	Peak
ANTENNA POLARITY & TEST DISTANCE: VERTICAL AT 3 M										
FREQ. (MHz)	EMISSION LEVEL (dBuV/m)	READ LEVEL (dBuV)	LIMIT (dBuV/m)	MARGIN (dB)	ANTENNA FACTOR (dB /m)	CABLE LOSS (dB)	PREAMP FACTOR (dB)	ANTENNA HEIGHT (cm)	TABLE ANGLE (Degree)	REMARK
5618.875	56.64	56.79	68.2	-11.56	34.89	11.61	46.65	100	0	Peak
5995.55	57.85	57.37	68.2	-10.35	35.49	11.75	46.76	100	0	Peak

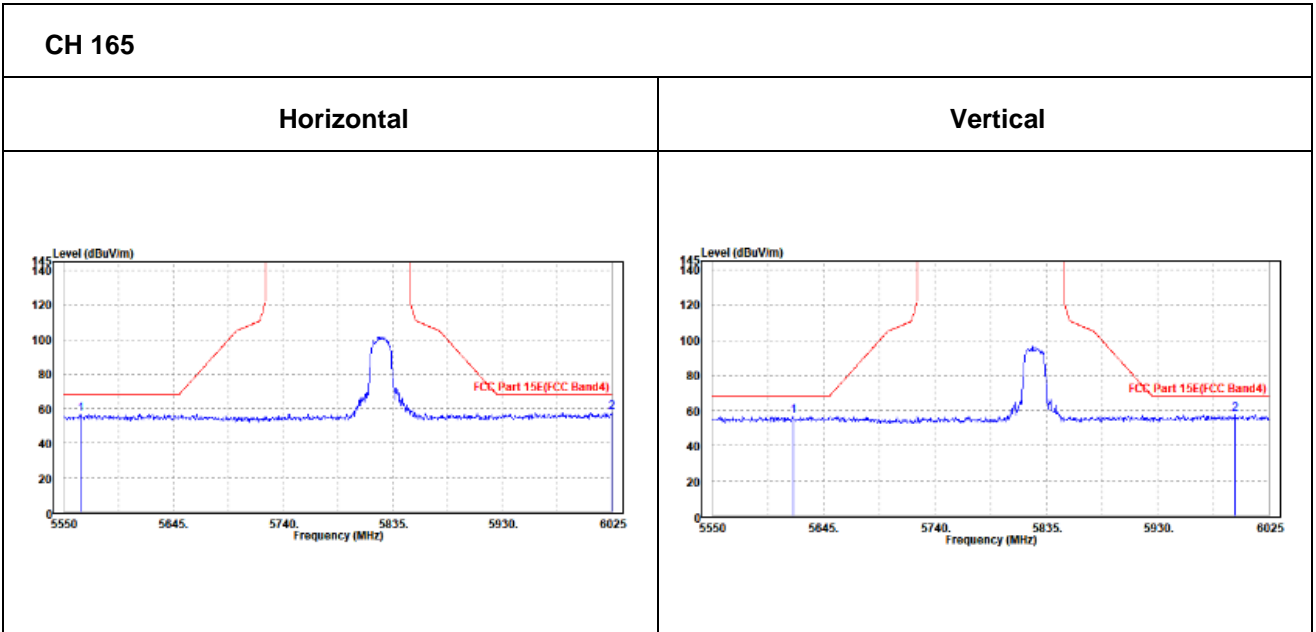



802.11n (20MHz)

CHANNEL	TX Channel 149	DETECTOR FUNCTION	Peak (PK)
FREQUENCY RANGE	1GHz ~ 40GHz		Average (AV)

ANTENNA POLARITY & TEST DISTANCE: HORIZONTAL AT 3 M

FREQ. (MHz)	EMISSION LEVEL (dBuV/m)	READ LEVEL (dBuV)	LIMIT (dBuV/m)	MARGIN (dB)	ANTENNA FACTOR (dB /m)	CABLE LOSS (dB)	PREAMP FACTOR (dB)	ANTENNA HEIGHT (cm)	TABLE ANGLE (Degree)	REMARK
5745	99.99	100.19	74	25.99	34.84	11.65	46.69	100	190	Peak
5745	94.03	94.23	54	40.03	34.84	11.65	46.69	100	190	Average

ANTENNA POLARITY & TEST DISTANCE: VERTICAL AT 3 M

FREQ. (MHz)	EMISSION LEVEL (dBuV/m)	READ LEVEL (dBuV)	LIMIT (dBuV/m)	MARGIN (dB)	ANTENNA FACTOR (dB /m)	CABLE LOSS (dB)	PREAMP FACTOR (dB)	ANTENNA HEIGHT (cm)	TABLE ANGLE (Degree)	REMARK
5745	94.22	94.17	74	20.22	35.09	11.65	46.69	100	270	Peak
5745	88.1	88.05	54	34.1	35.09	11.65	46.69	100	270	Average

REMARKS:

- Emission Level = Read Level+ Antenna Factor + Cable Loss- Preamp Factor
Margin value = Emission level – Limit value.
- 5745MHz: Fundamental frequency.



Oobe Data

802.11n (20MHz)

ANTENNA POLARITY & TEST DISTANCE: HORIZONTAL AT 3 M										
FREQ. (MHz)	EMISSION LEVEL (dBuV/m)	READ LEVEL (dBuV)	LIMIT (dBuV/m)	MARGIN (dB)	ANTENNA FACTOR (dB /m)	CABLE LOSS (dB)	PREAMP FACTOR (dB)	ANTENNA HEIGHT (cm)	TABLE ANGLE (Degree)	REMARK
5558.075	57.45	58.01	68.2	-10.75	34.5	11.58	46.64	100	0	Peak
6003.15	57.06	56.77	68.2	-11.14	35.3	11.75	46.76	100	0	Peak
ANTENNA POLARITY & TEST DISTANCE: VERTICAL AT 3 M										
FREQ. (MHz)	EMISSION LEVEL (dBuV/m)	READ LEVEL (dBuV)	LIMIT (dBuV/m)	MARGIN (dB)	ANTENNA FACTOR (dB /m)	CABLE LOSS (dB)	PREAMP FACTOR (dB)	ANTENNA HEIGHT (cm)	TABLE ANGLE (Degree)	REMARK
5591.8	57.69	57.9	68.2	-10.51	34.85	11.59	46.65	100	360	Peak
5987	58.18	57.71	68.2	-10.02	35.48	11.75	46.76	100	360	Peak

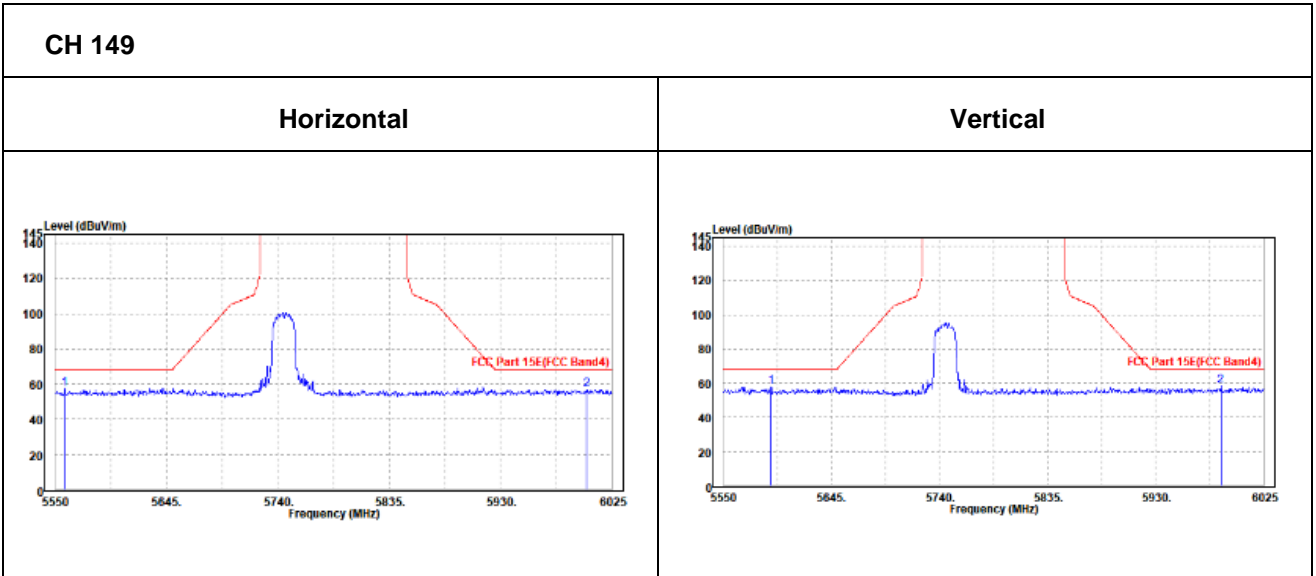



CHANNEL	TX Channel 157	DETECTOR FUNCTION	Peak (PK)
FREQUENCY RANGE	1GHz ~ 40GHz		Average (AV)

ANTENNA POLARITY & TEST DISTANCE: HORIZONTAL AT 3 M

FREQ. (MHz)	EMISSION LEVEL (dBuV/m)	READ LEVEL (dBuV)	LIMIT (dBuV/m)	MARGIN (dB)	ANTENNA FACTOR (dB /m)	CABLE LOSS (dB)	PREAMP FACTOR (dB)	ANTENNA HEIGHT (cm)	TABLE ANGLE (Degree)	REMARK
5785	100.26	100.38	74	26.26	34.91	11.67	46.7	100	190	Peak
5785	93.88	94	54	39.88	34.91	11.67	46.7	100	190	Average

ANTENNA POLARITY & TEST DISTANCE: VERTICAL AT 3 M

FREQ. (MHz)	EMISSION LEVEL (dBuV/m)	READ LEVEL (dBuV)	LIMIT (dBuV/m)	MARGIN (dB)	ANTENNA FACTOR (dB /m)	CABLE LOSS (dB)	PREAMP FACTOR (dB)	ANTENNA HEIGHT (cm)	TABLE ANGLE (Degree)	REMARK
5785	95.46	95.33	74	21.46	35.16	11.67	46.7	100	265	Peak
5785	90.9	90.77	54	36.9	35.16	11.67	46.7	100	265	Average

REMARKS:

- Emission Level = Read Level+ Antenna Factor + Cable Loss- Preamp Factor
Margin value = Emission level – Limit value.
- 5785MHz: Fundamental frequency.



Oobe Data

802.11n (20MHz)

ANTENNA POLARITY & TEST DISTANCE: HORIZONTAL AT 3 M										
FREQ. (MHz)	EMISSION LEVEL (dBuV/m)	READ LEVEL (dBuV)	LIMIT (dBuV /m)	MARGIN (dB)	ANTENNA FACTOR (dB /m)	CABLE LOSS (dB)	PREAMP FACTOR (dB)	ANTENNA HEIGHT (cm)	TABLE ANGLE (Degree)	REMARK
5612.225	56.91	57.36	68.2	-11.29	34.6	11.6	46.65	100	360	Peak
5966.575	58.78	58.55	68.2	-9.42	35.24	11.74	46.75	100	360	Peak
ANTENNA POLARITY & TEST DISTANCE: VERTICAL AT 3 M										
FREQ. (MHz)	EMISSION LEVEL (dBuV/m)	READ LEVEL (dBuV)	LIMIT (dBuV /m)	MARGIN (dB)	ANTENNA FACTOR (dB /m)	CABLE LOSS (dB)	PREAMP FACTOR (dB)	ANTENNA HEIGHT (cm)	TABLE ANGLE (Degree)	REMARK
5630.75	57.84	57.98	68.2	-10.36	34.91	11.61	46.66	100	0	Peak
5988.9	58.09	57.62	68.2	-10.11	35.48	11.75	46.76	100	0	Peak

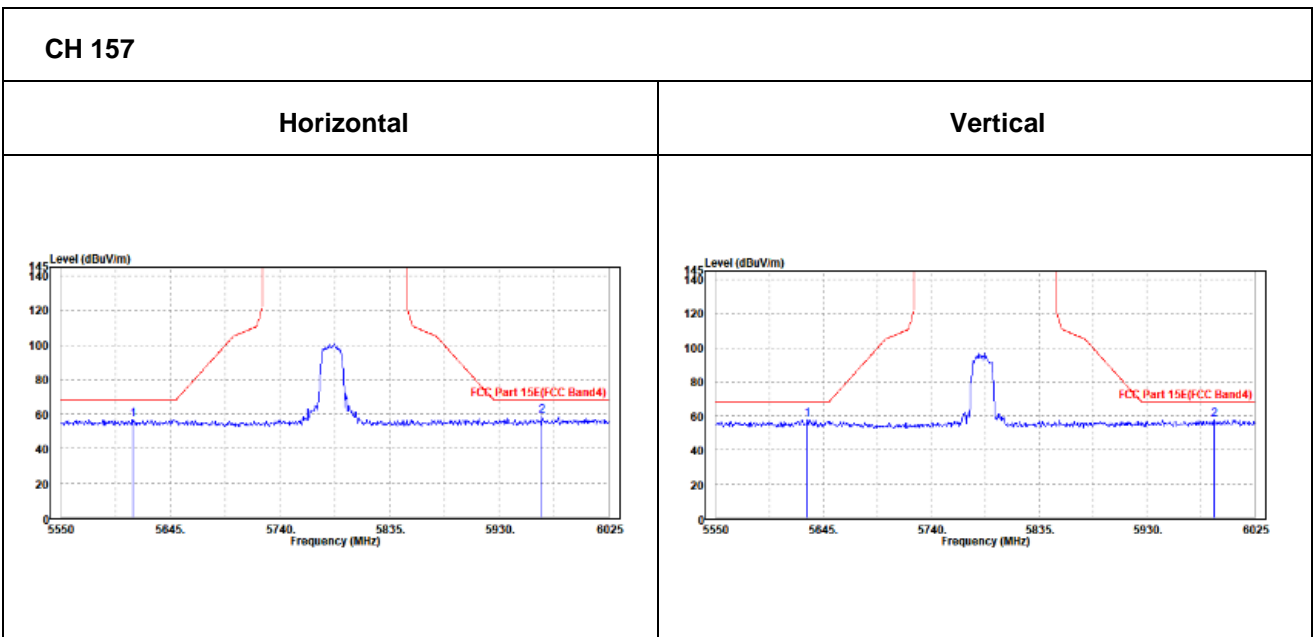



CHANNEL	TX Channel 165	DETECTOR FUNCTION	Peak (PK)
FREQUENCY RANGE	1GHz ~ 40GHz		Average (AV)

ANTENNA POLARITY & TEST DISTANCE: HORIZONTAL AT 3 M

FREQ. (MHz)	EMISSION LEVEL (dBuV/m)	READ LEVEL (dBuV)	LIMIT (dBuV/m)	MARGIN (dB)	ANTENNA FACTOR (dB /m)	CABLE LOSS (dB)	PREAMP FACTOR (dB)	ANTENNA HEIGHT (cm)	TABLE ANGLE (Degree)	REMARK
5825	101.29	101.33	74	27.29	34.99	11.68	46.71	100	190	Peak
5825	95.4	95.44	54	41.4	34.99	11.68	46.71	100	190	Average

ANTENNA POLARITY & TEST DISTANCE: VERTICAL AT 3 M

FREQ. (MHz)	EMISSION LEVEL (dBuV/m)	READ LEVEL (dBuV)	LIMIT (dBuV/m)	MARGIN (dB)	ANTENNA FACTOR (dB /m)	CABLE LOSS (dB)	PREAMP FACTOR (dB)	ANTENNA HEIGHT (cm)	TABLE ANGLE (Degree)	REMARK
5825	96.28	96.09	74	22.28	35.22	11.68	46.71	100	260	Peak
5825	88.72	88.53	54	34.72	35.22	11.68	46.71	100	260	Average

REMARKS:

- Emission Level = Read Level+ Antenna Factor + Cable Loss- Preamp Factor
Margin value = Emission level – Limit value.
- 5825MHz: Fundamental frequency.



Oobe Data

802.11n (20MHz)

ANTENNA POLARITY & TEST DISTANCE: HORIZONTAL AT 3 M										
FREQ. (MHz)	EMISSION LEVEL (dBuV/m)	READ LEVEL (dBuV)	LIMIT (dBuV/m)	MARGIN (dB)	ANTENNA FACTOR (dB /m)	CABLE LOSS (dB)	PREAMP FACTOR (dB)	ANTENNA HEIGHT (cm)	TABLE ANGLE (Degree)	REMARK
5556.65	57.16	57.72	68.2	-11.04	34.5	11.58	46.64	100	0	Peak
6021.2	57.96	57.63	68.2	-10.24	35.31	11.78	46.76	100	0	Peak
ANTENNA POLARITY & TEST DISTANCE: VERTICAL AT 3 M										
FREQ. (MHz)	EMISSION LEVEL (dBuV/m)	READ LEVEL (dBuV)	LIMIT (dBuV/m)	MARGIN (dB)	ANTENNA FACTOR (dB /m)	CABLE LOSS (dB)	PREAMP FACTOR (dB)	ANTENNA HEIGHT (cm)	TABLE ANGLE (Degree)	REMARK
5585.15	57.84	58.05	68.2	-10.36	34.84	11.59	46.64	100	360	Peak
6006.95	57.76	57.26	68.2	-10.44	35.5	11.76	46.76	100	360	Peak

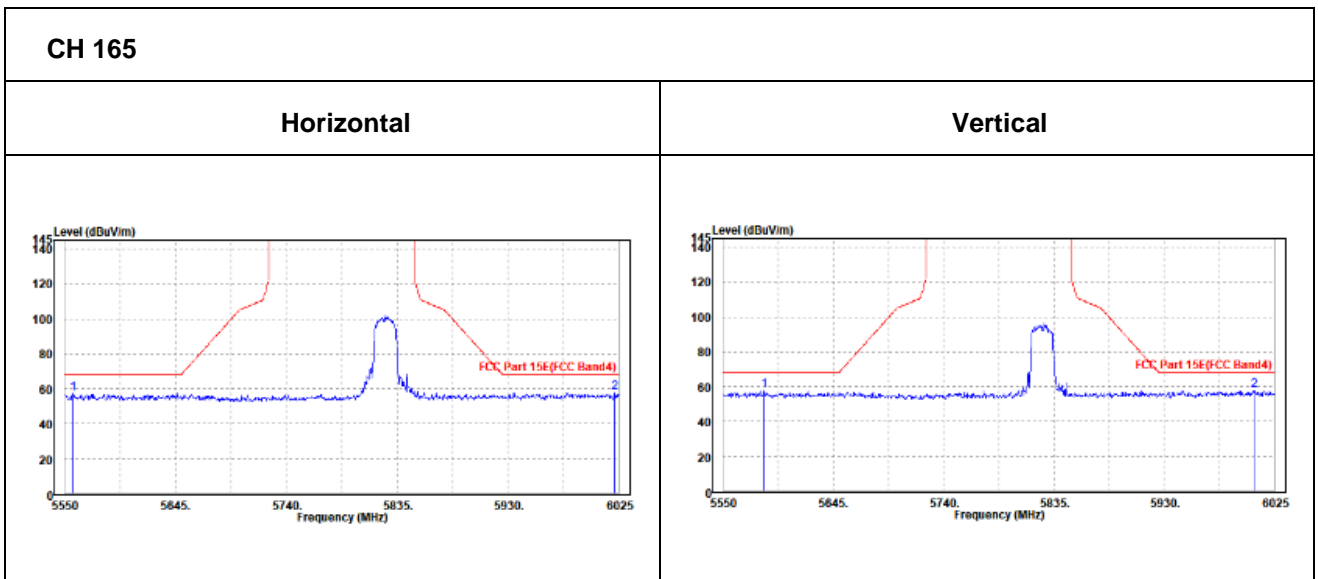



802.11n (40MHz)

CHANNEL	TX Channel 151	DETECTOR FUNCTION	Peak (PK)
FREQUENCY RANGE	1GHz ~ 40GHz		Average (AV)

ANTENNA POLARITY & TEST DISTANCE: HORIZONTAL AT 3 M

FREQ. (MHz)	EMISSION LEVEL (dBuV/m)	READ LEVEL (dBuV)	LIMIT (dBuV/m)	MARGIN (dB)	ANTENNA FACTOR (dB /m)	CABLE LOSS (dB)	PREAMP FACTOR (dB)	ANTENNA HEIGHT (cm)	TABLE ANGLE (Degree)	REMARK
5755	95.39	95.56	74	21.39	34.86	11.66	46.69	100	190	Peak
5755	91.01	91.18	54	37.01	34.86	11.66	46.69	100	190	Average

ANTENNA POLARITY & TEST DISTANCE: VERTICAL AT 3 M

FREQ. (MHz)	EMISSION LEVEL (dBuV/m)	READ LEVEL (dBuV)	LIMIT (dBuV/m)	MARGIN (dB)	ANTENNA FACTOR (dB /m)	CABLE LOSS (dB)	PREAMP FACTOR (dB)	ANTENNA HEIGHT (cm)	TABLE ANGLE (Degree)	REMARK
5755	90.16	90.08	74	16.16	35.11	11.66	46.69	100	270	Peak
5755	85.16	85.08	54	31.16	35.11	11.66	46.69	100	270	Average

REMARKS:

- Emission Level = Read Level+ Antenna Factor + Cable Loss- Preamp Factor
Margin value = Emission level – Limit value.
- 5755MHz: Fundamental frequency.



Oobe Data

802.11n (40MHz)

ANTENNA POLARITY & TEST DISTANCE: HORIZONTAL AT 3 M										
FREQ. (MHz)	EMISSION LEVEL (dBuV/m)	READ LEVEL (dBuV)	LIMIT (dBuV/m)	MARGIN (dB)	ANTENNA FACTOR (dB /m)	CABLE LOSS (dB)	PREAMP FACTOR (dB)	ANTENNA HEIGHT (cm)	TABLE ANGLE (Degree)	REMARK
5592.75	57	57.48	68.2	-11.2	34.57	11.6	46.65	100	360	Peak
5998.875	57.64	57.35	68.2	-10.56	35.3	11.75	46.76	100	360	Peak
ANTENNA POLARITY & TEST DISTANCE: VERTICAL AT 3 M										
FREQ. (MHz)	EMISSION LEVEL (dBuV/m)	READ LEVEL (dBuV)	LIMIT (dBuV/m)	MARGIN (dB)	ANTENNA FACTOR (dB /m)	CABLE LOSS (dB)	PREAMP FACTOR (dB)	ANTENNA HEIGHT (cm)	TABLE ANGLE (Degree)	REMARK
5602.25	58.61	58.8	68.2	-9.59	34.86	11.6	46.65	100	0	Peak
5976.075	57.93	57.48	68.2	-10.27	35.46	11.74	46.75	100	0	Peak

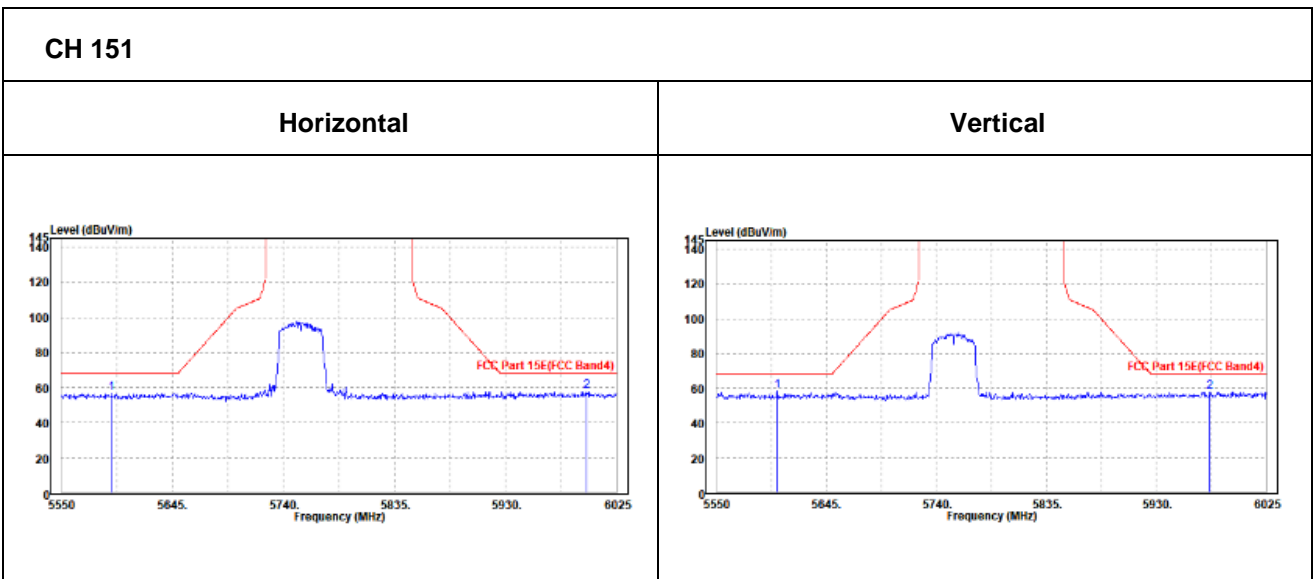



CHANNEL	TX Channel 159	DETECTOR FUNCTION	Peak (PK)
FREQUENCY RANGE	1GHz ~ 40GHz		Average (AV)

ANTENNA POLARITY & TEST DISTANCE: HORIZONTAL AT 3 M										
FREQ. (MHz)	EMISSION LEVEL (dBuV/m)	READ LEVEL (dBuV)	LIMIT (dBuV/m)	MARGIN (dB)	ANTENNA FACTOR (dB /m)	CABLE LOSS (dB)	PREAMP FACTOR (dB)	ANTENNA HEIGHT (cm)	TABLE ANGLE (Degree)	REMARK
5795	96.7	96.8	74	22.7	34.93	11.67	46.7	100	190	Peak
5795	91.71	91.81	54	37.71	34.93	11.67	46.7	100	190	Average
ANTENNA POLARITY & TEST DISTANCE: VERTICAL AT 3 M										
FREQ. (MHz)	EMISSION LEVEL (dBuV/m)	READ LEVEL (dBuV)	LIMIT (dBuV/m)	MARGIN (dB)	ANTENNA FACTOR (dB /m)	CABLE LOSS (dB)	PREAMP FACTOR (dB)	ANTENNA HEIGHT (cm)	TABLE ANGLE (Degree)	REMARK
5795	90.81	90.67	74	16.81	35.17	11.67	46.7	100	265	Peak
5795	85.66	85.52	54	31.66	35.17	11.67	46.7	100	265	Average

REMARKS:

- Emission Level = Read Level+ Antenna Factor + Cable Loss- Preamp Factor
Margin value = Emission level – Limit value.
- 5795MHz: Fundamental frequency.



OOBE DATA

802.11n (40MHZ)

ANTENNA POLARITY & TEST DISTANCE: HORIZONTAL AT 3 M										
FREQ. (MHz)	EMISSION LEVEL (dBuV/m)	READ LEVEL (dBuV)	LIMIT (dBuV/m)	MARGIN (dB)	ANTENNA FACTOR (dB /m)	CABLE LOSS (dB)	PREAMP FACTOR (dB)	ANTENNA HEIGHT (cm)	TABLE ANGLE (Degree)	REMARK
5613.65	57.15	57.6	68.2	-11.05	34.6	11.6	46.65	100	0	Peak
5982.725	57.98	57.73	68.2	-10.22	35.27	11.74	46.76	100	0	Peak
ANTENNA POLARITY & TEST DISTANCE: VERTICAL AT 3 M										
FREQ. (MHz)	EMISSION LEVEL (dBuV/m)	READ LEVEL (dBuV)	LIMIT (dBuV/m)	MARGIN (dB)	ANTENNA FACTOR (dB /m)	CABLE LOSS (dB)	PREAMP FACTOR (dB)	ANTENNA HEIGHT (cm)	TABLE ANGLE (Degree)	REMARK
5637.875	57.03	57.16	68.2	-11.17	34.92	11.61	46.66	100	360	Peak
6016.925	58.09	57.57	68.2	-10.11	35.51	11.77	46.76	100	360	Peak

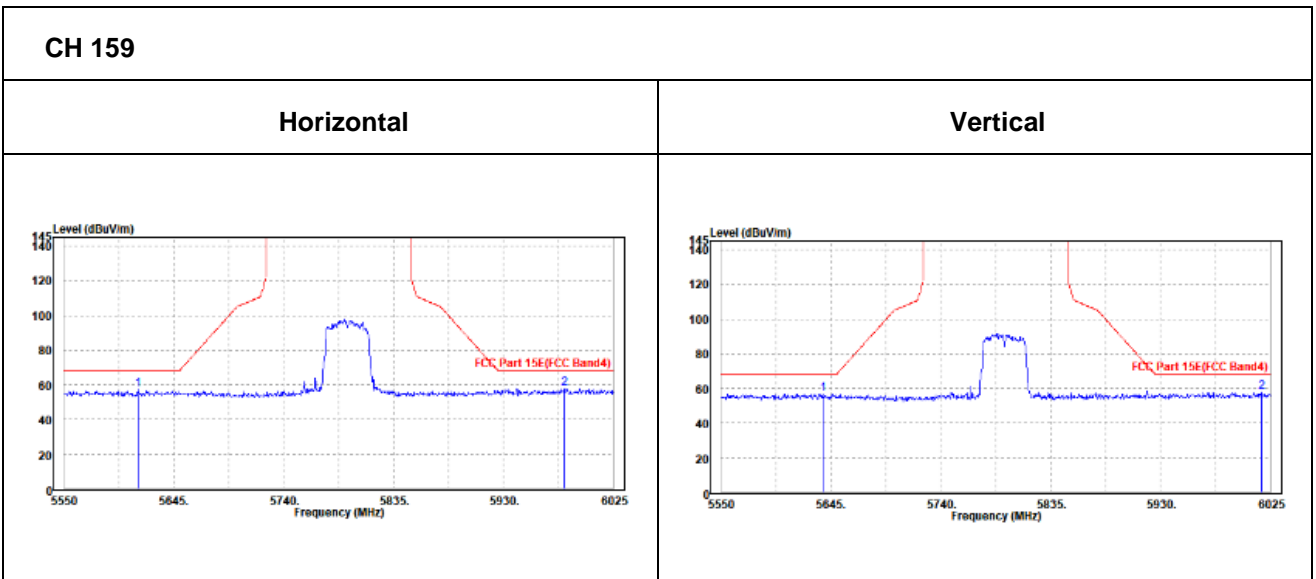



802.11ac (20MHz)

CHANNEL	TX Channel 149	DETECTOR FUNCTION	Peak (PK)
FREQUENCY RANGE	1GHz ~ 40GHz		Average (AV)

ANTENNA POLARITY & TEST DISTANCE: HORIZONTAL AT 3 M										
FREQ. (MHz)	EMISSION LEVEL (dBuV/m)	READ LEVEL (dBuV)	LIMIT (dBuV/m)	MARGIN (dB)	ANTENNA FACTOR (dB /m)	CABLE LOSS (dB)	PREAMP FACTOR (dB)	ANTENNA HEIGHT (cm)	TABLE ANGLE (Degree)	REMARK
5745	100.05	100.25	74	26.05	34.84	11.65	46.69	100	190	Peak
5745	94.63	94.83	54	40.63	34.84	11.65	46.69	100	190	Average
ANTENNA POLARITY & TEST DISTANCE: VERTICAL AT 3 M										
FREQ. (MHz)	EMISSION LEVEL (dBuV/m)	READ LEVEL (dBuV)	LIMIT (dBuV/m)	MARGIN (dB)	ANTENNA FACTOR (dB /m)	CABLE LOSS (dB)	PREAMP FACTOR (dB)	ANTENNA HEIGHT (cm)	TABLE ANGLE (Degree)	REMARK
5745	95.58	95.53	74	21.58	35.09	11.65	46.69	100	270	Peak
5745	88.14	88.09	54	34.14	35.09	11.65	46.69	100	270	Average

REMARKS:

- Emission Level = Read Level+ Antenna Factor + Cable Loss- Preamp Factor
Margin value = Emission level – Limit value.
- 5745MHz: Fundamental frequency.



Oobe Data

802.11ac (20MHz)

ANTENNA POLARITY & TEST DISTANCE: HORIZONTAL AT 3 M										
FREQ. (MHz)	EMISSION LEVEL (dBuV/m)	READ LEVEL (dBuV)	LIMIT (dBuV/m)	MARGIN (dB)	ANTENNA FACTOR (dB /m)	CABLE LOSS (dB)	PREAMP FACTOR (dB)	ANTENNA HEIGHT (cm)	TABLE ANGLE (Degree)	REMARK
5618.875	57.54	57.97	68.2	-10.66	34.61	11.61	46.65	100	360	Peak
5947.1	57.46	57.28	68.2	-10.74	35.2	11.73	46.75	100	360	Peak
ANTENNA POLARITY & TEST DISTANCE: VERTICAL AT 3 M										
FREQ. (MHz)	EMISSION LEVEL (dBuV/m)	READ LEVEL (dBuV)	LIMIT (dBuV/m)	MARGIN (dB)	ANTENNA FACTOR (dB /m)	CABLE LOSS (dB)	PREAMP FACTOR (dB)	ANTENNA HEIGHT (cm)	TABLE ANGLE (Degree)	REMARK
5566.15	57.12	57.36	68.2	-11.08	34.81	11.59	46.64	100	0	Peak
5973.225	57.95	57.5	68.2	-10.25	35.46	11.74	46.75	100	0	Peak

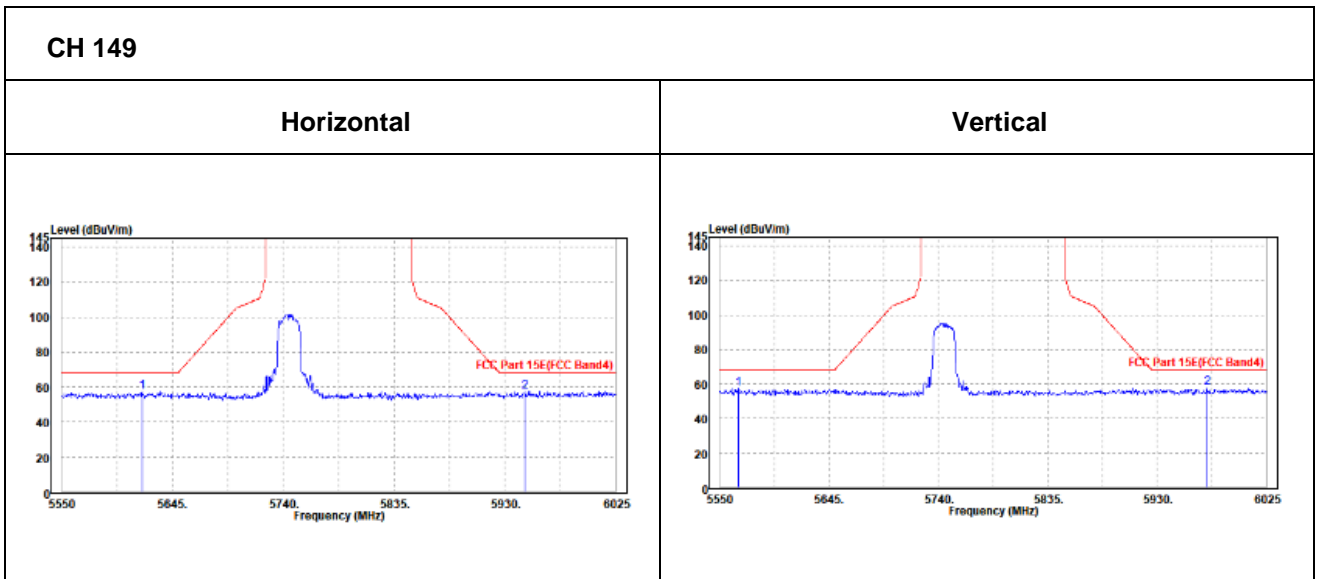



CHANNEL	TX Channel 157	DETECTOR FUNCTION	Peak (PK)
FREQUENCY RANGE	1GHz ~ 40GHz		Average (AV)

ANTENNA POLARITY & TEST DISTANCE: HORIZONTAL AT 3 M

FREQ. (MHz)	EMISSION LEVEL (dBuV/m)	READ LEVEL (dBuV)	LIMIT (dBuV/m)	MARGIN (dB)	ANTENNA FACTOR (dB /m)	CABLE LOSS (dB)	PREAMP FACTOR (dB)	ANTENNA HEIGHT (cm)	TABLE ANGLE (Degree)	REMARK
5785	100.76	100.88	74	26.76	34.91	11.67	46.7	100	190	Peak
5785	95.27	95.39	54	41.27	34.91	11.67	46.7	100	190	Average

ANTENNA POLARITY & TEST DISTANCE: VERTICAL AT 3 M

FREQ. (MHz)	EMISSION LEVEL (dBuV/m)	READ LEVEL (dBuV)	LIMIT (dBuV/m)	MARGIN (dB)	ANTENNA FACTOR (dB /m)	CABLE LOSS (dB)	PREAMP FACTOR (dB)	ANTENNA HEIGHT (cm)	TABLE ANGLE (Degree)	REMARK
5785	96.29	96.16	74	22.29	35.16	11.67	46.7	100	270	Peak
5785	90.11	89.98	54	36.11	35.16	11.67	46.7	100	270	Average

REMARKS:

- Emission Level = Read Level+ Antenna Factor + Cable Loss- Preamp Factor
Margin value = Emission level – Limit value.
- 5785MHz: Fundamental frequency.



Oobe Data

802.11ac (20MHz)

ANTENNA POLARITY & TEST DISTANCE: HORIZONTAL AT 3 M										
FREQ. (MHz)	EMISSION LEVEL (dBuV/m)	READ LEVEL (dBuV)	LIMIT (dBuV /m)	MARGIN (dB)	ANTENNA FACTOR (dB /m)	CABLE LOSS (dB)	PREAMP FACTOR (dB)	ANTENNA HEIGHT (cm)	TABLE ANGLE (Degree)	REMARK
5573.75	57.22	57.74	68.2	-10.98	34.53	11.59	46.64	100	0	Peak
6005.05	57.37	57.07	68.2	-10.83	35.3	11.76	46.76	100	0	Peak
ANTENNA POLARITY & TEST DISTANCE: VERTICAL AT 3 M										
FREQ. (MHz)	EMISSION LEVEL (dBuV/m)	READ LEVEL (dBuV)	LIMIT (dBuV /m)	MARGIN (dB)	ANTENNA FACTOR (dB /m)	CABLE LOSS (dB)	PREAMP FACTOR (dB)	ANTENNA HEIGHT (cm)	TABLE ANGLE (Degree)	REMARK
5607	57.65	57.83	68.2	-10.55	34.87	11.6	46.65	100	360	Peak
5992.225	57.75	57.27	68.2	-10.45	35.49	11.75	46.76	100	360	Peak

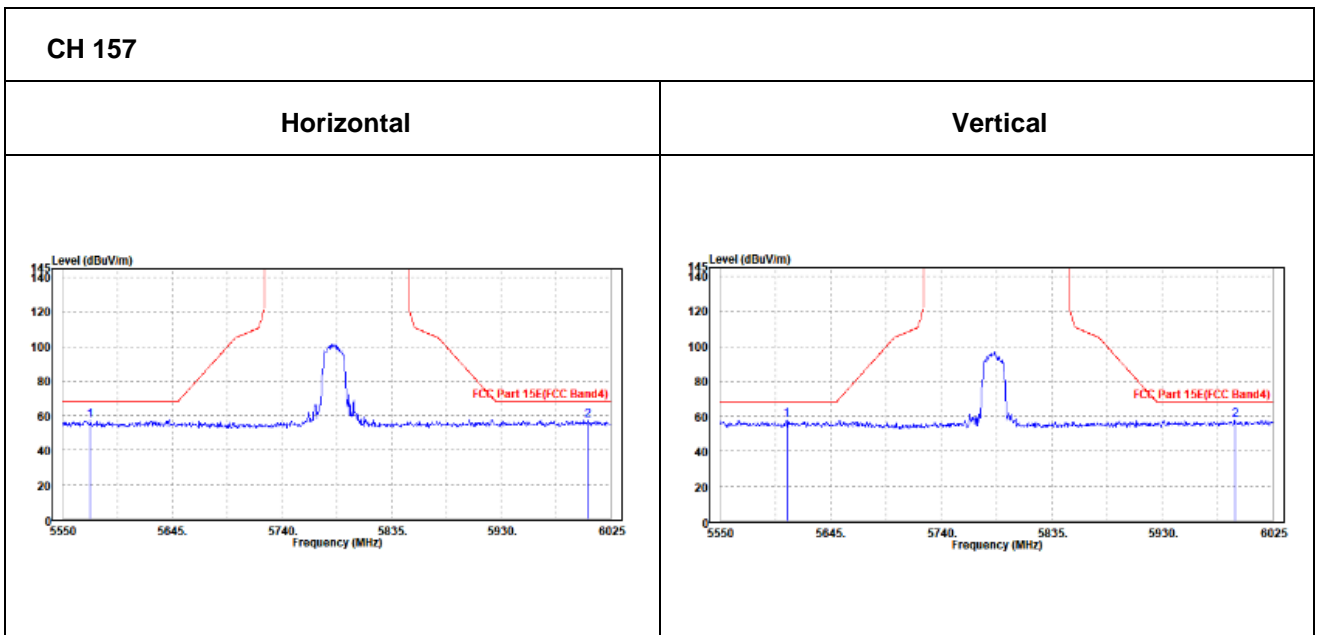



CHANNEL	TX Channel 165	DETECTOR FUNCTION	Peak (PK)
FREQUENCY RANGE	1GHz ~ 40GHz		Average (AV)

ANTENNA POLARITY & TEST DISTANCE: HORIZONTAL AT 3 M										
FREQ. (MHz)	EMISSION LEVEL (dBuV/m)	READ LEVEL (dBuV)	LIMIT (dBuV/m)	MARGIN (dB)	ANTENNA FACTOR (dB /m)	CABLE LOSS (dB)	PREAMP FACTOR (dB)	ANTENNA HEIGHT (cm)	TABLE ANGLE (Degree)	REMARK
5825	101.64	101.68	74	27.64	34.99	11.68	46.71	100	190	Peak
5825	95.37	95.41	54	41.37	34.99	11.68	46.71	100	190	Average
ANTENNA POLARITY & TEST DISTANCE: VERTICAL AT 3 M										
FREQ. (MHz)	EMISSION LEVEL (dBuV/m)	READ LEVEL (dBuV)	LIMIT (dBuV/m)	MARGIN (dB)	ANTENNA FACTOR (dB /m)	CABLE LOSS (dB)	PREAMP FACTOR (dB)	ANTENNA HEIGHT (cm)	TABLE ANGLE (Degree)	REMARK
5825	95.65	95.46	74	21.65	35.22	11.68	46.71	100	265	Peak
5825	89.44	89.25	54	35.44	35.22	11.68	46.71	100	265	Average

REMARKS:

1. Emission Level = Read Level+ Antenna Factor + Cable Loss- Preamp Factor
Margin value = Emission level – Limit value.
2. 5825MHz: Fundamental frequency.



OBE DATA

802.11ac (20MHZ)

ANTENNA POLARITY & TEST DISTANCE: HORIZONTAL AT 3 M										
FREQ. (MHz)	EMISSION LEVEL (dBuV/m)	READ LEVEL (dBuV)	LIMIT (dBuV/m)	MARGIN (dB)	ANTENNA FACTOR (dB /m)	CABLE LOSS (dB)	PREAMP FACTOR (dB)	ANTENNA HEIGHT (cm)	TABLE ANGLE (Degree)	REMARK
5615.075	56.74	57.18	68.2	-11.46	34.61	11.6	46.65	100	360	Peak
6010.75	58.05	57.73	68.2	-10.15	35.31	11.77	46.76	100	360	Peak
ANTENNA POLARITY & TEST DISTANCE: VERTICAL AT 3 M										
FREQ. (MHz)	EMISSION LEVEL (dBuV/m)	READ LEVEL (dBuV)	LIMIT (dBuV/m)	MARGIN (dB)	ANTENNA FACTOR (dB /m)	CABLE LOSS (dB)	PREAMP FACTOR (dB)	ANTENNA HEIGHT (cm)	TABLE ANGLE (Degree)	REMARK
5552.85	57.7	57.97	68.2	-10.5	34.78	11.58	46.63	100	0	Peak
5945.675	58.7	58.3	68.2	-9.5	35.41	11.73	46.74	100	0	Peak

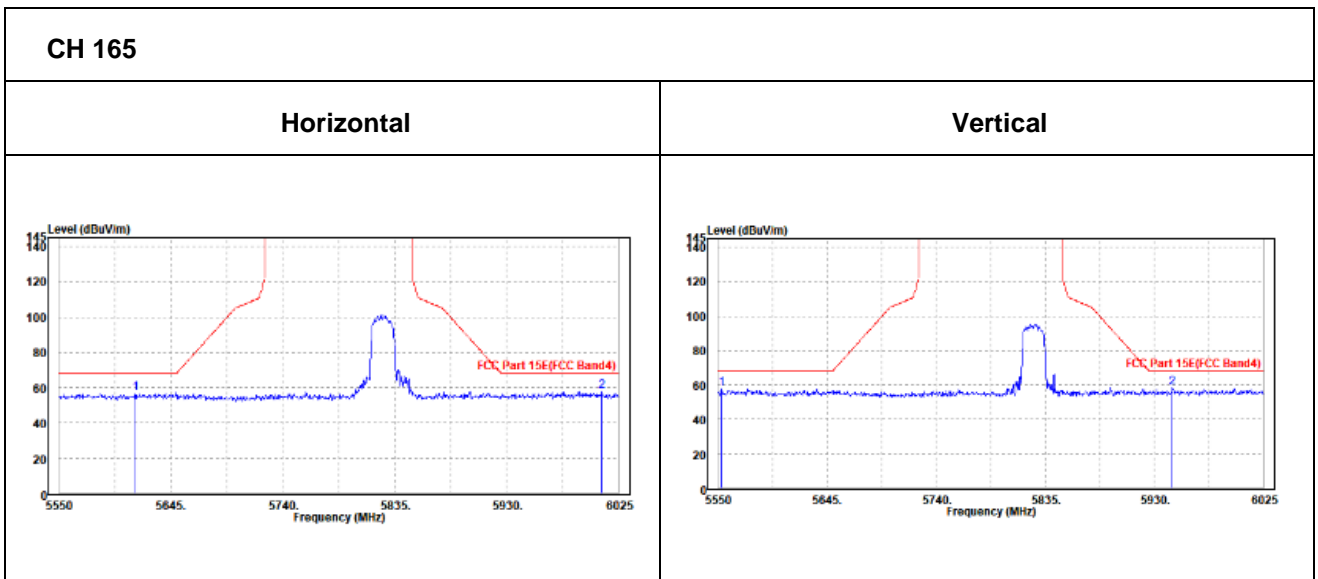



802.11ac (40MHz)

CHANNEL	TX Channel 151	DETECTOR FUNCTION	Peak (PK)
FREQUENCY RANGE	1GHz ~ 40GHz		Average (AV)

ANTENNA POLARITY & TEST DISTANCE: HORIZONTAL AT 3 M										
FREQ. (MHz)	EMISSION LEVEL (dBuV/m)	READ LEVEL (dBuV)	LIMIT (dBuV/m)	MARGIN (dB)	ANTENNA FACTOR (dB /m)	CABLE LOSS (dB)	PREAMP FACTOR (dB)	ANTENNA HEIGHT (cm)	TABLE ANGLE (Degree)	REMARK
5755	95.55	95.72	74	21.55	34.86	11.66	46.69	100	190	Peak
5755	89.83	90	54	35.83	34.86	11.66	46.69	100	190	Average
ANTENNA POLARITY & TEST DISTANCE: VERTICAL AT 3 M										
FREQ. (MHz)	EMISSION LEVEL (dBuV/m)	READ LEVEL (dBuV)	LIMIT (dBuV/m)	MARGIN (dB)	ANTENNA FACTOR (dB /m)	CABLE LOSS (dB)	PREAMP FACTOR (dB)	ANTENNA HEIGHT (cm)	TABLE ANGLE (Degree)	REMARK
5755	90.21	90.13	74	16.21	35.11	11.66	46.69	100	270	Peak
5755	85.39	85.31	54	31.39	35.11	11.66	46.69	100	270	Average

REMARKS:

- Emission Level = Read Level+ Antenna Factor + Cable Loss- Preamp Factor
Margin value = Emission level – Limit value.
- 5755MHz: Fundamental frequency.



Oobe Data

802.11ac (40MHz)

ANTENNA POLARITY & TEST DISTANCE: HORIZONTAL AT 3 M										
FREQ. (MHz)	EMISSION LEVEL (dBuV/m)	READ LEVEL (dBuV)	LIMIT (dBuV/m)	MARGIN (dB)	ANTENNA FACTOR (dB /m)	CABLE LOSS (dB)	PREAMP FACTOR (dB)	ANTENNA HEIGHT (cm)	TABLE ANGLE (Degree)	REMARK
5587.525	56.59	57.08	68.2	-11.61	34.56	11.59	46.64	100	0	Peak
6013.125	57.9	57.58	68.2	-10.3	35.31	11.77	46.76	100	0	Peak
ANTENNA POLARITY & TEST DISTANCE: VERTICAL AT 3 M										
FREQ. (MHz)	EMISSION LEVEL (dBuV/m)	READ LEVEL (dBuV)	LIMIT (dBuV/m)	MARGIN (dB)	ANTENNA FACTOR (dB /m)	CABLE LOSS (dB)	PREAMP FACTOR (dB)	ANTENNA HEIGHT (cm)	TABLE ANGLE (Degree)	REMARK
5575.175	57.52	57.75	68.2	-10.68	34.82	11.59	46.64	100	360	Peak
5975.125	57.85	57.4	68.2	-10.35	35.46	11.74	46.75	100	360	Peak

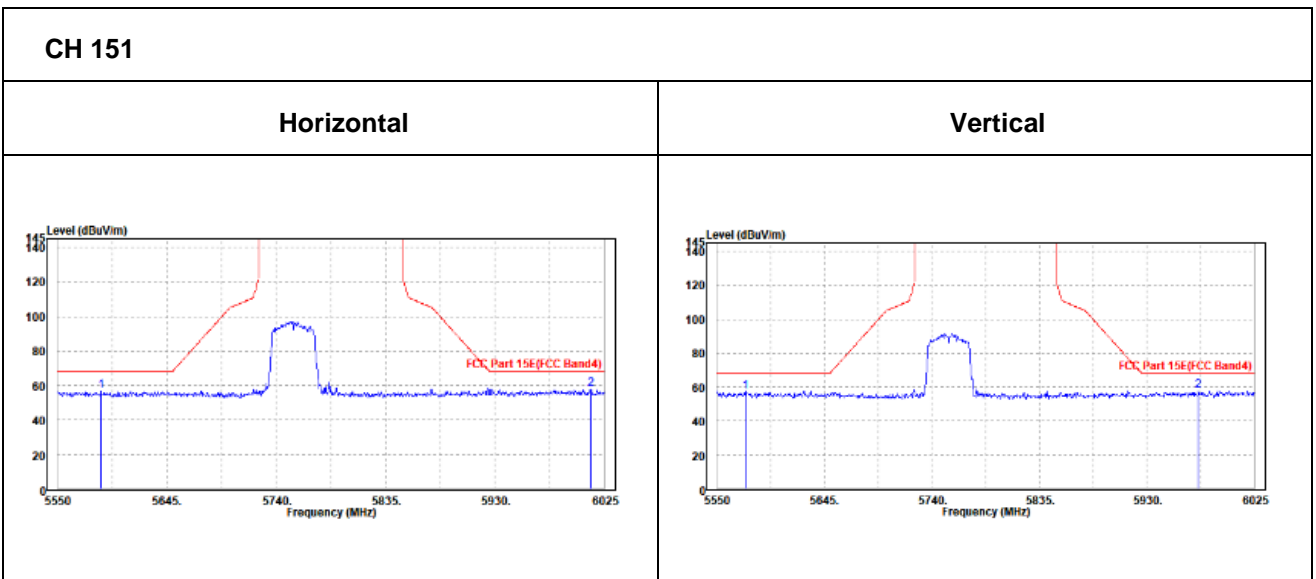



CHANNEL	TX Channel 159	DETECTOR FUNCTION	Peak (PK)
FREQUENCY RANGE	1GHz ~ 40GHz		Average (AV)

ANTENNA POLARITY & TEST DISTANCE: HORIZONTAL AT 3 M

FREQ. (MHz)	EMISSION LEVEL (dBuV/m)	READ LEVEL (dBuV)	LIMIT (dBuV/m)	MARGIN (dB)	ANTENNA FACTOR (dB /m)	CABLE LOSS (dB)	PREAMP FACTOR (dB)	ANTENNA HEIGHT (cm)	TABLE ANGLE (Degree)	REMARK
5795	95.79	95.89	74	21.79	34.93	11.67	46.7	100	190	Peak
5795	90.46	90.56	54	36.46	34.93	11.67	46.7	100	190	Average

ANTENNA POLARITY & TEST DISTANCE: VERTICAL AT 3 M

FREQ. (MHz)	EMISSION LEVEL (dBuV/m)	READ LEVEL (dBuV)	LIMIT (dBuV/m)	MARGIN (dB)	ANTENNA FACTOR (dB /m)	CABLE LOSS (dB)	PREAMP FACTOR (dB)	ANTENNA HEIGHT (cm)	TABLE ANGLE (Degree)	REMARK
5795	90.92	90.78	74	16.92	35.17	11.67	46.7	100	265	Peak
5795	85.82	85.68	54	31.82	35.17	11.67	46.7	100	265	Average

REMARKS:

- Emission Level = Read Level+ Antenna Factor + Cable Loss- Preamp Factor
Margin value = Emission level – Limit value.
- 5795MHz: Fundamental frequency.



OOBE DATA

802.11ac (40MHZ)

ANTENNA POLARITY & TEST DISTANCE: HORIZONTAL AT 3 M										
FREQ. (MHz)	EMISSION LEVEL (dBuV/m)	READ LEVEL (dBuV)	LIMIT (dBuV/m)	MARGIN (dB)	ANTENNA FACTOR (dB /m)	CABLE LOSS (dB)	PREAMP FACTOR (dB)	ANTENNA HEIGHT (cm)	TABLE ANGLE (Degree)	REMARK
5574.225	58.6	59.12	68.2	-9.6	34.53	11.59	46.64	100	360	Peak
5994.6	57.59	57.31	68.2	-10.61	35.29	11.75	46.76	100	360	Peak
ANTENNA POLARITY & TEST DISTANCE: VERTICAL AT 3 M										
FREQ. (MHz)	EMISSION LEVEL (dBuV/m)	READ LEVEL (dBuV)	LIMIT (dBuV/m)	MARGIN (dB)	ANTENNA FACTOR (dB /m)	CABLE LOSS (dB)	PREAMP FACTOR (dB)	ANTENNA HEIGHT (cm)	TABLE ANGLE (Degree)	REMARK
5559.975	57.98	58.24	68.2	-10.22	34.8	11.58	46.64	100	0	Peak
6014.075	58.35	57.83	68.2	-9.85	35.51	11.77	46.76	100	0	Peak

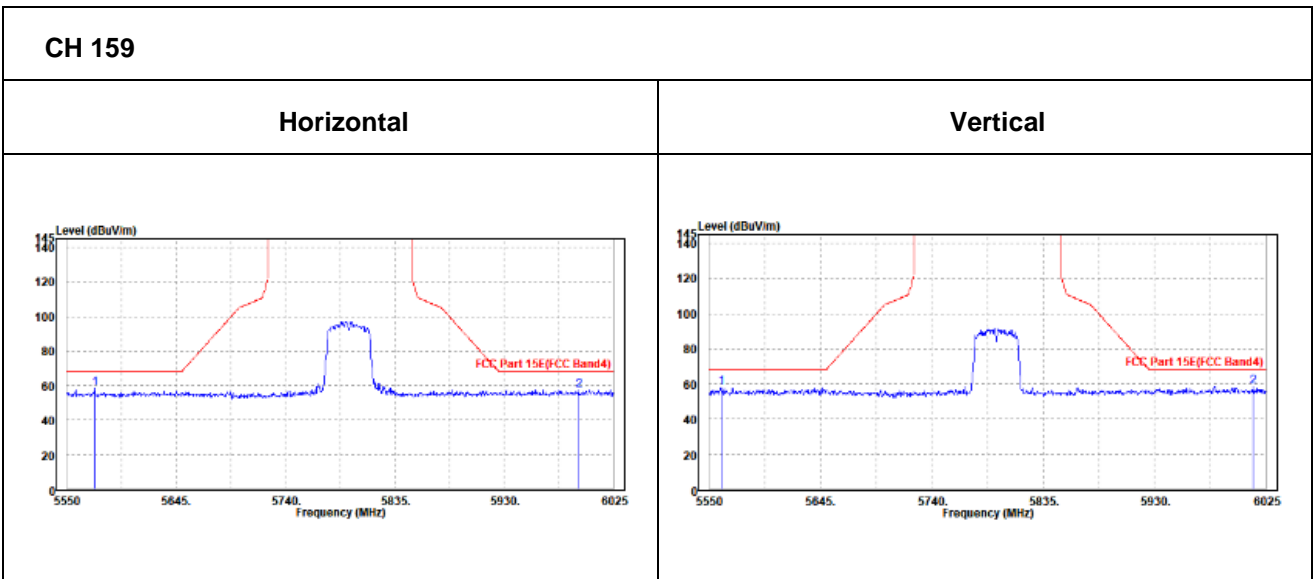



802.11ac (80MHz)

CHANNEL	TX Channel 155	DETECTOR FUNCTION	Peak (PK)
FREQUENCY RANGE	1GHz ~ 40GHz		Average (AV)

ANTENNA POLARITY & TEST DISTANCE: HORIZONTAL AT 3 M

FREQ. (MHz)	EMISSION LEVEL (dBuV/m)	READ LEVEL (dBuV)	LIMIT (dBuV/m)	MARGIN (dB)	ANTENNA FACTOR (dB /m)	CABLE LOSS (dB)	PREAMP FACTOR (dB)	ANTENNA HEIGHT (cm)	TABLE ANGLE (Degree)	REMARK
5775	92.09	92.23	74	18.09	34.9	11.66	46.7	100	190	Peak
5775	87.15	87.29	54	33.15	34.9	11.66	46.7	100	190	Average

ANTENNA POLARITY & TEST DISTANCE: VERTICAL AT 3 M

FREQ. (MHz)	EMISSION LEVEL (dBuV/m)	READ LEVEL (dBuV)	LIMIT (dBuV/m)	MARGIN (dB)	ANTENNA FACTOR (dB /m)	CABLE LOSS (dB)	PREAMP FACTOR (dB)	ANTENNA HEIGHT (cm)	TABLE ANGLE (Degree)	REMARK
5755	87.83	87.75	74	13.83	35.11	11.66	46.69	100	265	Peak
5755	81.94	81.86	54	27.94	35.11	11.66	46.69	100	265	Average

REMARKS:

- Emission Level = Read Level+ Antenna Factor + Cable Loss- Preamp Factor
Margin value = Emission level – Limit value.
- 5775MHz: Fundamental frequency.



Oobe Data

802.11ac (80MHz)

ANTENNA POLARITY & TEST DISTANCE: HORIZONTAL AT 3 M										
FREQ. (MHz)	EMISSION LEVEL (dBuV/m)	READ LEVEL (dBuV)	LIMIT (dBuV/m)	MARGIN (dB)	ANTENNA FACTOR (dB /m)	CABLE LOSS (dB)	PREAMP FACTOR (dB)	ANTENNA HEIGHT (cm)	TABLE ANGLE (Degree)	REMARK
5605.575	57.86	58.32	68.2	-10.34	34.59	11.6	46.65	100	0	Peak
5968	57.85	57.62	68.2	-10.35	35.24	11.74	46.75	100	0	Peak
ANTENNA POLARITY & TEST DISTANCE: VERTICAL AT 3 M										
FREQ. (MHz)	EMISSION LEVEL (dBuV/m)	READ LEVEL (dBuV)	LIMIT (dBuV/m)	MARGIN (dB)	ANTENNA FACTOR (dB /m)	CABLE LOSS (dB)	PREAMP FACTOR (dB)	ANTENNA HEIGHT (cm)	TABLE ANGLE (Degree)	REMARK
5635.5	57.54	57.67	68.2	-10.66	34.92	11.61	46.66	100	360	Peak
5941.875	58.87	58.47	68.2	-9.33	35.41	11.73	46.74	100	360	Peak

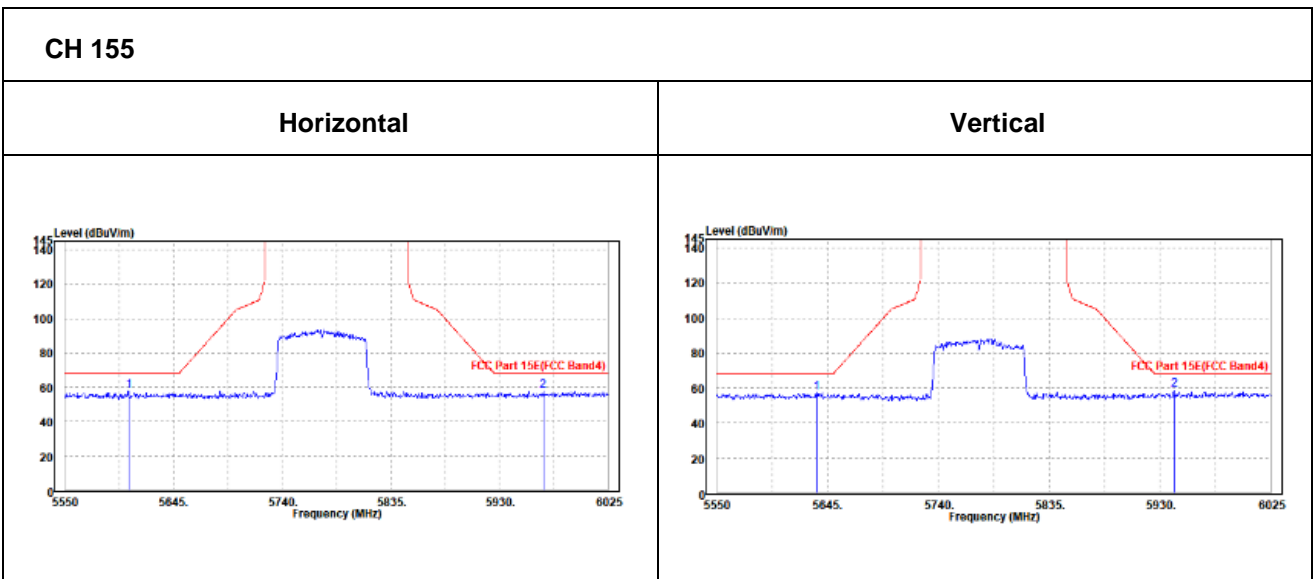



802.11ac (80MHZ)

Worst case harmonic:

CHANNEL	TX Channel 155	DETECTOR FUNCTION	Peak (PK)
FREQUENCY RANGE	1GHz ~ 40GHz		Average (AV)

ANTENNA POLARITY & TEST DISTANCE: HORIZONTAL AT 3 M

	Freq	Level	Read Level	Limit Line	Over Limit	Factor	Remark	Pol/Phase
	MHz	dBuV/m	dBuV	dBuV/m	dB	dB/m		
1	11550.000	55.16	44.50	74.00	-18.84	10.66	Peak	Horizontal
2	11550.000	47.25	36.59	54.00	-6.75	10.66	Average	Horizontal
3	PK17320.000	58.73	42.04	74.00	-15.27	16.69	Peak	Horizontal
4	PP17320.000	48.64	31.95	54.00	-5.36	16.69	Average	Horizontal

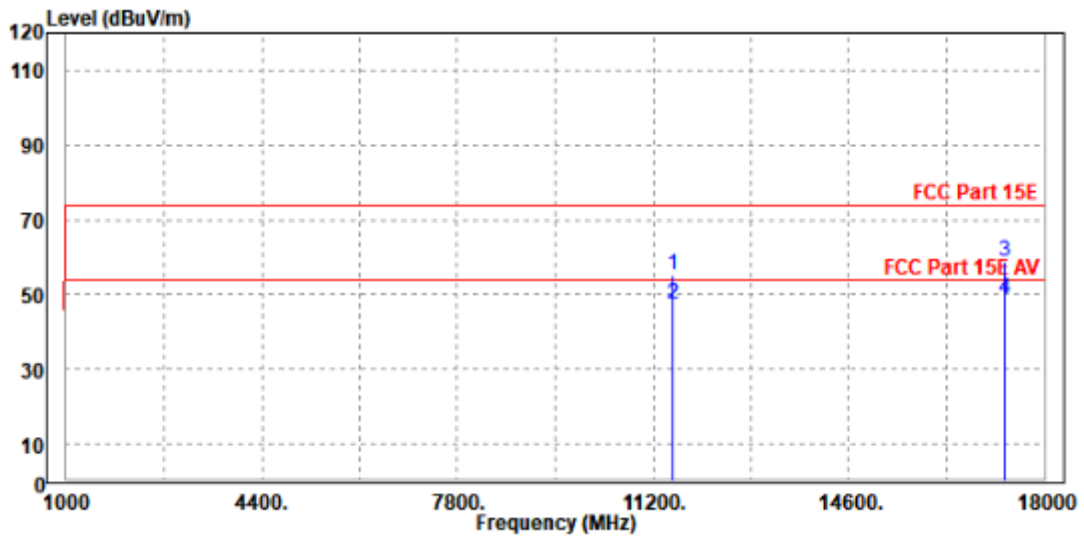



ANTENNA POLARITY & TEST DISTANCE: VERTICAL AT 3 M

	Freq	Level	Read Level	Limit Line	Over Limit	Factor	Remark	Pol/Phase
	MHz	dBuV/m	dBuV	dBuV/m	dB	dB/m		
1	11557.000	55.83	45.00	74.00	-18.17	10.83	Peak	Vertical
2	11557.000	47.76	36.93	54.00	-6.24	10.83	Average	Vertical
3	PK17325.000	59.03	42.20	74.00	-14.97	16.83	Peak	Vertical
4	PP17325.000	48.67	31.84	54.00	-5.33	16.83	Average	Vertical

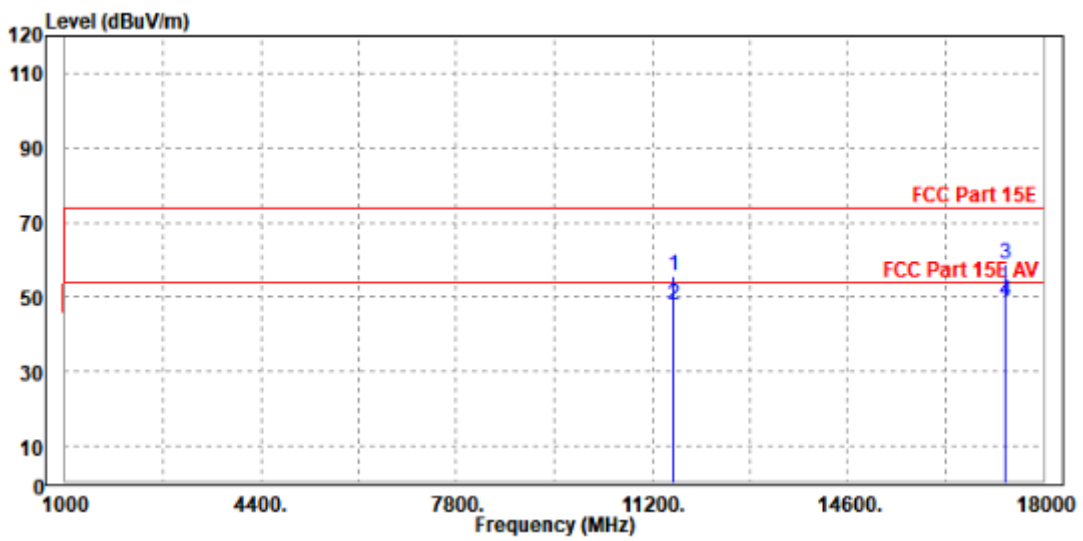

REMARKS:

1. Emission Level = Read Level+ Antenna Factor + Cable Loss- Preamp Factor
Margin value = Emission level – Limit value.
2. 5775MHz: Fundamental frequency.
3. For frequency above 18GHz, the emission was tested 20db below the limit so the data not recorded in the sheet.



3.2 CONDUCTED EMISSION MEASUREMENT

3.2.1 LIMITS OF CONDUCTED EMISSION MEASUREMENT

FREQUENCY OF EMISSION (MHz)	CONDUCTED LIMIT (dBµV)	
	Quasi-peak	Average
0.15 ~ 0.5	66 to 56	56 to 46
0.5 ~ 5	56	46
5 ~ 30	60	50

- NOTE:**
1. The lower limit shall apply at the transition frequencies.
 2. The limit decreases in line with the logarithm of the frequency in the range of 0.15 to 0.50MHz.
 3. All emanations from a class A/B digital device or system, including any network of conductors and apparatus connected thereto, shall not exceed the level of field strengths specified above.

3.2.2 TEST INSTRUMENTS

Equipment	Manufacturer	Model No.	Serial No.	Last Cal.	Next Cal.
EMI Test Receiver	Rohde&Schwarz	ESR3	101900	Feb. 14,24	Feb. 13,25
EMC32 test software	Rohde&Schwarz	EMC32	NA	NA	NA
LISN network	Rohde&Schwarz	ENV216	101922	Mar. 10,24	Mar. 09,25

NOTE:

1. The test was performed in CE shielded room.
2. The calibration interval of the above test instruments is 12 months. And the calibrations are traceable to CEPREI/CHINA, GRGT/CHINA and NIM/CHINA.

3.2.3 TEST PROCEDURES

- a. The EUT was placed 0.4 meters from the conducting wall of the shielded room with EUT being connected to the power mains through a line impedance stabilization network (LISN). Other support units were connected to the power mains through another LISN. The two LISNs provide 50 ohm/ 50uH of coupling impedance for the measuring instrument.
- b. Both lines of the power mains connected to the EUT were checked for maximum conducted interference.
- c. The frequency range from 150kHz to 30MHz was searched. Emission levels under (Limit - 20dB) was not recorded.

NOTE: All modes of operation were investigated and the worst-case emissions are reported.



3.2.4 DEVIATION FROM TEST STANDARD

No deviation.

3.2.5 TEST SETUP

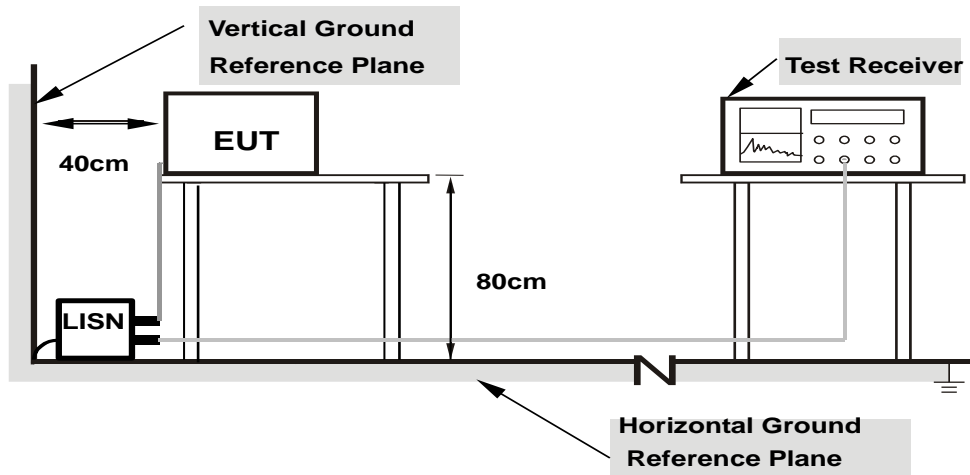

- Note: 1.Support units were connected to second LISN.
2.Both of LISNs (AMN) are 80 cm from EUT and at least 80
from other units and other metal planes**

For the actual test configuration, please refer to the attached file (Test Setup Photo).

3.2.6 EUT OPERATING CONDITIONS

Same as 3.1.7.



3.2.7 TEST RESULTS

CONDUCTED WORST-CASE DATA:

Frequency Range	150KHz ~ 30MHz	Detector Function & Resolution Bandwidth	Quasi-Peak (QP) / Average (AV), 9 kHz
Input Power	120Vac, 60Hz	Environmental Conditions	26deg. C, 51%RH
Tested By	Carl Xie		

Frequency (MHz)	QuasiPeak (dBuV)	CAverage (dBuV)	Limit (dBuV)	Margin (dB)	Line	Filter	Corr. (dB)
0.150000	---	19.13	56.00	36.87	L1	ON	9.8
0.150000	37.99	---	66.00	28.01	L1	ON	9.8
0.484000	---	27.83	46.27	18.44	L1	ON	9.8
0.484000	35.05	---	56.27	21.22	L1	ON	9.8
1.000000	---	22.29	46.00	23.71	L1	ON	9.8
1.000000	28.63	---	56.00	27.37	L1	ON	9.8
1.636000	---	20.73	46.00	25.27	L1	ON	9.8
1.636000	30.57	---	56.00	25.43	L1	ON	9.8
2.924000	---	19.29	46.00	26.71	L1	ON	9.9
2.924000	27.79	---	56.00	28.21	L1	ON	9.9
13.900000	---	14.01	50.00	35.99	L1	ON	10.8
13.900000	28.40	---	60.00	31.60	L1	ON	10.8

- REMARKS:**
1. Q.P. and AV. are abbreviations of quasi-peak and average individually.
 2. "-": The Quasi-peak reading value also meets average limit and measurement with the average detector is unnecessary.
 3. The emission levels of other frequencies were very low against the limit.
 4. Margin value = Limit value - Emission level
 5. Correction factor = Insertion loss + Cable loss
 6. Emission Level = Correction Factor + Reading Value.

Full Spectrum

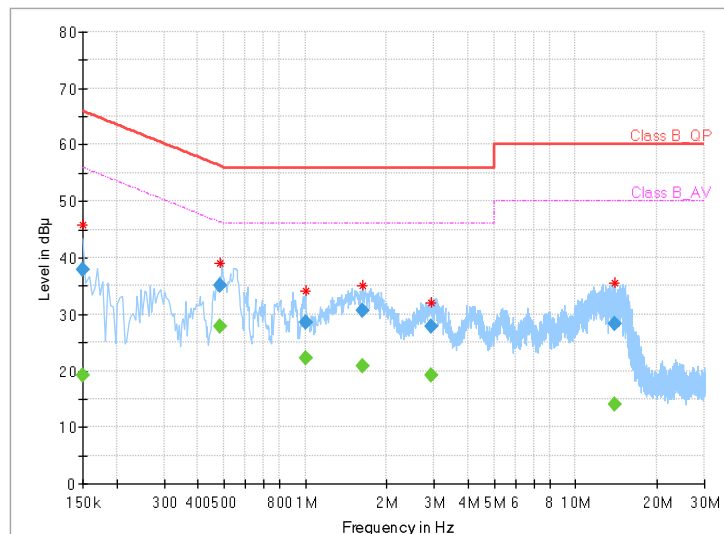



Frequency Range	150KHz ~ 30MHz	Detector Function & Resolution Bandwidth	Quasi-Peak (QP) / Average (AV), 9 kHz
Input Power	120Vac, 60Hz	Environmental Conditions	26deg. C, 51%RH
Tested By	Carl Xie		

Frequency (MHz)	QuasiPeak (dBuV)	CAverage (dBuV)	Limit (dBuV)	Margin (dB)	Line	Filter	Corr. (dB)
0.150000	---	19.13	56.00	36.87	N	ON	9.7
0.150000	37.41	---	66.00	28.59	N	ON	9.7
0.466000	---	18.04	46.59	28.55	N	ON	9.6
0.466000	29.64	---	56.59	26.95	N	ON	9.6
0.556000	---	24.37	46.00	21.63	N	ON	9.7
0.556000	35.34	---	56.00	20.66	N	ON	9.7
0.988000	---	18.32	46.00	27.68	N	ON	9.7
0.988000	29.35	---	56.00	26.65	N	ON	9.7
1.464000	---	19.59	46.00	26.41	N	ON	9.7
1.464000	29.18	---	56.00	26.82	N	ON	9.7
14.000000	---	19.67	50.00	30.33	N	ON	10.8
14.000000	28.59	---	60.00	31.41	N	ON	10.8

- REMARKS:**
1. Q.P. and AV. are abbreviations of quasi-peak and average individually.
 2. "-": The Quasi-peak reading value also meets average limit and measurement with the average detector is unnecessary.
 3. The emission levels of other frequencies were very low against the limit.
 4. Margin value = Limit value - Emission level
 5. Correction factor = Insertion loss + Cable loss
 6. Emission Level = Correction Factor + Reading Value.

Full Spectrum

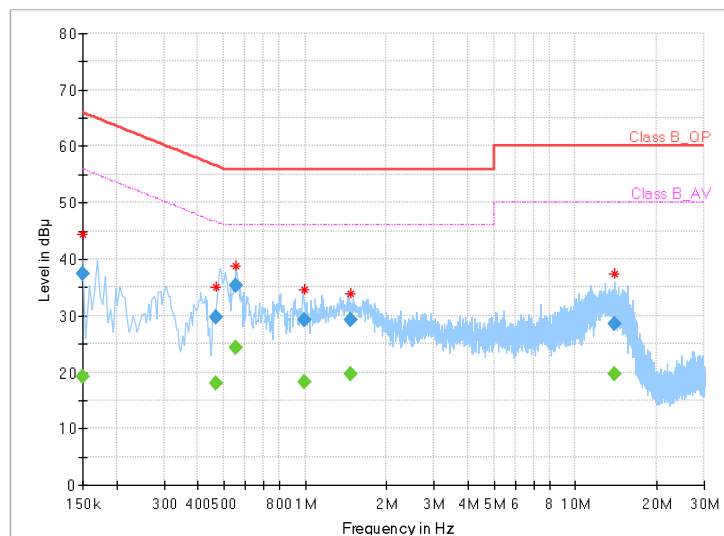



3.3 MAXIMUM CONDUCTED OUTPUT POWER MEASUREMENT

3.3.1 LIMITS OF MAXIMUM CONDUCTED OUTPUT POWER MEASUREMENT

Operation Band	EUT Category		LIMIT
U-NII-1		Outdoor Access Point	1 Watt (30 dBm) (Max. e.i.r.p \leq 125mW(21 dBm) at any elevation angle above 30 degrees as measured from the horizon)
		Fixed point-to-point Access Point	1 Watt (30 dBm)
	B	Indoor Access Point	1 Watt (30 dBm)
	√	Client devices	250mW (24 dBm)
U-NII-2A	√		250mW (24 dBm) or 11 dBm+10 log B*
U-NII-2C	√		250mW (24 dBm) or 11 dBm+10 log B*
U-NII-3	√		1 Watt (30 dBm)

NOTE: Where B is the 26dB emission bandwidth in MHz.



3.3.2 TEST SETUP

FOR POWER OUTPUT MEASUREMENT

802.11a, 802.11n/ac (20MHz), 802.11 n/ac (40MHz),802.11ac (80MHz) TEST CONFIGURATION

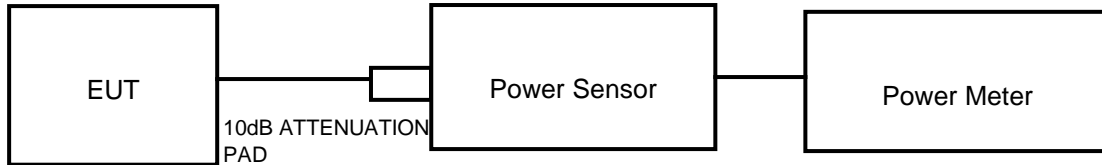

FOR 26dB BANDWIDTH

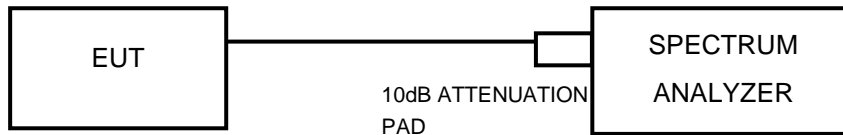

3.3.3 TEST INSTRUMENTS

Equipment	Manufacturer	Model No.	Serial No.	Last Cal.	Next Cal.
Power Meter	ANRITSU	ML2495A	1506002	Feb. 14,24	Feb. 13,25
EXA Signal Analyzer	KEYSIGHT	N9010A-526	MY54510523	Feb. 14,24	Feb. 13,25
EXA Signal Analyzer	KEYSIGHT	N9010A-544	MY54510355	May.10,23	May.09,24
EXA Signal Analyzer	KEYSIGHT	N9010A-544	MY54510355	May.09,24	May.08,25
Power Sensor	ANRITSU	MA2411B	1339352	Feb. 14,24	Feb. 13,25

NOTE:

1. The calibration interval of the above test instruments is 12 months, and the calibrations are traceable to CEPREI/CHINA, GRGT/CHINA and NIM/CHINA.
2. The test was performed in the RF Oven room.



3.3.4 TEST PROCEDURE

FOR POWER MEASUREMENT

For 802.11a, 802.11 n/ac (20MHz), 802.11 n/ac (40MHz) , 802.11 ac (80MHz)

Method PM is used to perform output power measurement, trigger and gating function of wide band power meter is enabled to measure max output power of TX on burst. Duty factor is not added to measured value.

FOR 99 PERCENT OCCUPIED BANDWIDTH

The following procedure shall be used for measuring (99 %) power bandwidth:

1. Set center frequency to the nominal EUT channel center frequency.
2. Set span = 1.5 times to 5.0 times the OBW.
3. Set RBW = 1 % to 5 % of the OBW
4. Set VBW $\geq 3 \cdot$ RBW
5. Video averaging is not permitted. Where practical, a sample detection and single sweep mode shall be used. Otherwise, peak detection and max hold mode (until the trace stabilizes) shall be used.
6. Use the 99 % power bandwidth function of the instrument (if available).
7. If the instrument does not have a 99 % power bandwidth function, the trace data points are recovered and directly summed in power units. The recovered amplitude data points, beginning at the lowest frequency, are placed in a running sum until 0.5 % of the total is reached; that frequency is recorded as the lower frequency. The process is repeated until 99.5 % of the total is reached; that frequency is recorded as the upper frequency. The 99% occupied bandwidth is the difference between these two frequencies.

FOR 26dB BANDWIDTH

- 1) Set RBW = approximately 1% of the emission bandwidth.
- 2) Set the VBW > RBW.
- 3) Detector = Peak.
- 4) Trace mode = max hold.
- 5) Measure the maximum width of the emission that is 26 dB down from the peak of the emission. Compare this with the RBW setting of the analyzer. Readjust RBW and repeat measurement as needed until the RBW/EBW ratio is approximately 1%.



FOR 6dB BANDWIDTH

1. Set RBW = 100 kHz.
2. Set the video bandwidth (VBW) ≥ 3 RBW.
3. Detector = Peak.
4. Trace mode = max hold.
5. Sweep = auto couple.
6. Allow the trace to stabilize.
7. Measure the maximum width of the emission that is constrained by the frequencies associated with the two outermost amplitude points (upper and lower frequencies) that are attenuated by 6 dB relative to the maximum level measured in the fundamental emission.



3.3.5 DEVIATION FROM TEST STANDARD

No deviation.

3.3.6 EUT OPERATING CONDITIONS

The software provided by the client to enable the EUT under transmission condition continuously at specific channel frequencies individually.



BUREAU Test Report No.: W7L-240507W001RF03
VERITAS

3.3.7 TEST RESULTS

Please Refer to Appendix C.



3.4 MAXIMUM POWER SPECTRAL DENSITY MEASUREMENT

3.4.1 LIMITS OF MAXIMUM POWER SPECTRAL DENSITY MEASUREMENT

Operation Band	EUT Category		LIMIT
U-NII-1		Outdoor Access Point	17dBm/ MHz
		Fixed point-to-point Access Point	
		Indoor Access Point	
	√	Client devices	11dBm/ MHz
U-NII-2A	√		11dBm/ MHz
U-NII-2C	√		11dBm/ MHz
U-NII-3	√		30dBm/ 500kHz

3.4.2 TEST SETUP

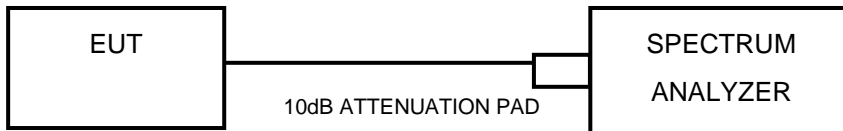

3.4.3 TEST INSTRUMENTS

Refer to section 3.3.3 to get information about the above instrument.



3.4.4 TEST PROCEDURES

Using method SA-2(Band1/2/3)

- 1) Set span to encompass the entire emission bandwidth (EBW) of the signal.
- 2) Set RBW = 1 MHz, Set VBW \geq 3 MHz, Detector = RMS
- 3) Set Channel power measure = 1MHz
- 4) Sweep time = auto, trigger set to "free run".
- 5) Trace average at least 100 traces in power averaging mode.
- 6) Add $10 \log(1/x)$, where x is the duty cycle, to the measured power in order to compute the average power during the actual transmission times (because the measurement represents an average over both the on and off times of the transmission).
- 7) Record the max value

Using method SA-2 (Band4)

- 1) Set span to encompass the entire emission bandwidth (EBW) of the signal.
- 2) Set RBW = 300 KHz, Set VBW \geq 1 MHz, Detector = RMS
- 3) Set Channel power measure = 1MHz
- 4) Sweep time = auto, trigger set to "free run".
- 5) Trace average at least 100 traces in power averaging mode.
- 6) Add $10 \log(500\text{kHz}/\text{RBW})$ to the test result. $10 \log(500\text{kHz}/300\text{KHZ}) = 2.22\text{dBm}$
- 7) Add $10 \log(1/x)$, where x is the duty cycle, to the measured power in order to compute the average power during the actual transmission times (because the measurement represents an average over both the on and off times of the transmission).
- 8) Record the max value

3.4.5 DEVIATION FROM TEST STANDARD

No deviation.

3.4.6 EUT OPERATING CONDITIONS

Same as 3.1.7.



BUREAU Test Report No.: W7L-240507W001RF03
VERITAS

3.4.7 TEST RESULTS

Please Refer to Appendix C.



3.5 AUTOMATICALLY DISCONTINUE TRANSMISSION

3.5.1 LIMIT OF AUTOMATICALLY DISCONTINUE TRANSMISSION

The device shall automatically discontinue transmission in case of either absence of information to transmit or operational failure. These provisions are not intended to preclude the transmission of control or signaling information, or the use of repetitive codes used by certain digital technologies to complete frame or burst intervals. Applicants shall include in their application for equipment authorization a description of how this requirement is met.

3.5.2 TEST INSTRUMENTS

Refer to section 3.3.3 to get information about the above instrument.

3.5.3 TEST RESULT

While the EUT is not transmitting any information, the EUT can automatically discontinue transmission and become standby mode for power saving。 The EUT can detect the controlling of ACK message transmitting from remote device and verify whether it shall resend or discontinue transmission.



3.6 ANTENNA REQUIREMENTS

3.6.1 STANDARD APPLICABLE

If transmitting antenna directional gain is greater than 6 dBi, both the peak transmits power and the peak power spectral density shall be reduced by the amount in dB that the directional gain of the antenna exceeds 6 dBi.

3.6.2 ANTENNA CONNECTED CONSTRUCTION

An embedded-in antenna design is used.

3.6.3 ANTENNA GAIN

The antenna peak gain of EUT is less than 6 dBi. Therefore, it is not necessary to reduce maximum peak output power limit and PSD limit.

4 PHOTOGRAPHS OF THE TEST CONFIGURATION

Please refer to the attached file (Test Setup Photo).



5 MODIFICATIONS RECORDERS FOR ENGINEERING CHANGES TO THE EUT BY THE LAB

No modifications were made to the EUT by the lab during the test.

---END---