

FCC TEST REPORT (PART 24)



Applicant:	Xiaomi Communications Co., Ltd.
Address:	#019, 9th Floor, Building 6, 33 Xi'erqi Middle Road, Haidian District, Beijing, China, 100085

Manufacturer or Supplier:	Xiaomi Communications Co., Ltd.
Address:	#019, 9th Floor, Building 6, 33 Xi'erqi Middle Road, Haidian District, Beijing, China, 100085
Product:	Mobile Phone
Brand Name:	Redmi
Model Name:	23053RN02L
FCC ID:	2AFZZRN02L
Date of tests:	Mar. 06, 2023 ~ Mar. 29, 2023

The tests have been carried out according to the requirements of the following standard:

- FCC PART 24, Subpart E**
 FCC PART 2
 ANSI/TIA/EIA-603-D
 ANSI/TIA/EIA-603-E
 ANSI C63.26-2015

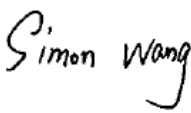
CONCLUSION: The submitted sample was found to COMPLY with the test requirement

Prepared by Simon Wang Engineer / Mobile Department	Approved by Luke Lu Manager / Mobile Department
	
Date: Mar. 29, 2023	Date: Mar. 29, 2023

This report is governed by, and incorporates by reference, the Conditions of Testing as posted at the date of issuance of this report at <http://www.bureauveritas.com/home/about-us/our-business/cps/about-us/terms-conditions/> and is intended for your exclusive use. Any copying or replication of this report to or for any other person or entity, or use of our name or trademark, is permitted only with our prior written permission. This report sets forth our findings solely with respect to the test samples identified herein. The results set forth in this report are not indicative or representative of the quality or characteristics of the lot from which a test sample was taken or any similar or identical product unless specifically and expressly noted. Our report includes all of the tests requested by you and the results thereof based upon the information that you provided to us. Measurement uncertainty is only provided upon request for accredited tests. Statements of conformity are based on simple acceptance criteria without taking measurement uncertainty into account, unless otherwise requested in writing. You have 60 days from date of issuance of this report to notify us of any material error or omission caused by our negligence or if you require measurement uncertainty; provided, however, that such notice shall be in writing and shall specifically address the issue you wish to raise. A failure to raise such issue within the prescribed time shall constitute your unqualified acceptance of the completeness of this report, the tests conducted and the correctness of the report contents.



TABLE OF CONTENTS

RELEASE CONTROL RECORD	4
1 SUMMARY OF TEST RESULTS	5
1.1 MEASUREMENT UNCERTAINTY	6
1.2 TEST SITE AND INSTRUMENTS	7
2 GENERAL INFORMATION	9
2.1 GENERAL DESCRIPTION OF EUT	9
2.2 CONFIGURATION OF SYSTEM UNDER TEST	12
2.3 DESCRIPTION OF SUPPORT UNITS	13
2.4 TEST ITEM AND TEST CONFIGURATION.....	13
2.5 EUT OPERATING CONDITIONS	16
2.6 GENERAL DESCRIPTION OF APPLIED STANDARDS	16
3 TEST TYPES AND RESULTS	17
3.1 OUTPUT POWER MEASUREMENT	17
3.1.1 LIMITS OF OUTPUT POWER MEASUREMENT	17
3.1.2 TEST PROCEDURES	17
3.1.3 TEST SETUP	18
3.1.4 TEST RESULTS	18
3.2 FREQUENCY STABILITY MEASUREMENT	46
3.2.1 LIMITS OF FREQUENCY STABILITY MEASUREMENT	46
3.2.2 TEST PROCEDURE	46
3.2.3 TEST SETUP	46
3.2.4 TEST RESULTS	47
3.3 OCCUPIED BANDWIDTH MEASUREMENT	48
3.3.1 LIMITS OF OCCUPIED BANDWIDTH MEASUREMENT	48
3.3.2 TEST SETUP	48
3.3.3 TEST PROCEDURES	48
3.3.4 TEST RESULTS	49
3.4 BAND EDGE MEASUREMENTC	50
3.4.1 LIMITS OF BAND EDGE MEASUREMENT	50
3.4.2 TEST SETUP	50
3.4.3 TEST PROCEDURES	51
3.4.4. TEST RESULTS	52
3.5 CONDUCTED SPURIOUS EMISSIONS.....	53
3.5.1 LIMITS OF CONDUCTED SPURIOUS EMISSIONS MEASUREMENT	53
3.5.2 TEST PROCEDURE	53
3.5.3 TEST SETUP	53
3.5.4 TEST RESULTS	54
3.6 RADIATED EMISSION MEASUREMENT	55
3.6.1 LIMITS OF RADIATED EMISSION MEASUREMENT	55
3.6.2 TEST PROCEDURES	55



BUREAU
VERITAS

Test Report No.: W7L-P23030003RF05

3.6.3 DEVIATION FROM TEST STANDARD	55
3.6.4 TEST SETUP	56
3.6.5 TEST RESULTS	58
3.7 PEAK TO AVERAGE RATIO	94
3.7.1 LIMITS OF PEAK TO AVERAGE RATIO MEASUREMENT	94
3.7.2 TEST SETUP	94
3.7.3 TEST PROCEDURES	94
3.7.4 TEST RESULTS	95
4 INFORMATION ON THE TESTING LABORATORIES	96
5 MODIFICATIONS RECORDERS FOR ENGINEERING CHANGES TO THE EUT BY THE LAB.....	97
6 APPENDIX	98
GSM1900	98
WCDMA BAND2	116
LTE BAND2	127



BUREAU
VERITAS

Test Report No.: W7L-P23030003RF05

RELEASE CONTROL RECORD

ISSUE NO.	REASON FOR CHANGE	DATE ISSUED
W7L-P23030003RF05	Original release	Mar. 29, 2023



1 SUMMARY OF TEST RESULTS

The EUT has been tested according to the following specifications:

APPLIED STANDARD: FCC Part 24 & Part 2			
STANDARD SECTION	TEST TYPE	RESULT	TEST LAB*
§2.1046	Conducted Output Power	Compliance	A
§24.232(c)	Equivalent Isotropic Radiated Power	Compliance	A
§2.1055 §24.235	Frequency Stability	Compliance	A
§2.1049	Occupied Bandwidth	Compliance	A
§24.232(d)	Peak to average ratio	Compliance	A
§24.238(a)(b)	Band Edge Measurements	Compliance	A
§2.1051 §24.238(a)(b)	Conducted Spurious Emissions	Compliance	A
§2.1053 §24.238(a)(b)	Radiated Spurious Emissions	Compliance	B

***Test Lab Information Reference**

Lab A:

BV 7Layers Communications Technology (Shenzhen) Co., Ltd

Lab Address:

No.B102, Dazu Chuangxin Mansion, North of Beihuan Avenue, North Area, Hi-Tech Industrial Park, Nanshan District, Shenzhen, Guangdong, China

Accredited Test Lab Cert 3939.01

The FCC Site Registration No. : 525120; Designation No. : CN1171;

Lab B:

Huarui 7Layers High Technology (Suzhou) Co., Ltd.

Lab Address:

Tower N, Innovation Center, 88 Zhuyi Road, High-tech District, Suzhou City, Anhui Province

Accredited Test Lab Cert 6613.01

The FCC Site Registration No. is 434559; The Designation No. is CN1325.



1.1 MEASUREMENT UNCERTAINTY

Where relevant, the following measurement uncertainty levels have been estimated for tests performed on the EUT as specified in CISPR 16-4-2:

MEASUREMENT	UNCERTAINTY
Frequency Stability	± 76.97Hz
Radiated emissions (9KHz~30MHz)	±2.68dB
Radiated emissions & Radiated Power (30MHz~1GHz)	±4.98dB
Radiated emissions & Radiated Power (1GHz ~6GHz)	±4.70dB
Radiated emissions (6GHz ~18GHz)	±4.60dB
Radiated emissions (18GHz ~40GHz)	±4.12dB
Conducted emissions	±4.01dB
Occupied Channel Bandwidth	±43.58KHz
Conducted Output power	±2.06dB
Band Edge Measurements	±4.70dB
Peak to average ratio	±0.76dB

This uncertainty represents an expanded uncertainty expressed at approximately the 95% confidence level using a coverage factor of k=2.



1.2 TEST SITE AND INSTRUMENTS

Equipment	Manufacturer	Model No.	Serial No.	Last Cal.	Next Cal.
MXE EMI Receiver	KEYSIGHT	N9038A-544	MY54450026	Feb. 17,23	Feb. 16,24
EXA Signal Analyzer	KEYSIGHT	N9010A-544	MY54510355	May.14,22	May.13,23
Loop Antenna	Schwarzbeck	FMZB 1519B	00173	Sep.03,22	Sep.02,23
Bilog Antenna	ETS-LINDGREN	3143B	00161965	Mar. 05,23	Mar. 04,24
Horn Antenna	ETS-LINDGREN	3117	00168692	Mar. 05,23	Mar. 04,24
Horn Antenna (18GHz-40GHz)	N/A	QWH-SL-18-40- K-SG/QMS-003 61	15433	Sep.04, 22	Sep.03, 23
Radio Communication Analyzer	ANRITSU	MT8820C	6201465426	Feb. 14,23	Feb. 13,24
Signal Pre-Amplifier	EMSI	EMC 9135	980249	May.12,22	May.11,23
Signal Pre-Amplifier	EMSI	EMC 012645B	980257	May.12,22	May.11,23
Signal Pre-Amplifier	EMSI	EMC 184045B	980259	Feb. 17,23	Feb.16,24
3m Semi-anechoic Chamber	ETS-LINDGREN	9m*6m*6m	Euroshieldpn- CT0001143-121 6	May. 19,20	May. 18,23
Test Software	E3	V 9.160323	N/A	N/A	N/A
Test Software	JS1120	3.1.36	N/A	N/A	N/A
10dB Attenuator	JFW/USA	50HF-010-SMA	N/A	May. 12,22	May. 11,23
Power Meter	Anritsu	ML2495A	1506002	Feb. 14,23	Feb. 13,24
Power Sensor	Anritsu	MA2411B	1339352	Feb. 14,23	Feb. 13,24
Temperature Chamber	ESPEC	SH-242	93000855	May. 12,22	May. 11,23
MXG Analog Microwave Signal Generator	KEYSIGHT	N5183A	MY50143024	Feb. 14,23	Feb. 13,24
Base station R&S CMW500	Rohde&Schwarz	CMW500	153085	May.12,22	May.11,23
DC Source	Kikusui/JP	PMX18-5A	N/A	Aug. 12,22	Aug. 11,23

- NOTE:** 1. The calibration interval of the above test instruments is 12 months or 36 months and the calibrations are traceable to CEPREI/CHINA, GRGT/CHINA and NIM/CHINA.
2. The test was performed in 3m Semi-anechoic Chamber and RF Oven Room.
3. The horn antenna is used only for the measurement of emission frequency above 1GHz if tested.
4. The FCC Site Registration No. is 525120; The Designation No. is CN1171.



Equipment	Manufacturer	Model No.	Serial No.	Last Cal.	Next Cal.
Pre-Amplifier	R&S	SCU18F1	100815	Aug.30,22	Aug.29,24
Pre-Amplifier	R&S	SCU08F1	101028	Sep.16,22	Sep.15,24
Vector Signal Generator	R&S	SMBV100B	102176	Feb.16,22	Feb.15,24
Signal Generator	R&S	SMB100A	182185	Feb.16,22	Feb.15,24
3m Fully-anechoic Chamber	TDK	9m*6m*6m	HRSW-SZ-EMC-01Chamber	Nov.25,22	Nov.24,25
3m Semi-anechoic Chamber	TDK	9m*6m*6m	HRSW-SZ-EMC-02Chamber	Nov.25,22	Nov.24,25
EMI TEST Receiver	R&S	ESR26	101734	Feb.25,22	Feb.24,24
EMI TEST Receiver	R&S	ESW44	101973	Feb.25,22	Feb.24,24
Bilog Antenna	SCHWARZBECK	VULB 9163	1264	Feb.28,22	Feb.27,24
Horn Antenna	ETS-LINDGREN	3117	227836	Aug.22,22	Aug.21,24
Horn Antenna (18GHz-40GHz)	Steatite Q-par Antennas	QMS 00880	23486	Feb.23,22	Feb.22,24
Horn Antenna	Steatite Q-par Antennas	QMS 00208	23485	Aug.22,22	Aug.21,24
Loop Antenna	SCHWARZ	HFH2-Z2/Z2E	100976	Feb.23,22	Feb.22,24
WIDEBANDRADIO COMMUNICATION TESTER	R&S	CMW500	169399	Jun.27,22	Jun.26,24
Test Software	EMC32	EMC32	N/A	N/A	N/A
Test Software	ELEKTRA	ELEKTRA4.32	N/A	N/A	N/A
Open Switch and Control Unit	R&S	OSP220	101964	Oct.01,22	Sep.30,24
DC Source	HYELEC	HY3010B	551016	Aug.31,22	Aug.30,24
Hygrothermograph	DELI	20210528	SZ014	Sep.06,22	Sep.05,24
PC	LENOVO	E14	HRSW0024	N/A	N/A
TMC-AMI18843A(CABLE)	R&S	HF290-NMNM-7.00M	N/A	N/A	N/A
TMC-AMI18843A(CABLE)	R&S	HF290-NMNM-4.00M	N/A	N/A	N/A
CABLE	R&S	W13.02	N/A	Oct.31,22	Apr.29,23
CABLE	R&S	W12.14	N/A	Oct.31,22	Apr.29,23
CABLE	R&S	J12J103539-00-1	SEP-03-20-069	Oct.31,22	Apr.29,23
CABLE	R&S	J12J103539-00-1	SEP-03-20-070	Oct.31,22	Apr.29,23
Temperature Chamber	votsch	VT4002	58566078100050	May.31,22	May.30,24

- NOTE:**
1. The calibration interval of the above test instruments is 12 months or 36 months and the calibrations are traceable to CEPREI/CHINA, GRGT/CHINA and NIM/CHINA.
 2. The test was performed in 3m Semi-anechoic Chamber and RF Oven Room.
 3. The horn antenna is used only for the measurement of emission frequency above 1GHz if tested.
 4. The FCC Site Registration No. is 434559; The Designation No. is CN1325.



2 GENERAL INFORMATION

2.1 GENERAL DESCRIPTION OF EUT

PRODUCT	Mobile Phone	
BRAND NAME	Redmi	
MODEL NAME	23053RN02L	
NOMINAL VOLTAGE	5V/9V/10V/12Vdc(adapter or host equipment) 3.8Vdc (Li-ion, battery)	
MODULATION TYPE	GSM: GMSK EDGE: 8PSK WCDMA: BPSK, QPSK LTE Band 2: QPSK, 16QAM, 64QAM	
FREQUENCY RANGE	GSM, EDGE	1850.2MHz ~ 1909.8MHz
	WCDMA	1852.4MHz ~ 1907.6MHz
	LTE Band 2 Channel Bandwidth: 1.4MHz	1850.7MHz ~ 1909.3MHz
	LTE Band 2 Channel Bandwidth: 3MHz	1851.5MHz ~ 1908.5MHz
	LTE Band 2 Channel Bandwidth: 5MHz	1852.5MHz ~ 1907.5MHz
	LTE Band 2 Channel Bandwidth: 10MHz	1855.0MHz ~ 1905.0MHz
	LTE Band 2 Channel Bandwidth: 15MHz	1857.5MHz ~ 1902.5MHz
	LTE Band 2 Channel Bandwidth: 20MHz	1860.0MHz ~ 1900.0MHz
	MAX. EIRP POWER	GSM
EDGE		256.45mW
WCDMA		174.58mW
LTE Band 2 Channel Bandwidth: 1.4MHz		167.88mW
LTE Band 2 Channel Bandwidth: 3MHz		168.27mW
LTE Band 2 Channel Bandwidth: 5MHz		166.72mW
LTE Band 2 Channel Bandwidth: 10MHz		167.49mW
LTE Band 2 Channel Bandwidth: 15MHz		168.27mW



	LTE Band 2 Channel Bandwidth: 20MHz	169.82mW	
EMISSION DESIGNATOR	GSM	247KGXW	
	EDGE	251KG7W	
	WCDMA	4M19F9W	
	LTE Band 2 Channel Bandwidth: 1.4MHz	QPSK: 1M09G7D	
		16QAM: 1M09W7D	
		64QAM: 1M09W7D	
	LTE Band 2 Channel Bandwidth: 3MHz	QPSK: 2M69G7D	
		16QAM: 2M69W7D	
		64QAM: 2M70W7D	
	LTE Band 2 Channel Bandwidth: 5MHz	QPSK: 4M50G7D	
		16QAM: 4M51W7D	
		64QAM: 4M50W7D	
	LTE Band 2 Channel Bandwidth: 10MHz	QPSK: 8M99G7D	
		16QAM: 8M99W7D	
		64QAM: 8M99W7D	
	LTE Band 2 Channel Bandwidth: 15MHz	QPSK: 13M5G7D	
16QAM: 13M5W7D			
64QAM: 13M5W7D			
LTE Band 2 Channel Bandwidth: 20MHz	QPSK: 18M0G7D		
	16QAM: 18M0W7D		
	64QAM: 18M0W7D		
ANTENNA TYPE	ANT 0: IFA Antenna with -1.88dBi gain for GSM1900/ WCDMA II/LTE B2 ANT 4: IFA Antenna with -1.72dBi gain for GSM1900/ WCDMA II/LTE B2		
HW VERSION	P1.1		
SW VERSION	MIUI14		
IMEI	867866060030240 867866060047483 867866060047491		
I/O PORTS	Refer to user's manual		
CABLE SUPPLIED	USB cable1: non-shielded cable, with w/o ferrite core, 1.0 meter USB cable2: non-shielded cable, with w/o ferrite core, 1.0 meter		



EXTREME TEMPERATURE	0-40 °C
EXTREME VOLTAGE	3.5V - 4.2V

NOTE:

1. For a more detailed features description, please refer to the manufacturer's specifications or the user's manual.

The EUT incorporates a SISO function. Physically, the EUT provides two completed transmitter and one receiver.

MODULATION MODE	TX FUNCTION
GSM/GPRS/EDGE	2TX/2RX
WCDMA	2TX/2RX
LTE	2TX/2RX

2. For the test results, the EUT had been tested with all conditions. But only the worst case was shown in test report.



2.2 CONFIGURATION OF SYSTEM UNDER TEST

FOR RADIATION EMISSION TEST

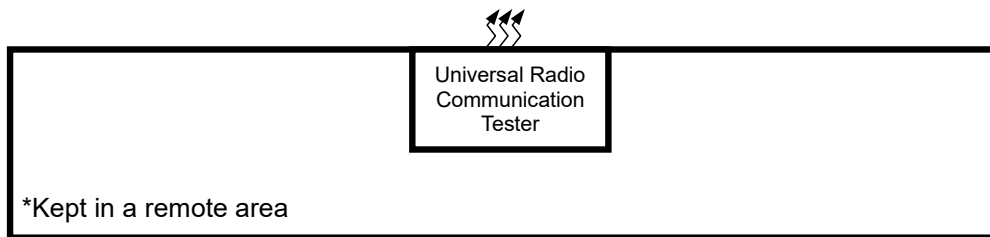
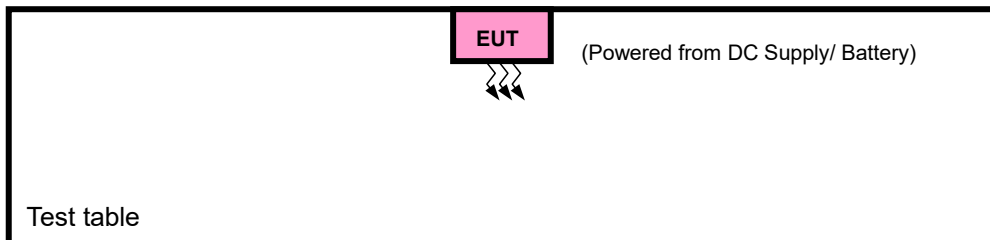
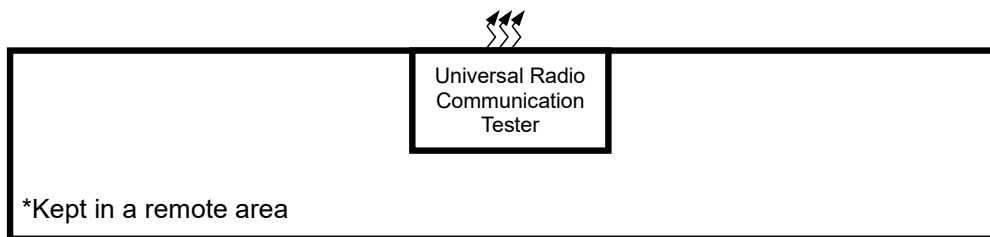
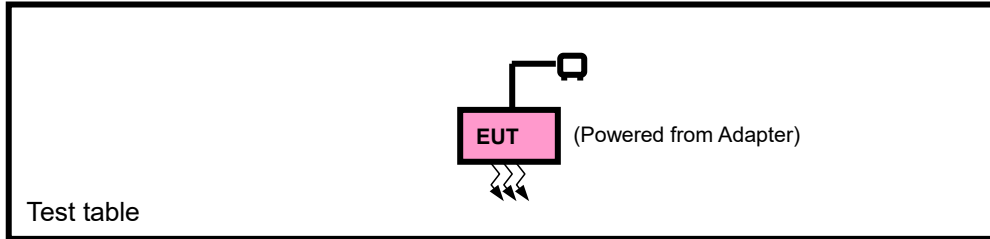



2.3 DESCRIPTION OF SUPPORT UNITS

The EUT has been tested as an independent unit together with other necessary accessories or support units. The following support units or accessories were used to form a representative test configuration during the tests.

NO.	PRODUCT	BRAND	MODEL NO.	SERIAL NO.	FCC ID
1	DC source	Kikusui/JP	PMX18-5A	0000001	N/A

NO.	SIGNAL CABLE DESCRIPTION OF THE ABOVE SUPPORT UNITS
1	DC Line: Unshielded, Detachable 1.0m

2.4 TEST ITEM AND TEST CONFIGURATION

Pre-Scan has been conducted to determine the worst-case mode from all possible combinations between available modulations, data rates, XYZ axis and antenna ports. The worst case in EIRP and radiated emission was found when positioned on X-plane for GSM/EDGE/ LTE. Following channel(s) was (were) selected for the final test as listed below:

EUT CONFIGURE MODE	DESCRIPTION
A	EUT + Adapter with GSM or WCDMA or LTE link
B	EUT + DC source with GSM or WCDMA or LTE link

GSM MODE

EUT CONFIGURE MODE	TEST ITEM	AVAILABLE CHANNEL	TESTED CHANNEL	MODE
A	EIRP	512 to 810	512, 661, 810	GSM,EDGE
B	FREQUENCY STABILITY	512 to 810	512, 661, 810	GSM,EDGE
A	OCCUPIED BANDWIDTH	512 to 810	512, 661, 810	GSM,EDGE
A	PEAK TO AVERAGE RATIO	512 to 810	512, 661, 810	GSM,EDGE
A	BAND EDGE	512 to 810	512, 810	GSM,EDGE
A	CONDUCTED EMISSION	512 to 810	512, 661, 810	GSM,EDGE
A	RADIATED EMISSION	512 to 810	512, 661, 810	GSM,EDGE



**BUREAU
VERITAS**

Test Report No.: W7L-P23030003RF05

WCDMA

EUT CONFIGURE MODE	TEST ITEM	AVAILABLE CHANNEL	TESTED CHANNEL	MODE
A	EIRP	9262 to 9538	9262, 9400, 9538	WCDMA
B	FREQUENCY STABILITY	9262 to 9538	9262, 9400, 9538	WCDMA
A	OCCUPIED BANDWIDTH	9262 to 9538	9262, 9400, 9538	WCDMA
A	PEAK TO AVERAGE RATIO	9262 to 9538	9262, 9400, 9538	WCDMA
A	BAND EDGE	9262 to 9538	9262, 9538	WCDMA
A	CONDCUDED EMISSION	9262 to 9538	9262, 9400, 9538	WCDMA
A	RADIATED EMISSION	9262 to 9538	9262, 9400, 9538	WCDMA

LTE BAND 2 MODE

EUT CONFIGURE MODE	TEST ITEM	AVAILABLE CHANNEL	TESTED CHANNEL	CHANNEL BANDWIDTH	MODULATION	MODE
A	EIRP	18607 to 19193	18607, 18900, 19193	1.4MHz	QPSK,16QAM, 64QAM	1 RB / 0 RB Offset
		18615 to 19185	18615, 18900, 19185	3MHz	QPSK,16QAM, 64QAM	1 RB / 0 RB Offset
		18625 to 19175	18625, 18900, 19175	5MHz	QPSK,16QAM, 64QAM	1 RB / 0 RB Offset
		18650 to 19150	18650, 18900, 19150	10MHz	QPSK,16QAM, 64QAM	1 RB / 0 RB Offset
		18675 to 19125	18675, 18900, 19125	15MHz	QPSK,16QAM, 64QAM	1 RB / 0 RB Offset
		18700 to 19100	18700, 18900, 19100	20MHz	QPSK,16QAM, 64QAM	1 RB / 0 RB Offset
B	FREQUENCY STABILITY	18700 to 19100	18700, 19100	20MHz	QPSK	100 RB / 0 RB Offset
A	OCCUPIED BANDWIDTH	18607 to 19193	18607, 18900, 19193	1.4MHz	QPSK,16QAM, 64QAM	6 RB / 0 RB Offset
		18615 to 19185	18615, 18900, 19185	3MHz	QPSK,16QAM, 64QAM	15 RB / 0 RB Offset
		18625 to 19175	18625, 18900, 19175	5MHz	QPSK,16QAM, 64QAM	25 RB / 0 RB Offset
		18650 to 19150	18650, 18900, 19150	10MHz	QPSK,16QAM, 64QAM	50 RB / 0 RB Offset
		18675 to 19125	18675, 18900, 19125	15MHz	QPSK,16QAM, 64QAM	75 RB / 0 RB Offset
A	PEAK TO AVERAGE RATIO	18700 to 19100	18700, 18900, 19100	20MHz	QPSK,16QAM, 64QAM	1 RB / 0 RB Offset 100 RB / 0 RB Offset



A	BAND EDGE	18607 to 19193	18607	1.4MHz	QPSK,16QAM, 64QAM	1 RB / 0 RB Offset		
			19193	1.4MHz	QPSK,16QAM, 64QAM	6 RB / 0 RB Offset		
		18615 to 19185	18615	3MHz	QPSK,16QAM, 64QAM	1 RB / 5 RB Offset		
			19185	3MHz	QPSK,16QAM, 64QAM	6 RB / 0 RB Offset		
		18625 to 19175	18625	5MHz	QPSK,16QAM, 64QAM	1 RB / 0 RB Offset		
			19175	5MHz	QPSK,16QAM, 64QAM	15 RB / 0 RB Offset		
		18650 to 19150	18650	10MHz	QPSK,16QAM, 64QAM	1 RB / 14 RB Offset		
			19150	10MHz	QPSK,16QAM, 64QAM	15 RB / 0 RB Offset		
		18675 to 19125	18675	15MHz	QPSK,16QAM, 64QAM	1 RB / 0 RB Offset		
			19125	15MHz	QPSK,16QAM, 64QAM	25 RB / 0 RB Offset		
		18700 to 19100	18700	20MHz	QPSK,16QAM, 64QAM	1 RB / 24 RB Offset		
			19100	20MHz	QPSK,16QAM, 64QAM	25 RB / 0 RB Offset		
		A	CONDCUDED EMISSION	18607 to 19193	18607, 18900, 19193	1.4MHz	QPSK	1 RB / 0 RB Offset
				18615 to 19185	18615, 18900, 19185	3MHz	QPSK	1 RB / 0 RB Offset
				18625 to 19175	18625, 18900, 19175	5MHz	QPSK	1 RB / 0 RB Offset
				18650 to 19150	18650, 18900, 19150	10MHz	QPSK	1 RB / 0 RB Offset
				18675 to 19125	18675, 18900, 19125	15MHz	QPSK	1 RB / 0 RB Offset
				18700 to 19100	18700, 18900, 19100	20MHz	QPSK	1 RB / 0 RB Offset
A	RADIATED EMISSION	18607 to 19193	18900	1.4MHz	QPSK	1 RB / 0 RB Offset		
		18615 to 19185	18900	3MHz	QPSK	1 RB / 0 RB Offset		
		18625 to 19175	18900	5MHz	QPSK	1 RB / 0 RB Offset		
		18650 to 19150	18900	10MHz	QPSK	1 RB / 0 RB Offset		
		18675 to 19125	18675, 18900, 19125	15MHz	QPSK	1 RB / 0 RB Offset		
		18700 to 19100	18900	20MHz	QPSK	1 RB / 0 RB Offset		

Note: This device was tested under all bandwidths, RB configurations and modulations. The worst case was found in QPSK modulation.



TEST CONDITION:

TEST ITEM	ENVIRONMENTAL CONDITIONS	INPUT POWER	TESTED BY
EIRP	25deg. C, 57%RH	DC 5V/9V/10V/12V By Adapter	Jace Hu
FREQUENCY STABILITY	23deg. C, 61%RH	DC 3.5/3.8/4.2 By DC Source	James Fu
OCCUPIED BANDWIDTH	23deg. C, 61%RH	DC 5V/9V/10V/12V By Adapter	James Fu
PEAK TO AVERAGE RATIO	23deg. C, 61%RH	DC 5V/9V/10V/12V By Adapter	James Fu
BAND EDGE	23deg. C, 61%RH	DC 5V/9V/10V/12V By Adapter	James Fu
CONDCUDED EMISSION	23deg. C, 61%RH	DC 5V/9V/10V/12V By Adapter	James Fu
RADIATED EMISSION	23deg. C, 70%RH	DC 5V/9V/10V/12V By Adapter	Jace Hu

2.5 EUT OPERATING CONDITIONS

The EUT makes a call to the communication simulator. The communication simulator station system controlled a EUT to export maximum output power under transmission mode and specific channel frequency

2.6 GENERAL DESCRIPTION OF APPLIED STANDARDS

The EUT is a RF product. According to the specifications of the manufacturer, it must comply with the requirements of the following standards:

FCC 47 CFR Part 2

FCC 47 CFR Part 24

KDB 971168 D01 Power Meas License Digital Systems v03r01

ANSI/TIA/EIA-603-D

ANSI/TIA/EIA-603-E

ANSI C63.26-2015

NOTE: All test items have been performed and recorded as per the above standards.



3 TEST TYPES AND RESULTS

3.1 OUTPUT POWER MEASUREMENT

3.1.1 LIMITS OF OUTPUT POWER MEASUREMENT

Mobile and portable stations are limited to 2 watts EIRP.

3.1.2 TEST PROCEDURES

EIRP MEASUREMENT:

Per KDB 971168 D01 Power Meas License Digital Systems v03r01 or subclause 5.2.5.5 of ANSI C63.26-2015, the relevant equation for determining the ERP or EIRP from the conducted RF output power measured using the guidance provided above is:

$$\text{ERP or EIRP} = P_{\text{Meas}} + G_{\text{T}} - L_{\text{C}}$$

Where:

ERP or EIRP = effective radiated power or equivalent isotropically radiated power, respectively

(expressed in the same units as P_{Meas} , typically dBW or dBm);

P_{Meas} = measured transmitter output power or PSD, in dBm or dBW;

G_{T} = gain of the transmitting antenna, in dBd (ERP) or dBi (EIRP);

L_{C} = signal attenuation in the connecting cable between the transmitter and antenna, in dB.

CONDUCTED POWER MEASUREMENT:

The EUT was set up for the maximum power with WCDMA link data modulation and link up with simulator. Set the EUT to transmit under low, middle and high channel and record the power level shown on simulator.



3.1.3 TEST SETUP

EIRP / ERP Measurement:

CONDUCTED POWER MEASUREMENT:

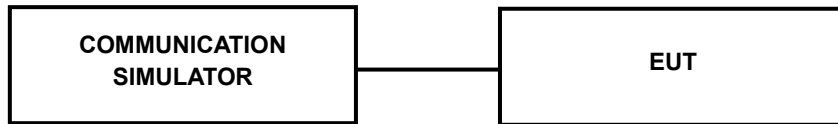

3.1.4 TEST RESULTS

CONDUCTED OUTPUT POWER (dBm)

Ant 0

Band	GSM1900		
Channel	512	661	810
Frequency	1850.2	1880	1909.8
GSM	29.51	29.33	29.12
GPRS (GMSK, 1Tx-slot)	29.49	29.30	29.09
GPRS (GMSK, 2Tx-slot)	28.77	28.97	28.40
GPRS (GMSK, 3Tx-slot)	26.91	26.74	26.59
GPRS (GMSK, 4Tx-slot)	25.91	25.77	25.62
EDGE (8PSK, 1Tx-slot)	25.75	25.83	25.75
EDGE (8PSK, 2Tx-slot)	24.71	24.70	24.71
EDGE (8PSK, 3Tx-slot)	22.51	22.57	22.51
EDGE (8PSK, 4Tx-slot)	21.26	21.34	21.35

Band	WCDMA II		
Channel	9262	9400	9538
Frequency	1852.4	1880	1907.6
RMC 12.2K	24.10	24.08	24.09
HSDPA Subtest-1	23.13	23.02	22.99
HSDPA Subtest-2	23.13	23.08	23.02
HSDPA Subtest-3	22.18	22.05	21.98
HSDPA Subtest-4	22.15	22.03	21.99
DC-HSDPA Subtest-1	23.09	23.09	22.93
DC-HSDPA Subtest-2	23.13	23.03	22.95
DC-HSDPA Subtest-3	22.16	22.06	21.95
DC-HSDPA Subtest-4	22.14	22.06	21.93
HSUPA Subtest-1	21.18	21.15	21.16
HSUPA Subtest-2	21.03	21.03	21.06
HSUPA Subtest-3	22.13	22.10	22.12
HSUPA Subtest-4	20.65	20.63	20.62
HSUPA Subtest-5	22.16	22.15	22.13



**BUREAU
VERITAS**

Test Report No.: W7L-P23030003RF05

LTE BAND 2

Band/BW	Modulation	RB Size	RB Offset	Low CH 18607	Mid CH 18900	High CH 19193
				Frequency 1850.7 MHz	Frequency 1880 MHz	Frequency 1909.3 MHz
2/ 1.4	QPSK	1	0	23.90	23.87	23.85
		1	2	24.13	23.99	24.07
		1	5	23.78	23.72	23.70
		3	0	24.11	24.01	24.08
		3	1	24.13	24.02	23.95
		3	3	24.08	23.98	24.03
		6	0	23.15	23.04	22.99
	16QAM	1	0	23.02	22.94	22.95
		1	2	23.26	23.12	23.19
		1	5	22.93	22.80	22.86
		3	0	23.06	22.98	23.01
		3	1	23.03	22.99	22.99
		3	3	23.06	23.04	23.04
		6	0	22.07	22.00	22.01
	64QAM	1	0	22.05	22.03	22.07
		1	2	22.31	22.31	22.22
		1	5	22.04	21.94	22.02
		3	0	22.08	22.02	21.98
		3	1	22.04	22.05	21.93
		3	3	22.09	22.00	22.07
		6	0	21.13	21.06	21.06



**BUREAU
VERITAS**

Test Report No.: W7L-P23030003RF05

Band/BW	Modulation	RB Size	RB Offset	Low CH 18615	Mid CH 18900	High CH 19185
				Frequency 1851.5 MHz	Frequency 1880 MHz	Frequency 1908.5 MHz
2/3	QPSK	1	0	23.89	23.86	23.88
		1	7	24.14	23.97	24.07
		1	14	23.75	23.71	23.74
		8	0	23.13	23.04	23.05
		8	3	23.06	23.03	22.98
		8	7	23.09	23.01	23.08
		15	0	23.10	23.08	22.96
	16QAM	1	0	23.00	22.96	22.98
		1	7	23.20	23.18	23.16
		1	14	22.96	22.80	22.85
		8	0	22.02	21.97	21.98
		8	3	22.05	21.98	21.98
		8	7	22.03	22.04	22.03
		15	0	22.07	21.95	22.01
	64QAM	1	0	22.05	22.03	22.07
		1	7	22.31	22.31	22.21
		1	14	21.98	22.01	22.02
		8	0	21.12	21.03	20.98
		8	3	21.02	21.06	20.97
		8	7	21.10	21.03	21.00
		15	0	21.11	21.09	21.08



**BUREAU
VERITAS**

Test Report No.: W7L-P23030003RF05

Band/BW	Modulation	RB Size	RB Offset	Low CH 18625	Mid CH 18900	High CH 19175
				Frequency 1852.5 MHz	Frequency 1880 MHz	Frequency 1907.5 MHz
2 / 5	QPSK	1	0	23.89	23.92	23.84
		1	12	24.09	24.00	24.07
		1	24	23.74	23.72	23.70
		12	0	23.10	23.04	23.08
		12	6	23.06	23.02	22.97
		12	13	23.05	23.05	23.07
		25	0	23.12	23.05	22.93
	16QAM	1	0	22.99	23.00	22.98
		1	12	23.23	23.15	23.17
		1	24	22.96	22.80	22.86
		12	0	22.02	21.99	22.01
		12	6	22.08	21.94	22.02
		12	13	22.08	22.02	22.00
		25	0	22.07	21.94	22.04
	64QAM	1	0	22.11	22.06	22.01
		1	12	22.34	22.25	22.21
		1	24	22.05	21.96	22.02
		12	0	21.11	21.06	20.99
		12	6	21.08	20.99	20.98
		12	13	21.06	21.04	21.03
		25	0	21.15	21.03	21.10



**BUREAU
VERITAS**

Test Report No.: W7L-P23030003RF05

Band/BW	Modulation	RB Size	RB Offset	Low CH 18650	Mid CH 18900	High CH 19150
				Frequency 1855 MHz	Frequency 1880 MHz	Frequency 1905 MHz
2/ 10	QPSK	1	0	23.94	23.90	23.82
		1	24	24.12	24.02	24.03
		1	49	23.78	23.78	23.71
		25	0	23.11	23.04	23.09
		25	12	23.13	23.02	22.98
		25	25	23.05	22.99	23.07
		50	0	23.15	23.06	22.98
	16QAM	1	0	23.04	23.00	22.94
		1	24	23.24	23.15	23.19
		1	49	22.92	22.86	22.84
		25	0	22.08	21.95	22.05
		25	12	22.03	21.96	21.99
		25	25	22.07	22.03	22.03
		50	0	22.12	21.97	21.98
	64QAM	1	0	22.06	22.05	22.05
		1	24	22.37	22.26	22.22
		1	49	22.00	21.94	22.02
		25	0	21.15	21.06	20.98
		25	12	21.03	20.99	20.93
		25	25	21.12	21.07	21.04
		50	0	21.15	21.03	21.10



**BUREAU
VERITAS**

Test Report No.: W7L-P23030003RF05

Band/BW	Modulation	RB Size	RB Offset	Low CH 18675	Mid CH 18900	High CH 19125
				Frequency 1857.5 MHz	Frequency 1880 MHz	Frequency 1902.5 MHz
2/ 15	QPSK	1	0	23.87	23.90	23.85
		1	37	24.14	23.97	24.08
		1	74	23.72	23.75	23.70
		36	0	23.14	23.03	23.08
		36	19	23.12	22.97	22.98
		36	39	23.07	22.98	23.07
		75	0	23.15	23.08	22.93
	16QAM	1	0	23.00	22.93	22.94
		1	37	23.25	23.14	23.19
		1	74	22.96	22.81	22.82
		36	0	22.04	21.95	22.04
		36	19	22.09	21.92	22.03
		36	39	22.02	22.05	22.00
		75	0	22.11	21.94	22.05
	64QAM	1	0	22.06	22.03	22.08
		1	37	22.38	22.31	22.22
		1	74	21.98	21.95	22.02
		36	0	21.15	21.04	21.03
		36	19	21.07	21.06	20.93
		36	39	21.10	21.03	21.06
		75	0	21.16	21.05	21.09



**BUREAU
VERITAS**

Test Report No.: W7L-P23030003RF05

Band/BW	Modulation	RB Size	RB Offset	Low CH 18700	Mid CH 18900	High CH 19100
				Frequency 1860 MHz	Frequency 1880 MHz	Frequency 1900 MHz
2/ 20	QPSK	1	0	23.95	23.94	23.90
		1	50	24.16	24.05	24.09
		1	99	23.80	23.79	23.75
		50	0	23.17	23.09	23.10
		50	25	23.14	23.04	23.03
		50	50	23.13	23.06	23.09
		100	0	23.16	23.10	23.01
	16QAM	1	0	23.07	23.01	23.00
		1	50	23.28	23.20	23.21
		1	99	22.98	22.88	22.87
		50	0	22.10	22.03	22.06
		50	25	22.11	22.00	22.04
		50	50	22.10	22.09	22.05
		100	0	22.13	22.02	22.06
	64QAM	1	0	22.12	22.08	22.09
		1	50	22.39	22.33	22.27
		1	99	22.06	22.02	22.04
		50	0	21.16	21.08	21.06
		50	25	21.10	21.07	20.99
		50	50	21.14	21.08	21.08
		100	0	21.17	21.11	21.11



Ant 4

Band	GSM1900		
Channel	512	661	810
Frequency	1850.2	1880	1909.8
GSM	29.86	29.44	29.13
GPRS (GMSK, 1Tx-slot)	29.85	29.47	29.14
GPRS (GMSK, 2Tx-slot)	29.14	28.76	28.46
GPRS (GMSK, 3Tx-slot)	27.30	26.96	26.68
GPRS (GMSK, 4Tx-slot)	26.30	26.00	25.72
EDGE (8PSK, 1Tx-slot)	25.67	25.81	25.80
EDGE (8PSK, 2Tx-slot)	24.63	24.74	24.77
EDGE (8PSK, 3Tx-slot)	22.19	22.49	22.64
EDGE (8PSK, 4Tx-slot)	21.11	21.28	21.28

Band	WCDMA II		
Channel	9262	9400	9538
Frequency	1852.4	1880	1907.6
RMC 12.2K	24.07	24.12	24.14
HSDPA Subtest-1	23.01	23.11	23.16
HSDPA Subtest-2	23.07	23.13	23.14
HSDPA Subtest-3	22.15	22.26	22.21
HSDPA Subtest-4	22.12	22.20	22.23
DC-HSDPA Subtest-1	23.00	23.13	23.12
DC-HSDPA Subtest-2	23.03	23.06	23.13
DC-HSDPA Subtest-3	22.13	22.26	22.25
DC-HSDPA Subtest-4	22.16	22.22	22.26
HSUPA Subtest-1	21.22	21.25	21.24
HSUPA Subtest-2	21.15	21.27	21.26
HSUPA Subtest-3	22.25	22.29	22.31
HSUPA Subtest-4	20.78	20.85	20.91
HSUPA Subtest-5	22.15	22.18	22.15



**BUREAU
VERITAS**

Test Report No.: W7L-P23030003RF05

LTE BAND 2

Band/BW	Modulation	RB Size	RB Offset	Low CH 18607	Mid CH 18900	High CH 19193
				Frequency 1850.7 MHz	Frequency 1880 MHz	Frequency 1909.3 MHz
2/ 1.4	QPSK	1	0	23.70	23.76	23.75
		1	2	23.93	23.88	23.97
		1	5	23.72	23.65	23.74
		3	0	23.91	23.88	23.96
		3	1	23.93	23.93	23.89
		3	3	23.84	23.83	23.89
		6	0	22.95	22.85	22.97
	16QAM	1	0	22.84	22.85	22.87
		1	2	23.04	22.99	23.07
		1	5	22.76	22.72	22.79
		3	0	22.84	22.85	22.89
		3	1	22.86	22.91	22.92
		3	3	22.82	22.89	22.90
		6	0	21.86	21.88	21.90
	64QAM	1	0	21.93	22.00	22.05
		1	2	22.12	22.21	22.13
		1	5	22.03	22.02	22.11
		3	0	21.87	21.90	21.87
		3	1	21.85	21.95	21.84
		3	3	21.85	21.85	21.93
		6	0	20.88	20.86	20.88



**BUREAU
VERITAS**

Test Report No.: W7L-P23030003RF05

Band/BW	Modulation	RB Size	RB Offset	Low CH 18615	Mid CH 18900	High CH 19185
				Frequency 1851.5 MHz	Frequency 1880 MHz	Frequency 1908.5 MHz
2 / 3	QPSK	1	0	23.67	23.73	23.76
		1	7	23.92	23.84	23.95
		1	14	23.67	23.62	23.76
		8	0	22.91	22.89	22.91
		8	3	22.84	22.92	22.90
		8	7	22.83	22.84	22.92
		15	0	22.88	22.87	22.92
	16QAM	1	0	22.80	22.85	22.88
		1	7	22.96	23.03	23.02
		1	14	22.77	22.70	22.76
		8	0	21.78	21.82	21.84
		8	3	21.86	21.88	21.89
		8	7	21.77	21.87	21.87
		15	0	21.84	21.81	21.88
	64QAM	1	0	21.91	21.98	22.03
		1	7	22.10	22.19	22.10
		1	14	21.95	22.07	22.09
		8	0	20.89	20.89	20.85
		8	3	20.81	20.94	20.86
		8	7	20.84	20.86	20.84
		15	0	20.84	20.87	20.88



**BUREAU
VERITAS**

Test Report No.: W7L-P23030003RF05

Band/BW	Modulation	RB Size	RB Offset	Low CH 18625	Mid CH 18900	High CH 19175
				Frequency 1852.5 MHz	Frequency 1880 MHz	Frequency 1907.5 MHz
2 / 5	QPSK	1	0	23.66	23.78	23.71
		1	12	23.86	23.86	23.94
		1	24	23.65	23.62	23.71
		12	0	22.87	22.88	22.93
		12	6	22.83	22.90	22.88
		12	13	22.78	22.87	22.90
		25	0	22.89	22.83	22.88
	16QAM	1	0	22.78	22.88	22.87
		1	12	22.98	22.99	23.02
		1	24	22.76	22.69	22.76
		12	0	21.77	21.83	21.86
		12	6	21.88	21.83	21.92
		12	13	21.81	21.84	21.83
		25	0	21.83	21.79	21.90
	64QAM	1	0	21.96	22.00	21.96
		1	12	22.12	22.12	22.09
		1	24	22.01	22.01	22.08
		12	0	20.87	20.91	20.85
		12	6	20.86	20.86	20.86
		12	13	20.79	20.86	20.86
		25	0	20.87	20.80	20.89



**BUREAU
VERITAS**

Test Report No.: W7L-P23030003RF05

Band/BW	Modulation	RB Size	RB Offset	Low CH 18650	Mid CH 18900	High CH 19150
				Frequency 1855 MHz	Frequency 1880 MHz	Frequency 1905 MHz
2/ 10	QPSK	1	0	23.75	23.80	23.73
		1	24	23.93	23.92	23.94
		1	49	23.73	23.72	23.76
		25	0	22.92	22.92	22.98
		25	12	22.94	22.94	22.93
		25	25	22.82	22.85	22.94
		50	0	22.96	22.88	22.97
	16QAM	1	0	22.87	22.92	22.87
		1	24	23.03	23.03	23.08
		1	49	22.76	22.79	22.78
		25	0	21.87	21.83	21.94
		25	12	21.87	21.89	21.93
		25	25	21.84	21.89	21.90
		50	0	21.92	21.86	21.88
	64QAM	1	0	21.95	22.03	22.04
		1	24	22.19	22.17	22.14
		1	49	22.00	22.03	22.12
		25	0	20.95	20.95	20.88
		25	12	20.85	20.90	20.85
		25	25	20.89	20.93	20.91
		50	0	20.91	20.84	20.93



**BUREAU
VERITAS**

Test Report No.: W7L-P23030003RF05

Band/BW	Modulation	RB Size	RB Offset	Low CH 18675	Mid CH 18900	High CH 19125
				Frequency 1857.5 MHz	Frequency 1880 MHz	Frequency 1902.5 MHz
2/ 15	QPSK	1	0	23.63	23.75	23.71
		1	37	23.90	23.82	23.94
		1	74	23.62	23.64	23.70
		36	0	22.90	22.86	22.92
		36	19	22.88	22.84	22.88
		36	39	22.79	22.79	22.89
		75	0	22.91	22.85	22.87
	16QAM	1	0	22.78	22.80	22.82
		1	37	22.99	22.97	23.03
		1	74	22.75	22.69	22.71
		36	0	21.78	21.78	21.88
		36	19	21.88	21.80	21.92
		36	39	21.74	21.86	21.82
		75	0	21.86	21.78	21.90
	64QAM	1	0	21.90	21.96	22.02
		1	37	22.15	22.17	22.09
		1	74	21.93	21.99	22.07
		36	0	20.90	20.88	20.88
		36	19	20.84	20.92	20.80
		36	39	20.82	20.84	20.88
		75	0	20.87	20.81	20.87



**BUREAU
VERITAS**

Test Report No.: W7L-P23030003RF05

Band/BW	Modulation	RB Size	RB Offset	Low CH 18700	Mid CH 18900	High CH 19100
				Frequency 1860 MHz	Frequency 1880 MHz	Frequency 1900 MHz
2/ 20	QPSK	1	0	23.78	23.86	23.83
		1	50	23.99	23.97	24.02
		1	99	23.77	23.75	23.82
		50	0	23.00	22.99	23.01
		50	25	22.97	22.98	23.00
		50	50	22.92	22.94	22.98
		100	0	22.99	22.94	23.02
	16QAM	1	0	22.92	22.95	22.95
		1	50	23.09	23.10	23.12
		1	99	22.84	22.83	22.83
		50	0	21.91	21.93	21.97
		50	25	21.97	21.95	22.00
		50	50	21.89	21.97	21.94
		100	0	21.95	21.93	21.98
	64QAM	1	0	22.03	22.08	22.10
		1	50	22.23	22.26	22.21
		1	99	22.08	22.13	22.16
		50	0	20.98	20.99	20.98
		50	25	20.94	21.00	20.93
		50	50	20.93	20.96	20.97
		100	0	20.95	20.94	20.96



**BUREAU
VERITAS**

Test Report No.: W7L-P23030003RF05

EIRP POWER (dBm)

Ant 0

GSM

Channel	Frequency (MHz)	Conducted Power (dBm)	G _T -L _C (dB)	EIRP (dBm)	EIRP (mW)	Limit (W)
512	1850.2	29.51	-1.88	27.63	579.43	2
661	1880.0	29.33	-1.88	27.45	555.9	2
810	1909.8	29.12	-1.88	27.24	529.66	2

EDGE

Channel	Frequency (MHz)	Conducted Power (dBm)	G _T -L _C (dB)	EIRP (dBm)	EIRP (mW)	Limit (W)
512	1850.2	25.75	-1.88	23.87	243.78	2
661	1880.0	25.83	-1.88	23.95	248.31	2
810	1909.8	25.75	-1.88	23.87	243.78	2

WCDMA

Channel	Frequency (MHz)	Conducted Power (dBm)	G _T -L _C (dB)	EIRP (dBm)	EIRP (mW)	Limit (W)
9262	1852.4	24.1	-1.88	22.22	166.72	2
9400	1880	24.08	-1.88	22.2	165.96	2
9538	1907.6	24.09	-1.88	22.21	166.34	2



LTE BAND 2

CHANNEL BANDWIDTH: 1.4MHz QPSK

Channel	Frequency (MHz)	Conducted Power (dBm)	G _{T-Lc} (dB)	EIRP (dBm)	EIRP (mW)	Limit (W)
18607	1850.7	24.13	-1.88	22.25	167.88	2
18900	1880.0	24.02	-1.88	22.14	163.68	2
19193	1909.3	24.08	-1.88	22.2	165.96	2

CHANNEL BANDWIDTH: 1.4MHz 16QAM

Channel	Frequency (MHz)	Conducted Power (dBm)	G _{T-Lc} (dB)	EIRP (dBm)	EIRP (mW)	Limit (W)
18607	1850.7	23.26	-1.88	21.38	137.4	2
18900	1880.0	23.12	-1.88	21.24	133.05	2
19193	1909.3	23.19	-1.88	21.31	135.21	2

CHANNEL BANDWIDTH: 1.4MHz 64QAM

Channel	Frequency (MHz)	Conducted Power (dBm)	G _{T-Lc} (dB)	EIRP (dBm)	EIRP (mW)	Limit (W)
18607	1850.7	22.31	-1.88	20.43	110.41	2
18900	1880.0	22.31	-1.88	20.43	110.41	2
19193	1908.3	22.22	-1.88	20.34	108.14	2



CHANNEL BANDWIDTH: 3MHz QPSK

Channel	Frequency (MHz)	Conducted Power (dBm)	G _{T-Lc} (dB)	EIRP (dBm)	EIRP (mW)	Limit (W)
18615	1851.5	24.14	-1.88	22.26	168.27	2
18900	1880.0	23.97	-1.88	22.09	161.81	2
19185	1908.5	24.07	-1.88	22.19	165.58	2

CHANNEL BANDWIDTH: 3MHz 16QAM

Channel	Frequency (MHz)	Conducted Power (dBm)	G _{T-Lc} (dB)	EIRP (dBm)	EIRP (mW)	Limit (W)
18615	1851.5	23.2	-1.88	21.32	135.52	2
18900	1880.0	23.18	-1.88	21.3	134.9	2
19185	1908.5	23.16	-1.88	21.28	134.28	2

CHANNEL BANDWIDTH: 3MHz 64QAM

Channel	Frequency (MHz)	Conducted Power (dBm)	G _{T-Lc} (dB)	EIRP (dBm)	EIRP (mW)	Limit (W)
18615	1851.5	22.31	-1.88	20.43	110.41	2
18900	1880.0	22.31	-1.88	20.43	110.41	2
19185	1908.5	22.21	-1.88	20.33	107.89	2



BUREAU
VERITAS

Test Report No.: W7L-P23030003RF05

CHANNEL BANDWIDTH: 5MHz QPSK

Channel	Frequency (MHz)	Conducted Power (dBm)	G _{T-Lc} (dB)	EIRP (dBm)	EIRP (mW)	Limit (W)
18625	1852.5	24.09	-1.88	22.21	166.34	2
18900	1880.0	24	-1.88	22.12	162.93	2
19175	1907.5	24.07	-1.88	22.19	165.58	2

CHANNEL BANDWIDTH: 5MHz 16QAM

Channel	Frequency (MHz)	Conducted Power (dBm)	G _{T-Lc} (dB)	EIRP (dBm)	EIRP (mW)	Limit (W)
18625	1852.5	23.23	-1.88	21.35	136.46	2
18900	1880.0	23.15	-1.88	21.27	133.97	2
19175	1907.5	23.17	-1.88	21.29	134.59	2

CHANNEL BANDWIDTH: 5MHz 64QAM

Channel	Frequency (MHz)	Conducted Power (dBm)	G _{T-Lc} (dB)	EIRP (dBm)	EIRP (mW)	Limit (W)
18625	1852.5	22.34	-1.88	20.46	111.17	2
18900	1880.0	22.25	-1.88	20.37	108.89	2
19175	1907.5	22.21	-1.88	20.33	107.89	2



CHANNEL BANDWIDTH: 10MHz QPSK

Channel	Frequency (MHz)	Conducted Power (dBm)	G _{T-Lc} (dB)	EIRP (dBm)	EIRP (mW)	Limit (W)
18650	1855.0	24.12	-1.88	22.24	167.49	2
18900	1880.0	24.02	-1.88	22.14	163.68	2
19150	1905.0	24.03	-1.88	22.15	164.06	2

CHANNEL BANDWIDTH: 10MHz 16QAM

Channel	Frequency (MHz)	Conducted Power (dBm)	G _{T-Lc} (dB)	EIRP (dBm)	EIRP (mW)	Limit (W)
18650	1855.0	23.24	-1.88	21.36	136.77	2
18900	1880.0	23.15	-1.88	21.27	133.97	2
19150	1905.0	23.19	-1.88	21.31	135.21	2

CHANNEL BANDWIDTH: 10MHz 64QAM

Channel	Frequency (MHz)	Conducted Power (dBm)	G _{T-Lc} (dB)	EIRP (dBm)	EIRP (mW)	Limit (W)
18650	1855.0	22.37	-1.88	20.49	111.94	2
18900	1880.0	22.26	-1.88	20.38	109.14	2
19150	1905.0	22.22	-1.88	20.34	108.14	2



CHANNEL BANDWIDTH: 15MHz QPSK

Channel	Frequency (MHz)	Conducted Power (dBm)	G _{T-Lc} (dB)	EIRP (dBm)	EIRP (mW)	Limit (W)
18675	1857.5	24.14	-1.88	22.26	168.27	2
18900	1880.0	23.97	-1.88	22.09	161.81	2
19125	1902.5	24.08	-1.88	22.2	165.96	2

CHANNEL BANDWIDTH: 15MHz 16QAM

Channel	Frequency (MHz)	Conducted Power (dBm)	G _{T-Lc} (dB)	EIRP (dBm)	EIRP (mW)	Limit (W)
18675	1857.5	23.25	-1.88	21.37	137.09	2
18900	1880.0	23.14	-1.88	21.26	133.66	2
19125	1902.5	23.19	-1.88	21.31	135.21	2

CHANNEL BANDWIDTH: 15MHz 64QAM

Channel	Frequency (MHz)	Conducted Power (dBm)	G _{T-Lc} (dB)	EIRP (dBm)	EIRP (mW)	Limit (W)
18675	1857.5	22.38	-1.88	20.5	112.2	2
18900	1880.0	22.31	-1.88	20.43	110.41	2
19125	1902.5	22.22	-1.88	20.34	108.14	2



CHANNEL BANDWIDTH: 20MHz QPSK

Channel	Frequency (MHz)	Conducted Power (dBm)	G _{T-Lc} (dB)	EIRP (dBm)	EIRP (mW)	Limit (W)
18700	1860	24.16	-1.88	22.28	169.04	2
18900	1880	24.05	-1.88	22.17	164.82	2
19100	1900	24.09	-1.88	22.21	166.34	2

CHANNEL BANDWIDTH: 20MHz 16QAM

Channel	Frequency (MHz)	Conducted Power (dBm)	G _{T-Lc} (dB)	EIRP (dBm)	EIRP (mW)	Limit (W)
18700	1860	23.28	-1.88	21.4	138.04	2
18900	1880	23.2	-1.88	21.32	135.52	2
19100	1900	23.21	-1.88	21.33	135.83	2

CHANNEL BANDWIDTH: 20MHz 64QAM

Channel	Frequency (MHz)	Conducted Power (dBm)	G _{T-Lc} (dB)	EIRP (dBm)	EIRP (mW)	Limit (W)
18700	1860	22.39	-1.88	20.51	112.46	2
18900	1880	22.33	-1.88	20.45	110.92	2
19100	1900	22.27	-1.88	20.39	109.4	2



**BUREAU
VERITAS**

Test Report No.: W7L-P23030003RF05

Ant 4

GSM

Channel	Frequency (MHz)	Conducted Power (dBm)	G _{T-Lc} (dB)	EIRP (dBm)	EIRP (mW)	Limit (W)
512	1850.2	29.86	-1.72	28.14	651.63	2
661	1880.0	29.47	-1.72	27.75	595.66	2
810	1909.8	29.14	-1.72	27.42	552.08	2

EDGE

Channel	Frequency (MHz)	Conducted Power (dBm)	G _{T-Lc} (dB)	EIRP (dBm)	EIRP (mW)	Limit (W)
512	1850.2	25.67	-1.72	23.95	248.31	2
661	1880.0	25.81	-1.72	24.09	256.45	2
810	1909.8	25.8	-1.72	24.08	255.86	2

WCDMA

Channel	Frequency (MHz)	Conducted Power (dBm)	G _{T-Lc} (dB)	EIRP (dBm)	EIRP (mW)	Limit (W)
9262	1852.4	24.07	-1.72	22.35	171.79	2
9400	1880	24.12	-1.72	22.4	173.78	2
9538	1907.6	24.14	-1.72	22.42	174.58	2



LTE BAND 2

CHANNEL BANDWIDTH: 1.4MHz QPSK

Channel	Frequency (MHz)	Conducted Power (dBm)	G _{T-Lc} (dB)	EIRP (dBm)	EIRP (mW)	Limit (W)
18607	1850.7	23.93	-1.72	22.21	166.34	2
18900	1880.0	23.93	-1.72	22.21	166.34	2
19193	1909.3	23.97	-1.72	22.25	167.88	2

CHANNEL BANDWIDTH: 1.4MHz 16QAM

Channel	Frequency (MHz)	Conducted Power (dBm)	G _{T-Lc} (dB)	EIRP (dBm)	EIRP (mW)	Limit (W)
18607	1850.7	23.04	-1.72	21.32	135.52	2
18900	1880.0	22.99	-1.72	21.27	133.97	2
19193	1909.3	23.07	-1.72	21.35	136.46	2

CHANNEL BANDWIDTH: 1.4MHz 64QAM

Channel	Frequency (MHz)	Conducted Power (dBm)	G _{T-Lc} (dB)	EIRP (dBm)	EIRP (mW)	Limit (W)
18607	1850.7	22.12	-1.72	20.4	109.65	2
18900	1880.0	22.21	-1.72	20.49	111.94	2
19193	1908.3	22.13	-1.72	20.41	109.9	2



CHANNEL BANDWIDTH: 3MHz QPSK

Channel	Frequency (MHz)	Conducted Power (dBm)	G _{T-Lc} (dB)	EIRP (dBm)	EIRP (mW)	Limit (W)
18615	1851.5	23.92	-1.72	22.2	165.96	2
18900	1880.0	23.84	-1.72	22.12	162.93	2
19185	1908.5	23.95	-1.72	22.23	167.11	2

CHANNEL BANDWIDTH: 3MHz 16QAM

Channel	Frequency (MHz)	Conducted Power (dBm)	G _{T-Lc} (dB)	EIRP (dBm)	EIRP (mW)	Limit (W)
18615	1851.5	22.96	-1.72	21.24	133.05	2
18900	1880.0	23.03	-1.72	21.31	135.21	2
19185	1908.5	23.02	-1.72	21.3	134.9	2

CHANNEL BANDWIDTH: 3MHz 64QAM

Channel	Frequency (MHz)	Conducted Power (dBm)	G _{T-Lc} (dB)	EIRP (dBm)	EIRP (mW)	Limit (W)
18615	1851.5	22.1	-1.72	20.38	109.14	2
18900	1880.0	22.19	-1.72	20.47	111.43	2
19185	1908.5	22.1	-1.72	20.38	109.14	2



**BUREAU
VERITAS**

Test Report No.: W7L-P23030003RF05

CHANNEL BANDWIDTH: 5MHz QPSK

Channel	Frequency (MHz)	Conducted Power (dBm)	G _{T-Lc} (dB)	EIRP (dBm)	EIRP (mW)	Limit (W)
18625	1852.5	23.86	-1.72	22.14	163.68	2
18900	1880.0	23.86	-1.72	22.14	163.68	2
19175	1907.5	23.94	-1.72	22.22	166.72	2

CHANNEL BANDWIDTH: 5MHz 16QAM

Channel	Frequency (MHz)	Conducted Power (dBm)	G _{T-Lc} (dB)	EIRP (dBm)	EIRP (mW)	Limit (W)
18625	1852.5	22.98	-1.72	21.26	133.66	2
18900	1880.0	22.99	-1.72	21.27	133.97	2
19175	1907.5	23.02	-1.72	21.3	134.9	2

CHANNEL BANDWIDTH: 5MHz 64QAM

Channel	Frequency (MHz)	Conducted Power (dBm)	G _{T-Lc} (dB)	EIRP (dBm)	EIRP (mW)	Limit (W)
18625	1852.5	22.12	-1.72	20.4	109.65	2
18900	1880.0	22.12	-1.72	20.4	109.65	2
19175	1907.5	22.09	-1.72	20.37	108.89	2



CHANNEL BANDWIDTH: 10MHz QPSK

Channel	Frequency (MHz)	Conducted Power (dBm)	G _{T-Lc} (dB)	EIRP (dBm)	EIRP (mW)	Limit (W)
18650	1855.0	23.93	-1.72	22.21	166.34	2
18900	1880.0	23.92	-1.72	22.2	165.96	2
19150	1905.0	23.94	-1.72	22.22	166.72	2

CHANNEL BANDWIDTH: 10MHz 16QAM

Channel	Frequency (MHz)	Conducted Power (dBm)	G _{T-Lc} (dB)	EIRP (dBm)	EIRP (mW)	Limit (W)
18650	1855.0	23.03	-1.72	21.31	135.21	2
18900	1880.0	23.03	-1.72	21.31	135.21	2
19150	1905.0	23.08	-1.72	21.36	136.77	2

CHANNEL BANDWIDTH: 10MHz 64QAM

Channel	Frequency (MHz)	Conducted Power (dBm)	G _{T-Lc} (dB)	EIRP (dBm)	EIRP (mW)	Limit (W)
18650	1855.0	22.19	-1.72	20.47	111.43	2
18900	1880.0	22.17	-1.72	20.45	110.92	2
19150	1905.0	22.14	-1.72	20.42	110.15	2



CHANNEL BANDWIDTH: 15MHz QPSK

Channel	Frequency (MHz)	Conducted Power (dBm)	G _{T-Lc} (dB)	EIRP (dBm)	EIRP (mW)	Limit (W)
18675	1857.5	23.9	-1.72	22.18	165.2	2
18900	1880.0	23.82	-1.72	22.1	162.18	2
19125	1902.5	23.94	-1.72	22.22	166.72	2

CHANNEL BANDWIDTH: 15MHz 16QAM

Channel	Frequency (MHz)	Conducted Power (dBm)	G _{T-Lc} (dB)	EIRP (dBm)	EIRP (mW)	Limit (W)
18675	1857.5	22.99	-1.72	21.27	133.97	2
18900	1880.0	22.97	-1.72	21.25	133.35	2
19125	1902.5	23.03	-1.72	21.31	135.21	2

CHANNEL BANDWIDTH: 15MHz 64QAM

Channel	Frequency (MHz)	Conducted Power (dBm)	G _{T-Lc} (dB)	EIRP (dBm)	EIRP (mW)	Limit (W)
18675	1857.5	22.15	-1.72	20.43	110.41	2
18900	1880.0	22.17	-1.72	20.45	110.92	2
19125	1902.5	22.09	-1.72	20.37	108.89	2



CHANNEL BANDWIDTH: 20MHz QPSK

Channel	Frequency (MHz)	Conducted Power (dBm)	G _{T-Lc} (dB)	EIRP (dBm)	EIRP (mW)	Limit (W)
18700	1860	23.99	-1.72	22.27	168.66	2
18900	1880	23.97	-1.72	22.25	167.88	2
19100	1900	24.02	-1.72	22.3	169.82	2

CHANNEL BANDWIDTH: 20MHz 16QAM

Channel	Frequency (MHz)	Conducted Power (dBm)	G _{T-Lc} (dB)	EIRP (dBm)	EIRP (mW)	Limit (W)
18700	1860	23.09	-1.72	21.37	137.09	2
18900	1880	23.1	-1.72	21.38	137.4	2
19100	1900	23.12	-1.72	21.4	138.04	2

CHANNEL BANDWIDTH: 20MHz 64QAM

Channel	Frequency (MHz)	Conducted Power (dBm)	G _{T-Lc} (dB)	EIRP (dBm)	EIRP (mW)	Limit (W)
18700	1860	22.23	-1.72	20.51	112.46	2
18900	1880	22.26	-1.72	20.54	113.24	2
19100	1900	22.21	-1.72	20.49	111.94	2



3.2 FREQUENCY STABILITY MEASUREMENT

3.2.1 LIMITS OF FREQUENCY STABILITY MEASUREMENT

The frequency stability shall be sufficient to ensure that the fundamental emission stays within the authorized frequency block.

3.2.2 TEST PROCEDURE

- a. Device is placed at the oven room. The oven room could control the temperatures and humidity. Power warm up is at least 15 min and power applied should perform before recording frequency error.
- b. EUT is connected the external power supply to control the DC input power. The test voltage range is from minimum to maximum working voltage. Each step shall be record the frequency error rate.
- c. The temperature range step is 10 degrees in this test items. All temperature levels shall be hold the $\pm 0.5^{\circ}\text{C}$ during the measurement testing. The each temperature step shall be at least 0.5 hours, consider the EUT could be test under the stability condition.

NOTE: The frequency error was recorded frequency error from the communication simulator.

3.2.3 TEST SETUP

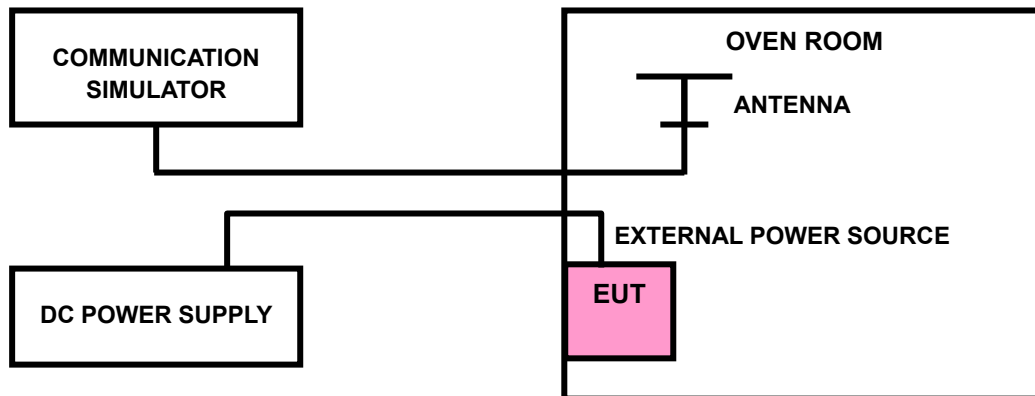



Test Report No.: W7L-P23030003RF05

3.2.4 TEST RESULTS

Please Refer to Appendix Of this test report.



3.3 OCCUPIED BANDWIDTH MEASUREMENT

3.3.1 LIMITS OF OCCUPIED BANDWIDTH MEASUREMENT

The width of a frequency band such that, below the lower and above the upper frequency limits, the mean powers emitted are each equal to a specified percentage 0.5 % of the total mean power of a given emission.

3.3.2 TEST SETUP

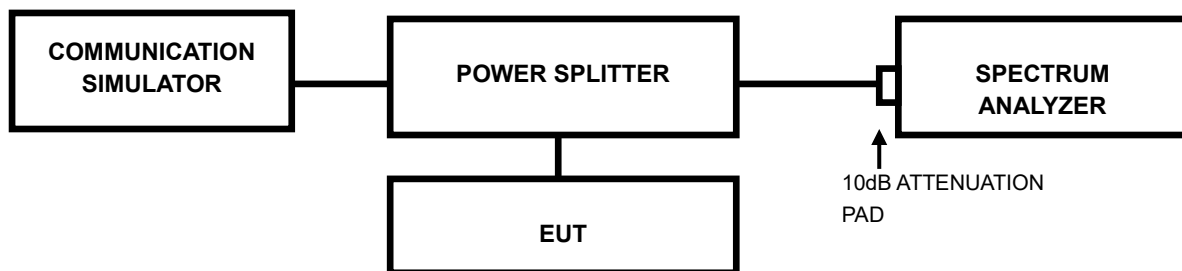

3.3.3 TEST PROCEDURES

- The conducted occupied bandwidth used the power splitter via EUT RF power connector between simulation base station and spectrum analyzer.
- Use OBW measurement function of Spectrum analyzer to measure 99 % occupied bandwidth.



Test Report No.: W7L-P23030003RF05

3.3.4 TEST RESULTS

Please Refer to Appendix Of this test report.