

FCC TEST REPORT (PART 24)



Applicant:	Xiaomi Communications Co., Ltd.
Address:	#019, 9th Floor, Building 6, 33 Xi'erqi Middle Road, Haidian District, Beijing, China, 100085

Manufacturer or Supplier:	Xiaomi Communications Co., Ltd.
Address:	#019, 9th Floor, Building 6, 33 Xi'erqi Middle Road, Haidian District, Beijing, China, 100085
Product:	Mobile Phone
Brand Name:	Redmi
Model Name:	23053RN02A
FCC ID:	2AFZZRN02A
Date of tests:	Mar. 06, 2023 ~ Mar. 29, 2023

The tests have been carried out according to the requirements of the following standard:

- FCC PART 24, Subpart E**
 FCC PART 2
 ANSI/TIA/EIA-603-D
 ANSI/TIA/EIA-603-E
 ANSI C63.26-2015

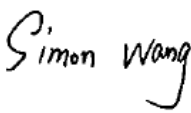
CONCLUSION: The submitted sample was found to COMPLY with the test requirement

Prepared by Simon Wang Engineer / Mobile Department	Approved by Luke Lu Manager / Mobile Department
	
Date: Mar. 29, 2023	Date: Mar. 29, 2023

This report is governed by, and incorporates by reference, the Conditions of Testing as posted at the date of issuance of this report at <http://www.bureauveritas.com/home/about-us/our-business/cps/about-us/terms-conditions/> and is intended for your exclusive use. Any copying or replication of this report to or for any other person or entity, or use of our name or trademark, is permitted only with our prior written permission. This report sets forth our findings solely with respect to the test samples identified herein. The results set forth in this report are not indicative or representative of the quality or characteristics of the lot from which a test sample was taken or any similar or identical product unless specifically and expressly noted. Our report includes all of the tests requested by you and the results thereof based upon the information that you provided to us. Measurement uncertainty is only provided upon request for accredited tests. Statements of conformity are based on simple acceptance criteria without taking measurement uncertainty into account, unless otherwise requested in writing. You have 60 days from date of issuance of this report to notify us of any material error or omission caused by our negligence or if you require measurement uncertainty; provided, however, that such notice shall be in writing and shall specifically address the issue you wish to raise. A failure to raise such issue within the prescribed time shall constitute your unqualified acceptance of the completeness of this report, the tests conducted and the correctness of the report contents.



TABLE OF CONTENTS

RELEASE CONTROL RECORD	4
1 SUMMARY OF TEST RESULTS	5
1.1 MEASUREMENT UNCERTAINTY	6
1.2 TEST SITE AND INSTRUMENTS	7
2 GENERAL INFORMATION	9
2.1 GENERAL DESCRIPTION OF EUT	9
2.2 CONFIGURATION OF SYSTEM UNDER TEST	11
2.3 DESCRIPTION OF SUPPORT UNITS	12
2.4 TEST ITEM AND TEST CONFIGURATION.....	12
2.5 EUT OPERATING CONDITIONS	13
2.6 GENERAL DESCRIPTION OF APPLIED STANDARDS	13
3 TEST TYPES AND RESULTS	14
3.1 OUTPUT POWER MEASUREMENT	14
3.1.1 LIMITS OF OUTPUT POWER MEASUREMENT	14
3.1.2 TEST PROCEDURES	14
3.1.3 TEST SETUP	15
3.1.4 TEST RESULTS	15
3.2 FREQUENCY STABILITY MEASUREMENT	19
3.2.1 LIMITS OF FREQUENCY STABILITY MEASUREMENT	19
3.2.2 TEST PROCEDURE	19
3.2.3 TEST SETUP	19
3.2.4 TEST RESULTS	20
3.3 OCCUPIED BANDWIDTH MEASUREMENT	21
3.3.1 LIMITS OF OCCUPIED BANDWIDTH MEASUREMENT	21
3.3.2 TEST SETUP	21
3.3.3 TEST PROCEDURES	21
3.3.4 TEST RESULTS	22
3.4 BAND EDGE MEASUREMENTC	23
3.4.1 LIMITS OF BAND EDGE MEASUREMENT	23
3.4.2 TEST SETUP	23
3.4.3 TEST PROCEDURES	24
3.4.4. TEST RESULTS	25
3.5 CONDUCTED SPURIOUS EMISSIONS.....	26
3.5.1 LIMITS OF CONDUCTED SPURIOUS EMISSIONS MEASUREMENT	26
3.5.2 TEST PROCEDURE	26
3.5.3 TEST SETUP	26
3.5.4 TEST RESULTS	27
3.6 RADIATED EMISSION MEASUREMENT	28
3.6.1 LIMITS OF RADIATED EMISSION MEASUREMENT	28
3.6.2 TEST PROCEDURES	28



**BUREAU
VERITAS**

Test Report No.: W7L-P23030005RF05

3.6.3 DEVIATION FROM TEST STANDARD	28
3.6.4 TEST SETUP	29
3.6.5 TEST RESULTS	31
3.7 PEAK TO AVERAGE RATIO	45
3.7.1 LIMITS OF PEAK TO AVERAGE RATIO MEASUREMENT	45
3.7.2 TEST SETUP	45
3.7.3 TEST PROCEDURES	45
3.7.4 TEST RESULTS	46
4 INFORMATION ON THE TESTING LABORATORIES	47
5 MODIFICATIONS RECORDERS FOR ENGINEERING CHANGES TO THE EUT BY THE LAB.....	48
6 APPENDIX	49
GSM1900	49



BUREAU
VERITAS

Test Report No.: W7L-P23030005RF05

RELEASE CONTROL RECORD

ISSUE NO.	REASON FOR CHANGE	DATE ISSUED
W7L-P23030005RF05	Original release	Mar. 29, 2023



1 SUMMARY OF TEST RESULTS

The EUT has been tested according to the following specifications:

APPLIED STANDARD: FCC Part 24 & Part 2			
STANDARD SECTION	TEST TYPE	RESULT	TEST LAB*
§2.1046	Coducted Output Power	Compliance	A
§24.232(c)	Equivalent Isotropic Radiated Power	Compliance	A
§2.1055 §24.235	Frequency Stability	Compliance	A
§2.1049	Occupied Bandwidth	Compliance	A
§24.232(d)	Peak to average ratio	Compliance	A
§24.238(a)(b)	Band Edge Measurements	Compliance	A
§2.1051 §24.238(a)(b)	Conducted Spurious Emissions	Compliance	A
§2.1053 §24.238(a)(b)	Radiated Spurious Emissions	Compliance	B

NOTE: This report refers to the data of W7L-P23030003RF05 (FCC ID: 2AFZZRN02L, model: 23053RN02L), the difference between 23053RN02L and 23053RN02A is model, FCC ID and supporting bands. 23053RN02A remove WCDMA B2<E B2& LTE B2& LTE B4& LTE B12& LTE B13& LTE B17& LTE B26& LTE B66, The new Sample only verify RSE worst case and conducted power, So this report only replaces conducted Power and the low frequency data and the high frequency data (GSM 1900 CH661) of RSE.

***Test Lab Information Reference**

Lab A:

BV 7Layers Communications Technology (Shenzhen) Co., Ltd

Lab Address:

No.B102, Dazu Chuangxin Mansion, North of Beihuan Avenue, North Area, Hi-Tech Industrial Park, Nanshan District, Shenzhen, Guangdong, China

Accredited Test Lab Cert 3939.01

The FCC Site Registration No. : 525120; Designation No. : CN1171;

Lab B:

Huarui 7Layers High Technology (Suzhou) Co., Ltd.

Lab Address:

Tower N, Innovation Center, 88 Zhuyi Road, High-tech District, Suzhou City, Anhui Province

Accredited Test Lab Cert 6613.01



**BUREAU
VERITAS**

Test Report No.: W7L-P23030005RF05

The FCC Site Registration No. is 434559; The Designation No. is CN1325.

1.1 MEASUREMENT UNCERTAINTY

Where relevant, the following measurement uncertainty levels have been estimated for tests performed on the EUT as specified in CISPR 16-4-2:

MEASUREMENT	UNCERTAINTY
Frequency Stability	$\pm 76.97\text{Hz}$
Radiated emissions (9KHz~30MHz)	$\pm 2.68\text{dB}$
Radiated emissions & Radiated Power (30MHz~1GHz)	$\pm 4.98\text{dB}$
Radiated emissions & Radiated Power (1GHz ~6GHz)	$\pm 4.70\text{dB}$
Radiated emissions (6GHz ~18GHz)	$\pm 4.60\text{dB}$
Radiated emissions (18GHz ~40GHz)	$\pm 4.12\text{dB}$
Conducted emissions	$\pm 4.01\text{dB}$
Occupied Channel Bandwidth	$\pm 43.58\text{KHz}$
Conducted Output power	$\pm 2.06\text{dB}$
Band Edge Measurements	$\pm 4.70\text{dB}$
Peak to average ratio	$\pm 0.76\text{dB}$

This uncertainty represents an expanded uncertainty expressed at approximately the 95% confidence level using a coverage factor of $k=2$.



1.2 TEST SITE AND INSTRUMENTS

Equipment	Manufacturer	Model No.	Serial No.	Last Cal.	Next Cal.
MXE EMI Receiver	KEYSIGHT	N9038A-544	MY54450026	Feb. 17,23	Feb. 16,24
EXA Signal Analyzer	KEYSIGHT	N9010A-544	MY54510355	May.14,22	May.13,23
Loop Antenna	Schwarzbeck	FMZB 1519B	00173	Sep.03,22	Sep.02,23
Bilog Antenna	ETS-LINDGREN	3143B	00161965	Mar. 05,23	Mar. 04,24
Horn Antenna	ETS-LINDGREN	3117	00168692	Mar. 05,23	Mar. 04,24
Horn Antenna (18GHz-40GHz)	N/A	QWH-SL-18-40- K-SG/QMS-003 61	15433	Sep.04, 22	Sep.03, 23
Radio Communication Analyzer	ANRITSU	MT8820C	6201465426	Feb. 14,23	Feb. 13,24
Signal Pre-Amplifier	EMSI	EMC 9135	980249	May.12,22	May.11,23
Signal Pre-Amplifier	EMSI	EMC 012645B	980257	May.12,22	May.11,23
Signal Pre-Amplifier	EMSI	EMC 184045B	980259	Feb. 17,23	Feb.16,24
3m Semi-anechoic Chamber	ETS-LINDGREN	9m*6m*6m	Euroshieldpn- CT0001143-121 6	May. 19,20	May. 18,23
Test Software	E3	V 9.160323	N/A	N/A	N/A
Test Software	JS1120	3.1.36	N/A	N/A	N/A
10dB Attenuator	JFW/USA	50HF-010-SMA	N/A	May. 12,22	May. 11,23
Power Meter	Anritsu	ML2495A	1506002	Feb. 14,23	Feb. 13,24
Power Sensor	Anritsu	MA2411B	1339352	Feb. 14,23	Feb. 13,24
Temperature Chamber	ESPEC	SH-242	93000855	May. 12,22	May. 11,23
MXG Analog Microwave Signal Generator	KEYSIGHT	N5183A	MY50143024	Feb. 14,23	Feb. 13,24
Base station R&S CMW500	Rohde&Schwarz	CMW500	153085	May.12,22	May.11,23
DC Source	Kikusui/JP	PMX18-5A	N/A	Aug. 12,22	Aug. 11,23

- NOTE:** 1. The calibration interval of the above test instruments is 12 months or 36 months and the calibrations are traceable to CEPREI/CHINA, GRGT/CHINA and NIM/CHINA.
2. The test was performed in 3m Semi-anechoic Chamber and RF Oven Room.
3. The horn antenna is used only for the measurement of emission frequency above 1GHz if tested.
4. The FCC Site Registration No. is 525120; The Designation No. is CN1171.

Equipment	Manufacturer	Model No.	Serial No.	Last Cal.	Next Cal.
Pre-Amplifier	R&S	SCU18F1	100815	Aug.30,22	Aug.29,24
Pre-Amplifier	R&S	SCU08F1	101028	Sep.16,22	Sep.15,24
Vector Signal Generator	R&S	SMBV100B	102176	Feb.16,22	Feb.15,24
Signal Generator	R&S	SMB100A	182185	Feb.16,22	Feb.15,24
3m Fully-anechoic Chamber	TDK	9m*6m*6m	HRSW-SZ- EMC-01Ch amber	Nov.25,22	Nov.24,25



3m Semi-anechoic Chamber	TDK	9m*6m*6m	HRSW-SZ-EMC-02Chamber	Nov.25,22	Nov.24,25
EMI TEST Receiver	R&S	ESR26	101734	Feb.25,22	Feb.24,24
EMI TEST Receiver	R&S	ESW44	101973	Feb.25,22	Feb.24,24
Bilog Antenna	SCHWARZBECK	VULB 9163	1264	Feb.28,22	Feb.27,24
Horn Antenna	ETS-LINDGREN	3117	227836	Aug.22,22	Aug.21,24
Horn Antenna (18GHz-40GHz)	Steatite Q-par Antennas	QMS 00880	23486	Feb.23,22	Feb.22,24
Horn Antenna	Steatite Q-par Antennas	QMS 00208	23485	Aug.22,22	Aug.21,24
Loop Antenna	SCHWARZ	HFH2-Z2/Z2E	100976	Feb.23,22	Feb.22,24
WIDEBANDRADIO COMMUNICATION TESTER	R&S	CMW500	169399	Jun.27,22	Jun.26,24
Test Software	EMC32	EMC32	N/A	N/A	N/A
Test Software	ELEKTRA	ELEKTRA4.32	N/A	N/A	N/A
Open Switch and Control Unit	R&S	OSP220	101964	Oct.01,22	Sep.30,24
DC Source	HYELEC	HY3010B	551016	Aug.31,22	Aug.30,24
Hygrothermograph	DELI	20210528	SZ014	Sep.06,22	Sep.05,24
PC	LENOVO	E14	HRSW0024	N/A	N/A
TMC-AMI18843A(CABLE)	R&S	HF290-NMNM-7.00M	N/A	N/A	N/A
TMC-AMI18843A(CABLE)	R&S	HF290-NMNM-4.00M	N/A	N/A	N/A
CABLE	R&S	W13.02	N/A	Oct.31,22	Apr.29,23
CABLE	R&S	W12.14	N/A	Oct.31,22	Apr.29,23
CABLE	R&S	J12J103539-00-1	SEP-03-20-069	Oct.31,22	Apr.29,23
CABLE	R&S	J12J103539-00-1	SEP-03-20-070	Oct.31,22	Apr.29,23
Temperature Chamber	votsch	VT4002	58566078100050	May.31,22	May.30,24

- NOTE:**
1. The calibration interval of the above test instruments is 12 months or 36 months and the calibrations are traceable to CEPREI/CHINA, GRGT/CHINA and NIM/CHINA.
 2. The test was performed in 3m Semi-anechoic Chamber and RF Oven Room.
 3. The horn antenna is used only for the measurement of emission frequency above 1GHz if tested.
 4. The FCC Site Registration No. is 434559; The Designation No. is CN1325.



2 GENERAL INFORMATION

2.1 GENERAL DESCRIPTION OF EUT

PRODUCT	Mobile Phone	
BRAND NAME	Redmi	
MODEL NAME	23053RN02A	
NOMINAL VOLTAGE	5V/9V/10V/12Vdc(adapter or host equipment) 3.8Vdc (Li-ion, battery)	
MODULATION TYPE	GSM: GMSK EDGE: 8PSK	
FREQUENCY RANGE	GSM, EDGE	1850.2MHz ~ 1909.8MHz
MAX. EIRP POWER	GSM	628.06mW
	EDGE	254.1mW
EMISSION DESIGNATOR	GSM	247KGXW
	EDGE	251KG7W
ANTENNA TYPE	ANT 0: IFA Antenna with -1.88dBi gain for GSM1900 ANT 4: IFA Antenna with -1.72dBi gain for GSM1900	
HW VERSION	P1.1	
SW VERSION	MIUI14	
IMEI	861065060020543 861065060023927 861065060023935	
I/O PORTS	Refer to user's manual	
CABLE SUPPLIED	USB cable1: non-shielded cable, with w/o ferrite core, 1.0 meter USB cable2: non-shielded cable, with w/o ferrite core, 1.0 meter	
EXTREME TEMPERATURE	0-40 °C	
EXTREME VOLTAGE	3.5V - 4.2V	

NOTE:

1. For a more detailed features description, please refer to the manufacturer's specifications or the user's manual.



**BUREAU
VERITAS**

Test Report No.: W7L-P23030005RF05

2. The EUT incorporates a SISO function. Physically, the EUT provides two completed transmitter and one receiver.

MODULATION MODE	TX FUNCTION
GSM/GPRS/EDGE	2TX/2RX

3. For the test results, the EUT had been tested with all conditions. But only the worst case was shown in test report.



2.2 CONFIGURATION OF SYSTEM UNDER TEST

FOR RADIATION EMISSION TEST

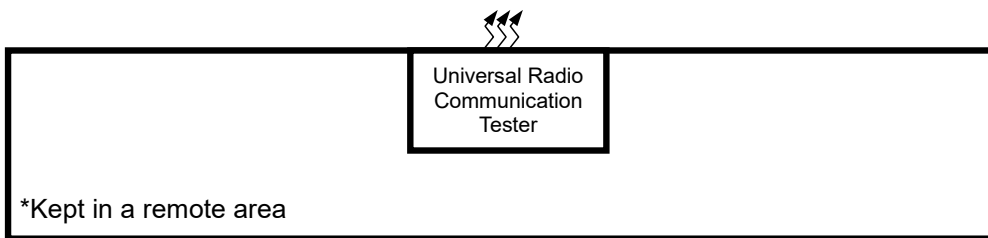
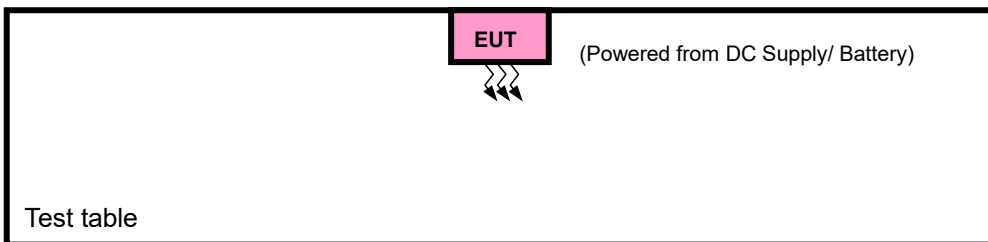
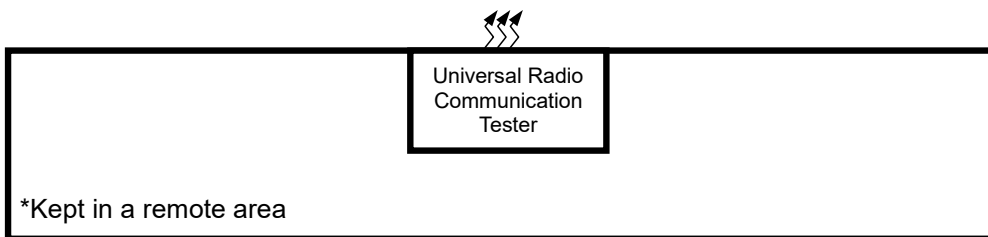
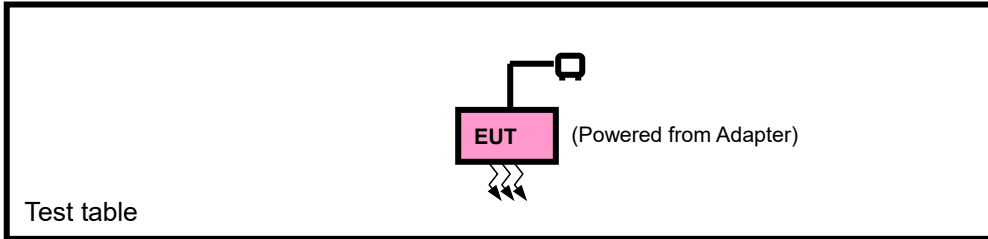



2.3 DESCRIPTION OF SUPPORT UNITS

The EUT has been tested as an independent unit together with other necessary accessories or support units. The following support units or accessories were used to form a representative test configuration during the tests.

NO.	PRODUCT	BRAND	MODEL NO.	SERIAL NO.	FCC ID
1	DC source	Kikusui/JP	PMX18-5A	0000001	N/A

NO.	SIGNAL CABLE DESCRIPTION OF THE ABOVE SUPPORT UNITS
1	DC Line: Unshielded, Detachable 1.0m

2.4 TEST ITEM AND TEST CONFIGURATION

Pre-Scan has been conducted to determine the worst-case mode from all possible combinations between available modulations, data rates, XYZ axis and antenna ports. The worst case in EIRP and radiated emission was found when positioned on X-plane for GSM/EDGE. Following channel(s) was (were) selected for the final test as listed below:

EUT CONFIGURE MODE	DESCRIPTION
A	EUT + Adapter with GSM or WCDMA or LTE link
B	EUT + DC source with GSM or WCDMA or LTE link

GSM MODE

EUT CONFIGURE MODE	TEST ITEM	AVAILABLE CHANNEL	TESTED CHANNEL	MODE
A	EIRP	512 to 810	512, 661, 810	GSM,EDGE
B	FREQUENCY STABILITY	512 to 810	512, 661, 810	GSM,EDGE
A	OCCUPIED BANDWIDTH	512 to 810	512, 661, 810	GSM,EDGE
A	PEAK TO AVERAGE RATIO	512 to 810	512, 661, 810	GSM,EDGE
A	BAND EDGE	512 to 810	512, 810	GSM,EDGE
A	CONDCUDED EMISSION	512 to 810	512, 661, 810	GSM,EDGE
A	RADIATED EMISSION	512 to 810	512, 661, 810	GSM,EDGE



TEST CONDITION:

TEST ITEM	ENVIRONMENTAL CONDITIONS	INPUT POWER	TESTED BY
EIRP	25deg. C, 57%RH	DC 5V/9V/10V/12V By Adapter	Jace Hu
FREQUENCY STABILITY	23deg. C, 61%RH	DC 3.5/3.8/4.2 By DC Source	James Fu
OCCUPIED BANDWIDTH	23deg. C, 61%RH	DC 5V/9V/10V/12V By Adapter	James Fu
PEAK TO AVERAGE RATIO	23deg. C, 61%RH	DC 5V/9V/10V/12V By Adapter	James Fu
BAND EDGE	23deg. C, 61%RH	DC 5V/9V/10V/12V By Adapter	James Fu
CONDCUDED EMISSION	23deg. C, 61%RH	DC 5V/9V/10V/12V By Adapter	James Fu
RADIATED EMISSION	23deg. C, 70%RH	DC 5V/9V/10V/12V By Adapter	Jace Hu

2.5 EUT OPERATING CONDITIONS

The EUT makes a call to the communication simulator. The communication simulator station system controlled a EUT to export maximum output power under transmission mode and specific channel frequency

2.6 GENERAL DESCRIPTION OF APPLIED STANDARDS

The EUT is a RF product. According to the specifications of the manufacturer, it must comply with the requirements of the following standards:

FCC 47 CFR Part 2

FCC 47 CFR Part 24

KDB 971168 D01 Power Meas License Digital Systems v03r01

ANSI/TIA/EIA-603-D

ANSI/TIA/EIA-603-E

ANSI C63.26-2015

NOTE: All test items have been performed and recorded as per the above standards.



3 TEST TYPES AND RESULTS

3.1 OUTPUT POWER MEASUREMENT

3.1.1 LIMITS OF OUTPUT POWER MEASUREMENT

Mobile and portable stations are limited to 2 watts EIRP.

3.1.2 TEST PROCEDURES

EIRP MEASUREMENT:

Per KDB 971168 D01 Power Meas License Digital Systems v03r01 or subclause 5.2.5.5 of ANSI C63.26-2015, the relevant equation for determining the ERP or EIRP from the conducted RF output power measured using the guidance provided above is:

$$\text{ERP or EIRP} = P_{\text{Meas}} + G_{\text{T}} - L_{\text{C}}$$

Where:

ERP or EIRP = effective radiated power or equivalent isotropically radiated power, respectively

(expressed in the same units as P_{Meas} , typically dBW or dBm);

P_{Meas} = measured transmitter output power or PSD, in dBm or dBW;

G_{T} = gain of the transmitting antenna, in dBd (ERP) or dBi (EIRP);

L_{C} = signal attenuation in the connecting cable between the transmitter and antenna, in dB.

CONDUCTED POWER MEASUREMENT:

The EUT was set up for the maximum power with WCDMA link data modulation and link up with simulator. Set the EUT to transmit under low, middle and high channel and record the power level shown on simulator.



3.1.3 TEST SETUP

EIRP / ERP Measurement:

CONDUCTED POWER MEASUREMENT:

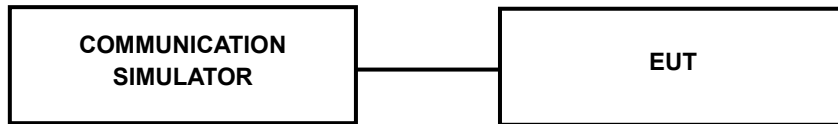

3.1.4 TEST RESULTS

CONDUCTED OUTPUT POWER (dBm)

Ant 0

Band	GSM1900		
Channel	512	661	810
Frequency	1850.2	1880	1909.8
GSM	29.32	29.51	29.16
GPRS (GMSK, 1Tx-slot)	29.30	29.50	29.14
GPRS (GMSK, 2Tx-slot)	28.55	28.76	28.45
GPRS (GMSK, 3Tx-slot)	26.67	26.97	26.66
GPRS (GMSK, 4Tx-slot)	25.66	25.95	25.68
EDGE (8PSK, 1Tx-slot)	25.74	25.61	25.81
EDGE (8PSK, 2Tx-slot)	24.64	24.52	24.73
EDGE (8PSK, 3Tx-slot)	22.68	22.41	22.65
EDGE (8PSK, 4Tx-slot)	21.34	21.33	21.41



BUREAU
VERITAS

Test Report No.: W7L-P23030005RF05

Ant 4

Band	GSM1900		
Channel	512	661	810
Frequency	1850.2	1880	1909.8
GSM	29.70	29.66	29.25
GPRS (GMSK, 1Tx-slot)	29.68	29.65	29.23
GPRS (GMSK, 2Tx-slot)	28.93	28.95	28.54
GPRS (GMSK, 3Tx-slot)	27.06	27.21	26.79
GPRS (GMSK, 4Tx-slot)	26.09	26.19	25.81
EDGE (8PSK, 1Tx-slot)	25.65	25.68	25.77
EDGE (8PSK, 2Tx-slot)	24.45	24.69	24.71
EDGE (8PSK, 3Tx-slot)	22.36	22.56	22.77
EDGE (8PSK, 4Tx-slot)	21.24	21.33	21.56



BUREAU
VERITAS

Test Report No.: W7L-P23030005RF05

EIRP POWER (dBm)

Ant 0

GSM

Channel	Frequency (MHz)	Conducted Power (dBm)	G _T -L _C (dB)	EIRP (dBm)	EIRP (mW)	Limit (W)
512	1850.2	29.32	-1.88	27.44	554.63	2
661	1880.0	29.51	-1.88	27.63	579.43	2
810	1909.8	29.16	-1.88	27.28	534.56	2

EDGE

Channel	Frequency (MHz)	Conducted Power (dBm)	G _T -L _C (dB)	EIRP (dBm)	EIRP (mW)	Limit (W)
512	1850.2	25.74	-1.88	23.86	243.22	2
661	1880.0	25.61	-1.88	23.73	236.05	2
810	1909.8	25.81	-1.88	23.93	247.17	2



**BUREAU
VERITAS**

Test Report No.: W7L-P23030005RF05

Ant 4

GSM

Channel	Frequency (MHz)	Conducted Power (dBm)	G _{T-Lc} (dB)	EIRP (dBm)	EIRP (mW)	Limit (W)
512	1850.2	29.7	-1.72	27.98	628.06	2
661	1880.0	29.66	-1.72	27.94	622.3	2
810	1909.8	29.25	-1.72	27.53	566.24	2

EDGE

Channel	Frequency (MHz)	Conducted Power (dBm)	G _{T-Lc} (dB)	EIRP (dBm)	EIRP (mW)	Limit (W)
512	1850.2	25.65	-1.72	23.93	247.17	2
661	1880.0	25.68	-1.72	23.96	248.89	2
810	1909.8	25.77	-1.72	24.05	254.1	2



3.2 FREQUENCY STABILITY MEASUREMENT

3.2.1 LIMITS OF FREQUENCY STABILITY MEASUREMENT

The frequency stability shall be sufficient to ensure that the fundamental emission stays within the authorized frequency block.

3.2.2 TEST PROCEDURE

- a. Device is placed at the oven room. The oven room could control the temperatures and humidity. Power warm up is at least 15 min and power applied should perform before recording frequency error.
- b. EUT is connected the external power supply to control the DC input power. The test voltage range is from minimum to maximum working voltage. Each step shall be record the frequency error rate.
- c. The temperature range step is 10 degrees in this test items. All temperature levels shall be hold the $\pm 0.5^{\circ}\text{C}$ during the measurement testing. The each temperature step shall be at least 0.5 hours, consider the EUT could be test under the stability condition.

NOTE: The frequency error was recorded frequency error from the communication simulator.

3.2.3 TEST SETUP

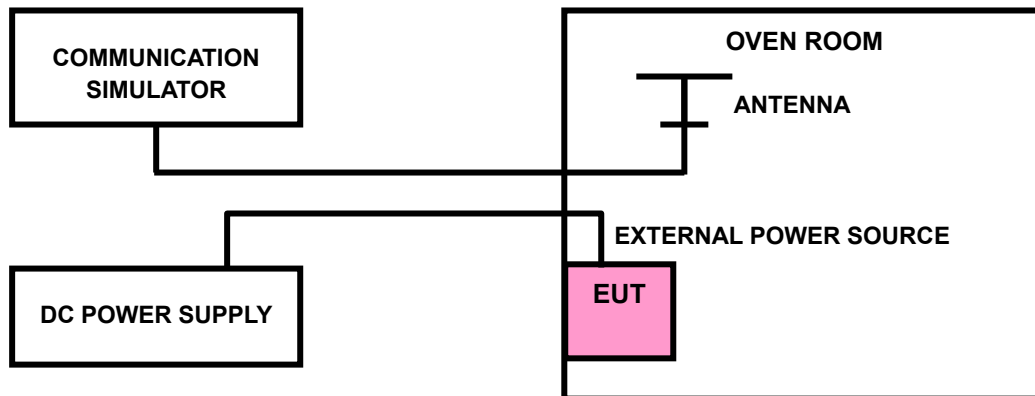



**BUREAU
VERITAS**

Test Report No.: W7L-P23030005RF05

3.2.4 TEST RESULTS

Please Refer to Appendix Of this test report.



3.3 OCCUPIED BANDWIDTH MEASUREMENT

3.3.1 LIMITS OF OCCUPIED BANDWIDTH MEASUREMENT

The width of a frequency band such that, below the lower and above the upper frequency limits, the mean powers emitted are each equal to a specified percentage 0.5 % of the total mean power of a given emission.

3.3.2 TEST SETUP

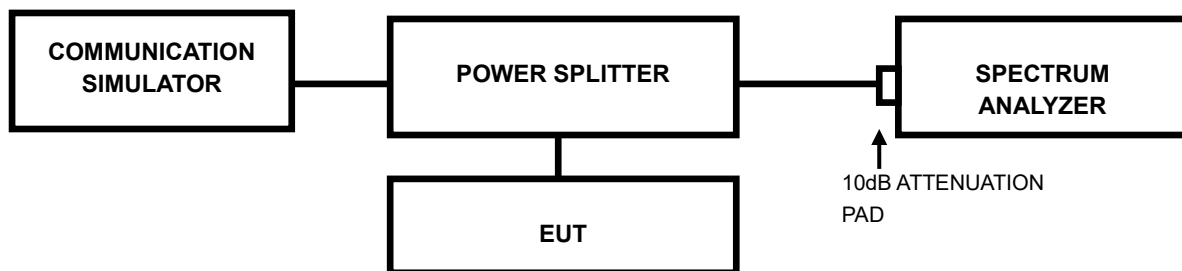

3.3.3 TEST PROCEDURES

- The conducted occupied bandwidth used the power splitter via EUT RF power connector between simulation base station and spectrum analyzer.
- Use OBW measurement function of Spectrum analyzer to measure 99 % occupied bandwidth.



Test Report No.: W7L-P23030005RF05

3.3.4 TEST RESULTS

Please Refer to Appendix Of this test report.



3.4 BAND EDGE MEASUREMENTC

3.4.1 LIMITS OF BAND EDGE MEASUREMENT

Power of any emission outside of the authorized operating frequency ranges must be attenuated below the transmitting power (P) by a factor of at least $43 + 10 \log(P)$ dB. In the 1 MHz bands immediately outside and adjacent to the frequency block a resolution bandwidth of at least one percent of the emission bandwidth of the fundamental emission of the transmitter may be employed.

3.4.2 TEST SETUP

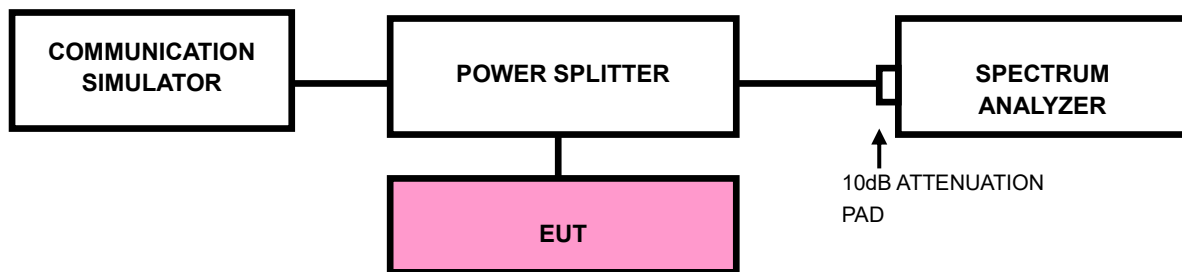



3.4.3 TEST PROCEDURES

- a) All measurements were done at low and high operational frequency range
- b) Connect the transmitter to the spectrum analyzer via coaxial cable while ensuring proper impedance matching.
- c) Tune the analyzer to the nominal center frequency of the emission bandwidth (EBW)
- d) .Set the resolution bandwidth (RBW) $\geq 1\%$ EBW in the 1MHz band immediately outside and adjacent to the band edge.
- e) Beyond the 1MHz band from the band edge, RBW=1MHz was used.
- f) Set the video bandwidth (VBW) to $\geq 3 \times$ RBW.
- g) Select the average power (RMS) display detector.
- h) Set the number of measurement points to ≥ 1001 .
- i) Use auto-coupled sweep time.
- j) Perform the measurement over an interval of time when the transmission is continuous and at its maximum power level.
- k) The RF fundamental frequency should be excluded against the limit line in the operating frequency band and use RBW is 10KHz or 100KHz.
- l) Record the max trace plot into the test report.



Test Report No.: W7L-P23030005RF05

3.4.4. TEST RESULTS

Please Refer to Appendix Of this test report.



3.5 CONDUCTED SPURIOUS EMISSIONS

3.5.1 LIMITS OF CONDUCTED SPURIOUS EMISSIONS MEASUREMENT

The power of any emission outside of the authorized operating frequency ranges must be attenuated below the transmitting power (P) by a factor of at least $43 + 10 \log(P)$ dB. The emission limit equal to -13dBm .

3.5.2 TEST PROCEDURE

- The EUT makes a phone call to the communication simulator. All measurements were done at low, middle and high operational frequency range.
- Measuring frequency range is from 30MHz up to a frequency including its 10th harmonic. 10dB attenuation pad is connected with spectrum. RBW=1MHz and VBW=3MHz is used for conducted emission measurement.

3.5.3 TEST SETUP

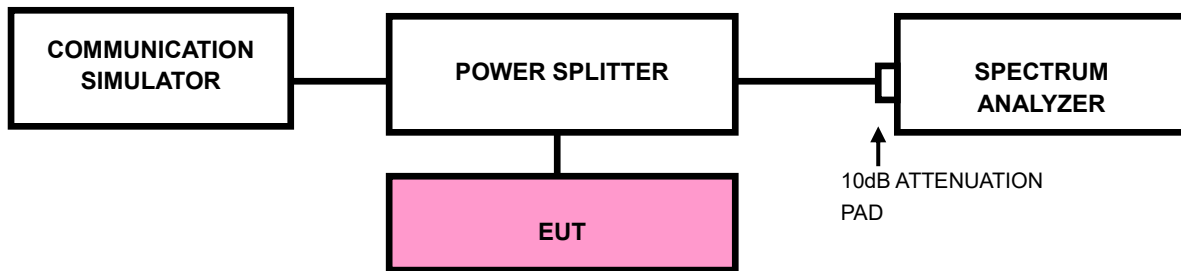



**BUREAU
VERITAS**

Test Report No.: W7L-P23030005RF05

3.5.4 TEST RESULTS

NOTE : The 9K~30MHz amplitude of spurious emissions attenuated more than 20 dB below the permissible value is not required in the report.

Please Refer to Appendix Of this test report.



3.6 RADIATED EMISSION MEASUREMENT

3.6.1 LIMITS OF RADIATED EMISSION MEASUREMENT

The power of any emission outside of the authorized operating frequency ranges must be attenuated below the transmitting power (P) by a factor of at least $43 + 10 \log(P)$ dB. The emission limit equal to -13dBm .

3.6.2 TEST PROCEDURES

- a. Substitution method is used for E.I.R.P measurement. In the semi-anechoic chamber, EUT placed on the 0.8m height of Turn Table, rotated the table around 360 degrees to search the maximum radiation power and receiver antenna shall be rotated vertical and horizontal polarization and moved height from 1m to 4m to find the maximum polar radiated power. The “Read Value” is the spectrum reading the maximum power value.
- b. The substitution horn antenna is substituted for EUT at the same position and signals generator export the CW signal to the substitution antenna via a TX cable. Rotated the Turn Table and moved receiving antenna to find the maximum radiation power. Adjust output power level of S.G to get a Value of spectrum reading equal to “Read Value “ of step a. Record the power level of S.G
- c. $\text{EIRP} = \text{Output power level of S.G} - \text{TX cable loss} + \text{Antenna gain of substitution horn}$.

NOTE: The resolution bandwidth and video bandwidth of test receiver/spectrum analyzer is 1MHz/3MHz.

3.6.3 DEVIATION FROM TEST STANDARD

No deviation



3.6.4 TEST SETUP

< Frequency Range below 30MHz >

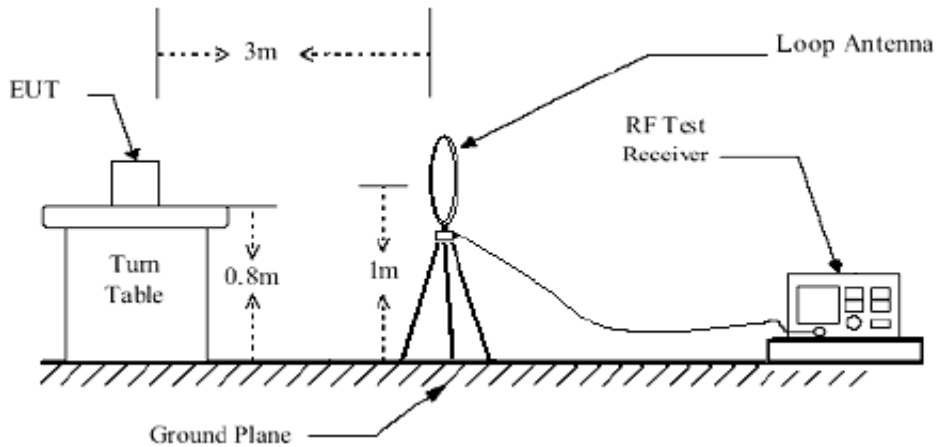

< Frequency Range 30MHz~1GHz >

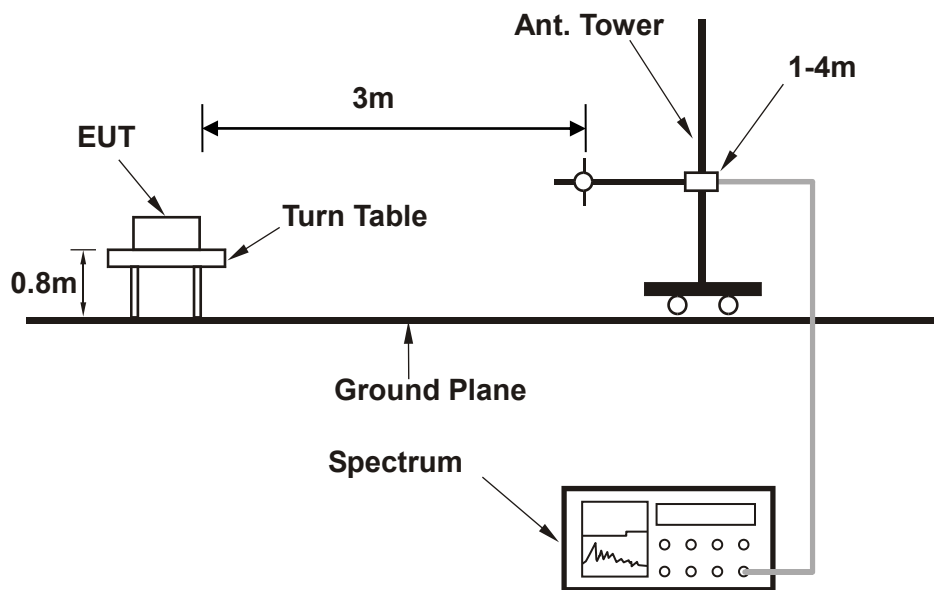



<Frequency Range above 1GHz>

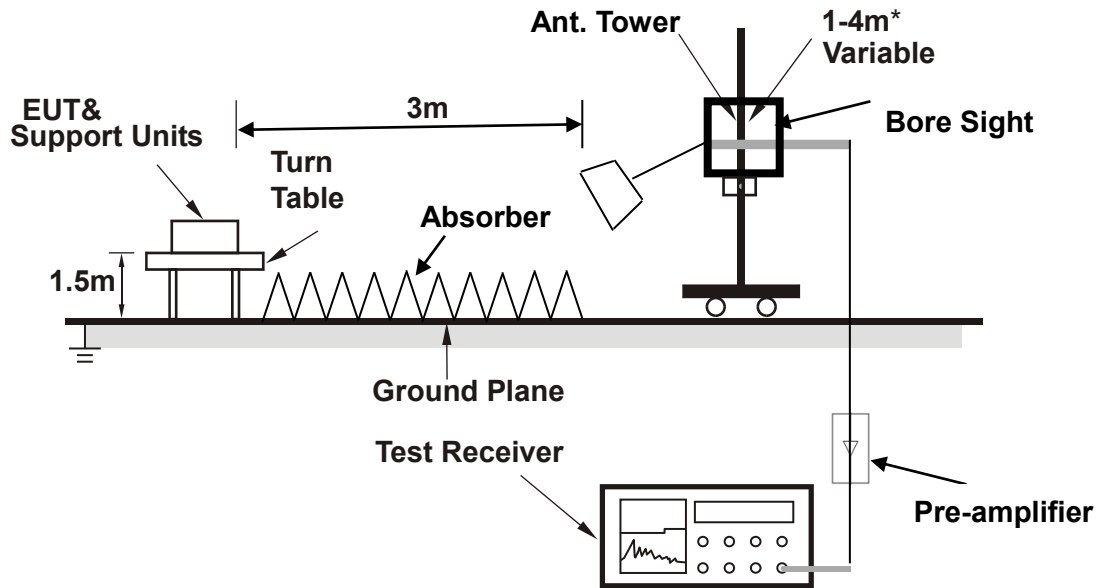

Note: Above 1G is a directional antenna

Depends on the EUT height and the antenna 3dB beamwidth both, refer to section 7.3 of CISPR 16-2-3.

For the actual test configuration, please refer to the attached file (Test Setup Photo).



3.6.5 TEST RESULTS

NOTE : The 9K~30MHz amplitude of spurious emissions attenuated more than 20 dB below the permissible value is not required in the report.

BELOW 1GHz WORST-CASE DATA

30 MHz – 1GHz data:

GSM1900(Ant0):

CHANNEL BANDWIDTH: 512 ~ 810

MODE	TX channel 661	FREQUENCY RANGE	Below 1000MHz
ENVIRONMENTAL CONDITIONS	23deg. C, 70%RH	INPUT POWER	AC 120V/60HZ
TESTED BY	Jace Hu		
ANTENNA POLARITY & TEST DISTANCE: HORIZONTAL AT 3 M			

Rg	Frequency [MHz]	PK+ Level [dBm]	PK+ Limit [dBm]	PK+ Margin [dB]	Correction [dB]	Polarization	Azimuth [deg]	Antenna Height [m]
1	46.250	-80.97	-13.00	67.97	-5.58	H	1	2
1	69.000	-81.53	-13.00	68.53	-9.72	H	24.6	2
1	102.250	-78.88	-13.00	65.88	-10.80	H	175.2	2
1	156.950	-78.60	-13.00	65.60	-14.06	H	245.8	1
1	295.650	-66.35	-13.00	53.35	-4.82	H	354.9	2
1	430.650	-75.43	-13.00	62.43	-1.17	H	5.2	1

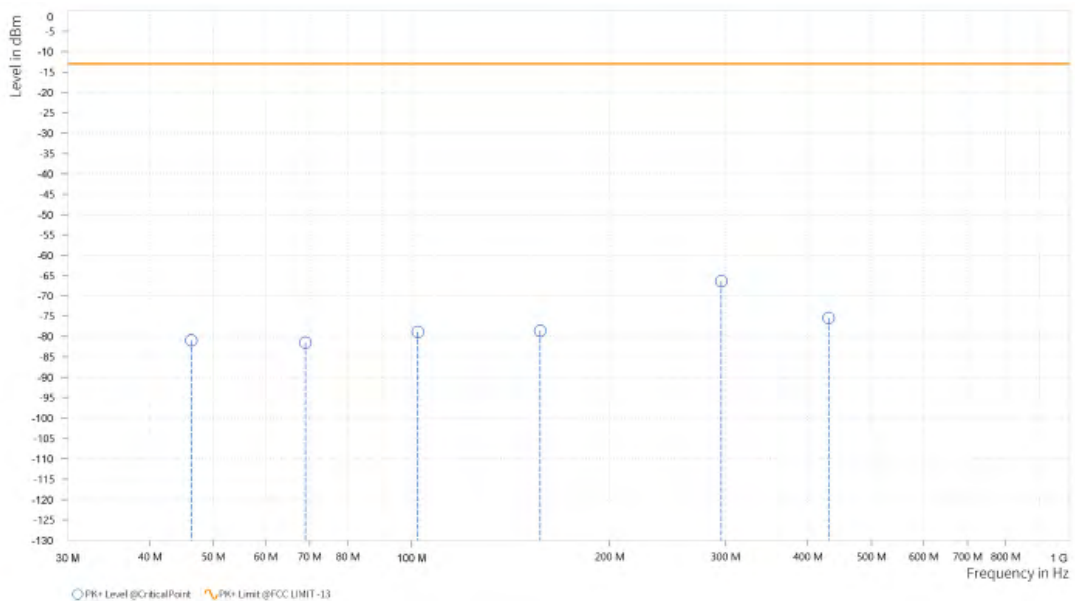



**BUREAU
VERITAS**

Test Report No.: W7L-P23030005RF05

MODE	TX channel 661	FREQUENCY RANGE	Below 1000MHz
ENVIRONMENTAL CONDITIONS	23deg. C, 70%RH	INPUT POWER	AC 120V/60HZ
TESTED BY	Jace Hu		
ANTENNA POLARITY & TEST DISTANCE: VERTICAL AT 3 M			

Rg	Frequency [MHz]	PK+ Level [dBm]	PK+ Limit [dBm]	PK+ Margin [dB]	Correction [dB]	Polarization	Azimuth [deg]	Antenna Height [m]
1	43.450	-81.18	-13.00	68.18	-7.38	V	352.3	1
1	68.150	-77.96	-13.00	64.96	-7.28	V	359.1	1
1	102.500	-77.69	-13.00	64.69	-9.37	V	36.5	2
1	156.700	-79.04	-13.00	66.04	-11.28	V	359	2
1	300.000	-70.09	-13.00	57.09	-6.30	V	359	2
2	482.175	-77.90	-13.00	64.90	-2.21	V	275.8	1

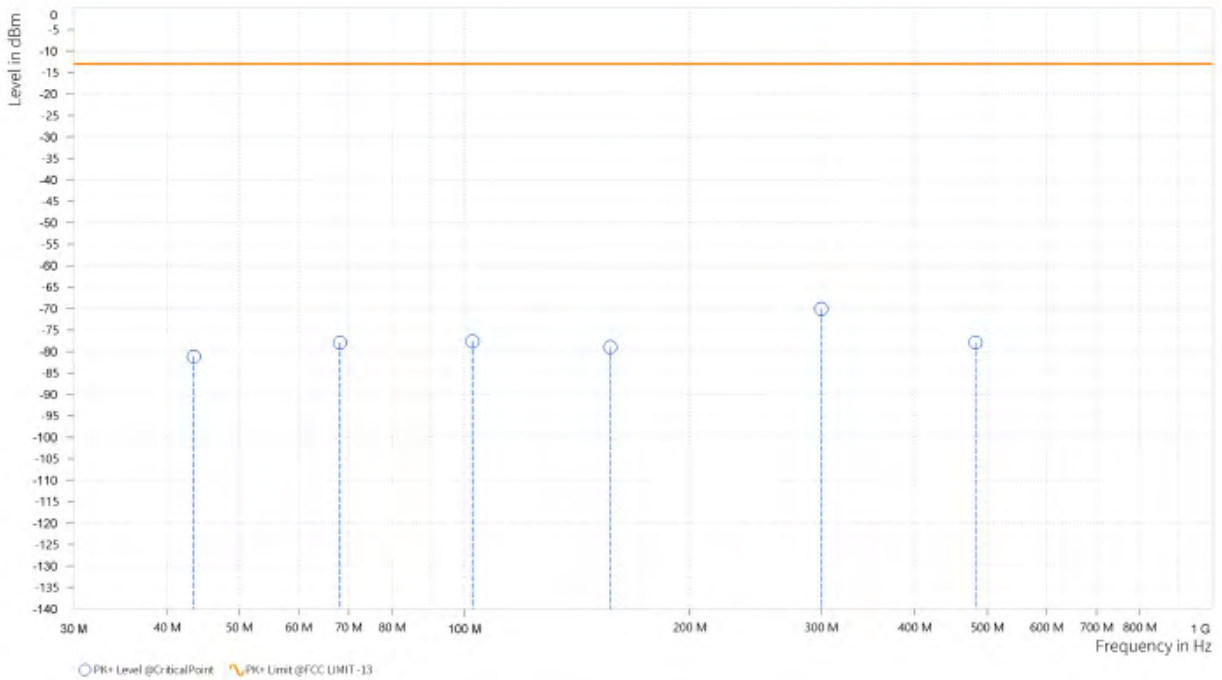



**BUREAU
VERITAS**

Test Report No.: W7L-P23030005RF05

ABOVE 1GHz DATA

Note: For higher frequency, the emission is too low to be detected.

WORST-CASE DATA

GSM 1900(Ant0):

CH 512

MODE	TX channel 512	FREQUENCY RANGE	Above 1000MHz
ENVIRONMENTAL CONDITIONS	23deg. C, 70%RH	INPUT POWER	AC 120V/60HZ
TESTED BY	Jace Hu		
ANTENNA POLARITY & TEST DISTANCE: HORIZONTAL AT 3 M			

Rg	Frequency [MHz]	PK+ Level [dBm]	PK+ Limit [dBm]	PK+ Margin [dB]	Correction [dB]	Polarization	Azimuth [deg]	Antenna Height [m]
4	3,701.000	-50.92	-13.00	37.92	23.94	H	359	2
5	7,253.500	-41.60	-13.00	28.60	34.14	H	0.9	2

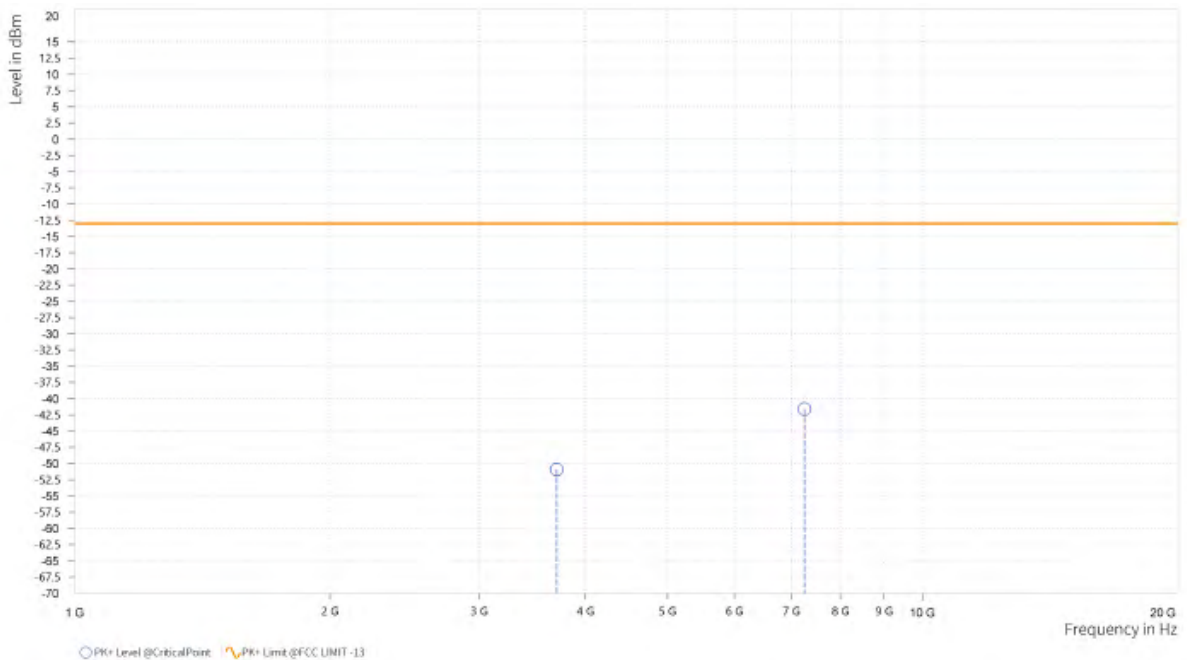



**BUREAU
VERITAS**

Test Report No.: W7L-P23030005RF05

MODE	TX channel 512	FREQUENCY RANGE	Above 1000MHz
ENVIRONMENTAL CONDITIONS	23deg. C, 70%RH	INPUT POWER	AC 120V/60HZ
TESTED BY	Jace Hu		
ANTENNA POLARITY & TEST DISTANCE: VERTICAL AT 3 M			

Rg	Frequency [MHz]	PK+ Level [dBm]	PK+ Limit [dBm]	PK+ Margin [dB]	Correction [dB]	Polarization	Azimuth [deg]	Antenna Height [m]
4	3,699.000	-52.65	-13.00	39.65	23.85	V	183.5	1
5	7,840.000	-42.40	-13.00	29.40	34.02	V	1	1

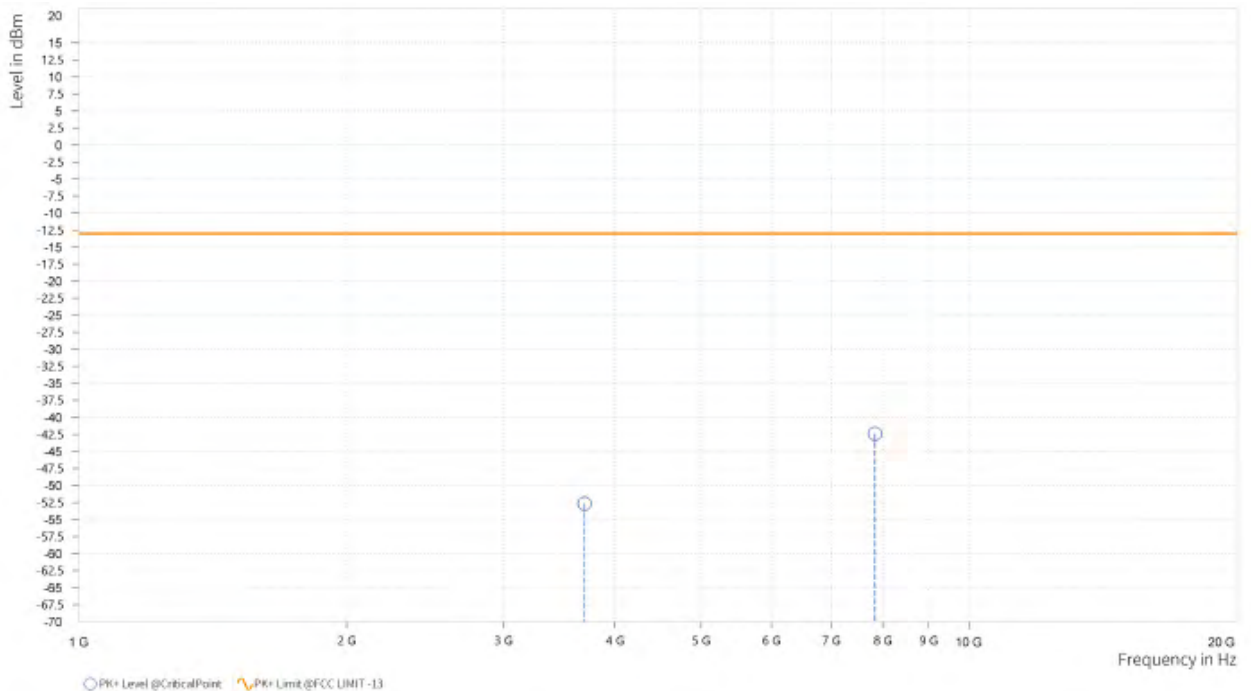



BUREAU VERITAS

Test Report No.: W7L-P23030005RF05

CH 661

MODE	TX channel 661	FREQUENCY RANGE	Above 1000MHz
ENVIRONMENTAL CONDITIONS	23deg. C, 70%RH	INPUT POWER	AC 120V/60HZ
TESTED BY	Jace Hu		
ANTENNA POLARITY & TEST DISTANCE: HORIZONTAL AT 3 M			

Rg	Frequency [MHz]	PK+ Level [dBm]	PK+ Limit [dBm]	PK+ Margin [dB]	Correction [dB]	Polarization	Azimuth [deg]	Antenna Height [m]
4	3,759.500	-48.05	-13.00	35.05	24.51	H	359.1	1
5	7,123.000	-41.87	-13.00	28.87	33.26	H	1	1

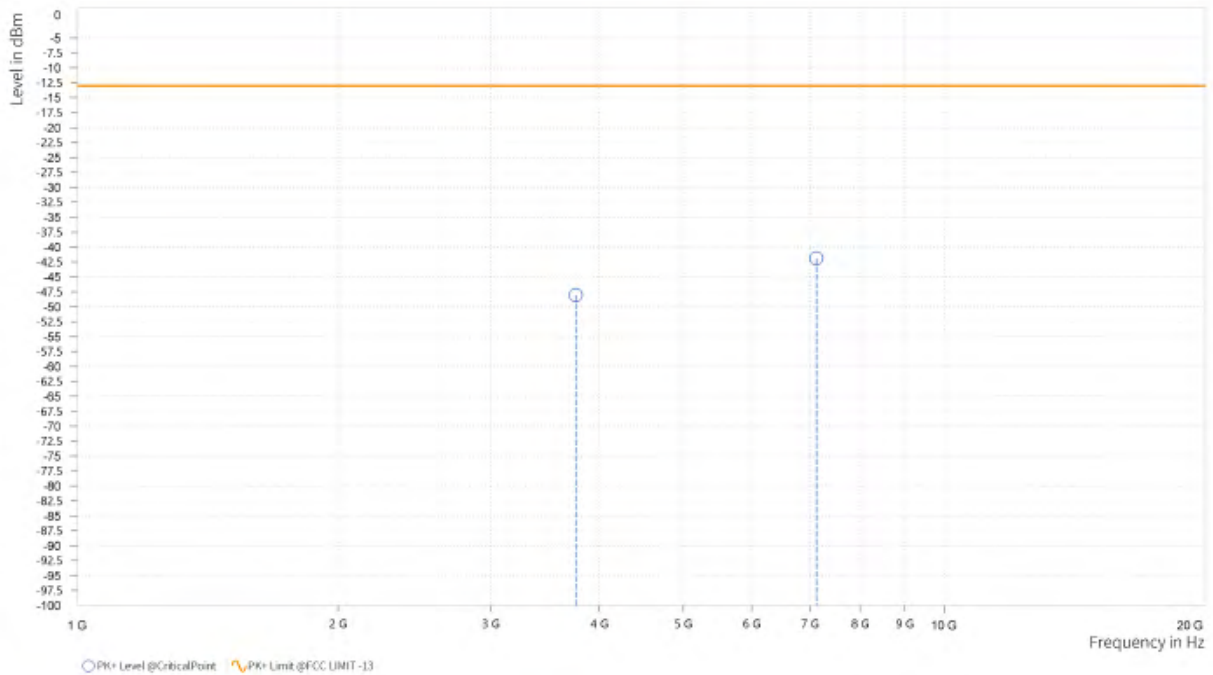



**BUREAU
VERITAS**

Test Report No.: W7L-P23030005RF05

MODE	TX channel 661	FREQUENCY RANGE	Above 1000MHz
ENVIRONMENTAL CONDITIONS	23deg. C, 70%RH	INPUT POWER	AC 120V/60HZ
TESTED BY	Jace Hu		
ANTENNA POLARITY & TEST DISTANCE: VERTICAL AT 3 M			

Rg	Frequency [MHz]	PK+ Level [dBm]	PK+ Limit [dBm]	PK+ Margin [dB]	Correction [dB]	Polarization	Azimuth [deg]	Antenna Height [m]
4	3,759.500	-48.96	-13.00	35.96	24.41	V	359	1
5	7,999.500	-42.91	-13.00	29.91	34.68	V	359	2

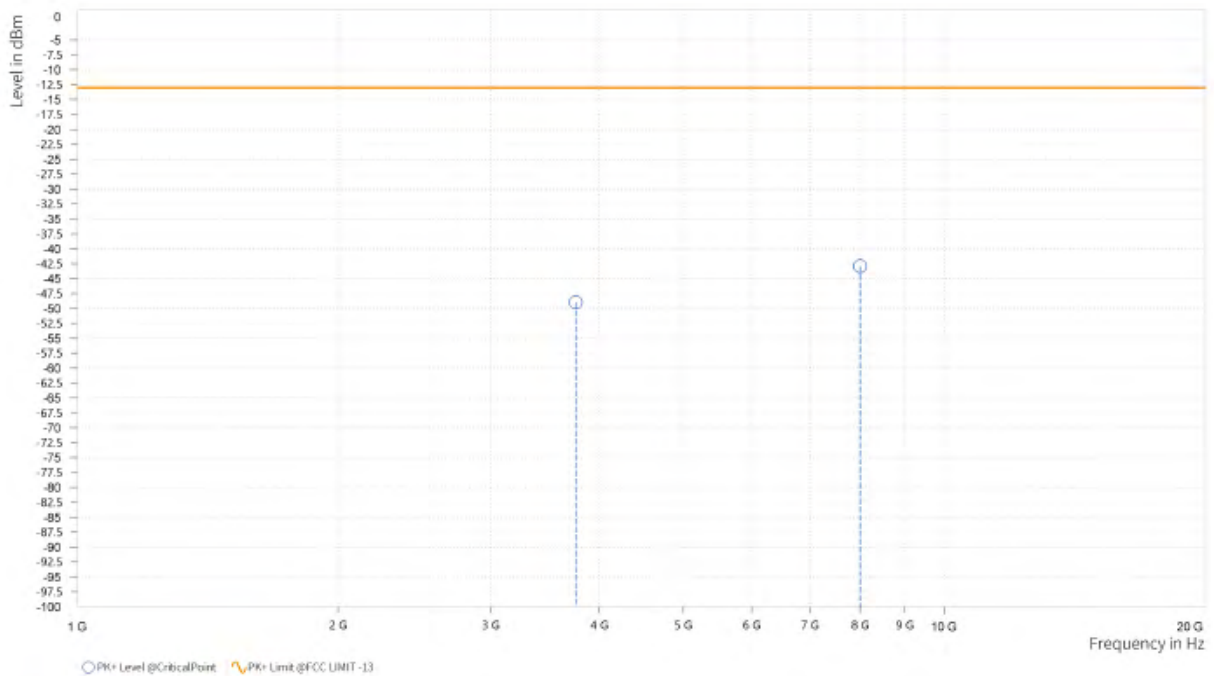



BUREAU VERITAS

Test Report No.: W7L-P23030005RF05

CH 810

MODE	TX channel 810	FREQUENCY RANGE	Above 1000MHz
ENVIRONMENTAL CONDITIONS	23deg. C, 70%RH	INPUT POWER	AC 120V/60HZ
TESTED BY	Jace Hu		
ANTENNA POLARITY & TEST DISTANCE: HORIZONTAL AT 3 M			

Rg	Frequency [MHz]	PK+ Level [dBm]	PK+ Limit [dBm]	PK+ Margin [dB]	Correction [dB]	Polarization	Azimuth [deg]	Antenna Height [m]
4	3,819.500	-50.26	-13.00	37.26	24.64	H	359	1
5	7,912.000	-42.64	-13.00	29.64	34.14	H	270.9	1

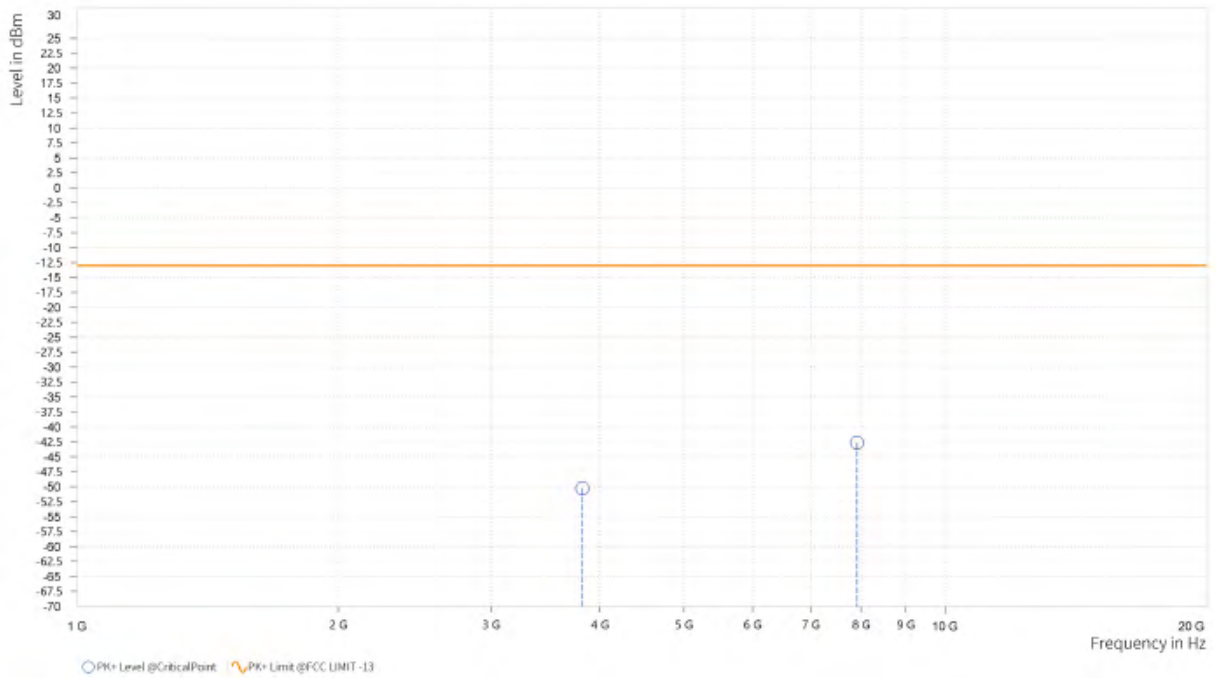



**BUREAU
VERITAS**

Test Report No.: W7L-P23030005RF05

MODE	TX channel 810	FREQUENCY RANGE	Above 1000MHz
ENVIRONMENTAL CONDITIONS	23deg. C, 70%RH	INPUT POWER	AC 120V/60HZ
TESTED BY	Jace Hu		
ANTENNA POLARITY & TEST DISTANCE: VERTICAL AT 3 M			

Rg	Frequency [MHz]	PK+ Level [dBm]	PK+ Limit [dBm]	PK+ Margin [dB]	Correction [dB]	Polarization	Azimuth [deg]	Antenna Height [m]
4	3,819.500	-50.45	-13.00	37.45	24.41	V	1	1
5	7,263.500	-42.71	-13.00	29.71	34.24	V	267.4	1

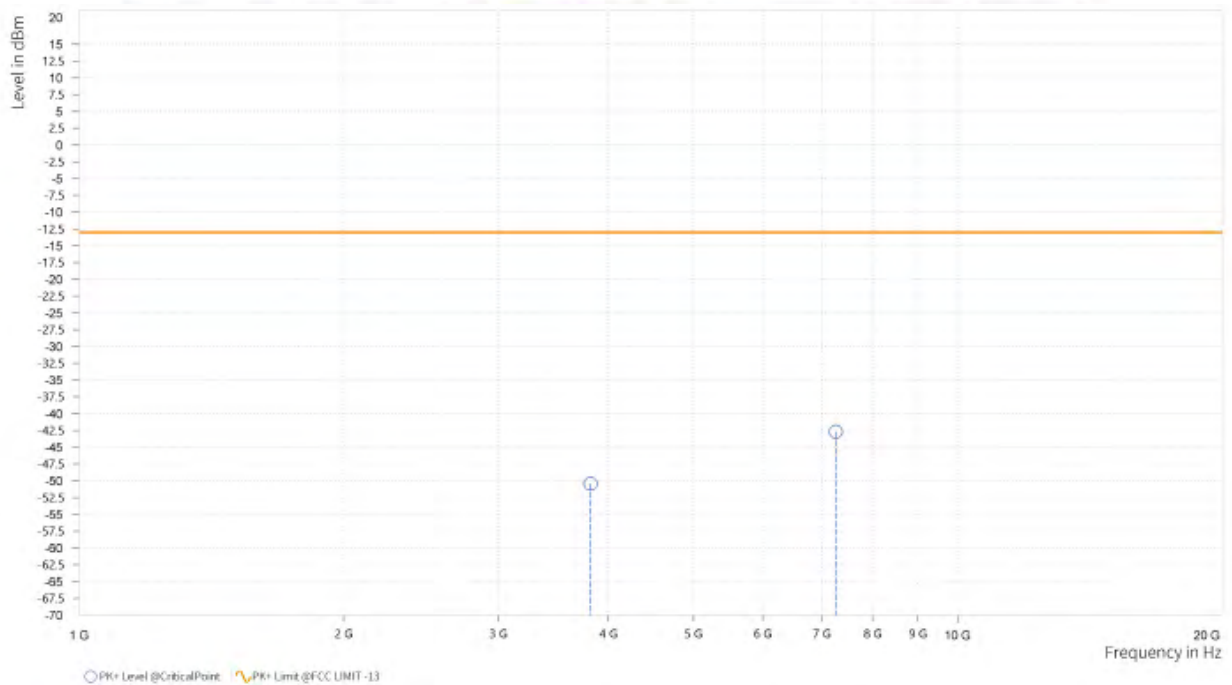



BUREAU VERITAS

Test Report No.: W7L-P23030005RF05

EDGE 1900(Ant0):

CH 512

MODE	TX channel 512	FREQUENCY RANGE	Above 1000MHz
ENVIRONMENTAL CONDITIONS	23deg. C, 70%RH	INPUT POWER	AC 120V/60HZ
TESTED BY	Jace Hu		
ANTENNA POLARITY & TEST DISTANCE: HORIZONTAL AT 3 M			

Rg	Frequency [MHz]	PK+ Level [dBm]	PK+ Limit [dBm]	PK+ Margin [dB]	Correction [dB]	Polarization	Azimuth [deg]	Antenna Height [m]
4	3,700.500	-51.95	-13.00	38.95	23.94	H	359.1	1
5	7,233.000	-42.26	-13.00	29.26	34.15	H	1	2

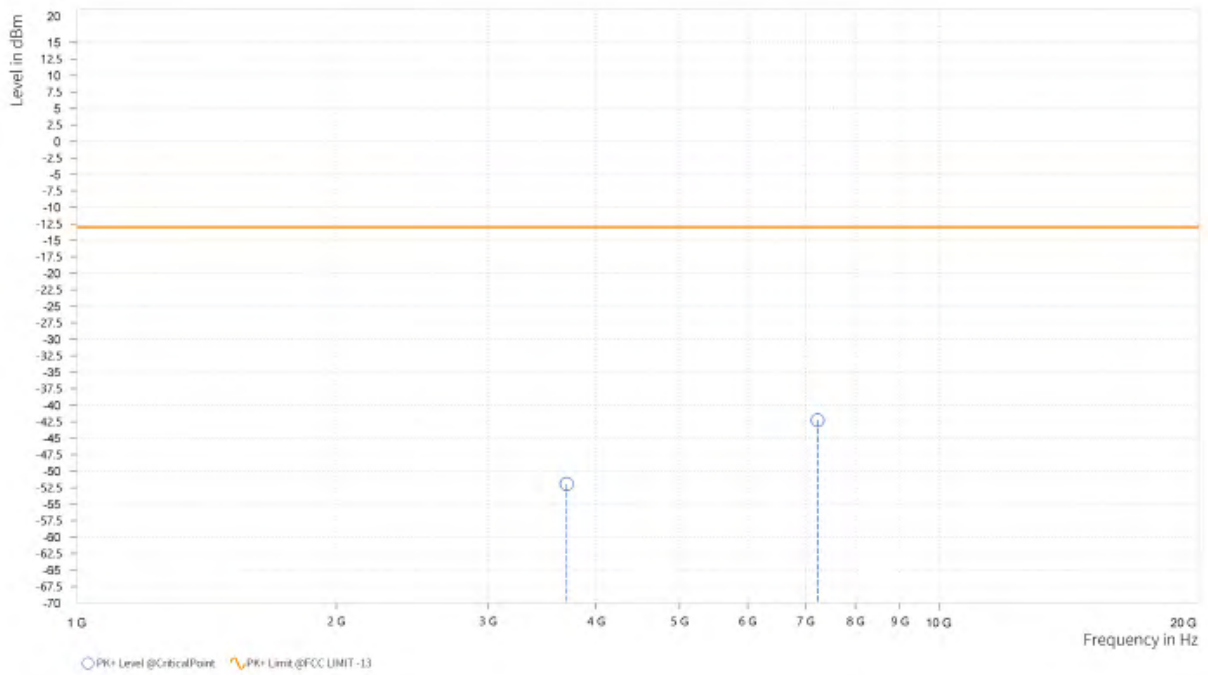



**BUREAU
VERITAS**

Test Report No.: W7L-P23030005RF05

MODE	TX channel 512	FREQUENCY RANGE	Above 1000MHz
ENVIRONMENTAL CONDITIONS	23deg. C, 70%RH	INPUT POWER	AC 120V/60HZ
TESTED BY	Jace Hu		
ANTENNA POLARITY & TEST DISTANCE: VERTICAL AT 3 M			

Rg	Frequency [MHz]	PK+ Level [dBm]	PK+ Limit [dBm]	PK+ Margin [dB]	Correction [dB]	Polarization	Azimuth [deg]	Antenna Height [m]
4	3,700.000	-51.25	-13.00	38.25	23.86	V	359	2
5	7,749.000	-42.29	-13.00	29.29	34.11	V	359	2

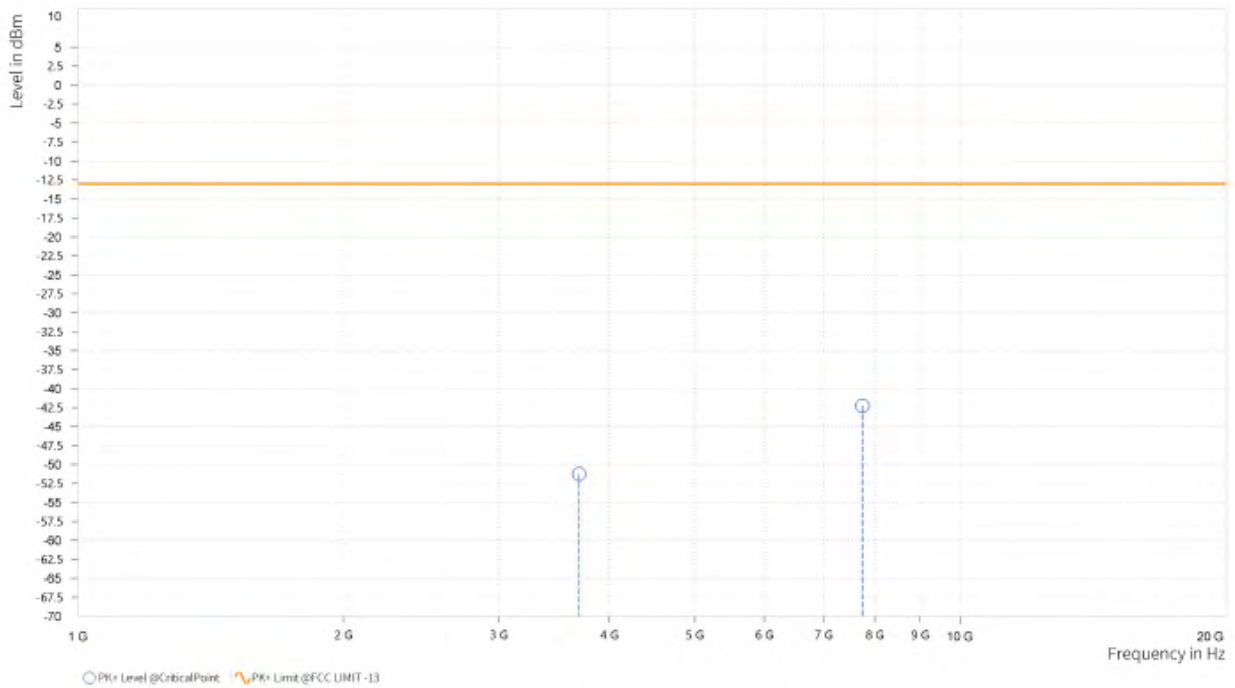



BUREAU VERITAS

Test Report No.: W7L-P23030005RF05

CH 661

MODE	TX channel 661	FREQUENCY RANGE	Above 1000MHz
ENVIRONMENTAL CONDITIONS	23deg. C, 70%RH	INPUT POWER	AC 120V/60HZ
TESTED BY	Jace Hu		
ANTENNA POLARITY & TEST DISTANCE: HORIZONTAL AT 3 M			

Rg	Frequency [MHz]	PK+ Level [dBm]	PK+ Limit [dBm]	PK+ Margin [dB]	Correction [dB]	Polarization	Azimuth [deg]	Antenna Height [m]
4	3,759.000	-51.21	-13.00	38.21	24.51	H	1	2
5	7,904.000	-42.55	-13.00	29.55	34.12	H	359	1

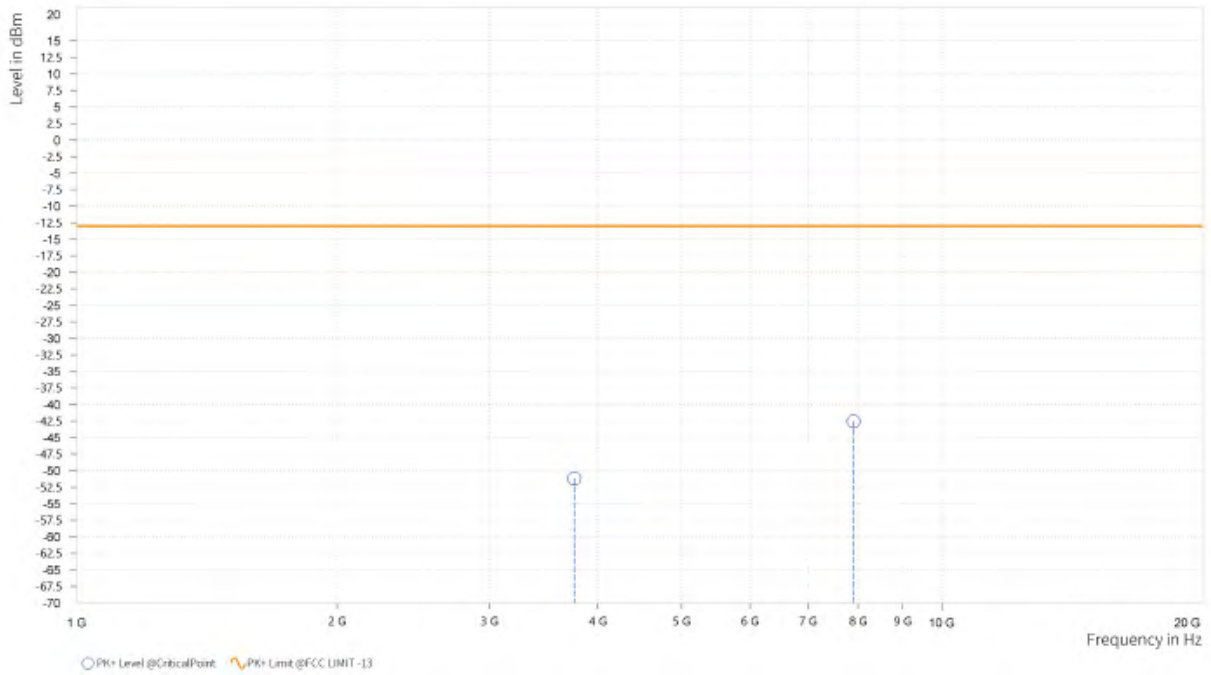



**BUREAU
VERITAS**

Test Report No.: W7L-P23030005RF05

MODE	TX channel 661	FREQUENCY RANGE	Above 1000MHz
ENVIRONMENTAL CONDITIONS	23deg. C, 70%RH	INPUT POWER	AC 120V/60HZ
TESTED BY	Jace Hu		
ANTENNA POLARITY & TEST DISTANCE: VERTICAL AT 3 M			

Rg	Frequency [MHz]	PK+ Level [dBm]	PK+ Limit [dBm]	PK+ Margin [dB]	Correction [dB]	Polarization	Azimuth [deg]	Antenna Height [m]
4	3,760.500	-51.48	-13.00	38.48	24.41	V	359	2
5	7,261.000	-41.42	-13.00	28.42	34.26	V	274.6	1

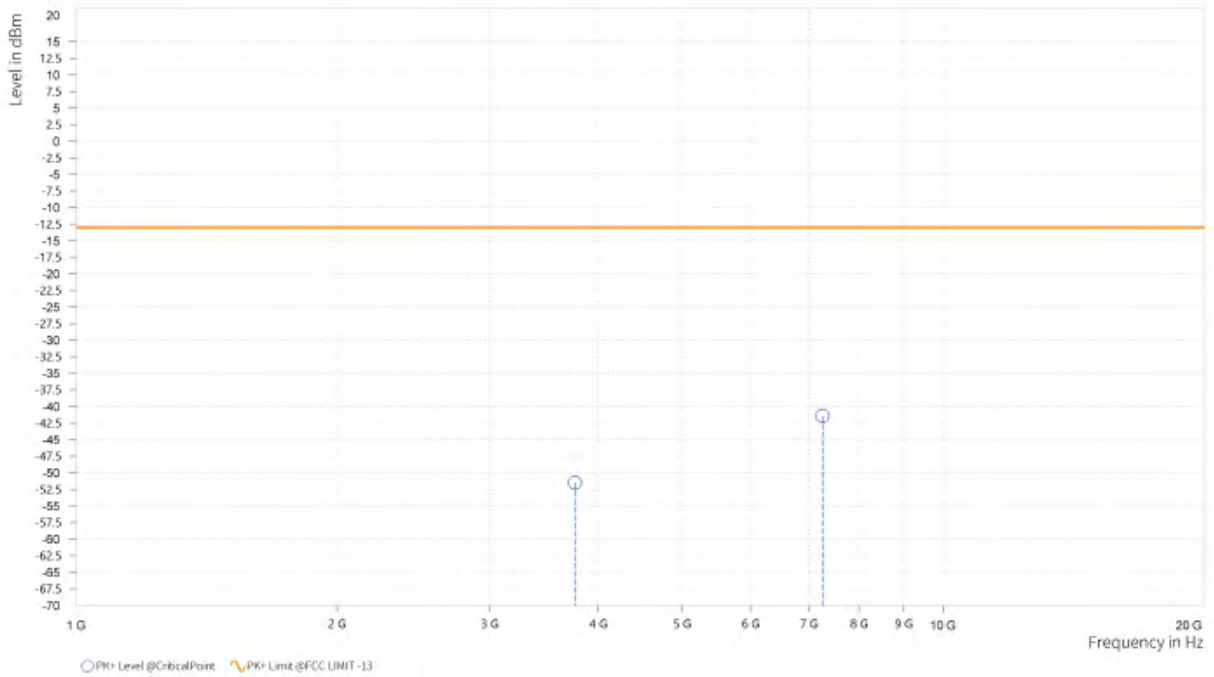



BUREAU VERITAS

Test Report No.: W7L-P23030005RF05

CH 810

MODE	TX channel 810	FREQUENCY RANGE	Above 1000MHz
ENVIRONMENTAL CONDITIONS	23deg. C, 70%RH	INPUT POWER	AC 120V/60HZ
TESTED BY	Jace Hu		
ANTENNA POLARITY & TEST DISTANCE: HORIZONTAL AT 3 M			

Rg	Frequency [MHz]	PK+ Level [dBm]	PK+ Limit [dBm]	PK+ Margin [dB]	Correction [dB]	Polarization	Azimuth [deg]	Antenna Height [m]
4	3,819.500	-48.71	-13.00	35.71	24.64	H	0.9	2
4	5,729.500	-44.66	-13.00	31.66	29.38	H	160.7	2
5	7,222.500	-42.29	-13.00	29.29	34.06	H	75.9	2

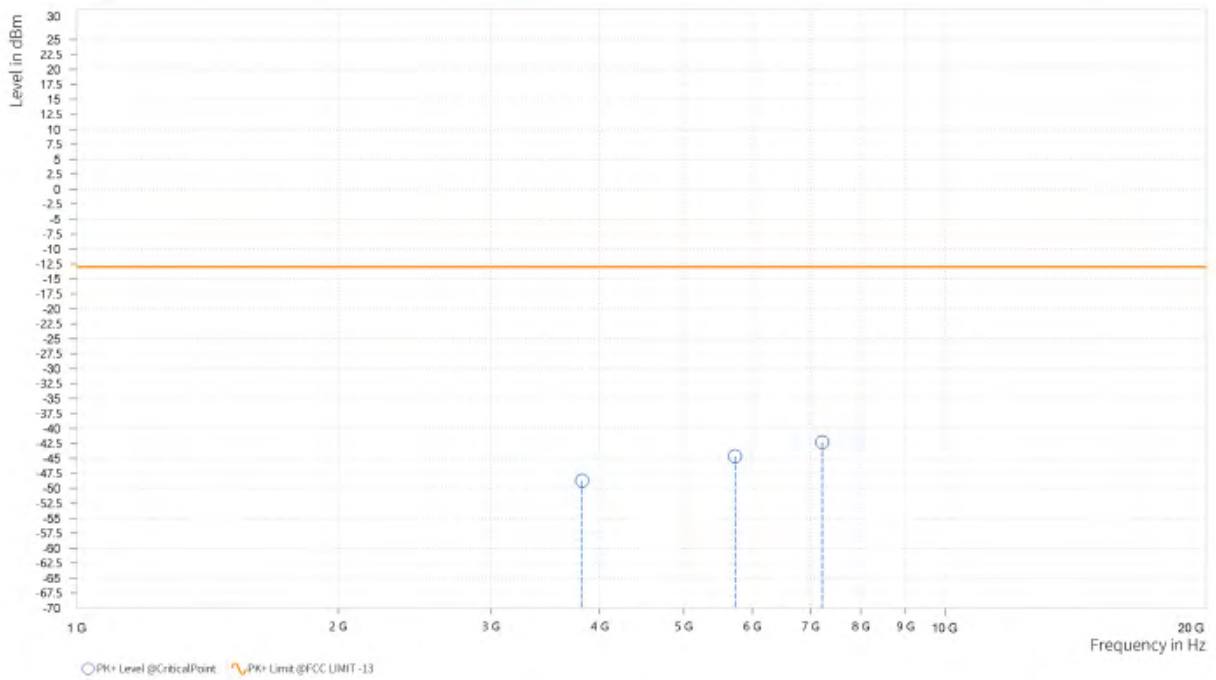



**BUREAU
VERITAS**

Test Report No.: W7L-P23030005RF05

MODE	TX channel 810	FREQUENCY RANGE	Above 1000MHz
ENVIRONMENTAL CONDITIONS	23deg. C, 70%RH	INPUT POWER	AC 120V/60HZ
TESTED BY	Jace Hu		
ANTENNA POLARITY & TEST DISTANCE: VERTICAL AT 3 M			

Rg	Frequency [MHz]	PK+ Level [dBm]	PK+ Limit [dBm]	PK+ Margin [dB]	Correction [dB]	Polarization	Azimuth [deg]	Antenna Height [m]
4	3,819.500	-48.33	-13.00	35.33	24.41	V	1	1
4	5,729.500	-44.79	-13.00	31.79	28.52	V	184.7	1
5	7,915.000	-42.27	-13.00	29.27	34.25	V	359	2

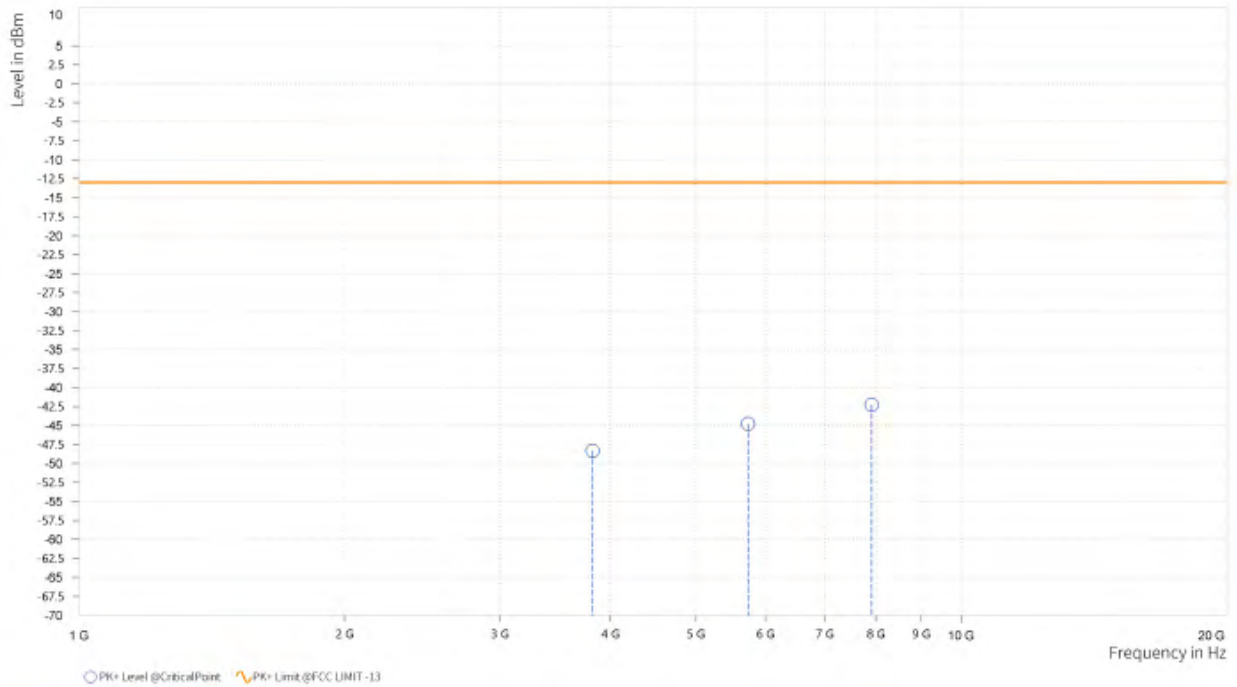



3.7 PEAK TO AVERAGE RATIO

3.7.1 LIMITS OF PEAK TO AVERAGE RATIO MEASUREMENT

In measuring transmissions in this band using an average power technique, the peak to-average ratio (PAR) of the transmission may not exceed 13 dB

3.7.2 TEST SETUP

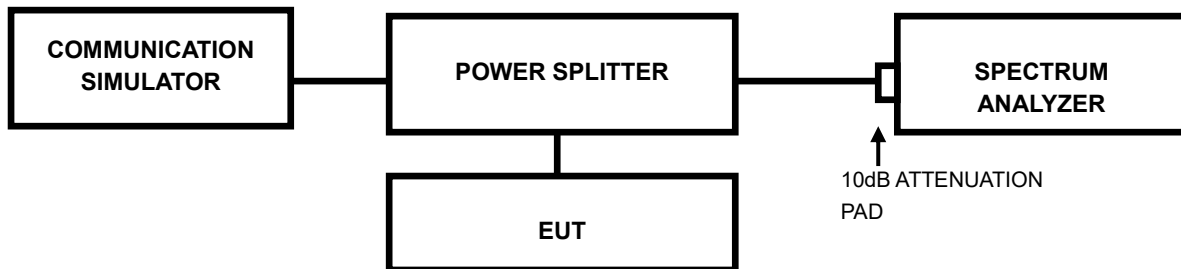

3.7.3 TEST PROCEDURES

1. Set resolution/measurement bandwidth \geq signal's occupied bandwidth;
2. Set the number of counts to a value that stabilizes the measured CCDF curve;
3. Record the maximum PAPR level associated with a probability of 0.1%.



BUREAU
VERITAS

Test Report No.: W7L-P23030005RF05

3.7.4 TEST RESULTS

Please Refer to Appendix Of this test report.



**BUREAU
VERITAS**

Test Report No.: W7L-P23030005RF05

4 INFORMATION ON THE TESTING LABORATORIES

We, BV 7LAYERS COMMUNICATIONS TECHNOLOGY (SHENZHEN) CO. LTD., were founded in 2015 to provide our best service in EMC, Radio, Telecom and Safety consultation. Our laboratories are accredited and approved according to ISO/IEC 17025.

If you have any comments, please feel free to contact us at the following:

Shenzhen EMC/RF Lab:

Tel: +86-755-88696566

Fax: +86-755-88696577

Email: customerservice.sw@bureauveritas.com

Web Site: www.adt.com.tw

The address and road map of all our labs can be found in our web site also.



Test Report No.: W7L-P23030005RF05

5 MODIFICATIONS RECORDERS FOR ENGINEERING CHANGES TO THE EUT BY THE LAB

No any modifications are made to the EUT by the lab during the test.



6 APPENDIX

GSM1900

PEAK-TO-AVERAGE RATIO(CCDF)

Test Result

Band	Channel	Result(dB)	Limit(dB)	Verdict
GSM1900	512	2.6	13	PASS
GSM1900	661	2.6	13	PASS
GSM1900	810	2.6	13	PASS
EGPRS1900	512	5.65	13	PASS
EGPRS1900	661	5.67	13	PASS
EGPRS1900	810	5.64	13	PASS



BUREAU
VERITAS

Test Report No.: W7L-P23030005RF05

Test Graphs

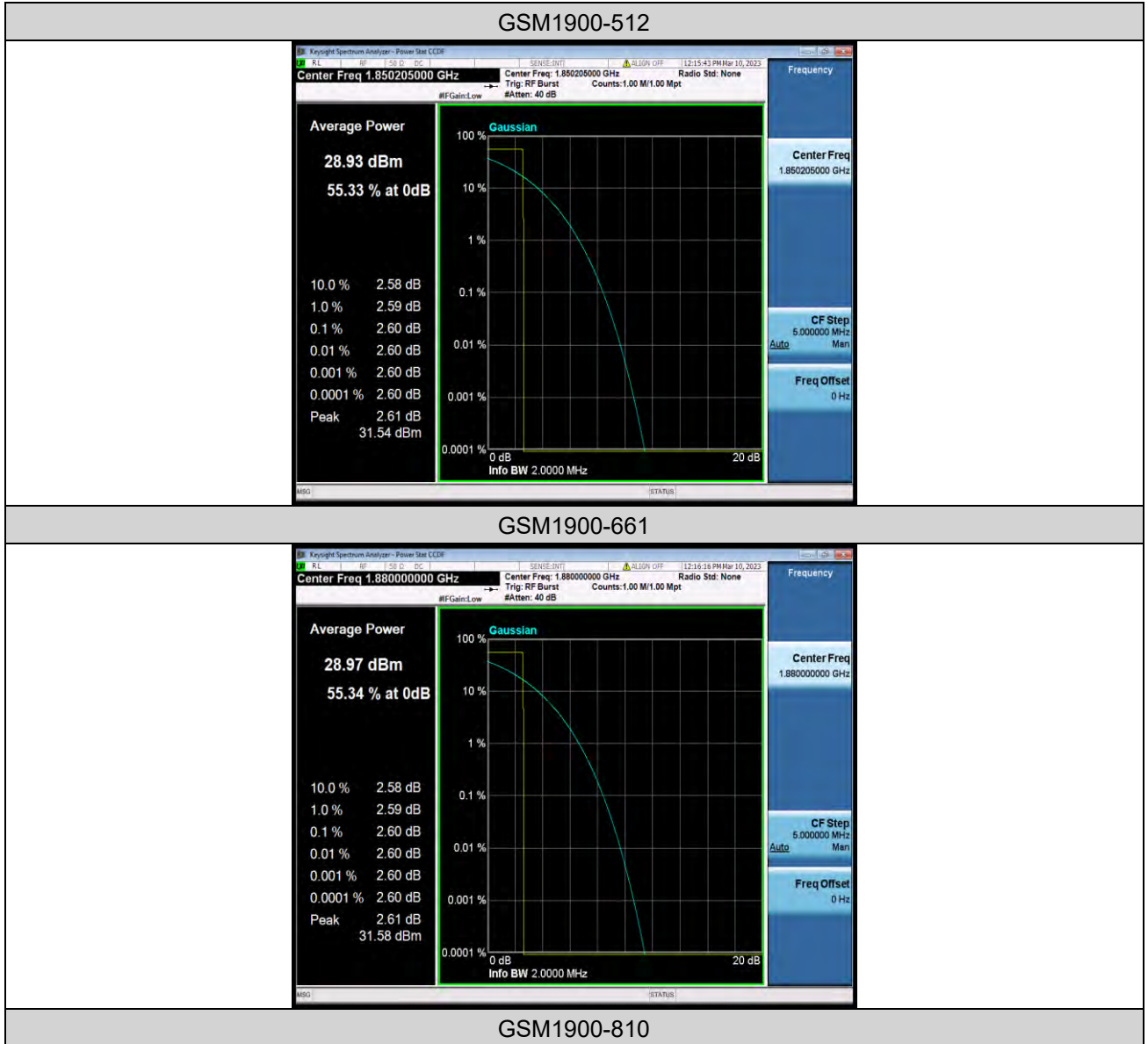



BUREAU VERITAS

Test Report No.: W7L-P23030005RF05



EGPRS1900-512

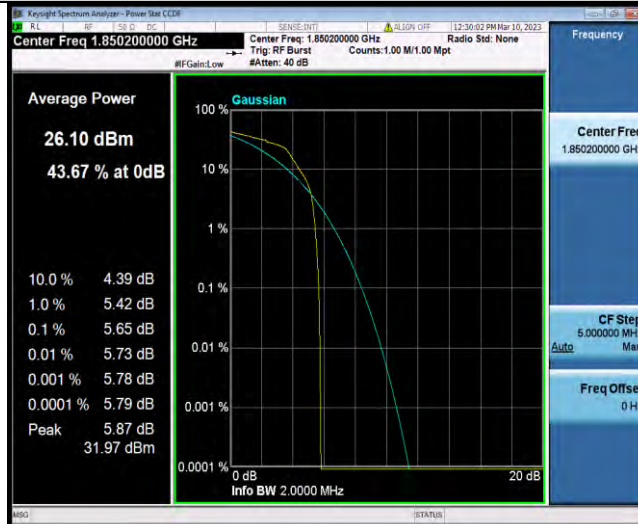

EGPRS1900-661

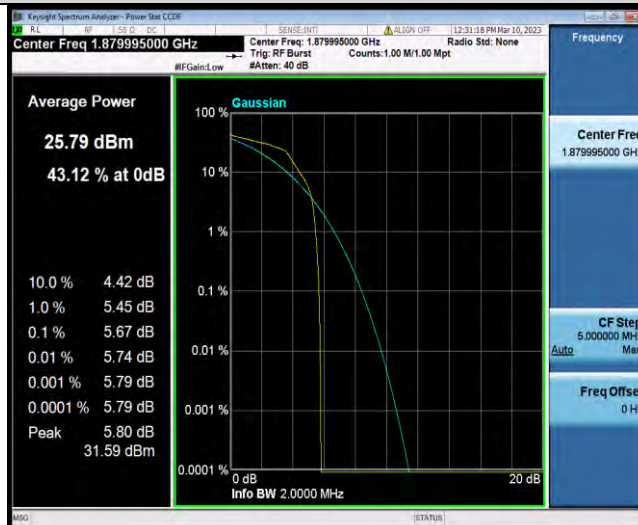

EGPRS1900-810



BUREAU
VERITAS

Test Report No.: W7L-P23030005RF05

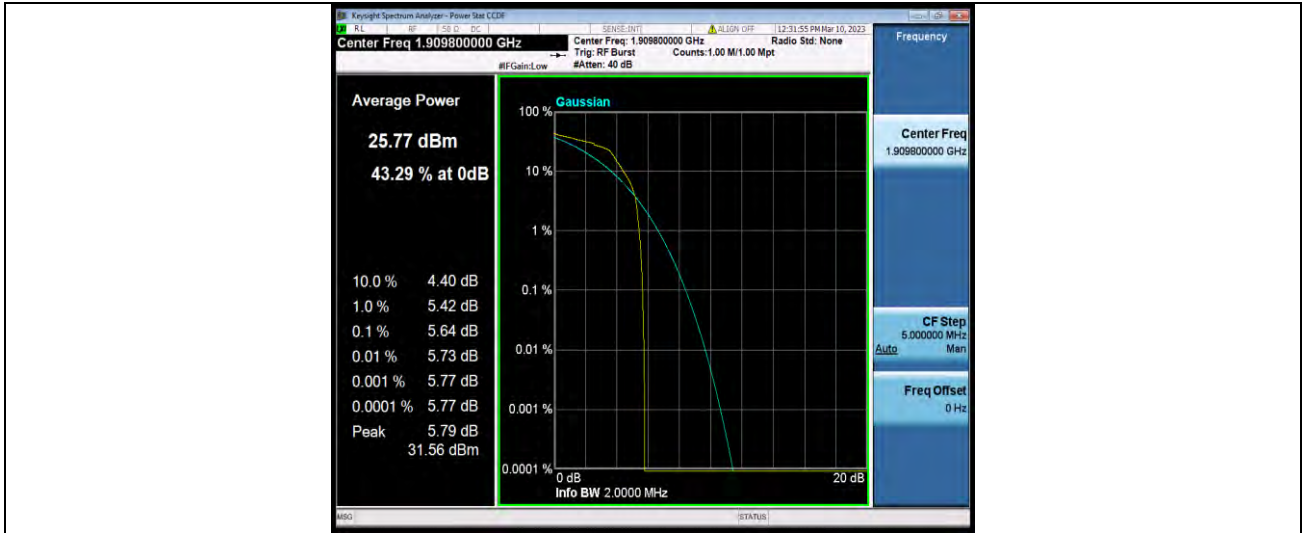



Test Report No.: W7L-P23030005RF05

26DB BANDWIDTH AND OCCUPIED BANDWIDTH

Test Result

Band	Channel	Occupied Bandwidth (MHz)	26dB Bandwidth (MHz)	Limit (MHz)	Verdict
GSM1900	512	0.24735	0.3133	---	PASS
GSM1900	661	0.24459	0.3150	---	PASS
GSM1900	810	0.24572	0.3100	---	PASS
EGPRS1900	512	0.25089	0.3070	---	PASS
EGPRS1900	661	0.24998	0.3101	---	PASS
EGPRS1900	810	0.24956	0.3056	---	PASS



BUREAU
VERITAS

Test Report No.: W7L-P23030005RF05

Test Graphs

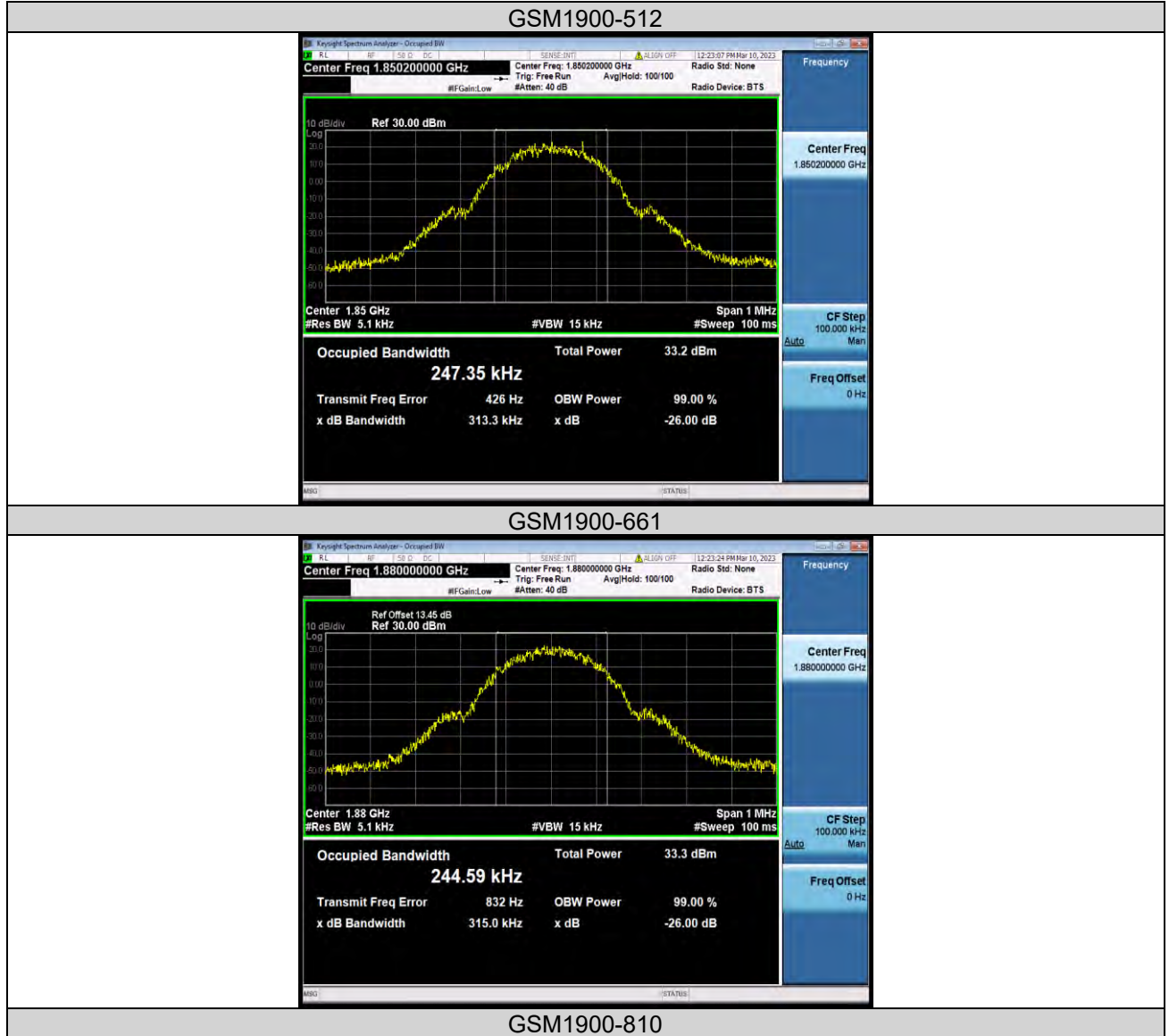



BUREAU VERITAS

Test Report No.: W7L-P23030005RF05

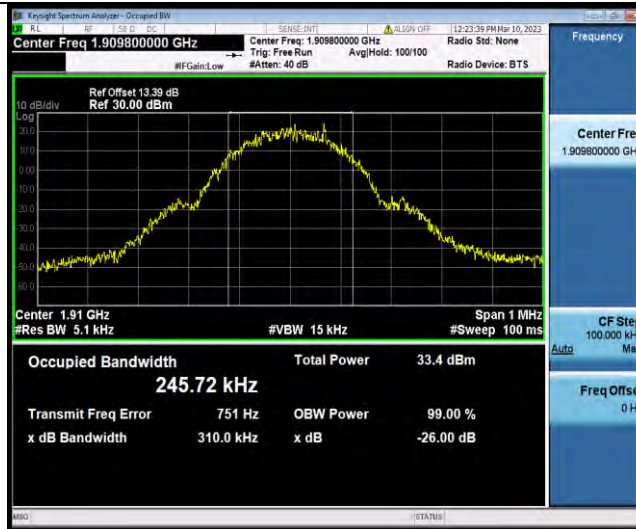

EGPRS1900-512

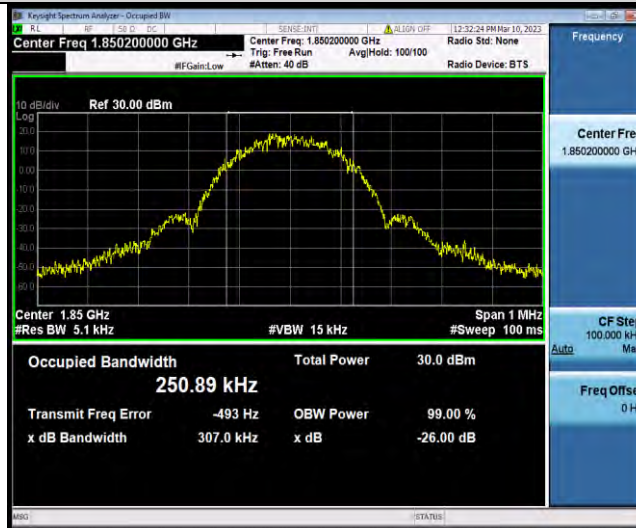

EGPRS1900-661

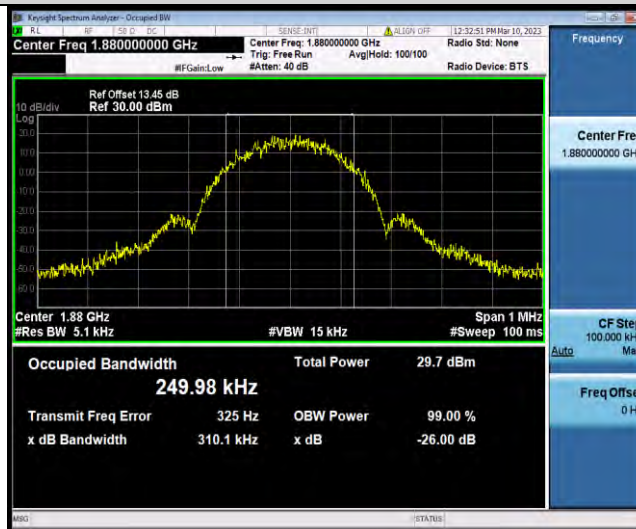

EGPRS1900-810



BUREAU
VERITAS

Test Report No.: W7L-P23030005RF05

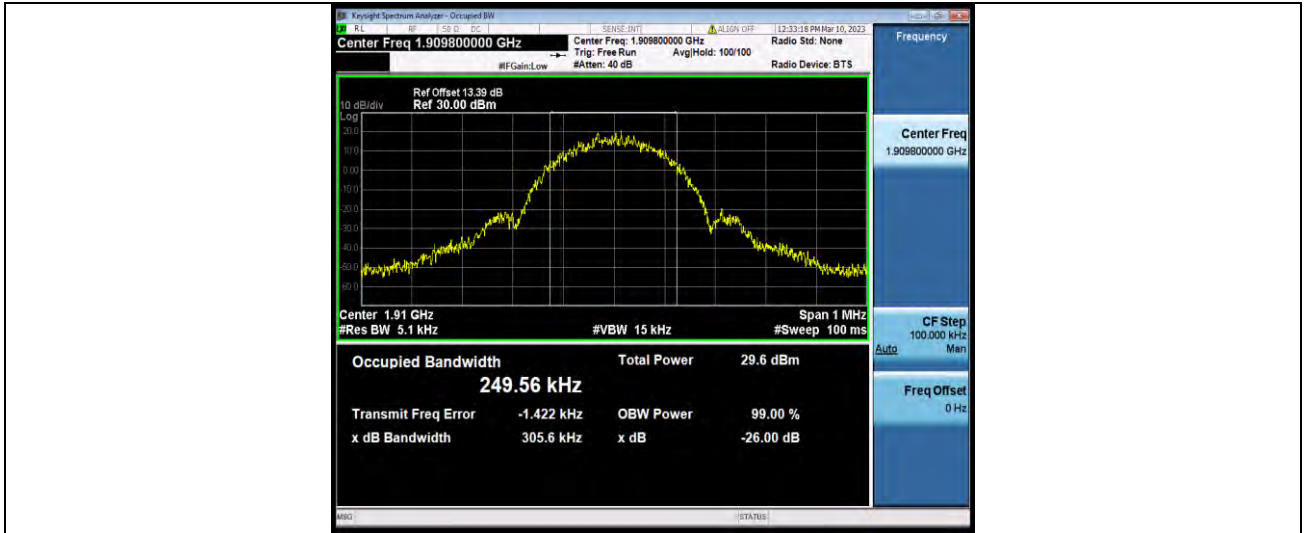



BUREAU
VERITAS

Test Report No.: W7L-P23030005RF05

BAND EDGE

Test Result

Band	Channel	Freq (MHz)	Result (dBm)	Limit(dBm)	Verdict
GSM1900	512	1849.97	-28.17	-13	PASS
GSM1900	810	1910.03	-27.56	-13	PASS
EGPRS1900	512	1849.99	-23.71	-13	PASS
EGPRS1900	810	1910.01	-23.60	-13	PASS



BUREAU VERITAS

Test Report No.: W7L-P23030005RF05

Test Graphs

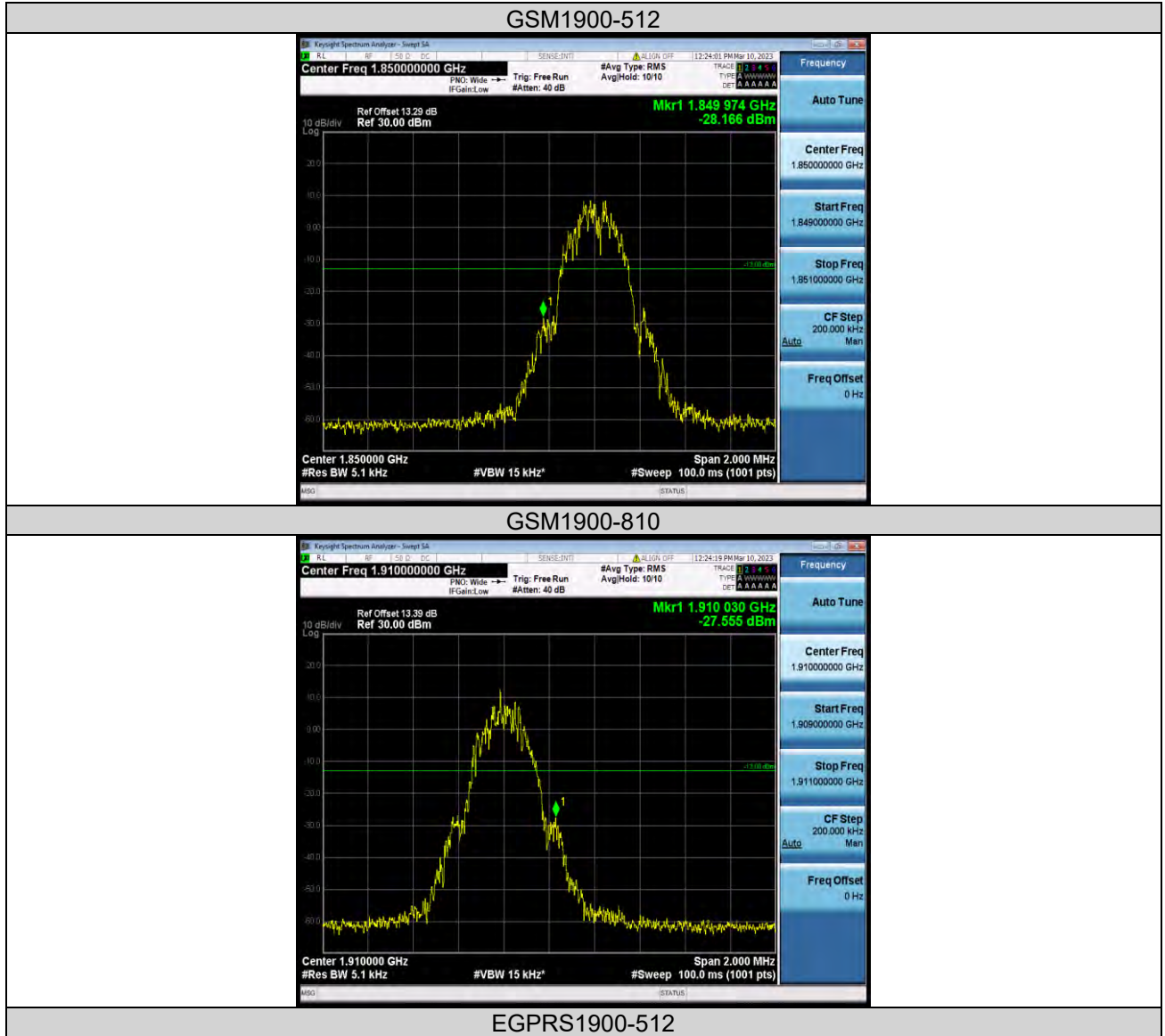

EGPRS1900-512



BUREAU
VERITAS

Test Report No.: W7L-P23030005RF05

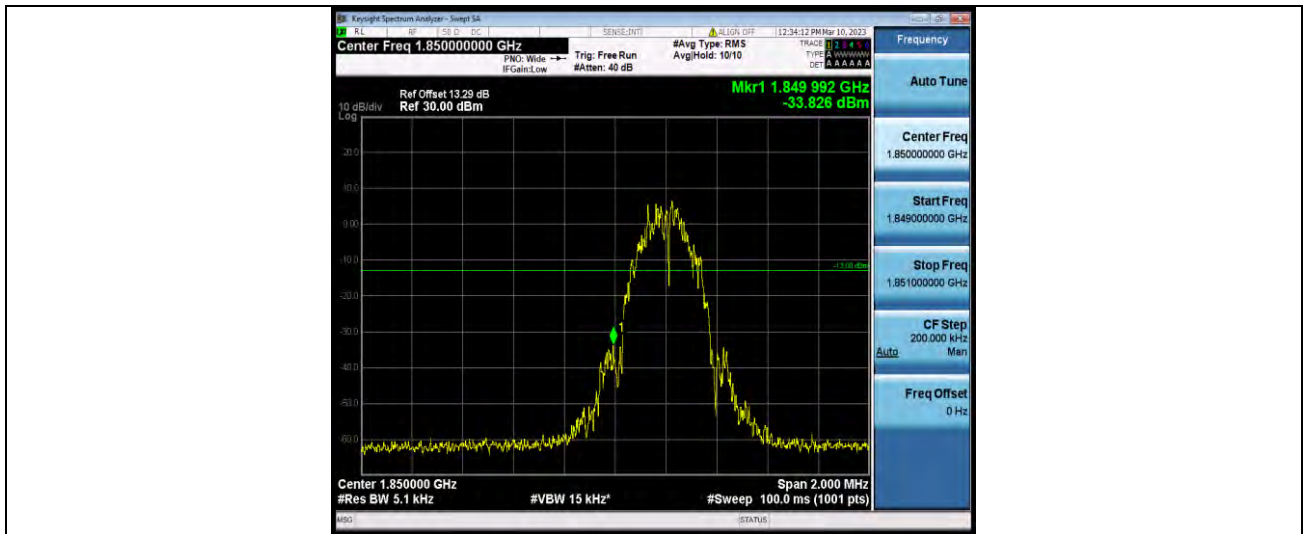

EGPRS1900-810

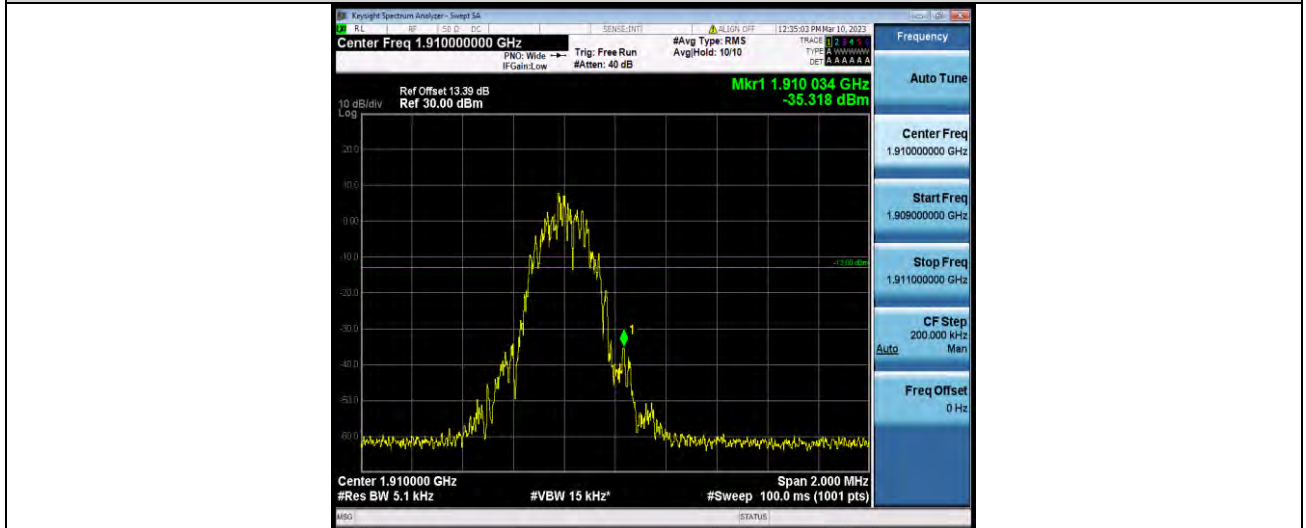



**BUREAU
VERITAS**

Test Report No.: W7L-P23030005RF05

CONDUCTED SPURIOUS EMISSION

Test Result

Band	Channel	Frequency Range(MHz)	Max.Freq. (MHz)	Result (dBm)	Limit (dBm)	Verdict
GSM1900	512	30~1000MHz	797.79	-40.69	-13	PASS
GSM1900	512	1000~20000MHz	19018.33	-32.23	-13	PASS
GSM1900	661	30~1000MHz	881.3	-41.12	-13	PASS
GSM1900	661	1000~20000MHz	19091.8	-31.78	-13	PASS
GSM1900	810	30~1000MHz	886.09	-40.56	-13	PASS
GSM1900	810	1000~20000MHz	19090.53	-32.02	-13	PASS
EGPRS1900	512	30~1000MHz	765.45	-40.72	-13	PASS
EGPRS1900	512	1000~20000MHz	19946.17	-32.06	-13	PASS
EGPRS1900	661	30~1000MHz	941.74	-40.93	-13	PASS
EGPRS1900	661	1000~20000MHz	3817.07	-31.79	-13	PASS
EGPRS1900	810	30~1000MHz	903.55	-40.78	-13	PASS
EGPRS1900	810	1000~20000MHz	19196.93	-32.04	-13	PASS



BUREAU
VERITAS

Test Report No.: W7L-P23030005RF05

Test Graphs

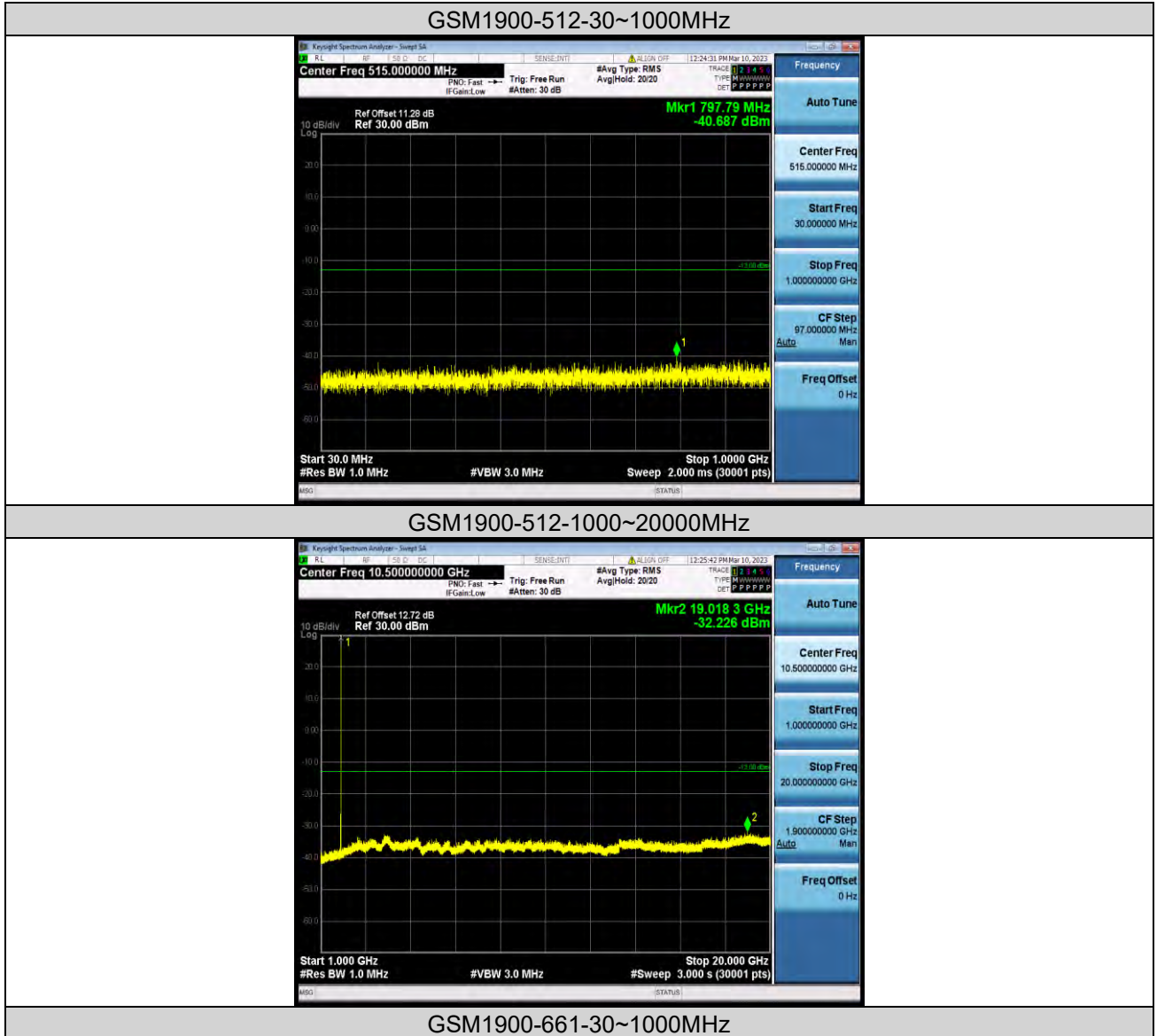



BUREAU VERITAS

Test Report No.: W7L-P23030005RF05

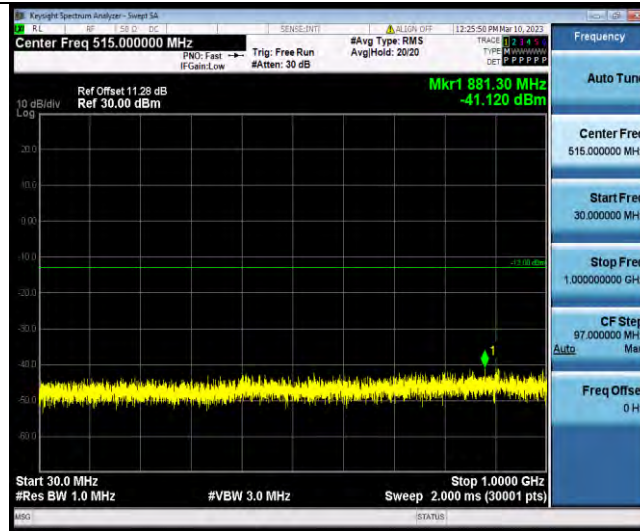

GSM1900-661-1000~20000MHz

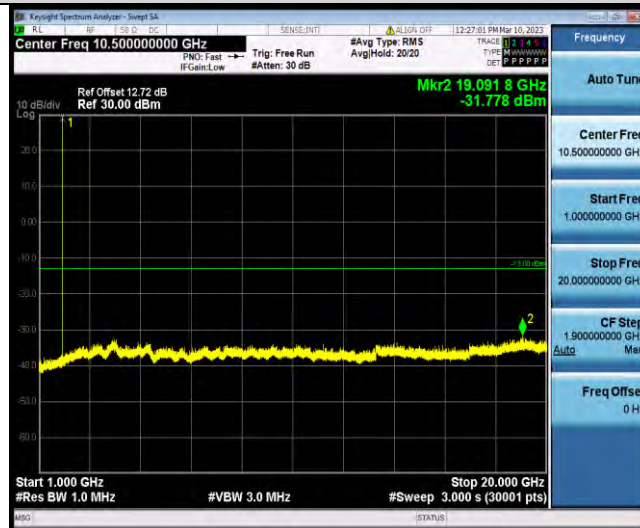

GSM1900-810-30~1000MHz

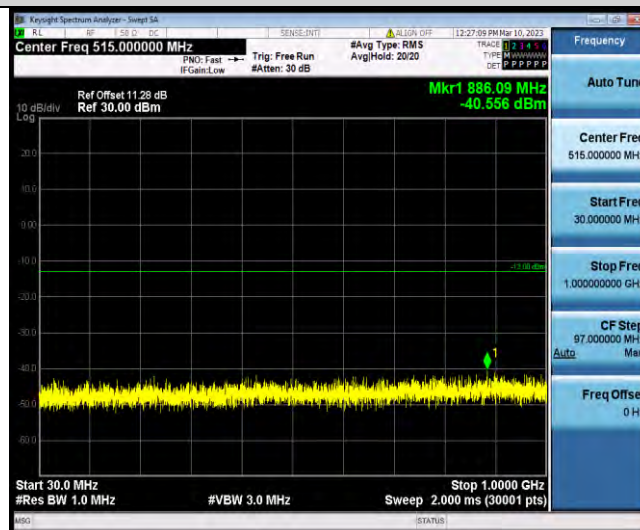

GSM1900-810-1000~20000MHz



BUREAU VERITAS

Test Report No.: W7L-P23030005RF05



EGPRS1900-512-30~1000MHz

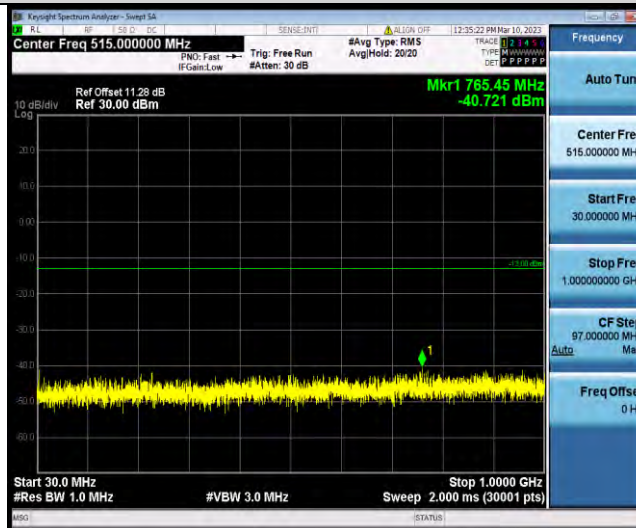

EGPRS1900-512-1000~2000MHz



EGPRS1900-661-30~1000MHz



BUREAU VERITAS

Test Report No.: W7L-P23030005RF05

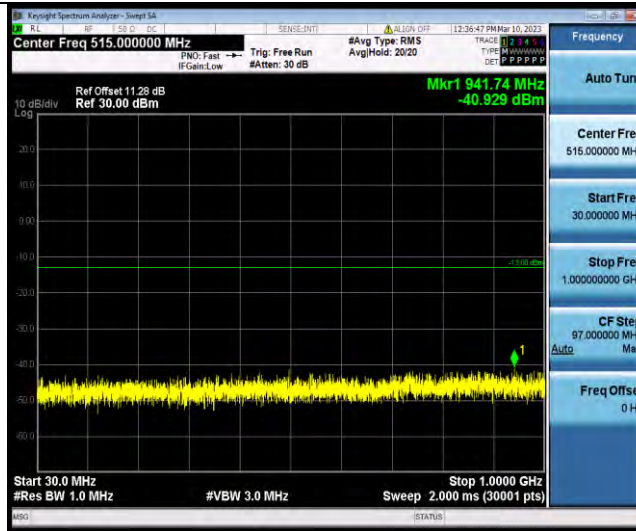

EGPRS1900-661-1000~20000MHz



EGPRS1900-810-30~1000MHz

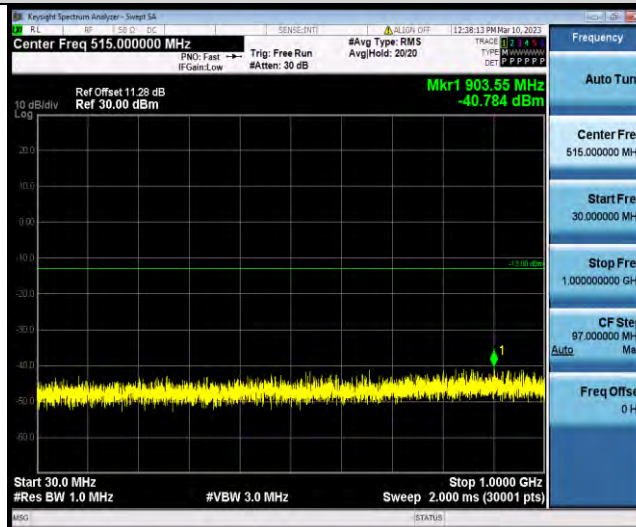

EGPRS1900-810-1000~20000MHz



**BUREAU
VERITAS**

Test Report No.: W7L-P23030005RF05



FREQUENCY STABILITY

Test Result

Voltage							
Band	Channel	Voltage [Vdc]	Temperature (°C)	Deviation (Hz)	Deviation (ppm)	Limit (ppm)	Verdict
GSM1900	512	LV	NT	4.75	0.002567	±2.5	PASS
GSM1900	512	NV	NT	6.49	0.003508	±2.5	PASS
GSM1900	512	HV	NT	4.71	0.002546	±2.5	PASS
GSM1900	661	LV	NT	2.58	0.001372	±2.5	PASS
GSM1900	661	NV	NT	5.88	0.003128	±2.5	PASS
GSM1900	661	HV	NT	4.13	0.002197	±2.5	PASS
GSM1900	810	LV	NT	5.42	0.002838	±2.5	PASS
GSM1900	810	NV	NT	2.26	0.001183	±2.5	PASS
GSM1900	810	HV	NT	2.32	0.001215	±2.5	PASS

Temperature							
Band	Channel	Voltage [Vdc]	Temperature (°C)	Deviation (Hz)	Deviation (ppm)	Limit (ppm)	Verdict
GSM1900	512	NV	-30	4.13	0.002232	±2.5	PASS
GSM1900	512	NV	-20	-3.45	-0.001865	±2.5	PASS
GSM1900	512	NV	-10	10.36	0.005599	±2.5	PASS
GSM1900	512	NV	0	3.91	0.002113	±2.5	PASS
GSM1900	512	NV	10	4.07	0.002200	±2.5	PASS
GSM1900	512	NV	20	-4.84	-0.002616	±2.5	PASS
GSM1900	512	NV	30	10.62	0.005740	±2.5	PASS
GSM1900	512	NV	40	-3.39	-0.001832	±2.5	PASS



GSM1900	512	NV	50	5.36	0.002897	±2.5	PASS
GSM1900	661	NV	-30	1.26	0.000670	±2.5	PASS
GSM1900	661	NV	-20	0.32	0.000170	±2.5	PASS
GSM1900	661	NV	-10	7.04	0.003745	±2.5	PASS
GSM1900	661	NV	0	0.19	0.000101	±2.5	PASS
GSM1900	661	NV	10	3.07	0.001633	±2.5	PASS
GSM1900	661	NV	20	-8.10	-0.004309	±2.5	PASS
GSM1900	661	NV	30	1.55	0.000824	±2.5	PASS
GSM1900	661	NV	40	4.65	0.002473	±2.5	PASS
GSM1900	661	NV	50	-2.94	-0.001564	±2.5	PASS
GSM1900	810	NV	-30	2.23	0.001168	±2.5	PASS
GSM1900	810	NV	-20	6.04	0.003163	±2.5	PASS
GSM1900	810	NV	-10	0.90	0.000471	±2.5	PASS
GSM1900	810	NV	0	0.97	0.000508	±2.5	PASS
GSM1900	810	NV	10	-2.71	-0.001419	±2.5	PASS
GSM1900	810	NV	20	4.10	0.002147	±2.5	PASS
GSM1900	810	NV	30	-5.94	-0.003110	±2.5	PASS
GSM1900	810	NV	40	5.36	0.002807	±2.5	PASS
GSM1900	810	NV	50	5.26	0.002754	±2.5	PASS

Note: LV = Low voltage(3.5V); NV = Normal voltage(3.8V); HV = High voltage(4.2V);NT = Normal temperature (25°C).

MAX Deviation calculation

Frequency Stability	Frequency (MHz)	Limit Line(MHz)	Result
$f_L - \text{MAX}(\Delta f) $	1850.076325	≥ 1850	PASS
$f_H - \text{MAX}(\Delta f) $	1909.922860	≤ 1910	

- Note :
- $|\text{MAX}(\Delta f)|$ = Max Deviation
 - f_L = Occ low channel $f_L(-13\text{dBm/MHz})$
 - f_H = Occ High channel $f_H(-13\text{dBm/MHz})$
 - $|\text{MAX}(\Delta f)|$ = 10.62Hz.

---END---