



# FCC RF Test Report

**APPLICANT** : Xiaomi Communications Co., Ltd.  
**EQUIPMENT** : Mobile Phone  
**BRAND NAME** : Redmi  
**MODEL NAME** : 23090RA98G  
**FCC ID** : 2AFZZRA98G  
**STANDARD** : 47 CFR Part 2, 27 Subpart O (3700-3980MHz)  
**CLASSIFICATION** : PCS Licensed Transmitter Held to Ear (PCE)  
**TEST DATE(S)** : Aug. 14, 2023 ~ Aug 20, 2023

We, Sporton International Inc. (ShenZhen), would like to declare that the tested sample has been evaluated in accordance with the procedures given in ANSI C63.26-2015 and shown compliance with the applicable technical standards.

The test results in this report apply exclusively to the tested model / sample. Without written approval of Sporton International Inc. (ShenZhen), the test report shall not be reproduced except in full.

Jason Jia



Approved by: Jason Jia

**Sporton International Inc. (ShenZhen)**

**1/F, 2/F, Bldg 5, Shiling Industrial Zone, Xinwei Village, Xili, Nanshan, Shenzhen, 518055**

**People's Republic of China**



TABLE OF CONTENTS

REVISION HISTORY...3
SUMMARY OF TEST RESULT...4
1 GENERAL DESCRIPTION...5
1.1 Applicant...5
1.2 Manufacturer...5
1.3 Product Feature of Equipment Under Test...5
1.4 Product Specification of Equipment Under Test...6
1.5 Modification of EUT...6
1.6 Maximum EIRP and Emission Designator...7
1.7 Testing Location...8
1.8 Test Software...8
1.9 Applicable Standards...8
2 TEST CONFIGURATION OF EQUIPMENT UNDER TEST...9
2.1 Test Mode...9
2.2 Connection Diagram of Test System...10
2.3 Support Unit used in test configuration and system...10
2.4 Measurement Results Explanation Example...10
2.5 Frequency List of Low/Middle/High Channels...11
3 CONDUCTED TEST ITEMS...12
3.1 Measuring Instruments...12
3.2 Test Setup...12
3.3 Test Result of Conducted Test...12
3.4 Conducted Output Power and EIRP...13
3.5 Peak-to-Average Ratio...14
3.6 Occupied Bandwidth...15
3.7 Conducted Band Edge...16
3.8 Conducted Spurious Emission...17
3.9 Frequency Stability...18
4 RADIATED TEST ITEMS...19
4.1 Measuring Instruments...19
4.2 Test Setup...19
4.3 Test Result of Radiated Test...20
4.4 Radiated Spurious Emission...21
5 LIST OF MEASURING EQUIPMENT...22
6 MEASUREMENT UNCERTAINTY...23
APPENDIX A. TEST RESULTS OF CONDUCTED TEST
APPENDIX B. TEST RESULTS OF RADIATED TEST
APPENDIX C. TEST SETUP PHOTOGRAPHS



### REVISION HISTORY

REPORT NO.	VERSION	DESCRIPTION	ISSUED DATE
FG380206G	Rev. 01	Initial issue of report	Sep. 15, 2023



### SUMMARY OF TEST RESULT

Report Section	FCC Rule	Description	Limit	Result	Remark
3.4	§2.1046	Conducted Output Power	Reporting Only	PASS	-
	§27.50(j)(3)	Equivalent Isotropic Radiated Power (5G NR n77, n78)	EIRP < 1Watt		
3.5	§27.50(j)(4)	Peak-to-Average Ratio	<13 dB	PASS	-
3.6	§2.1049	Occupied Bandwidth	Reporting Only	PASS	-
3.7	§2.1051 §27.53(l)(2)	Conducted Band Edge Measurement (5G NR n77, n78)	< 43+10log <sub>10</sub> (P[Watts])	PASS	-
3.8	§2.1051 §27.53(l)(2)	Conducted Spurious Emission (5G NR n77, n78)	< 43+10log <sub>10</sub> (P[Watts])	PASS	-
3.9	§27.54	Frequency Stability Temperature & Voltage	Within Authorized Band	PASS	-
4.4	§2.1053 §27.53(l)(2)	Radiated Spurious Emission (5G NR n77, n78)	< 43+10log <sub>10</sub> (P[Watts])	PASS	Under limit 31.30 dB at 10122.36 MHz

**Conformity Assessment Condition:**

- The test results (PASS/FAIL) with all measurement uncertainty excluded are presented against the regulation limits or in accordance with the requirements stipulated by the applicant/manufacturer who shall bear all the risks of non-compliance that may potentially occur if measurement uncertainty is taken into account.
- The measurement uncertainty please refer to each test result in the section "Measurement Uncertainty"

**Disclaimer:**

The product specifications of the EUT presented in the test report that may affect the test assessments are declared by the manufacturer who shall take full responsibility for the authenticity.



# 1 General Description

## 1.1 Applicant

Xiaomi Communications Co., Ltd.

#019, 9th Floor, Building 6, 33 Xi'erqi Middle Road, Haidian District, Beijing, China, 100085

## 1.2 Manufacturer

Xiaomi Communications Co., Ltd.

#019, 9th Floor, Building 6, 33 Xi'erqi Middle Road, Haidian District, Beijing, China, 100085

## 1.3 Product Feature of Equipment Under Test

Product Feature	
Equipment	Mobile Phone
Brand Name	Redmi
Model Name	23090RA98G
FCC ID	2AFZZRA98G
IMEI Code	Conducted : 864595060044447/864595060044454 Radiation : 864595060044405/864595060044413
HW Version	1351N16UM0A01
SW Version	MIUI 14
EUT Stage	Identical Prototype



### 1.4 Product Specification of Equipment Under Test

Standards-related Product Specification	
<b>Tx/Rx Frequency</b>	5G NR n77: 3700 MHz ~ 3980 MHz 5G NR n78: 3700 MHz ~ 3800 MHz
<b>SCS</b>	30kHz
<b>Bandwidth</b>	n77: 20 / 40 / 50 / 60 / 80 / 90 / 100MHz n78: 20 / 30 / 40 / 50 / 60 / 70 / 80 / 90 / 100MHz
<b>Antenna Gain</b>	<p><b>&lt;Ant. 1&gt;</b> 5G NR n77: -2.3 dBi 5G NR n78: -2.3 dBi</p> <p><b>&lt;Ant. 6&gt;</b> 5G NR n77: 1.9 dBi 5G NR n78: 1.9 dBi</p> <p><b>&lt;Ant. 7&gt;</b> 5G NR n77: -1.2 dBi 5G NR n78: -1.2 dBi</p> <p><b>&lt;Ant. 8&gt;</b> 5G NR n77: 1.2 dBi 5G NR n78: 1.2 dBi</p>
<b>Type of Modulation</b>	CP-OFDM: QPSK / 16QAM / 64QAM / 256QAM DFT-s-OFDM: PI/2 BPSK / QPSK / 16QAM / 64QAM / 256QAM

**Remark:**

1. The maximum EIRP is calculated from max output power and max antenna gain, only the maximum EIRP of Antenna 6 for 5G NR n77/n78 is shown in the report.
2. The device supports n77(1T4R) SRS resources on Antenna 1/6/7/8, only the test data of worst Antenna 6 is showed in the report according to the maximum power.
3. 5G NR n78 support SA and NSA mode, n77 supports SA mode only. The whole testing has assessed SA mode for n77 by referring to the higher conducted power for conducted test items, and n78 additional test BW 30M/70MHz.
4. The device supports HPUE mode for 5G NR n77/n78.
5. The EN-DC mode combination could be referred to the product spec.

### 1.5 Modification of EUT

No modifications are made to the EUT during all test items.



### 1.6 Maximum EIRP and Emission Designator

5G NR n77 SA		PI/2 BPSK / QPSK		16QAM / 64QAM / 256QAM	
BW (MHz)	Frequency Range (MHz)	Maximum EIRP(W)	Emission Designator (99%OBW)	Maximum EIRP(W)	Emission Designator (99%OBW)
20	3710.01 ~ 3969.99	0.7482	18M2G7D	0.5808	18M2W7D
40	3720.00 ~ 3960.00	0.6808	37M8G7D	0.5260	37M8W7D
50	3725.01 ~ 3954.99	0.7362	47M5G7D	0.5636	47M5W7D
60	3730.02 ~ 3949.98	0.7063	57M8G7D	0.5768	57M8W7D
80	3740.01 ~ 3939.99	0.6918	77M3G7D	0.5309	77M6W7D
90	3745.02 ~ 3934.98	0.6546	87M5G7D	0.5070	87M5W7D
100	3750.00 ~ 3930.00	0.7691	97M6G7D	0.6109	97M3W7D

5G NR n78 SA		PI/2 BPSK / QPSK		16QAM / 64QAM / 256QAM	
BW (MHz)	Frequency Range (MHz)	Maximum EIRP(W)	Emission Designator (99%OBW)	Maximum EIRP(W)	Emission Designator (99%OBW)
20	3710.01 ~ 3789.99	0.7482	18M2G7D	0.5808	18M2W7D
30	3715.02 ~ 3784.98	0.7228	27M7G7D	0.5649	27M8W7D
40	3720.00 ~ 3780.00	0.6808	37M8G7D	0.5260	37M8W7D
50	3725.01 ~ 3774.99	0.7362	47M5G7D	0.5636	47M5W7D
60	3730.02 ~ 3769.98	0.7063	57M8G7D	0.5768	57M8W7D
70	3735.00 ~ 3765.00	0.7031	67M5G7D	0.5458	67M5W7D
80	3740.01 ~ 3759.99	0.6918	77M3G7D	0.5309	77M6W7D
90	3745.02 ~ 3754.98	0.6546	87M5G7D	0.5070	87M5W7D
100	3750.00 ~ 3750.00	0.7691	97M6G7D	0.6109	97M3W7D

Note:

- 5G NR Band n77 overlaps the entire frequency range of Band n78, and n77 power > n78 power, therefore the conducted test results of n77 provided in this report cover n78 except the bandwidth of 30M and 70M.
- All modulations have been tested, and only the worst test results of PSK & QAM are shown in the report.



### 1.7 Testing Location

Sporton International Inc. (ShenZhen) is accredited to ISO/IEC 17025:2017 by American Association for Laboratory Accreditation with Certificate Number 5145.01.

<b>Test Firm</b>	Sporton International Inc. (ShenZhen)		
<b>Test Site Location</b>	1/F, 2/F, Bldg 5, Shiling Industrial Zone, Xinwei Village, Xili, Nanshan, Shenzhen, 518055 People's Republic of China TEL: +86-755-86379589 FAX: +86-755-86379595		
<b>Test Site No.</b>	<b>Sporton Site No.</b>	<b>FCC Designation No.</b>	<b>FCC Test Firm Registration No.</b>
	TH01-SZ	CN1256	421272

<b>Test Firm</b>	Sporton International Inc. (ShenZhen)		
<b>Test Site Location</b>	101, 1st Floor, Block B, Building 1, No. 2, Tengfeng 4th Road, Fenghuang Community, Fuyong Street, Baoan District, Shenzhen City, Guangdong Province 518103 People's Republic of China TEL: +86-755-86066985		
<b>Test Site No.</b>	<b>Sporton Site No.</b>	<b>FCC Designation No.</b>	<b>FCC Test Firm Registration No.</b>
	03CH03-SZ	CN1256	421272

### 1.8 Test Software

Item	Site	Manufacture	Name	Version
1.	03CH03-SZ	AUDIX	E3	6.2009-8-24

### 1.9 Applicable Standards

According to the specifications of the manufacturer, the EUT must comply with the requirements of the following standards:

- ♦ 47 CFR Part 2, 27
- ♦ ANSI C63.26-2015
- ♦ FCC KDB 971168 D01 Power Meas License Digital Systems v03r01
- ♦ FCC KDB 412172 D01 Determining ERP and EIRP v01r01

**Remark:**

All test items were verified and recorded according to the standards and without any deviation during the test.



## 2 Test Configuration of Equipment Under Test

### 2.1 Test Mode

Antenna port conducted and radiated test items are performed according to KDB 971168 D01 Power Meas License Digital Systems v03r01 with maximum output power.

For radiated measurement, pre-scanned in three orthogonal panels, X, Y, Z. The worst cases (Y plane) were recorded in this report.

The device is investigated from 30MHz to 10 times of fundamental signal for radiated spurious emission test under different RB size/offset and modulations in exploratory test. Subsequently, only the worst case emissions are reported.

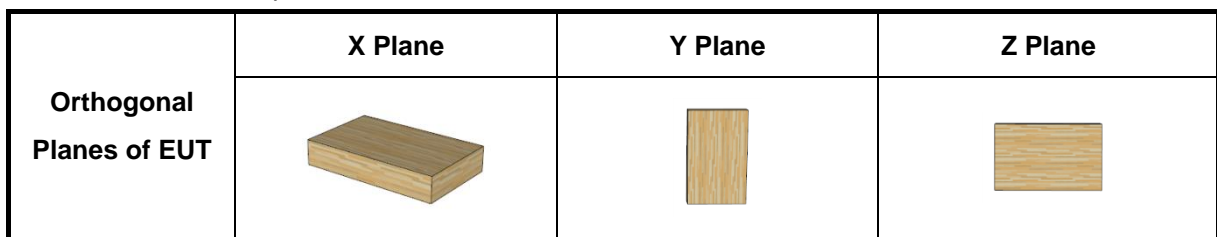

Test Items	5G NR	Bandwidth (MHz)										Modulation					RB #			Test Channel			
		10	20	30	40	50	60	70	80	90	100	PI/2 BPSK	QPSK	16QAM	64QAM	256 QAM	1	Partial	Full	L	M	H	
Max. Output Power	n77	-	v	-	v	v	v	-	v	v	v	v	v	v	v	v	v		v	v	v	v	
	n78	-		v				v				v	v	v	v	v	v		v	v	v	v	
Peak-to-Average Ratio	n77	-	v	-				-				v	v				v		v		v		
26dB and 99% Bandwidth	n77	-	v	-	v	v	v	-	v	v	v		v	v	v	v			v		v		
	n78	-		v				v					v	v	v	v			v		v		
Conducted Band Edge	n77	-	v	-			v	-			v	v	v				v		v	v		v	
	n78	-		v				v				v	v				v		v	v		v	
Conducted Spurious Emission	n77	-	v	-			v	-			v	v	v				v				v	v	v
	n78	-		v				v				v	v				v				v	v	v
Frequency Stability	n77	-	v	-				-					v						v		v		
E.I.R.P	n77	-	v	-	v	v	v	-	v	v	v	v	v	v	v	v	v		v	v	v	v	
	n78	-	v	v	v	v	v	v	v	v	v	v	v	v	v	v	v		v	v	v	v	
Radiated Spurious Emission	n77	Worst Case																				v	
	n78	Worst Case																				v	
Note	1. The mark "v" means that this configuration is chosen for testing 2. The mark "-" means that this bandwidth is not supported. 3. The device is investigated from 30MHz to 10 times of fundamental signal for radiated spurious emission test under different RB size/offset and modulations in exploratory test. Subsequently, only the worst case emissions are reported. 4. Frequency Stability : Normal Voltage = 3.88V; Low Voltage =3.6V; High Voltage =4.3V																						

## 2.2 Connection Diagram of Test System

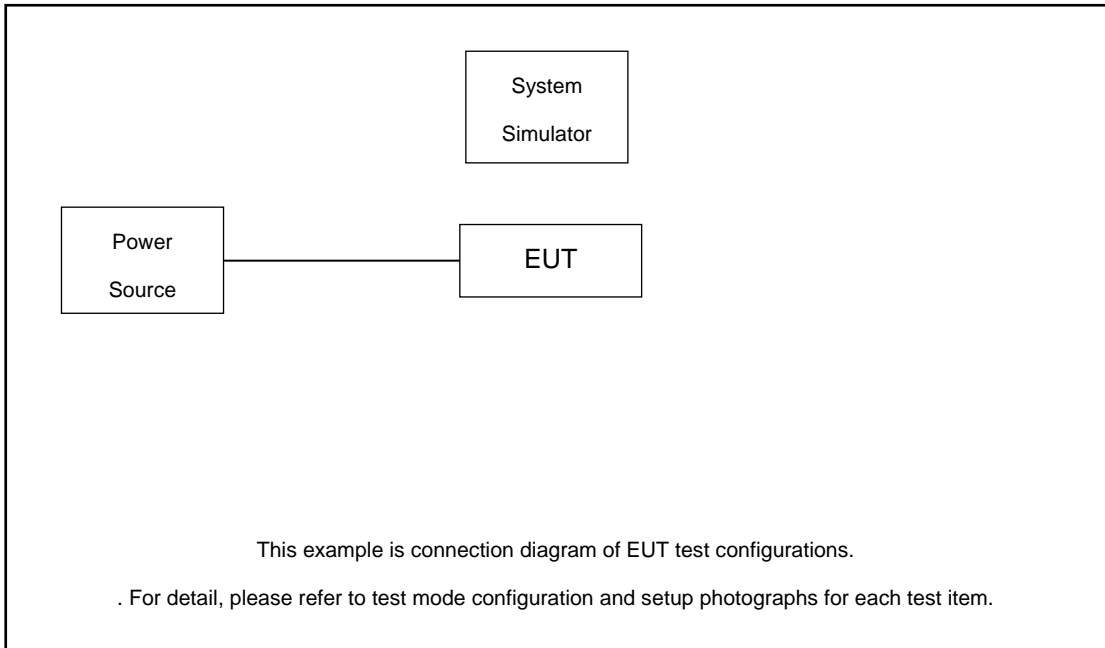

## 2.3 Support Unit used in test configuration and system

Item	Equipment	Trade Name	Model No.	FCC ID	Data Cable	Power Cord
1.	DC Power Supply	GW	GPS-3030D	N/A	N/A	Unshielded, 1.8 m
2.	LTE Base Station	Anritsu	MT8821C	N/A	N/A	Unshielded, 1.8 m
3.	NR Base Station	Anritsu	MT8000A	N/A	N/A	Unshielded, 1.8 m

## 2.4 Measurement Results Explanation Example

**For all conducted test items:**

The offset level is set in the spectrum analyzer to compensate the RF cable loss between EUT conducted output port and spectrum analyzer. With the offset compensation, the spectrum analyzer reading level is exactly the EUT RF output level.

The spectrum analyzer offset is derived from RF cable loss

$$\text{Offset} = \text{RF cable loss}$$

Following shows an offset computation example with cable loss 8.90dB

Example :

$$\begin{aligned} \text{Offset(dB)} &= \text{RF cable loss(dB)} \\ &= 8.90 \text{ (dB)} \end{aligned}$$



### 2.5 Frequency List of Low/Middle/High Channels

5G n77 Channel and Frequency List				
BW [MHz]	Channel/Frequency(MHz)	Lowest	Middle	Highest
100	Channel	650000	656000	662000
	Frequency	3750	3840	3930
90	Channel	649668	656000	662332
	Frequency	3745.02	3840	3934.98
80	Channel	649334	656000	662666
	Frequency	3740.01	3840	3939.99
60	Channel	648668	656000	663332
	Frequency	3730.02	3840	3949.98
50	Channel	648334	656000	663666
	Frequency	3725.01	3840	3954.99
40	Channel	648000	656000	664000
	Frequency	3720	3840	3960
20	Channel	647334	656000	664666
	Frequency	3710.01	3840	3969.99

5G n78 Channel and Frequency List				
BW [MHz]	Channel/Frequency(MHz)	Lowest	Middle	Highest
100	Channel	650000		
	Frequency	3750		
90	Channel	649668	650000	650332
	Frequency	3745.02	3750	3754.98
80	Channel	649334	650000	650666
	Frequency	3740.01	3750	3759.99
70	Channel	649000	650000	651000
	Frequency	3735	3750	3765
60	Channel	648668	650000	651332
	Frequency	3730.02	3750	3769.98
50	Channel	648334	650000	651666
	Frequency	3725.01	3750	3774.99
40	Channel	648000	650000	652000
	Frequency	3720	3750	3780
30	Channel	647668	650000	652332
	Frequency	3715.02	3750	3784.98
20	Channel	647334	650000	652666
	Frequency	3710.01	3750	3789.99

### 3 Conducted Test Items

#### 3.1 Measuring Instruments

See list of measuring instruments of this test report.

#### 3.2 Test Setup

##### 3.2.1 Conducted Output Power



##### 3.2.2 Peak-to-Average Ratio, Occupied Bandwidth, Conducted Band-Edge and Conducted Spurious Emission



##### 3.2.3 Frequency Stability

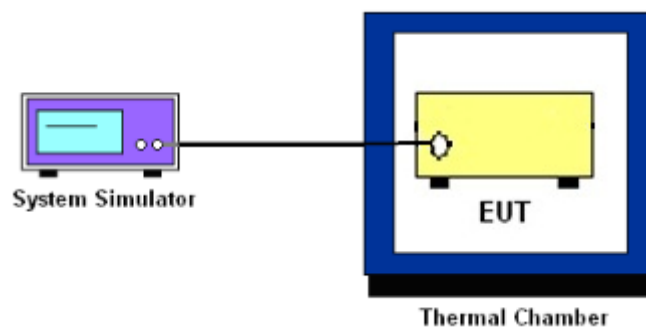

### 3.3 Test Result of Conducted Test

Please refer to Appendix A.



### 3.4 Conducted Output Power and EIRP

#### 3.4.1 Description of the Conducted Output Power Measurement and EIRP Measurement

A system simulator was used to establish communication with the EUT. Its parameters were set to force the EUT transmitting at maximum output power. The measured power in the radio frequency on the transmitter output terminals shall be reported.

The EIRP of mobile transmitters must not exceed 1 Watts for 5G NR n77, n78.

According to KDB 412172 D01 Power Approach,

$EIRP = P_T + G_T - L_C$ ,  $ERP = EIRP - 2.15$ , where

$P_T$  = transmitter output power in dBm

$G_T$  = gain of the transmitting antenna in dBi

$L_C$  = signal attenuation in the connecting cable between the transmitter and antenna in dB

#### 3.4.2 Test Procedures

1. The testing follows ANSI C63.26 Section 5.2
2. The transmitter output port was connected to the system simulator.
3. Set EUT at maximum power through the system simulator.
4. Select lowest, middle, and highest channels for each band and different modulation.
5. Measure and record the power level from the system simulator.



## **3.5 Peak-to-Average Ratio**

### **3.5.1 Description of the PAR Measurement**

Power Complementary Cumulative Distribution Function (CCDF) curves provide a means for characterizing the power peaks of a digitally modulated signal on a statistical basis. A CCDF curve depicts the probability of the peak signal amplitude exceeding the average power level. Most contemporary measurement instrumentation include the capability to produce CCDF curves for an input signal provided that the instrument's resolution bandwidth can be set wide enough to accommodate the entire input signal bandwidth. In measuring transmissions in this band using an average power technique, the peak-to-average ratio (PAR) of the transmission may not exceed 13 dB.

### **3.5.2 Test Procedures**

1. The testing follows ANSI C63.26 Section 5.2.3.4 (CCDF).
2. The EUT was connected to spectrum and system simulator via a power divider.
3. Set the CCDF (Complementary Cumulative Distribution Function) option in spectrum analyzer.
4. The highest RF powers were measured and recorded the maximum PAPR level associated with a probability of 0.1 %.
5. Record the deviation as Peak to Average Ratio.



### 3.6 Occupied Bandwidth

#### 3.6.1 Description of Occupied Bandwidth Measurement

The occupied bandwidth is the width of a frequency band such that, below the lower and above the upper frequency limits, the mean powers emitted are each equal to a specified percentage 0.5% of the total mean transmitted power.

The 26 dB emission bandwidth is defined as the frequency range between two points, one above and one below the carrier frequency, at which the spectral density of the emission is attenuated 26 dB below the maximum in-band spectral density of the modulated signal. Spectral density (power per unit bandwidth) is to be measured with a detector of resolution bandwidth equal to approximately 1.0% of the emission bandwidth.

#### 3.6.2 Test Procedures

1. The testing follows ANSI C63.26 Section 5.4
2. The EUT was connected to spectrum analyzer and system simulator via a power divider.
3. The spectrum analyzer center frequency is set to the nominal EUT channel center frequency. The span range for the spectrum analyzer shall be between two and five times the anticipated OBW.
4. The nominal resolution bandwidth (RBW) shall be in the range of 1 to 5 % of the anticipated OBW, and the VBW shall be at least 3 times the RBW.
5. Set the detection mode to peak, and the trace mode to max hold.
6. Determine the reference value: Set the EUT to transmit a modulated signal. Allow the trace to stabilize. Set the spectrum analyzer marker to the highest level of the displayed trace.  
(this is the reference value)
7. Determine the “-26 dB down amplitude” as equal to (Reference Value – X).
8. Place two markers, one at the lowest and the other at the highest frequency of the envelope of the spectral display such that each marker is at or slightly below the “-X dB down amplitude” determined in step 6. If a marker is below this “-X dB down amplitude” value it shall be placed as close as possible to this value. The OBW is the positive frequency difference between the two markers.
9. Use the 99 % power bandwidth function of the spectrum analyzer and report the measured bandwidth.



### 3.7 Conducted Band Edge

#### 3.7.1 Description of Conducted Band Edge Measurement

27.53(l)(2)

For mobile operations in the 3700-3980 MHz band, the conducted power of any emission outside the licensee's authorized bandwidth shall not exceed -13 dBm/MHz. Compliance with this paragraph is based on the use of measurement instrumentation employing a resolution bandwidth of 1 megahertz or greater. However, in the 1 megahertz bands immediately outside and adjacent to the licensee's frequency block, the minimum resolution bandwidth for the measurement shall be either one percent of the emission bandwidth of the fundamental emission of the transmitter or 350 kHz. In the bands between 1 and 5 MHz removed from the licensee's frequency block, the minimum resolution bandwidth for the measurement shall be 500 kHz.

#### 3.7.2 Test Procedures

1. The testing follows ANSI C63.26 section 5.7
2. The EUT was connected to spectrum analyzer and system simulator via a power divider.
3. The band edges of low and high channels for the highest RF powers were measured.
4. Set RBW  $\geq$  1% EBW in the 1MHz band immediately outside and adjacent to the band edge.
5. Beyond the 1 MHz band from the band edge, RBW=1MHz was used or a narrower RBW was used (generally limited to no less than 1% of the OBW) and the measured power was integrated over the full required measurement bandwidth.
6. Set spectrum analyzer with RMS detector.
7. The RF fundamental frequency should be excluded against the limit line in the operating frequency band.
8. Checked that all the results comply with the emission limit line.

Example:

$$\begin{aligned} & \text{The limit line is derived from } 43 + 10\log(P)\text{dB below the transmitter power } P(\text{Watts}) \\ & = P(\text{W}) - [43 + 10\log(P)] \text{ (dB)} \\ & = [30 + 10\log(P)] \text{ (dBm)} - [43 + 10\log(P)] \text{ (dB)} = -13\text{dBm.} \end{aligned}$$

9. When using the integration method, the starting frequency of the integration shall be centered at one-half of the RBW away from the band edge.





### 3.8 Conducted Spurious Emission

#### 3.8.1 Description of Conducted Spurious Emission Measurement

The power of any emission outside of the authorized operating frequency ranges must be lower than the transmitter power (P) by a factor of at least  $43 + 10 \log (P)$  dB.

It is measured by means of a calibrated spectrum analyzer and scanned from 30 MHz up to a frequency including its 10<sup>th</sup> harmonic.

#### 3.8.2 Test Procedures

1. The testing follows ANSI C63.26 section 5.7
2. The EUT was connected to spectrum analyzer and system simulator via a power divider.
3. The RF output of EUT was connected to the spectrum analyzer by RF cable and attenuator. The path loss was compensated to the results for each measurement.
4. The middle channel for the highest RF power within the transmitting frequency was measured.
5. The conducted spurious emission for the whole frequency range was taken.
6. Make the measurement with the spectrum analyzer's RBW = 1MHz, VBW = 3MHz.
7. Set spectrum analyzer with RMS detector.
8. Taking the record of maximum spurious emission.
9. The RF fundamental frequency should be excluded against the limit line in the operating frequency band.
10. The limit line is derived from  $43 + 10\log(P)$ dB below the transmitter power P(Watts)  
= P(W)- [43 + 10log(P)] (dB)  
= [30 + 10log(P)] (dBm) - [43 + 10log(P)] (dB)  
= -13dBm.



## 3.9 Frequency Stability

### 3.9.1 Description of Frequency Stability Measurement

The frequency stability shall be measured by variation of ambient temperature and variation of primary supply voltage to ensure that the fundamental emission stays within the authorized frequency block. The frequency stability of the transmitter shall be maintained within  $\pm 0.00025\%$  ( $\pm 2.5\text{ppm}$ ) of the center frequency.

### 3.9.2 Test Procedures for Temperature Variation

1. The testing follows ANSI C63.26 section 5.6.4
2. The EUT was set up in the thermal chamber and connected with the system simulator.
3. With power OFF, the temperature was decreased to  $-30^{\circ}\text{C}$  and the EUT was stabilized before testing. Power was applied and the maximum change in frequency was recorded within one minute.
4. With power OFF, the temperature was raised in  $10^{\circ}\text{C}$  step up to  $50^{\circ}\text{C}$ . The EUT was stabilized at each step for at least half an hour. Power was applied and the maximum frequency change was recorded within one minute.

### 3.9.3 Test Procedures for Voltage Variation

1. The testing follows ANSI C63.26 section 5.6.5
2. The EUT was placed in a temperature chamber at  $20\pm 5^{\circ}\text{C}$  and connected with the system simulator.
3. The power supply voltage to the EUT was varied from 85% to 115% of the nominal value for other than hand carried battery equipment.
4. For hand carried, battery powered equipment, reduce the primary ac or dc supply voltage to the battery operating end point, which shall be specified by the manufacturer.
5. The variation in frequency was measured for the worst case.

## 4 Radiated Test Items

### 4.1 Measuring Instruments

See list of measuring instruments of this test report.

### 4.2 Test Setup

#### 4.2.1 For radiated test below 30MHz

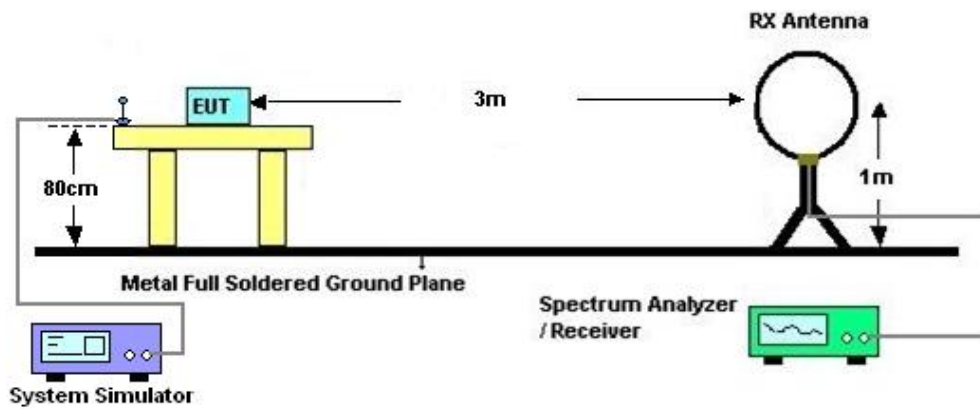

#### 4.2.2 For radiated test from 30MHz to 1GHz

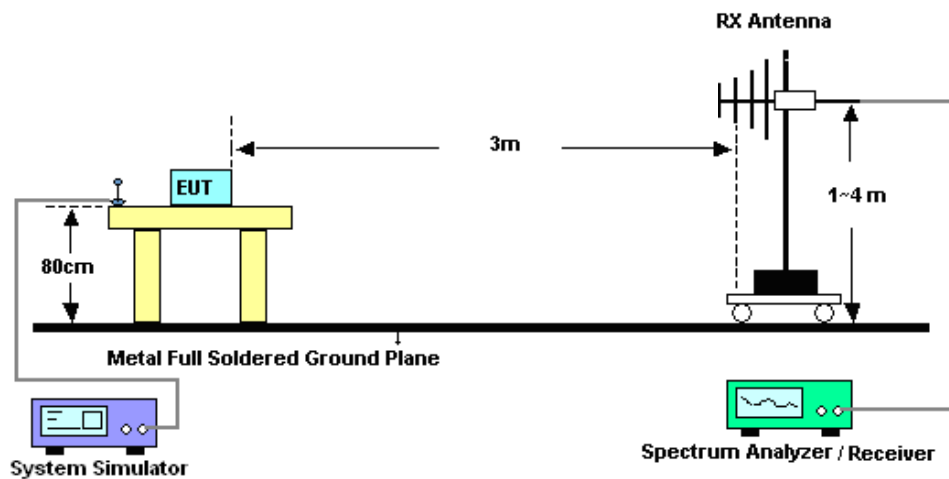

#### 4.2.3 For radiated test above 1GHz

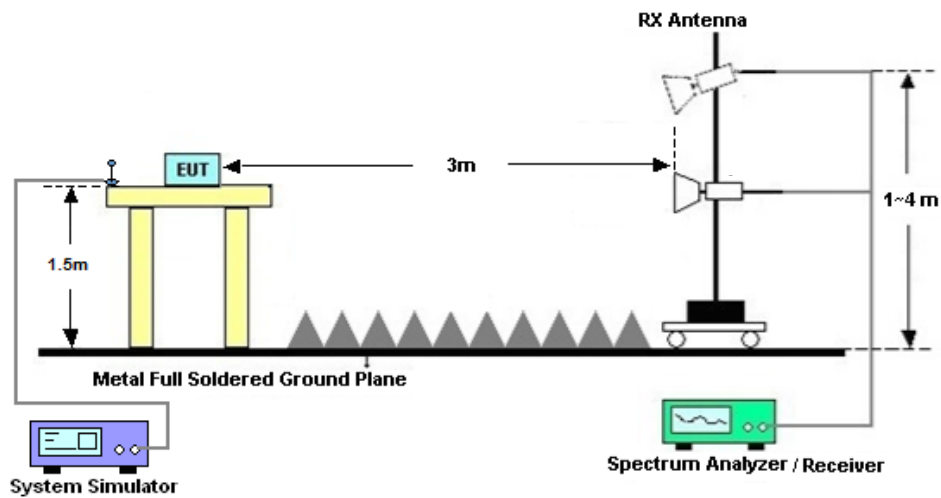

### 4.3 Test Result of Radiated Test

The low frequency, which started from 9 kHz to 30MHz, was pre-scanned and the result which was 20dB lower than the limit line was not reported.

Please refer to Appendix B.



## 4.4 Radiated Spurious Emission

### 4.4.1 Description of Radiated Spurious Emission

The radiated spurious emission was measured by substitution method according to ANSI C63.26. The power of any emission outside of the authorized operating frequency ranges must be attenuated below the transmitter power (P) by a factor of at least  $43 + 10 \log(P)$  dB. The spectrum is scanned from 30 MHz up to a frequency including its 10th harmonic.

### 4.4.2 Test Procedures

1. The testing follows ANSI C63.26 Section 5.5
2. The EUT was placed on a turntable with 0.8 meter height for frequency below 1GHz and 1.5 meter height for frequency above 1GHz respectively above ground.
3. The EUT was set 3 meters from the receiving antenna mounted on the antenna tower.
4. The table was rotated 360 degrees to determine the position of the highest spurious emission.
5. The height of the receiving antenna is varied between 1m to 4m to search the maximum spurious emission for both horizontal and vertical polarizations.
6. During the measurement, the system simulator parameters were set to force the EUT transmitting at maximum output power.
7. Make the measurement with the spectrum analyzer's RBW = 1MHz, VBW = 3MHz, taking the record of maximum spurious emission.
8. A horn antenna was substituted in place of the EUT and was driven by a signal generator.
9. Tune the output power of signal generator to the same emission level with EUT maximum spurious emission.
10.  $EIRP \text{ (dBm)} = S.G. \text{ Power} - Tx \text{ Cable Loss} + Tx \text{ Antenna Gain}$
11.  $ERP \text{ (dBm)} = EIRP - 2.15$
12. The RF fundamental frequency should be excluded against the limit line in the operating frequency band.

The limit line is derived from  $43 + 10\log(P)$ dB below the transmitter power P(Watts)  
=  $P(W) - [43 + 10\log(P)] \text{ (dB)}$   
=  $[30 + 10\log(P)] \text{ (dBm)} - [43 + 10\log(P)] \text{ (dB)}$   
= -13dBm.



## 5 List of Measuring Equipment

Instrument	Manufacturer	Model No.	Serial No.	Characteristics	Calibration Date	Test Date	Due Date	Remark
Spectrum Analyzer	R&S	FSV40	101078	10Hz~40GHz	Apr. 06, 2023	Aug. 14, 2023~ Aug. 16, 2023	Apr. 05, 2024	Conducted (TH01-SZ)
DC Power Supply	TTI	PL330P	290070	Max 32V , 3A	Oct. 17, 2022	Aug. 14, 2023~ Aug. 16, 2023	Oct. 16, 2023	Conducted (TH01-SZ)
Power Divider	TOJOIN	PS-2SM-04 265	60.06.020.007 7	0.4GHz~26.5GHz	Dec. 25, 2022	Aug. 14, 2023~ Aug. 16, 2023	Dec. 24, 2023	Conducted (TH01-SZ)
Thermal Chamber	Ten Billion Hongzhangroup	LP-150U	H2014081803	-40~+150°C	Jul. 05, 2023	Aug. 14, 2023~ Aug. 16, 2023	Jul. 04, 2024	Conducted (TH01-SZ)
EMI Test Receiver&SA	KEYSIGHT	N9038A	MY54450083	20Hz~8.4GHz	Apr. 04, 2023	Aug. 20, 2023	Apr. 03, 2024	Radiation (03CH03-SZ)
EXA Spectrum Analyzer	KEYSIGHT	N9010A	MY55150246	10Hz~44GHz;	Apr. 04, 2023	Aug. 20, 2023	Apr. 03, 2024	Radiation (03CH03-SZ)
Loop Antenna	R&S	HFH2-Z2	100354	9kHz~30MHz	Jun. 28, 2022	Aug. 20, 2023	Jun. 27, 2024	Radiation (03CH03-SZ)
Bilog Antenna	TeseQ	CBL6112D	35408	30MHz-2GHz	Aug. 20, 2023	Aug. 20, 2023	Aug. 19, 2025	Radiation (03CH03-SZ)
Double Ridge Horn Antenna	SCHWARZBECK	BBHA9120D	9120D-1355	1GHz~18GHz	Apr. 08, 2023	Aug. 20, 2023	Apr. 07, 2024	Radiation (03CH03-SZ)
SHF-EHF Horn	com-power	AH-840	101071	18Ghz-40GHz	Apr. 08, 2023	Aug. 20, 2023	Apr. 07, 2024	Radiation (03CH03-SZ)
Amplifier	Burgeon	BPA-530	102211	0.01Hz ~3000MHz	Oct. 19, 2022	Aug. 20, 2023	Oct. 18, 2023	Radiation (03CH03-SZ)
HF Amplifier	MITEQ	TTA1840-35 -HG	1871923	18GHz~40GHz	Jul. 07, 2023	Aug. 20, 2023	Jul.06, 2024	Radiation (03CH03-SZ)
Amplifier	Agilent Technologies	83017A	MY39501302	500MHz~26.5GHz	Dec. 26, 2022	Aug. 20, 2023	Dec. 25, 2023	Radiation (03CH03-SZ)
AC Power Source	Chroma	61601	616010002729	N/A	Nov. 10, 2022	Aug. 20, 2023	Nov. 09, 2023	Radiation (03CH03-SZ)
Turn Table	EM	EM1000	N/A	0~360 degree	NCR	Aug. 20, 2023	NCR	Radiation (03CH03-SZ)
Antenna Mast	EM	EM1000	N/A	1 m~4 m	NCR	Aug. 20, 2023	NCR	Radiation (03CH03-SZ)

NCR: No Calibration Required



## 6 Measurement Uncertainty

The measurement uncertainties shown below were calculated in accordance with the requirements of ANSI 63.26-2015. All the measurement uncertainty value were shown with a coverage K=2 to indicate 95% level of confidence. The measurement data show herein meets or exceeds the CISPR measurement uncertainty values specified in CISPR 16-4-2 and can be compared directly to specified limit to determine compliance.

### Uncertainty of Conducted Measurement

Test Item	Uncertainty
Conducted Power	±1.34 dB
Conducted Emissions	±1.34 dB
Occupied Channel Bandwidth	±0.13 %

### Uncertainty of Radiated Emission Measurement (30 MHz ~ 1000 MHz)

Measuring Uncertainty for a Level of Confidence of 95% (U = 2Uc(y))	3dB
---	-----

### Uncertainty of Radiated Emission Measurement (1 GHz ~ 18 GHz)

Measuring Uncertainty for a Level of Confidence of 95% (U = 2Uc(y))	3.6dB
---	-------

### Uncertainty of Radiated Emission Measurement (18 GHz ~ 40 GHz)

Measuring Uncertainty for a Level of Confidence of 95% (U = 2Uc(y))	3.8dB
---	-------

----- THE END -----



## Appendix A. Test Results of Conducted Test

Test Engineer :	Jung Kuo	Temperature :	22~23°C
		Relative Humidity :	40~42%



# FR1 N77(ANT6)

## Transmitter Conducted Output Power And EIRP, (G<sub>T</sub> - L<sub>C</sub>)=1.9dB

NR Band	SCS (kHz)	Bandwidth (MHz)	Arfcn	Freq (MHz)	Modulation	RB	Conducted Power(dBm)	EIRP (dBm)	EIRP (W)
77	30	20	647334	3710.01	DFT-s-OFDM QPSK	1@1	26.53	28.43	0.6966
77	30	20	647334	3710.01	DFT-s-OFDM 16 QAM	1@1	25.74	27.64	0.5808
77	30	20	656000	3840.0	DFT-s-OFDM QPSK	1@1	26.84	28.74	0.7482
77	30	20	656000	3840.0	DFT-s-OFDM 16 QAM	1@1	25.73	27.63	0.5794
77	30	20	664666	3969.99	DFT-s-OFDM QPSK	1@1	26.53	28.43	0.6966
77	30	20	664666	3969.99	DFT-s-OFDM 16 QAM	1@1	25.45	27.35	0.5433
77	30	40	648000	3720.0	DFT-s-OFDM QPSK	1@1	26.28	28.18	0.6577
77	30	40	648000	3720.0	DFT-s-OFDM 16 QAM	1@1	25.17	27.07	0.5093
77	30	40	656000	3840.0	DFT-s-OFDM QPSK	1@1	26.43	28.33	0.6808
77	30	40	656000	3840.0	DFT-s-OFDM 16 QAM	1@1	25.31	27.21	0.5260
77	30	40	664000	3960.0	DFT-s-OFDM QPSK	1@1	26.21	28.11	0.6471
77	30	40	664000	3960.0	DFT-s-OFDM 16 QAM	1@1	25.15	27.05	0.5070
77	30	50	648334	3725.01	DFT-s-OFDM QPSK	1@1	26.67	28.57	0.7194
77	30	50	648334	3725.01	DFT-s-OFDM 16 QAM	1@1	25.52	27.42	0.5521
77	30	50	656000	3840.0	DFT-s-OFDM QPSK	1@1	26.77	28.67	0.7362
77	30	50	656000	3840.0	DFT-s-OFDM 16 QAM	1@1	25.61	27.51	0.5636
77	30	50	663666	3954.99	DFT-s-OFDM QPSK	1@1	26.51	28.41	0.6934
77	30	50	663666	3954.99	DFT-s-OFDM 16 QAM	1@1	25.38	27.28	0.5346
77	30	60	648668	3730.02	DFT-s-OFDM QPSK	1@1	26.42	28.32	0.6792
77	30	60	648668	3730.02	DFT-s-OFDM 16 QAM	1@1	25.34	27.24	0.5297
77	30	60	656000	3840.0	DFT-s-OFDM QPSK	1@1	26.59	28.49	0.7063
77	30	60	656000	3840.0	DFT-s-OFDM 16 QAM	1@1	25.71	27.61	0.5768

77	30	60	663332	3949.98	DFT-s-OFDM QPSK	1@1	26.43	28.33	0.6808
77	30	60	663332	3949.98	DFT-s-OFDM 16 QAM	1@1	25.26	27.16	0.5200
77	30	80	649334	3740.01	DFT-s-OFDM QPSK	1@1	26.32	28.22	0.6637
77	30	80	649334	3740.01	DFT-s-OFDM 16 QAM	1@1	25.17	27.07	0.5093
77	30	80	656000	3840.0	DFT-s-OFDM QPSK	1@1	26.5	28.4	0.6918
77	30	80	656000	3840.0	DFT-s-OFDM 16 QAM	1@1	25.35	27.25	0.5309
77	30	80	662666	3939.99	DFT-s-OFDM QPSK	1@1	26.39	28.29	0.6745
77	30	80	662666	3939.99	DFT-s-OFDM 16 QAM	1@1	25.29	27.19	0.5236
77	30	90	649668	3745.02	DFT-s-OFDM QPSK	1@1	26.2	28.1	0.6457
77	30	90	649668	3745.02	DFT-s-OFDM 16 QAM	1@1	25.09	26.99	0.5000
77	30	90	656000	3840.0	DFT-s-OFDM QPSK	1@1	26.26	28.16	0.6546
77	30	90	656000	3840.0	DFT-s-OFDM 16 QAM	1@1	25.12	27.02	0.5035
77	30	90	662332	3934.98	DFT-s-OFDM QPSK	1@1	26.26	28.16	0.6546
77	30	90	662332	3934.98	DFT-s-OFDM 16 QAM	1@1	25.15	27.05	0.5070
77	30	100	650000	3750.0	DFT-s-OFDM PI/2 BPSK	135@67	26.86	28.76	0.7516
77	30	100	650000	3750.0	DFT-s-OFDM PI/2 BPSK	1@1	26.04	27.94	0.6223
77	30	100	650000	3750.0	DFT-s-OFDM PI/2 BPSK	1@271	26	27.9	0.6166
77	30	100	650000	3750.0	DFT-s-OFDM QPSK	135@67	26.85	28.75	0.7499
77	30	100	650000	3750.0	DFT-s-OFDM QPSK	1@1	26.08	27.98	0.6281
77	30	100	650000	3750.0	DFT-s-OFDM QPSK	1@271	26	27.9	0.6166
77	30	100	650000	3750.0	DFT-s-OFDM 16 QAM	135@67	25.85	27.75	0.5957
77	30	100	650000	3750.0	DFT-s-OFDM 16 QAM	1@1	24.96	26.86	0.4853
77	30	100	650000	3750.0	DFT-s-OFDM 16 QAM	1@271	24.94	26.84	0.4831
77	30	100	650000	3750.0	DFT-s-OFDM 64 QAM	135@67	24.31	26.21	0.4178
77	30	100	650000	3750.0	DFT-s-OFDM 64 QAM	1@1	23.57	25.47	0.3524
77	30	100	650000	3750.0	DFT-s-OFDM 64 QAM	1@271	23.54	25.44	0.3499
77	30	100	650000	3750.0	DFT-s-OFDM 256 QAM	135@67	22.25	24.15	0.2600

77	30	100	650000	3750.0	DFT-s-OFDM 256 QAM	1@1	21.27	23.17	0.2075
77	30	100	650000	3750.0	DFT-s-OFDM 256 QAM	1@271	21.21	23.11	0.2046
77	30	100	650000	3750.0	CP-OFDM QPSK	137@68	25.31	27.21	0.5260
77	30	100	650000	3750.0	CP-OFDM QPSK	1@1	24.61	26.51	0.4477
77	30	100	650000	3750.0	CP-OFDM QPSK	1@271	24.53	26.43	0.4395
77	30	100	656000	3840.0	DFT-s-OFDM PI/2 BPSK	135@67	26.94	28.84	0.7656
77	30	100	656000	3840.0	DFT-s-OFDM PI/2 BPSK	1@1	26.13	28.03	0.6353
77	30	100	656000	3840.0	DFT-s-OFDM PI/2 BPSK	1@271	25.79	27.69	0.5875
77	30	100	656000	3840.0	DFT-s-OFDM QPSK	135@67	26.96	28.86	0.7691
77	30	100	656000	3840.0	DFT-s-OFDM QPSK	1@1	26.14	28.04	0.6368
77	30	100	656000	3840.0	DFT-s-OFDM QPSK	1@271	25.82	27.72	0.5916
77	30	100	656000	3840.0	DFT-s-OFDM 16 QAM	135@67	25.96	27.86	0.6109
77	30	100	656000	3840.0	DFT-s-OFDM 16 QAM	1@1	24.98	26.88	0.4875
77	30	100	656000	3840.0	DFT-s-OFDM 16 QAM	1@271	24.7	26.6	0.4571
77	30	100	656000	3840.0	DFT-s-OFDM 64 QAM	135@67	24.4	26.3	0.4266
77	30	100	656000	3840.0	DFT-s-OFDM 64 QAM	1@1	23.63	25.53	0.3573
77	30	100	656000	3840.0	DFT-s-OFDM 64 QAM	1@271	23.29	25.19	0.3304
77	30	100	656000	3840.0	DFT-s-OFDM 256 QAM	135@67	22.38	24.28	0.2679
77	30	100	656000	3840.0	DFT-s-OFDM 256 QAM	1@1	21.34	23.24	0.2109
77	30	100	656000	3840.0	DFT-s-OFDM 256 QAM	1@271	21.02	22.92	0.1959
77	30	100	656000	3840.0	CP-OFDM QPSK	137@68	25.45	27.35	0.5433
77	30	100	656000	3840.0	CP-OFDM QPSK	1@1	24.6	26.5	0.4467
77	30	100	656000	3840.0	CP-OFDM QPSK	1@271	24.32	26.22	0.4188
77	30	100	662000	3930.0	DFT-s-OFDM PI/2 BPSK	135@67	26.64	28.54	0.7145
77	30	100	662000	3930.0	DFT-s-OFDM PI/2 BPSK	1@1	26.17	28.07	0.6412
77	30	100	662000	3930.0	DFT-s-OFDM PI/2 BPSK	1@271	25.76	27.66	0.5834
77	30	100	662000	3930.0	DFT-s-OFDM QPSK	135@67	26.69	28.59	0.7228

77	30	100	662000	3930.0	DFT-s-OFDM QPSK	1@1	26.2	28.1	0.6457
77	30	100	662000	3930.0	DFT-s-OFDM QPSK	1@271	25.81	27.71	0.5902
77	30	100	662000	3930.0	DFT-s-OFDM 16 QAM	135@67	25.71	27.61	0.5768
77	30	100	662000	3930.0	DFT-s-OFDM 16 QAM	1@1	25.09	26.99	0.5000
77	30	100	662000	3930.0	DFT-s-OFDM 16 QAM	1@271	24.66	26.56	0.4529
77	30	100	662000	3930.0	DFT-s-OFDM 64 QAM	135@67	24.17	26.07	0.4046
77	30	100	662000	3930.0	DFT-s-OFDM 64 QAM	1@1	23.72	25.62	0.3648
77	30	100	662000	3930.0	DFT-s-OFDM 64 QAM	1@271	23.29	25.19	0.3304
77	30	100	662000	3930.0	DFT-s-OFDM 256 QAM	135@67	22.08	23.98	0.2500
77	30	100	662000	3930.0	DFT-s-OFDM 256 QAM	1@1	21.4	23.3	0.2138
77	30	100	662000	3930.0	DFT-s-OFDM 256 QAM	1@271	20.98	22.88	0.1941
77	30	100	662000	3930.0	CP-OFDM QPSK	137@68	25.16	27.06	0.5082
77	30	100	662000	3930.0	CP-OFDM QPSK	1@1	24.66	26.56	0.4529
77	30	100	662000	3930.0	CP-OFDM QPSK	1@271	24.3	26.2	0.4169

## Frequency Stability

NR Band	SCS (kHz)	Bandwidth (MHz)	Arfcn	Freq (MHz)	Modulation	RB	Deviation (ppm)	Verdict	Environment
77	30	20	656000	3840.0	DFT-s-OFDM QPSK	50@0	0.0050	PASS	NV
77	30	20	656000	3840.0	DFT-s-OFDM QPSK	50@0	0.0061	PASS	LV
77	30	20	656000	3840.0	DFT-s-OFDM QPSK	50@0	0.0060	PASS	HV
77	30	20	656000	3840.0	DFT-s-OFDM QPSK	50@0	0.0030	PASS	-30°C
77	30	20	656000	3840.0	DFT-s-OFDM QPSK	50@0	0.0043	PASS	-20°C
77	30	20	656000	3840.0	DFT-s-OFDM QPSK	50@0	0.0041	PASS	-10°C
77	30	20	656000	3840.0	DFT-s-OFDM QPSK	50@0	0.0037	PASS	0°C
77	30	20	656000	3840.0	DFT-s-OFDM QPSK	50@0	0.0039	PASS	10°C
77	30	20	656000	3840.0	DFT-s-OFDM QPSK	50@0	0.0050	PASS	20°C
77	30	20	656000	3840.0	DFT-s-OFDM QPSK	50@0	0.0024	PASS	30°C
77	30	20	656000	3840.0	DFT-s-OFDM QPSK	50@0	0.0052	PASS	40°C
77	30	20	656000	3840.0	DFT-s-OFDM QPSK	50@0	0.0031	PASS	50°C

## Peak to Average Ratio

NR Band	SCS (kHz)	Bandwidth (MHz)	Arfcn	Freq (MHz)	Modulation	RB	Result (dB)	Limit (dB)	Verdict
77	30	20	656000	3840.0	DFT-s-OFDM PI/2 BPSK	50@0	6.64	13	PASS
77	30	20	656000	3840.0	DFT-s-OFDM PI/2 BPSK	1@0	6.99	13	PASS
77	30	20	656000	3840.0	DFT-s-OFDM QPSK	50@0	7.83	13	PASS
77	30	20	656000	3840.0	DFT-s-OFDM QPSK	1@0	8.53	13	PASS

N77(20M)\_DFT-s-OFDM\_PI\_2-BPSK\_Outer\_Full\_Mid\_CH

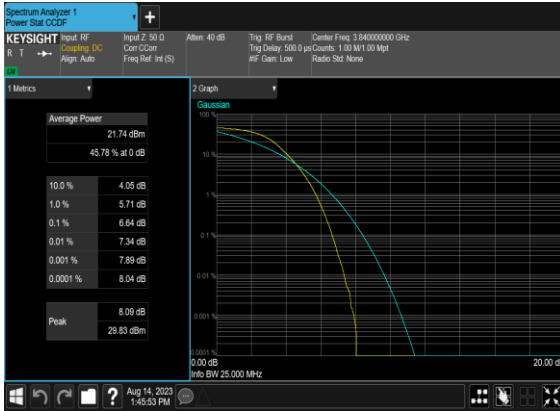

N77(20M)\_DFT-s-OFDM\_PI\_2-BPSK\_Edge\_1RB\_Left\_Mid\_CH

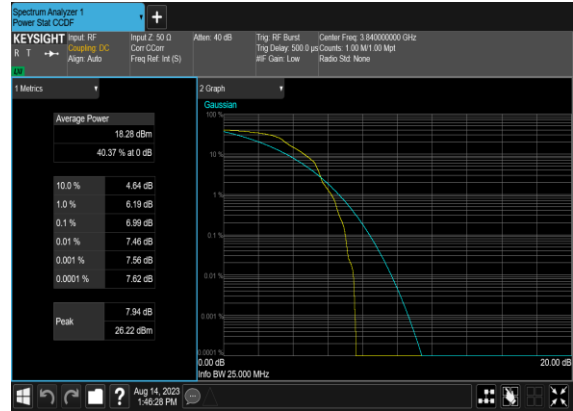

N77(20M)\_DFT-s-OFDM\_QPSK\_Outer\_Full\_Mid\_CH



N77(20M)\_DFT-s-OFDM\_QPSK\_Edge\_1RB\_Left\_Mid\_CH



## Occupied Bandwidth

NR Band	SCS (kHz)	Bandwidth (MHz)	Arfcn	Freq (MHz)	Modulation	RB	OBW (MHz)	26dB BW (MHz)
77	30	20	656000	3840.0	CP-OFDM QPSK	51@0	18.2	19.0
77	30	20	656000	3840.0	CP-OFDM 16 QAM	51@0	18.184	19.03
77	30	20	656000	3840.0	CP-OFDM 64 QAM	51@0	18.145	18.84
77	30	20	656000	3840.0	CP-OFDM 256 QAM	51@0	18.175	18.97
77	30	40	656000	3840.0	CP-OFDM QPSK	106@0	37.827	39.08
77	30	40	656000	3840.0	CP-OFDM 16 QAM	106@0	37.77	39.13
77	30	40	656000	3840.0	CP-OFDM 64 QAM	106@0	37.817	39.32
77	30	40	656000	3840.0	CP-OFDM 256 QAM	106@0	37.802	39.1
77	30	50	656000	3840.0	CP-OFDM QPSK	133@0	47.49	49.02
77	30	50	656000	3840.0	CP-OFDM 16 QAM	133@0	47.395	48.99
77	30	50	656000	3840.0	CP-OFDM 64 QAM	133@0	47.462	49.13
77	30	50	656000	3840.0	CP-OFDM 256 QAM	133@0	47.335	49.06
77	30	60	656000	3840.0	CP-OFDM QPSK	162@0	57.822	59.65
77	30	60	656000	3840.0	CP-OFDM 16 QAM	162@0	57.793	59.7
77	30	60	656000	3840.0	CP-OFDM 64 QAM	162@0	57.736	59.65
77	30	60	656000	3840.0	CP-OFDM 256 QAM	162@0	57.72	59.72
77	30	80	656000	3840.0	CP-OFDM QPSK	217@0	77.349	79.92
77	30	80	656000	3840.0	CP-OFDM 16 QAM	217@0	77.499	79.95
77	30	80	656000	3840.0	CP-OFDM 64 QAM	217@0	77.265	80.03
77	30	80	656000	3840.0	CP-OFDM 256 QAM	217@0	77.628	80.0
77	30	90	656000	3840.0	CP-OFDM QPSK	245@0	87.487	90.25
77	30	90	656000	3840.0	CP-OFDM 16 QAM	245@0	87.535	90.16
77	30	90	656000	3840.0	CP-OFDM 64 QAM	245@0	87.287	90.27
77	30	90	656000	3840.0	CP-OFDM 256 QAM	245@0	87.418	90.17
77	30	100	656000	3840.0	CP-OFDM QPSK	273@0	97.578	100.4



77	30	100	656000	3840.0	CP-OFDM 16 QAM	273@0	97.261	100.5
77	30	100	656000	3840.0	CP-OFDM 64 QAM	273@0	97.281	100.4
77	30	100	656000	3840.0	CP-OFDM 256 QAM	273@0	96.972	100.5

### N77(20M)\_CP-OFDM\_QPSK\_Outer\_Full\_Mid\_CH

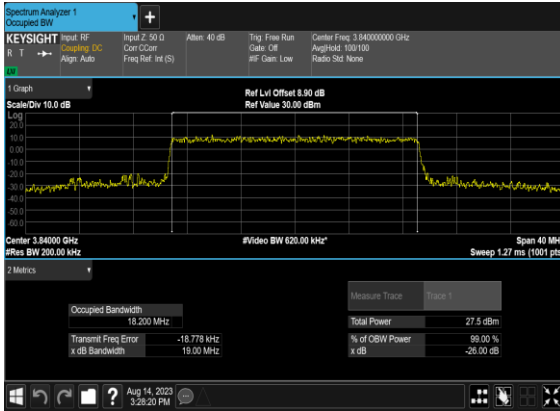

### N77(20M)\_CP-OFDM\_16 QAM\_Outer\_Full\_Mid\_CH

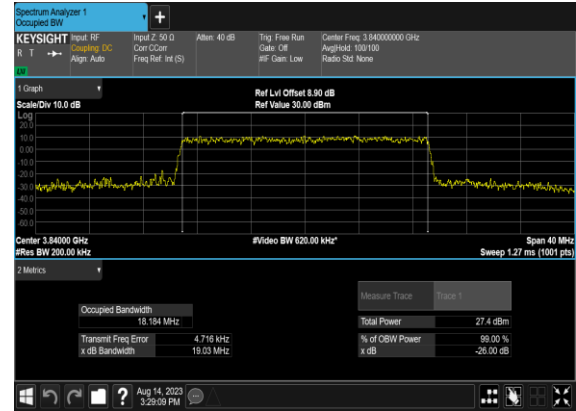

### N77(20M)\_CP-OFDM\_64 QAM\_Outer\_Full\_Mid\_CH

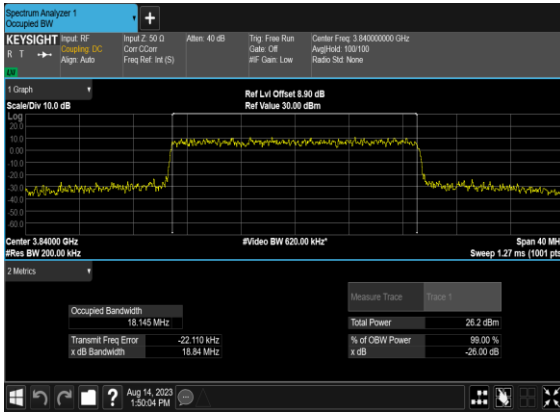

### N77(20M)\_CP-OFDM\_256 QAM\_Outer\_Full\_Mid\_CH

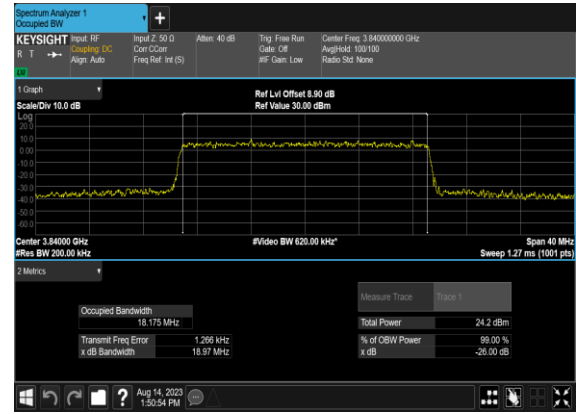

### N77(40M)\_CP-OFDM\_QPSK\_Outer\_Full\_Mid\_CH

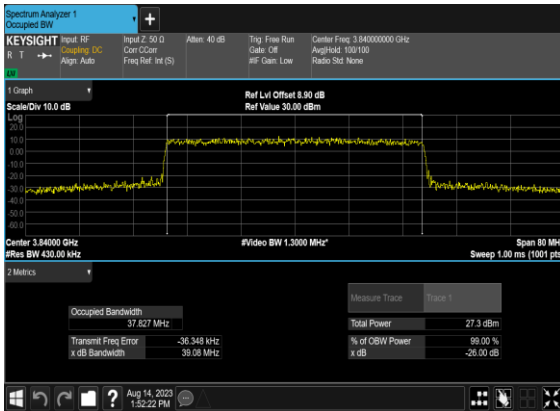

### N77(40M)\_CP-OFDM\_16 QAM\_Outer\_Full\_Mid\_CH

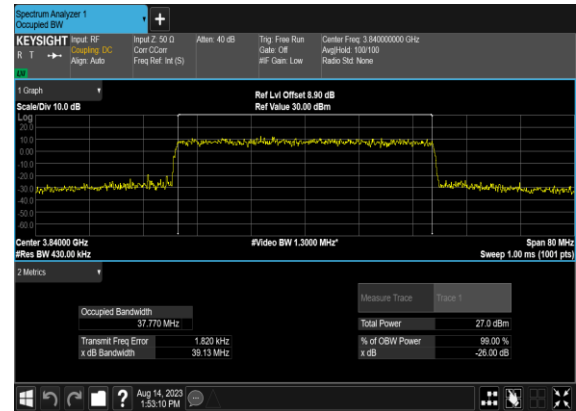

### N77(40M)\_CP-OFDM\_64 QAM\_Outer\_Full\_Mid\_CH

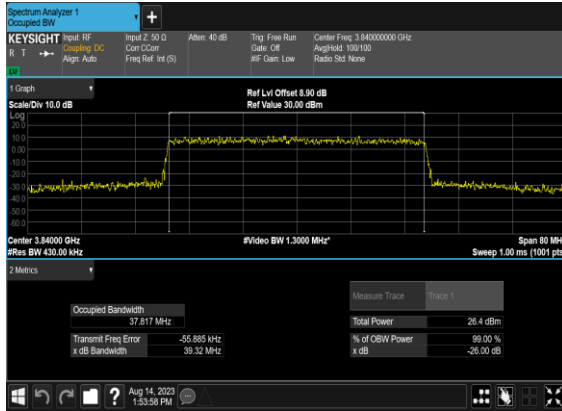

### N77(40M)\_CP-OFDM\_256 QAM\_Outer\_Full\_Mid\_CH

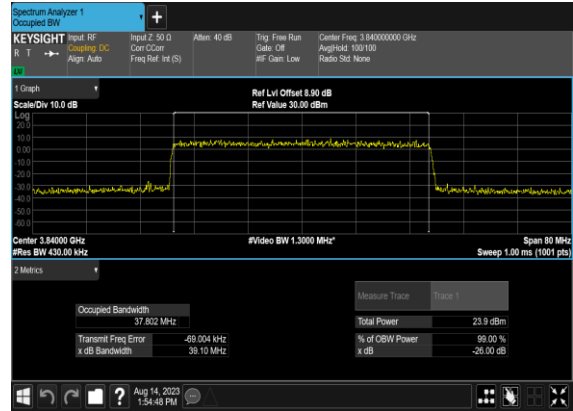

### N77(50M)\_CP- OFDM\_QPSK\_Outer\_Full\_Mid\_CH



### N77(50M)\_CP-OFDM\_16 QAM\_Outer\_Full\_Mid\_CH



### N77(50M)\_CP-OFDM\_64 QAM\_Outer\_Full\_Mid\_CH

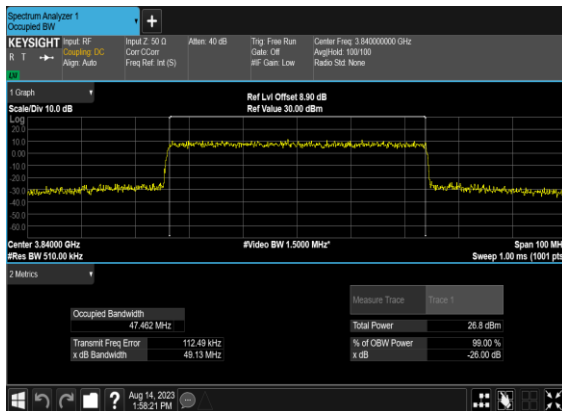

### N77(50M)\_CP-OFDM\_256 QAM\_Outer\_Full\_Mid\_CH

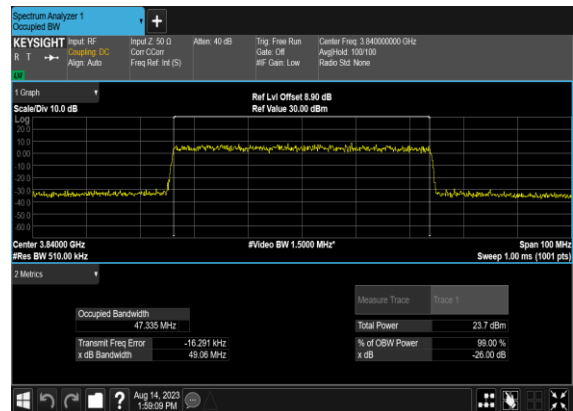

### N77(60M)\_CP-OFDM\_QPSK\_Outer\_Full\_Mid\_CH

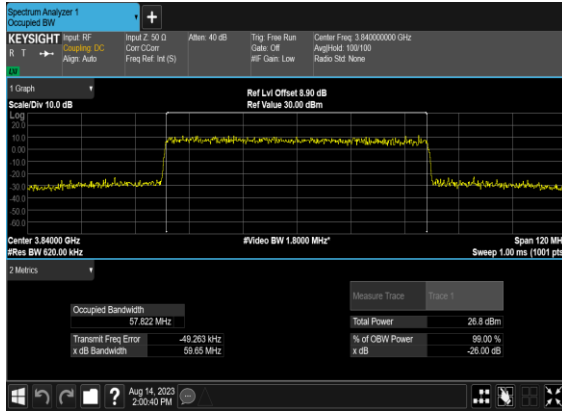

### N77(60M)\_CP-OFDM\_16QAM\_Outer\_Full\_Mid\_CH

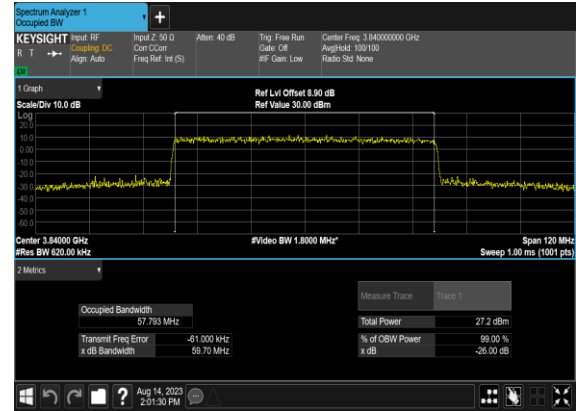

### N77(60M)\_CP-OFDM\_64QAM\_Outer\_Full\_Mid\_CH



### N77(60M)\_CP-OFDM\_256QAM\_Outer\_Full\_Mid\_CH

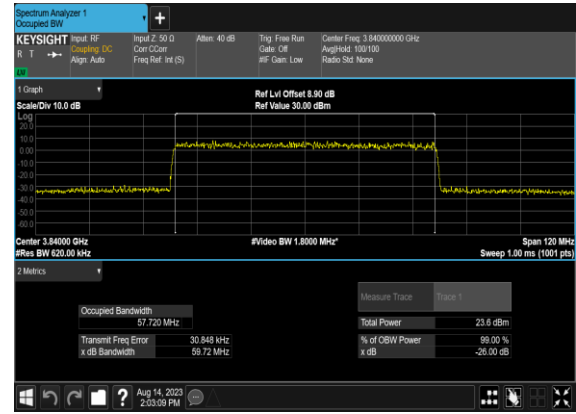

### N77(80M)\_CP-OFDM\_QPSK\_Outer\_Full\_Mid\_CH

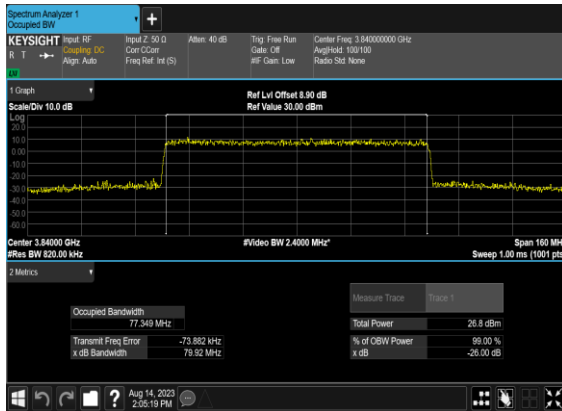

### N77(80M)\_CP-OFDM\_16QAM\_Outer\_Full\_Mid\_CH

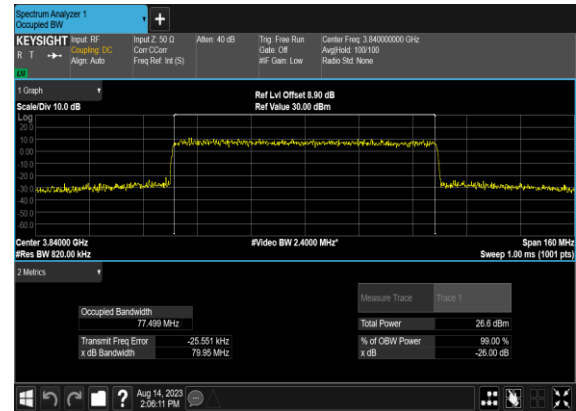

### N77(80M)\_CP-OFDM\_64 QAM\_Outer\_Full\_Mid\_CH

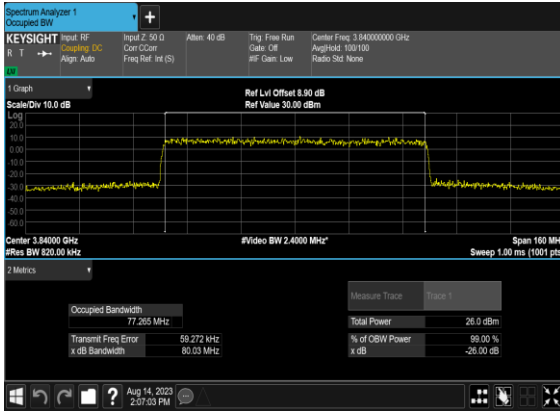

### N77(80M)\_CP-OFDM\_256 QAM\_Outer\_Full\_Mid\_CH

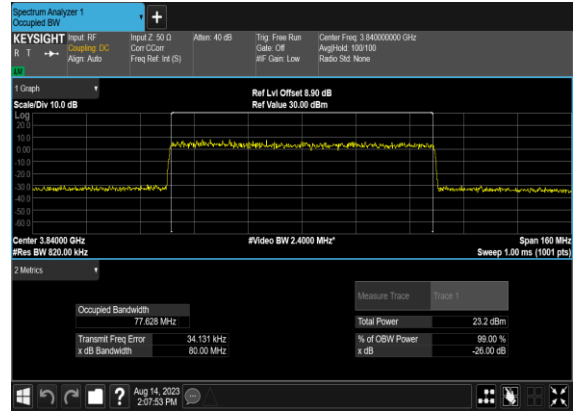

### N77(90M)\_CP- OFDM\_QPSK\_Outer\_Full\_Mid\_CH

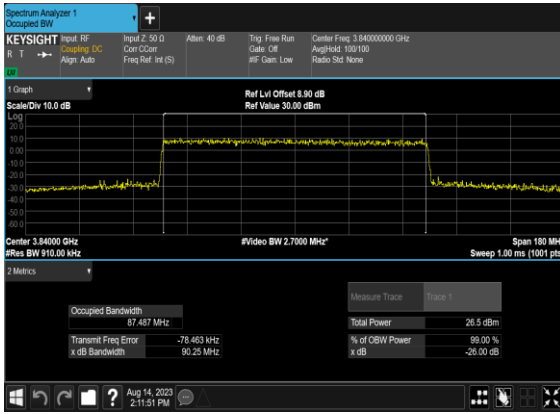

### N77(90M)\_CP-OFDM\_16 QAM\_Outer\_Full\_Mid\_CH



### N77(90M)\_CP-OFDM\_64 QAM\_Outer\_Full\_Mid\_CH

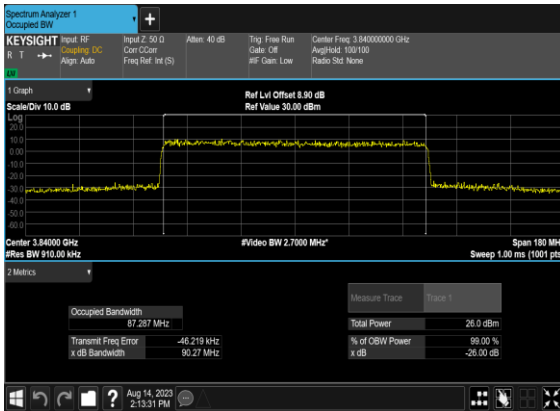

### N77(90M)\_CP-OFDM\_256 QAM\_Outer\_Full\_Mid\_CH

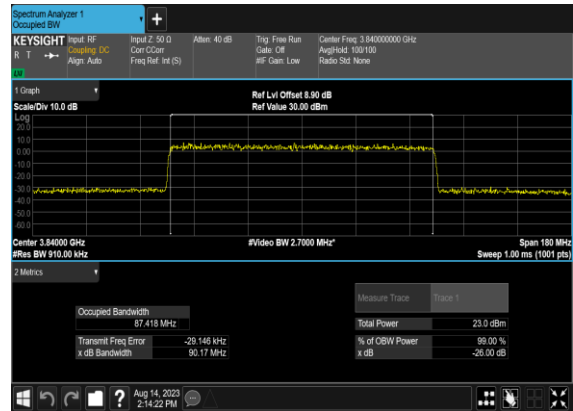

### N77(100M)\_CP-OFDM\_QPSK\_Outer\_Full\_Mid\_CH

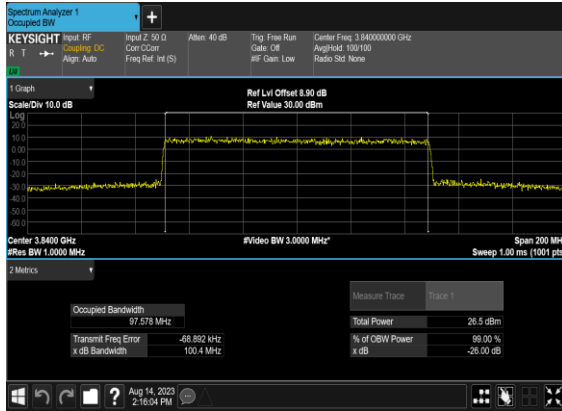

### N77(100M)\_CP-OFDM\_16QAM\_Outer\_Full\_Mid\_CH

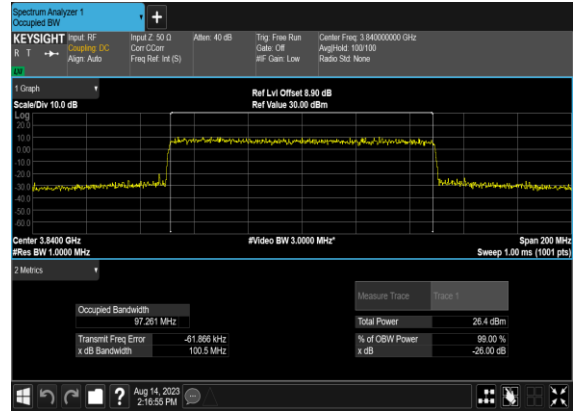

### N77(100M)\_CP-OFDM\_64QAM\_Outer\_Full\_Mid\_CH



### N77(100M)\_CP-OFDM\_256QAM\_Outer\_Full\_Mid\_CH

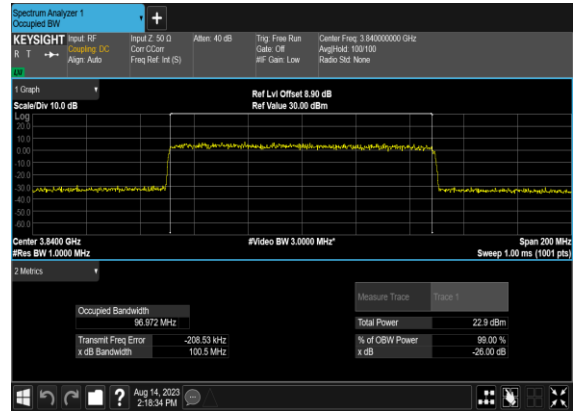

## Conducted Spurious Emissions

NR Band	SCS (kHz)	Bandwidth (MHz)	Arfcn	Freq (MHz)	Modulation	RB	Result	Verdict
77	30	20	647334	3710.01	DFT-s-OFDM BPSK	1@0	see graph	---
77	30	20	647334	3710.01	DFT-s-OFDM BPSK	1@0	see graph	PASS
77	30	20	647334	3710.01	DFT-s-OFDM BPSK	1@0	see graph	PASS
77	30	20	647334	3710.01	DFT-s-OFDM QPSK	1@0	see graph	---
77	30	20	647334	3710.01	DFT-s-OFDM QPSK	1@0	see graph	PASS
77	30	20	647334	3710.01	DFT-s-OFDM QPSK	1@0	see graph	PASS
77	30	20	656000	3840.0	DFT-s-OFDM BPSK	1@0	see graph	---
77	30	20	656000	3840.0	DFT-s-OFDM BPSK	1@0	see graph	PASS
77	30	20	656000	3840.0	DFT-s-OFDM BPSK	1@0	see graph	PASS
77	30	20	656000	3840.0	DFT-s-OFDM QPSK	1@0	see graph	---
77	30	20	656000	3840.0	DFT-s-OFDM QPSK	1@0	see graph	PASS
77	30	20	656000	3840.0	DFT-s-OFDM QPSK	1@0	see graph	PASS
77	30	20	664666	3969.99	DFT-s-OFDM BPSK	1@0	see graph	---
77	30	20	664666	3969.99	DFT-s-OFDM BPSK	1@0	see graph	PASS
77	30	20	664666	3969.99	DFT-s-OFDM BPSK	1@0	see graph	PASS
77	30	20	664666	3969.99	DFT-s-OFDM QPSK	1@0	see graph	---
77	30	20	664666	3969.99	DFT-s-OFDM QPSK	1@0	see graph	PASS
77	30	20	664666	3969.99	DFT-s-OFDM QPSK	1@0	see graph	PASS
77	30	60	648668	3730.02	DFT-s-OFDM BPSK	1@0	see graph	---
77	30	60	648668	3730.02	DFT-s-OFDM BPSK	1@0	see graph	PASS
77	30	60	648668	3730.02	DFT-s-OFDM BPSK	1@0	see graph	PASS
77	30	60	648668	3730.02	DFT-s-OFDM QPSK	1@0	see graph	---

77	30	60	648668	3730.02	DFT-s-OFDM QPSK	1@0	see graph	<b>PASS</b>
77	30	60	648668	3730.02	DFT-s-OFDM QPSK	1@0	see graph	<b>PASS</b>
77	30	60	656000	3840.0	DFT-s-OFDM BPSK	1@0	see graph	---
77	30	60	656000	3840.0	DFT-s-OFDM BPSK	1@0	see graph	<b>PASS</b>
77	30	60	656000	3840.0	DFT-s-OFDM BPSK	1@0	see graph	<b>PASS</b>
77	30	60	656000	3840.0	DFT-s-OFDM QPSK	1@0	see graph	---
77	30	60	656000	3840.0	DFT-s-OFDM QPSK	1@0	see graph	<b>PASS</b>
77	30	60	656000	3840.0	DFT-s-OFDM QPSK	1@0	see graph	<b>PASS</b>
77	30	60	663332	3949.98	DFT-s-OFDM BPSK	1@0	see graph	---
77	30	60	663332	3949.98	DFT-s-OFDM BPSK	1@0	see graph	<b>PASS</b>
77	30	60	663332	3949.98	DFT-s-OFDM BPSK	1@0	see graph	<b>PASS</b>
77	30	60	663332	3949.98	DFT-s-OFDM QPSK	1@0	see graph	---
77	30	60	663332	3949.98	DFT-s-OFDM QPSK	1@0	see graph	<b>PASS</b>
77	30	60	663332	3949.98	DFT-s-OFDM QPSK	1@0	see graph	<b>PASS</b>
77	30	100	650000	3750.0	DFT-s-OFDM BPSK	1@0	see graph	---
77	30	100	650000	3750.0	DFT-s-OFDM BPSK	1@0	see graph	<b>PASS</b>
77	30	100	650000	3750.0	DFT-s-OFDM BPSK	1@0	see graph	<b>PASS</b>
77	30	100	650000	3750.0	DFT-s-OFDM QPSK	1@0	see graph	---
77	30	100	650000	3750.0	DFT-s-OFDM QPSK	1@0	see graph	<b>PASS</b>
77	30	100	650000	3750.0	DFT-s-OFDM QPSK	1@0	see graph	<b>PASS</b>
77	30	100	656000	3840.0	DFT-s-OFDM BPSK	1@0	see graph	---
77	30	100	656000	3840.0	DFT-s-OFDM BPSK	1@0	see graph	<b>PASS</b>
77	30	100	656000	3840.0	DFT-s-OFDM BPSK	1@0	see graph	<b>PASS</b>
77	30	100	656000	3840.0	DFT-s-OFDM QPSK	1@0	see graph	---



<b>77</b>	30	100	656000	3840.0	DFT-s-OFDM QPSK	1@0	see graph	<b>PASS</b>
<b>77</b>	30	100	656000	3840.0	DFT-s-OFDM QPSK	1@0	see graph	<b>PASS</b>
<b>77</b>	30	100	662000	3930.0	DFT-s-OFDM BPSK	1@0	see graph	---
<b>77</b>	30	100	662000	3930.0	DFT-s-OFDM BPSK	1@0	see graph	<b>PASS</b>
<b>77</b>	30	100	662000	3930.0	DFT-s-OFDM BPSK	1@0	see graph	<b>PASS</b>
<b>77</b>	30	100	662000	3930.0	DFT-s-OFDM QPSK	1@0	see graph	---
<b>77</b>	30	100	662000	3930.0	DFT-s-OFDM QPSK	1@0	see graph	<b>PASS</b>
<b>77</b>	30	100	662000	3930.0	DFT-s-OFDM QPSK	1@0	see graph	<b>PASS</b>

### N77(20M)\_DFT-s-OFDM\_BPSK\_Edge\_1RB\_Left\_Low\_CH

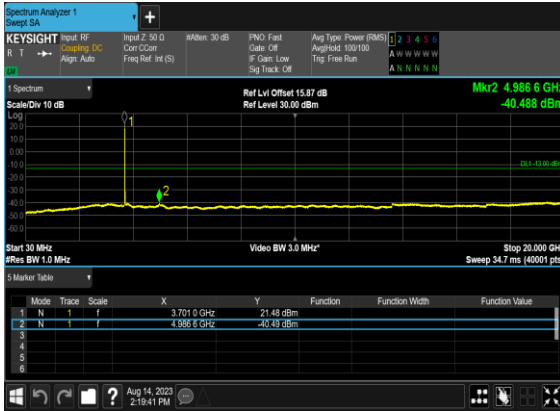

### N77(20M)\_DFT-s-OFDM\_BPSK\_Edge\_1RB\_Left\_Low\_CH

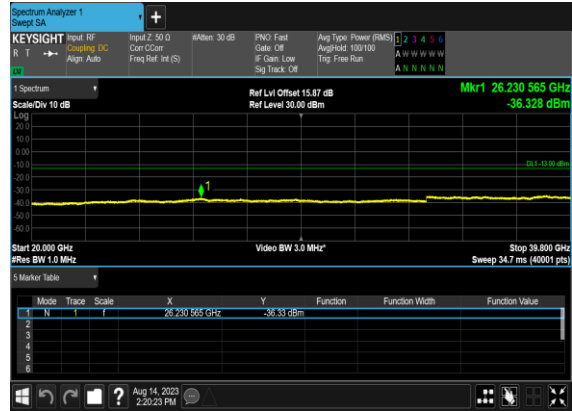

### N77(20M)\_DFT-s-OFDM\_QPSK\_Edge\_1RB\_Left\_Low\_CH

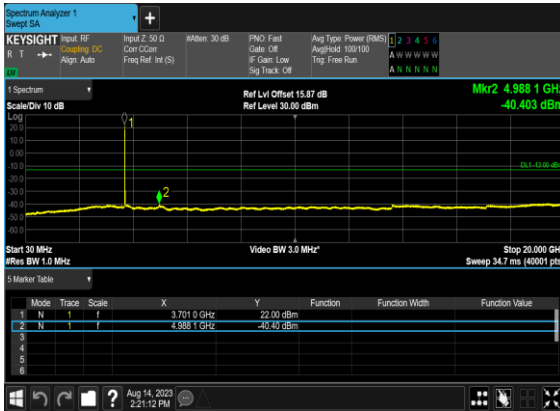

### N77(20M)\_DFT-s-OFDM\_QPSK\_Edge\_1RB\_Left\_Low\_CH

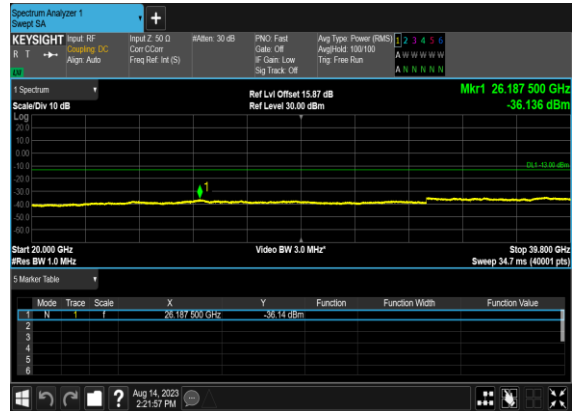

### N77(20M)\_DFT-s-OFDM\_BPSK\_Edge\_1RB\_Left\_Mid\_CH

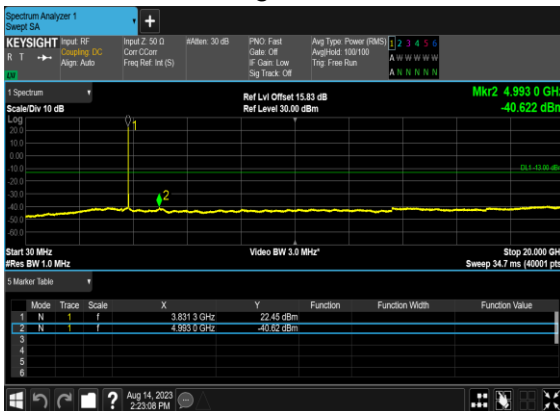

### N77(20M)\_DFT-s-OFDM\_BPSK\_Edge\_1RB\_Left\_Mid\_CH

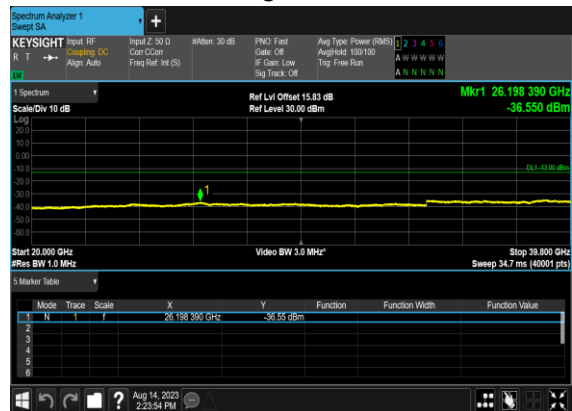

N77(20M)\_DFT-s-OFDM\_QPSK\_Edge\_1RB\_Left\_Mid\_CH



N77(20M)\_DFT-s-OFDM\_QPSK\_Edge\_1RB\_Left\_Mid\_CH

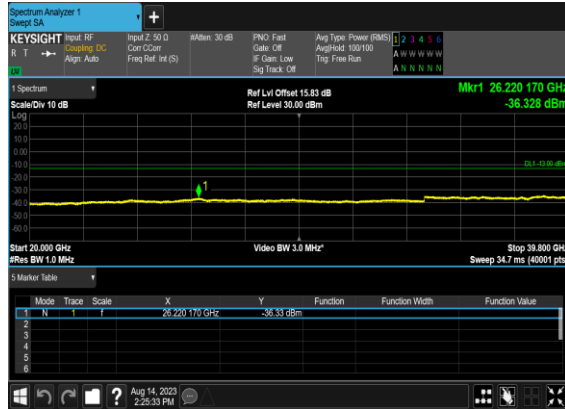

N77(20M)\_DFT-s-OFDM\_BPSK\_Edge\_1RB\_Left\_High\_CH



N77(20M)\_DFT-s-OFDM\_BPSK\_Edge\_1RB\_Left\_High\_CH



N77(20M)\_DFT-s-OFDM\_QPSK\_Edge\_1RB\_Left\_High\_CH

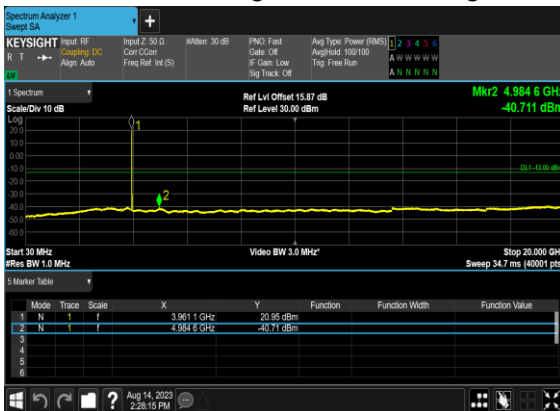

N77(20M)\_DFT-s-OFDM\_QPSK\_Edge\_1RB\_Left\_High\_CH

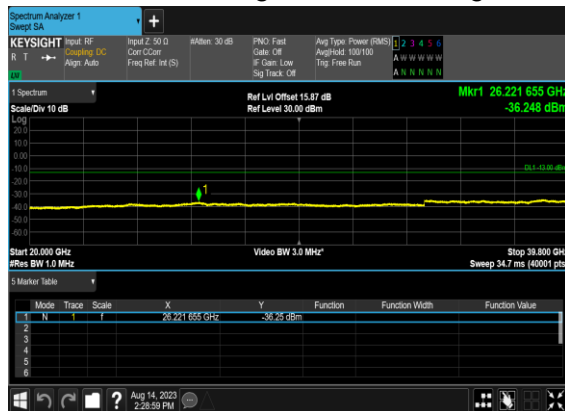

N77(60M)\_DFT-s-OFDM\_BPSK\_Edge\_1RB\_Left\_Low\_CH



N77(60M)\_DFT-s-OFDM\_BPSK\_Edge\_1RB\_Left\_Low\_CH

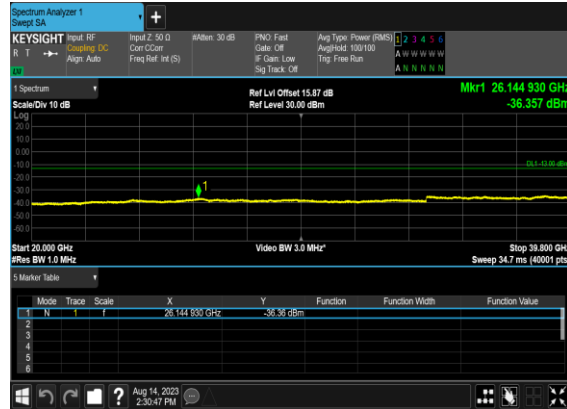

N77(60M)\_DFT-s-OFDM\_QPSK\_Edge\_1RB\_Left\_Low\_CH



N77(60M)\_DFT-s-OFDM\_QPSK\_Edge\_1RB\_Left\_Low\_CH

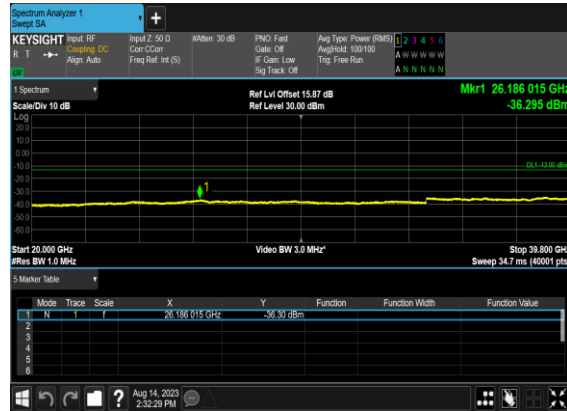

N77(60M)\_DFT-s-OFDM\_BPSK\_Edge\_1RB\_Left\_Mid\_CH

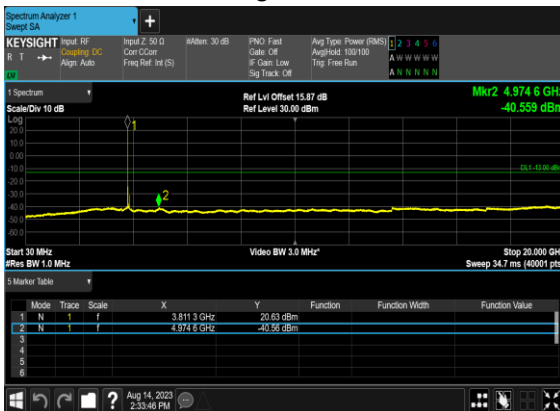

N77(60M)\_DFT-s-OFDM\_BPSK\_Edge\_1RB\_Left\_Mid\_CH

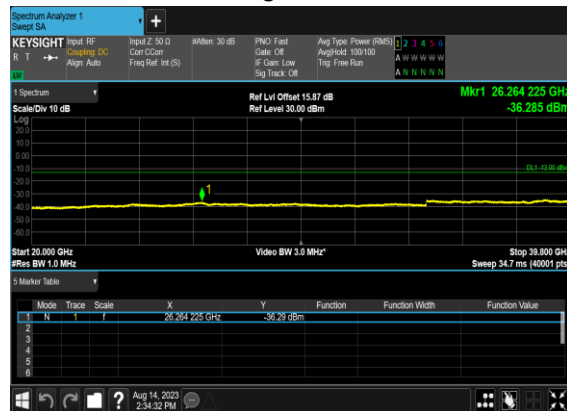

N77(60M)\_DFT-s-OFDM\_QPSK\_Edge\_1RB\_Left\_Mid\_CH

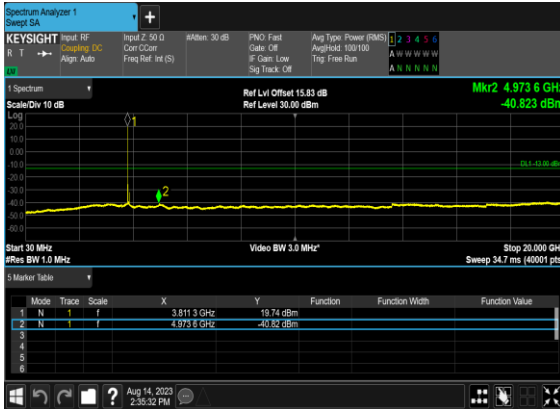

N77(60M)\_DFT-s-OFDM\_QPSK\_Edge\_1RB\_Left\_Mid\_CH

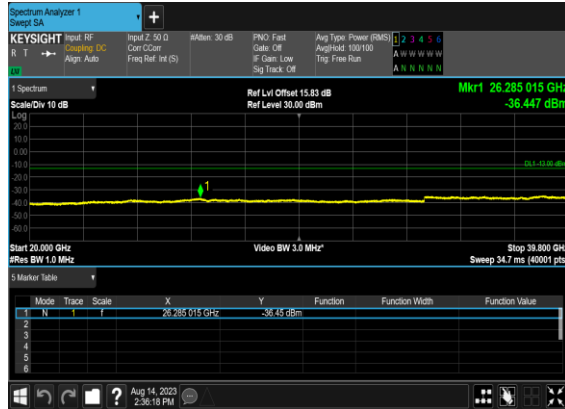

N77(60M)\_DFT-s-OFDM\_BPSK\_Edge\_1RB\_Left\_High\_CH

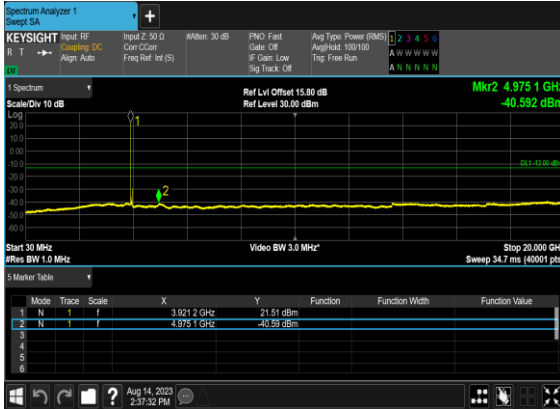

N77(60M)\_DFT-s-OFDM\_BPSK\_Edge\_1RB\_Left\_High\_CH

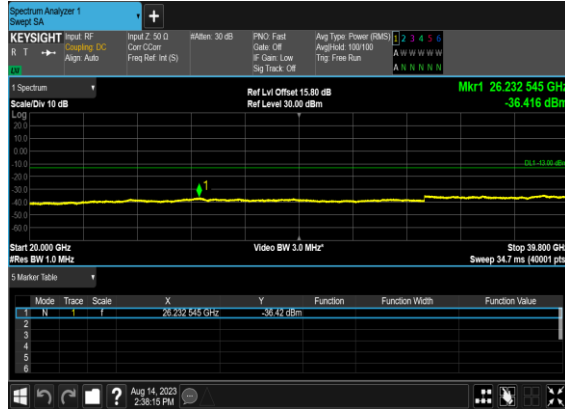

N77(60M)\_DFT-s-OFDM\_QPSK\_Edge\_1RB\_Left\_High\_CH

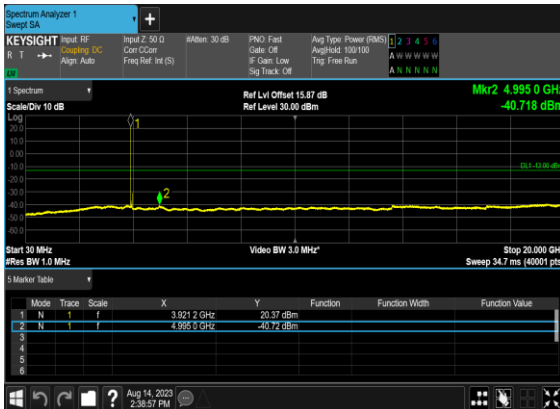

N77(60M)\_DFT-s-OFDM\_QPSK\_Edge\_1RB\_Left\_High\_CH

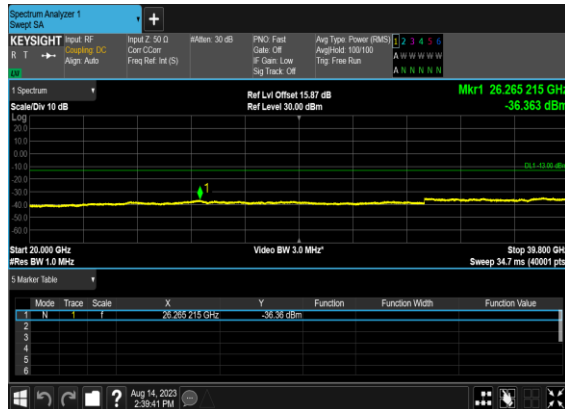

N77(100M)\_DFT-s-OFDM\_BPSK\_Edge\_1RB\_Left\_Low\_CH

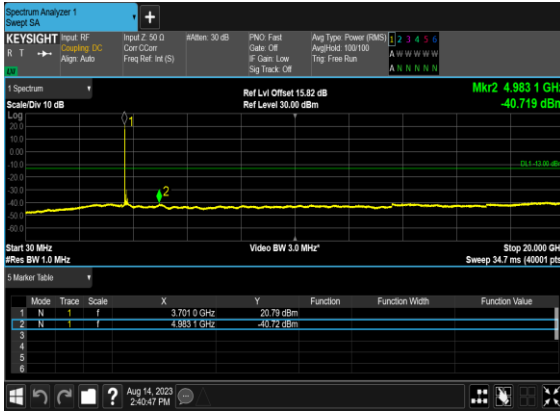

N77(100M)\_DFT-s-OFDM\_BPSK\_Edge\_1RB\_Left\_Low\_CH

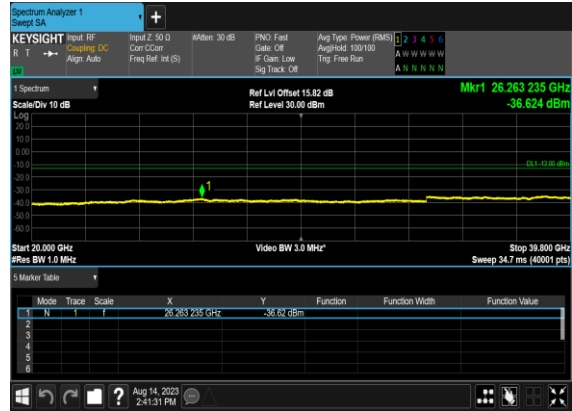

N77(100M)\_DFT-s-OFDM\_QPSK\_Edge\_1RB\_Left\_Low\_CH



N77(100M)\_DFT-s-OFDM\_QPSK\_Edge\_1RB\_Left\_Low\_CH

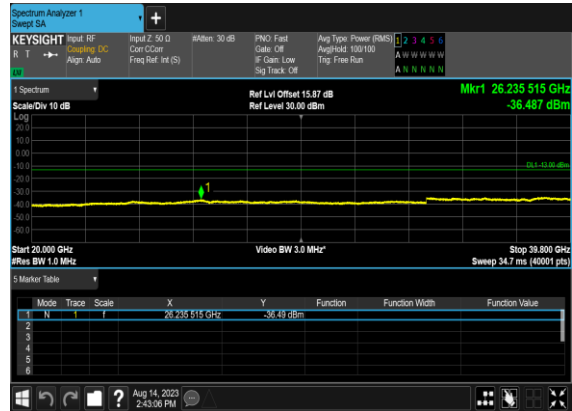

N77(100M)\_DFT-s-OFDM\_BPSK\_Edge\_1RB\_Left\_Mid\_CH

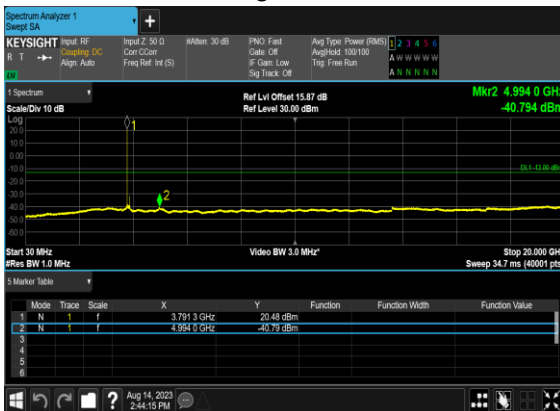

N77(100M)\_DFT-s-OFDM\_BPSK\_Edge\_1RB\_Left\_Mid\_CH

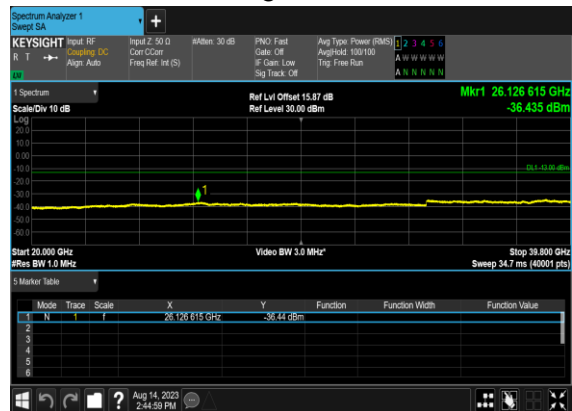

### N77(100M)\_DFT-s-OFDM\_QPSK\_Edge\_1RB\_Left\_Mid\_CH

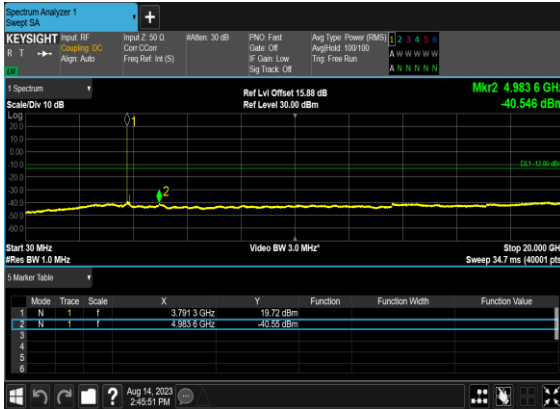

### N77(100M)\_DFT-s-OFDM\_QPSK\_Edge\_1RB\_Left\_Mid\_CH

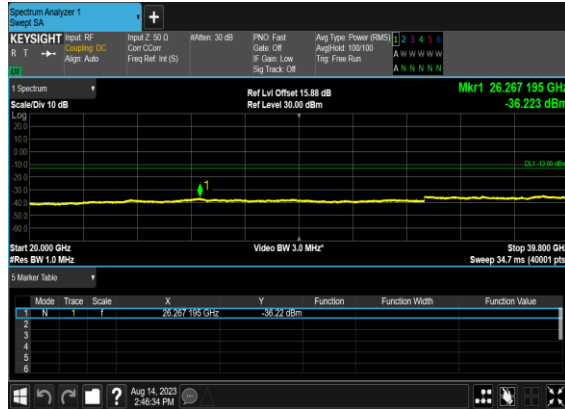

### N77(100M)\_DFT-s-OFDM\_BPSK\_Edge\_1RB\_Left\_High\_CH

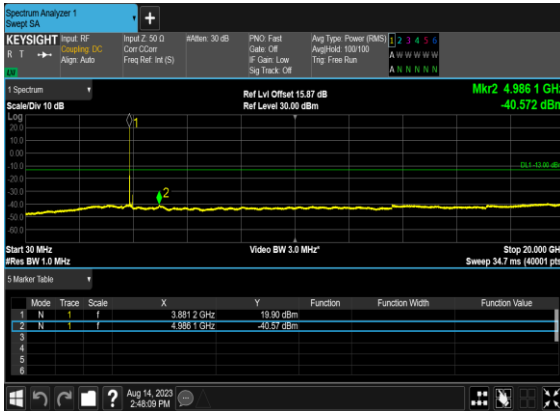

### N77(100M)\_DFT-s-OFDM\_BPSK\_Edge\_1RB\_Left\_High\_CH

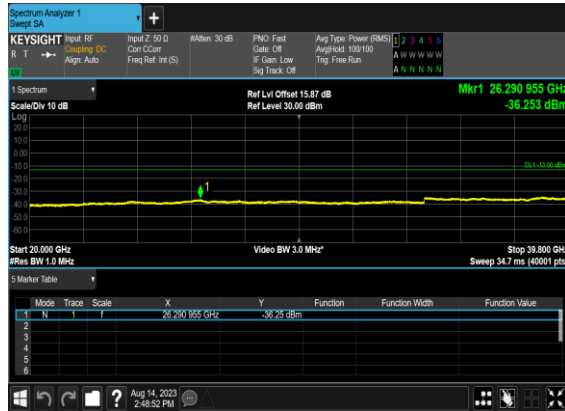

### N77(100M)\_DFT-s-OFDM\_QPSK\_Edge\_1RB\_Left\_High\_CH

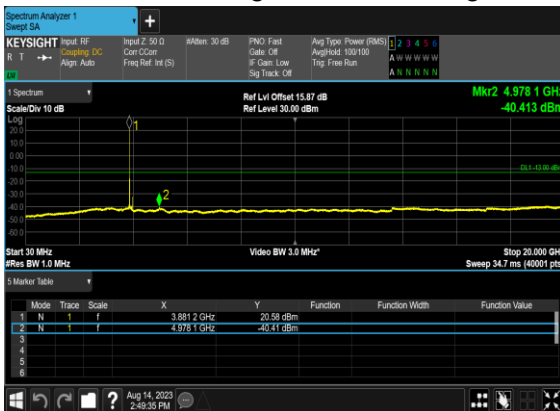

### N77(100M)\_DFT-s-OFDM\_QPSK\_Edge\_1RB\_Left\_High\_CH

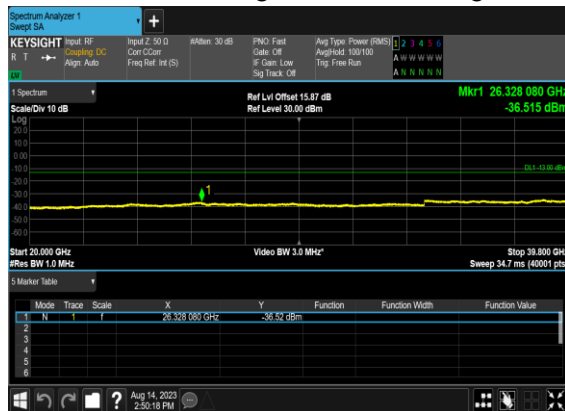

## Conducted Band Edge

NR Band	SCS (kHz)	Bandwidth (MHz)	Arfcn	Freq (MHz)	Modulation	RB	Result	Verdict
77	30	20	647334	3710.01	DFT-s-OFDM BPSK	1@0	see graph	PASS
77	30	20	647334	3710.01	DFT-s-OFDM QPSK	1@0	see graph	PASS
77	30	20	647334	3710.01	DFT-s-OFDM BPSK	50@0	see graph	PASS
77	30	20	647334	3710.01	DFT-s-OFDM QPSK	50@0	see graph	PASS
77	30	20	664666	3969.99	DFT-s-OFDM BPSK	1@50	see graph	PASS
77	30	20	664666	3969.99	DFT-s-OFDM QPSK	1@50	see graph	PASS
77	30	20	664666	3969.99	DFT-s-OFDM BPSK	50@0	see graph	PASS
77	30	20	664666	3969.99	DFT-s-OFDM QPSK	50@0	see graph	PASS
77	30	60	648668	3730.02	DFT-s-OFDM BPSK	1@0	see graph	PASS
77	30	60	648668	3730.02	DFT-s-OFDM QPSK	1@0	see graph	PASS
77	30	60	648668	3730.02	DFT-s-OFDM BPSK	162@0	see graph	PASS
77	30	60	648668	3730.02	DFT-s-OFDM QPSK	162@0	see graph	PASS
77	30	60	663332	3949.98	DFT-s-OFDM BPSK	1@161	see graph	PASS
77	30	60	663332	3949.98	DFT-s-OFDM QPSK	1@161	see graph	PASS
77	30	60	663332	3949.98	DFT-s-OFDM BPSK	162@0	see graph	PASS
77	30	60	663332	3949.98	DFT-s-OFDM QPSK	162@0	see graph	PASS
77	30	100	650000	3750.0	DFT-s-OFDM BPSK	1@0	see graph	PASS
77	30	100	650000	3750.0	DFT-s-OFDM QPSK	1@0	see graph	PASS
77	30	100	650000	3750.0	DFT-s-OFDM BPSK	270@0	see graph	PASS
77	30	100	650000	3750.0	DFT-s-OFDM QPSK	270@0	see graph	PASS
77	30	100	662000	3930.0	DFT-s-OFDM BPSK	1@272	see graph	PASS
77	30	100	662000	3930.0	DFT-s-OFDM QPSK	1@272	see graph	PASS
77	30	100	662000	3930.0	DFT-s-OFDM BPSK	270@0	see graph	PASS
77	30	100	662000	3930.0	DFT-s-OFDM QPSK	270@0	see graph	PASS



N77(20M)\_DFT-s-  
OFDM\_BPSK\_Edge\_1RB\_Left\_Low\_CH

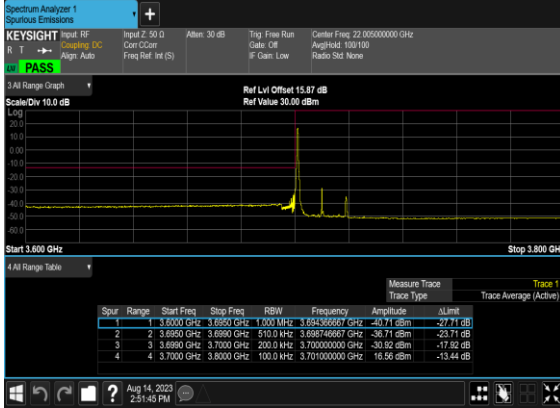

N77(20M)\_DFT-s-  
OFDM\_QPSK\_Edge\_1RB\_Left\_Low\_CH

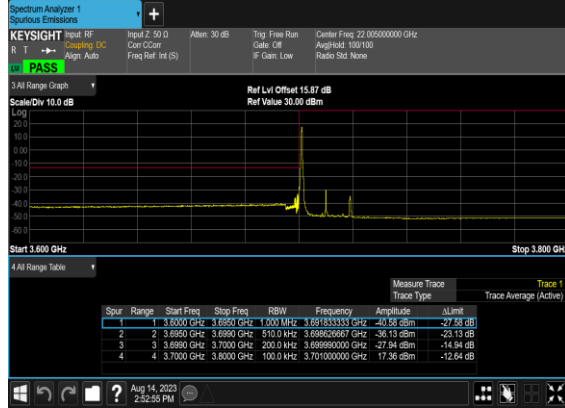

N77(20M)\_DFT-s-  
OFDM\_BPSK\_Outer\_Full\_Low\_CH

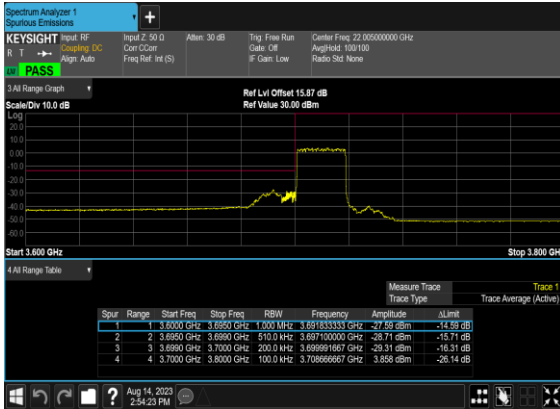

N77(20M)\_DFT-s-  
OFDM\_QPSK\_Outer\_Full\_Low\_CH

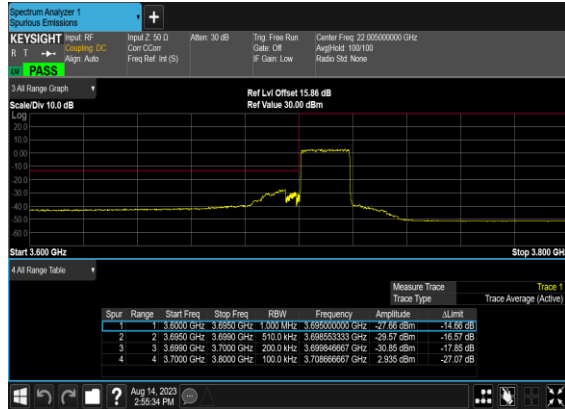

N77(20M)\_DFT-s-  
OFDM\_BPSK\_Edge\_1RB\_Right\_High\_CH

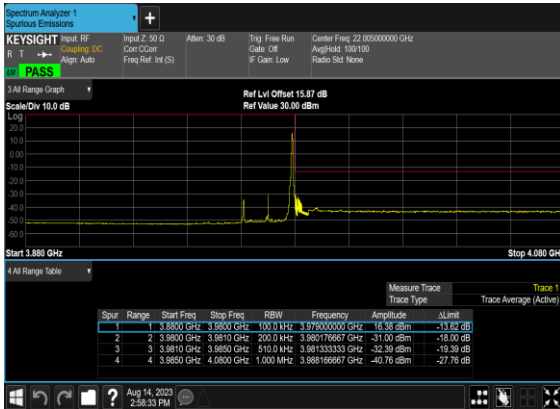

N77(20M)\_DFT-s-  
OFDM\_QPSK\_Edge\_1RB\_Right\_High\_CH

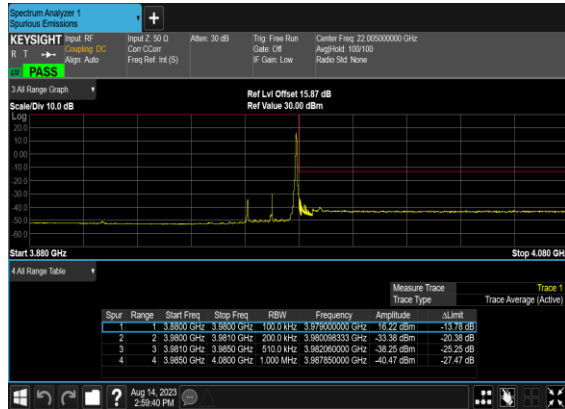

N77(20M)\_DFT-s-OFDM\_BPSK\_Outer\_Full\_High\_CH

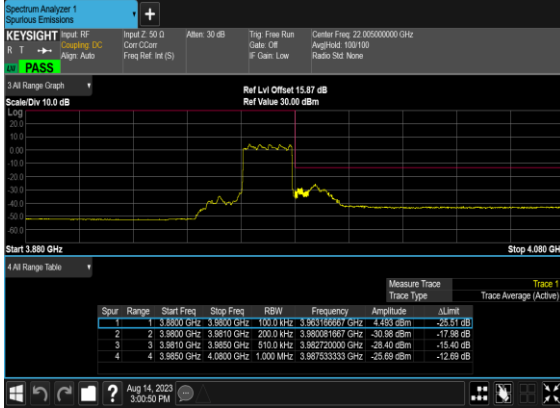

N77(20M)\_DFT-s-OFDM\_QPSK\_Outer\_Full\_High\_CH



N77(60M)\_DFT-s-OFDM\_BPSK\_Edge\_1RB\_Left\_Low\_CH

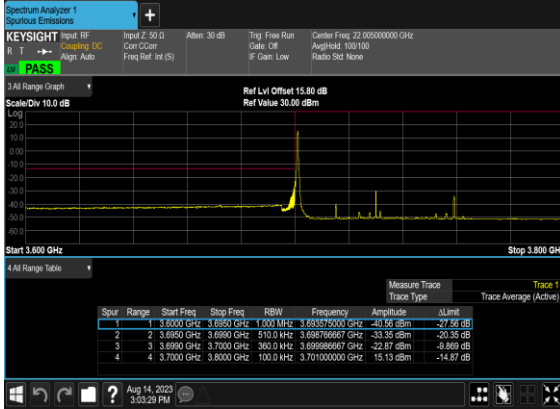

N77(60M)\_DFT-s-OFDM\_QPSK\_Edge\_1RB\_Left\_Low\_CH

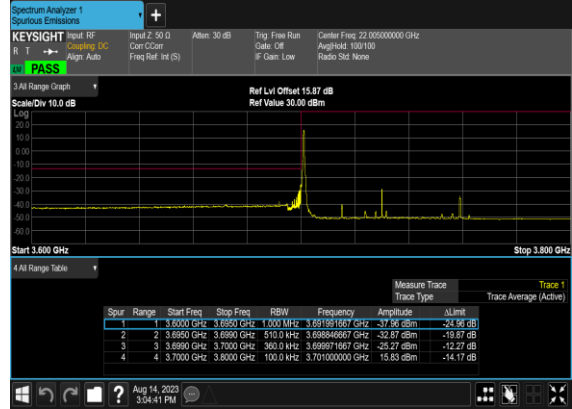

N77(60M)\_DFT-s-OFDM\_BPSK\_Outer\_Full\_Low\_CH

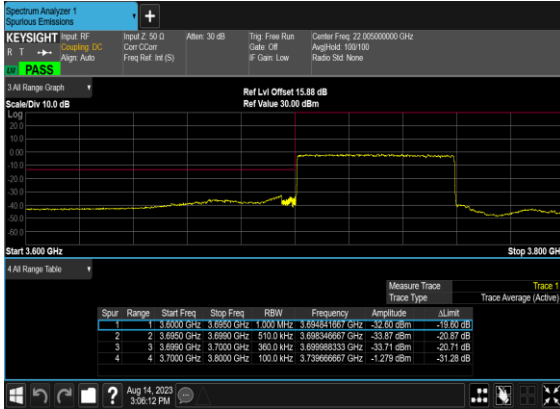

N77(60M)\_DFT-s-OFDM\_QPSK\_Outer\_Full\_Low\_CH

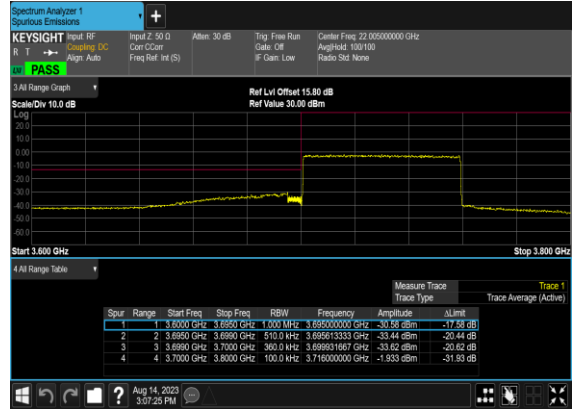

### N77(60M)\_DFT-s-OFDM\_BPSK\_Edge\_1RB\_Right\_High\_CH

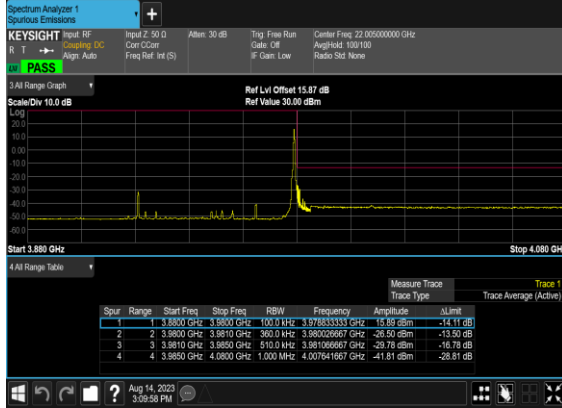

### N77(60M)\_DFT-s-OFDM\_QPSK\_Edge\_1RB\_Right\_High\_CH

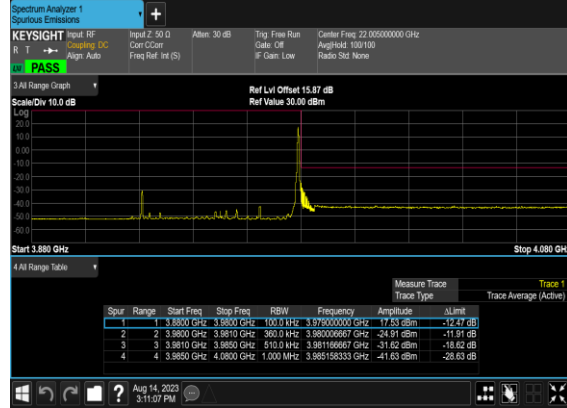

### N77(60M)\_DFT-s-OFDM\_BPSK\_Outer\_Full\_High\_CH



### N77(60M)\_DFT-s-OFDM\_QPSK\_Outer\_Full\_High\_CH

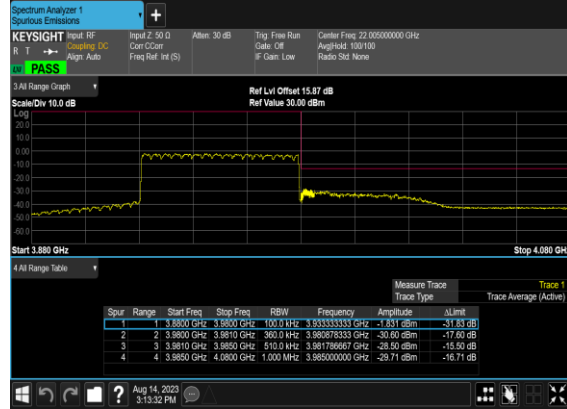

### N77(100M)\_DFT-s-OFDM\_BPSK\_Edge\_1RB\_Left\_Low\_CH

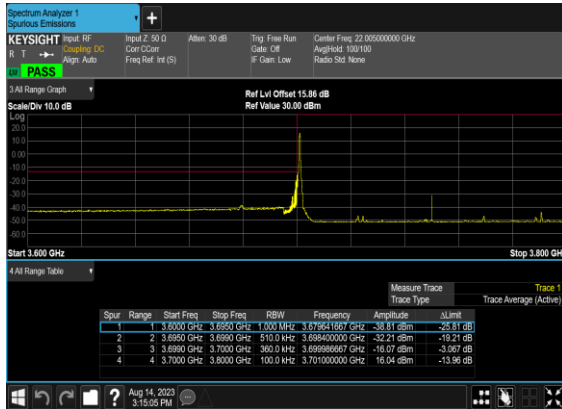

### N77(100M)\_DFT-s-OFDM\_QPSK\_Edge\_1RB\_Left\_Low\_CH

