



FCC RF Test Report

APPLICANT : Xiaomi Communications Co., Ltd.
EQUIPMENT : Mobile Phone
BRAND NAME : Redmi
MODEL NAME : 24090RA29G
FCC ID : 2AFZZRA29G
STANDARD : 47 CFR Part 22, 24, 27
CLASSIFICATION : PCS Licensed Transmitter Held to Ear (PCE)
TEST DATE(S) : Jul. 23, 2024 ~ Jul. 29, 2024

We, Sporton International Inc. (Kunshan), would like to declare that the tested sample has been evaluated in accordance with the procedures given in ANSI C63.26-2015 and shown compliance with the applicable technical standards.

The test results in this report apply exclusively to the tested model / sample. Without written approval of Sporton International Inc. (Kunshan), the test report shall not be reproduced except in full.

Jason Jia

Approved by: Jason Jia



Sporton International Inc. (Kunshan)

**No. 1098, Pengxi North Road, Kunshan Economic Development Zone Jiangsu Province 215300
People's Republic of China**



TABLE OF CONTENTS

REVISION HISTORY... 3
SUMMARY OF TEST RESULT ... 4
1 GENERAL DESCRIPTION ... 5
1.1 Applicant ... 5
1.2 Manufacturer ... 5
1.3 Product Feature of Equipment Under Test ... 5
1.4 Product Specification of Equipment Under Test ... 5
1.5 Modification of EUT ... 6
1.6 Maximum ERP/EIRP and Emission Designator ... 6
1.7 Testing Location ... 7
1.8 Test Software ... 7
1.9 Applicable Standards ... 8
2 TEST CONFIGURATION OF EQUIPMENT UNDER TEST ... 9
2.1 Test Mode ... 9
2.2 Connection Diagram of Test System ... 10
2.3 Support Unit used in test configuration and system ... 10
2.4 Measurement Results Explanation Example ... 11
2.5 Frequency List of Low/Middle/High Channels ... 11
3 CONDUCTED TEST ITEMS ... 13
3.1 Measuring Instruments ... 13
3.2 Test Setup ... 13
3.3 Test Result of Conducted Test ... 13
3.4 Conducted Output Power and ERP/EIRP ... 14
3.5 Peak-to-Average Ratio ... 15
3.6 Occupied Bandwidth ... 16
3.7 Conducted Band Edge ... 17
3.8 Conducted Spurious Emission ... 19
3.9 Frequency Stability ... 20
4 RADIATED TEST ITEMS ... 21
4.1 Measuring Instruments ... 21
4.2 Test Setup ... 21
4.3 Test Result of Radiated Test ... 22
4.4 Radiated Spurious Emission ... 23
5 LIST OF MEASURING EQUIPMENT ... 24
6 MEASUREMENT UNCERTAINTY ... 25
APPENDIX A. TEST RESULTS OF CONDUCTED TEST
APPENDIX B. TEST RESULTS OF RADIATED TEST
APPENDIX C. TEST SETUP PHOTOGRAPHS



SUMMARY OF TEST RESULT

Report Section	FCC Rule	Description	Limit	Result	Remark
3.4	§2.1046	Conducted Output Power	Reporting Only	PASS	-
	§22.913(a)(5)	Effective Radiated Power (5G NR n5)	ERP < 7 Watt		
	§24.232(c)	Equivalent Isotropic Radiated Power (5G NR n2)	EIRP < 2Watt		
	§27.50(d)(4)	Equivalent Isotropic Radiated Power (5G NR n66)	EIRP < 1Watt		
3.5	§24.232(d) §27.50(j)(4)	Peak-to-Average Ratio	<13 dB	PASS	-
3.6	§2.1049	Occupied Bandwidth	Reporting Only	PASS	-
3.7	§2.1051 §22.917(a) §24.238(a) §27.53(h)	Conducted Band Edge Measurement (5G NR n5) (5G NR n2) (5G NR n66)	< 43+10log10(P[Watts])	PASS	-
3.8	§2.1051 §22.917(a) §24.238(a) §27.53(h)	Conducted Spurious Emission (5G NR n5) (5G NR n2) (5G NR n66)	< 43+10log10(P[Watts])	PASS	-
3.9	§2.1055 §22.355	Frequency Stability Temperature & Voltage	< 2.5 ppm for Part 22	PASS	-
	§24.235 §27.54		Within Authorized Band		
4.4	§2.1053 §22.917(a) §24.238(a) §27.53(h)	Radiated Spurious Emission (5G NR n5) (5G NR n2) (5G NR n66)	< 43+10log ₁₀ (P[Watts])	PASS	Under limit 33.15 dB at 3450.00 MHz

Conformity Assessment Condition:

- The test results (PASS/FAIL) with all measurement uncertainty excluded are presented against the regulation limits or in accordance with the requirements stipulated by the applicant/manufacturer who shall bear all the risks of non-compliance that may potentially occur if measurement uncertainty is taken into account.
- The measurement uncertainty please refer to each test result in the section "Measurement Uncertainty"

Disclaimer:

The product specifications of the EUT presented in the test report that may affect the test assessments are declared by the manufacturer who shall take full responsibility for the authenticity.



1 General Description

1.1 Applicant

Xiaomi Communications Co., Ltd.

#019, 9th Floor, Building 6, 33 Xi'erqi Middle Road, Haidian District, Beijing, China, 100085

1.2 Manufacturer

Xiaomi Communications Co., Ltd.

#019, 9th Floor, Building 6, 33 Xi'erqi Middle Road, Haidian District, Beijing, China, 100085

1.3 Product Feature of Equipment Under Test

Product Feature	
Equipment	Mobile Phone
Brand Name	Redmi
Model Name	24090RA29G
FCC ID	2AFZZRA29G
IMEI Code	Conducted: 861793070041148/861793070041155 Radiation: 861793070039324/861793070039332
HW Version	135300O16
SW Version	Xiaomi HyperOS 1.0
EUT Stage	Identical Prototype

1.4 Product Specification of Equipment Under Test

Standards-related Product Specification	
Tx Frequency	5G NR n2 : 1850 MHz ~ 1910 MHz 5G NR n5 : 824 MHz ~ 849 MHz 5G NR n66 : 1710 MHz ~ 1780 MHz
Rx Frequency	5G NR n2 : 1930 MHz ~ 1990 MHz 5G NR n5 : 869 MHz ~ 894 MHz 5G NR n66 : 2110 MHz~ 2200 MHz
Bandwidth	n2, n5: 5MHz / 10MHz / 15MHz / 20MHz n66: 5MHz / 10MHz / 15MHz / 20MHz / 25MHz / 30MHz / 40MHz
SCS	15kHz
Antenna Gain	<Ant. 1>: n2 : -0.7 dBi n5 : -4.0 dBi n66 : 0.77 dBi <Ant. 2>: n2 : -3.8 dBi n66 : -5.6 dBi <Ant. 4>: n2 : -0.7 dBi n5 : -5.9 dBi



	n66 : -1.0 dBi
Type of Modulation	CP-OFDM: QPSK / 16QAM / 64QAM / 256QAM DFT-s-OFDM: PI/2 BPSK / QPSK / 16QAM / 64QAM / 256QAM

Remark:

1. The maximum ERP/EIRP is calculated from max output power and max antenna gain, only the maximum ERP/EIRP of ANT 1 for 5G NR n2/n5/n66 are shown in the report.
2. All the supported ENDC combinations are verified conducted power, only the ENDC combination with highest power are shown in the report.
3. 5G NR n2 only support SA mode, and n5/n66 support SA & NSA mode. According to the maximum power between SA and NSA mode, SA covers NSA mode.
4. The device supports two PAs for 5G NR n2/n66 (main PA for SA mode and other PA for NSA mode), the maximum power of main PA is higher than the other PA, therefore, we chose higher power PA to calculate the EIRP and show in the report.
5. The EN-DC mode combination could be referred to the product spec.

1.5 Modification of EUT

No modifications are made to the EUT during all test items.

1.6 Maximum ERP/EIRP and Emission Designator

5G NR n2		PI/2 BPSK / QPSK		16QAM / 64QAM / 256QAM	
BW (MHz)	Frequency Range (MHz)	Maximum EIRP(W)	Emission Designator (99%OBW)	Maximum EIRP(W)	Emission Designator (99%OBW)
5	1852.5 ~ 1907.5	0.1614	4M48G7D	0.1306	4M50W7D
10	1855.0 ~ 1905.0	0.1622	9M29G7D	0.1377	9M39W7D
15	1857.5 ~ 1902.5	0.1611	14M1G7D	0.1346	14M1W7D
20	1860.0 ~ 1900.0	0.1633	18M9G7D	0.1343	18M9W7D

5G NR n5		PI/2 BPSK / QPSK		16QAM / 64QAM / 256QAM	
BW (MHz)	Frequency Range (MHz)	Maximum ERP(W)	Emission Designator (99%OBW)	Maximum ERP(W)	Emission Designator (99%OBW)
5	826.5 ~ 846.5	0.0646	4M46G7D	0.0537	4M49W7D
10	829.0 ~ 844.0	0.0658	9M26G7D	0.0546	9M28W7D
15	831.5 ~ 841.5	0.0644	14M1G7D	0.0530	14M1W7D
20	834.0 ~ 839.0	0.0678	18M9G7D	0.0541	18M9W7D



5G NR n66		PI/2 BPSK / QPSK		16QAM / 64QAM / 256QAM	
BW (MHz)	Frequency Range (MHz)	Maximum EIRP(W)	Emission Designator (99%OBW)	Maximum EIRP(W)	Emission Designator (99%OBW)
5	1712.5 ~ 1777.5	0.2985	4M47G7D	0.2483	4M48W7D
10	1715.0 ~ 1775.0	0.2999	9M26G7D	0.2518	9M29W7D
15	1717.5 ~ 1772.5	0.2972	14M1G7D	0.2495	14M1W7D
20	1720.0 ~ 1770.0	0.3013	18M9G7D	0.2523	19M0W7D
25	1722.5 ~ 1767.5	0.2958	23M8G7D	0.2421	23M8W7D
30	1725.0 ~ 1765.0	0.2965	28M7G7D	0.2483	28M6W7D
40	1730.0 ~ 1760.0	0.3141	38M6G7D	0.2443	38M6W7D

Note: All modulations have been tested, only the worst test results of PSK & QAM are shown in the report.

1.7 Testing Location

Sporton International Inc. (Kunshan) is accredited to ISO/IEC 17025:2017 by American Association for Laboratory Accreditation with Certificate Number 5145.02.

Test Firm	Sporton International Inc. (Kunshan)		
Test Site Location	No. 1098, Pengxi North Road, Kunshan Economic Development Zone Jiangsu Province 215300 People's Republic of China TEL : +86-512-57900158		
Test Site No.	Sporton Site No.	FCC Designation No.	FCC Test Firm Registration No.
	03CH04-KS TH01-KS	CN1257	314309

1.8 Test Software

Item	Site	Manufacture	Name	Version
1.	TH01-KS	Tonscend	JS1120-3 test system China_210602	3.3.10
2.	03CH04-KS	AUDIX	E3	210616



1.9 Applicable Standards

According to the specifications of the manufacturer, the EUT must comply with the requirements of the following standards:

- ♦ 47 CFR Part 22, 24, 27
- ♦ ANSI C63.26-2015
- ♦ FCC KDB 971168 D01 Power Meas License Digital Systems v03r01
- ♦ FCC KDB 412172 D01 Determining ERP and EIRP v01r01

Remark:

All test items were verified and recorded according to the standards and without any deviation during the test.



2 Test Configuration of Equipment Under Test

2.1 Test Mode

Antenna port conducted and radiated test items are performed according to KDB 971168 D01 Power Meas License Digital Systems v03r01 with maximum output power.

For radiated measurement, pre-scanned in three orthogonal panels, X, Y, Z. The worst cases (Z plane) were recorded in this report.

The device is investigated from 30MHz to 10 times of fundamental signal for radiated spurious emission test under different RB size/offset and modulations in exploratory test. Subsequently, only the worst case emissions are reported.

Orthogonal Planes of EUT	X Plane	Y Plane	Z Plane
			

Test Items	5G NR	Bandwidth (MHz)													Modulation					RB #		Test Channel		
		5	10	15	20	25	30	40	50	60	70	80	90	100	PI/2 BPSK	QPSK	16 QAM	64 QAM	256 QAM	1	Full	L	M	H
Max. Output Power	n2	v	v	v	v	-	-	-	-	-	-	-	-	-	v	v	v	v	v	v	v	v	v	
	n5	v	v	v	v	-	-	-	-	-	-	-	-	-	v	v	v	v	v	v	v	v	v	v
	n66	v	v	v	v	v	v	v	-	-	-	-	-	-	v	v	v	v	v	v	v	v	v	v
Peak-to-Average Ratio	n2				v	-	-	-	-	-	-	-	-	-	v	v				v	v		v	
	n5				v	-	-	-	-	-	-	-	-	-	v	v				v	v		v	
	n66				v				-	-	-	-	-	-	v	v				v	v		v	
26dB and 99% Bandwidth	n2	v	v	v	v	-	-	-	-	-	-	-	-	-		v	v	v	v		v		v	
	n5	v	v	v	v	-	-	-	-	-	-	-	-	-		v	v	v	v		v		v	
	n66	v	v	v	v	v	v	v	-	-	-	-	-	-		v	v	v	v		v		v	
Conducted Band Edge	n2	v		v	v	-	-	-	-	-	-	-	-	-	v	v				v	v	v		v
	n5	v		v	v	-	-	-	-	-	-	-	-	-	v	v				v	v	v		v
	n66	v		v			v	-	-	-	-	-	-	-	v	v				v	v	v		v
Conducted Spurious Emission	n2	v		v	v	-	-	-	-	-	-	-	-	-	v	v				v		v	v	v
	n5	v		v	v	-	-	-	-	-	-	-	-	-	v	v				v		v	v	v
	n66	v		v			v	-	-	-	-	-	-	-	v	v				v		v	v	v
Frequency Stability	n2				v	-	-	-	-	-	-	-	-	-		v					v		v	
	n5				v	-	-	-	-	-	-	-	-	-		v					v		v	
	n66				v				-	-	-	-	-	-		v					v		v	
E.R.P / E.I.R.P	n2	v	v	v	v	-	-	-	-	-	-	-	-	-	v	v	v	v	v	v	v	v	v	
	n5	v	v	v	v	-	-	-	-	-	-	-	-	-	v	v	v	v	v	v	v	v	v	v
	n66	v	v	v	v	v	v	v	-	-	-	-	-	-	v	v	v	v	v	v	v	v	v	v



Test Items	5G NR	Bandwidth (MHz)													Modulation					RB #		Test Channel		
		5	10	15	20	25	30	40	50	60	70	80	90	100	PI/2 BPSK	QPSK	16 QAM	64 QAM	256 QAM	1	Full	L	M	H
Radiated Spurious Emission	n2	Worst Case																					v	
	n5	Worst Case																					v	
	n66	Worst Case																					v	
Note	1. The mark "v" means that this configuration is chosen for testing 2. The mark "-" means that this bandwidth is not supported. 3. The device is investigated from 30MHz to 10 times of fundamental signal for radiated spurious emission test under different RB size/offset and modulations in exploratory test. Subsequently, only the worst case emissions are reported. 4. Frequency Stability : Normal Voltage = 3.91V ; Low Voltage =3.60V. ; High Voltage =4.30V																							

2.2 Connection Diagram of Test System

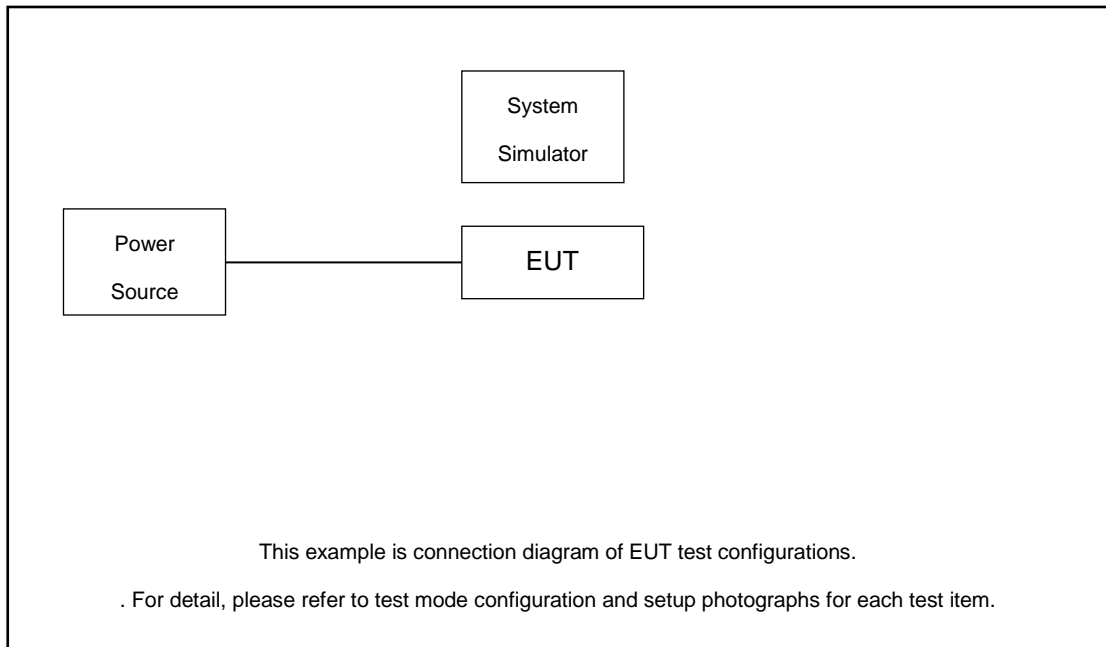

The EUT has been configuration operated in a manner tended to maximize its emission characteristics in a typical application.

2.3 Support Unit used in test configuration and system

Item	Equipment	Trade Name	Model No.	FCC ID	Data Cable	Power Cord
1.	DC Power Supply	GW	GPS-3030D	N/A	N/A	Unshielded, 1.8 m
2.	LTE Base Station	Anritsu	MT8821C	N/A	N/A	Unshielded, 1.8 m
3.	NR Base Station	Anritsu	MT8000A	N/A	N/A	Unshielded, 1.8 m



2.4 Measurement Results Explanation Example

For all conducted test items:

The offset level is set in the spectrum analyzer to compensate the RF cable loss and attenuator factor between EUT conducted output port and spectrum analyzer. With the offset compensation, the spectrum analyzer reading level is exactly the EUT RF output level.

The spectrum analyzer offset is derived from RF cable loss and attenuator factor.

$$\text{Offset} = \text{RF cable loss} + \text{attenuator factor}.$$

Following shows an offset computation example with cable loss 5.6 dB and 20dB attenuator.

Example :

$$\begin{aligned} \text{Offset(dB)} &= \text{RF cable loss(dB)} + \text{attenuator factor(dB)}. \\ &= 5.6 + 20 = 25.6 \text{ (dB)} \end{aligned}$$

2.5 Frequency List of Low/Middle/High Channels

5G NR n2 Channel and Frequency List				
BW [MHz]	Channel/Frequency(MHz)	Lowest	Middle	Highest
20	Channel	372000	376000	380000
	Frequency	1860	1880	1900
15	Channel	371500	376000	380500
	Frequency	1857.5	1880	1902.5
10	Channel	371000	376000	381000
	Frequency	1855	1880	1905
5	Channel	370500	376000	381500
	Frequency	1852.5	1880	1907.5

5G NR n5 Channel and Frequency List				
BW [MHz]	Channel/Frequency(MHz)	Lowest	Middle	Highest
20	Channel	166800	167300	167800
	Frequency	834	836.5	839
15	Channel	166300	167300	168300
	Frequency	831.5	836.5	841.5
10	Channel	165800	167300	168800
	Frequency	829	836.5	844
5	Channel	165300	167300	169300
	Frequency	826.5	836.5	846.5



5G NR n66 Channel and Frequency List				
BW [MHz]	Channel/Frequency(MHz)	Lowest	Middle	Highest
40	Channel	346000	349000	352000
	Frequency	1730	1745	1760
30	Channel	345000	349000	353000
	Frequency	1725	1745	1765
25	Channel	344500	349000	353500
	Frequency	1722.5	1745	1767.5
20	Channel	344000	349000	354000
	Frequency	1720	1745	1770
15	Channel	343500	349000	354500
	Frequency	1717.5	1745	1772.5
10	Channel	343000	349000	355000
	Frequency	1715	1745	1775
5	Channel	342500	349000	355500
	Frequency	1712.5	1745	1777.5

3 Conducted Test Items

3.1 Measuring Instruments

See list of measuring instruments of this test report.

3.2 Test Setup

3.2.1 Conducted Output Power



3.2.2 Peak-to-Average Ratio, Occupied Bandwidth ,Conducted Band-Edge and Conducted Spurious Emission

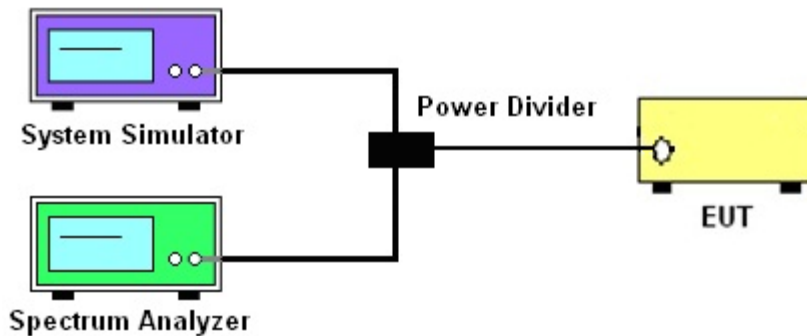

3.2.3 Frequency Stability

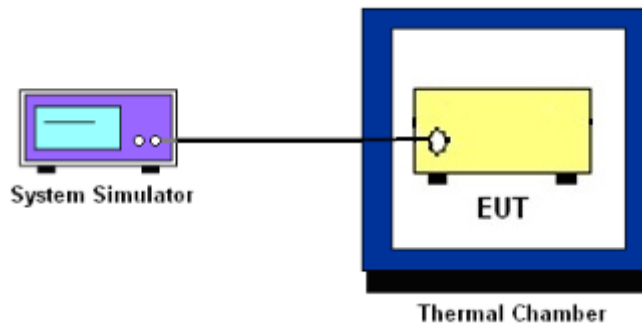

3.3 Test Result of Conducted Test

Please refer to Appendix A.



3.4 Conducted Output Power and ERP/EIRP

3.4.1 Description of the Conducted Output Power Measurement and ERP/EIRP Measurement

A system simulator was used to establish communication with the EUT. Its parameters were set to force the EUT transmitting at maximum output power. The measured power in the radio frequency on the transmitter output terminals shall be reported.

The ERP of mobile transmitters must not exceed 7 Watts for 5G NR n5.

The EIRP of mobile transmitters must not exceed 2 Watts for 5G NR n2.

The EIRP of mobile transmitters must not exceed 1 Watts for 5G NR n66.

According to KDB 412172 D01 Power Approach,

$EIRP = P_T + G_T - L_C$, $ERP = EIRP - 2.15$, where

P_T = transmitter output power in dBm

G_T = gain of the transmitting antenna in dBi

L_C = signal attenuation in the connecting cable between the transmitter and antenna in dB

3.4.2 Test Procedures

1. The testing follows ANSI C63.26 Section 5.2
2. The transmitter output port was connected to the system simulator.
3. Set EUT at maximum power through the system simulator.
4. Select lowest, middle, and highest channels for each band and different modulation.
5. Measure and record the power level from the system simulator.



3.5 Peak-to-Average Ratio

3.5.1 Description of the PAR Measurement

Power Complementary Cumulative Distribution Function (CCDF) curves provide a means for characterizing the power peaks of a digitally modulated signal on a statistical basis. A CCDF curve depicts the probability of the peak signal amplitude exceeding the average power level. Most contemporary measurement instrumentation include the capability to produce CCDF curves for an input signal provided that the instrument's resolution bandwidth can be set wide enough to accommodate the entire input signal bandwidth. In measuring transmissions in this band using an average power technique, the peak-to-average ratio (PAR) of the transmission may not exceed 13 dB.

3.5.2 Test Procedures

1. The testing follows ANSI C63.26 Section 5.2.3.4 (CCDF).
2. The EUT was connected to spectrum and system simulator via a power divider.
3. Set the CCDF (Complementary Cumulative Distribution Function) option in spectrum analyzer.
4. The highest RF powers were measured and recorded the maximum PAPR level associated with a probability of 0.1 %.
5. Record the deviation as Peak to Average Ratio.



3.6 Occupied Bandwidth

3.6.1 Description of Occupied Bandwidth Measurement

The occupied bandwidth is the width of a frequency band such that, below the lower and above the upper frequency limits, the mean powers emitted are each equal to a specified percentage 0.5% of the total mean transmitted power.

The 26 dB emission bandwidth is defined as the frequency range between two points, one above and one below the carrier frequency, at which the spectral density of the emission is attenuated 26 dB below the maximum in-band spectral density of the modulated signal. Spectral density (power per unit bandwidth) is to be measured with a detector of resolution bandwidth equal to approximately 1.0% of the emission bandwidth.

3.6.2 Test Procedures

1. The testing follows ANSI C63.26 Section 5.4
2. The EUT was connected to spectrum analyzer and system simulator via a power divider.
3. The spectrum analyzer center frequency is set to the nominal EUT channel center frequency. The span range for the spectrum analyzer shall be between two and five times the anticipated OBW.
4. The nominal resolution bandwidth (RBW) shall be in the range of 1 to 5 % of the anticipated OBW, and the VBW shall be at least 3 times the RBW.
5. Set the detection mode to peak, and the trace mode to max hold.
6. Determine the reference value: Set the EUT to transmit a modulated signal. Allow the trace to stabilize. Set the spectrum analyzer marker to the highest level of the displayed trace.
(this is the reference value)
7. Determine the “-26 dB down amplitude” as equal to (Reference Value – X).
8. Place two markers, one at the lowest and the other at the highest frequency of the envelope of the spectral display such that each marker is at or slightly below the “-X dB down amplitude” determined in step 6. If a marker is below this “-X dB down amplitude” value it shall be placed as close as possible to this value. The OBW is the positive frequency difference between the two markers.
9. Use the 99 % power bandwidth function of the spectrum analyzer and report the measured bandwidth.



3.7 Conducted Band Edge

3.7.1 Description of Conducted Band Edge Measurement

22.917(a)

For operations in the 824 – 849 MHz band, the FCC limit is $43 + 10\log_{10}(P[\text{Watts}])$ dB below the transmitter power $P(\text{Watts})$ in a 100kHz bandwidth. However, in the 1MHz bands immediately outside and adjacent to the licensee's frequency block, a resolution bandwidth of at least one percent of the emission bandwidth of the fundamental emission of the transmitter may be employed.

24.238 (a)

For operations in the 1850-1910 and 1930-1990 MHz band, the FCC limit is $43 + 10\log_{10}(P[\text{Watts}])$ dB below the transmitter power $P(\text{Watts})$ in a 1MHz bandwidth. However, in the 1 MHz bands immediately outside and adjacent to the frequency block a resolution bandwidth of at least one percent of the emission bandwidth of the fundamental emission of the transmitter may be employed.

27.53 (h)

For operations in the 1710 – 1755 MHz band, the FCC limit is $43 + 10\log_{10}(P[\text{Watts}])$ dB below the transmitter power $P(\text{Watts})$ in a 1 MHz bandwidth. However, in the 1MHz bands immediately outside and adjacent to the licensee's frequency block, a resolution bandwidth of at least one percent of the emission bandwidth of the fundamental emission of the transmitter may be employed.



3.7.2 Test Procedures

1. The testing follows ANSI C63.26 section 5.7
2. The EUT was connected to spectrum analyzer and system simulator via a power divider.
3. The band edges of low and high channels for the highest RF powers were measured.
4. Set RBW \geq 1% EBW in the 1MHz band immediately outside and adjacent to the band edge.
5. Beyond the 1 MHz band from the band edge, RBW=1MHz was used or a narrower RBW was used (generally limited to no less than 1% of the OBW) and the measured power was integrated over the full required measurement bandwidth.
6. Set spectrum analyzer with RMS detector.
7. The RF fundamental frequency should be excluded against the limit line in the operating frequency band.
8. Checked that all the results comply with the emission limit line.

Example:

The limit line is derived from $43 + 10\log(P)$ dB below the transmitter power P(Watts)

$$= P(W) - [43 + 10\log(P)] \text{ (dB)}$$

$$= [30 + 10\log(P)] \text{ (dBm)} - [43 + 10\log(P)] \text{ (dB)} = -13\text{dBm}.$$

9. When using the integration method, the starting frequency of the integration shall be centered at one-half of the RBW away from the band edge.



3.8 Conducted Spurious Emission

3.8.1 Description of Conducted Spurious Emission Measurement

The power of any emission outside of the authorized operating frequency ranges must be lower than the transmitter power (P) by a factor of at least $43 + 10 \log (P)$ dB.

It is measured by means of a calibrated spectrum analyzer and scanned from 30 MHz up to a frequency including its 10th harmonic.

3.8.2 Test Procedures

1. The testing follows ANSI C63.26 section 5.7
2. The EUT was connected to spectrum analyzer and system simulator via a power divider.
3. The RF output of EUT was connected to the spectrum analyzer by RF cable and attenuator. The path loss was compensated to the results for each measurement.
4. The middle channel for the highest RF power within the transmitting frequency was measured.
5. The conducted spurious emission for the whole frequency range was taken.
6. Make the measurement with the spectrum analyzer's RBW = 1MHz, VBW = 3MHz.
7. Set spectrum analyzer with RMS detector.
8. Taking the record of maximum spurious emission.
9. The RF fundamental frequency should be excluded against the limit line in the operating frequency band.
10. The limit line is derived from $43 + 10\log(P)$ dB below the transmitter power P(Watts)
= P(W)- [43 + 10log(P)] (dB)
= [30 + 10log(P)] (dBm) - [43 + 10log(P)] (dB)
= -13dBm.



3.9 Frequency Stability

3.9.1 Description of Frequency Stability Measurement

The frequency stability shall be measured by variation of ambient temperature and variation of primary supply voltage to ensure that the fundamental emission stays within the authorized frequency block. The frequency stability of the transmitter shall be maintained within $\pm 0.00025\%$ ($\pm 2.5\text{ppm}$) of the center frequency.

3.9.2 Test Procedures for Temperature Variation

1. The testing follows ANSI C63.26 section 5.6.4
2. The EUT was set up in the thermal chamber and connected with the system simulator.
3. With power OFF, the temperature was decreased to -30°C and the EUT was stabilized before testing. Power was applied and the maximum change in frequency was recorded within one minute.
4. With power OFF, the temperature was raised in 10°C step up to 50°C . The EUT was stabilized at each step for at least half an hour. Power was applied and the maximum frequency change was recorded within one minute.

3.9.3 Test Procedures for Voltage Variation

1. The testing follows ANSI C63.26 section 5.6.5
2. The EUT was placed in a temperature chamber at $20\pm 5^{\circ}\text{C}$ and connected with the system simulator.
3. The power supply voltage to the EUT was varied from 85% to 115% of the nominal value for other than hand carried battery equipment.
4. For hand carried, battery powered equipment, reduce the primary ac or dc supply voltage to the battery operating end point, which shall be specified by the manufacturer.
5. The variation in frequency was measured for the worst case.

4 Radiated Test Items

4.1 Measuring Instruments

See list of measuring instruments of this test report.

4.2 Test Setup

4.2.1 For radiated test below 30MHz

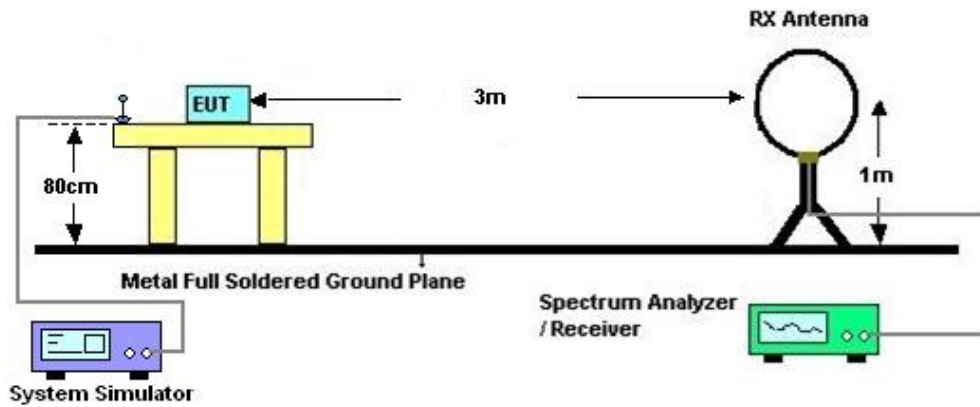

4.2.2 For radiated test from 30MHz to 1GHz

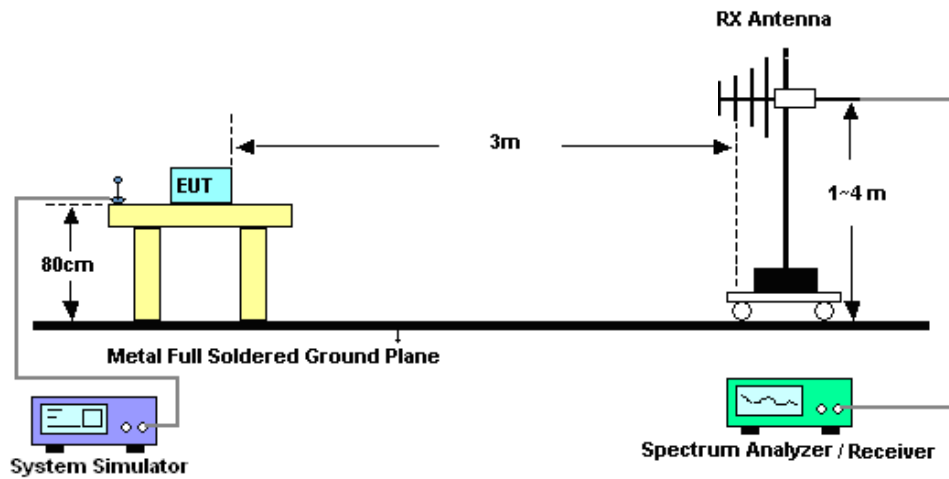

4.2.3 For radiated test above 1GHz

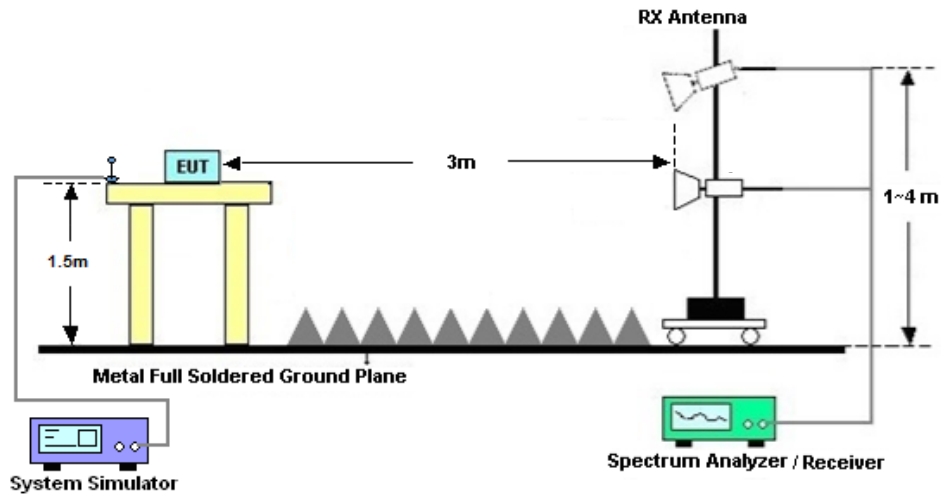

4.3 Test Result of Radiated Test

The low frequency, which started from 9 kHz to 30MHz, was pre-scanned and the result which was 20dB lower than the limit line was not reported.

Please refer to Appendix B.



4.4 Radiated Spurious Emission

4.4.1 Description of Radiated Spurious Emission

The radiated spurious emission was measured by substitution method according to ANSI C63.26. The power of any emission outside of the authorized operating frequency ranges must be attenuated below the transmitter power (P) by a factor of at least $43 + 10 \log (P)$ dB.

The spectrum is scanned from 30 MHz up to a frequency including its 10th harmonic.

4.4.2 Test Procedures

1. The testing follows ANSI C63.26 Section 5.5
2. The EUT was placed on a turntable with 0.8 meter height for frequency below 1GHz and 1.5 meter height for frequency above 1GHz respectively above ground.
3. The EUT was set 3 meters from the receiving antenna mounted on the antenna tower.
4. The table was rotated 360 degrees to determine the position of the highest spurious emission.
5. The height of the receiving antenna is varied between 1m to 4m to search the maximum spurious emission for both horizontal and vertical polarizations.
6. During the measurement, the system simulator parameters were set to force the EUT transmitting at maximum output power.
7. Make the measurement with the spectrum analyzer's RBW = 1MHz, VBW = 3MHz, taking the record of maximum spurious emission.
8. A horn antenna was substituted in place of the EUT and was driven by a signal generator.
9. Tune the output power of signal generator to the same emission level with EUT maximum spurious emission.
10. $EIRP \text{ (dBm)} = S.G. \text{ Power} - Tx \text{ Cable Loss} + Tx \text{ Antenna Gain}$
11. $ERP \text{ (dBm)} = EIRP - 2.15$
12. The RF fundamental frequency should be excluded against the limit line in the operating frequency band.

The limit line is derived from $43 + 10\log(P)$ dB below the transmitter power P(Watts)
= $P(W) - [43 + 10\log(P)]$ (dB)
= $[30 + 10\log(P)]$ (dBm) - $[43 + 10\log(P)]$ (dB)
= -13dBm.



5 List of Measuring Equipment

Instrument	Manufacturer	Model No.	Serial No.	Characteristics	Calibration Date	Test Date	Due Date	Remark
Spectrum Analyzer	R&S	FSV40	101040	10Hz~40GHz	Oct. 11, 2023	Jul. 25, 2024~ Jul. 29, 2024	Oct. 10, 2024	Conducted (TH01-KS)
Power divider	STI	STI08-0055	-	0.5~40GHz	NCR	Jul. 25, 2024~ Jul. 29, 2024	NCR	Conducted (TH01-KS)
Temperature & humidity chamber	Hongzhan	LP-150U	H2014011440	-40~+150°C 20%~95%RH	Jul. 04, 2024	Jul. 25, 2024~ Jul. 29, 2024	Jul. 03, 2025	Conducted (TH01-KS)
EXA Spectrum Analyzer	Keysight	N9010B	MY57471079	10Hz-44G,MAX 30dB	Oct. 11, 2023	Jul. 23, 2024	Oct. 10, 2024	Radiation (03CH04-KS)
Loop Antenna	R&S	HFH2-Z2E	101125	9kHz~30MHz	Sep. 11 2023	Jul. 23, 2024	Sep. 10, 2024	Radiation (03CH04-KS)
Bilog Antenna	TeseQ	CBL6111D	59913	30MHz-1GHz	Aug. 19, 2023	Jul. 23, 2024	Aug. 18, 2024	Radiation (03CH04-KS)
Double Ridge Horn Antenna	ETS-Lindgren	3117	75957	1GHz~18GHz	Oct. 23, 2023	Jul. 23, 2024	Oct. 22, 2024	Radiation (03CH04-KS)
SHF-EHF Horn	Com-power	AH-840	101070	18GHz~40GHz	Jan. 27, 2024	Jul. 23, 2024	Jan. 26, 2025	Radiation (03CH04-KS)
Amplifier	SONOMA	310N	413740	9KHz-1GHz	Jan. 03, 2024	Jul. 23, 2024	Jan. 02, 2025	Radiation (03CH04-KS)
high gain Amplifier	EM	EM01G18G A	060840	1Ghz-18Ghz	Oct. 11, 2023	Jul. 23, 2024	Oct. 10, 2024	Radiation (03CH04-KS)
Amplifier	EM	EM18G40G A	060728	18~40GHz	Jan. 02, 2024	Jul. 23, 2024	Jan. 01, 2025	Radiation (03CH04-KS)
AC Power Source	Chroma	61601	F104090004	N/A	NCR	Jul. 23, 2024	NCR	Radiation (03CH04-KS)
Turn Table	ChamPro	EM 1000-T	060762-T	0~360 degree	NCR	Jul. 23, 2024	NCR	Radiation (03CH04-KS)
Antenna Mast	ChamPro	EM 1000-A	060762-A	1 m~4 m	NCR	Jul. 23, 2024	NCR	Radiation (03CH04-KS)

NCR: No Calibration Required



6 Measurement Uncertainty

The measurement uncertainties shown below were calculated in accordance with the requirements of ANSI 63.26-2015. All the measurement uncertainty value were shown with a coverage K=2 to indicate 95% level of confidence. The measurement data show herein meets or exceeds the CISPR measurement uncertainty values specified in CISPR 16-4-2 and can be compared directly to specified limit to determine compliance.

Uncertainty of Conducted Measurement

Conducted Spurious Emission & Bandedge	±2.26 dB
Occupied Channel Bandwidth	±0.1%
Conducted Power	±0.46 dB
Peak to Average Ratio	±0.46 dB
Frequency Stability	±0.4 Hz

Uncertainty of Radiated Emission Measurement (30 MHz ~ 1000 MHz)

Measuring Uncertainty for a Level of Confidence of 95% (U = 2Uc(y))	2.83 dB
---	---------

Uncertainty of Radiated Emission Measurement (1 GHz ~ 18 GHz)

Measuring Uncertainty for a Level of Confidence of 95% (U = 2Uc(y))	2.83 dB
---	---------

Uncertainty of Radiated Emission Measurement (18 GHz ~ 40 GHz)

Measuring Uncertainty for a Level of Confidence of 95% (U = 2Uc(y))	2.82 dB
---	---------

----- THE END -----



Appendix A. Test Results of Conducted Test

Test Engineer :	Smile Wang	Temperature :	22~23°C
		Relative Humidity :	40~42%



FR1 N2-SCS 15k (Main PA_ANT 1)

Transmitter Conducted Output Power And EIRP, (G_T - L_C)=-0.7dBi

NR Band	SCS	BandWidth	Arfcn	Freq(MHz)	Modulation	RB	Conducted Power(dBm)	EIRP(dBm)	EIRP(W)
2	15	20	372000	1860	DFT-s-OFDM PI/2 BPSK	50@25	22.83	22.13	0.1633
2	15	20	372000	1860	DFT-s-OFDM PI/2 BPSK	1@1	22.72	22.02	0.1592
2	15	20	372000	1860	DFT-s-OFDM PI/2 BPSK	1@104	22.7	22	0.1585
2	15	20	372000	1860	DFT-s-OFDM QPSK	50@25	22.79	22.09	0.1618
2	15	20	372000	1860	DFT-s-OFDM QPSK	1@1	22.56	21.86	0.1535
2	15	20	372000	1860	DFT-s-OFDM QPSK	1@104	22.64	21.94	0.1563
2	15	20	372000	1860	DFT-s-OFDM 16 QAM	50@25	21.76	21.06	0.1276
2	15	20	372000	1860	DFT-s-OFDM 16 QAM	1@1	21.98	21.28	0.1343
2	15	20	372000	1860	DFT-s-OFDM 16 QAM	1@104	21.88	21.18	0.1312
2	15	20	372000	1860	DFT-s-OFDM 64 QAM	50@25	20.28	19.58	0.0908
2	15	20	372000	1860	DFT-s-OFDM 64 QAM	1@1	20.48	19.78	0.0951
2	15	20	372000	1860	DFT-s-OFDM 64 QAM	1@104	20.38	19.68	0.0929
2	15	20	372000	1860	DFT-s-OFDM 256 QAM	50@25	18.31	17.61	0.0577
2	15	20	372000	1860	DFT-s-OFDM 256 QAM	1@1	18.22	17.52	0.0565
2	15	20	372000	1860	DFT-s-OFDM 256 QAM	1@104	18.22	17.52	0.0565
2	15	20	372000	1860	CP-OFDM QPSK	53@26	21.28	20.58	0.1143
2	15	20	372000	1860	CP-OFDM QPSK	1@1	21.11	20.41	0.1099
2	15	20	372000	1860	CP-OFDM QPSK	1@104	21.09	20.39	0.1094
2	15	20	376000	1880	DFT-s-OFDM PI/2 BPSK	50@25	22.78	22.08	0.1614
2	15	20	376000	1880	DFT-s-OFDM PI/2 BPSK	1@1	22.67	21.97	0.1574
2	15	20	376000	1880	DFT-s-OFDM PI/2 BPSK	1@104	22.56	21.86	0.1535
2	15	20	376000	1880	DFT-s-OFDM QPSK	50@25	22.75	22.05	0.1603
2	15	20	376000	1880	DFT-s-OFDM QPSK	1@1	22.62	21.92	0.1556
2	15	20	376000	1880	DFT-s-OFDM QPSK	1@104	22.45	21.75	0.1496
2	15	20	376000	1880	DFT-s-OFDM 16 QAM	50@25	21.75	21.05	0.1274
2	15	20	376000	1880	DFT-s-OFDM 16 QAM	1@1	21.83	21.13	0.1297
2	15	20	376000	1880	DFT-s-OFDM 16 QAM	1@104	21.77	21.07	0.1279
2	15	20	376000	1880	DFT-s-OFDM 64 QAM	50@25	20.25	19.55	0.0902
2	15	20	376000	1880	DFT-s-OFDM 64 QAM	1@1	20.38	19.68	0.0929
2	15	20	376000	1880	DFT-s-OFDM 64 QAM	1@104	20.34	19.64	0.0920
2	15	20	376000	1880	DFT-s-OFDM 256 QAM	50@25	18.27	17.57	0.0571
2	15	20	376000	1880	DFT-s-OFDM 256 QAM	1@1	18.07	17.37	0.0546
2	15	20	376000	1880	DFT-s-OFDM 256 QAM	1@104	17.98	17.28	0.0535
2	15	20	376000	1880	CP-OFDM QPSK	53@26	21.25	20.55	0.1135
2	15	20	376000	1880	CP-OFDM QPSK	1@1	21.09	20.39	0.1094
2	15	20	376000	1880	CP-OFDM QPSK	1@104	20.92	20.22	0.1052
2	15	20	380000	1900	DFT-s-OFDM PI/2 BPSK	50@25	22.62	21.92	0.1556
2	15	20	380000	1900	DFT-s-OFDM PI/2 BPSK	1@1	22.58	21.88	0.1542
2	15	20	380000	1900	DFT-s-OFDM PI/2 BPSK	1@104	22.64	21.94	0.1563
2	15	20	380000	1900	DFT-s-OFDM QPSK	50@25	22.59	21.89	0.1545



2	15	20	380000	1900	DFT-s-OFDM QPSK	1@1	22.54	21.84	0.1528
2	15	20	380000	1900	DFT-s-OFDM QPSK	1@104	22.59	21.89	0.1545
2	15	20	380000	1900	DFT-s-OFDM 16 QAM	50@25	21.62	20.92	0.1236
2	15	20	380000	1900	DFT-s-OFDM 16 QAM	1@1	21.44	20.74	0.1186
2	15	20	380000	1900	DFT-s-OFDM 16 QAM	1@104	21.51	20.81	0.1205
2	15	20	380000	1900	DFT-s-OFDM 64 QAM	50@25	20.11	19.41	0.0873
2	15	20	380000	1900	DFT-s-OFDM 64 QAM	1@1	20.57	19.87	0.0971
2	15	20	380000	1900	DFT-s-OFDM 64 QAM	1@104	20.62	19.92	0.0982
2	15	20	380000	1900	DFT-s-OFDM 256 QAM	50@25	18.14	17.44	0.0555
2	15	20	380000	1900	DFT-s-OFDM 256 QAM	1@1	17.99	17.29	0.0536
2	15	20	380000	1900	DFT-s-OFDM 256 QAM	1@104	18.26	17.56	0.0570
2	15	20	380000	1900	CP-OFDM QPSK	53@26	21.1	20.4	0.1096
2	15	20	380000	1900	CP-OFDM QPSK	1@1	21.14	20.44	0.1107
2	15	20	380000	1900	CP-OFDM QPSK	1@104	21.19	20.49	0.1119
2	15	5	370500	1852.5	DFT-s-OFDM PI/2 BPSK	1@1	22.78	22.08	0.1614
2	15	5	370500	1852.5	DFT-s-OFDM QPSK	1@1	22.77	22.07	0.1611
2	15	5	370500	1852.5	DFT-s-OFDM 16 QAM	1@1	21.64	20.94	0.1242
2	15	5	376000	1880	DFT-s-OFDM PI/2 BPSK	1@1	22.69	21.99	0.1581
2	15	5	376000	1880	DFT-s-OFDM QPSK	1@1	22.63	21.93	0.1560
2	15	5	376000	1880	DFT-s-OFDM 16 QAM	1@1	21.86	21.16	0.1306
2	15	5	381500	1907.5	DFT-s-OFDM PI/2 BPSK	1@1	22.53	21.83	0.1524
2	15	5	381500	1907.5	DFT-s-OFDM QPSK	1@1	22.42	21.72	0.1486
2	15	5	381500	1907.5	DFT-s-OFDM 16 QAM	1@1	21.79	21.09	0.1285
2	15	10	371000	1855	DFT-s-OFDM PI/2 BPSK	1@1	22.8	22.1	0.1622
2	15	10	371000	1855	DFT-s-OFDM QPSK	1@1	22.64	21.94	0.1563
2	15	10	371000	1855	DFT-s-OFDM 16 QAM	1@1	22.09	21.39	0.1377
2	15	10	376000	1880	DFT-s-OFDM PI/2 BPSK	1@1	22.79	22.09	0.1618
2	15	10	376000	1880	DFT-s-OFDM QPSK	1@1	22.76	22.06	0.1607
2	15	10	376000	1880	DFT-s-OFDM 16 QAM	1@1	21.61	20.91	0.1233
2	15	10	381000	1905	DFT-s-OFDM PI/2 BPSK	1@1	22.48	21.78	0.1507
2	15	10	381000	1905	DFT-s-OFDM QPSK	1@1	22.43	21.73	0.1489
2	15	10	381000	1905	DFT-s-OFDM 16 QAM	1@1	21.66	20.96	0.1247
2	15	15	371500	1857.5	DFT-s-OFDM PI/2 BPSK	1@1	22.77	22.07	0.1611
2	15	15	371500	1857.5	DFT-s-OFDM QPSK	1@1	22.61	21.91	0.1552
2	15	15	371500	1857.5	DFT-s-OFDM 16 QAM	1@1	21.99	21.29	0.1346
2	15	15	376000	1880	DFT-s-OFDM PI/2 BPSK	1@1	22.7	22	0.1585
2	15	15	376000	1880	DFT-s-OFDM QPSK	1@1	22.66	21.96	0.1570
2	15	15	376000	1880	DFT-s-OFDM 16 QAM	1@1	21.9	21.2	0.1318
2	15	15	380500	1902.5	DFT-s-OFDM PI/2 BPSK	1@1	22.59	21.89	0.1545
2	15	15	380500	1902.5	DFT-s-OFDM QPSK	1@1	22.49	21.79	0.1510
2	15	15	380500	1902.5	DFT-s-OFDM 16 QAM	1@1	21.77	21.07	0.1279



Frequency Stability

NR Band	SCS (kHz)	Bandwidth (MHz)	Arfcn	Freq (MHz)	Modulation	RB	Deviation (ppm)	Verdict	Environment
2	15	20	376000	1880.0	DFT-s-OFDM QPSK	100@0	0.0021	PASS	NV
2	15	20	376000	1880.0	DFT-s-OFDM QPSK	100@0	-0.0029	PASS	LV
2	15	20	376000	1880.0	DFT-s-OFDM QPSK	100@0	0.0034	PASS	HV
2	15	20	376000	1880.0	DFT-s-OFDM QPSK	100@0	0.0071	PASS	-30°C
2	15	20	376000	1880.0	DFT-s-OFDM QPSK	100@0	-0.0026	PASS	-20°C
2	15	20	376000	1880.0	DFT-s-OFDM QPSK	100@0	0.0034	PASS	-10°C
2	15	20	376000	1880.0	DFT-s-OFDM QPSK	100@0	0.0021	PASS	0°C
2	15	20	376000	1880.0	DFT-s-OFDM QPSK	100@0	-0.0032	PASS	10°C
2	15	20	376000	1880.0	DFT-s-OFDM QPSK	100@0	-0.0019	PASS	20°C
2	15	20	376000	1880.0	DFT-s-OFDM QPSK	100@0	-0.0057	PASS	30°C
2	15	20	376000	1880.0	DFT-s-OFDM QPSK	100@0	-0.0017	PASS	40°C
2	15	20	376000	1880.0	DFT-s-OFDM QPSK	100@0	0.0044	PASS	50°C



Peak to Average Ratio

NR Band	SCS (kHz)	Bandwidth (MHz)	Arfcn	Freq (MHz)	Modulation	RB	Result (dB)	Limit (dB)	Verdict
2	15	20	376000	1880.0	DFT-s-OFDM PI/2 BPSK	100@0	4.05	13	PASS
2	15	20	376000	1880.0	DFT-s-OFDM PI/2 BPSK	1@0	3.73	13	PASS
2	15	20	376000	1880.0	DFT-s-OFDM QPSK	100@0	5.15	13	PASS
2	15	20	376000	1880.0	DFT-s-OFDM QPSK	1@0	4.39	13	PASS

N2(20M)_DFT-s-OFDM_PI_2-BPSK_Outer_Full_Mid_CH



N2(20M)_DFT-s-OFDM_PI_2-BPSK_Edge_1RB_Left_Mid_CH



N2(20M)_DFT-s-OFDM_QPSK_Outer_Full_Mid_CH



N2(20M)_DFT-s-OFDM_QPSK_Edge_1RB_Left_Mid_CH





Occupied Bandwidth

NR Band	SCS (kHz)	Bandwidth (MHz)	Arfcn	Freq (MHz)	Modulation	RB	OBW (MHz)	26dB BW (MHz)
2	15	5	376000	1880.0	CP-OFDM QPSK	25@0	4.4612	4.822
2	15	5	376000	1880.0	CP-OFDM 16 QAM	25@0	4.4625	4.795
2	15	5	376000	1880.0	CP-OFDM 64 QAM	25@0	4.4768	4.815
2	15	5	376000	1880.0	CP-OFDM 256 QAM	25@0	4.4681	4.837
2	15	10	376000	1880.0	CP-OFDM QPSK	52@0	9.258	9.743
2	15	10	376000	1880.0	CP-OFDM 16 QAM	52@0	9.2683	9.691
2	15	10	376000	1880.0	CP-OFDM 64 QAM	52@0	9.284	9.715
2	15	10	376000	1880.0	CP-OFDM 256 QAM	52@0	9.2696	9.741
2	15	15	376000	1880.0	CP-OFDM QPSK	79@0	14.07	14.62
2	15	15	376000	1880.0	CP-OFDM 16 QAM	79@0	14.086	14.69
2	15	15	376000	1880.0	CP-OFDM 64 QAM	79@0	14.062	14.72
2	15	15	376000	1880.0	CP-OFDM 256 QAM	79@0	14.088	14.66
2	15	20	376000	1880.0	CP-OFDM QPSK	106@0	18.864	19.67
2	15	20	376000	1880.0	CP-OFDM 16 QAM	106@0	18.889	19.6
2	15	20	376000	1880.0	CP-OFDM 64 QAM	106@0	18.855	19.55
2	15	20	376000	1880.0	CP-OFDM 256 QAM	106@0	18.915	19.61



N2(5M)_CP-OFDM_QPSK_Outer_Full_Mid_CH

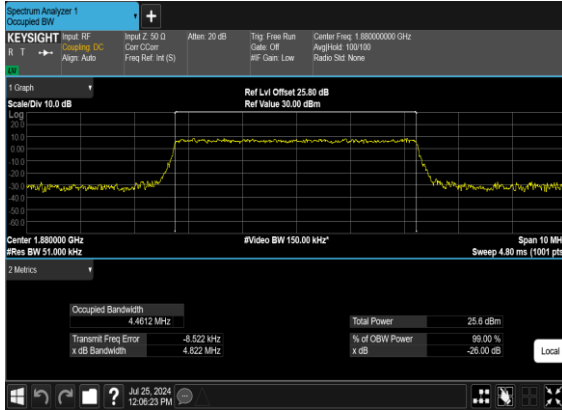

N2(5M)_CP-OFDM_16 QAM_Outer_Full_Mid_CH

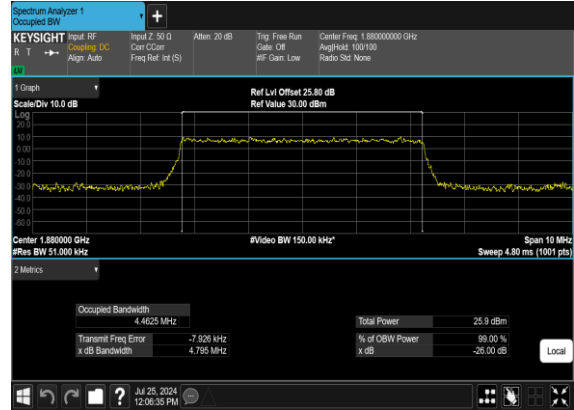

N2(5M)_CP-OFDM_64 QAM_Outer_Full_Mid_CH

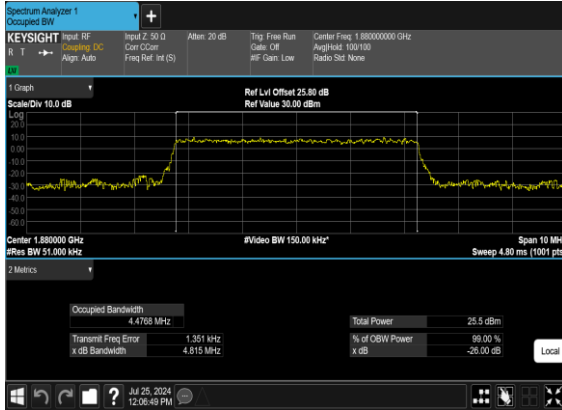

N2(5M)_CP-OFDM_256 QAM_Outer_Full_Mid_CH

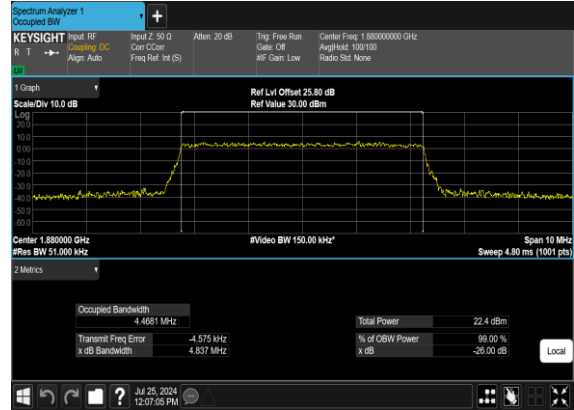

N2(10M)_CP-OFDM_QPSK_Outer_Full_Mid_CH

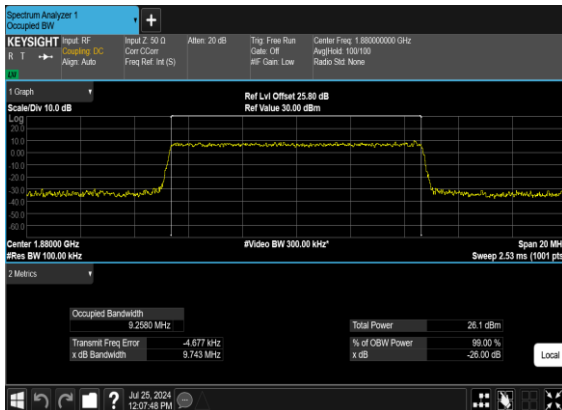

N2(10M)_CP-OFDM_16 QAM_Outer_Full_Mid_CH

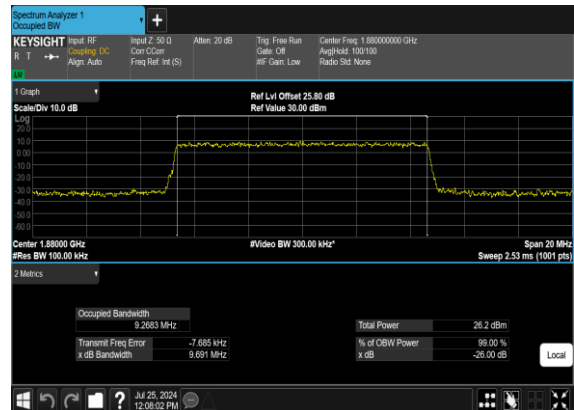



N2(10M)_CP-OFDM_64
QAM_Outer_Full_Mid_CH

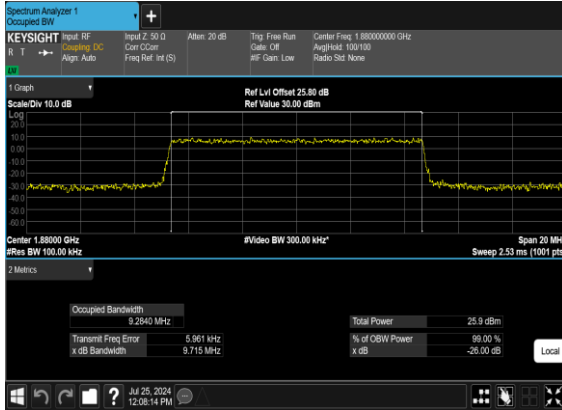

N2(10M)_CP-OFDM_256
QAM_Outer_Full_Mid_CH

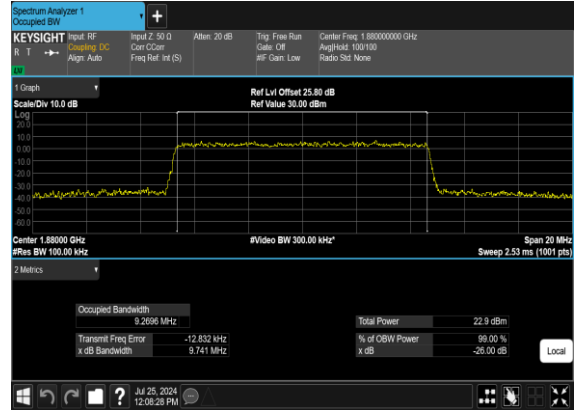

N2(15M)_CP-
OFDM_QPSK_Outer_Full_Mid_CH

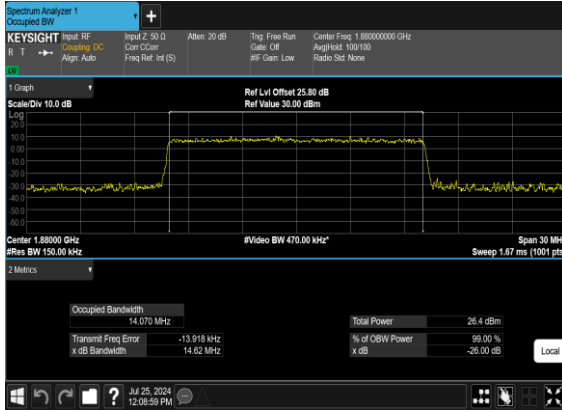

N2(15M)_CP-OFDM_16
QAM_Outer_Full_Mid_CH

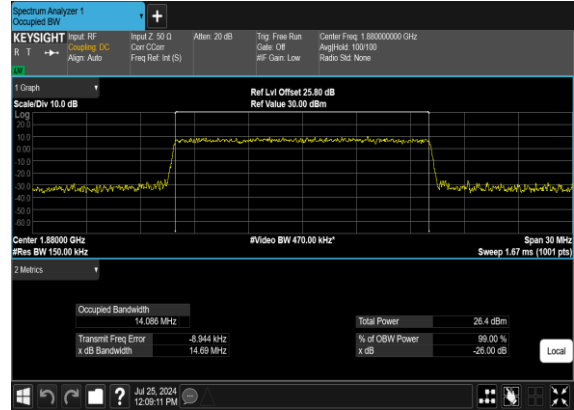

N2(15M)_CP-OFDM_64
QAM_Outer_Full_Mid_CH

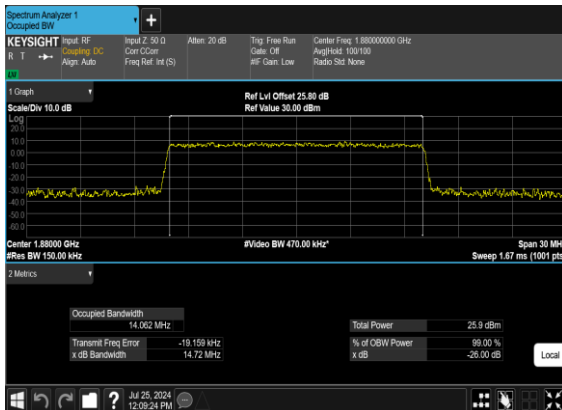

N2(15M)_CP-OFDM_256
QAM_Outer_Full_Mid_CH

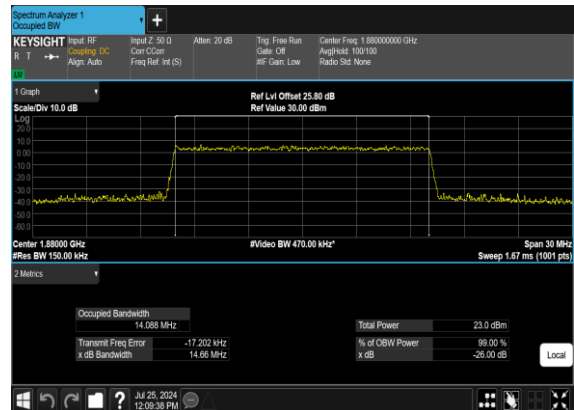



N2(20M)_CP-OFDM_QPSK_Outer_Full_Mid_CH

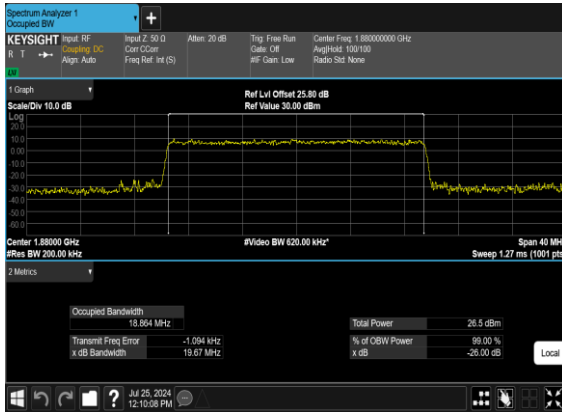

N2(20M)_CP-OFDM_16QAM_Outer_Full_Mid_CH

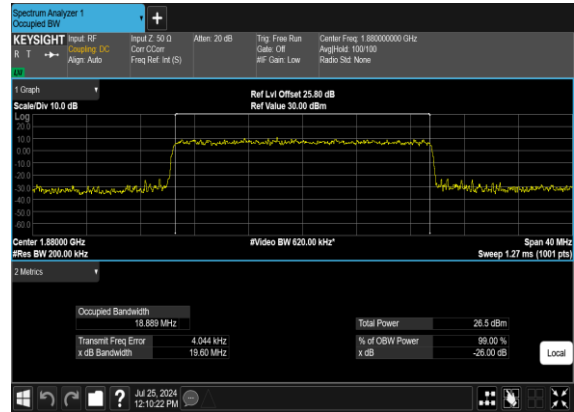

N2(20M)_CP-OFDM_64QAM_Outer_Full_Mid_CH

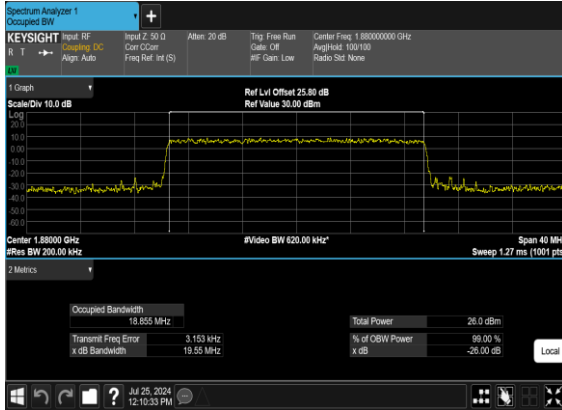

N2(20M)_CP-OFDM_256QAM_Outer_Full_Mid_CH

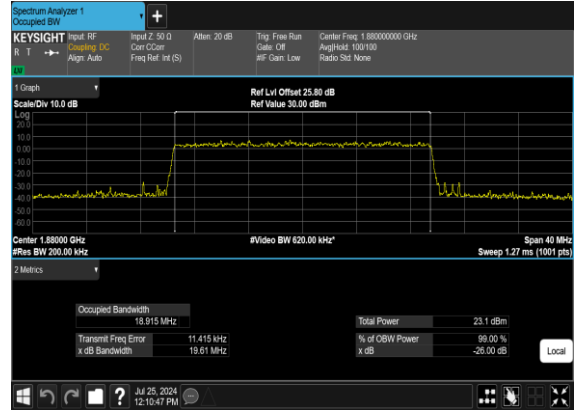



Conducted Spurious Emissions

NR Band	SCS (kHz)	Bandwidth (MHz)	Arfcn	Freq (MHz)	Modulation	RB	Result	Verdict
2	15	5	370500	1852.5	DFT-s-OFDM BPSK	1@0	see graph	---
2	15	5	370500	1852.5	DFT-s-OFDM BPSK	1@0	see graph	PASS
2	15	5	370500	1852.5	DFT-s-OFDM QPSK	1@0	see graph	---
2	15	5	370500	1852.5	DFT-s-OFDM QPSK	1@0	see graph	PASS
2	15	5	376000	1880.0	DFT-s-OFDM BPSK	1@0	see graph	---
2	15	5	376000	1880.0	DFT-s-OFDM BPSK	1@0	see graph	PASS
2	15	5	376000	1880.0	DFT-s-OFDM QPSK	1@0	see graph	---
2	15	5	376000	1880.0	DFT-s-OFDM QPSK	1@0	see graph	PASS
2	15	5	381500	1907.5	DFT-s-OFDM BPSK	1@0	see graph	---
2	15	5	381500	1907.5	DFT-s-OFDM BPSK	1@0	see graph	PASS
2	15	5	381500	1907.5	DFT-s-OFDM QPSK	1@0	see graph	---
2	15	5	381500	1907.5	DFT-s-OFDM QPSK	1@0	see graph	PASS
2	15	15	371500	1857.5	DFT-s-OFDM BPSK	1@0	see graph	---
2	15	15	371500	1857.5	DFT-s-OFDM BPSK	1@0	see graph	PASS
2	15	15	371500	1857.5	DFT-s-OFDM QPSK	1@0	see graph	---
2	15	15	371500	1857.5	DFT-s-OFDM QPSK	1@0	see graph	PASS
2	15	15	376000	1880.0	DFT-s-OFDM BPSK	1@0	see graph	---
2	15	15	376000	1880.0	DFT-s-OFDM BPSK	1@0	see graph	PASS
2	15	15	376000	1880.0	DFT-s-OFDM QPSK	1@0	see graph	---
2	15	15	376000	1880.0	DFT-s-OFDM QPSK	1@0	see graph	PASS
2	15	15	380500	1902.5	DFT-s-OFDM BPSK	1@0	see graph	---
2	15	15	380500	1902.5	DFT-s-OFDM BPSK	1@0	see graph	PASS
2	15	15	380500	1902.5	DFT-s-OFDM QPSK	1@0	see graph	---
2	15	15	380500	1902.5	DFT-s-OFDM QPSK	1@0	see graph	PASS



2	15	20	372000	1860.0	DFT-s-OFDM BPSK	1@0	see graph	---
2	15	20	372000	1860.0	DFT-s-OFDM BPSK	1@0	see graph	PASS
2	15	20	372000	1860.0	DFT-s-OFDM QPSK	1@0	see graph	---
2	15	20	372000	1860.0	DFT-s-OFDM QPSK	1@0	see graph	PASS
2	15	20	376000	1880.0	DFT-s-OFDM BPSK	1@0	see graph	---
2	15	20	376000	1880.0	DFT-s-OFDM BPSK	1@0	see graph	PASS
2	15	20	376000	1880.0	DFT-s-OFDM QPSK	1@0	see graph	---
2	15	20	376000	1880.0	DFT-s-OFDM QPSK	1@0	see graph	PASS
2	15	20	380000	1900.0	DFT-s-OFDM BPSK	1@0	see graph	---
2	15	20	380000	1900.0	DFT-s-OFDM BPSK	1@0	see graph	PASS
2	15	20	380000	1900.0	DFT-s-OFDM QPSK	1@0	see graph	---
2	15	20	380000	1900.0	DFT-s-OFDM QPSK	1@0	see graph	PASS



N2(5M)_DFT-s-OFDM_BPSK_Edge_1RB_Left_Low_CH

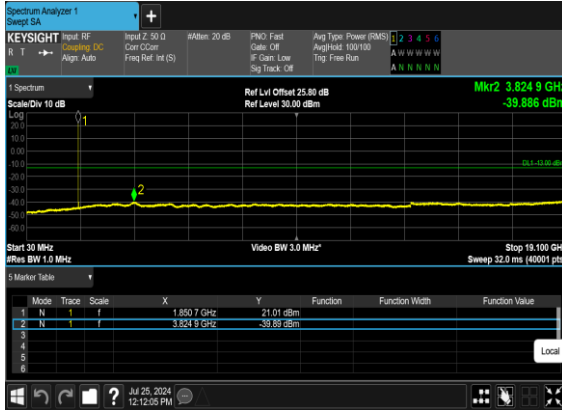

N2(5M)_DFT-s-OFDM_QPSK_Edge_1RB_Left_Low_CH

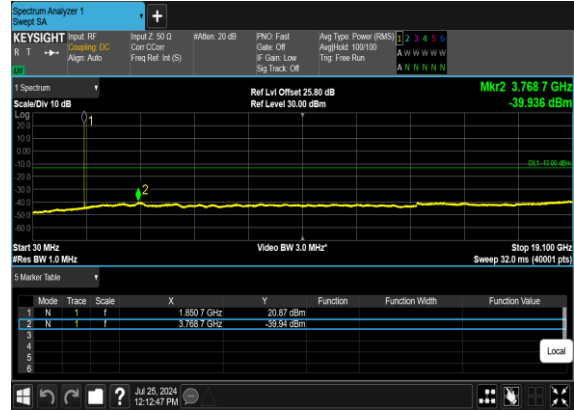

N2(5M)_DFT-s-OFDM_BPSK_Edge_1RB_Left_Mid_CH



N2(5M)_DFT-s-OFDM_QPSK_Edge_1RB_Left_Mid_CH

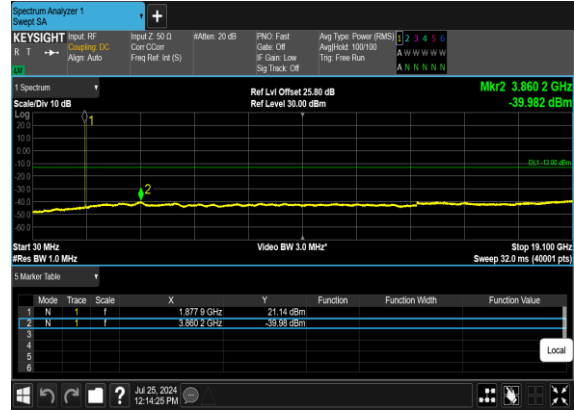

N2(5M)_DFT-s-OFDM_BPSK_Edge_1RB_Left_High_CH

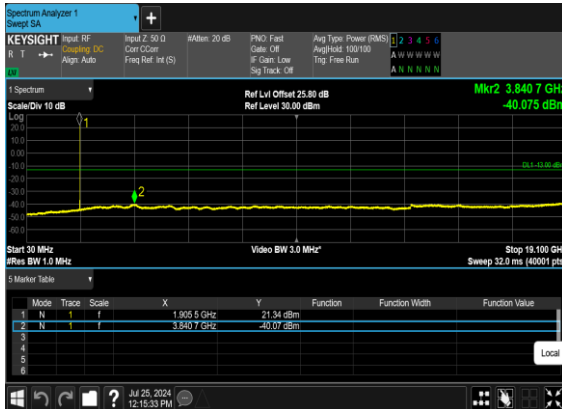

N2(5M)_DFT-s-OFDM_QPSK_Edge_1RB_Left_High_CH

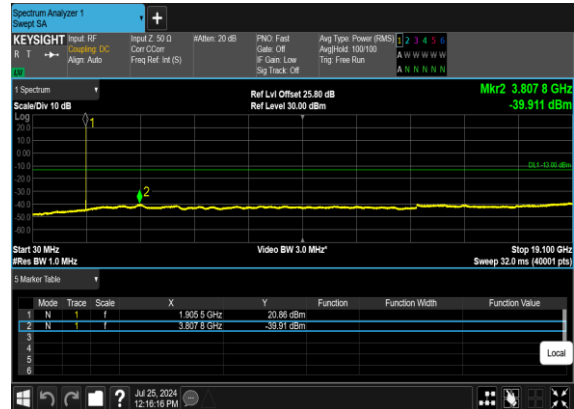



N2(15M)_DFT-s-OFDM_BPSK_Edge_1RB_Left_Low_CH

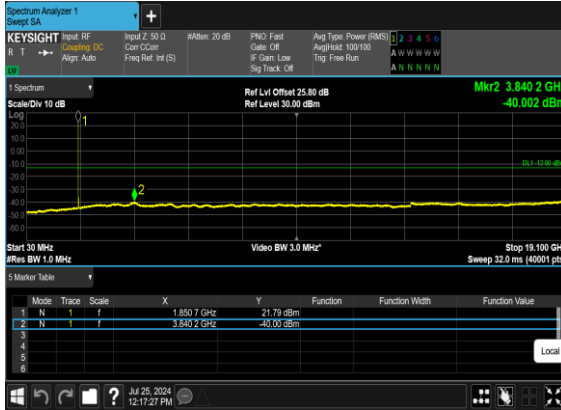

N2(15M)_DFT-s-OFDM_QPSK_Edge_1RB_Left_Low_CH

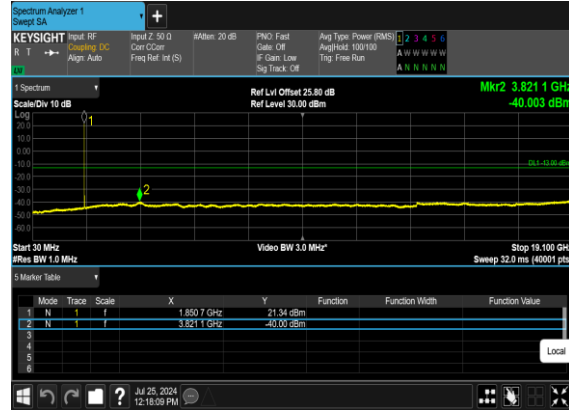

N2(15M)_DFT-s-OFDM_BPSK_Edge_1RB_Left_Mid_CH

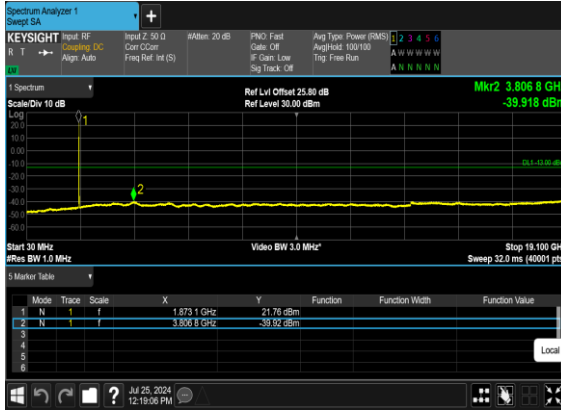

N2(15M)_DFT-s-OFDM_QPSK_Edge_1RB_Left_Mid_CH

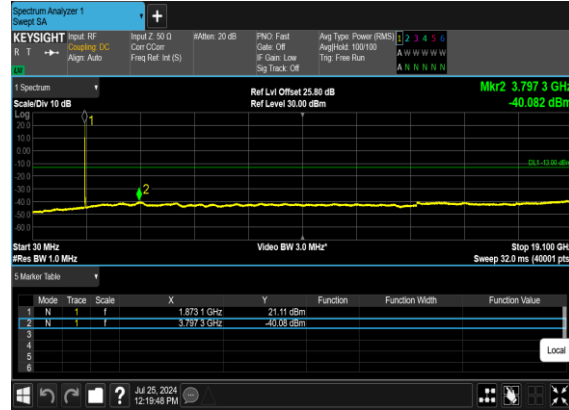

N2(15M)_DFT-s-OFDM_BPSK_Edge_1RB_Left_High_CH

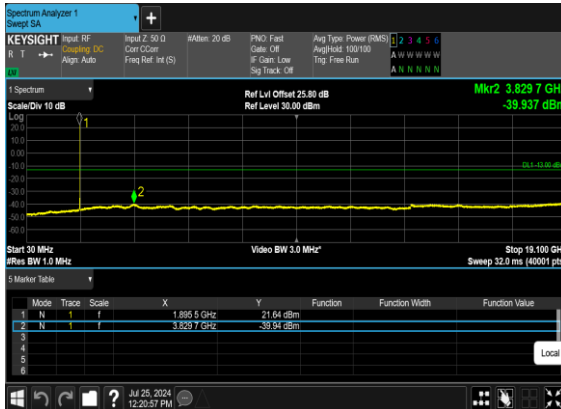

N2(15M)_DFT-s-OFDM_QPSK_Edge_1RB_Left_High_CH

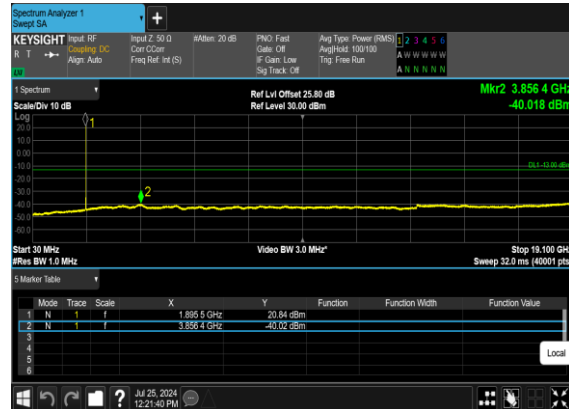



N2(20M)_DFT-s-OFDM_BPSK_Edge_1RB_Left_Low_CH

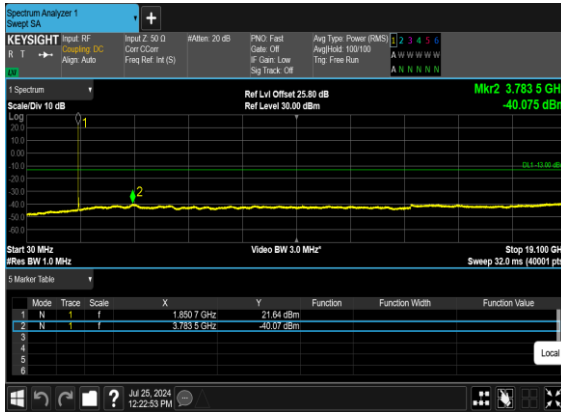

N2(20M)_DFT-s-OFDM_QPSK_Edge_1RB_Left_Low_CH

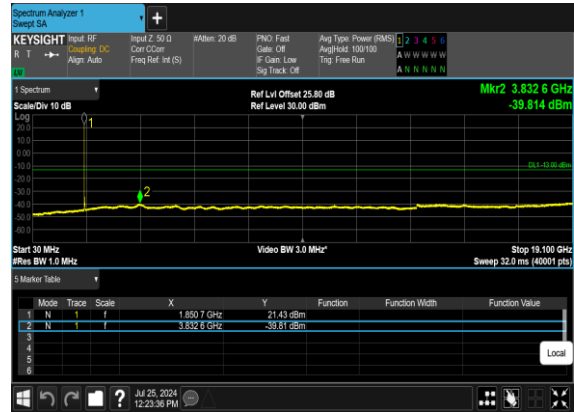

N2(20M)_DFT-s-OFDM_BPSK_Edge_1RB_Left_Mid_CH

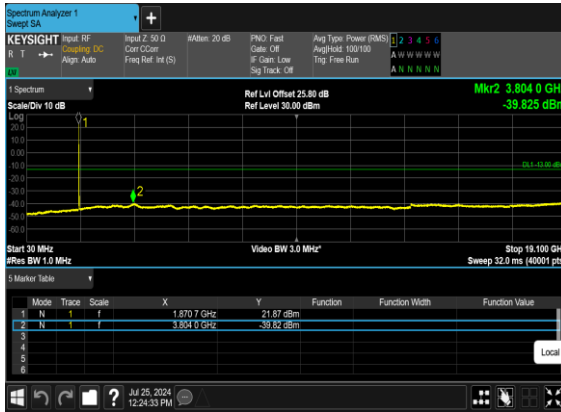

N2(20M)_DFT-s-OFDM_QPSK_Edge_1RB_Left_Mid_CH

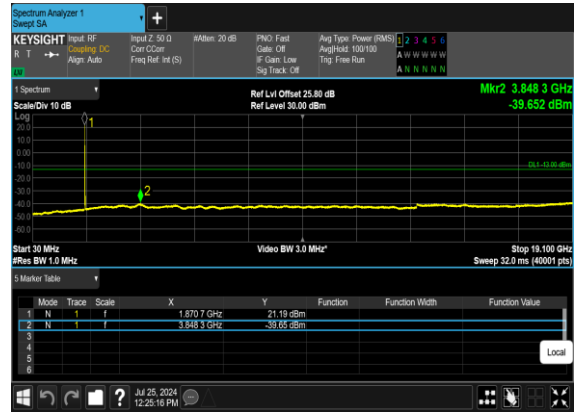

N2(20M)_DFT-s-OFDM_BPSK_Edge_1RB_Left_High_CH

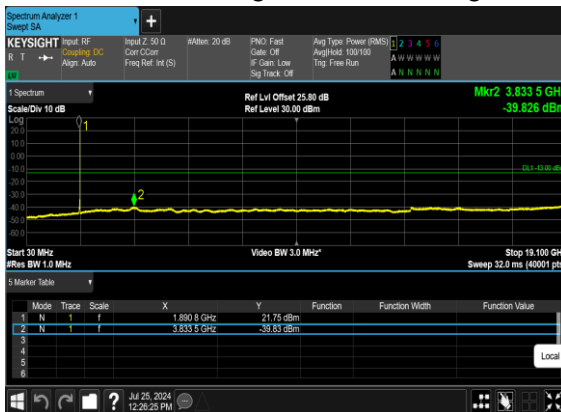

N2(20M)_DFT-s-OFDM_QPSK_Edge_1RB_Left_High_CH

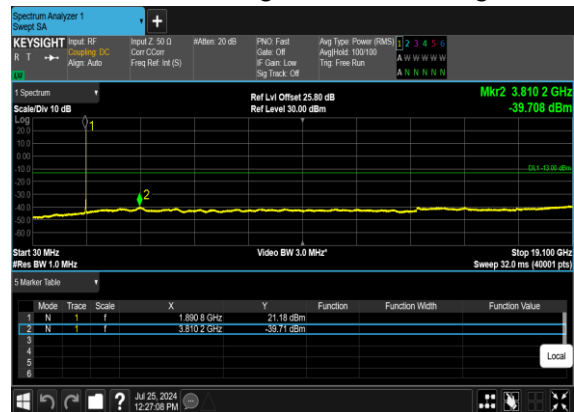



Conducted Band Edge

NR Band	SCS (kHz)	Bandwidth (MHz)	Arfcn	Freq (MHz)	Modulation	RB	Result	Verdict
2	15	5	370500	1852.5	DFT-s-OFDM BPSK	1@0	see graph	PASS
2	15	5	370500	1852.5	DFT-s-OFDM QPSK	1@0	see graph	PASS
2	15	5	370500	1852.5	DFT-s-OFDM BPSK	25@0	see graph	PASS
2	15	5	370500	1852.5	DFT-s-OFDM QPSK	25@0	see graph	PASS
2	15	5	381500	1907.5	DFT-s-OFDM BPSK	1@24	see graph	PASS
2	15	5	381500	1907.5	DFT-s-OFDM QPSK	1@24	see graph	PASS
2	15	5	381500	1907.5	DFT-s-OFDM BPSK	25@0	see graph	PASS
2	15	5	381500	1907.5	DFT-s-OFDM QPSK	25@0	see graph	PASS
2	15	15	371500	1857.5	DFT-s-OFDM BPSK	1@0	see graph	PASS
2	15	15	371500	1857.5	DFT-s-OFDM QPSK	1@0	see graph	PASS
2	15	15	371500	1857.5	DFT-s-OFDM BPSK	75@0	see graph	PASS
2	15	15	371500	1857.5	DFT-s-OFDM QPSK	75@0	see graph	PASS
2	15	15	380500	1902.5	DFT-s-OFDM BPSK	1@78	see graph	PASS
2	15	15	380500	1902.5	DFT-s-OFDM QPSK	1@78	see graph	PASS
2	15	15	380500	1902.5	DFT-s-OFDM BPSK	75@0	see graph	PASS
2	15	15	380500	1902.5	DFT-s-OFDM QPSK	75@0	see graph	PASS
2	15	20	372000	1860.0	DFT-s-OFDM BPSK	1@0	see graph	PASS
2	15	20	372000	1860.0	DFT-s-OFDM QPSK	1@0	see graph	PASS
2	15	20	372000	1860.0	DFT-s-OFDM BPSK	100@0	see graph	PASS
2	15	20	372000	1860.0	DFT-s-OFDM QPSK	100@0	see graph	PASS
2	15	20	380000	1900.0	DFT-s-OFDM BPSK	1@105	see graph	PASS
2	15	20	380000	1900.0	DFT-s-OFDM QPSK	1@105	see graph	PASS
2	15	20	380000	1900.0	DFT-s-OFDM BPSK	100@0	see graph	PASS
2	15	20	380000	1900.0	DFT-s-OFDM QPSK	100@0	see graph	PASS



N2(5M)_DFT-s-OFDM_BPSK_Edge_1RB_Left_Low_CH

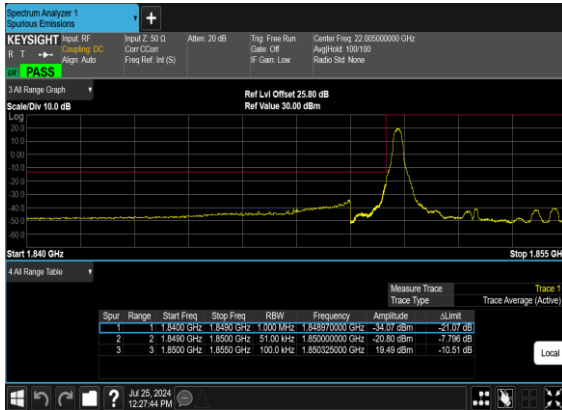

N2(5M)_DFT-s-OFDM_QPSK_Edge_1RB_Left_Low_CH

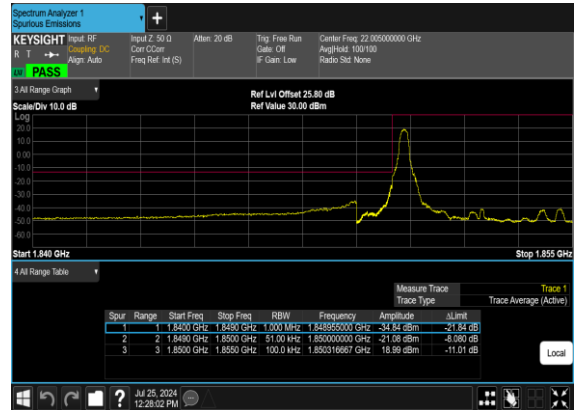

N2(5M)_DFT-s-OFDM_BPSK_Outer_Full_Low_CH

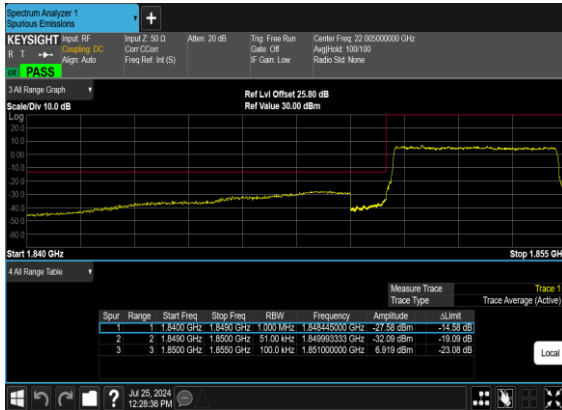

N2(5M)_DFT-s-OFDM_QPSK_Outer_Full_Low_CH

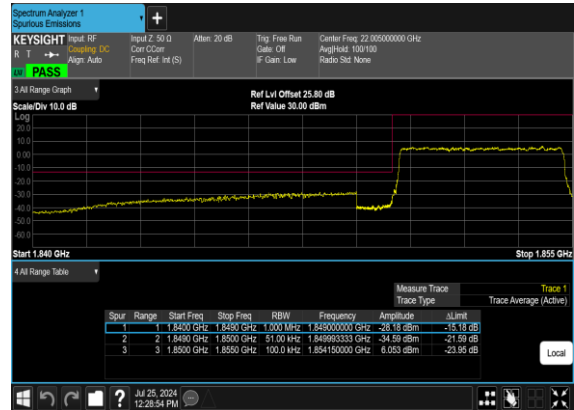

N2(5M)_DFT-s-OFDM_BPSK_Edge_1RB_Right_High_CH

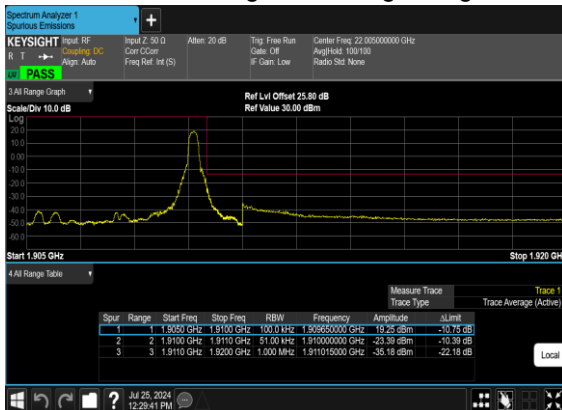

N2(5M)_DFT-s-OFDM_QPSK_Edge_1RB_Right_High_CH

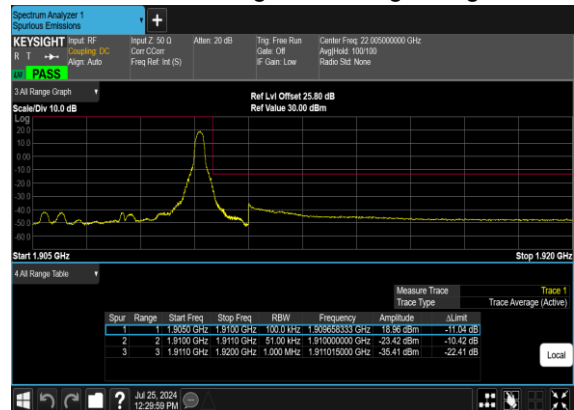



N2(5M)_DFT-s-OFDM_BPSK_Outer_Full_High_CH

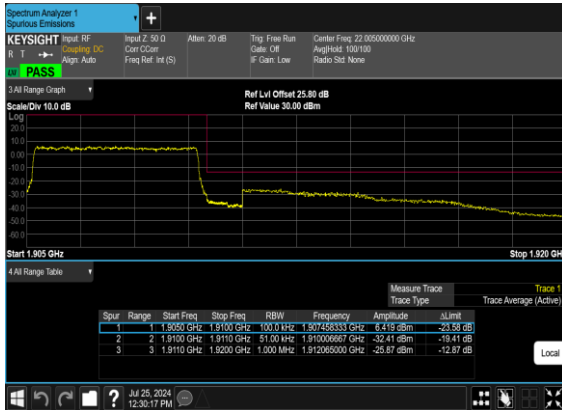

N2(5M)_DFT-s-OFDM_QPSK_Outer_Full_High_CH

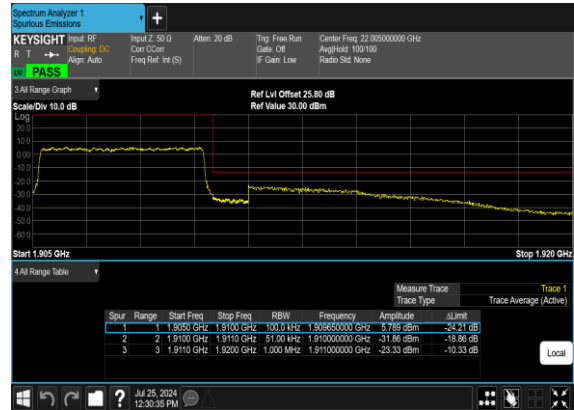

N2(15M)_DFT-s-OFDM_BPSK_Edge_1RB_Left_Low_CH

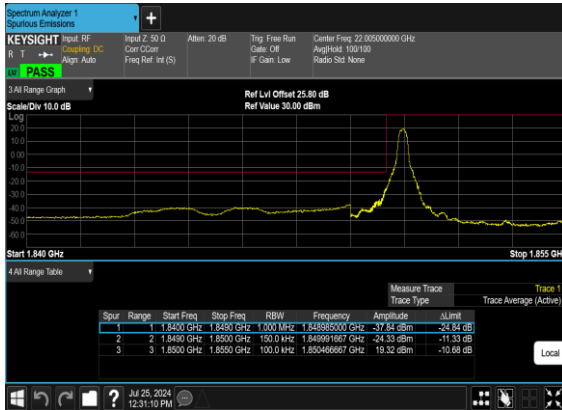

N2(15M)_DFT-s-OFDM_QPSK_Edge_1RB_Left_Low_CH

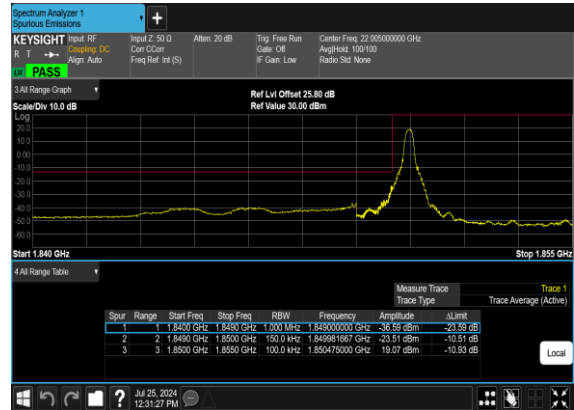

N2(15M)_DFT-s-OFDM_BPSK_Outer_Full_Low_CH

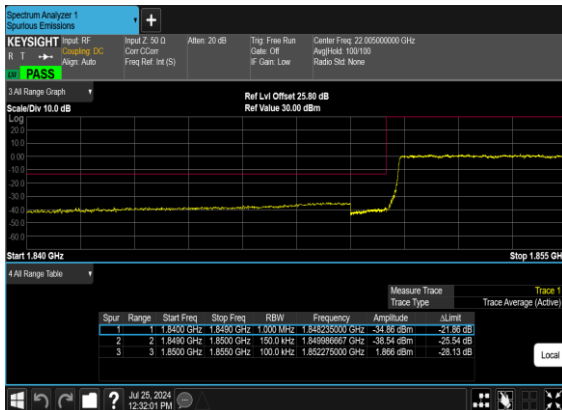

N2(15M)_DFT-s-OFDM_QPSK_Outer_Full_Low_CH

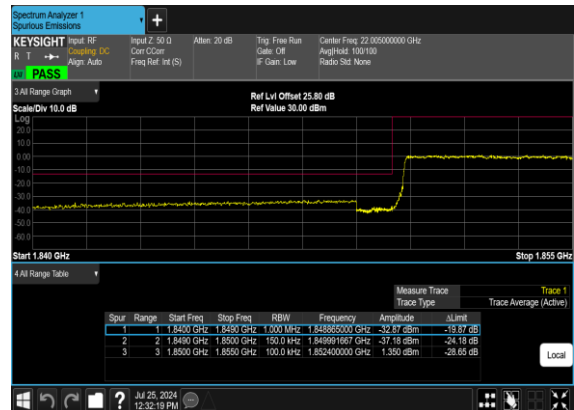



N2(15M)_DFT-s-OFDM_BPSK_Edge_1RB_Right_High_CH

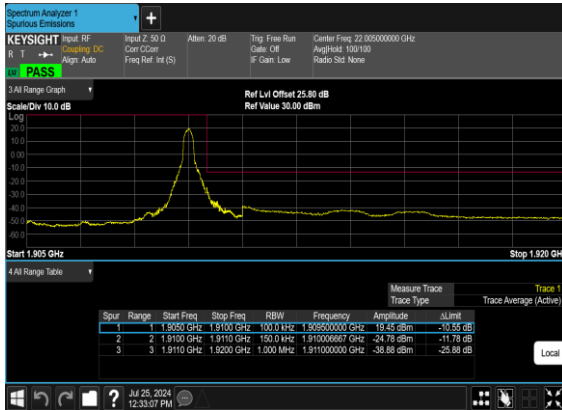

N2(15M)_DFT-s-OFDM_QPSK_Edge_1RB_Right_High_CH

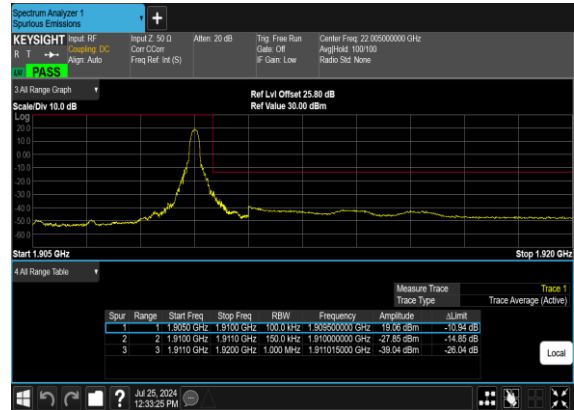

N2(15M)_DFT-s-OFDM_BPSK_Outer_Full_High_CH



N2(15M)_DFT-s-OFDM_QPSK_Outer_Full_High_CH

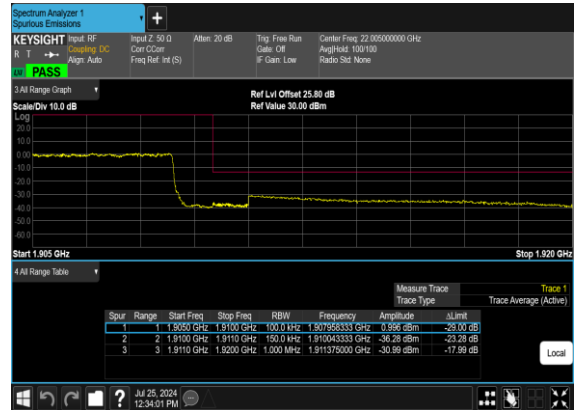

N2(20M)_DFT-s-OFDM_BPSK_Edge_1RB_Left_Low_CH

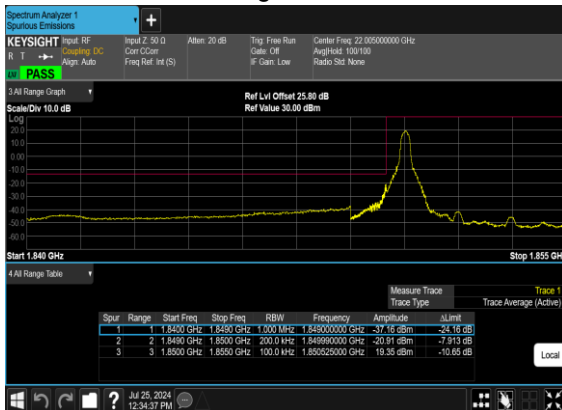

N2(20M)_DFT-s-OFDM_QPSK_Edge_1RB_Left_Low_CH

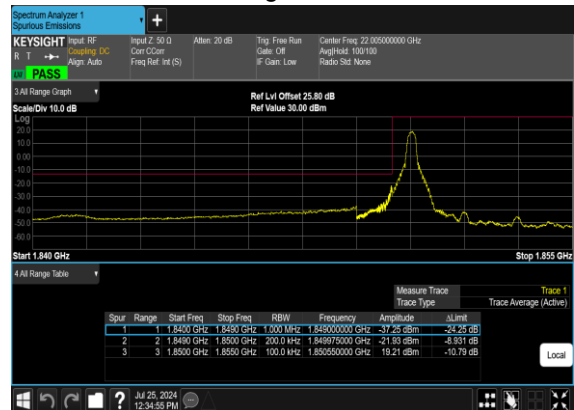



N2(20M)_DFT-s-OFDM_BPSK_Outer_Full_Low_CH

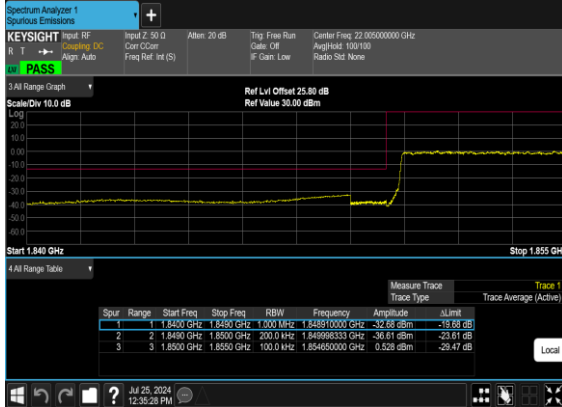

N2(20M)_DFT-s-OFDM_QPSK_Outer_Full_Low_CH

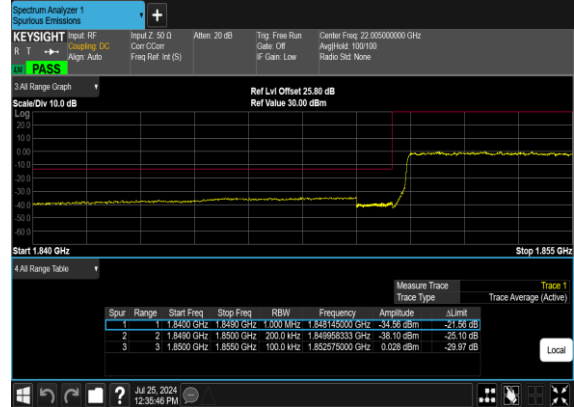

N2(20M)_DFT-s-OFDM_BPSK_Edge_1RB_Right_High_CH

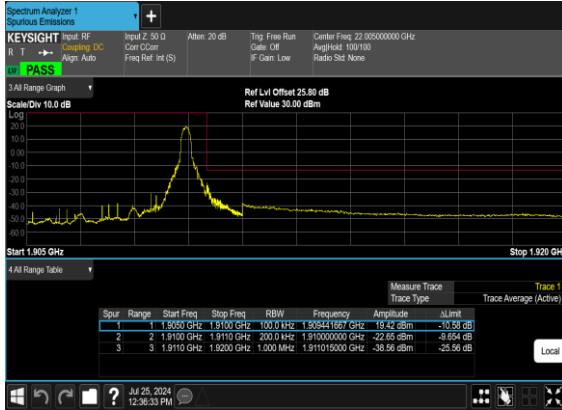

N2(20M)_DFT-s-OFDM_QPSK_Edge_1RB_Right_High_CH

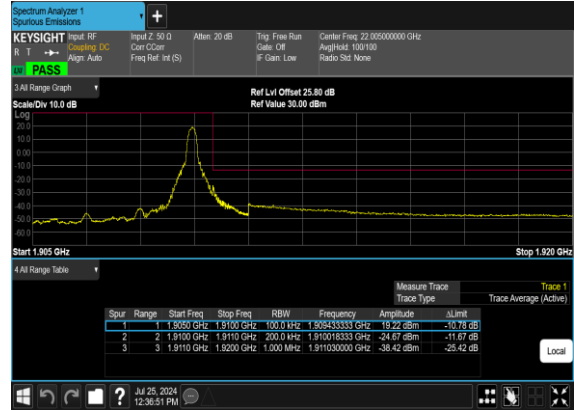

N2(20M)_DFT-s-OFDM_BPSK_Outer_Full_High_CH

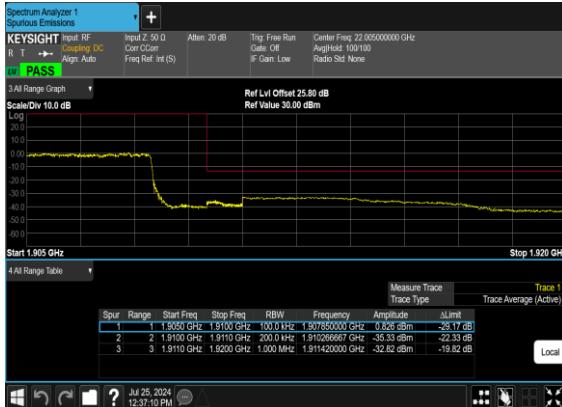

N2(20M)_DFT-s-OFDM_QPSK_Outer_Full_High_CH

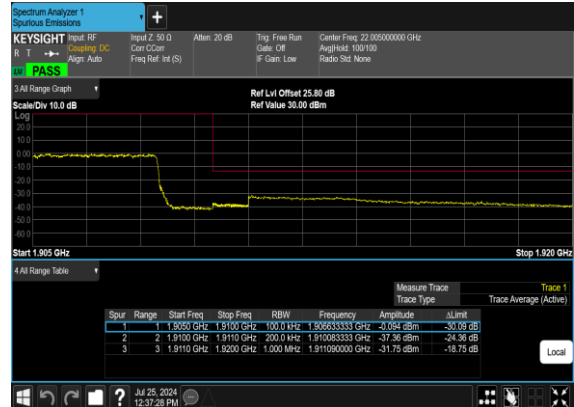



FR1 N2-SCS 15k (Other PA_ANT 2)

Transmitter Conducted Output Power And EIRP, (G_T - L_C)=-3.8dBi

BW [MHz]	Modulation	RB Size	RB Offset	Power Low	Power Middle	Power High	Gain	EIRP	EIRP	EIRP
				Ch. / Freq.	Ch. / Freq.	Ch. / Freq.		L	M	H
Channel				372000	376000	380000				
Frequency (MHz)				1860	1880	1900				
20	PI/2 BPSK	1	1	22.96	22.91	22.92	-3.8	0.0824	0.0815	0.0817
20	QPSK	1	1	22.93	22.83	22.76	-3.8	0.0818	0.0800	0.0787
20	QPSK	1	53	23.02	22.84	22.94	-3.8	0.0836	0.0802	0.0820
20	QPSK	1	104	22.98	22.92	22.85	-3.8	0.0828	0.0817	0.0804
20	QPSK	50	0	22.06	22.08	22.12	-3.8	0.0670	0.0673	0.0679
20	QPSK	50	28	22.83	22.79	22.86	-3.8	0.0800	0.0793	0.0805
20	QPSK	50	56	22.13	22.06	22.06	-3.8	0.0681	0.0670	0.0670
20	QPSK	100	0	22.09	22.05	22.04	-3.8	0.0675	0.0668	0.0667
20	16QAM	1	1	21.96	21.92	21.86	-3.8	0.0655	0.0649	0.0640
20	64QAM	1	1	20.53	20.43	20.48	-3.8	0.0471	0.0460	0.0466
20	256QAM	1	1	18.42	18.41	18.52	-3.8	0.0290	0.0289	0.0296
Channel				371500	376000	380500	Gain	EIRP	EIRP	EIRP
Frequency (MHz)				1857.5	1880	1902.5				
15	QPSK	1	1	22.97	22.93	23.03	-3.8	0.0826	0.0818	0.0838
15	16QAM	1	1	22.02	22.06	22.11	-3.8	0.0664	0.0670	0.0678
Channel				371000	376000	381000	Gain	EIRP	EIRP	EIRP
Frequency (MHz)				1855	1880	1905				
10	QPSK	1	1	22.91	22.96	22.89	-3.8	0.0815	0.0824	0.0811
10	16QAM	1	1	22.05	22.03	22.07	-3.8	0.0668	0.0665	0.0671
Channel				370500	376000	381500	Gain	EIRP	EIRP	EIRP
Frequency (MHz)				1852.5	1880	1907.5				
5	QPSK	1	1	22.88	22.91	22.86	-3.8	0.0809	0.0815	0.0805
5	16QAM	1	1	22.05	22.01	22.07	-3.8	0.0668	0.0662	0.0671



Peak-to-Average Ratio

Mode	FR1 N2 / 20MHz / DFT-S OFDM		
Mod.	PI/2 BPSK	QPSK	Limit: 13dB
RB Size	Full RB	Full RB	Result
Middle CH	4.93	4.99	PASS

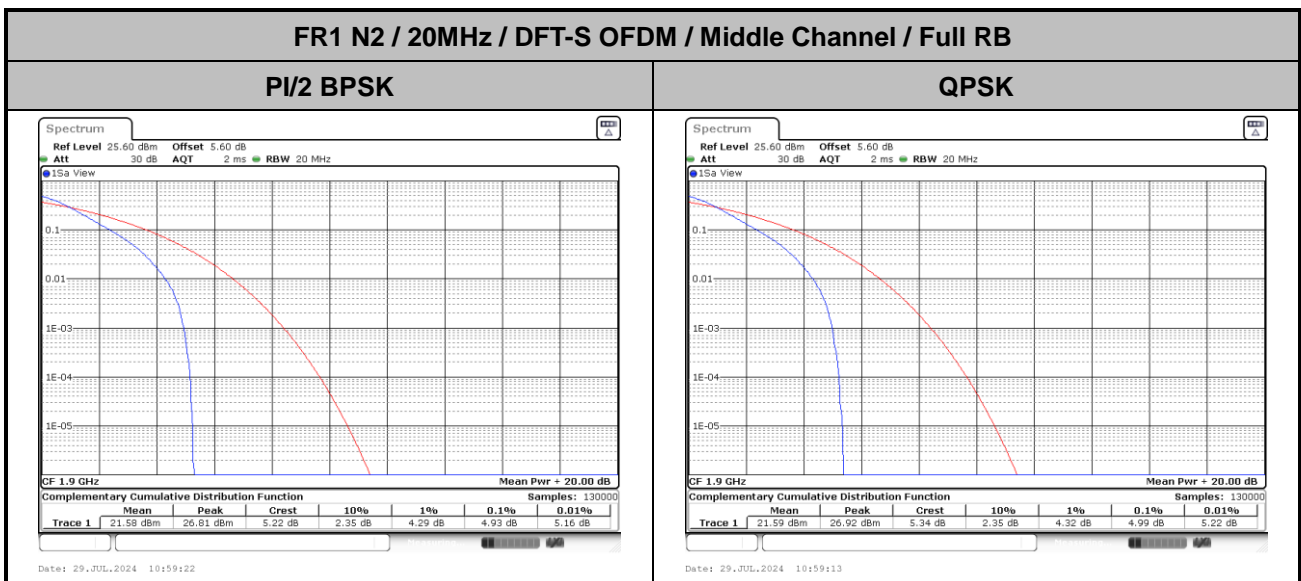



26dB Bandwidth

Mode	FR1 N2 : 26dBW (MHz) / CP OFDM							
BW	5MHz		10MHz		15MHz		20MHz	
Mod.	QPSK	16QAM	QPSK	16QAM	QPSK	16QAM	QPSK	16QAM
Middle CH	4.94	4.87	10.01	9.99	14.84	14.90	19.82	19.70
Mod.	64QAM	256QAM	64QAM	256QAM	64QAM	256QAM	64QAM	256QAM
Middle CH	4.84	4.78	10.03	10.03	14.90	14.93	19.74	19.82

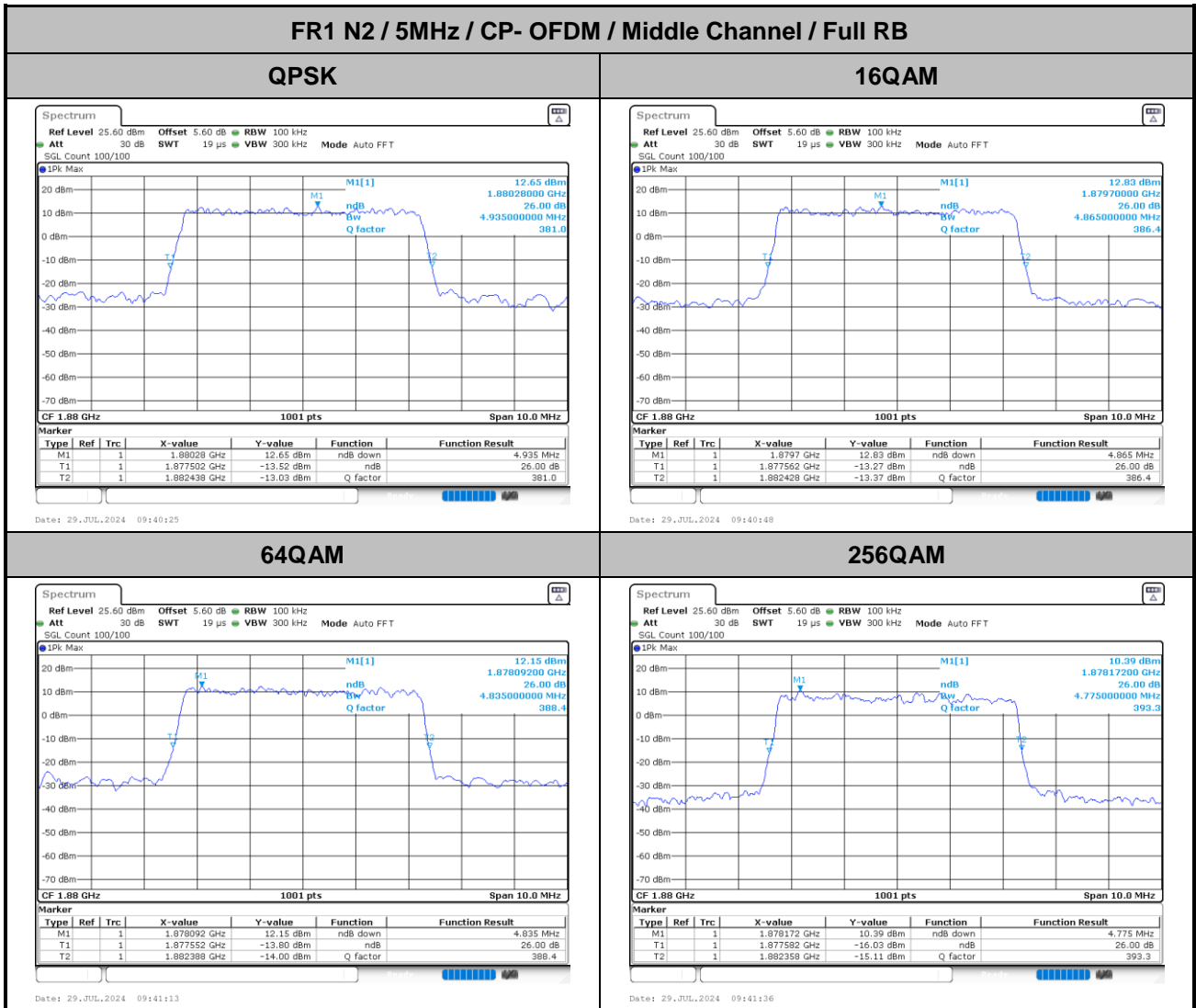



FR1 N2 / 10MHz / CP-S OFDM / Middle Channel / Full RB

QPSK

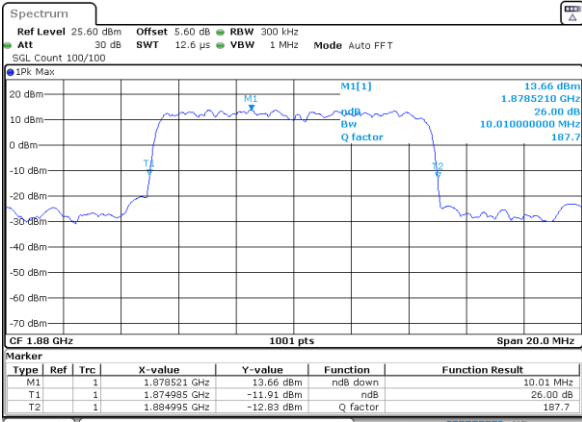

Date: 29_JUL_2024 09:52:05

16QAM

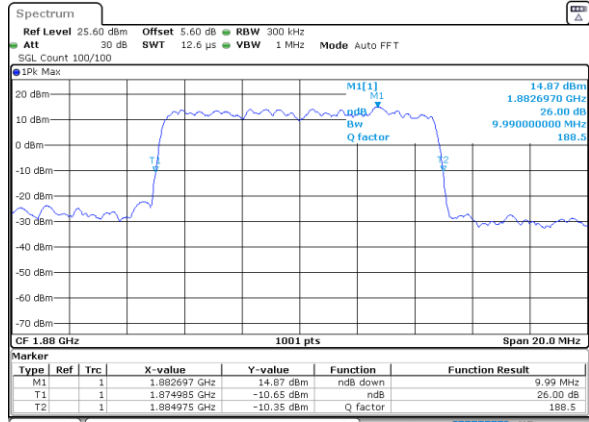

Date: 29_JUL_2024 09:52:35

64QAM

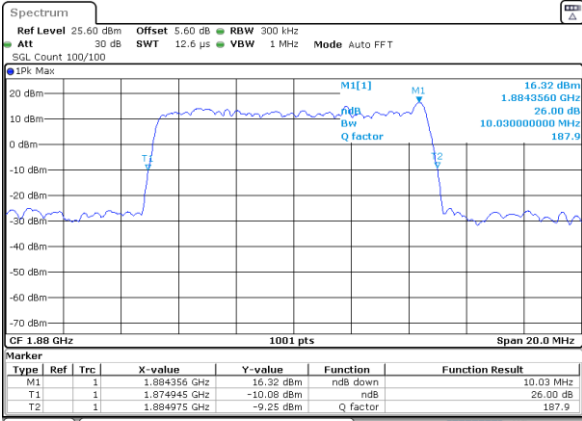

Date: 29_JUL_2024 09:53:01

256QAM

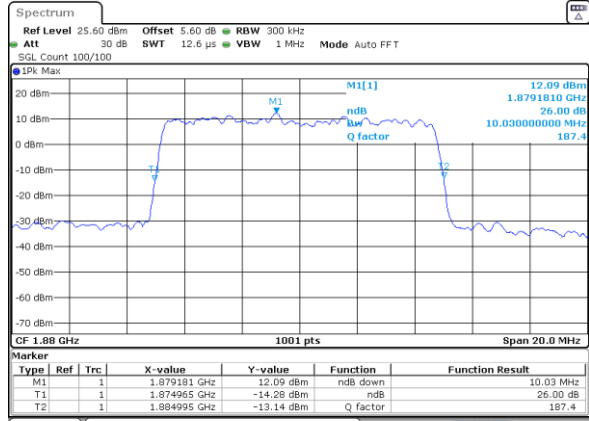

Date: 29_JUL_2024 09:53:28



FR1 N2 / 15MHz / CP-S OFDM / Middle Channel / Full RB

QPSK

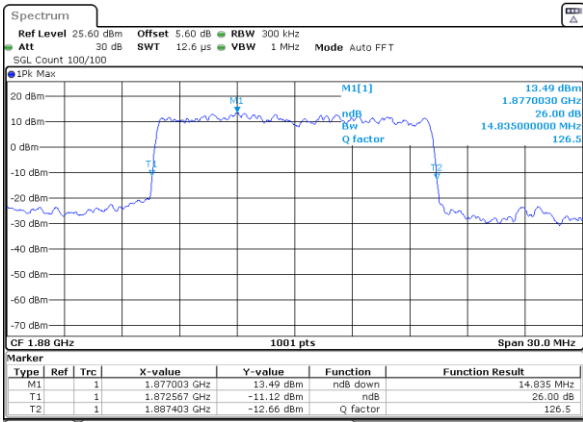

Date: 29_JUL_2024 10:19:34

16QAM

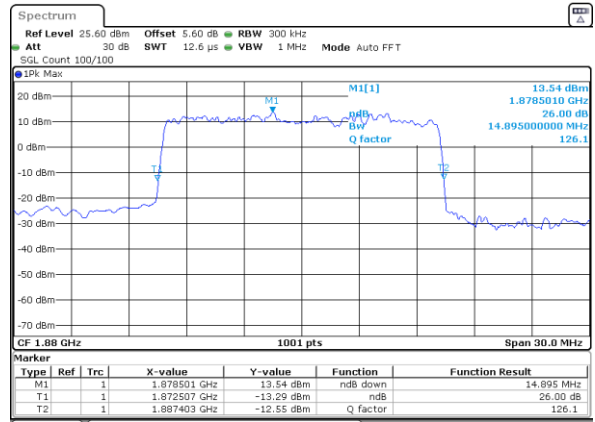

Date: 29_JUL_2024 10:20:08

64QAM

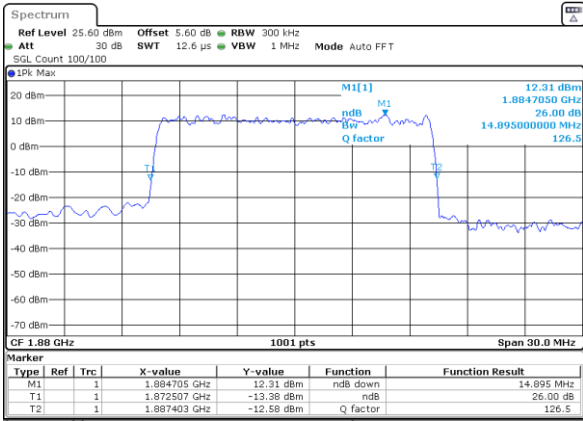

Date: 29_JUL_2024 10:20:34

256QAM

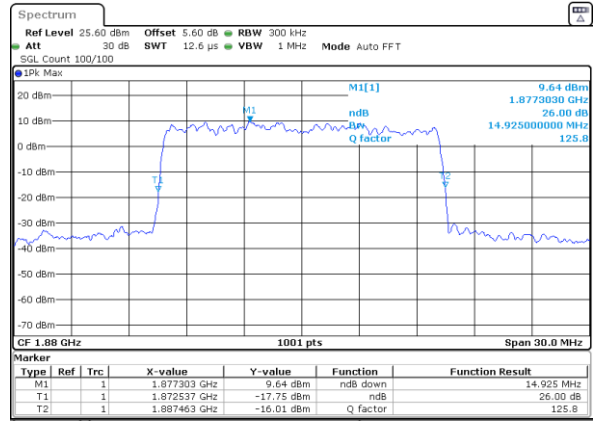

Date: 29_JUL_2024 10:21:00



FR1 N2 / 20MHz / DFT-S OFDM / Middle Channel / Full RB

QPSK

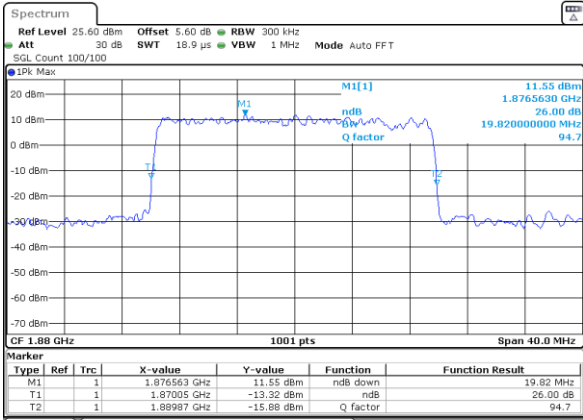

Date: 29_JUL_2024 10:42:39

16QAM

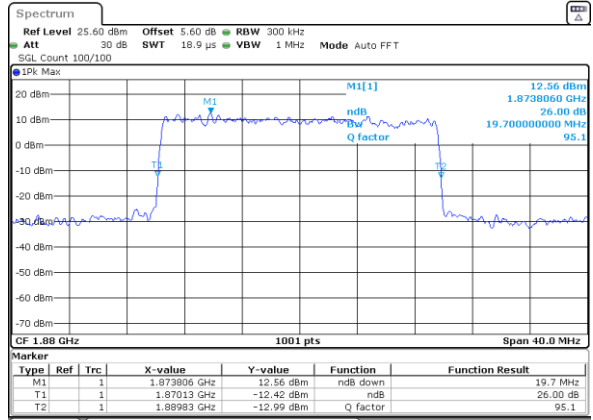

Date: 29_JUL_2024 10:43:42

64QAM

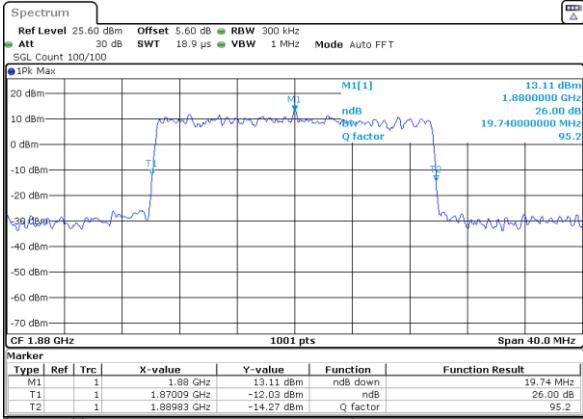

Date: 29_JUL_2024 10:44:12

256QAM

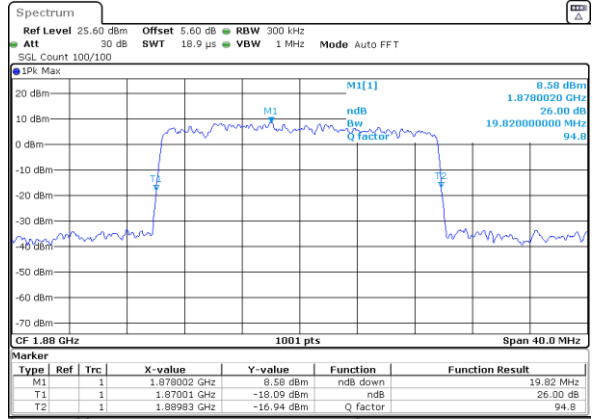

Date: 29_JUL_2024 10:44:39



Occupied Bandwidth

Mode	FR1 N2 : 99%OBW (MHz) / CP OFDM							
BW	5MHz		10MHz		15MHz		20MHz	
Mod.	QPSK	16QAM	QPSK	16QAM	QPSK	16QAM	QPSK	16QAM
Middle CH	4.48	4.50	9.29	9.39	14.12	14.06	18.90	18.90
Mod.	64QAM	256QAM	64QAM	256QAM	64QAM	256QAM	64QAM	256QAM
Middle CH	4.49	4.48	9.37	9.33	14.12	14.12	18.90	18.90

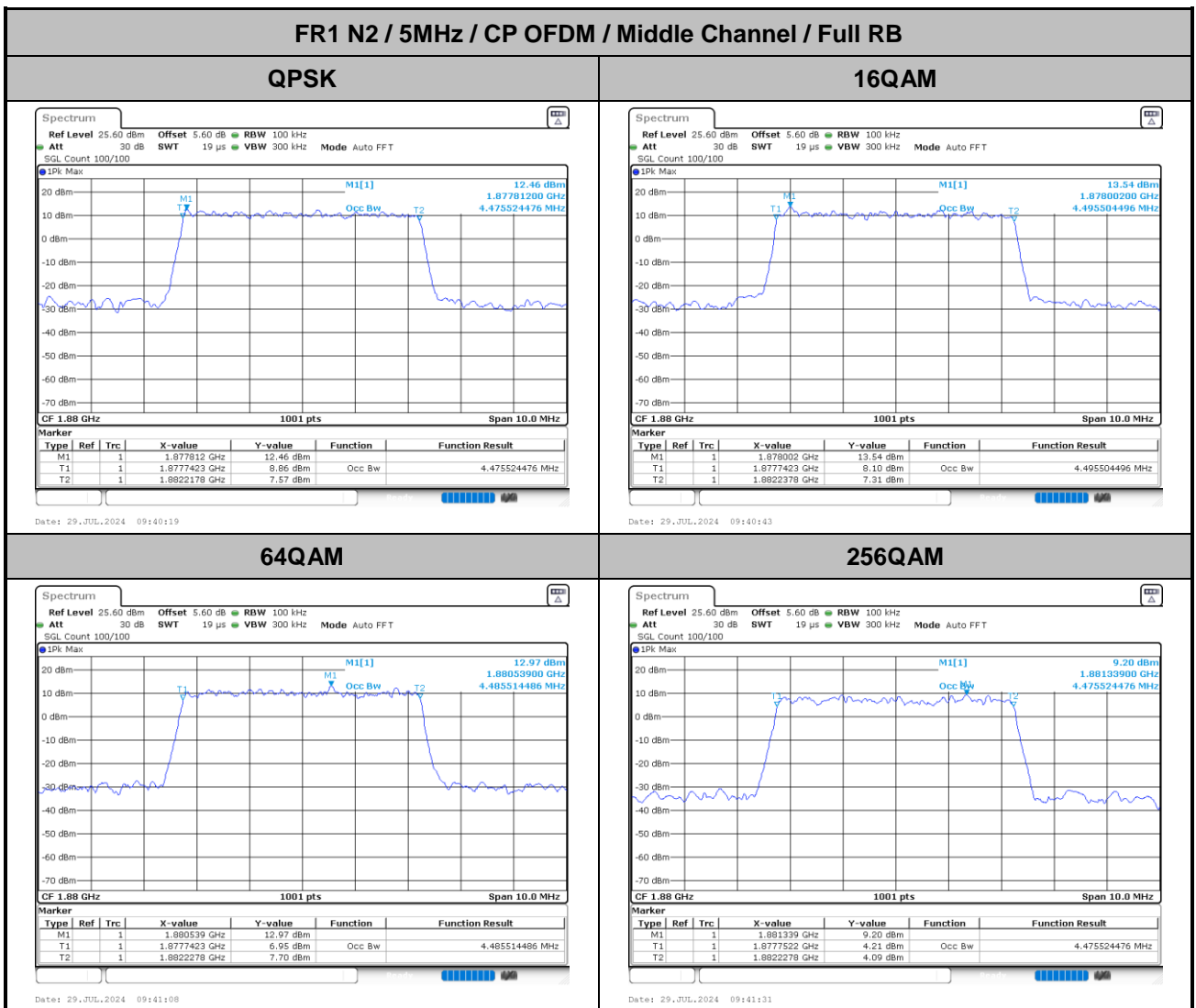



FR1 N2 / 10MHz / CP OFDM / Middle Channel / Full RB

QPSK

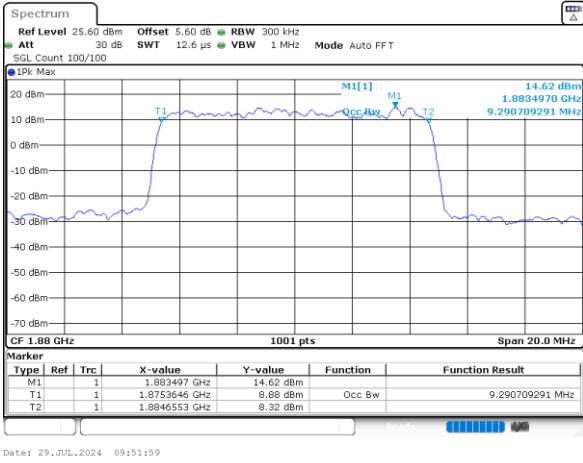

Date: 29_JUL_2024 09:51:59

16QAM

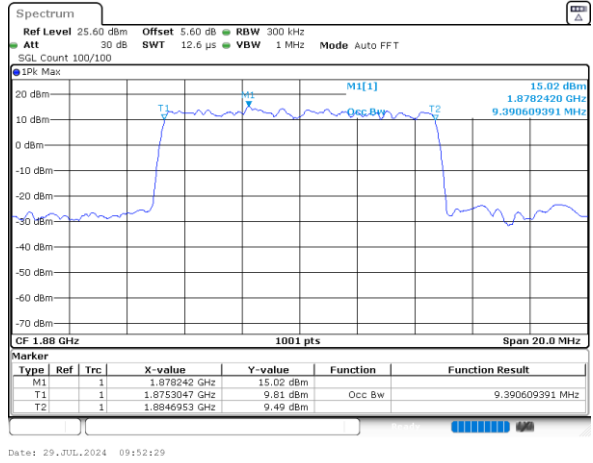

Date: 29_JUL_2024 09:52:29

64QAM

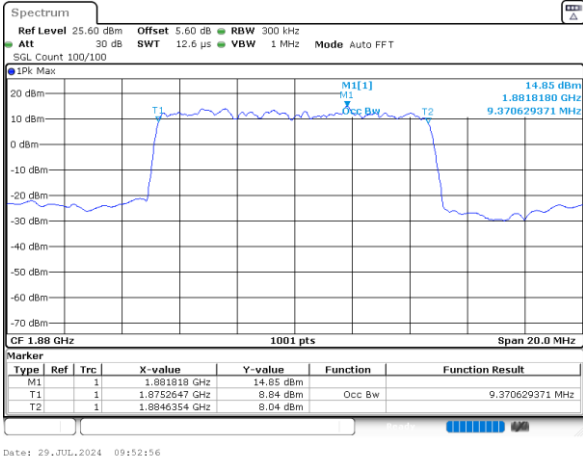

Date: 29_JUL_2024 09:52:56

64QAM

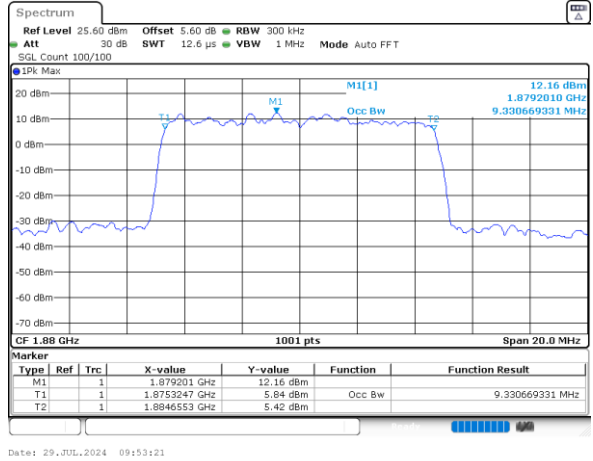

Date: 29_JUL_2024 09:53:21



FR1 N2 / 15MHz / CP OFDM / Middle Channel / Full RB

QPSK

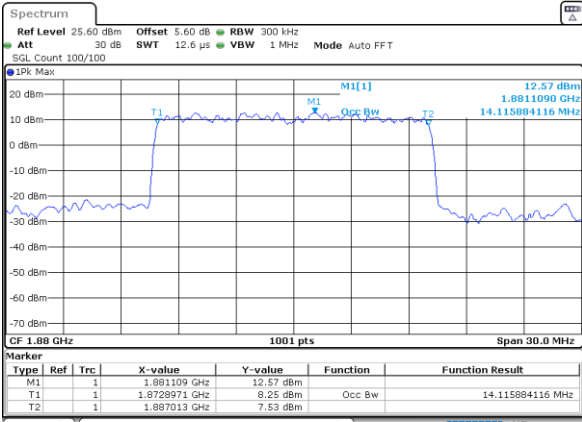

Date: 29_JUL_2024 10:19:25

16QAM

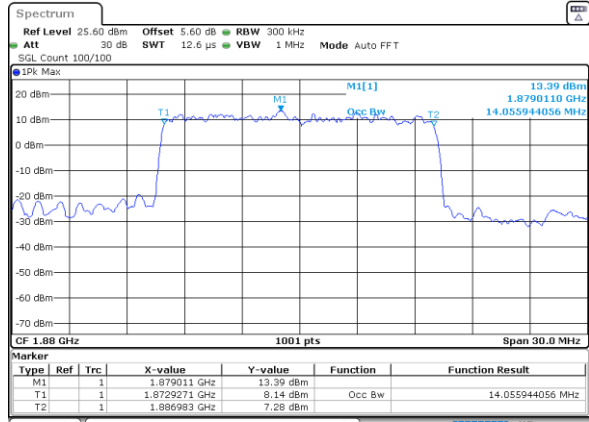

Date: 29_JUL_2024 10:20:03

64QAM

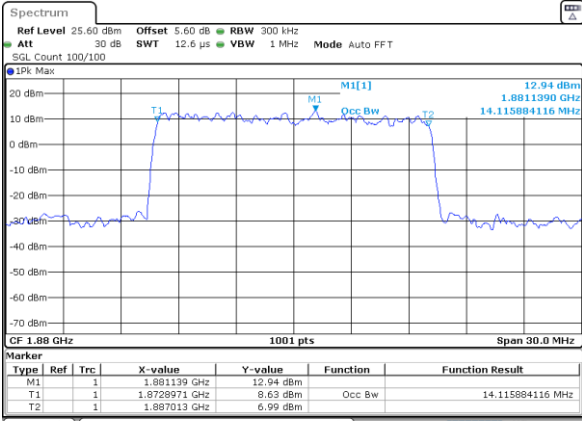

Date: 29_JUL_2024 10:20:29

256QAM

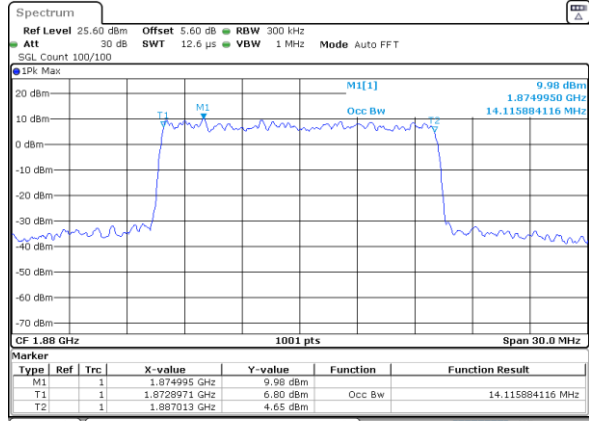

Date: 29_JUL_2024 10:20:54



FR1 N2 / 20MHz / CP OFDM / Middle Channel / Full RB

QPSK

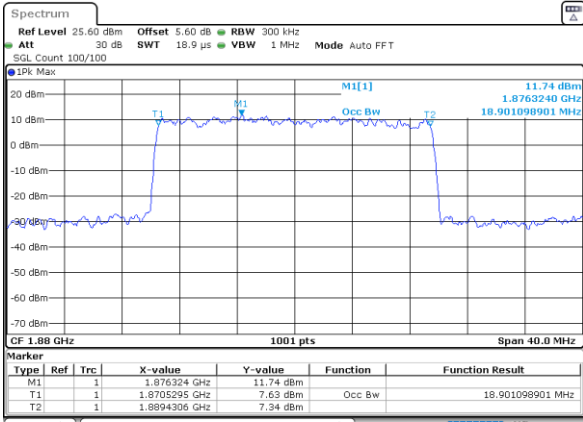

Date: 29_JUL_2024 10:42:33

16QAM

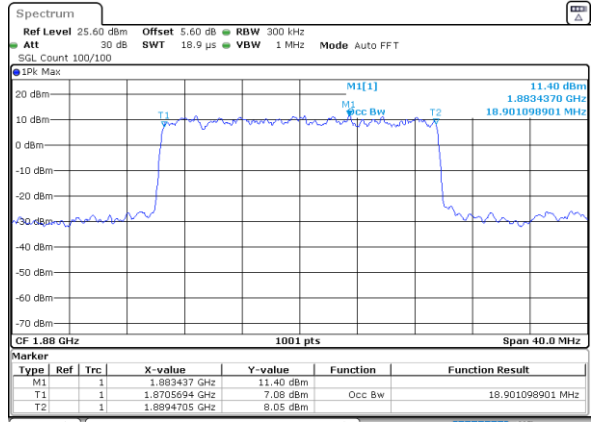

Date: 29_JUL_2024 10:43:37

64QAM

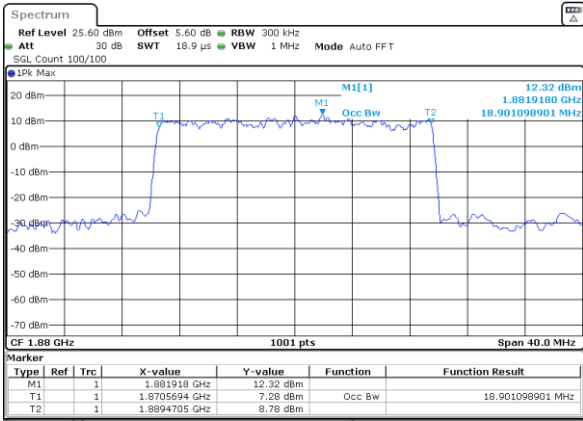

Date: 29_JUL_2024 10:44:06

256QAM

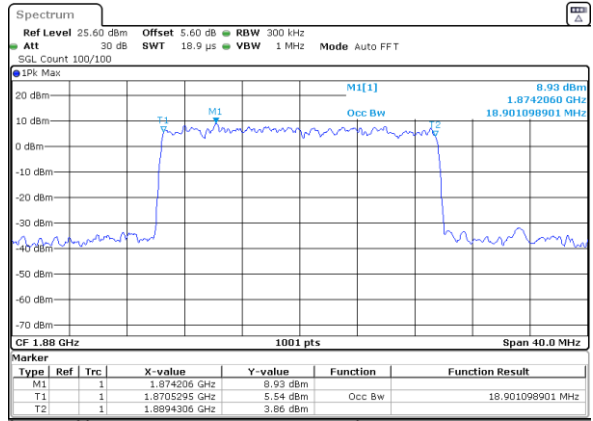

Date: 29_JUL_2024 10:44:34