



FCC RF Test Report

APPLICANT : Xiaomi Communications Co., Ltd.
EQUIPMENT : Mobile Phone
BRAND NAME : Xiaomi
MODEL NAME : 2405CPX3DG
FCC ID : 2AFZZPX3DG
STANDARD : 47 CFR Part 2, 96
CLASSIFICATION : Citizens Band End User Devices (CBE)
EQUIPMENT TYPE : End User Equipment
TEST DATE(S) : Apr. 14, 2024 ~ Apr. 23, 2024

We, Sporton International Inc. (Kunshan), would like to declare that the tested sample has been evaluated in accordance with the procedures given in ANSI / TIA / EIA-603-C-2004 and shown compliance with the applicable technical standards.

The test results in this report apply exclusively to the tested model / sample. Without written approval of Sporton International Inc. (Kunshan), the test report shall not be reproduced except in full.

Jason Jia



Approved by: Jason Jia

Sporton International Inc. (Kunshan)

**No. 1098, Pengxi North Road, Kunshan Economic Development Zone Jiangsu Province 215300
People's Republic of China**



Table of Contents

History of this test report..... 3

Summary of Test Result..... 4

1 General Description 5

 1.1 Applicant..... 5

 1.2 Manufacturer 5

 1.3 Feature of Equipment Under Test..... 5

 1.4 Maximum EIRP Power and Emission Designator 6

 1.5 Testing Site..... 6

 1.6 Test Software 6

 1.7 Applied Standards 7

2 Test Configuration of Equipment Under Test 8

 2.1 Test Mode..... 8

 2.2 Connection Diagram of Test System 9

 2.3 Support Unit used in test configuration 9

 2.4 Measurement Results Explanation Example 9

 2.5 Frequency List of Low/Middle/High Channels..... 10

3 Conducted Test Items..... 11

 3.1 Measuring Instruments..... 11

 3.2 Test Setup 11

 3.3 Conducted Output Power 12

 3.4 EIRP and PSD..... 13

 3.5 Occupied Bandwidth 14

 3.6 Conducted Band Edge 15

 3.7 Conducted Spurious Emission 16

 3.8 Frequency Stability..... 17

4 Radiated Test Items 18

 4.1 Measuring Instruments..... 18

 4.2 Test Setup 18

 4.3 Test Result of Radiated Test..... 19

 4.4 Radiated Spurious Emission 20

5 List of Measuring Equipment..... 21

6 Measurement Uncertainty 22

Appendix A. Test Results of Conducted Test

Appendix B. Test Results of Radiated Test

Appendix C. Test Setup Photographs



Summary of Test Result

Report Clause	Ref Std. Clause	Test Items	Result (PASS/FAIL)	Remark
3.3	§2.1046	Conducted Output Power	Reporting only	-
-	§96.41	Peak-to-Average Ratio	Not Applicable	Not applicable for End User Devices
3.4	§96.41	Maximum E.I.R.P	Pass	-
		Maximum Power Spectral Density	Not Applicable	Not applicable for End User Devices
3.5	§2.1049 §96.41	Occupied Bandwidth	Reporting only	-
3.6	§2.1051 §96.41	Conducted Band Edge Measurement Adjacent Channel Leakage Ratio	Pass	-
3.7	§2.1051 §96.41	Conducted Spurious Emission	Pass	
3.8	§2.1055	Frequency Stability for Temperature & Voltage	Pass	-
4.4	§2.1051 §96.41	Radiated Spurious Emission	Pass	Under limit 18.43 dB at 10824.00 MHz

Conformity Assessment Condition:
1. The test results (PASS/FAIL) with all measurement uncertainty excluded are presented against the regulation limits or in accordance with the requirements stipulated by the applicant/manufacturer who shall bear all the risks of non-compliance that may potentially occur if measurement uncertainty is taken into account.
2. The measurement uncertainty please refer to each test result in the section "Measurement Uncertainty"
Disclaimer:
The product specifications of the EUT presented in the test report that may affect the test assessments are declared by the manufacturer who shall take full responsibility for the authenticity.



1 General Description

1.1 Applicant

Xiaomi Communications Co., Ltd.

#019, 9th Floor, Building 6, 33 Xi'erqi Middle Road, Haidian District, Beijing, China, 100085

1.2 Manufacturer

Xiaomi Communications Co., Ltd.

#019, 9th Floor, Building 6, 33 Xi'erqi Middle Road, Haidian District, Beijing, China, 100085

1.3 Feature of Equipment Under Test

Product Feature	
Equipment	Mobile Phone
Brand Name	Xiaomi
Model Name	2405CPX3DG
FCC ID	2AFZZPX3DG
Tx Frequency	5G NR n48: 3550 MHz ~ 3700 MHz
Rx Frequency	5G NR n48: 3550 MHz ~ 3700 MHz
SCS	30kHz
Bandwidth	10MHz / 15MHz / 20MHz / 30MHz / 40MHz
Antenna Gain	Open: <Ant. 1> LTE Band 48: -3.3 dBi <Ant. 6> LTE Band 48: -6.0 dBi <Ant. 7> LTE Band 48: -0.15 dBi <Ant. 8> LTE Band 48: -2.5 dBi Close: <Ant. 1> LTE Band 48: -6.6 dBi <Ant. 6> LTE Band 48: -7.1 dBi <Ant. 7> LTE Band 48: -1.7 dBi <Ant. 8> LTE Band 48: -5.0 dBi
Type of Modulation	DFT-s-OFDM (PI/2 BPSK / QPSK / 16QAM / 64QAM / 256QAM) CP-OFDM (QPSK / 16QAM / 64QAM / 256QAM)
IMEI Code	Conducted : 866568070020507/866568070020515 Radiation : 866568070019426/866568070019434
HW Version	135100N8
SW Version	Xiaomi HyperOS 1.0
EUT Stage	Identical Prototype

Remark:

1. The above EUT's information was declared by manufacturer. Please refer to the specifications or user's manual for more detailed description.
2. The device is a folding phone, maximum EIRP is calculated from max output power and antenna gain, only the maximum EIRP of Ant. 7 is shown in the report.



1.4 Maximum EIRP Power and Emission Designator

5G NR n48		PI/2 BPSK / QPSK		16QAM/64QAM/256QAM	
BW (MHz)	Frequency Range (MHz)	Maximum EIRP(W)	Emission Designator (99%OBW)	Maximum EIRP(W)	Emission Designator (99%OBW)
10	3555.00~3694.98	0.1986	8M58G7D	0.1549	8M56W7D
15	3557.52~3692.49	0.1982	13M6G7D	0.1552	13M6W7D
20	3560.01~3690.00	0.1334	18M2G7D	0.1303	18M2W7D
30	3565.02~3684.99	0.1271	27M8G7D	0.1256	27M9W7D
40	3570.00~3679.98	0.1256	37M9G7D	0.1216	37M8W7D

Note: All modulations have been tested, only the worst test results of PSK & QAM are shown in the report.

1.5 Testing Site

Sporton International Inc. (Kunshan) is accredited to ISO/IEC 17025:2017 by American Association for Laboratory Accreditation with Certificate Number 5145.02.

Test Firm	Sporton International Inc. (Kunshan)		
Test Site Location	No. 1098, Pengxi North Road, Kunshan Economic Development Zone Jiangsu Province 215300 People's Republic of China TEL : +86-512-57900158		
Test Site No.	Sporton Site No.	FCC Designation No.	FCC Test Firm Registration No.
	03CH04-KS TH01-KS	CN1257	314309

1.6 Test Software

Item	Site	Manufacture	Name	Version
1.	TH01-KS	SPORTON	FCC LTE_Ver2.0 Auto_china_210503	2.0
2.	03CH04-KS	AUDIX	E3	210616



1.7 Applied Standards

According to the specifications of the manufacturer, the EUT must comply with the requirements of the following standards:

- ♦ ANSI C63.26-2015
- ♦ 47 CFR Part 2, 96
- ♦ FCC KDB 971168 D01 Power Meas. License Digital Systems v03r01
- ♦ FCC KDB 940660 D01 Part 96 CBRS v03
- ♦ FCC KDB 412172 D01 Determining ERP and EIRP v01r01

Remark:

1. All test items were verified and recorded according to the standards and without any deviation during the test.
2. This EUT has also been tested and complied with the requirements of FCC Part 15, Subpart B, recorded in a separate test report.



2 Test Configuration of Equipment Under Test

2.1 Test Mode

Antenna port conducted and radiated test items listed below are performed according to KDB 971168 D01 Power Meas. License Digital Systems v03r01 with maximum output power.

For radiated measurement, pre-scanned in three orthogonal panels, X, Y, Z. The worst cases (Y plane) were recorded in this report.

Test Items	Band	Bandwidth (MHz)						Modulation					RB #			Test Channel		
		1.4	10	15	20	30	40	PI/2 BPSK	QPSK	16 QAM	64 QAM	256 QAM	1	Half	Full	L	M	H
Max. Output Power	n48	-	v	v	v	v	v	v	v	v	v	v	v		v	v	v	v
Adjacent Channel Leakage Ratio	n48	-	v		v		v	v	v				v		v	v	v	v
26dB and 99% Bandwidth	n48	-	v	v	v	v	v		v	v	v	v			v		v	
Conducted Band Edge	n48	-	v		v		v	v	v				v		v	v	v	v
Conducted Spurious Emission	n48	-	v		v		v	v	v				v			v	v	v
E.I.R.P	n48	-	v	v	v	v	v	v	v	v	v		v			v	v	v
Frequency Stability	n48	-			v				v						v		v	
Radiated Spurious Emission	n48	Worst Case															v	
Remark	<ol style="list-style-type: none"> The mark "v " means that this configuration is chosen for testing The mark "- " means that this bandwidth is not supported. The device is investigated from 30MHz to 10 times of fundamental signal for radiated spurious emission test under different RB size/offset and modulations in exploratory test. Subsequently, only the worst case emissions are reported. Frequency Stability : Normal Voltage = 3.86V ; Low Voltage =3.60V. ; High Voltage =4.30V 																	

2.2 Connection Diagram of Test System

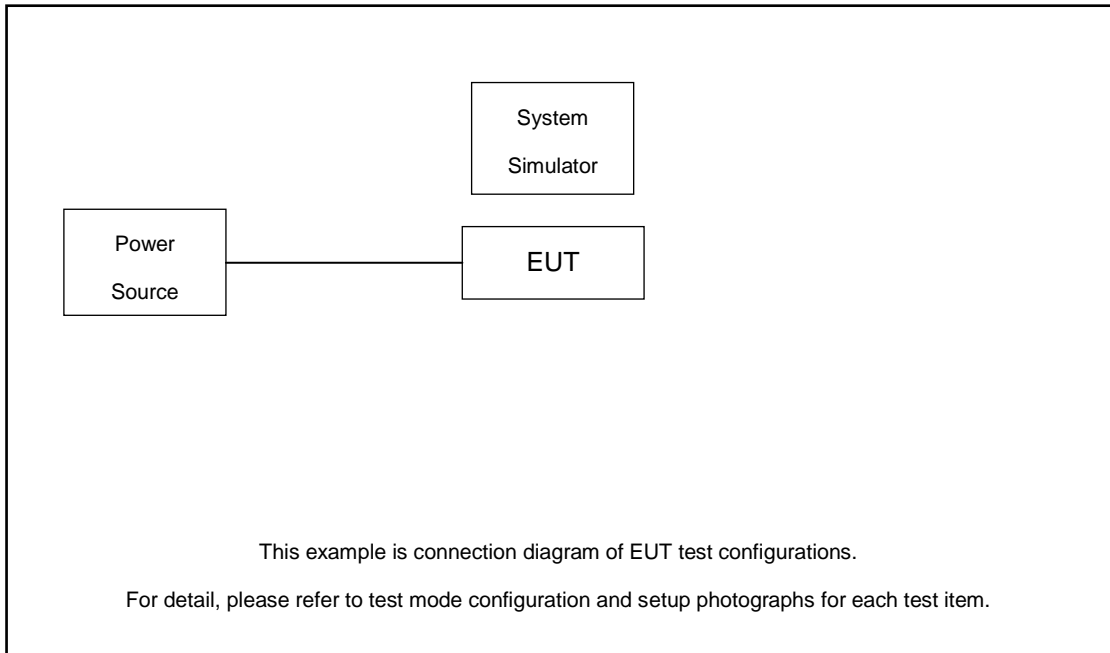

2.3 Support Unit used in test configuration

Item	Equipment	Trade Name	Model No.	FCC ID	Data Cable	Power Cord
1.	Power Supply	GWINSTEK	PSS-2002	N/A	N/A	Unshielded, 1.8 m
2.	NR Base Station	Anritsu	MT8000A	N/A	N/A	Unshielded, 1.8 m

2.4 Measurement Results Explanation Example

For all conducted test items:

The offset level is set in the spectrum analyzer to compensate the RF cable loss and attenuator factor between EUT conducted output port and spectrum analyzer. With the offset compensation, the spectrum analyzer reading level is exactly the EUT RF output level.

The spectrum analyzer offset is derived from RF cable loss and attenuator factor.

Offset = RF cable loss + attenuator factor.

Following shows an offset computation example with cable loss 6.5 dB and 20dB attenuator.

Example :

Offset(dB) = RF cable loss(dB) + attenuator factor(dB).

$$= 6.5 + 20 = 26.5 \text{ (dB)}$$



2.5 Frequency List of Low/Middle/High Channels

5G NR n48 Channel and Frequency List				
BW [MHz]	Channel/Frequency(MHz)	Lowest	Middle	Highest
40	Channel	638000	641666	645332
	Frequency	3570	3624.99	3679.98
30	Channel	637668	641666	645666
	Frequency	3565.02	3624.99	3684.99
20	Channel	637334	641666	646000
	Frequency	3560.01	3624.99	3690
15	Channel	637168	641666	646166
	Frequency	3557.52	3624.99	3692.49
10	Channel	637000	641666	646332
	Frequency	3555	3624.99	3694.98

3 Conducted Test Items

3.1 Measuring Instruments

See list of measuring instruments of this test report.

3.2 Test Setup

3.2.1 Conducted Output Power / ACLR



3.2.2 26dB & 99% Occupied Bandwidth, Conducted Band-Edge and Conducted Spurious Emission



3.2.3 Frequency Stability

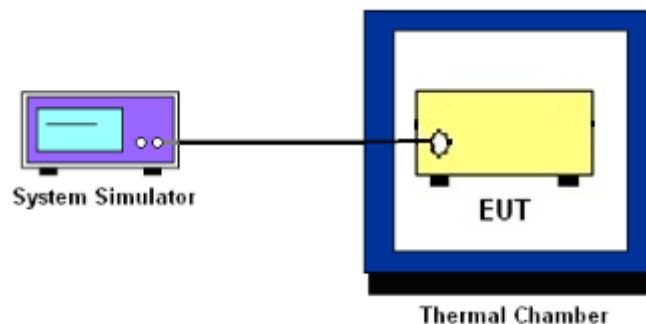

3.2.4 Test Result of Conducted Test

Please refer to Appendix A.



3.3 Conducted Output Power

3.3.1 Description of the Conducted Output Power Measurement

A system simulator was used to establish communication with the EUT. Its parameters were set to force the EUT transmitting at maximum output power. The measured power in the radio frequency on the transmitter output terminals shall be reported.

3.3.2 Test Procedures

1. The transmitter output port was connected to the system simulator.
2. Set EUT at maximum power through the system simulator.
3. Select lowest, middle, and highest channels for each band and different modulation.
4. Measure and record the power level from the system simulator.

3.4 EIRP and PSD

3.4.1 Description of the EIRP and PSD Measurement

EIRP and PSD limits for CBRS equipment as below table:

Device		Maximum EIRP (dBm/10 MHz)	Maximum PSD (dBm/MHz)
Applied	End User Device	23	n/a
<input type="checkbox"/>	Category A CBSD	30	20
<input type="checkbox"/>	Category B CBSD	47	37

Remark:

The worst case EIRP shown in this section is found with LTE operating only using 1RB. As such, the EIRP/10MHz and full channel EIRP values will be identical since 1RB is fully contained within all available channel bandwidths for LTE Band 48 (i.e. 5, 10, 15, 20MHz)

3.4.2 Test Procedures for EIRP

1. Establishing a communications link with the call box (Base station) to measure the Maximum conducted power, the parameters were set to force the EUT transmitting at maximum output power level. Use the average power measurement function to measure total channel power of each channel bandwidth (per ANSI C63.26-2015 Section 5.2.1)
2. Determining ERP and/or EIRP from conducted RF output power measurements (Per ANSI C63.26-2015 Section 5.2.5.5)
 - EIRP = $P_T + G_T - L_C$, ERP = EIRP -2.15, where
 - P_T = transmitter output power in dBm
 - G_T = gain of the transmitting antenna in dBi
 - L_C = signal attenuation in the connecting cable between the transmitter and antenna in dB



3.5 Occupied Bandwidth

3.5.1 Description of Occupied Bandwidth Measurement

The occupied bandwidth is the width of a frequency band such that, below the lower and above the upper frequency limits, the mean powers emitted are each equal to a specified percentage 0.5% of the total mean transmitted power.

The 26 dB emission bandwidth is defined as the frequency range between two points, one above and one below the carrier frequency, at which the spectral density of the emission is attenuated 26 dB below the maximum in-band spectral density of the modulated signal. Spectral density (power per unit bandwidth) is to be measured with a detector of resolution bandwidth equal to approximately 1.0% of the emission bandwidth.

3.5.2 Test Procedures

The testing follows ANSI C63.26-2015 Section 5.4.3 (26dB) and Section 5.4.4 (99OB)

1. The EUT was connected to spectrum analyzer and system simulator via a power divider.
2. The spectrum analyzer center frequency is set to the nominal EUT channel center frequency. The span range for the spectrum analyzer shall be between two and five times the anticipated OBW.
3. The nominal resolution bandwidth (RBW) shall be in the range of 1 to 5 % of the anticipated OBW, and the VBW shall be at least 3 times the RBW.
4. Set the detection mode to peak, and the trace mode to max hold.
5. Determine the reference value: Set the EUT to transmit a modulated signal. Allow the trace to stabilize. Set the spectrum analyzer marker to the highest level of the displayed trace.
(this is the reference value)
6. Determine the “-26 dB down amplitude” as equal to (Reference Value – X).
7. Place two markers, one at the lowest and the other at the highest frequency of the envelope of the spectral display such that each marker is at or slightly below the “-X dB down amplitude” determined in step 6. If a marker is below this “-X dB down amplitude” value it shall be placed as close as possible to this value. The OBW is the positive frequency difference between the two markers.
8. Use the 99 % power bandwidth function of the spectrum analyzer and report the measured bandwidth.

3.6 Conducted Band Edge

3.6.1 Description of Conducted Band Edge Measurement

Part 96.41 (e) (1) (ii)

For End User Devices the emission limits outside the fundamental are as follows:

Within 0 MHz to B MHz above and below the assigned channel ≤ -13 dBm/MHz

Greater than B MHz above and below the assigned channel ≤ -25 dBm/MHz

where B is the bandwidth in megahertz of the assigned channel or multiple contiguous channels of the End User Device.

Notwithstanding the emission limits in this paragraph, the Adjacent Channel Leakage Ratio for End User Devices shall be at least 30 dB.

Part 96.41 (e) (2)

For CBSDs and End User Devices, the conducted power of emissions below 3540 MHz or above 3710 MHz shall not exceed -25 dBm/MHz, and the conducted power of emissions below 3530 MHz or above 3720 MHz shall not exceed -40 dBm/MHz

3.6.2 Test Procedures

The testing follows FCC KDB 971168 D01 v03r01 Section 6.1.

1. The EUT was connected to spectrum analyzer and system simulator via a power divider.
2. The band edges of low and high channels for the highest RF powers were measured.
3. Set RBW $\geq 1\%$ EBW in the 1MHz band immediately outside and adjacent to the band edge.
4. Beyond the 1 MHz band from the band edge, RBW=1MHz was used
5. Offset has included the duty factor for LTE Band 48. Duty factor $=10 \log (1/x)$, where x is the measured duty cycle.
6. Set spectrum analyzer with RMS detector.
7. The RF fundamental frequency should be excluded against the limit line in the operating frequency band.



3.7 Conducted Spurious Emission

3.7.1 Description of Conducted Spurious Emission Measurement

96.41 (e)(2)

The conducted power of any emissions below 3530 MHz or above 3720 MHz shall not exceed -40dBm/MHz .

3.7.2 Test Procedures

The testing follows FCC KDB 971168 D01 v03r01 Section 6.1.

1. The EUT was connected to spectrum analyzer and system simulator via a power divider.
2. The RF output of EUT was connected to the spectrum analyzer by RF cable and attenuator. The path loss was compensated to the results for each measurement.
3. The middle channel for the highest RF power within the transmitting frequency was measured.
4. The conducted spurious emission for the whole frequency range was taken.
5. Make the measurement with the spectrum analyzer's RBW = 1MHz, VBW = 3MHz.
6. Set spectrum analyzer with RMS detector.
7. Taking the record of maximum spurious emission.
8. The RF fundamental frequency should be excluded against the limit line in the operating frequency band.
9. The limit line is -40dBm/MHz .



3.8 Frequency Stability

3.8.1 Description of Frequency Stability Measurement

The frequency stability shall be measured by variation of ambient temperature and variation of primary supply voltage to ensure that the fundamental emission stays within the authorized frequency block.

3.8.2 Test Procedures for Temperature Variation

The testing follows FCC KDB 971168 D01 v03r01 Section 9.0.

1. The EUT was set up in the thermal chamber and connected with the system simulator.
2. With power OFF, the temperature was decreased to -30°C and the EUT was stabilized before testing. Power was applied and the maximum change in frequency was recorded within one minute.
3. With power OFF, the temperature was raised in 10°C step up to 50°C . The EUT was stabilized at each step for at least half an hour. Power was applied and the maximum frequency change was recorded within one minute.

3.8.3 Test Procedures for Voltage Variation

The testing follows FCC KDB 971168 D01 v03r01 Section 9.0.

1. The EUT was placed in a temperature chamber at $25\pm 5^{\circ}\text{C}$ and connected with the system simulator.
2. The power supply voltage to the EUT was varied from 85% to 115% of the nominal value measured at the input to the EUT.
3. The variation in frequency was measured for the worst case.

4 Radiated Test Items

4.1 Measuring Instruments

See list of measuring instruments of this test report.

4.2 Test Setup

4.2.1 For radiated test below 30MHz

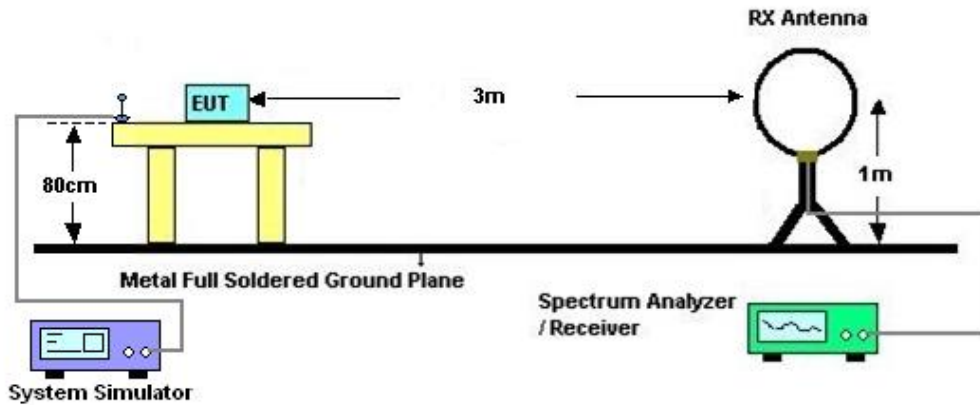

4.2.2 For radiated test from 30MHz to 1GHz

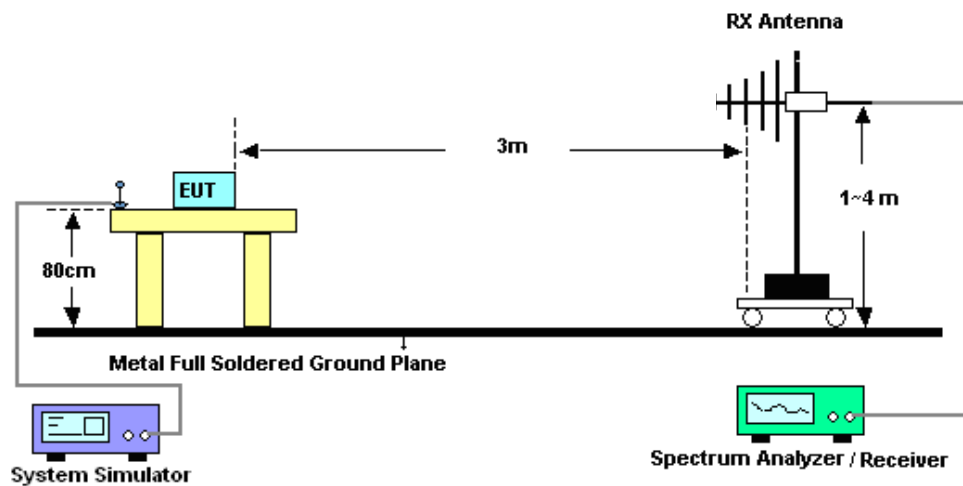

4.2.3 For radiated test above 1GHz

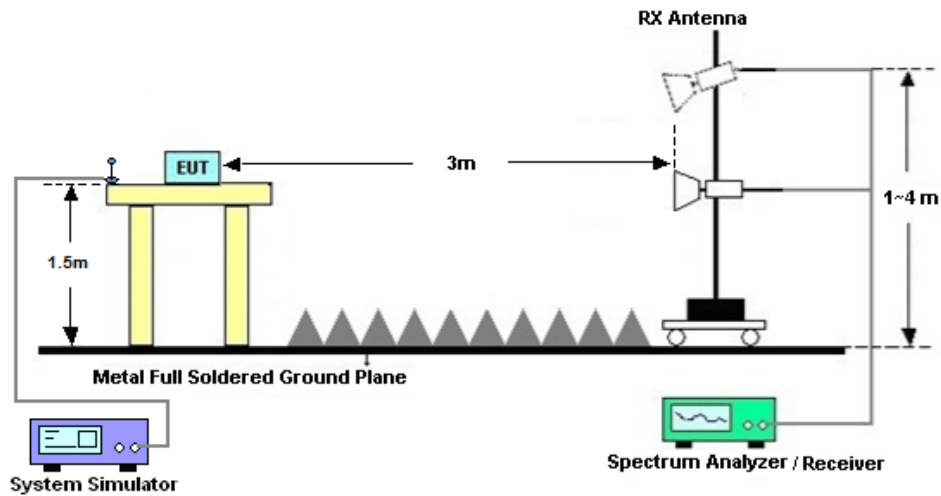

4.3 Test Result of Radiated Test

The low frequency, which started from 9 kHz to 30MHz, was pre-scanned and the result which was 20dB lower than the limit line was not reported.

Please refer to Appendix B.



4.4 Radiated Spurious Emission

4.4.1 Description of Radiated Spurious Emission Measurement

The radiated spurious emission was measured by substitution method according to ANSI C63.26-2015. The power of any emission outside of the authorized operating frequency ranges must be attenuated below the transmitter power (P) by a factor of at least -40dBm / MHz. The spectrum is scanned from 30 MHz up to a frequency including its 10th harmonic.

4.4.2 Test Procedures

1. The EUT was placed on a turntable with 0.8 meter height for frequency below 1GHz and 1.5 meter height for frequency above 1GHz respectively above ground.
2. The EUT was set 3 meters from the receiving antenna mounted on the antenna tower.
3. The table was rotated 360 degrees to determine the position of the highest spurious emission.
4. The height of the receiving antenna is varied between 1m to 4m to search the maximum spurious emission for both horizontal and vertical polarizations.
5. During the measurement, the system simulator parameters were set to force the EUT transmitting at maximum output power.
6. Make the measurement with the spectrum analyzer's RBW = 1MHz, VBW = 3MHz, taking the record of maximum spurious emission.
7. A horn antenna was substituted in place of the EUT and was driven by a signal generator. Tune the output power of signal generator to the same emission level with EUT maximum spurious emission.
$$\text{EIRP (dBm)} = \text{S.G. Power} - \text{Tx Cable Loss} + \text{Tx Antenna Gain}$$
$$\text{ERP (dBm)} = \text{EIRP} - 2.15$$
8. The RF fundamental frequency should be excluded against the limit line in the operating frequency band.
The limit line is -40dBm/MHz



5 List of Measuring Equipment

Instrument	Manufacturer	Model No.	Serial No.	Characteristics	Calibration Date	Test Date	Due Date	Remark
Spectrum Analyzer	R&S	FSV40	101040	10Hz~40GHz	Oct. 11, 2023	Apr. 19, 2024~ Apr. 23, 2024	Oct. 10, 2024	Conducted (TH01-KS)
Power divider	STI	STI08-0055	-	0.5~40GHz	NCR	Apr. 19, 2024~ Apr. 23, 2024	NCR	Conducted (TH01-KS)
Temperature & humidity chamber	Hongzhan	LP-150U	H2014011 440	-40~+150°C 20%~95%RH	Jul. 06, 2023	Apr. 19, 2024~ Apr. 23, 2024	Jul. 05, 2024	Conducted (TH01-KS)
EXA Spectrum Analyzer	Keysight	N9010B	MY574710 79	10Hz-44G,MAX 30dB	Oct. 10, 2023	Apr. 14, 2024	Oct. 09, 2024	Radiation (03CH04-KS)
Loop Antenna	R&S	HFH2-Z2E	101125	9kHz~30MHz	Sep. 11 2023	Apr. 14, 2024	Sep. 10, 2024	Radiation (03CH04-KS)
Bilog Antenna	TeseQ	CBL6111D	59913	30MHz-1GHz	Aug. 19, 2023	Apr. 14, 2024	Aug. 18, 2024	Radiation (03CH04-KS)
Double Ridge Horn Antenna	ETS-Lindgren	3117	00251694	1GHz~18GHz	Jul. 12, 2023	Apr. 14, 2024	Jul. 11, 2024	Radiation (03CH04-KS)
SHF-EHF Horn	Com-power	AH-840	101070	18GHz~40GHz	Jan. 05, 2024	Apr. 14, 2024	Jan. 04, 2025	Radiation (03CH04-KS)
Amplifier	SONOMA	310N	380827	9KHz-1GHz	Jul. 06, 2023	Apr. 14, 2024	Jul. 05, 2024	Radiation (03CH04-KS)
Amplifier	MITEQ	EM18G40GG A	060728	18~40GHz	Jan. 05, 2024	Apr. 14, 2024	Jan. 04, 2025	Radiation (03CH04-KS)
high gain Amplifier	EM	EM01G18GA	060840	1Ghz-18Ghz	Oct. 10, 2023	Apr. 14, 2024	Oct. 09, 2024	Radiation (03CH04-KS)
Amplifier	Agilent	8449B	3008A023 70	1Ghz-18Ghz	Oct. 10, 2023	Apr. 14, 2024	Oct. 09, 2024	Radiation (03CH04-KS)
AC Power Source	Chroma	61601	F1040900 04	N/A	NCR	Apr. 14, 2024	NCR	Radiation (03CH04-KS)
Turn Table	ChamPro	EM 1000-T	060762-T	0~360 degree	NCR	Apr. 14, 2024	NCR	Radiation (03CH04-KS)
Antenna Mast	ChamPro	EM 1000-A	060762-A	1 m~4 m	NCR	Apr. 14, 2024	NCR	Radiation (03CH04-KS)

NCR: No Calibration Required



6 Measurement Uncertainty

Uncertainty of Conducted Measurement

Conducted Spurious Emission & Bandedge	±2.26 dB
Occupied Channel Bandwidth	±0.1%
Conducted Power	±0.46 dB
Peak to Average Ratio	±0.46 dB
Frequency Stability	±0.4 Hz

Uncertainty of Radiated Emission Measurement (30 MHz ~ 1000 MHz)

Measuring Uncertainty for a Level of Confidence of 95% (U = 2Uc(y))	3.82 dB
---	---------

Uncertainty of Radiated Emission Measurement (1 GHz ~ 18 GHz)

Measuring Uncertainty for a Level of Confidence of 95% (U = 2Uc(y))	3.56 dB
---	---------

Uncertainty of Radiated Emission Measurement (18 GHz ~ 40 GHz)

Measuring Uncertainty for a Level of Confidence of 95% (U = 2Uc(y))	3.54 dB
---	---------

----- THE END -----



Appendix A. Test Results of Conducted Test

Test Engineer :	Simle Wang	Temperature :	22~23°C
		Relative Humidity :	40~42%

FR1 N48 (ANT7)

Transmitter Conducted Output Power And EIRP, (G_T - L_C)=-0.15dBi

NR Band	SCS	BandWidth	Arfcn	Freq(M Hz)	Modulation	RB	Conducted Power(dBm)	EIRP(dBm)	EIRP(W)
48	30	40	638000	3570	DFT-s-OFDM PI/2 BPSK	50@25	14.43	14.28	0.0268
48	30	40	638000	3570	DFT-s-OFDM PI/2 BPSK	1@1	14.34	14.19	0.0262
48	30	40	638000	3570	DFT-s-OFDM PI/2 BPSK	1@104	14.31	14.16	0.0261
48	30	40	638000	3570	DFT-s-OFDM QPSK	50@25	14.39	14.24	0.0265
48	30	40	638000	3570	DFT-s-OFDM QPSK	1@1	14.33	14.18	0.0262
48	30	40	638000	3570	DFT-s-OFDM QPSK	1@104	14.34	14.19	0.0262
48	30	40	638000	3570	DFT-s-OFDM 16 QAM	50@25	13.89	13.74	0.0237
48	30	40	638000	3570	DFT-s-OFDM 16 QAM	1@1	13.92	13.77	0.0238
48	30	40	638000	3570	DFT-s-OFDM 16 QAM	1@104	13.92	13.77	0.0238
48	30	40	638000	3570	DFT-s-OFDM 64 QAM	50@25	13.84	13.69	0.0234
48	30	40	638000	3570	DFT-s-OFDM 64 QAM	1@1	13.7	13.55	0.0226
48	30	40	638000	3570	DFT-s-OFDM 64 QAM	1@104	13.72	13.57	0.0228
48	30	40	638000	3570	DFT-s-OFDM 256 QAM	50@25	13.92	13.77	0.0238
48	30	40	638000	3570	DFT-s-OFDM 256 QAM	1@1	13.81	13.66	0.0232
48	30	40	638000	3570	DFT-s-OFDM 256 QAM	1@104	13.82	13.67	0.0233
48	30	40	638000	3570	CP-OFDM QPSK	53@26	13.58	13.43	0.0220
48	30	40	638000	3570	CP-OFDM QPSK	1@1	13.48	13.33	0.0215
48	30	40	638000	3570	CP-OFDM QPSK	1@104	13.5	13.35	0.0216
48	30	40	641666	3624.99	DFT-s-OFDM PI/2 BPSK	50@25	20.67	20.52	0.1127
48	30	40	641666	3624.99	DFT-s-OFDM PI/2 BPSK	1@1	21.14	20.99	0.1256
48	30	40	641666	3624.99	DFT-s-OFDM PI/2 BPSK	1@104	20.97	20.82	0.1208
48	30	40	641666	3624.99	DFT-s-OFDM QPSK	50@25	20.5	20.35	0.1084
48	30	40	641666	3624.99	DFT-s-OFDM QPSK	1@1	20.99	20.84	0.1213
48	30	40	641666	3624.99	DFT-s-OFDM QPSK	1@104	20.92	20.77	0.1194
48	30	40	641666	3624.99	DFT-s-OFDM 16 QAM	50@25	20.37	20.22	0.1052
48	30	40	641666	3624.99	DFT-s-OFDM 16 QAM	1@1	21	20.85	0.1216
48	30	40	641666	3624.99	DFT-s-OFDM 16 QAM	1@104	20.85	20.7	0.1175
48	30	40	641666	3624.99	DFT-s-OFDM 64 QAM	50@25	20.43	20.28	0.1067
48	30	40	641666	3624.99	DFT-s-OFDM 64 QAM	1@1	20.75	20.6	0.1148
48	30	40	641666	3624.99	DFT-s-OFDM 64 QAM	1@104	20.68	20.53	0.1130
48	30	40	641666	3624.99	DFT-s-OFDM 256	50@25	20.54	20.39	0.1094

					QAM				
48	30	40	641666	3624.99	DFT-s-OFDM 256 QAM	1@1	20.4	20.25	0.1059
48	30	40	641666	3624.99	DFT-s-OFDM 256 QAM	1@104	20.22	20.07	0.1016
48	30	40	641666	3624.99	CP-OFDM QPSK	53@26	20.42	20.27	0.1064
48	30	40	641666	3624.99	CP-OFDM QPSK	1@1	21.04	20.89	0.1227
48	30	40	641666	3624.99	CP-OFDM QPSK	1@104	21	20.85	0.1216
48	30	40	645332	3679.98	DFT-s-OFDM PI/2 BPSK	50@25	14.51	14.36	0.0273
48	30	40	645332	3679.98	DFT-s-OFDM PI/2 BPSK	1@1	14.44	14.29	0.0269
48	30	40	645332	3679.98	DFT-s-OFDM PI/2 BPSK	1@104	14.44	14.29	0.0269
48	30	40	645332	3679.98	DFT-s-OFDM QPSK	50@25	14.46	14.31	0.0270
48	30	40	645332	3679.98	DFT-s-OFDM QPSK	1@1	14.37	14.22	0.0264
48	30	40	645332	3679.98	DFT-s-OFDM QPSK	1@104	14.41	14.26	0.0267
48	30	40	645332	3679.98	DFT-s-OFDM 16 QAM	50@25	13.94	13.79	0.0239
48	30	40	645332	3679.98	DFT-s-OFDM 16 QAM	1@1	13.97	13.82	0.0241
48	30	40	645332	3679.98	DFT-s-OFDM 16 QAM	1@104	13.98	13.83	0.0242
48	30	40	645332	3679.98	DFT-s-OFDM 64 QAM	50@25	13.91	13.76	0.0238
48	30	40	645332	3679.98	DFT-s-OFDM 64 QAM	1@1	13.82	13.67	0.0233
48	30	40	645332	3679.98	DFT-s-OFDM 64 QAM	1@104	13.86	13.71	0.0235
48	30	40	645332	3679.98	DFT-s-OFDM 256 QAM	50@25	13.91	13.76	0.0238
48	30	40	645332	3679.98	DFT-s-OFDM 256 QAM	1@1	13.86	13.71	0.0235
48	30	40	645332	3679.98	DFT-s-OFDM 256 QAM	1@104	13.83	13.68	0.0233
48	30	40	645332	3679.98	CP-OFDM QPSK	53@26	13.45	13.3	0.0214
48	30	40	645332	3679.98	CP-OFDM QPSK	1@1	13.39	13.24	0.0211
48	30	40	645332	3679.98	CP-OFDM QPSK	1@104	13.43	13.28	0.0213
48	30	30	637668	3565.02	DFT-s-OFDM PI/2 BPSK	1@1	14.43	14.28	0.0268
48	30	30	637668	3565.02	DFT-s-OFDM QPSK	1@1	14.38	14.23	0.0265
48	30	30	637668	3565.02	DFT-s-OFDM 16 QAM	1@1	14.01	13.86	0.0243
48	30	30	641666	3624.99	DFT-s-OFDM PI/2 BPSK	1@1	21.19	21.04	0.1271
48	30	30	641666	3624.99	DFT-s-OFDM QPSK	1@1	21.19	21.04	0.1271
48	30	30	641666	3624.99	DFT-s-OFDM 16 QAM	1@1	21.14	20.99	0.1256
48	30	30	645666	3684.99	DFT-s-OFDM PI/2 BPSK	1@1	14.47	14.32	0.0270
48	30	30	645666	3684.99	DFT-s-OFDM QPSK	1@1	14.46	14.31	0.0270
48	30	30	645666	3684.99	DFT-s-OFDM 16 QAM	1@1	14.05	13.9	0.0245
48	30	20	637334	3560.01	DFT-s-OFDM PI/2 BPSK	1@1	20.78	20.63	0.1156
48	30	20	637334	3560.01	DFT-s-OFDM QPSK	1@1	20.68	20.53	0.1130
48	30	20	637334	3560.01	DFT-s-OFDM 16 QAM	1@1	19.71	19.56	0.0904
48	30	20	641666	3624.99	DFT-s-OFDM PI/2 BPSK	1@1	21.4	21.25	0.1334
48	30	20	641666	3624.99	DFT-s-OFDM QPSK	1@1	21.3	21.15	0.1303

48	30	20	641666	3624.99	DFT-s-OFDM 16 QAM	1@1	21.3	21.15	0.1303
48	30	20	646000	3690	DFT-s-OFDM PI/2 BPSK	1@1	21.19	21.04	0.1271
48	30	20	646000	3690	DFT-s-OFDM QPSK	1@1	21.18	21.03	0.1268
48	30	20	646000	3690	DFT-s-OFDM 16 QAM	1@1	21.13	20.98	0.1253
48	30	15	637168	3557.52	DFT-s-OFDM PI/2 BPSK	1@1	19.25	19.1	0.0813
48	30	15	637168	3557.52	DFT-s-OFDM QPSK	1@1	19.22	19.07	0.0807
48	30	15	637168	3557.52	DFT-s-OFDM 16 QAM	1@1	18.08	17.93	0.0621
48	30	15	641666	3624.99	DFT-s-OFDM PI/2 BPSK	1@1	23.1	22.95	0.1972
48	30	15	641666	3624.99	DFT-s-OFDM QPSK	1@1	23.1	22.95	0.1972
48	30	15	641666	3624.99	DFT-s-OFDM 16 QAM	1@1	22.06	21.91	0.1552
48	30	15	646166	3692.49	DFT-s-OFDM PI/2 BPSK	1@1	23.12	22.97	0.1982
48	30	15	646166	3692.49	DFT-s-OFDM QPSK	1@1	23.02	22.87	0.1936
48	30	15	646166	3692.49	DFT-s-OFDM 16 QAM	1@1	21.99	21.84	0.1528
48	30	10	637000	3555	DFT-s-OFDM PI/2 BPSK	1@1	23.08	22.93	0.1963
48	30	10	637000	3555	DFT-s-OFDM QPSK	1@1	22.99	22.84	0.1923
48	30	10	637000	3555	DFT-s-OFDM 16 QAM	1@1	21.92	21.77	0.1503
48	30	10	641666	3624.99	DFT-s-OFDM PI/2 BPSK	1@1	23.13	22.98	0.1986
48	30	10	641666	3624.99	DFT-s-OFDM QPSK	1@1	23.1	22.95	0.1972
48	30	10	641666	3624.99	DFT-s-OFDM 16 QAM	1@1	22.05	21.9	0.1549
48	30	10	646332	3694.98	DFT-s-OFDM PI/2 BPSK	1@1	23.1	22.95	0.1972
48	30	10	646332	3694.98	DFT-s-OFDM QPSK	1@1	23.04	22.89	0.1945
48	30	10	646332	3694.98	DFT-s-OFDM 16 QAM	1@1	21.99	21.84	0.1528

Frequency Stability

NR Band	SCS (kHz)	Bandwidth (MHz)	Arfcn	Freq (MHz)	Modulation	RB	Deviation (ppm)	Verdict	Environment
48	30	20	641666	3624.99	DFT-s-OFDM QPSK	100@0	0.00016	PASS	NV
48	30	20	641666	3624.99	DFT-s-OFDM QPSK	100@0	-0.00121	PASS	LV
48	30	20	641666	3624.99	DFT-s-OFDM QPSK	100@0	0.00120	PASS	HV
48	30	20	641666	3624.99	DFT-s-OFDM QPSK	100@0	0.00011	PASS	-30°C
48	30	20	641666	3624.99	DFT-s-OFDM QPSK	100@0	0.00028	PASS	-20°C
48	30	20	641666	3624.99	DFT-s-OFDM QPSK	100@0	-0.00024	PASS	-10°C
48	30	20	641666	3624.99	DFT-s-OFDM QPSK	100@0	0.00332	PASS	0°C
48	30	20	641666	3624.99	DFT-s-OFDM QPSK	100@0	0.00246	PASS	10°C
48	30	20	641666	3624.99	DFT-s-OFDM QPSK	100@0	0.00025	PASS	20°C
48	30	20	641666	3624.99	DFT-s-OFDM QPSK	100@0	0.00269	PASS	30°C
48	30	20	641666	3624.99	DFT-s-OFDM QPSK	100@0	0.00254	PASS	40°C
48	30	20	641666	3624.99	DFT-s-OFDM QPSK	100@0	-0.00121	PASS	50°C

Occupied Bandwidth

NR Band	SCS (kHz)	Bandwidth (MHz)	Arfcn	Freq (MHz)	Modulation	RB	OBW (MHz)	26dB BW (MHz)
48	30	10	641666	3624.99	CP-OFDM QPSK	24@0	8.5796	9.773
48	30	10	641666	3624.99	CP-OFDM 16 QAM	24@0	8.5643	9.642
48	30	10	641666	3624.99	CP-OFDM 64 QAM	24@0	8.56	9.349
48	30	10	641666	3624.99	CP-OFDM 256 QAM	24@0	8.5513	9.433
48	30	15	641666	3624.99	CP-OFDM QPSK	38@0	13.58	14.92
48	30	15	641666	3624.99	CP-OFDM 16 QAM	38@0	13.579	14.53
48	30	15	641666	3624.99	CP-OFDM 64 QAM	38@0	13.582	14.83
48	30	15	641666	3624.99	CP-OFDM 256 QAM	38@0	13.578	14.55
48	30	20	641666	3624.99	CP-OFDM QPSK	51@0	18.23	19.24
48	30	20	641666	3624.99	CP-OFDM 16 QAM	51@0	18.231	19.46
48	30	20	641666	3624.99	CP-OFDM 64 QAM	51@0	18.162	19.24
48	30	20	641666	3624.99	CP-OFDM 256 QAM	51@0	18.145	19.29
48	30	30	641666	3624.99	CP-OFDM QPSK	78@0	27.831	29.23
48	30	30	641666	3624.99	CP-OFDM 16 QAM	78@0	27.78	29.8
48	30	30	641666	3624.99	CP-OFDM 64 QAM	78@0	27.91	29.29
48	30	30	641666	3624.99	CP-OFDM 256 QAM	78@0	27.849	29.14
48	30	40	641666	3624.99	CP-OFDM QPSK	106@0	37.899	39.6
48	30	40	641666	3624.99	CP-OFDM 16 QAM	106@0	37.79	39.4
48	30	40	641666	3624.99	CP-OFDM 64 QAM	106@0	37.83	39.23
48	30	40	641666	3624.99	CP-OFDM 256 QAM	106@0	37.797	39.53

N48(10M)_CP-OFDM_QPSK_Outer_Full_Mid_CH



N48(10M)_CP-OFDM_16QAM_Outer_Full_Mid_CH

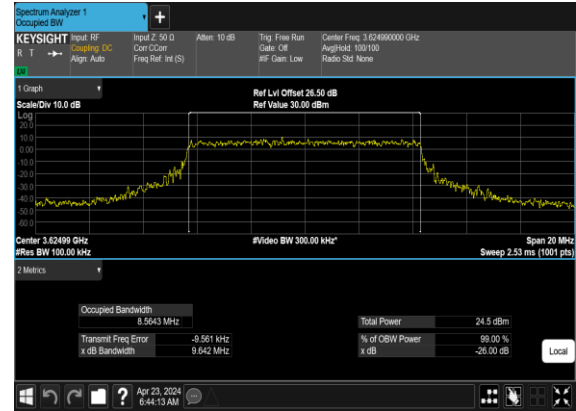

N48(10M)_CP-OFDM_64QAM_Outer_Full_Mid_CH

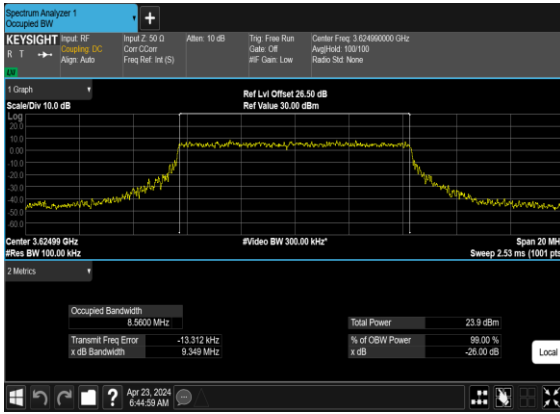

N48(10M)_CP-OFDM_256QAM_Outer_Full_Mid_CH

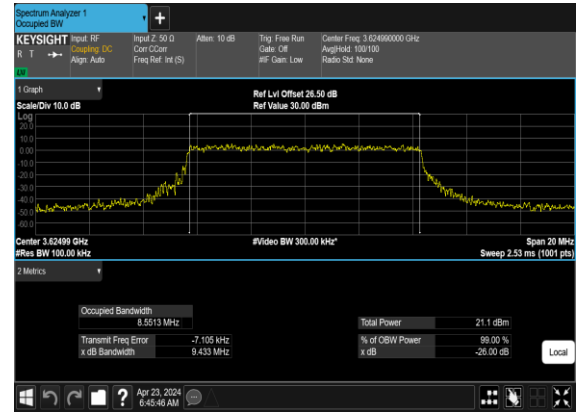

N48(15M)_CP-OFDM_QPSK_Outer_Full_Mid_CH

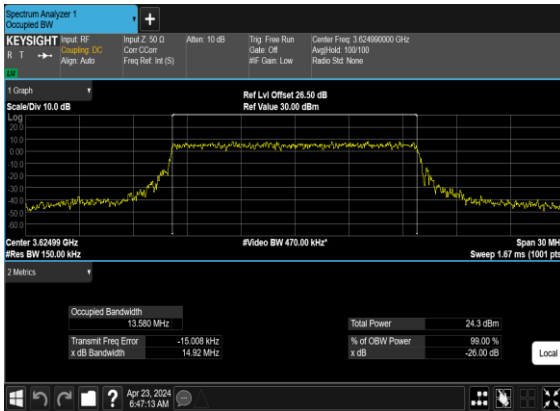

N48(15M)_CP-OFDM_16QAM_Outer_Full_Mid_CH

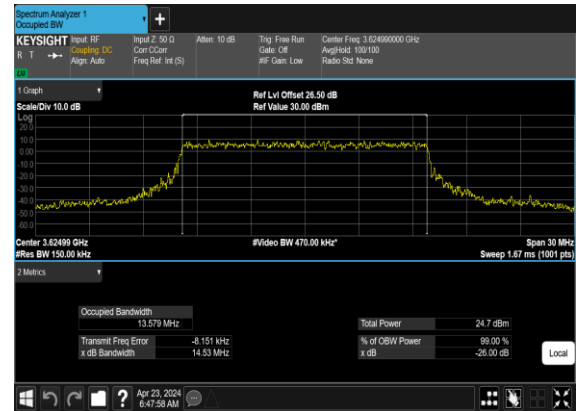

N48(15M)_CP-OFDM_64
QAM_Outer_Full_Mid_CH

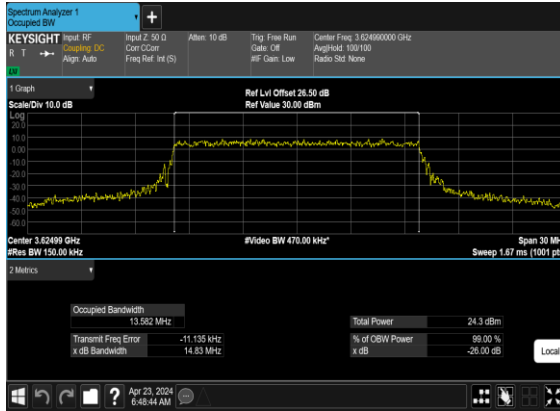

N48(15M)_CP-OFDM_256
QAM_Outer_Full_Mid_CH

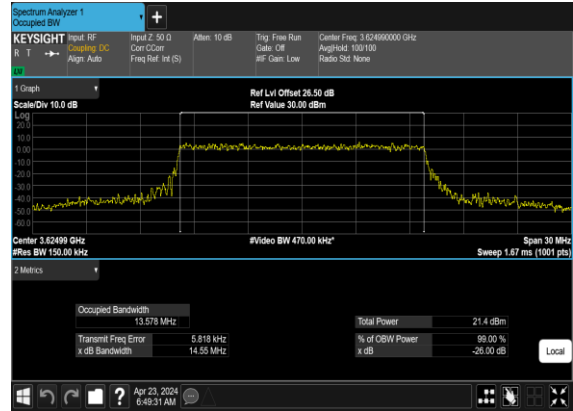

N48(20M)_CP-
OFDM_QPSK_Outer_Full_Mid_CH

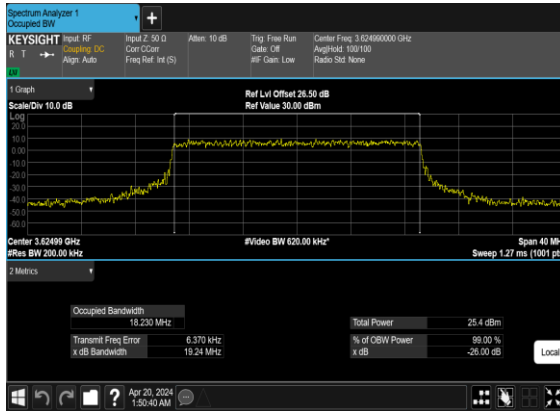

N48(20M)_CP-OFDM_16
QAM_Outer_Full_Mid_CH

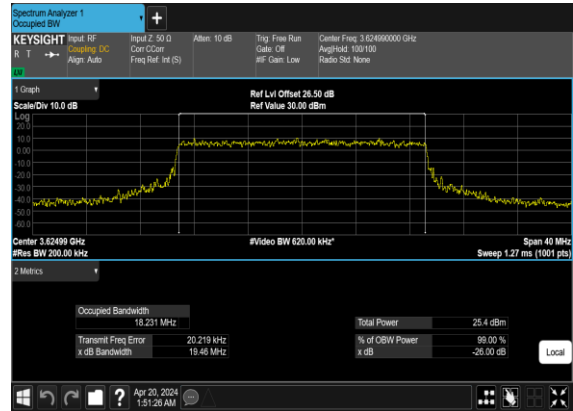

N48(20M)_CP-OFDM_64
QAM_Outer_Full_Mid_CH

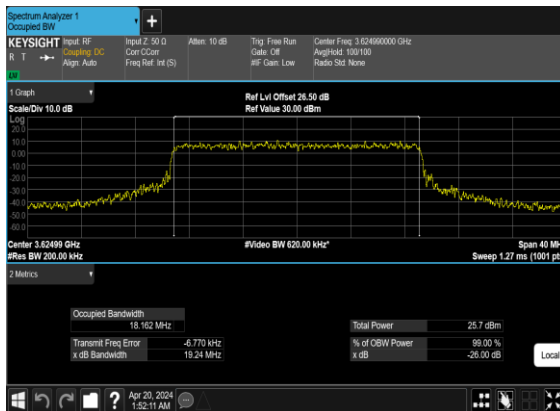

N48(20M)_CP-OFDM_256
QAM_Outer_Full_Mid_CH

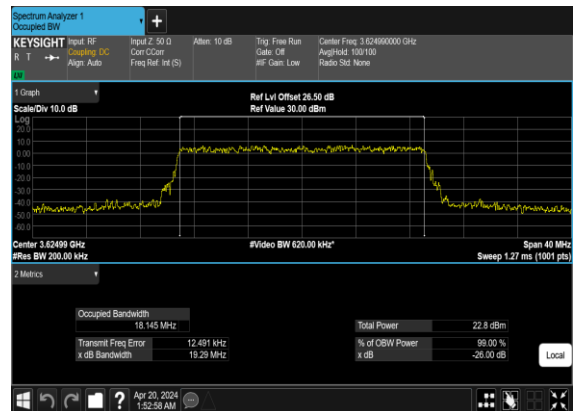

N48(30M)_CP-OFDM_QPSK_Outer_Full_Mid_CH



N48(30M)_CP-OFDM_16QAM_Outer_Full_Mid_CH

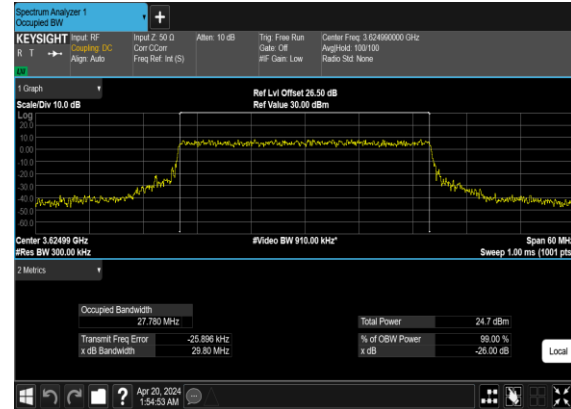

N48(30M)_CP-OFDM_64QAM_Outer_Full_Mid_CH

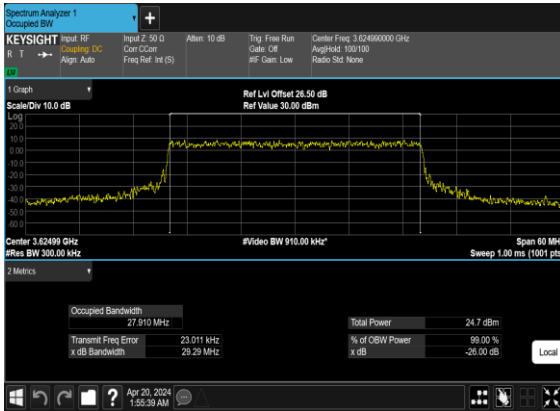

N48(30M)_CP-OFDM_256QAM_Outer_Full_Mid_CH

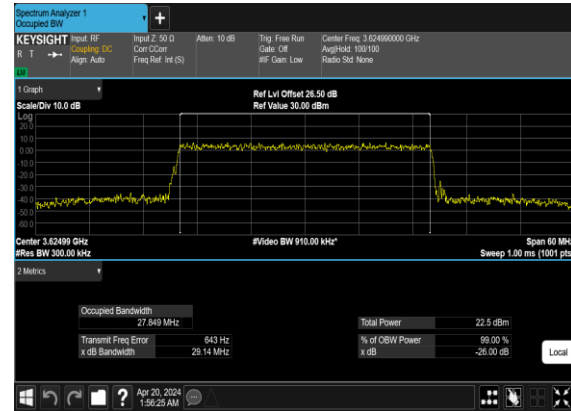

N48(40M)_CP-OFDM_QPSK_Outer_Full_Mid_CH

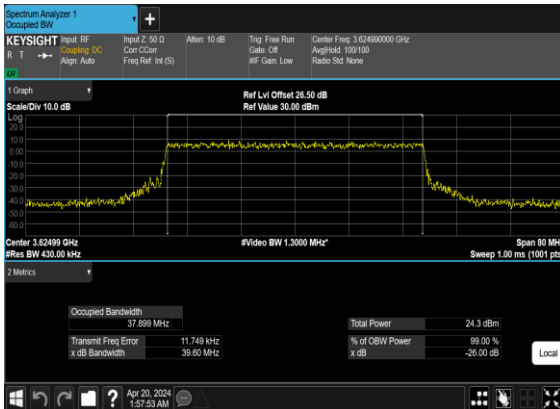

N48(40M)_CP-OFDM_16QAM_Outer_Full_Mid_CH

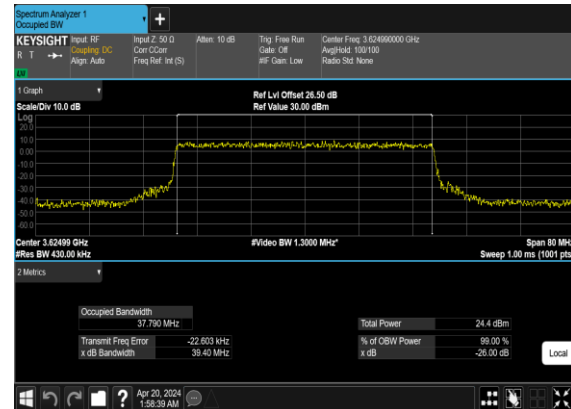

N48(40M)_CP-OFDM_64 QAM_Outer_Full_Mid_CH



N48(40M)_CP-OFDM_256 QAM_Outer_Full_Mid_CH

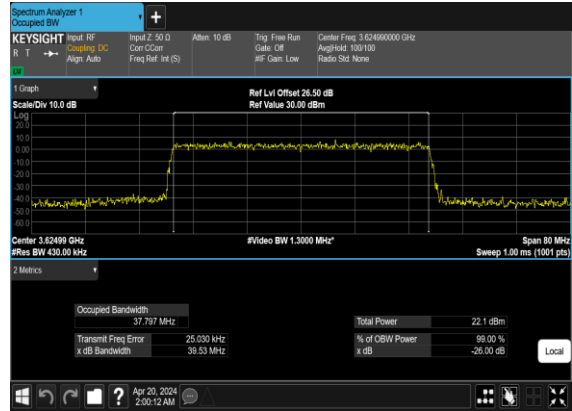

Conducted Spurious Emissions

NR Band	SCS (kHz)	Bandwidth (MHz)	Arfcn	Freq (MHz)	Modulation	RB	Result	Verdict
48	30	10	637000	3555.0	DFT-s-OFDM BPSK	1@0	see graph	---
48	30	10	637000	3555.0	DFT-s-OFDM BPSK	1@0	see graph	PASS
48	30	10	637000	3555.0	DFT-s-OFDM BPSK	1@0	see graph	PASS
48	30	10	637000	3555.0	DFT-s-OFDM QPSK	1@0	see graph	---
48	30	10	637000	3555.0	DFT-s-OFDM QPSK	1@0	see graph	PASS
48	30	10	637000	3555.0	DFT-s-OFDM QPSK	1@0	see graph	PASS
48	30	10	641666	3624.99	DFT-s-OFDM BPSK	1@0	see graph	---
48	30	10	641666	3624.99	DFT-s-OFDM BPSK	1@0	see graph	PASS
48	30	10	641666	3624.99	DFT-s-OFDM BPSK	1@0	see graph	PASS
48	30	10	641666	3624.99	DFT-s-OFDM QPSK	1@0	see graph	---
48	30	10	641666	3624.99	DFT-s-OFDM QPSK	1@0	see graph	PASS
48	30	10	641666	3624.99	DFT-s-OFDM QPSK	1@0	see graph	PASS
48	30	10	646332	3694.98	DFT-s-OFDM BPSK	1@0	see graph	---
48	30	10	646332	3694.98	DFT-s-OFDM BPSK	1@0	see graph	PASS
48	30	10	646332	3694.98	DFT-s-OFDM BPSK	1@0	see graph	PASS
48	30	10	646332	3694.98	DFT-s-OFDM QPSK	1@0	see graph	---
48	30	10	646332	3694.98	DFT-s-OFDM QPSK	1@0	see graph	PASS
48	30	10	646332	3694.98	DFT-s-OFDM QPSK	1@0	see graph	PASS
48	30	20	637334	3560.01	DFT-s-OFDM BPSK	1@0	see graph	---
48	30	20	637334	3560.01	DFT-s-OFDM BPSK	1@0	see graph	PASS
48	30	20	637334	3560.01	DFT-s-OFDM BPSK	1@0	see graph	PASS
48	30	20	637334	3560.01	DFT-s-OFDM QPSK	1@0	see graph	---
48	30	20	637334	3560.01	DFT-s-OFDM QPSK	1@0	see graph	PASS
48	30	20	637334	3560.01	DFT-s-OFDM QPSK	1@0	see graph	PASS
48	30	20	641666	3624.99	DFT-s-OFDM BPSK	1@0	see graph	---
48	30	20	641666	3624.99	DFT-s-OFDM BPSK	1@0	see graph	PASS
48	30	20	641666	3624.99	DFT-s-OFDM BPSK	1@0	see graph	PASS
48	30	20	641666	3624.99	DFT-s-OFDM QPSK	1@0	see graph	---
48	30	20	641666	3624.99	DFT-s-OFDM QPSK	1@0	see graph	PASS
48	30	20	641666	3624.99	DFT-s-OFDM QPSK	1@0	see graph	PASS
48	30	20	646000	3690.0	DFT-s-OFDM BPSK	1@0	see graph	---
48	30	20	646000	3690.0	DFT-s-OFDM BPSK	1@0	see graph	PASS
48	30	20	646000	3690.0	DFT-s-OFDM BPSK	1@0	see graph	PASS
48	30	20	646000	3690.0	DFT-s-OFDM QPSK	1@0	see graph	---
48	30	20	646000	3690.0	DFT-s-OFDM QPSK	1@0	see graph	PASS

48	30	20	646000	3690.0	DFT-s-OFDM QPSK	1@0	see graph	PASS
48	30	40	638000	3570.0	DFT-s-OFDM BPSK	1@0	see graph	---
48	30	40	638000	3570.0	DFT-s-OFDM BPSK	1@0	see graph	PASS
48	30	40	638000	3570.0	DFT-s-OFDM BPSK	1@0	see graph	PASS
48	30	40	638000	3570.0	DFT-s-OFDM QPSK	1@0	see graph	---
48	30	40	638000	3570.0	DFT-s-OFDM QPSK	1@0	see graph	PASS
48	30	40	638000	3570.0	DFT-s-OFDM QPSK	1@0	see graph	PASS
48	30	40	641666	3624.99	DFT-s-OFDM BPSK	1@0	see graph	---
48	30	40	641666	3624.99	DFT-s-OFDM BPSK	1@0	see graph	PASS
48	30	40	641666	3624.99	DFT-s-OFDM BPSK	1@0	see graph	PASS
48	30	40	641666	3624.99	DFT-s-OFDM QPSK	1@0	see graph	---
48	30	40	641666	3624.99	DFT-s-OFDM QPSK	1@0	see graph	PASS
48	30	40	641666	3624.99	DFT-s-OFDM QPSK	1@0	see graph	PASS
48	30	40	645332	3679.98	DFT-s-OFDM BPSK	1@0	see graph	---
48	30	40	645332	3679.98	DFT-s-OFDM BPSK	1@0	see graph	PASS
48	30	40	645332	3679.98	DFT-s-OFDM BPSK	1@0	see graph	PASS
48	30	40	645332	3679.98	DFT-s-OFDM QPSK	1@0	see graph	---
48	30	40	645332	3679.98	DFT-s-OFDM QPSK	1@0	see graph	PASS
48	30	40	645332	3679.98	DFT-s-OFDM QPSK	1@0	see graph	PASS

N48(10M)_DFT-s-OFDM_BPSK_Edge_1RB_Left_Low_CH

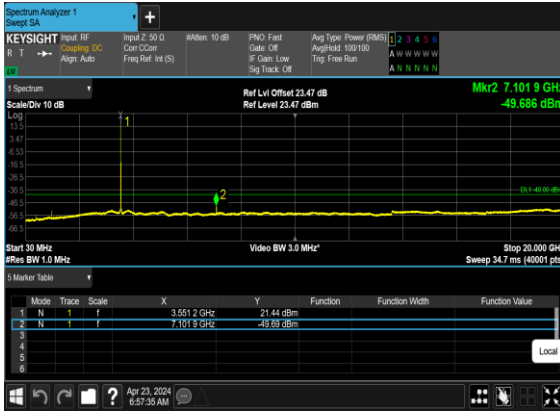

N48(10M)_DFT-s-OFDM_BPSK_Edge_1RB_Left_Low_CH

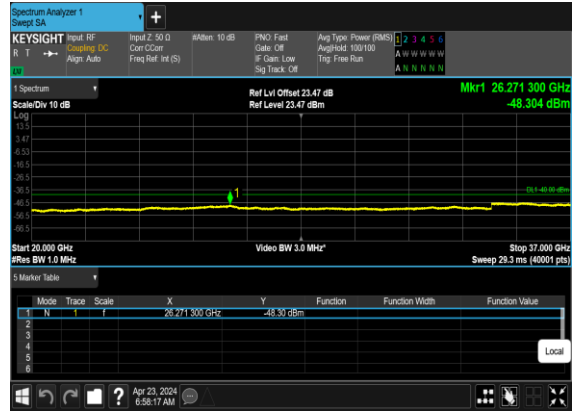

N48(10M)_DFT-s-OFDM_QPSK_Edge_1RB_Left_Low_CH

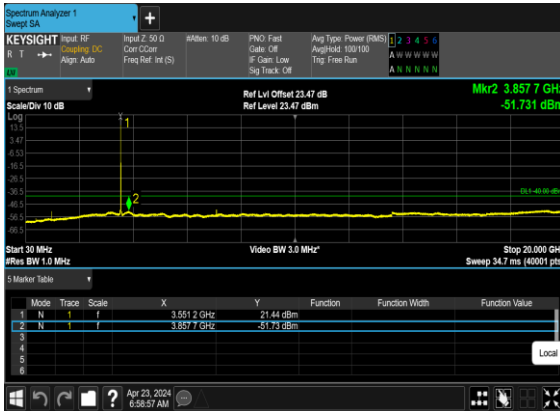

N48(10M)_DFT-s-OFDM_QPSK_Edge_1RB_Left_Low_CH



N48(10M)_DFT-s-OFDM_BPSK_Edge_1RB_Left_Mid_CH

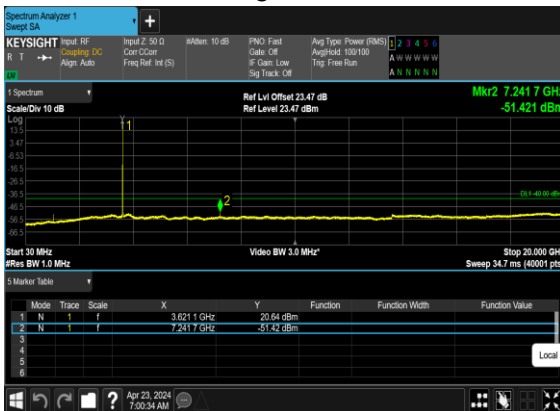

N48(10M)_DFT-s-OFDM_BPSK_Edge_1RB_Left_Mid_CH

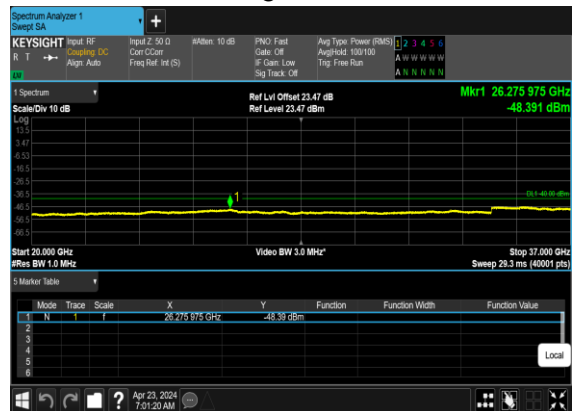

N48(10M)_DFT-s-OFDM_QPSK_Edge_1RB_Left_Mid_CH

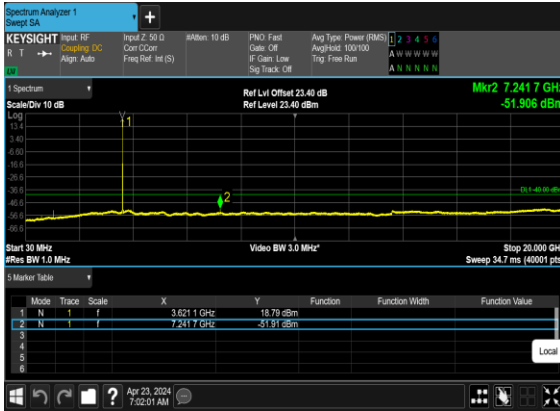

N48(10M)_DFT-s-OFDM_QPSK_Edge_1RB_Left_Mid_CH

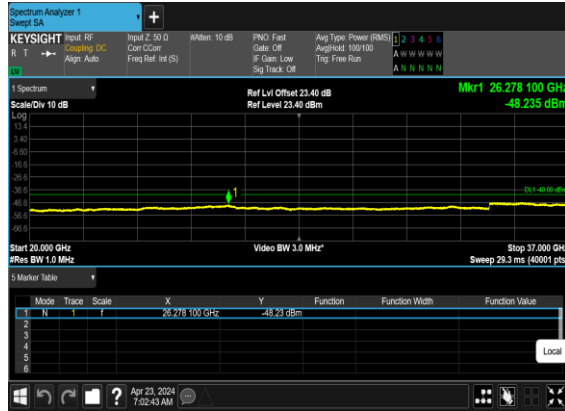

N48(10M)_DFT-s-OFDM_BPSK_Edge_1RB_Left_High_CH

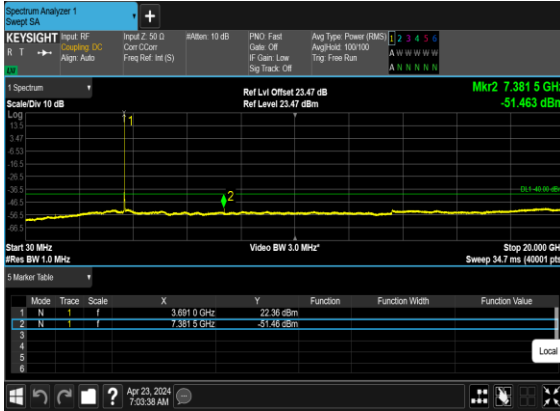

N48(10M)_DFT-s-OFDM_BPSK_Edge_1RB_Left_High_CH

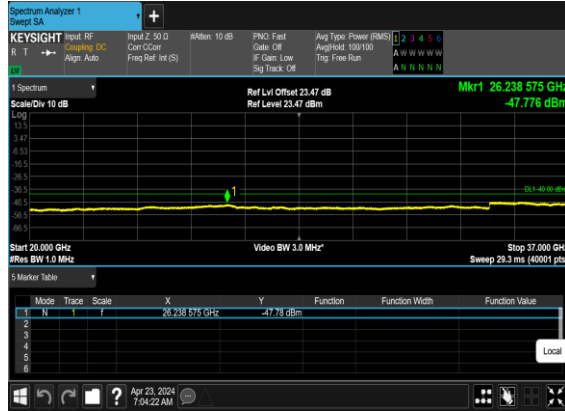

N48(10M)_DFT-s-OFDM_QPSK_Edge_1RB_Left_High_CH



N48(10M)_DFT-s-OFDM_QPSK_Edge_1RB_Left_High_CH

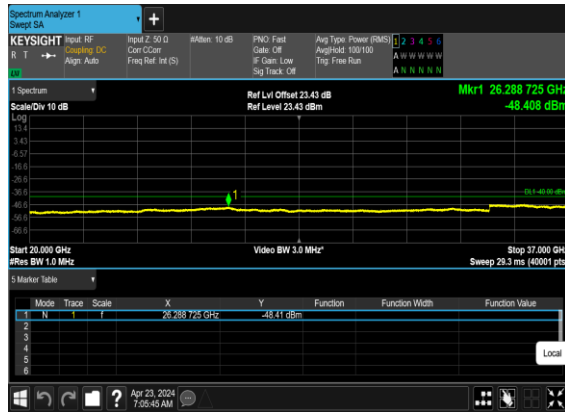

N48(20M)_DFT-s-OFDM_BPSK_Edge_1RB_Left_Low_CH

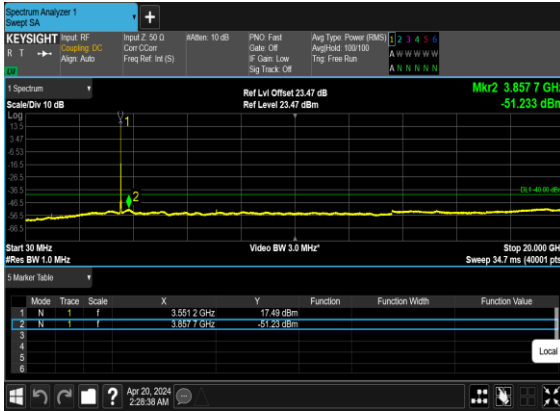

N48(20M)_DFT-s-OFDM_BPSK_Edge_1RB_Left_Low_CH

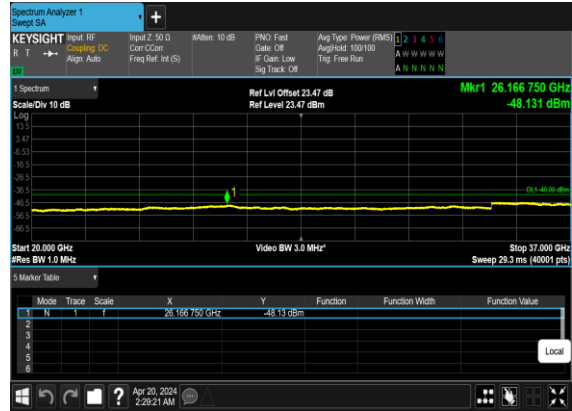

N48(20M)_DFT-s-OFDM_QPSK_Edge_1RB_Left_Low_CH

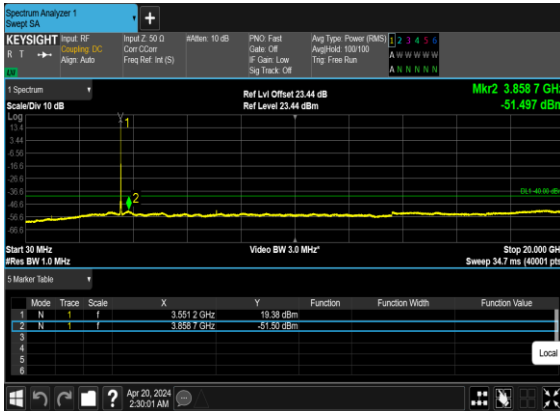

N48(20M)_DFT-s-OFDM_QPSK_Edge_1RB_Left_Low_CH



N48(20M)_DFT-s-OFDM_BPSK_Edge_1RB_Left_Mid_CH

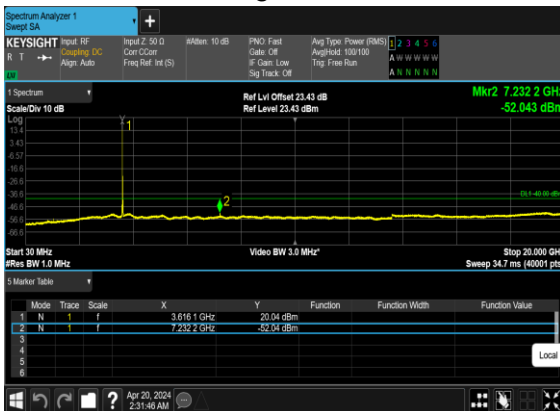

N48(20M)_DFT-s-OFDM_BPSK_Edge_1RB_Left_Mid_CH

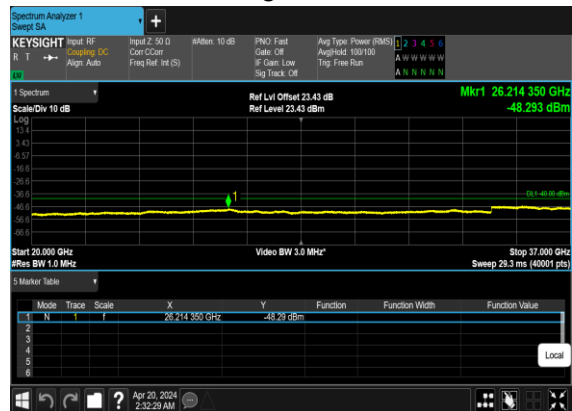

N48(20M)_DFT-s-OFDM_QPSK_Edge_1RB_Left_Mid_CH

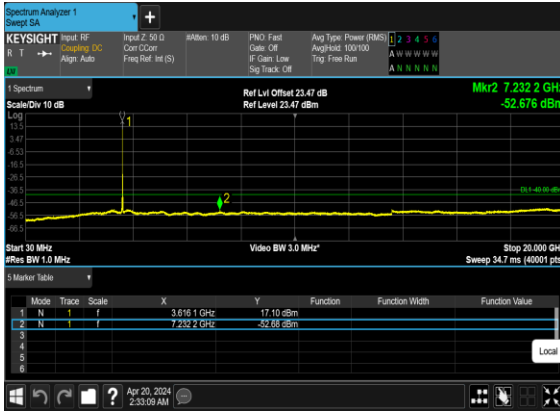

N48(20M)_DFT-s-OFDM_QPSK_Edge_1RB_Left_Mid_CH

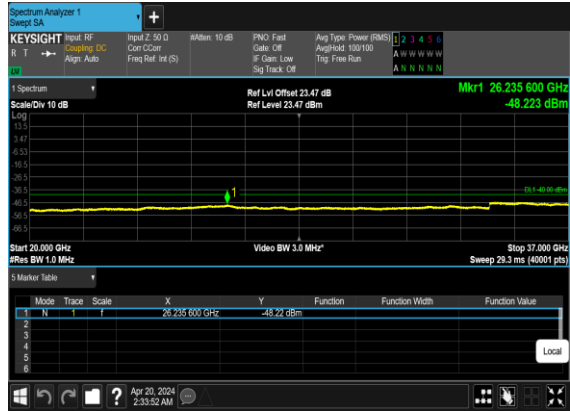

N48(20M)_DFT-s-OFDM_BPSK_Edge_1RB_Left_High_CH

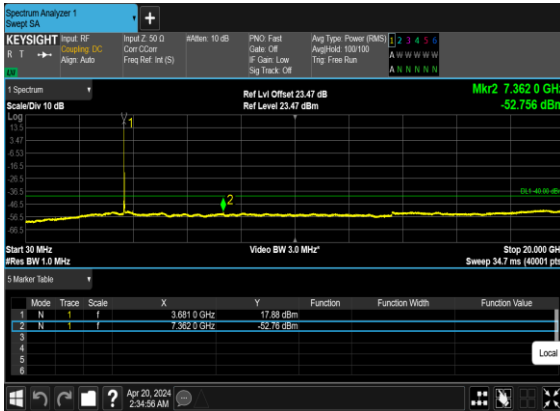

N48(20M)_DFT-s-OFDM_BPSK_Edge_1RB_Left_High_CH



N48(20M)_DFT-s-OFDM_QPSK_Edge_1RB_Left_High_CH

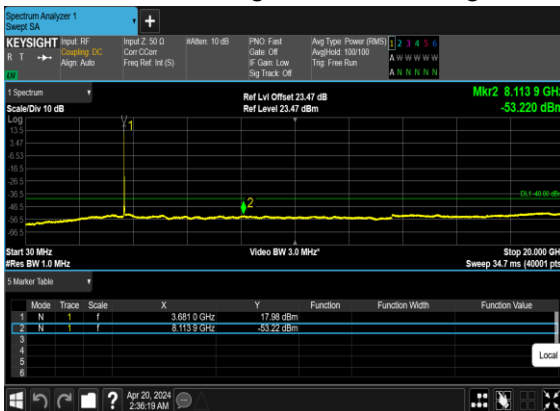

N48(20M)_DFT-s-OFDM_QPSK_Edge_1RB_Left_High_CH

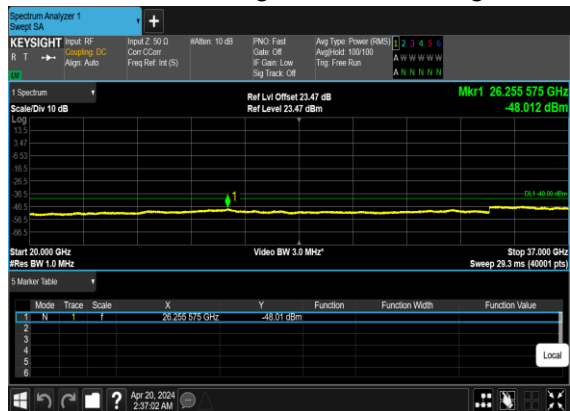

N48(40M)_DFT-s-OFDM_BPSK_Edge_1RB_Left_Low_CH

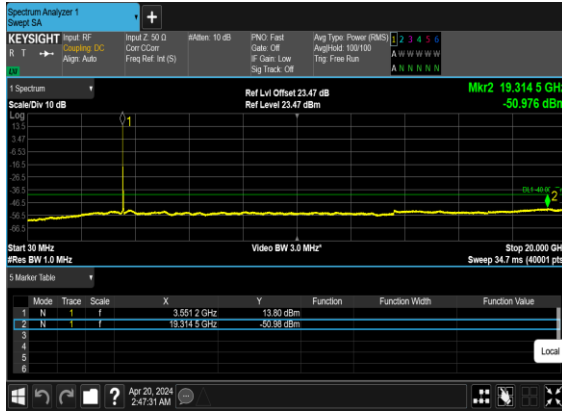

N48(40M)_DFT-s-OFDM_BPSK_Edge_1RB_Left_Low_CH

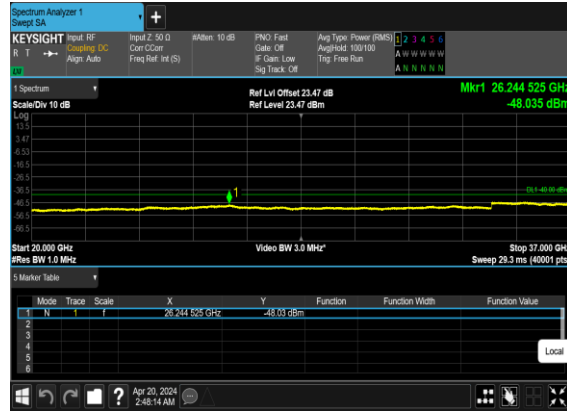

N48(40M)_DFT-s-OFDM_QPSK_Edge_1RB_Left_Low_CH

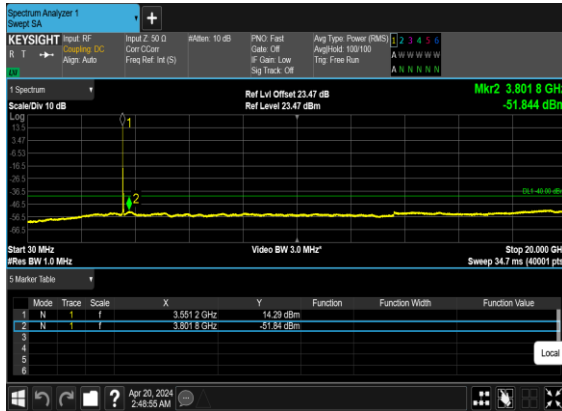

N48(40M)_DFT-s-OFDM_QPSK_Edge_1RB_Left_Low_CH



N48(40M)_DFT-s-OFDM_BPSK_Edge_1RB_Left_Mid_CH

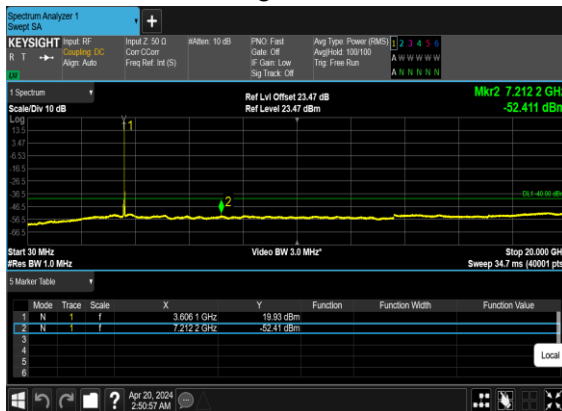

N48(40M)_DFT-s-OFDM_BPSK_Edge_1RB_Left_Mid_CH

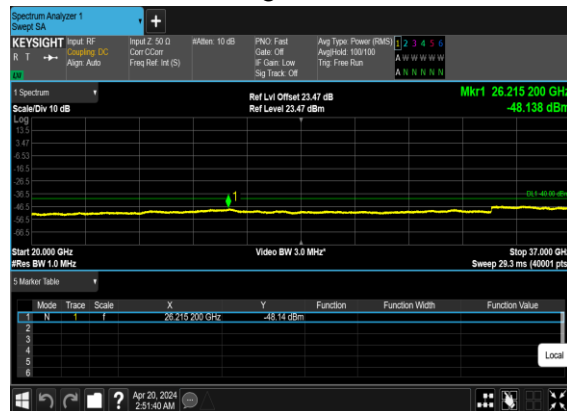

N48(40M)_DFT-s-OFDM_QPSK_Edge_1RB_Left_Mid_CH



N48(40M)_DFT-s-OFDM_QPSK_Edge_1RB_Left_Mid_CH

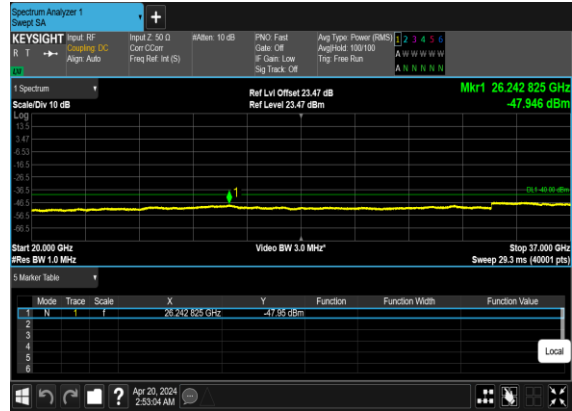

N48(40M)_DFT-s-OFDM_BPSK_Edge_1RB_Left_High_CH



N48(40M)_DFT-s-OFDM_BPSK_Edge_1RB_Left_High_CH

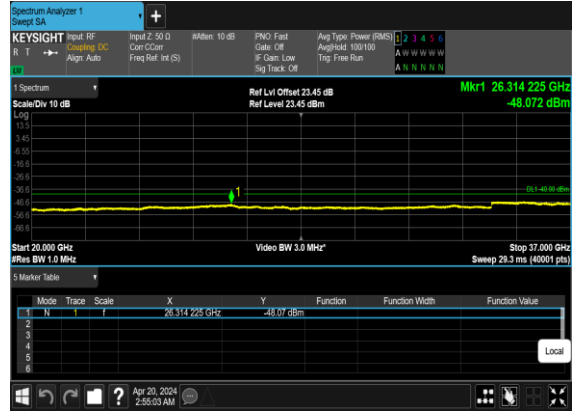

N48(40M)_DFT-s-OFDM_QPSK_Edge_1RB_Left_High_CH

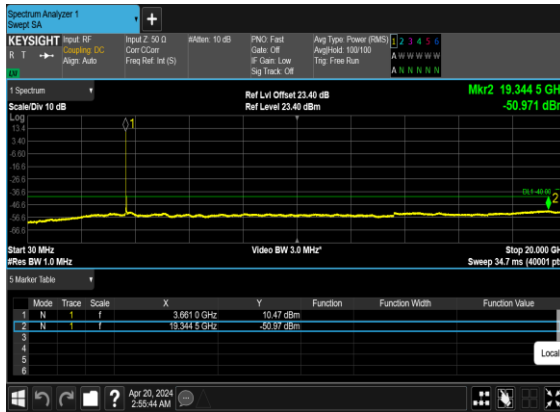

N48(40M)_DFT-s-OFDM_QPSK_Edge_1RB_Left_High_CH



Conducted Band Edge

NR Band	SCS (kHz)	Bandwidth (MHz)	Arfcn	Freq (MHz)	Modulation	RB	Result	Verdict
48	30	10	637000	3555.0	DFT-s-OFDM BPSK	1@0	see graph	PASS
48	30	10	637000	3555.0	DFT-s-OFDM QPSK	1@0	see graph	PASS
48	30	10	637000	3555.0	DFT-s-OFDM BPSK	1@23	see graph	PASS
48	30	10	637000	3555.0	DFT-s-OFDM QPSK	1@23	see graph	PASS
48	30	10	637000	3555.0	DFT-s-OFDM BPSK	24@0	see graph	PASS
48	30	10	637000	3555.0	DFT-s-OFDM QPSK	24@0	see graph	PASS
48	30	10	641666	3624.99	DFT-s-OFDM BPSK	1@0	see graph	PASS
48	30	10	641666	3624.99	DFT-s-OFDM QPSK	1@0	see graph	PASS
48	30	10	641666	3624.99	DFT-s-OFDM BPSK	1@23	see graph	PASS
48	30	10	641666	3624.99	DFT-s-OFDM QPSK	1@23	see graph	PASS
48	30	10	641666	3624.99	DFT-s-OFDM BPSK	24@0	see graph	PASS
48	30	10	641666	3624.99	DFT-s-OFDM QPSK	24@0	see graph	PASS
48	30	10	646332	3694.98	DFT-s-OFDM BPSK	1@0	see graph	PASS
48	30	10	646332	3694.98	DFT-s-OFDM QPSK	1@0	see graph	PASS
48	30	10	646332	3694.98	DFT-s-OFDM BPSK	1@23	see graph	PASS
48	30	10	646332	3694.98	DFT-s-OFDM QPSK	1@23	see graph	PASS
48	30	10	646332	3694.98	DFT-s-OFDM BPSK	24@0	see graph	PASS
48	30	10	646332	3694.98	DFT-s-OFDM QPSK	24@0	see graph	PASS
48	30	20	637334	3560.01	DFT-s-OFDM BPSK	1@0	see graph	PASS
48	30	20	637334	3560.01	DFT-s-OFDM QPSK	1@0	see graph	PASS
48	30	20	637334	3560.01	DFT-s-OFDM BPSK	1@50	see graph	PASS
48	30	20	637334	3560.01	DFT-s-OFDM QPSK	1@50	see graph	PASS
48	30	20	637334	3560.01	DFT-s-OFDM BPSK	50@0	see graph	PASS
48	30	20	637334	3560.01	DFT-s-OFDM QPSK	50@0	see graph	PASS
48	30	20	641666	3624.99	DFT-s-OFDM BPSK	1@0	see graph	PASS
48	30	20	641666	3624.99	DFT-s-OFDM QPSK	1@0	see graph	PASS
48	30	20	641666	3624.99	DFT-s-OFDM BPSK	1@50	see graph	PASS
48	30	20	641666	3624.99	DFT-s-OFDM QPSK	1@50	see graph	PASS
48	30	20	641666	3624.99	DFT-s-OFDM BPSK	50@0	see graph	PASS
48	30	20	641666	3624.99	DFT-s-OFDM QPSK	50@0	see graph	PASS
48	30	20	646000	3690.0	DFT-s-OFDM BPSK	1@0	see graph	PASS
48	30	20	646000	3690.0	DFT-s-OFDM QPSK	1@0	see graph	PASS
48	30	20	646000	3690.0	DFT-s-OFDM BPSK	1@50	see graph	PASS
48	30	20	646000	3690.0	DFT-s-OFDM QPSK	1@50	see graph	PASS
48	30	20	646000	3690.0	DFT-s-OFDM BPSK	50@0	see graph	PASS

48	30	20	646000	3690.0	DFT-s-OFDM QPSK	50@0	see graph	PASS
48	30	40	638000	3570.0	DFT-s-OFDM BPSK	1@0	see graph	PASS
48	30	40	638000	3570.0	DFT-s-OFDM QPSK	1@0	see graph	PASS
48	30	40	638000	3570.0	DFT-s-OFDM BPSK	1@105	see graph	PASS
48	30	40	638000	3570.0	DFT-s-OFDM QPSK	1@105	see graph	PASS
48	30	40	638000	3570.0	DFT-s-OFDM BPSK	100@0	see graph	PASS
48	30	40	638000	3570.0	DFT-s-OFDM QPSK	100@0	see graph	PASS
48	30	40	641666	3624.99	DFT-s-OFDM BPSK	1@0	see graph	PASS
48	30	40	641666	3624.99	DFT-s-OFDM QPSK	1@0	see graph	PASS
48	30	40	641666	3624.99	DFT-s-OFDM BPSK	1@105	see graph	PASS
48	30	40	641666	3624.99	DFT-s-OFDM QPSK	1@105	see graph	PASS
48	30	40	641666	3624.99	DFT-s-OFDM BPSK	100@0	see graph	PASS
48	30	40	641666	3624.99	DFT-s-OFDM QPSK	100@0	see graph	PASS
48	30	40	645332	3679.98	DFT-s-OFDM BPSK	1@0	see graph	PASS
48	30	40	645332	3679.98	DFT-s-OFDM QPSK	1@0	see graph	PASS
48	30	40	645332	3679.98	DFT-s-OFDM BPSK	1@105	see graph	PASS
48	30	40	645332	3679.98	DFT-s-OFDM QPSK	1@105	see graph	PASS
48	30	40	645332	3679.98	DFT-s-OFDM BPSK	100@0	see graph	PASS
48	30	40	645332	3679.98	DFT-s-OFDM QPSK	100@0	see graph	PASS

N48(20M)_DFT-s-OFDM_BPSK_Edge_1RB_Left_Low_CH

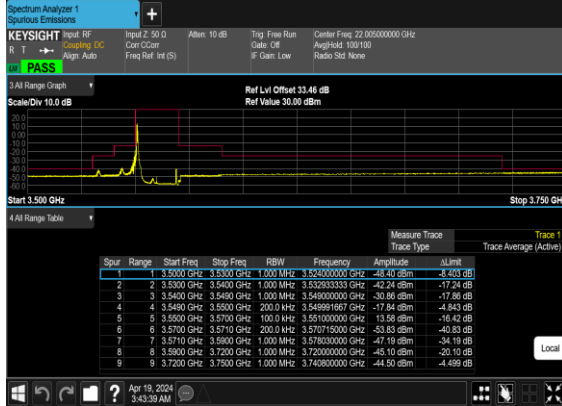

N48(20M)_DFT-s-OFDM_QPSK_Edge_1RB_Left_Low_CH

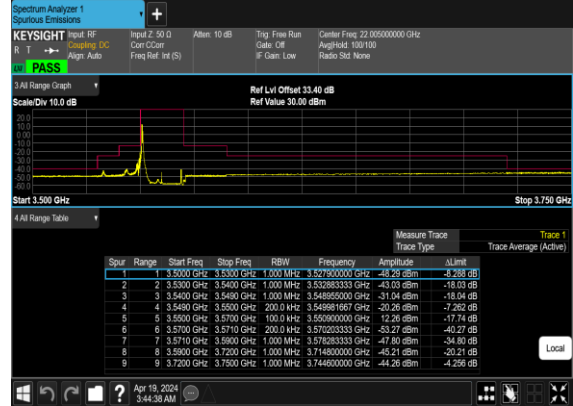

N48(20M)_DFT-s-OFDM_BPSK_Edge_1RB_Right_Low_CH

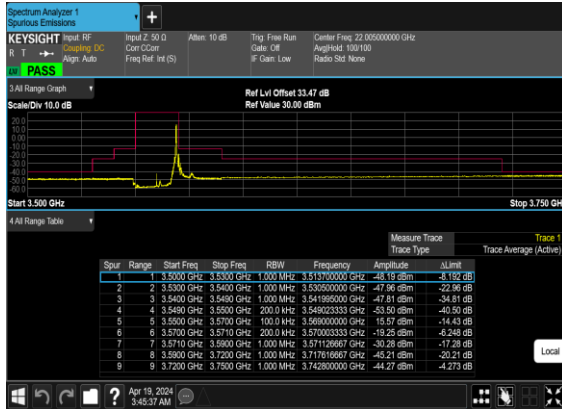

N48(20M)_DFT-s-OFDM_QPSK_Edge_1RB_Right_Low_CH

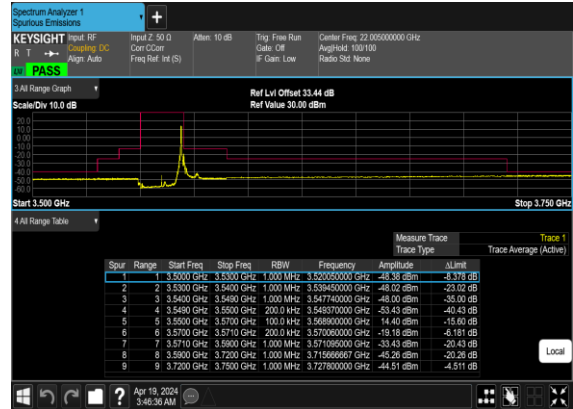

N48(20M)_DFT-s-OFDM_BPSK_Outer_Full_Low_CH

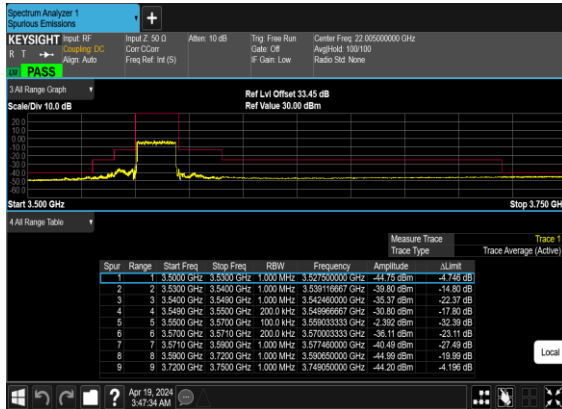

N48(20M)_DFT-s-OFDM_QPSK_Outer_Full_Low_CH

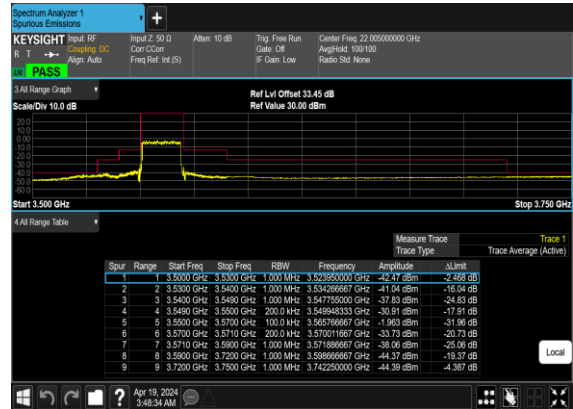

N48(20M)_DFT-s-OFDM_BPSK_Edge_1RB_Left_Mid_CH

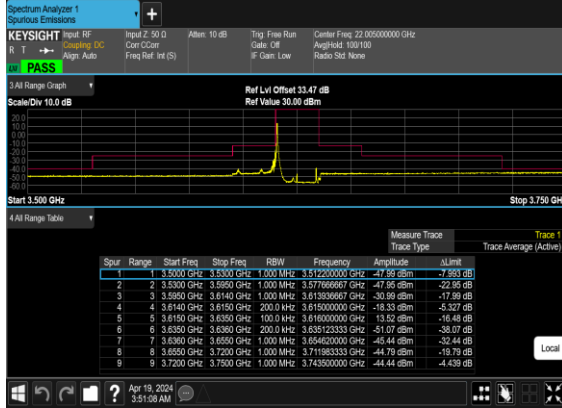

N48(20M)_DFT-s-OFDM_QPSK_Edge_1RB_Left_Mid_CH

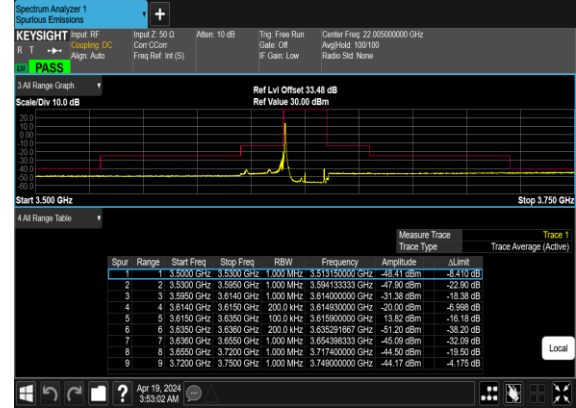

N48(20M)_DFT-s-OFDM_BPSK_Edge_1RB_Right_Mid_CH

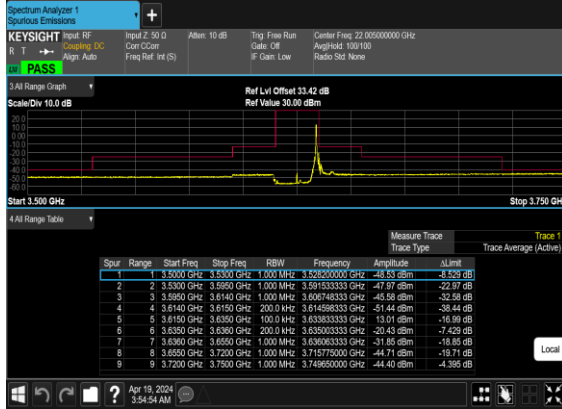

N48(20M)_DFT-s-OFDM_QPSK_Edge_1RB_Right_Mid_CH

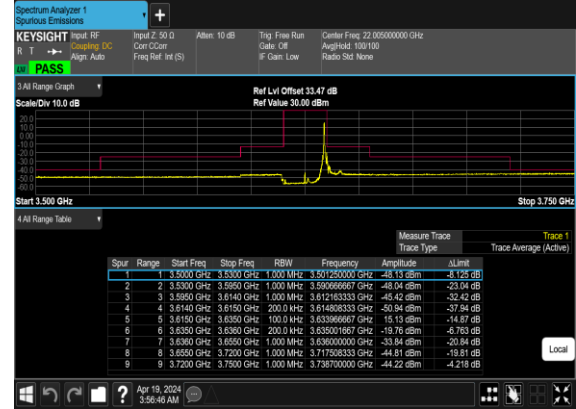

N48(20M)_DFT-s-OFDM_BPSK_Outer_Full_Mid_CH

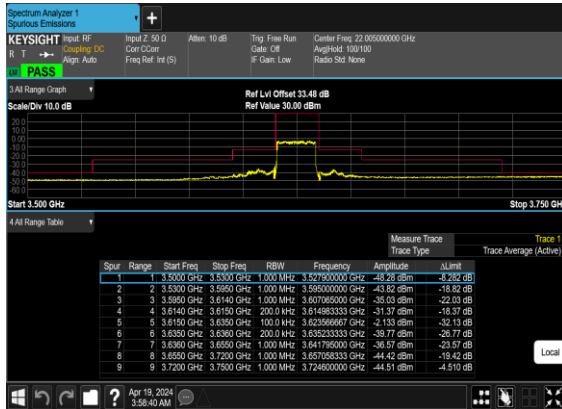

N48(20M)_DFT-s-OFDM_QPSK_Outer_Full_Mid_CH

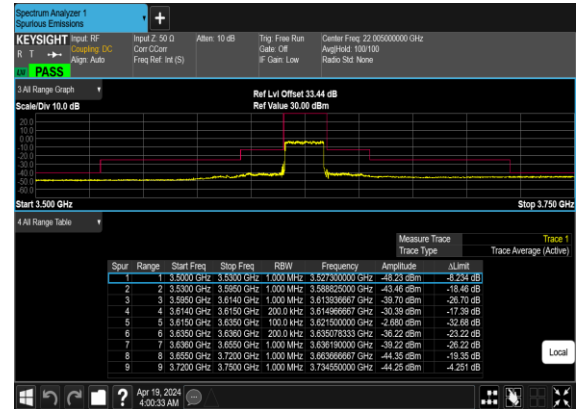

N48(20M)_DFT-s-OFDM_BPSK_Edge_1RB_Left_High_CH

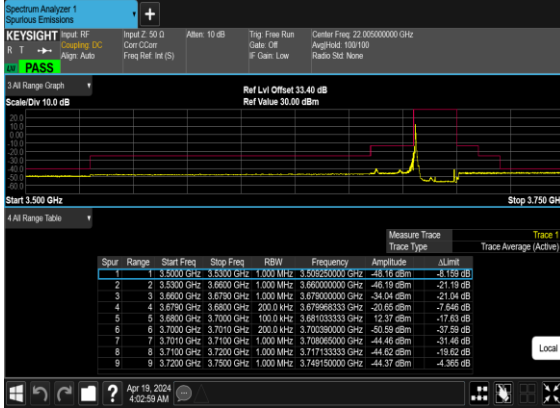

N48(20M)_DFT-s-OFDM_QPSK_Edge_1RB_Left_High_CH

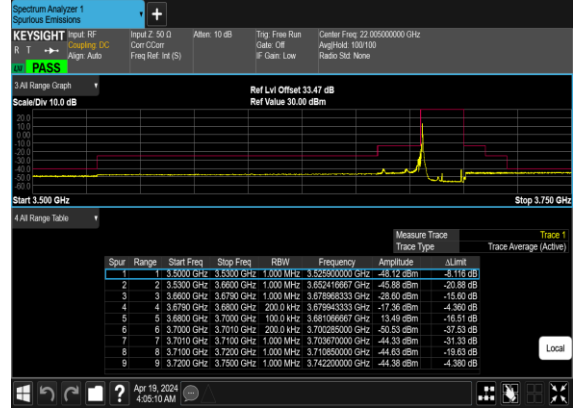

N48(20M)_DFT-s-OFDM_BPSK_Edge_1RB_Right_High_CH

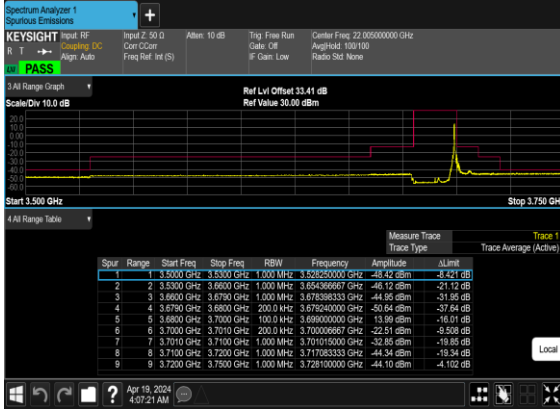

N48(20M)_DFT-s-OFDM_QPSK_Edge_1RB_Right_High_CH

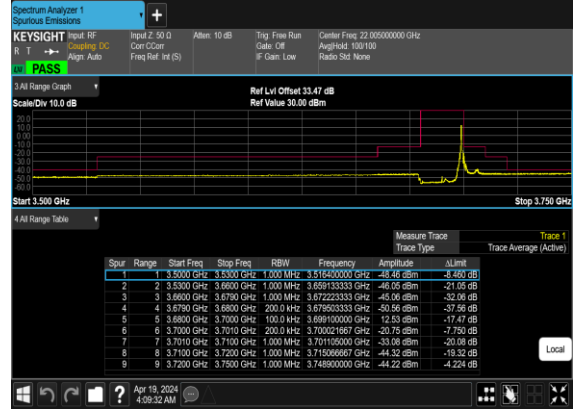

N48(20M)_DFT-s-OFDM_BPSK_Outer_Full_High_CH

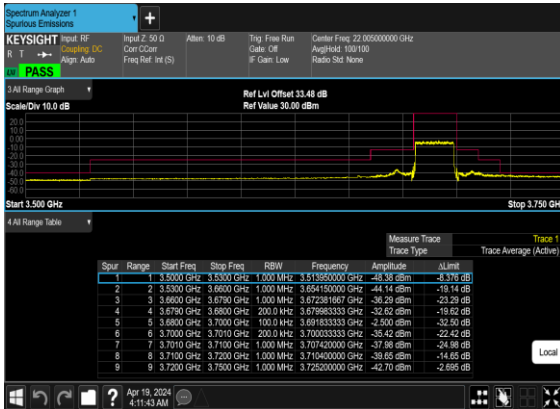

N48(20M)_DFT-s-OFDM_QPSK_Outer_Full_High_CH

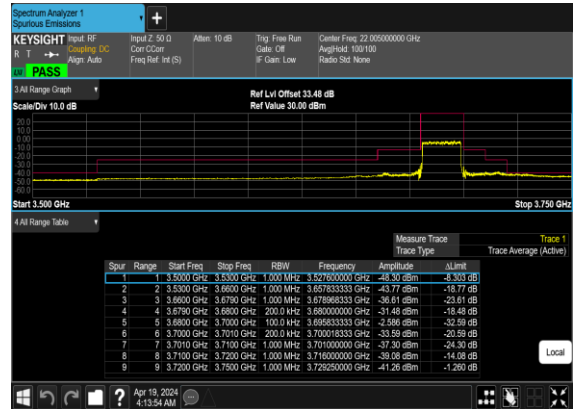

N48(40M)_DFT-s-OFDM_BPSK_Edge_1RB_Left_Low_CH

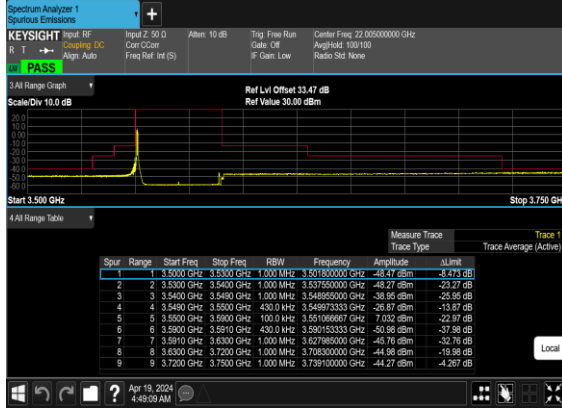

N48(40M)_DFT-s-OFDM_QPSK_Edge_1RB_Left_Low_CH

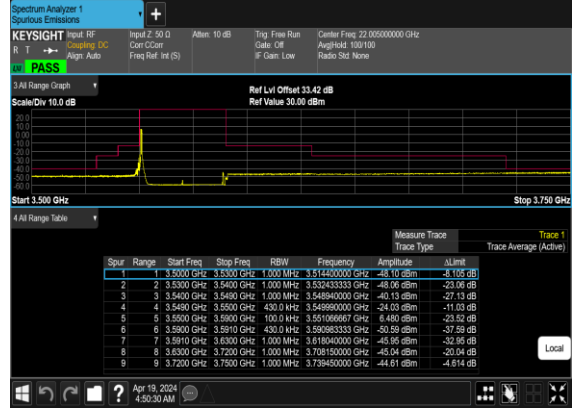

N48(40M)_DFT-s-OFDM_BPSK_Edge_1RB_Right_Low_CH

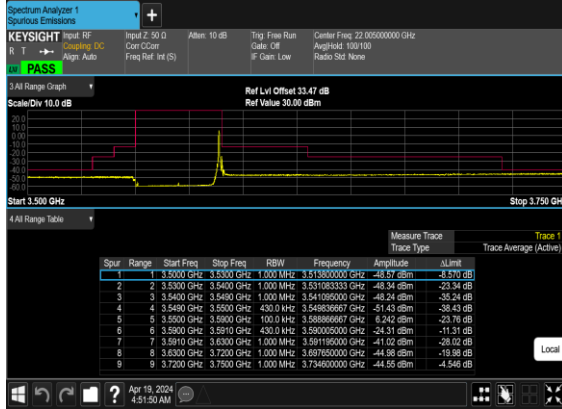

N48(40M)_DFT-s-OFDM_QPSK_Edge_1RB_Right_Low_CH

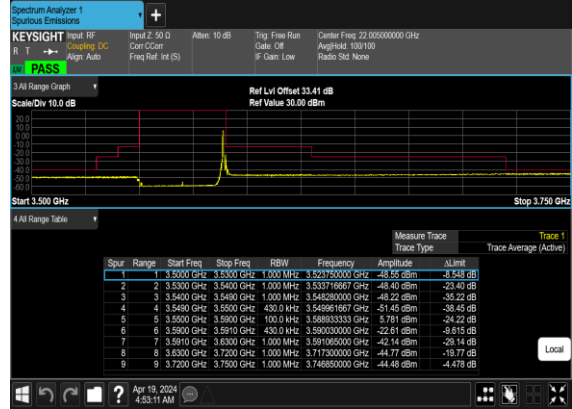

N48(40M)_DFT-s-OFDM_BPSK_Outer_Full_Low_CH

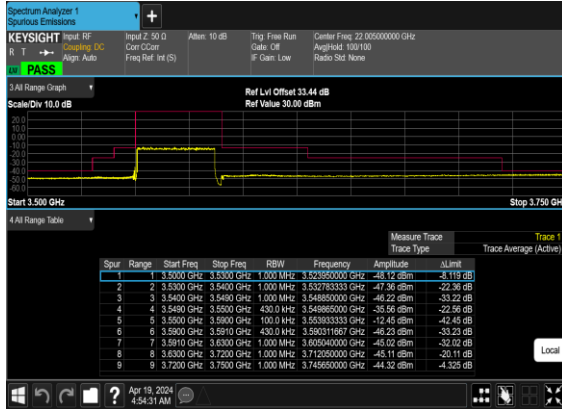

N48(40M)_DFT-s-OFDM_QPSK_Outer_Full_Low_CH

