



FCC RF Test Report

APPLICANT : Xiaomi Communications Co., Ltd.
EQUIPMENT : Mobile Phone
BRAND NAME : Xiaomi
MODEL NAME : 2407FPN8EG
FCC ID : 2AFZZPN8EG
STANDARD : 47 CFR Part 2, 22, 24, 27
CLASSIFICATION : PCS Licensed Transmitter Held to Ear (PCE)
TEST DATE(S) : Apr. 24, 2024 ~ May 15, 2024

We, Sporton International Inc. (ShenZhen), would like to declare that the tested sample has been evaluated in accordance with the procedures given in ANSI C63.26-2015 and shown compliance with the applicable technical standards.

The test results in this report apply exclusively to the tested model / sample. Without written approval of Sporton International Inc. (ShenZhen), the test report shall not be reproduced except in full.

Jason Jia

Approved by: Jason Jia



Sporton International Inc. (ShenZhen)

1/F, 2/F, Bldg 5, Shiling Industrial Zone, Xinwei Village, Xili, Nanshan, Shenzhen, 518055

People's Republic of China



TABLE OF CONTENTS

REVISION HISTORY...3
SUMMARY OF TEST RESULT...4
1 GENERAL DESCRIPTION...5
1.1 Applicant...5
1.2 Manufacturer...5
1.3 Product Feature of Equipment Under Test...5
1.4 Product Specification of Equipment Under Test...5
1.5 Modification of EUT...6
1.6 Maximum ERP/EIRP and Emission Designator...7
1.7 Testing Location...8
1.8 Test Software...8
1.9 Applicable Standards...9
2 TEST CONFIGURATION OF EQUIPMENT UNDER TEST...10
2.1 Test Mode...10
2.2 Connection Diagram of Test System...12
2.3 Support Unit used in test configuration and system...12
2.4 Measurement Results Explanation Example...12
2.5 Frequency List of Low/Middle/High Channels...13
3 CONDUCTED TEST ITEMS...15
3.1 Measuring Instruments...15
3.2 Test Setup...15
3.3 Test Result of Conducted Test...15
3.4 Conducted Output Power and ERP/EIRP...16
3.5 Peak-to-Average Ratio...17
3.6 Occupied Bandwidth...18
3.7 Conducted Band Edge...19
3.8 Conducted Spurious Emission...21
3.9 Frequency Stability...22
4 RADIATED TEST ITEMS...23
4.1 Measuring Instruments...23
4.2 Test Setup...23
4.3 Test Result of Radiated Test...24
4.4 Radiated Spurious Emission...25
5 LIST OF MEASURING EQUIPMENT...26
6 MEASUREMENT UNCERTAINTY...27
APPENDIX A. TEST RESULTS OF CONDUCTED TEST
APPENDIX B. TEST RESULTS OF RADIATED TEST
APPENDIX C. TEST SETUP PHOTOGRAPHS



REVISION HISTORY

REPORT NO.	VERSION	DESCRIPTION	ISSUED DATE
FG441610I	Rev. 01	Initial issue of report	May 28, 2024



SUMMARY OF TEST RESULT

Report Section	FCC Rule	Description	Limit	Result	Remark
3.4	§2.1046	Conducted Output Power	Reporting Only	PASS	-
	§22.913(a)(5)	Effective Radiated Power (5G NR n5, n26)	ERP < 7 Watt		
	§27.50(c)(10)	Effective Radiated Power (5G NR n12)	ERP < 3 Watt		
	§24.232(c)	Equivalent Isotropic Radiated Power (5G NR n2, n25)	EIRP < 2Watt		
3.5	§24.232(d)	Peak-to-Average Ratio	<13 dB	PASS	-
3.6	§2.1049	Occupied Bandwidth	Reporting Only	PASS	-
3.7	§2.1051	Conducted Band Edge Measurement (5G NR n5, n26)	< 43+10log ₁₀ (P[Watts])	PASS	-
	§22.917(a)				
	§24.238(a)				
	§27.53(g)				
3.8	§2.1051	Conducted Spurious Emission (5G NR n5, n26)	< 43+10log ₁₀ (P[Watts])	PASS	-
	§22.917(a)				
	§24.238(a)				
	§27.53(g)				
3.9	§2.1055	Frequency Stability Temperature & Voltage	< 2.5 ppm for Part 22	PASS	-
	§22.355		Within Authorized Band		
	§24.235 §27.54				
4.4	§2.1053	Radiated Spurious Emission (5G NR n5, n26)	< 43+10log ₁₀ (P[Watts])	PASS	Under limit 27.17 dB at 10104.360 MHz
	§22.917(a)				
	§24.238(a)				
	§27.53(g)				

Conformity Assessment Condition:

- The test results (PASS/FAIL) with all measurement uncertainty excluded are presented against the regulation limits or in accordance with the requirements stipulated by the applicant/manufacturer who shall bear all the risks of non-compliance that may potentially occur if measurement uncertainty is taken into account.
- The measurement uncertainty please refer to each test result in the section "Measurement Uncertainty"

Disclaimer:

The product specifications of the EUT presented in the test report that may affect the test assessments are declared by the manufacturer who shall take full responsibility for the authenticity.



1 General Description

1.1 Applicant

Xiaomi Communications Co., Ltd.

#019, 9th Floor, Building 6, 33 Xi'erqi Middle Road, Haidian District, Beijing, China, 100085

1.2 Manufacturer

Xiaomi Communications Co., Ltd.

#019, 9th Floor, Building 6, 33 Xi'erqi Middle Road, Haidian District, Beijing, China, 100085

1.3 Product Feature of Equipment Under Test

Product Feature	
Equipment	Mobile Phone
Brand Name	Xiaomi
Model Name	2407FPN8EG
FCC ID	2AFZZPN8EG
IMEI Code	Conducted : 869018070053667/869018070053675 Radiation : 869018070053741/869018070053758
HW Version	13520N12
SW Version	Xiaomi HyperOS 1.0
EUT Stage	Identical Prototype

1.4 Product Specification of Equipment Under Test

Standards-related Product Specification	
Tx Frequency	5G NR n2 : 1850 MHz ~ 1910 MHz 5G NR n5 : 824 MHz ~ 849 MHz 5G NR n12 : 699 MHz ~ 716 MHz 5G NR n25 : 1850 MHz ~ 1915 MHz 5G NR n26 : 824 MHz ~ 849 MHz
Rx Frequency	5G NR n2 : 1930 MHz ~ 1990 MHz 5G NR n5 : 869 MHz ~ 894 MHz 5G NR n12 : 729 MHz ~ 746 MHz 5G NR n25 : 1930 MHz ~ 1995 MHz 5G NR n26 : 869 MHz ~ 894 MHz
Bandwidth	15kHz: n2, n5, n26: 5MHz / 10MHz / 15MHz / 20MHz n25: 5MHz / 10MHz / 15MHz / 20MHz / 25MHz / 30MHz / 40MHz n12: 5MHz / 10MHz / 15MHz 30kHz: n2, n5, n26: 10MHz / 15MHz / 20MHz n25: 10MHz / 15MHz / 20MHz / 25MHz / 30MHz / 40MHz n12: 10MHz / 15MHz
SCS	15kHz, 30 kHz



Antenna Gain	<p><Ant. 0>: n5: -4.1 dBi n12: -4.1 dBi n26: -4.1 dBi</p> <p><Ant. 1>: n5: -3.2 dBi n12: -3.8 dBi n26: -3.2 dBi</p> <p><Ant. 2>: n2: -3.71 dBi n25: -3.71 dBi</p> <p><Ant. 3>: n2: -1.6 dBi n25: -1.6 dBi</p> <p><Ant. 4>: n2: -4.2 dBi n25: -4.2 dBi</p> <p><Ant. 5>: n2: -2.1 dBi n25: -2.1 dBi</p>
Type of Modulation	<p>CP-OFDM: QPSK / 16QAM / 64QAM / 256QAM DFT-s-OFDM: PI/2 BPSK / QPSK / 16QAM / 64QAM / 256QAM</p>

Remark:

1. The maximum ERP/EIRP is calculated from max output power and max antenna gain, only the maximum ERP/EIRP are shown in the report: 5G NR n2/25 for Ant. 3, n5/n26 for Ant. 1, and /n12 for Ant. 0.
2. 5G NR n2/n12/n25/n26 only support SA mode, n5 support SA mode and NSA mode. According to the maximum power between SA and NSA mode, SA covers NSA mode.
3. 5G NR n2/n5/n12/n25/n26 support SCS 15kHz and 30kHz. According to the maximum power, full test 15kHz to cover 30kHz.
4. The device supports n2/25(1T4R) SRS resources on Ant.2/3/4/5, only the test data of worst Ant.2 is showed in the report according to the maximum conducted power.
5. All the supported ENDC combinations are verified conducted power, only the ENDC combination with highest power are shown in the report.
6. The EN-DC mode combination could be referred to the product spec.

1.5 Modification of EUT

No modifications are made to the EUT during all test items.



1.6 Maximum ERP/EIRP and Emission Designator

5G NR n2		PI/2 BPSK / QPSK		16QAM / 64QAM / 256QAM	
BW (MHz)	Frequency Range (MHz)	Maximum EIRP(W)	Emission Designator (99%OBW)	Maximum EIRP(W)	Emission Designator (99%OBW)
5	1852.5 ~ 1907.5	0.1592	4M47G7D	0.1282	4M47W7D
10	1855.0 ~ 1905.0	0.1570	9M28G7D	0.1271	9M30W7D
15	1857.5 ~ 1902.5	0.1578	14M1G7D	0.1288	14M1W7D
20	1860.0 ~ 1900.0	0.1622	18M9G7D	0.1318	18M9W7D

5G NR n25		PI/2 BPSK / QPSK		16QAM / 64QAM / 256QAM	
BW (MHz)	Frequency Range (MHz)	Maximum EIRP(W)	Emission Designator (99%OBW)	Maximum EIRP(W)	Emission Designator (99%OBW)
5	1852.5 ~ 1912.5	0.1671	4M47G7D	0.1374	4M47W7D
10	1855.0 ~ 1910.0	0.1667	9M28G7D	0.1400	9M30W7D
15	1857.5 ~ 1907.5	0.1690	14M1G7D	0.1384	14M1W7D
20	1860.0 ~ 1905.0	0.1667	18M9G7D	0.1390	18M9W7D
25	1862.5 ~ 1902.5	0.1578	23M7G7D	0.1245	23M8W7D
30	1865.0 ~ 1900.0	0.1549	28M5G7D	0.1233	28M6W7D
40	1870.0 ~ 1895.0	0.1698	38M5G7D	0.1306	38M6W7D

5G NR n5		PI/2 BPSK / QPSK		16QAM / 64QAM / 256QAM	
BW (MHz)	Frequency Range (MHz)	Maximum ERP(W)	Emission Designator (99%OBW)	Maximum ERP(W)	Emission Designator (99%OBW)
5	826.5 ~ 846.5	0.0887	4M47G7D	0.0703	4M48W7D
10	829.0 ~ 844.0	0.0889	9M28G7D	0.0692	9M29W7D
15	831.5 ~ 841.5	0.0891	14M1G7D	0.0703	14M1W7D
20	834.0 ~ 839.0	0.0899	18M9G7D	0.0714	19M0W7D

5G NR n26		PI/2 BPSK / QPSK		16QAM / 64QAM / 256QAM	
BW (MHz)	Frequency Range (MHz)	Maximum ERP(W)	Emission Designator (99%OBW)	Maximum ERP(W)	Emission Designator (99%OBW)
5	826.5 ~ 846.5	0.0798	4M46G7D	0.0637	4M47W7D
10	829.0 ~ 844.0	0.0800	9M25G7D	0.0644	9M28W7D
15	831.5 ~ 841.5	0.0800	14M1G7D	0.0622	14M1W7D
20	834.0 ~ 839.0	0.0811	18M9G7D	0.0710	18M9W7D



5G NR n12		PI/2 BPSK / QPSK		16QAM / 64QAM / 256QAM	
BW (MHz)	Frequency Range (MHz)	Maximum ERP(W)	Emission Designator (99%OBW)	Maximum ERP(W)	Emission Designator (99%OBW)
5	701.5 ~ 713.5	0.0740	4M48G7D	0.0628	4M48W7D
10	704.0~ 711.0	0.0736	9M27G7D	0.0643	9M29W7D
15	706.5 ~ 708.5	0.0741	14M1G7D	0.0649	14M2W7D

Note:

- 5G NR n25 overlaps the entire frequency range of 5G NR n2. Therefore, the test results provided in this report covers 5G NR n25 as well as 5G NR n2.
- All modulations have been tested, only the worst test results of PSK & QAM are shown in the report.

1.7 Testing Location

Sporton International Inc. (ShenZhen) is accredited to ISO/IEC 17025:2017 by American Association for Laboratory Accreditation with Certificate Number 5145.01.

Test Firm	Sporton International Inc. (ShenZhen)		
Test Site Location	1/F, 2/F, Bldg 5, Shiling Industrial Zone, Xinwei Village, Xili, Nanshan, Shenzhen, 518055 People's Republic of China TEL: +86-755-86379589 FAX: +86-755-86379595		
Test Site No.	Sporton Site No.	FCC Designation No.	FCC Test Firm Registration No.
	TH01-SZ	CN1256	421272

Test Firm	Sporton International Inc. (ShenZhen)		
Test Site Location	101, 1st Floor, Block B, Building 1, No. 2, Tengfeng 4th Road, Fenghuang Community, Fuyong Street, Baoan District, Shenzhen City, Guangdong Province 518103 People's Republic of China TEL: +86-755-86066985		
Test Site No.	Sporton Site No.	FCC Designation No.	FCC Test Firm Registration No.
	03CH04-SZ	CN1256	421272

1.8 Test Software

Item	Site	Manufacture	Name	Version
1.	03CH04-SZ	AUDIX	E3	6.2009-8-24



1.9 Applicable Standards

According to the specifications of the manufacturer, the EUT must comply with the requirements of the following standards:

- ♦ 47 CFR Part 2, 22, 24, 27
- ♦ ANSI C63.26-2015
- ♦ FCC KDB 971168 D01 Power Meas License Digital Systems v03r01
- ♦ FCC KDB 412172 D01 Determining ERP and EIRP v01r01

Remark:

All test items were verified and recorded according to the standards and without any deviation during the test.

2 Test Configuration of Equipment Under Test

2.1 Test Mode

Antenna port conducted and radiated test items are performed according to KDB 971168 D01 Power Meas License Digital Systems v03r01 with maximum output power.

For radiated measurement, pre-scanned in three orthogonal panels, X, Y, Z. The worst cases (Y plane) were recorded in this report.

The device is investigated from 30MHz to 10 times of fundamental signal for radiated spurious emission test under different RB size/offset and modulations in exploratory test. Subsequently, only the worst case emissions are reported.

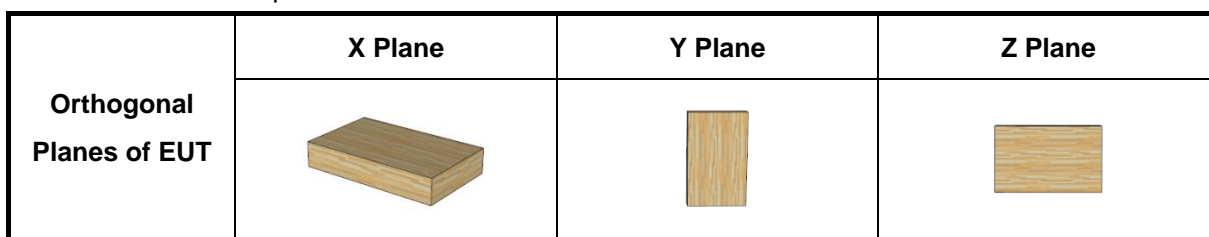

Test Items	5G NR	Bandwidth (MHz)														Modulation					RB #		Test Channel		
		5	10	15	20	25	30	35	40	50	60	70	80	90	100	PI/2 BPSK	QPSK	16 QAM	64 QAM	256 QAM	1	Full	L	M	H
Max. Output Power	n2	v	v	v	v	-	-	-	-	-	-	-	-	-	-	v	v	v	v	v	v	v	v	v	v
	n5	v	v	v	v	-	-	-	-	-	-	-	-	-	-	v	v	v	v	v	v	v	v	v	v
	n12	v	v	v	-	-	-	-	-	-	-	-	-	-	-	v	v	v	v	v	v	v	v	v	v
	n25	v	v	v	v	v	v	-	v	-	-	-	-	-	-	v	v	v	v	v	v	v	v	v	v
	n26	v	v	v	v	-	-	-	-	-	-	-	-	-	-	v	v	v	v	v	v	v	v	v	v
Peak-to-Average Ratio	n12		v		-	-	-	-	-	-	-	-	-	-	v	v						v		v	
	n25				v					-	-	-	-	-	v	v						v		v	
	n26				v	-	-	-	-	-	-	-	-	-	v	v						v		v	
	n5				v	-	-	-	-	-	-	-	-	-	v	v						v		v	
26dB and 99% Bandwidth	n12	v	v	v	-	-	-	-	-	-	-	-	-	-		v	v	v	v		v		v		
	n25	v	v	v	v	v	v	v	v	-	-	-	-	-		v	v	v	v		v		v		
	n26	v	v	v	v	-	-	-	-	-	-	-	-	-		v	v	v	v		v		v		
	n5	v	v	v	v	-	-	-	-	-	-	-	-	-		v	v	v	v		v		v		
Conducted Band Edge	n12	v	v	v	-	-	-	-	-	-	-	-	-	-	v	v					v	v	v	v	
	n25	v			v				v	-	-	-	-	-	v	v					v	v	v	v	
	n26	v	v		v	-	-	-	-	-	-	-	-	-	v	v					v	v	v	v	
	n5	v	v		v	-	-	-	-	-	-	-	-	-	v	v					v	v	v	v	
Conducted Spurious Emission	n12	v	v	v	-	-	-	-	-	-	-	-	-	-	v	v					v		v	v	
	n25	v			v				v	-	-	-	-	-	v	v					v		v	v	
	n26	v	v		v	-	-	-	-	-	-	-	-	-	v	v					v		v	v	
	n5	v	v		v	-	-	-	-	-	-	-	-	-	v	v					v		v	v	



Test Items	5G NR	Bandwidth (MHz)														Modulation					RB #		Test Channel		
		5	10	15	20	25	30	35	40	50	60	70	80	90	100	PI/2 BPSK	QPSK	16 QAM	64 QAM	256 QAM	1	Full	L	M	H
Frequency Stability	n12		v		-	-	-	-	-	-	-	-	-	-		v					v		v		
	n25				v			-		-	-	-	-	-		v					v		v		
	n26				v	-	-	-	-	-	-	-	-	-		v					v		v		
	n5				v	-	-	-	-	-	-	-	-	-		v					v		v	v	
E.R.P / E.I.R.P	n2	v	v	v	v	-	-	-	-	-	-	-	-	-	v	v	v	v	v	v	v	v	v	v	
	n5	v	v	v	v	-	-	-	-	-	-	-	-	-	v	v	v	v	v	v	v	v	v	v	
	n12	v	v	v	-	-	-	-	-	-	-	-	-	-	v	v	v	v	v	v	v	v	v	v	
	n25	v	v	v	v	v	v	-	v	-	-	-	-	-	v	v	v	v	v	v	v	v	v	v	
	n26	v	v	v	v	-	-	-	-	-	-	-	-	-	v	v	v	v	v	v	v	v	v	v	
Radiated Spurious Emission	n12	Worst Case																						v	
	n25	Worst Case																						v	
	n26	Worst Case																						v	
	n5	Worst Case																						v	
Note	1. The mark "v" means that this configuration is chosen for testing 2. The mark "-" means that this bandwidth is not supported. 3. The device is investigated from 30MHz to 10 times of fundamental signal for radiated spurious emission test under different RB size/offset and modulations in exploratory test. Subsequently, only the worst case emissions are reported. 4. Frequency Stability : Normal Voltage = 3.89V ; Low Voltage =3.50V ; High Voltage =4.30V																								

2.2 Connection Diagram of Test System

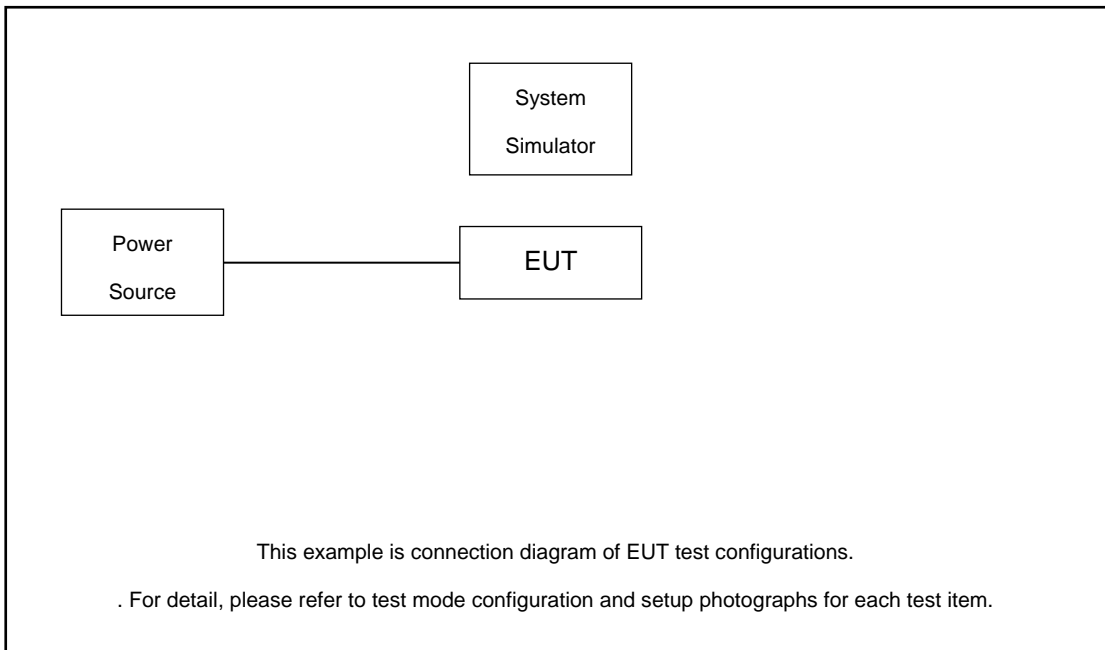

The EUT has been configuration operated in a manner tended to maximize its emission characteristics in a typical application.

2.3 Support Unit used in test configuration and system

Item	Equipment	Trade Name	Model No.	FCC ID	Data Cable	Power Cord
1.	DC Power Supply	GW	GPS-3030D	N/A	N/A	Unshielded, 1.8 m
2.	LTE Base Station	Anritsu	MT8821C	N/A	N/A	Unshielded, 1.8 m
3.	NR Base Station	Anritsu	MT8000A	N/A	N/A	Unshielded, 1.8 m

2.4 Measurement Results Explanation Example

For all conducted test items:

The offset level is set in the spectrum analyzer to compensate the RF cable loss between EUT conducted output port and spectrum analyzer. With the offset compensation, the spectrum analyzer reading level is exactly the EUT RF output level.

The spectrum analyzer offset is derived from RF cable loss.

Offset = RF cable loss.

Following shows an offset computation example with cable loss 7.5 dB.

Example : *Offset(dB) = RF cable loss(dB).*

= 7.5 (dB)



2.5 Frequency List of Low/Middle/High Channels

5G NR n2 Channel and Frequency List for SCS 15K & 30K				
BW [MHz]	Channel/Frequency(MHz)	Lowest	Middle	Highest
20	Channel	372000	376000	380000
	Frequency	1860	1880	1900
15	Channel	371500	376000	380500
	Frequency	1857.5	1880	1902.5
10	Channel	371000	376000	381000
	Frequency	1855	1880	1905
5	Channel	370500	376000	381500
	Frequency	1852.5	1880	1907.5

Note: SCS 30KHz does not support BW 5MHz.

5G NR n5 Channel and Frequency List for SCS 15K & 30K				
BW [MHz]	Channel/Frequency(MHz)	Lowest	Middle	Highest
20	Channel	166800	167300	167800
	Frequency	834	836.5	839
15	Channel	166300	167300	168300
	Frequency	831.5	836.5	841.5
10	Channel	165800	167300	168800
	Frequency	829	836.5	844
5	Channel	165300	167300	169300
	Frequency	826.5	836.5	846.5

Note: SCS 30KHz does not support BW 5MHz.

5G NR n12 Channel and Frequency List for SCS 15K & 30K				
BW [MHz]	Channel/Frequency(MHz)	Lowest	Middle	Highest
15	Channel	141300	141500	141700
	Frequency	706.5	707.5	708.5
10	Channel	140800	141500	142200
	Frequency	704	707.5	711
5	Channel	140300	141500	142700
	Frequency	701.5	707.5	713.5

Note: SCS 30KHz does not support BW 5MHz.



5G NR n25 Channel and Frequency List for SCS 15K & 30K				
BW [MHz]	Channel/Frequency(MHz)	Lowest	Middle	Highest
40	Channel	374000	376500	379000
	Frequency	1870	1882.5	1895
30	Channel	373000	376500	380000
	Frequency	1865	1882.5	1900
25	Channel	372500	376500	380500
	Frequency	1862.5	1882.5	1902.5
20	Channel	372000	376500	381000
	Frequency	1860	1882.5	1905
15	Channel	371500	376500	381500
	Frequency	1857.5	1882.5	1907.5
10	Channel	371000	376500	382000
	Frequency	1855	1882.5	1910
5	Channel	370500	376500	382500
	Frequency	1852.5	1882.5	1912.5

Note: SCS 30KHz does not support BW 5MHz.

5G NR n26 Channel and Frequency List for SCS 15K & 30K				
BW [MHz]	Channel/Frequency(MHz)	Lowest	Middle	Highest
20	Channel	166800	167300	167800
	Frequency	834	836.5	839
15	Channel	166300	167300	168300
	Frequency	831.5	836.5	841.5
10	Channel	165800	167300	168800
	Frequency	829	836.5	844
5	Channel	165300	167300	169300
	Frequency	826.5	836.5	846.5

Note: SCS 30KHz does not support BW 5MHz.

3 Conducted Test Items

3.1 Measuring Instruments

See list of measuring instruments of this test report.

3.2 Test Setup

3.2.1 Conducted Output Power



3.2.2 Peak-to-Average Ratio, Occupied Bandwidth ,Conducted Band-Edge and Conducted Spurious Emission

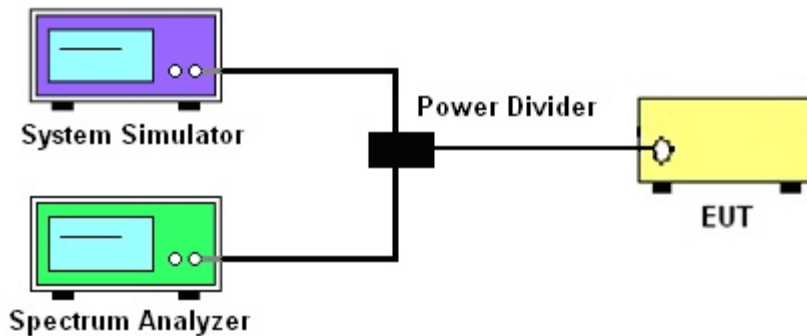

3.2.3 Frequency Stability

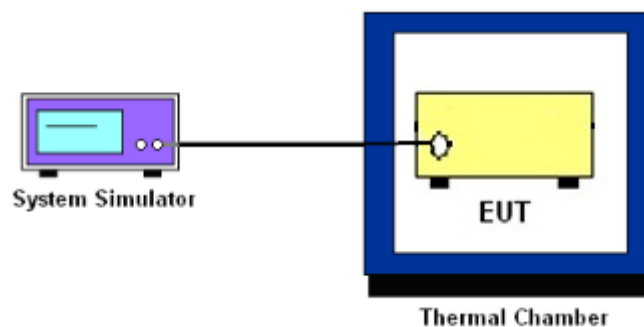

3.3 Test Result of Conducted Test

Please refer to Appendix A.



3.4 Conducted Output Power and ERP/EIRP

3.4.1 Description of the Conducted Output Power Measurement and ERP/EIRP Measurement

A system simulator was used to establish communication with the EUT. Its parameters were set to force the EUT transmitting at maximum output power. The measured power in the radio frequency on the transmitter output terminals shall be reported.

The ERP of mobile transmitters must not exceed 7 Watts for 5G NR n5, n26.

The ERP of mobile transmitters must not exceed 3 Watts for 5G NR n12.

The EIRP of mobile transmitters must not exceed 2 Watts for 5G NR n2, n25.

According to KDB 412172 D01 Power Approach,

$EIRP = P_T + G_T - L_C$, $ERP = EIRP - 2.15$, where

P_T = transmitter output power in dBm

G_T = gain of the transmitting antenna in dBi

L_C = signal attenuation in the connecting cable between the transmitter and antenna in dB

3.4.2 Test Procedures

1. The testing follows ANSI C63.26 Section 5.2
2. The transmitter output port was connected to the system simulator.
3. Set EUT at maximum power through the system simulator.
4. Select lowest, middle, and highest channels for each band and different modulation.
5. Measure and record the power level from the system simulator.



3.5 Peak-to-Average Ratio

3.5.1 Description of the PAR Measurement

Power Complementary Cumulative Distribution Function (CCDF) curves provide a means for characterizing the power peaks of a digitally modulated signal on a statistical basis. A CCDF curve depicts the probability of the peak signal amplitude exceeding the average power level. Most contemporary measurement instrumentation include the capability to produce CCDF curves for an input signal provided that the instrument's resolution bandwidth can be set wide enough to accommodate the entire input signal bandwidth. In measuring transmissions in this band using an average power technique, the peak-to-average ratio (PAR) of the transmission may not exceed 13 dB.

3.5.2 Test Procedures

1. The testing follows ANSI C63.26 Section 5.2.3.4 (CCDF).
2. The EUT was connected to spectrum and system simulator via a power divider.
3. Set the CCDF (Complementary Cumulative Distribution Function) option in spectrum analyzer.
4. The highest RF powers were measured and recorded the maximum PAPR level associated with a probability of 0.1 %.
5. Record the deviation as Peak to Average Ratio.



3.6 Occupied Bandwidth

3.6.1 Description of Occupied Bandwidth Measurement

The occupied bandwidth is the width of a frequency band such that, below the lower and above the upper frequency limits, the mean powers emitted are each equal to a specified percentage 0.5% of the total mean transmitted power.

The 26 dB emission bandwidth is defined as the frequency range between two points, one above and one below the carrier frequency, at which the spectral density of the emission is attenuated 26 dB below the maximum in-band spectral density of the modulated signal. Spectral density (power per unit bandwidth) is to be measured with a detector of resolution bandwidth equal to approximately 1.0% of the emission bandwidth.

3.6.2 Test Procedures

1. The testing follows ANSI C63.26 Section 5.4
2. The EUT was connected to spectrum analyzer and system simulator via a power divider.
3. The spectrum analyzer center frequency is set to the nominal EUT channel center frequency. The span range for the spectrum analyzer shall be between two and five times the anticipated OBW.
4. The nominal resolution bandwidth (RBW) shall be in the range of 1 to 5 % of the anticipated OBW, and the VBW shall be at least 3 times the RBW.
5. Set the detection mode to peak, and the trace mode to max hold.
6. Determine the reference value: Set the EUT to transmit a modulated signal. Allow the trace to stabilize. Set the spectrum analyzer marker to the highest level of the displayed trace. (this is the reference value)
7. Determine the “-26 dB down amplitude” as equal to (Reference Value – X).
8. Place two markers, one at the lowest and the other at the highest frequency of the envelope of the spectral display such that each marker is at or slightly below the “-X dB down amplitude” determined in step 6. If a marker is below this “-X dB down amplitude” value it shall be placed as close as possible to this value. The OBW is the positive frequency difference between the two markers.
9. Use the 99 % power bandwidth function of the spectrum analyzer and report the measured bandwidth.



3.7 Conducted Band Edge

3.7.1 Description of Conducted Band Edge Measurement

22.917(a)

For operations in the 824 – 849 MHz band, the FCC limit is $43 + 10\log_{10}(P[\text{Watts}])$ dB below the transmitter power $P(\text{Watts})$ in a 100kHz bandwidth. However, in the 1MHz bands immediately outside and adjacent to the licensee's frequency block, a resolution bandwidth of at least one percent of the emission bandwidth of the fundamental emission of the transmitter may be employed.

24.238 (a)

For operations in the 1850-1910 and 1930-1990 MHz band, the FCC limit is $43 + 10\log_{10}(P[\text{Watts}])$ dB below the transmitter power $P(\text{Watts})$ in a 1MHz bandwidth. However, in the 1 MHz bands immediately outside and adjacent to the frequency block a resolution bandwidth of at least one percent of the emission bandwidth of the fundamental emission of the transmitter may be employed.

27.53 (g)

For operations in the 600MHz band and 698 -746 MHz band, the FCC limit is $43 + 10\log_{10}(P[\text{Watts}])$ dB below the transmitter power $P(\text{Watts})$ in a 100 kHz bandwidth. However, in the 100 kilohertz bands immediately outside and adjacent to a licensee's frequency block, a resolution bandwidth of at least 30 kHz may be employed.



3.7.2 Test Procedures

1. The testing follows ANSI C63.26 section 5.7
2. The EUT was connected to spectrum analyzer and system simulator via a power divider.
3. The band edges of low and high channels for the highest RF powers were measured.
4. Set RBW \geq 1% EBW in the 1MHz band immediately outside and adjacent to the band edge.
5. Beyond the 1 MHz band from the band edge, RBW=1MHz was used or a narrower RBW was used (generally limited to no less than 1% of the OBW) and the measured power was integrated over the full required measurement bandwidth.
6. Set spectrum analyzer with RMS detector.
7. The RF fundamental frequency should be excluded against the limit line in the operating frequency band.
8. Checked that all the results comply with the emission limit line.

Example:

The limit line is derived from $43 + 10\log(P)$ dB below the transmitter power P(Watts)

$$= P(W) - [43 + 10\log(P)] \text{ (dB)}$$

$$= [30 + 10\log(P)] \text{ (dBm)} - [43 + 10\log(P)] \text{ (dB)} = -13\text{dBm.}$$

9. When using the integration method, the starting frequency of the integration shall be centered at one-half of the RBW away from the band edge.



3.8 Conducted Spurious Emission

3.8.1 Description of Conducted Spurious Emission Measurement

The power of any emission outside of the authorized operating frequency ranges must be lower than the transmitter power (P) by a factor of at least $43 + 10 \log (P)$ dB.

It is measured by means of a calibrated spectrum analyzer and scanned from 30 MHz up to a frequency including its 10th harmonic.

3.8.2 Test Procedures

1. The testing follows ANSI C63.26 section 5.7
2. The EUT was connected to spectrum analyzer and system simulator via a power divider.
3. The RF output of EUT was connected to the spectrum analyzer by RF cable and attenuator. The path loss was compensated to the results for each measurement.
4. The middle channel for the highest RF power within the transmitting frequency was measured.
5. The conducted spurious emission for the whole frequency range was taken.
6. Make the measurement with the spectrum analyzer's RBW = 1MHz, VBW = 3MHz.
7. Set spectrum analyzer with RMS detector.
8. Taking the record of maximum spurious emission.
9. The RF fundamental frequency should be excluded against the limit line in the operating frequency band.
10. The limit line is derived from $43 + 10\log(P)$ dB below the transmitter power P(Watts)
= $P(W) - [43 + 10\log(P)]$ (dB)
= $[30 + 10\log(P)]$ (dBm) - $[43 + 10\log(P)]$ (dB)
= -13dBm.

3.9 Frequency Stability

3.9.1 Description of Frequency Stability Measurement

The frequency stability shall be measured by variation of ambient temperature and variation of primary supply voltage to ensure that the fundamental emission stays within the authorized frequency block. The frequency stability of the transmitter shall be maintained within $\pm 0.00025\%$ ($\pm 2.5\text{ppm}$) of the center frequency.

3.9.2 Test Procedures for Temperature Variation

1. The testing follows ANSI C63.26 section 5.6.4
2. The EUT was set up in the thermal chamber and connected with the system simulator.
3. With power OFF, the temperature was decreased to -30°C and the EUT was stabilized before testing. Power was applied and the maximum change in frequency was recorded within one minute.
4. With power OFF, the temperature was raised in 10°C step up to 50°C . The EUT was stabilized at each step for at least half an hour. Power was applied and the maximum frequency change was recorded within one minute.

3.9.3 Test Procedures for Voltage Variation

1. The testing follows ANSI C63.26 section 5.6.5
2. The EUT was placed in a temperature chamber at $20\pm 5^{\circ}\text{C}$ and connected with the system simulator.
3. The power supply voltage to the EUT was varied from 85% to 115% of the nominal value for other than hand carried battery equipment.
4. For hand carried, battery powered equipment, reduce the primary ac or dc supply voltage to the battery operating end point, which shall be specified by the manufacturer.
5. The variation in frequency was measured for the worst case.

4 Radiated Test Items

4.1 Measuring Instruments

See list of measuring instruments of this test report.

4.2 Test Setup

4.2.1 For radiated test below 30MHz

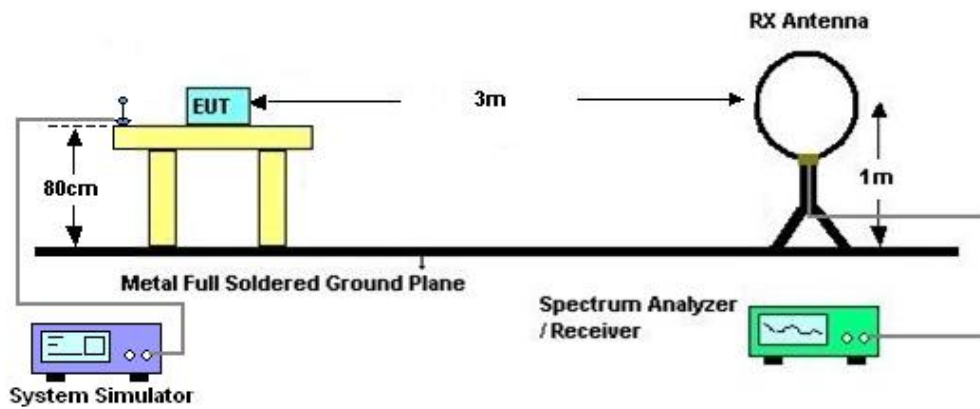

4.2.2 For radiated test from 30MHz to 1GHz

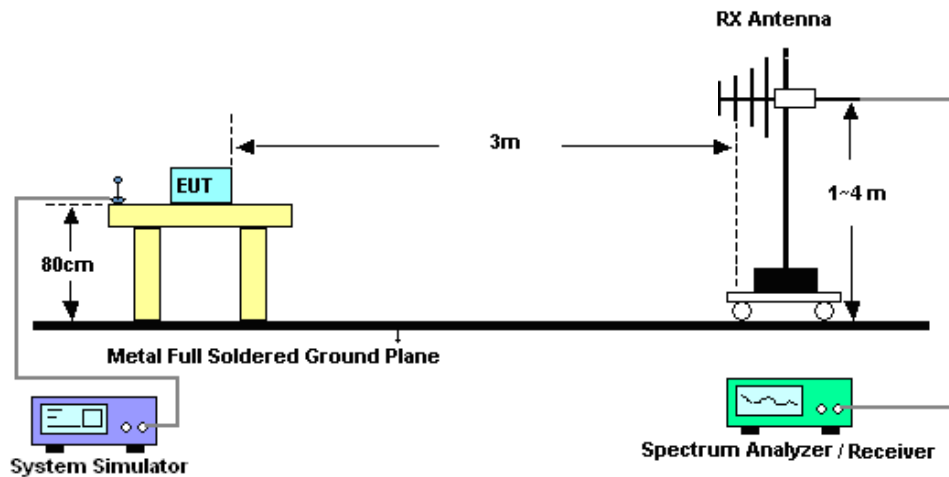

4.2.3 For radiated test above 1GHz

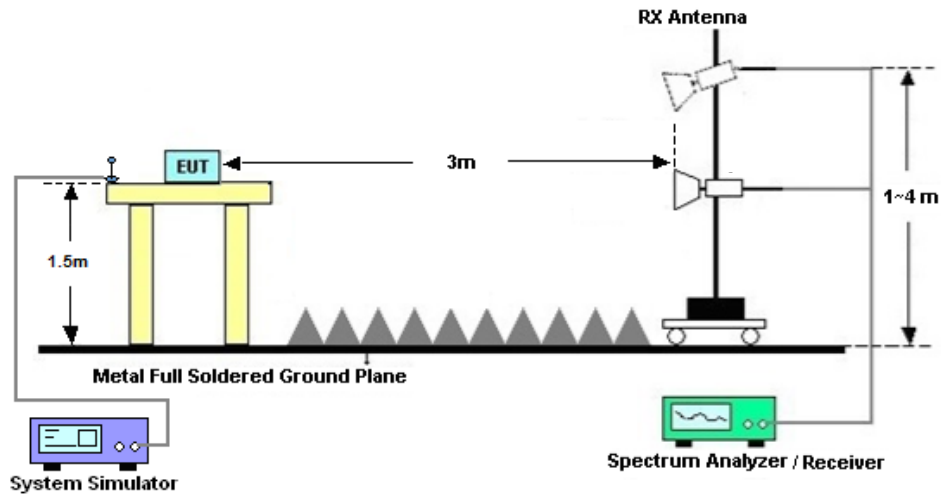

4.3 Test Result of Radiated Test

The low frequency, which started from 9 kHz to 30MHz, was pre-scanned and the result which was 20dB lower than the limit line was not reported.

Please refer to Appendix B.



4.4 Radiated Spurious Emission

4.4.1 Description of Radiated Spurious Emission

The radiated spurious emission was measured by substitution method according to ANSI C63.26. The power of any emission outside of the authorized operating frequency ranges must be attenuated below the transmitter power (P) by a factor of at least $43 + 10 \log(P)$ dB.

The spectrum is scanned from 30 MHz up to a frequency including its 10th harmonic.

4.4.2 Test Procedures

1. The testing follows ANSI C63.26 Section 5.5
2. The EUT was placed on a turntable with 0.8 meter height for frequency below 1GHz and 1.5 meter height for frequency above 1GHz respectively above ground.
3. The EUT was set 3 meters from the receiving antenna mounted on the antenna tower.
4. The table was rotated 360 degrees to determine the position of the highest spurious emission.
5. The height of the receiving antenna is varied between 1m to 4m to search the maximum spurious emission for both horizontal and vertical polarizations.
6. During the measurement, the system simulator parameters were set to force the EUT transmitting at maximum output power.
7. Make the measurement with the spectrum analyzer's RBW = 1MHz, VBW = 3MHz, taking the record of maximum spurious emission.
8. A horn antenna was substituted in place of the EUT and was driven by a signal generator.
9. Tune the output power of signal generator to the same emission level with EUT maximum spurious emission.
10. $EIRP \text{ (dBm)} = S.G. \text{ Power} - Tx \text{ Cable Loss} + Tx \text{ Antenna Gain}$
11. $ERP \text{ (dBm)} = EIRP - 2.15$
12. The RF fundamental frequency should be excluded against the limit line in the operating frequency band.

The limit line is derived from $43 + 10\log(P)$ dB below the transmitter power P(Watts)
 $= P(W) - [43 + 10\log(P)] \text{ (dB)}$
 $= [30 + 10\log(P)] \text{ (dBm)} - [43 + 10\log(P)] \text{ (dB)}$
 $= -13\text{dBm}.$



5 List of Measuring Equipment

Instrument	Manufacturer	Model No.	Serial No.	Characteristics	Calibration Date	Test Date	Due Date	Remark
Spectrum Analyzer	R&S	FSV40	101078	10Hz~40GHz	Apr. 09, 2024	Apr. 24, 2024~ May 15, 2024	Apr. 08, 2025	Conducted (TH01-SZ)
DC Power Supply	TTI	PL330P	290070	Max 32V , 3A	Oct. 16, 2023	Apr. 24, 2024~ May 15, 2024	Oct. 15, 2024	Conducted (TH01-SZ)
Power Divider	TOJOIN	PS-2SM-04 265	60.06.020.007 7	0.4GHz~26.5GHz	Dec. 25, 2023	Apr. 24, 2024~ May 15, 2024	Dec. 24, 2024	Conducted (TH01-SZ)
Thermal Chamber	Ten Billion Hongzhangroup	LP-150U	H2014081803	-40~+150°C	Jul. 05, 2023	Apr. 24, 2024~ May 15, 2024	Jul. 04, 2024	Conducted (TH01-SZ)
EMI Test Receiver	R&S	ESR7	101404	9kHz~7GHz	Oct. 18, 2023	May 11, 2024	Oct. 17, 2024	Radiation (03CH04-SZ)
EXA Spectrum Analyzer	KEYSIGHT	N9010A	MY55150213	10Hz~44GHz	Jul. 07, 2023	May 11, 2024	Jul. 06, 2024	Radiation (03CH04-SZ)
Loop Antenna	R&S	HFH2-Z2	100354	9kHz~30MHz	Jun. 28, 2022	May 11, 2024	Jun. 27, 2024	Radiation (03CH04-SZ)
Bilog Antenna	TeseQ	CBL6111D	41909	30MHz~1GHz	May 09, 2024	May 11, 2024	May 08, 2025	Radiation (03CH04-SZ)
Double Ridge Horn Antenna	SCHWARZBECK	BBHA9120D	9120D-1474	1GHz~18GHz	Jul. 07, 2023	May 11, 2024	Jul. 06, 2024	Radiation (03CH04-SZ)
Horn Antenna	SCHWARZBECK	BBHA9170	9170#679	15GHz~40GHz	Jul. 08, 2023	May 11, 2024	Jul. 07, 2024	Radiation (03CH04-SZ)
Amplifier	Burgeon	BPA-530	102211	0.01Hz ~3000MHz	Oct. 18, 2023	May 11, 2024	Oct. 17, 2024	Radiation (03CH04-SZ)
HF Amplifier	MITEQ	AMF-7D-00 101800-30-1 0P-R	1943528	1GHz~18GHz	Oct. 18, 2023	May 11, 2024	Oct. 17, 2024	Radiation (03CH04-SZ)
HF Amplifier	MITEQ	TTA1840-35 -HG	1871923	18GHz~40GHz	Jul. 07, 2023	May 11, 2024	Jul. 06, 2024	Radiation (03CH04-SZ)
Amplifier	Agilent Technologies	83017A	MY57280136	500MHz~26.5GHz	Aug. 21, 2023	May 11, 2024	Aug. 20, 2024	Radiation (03CH04-SZ)
AC Power Source	APC	AFV-S-600B	F119050019	N/A	Oct. 18, 2023	May 11, 2024	Oct. 17, 2024	Radiation (03CH04-SZ)
Turn Table	EM	EM1000	N/A	0~360 degree	NCR	May 11, 2024	NCR	Radiation (03CH04-SZ)
Antenna Mast	EM	EM1000	N/A	1 m~4 m	NCR	May 11, 2024	NCR	Radiation (03CH04-SZ)

NCR: No Calibration Required



6 Measurement Uncertainty

The measurement uncertainties shown below were calculated in accordance with the requirements of ANSI 63.26-2015. All the measurement uncertainty value were shown with a coverage K=2 to indicate 95% level of confidence. The measurement data show herein meets or exceeds the CISPR measurement uncertainty values specified in CISPR 16-4-2 and can be compared directly to specified limit to determine compliance.

Uncertainty of Conducted Measurement

Test Item	Uncertainty
Conducted Spurious Emission & Bandedge	±1.34 dB
Occupied Channel Bandwidth	±0.012 MHz
Conducted Power	±1.34 dB
Peak to Average Ratio	±1.34 dB
Frequency Stability	±1.3 Hz

Uncertainty of Radiated Emission Measurement (30 MHz ~ 1 GHz)

Measuring Uncertainty for a Level of Confidence of 95% (U = 2Uc(y))	2.8 dB
---	--------

Uncertainty of Radiated Emission Measurement (1 GHz ~ 18 GHz)

Measuring Uncertainty for a Level of Confidence of 95% (U = 2Uc(y))	3.1 dB
---	--------

Uncertainty of Radiated Emission Measurement (18 GHz ~ 40 GHz)

Measuring Uncertainty for a Level of Confidence of 95% (U = 2Uc(y))	3.9 dB
---	--------

----- THE END -----



Appendix A. Test Results of Conducted Test

Test Engineer :	Khan Zheng	Temperature :	24~26°C
		Relative Humidity :	50~53%

FR1 N2 (ANT3) - SCS 15k

Transmitter Conducted Output Power And EIRP, (G_T - L_C)=-1.6dB

NR Band	SCS (kHz)	Bandwidth (MHz)	Arfcn	Freq (MHz)	Modulation	RB	Conducted Power(dBm)	EIRP (dBm)	EIRP (W)
2	15	5	370500	1852.5	DFT-s-OFDM QPSK	1@1	23.4	21.8	0.1514
2	15	5	370500	1852.5	DFT-s-OFDM 16 QAM	1@1	22.6	21	0.1259
2	15	5	376000	1880	DFT-s-OFDM QPSK	1@1	23.62	22.02	0.1592
2	15	5	376000	1880	DFT-s-OFDM 16 QAM	1@1	22.68	21.08	0.1282
2	15	5	381500	1907.5	DFT-s-OFDM QPSK	1@1	23.47	21.87	0.1538
2	15	5	381500	1907.5	DFT-s-OFDM 16 QAM	1@1	22.68	21.08	0.1282
2	15	10	371000	1855	DFT-s-OFDM QPSK	1@1	23.5	21.9	0.1549
2	15	10	371000	1855	DFT-s-OFDM 16 QAM	1@1	22.64	21.04	0.1271
2	15	10	376000	1880	DFT-s-OFDM QPSK	1@1	23.56	21.96	0.1570
2	15	10	376000	1880	DFT-s-OFDM 16 QAM	1@1	22.5	20.9	0.1230
2	15	10	381000	1905	DFT-s-OFDM QPSK	1@1	23.53	21.93	0.1560
2	15	10	381000	1905	DFT-s-OFDM 16 QAM	1@1	22.59	20.99	0.1256
2	15	15	371500	1857.5	DFT-s-OFDM QPSK	1@1	23.47	21.87	0.1538
2	15	15	371500	1857.5	DFT-s-OFDM 16 QAM	1@1	22.7	21.1	0.1288
2	15	15	376000	1880	DFT-s-OFDM QPSK	1@1	23.57	21.97	0.1574
2	15	15	376000	1880	DFT-s-OFDM 16 QAM	1@1	22.6	21	0.1259
2	15	15	380500	1902.5	DFT-s-OFDM QPSK	1@1	23.58	21.98	0.1578
2	15	15	380500	1902.5	DFT-s-OFDM 16 QAM	1@1	22.63	21.03	0.1268
2	15	20	372000	1860	DFT-s-OFDM PI/2 BPSK	50@25	23.33	21.73	0.1489
2	15	20	372000	1860	DFT-s-OFDM PI/2 BPSK	1@1	23.21	21.61	0.1449
2	15	20	372000	1860	DFT-s-OFDM PI/2 BPSK	1@104	23.27	21.67	0.1469
2	15	20	372000	1860	DFT-s-OFDM QPSK	50@25	23.28	21.68	0.1472
2	15	20	372000	1860	DFT-s-OFDM QPSK	1@1	23.49	21.89	0.1545
2	15	20	372000	1860	DFT-s-OFDM QPSK	1@104	23.59	21.99	0.1581
2	15	20	372000	1860	DFT-s-OFDM 16 QAM	50@25	22.66	21.06	0.1276
2	15	20	372000	1860	DFT-s-OFDM 16 QAM	1@1	22.7	21.1	0.1288
2	15	20	372000	1860	DFT-s-OFDM 16 QAM	1@104	22.66	21.06	0.1276
2	15	20	372000	1860	DFT-s-OFDM 64 QAM	50@25	21.17	19.57	0.0906
2	15	20	372000	1860	DFT-s-OFDM 64 QAM	1@1	20.96	19.36	0.0863
2	15	20	372000	1860	DFT-s-OFDM 64 QAM	1@104	21.12	19.52	0.0895
2	15	20	372000	1860	DFT-s-OFDM 256 QAM	50@25	19.18	17.58	0.0573
2	15	20	372000	1860	DFT-s-OFDM 256 QAM	1@1	19.38	17.78	0.0600
2	15	20	372000	1860	DFT-s-OFDM 256 QAM	1@104	19.49	17.89	0.0615
2	15	20	372000	1860	CP-OFDM QPSK	53@26	22.12	20.52	0.1127
2	15	20	372000	1860	CP-OFDM QPSK	1@1	22.77	21.17	0.1309
2	15	20	372000	1860	CP-OFDM QPSK	1@104	22.83	21.23	0.1327
2	15	20	376000	1880	DFT-s-OFDM PI/2 BPSK	50@25	23.26	21.66	0.1466

2	15	20	376000	1880	DFT-s-OFDM PI/2 BPSK	1@1	23.11	21.51	0.1416
2	15	20	376000	1880	DFT-s-OFDM PI/2 BPSK	1@104	23.24	21.64	0.1459
2	15	20	376000	1880	DFT-s-OFDM QPSK	50@25	23.41	21.81	0.1517
2	15	20	376000	1880	DFT-s-OFDM QPSK	1@1	23.57	21.97	0.1574
2	15	20	376000	1880	DFT-s-OFDM QPSK	1@104	23.61	22.01	0.1589
2	15	20	376000	1880	DFT-s-OFDM 16 QAM	50@25	22.68	21.08	0.1282
2	15	20	376000	1880	DFT-s-OFDM 16 QAM	1@1	22.55	20.95	0.1245
2	15	20	376000	1880	DFT-s-OFDM 16 QAM	1@104	22.76	21.16	0.1306
2	15	20	376000	1880	DFT-s-OFDM 64 QAM	50@25	21.21	19.61	0.0914
2	15	20	376000	1880	DFT-s-OFDM 64 QAM	1@1	21	19.4	0.0871
2	15	20	376000	1880	DFT-s-OFDM 64 QAM	1@104	21.07	19.47	0.0885
2	15	20	376000	1880	DFT-s-OFDM 256 QAM	50@25	19.26	17.66	0.0583
2	15	20	376000	1880	DFT-s-OFDM 256 QAM	1@1	19.39	17.79	0.0601
2	15	20	376000	1880	DFT-s-OFDM 256 QAM	1@104	19.49	17.89	0.0615
2	15	20	376000	1880	CP-OFDM QPSK	53@26	22.22	20.62	0.1153
2	15	20	376000	1880	CP-OFDM QPSK	1@1	22.84	21.24	0.1330
2	15	20	376000	1880	CP-OFDM QPSK	1@104	22.96	21.36	0.1368
2	15	20	380000	1900	DFT-s-OFDM PI/2 BPSK	50@25	23.3	21.7	0.1479
2	15	20	380000	1900	DFT-s-OFDM PI/2 BPSK	1@1	23.29	21.69	0.1476
2	15	20	380000	1900	DFT-s-OFDM PI/2 BPSK	1@104	23.34	21.74	0.1493
2	15	20	380000	1900	DFT-s-OFDM QPSK	50@25	23.47	21.87	0.1538
2	15	20	380000	1900	DFT-s-OFDM QPSK	1@1	23.59	21.99	0.1581
2	15	20	380000	1900	DFT-s-OFDM QPSK	1@104	23.7	22.1	0.1622
2	15	20	380000	1900	DFT-s-OFDM 16 QAM	50@25	22.8	21.2	0.1318
2	15	20	380000	1900	DFT-s-OFDM 16 QAM	1@1	22.68	21.08	0.1282
2	15	20	380000	1900	DFT-s-OFDM 16 QAM	1@104	22.72	21.12	0.1294
2	15	20	380000	1900	DFT-s-OFDM 64 QAM	50@25	21.22	19.62	0.0916
2	15	20	380000	1900	DFT-s-OFDM 64 QAM	1@1	21.1	19.5	0.0891
2	15	20	380000	1900	DFT-s-OFDM 64 QAM	1@104	21.09	19.49	0.0889
2	15	20	380000	1900	DFT-s-OFDM 256 QAM	50@25	19.31	17.71	0.0590
2	15	20	380000	1900	DFT-s-OFDM 256 QAM	1@1	19.47	17.87	0.0612
2	15	20	380000	1900	DFT-s-OFDM 256 QAM	1@104	19.55	17.95	0.0624
2	15	20	380000	1900	CP-OFDM QPSK	53@26	22.15	20.55	0.1135
2	15	20	380000	1900	CP-OFDM QPSK	1@1	22.81	21.21	0.1321
2	15	20	380000	1900	CP-OFDM QPSK	1@104	22.79	21.19	0.1315

FR1 N2 (ANT2) - SCS 30k

Transmitter Conducted Output Power And EIRP, ($G_T - L_C$)=-3.71dB

NR Band	SCS	BandWidth	Arfcn	Freq(MHz)	Modulation	RB	Conducted Power(dBm)	EIRP(dBm)	EIRP(W)
2	30	10	371000	1855	DFT-s-OFDM QPSK	1@1	24.66	20.95	0.1245
2	30	10	371000	1855	DFT-s-OFDM 16 QAM	1@1	23.47	19.76	0.0946
2	30	10	376000	1880	DFT-s-OFDM QPSK	1@1	24.4	20.69	0.1172
2	30	10	376000	1880	DFT-s-OFDM 16 QAM	1@1	23.48	19.77	0.0948
2	30	10	381000	1905	DFT-s-OFDM QPSK	1@1	24.41	20.7	0.1175
2	30	10	381000	1905	DFT-s-OFDM 16 QAM	1@1	23.56	19.85	0.0966
2	30	15	371500	1857.5	DFT-s-OFDM QPSK	1@1	24.33	20.62	0.1153
2	30	15	371500	1857.5	DFT-s-OFDM 16 QAM	1@1	23.47	19.76	0.0946
2	30	15	376000	1880	DFT-s-OFDM QPSK	1@1	24.36	20.65	0.1161
2	30	15	376000	1880	DFT-s-OFDM 16 QAM	1@1	23.41	19.7	0.0933
2	30	15	380500	1902.5	DFT-s-OFDM QPSK	1@1	24.65	20.94	0.1242
2	30	15	380500	1902.5	DFT-s-OFDM 16 QAM	1@1	23.45	19.74	0.0942
2	30	20	372000	1860	DFT-s-OFDM PI/2 BPSK	25@12	24.32	20.61	0.1151
2	30	20	372000	1860	DFT-s-OFDM PI/2 BPSK	1@1	24.28	20.57	0.1140
2	30	20	372000	1860	DFT-s-OFDM PI/2 BPSK	1@49	24.31	20.6	0.1148
2	30	20	372000	1860	DFT-s-OFDM QPSK	25@12	24.42	20.71	0.1178
2	30	20	372000	1860	DFT-s-OFDM QPSK	1@1	24.36	20.65	0.1161
2	30	20	372000	1860	DFT-s-OFDM QPSK	1@49	24.43	20.72	0.1180
2	30	20	372000	1860	DFT-s-OFDM 16 QAM	25@12	23.63	19.92	0.0982
2	30	20	372000	1860	DFT-s-OFDM 16 QAM	1@1	23.35	19.64	0.0920
2	30	20	372000	1860	DFT-s-OFDM 16 QAM	1@49	23.43	19.72	0.0938
2	30	20	372000	1860	DFT-s-OFDM 64 QAM	25@12	22.22	18.51	0.0710
2	30	20	372000	1860	DFT-s-OFDM 64 QAM	1@1	21.98	18.27	0.0671
2	30	20	372000	1860	DFT-s-OFDM 64 QAM	1@49	22.07	18.36	0.0685
2	30	20	372000	1860	DFT-s-OFDM 256 QAM	25@12	20.17	16.46	0.0443
2	30	20	372000	1860	DFT-s-OFDM 256 QAM	1@1	20.28	16.57	0.0454
2	30	20	372000	1860	DFT-s-OFDM 256 QAM	1@49	20.32	16.61	0.0458
2	30	20	372000	1860	CP-OFDM QPSK	25@12	23.16	19.45	0.0881
2	30	20	372000	1860	CP-OFDM QPSK	1@1	22.81	19.1	0.0813
2	30	20	372000	1860	CP-OFDM QPSK	1@49	22.88	19.17	0.0826
2	30	20	376000	1880	DFT-s-OFDM PI/2 BPSK	25@12	24.36	20.65	0.1161
2	30	20	376000	1880	DFT-s-OFDM PI/2 BPSK	1@1	24.23	20.52	0.1127
2	30	20	376000	1880	DFT-s-OFDM PI/2 BPSK	1@49	24.31	20.6	0.1148
2	30	20	376000	1880	DFT-s-OFDM QPSK	25@12	24.43	20.72	0.1180
2	30	20	376000	1880	DFT-s-OFDM QPSK	1@1	24.72	21.01	0.1262
2	30	20	376000	1880	DFT-s-OFDM QPSK	1@49	24.73	21.02	0.1265
2	30	20	376000	1880	DFT-s-OFDM 16 QAM	25@12	23.68	19.97	0.0993

2	30	20	376000	1880	DFT-s-OFDM 16 QAM	1@1	23.29	19.58	0.0908
2	30	20	376000	1880	DFT-s-OFDM 16 QAM	1@49	23.51	19.8	0.0955
2	30	20	376000	1880	DFT-s-OFDM 64 QAM	25@12	22.17	18.46	0.0701
2	30	20	376000	1880	DFT-s-OFDM 64 QAM	1@1	21.87	18.16	0.0655
2	30	20	376000	1880	DFT-s-OFDM 64 QAM	1@49	22.03	18.32	0.0679
2	30	20	376000	1880	DFT-s-OFDM 256 QAM	25@12	20.2	16.49	0.0446
2	30	20	376000	1880	DFT-s-OFDM 256 QAM	1@1	20.25	16.54	0.0451
2	30	20	376000	1880	DFT-s-OFDM 256 QAM	1@49	20.41	16.7	0.0468
2	30	20	376000	1880	CP-OFDM QPSK	25@12	23.17	19.46	0.0883
2	30	20	376000	1880	CP-OFDM QPSK	1@1	22.82	19.11	0.0815
2	30	20	376000	1880	CP-OFDM QPSK	1@49	22.92	19.21	0.0834
2	30	20	380000	1900	DFT-s-OFDM PI/2 BPSK	25@12	24.4	20.69	0.1172
2	30	20	380000	1900	DFT-s-OFDM PI/2 BPSK	1@1	24.31	20.6	0.1148
2	30	20	380000	1900	DFT-s-OFDM PI/2 BPSK	1@49	24.41	20.7	0.1175
2	30	20	380000	1900	DFT-s-OFDM QPSK	25@12	24.47	20.76	0.1191
2	30	20	380000	1900	DFT-s-OFDM QPSK	1@1	24.42	20.71	0.1178
2	30	20	380000	1900	DFT-s-OFDM QPSK	1@49	24.53	20.82	0.1208
2	30	20	380000	1900	DFT-s-OFDM 16 QAM	25@12	23.69	19.98	0.0995
2	30	20	380000	1900	DFT-s-OFDM 16 QAM	1@1	23.38	19.67	0.0927
2	30	20	380000	1900	DFT-s-OFDM 16 QAM	1@49	23.4	19.69	0.0931
2	30	20	380000	1900	DFT-s-OFDM 64 QAM	25@12	22.14	18.43	0.0697
2	30	20	380000	1900	DFT-s-OFDM 64 QAM	1@1	21.93	18.22	0.0664
2	30	20	380000	1900	DFT-s-OFDM 64 QAM	1@49	22.1	18.39	0.0690
2	30	20	380000	1900	DFT-s-OFDM 256 QAM	25@12	20.22	16.51	0.0448
2	30	20	380000	1900	DFT-s-OFDM 256 QAM	1@1	20.28	16.57	0.0454
2	30	20	380000	1900	DFT-s-OFDM 256 QAM	1@49	20.32	16.61	0.0458
2	30	20	380000	1900	CP-OFDM QPSK	25@12	23.09	19.38	0.0867
2	30	20	380000	1900	CP-OFDM QPSK	1@1	22.64	18.93	0.0782
2	30	20	380000	1900	CP-OFDM QPSK	1@49	22.78	19.07	0.0807

FR1 N5 (ANT1) - SCS 15k

Transmitter Conducted Output Power And ERP, (G_T - L_C)=-3.2dB

NR Band	SCS (kHz)	Bandwidth (MHz)	Arfcn	Freq (MHz)	Modulation	RB	Conducted Power(dBm)	ERP (dBm)	ERP (W)
5	15	5	165300	826.5	DFT-s-OFDM QPSK	1@1	24.83	19.48	0.0887
5	15	5	165300	826.5	DFT-s-OFDM 16 QAM	1@1	23.82	18.47	0.0703
5	15	5	167300	836.5	DFT-s-OFDM QPSK	1@1	24.58	19.23	0.0838
5	15	5	167300	836.5	DFT-s-OFDM 16 QAM	1@1	23.58	18.23	0.0665
5	15	5	169300	846.5	DFT-s-OFDM QPSK	1@1	24.43	19.08	0.0809
5	15	5	169300	846.5	DFT-s-OFDM 16 QAM	1@1	23.41	18.06	0.0640
5	15	10	165800	829	DFT-s-OFDM QPSK	1@1	24.84	19.49	0.0889
5	15	10	165800	829	DFT-s-OFDM 16 QAM	1@1	23.75	18.4	0.0692
5	15	10	167300	836.5	DFT-s-OFDM QPSK	1@1	24.57	19.22	0.0836
5	15	10	167300	836.5	DFT-s-OFDM 16 QAM	1@1	23.71	18.36	0.0685
5	15	10	168800	844	DFT-s-OFDM QPSK	1@1	24.44	19.09	0.0811
5	15	10	168800	844	DFT-s-OFDM 16 QAM	1@1	23.49	18.14	0.0652
5	15	15	166300	831.5	DFT-s-OFDM QPSK	1@1	24.85	19.5	0.0891
5	15	15	166300	831.5	DFT-s-OFDM 16 QAM	1@1	23.82	18.47	0.0703
5	15	15	167300	836.5	DFT-s-OFDM QPSK	1@1	24.66	19.31	0.0853
5	15	15	167300	836.5	DFT-s-OFDM 16 QAM	1@1	23.72	18.37	0.0687
5	15	15	168300	841.5	DFT-s-OFDM QPSK	1@1	24.51	19.16	0.0824
5	15	15	168300	841.5	DFT-s-OFDM 16 QAM	1@1	23.57	18.22	0.0664
5	15	20	166800	834	DFT-s-OFDM PI/2 BPSK	50@25	24.27	18.92	0.0780
5	15	20	166800	834	DFT-s-OFDM PI/2 BPSK	1@1	24.37	19.02	0.0798
5	15	20	166800	834	DFT-s-OFDM PI/2 BPSK	1@104	24.19	18.84	0.0766
5	15	20	166800	834	DFT-s-OFDM QPSK	50@25	24.38	19.03	0.0800
5	15	20	166800	834	DFT-s-OFDM QPSK	1@1	24.89	19.54	0.0899
5	15	20	166800	834	DFT-s-OFDM QPSK	1@104	24.55	19.2	0.0832
5	15	20	166800	834	DFT-s-OFDM 16 QAM	50@25	23.62	18.27	0.0671
5	15	20	166800	834	DFT-s-OFDM 16 QAM	1@1	23.83	18.48	0.0705
5	15	20	166800	834	DFT-s-OFDM 16 QAM	1@104	23.43	18.08	0.0643
5	15	20	166800	834	DFT-s-OFDM 64 QAM	50@25	22.09	16.74	0.0472
5	15	20	166800	834	DFT-s-OFDM 64 QAM	1@1	22.16	16.81	0.0480

5	15	20	166800	834	DFT-s-OFDM 64 QAM	1@104	21.71	16.36	0.0433
5	15	20	166800	834	DFT-s-OFDM 256 QAM	50@25	20.18	14.83	0.0304
5	15	20	166800	834	DFT-s-OFDM 256 QAM	1@1	20.67	15.32	0.0340
5	15	20	166800	834	DFT-s-OFDM 256 QAM	1@104	20.14	14.79	0.0301
5	15	20	166800	834	CP-OFDM QPSK	53@26	23.1	17.75	0.0596
5	15	20	166800	834	CP-OFDM QPSK	1@1	23.85	18.5	0.0708
5	15	20	166800	834	CP-OFDM QPSK	1@104	23.38	18.03	0.0635
5	15	20	167300	836.5	DFT-s-OFDM PI/2 BPSK	50@25	24.31	18.96	0.0787
5	15	20	167300	836.5	DFT-s-OFDM PI/2 BPSK	1@1	24.38	19.03	0.0800
5	15	20	167300	836.5	DFT-s-OFDM PI/2 BPSK	1@104	24.21	18.86	0.0769
5	15	20	167300	836.5	DFT-s-OFDM QPSK	50@25	24.37	19.02	0.0798
5	15	20	167300	836.5	DFT-s-OFDM QPSK	1@1	24.75	19.4	0.0871
5	15	20	167300	836.5	DFT-s-OFDM QPSK	1@104	24.54	19.19	0.0830
5	15	20	167300	836.5	DFT-s-OFDM 16 QAM	50@25	23.58	18.23	0.0665
5	15	20	167300	836.5	DFT-s-OFDM 16 QAM	1@1	23.89	18.54	0.0714
5	15	20	167300	836.5	DFT-s-OFDM 16 QAM	1@104	23.61	18.26	0.0670
5	15	20	167300	836.5	DFT-s-OFDM 64 QAM	50@25	22.13	16.78	0.0476
5	15	20	167300	836.5	DFT-s-OFDM 64 QAM	1@1	22.12	16.77	0.0475
5	15	20	167300	836.5	DFT-s-OFDM 64 QAM	1@104	21.89	16.54	0.0451
5	15	20	167300	836.5	DFT-s-OFDM 256 QAM	50@25	19.98	14.63	0.0290
5	15	20	167300	836.5	DFT-s-OFDM 256 QAM	1@1	20.51	15.16	0.0328
5	15	20	167300	836.5	DFT-s-OFDM 256 QAM	1@104	20.25	14.9	0.0309
5	15	20	167300	836.5	CP-OFDM QPSK	53@26	23.04	17.69	0.0587
5	15	20	167300	836.5	CP-OFDM QPSK	1@1	23.82	18.47	0.0703
5	15	20	167300	836.5	CP-OFDM QPSK	1@104	23.53	18.18	0.0658
5	15	20	167800	839	DFT-s-OFDM PI/2 BPSK	50@25	24.23	18.88	0.0773
5	15	20	167800	839	DFT-s-OFDM PI/2 BPSK	1@1	24.31	18.96	0.0787
5	15	20	167800	839	DFT-s-OFDM PI/2 BPSK	1@104	24.14	18.79	0.0757
5	15	20	167800	839	DFT-s-OFDM QPSK	50@25	24.41	19.06	0.0805
5	15	20	167800	839	DFT-s-OFDM QPSK	1@1	24.67	19.32	0.0855
5	15	20	167800	839	DFT-s-OFDM QPSK	1@104	24.52	19.17	0.0826
5	15	20	167800	839	DFT-s-OFDM 16 QAM	50@25	23.56	18.21	0.0662
5	15	20	167800	839	DFT-s-OFDM 16 QAM	1@1	23.83	18.48	0.0705
5	15	20	167800	839	DFT-s-OFDM 16 QAM	1@104	23.6	18.25	0.0668
5	15	20	167800	839	DFT-s-OFDM 64 QAM	50@25	22.08	16.73	0.0471

5	15	20	167800	839	DFT-s-OFDM 64 QAM	1@1	22.07	16.72	0.0470
5	15	20	167800	839	DFT-s-OFDM 64 QAM	1@104	21.92	16.57	0.0454
5	15	20	167800	839	DFT-s-OFDM 256 QAM	50@25	20.32	14.97	0.0314
5	15	20	167800	839	DFT-s-OFDM 256 QAM	1@1	20.44	15.09	0.0323
5	15	20	167800	839	DFT-s-OFDM 256 QAM	1@104	20.23	14.88	0.0308
5	15	20	167800	839	CP-OFDM QPSK	53@26	23.56	18.21	0.0662
5	15	20	167800	839	CP-OFDM QPSK	1@1	23.79	18.44	0.0698
5	15	20	167800	839	CP-OFDM QPSK	1@104	23.61	18.26	0.0670

FR1 N5 (ANT0) - SCS 30k

Transmitter Conducted Output Power And ERP, ($G_T - L_C$)=-4.1dB

NR Band	SCS	BandWidth	Arfcn	Freq(MHz)	Modulation	RB	Conducted Power(dBm)	ERP(dBm)	ERP(W)
5	30	10	165800	829	DFT-s-OFDM QPSK	1@1	25.61	19.36	0.0863
5	30	10	165800	829	DFT-s-OFDM 16 QAM	1@1	24.5	18.25	0.0668
5	30	10	167300	836.5	DFT-s-OFDM QPSK	1@1	25.53	19.28	0.0847
5	30	10	167300	836.5	DFT-s-OFDM 16 QAM	1@1	24.37	18.12	0.0649
5	30	10	168800	844	DFT-s-OFDM QPSK	1@1	25.43	19.18	0.0828
5	30	10	168800	844	DFT-s-OFDM 16 QAM	1@1	24.16	17.91	0.0618
5	30	15	166300	831.5	DFT-s-OFDM QPSK	1@1	25.61	19.36	0.0863
5	30	15	166300	831.5	DFT-s-OFDM 16 QAM	1@1	24.5	18.25	0.0668
5	30	15	167300	836.5	DFT-s-OFDM QPSK	1@1	25.36	19.11	0.0815
5	30	15	167300	836.5	DFT-s-OFDM 16 QAM	1@1	24.42	18.17	0.0656
5	30	15	168300	841.5	DFT-s-OFDM QPSK	1@1	25.16	18.91	0.0778
5	30	15	168300	841.5	DFT-s-OFDM 16 QAM	1@1	24.21	17.96	0.0625
5	30	20	166800	834	DFT-s-OFDM PI/2 BPSK	25@12	25.16	18.91	0.0778
5	30	20	166800	834	DFT-s-OFDM PI/2 BPSK	1@1	25.29	19.04	0.0802
5	30	20	166800	834	DFT-s-OFDM PI/2 BPSK	1@49	25	18.75	0.0750
5	30	20	166800	834	DFT-s-OFDM QPSK	25@12	25.2	18.95	0.0785
5	30	20	166800	834	DFT-s-OFDM QPSK	1@1	25.46	19.21	0.0834
5	30	20	166800	834	DFT-s-OFDM QPSK	1@49	25.33	19.08	0.0809
5	30	20	166800	834	DFT-s-OFDM 16 QAM	25@12	24.45	18.2	0.0661
5	30	20	166800	834	DFT-s-OFDM 16 QAM	1@1	24.53	18.28	0.0673
5	30	20	166800	834	DFT-s-OFDM 16 QAM	1@49	24.16	17.91	0.0618
5	30	20	166800	834	DFT-s-OFDM 64 QAM	25@12	22.91	16.66	0.0463
5	30	20	166800	834	DFT-s-OFDM 64 QAM	1@1	22.88	16.63	0.0460
5	30	20	166800	834	DFT-s-OFDM 64 QAM	1@49	22.46	16.21	0.0418
5	30	20	166800	834	DFT-s-OFDM 256 QAM	25@12	20.87	14.62	0.0290
5	30	20	166800	834	DFT-s-OFDM 256 QAM	1@1	21.29	15.04	0.0319
5	30	20	166800	834	DFT-s-OFDM 256 QAM	1@49	20.93	14.68	0.0294
5	30	20	166800	834	CP-OFDM QPSK	25@12	23.94	17.69	0.0587
5	30	20	166800	834	CP-OFDM QPSK	1@1	23.94	17.69	0.0587
5	30	20	166800	834	CP-OFDM QPSK	1@49	23.56	17.31	0.0538
5	30	20	167300	836.5	DFT-s-OFDM PI/2 BPSK	25@12	25.11	18.86	0.0769
5	30	20	167300	836.5	DFT-s-OFDM PI/2 BPSK	1@1	25.18	18.93	0.0782
5	30	20	167300	836.5	DFT-s-OFDM PI/2 BPSK	1@49	24.96	18.71	0.0743
5	30	20	167300	836.5	DFT-s-OFDM QPSK	25@12	25.24	18.99	0.0793
5	30	20	167300	836.5	DFT-s-OFDM QPSK	1@1	25.62	19.37	0.0865
5	30	20	167300	836.5	DFT-s-OFDM QPSK	1@49	25.45	19.2	0.0832
5	30	20	167300	836.5	DFT-s-OFDM 16 QAM	25@12	24.47	18.22	0.0664
5	30	20	167300	836.5	DFT-s-OFDM 16 QAM	1@1	24.52	18.27	0.0671

5	30	20	167300	836.5	DFT-s-OFDM 16 QAM	1@49	24.24	17.99	0.0630
5	30	20	167300	836.5	DFT-s-OFDM 64 QAM	25@12	22.86	16.61	0.0458
5	30	20	167300	836.5	DFT-s-OFDM 64 QAM	1@1	22.82	16.57	0.0454
5	30	20	167300	836.5	DFT-s-OFDM 64 QAM	1@49	22.54	16.29	0.0426
5	30	20	167300	836.5	DFT-s-OFDM 256 QAM	25@12	20.82	14.57	0.0286
5	30	20	167300	836.5	DFT-s-OFDM 256 QAM	1@1	21.28	15.03	0.0318
5	30	20	167300	836.5	DFT-s-OFDM 256 QAM	1@49	20.96	14.71	0.0296
5	30	20	167300	836.5	CP-OFDM QPSK	25@12	23.88	17.63	0.0579
5	30	20	167300	836.5	CP-OFDM QPSK	1@1	23.85	17.6	0.0575
5	30	20	167300	836.5	CP-OFDM QPSK	1@49	23.52	17.27	0.0533
5	30	20	167800	839	DFT-s-OFDM PI/2 BPSK	25@12	25.08	18.83	0.0764
5	30	20	167800	839	DFT-s-OFDM PI/2 BPSK	1@1	25.13	18.88	0.0773
5	30	20	167800	839	DFT-s-OFDM PI/2 BPSK	1@49	24.93	18.68	0.0738
5	30	20	167800	839	DFT-s-OFDM QPSK	25@12	25.19	18.94	0.0783
5	30	20	167800	839	DFT-s-OFDM QPSK	1@1	25.56	19.31	0.0853
5	30	20	167800	839	DFT-s-OFDM QPSK	1@49	25.55	19.3	0.0851
5	30	20	167800	839	DFT-s-OFDM 16 QAM	25@12	24.37	18.12	0.0649
5	30	20	167800	839	DFT-s-OFDM 16 QAM	1@1	24.36	18.11	0.0647
5	30	20	167800	839	DFT-s-OFDM 16 QAM	1@49	24.24	17.99	0.0630
5	30	20	167800	839	DFT-s-OFDM 64 QAM	25@12	22.8	16.55	0.0452
5	30	20	167800	839	DFT-s-OFDM 64 QAM	1@1	22.87	16.62	0.0459
5	30	20	167800	839	DFT-s-OFDM 64 QAM	1@49	22.69	16.44	0.0441
5	30	20	167800	839	DFT-s-OFDM 256 QAM	25@12	20.79	14.54	0.0284
5	30	20	167800	839	DFT-s-OFDM 256 QAM	1@1	21.21	14.96	0.0313
5	30	20	167800	839	DFT-s-OFDM 256 QAM	1@49	20.95	14.7	0.0295
5	30	20	167800	839	CP-OFDM QPSK	25@12	23.8	17.55	0.0569
5	30	20	167800	839	CP-OFDM QPSK	1@1	23.74	17.49	0.0561
5	30	20	167800	839	CP-OFDM QPSK	1@49	23.57	17.32	0.0540

FR1 N5 (ANT1) - SCS 15k

Frequency Stability

NR Band	SCS (kHz)	Bandwidth (MHz)	Arfcn	Freq (MHz)	Modulation	RB	Deviation (ppm)	Verdict	Environment
5	15	20	167300	836.5	DFT-s-OFDM QPSK	100@0	0.0034	PASS	NV
5	15	20	167300	836.5	DFT-s-OFDM QPSK	100@0	0.0025	PASS	LV
5	15	20	167300	836.5	DFT-s-OFDM QPSK	100@0	0.0040	PASS	HV
5	15	20	167300	836.5	DFT-s-OFDM QPSK	100@0	0.0051	PASS	-30°C
5	15	20	167300	836.5	DFT-s-OFDM QPSK	100@0	0.0045	PASS	-20°C
5	15	20	167300	836.5	DFT-s-OFDM QPSK	100@0	0.0032	PASS	-10°C
5	15	20	167300	836.5	DFT-s-OFDM QPSK	100@0	0.0061	PASS	0°C
5	15	20	167300	836.5	DFT-s-OFDM QPSK	100@0	0.0033	PASS	10°C
5	15	20	167300	836.5	DFT-s-OFDM QPSK	100@0	0.0034	PASS	20°C
5	15	20	167300	836.5	DFT-s-OFDM QPSK	100@0	0.0037	PASS	30°C
5	15	20	167300	836.5	DFT-s-OFDM QPSK	100@0	0.0067	PASS	40°C
5	15	20	167300	836.5	DFT-s-OFDM QPSK	100@0	0.0045	PASS	50°C

Peak to Average Ratio

NR Band	SCS (kHz)	Bandwidth (MHz)	Arfcn	Freq (MHz)	Modulation	RB	Result (dB)	Limit (dB)	Verdict
5	15	20	167300	836.5	DFT-s-OFDM PI/2 BPSK	100@0	4.01	13	PASS
5	15	20	167300	836.5	DFT-s-OFDM QPSK	100@0	5.04	13	PASS

N5(20M)_DFT-s-OFDM_PI_2-BPSK_Outer_Full_Mid_CH



N5(20M)_DFT-s-OFDM_QPSK_Outer_Full_Mid_CH



Occupied Bandwidth

NR Band	SCS (kHz)	Bandwidth (MHz)	Arfcn	Freq (MHz)	Modulation	RB	OBW (MHz)	26dB BW (MHz)
5	15	5	167300	836.5	CP-OFDM QPSK	25@0	4.4664	4.826
5	15	5	167300	836.5	CP-OFDM 16 QAM	25@0	4.4626	4.793
5	15	5	167300	836.5	CP-OFDM 64 QAM	25@0	4.4768	4.784
5	15	5	167300	836.5	CP-OFDM 256 QAM	25@0	4.4646	4.788
5	15	10	167300	836.5	CP-OFDM QPSK	52@0	9.2759	9.75
5	15	10	167300	836.5	CP-OFDM 16 QAM	52@0	9.2913	9.705
5	15	10	167300	836.5	CP-OFDM 64 QAM	52@0	9.2839	9.724
5	15	10	167300	836.5	CP-OFDM 256 QAM	52@0	9.2562	9.713
5	15	15	167300	836.5	CP-OFDM QPSK	79@0	14.068	14.71
5	15	15	167300	836.5	CP-OFDM 16 QAM	79@0	14.115	14.69
5	15	15	167300	836.5	CP-OFDM 64 QAM	79@0	14.063	14.73
5	15	15	167300	836.5	CP-OFDM 256 QAM	79@0	14.05	14.68
5	15	20	167300	836.5	CP-OFDM QPSK	106@0	18.921	19.65
5	15	20	167300	836.5	CP-OFDM 16 QAM	106@0	18.903	19.62
5	15	20	167300	836.5	CP-OFDM 64 QAM	106@0	18.969	19.62
5	15	20	167300	836.5	CP-OFDM 256 QAM	106@0	18.964	19.57

N5(5M)_CP-OFDM_QPSK_Outer_Full_Mid_CH

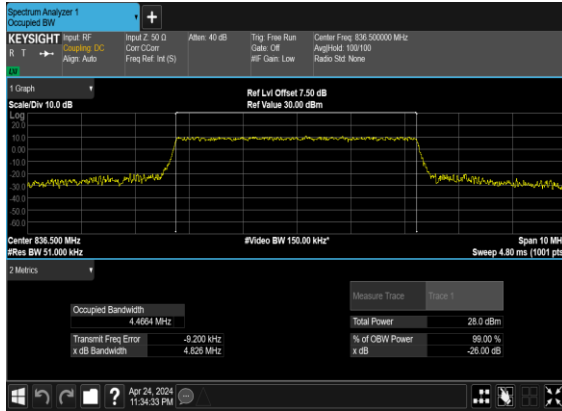

N5(5M)_CP-OFDM_16QAM_Outer_Full_Mid_CH

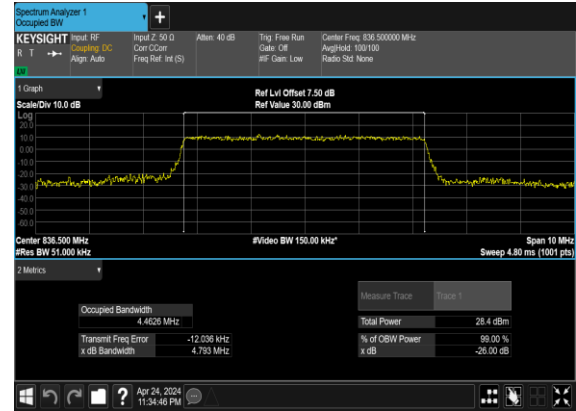

N5(5M)_CP-OFDM_64QAM_Outer_Full_Mid_CH



N5(5M)_CP-OFDM_256QAM_Outer_Full_Mid_CH

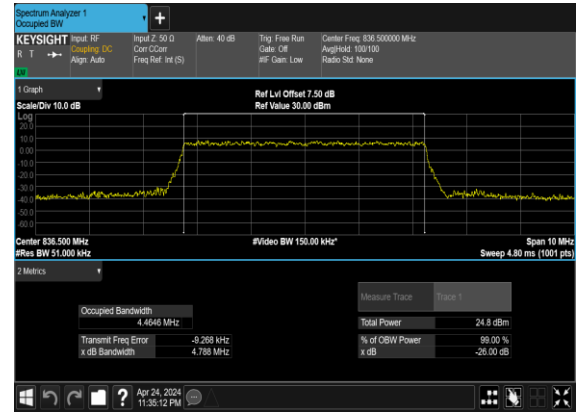

N5(10M)_CP-OFDM_QPSK_Outer_Full_Mid_CH

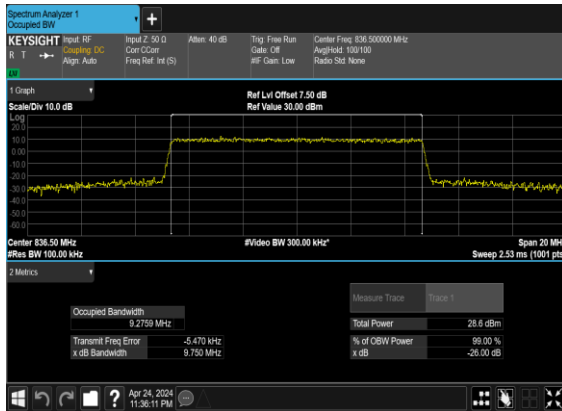

N5(10M)_CP-OFDM_16QAM_Outer_Full_Mid_CH

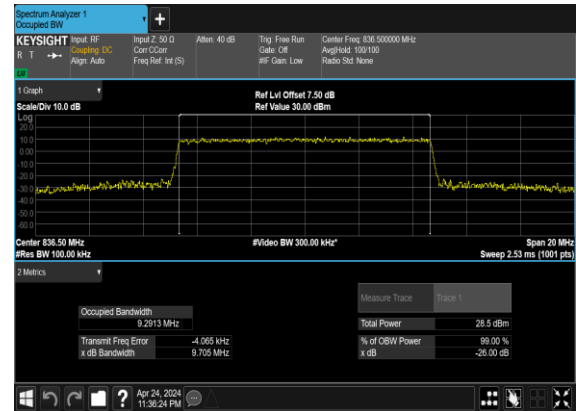

N5(10M)_CP-OFDM_64 QAM_Outer_Full_Mid_CH

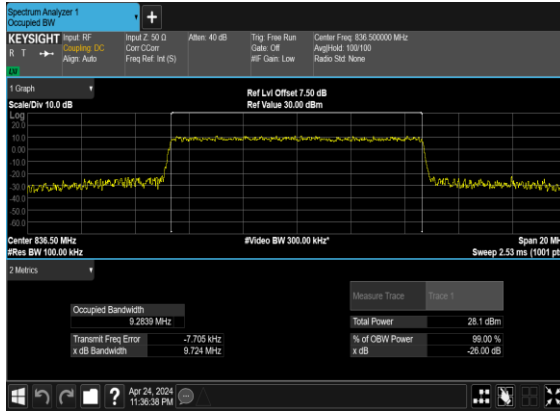

N5(10M)_CP-OFDM_256 QAM_Outer_Full_Mid_CH

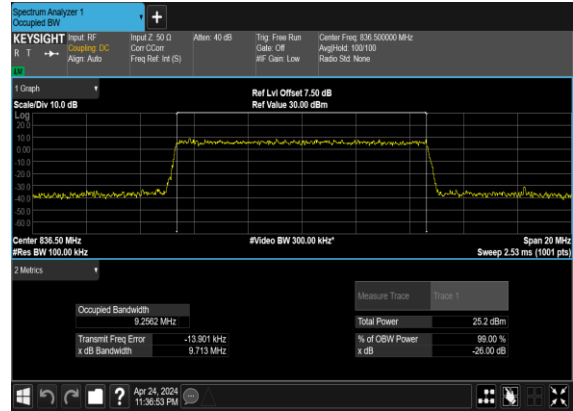

N5(15M)_CP- OFDM_QPSK_Outer_Full_Mid_CH

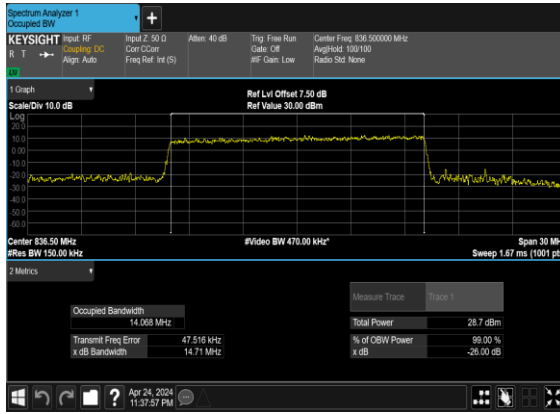

N5(15M)_CP-OFDM_16 QAM_Outer_Full_Mid_CH

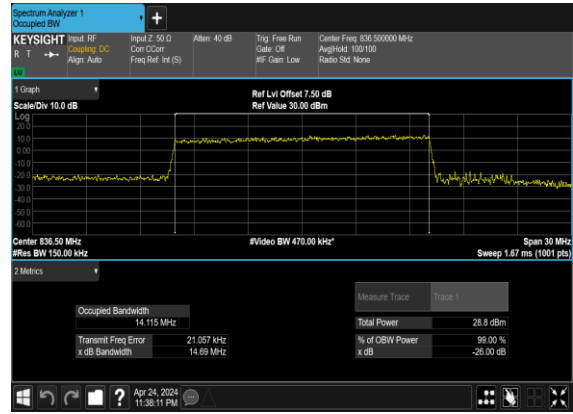

N5(15M)_CP-OFDM_64 QAM_Outer_Full_Mid_CH

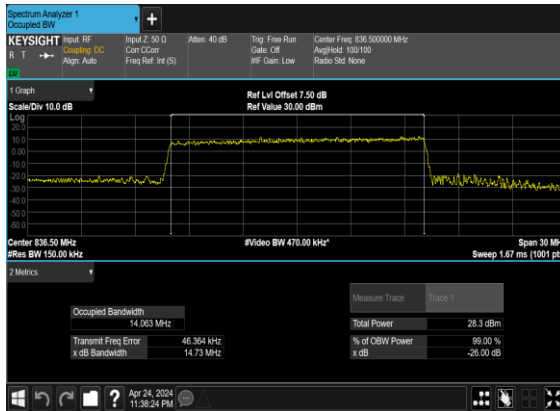

N5(15M)_CP-OFDM_256 QAM_Outer_Full_Mid_CH

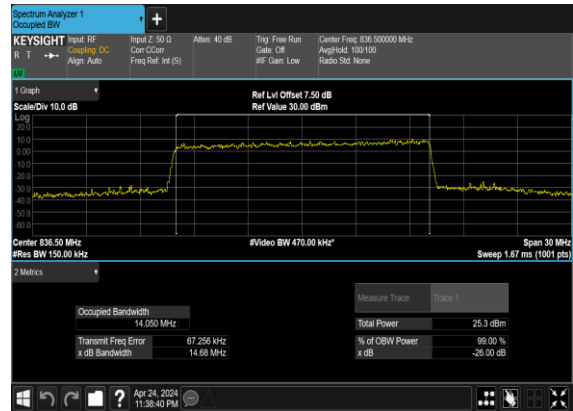

N5(20M)_CP-OFDM_QPSK_Outer_Full_Mid_CH

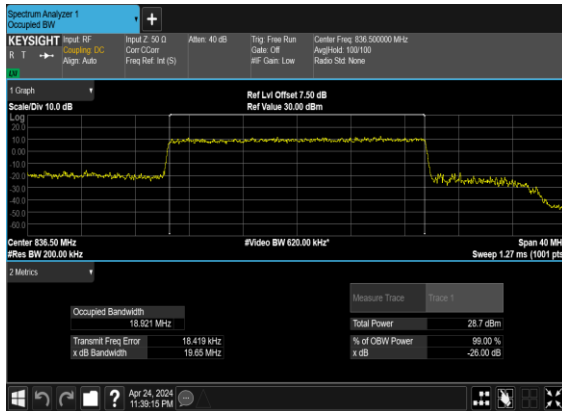

N5(20M)_CP-OFDM_16QAM_Outer_Full_Mid_CH

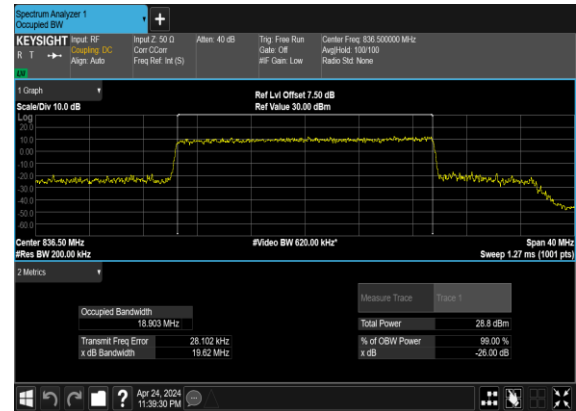

N5(20M)_CP-OFDM_64QAM_Outer_Full_Mid_CH

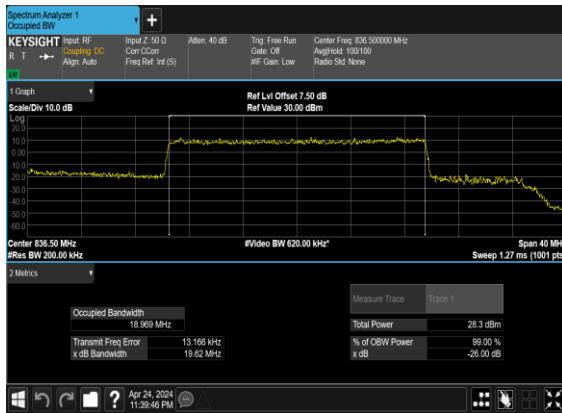

N5(20M)_CP-OFDM_256QAM_Outer_Full_Mid_CH

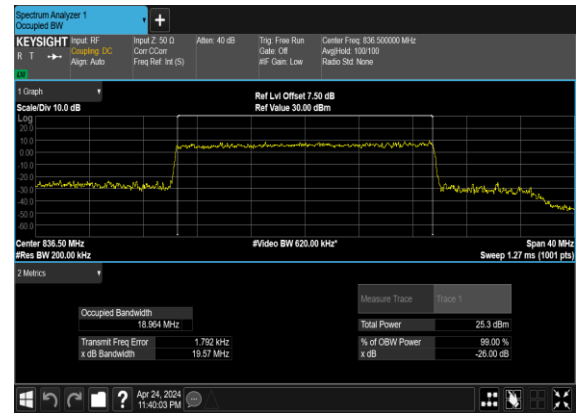

Conducted Spurious Emissions

NR Band	SCS (kHz)	Bandwidth (MHz)	Arfcn	Freq (MHz)	Modulation	RB	Result	Verdict
5	15	5	165300	826.5	DFT-s-OFDM BPSK	1@0	see graph	---
5	15	5	165300	826.5	DFT-s-OFDM BPSK	1@0	see graph	PASS
5	15	5	165300	826.5	DFT-s-OFDM QPSK	1@0	see graph	---
5	15	5	165300	826.5	DFT-s-OFDM QPSK	1@0	see graph	PASS
5	15	5	167300	836.5	DFT-s-OFDM BPSK	1@0	see graph	---
5	15	5	167300	836.5	DFT-s-OFDM BPSK	1@0	see graph	PASS
5	15	5	167300	836.5	DFT-s-OFDM QPSK	1@0	see graph	---
5	15	5	167300	836.5	DFT-s-OFDM QPSK	1@0	see graph	PASS
5	15	5	169300	846.5	DFT-s-OFDM BPSK	1@0	see graph	---
5	15	5	169300	846.5	DFT-s-OFDM BPSK	1@0	see graph	PASS
5	15	5	169300	846.5	DFT-s-OFDM QPSK	1@0	see graph	---
5	15	5	169300	846.5	DFT-s-OFDM QPSK	1@0	see graph	PASS
5	15	10	165800	829.0	DFT-s-OFDM BPSK	1@0	see graph	---
5	15	10	165800	829.0	DFT-s-OFDM BPSK	1@0	see graph	PASS
5	15	10	165800	829.0	DFT-s-OFDM QPSK	1@0	see graph	---
5	15	10	165800	829.0	DFT-s-OFDM QPSK	1@0	see graph	PASS
5	15	10	167300	836.5	DFT-s-OFDM BPSK	1@0	see graph	---
5	15	10	167300	836.5	DFT-s-OFDM BPSK	1@0	see graph	PASS
5	15	10	167300	836.5	DFT-s-OFDM QPSK	1@0	see graph	---
5	15	10	167300	836.5	DFT-s-OFDM QPSK	1@0	see graph	PASS
5	15	10	168800	844.0	DFT-s-OFDM BPSK	1@0	see graph	---
5	15	10	168800	844.0	DFT-s-OFDM BPSK	1@0	see graph	PASS
5	15	10	168800	844.0	DFT-s-OFDM QPSK	1@0	see graph	---
5	15	10	168800	844.0	DFT-s-OFDM QPSK	1@0	see graph	PASS
5	15	20	166800	834.0	DFT-s-OFDM BPSK	1@0	see graph	---

5	15	20	166800	834.0	DFT-s-OFDM BPSK	1@0	see graph	PASS
5	15	20	166800	834.0	DFT-s-OFDM QPSK	1@0	see graph	---
5	15	20	166800	834.0	DFT-s-OFDM QPSK	1@0	see graph	PASS
5	15	20	167300	836.5	DFT-s-OFDM BPSK	1@0	see graph	---
5	15	20	167300	836.5	DFT-s-OFDM BPSK	1@0	see graph	PASS
5	15	20	167300	836.5	DFT-s-OFDM QPSK	1@0	see graph	---
5	15	20	167300	836.5	DFT-s-OFDM QPSK	1@0	see graph	PASS
5	15	20	167800	839.0	DFT-s-OFDM BPSK	1@0	see graph	---
5	15	20	167800	839.0	DFT-s-OFDM BPSK	1@0	see graph	PASS
5	15	20	167800	839.0	DFT-s-OFDM QPSK	1@0	see graph	---
5	15	20	167800	839.0	DFT-s-OFDM QPSK	1@0	see graph	PASS

N5(5M)_DFT-s-OFDM_BPSK_Edge_1RB_Left_Low_CH

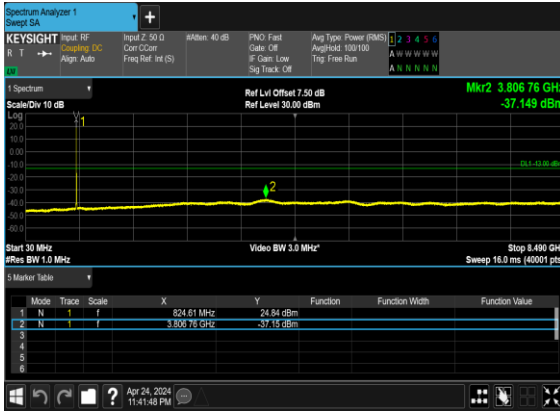

N5(5M)_DFT-s-OFDM_QPSK_Edge_1RB_Left_Low_CH

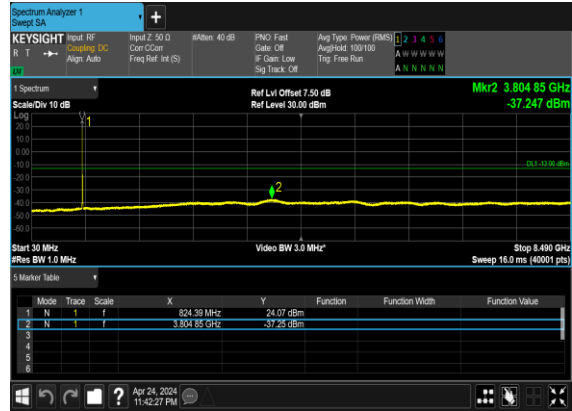

N5(5M)_DFT-s-OFDM_BPSK_Edge_1RB_Left_Mid_CH

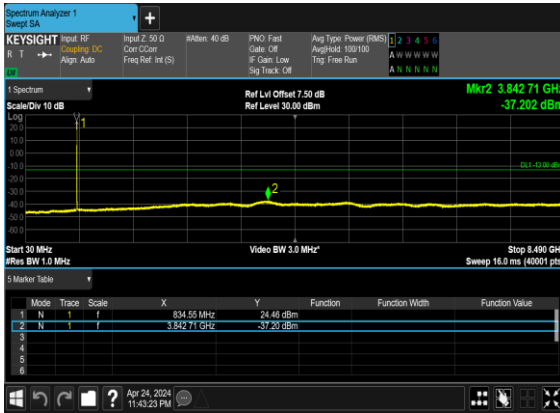

N5(5M)_DFT-s-OFDM_QPSK_Edge_1RB_Left_Mid_CH

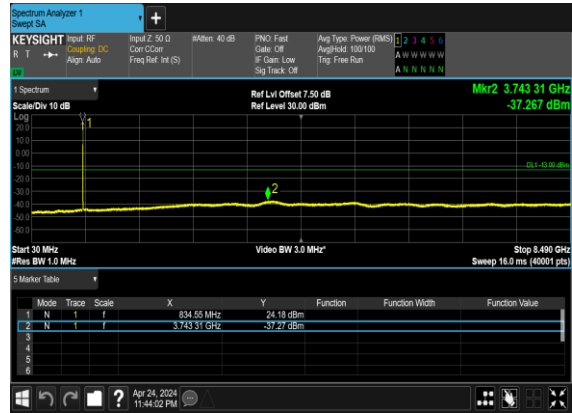

N5(5M)_DFT-s-OFDM_BPSK_Edge_1RB_Left_High_CH



N5(5M)_DFT-s-OFDM_QPSK_Edge_1RB_Left_High_CH

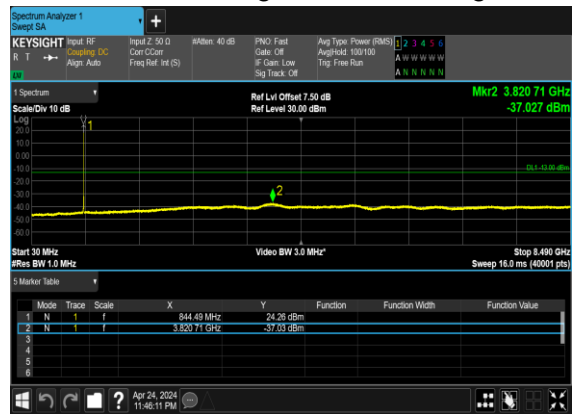

N5(10M)_DFT-s-OFDM_BPSK_Edge_1RB_Left_Low_CH

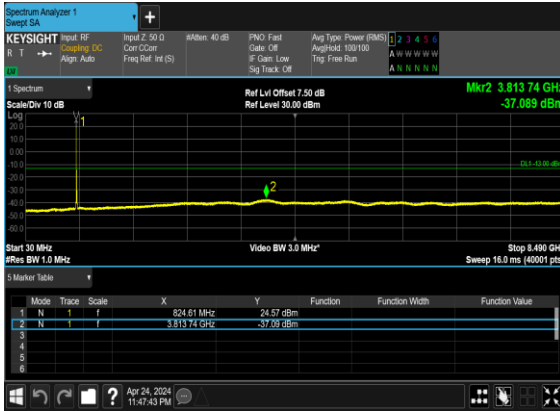

N5(10M)_DFT-s-OFDM_QPSK_Edge_1RB_Left_Low_CH

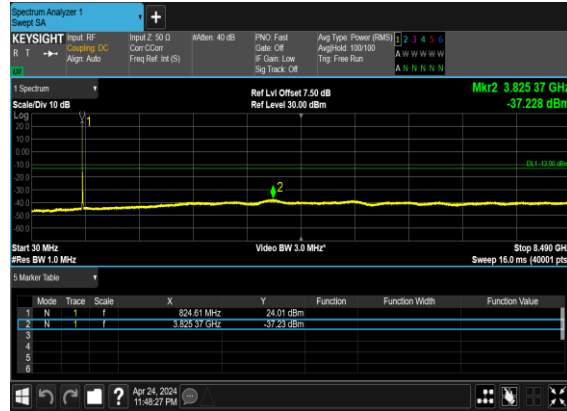

N5(10M)_DFT-s-OFDM_BPSK_Edge_1RB_Left_Mid_CH

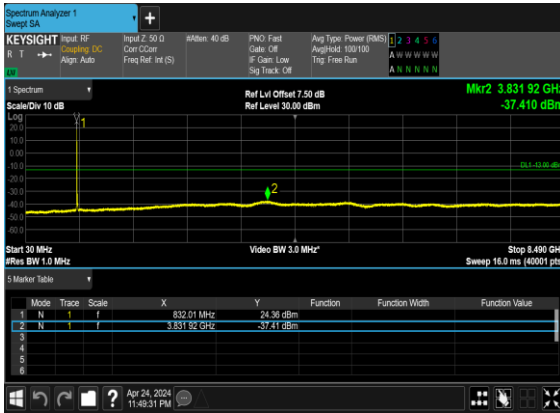

N5(10M)_DFT-s-OFDM_QPSK_Edge_1RB_Left_Mid_CH

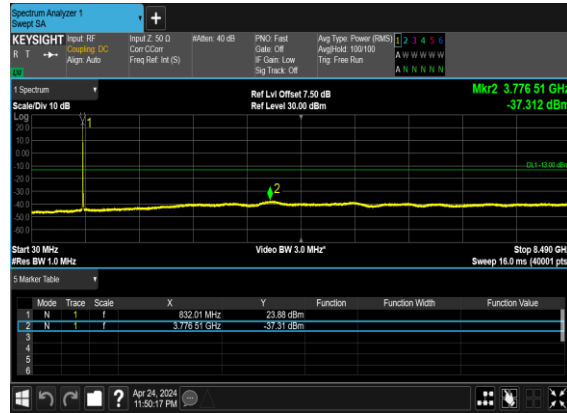

N5(10M)_DFT-s-OFDM_BPSK_Edge_1RB_Left_High_CH

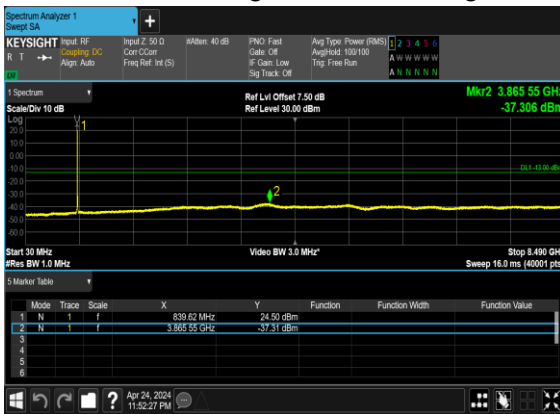

N5(10M)_DFT-s-OFDM_QPSK_Edge_1RB_Left_High_CH

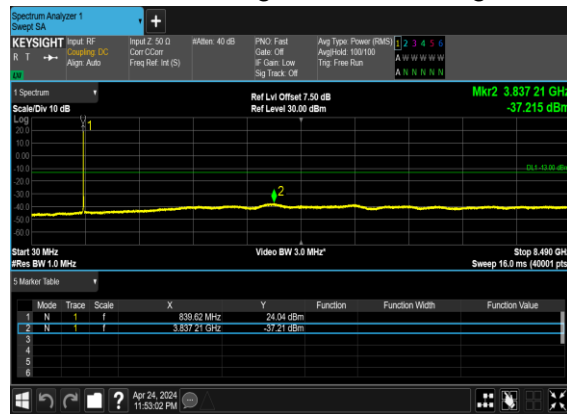

N5(20M)_DFT-s-
OFDM_BPSK_Edge_1RB_Left_Low_CH



N5(20M)_DFT-s-
OFDM_QPSK_Edge_1RB_Left_Low_CH



N5(20M)_DFT-s-
OFDM_BPSK_Edge_1RB_Left_Mid_CH

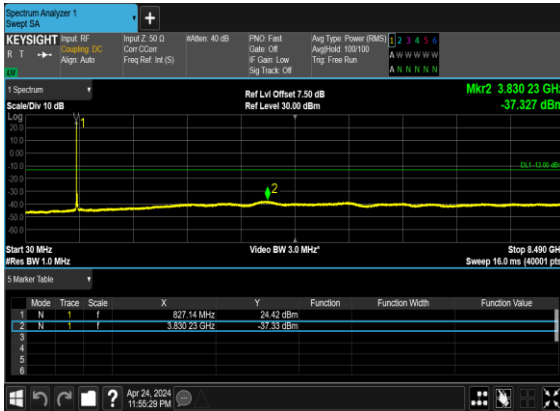

N5(20M)_DFT-s-
OFDM_QPSK_Edge_1RB_Left_Mid_CH

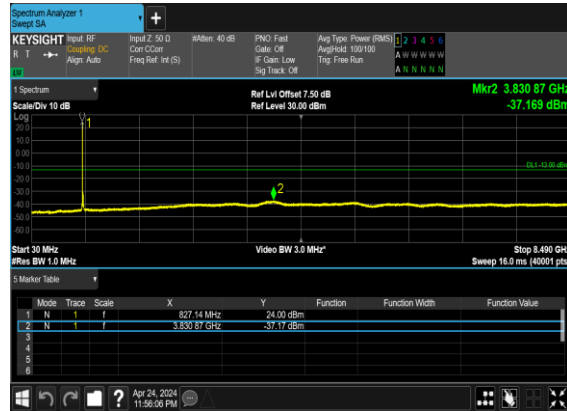

N5(20M)_DFT-s-
OFDM_BPSK_Edge_1RB_Left_High_CH

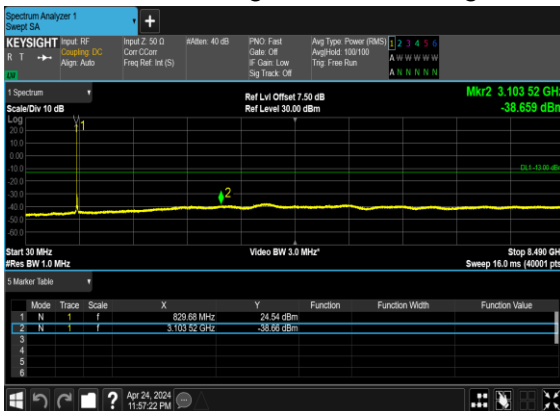

N5(20M)_DFT-s-
OFDM_QPSK_Edge_1RB_Left_High_CH

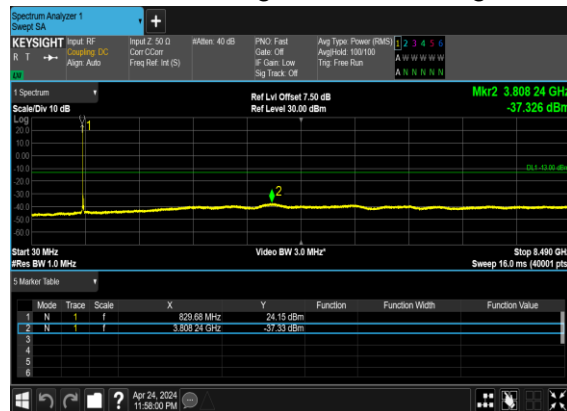

Conducted Band Edge

NR Band	SCS (kHz)	Bandwidth (MHz)	Arfcn	Freq (MHz)	Modulation	RB	Result	Verdict
5	15	5	165300	826.5	DFT-s-OFDM BPSK	1@0	see graph	PASS
5	15	5	165300	826.5	DFT-s-OFDM QPSK	1@0	see graph	PASS
5	15	5	165300	826.5	DFT-s-OFDM BPSK	25@0	see graph	PASS
5	15	5	165300	826.5	DFT-s-OFDM QPSK	25@0	see graph	PASS
5	15	5	169300	846.5	DFT-s-OFDM BPSK	1@24	see graph	PASS
5	15	5	169300	846.5	DFT-s-OFDM QPSK	1@24	see graph	PASS
5	15	5	169300	846.5	DFT-s-OFDM BPSK	25@0	see graph	PASS
5	15	5	169300	846.5	DFT-s-OFDM QPSK	25@0	see graph	PASS
5	15	10	165800	829.0	DFT-s-OFDM BPSK	1@0	see graph	PASS
5	15	10	165800	829.0	DFT-s-OFDM QPSK	1@0	see graph	PASS
5	15	10	165800	829.0	DFT-s-OFDM BPSK	50@0	see graph	PASS
5	15	10	165800	829.0	DFT-s-OFDM QPSK	50@0	see graph	PASS
5	15	10	168800	844.0	DFT-s-OFDM BPSK	1@51	see graph	PASS
5	15	10	168800	844.0	DFT-s-OFDM QPSK	1@51	see graph	PASS
5	15	10	168800	844.0	DFT-s-OFDM BPSK	50@0	see graph	PASS
5	15	10	168800	844.0	DFT-s-OFDM QPSK	50@0	see graph	PASS
5	15	20	166800	834.0	DFT-s-OFDM BPSK	1@0	see graph	PASS
5	15	20	166800	834.0	DFT-s-OFDM QPSK	1@0	see graph	PASS
5	15	20	166800	834.0	DFT-s-OFDM BPSK	100@0	see graph	PASS
5	15	20	166800	834.0	DFT-s-OFDM QPSK	100@0	see graph	PASS
5	15	20	167800	839.0	DFT-s-OFDM BPSK	1@105	see graph	PASS
5	15	20	167800	839.0	DFT-s-OFDM QPSK	1@105	see graph	PASS
5	15	20	167800	839.0	DFT-s-OFDM BPSK	100@0	see graph	PASS
5	15	20	167800	839.0	DFT-s-OFDM QPSK	100@0	see graph	PASS

N5(5M)_DFT-s- OFDM_BPSK_Edge_1RB_Left_Low_CH

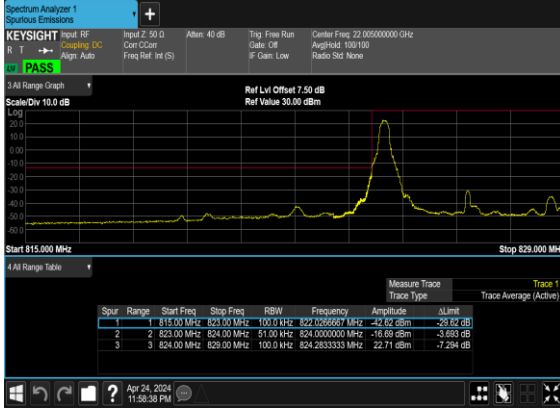

N5(5M)_DFT-s- OFDM_QPSK_Edge_1RB_Left_Low_CH

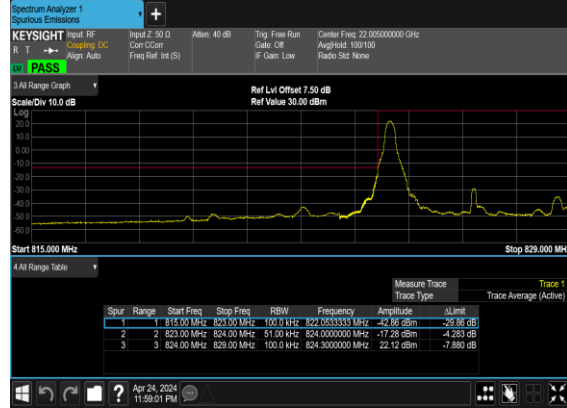

N5(5M)_DFT-s- OFDM_BPSK_Outer_Full_Low_CH



N5(5M)_DFT-s- OFDM_QPSK_Outer_Full_Low_CH

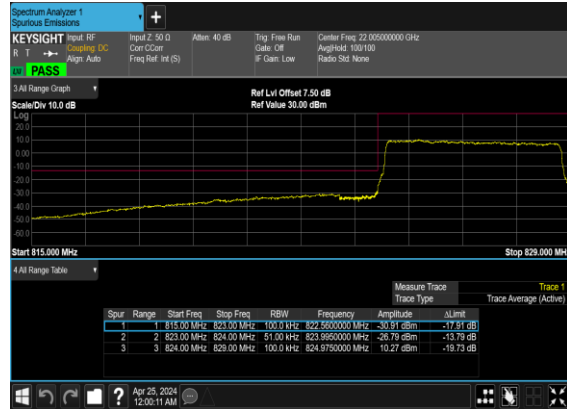

N5(5M)_DFT-s- OFDM_BPSK_Edge_1RB_Right_High_CH

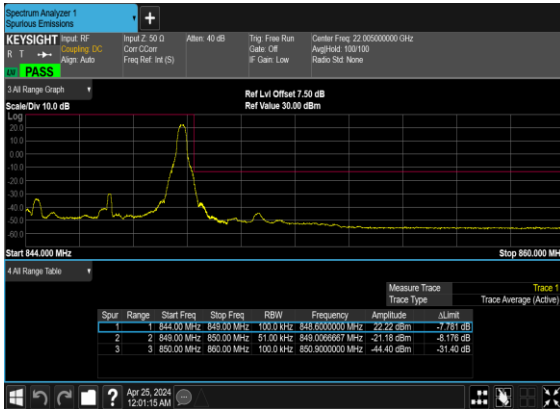

N5(5M)_DFT-s- OFDM_QPSK_Edge_1RB_Right_High_CH

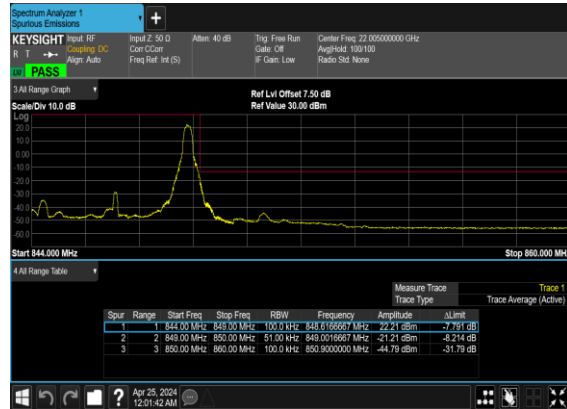

N5(5M)_DFT-s-
OFDM_BPSK_Outer_Full_High_CH

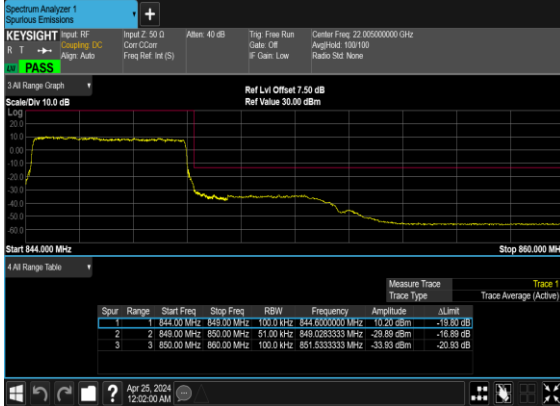

N5(5M)_DFT-s-
OFDM_QPSK_Outer_Full_High_CH

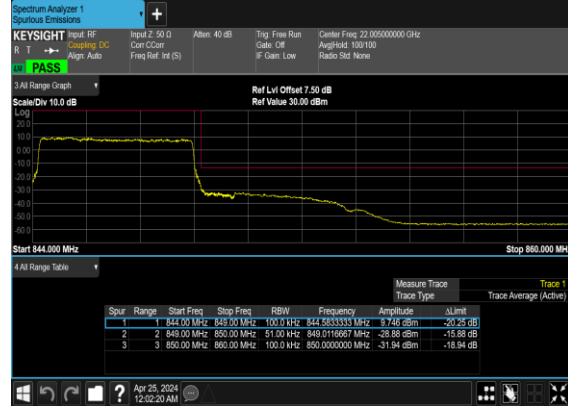

N5(10M)_DFT-s-
OFDM_BPSK_Edge_1RB_Left_Low_CH

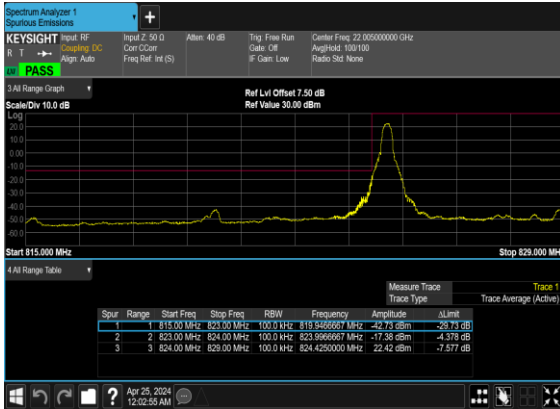

N5(10M)_DFT-s-
OFDM_QPSK_Edge_1RB_Left_Low_CH

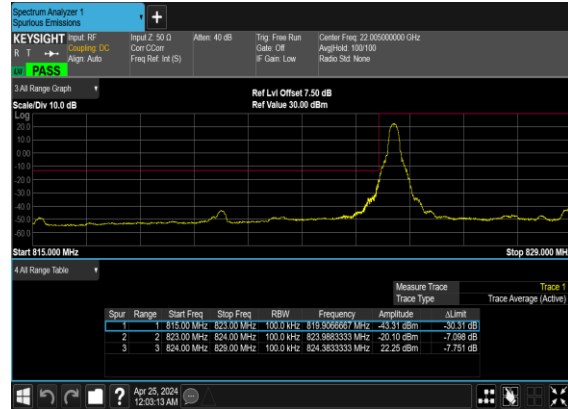

N5(10M)_DFT-s-
OFDM_BPSK_Outer_Full_Low_CH

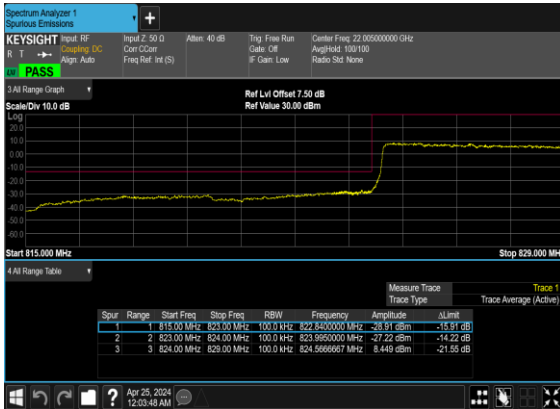

N5(10M)_DFT-s-
OFDM_QPSK_Outer_Full_Low_CH

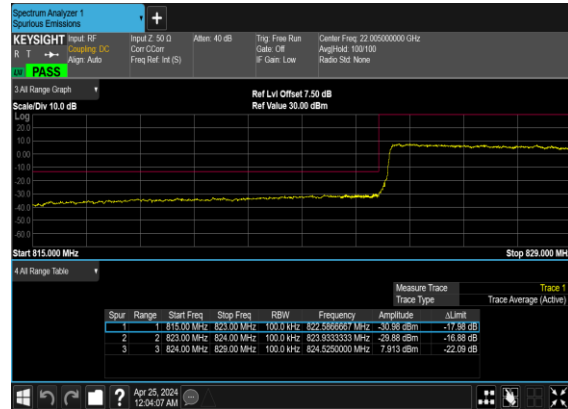

N5(10M)_DFT-s-
OFDM_BPSK_Edge_1RB_Right_High_CH

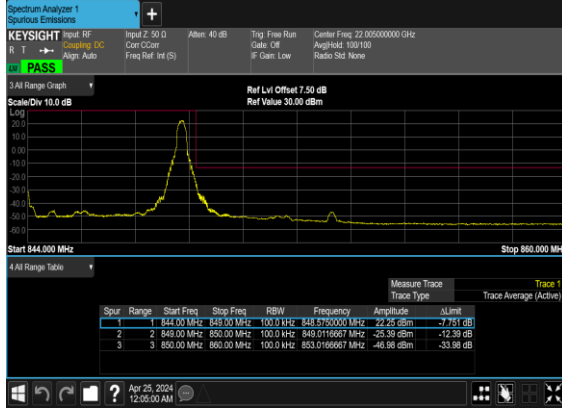

N5(10M)_DFT-s-
OFDM_QPSK_Edge_1RB_Right_High_CH

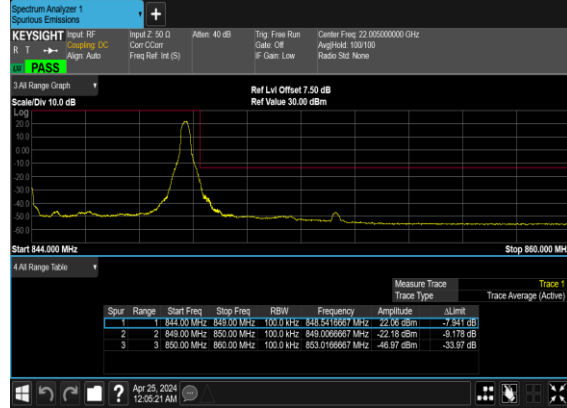

N5(10M)_DFT-s-
OFDM_BPSK_Outer_Full_High_CH



N5(10M)_DFT-s-
OFDM_QPSK_Outer_Full_High_CH

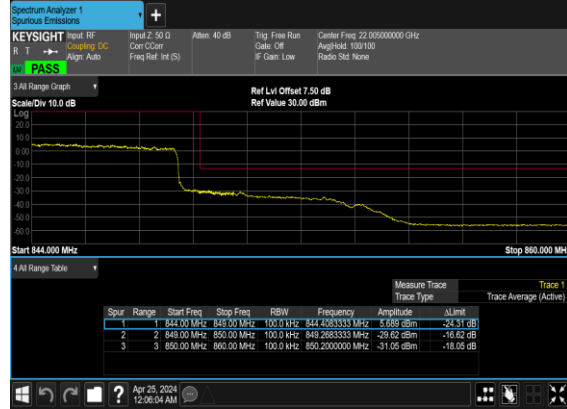

N5(20M)_DFT-s-
OFDM_BPSK_Edge_1RB_Left_Low_CH

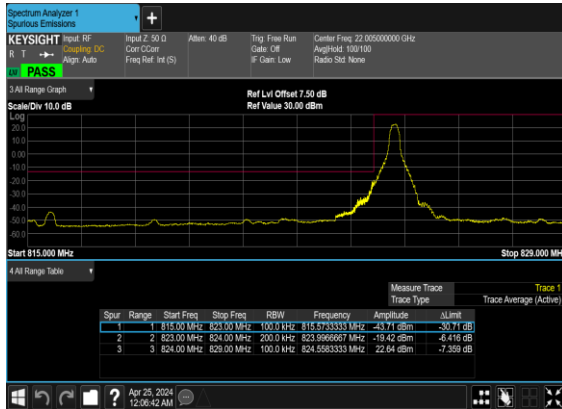

N5(20M)_DFT-s-
OFDM_QPSK_Edge_1RB_Left_Low_CH

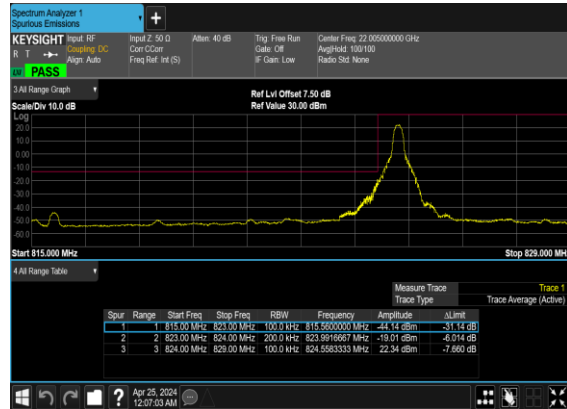

N5(20M)_DFT-s-
OFDM_BPSK_Outer_Full_Low_CH

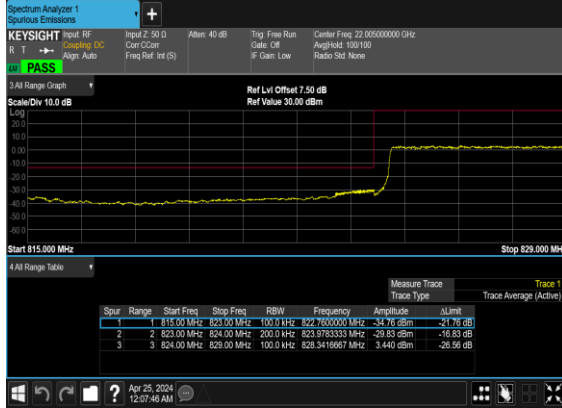

N5(20M)_DFT-s-
OFDM_QPSK_Outer_Full_Low_CH

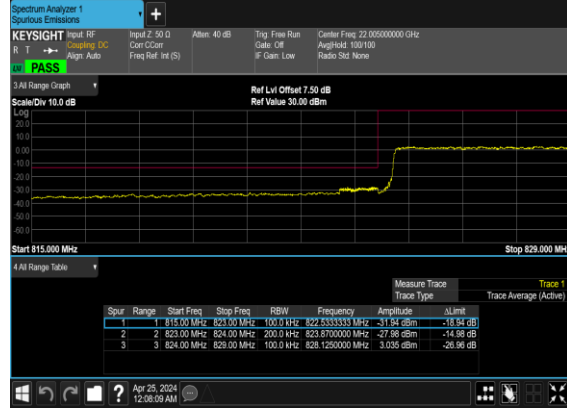

N5(20M)_DFT-s-
OFDM_BPSK_Edge_1RB_Right_High_CH

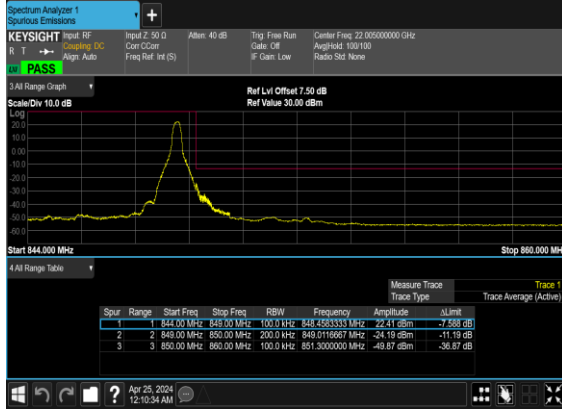

N5(20M)_DFT-s-
OFDM_QPSK_Edge_1RB_Right_High_CH

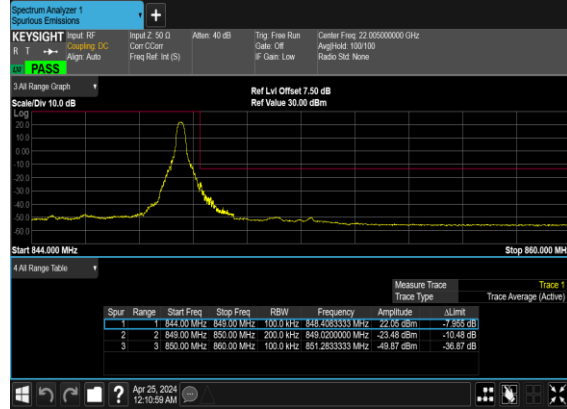

N5(20M)_DFT-s-
OFDM_BPSK_Outer_Full_High_CH



N5(20M)_DFT-s-
OFDM_QPSK_Outer_Full_High_CH



FR1 N12(ANT0) - SCS 15k

Transmitter Conducted Output Power And ERP, (G_T - L_C)=-4.1dB

NR Band	SCS (kHz)	Bandwidth (MHz)	Arfcn	Freq (MHz)	Modulation	RB	Conducted Power(dBm)	ERP (dBm)	ERP (W)
12	15	5	140300	701.5	DFT-s-OFDM QPSK	1@1	24.93	18.68	0.0738
12	15	5	140300	701.5	DFT-s-OFDM 16 QAM	1@1	24.23	17.98	0.0628
12	15	5	141500	707.5	DFT-s-OFDM QPSK	1@1	24.94	18.69	0.0740
12	15	5	141500	707.5	DFT-s-OFDM 16 QAM	1@1	24.13	17.88	0.0614
12	15	5	142700	713.5	DFT-s-OFDM QPSK	1@1	24.79	18.54	0.0714
12	15	5	142700	713.5	DFT-s-OFDM 16 QAM	1@1	24.17	17.92	0.0619
12	15	10	140800	704	DFT-s-OFDM QPSK	1@1	24.91	18.66	0.0735
12	15	10	140800	704	DFT-s-OFDM 16 QAM	1@1	24.33	18.08	0.0643
12	15	10	141500	707.5	DFT-s-OFDM QPSK	1@1	24.92	18.67	0.0736
12	15	10	141500	707.5	DFT-s-OFDM 16 QAM	1@1	24.2	17.95	0.0624
12	15	10	142200	711	DFT-s-OFDM QPSK	1@1	24.86	18.61	0.0726
12	15	10	142200	711	DFT-s-OFDM 16 QAM	1@1	24.24	17.99	0.0630
12	15	15	141300	706.5	DFT-s-OFDM PI/2 BPSK	36@18	24.71	18.46	0.0701
12	15	15	141300	706.5	DFT-s-OFDM PI/2 BPSK	1@1	24.79	18.54	0.0714
12	15	15	141300	706.5	DFT-s-OFDM PI/2 BPSK	1@77	24.5	18.25	0.0668
12	15	15	141300	706.5	DFT-s-OFDM QPSK	36@18	24.78	18.53	0.0713
12	15	15	141300	706.5	DFT-s-OFDM QPSK	1@1	24.95	18.7	0.0741
12	15	15	141300	706.5	DFT-s-OFDM QPSK	1@77	24.83	18.58	0.0721
12	15	15	141300	706.5	DFT-s-OFDM 16 QAM	36@18	24.35	18.1	0.0646
12	15	15	141300	706.5	DFT-s-OFDM 16 QAM	1@1	24.31	18.06	0.0640
12	15	15	141300	706.5	DFT-s-OFDM 16 QAM	1@77	24.14	17.89	0.0615
12	15	15	141300	706.5	DFT-s-OFDM 64 QAM	36@18	22.67	16.42	0.0439
12	15	15	141300	706.5	DFT-s-OFDM 64 QAM	1@1	22.55	16.3	0.0427
12	15	15	141300	706.5	DFT-s-OFDM 64 QAM	1@77	22.45	16.2	0.0417
12	15	15	141300	706.5	DFT-s-OFDM 256 QAM	36@18	20.94	14.69	0.0294
12	15	15	141300	706.5	DFT-s-OFDM 256 QAM	1@1	21.03	14.78	0.0301
12	15	15	141300	706.5	DFT-s-OFDM 256 QAM	1@77	20.9	14.65	0.0292
12	15	15	141300	706.5	CP-OFDM QPSK	39@19	23.82	17.57	0.0571
12	15	15	141300	706.5	CP-OFDM QPSK	1@1	24.26	18.01	0.0632
12	15	15	141300	706.5	CP-OFDM QPSK	1@77	24.04	17.79	0.0601
12	15	15	141500	707.5	DFT-s-OFDM PI/2 BPSK	36@18	24.7	18.45	0.0700
12	15	15	141500	707.5	DFT-s-OFDM PI/2 BPSK	1@1	24.73	18.48	0.0705
12	15	15	141500	707.5	DFT-s-OFDM PI/2 BPSK	1@77	24.46	18.21	0.0662
12	15	15	141500	707.5	DFT-s-OFDM QPSK	36@18	24.8	18.55	0.0716
12	15	15	141500	707.5	DFT-s-OFDM QPSK	1@1	24.94	18.69	0.0740
12	15	15	141500	707.5	DFT-s-OFDM QPSK	1@77	24.86	18.61	0.0726
12	15	15	141500	707.5	DFT-s-OFDM 16 QAM	36@18	24.34	18.09	0.0644

12	15	15	141500	707.5	DFT-s-OFDM 16 QAM	1@1	24.35	18.1	0.0646
12	15	15	141500	707.5	DFT-s-OFDM 16 QAM	1@77	24.08	17.83	0.0607
12	15	15	141500	707.5	DFT-s-OFDM 64 QAM	36@18	22.84	16.59	0.0456
12	15	15	141500	707.5	DFT-s-OFDM 64 QAM	1@1	22.6	16.35	0.0432
12	15	15	141500	707.5	DFT-s-OFDM 64 QAM	1@77	22.43	16.18	0.0415
12	15	15	141500	707.5	DFT-s-OFDM 256 QAM	36@18	20.89	14.64	0.0291
12	15	15	141500	707.5	DFT-s-OFDM 256 QAM	1@1	20.99	14.74	0.0298
12	15	15	141500	707.5	DFT-s-OFDM 256 QAM	1@77	20.81	14.56	0.0286
12	15	15	141500	707.5	CP-OFDM QPSK	39@19	23.81	17.56	0.0570
12	15	15	141500	707.5	CP-OFDM QPSK	1@1	24.18	17.93	0.0621
12	15	15	141500	707.5	CP-OFDM QPSK	1@77	24.1	17.85	0.0610
12	15	15	141700	708.5	DFT-s-OFDM PI/2 BPSK	36@18	24.76	18.51	0.0710
12	15	15	141700	708.5	DFT-s-OFDM PI/2 BPSK	1@1	24.71	18.46	0.0701
12	15	15	141700	708.5	DFT-s-OFDM PI/2 BPSK	1@77	24.4	18.15	0.0653
12	15	15	141700	708.5	DFT-s-OFDM QPSK	36@18	24.78	18.53	0.0713
12	15	15	141700	708.5	DFT-s-OFDM QPSK	1@1	24.8	18.55	0.0716
12	15	15	141700	708.5	DFT-s-OFDM QPSK	1@77	24.56	18.31	0.0678
12	15	15	141700	708.5	DFT-s-OFDM 16 QAM	36@18	24.32	18.07	0.0641
12	15	15	141700	708.5	DFT-s-OFDM 16 QAM	1@1	24.37	18.12	0.0649
12	15	15	141700	708.5	DFT-s-OFDM 16 QAM	1@77	24.21	17.96	0.0625
12	15	15	141700	708.5	DFT-s-OFDM 64 QAM	36@18	22.79	16.54	0.0451
12	15	15	141700	708.5	DFT-s-OFDM 64 QAM	1@1	22.9	16.65	0.0462
12	15	15	141700	708.5	DFT-s-OFDM 64 QAM	1@77	22.7	16.45	0.0442
12	15	15	141700	708.5	DFT-s-OFDM 256 QAM	36@18	20.84	14.59	0.0288
12	15	15	141700	708.5	DFT-s-OFDM 256 QAM	1@1	21.07	14.82	0.0303
12	15	15	141700	708.5	DFT-s-OFDM 256 QAM	1@77	20.88	14.63	0.0290
12	15	15	141700	708.5	CP-OFDM QPSK	39@19	23.79	17.54	0.0568
12	15	15	141700	708.5	CP-OFDM QPSK	1@1	24.31	18.06	0.0640
12	15	15	141700	708.5	CP-OFDM QPSK	1@77	24.05	17.8	0.0603

FR1 N12(ANT0) - SCS 30k

Transmitter Conducted Output Power And ERP, (G_T - L_C)=-4.1dB

NR Band	SCS	BandWidth	Arfcn	Freq(MHz)	Modulation	RB	Conducted Power(dBm)	ERP(dBm)	ERP(W)
12	30	10	140800	704	DFT-s-OFDM QPSK	1@1	24.91	18.66	0.0735
12	30	10	140800	704	DFT-s-OFDM 16 QAM	1@1	24.17	17.92	0.0619
12	30	10	141500	707.5	DFT-s-OFDM QPSK	1@1	24.88	18.63	0.0729
12	30	10	141500	707.5	DFT-s-OFDM 16 QAM	1@1	24.09	17.84	0.0608
12	30	10	142200	711	DFT-s-OFDM QPSK	1@1	24.87	18.62	0.0728
12	30	10	142200	711	DFT-s-OFDM 16 QAM	1@1	24.17	17.92	0.0619
12	30	15	141300	706.5	DFT-s-OFDM PI/2 BPSK	18@9	24.69	18.44	0.0698
12	30	15	141300	706.5	DFT-s-OFDM PI/2 BPSK	1@1	24.83	18.58	0.0721
12	30	15	141300	706.5	DFT-s-OFDM PI/2 BPSK	1@36	24.6	18.35	0.0684
12	30	15	141300	706.5	DFT-s-OFDM QPSK	18@9	24.67	18.42	0.0695
12	30	15	141300	706.5	DFT-s-OFDM QPSK	1@1	24.83	18.58	0.0721
12	30	15	141300	706.5	DFT-s-OFDM QPSK	1@36	24.64	18.39	0.0690
12	30	15	141300	706.5	DFT-s-OFDM 16 QAM	18@9	24.08	17.83	0.0607
12	30	15	141300	706.5	DFT-s-OFDM 16 QAM	1@1	24.14	17.89	0.0615
12	30	15	141300	706.5	DFT-s-OFDM 16 QAM	1@36	23.86	17.61	0.0577
12	30	15	141300	706.5	DFT-s-OFDM 64 QAM	18@9	22.67	16.42	0.0439
12	30	15	141300	706.5	DFT-s-OFDM 64 QAM	1@1	22.45	16.2	0.0417
12	30	15	141300	706.5	DFT-s-OFDM 64 QAM	1@36	22.31	16.06	0.0404
12	30	15	141300	706.5	DFT-s-OFDM 256 QAM	18@9	20.7	14.45	0.0279
12	30	15	141300	706.5	DFT-s-OFDM 256 QAM	1@1	20.9	14.65	0.0292
12	30	15	141300	706.5	DFT-s-OFDM 256 QAM	1@36	20.86	14.61	0.0289
12	30	15	141300	706.5	CP-OFDM QPSK	19@9	23.51	17.26	0.0532
12	30	15	141300	706.5	CP-OFDM QPSK	1@1	23.44	17.19	0.0524
12	30	15	141300	706.5	CP-OFDM QPSK	1@36	23.35	17.1	0.0513
12	30	15	141500	707.5	DFT-s-OFDM PI/2 BPSK	18@9	24.67	18.42	0.0695
12	30	15	141500	707.5	DFT-s-OFDM PI/2 BPSK	1@1	24.78	18.53	0.0713
12	30	15	141500	707.5	DFT-s-OFDM PI/2 BPSK	1@36	24.46	18.21	0.0662
12	30	15	141500	707.5	DFT-s-OFDM QPSK	18@9	24.69	18.44	0.0698
12	30	15	141500	707.5	DFT-s-OFDM QPSK	1@1	24.93	18.68	0.0738
12	30	15	141500	707.5	DFT-s-OFDM QPSK	1@36	24.65	18.4	0.0692
12	30	15	141500	707.5	DFT-s-OFDM 16 QAM	18@9	24.19	17.94	0.0622
12	30	15	141500	707.5	DFT-s-OFDM 16 QAM	1@1	24.11	17.86	0.0611
12	30	15	141500	707.5	DFT-s-OFDM 16 QAM	1@36	23.96	17.71	0.0590
12	30	15	141500	707.5	DFT-s-OFDM 64 QAM	18@9	22.64	16.39	0.0436
12	30	15	141500	707.5	DFT-s-OFDM 64 QAM	1@1	22.56	16.31	0.0428
12	30	15	141500	707.5	DFT-s-OFDM 64 QAM	1@36	22.4	16.15	0.0412
12	30	15	141500	707.5	DFT-s-OFDM 256 QAM	18@9	20.68	14.43	0.0277

12	30	15	141500	707.5	DFT-s-OFDM 256 QAM	1@1	20.95	14.7	0.0295
12	30	15	141500	707.5	DFT-s-OFDM 256 QAM	1@36	20.79	14.54	0.0284
12	30	15	141500	707.5	CP-OFDM QPSK	19@9	23.54	17.29	0.0536
12	30	15	141500	707.5	CP-OFDM QPSK	1@1	23.48	17.23	0.0528
12	30	15	141500	707.5	CP-OFDM QPSK	1@36	23.26	17.01	0.0502
12	30	15	141700	708.5	DFT-s-OFDM PI/2 BPSK	18@9	24.66	18.41	0.0693
12	30	15	141700	708.5	DFT-s-OFDM PI/2 BPSK	1@1	24.7	18.45	0.0700
12	30	15	141700	708.5	DFT-s-OFDM PI/2 BPSK	1@36	24.45	18.2	0.0661
12	30	15	141700	708.5	DFT-s-OFDM QPSK	18@9	24.63	18.38	0.0689
12	30	15	141700	708.5	DFT-s-OFDM QPSK	1@1	24.9	18.65	0.0733
12	30	15	141700	708.5	DFT-s-OFDM QPSK	1@36	24.67	18.42	0.0695
12	30	15	141700	708.5	DFT-s-OFDM 16 QAM	18@9	24.13	17.88	0.0614
12	30	15	141700	708.5	DFT-s-OFDM 16 QAM	1@1	23.99	17.74	0.0594
12	30	15	141700	708.5	DFT-s-OFDM 16 QAM	1@36	23.88	17.63	0.0579
12	30	15	141700	708.5	DFT-s-OFDM 64 QAM	18@9	22.72	16.47	0.0444
12	30	15	141700	708.5	DFT-s-OFDM 64 QAM	1@1	22.65	16.4	0.0437
12	30	15	141700	708.5	DFT-s-OFDM 64 QAM	1@36	22.58	16.33	0.0430
12	30	15	141700	708.5	DFT-s-OFDM 256 QAM	18@9	20.6	14.35	0.0272
12	30	15	141700	708.5	DFT-s-OFDM 256 QAM	1@1	20.96	14.71	0.0296
12	30	15	141700	708.5	DFT-s-OFDM 256 QAM	1@36	20.78	14.53	0.0284
12	30	15	141700	708.5	CP-OFDM QPSK	19@9	23.54	17.29	0.0536
12	30	15	141700	708.5	CP-OFDM QPSK	1@1	23.44	17.19	0.0524
12	30	15	141700	708.5	CP-OFDM QPSK	1@36	23.28	17.03	0.0505

FR1 N12(ANT0) - SCS 15k

Frequency Stability

NR Band	SCS (kHz)	Bandwidth (MHz)	Arfcn	Freq (MHz)	Modulation	RB	Deviation (ppm)	Verdict	Environment
12	15	10	141500	707.5	DFT-s-OFDM QPSK	50@0	0.0064	PASS	NV
12	15	10	141500	707.5	DFT-s-OFDM QPSK	50@0	0.0060	PASS	LV
12	15	10	141500	707.5	DFT-s-OFDM QPSK	50@0	0.0046	PASS	HV
12	15	10	141500	707.5	DFT-s-OFDM QPSK	50@0	0.0050	PASS	-30°C
12	15	10	141500	707.5	DFT-s-OFDM QPSK	50@0	0.0037	PASS	-20°C
12	15	10	141500	707.5	DFT-s-OFDM QPSK	50@0	0.0022	PASS	-10°C
12	15	10	141500	707.5	DFT-s-OFDM QPSK	50@0	0.0045	PASS	0°C
12	15	10	141500	707.5	DFT-s-OFDM QPSK	50@0	0.0057	PASS	10°C
12	15	10	141500	707.5	DFT-s-OFDM QPSK	50@0	0.0064	PASS	20°C
12	15	10	141500	707.5	DFT-s-OFDM QPSK	50@0	0.0040	PASS	30°C
12	15	10	141500	707.5	DFT-s-OFDM QPSK	50@0	0.0027	PASS	40°C
12	15	10	141500	707.5	DFT-s-OFDM QPSK	50@0	0.0068	PASS	50°C

Peak to Average Ratio

NR Band	SCS (kHz)	Bandwidth (MHz)	Arfcn	Freq (MHz)	Modulation	RB	Result (dB)	Limit (dB)	Verdict
12	15	10	141500	707.5	DFT-s-OFDM PI/2 BPSK	50@0	3.7	13	PASS
12	15	10	141500	707.5	DFT-s-OFDM QPSK	50@0	5.16	13	PASS

N12(10M)_DFT-s-OFDM_PI_2-BPSK_Outer_Full_Mid_CH



N12(10M)_DFT-s-OFDM_QPSK_Outer_Full_Mid_CH



Occupied Bandwidth

NR Band	SCS (kHz)	Bandwidth (MHz)	Arfcn	Freq (MHz)	Modulation	RB	OBW (MHz)	26dB BW (MHz)
12	15	5	141500	707.5	CP-OFDM QPSK	25@0	4.4766	4.879
12	15	5	141500	707.5	CP-OFDM 16 QAM	25@0	4.4748	4.867
12	15	5	141500	707.5	CP-OFDM 64 QAM	25@0	4.4808	4.81
12	15	5	141500	707.5	CP-OFDM 256 QAM	25@0	4.4629	4.848
12	15	10	141500	707.5	CP-OFDM QPSK	52@0	9.2721	9.694
12	15	10	141500	707.5	CP-OFDM 16 QAM	52@0	9.2914	9.762
12	15	10	141500	707.5	CP-OFDM 64 QAM	52@0	9.2553	9.704
12	15	10	141500	707.5	CP-OFDM 256 QAM	52@0	9.2443	9.647
12	15	15	141500	707.5	CP-OFDM QPSK	79@0	14.115	14.65
12	15	15	141500	707.5	CP-OFDM 16 QAM	79@0	14.159	14.68
12	15	15	141500	707.5	CP-OFDM 64 QAM	79@0	14.021	14.64
12	15	15	141500	707.5	CP-OFDM 256 QAM	79@0	14.087	14.72

N12(5M)_CP-OFDM_QPSK_Outer_Full_Mid_CH

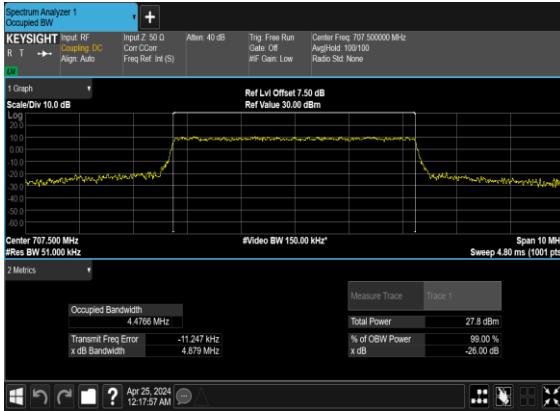

N12(5M)_CP-OFDM_16QAM_Outer_Full_Mid_CH

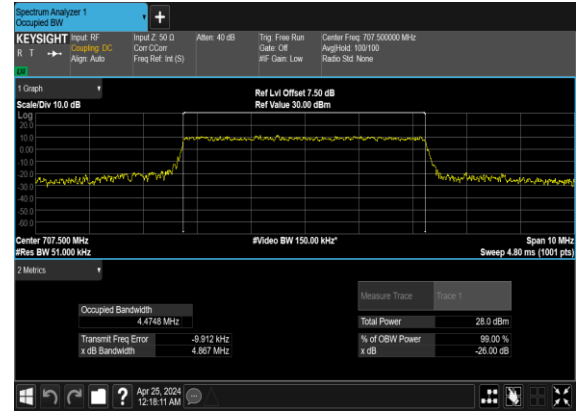

N12(5M)_CP-OFDM_64QAM_Outer_Full_Mid_CH

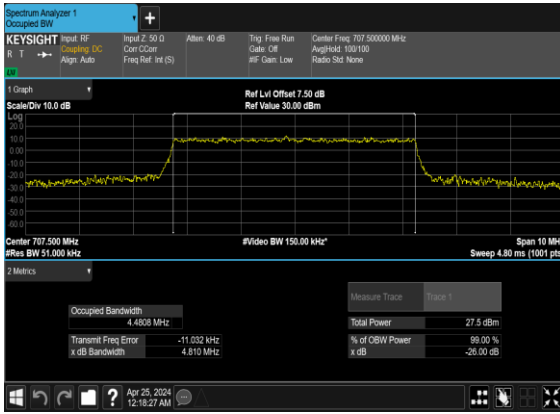

N12(5M)_CP-OFDM_256QAM_Outer_Full_Mid_CH

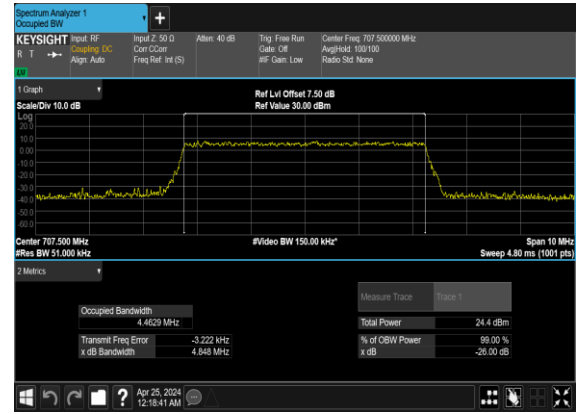

N12(10M)_CP-OFDM_QPSK_Outer_Full_Mid_CH

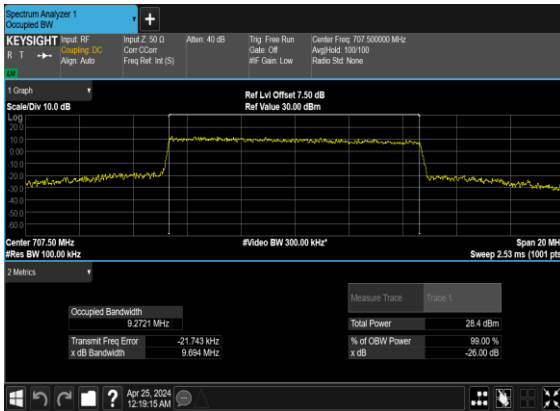

N12(10M)_CP-OFDM_16QAM_Outer_Full_Mid_CH

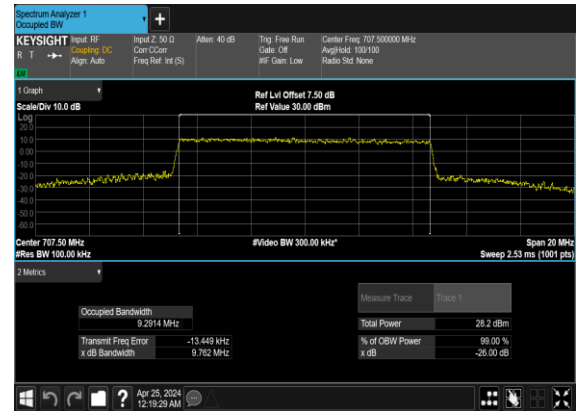

N12(10M)_CP-OFDM_64 QAM_Outer_Full_Mid_CH

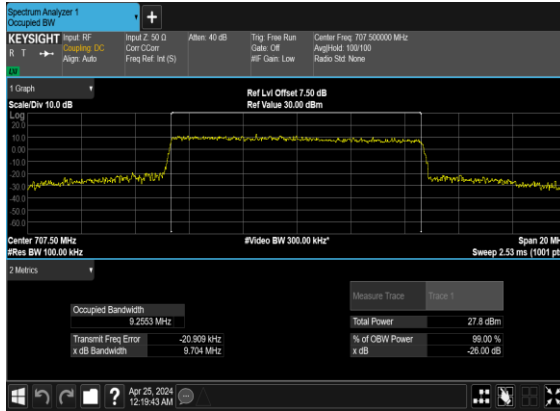

N12(10M)_CP-OFDM_256 QAM_Outer_Full_Mid_CH

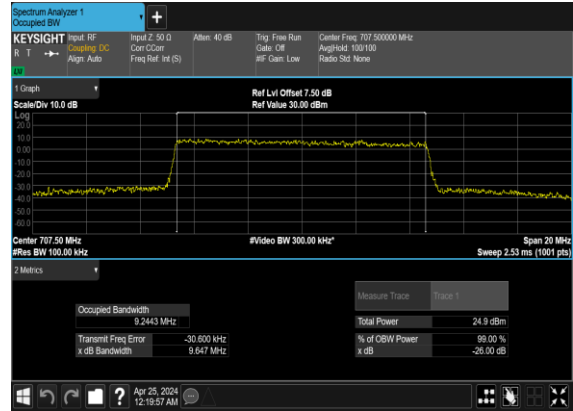

N12(15M)_CP- OFDM_QPSK_Outer_Full_Mid_CH

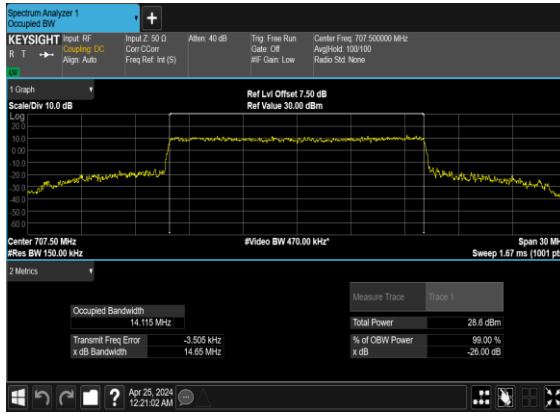

N12(15M)_CP-OFDM_16 QAM_Outer_Full_Mid_CH

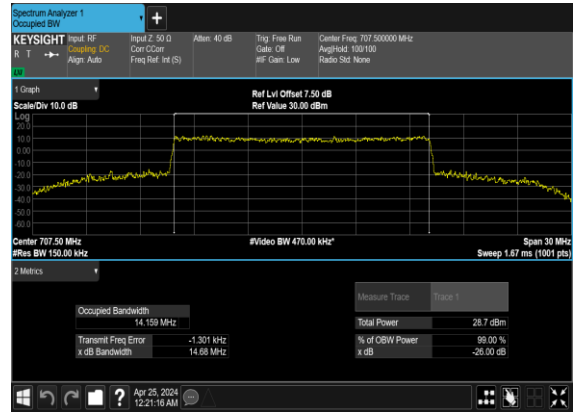

N12(15M)_CP-OFDM_64 QAM_Outer_Full_Mid_CH

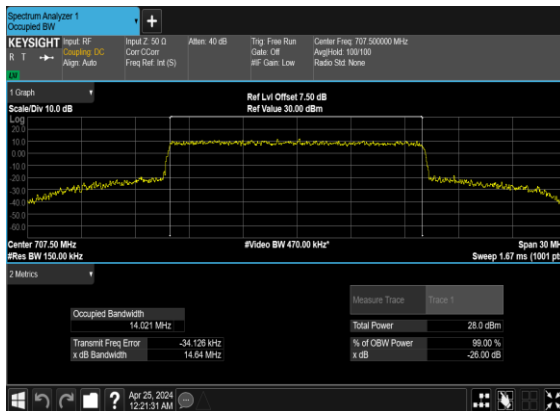

N12(15M)_CP-OFDM_256 QAM_Outer_Full_Mid_CH

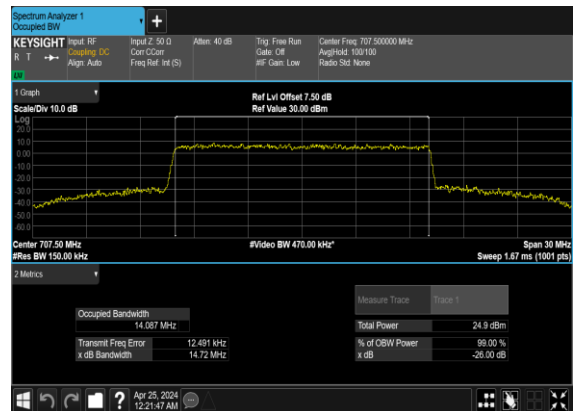

Conducted Spurious Emissions

NR Band	SCS (kHz)	Bandwidth (MHz)	Arfcn	Freq (MHz)	Modulation	RB	Result	Verdict
12	15	5	140300	701.5	DFT-s-OFDM BPSK	1@0	see graph	---
12	15	5	140300	701.5	DFT-s-OFDM BPSK	1@0	see graph	PASS
12	15	5	140300	701.5	DFT-s-OFDM QPSK	1@0	see graph	---
12	15	5	140300	701.5	DFT-s-OFDM QPSK	1@0	see graph	PASS
12	15	5	141500	707.5	DFT-s-OFDM BPSK	1@0	see graph	---
12	15	5	141500	707.5	DFT-s-OFDM BPSK	1@0	see graph	PASS
12	15	5	141500	707.5	DFT-s-OFDM QPSK	1@0	see graph	---
12	15	5	141500	707.5	DFT-s-OFDM QPSK	1@0	see graph	PASS
12	15	5	142700	713.5	DFT-s-OFDM BPSK	1@0	see graph	---
12	15	5	142700	713.5	DFT-s-OFDM BPSK	1@0	see graph	PASS
12	15	5	142700	713.5	DFT-s-OFDM QPSK	1@0	see graph	---
12	15	5	142700	713.5	DFT-s-OFDM QPSK	1@0	see graph	PASS
12	15	10	140800	704.0	DFT-s-OFDM BPSK	1@0	see graph	---
12	15	10	140800	704.0	DFT-s-OFDM BPSK	1@0	see graph	PASS
12	15	10	140800	704.0	DFT-s-OFDM QPSK	1@0	see graph	---
12	15	10	140800	704.0	DFT-s-OFDM QPSK	1@0	see graph	PASS
12	15	10	141500	707.5	DFT-s-OFDM BPSK	1@0	see graph	---
12	15	10	141500	707.5	DFT-s-OFDM BPSK	1@0	see graph	PASS
12	15	10	141500	707.5	DFT-s-OFDM QPSK	1@0	see graph	---
12	15	10	141500	707.5	DFT-s-OFDM QPSK	1@0	see graph	PASS
12	15	10	142200	711.0	DFT-s-OFDM BPSK	1@0	see graph	---
12	15	10	142200	711.0	DFT-s-OFDM BPSK	1@0	see graph	PASS

12	15	10	142200	711.0	DFT-s-OFDM QPSK	1@0	see graph	---
12	15	10	142200	711.0	DFT-s-OFDM QPSK	1@0	see graph	PASS
12	15	15	141300	706.5	DFT-s-OFDM BPSK	1@0	see graph	---
12	15	15	141300	706.5	DFT-s-OFDM BPSK	1@0	see graph	PASS
12	15	15	141300	706.5	DFT-s-OFDM QPSK	1@0	see graph	---
12	15	15	141300	706.5	DFT-s-OFDM QPSK	1@0	see graph	PASS
12	15	15	141500	707.5	DFT-s-OFDM BPSK	1@0	see graph	---
12	15	15	141500	707.5	DFT-s-OFDM BPSK	1@0	see graph	PASS
12	15	15	141500	707.5	DFT-s-OFDM QPSK	1@0	see graph	---
12	15	15	141500	707.5	DFT-s-OFDM QPSK	1@0	see graph	PASS
12	15	15	141700	708.5	DFT-s-OFDM BPSK	1@0	see graph	---
12	15	15	141700	708.5	DFT-s-OFDM BPSK	1@0	see graph	PASS
12	15	15	141700	708.5	DFT-s-OFDM QPSK	1@0	see graph	---
12	15	15	141700	708.5	DFT-s-OFDM QPSK	1@0	see graph	PASS

N12(5M)_DFT-s-OFDM_BPSK_Edge_1RB_Left_Low_CH

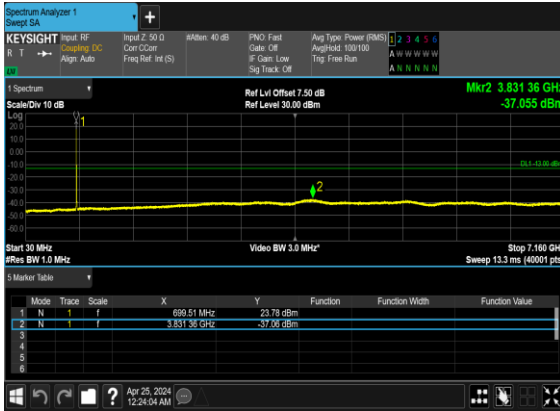

N12(5M)_DFT-s-OFDM_QPSK_Edge_1RB_Left_Low_CH

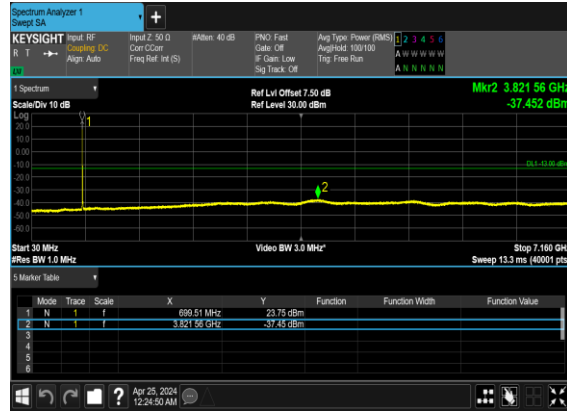

N12(5M)_DFT-s-OFDM_BPSK_Edge_1RB_Left_Mid_CH

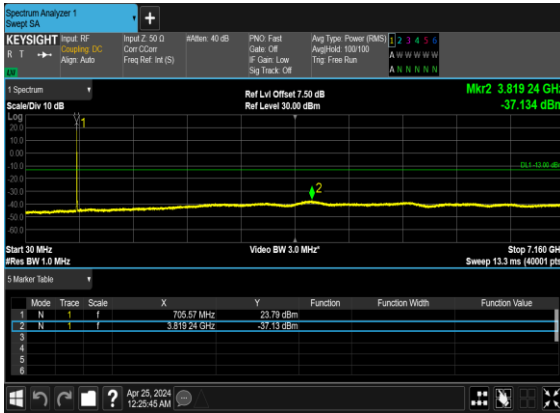

N12(5M)_DFT-s-OFDM_QPSK_Edge_1RB_Left_Mid_CH

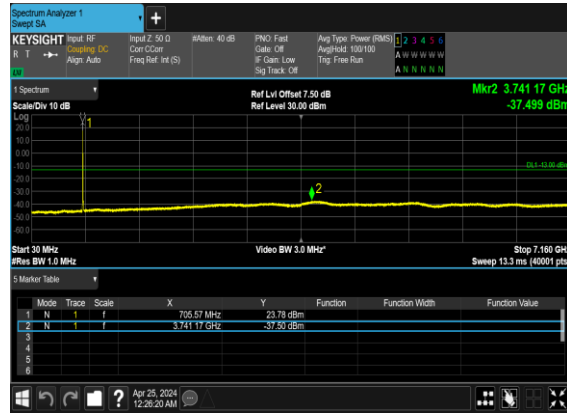

N12(5M)_DFT-s-OFDM_BPSK_Edge_1RB_Left_High_CH



N12(5M)_DFT-s-OFDM_QPSK_Edge_1RB_Left_High_CH

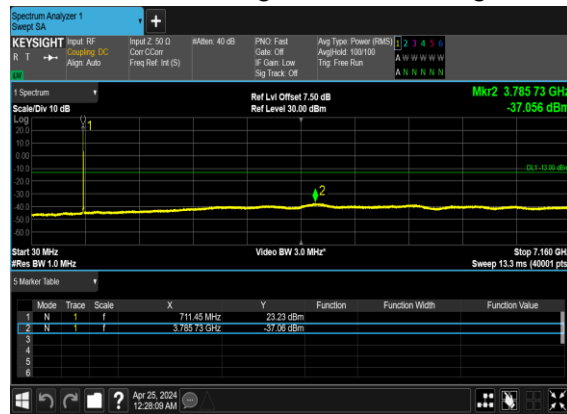

N12(10M)_DFT-s-OFDM_BPSK_Edge_1RB_Left_Low_CH

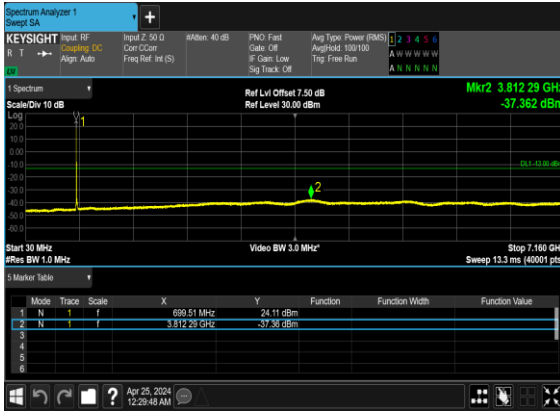

N12(10M)_DFT-s-OFDM_QPSK_Edge_1RB_Left_Low_CH

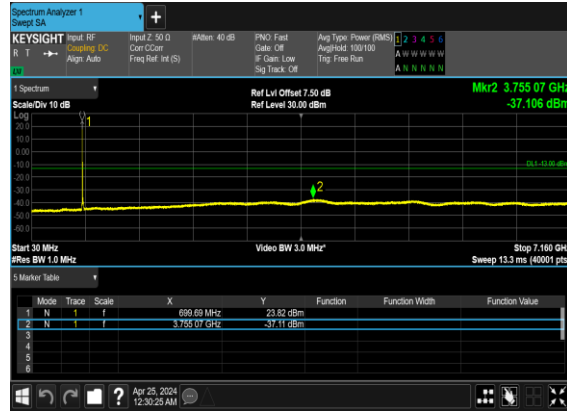

N12(10M)_DFT-s-OFDM_BPSK_Edge_1RB_Left_Mid_CH

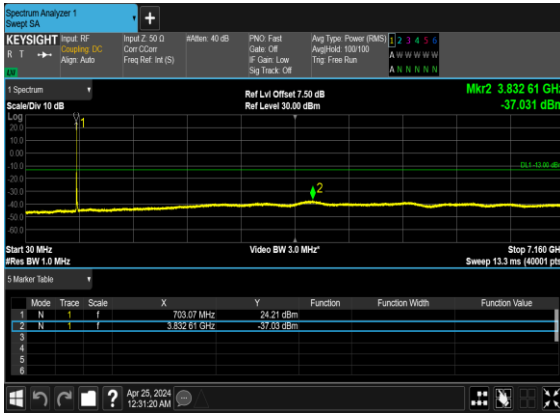

N12(10M)_DFT-s-OFDM_QPSK_Edge_1RB_Left_Mid_CH

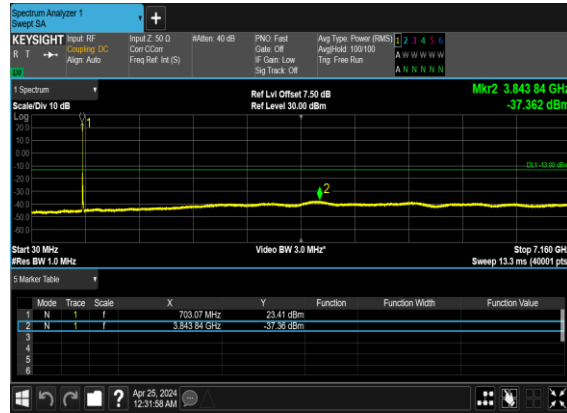

N12(10M)_DFT-s-OFDM_BPSK_Edge_1RB_Left_High_CH



N12(10M)_DFT-s-OFDM_QPSK_Edge_1RB_Left_High_CH

