



Test Report No.: W7L-P24030005RF03



FCC TEST REPORT

(Part 15, Subpart E)

Applicant:	Xiaomi Communications Co., Ltd.
Address:	#019, 9th Floor, Building 6, 33 Xi'erqi Middle Road, Haidian District, Beijing, China, 100085

Manufacturer or Supplier:	Xiaomi Communications Co., Ltd.
Address:	#019, 9th Floor, Building 6, 33 Xi'erqi Middle Road, Haidian District, Beijing, China, 100085
Product:	Tablet Computer
Brand Name:	Redmi
Model Name:	2405CRPFDL
FCC ID:	2AFZZPFDL
Date of tests:	Mar. 12, 2024 ~ Apr. 01, 2024

The tests have been carried out according to the requirements of the following standard:

FCC Part 15, Subpart E, Section 15.407

CONCLUSION: The submitted sample was found to COMPLY with the test requirement

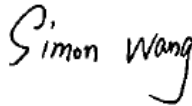
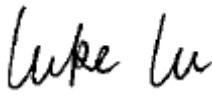
Prepared by Simon Wang Engineer / Mobile Department	Approved by Luke Lu Manager / Mobile Department
 Date: Apr. 01, 2024	 Date: Apr. 01, 2024

This report is governed by, and incorporates by reference, the Conditions of Testing as posted at the date of issuance of this report at <http://www.bureauveritas.com/home/about-us/our-business/cps/about-us/terms-conditions/> and is intended for your exclusive use. Any copying or replication of this report to or for any other person or entity, or use of our name or trademark, is permitted only with our prior written permission. This report sets forth our findings solely with respect to the test samples identified herein. The results set forth in this report are not indicative or representative of the quality or characteristics of the lot from which a test sample was taken or any similar or identical product unless specifically and expressly noted. Our report includes all of the tests requested by you and the results thereof based upon the information that you provided to us. Measurement uncertainty is only provided upon request for accredited tests. Statements of conformity are based on simple acceptance criteria without taking measurement uncertainty into account, unless otherwise requested in writing. You have 60 days from date of issuance of this report to notify us of any material error or omission caused by our negligence or if you require measurement uncertainty; provided, however, that such notice shall be in writing and shall specifically address the issue you wish to raise. A failure to raise such issue within the prescribed time shall constitute your unqualified acceptance of the completeness of this report, the tests conducted and the correctness of the report contents.



TABLE OF CONTENTS

RELEASE CONTROL RECORD	4
1 SUMMARY OF TEST RESULTS	5
1.1 MEASUREMENT UNCERTAINTY	6
2 GENERAL INFORMATION.....	7
2.1 GENERAL DESCRIPTION OF EUT	7
2.2 DESCRIPTION OF TEST MODES	10
2.2.1 TEST MODE APPLICABILITY AND TESTED CHANNEL DETAIL.....	13
2.3 DUTY CYCLE OF TEST SIGNAL	19
2.4 DESCRIPTION OF SUPPORT UNITS	20
2.4.1 CONFIGURATION OF SYSTEM UNDER TEST	21
2.5 GENERAL DESCRIPTION OF APPLIED STANDARDS	22
3 TEST TYPES AND RESULTS.....	23
3.1 RADIATED EMISSION AND BANDEDGE MEASUREMENT.....	23
3.1.1 LIMITS OF RADIATED EMISSION AND BANDEDGE MEASUREMENT.....	23
3.1.2 LIMITS OF UNWANTED EMISSION.....	23
3.1.3 TEST INSTRUMENTS.....	24
3.1.4 TEST PROCEDURES	25
3.1.5 DEVIATION FROM TEST STANDARD	25
3.1.6 TEST SETUP	26
3.1.7 EUT OPERATING CONDITION	27
3.1.8 TEST RESULTS	28
3.2 CONDUCTED EMISSION MEASUREMENT	202
3.2.1 LIMITS OF CONDUCTED EMISSION MEASUREMENT	202
3.2.2 TEST INSTRUMENTS.....	202
3.2.3 TEST PROCEDURES	202
3.2.4 DEVIATION FROM TEST STANDARD	203
3.2.5 TEST SETUP	203
3.2.6 EUT OPERATING CONDITIONS	203
3.2.7 TEST RESULTS	204
3.3 MAXIMUM CONDUCTED OUTPUT POWER MEASUREMENT	206
3.3.1 LIMITS OF MAXIMUM CONDUCTED OUTPUT POWER MEASUREMENT	206
3.3.2 TEST SETUP	207
3.3.3 TEST INSTRUMENTS.....	207



3.3.4	TEST PROCEDURE	208
3.3.5	DEVIATION FROM TEST STANDARD	210
3.3.6	EUT OPERATING CONDITIONS	210
3.3.7	TEST RESULTS	211
3.4	MAXIMUM POWER SPECTRAL DENSITY MEASUREMENT	212
3.4.1	LIMITS OF MAXIMUM POWER SPECTRAL DENSITY MEASUREMENT	212
3.4.2	TEST SETUP	212
3.4.3	TEST INSTRUMENTS	212
3.4.4	TEST PROCEDURES	213
3.4.5	DEVIATION FROM TEST STANDARD	213
3.4.6	EUT OPERATING CONDITIONS	213
3.4.7	TEST RESULTS	214
3.5	AUTOMATICALLY DISCONTINUE TRANSMISSION	215
3.5.1	LIMIT OF AUTOMATICALLY DISCONTINUE TRANSMISSION	215
3.5.2	TEST INSTRUMENTS	215
3.5.3	TEST RESULT	215
3.6	ANTENNA REQUIREMENTS	216
3.6.1	STANDARD APPLICABLE	216
3.6.2	ANTENNA CONNECTED CONSTRUCTION	216
3.6.3	ANTENNA GAIN	216
4	PHOTOGRAPHS OF THE TEST CONFIGURATION	217
5	MODIFICATIONS RECORDERS FOR ENGINEERING CHANGES TO THE EUT BY THE LAB218	
6	APPENDIX A: RLAN	219
7	APPENDIX B: OFDMA	550



BUREAU
VERITAS

Test Report No.: W7L-P24030005RF03

RELEASE CONTROL RECORD

ISSUE NO.	REASON FOR CHANGE	DATE ISSUED
W7L-P24030005RF03	Original release	Apr. 01, 2024



1 SUMMARY OF TEST RESULTS

The EUT has been tested according to the following specifications:

APPLIED STANDARD: FCC PART 15, SUBPART E		
STANDARD SECTION	TEST TYPE AND LIMIT	RESULT
15.407(b)(9)	AC Power Conducted Emission	Compliance
15.407(b) (1/2/3/4/5)	Radiated Emission & Band Edge Measurement	Compliance
15.407(a/1/2/3)	Maximum conducted output Power	Compliance
15.407(a/1/2/3)	Peak Power Spectral Density	Compliance
15.407(a)(2)(12)	26 dB Bandwidth	Compliance
15.407(e)	6 dB Bandwidth	Compliance
15.203	Antenna Requirement	Compliance

NOTE:

1. Except the data of RSE and Band Edge Measurement, other data please refer to the appendix A and Appendix B.
2. (1) 242T(RU fully) mode and 802.11ax 20 are the same ;
802.11 ax HE20 26T,52T,106T modes tested

(2) 802.11 ax HE40 484T and 802.11ax 40 are the same
26T,52T,106T,and 242T modes are covered by the 802.11 ax HE20 modes

(3) 802.11 ax HE80 996T and 802.11ax 80 are the same
26T,52T,106T,and 242T modes are covered by the 802.11 ax HE20 and 802.11 ax HE40 modes

(4) 802.11 ax HE160 2*996T and 802.11ax 160 are the same
26T,52T,106T,and 242T modes are covered by the 802.11 ax HE20 and 802.11 ax HE40 , 802.11 ax HE80 modes
3. Only the worse data were report

1.1 MEASUREMENT UNCERTAINTY

Where relevant, the following measurement uncertainty levels have been estimated for tests performed on the EUT as specified in CISPR 16-4-2:

MEASUREMENT	UNCERTAINTY
AC Power Conducted emissions	±2.70dB
Radiated emissions (9KHz~30MHz)	±2.68dB
Radiated emissions (30MHz~1GHz)	±4.98dB
Radiated emissions (1GHz ~6GHz)	±4.70dB
Radiated emissions (6GHz ~18GHz)	±4.60dB
Radiated emissions (18GHz ~40GHz)	±4.12dB
Conducted emissions	±4.01dB
Occupied Channel Bandwidth	±43.58KHz
Conducted Output power	±2.06dB
Power Spectral Density	±0.85 dB

This uncertainty represents an expanded uncertainty expressed at approximately the 95% confidence level using a coverage factor of $k = 2$.



2 GENERAL INFORMATION

2.1 GENERAL DESCRIPTION OF EUT

PRODUCT	Tablet Computer
BRAND NAME	Redmi
MODEL NAME	2405CRPFDL
NOMINAL VOLTAGE	5.0Vdc(adapter or host equipment) 3.84Vdc (Li-ion, battery)
MODULATION	OFDM, OFDMA
TRANSFER RATE	802.11a: 54.0/ 48.0/ 36.0/ 24.0/ 18.0/ 12.0/ 9.0/ 6.0Mbps 802.11n: up to 300.0Mbps 802.11ac: up to 866.6Mbps 802.11ax: up to 1201Mbps
OPERATING FREQUENCY	5180 ~ 5240MHz, 5260 ~ 5320MHz, 5500 ~ 5700MHz, 5745 ~ 5825MHz
NUMBER OF CHANNEL	<p>5180 ~ 5240MHz:</p> <ul style="list-style-type: none"> 4 for 802.11a, 802.11n/ac/ax (20MHz)/ 802.11ax(20M RU 26/52/106/242) 2 for 802.11n/ac/ax (40MHz)/ 802.11ax(40M RU 484) 1 for 802.11ac/ax (80MHz)/ 802.11ax(80MRU996) 1 for 802.11ax(160MRU FULL) <p>5260 ~ 5320MHz:</p> <ul style="list-style-type: none"> 4 for 802.11a, 802.11n/ac/ax (20MHz)/ 802.11ax(20M RU 26/52/106/242) 2 for 802.11n/ac/ax (40MHz)/ 802.11ax(40M RU 484) 1 for 802.11ac/ax (80MHz)/ 802.11ax(80M RU 996) <p>5500 ~ 5700MHz:</p> <ul style="list-style-type: none"> 12 for 802.11a, 802.11n/ac/ax (20MHz)/ 802.11ax(20M RU 26/52/106/242) 6 for 802.11n/ac/ax (40MHz)/ 802.11ax(40M RU 484) 3 for 802.11ac/ax (80MHz)/ 802.11ax(80M RU 996) 1 for 802.11ax(160M RU FULL) <p>5745 ~ 5825MHz:</p> <ul style="list-style-type: none"> 5 for 802.11a, 802.11n/ac/ax (20MHz)/ 802.11ax(20M RU 26/52/106/242) 2 for 802.11n/ac/ax (40MHz)/ 802.11ax(40M RU 484) 1 for 802.11ac/ax (80MHz)/ 802.11ax(80MRU 996)



MAX. OUTPUT POWER	106.66 mW for 5180 ~ 5240MHz 108.89 mW for 5260 ~ 5320MHz 101.39 mW for 5500 ~ 5700MHz 101.16 mW for 5745 ~ 5825MHz
ANTENNA TYPE	PIFA Antenna
ANTENNA GAIN	ANT 1: 0.3dBi for 5180 ~ 5240MHz 0.5dBi for 5260 ~ 5320MHz 0.8dBi for 5500 ~ 5700MHz 0.5dBi for 5745 ~ 5825MHz ANT 2: 0.9dBi for 5180 ~ 5240MHz 0.8dBi for 5260 ~ 5320MHz 0.5dBi for 5500 ~ 5700MHz 0.5dBi for 5745 ~ 5825MHz
HW VERSION	13510N83
SW VERSION	Xiaomi HyperOS 1.0
SN CODE	GB409L000012/GB409L000032/GB409L000023
I/O PORTS	Refer to user's manual
CABLE SUPPLIED	USB cable1: non-shielded cable, with w/o ferrite core, 1.0 meter USB cable2: non-shielded cable, with w/o ferrite core, 1.0 meter USB cable3: non-shielded cable, with w/o ferrite core, 1.0 meter USB cable4: non-shielded cable, with w/o ferrite core, 1.0 meter

NOTE:

1. For a more detailed features description, please refer to the manufacturer's specifications or the user's manual.
2. The EUT incorporates a MIMO function. Physically, the EUT provides two completed transmitter and two receiver.

MODULATION MODE	TX FUNCTION
802.11a	2TX/2RX
802.11n/802.11ac/ax (20MHz)	2TX/2RX
802.11n/802.11ac/ax (40MHz)	2TX/2RX
802.11ac/ax (80MHz)	2TX/2RX
802.11ax (20MHz RU 26/52/106/242)	2TX/2RX
802.11ax (40MHz RU 484)	2TX/2RX
802.11ax (80MHz RU 996)	2TX/2RX



**BUREAU
VERITAS**

Test Report No.: W7L-P24030005RF03

802.11ax(160M RU full)

2TX/2RX

3. For the test results, the EUT had been tested with all conditions. But only the worst case was shown in test report.
4. Antenna gain and EUT conducted cable loss are provided by the customer, and the laboratory will record the results based on these items that involve these two parameters.



2.2 DESCRIPTION OF TEST MODES

FOR 5180 ~ 5240MHz

4 channels are provided for 802.11a, 802.11n, 802.11ac/ax (20MHz)/ 802.11ax (20MHz RU 26/52/106/242):

CHANNEL	FREQUENCY	CHANNEL	FREQUENCY
36	5180 MHz	44	5220 MHz
40	5200 MHz	48	5240 MHz

2 channels are provided for 802.11n, 802.11ac/ax (40MHz)/ 802.11ax (40MHz RU 484):

CHANNEL	FREQUENCY	CHANNEL	FREQUENCY
38	5190 MHz	46	5230 MHz

1 channel is provided for 802.11ac/ax (80MHz)/ 802.11ax (80MHz RU 996):

CHANNEL	FREQUENCY	CHANNEL	FREQUENCY
42	5210 MHz		

1 channels are provided for 802.11ac (160MHz), 802.11ax160 (RU full):

CHANNEL	FREQUENCY	CHANNEL	FREQUENCY
50	5250MHz		

FOR 5260 ~ 5320MHz

4 channels are provided for 802.11a, 802.11n, 802.11ac/ax (20MHz)/ 802.11ax (20MHz RU 26/52/106/242):

CHANNEL	FREQUENCY	CHANNEL	FREQUENCY
52	5260 MHz	60	5300 MHz
56	5280 MHz	64	5320 MHz

2 channels are provided for 802.11n, 802.11ac/ax (40MHz)/ 802.11ax (40MHz RU 484):

CHANNEL	FREQUENCY	CHANNEL	FREQUENCY
54	5270 MHz	62	5310 MHz

1 channel is provided for 802.11ac/ax (80MHz)/ 802.11ax (80MHz RU 996):

CHANNEL	FREQUENCY	CHANNEL	FREQUENCY
58	5290 MHz		



FOR 5500 ~ 5700MHz

12 channels are provided for 802.11a, 802.11n, 802.11ac/ax (20MHz)/ 802.11ax (20MHz RU 26/52/106/242):

CHANNEL	FREQUENCY	CHANNEL	FREQUENCY
100	5500 MHz	124	5620MHz
104	5520 MHz	128	5640MHz
108	5540 MHz	132	5660 MHz
112	5560 MHz	136	5680 MHz
116	5580 MHz	140	5700 MHz
120	5600 MHz		

6 channels are provided for 802.11n, 802.11ac/ax (40MHz)/ 802.11ax (40MHz RU 484):

CHANNEL	FREQUENCY	CHANNEL	FREQUENCY
102	5510 MHz	126	5630MHz
110	5550 MHz	134	5670 MHz
118	5590 MHz		

3 channel is provided for 802.11ac/ax (80MHz)/ 802.11ax (80MHz RU 996):

CHANNEL	FREQUENCY	CHANNEL	FREQUENCY
106	5530 MHz	122	5610 MHz

1 channels are provided for 802.11ac (160MHz), 802.11ax160 (RU full):

CHANNEL	FREQUENCY	CHANNEL	FREQUENCY
114	5570MHz		



FOR 5745 ~ 5825MHz

5 channels are provided for 802.11a, 802.11n, 802.11ac/ax (20MHz)/ 802.11ax (20MHz RU 26/52/106/242):

CHANNEL	FREQUENCY	CHANNEL	FREQUENCY
149	5745 MHz	161	5805 MHz
153	5765 MHz	165	5825 MHz
157	5785 MHz		

2 channels are provided for 802.11n, 802.11ac/ax (40MHz)/ 802.11ax (40MHz RU 484):

CHANNEL	FREQUENCY	CHANNEL	FREQUENCY
142	5710 MHz	159	5795 MHz
151	5755 MHz		

1 channel is provided for 802.11ac/ax (80MHz)/ 802.11ax (80MHz RU 996):

CHANNEL	FREQUENCY
155	5775 MHz



2.2.1 TEST MODE APPLICABILITY AND TESTED CHANNEL DETAIL

EUT CONFIGURE MODE	APPLICABLE TO				DESCRIPTION
	RE≥1G	RE<1G	PLC	APCM	
A	√	√	√	-	Powered by Adapter with wifi(5G) link
B	-	-	-	√	Powered by Battery with wifi(5G) link
C	-	-	-	-	Powered by USB with wifi(5G) link

Where **RE≥1G**: Radiated Emission above 1GHz **RE<1G**: Radiated Emission below 1GHz
PLC: Power Line Conducted Emission **APCM**: Antenna Port Conducted Measurement

NOTE:
The EUT had been pre-tested on the positioned of each 3 axis. The worst case was found when positioned on **X-plane**.
NOTE: “-” means no effect

RADIATED EMISSION TEST (BELOW 1GHz):

- Pre-Scan has been conducted to determine the worst-case mode from all possible combinations between available modulations, data rates and antenna ports (if EUT with antenna diversity architecture).
- The following channel(s) was (were) selected for the final test as listed below.

EUT CONFIGURE MODE	MODE	FREQ. BAND (MHz)	AVAILABLE CHANNEL	TESTED CHANNEL	MODULATION	DATA RATE (Mbps)
A	802.11ax (40MHz)	5260-5320	54 to 62	62	OFDM	MCS0



RADIATED EMISSION TEST (ABOVE 1GHz):

- Pre-Scan has been conducted to determine the worst-case mode from all possible combinations between available modulations, data rates and antenna ports (if EUT with antenna diversity architecture).
- The following channel(s) was (were) selected for the final test as listed below.

EUT CONFIGURE MODE	MODE	FREQ. BAND (MHz)	AVAILABLE CHANNEL	TESTED CHANNEL	MODULATION	DATA RATE (Mbps)
A	802.11a	5180-5240	36 to 48	36, 40, 48	OFDM	6.0
A	802.11n/ac/ax (20MHz)/ 802.11ax (20MHz RU 26/52/106/242)		36 to 48	36, 40, 48	OFDM, OFDMA	MCS0
A	802.11n/ac/ax (40MHz)/ 802.11ax (40MHz RU 484)		38 to 46	38, 46	OFDM, OFDMA	MCS0
A	802.11ac/ax (80MHz)/ 802.11ax (80MHz RU 996)		42	42	OFDM, OFDMA	MCS0
A	802.11ax(160M FULL)		50	50	OFDMA	MCS0
A	802.11a	5260-5320	52 to 64	52, 60, 64	OFDM	6.0
A	802.11n/ac/ax (20MHz)/ 802.11ax (20MHz RU 26/52/106/242)		52 to 64	52, 60, 64	OFDM, OFDMA	MCS0
A	802.11n/ac/ax (40MHz)/ 802.11ax (40MHz RU 484)		54 to 62	54, 62	OFDM, OFDMA	MCS0
A	802.11ac/ax (80MHz)/ 802.11ax (80MHz RU 996)		58	58	OFDM, OFDMA	MCS0
A	802.11a	5500-5720	100 to 140	100, 116, 140	OFDM	6.0
A	802.11n/ac/ax (20MHz)/ 802.11ax (20MHz RU 26/52/106/242)		100 to 140	100, 116, 140	OFDM, OFDMA	MCS0
A	802.11n/ac/ax (40MHz)/ 802.11ax (40MHz RU 484)		102 to 134	102, 110, 134	OFDM, OFDMA	MCS0
A	802.11ac/ax (80MHz)/ 802.11ax (80MHz RU 996)		106 to 122	106, 122	OFDM, OFDMA	MCS0
A	802.11ax(160M FULL)		114	114	OFDMA	MCS0
A	802.11a	5745-5825	149 to 165	149, 157, 165	OFDM	6.0
A	802.11n/ac/ax (20MHz)/ 802.11ax (20MHz RU 26/52/106/242)		149 to 165	149, 157, 165	OFDM, OFDMA	MCS0
A	802.11n/ac/ax (40MHz)/ 802.11ax (40MHz RU 484)		151 to 159	151, 159	OFDM, OFDMA	MCS0
A	802.11ac/ax (80MHz)/ 802.11ax (80MHz RU 996)		155	155	OFDM, OFDMA	MCS0



POWER LINE CONDUCTED EMISSION TEST:

- Pre-Scan has been conducted to determine the worst-case mode from all possible combinations between available modulations, data rates and antenna ports (if EUT with antenna diversity architecture).
- The following channel(s) was (were) selected for the final test as listed below.

EUT CONFIGURE MODE	MODE	FREQ. BAND (MHz)	AVAILABLE CHANNEL	TESTED CHANNEL	MODULATION	DATA RATE (Mbps)
A	802.11ax (40MHz)	5260-5320	54 to 62	62	OFDM	MCS0

BANDEDGE MEASUREMENT:

- Pre-Scan has been conducted to determine the worst-case mode from all possible combinations between available modulations, data rates and antenna ports (if EUT with antenna diversity architecture).
- The following channel(s) was (were) selected for the final test as listed below.

EUT CONFIGURE MODE	MODE	FREQ. BAND (MHz)	AVAILABLE CHANNEL	TESTED CHANNEL	MODULATION	DATA RATE (Mbps)
A	802.11a	5180-5240	36 to 48	36, 40, 48	OFDM	6.0
A	802.11n/ac/ax (20MHz)/ 802.11ax (20MHz RU 26/52/106/242)		36 to 48	36, 40, 48	OFDM, OFDMA	MCS0
A	802.11n/ac/ax (40MHz)/ 802.11ax (40MHz RU 484)		38 to 46	38, 46	OFDM, OFDMA	MCS0
A	802.11ac/ax (80MHz)/ 802.11ax (80MHz RU 996)		42	42	OFDM, OFDMA	MCS0
A	802.11ax(160M FULL)		50	50	OFDMA	MCS0
A	802.11a	5260-5320	52 to 64	52, 60, 64	OFDM	6.0
A	802.11n/ac/ax (20MHz)/ 802.11ax (20MHz RU 26/52/106/242)		52 to 64	52, 60, 64	OFDM, OFDMA	MCS0
A	802.11n/ac/ax (40MHz)/ 802.11ax (40MHz RU 484)		54 to 62	54, 62	OFDM, OFDMA	MCS0
A	802.11ac/ax (80MHz)/ 802.11ax (80MHz RU 996)		58	58	OFDM, OFDMA	MCS0
A	802.11a	5500-5720	100 to 140	100, 116, 140	OFDM	6.0
A	802.11n/ac/ax (20MHz)/ 802.11ax (20MHz RU 26/52/106/242)		100 to 140	100, 116, 140	OFDM, OFDMA	MCS0



A	802.11n/ac/ax (40MHz)/ 802.11ax (40MHz RU 484)		102 to 134	102, 110, 134	OFDM, OFDMA	MCS0
A	802.11ac/ax (80MHz)/ 802.11ax (80MHz RU 996)		100 to 140	100, 116, 140	OFDM, OFDMA	MCS0
A	802.11ax(160M FULL)		114	114	OFDMA	MCS0
A	802.11a		149 to 165	149, 157,165	OFDM	6.0
A	802.11n/ac/ax (20MHz)/ 802.11ax (20MHz RU 26/52/106/242)		149 to 165	149, 157,165	OFDM, OFDMA	MCS0
A	802.11n/ac/ax (40MHz)/ 802.11ax (40MHz RU 484)	5745-5825	151 to 159	151, 159	OFDM, OFDMA	MCS0
A	802.11ac/ax (80MHz)/ 802.11ax (80MHz RU 996)		155	155	OFDM, OFDMA	MCS0



ANTENNA PORT CONDUCTED MEASUREMENT:

- This item includes all test value of each mode, but only includes spectrum plot of worst value of each mode.
- Pre-Scan has been conducted to determine the worst-case mode from all possible combinations between available modulations, data rates and antenna ports (if EUT with antenna diversity architecture).
- The following channel(s) was (were) selected for the final test as listed below.

EUT CONFIGURE MODE	MODE	FREQ. BAND (MHz)	AVAILABLE CHANNEL	TESTED CHANNEL	MODULATION	DATA RATE (Mbps)
A	802.11a	5180-5240	36 to 48	36, 40, 48	OFDM	6.0
A	802.11n/ac/ax (20MHz)/ 802.11ax (20MHz RU 26/52/106/242)		36 to 48	36, 40, 48	OFDM, OFDMA	MCS0
A	802.11n/ac/ax (40MHz)/ 802.11ax (40MHz RU 484)		38 to 46	38, 46	OFDM, OFDMA	MCS0
A	802.11ac/ax (80MHz)/ 802.11ax (80MHz RU 996)		42	42	OFDM, OFDMA	MCS0
A	802.11ax(160M FULL)		50	50	OFDMA	MCS0
A	802.11a	5260-5320	52 to 64	52, 60, 64	OFDM	6.0
A	802.11n/ac/ax (20MHz)/ 802.11ax (20MHz RU 26/52/106/242)		52 to 64	52, 60, 64	OFDM, OFDMA	MCS0
A	802.11n/ac/ax (40MHz)/ 802.11ax (40MHz RU 484)		54 to 62	54, 62	OFDM, OFDMA	MCS0
A	802.11ac/ax (80MHz)/ 802.11ax (80MHz RU 996)		58	58	OFDM, OFDMA	MCS0
A	802.11a	5500-5720	100 to 140	100, 116, 140	OFDM	6.0
A	802.11n/ac/ax (20MHz)/ 802.11ax (20MHz RU 26/52/106/242)		100 to 140	100, 116, 140	OFDM, OFDMA	MCS0
A	802.11n/ac/ax (40MHz)/ 802.11ax (40MHz RU 484)		102 to 134	102, 110, 134	OFDM, OFDMA	MCS0
A	802.11ac/ax (80MHz)/ 802.11ax (80MHz RU 996)		106 to 138	106, 138	OFDM, OFDMA	MCS0
A	802.11ax(160M FULL)		114	114	OFDMA	MCS0
A	802.11a	5745-5825	149 to 165	149, 157,165	OFDM	6.0
A	802.11n/ac/ax (20MHz)/ 802.11ax (20MHz RU		149 to 165	149, 157,165	OFDM,	MCS0



**BUREAU
VERITAS**

Test Report No.: W7L-P24030005RF03

	26/52/106/242)				OFDMA	
A	802.11n/ac/ax (40MHz)/ 802.11ax (40MHz RU 484)		151 to 159	151, 159	OFDM, OFDMA	MCS0
A	802.11ac/ax (80MHz)/ 802.11ax (80MHz RU 996)		155	155	OFDM, OFDMA	MCS0

TEST CONDITION:

APPLICABLE TO	ENVIRONMENTAL CONDITIONS	INPUT POWER	TESTED BY
RE<1G	23deg. C, 70%RH	DC 5V By Adapter	Jace Hu
RE≥1G	23deg. C, 70%RH	DC 5V By Adapter	Jace Hu
PLC	25deg. C, 52%RH	DC 5V By Adapter	James Fu
APCM	25deg. C, 60%RH	DC 3.84V By DC Supply	James Fu



Test Report No.: W7L-P24030005RF03

2.3 DUTY CYCLE OF TEST SIGNAL

Please Refer to Appendix A/B Of this test report.



2.4 DESCRIPTION OF SUPPORT UNITS

The EUT has been tested as an independent unit together with other necessary accessories or support units. The following support units or accessories were used to form a representative test configuration during the tests.

NO.	PRODUCT	BRAND	MODEL NO.	SERIAL NO.	FCC ID
1	Desktop	Lenovo	M73 SFF	PC04GRQV	N/A
2	Desktop	Lenovo	M73 SFF	PC06CS27	N/A
3	Laptop	Lenovo	ThinkpadL440	R90FTFKN	N/A
4	DC source	Kikusui/JP	PMX18-5A	0000001	N/A

NO.	SIGNAL CABLE DESCRIPTION OF THE ABOVE SUPPORT UNITS
1	AC Line: Unshielded, Detachable 1.5m
2	AC Line: Unshielded, Detachable 1.5m
3	AC Line: Unshielded, Detachable 1.5m
4	DC Line: Unshielded, Detachable 1.0m



2.4.1 CONFIGURATION OF SYSTEM UNDER TEST

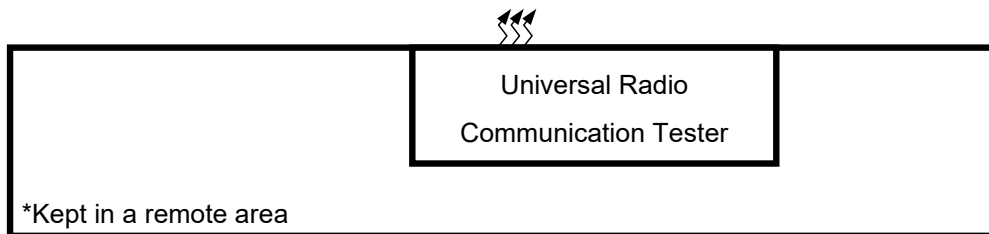
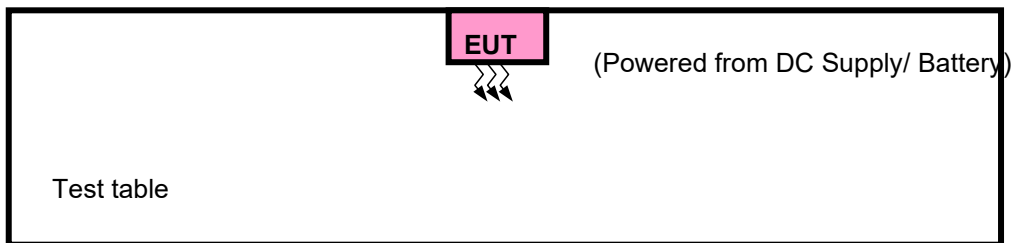
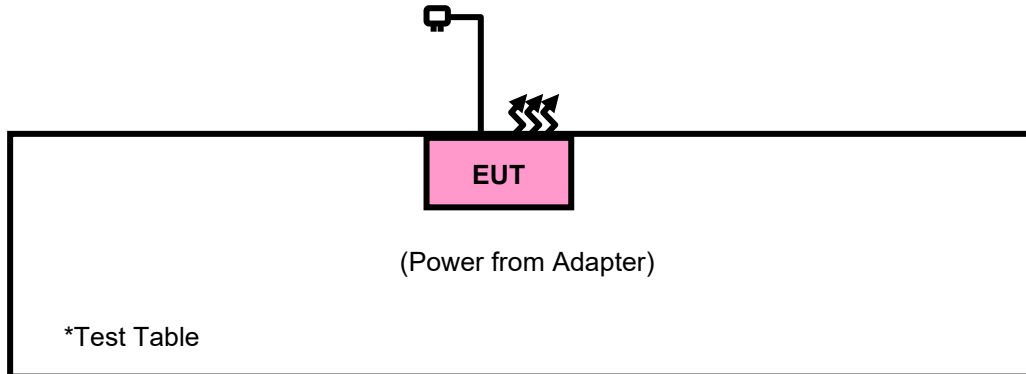



2.5 GENERAL DESCRIPTION OF APPLIED STANDARDS

The EUT is a RF Product. According to the specifications of the manufacturer, it must comply with the requirements of the following standards:

FCC Part 15, Subpart E (15.407)

KDB 789033 D02 General U-NII Test Procedures New Rules v02r01

ANSI C63.10-2020

All test items have been performed and recorded as per the above standards.

NOTE: The EUT is also considered as a kind of computer peripheral, because the connection to computer is necessary for typical use. It has been verified to comply with the requirements of FCC Part 15, Subpart B, Class B (Certification). The test report has been issued separately.



3 TEST TYPES AND RESULTS

3.1 RADIATED EMISSION AND BANDEDGE MEASUREMENT

3.1.1 LIMITS OF RADIATED EMISSION AND BANDEDGE MEASUREMENT

Radiated emissions which fall in the restricted bands must comply with the radiated emission limits specified as below table:

FREQUENCIES (MHz)	FIELD STRENGTH (microvolts/meter)	MEASUREMENT DISTANCE (meters)
0.009 ~ 0.490	2400/F(kHz)	300
0.490 ~ 1.705	24000/F(kHz)	30
1.705 ~ 30.0	30	30
30 ~ 88	100	3
88 ~ 216	150	3
216 ~ 960	200	3
Above 960	500	3

NOTE:

1. The lower limit shall apply at the transition frequencies.
2. Emission level (dBuV/m) = 20 log Emission level (uV/m).
3. For frequencies above 1000MHz, the field strength limits are based on average detector, however, the peak field strength of any emission shall not exceed the maximum permitted average limits, specified above by more than 20dB under any condition of modulation.

3.1.2 LIMITS OF UNWANTED EMISSION

RESTRICTED BANDS	APPLICABLE TO	LIMIT	
	789033 D02 General UNII Test Procedures New Rules v02r01	FIELD STRENGTH AT 3m (dBµV/m)	
	PK : 74	AV : 54	
OUT OF THE RESTRICTED BANDS	APPLICABLE TO	EIRP LIMIT (dBm/MHz)	EQUIVALENT FIELD STRENGTH AT 3m (dBµV/m)
	15.407(b)(1)	PK : -27	PK : 68.2
	15.407(b)(2)		
	15.407(b)(3)		
	15.407(b)(4)	See note 2 (FCC 16-24)	



NOTE: The following formula is used to convert the equipment isotropic radiated power (eirp) to field strength:

$$E = \frac{1000000 \sqrt{30P}}{3} \text{ } \mu\text{V/m, where P is the eirp (Watts).}$$

2. All emissions shall be limited to a level of -27 dBm/MHz at 75 MHz or more above or below the band edge increasing linearly to 10 dBm/MHz at 25 MHz above or below the band edge, and from 25 MHz above or below the band edge increasing linearly to a level of 15.6 dBm/MHz at 5 MHz above or below the band edge, and from 5 MHz above or below the band edge increasing linearly to a level of 27 dBm/MHz at the band edge.

3.1.3 TEST INSTRUMENTS

Equipment	Manufacturer	Model No.	Serial No.	Last Cal.	Next Cal.
3m Semi-anechoic Chamber	ETS-LINDGREN	9m*6m*6m	Euroshieldpn-CT0001143-1216	Nov. 14,23	Nov. 13,26
Bilog Antenna	ETS-LINDGREN	3143B	00161965	Feb. 18,24	Feb. 17,25
Horn Antenna	ETS-LINDGREN	3117	00168692	Feb. 18,24	Feb. 17,25
Horn Antenna (18GHz-40GHz)	N/A	QWH-SL-18-40-K-SG/QMS-00361	15433	Sep.04, 23	Sep.03, 24
Test Software	E3	V 9.160323	N/A	N/A	N/A
Test Software	JS1120-3	3.2.06	N/A	N/A	N/A
10dB Attenuator	JFW/USA	50HF-010-SMA	N/A	May. 06,24	May. 05,25
MXE EMI Receiver	KEYSIGHT	N9038A-544	MY54450026	Mar. 28,23	Mar. 27,24
MXE EMI Receiver	KEYSIGHT	N9038A-544	MY54450026	Mar. 27,24	Mar. 26,25
Signal Pre-Amplifier	EMSI	EMC 9135	980249	May. 06,23	May. 05,24
Signal Pre-Amplifier	EMSI	EMC 012645B	980257	May.10,23	May.09,24
Signal Pre-Amplifier	EMSI	EMC 184045B	980259	Feb. 17,24	Feb. 16,25
DC Source	Kikusui/JP	PMX18-5A	0000001	Aug. 12,23	Aug. 11,24
Power Meter	Anritsu	ML2495A	1506002	Feb. 14,24	Feb. 13,25
Power Sensor	Anritsu	MA2411B	1339352	Feb. 14,24	Feb. 13,25
Loop Antenna	Schwarzbeck	FMZB 1519B	00173	Sep.03,23	Sep.02,24

- NOTE:**
1. The calibration interval of the above test instruments is 12 months or 36 months and the calibrations are traceable to CEPREI/CHINA, GRGT/CHINA and NIM/CHINA.
 2. The test was performed in 3m Chamber.
 3. The FCC Site Registration No. is 525120; The Designation No. is CN1171.



3.1.4 TEST PROCEDURES

- a. The EUT was placed on the top of a rotating table 0.8 meters (for below 1GHz) / 1.5 meters (for above 1GHz) above the ground at 3 meter chamber room for test. The table was rotated 360 degrees to determine the position of the highest radiation.
- b. The EUT was set 3 meters away from the interference-receiving antenna, which was mounted on the top of a variable-height antenna tower.
- c. The antenna is a broadband antenna, and its height is varied from one meter to four meters above the ground to determine the maximum value of the field strength. Both horizontal and vertical polarizations of the antenna are set to make the measurement.
- d. For each suspected emission, the EUT was arranged to its worst case and then the antenna was tuned to heights from 1 meter to 4 meters and the rotatable table was turned from 0 degrees to 360 degrees to find the maximum reading.
- e. The test-receiver system was set to Peak Detect Function and Specified Bandwidth with Maximum Hold Mode.
- f. If the emission level of the EUT in peak mode was 10dB lower than the limit specified, then testing could be stopped and the peak values of the EUT would be reported. Otherwise the emissions that did not have 10dB margin would be re-tested one by one using peak, quasi-peak or average method as specified and then reported in a data sheet.

NOTE:

1. The resolution bandwidth and video bandwidth of test receiver/spectrum analyzer is 120kHz for Peak detection (PK) and Quasi-peak detection (QP) at frequency below 1GHz.
2. The resolution bandwidth of test receiver/spectrum analyzer is 1MHz and video bandwidth is 3MHz for Peak detection at frequency above 1GHz.
3. The resolution bandwidth of test receiver/spectrum analyzer is 1MHz and the video bandwidth is 3MHz for RMS Average (Duty cycle < 98%) for Average detection (AV) at frequency above 1GHz, then the measurement results was added to a correction factor ($10 \log(1/\text{duty cycle})$).
4. The resolution bandwidth of test receiver/spectrum analyzer is 1MHz and the video bandwidth is 10Hz (Duty cycle \geq 98%) for Average detection (AV) at frequency above 1GHz.
5. All modes of operation were investigated and the worst-case emissions are reported.

3.1.5 DEVIATION FROM TEST STANDARD

No deviation.



3.1.6 TEST SETUP

<Frequency Range 9KHz~30MHz >

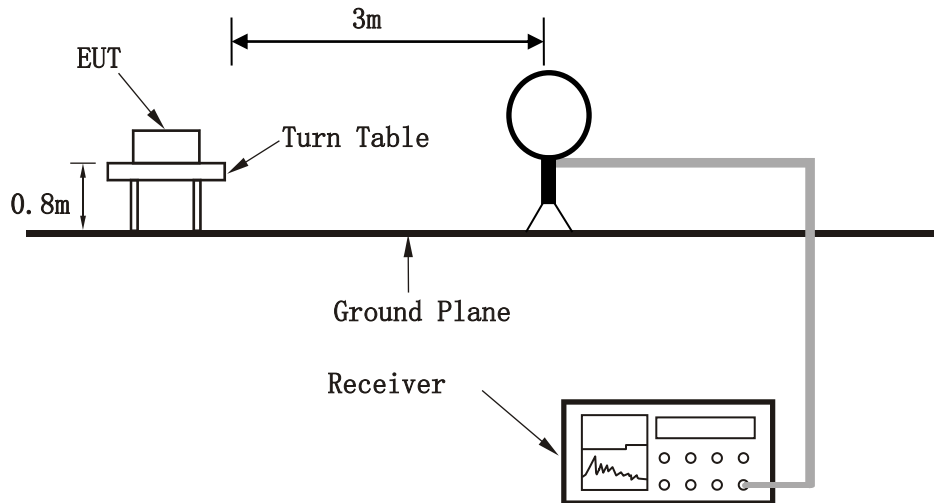

< Frequency Range 30MHz~1GHz >

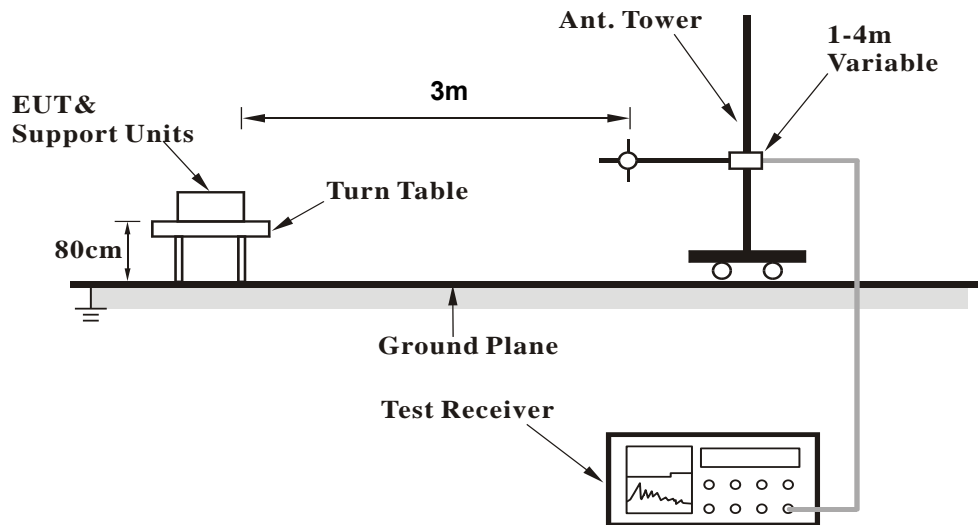

<Frequency Range above 1GHz>

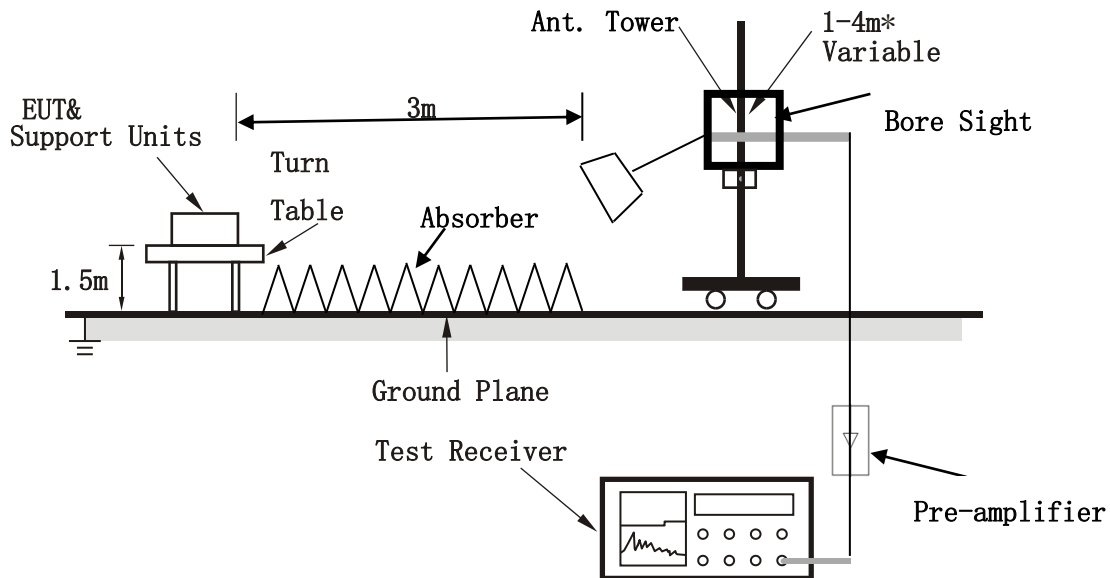

Note: Above 1G is a directional antenna

Depends on the EUT height and the antenna 3dB beamwidth both, refer to section 7.3 of CISPR 16-2-3.

For the actual test configuration, please refer to the attached file (Test Setup Photo).

3.1.7 EUT OPERATING CONDITION

- a. Set the EUT under full load condition and placed them on a testing table.
- b. Set the transmitter part of EUT under transmission condition continuously at specific channel frequency.
- c. The necessary accessories enable the EUT in full functions.



3.1.8 TEST RESULTS

NOTE : The 9K~30MHz amplitude of spurious emissions attenuated more than 20 dB below the permissible value is not required in the report.

30 MHz – 1GHz data:

Band 2

802.11ax (40MHz):

CHANNEL	TX Channel 62	DETECTOR FUNCTION	Quasi-Peak (QP)
FREQUENCY RANGE	30MHz ~ 1GHz		

ANTENNA POLARITY & TEST DISTANCE: HORIZONTAL AT 3 M										
FREQ. (MHz)	EMISSION LEVEL (dBuV/m)	READ LEVEL (dBuV)	LIMIT (dBuV/m)	MARGIN (dB)	ANTENNA FACTOR (dB /m)	CABLE LOSS (dB)	PREAMP FACTOR (dB)	ANTENNA HEIGHT (cm)	TABLE ANGLE (Degree)	REMARK
33.88	22.94	35.46	40	-17.06	18.69	6.18	37.39	100	360	QP
143.49	28.94	49.54	43.5	-14.56	9.51	6.74	36.85	100	360	QP
163.86	31.36	49.01	43.5	-12.14	12.33	6.79	36.77	100	360	QP
288.02	26.35	41.55	46	-19.65	14.13	7.28	36.61	100	360	QP
479.11	29.64	40.49	46	-16.36	18.3	7.87	37.02	100	360	QP
719.67	33.63	39.73	46	-12.37	22.82	8.42	37.34	100	360	QP

REMARKS:

1. Emission level (dBuV/m) = Read level (dBuV) + Correction Factor (dB/m).
2. Correction Factor (dB/m) = Antenna Factor (dB/m) + Cable Factor (dB).
3. The other emission levels were very low against the limit.
4. Margin value = Emission level – Limit value.

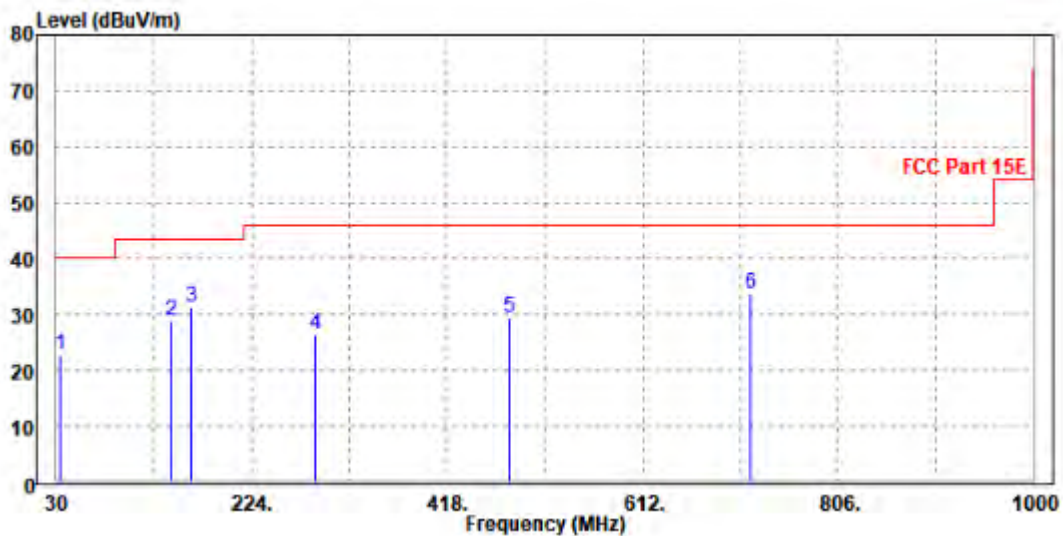



CHANNEL	Channel 62	DETECTOR FUNCTION	Quasi-Peak (QP)
FREQUENCY RANGE	30MHz ~ 1GHz		

ANTENNA POLARITY & TEST DISTANCE: VERTICAL AT 3 M										
FREQ. (MHz)	EMISSION LEVEL (dBuV/m)	READ LEVEL (dBuV)	LIMIT (dBuV/m)	MARGIN (dB)	ANTENNA FACTOR (dB /m)	CABLE LOSS (dB)	PREAMP FACTOR (dB)	ANTENNA HEIGHT (cm)	TABLE ANGLE (Degree)	REMARK
30.97	32.12	43.11	40	-7.88	20.24	6.14	37.37	100	0	QP
143.49	27.12	45.57	43.5	-16.38	11.66	6.74	36.85	100	0	QP
163.86	30.61	46.18	43.5	-12.89	14.41	6.79	36.77	100	0	QP
435.46	29.5	40.45	46	-16.5	18.27	7.7	36.92	100	0	QP
480.08	29.3	39.33	46	-16.7	19.12	7.87	37.02	100	0	QP
600.36	30.55	38.99	46	-15.45	20.51	8.22	37.17	100	0	QP

REMARKS:

1. Emission level (dBuV/m) = Read level (dBuV) + Correction Factor (dB/m).
2. Correction Factor (dB/m) = Antenna Factor (dB/m) + Cable Factor (dB).
3. The other emission levels were very low against the limit.
4. Margin value = Emission level – Limit value.

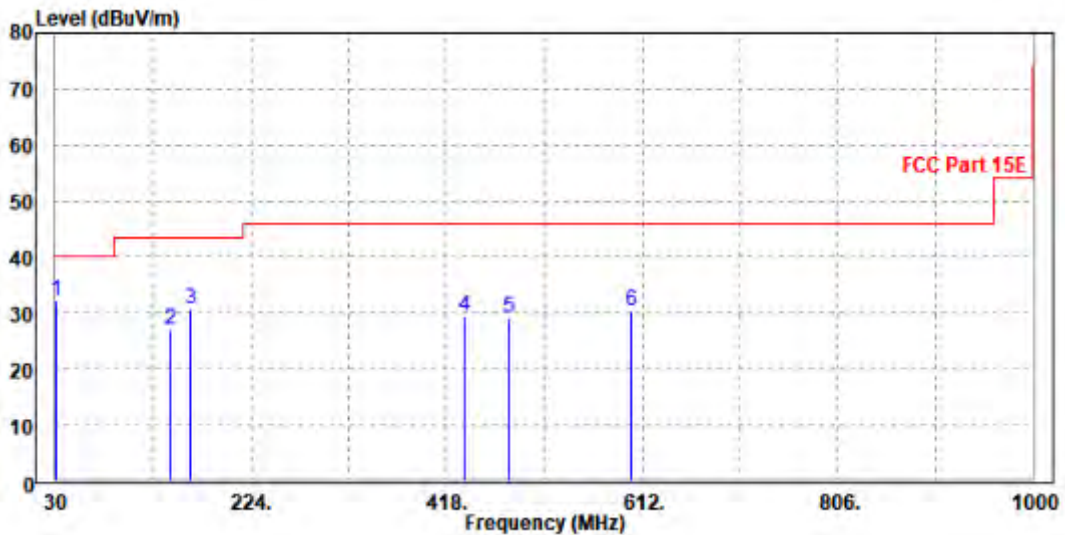



ABOVE 1GHz WORST-CASE DATA:

Note: For higher frequency, the emission is too low to be detected.

Band 1

802.11a

CHANNEL	TX Channel 36	DETECTOR FUNCTION	Peak (PK)
FREQUENCY RANGE	1GHz ~ 40GHz		Average (AV)

ANTENNA POLARITY & TEST DISTANCE: HORIZONTAL AT 3 M										
FREQ. (MHz)	EMISSION LEVEL (dBuV/m)	READ LEVEL (dBuV)	LIMIT (dBuV/m)	MARGIN (dB)	ANTENNA FACTOR (dB /m)	CABLE LOSS (dB)	PREAMP FACTOR (dB)	ANTENNA HEIGHT (cm)	TABLE ANGLE (Degree)	REMARK
5150	52.36	53.45	74	-21.64	34.26	11.17	46.52	100	340	Peak
5150	48.27	49.36	54	-5.73	34.26	11.17	46.52	100	340	Average
5180	102.37	103.43	/	/	34.27	11.2	46.53	100	340	Peak
5180	96.29	97.35	/	/	34.27	11.2	46.53	100	340	Average
5350	51.82	52.67	74	-22.18	34.34	11.39	46.58	100	340	Peak
5350	47.31	48.16	54	-6.69	34.34	11.39	46.58	100	340	Average
ANTENNA POLARITY & TEST DISTANCE: VERTICAL AT 3 M										
FREQ. (MHz)	EMISSION LEVEL (dBuV/m)	READ LEVEL (dBuV)	LIMIT (dBuV/m)	MARGIN (dB)	ANTENNA FACTOR (dB /m)	CABLE LOSS (dB)	PREAMP FACTOR (dB)	ANTENNA HEIGHT (cm)	TABLE ANGLE (Degree)	REMARK
5150	57.42	58.35	74	-16.58	34.42	11.17	46.52	100	295	Peak
5150	50.39	51.32	54	-3.61	34.42	11.17	46.52	100	295	Average
5180	109.64	110.53	/	/	34.44	11.2	46.53	100	295	Peak
5180	102.77	103.66	/	/	34.44	11.2	46.53	100	295	Average
5350	52.04	52.65	74	-21.96	34.58	11.39	46.58	100	295	Peak
5350	47.43	48.04	54	-6.57	34.58	11.39	46.58	100	295	Average

REMARKS:

1. Emission Level = Read Level+ Antenna Factor + Cable Loss- Preamp Factor
Margin value = Emission level – Limit value.
2. 5180MHz: Fundamental frequency.



CHANNEL	TX Channel 40	DETECTOR FUNCTION	Peak (PK)
FREQUENCY RANGE	1GHz ~ 40GHz		Average (AV)

ANTENNA POLARITY & TEST DISTANCE: HORIZONTAL AT 3 M										
FREQ. (MHz)	EMISSION LEVEL (dBuV/m)	READ LEVEL (dBuV)	LIMIT (dBuV/m)	MARGIN (dB)	ANTENNA FACTOR (dB /m)	CABLE LOSS (dB)	PREAMP FACTOR (dB)	ANTENNA HEIGHT (cm)	TABLE ANGLE (Degree)	REMARK
5150	52.16	53.25	74	-21.84	34.26	11.17	46.52	100	350	Peak
5150	47.38	48.47	54	-6.62	34.26	11.17	46.52	100	350	Average
5200	101.83	102.87	/	/	34.28	11.22	46.54	100	350	Peak
5200	94.33	95.37	/	/	34.28	11.22	46.54	100	350	Average
5350	51.86	52.71	74	-22.14	34.34	11.39	46.58	100	350	Peak
5350	47.5	48.35	54	-6.5	34.34	11.39	46.58	100	350	Average
ANTENNA POLARITY & TEST DISTANCE: VERTICAL AT 3 M										
FREQ. (MHz)	EMISSION LEVEL (dBuV/m)	READ LEVEL (dBuV)	LIMIT (dBuV/m)	MARGIN (dB)	ANTENNA FACTOR (dB /m)	CABLE LOSS (dB)	PREAMP FACTOR (dB)	ANTENNA HEIGHT (cm)	TABLE ANGLE (Degree)	REMARK
5150	54.53	55.46	74	-19.47	34.42	11.17	46.52	100	295	Peak
5150	49.25	50.18	54	-4.75	34.42	11.17	46.52	100	295	Average
5200	110.11	110.97	/	/	34.46	11.22	46.54	100	295	Peak
5200	103.18	104.04	/	/	34.46	11.22	46.54	100	295	Average
5350	52.24	52.85	74	-21.76	34.58	11.39	46.58	100	295	Peak
5350	47.75	48.36	54	-6.25	34.58	11.39	46.58	100	295	Average

REMARKS:

1. Emission Level = Read Level+ Antenna Factor + Cable Loss- Preamp Factor
Margin value = Emission level – Limit value.
2. 5200MHz: Fundamental frequency.



CHANNEL	TX Channel 48	DETECTOR FUNCTION	Peak (PK)
FREQUENCY RANGE	1GHz ~ 40GHz		Average (AV)

ANTENNA POLARITY & TEST DISTANCE: HORIZONTAL AT 3 M										
FREQ. (MHz)	EMISSION LEVEL (dBuV/m)	READ LEVEL (dBuV)	LIMIT (dBuV/m)	MARGIN (dB)	ANTENNA FACTOR (dB /m)	CABLE LOSS (dB)	PREAMP FACTOR (dB)	ANTENNA HEIGHT (cm)	TABLE ANGLE (Degree)	REMARK
5150	53.4	54.49	74	-20.6	34.26	11.17	46.52	100	350	Peak
5150	47.03	48.12	54	-6.97	34.26	11.17	46.52	100	350	Average
5240	102.45	103.43	/	/	34.3	11.27	46.55	100	350	Peak
5240	95.41	96.39	/	/	34.3	11.27	46.55	100	350	Average
5350	52.8	53.65	74	-21.2	34.34	11.39	46.58	100	350	Peak
5350	47.41	48.26	54	-6.59	34.34	11.39	46.58	100	350	Average
ANTENNA POLARITY & TEST DISTANCE: VERTICAL AT 3 M										
FREQ. (MHz)	EMISSION LEVEL (dBuV/m)	READ LEVEL (dBuV)	LIMIT (dBuV/m)	MARGIN (dB)	ANTENNA FACTOR (dB /m)	CABLE LOSS (dB)	PREAMP FACTOR (dB)	ANTENNA HEIGHT (cm)	TABLE ANGLE (Degree)	REMARK
5150	52.71	53.64	74	-21.29	34.42	11.17	46.52	100	295	Peak
5150	47.1	48.03	54	-6.9	34.42	11.17	46.52	100	295	Average
5240	108.62	109.41	/	/	34.49	11.27	46.55	100	295	Peak
5240	101.57	102.36	/	/	34.49	11.27	46.55	100	295	Average
5350	53.53	54.14	74	-20.47	34.58	11.39	46.58	100	295	Peak
5350	47.8	48.41	54	-6.2	34.58	11.39	46.58	100	295	Average

REMARKS:

- Emission Level = Read Level+ Antenna Factor + Cable Loss- Preamp Factor
Margin value = Emission level – Limit value.
- 5240MHz: Fundamental frequency.



802.11n (20MHz)

CHANNEL	TX Channel 36	DETECTOR FUNCTION	Peak (PK)
FREQUENCY RANGE	1GHz ~ 40GHz		Average (AV)

ANTENNA POLARITY & TEST DISTANCE: HORIZONTAL AT 3 M										
FREQ. (MHz)	EMISSION LEVEL (dBuV/m)	READ LEVEL (dBuV)	LIMIT (dBuV/m)	MARGIN (dB)	ANTENNA FACTOR (dB /m)	CABLE LOSS (dB)	PREAMP FACTOR (dB)	ANTENNA HEIGHT (cm)	TABLE ANGLE (Degree)	REMARK
5150	53.75	54.84	74	-20.25	34.26	11.17	46.52	100	350	Peak
5150	47.36	48.45	54	-6.64	34.26	11.17	46.52	100	350	Average
5180	100.57	101.63	/	/	34.27	11.2	46.53	100	350	Peak
5180	93.97	95.03	/	/	34.27	11.2	46.53	100	350	Average
5350	53.38	54.23	74	-20.62	34.34	11.39	46.58	100	350	Peak
5350	47.54	48.39	54	-6.46	34.34	11.39	46.58	100	350	Average

ANTENNA POLARITY & TEST DISTANCE: VERTICAL AT 3 M										
FREQ. (MHz)	EMISSION LEVEL (dBuV/m)	READ LEVEL (dBuV)	LIMIT (dBuV/m)	MARGIN (dB)	ANTENNA FACTOR (dB /m)	CABLE LOSS (dB)	PREAMP FACTOR (dB)	ANTENNA HEIGHT (cm)	TABLE ANGLE (Degree)	REMARK
5150	53.85	54.78	74	-20.15	34.42	11.17	46.52	100	295	Peak
5150	47.53	48.46	54	-6.47	34.42	11.17	46.52	100	295	Average
5180	108.31	109.2	/	/	34.44	11.2	46.53	100	295	Peak
5180	102.53	103.42	/	/	34.44	11.2	46.53	100	295	Average
5350	53.65	54.26	74	-20.35	34.58	11.39	46.58	100	295	Peak
5350	47.74	48.35	54	-6.26	34.58	11.39	46.58	100	295	Average

REMARKS:

- Emission Level = Read Level+ Antenna Factor + Cable Loss- Preamp Factor
Margin value = Emission level – Limit value.
- 5180MHz: Fundamental frequency.



CHANNEL	TX Channel 40	DETECTOR FUNCTION	Peak (PK)
FREQUENCY RANGE	1GHz ~ 40GHz		Average (AV)

ANTENNA POLARITY & TEST DISTANCE: HORIZONTAL AT 3 M										
FREQ. (MHz)	EMISSION LEVEL (dBuV/m)	READ LEVEL (dBuV)	LIMIT (dBuV/m)	MARGIN (dB)	ANTENNA FACTOR (dB /m)	CABLE LOSS (dB)	PREAMP FACTOR (dB)	ANTENNA HEIGHT (cm)	TABLE ANGLE (Degree)	REMARK
5150	53.15	54.24	74	-20.85	34.26	11.17	46.52	100	350	Peak
5150	47.44	48.53	54	-6.56	34.26	11.17	46.52	100	350	Average
5200	101.55	102.59	/	/	34.28	11.22	46.54	100	350	Peak
5200	94.35	95.39	/	/	34.28	11.22	46.54	100	350	Average
5350	53.32	54.17	74	-20.68	34.34	11.39	46.58	100	350	Peak
5350	47.33	48.18	54	-6.67	34.34	11.39	46.58	100	350	Average
ANTENNA POLARITY & TEST DISTANCE: VERTICAL AT 3 M										
FREQ. (MHz)	EMISSION LEVEL (dBuV/m)	READ LEVEL (dBuV)	LIMIT (dBuV/m)	MARGIN (dB)	ANTENNA FACTOR (dB /m)	CABLE LOSS (dB)	PREAMP FACTOR (dB)	ANTENNA HEIGHT (cm)	TABLE ANGLE (Degree)	REMARK
5150	53.45	54.38	74	-20.55	34.42	11.17	46.52	100	295	Peak
5150	47.09	48.02	54	-6.91	34.42	11.17	46.52	100	295	Average
5200	108.78	109.64	/	/	34.46	11.22	46.54	100	295	Peak
5200	102.89	103.75	/	/	34.46	11.22	46.54	100	295	Average
5350	53.65	54.26	74	-20.35	34.58	11.39	46.58	100	295	Peak
5350	47.83	48.44	54	-6.17	34.58	11.39	46.58	100	295	Average

REMARKS:

- Emission Level = Read Level+ Antenna Factor + Cable Loss- Preamp Factor
Margin value = Emission level – Limit value.
- 5200MHz: Fundamental frequency.



CHANNEL	TX Channel 48	DETECTOR FUNCTION	Peak (PK)
FREQUENCY RANGE	1GHz ~ 40GHz		Average (AV)

ANTENNA POLARITY & TEST DISTANCE: HORIZONTAL AT 3 M

FREQ. (MHz)	EMISSION LEVEL (dBuV/m)	READ LEVEL (dBuV)	LIMIT (dBuV/m)	MARGIN (dB)	ANTENNA FACTOR (dB /m)	CABLE LOSS (dB)	PREAMP FACTOR (dB)	ANTENNA HEIGHT (cm)	TABLE ANGLE (Degree)	REMARK
5150	51.97	53.06	74	-22.03	34.26	11.17	46.52	100	350	Peak
5150	47.07	48.16	54	-6.93	34.26	11.17	46.52	100	350	Average
5240	102.05	103.03	/	/	34.3	11.27	46.55	100	350	Peak
5240	95.35	96.33	/	/	34.3	11.27	46.55	100	350	Average
5350	53.39	54.24	74	-20.61	34.34	11.39	46.58	100	350	Peak
5350	47.68	48.53	54	-6.32	34.34	11.39	46.58	100	350	Average

ANTENNA POLARITY & TEST DISTANCE: VERTICAL AT 3 M

FREQ. (MHz)	EMISSION LEVEL (dBuV/m)	READ LEVEL (dBuV)	LIMIT (dBuV/m)	MARGIN (dB)	ANTENNA FACTOR (dB /m)	CABLE LOSS (dB)	PREAMP FACTOR (dB)	ANTENNA HEIGHT (cm)	TABLE ANGLE (Degree)	REMARK
5150	52.68	53.61	74	-21.32	34.42	11.17	46.52	100	295	Peak
5150	47.39	48.32	54	-6.61	34.42	11.17	46.52	100	295	Average
5240	106.94	107.73	/	/	34.49	11.27	46.55	100	295	Peak
5240	100.5	101.29	/	/	34.49	11.27	46.55	100	295	Average
5350	54.56	55.17	74	-19.44	34.58	11.39	46.58	100	295	Peak
5350	47.95	48.56	54	-6.05	34.58	11.39	46.58	100	295	Average

REMARKS:

- Emission Level = Read Level+ Antenna Factor + Cable Loss- Preamp Factor
Margin value = Emission level – Limit value.
- 5240MHz: Fundamental frequency.



802.11n (40MHz)

CHANNEL	TX Channel 38	DETECTOR FUNCTION	Peak (PK)
FREQUENCY RANGE	1GHz ~ 40GHz		Average (AV)

ANTENNA POLARITY & TEST DISTANCE: HORIZONTAL AT 3 M										
FREQ. (MHz)	EMISSION LEVEL (dBuV/m)	READ LEVEL (dBuV)	LIMIT (dBuV/m)	MARGIN (dB)	ANTENNA FACTOR (dB /m)	CABLE LOSS (dB)	PREAMP FACTOR (dB)	ANTENNA HEIGHT (cm)	TABLE ANGLE (Degree)	REMARK
5150	52.54	53.63	74	-21.46	34.26	11.17	46.52	100	350	Peak
5150	48.11	49.2	54	-5.89	34.26	11.17	46.52	100	350	Average
5190	93.92	94.96	/	/	34.28	11.21	46.53	100	350	Peak
5190	88.26	89.3	/	/	34.28	11.21	46.53	100	350	Average
5350	52.1	52.95	74	-21.9	34.34	11.39	46.58	100	350	Peak
5350	47	47.85	54	-7	34.34	11.39	46.58	100	350	Average

ANTENNA POLARITY & TEST DISTANCE: VERTICAL AT 3 M										
FREQ. (MHz)	EMISSION LEVEL (dBuV/m)	READ LEVEL (dBuV)	LIMIT (dBuV/m)	MARGIN (dB)	ANTENNA FACTOR (dB /m)	CABLE LOSS (dB)	PREAMP FACTOR (dB)	ANTENNA HEIGHT (cm)	TABLE ANGLE (Degree)	REMARK
5150	54.27	55.2	74	-19.73	34.42	11.17	46.52	100	295	Peak
5150	50.43	51.36	54	-3.57	34.42	11.17	46.52	100	295	Average
5190	100.76	101.63	/	/	34.45	11.21	46.53	100	295	Peak
5190	96.84	97.71	/	/	34.45	11.21	46.53	100	295	Average
5350	52.33	52.94	74	-21.67	34.58	11.39	46.58	100	295	Peak
5350	46.75	47.36	54	-7.25	34.58	11.39	46.58	100	295	Average

REMARKS:

- Emission Level = Read Level+ Antenna Factor + Cable Loss- Preamp Factor
Margin value = Emission level – Limit value.
- 5190MHz: Fundamental frequency.



CHANNEL	TX Channel 46	DETECTOR FUNCTION	Peak (PK)
FREQUENCY RANGE	1GHz ~ 40GHz		Average (AV)

ANTENNA POLARITY & TEST DISTANCE: HORIZONTAL AT 3 M

FREQ. (MHz)	EMISSION LEVEL (dBuV/m)	READ LEVEL (dBuV)	LIMIT (dBuV/m)	MARGIN (dB)	ANTENNA FACTOR (dB /m)	CABLE LOSS (dB)	PREAMP FACTOR (dB)	ANTENNA HEIGHT (cm)	TABLE ANGLE (Degree)	REMARK
5150	52.66	53.75	74	-21.34	34.26	11.17	46.52	100	350	Peak
5150	47.17	48.26	54	-6.83	34.26	11.17	46.52	100	350	Average
5230	95.88	96.87	/	/	34.29	11.26	46.54	100	350	Peak
5230	90.17	91.16	/	/	34.29	11.26	46.54	100	350	Average
5350	52.28	53.13	74	-21.72	34.34	11.39	46.58	100	350	Peak
5350	47.66	48.51	54	-6.34	34.34	11.39	46.58	100	350	Average

ANTENNA POLARITY & TEST DISTANCE: VERTICAL AT 3 M

FREQ. (MHz)	EMISSION LEVEL (dBuV/m)	READ LEVEL (dBuV)	LIMIT (dBuV/m)	MARGIN (dB)	ANTENNA FACTOR (dB /m)	CABLE LOSS (dB)	PREAMP FACTOR (dB)	ANTENNA HEIGHT (cm)	TABLE ANGLE (Degree)	REMARK
5150	52.33	53.26	74	-21.67	34.42	11.17	46.52	100	295	Peak
5150	48.45	49.38	54	-5.55	34.42	11.17	46.52	100	295	Average
5230	103.47	104.27	/	/	34.48	11.26	46.54	100	295	Peak
5230	97.38	98.18	/	/	34.48	11.26	46.54	100	295	Average
5350	52.57	53.18	74	-21.43	34.58	11.39	46.58	100	295	Peak
5350	47.88	48.49	54	-6.12	34.58	11.39	46.58	100	295	Average

REMARKS:

- Emission Level = Read Level+ Antenna Factor + Cable Loss- Preamp Factor
Margin value = Emission level – Limit value.
- 5230MHz: Fundamental frequency.



802.11ax (20MHz)

CHANNEL	TX Channel 36	DETECTOR FUNCTION	Peak (PK)
FREQUENCY RANGE	1GHz ~ 40GHz		Average (AV)

ANTENNA POLARITY & TEST DISTANCE: HORIZONTAL AT 3 M										
FREQ. (MHz)	EMISSION LEVEL (dBuV/m)	READ LEVEL (dBuV)	LIMIT (dBuV/m)	MARGIN (dB)	ANTENNA FACTOR (dB /m)	CABLE LOSS (dB)	PREAMP FACTOR (dB)	ANTENNA HEIGHT (cm)	TABLE ANGLE (Degree)	REMARK
5150	53.36	54.45	74	-20.64	34.26	11.17	46.52	100	350	Peak
5150	47.44	48.53	54	-6.56	34.26	11.17	46.52	100	350	Average
5180	101.79	102.85	/	/	34.27	11.2	46.53	100	350	Peak
5180	93.65	94.71	/	/	34.27	11.2	46.53	100	350	Average
5350	53.1	53.95	74	-20.9	34.34	11.39	46.58	100	350	Peak
5350	47.03	47.88	54	-6.97	34.34	11.39	46.58	100	350	Average

ANTENNA POLARITY & TEST DISTANCE: VERTICAL AT 3 M										
FREQ. (MHz)	EMISSION LEVEL (dBuV/m)	READ LEVEL (dBuV)	LIMIT (dBuV/m)	MARGIN (dB)	ANTENNA FACTOR (dB /m)	CABLE LOSS (dB)	PREAMP FACTOR (dB)	ANTENNA HEIGHT (cm)	TABLE ANGLE (Degree)	REMARK
5150	53.7	54.63	74	-20.3	34.42	11.17	46.52	100	295	Peak
5150	49.24	50.17	54	-4.76	34.42	11.17	46.52	100	295	Average
5180	110.01	110.9	/	/	34.44	11.2	46.53	100	295	Peak
5180	101.48	102.37	/	/	34.44	11.2	46.53	100	295	Average
5350	52.5	53.11	74	-21.5	34.58	11.39	46.58	100	295	Peak
5350	47.32	47.93	54	-6.68	34.58	11.39	46.58	100	295	Average

REMARKS:

- Emission Level = Read Level+ Antenna Factor + Cable Loss- Preamp Factor
Margin value = Emission level – Limit value.
- 5180MHz: Fundamental frequency.



CHANNEL	TX Channel 40	DETECTOR FUNCTION	Peak (PK)
FREQUENCY RANGE	1GHz ~ 40GHz		Average (AV)

ANTENNA POLARITY & TEST DISTANCE: HORIZONTAL AT 3 M

FREQ. (MHz)	EMISSION LEVEL (dBuV/m)	READ LEVEL (dBuV)	LIMIT (dBuV/m)	MARGIN (dB)	ANTENNA FACTOR (dB /m)	CABLE LOSS (dB)	PREAMP FACTOR (dB)	ANTENNA HEIGHT (cm)	TABLE ANGLE (Degree)	REMARK
5150	52.55	53.64	74	-21.45	34.26	11.17	46.52	100	350	Peak
5150	46.87	47.96	54	-7.13	34.26	11.17	46.52	100	350	Average
5200	100.93	101.97	/	/	34.28	11.22	46.54	100	350	Peak
5200	93.98	95.02	/	/	34.28	11.22	46.54	100	350	Average
5350	52.78	53.63	74	-21.22	34.34	11.39	46.58	100	350	Peak
5350	47.4	48.25	54	-6.6	34.34	11.39	46.58	100	350	Average

ANTENNA POLARITY & TEST DISTANCE: VERTICAL AT 3 M

FREQ. (MHz)	EMISSION LEVEL (dBuV/m)	READ LEVEL (dBuV)	LIMIT (dBuV/m)	MARGIN (dB)	ANTENNA FACTOR (dB /m)	CABLE LOSS (dB)	PREAMP FACTOR (dB)	ANTENNA HEIGHT (cm)	TABLE ANGLE (Degree)	REMARK
5150	52.73	53.66	74	-21.27	34.42	11.17	46.52	100	295	Peak
5150	47.67	48.6	54	-6.33	34.42	11.17	46.52	100	295	Average
5200	109.7	110.56	/	/	34.46	11.22	46.54	100	295	Peak
5200	102	102.86	/	/	34.46	11.22	46.54	100	295	Average
5350	53.09	53.7	74	-20.91	34.58	11.39	46.58	100	295	Peak
5350	47.69	48.3	54	-6.31	34.58	11.39	46.58	100	295	Average

REMARKS:

1. Emission Level = Read Level+ Antenna Factor + Cable Loss- Preamp Factor
Margin value = Emission level – Limit value.
2. 5200MHz: Fundamental frequency.



CHANNEL	TX Channel 48	DETECTOR FUNCTION	Peak (PK)
FREQUENCY RANGE	1GHz ~ 40GHz		Average (AV)

ANTENNA POLARITY & TEST DISTANCE: HORIZONTAL AT 3 M

FREQ. (MHz)	EMISSION LEVEL (dBuV/m)	READ LEVEL (dBuV)	LIMIT (dBuV/m)	MARGIN (dB)	ANTENNA FACTOR (dB /m)	CABLE LOSS (dB)	PREAMP FACTOR (dB)	ANTENNA HEIGHT (cm)	TABLE ANGLE (Degree)	REMARK
5150	52.54	53.63	74	-21.46	34.26	11.17	46.52	100	350	Peak
5150	47.25	48.34	54	-6.75	34.26	11.17	46.52	100	350	Average
5240	102.05	103.03	/	/	34.3	11.27	46.55	100	350	Peak
5240	93.15	94.13	/	/	34.3	11.27	46.55	100	350	Average
5350	53.31	54.16	74	-20.69	34.34	11.39	46.58	100	350	Peak
5350	47.17	48.02	54	-6.83	34.34	11.39	46.58	100	350	Average

ANTENNA POLARITY & TEST DISTANCE: VERTICAL AT 3 M

FREQ. (MHz)	EMISSION LEVEL (dBuV/m)	READ LEVEL (dBuV)	LIMIT (dBuV/m)	MARGIN (dB)	ANTENNA FACTOR (dB /m)	CABLE LOSS (dB)	PREAMP FACTOR (dB)	ANTENNA HEIGHT (cm)	TABLE ANGLE (Degree)	REMARK
5150	51.88	52.81	74	-22.12	34.42	11.17	46.52	100	295	Peak
5150	47.19	48.12	54	-6.81	34.42	11.17	46.52	100	295	Average
5240	108.43	109.22	/	/	34.49	11.27	46.55	100	295	Peak
5240	100.73	101.52	/	/	34.49	11.27	46.55	100	295	Average
5350	52.99	53.6	74	-21.01	34.58	11.39	46.58	100	295	Peak
5350	48.66	49.27	54	-5.34	34.58	11.39	46.58	100	295	Average

REMARKS:

- Emission Level = Read Level+ Antenna Factor + Cable Loss- Preamp Factor
Margin value = Emission level – Limit value.
- 5240MHz: Fundamental frequency.



802.11ax (40MHz)

CHANNEL	TX Channel 38	DETECTOR FUNCTION	Peak (PK)
FREQUENCY RANGE	1GHz ~ 40GHz		Average (AV)

ANTENNA POLARITY & TEST DISTANCE: HORIZONTAL AT 3 M										
FREQ. (MHz)	EMISSION LEVEL (dBuV/m)	READ LEVEL (dBuV)	LIMIT (dBuV/m)	MARGIN (dB)	ANTENNA FACTOR (dB /m)	CABLE LOSS (dB)	PREAMP FACTOR (dB)	ANTENNA HEIGHT (cm)	TABLE ANGLE (Degree)	REMARK
5150	52.75	53.84	74	-21.25	34.26	11.17	46.52	100	350	Peak
5150	47.26	48.35	54	-6.74	34.26	11.17	46.52	100	350	Average
5190	95.32	96.36	/	/	34.28	11.21	46.53	100	350	Peak
5190	88.4	89.44	/	/	34.28	11.21	46.53	100	350	Average
5350	52.03	52.88	74	-21.97	34.34	11.39	46.58	100	350	Peak
5350	47	47.85	54	-7	34.34	11.39	46.58	100	350	Average

ANTENNA POLARITY & TEST DISTANCE: VERTICAL AT 3 M										
FREQ. (MHz)	EMISSION LEVEL (dBuV/m)	READ LEVEL (dBuV)	LIMIT (dBuV/m)	MARGIN (dB)	ANTENNA FACTOR (dB /m)	CABLE LOSS (dB)	PREAMP FACTOR (dB)	ANTENNA HEIGHT (cm)	TABLE ANGLE (Degree)	REMARK
5150	54.33	55.26	74	-19.67	34.42	11.17	46.52	100	295	Peak
5150	50.82	51.75	54	-3.18	34.42	11.17	46.52	100	295	Average
5190	101.75	102.62	/	/	34.45	11.21	46.53	100	295	Peak
5190	96.64	97.51	/	/	34.45	11.21	46.53	100	295	Average
5350	52.03	52.64	74	-21.97	34.58	11.39	46.58	100	295	Peak
5350	47.25	47.86	54	-6.75	34.58	11.39	46.58	100	295	Average

REMARKS:

- Emission Level = Read Level+ Antenna Factor + Cable Loss- Preamp Factor
Margin value = Emission level – Limit value.
- 5190MHz: Fundamental frequency.



CHANNEL	TX Channel 46	DETECTOR FUNCTION	Peak (PK)
FREQUENCY RANGE	1GHz ~ 40GHz		Average (AV)

ANTENNA POLARITY & TEST DISTANCE: HORIZONTAL AT 3 M										
FREQ. (MHz)	EMISSION LEVEL (dBuV/m)	READ LEVEL (dBuV)	LIMIT (dBuV/m)	MARGIN (dB)	ANTENNA FACTOR (dB /m)	CABLE LOSS (dB)	PREAMP FACTOR (dB)	ANTENNA HEIGHT (cm)	TABLE ANGLE (Degree)	REMARK
5150	52.1	53.19	74	-21.9	34.26	11.17	46.52	100	350	Peak
5150	47.44	48.53	54	-6.56	34.26	11.17	46.52	100	350	Average
5230	94.94	95.93	/	/	34.29	11.26	46.54	100	350	Peak
5230	89.73	90.72	/	/	34.29	11.26	46.54	100	350	Average
5350	51.79	52.64	74	-22.21	34.34	11.39	46.58	100	350	Peak
5350	47	47.85	54	-7	34.34	11.39	46.58	100	350	Average

ANTENNA POLARITY & TEST DISTANCE: VERTICAL AT 3 M										
FREQ. (MHz)	EMISSION LEVEL (dBuV/m)	READ LEVEL (dBuV)	LIMIT (dBuV/m)	MARGIN (dB)	ANTENNA FACTOR (dB /m)	CABLE LOSS (dB)	PREAMP FACTOR (dB)	ANTENNA HEIGHT (cm)	TABLE ANGLE (Degree)	REMARK
5150	52.2	53.13	74	-21.8	34.42	11.17	46.52	100	295	Peak
5150	47.42	48.35	54	-6.58	34.42	11.17	46.52	100	295	Average
5230	102.88	103.68	/	/	34.48	11.26	46.54	100	295	Peak
5230	95.55	96.35	/	/	34.48	11.26	46.54	100	295	Average
5350	53.48	54.09	74	-20.52	34.58	11.39	46.58	100	295	Peak
5350	47.02	47.63	54	-6.98	34.58	11.39	46.58	100	295	Average

REMARKS:

1. Emission Level = Read Level+ Antenna Factor + Cable Loss- Preamp Factor
Margin value = Emission level – Limit value.
2. 5230MHz: Fundamental frequency.



802.11ax (80MHz)

CHANNEL	TX Channel 42	DETECTOR FUNCTION	Peak (PK)
FREQUENCY RANGE	1GHz ~ 40GHz		Average (AV)

ANTENNA POLARITY & TEST DISTANCE: HORIZONTAL AT 3 M										
FREQ. (MHz)	EMISSION LEVEL (dBuV/m)	READ LEVEL (dBuV)	LIMIT (dBuV/m)	MARGIN (dB)	ANTENNA FACTOR (dB /m)	CABLE LOSS (dB)	PREAMP FACTOR (dB)	ANTENNA HEIGHT (cm)	TABLE ANGLE (Degree)	REMARK
5150	51.79	52.88	74	-22.21	34.26	11.17	46.52	100	350	Peak
5150	47.78	48.87	54	-6.22	34.26	11.17	46.52	100	350	Average
5210	93.76	94.78	/	/	34.28	11.24	46.54	100	350	Peak
5210	85.74	86.76	/	/	34.28	11.24	46.54	100	350	Average
5350	51.72	52.57	74	-22.28	34.34	11.39	46.58	100	350	Peak
5350	46.83	47.68	54	-7.17	34.34	11.39	46.58	100	350	Average

ANTENNA POLARITY & TEST DISTANCE: VERTICAL AT 3 M										
FREQ. (MHz)	EMISSION LEVEL (dBuV/m)	READ LEVEL (dBuV)	LIMIT (dBuV/m)	MARGIN (dB)	ANTENNA FACTOR (dB /m)	CABLE LOSS (dB)	PREAMP FACTOR (dB)	ANTENNA HEIGHT (cm)	TABLE ANGLE (Degree)	REMARK
5150	54.02	54.95	74	-19.98	34.42	11.17	46.52	100	295	Peak
5150	50.93	51.86	54	-3.07	34.42	11.17	46.52	100	295	Average
5210	99.36	100.19	/	/	34.47	11.24	46.54	100	295	Peak
5210	93.02	93.85	/	/	34.47	11.24	46.54	100	295	Average
5350	52.24	52.85	74	-21.76	34.58	11.39	46.58	100	295	Peak
5350	47.28	47.89	54	-6.72	34.58	11.39	46.58	100	295	Average

REMARKS:

- Emission Level = Read Level+ Antenna Factor + Cable Loss- Preamp Factor
Margin value = Emission level – Limit value.
- 5210MHz: Fundamental frequency.



802.11ax (160MHz)

CHANNEL	TX Channel 50	DETECTOR FUNCTION	Peak (PK)
FREQUENCY RANGE	1GHz ~ 40GHz		Average (AV)

ANTENNA POLARITY & TEST DISTANCE: HORIZONTAL AT 3 M										
FREQ. (MHz)	EMISSION LEVEL (dBuV/m)	READ LEVEL (dBuV)	LIMIT (dBuV/m)	MARGIN (dB)	ANTENNA FACTOR (dB /m)	CABLE LOSS (dB)	PREAMP FACTOR (dB)	ANTENNA HEIGHT (cm)	TABLE ANGLE (Degree)	REMARK
5150	52.54	53.63	74	-21.46	34.26	11.17	46.52	100	350	Peak
5150	48.63	49.72	54	-5.37	34.26	11.17	46.52	100	350	Average
5250	91.12	92.09	/	/	34.3	11.28	46.55	100	350	Peak
5250	85.38	86.35	/	/	34.3	11.28	46.55	100	350	Average
5350	53.41	54.26	74	-20.59	34.34	11.39	46.58	100	350	Peak
5350	48.11	48.96	54	-5.89	34.34	11.39	46.58	100	350	Average

ANTENNA POLARITY & TEST DISTANCE: VERTICAL AT 3 M										
FREQ. (MHz)	EMISSION LEVEL (dBuV/m)	READ LEVEL (dBuV)	LIMIT (dBuV/m)	MARGIN (dB)	ANTENNA FACTOR (dB /m)	CABLE LOSS (dB)	PREAMP FACTOR (dB)	ANTENNA HEIGHT (cm)	TABLE ANGLE (Degree)	REMARK
5150	53.74	54.67	74	-20.26	34.42	11.17	46.52	100	295	Peak
5150	50.32	51.25	54	-3.68	34.42	11.17	46.52	100	295	Average
5250	96.71	97.48	/	/	34.5	11.28	46.55	100	295	Peak
5250	90.11	90.88	/	/	34.5	11.28	46.55	100	295	Average
5350	53.72	54.33	74	-20.28	34.58	11.39	46.58	100	295	Peak
5350	50.46	51.07	54	-3.54	34.58	11.39	46.58	100	295	Average

REMARKS:

- Emission Level = Read Level+ Antenna Factor + Cable Loss- Preamp Factor
Margin value = Emission level – Limit value.
- 5250MHz: Fundamental frequency.



802.11ax (80MHz)

Worst case harmonic:

CHANNEL	TX Channel 42	DETECTOR FUNCTION	Peak (PK)
FREQUENCY RANGE	1GHz ~ 40GHz		Average (AV)

ANTENNA POLARITY & TEST DISTANCE: HORIZONTAL AT 3 M

	Freq	Level	Read Level	Limit Line	Over Limit	Factor	Remark	Pol/Phase
	MHz	dBuV/m	dBuV	dBuV/m	dB	dB/m		
1	10418.000	54.63	46.26	74.00	-19.37	8.37	Peak	Vertical
2	10418.000	45.28	36.91	54.00	-8.72	8.37	Average	Vertical
3	PK15630.000	60.16	43.89	74.00	-13.84	16.27	Peak	Vertical
4	PP15630.000	49.43	33.16	54.00	-4.57	16.27	Average	Vertical

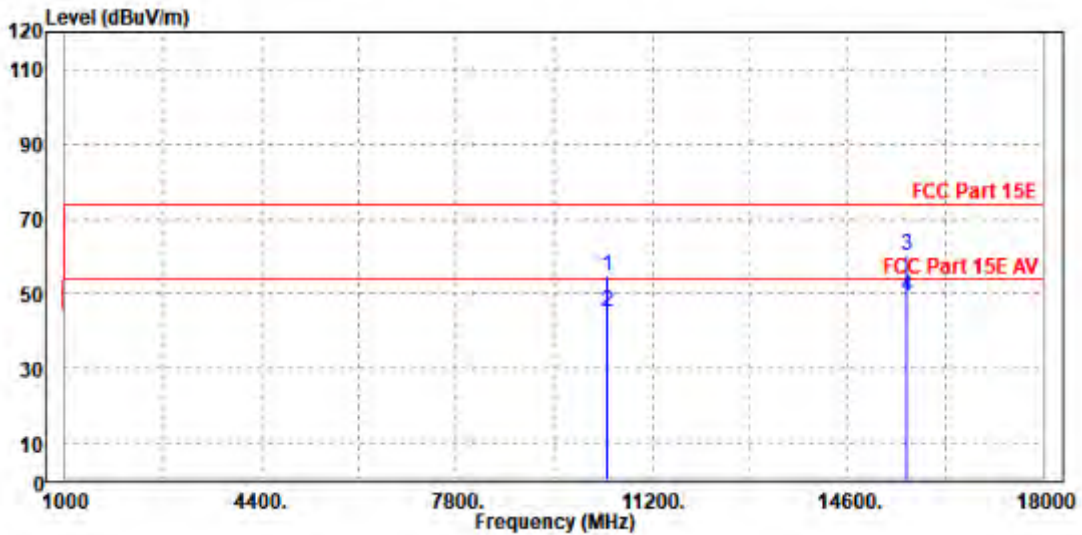



ANTENNA POLARITY & TEST DISTANCE: VERTICAL AT 3 M

	Freq	Level	Read Level	Limit Line	Over Limit	Factor	Remark	Pol/Phase
	MHz	dBuV/m	dBuV	dBuV/m	dB	dB/m		
1	10420.000	53.76	45.60	74.00	-20.24	8.16	Peak	Horizontal
2	10420.000	45.30	37.14	54.00	-8.70	8.16	Average	Horizontal
3	PK15637.000	60.98	44.92	74.00	-13.02	16.06	Peak	Horizontal
4	PP15637.000	48.90	32.84	54.00	-5.10	16.06	Average	Horizontal

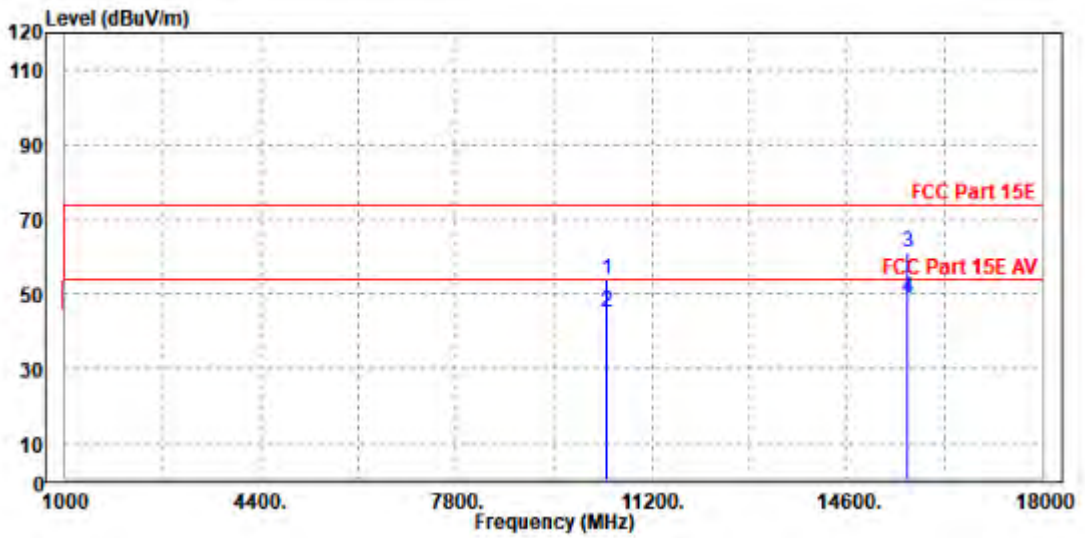

REMARKS:

1. Emission Level = Read Level+ Antenna Factor + Cable Loss- Preamp Factor
Margin value = Emission level – Limit value.
2. 5210MHz: Fundamental frequency.
3. For frequency above 18GHz, the emission was tested 20db below the limit so the data not recorded in the sheet.



5G WIFI-RU

802.11ax (20MHz) (RU26):

CHANNEL	TX Channel 36	DETECTOR FUNCTION	Peak (PK)
FREQUENCY RANGE	1GHz ~ 40GHz		Average (AV)

ANTENNA POLARITY & TEST DISTANCE: HORIZONTAL AT 3 M										
FREQ. (MHz)	EMISSION LEVEL (dBuV/m)	READ LEVEL (dBuV)	LIMIT (dBuV/m)	MARGIN (dB)	ANTENNA FACTOR (dB /m)	CABLE LOSS (dB)	PREAMP FACTOR (dB)	ANTENNA HEIGHT (cm)	TABLE ANGLE (Degree)	REMARK
5150	52.92	54.01	74	-21.08	34.26	11.17	46.52	100	25	Peak
5150	47.35	48.44	54	-6.65	34.26	11.17	46.52	100	25	Average
5180	103.85	104.91	/	/	34.27	11.2	46.53	100	25	Peak
5180	96.02	97.08	/	/	34.27	11.2	46.53	100	25	Average
5350	53.96	54.81	74	-20.04	34.34	11.39	46.58	100	25	Peak
5350	46.88	47.73	54	-7.12	34.34	11.39	46.58	100	25	Average
ANTENNA POLARITY & TEST DISTANCE: VERTICAL AT 3 M										
FREQ. (MHz)	EMISSION LEVEL (dBuV/m)	READ LEVEL (dBuV)	LIMIT (dBuV/m)	MARGIN (dB)	ANTENNA FACTOR (dB /m)	CABLE LOSS (dB)	PREAMP FACTOR (dB)	ANTENNA HEIGHT (cm)	TABLE ANGLE (Degree)	REMARK
5150	53.41	54.34	74	-20.59	34.42	11.17	46.52	100	305	Peak
5150	47.81	48.74	54	-6.19	34.42	11.17	46.52	100	305	Average
5180	113.18	114.07	/	/	34.44	11.2	46.53	100	305	Peak
5180	105.17	106.06	/	/	34.44	11.2	46.53	100	305	Average
5350	52.65	53.26	74	-21.35	34.58	11.39	46.58	100	305	Peak
5350	47.52	48.13	54	-6.48	34.58	11.39	46.58	100	305	Average

REMARKS:

- Emission Level = Read Level+ Antenna Factor + Cable Loss- Preamp Factor
Margin value = Emission level – Limit value.
- 5180MHz: Fundamental frequency.



CHANNEL	TX Channel 40	DETECTOR FUNCTION	Peak (PK)
FREQUENCY RANGE	1GHz ~ 40GHz		Average (AV)

ANTENNA POLARITY & TEST DISTANCE: HORIZONTAL AT 3 M

FREQ. (MHz)	EMISSION LEVEL (dBuV/m)	READ LEVEL (dBuV)	LIMIT (dBuV/m)	MARGIN (dB)	ANTENNA FACTOR (dB /m)	CABLE LOSS (dB)	PREAMP FACTOR (dB)	ANTENNA HEIGHT (cm)	TABLE ANGLE (Degree)	REMARK
5150	53.69	54.78	74	-20.31	34.26	11.17	46.52	100	310	Peak
5150	47.27	48.36	54	-6.73	34.26	11.17	46.52	100	310	Average
5200	103.45	104.49	/	/	34.28	11.22	46.54	100	310	Peak
5200	95.56	96.6	/	/	34.28	11.22	46.54	100	310	Average
5350	54.68	55.53	74	-19.32	34.34	11.39	46.58	100	310	Peak
5350	47.54	48.39	54	-6.46	34.34	11.39	46.58	100	310	Average

ANTENNA POLARITY & TEST DISTANCE: VERTICAL AT 3 M

FREQ. (MHz)	EMISSION LEVEL (dBuV/m)	READ LEVEL (dBuV)	LIMIT (dBuV/m)	MARGIN (dB)	ANTENNA FACTOR (dB /m)	CABLE LOSS (dB)	PREAMP FACTOR (dB)	ANTENNA HEIGHT (cm)	TABLE ANGLE (Degree)	REMARK
5150	52.63	53.56	74	-21.37	34.42	11.17	46.52	100	238	Peak
5150	48.2	49.13	54	-5.8	34.42	11.17	46.52	100	238	Average
5200	111.23	112.09	/	/	34.46	11.22	46.54	100	238	Peak
5200	104	104.86	/	/	34.46	11.22	46.54	100	238	Average
5350	52.91	53.52	74	-21.09	34.58	11.39	46.58	100	238	Peak
5350	48.42	49.03	54	-5.58	34.58	11.39	46.58	100	238	Average

REMARKS:

- Emission Level = Read Level+ Antenna Factor + Cable Loss- Preamp Factor
Margin value = Emission level – Limit value.
- 5200MHz: Fundamental frequency.



CHANNEL	TX Channel 48	DETECTOR FUNCTION	Peak (PK)
FREQUENCY RANGE	1GHz ~ 40GHz		Average (AV)

ANTENNA POLARITY & TEST DISTANCE: HORIZONTAL AT 3 M										
FREQ. (MHz)	EMISSION LEVEL (dBuV/m)	READ LEVEL (dBuV)	LIMIT (dBuV/m)	MARGIN (dB)	ANTENNA FACTOR (dB /m)	CABLE LOSS (dB)	PREAMP FACTOR (dB)	ANTENNA HEIGHT (cm)	TABLE ANGLE (Degree)	REMARK
5150	51.54	52.63	74	-22.46	34.26	11.17	46.52	100	315	Peak
5150	46.59	47.68	54	-7.41	34.26	11.17	46.52	100	315	Average
5240	103.53	104.51	/	/	34.3	11.27	46.55	100	315	Peak
5240	95.25	96.23	/	/	34.3	11.27	46.55	100	315	Average
5350	52.99	53.84	74	-21.01	34.34	11.39	46.58	100	315	Peak
5350	47.18	48.03	54	-6.82	34.34	11.39	46.58	100	315	Average

ANTENNA POLARITY & TEST DISTANCE: VERTICAL AT 3 M										
FREQ. (MHz)	EMISSION LEVEL (dBuV/m)	READ LEVEL (dBuV)	LIMIT (dBuV/m)	MARGIN (dB)	ANTENNA FACTOR (dB /m)	CABLE LOSS (dB)	PREAMP FACTOR (dB)	ANTENNA HEIGHT (cm)	TABLE ANGLE (Degree)	REMARK
5150	54.6	55.53	74	-19.4	34.42	11.17	46.52	100	238	Peak
5150	47.1	48.03	54	-6.9	34.42	11.17	46.52	100	238	Average
5240	111.52	112.31	/	/	34.49	11.27	46.55	100	238	Peak
5240	103.57	104.36	/	/	34.49	11.27	46.55	100	238	Average
5350	54.9	55.51	74	-19.1	34.58	11.39	46.58	100	238	Peak
5350	48.28	48.89	54	-5.72	34.58	11.39	46.58	100	238	Average

REMARKS:

- Emission Level = Read Level+ Antenna Factor + Cable Loss- Preamp Factor
Margin value = Emission level – Limit value.
- 5240MHz: Fundamental frequency.



802.11ax (20MHz) (RU52):

CHANNEL	TX Channel 36	DETECTOR FUNCTION	Peak (PK)
FREQUENCY RANGE	1GHz ~ 40GHz		Average (AV)

ANTENNA POLARITY & TEST DISTANCE: HORIZONTAL AT 3 M										
FREQ. (MHz)	EMISSION LEVEL (dBuV/m)	READ LEVEL (dBuV)	LIMIT (dBuV/m)	MARGIN (dB)	ANTENNA FACTOR (dB /m)	CABLE LOSS (dB)	PREAMP FACTOR (dB)	ANTENNA HEIGHT (cm)	TABLE ANGLE (Degree)	REMARK
5150	52.14	53.23	74	-21.86	34.26	11.17	46.52	100	25	Peak
5150	47.09	48.18	54	-6.91	34.26	11.17	46.52	100	25	Average
5180	102.72	103.78	/	/	34.27	11.2	46.53	100	25	Peak
5180	93.79	94.85	/	/	34.27	11.2	46.53	100	25	Average
5350	53.38	54.23	74	-20.62	34.34	11.39	46.58	100	25	Peak
5350	47.01	47.86	54	-6.99	34.34	11.39	46.58	100	25	Average

ANTENNA POLARITY & TEST DISTANCE: VERTICAL AT 3 M										
FREQ. (MHz)	EMISSION LEVEL (dBuV/m)	READ LEVEL (dBuV)	LIMIT (dBuV/m)	MARGIN (dB)	ANTENNA FACTOR (dB /m)	CABLE LOSS (dB)	PREAMP FACTOR (dB)	ANTENNA HEIGHT (cm)	TABLE ANGLE (Degree)	REMARK
5150	53.96	54.89	74	-20.04	34.42	11.17	46.52	100	305	Peak
5150	48.36	49.29	54	-5.64	34.42	11.17	46.52	100	305	Average
5180	110.9	111.79	/	/	34.44	11.2	46.53	100	305	Peak
5180	103.26	104.15	/	/	34.44	11.2	46.53	100	305	Average
5350	52.59	53.2	74	-21.41	34.58	11.39	46.58	100	305	Peak
5350	47.31	47.92	54	-6.69	34.58	11.39	46.58	100	305	Average

REMARKS:

- Emission Level = Read Level+ Antenna Factor + Cable Loss- Preamp Factor
Margin value = Emission level – Limit value.
- 5180MHz: Fundamental frequency.



CHANNEL	TX Channel 40	DETECTOR FUNCTION	Peak (PK)
FREQUENCY RANGE	1GHz ~ 40GHz		Average (AV)

ANTENNA POLARITY & TEST DISTANCE: HORIZONTAL AT 3 M										
FREQ. (MHz)	EMISSION LEVEL (dBuV/m)	READ LEVEL (dBuV)	LIMIT (dBuV/m)	MARGIN (dB)	ANTENNA FACTOR (dB /m)	CABLE LOSS (dB)	PREAMP FACTOR (dB)	ANTENNA HEIGHT (cm)	TABLE ANGLE (Degree)	REMARK
5150	53.93	55.02	74	-20.07	34.26	11.17	46.52	100	340	Peak
5150	48.39	49.48	54	-5.61	34.26	11.17	46.52	100	340	Average
5200	103.2	104.24	/	/	34.28	11.22	46.54	100	340	Peak
5200	94.59	95.63	/	/	34.28	11.22	46.54	100	340	Average
5350	53.33	54.18	74	-20.67	34.34	11.39	46.58	100	340	Peak
5350	46.92	47.77	54	-7.08	34.34	11.39	46.58	100	340	Average

ANTENNA POLARITY & TEST DISTANCE: VERTICAL AT 3 M										
FREQ. (MHz)	EMISSION LEVEL (dBuV/m)	READ LEVEL (dBuV)	LIMIT (dBuV/m)	MARGIN (dB)	ANTENNA FACTOR (dB /m)	CABLE LOSS (dB)	PREAMP FACTOR (dB)	ANTENNA HEIGHT (cm)	TABLE ANGLE (Degree)	REMARK
5150	53.72	54.65	74	-20.28	34.42	11.17	46.52	100	245	Peak
5150	47.55	48.48	54	-6.45	34.42	11.17	46.52	100	245	Average
5200	109.93	110.79	/	/	34.46	11.22	46.54	100	245	Peak
5200	100.37	101.23	/	/	34.46	11.22	46.54	100	245	Average
5350	53.75	54.36	74	-20.25	34.58	11.39	46.58	100	245	Peak
5350	47.13	47.74	54	-6.87	34.58	11.39	46.58	100	245	Average

REMARKS:

1. Emission Level = Read Level+ Antenna Factor + Cable Loss- Preamp Factor
Margin value = Emission level – Limit value.
2. 5200MHz: Fundamental frequency.



CHANNEL	TX Channel 48	DETECTOR FUNCTION	Peak (PK)
FREQUENCY RANGE	1GHz ~ 40GHz		Average (AV)

ANTENNA POLARITY & TEST DISTANCE: HORIZONTAL AT 3 M

FREQ. (MHz)	EMISSION LEVEL (dBuV/m)	READ LEVEL (dBuV)	LIMIT (dBuV/m)	MARGIN (dB)	ANTENNA FACTOR (dB /m)	CABLE LOSS (dB)	PREAMP FACTOR (dB)	ANTENNA HEIGHT (cm)	TABLE ANGLE (Degree)	REMARK
5150	51.68	52.77	74	-22.32	34.26	11.17	46.52	100	25	Peak
5150	47.71	48.8	54	-6.29	34.26	11.17	46.52	100	25	Average
5240	101.35	102.33	/	/	34.3	11.27	46.55	100	25	Peak
5240	92.62	93.6	/	/	34.3	11.27	46.55	100	25	Average
5350	51.36	52.21	74	-22.64	34.34	11.39	46.58	100	25	Peak
5350	46.91	47.76	54	-7.09	34.34	11.39	46.58	100	25	Average

ANTENNA POLARITY & TEST DISTANCE: VERTICAL AT 3 M

FREQ. (MHz)	EMISSION LEVEL (dBuV/m)	READ LEVEL (dBuV)	LIMIT (dBuV/m)	MARGIN (dB)	ANTENNA FACTOR (dB /m)	CABLE LOSS (dB)	PREAMP FACTOR (dB)	ANTENNA HEIGHT (cm)	TABLE ANGLE (Degree)	REMARK
5150	52.7	53.63	74	-21.3	34.42	11.17	46.52	100	260	Peak
5150	46.64	47.57	54	-7.36	34.42	11.17	46.52	100	260	Average
5240	110.46	111.25	/	/	34.49	11.27	46.55	100	260	Peak
5240	101.16	101.95	/	/	34.49	11.27	46.55	100	260	Average
5350	52.25	52.86	74	-21.75	34.58	11.39	46.58	100	260	Peak
5350	47.35	47.96	54	-6.65	34.58	11.39	46.58	100	260	Average

REMARKS:

- Emission Level = Read Level+ Antenna Factor + Cable Loss- Preamp Factor
Margin value = Emission level – Limit value.
- 5240MHz: Fundamental frequency.



802.11ax (20MHz) (RU106):

CHANNEL	TX Channel 36	DETECTOR FUNCTION	Peak (PK)
FREQUENCY RANGE	1GHz ~ 40GHz		Average (AV)

ANTENNA POLARITY & TEST DISTANCE: HORIZONTAL AT 3 M										
FREQ. (MHz)	EMISSION LEVEL (dBuV/m)	READ LEVEL (dBuV)	LIMIT (dBuV/m)	MARGIN (dB)	ANTENNA FACTOR (dB /m)	CABLE LOSS (dB)	PREAMP FACTOR (dB)	ANTENNA HEIGHT (cm)	TABLE ANGLE (Degree)	REMARK
5150	52.53	53.62	74	-21.47	34.26	11.17	46.52	100	340	Peak
5150	46.92	48.01	54	-7.08	34.26	11.17	46.52	100	340	Average
5180	101.85	102.91	/	/	34.27	11.2	46.53	100	340	Peak
5180	92.61	93.67	/	/	34.27	11.2	46.53	100	340	Average
5350	51.61	52.46	74	-22.39	34.34	11.39	46.58	100	340	Peak
5350	46.69	47.54	54	-7.31	34.34	11.39	46.58	100	340	Average

ANTENNA POLARITY & TEST DISTANCE: VERTICAL AT 3 M										
FREQ. (MHz)	EMISSION LEVEL (dBuV/m)	READ LEVEL (dBuV)	LIMIT (dBuV/m)	MARGIN (dB)	ANTENNA FACTOR (dB /m)	CABLE LOSS (dB)	PREAMP FACTOR (dB)	ANTENNA HEIGHT (cm)	TABLE ANGLE (Degree)	REMARK
5150	52.27	53.2	74	-21.73	34.42	11.17	46.52	100	245	Peak
5150	47.44	48.37	54	-6.56	34.42	11.17	46.52	100	245	Average
5180	106.5	107.39	/	/	34.44	11.2	46.53	100	245	Peak
5180	98.05	98.94	/	/	34.44	11.2	46.53	100	245	Average
5350	52.92	53.53	74	-21.08	34.58	11.39	46.58	100	245	Peak
5350	47.42	48.03	54	-6.58	34.58	11.39	46.58	100	245	Average

REMARKS:

- Emission Level = Read Level+ Antenna Factor + Cable Loss- Preamp Factor
Margin value = Emission level – Limit value.
- 5180MHz: Fundamental frequency.



CHANNEL	TX Channel 40	DETECTOR FUNCTION	Peak (PK)
FREQUENCY RANGE	1GHz ~ 40GHz		Average (AV)

ANTENNA POLARITY & TEST DISTANCE: HORIZONTAL AT 3 M										
FREQ. (MHz)	EMISSION LEVEL (dBuV/m)	READ LEVEL (dBuV)	LIMIT (dBuV/m)	MARGIN (dB)	ANTENNA FACTOR (dB /m)	CABLE LOSS (dB)	PREAMP FACTOR (dB)	ANTENNA HEIGHT (cm)	TABLE ANGLE (Degree)	REMARK
5150	53.04	54.13	74	-20.96	34.26	11.17	46.52	100	335	Peak
5150	46.94	48.03	54	-7.06	34.26	11.17	46.52	100	335	Average
5200	99.67	100.71	/	/	34.28	11.22	46.54	100	335	Peak
5200	90.38	91.42	/	/	34.28	11.22	46.54	100	335	Average
5350	52.76	53.61	74	-21.24	34.34	11.39	46.58	100	335	Peak
5350	46.78	47.63	54	-7.22	34.34	11.39	46.58	100	335	Average

ANTENNA POLARITY & TEST DISTANCE: VERTICAL AT 3 M										
FREQ. (MHz)	EMISSION LEVEL (dBuV/m)	READ LEVEL (dBuV)	LIMIT (dBuV/m)	MARGIN (dB)	ANTENNA FACTOR (dB /m)	CABLE LOSS (dB)	PREAMP FACTOR (dB)	ANTENNA HEIGHT (cm)	TABLE ANGLE (Degree)	REMARK
5150	51.69	52.62	74	-22.31	34.42	11.17	46.52	100	305	Peak
5150	47.68	48.61	54	-6.32	34.42	11.17	46.52	100	305	Average
5200	107.88	108.74	/	/	34.46	11.22	46.54	100	305	Peak
5200	98.86	99.72	/	/	34.46	11.22	46.54	100	305	Average
5350	53.01	53.62	74	-20.99	34.58	11.39	46.58	100	305	Peak
5350	47.77	48.38	54	-6.23	34.58	11.39	46.58	100	305	Average

REMARKS:

1. Emission Level = Read Level+ Antenna Factor + Cable Loss- Preamp Factor
Margin value = Emission level – Limit value.
2. 5200MHz: Fundamental frequency.



CHANNEL	TX Channel 48	DETECTOR FUNCTION	Peak (PK)
FREQUENCY RANGE	1GHz ~ 40GHz		Average (AV)

ANTENNA POLARITY & TEST DISTANCE: HORIZONTAL AT 3 M

FREQ. (MHz)	EMISSION LEVEL (dBuV/m)	READ LEVEL (dBuV)	LIMIT (dBuV/m)	MARGIN (dB)	ANTENNA FACTOR (dB /m)	CABLE LOSS (dB)	PREAMP FACTOR (dB)	ANTENNA HEIGHT (cm)	TABLE ANGLE (Degree)	REMARK
5150	52.13	53.22	74	-21.87	34.26	11.17	46.52	100	0	Peak
5150	46.17	47.26	54	-7.83	34.26	11.17	46.52	100	0	Average
5240	99.27	100.25	/	/	34.3	11.27	46.55	100	0	Peak
5240	90.28	91.26	/	/	34.3	11.27	46.55	100	0	Average
5350	53.9	54.75	74	-20.1	34.34	11.39	46.58	100	0	Peak
5350	47.25	48.1	54	-6.75	34.34	11.39	46.58	100	0	Average

ANTENNA POLARITY & TEST DISTANCE: VERTICAL AT 3 M

FREQ. (MHz)	EMISSION LEVEL (dBuV/m)	READ LEVEL (dBuV)	LIMIT (dBuV/m)	MARGIN (dB)	ANTENNA FACTOR (dB /m)	CABLE LOSS (dB)	PREAMP FACTOR (dB)	ANTENNA HEIGHT (cm)	TABLE ANGLE (Degree)	REMARK
5150	53.8	54.73	74	-20.2	34.42	11.17	46.52	100	305	Peak
5150	46.42	47.35	54	-7.58	34.42	11.17	46.52	100	305	Average
5240	109.74	110.53	/	/	34.49	11.27	46.55	100	305	Peak
5240	100.57	101.36	/	/	34.49	11.27	46.55	100	305	Average
5350	55.67	56.28	74	-18.33	34.58	11.39	46.58	100	305	Peak
5350	46.97	47.58	54	-7.03	34.58	11.39	46.58	100	305	Average

REMARKS:

- Emission Level = Read Level+ Antenna Factor + Cable Loss- Preamp Factor
Margin value = Emission level – Limit value.
- 5240MHz: Fundamental frequency.