



n48 (SCS 30 kHz) (Ant5)							
BW	MCS Index	RB Size	RB Offset	Low	Mid	High	
		Channel		640000	641666	643332	
		Frequency (MHz)		3600	3624.99	3649.98	
100M	DFT-s-OFDM Pi/2 BPSK	1	1	22.15	22.18	22.13	
		1	137	22.57	22.54	22.35	
		1	271	22.30	22.22	22.25	
		135	0	21.80	21.90	21.68	
		135	69	22.45	22.57	22.50	
		135	138	22.04	21.99	21.85	
		270	0	21.90	21.78	21.83	
	DFT-s-OFDM QPSK	1	1	22.21	22.11	22.16	
		1	137	22.58	22.53	22.38	
		1	271	22.51	22.39	22.39	
		135	0	21.97	21.92	21.82	
		135	69	22.62	22.48	22.55	
		135	138	21.96	21.99	21.93	
	DFT-s-OFDM 16QAM	1	137	22.16	22.18	22.11	
		DFT-s-OFDM 64QAM	1	137	20.78	20.69	20.68
			DFT-s-OFDM 256QAM	1	137	18.70	18.58
	BW	MCS Index		Channel		639668	641666
			Frequency (MHz)		3595.02	3624.99	3654.99
90M	DFT-s-OFDM QPSK	120	63	22.52	22.45	22.36	
BW	MCS Index	Channel		639334	641666	644000	
		Frequency (MHz)		3590.01	3624.99	3660	
80M	DFT-s-OFDM QPSK	108	55	22.56	22.47	22.36	
BW	MCS Index	Channel		639000	641666	644332	
		Frequency (MHz)		3585	3624.99	3664.98	
70M	DFT-s-OFDM QPSK	90	50	22.49	22.39	22.21	



BW	MCS Index	Channel		638668	641666	644666
		Frequency (MHz)		3580.02	3624.99	3669.99
60M	DFT-s-OFDM QPSK	81	41	22.47	22.50	22.35
BW	MCS Index	Channel		638334	641666	645000
		Frequency (MHz)		3575.01	3624.99	3675
50M	DFT-s-OFDM QPSK	64	35	22.49	22.51	22.29
BW	MCS Index	Channel		638000	641666	645332
		Frequency (MHz)		3570	3624.99	3679.98
40M	DFT-s-OFDM QPSK	50	28	22.55	22.48	22.36
BW	MCS Index	Channel		637668	641666	645666
		Frequency (MHz)		3565.02	3624.99	3684.99
30M	DFT-s-OFDM QPSK	36	21	22.59	22.53	22.48
BW	MCS Index	Channel		637334	641666	646000
		Frequency (MHz)		3560.01	3624.99	3690
20M	DFT-s-OFDM QPSK	25	13	22.56	22.48	22.32
BW	MCS Index	Channel		637168	641666	646166
		Frequency (MHz)		3557.52	3624.99	3692.49
15M	DFT-s-OFDM QPSK	18	10	22.55	22.48	22.22
BW	MCS Index	Channel		637000	641666	646332
		Frequency (MHz)		3555	3624.99	3694.98
10M	DFT-s-OFDM QPSK	12	6	22.65	22.51	22.40



n48 (SCS 30 kHz) (Ant7)						
BW	MCS Index	RB Size	RB Offset	Low	Mid	High
		Channel		640000	641666	643332
		Frequency (MHz)		3600	3624.99	3649.98
100M	DFT-s-OFDM Pi/2 BPSK	1	1	20.79	20.70	20.72
		1	137	21.16	21.23	20.90
		1	271	20.88	20.86	20.57
		135	0	20.15	20.05	19.97
		135	69	21.23	21.11	21.26
		135	138	20.27	20.08	20.12
		270	0	20.10	20.07	20.14
	DFT-s-OFDM QPSK	1	1	20.63	20.58	20.65
		1	137	21.27	21.21	21.04
		1	271	20.79	20.60	20.64
		135	0	20.16	20.09	19.92
		135	69	21.38	21.30	21.23
		135	138	20.37	20.32	20.23
		270	0	20.19	20.17	20.11
	DFT-s-OFDM 16QAM	135	69	20.49	20.31	20.45
	DFT-s-OFDM 64QAM	135	69	19.27	19.23	19.19
	DFT-s-OFDM 256QAM	135	69	17.46	17.19	17.18
	BW	MCS Index	Channel		639668	641666
Frequency (MHz)			3595.02	3624.99	3654.99	
90M	DFT-s-OFDM QPSK	120	63	21.07	21.16	20.79
BW	MCS Index	Channel		639334	641666	644000
		Frequency (MHz)		3590.01	3624.99	3660
80M	DFT-s-OFDM QPSK	108	55	21.05	21.00	21.19
BW	MCS Index	Channel		639000	641666	644332
		Frequency (MHz)		3585	3624.99	3664.98
70M	DFT-s-OFDM QPSK	90	50	21.21	21.11	20.89



BW	MCS Index	Channel		638668	641666	644666
		Frequency (MHz)		3580.02	3624.99	3669.99
60M	DFT-s-OFDM QPSK	81	41	21.08	21.16	20.85
BW	MCS Index	Channel		638334	641666	645000
		Frequency (MHz)		3575.01	3624.99	3675
50M	DFT-s-OFDM QPSK	64	35	21.22	21.09	21.21
BW	MCS Index	Channel		638000	641666	645332
		Frequency (MHz)		3570	3624.99	3679.98
40M	DFT-s-OFDM QPSK	50	28	21.16	21.12	20.95
BW	MCS Index	Channel		637668	641666	645666
		Frequency (MHz)		3565.02	3624.99	3684.99
30M	DFT-s-OFDM QPSK	36	21	21.25	21.28	21.09
BW	MCS Index	Channel		637334	641666	646000
		Frequency (MHz)		3560.01	3624.99	3690
20M	DFT-s-OFDM QPSK	25	13	21.14	21.15	20.96
BW	MCS Index	Channel		637168	641666	646166
		Frequency (MHz)		3557.52	3624.99	3692.49
15M	DFT-s-OFDM QPSK	18	10	21.26	21.18	21.09
BW	MCS Index	Channel		637000	641666	646332
		Frequency (MHz)		3555	3624.99	3694.98
10M	DFT-s-OFDM QPSK	12	6	21.01	21.22	20.85



EIRP

Normal:

ANT 2(UP):

n48 100M DFT-s-OFDM Pi/2 BPSK(SCS 30 kHz)						
Channel	Frequency (MHz)	Conducted Power (dBm)	Gain (dB)	EIRP (dBm)	EIRP (mW)	Lmit (dBm/10Mhz)
640000	3600	21.05	-2	19.05	80.35	23
641666	3624.99	20.82	-2	18.82	76.21	23
643332	3649.98	20.68	-2	18.68	73.79	23

n48 100M DFT-s-OFDM QPSK(SCS 30 kHz)						
Channel	Frequency (MHz)	Conducted Power (dBm)	Gain (dB)	EIRP (dBm)	EIRP (mW)	Lmit (dBm/10Mhz)
640000	3600	21.15	-2	19.15	82.22	23
641666	3624.99	20.89	-2	18.89	77.45	23
643332	3649.98	20.73	-2	18.73	74.64	23

n48 100M DFT-s-OFDM 16QAM(SCS 30 kHz)						
Channel	Frequency (MHz)	Conducted Power (dBm)	Gain (dB)	EIRP (dBm)	EIRP (mW)	Lmit (dBm/10Mhz)
640000	3600	20.14	-2	18.14	65.16	23
641666	3624.99	20.08	-2	18.08	64.27	23
643332	3649.98	19.87	-2	17.87	61.24	23

n48 100M DFT-s-OFDM 64QAM(SCS 30 kHz)						
Channel	Frequency (MHz)	Conducted Power (dBm)	Gain (dB)	EIRP (dBm)	EIRP (mW)	Lmit (dBm/10Mhz)
640000	3600	18.79	-2	16.79	47.75	23
641666	3624.99	18.7	-2	16.7	46.77	23
643332	3649.98	18.73	-2	16.73	47.1	23

n48 100M DFT-s-OFDM 256QAM(SCS 30 kHz)						
Channel	Frequency (MHz)	Conducted Power (dBm)	Gain (dB)	EIRP (dBm)	EIRP (mW)	Lmit (dBm/10Mhz)
640000	3600	16.91	-2	14.91	30.97	23
641666	3624.99	16.85	-2	14.85	30.55	23
643332	3649.98	16.7	-2	14.7	29.51	23



n48 90M DFT-s-OFDM QPSK(SCS 30 kHz)						
Channel	Frequency (MHz)	Conducted Power (dBm)	Gain (dB)	EIRP (dBm)	EIRP (mW)	Lmit (dBm/10Mhz)
639668	3595.02	20.91	-2	18.91	77.8	23
641666	3624.99	20.67	-2	18.67	73.62	23
643666	3654.99	20.52	-2	18.52	71.12	23

n48 80M DFT-s-OFDM QPSK(SCS 30 kHz)						
Channel	Frequency (MHz)	Conducted Power (dBm)	Gain (dB)	EIRP (dBm)	EIRP (mW)	Lmit (dBm/10Mhz)
639334	3590.01	20.85	-2	18.85	76.74	23
641666	3624.99	20.72	-2	18.72	74.47	23
644000	3660	20.59	-2	18.59	72.28	23

n48 70M DFT-s-OFDM QPSK(SCS 30 kHz)						
Channel	Frequency (MHz)	Conducted Power (dBm)	Gain (dB)	EIRP (dBm)	EIRP (mW)	Lmit (dBm/10Mhz)
639000	3585	20.88	-2	18.88	77.27	23
641666	3624.99	20.63	-2	18.63	72.95	23
644332	3664.98	20.44	-2	18.44	69.82	23

n48 60M DFT-s-OFDM QPSK(SCS 30 kHz)						
Channel	Frequency (MHz)	Conducted Power (dBm)	Gain (dB)	EIRP (dBm)	EIRP (mW)	Lmit (dBm/10Mhz)
638668	3580.02	21.12	-2	19.12	81.66	23
641666	3624.99	20.75	-2	18.75	74.99	23
644666	3669.99	20.7	-2	18.7	74.13	23

n48 50M DFT-s-OFDM QPSK(SCS 30 kHz)						
Channel	Frequency (MHz)	Conducted Power (dBm)	Gain (dB)	EIRP (dBm)	EIRP (mW)	Lmit (dBm/10Mhz)
638334	3575.01	21.02	-2	19.02	79.8	23
641666	3624.99	20.79	-2	18.79	75.68	23
645000	3675	20.49	-2	18.49	70.63	23



n48 40M DFT-s-OFDM QPSK(SCS 30 kHz)						
Channel	Frequency (MHz)	Conducted Power (dBm)	Gain (dB)	EIRP (dBm)	EIRP (mW)	Lmit (dBm/10Mhz)
638000	3570	20.97	-2	18.97	78.89	23
641666	3624.99	20.77	-2	18.77	75.34	23
645332	3679.98	20.53	-2	18.53	71.29	23

n48 30M DFT-s-OFDM QPSK(SCS 30 kHz)						
Channel	Frequency (MHz)	Conducted Power (dBm)	Gain (dB)	EIRP (dBm)	EIRP (mW)	Lmit (dBm/10Mhz)
637668	3565.02	20.92	-2	18.92	77.98	23
641666	3624.99	20.73	-2	18.73	74.64	23
645666	3684.99	20.58	-2	18.58	72.11	23

n48 20M DFT-s-OFDM QPSK(SCS 30 kHz)						
Channel	Frequency (MHz)	Conducted Power (dBm)	Gain (dB)	EIRP (dBm)	EIRP (mW)	Lmit (dBm/10Mhz)
637334	3560.01	21.12	-2	19.12	81.66	23
641666	3624.99	20.75	-2	18.75	74.99	23
646000	3690	20.62	-2	18.62	72.78	23

n48 15M DFT-s-OFDM QPSK(SCS 30 kHz)						
Channel	Frequency (MHz)	Conducted Power (dBm)	Gain (dB)	EIRP (dBm)	EIRP (mW)	Lmit (dBm/10Mhz)
637168	3557.52	21	-2	19	79.43	23
641666	3624.99	20.7	-2	18.7	74.13	23
646166	3692.49	20.59	-2	18.59	72.28	23

n48 10M DFT-s-OFDM QPSK(SCS 30 kHz)						
Channel	Frequency (MHz)	Conducted Power (dBm)	Gain (dB)	EIRP (dBm)	EIRP (mW)	Lmit (dBm/10Mhz)
637000	3555	21.1	-2	19.1	81.28	23
641666	3624.99	20.85	-2	18.85	76.74	23
646332	3694.98	20.66	-2	18.66	73.45	23



ANT 3(UP):

n48 100M DFT-s-OFDM Pi/2 BPSK(SCS 30 kHz)						
Channel	Frequency (MHz)	Conducted Power (dBm)	Gain (dB)	EIRP (dBm)	EIRP (mW)	Lmit (dBm/10Mhz)
640000	3600	19.2	-5.7	13.5	22.39	23
641666	3624.99	19.4	-5.7	13.7	23.44	23
643332	3649.98	19.32	-5.7	13.62	23.01	23

n48 100M DFT-s-OFDM QPSK(SCS 30 kHz)						
Channel	Frequency (MHz)	Conducted Power (dBm)	Gain (dB)	EIRP (dBm)	EIRP (mW)	Lmit (dBm/10Mhz)
640000	3600	19.2	-5.7	13.5	22.39	23
641666	3624.99	19.25	-5.7	13.55	22.65	23
643332	3649.98	19.54	-5.7	13.84	24.21	23

n48 100M DFT-s-OFDM 16QAM(SCS 30 kHz)						
Channel	Frequency (MHz)	Conducted Power (dBm)	Gain (dB)	EIRP (dBm)	EIRP (mW)	Lmit (dBm/10Mhz)
640000	3600	18.25	-5.7	12.55	17.99	23
641666	3624.99	18.35	-5.7	12.65	18.41	23
643332	3649.98	18.43	-5.7	12.73	18.75	23

n48 100M DFT-s-OFDM 64QAM(SCS 30 kHz)						
Channel	Frequency (MHz)	Conducted Power (dBm)	Gain (dB)	EIRP (dBm)	EIRP (mW)	Lmit (dBm/10Mhz)
640000	3600	16.93	-5.7	11.23	13.27	23
641666	3624.99	16.99	-5.7	11.29	13.46	23
643332	3649.98	17.06	-5.7	11.36	13.68	23

n48 100M DFT-s-OFDM 256QAM(SCS 30 kHz)						
Channel	Frequency (MHz)	Conducted Power (dBm)	Gain (dB)	EIRP (dBm)	EIRP (mW)	Lmit (dBm/10Mhz)
640000	3600	14.98	-5.7	9.28	8.47	23
641666	3624.99	14.93	-5.7	9.23	8.38	23
643332	3649.98	14.98	-5.7	9.28	8.47	23



n48 90M DFT-s-OFDM QPSK(SCS 30 kHz)						
Channel	Frequency (MHz)	Conducted Power (dBm)	Gain (dB)	EIRP (dBm)	EIRP (mW)	Lmit (dBm/10Mhz)
639668	3595.02	19.18	-5.7	13.48	22.28	23
641666	3624.99	19.3	-5.7	13.6	22.91	23
643666	3654.99	19.15	-5.7	13.45	22.13	23

n48 80M DFT-s-OFDM QPSK(SCS 30 kHz)						
Channel	Frequency (MHz)	Conducted Power (dBm)	Gain (dB)	EIRP (dBm)	EIRP (mW)	Lmit (dBm/10Mhz)
639334	3590.01	19.07	-5.7	13.37	21.73	23
641666	3624.99	19.27	-5.7	13.57	22.75	23
644000	3660	19.23	-5.7	13.53	22.54	23

n48 70M DFT-s-OFDM QPSK(SCS 30 kHz)						
Channel	Frequency (MHz)	Conducted Power (dBm)	Gain (dB)	EIRP (dBm)	EIRP (mW)	Lmit (dBm/10Mhz)
639000	3585	19.12	-5.7	13.42	21.98	23
641666	3624.99	19.11	-5.7	13.41	21.93	23
644332	3664.98	19.13	-5.7	13.43	22.03	23

n48 60M DFT-s-OFDM QPSK(SCS 30 kHz)						
Channel	Frequency (MHz)	Conducted Power (dBm)	Gain (dB)	EIRP (dBm)	EIRP (mW)	Lmit (dBm/10Mhz)
638668	3580.02	19.07	-5.7	13.37	21.73	23
641666	3624.99	19.21	-5.7	13.51	22.44	23
644666	3669.99	19.15	-5.7	13.45	22.13	23

n48 50M DFT-s-OFDM QPSK(SCS 30 kHz)						
Channel	Frequency (MHz)	Conducted Power (dBm)	Gain (dB)	EIRP (dBm)	EIRP (mW)	Lmit (dBm/10Mhz)
638334	3575.01	19.15	-5.7	13.45	22.13	23
641666	3624.99	19.17	-5.7	13.47	22.23	23
645000	3675	19.22	-5.7	13.52	22.49	23



n48 40M DFT-s-OFDM QPSK(SCS 30 kHz)						
Channel	Frequency (MHz)	Conducted Power (dBm)	Gain (dB)	EIRP (dBm)	EIRP (mW)	Lmit (dBm/10Mhz)
638000	3570	19.19	-5.7	13.49	22.34	23
641666	3624.99	19.3	-5.7	13.6	22.91	23
645332	3679.98	19.31	-5.7	13.61	22.96	23

n48 30M DFT-s-OFDM QPSK(SCS 30 kHz)						
Channel	Frequency (MHz)	Conducted Power (dBm)	Gain (dB)	EIRP (dBm)	EIRP (mW)	Lmit (dBm/10Mhz)
637668	3565.02	19.1	-5.7	13.4	21.88	23
641666	3624.99	19.13	-5.7	13.43	22.03	23
645666	3684.99	19.19	-5.7	13.49	22.34	23

n48 20M DFT-s-OFDM QPSK(SCS 30 kHz)						
Channel	Frequency (MHz)	Conducted Power (dBm)	Gain (dB)	EIRP (dBm)	EIRP (mW)	Lmit (dBm/10Mhz)
637334	3560.01	19.05	-5.7	13.35	21.63	23
641666	3624.99	19.19	-5.7	13.49	22.34	23
646000	3690	19.07	-5.7	13.37	21.73	23

n48 15M DFT-s-OFDM QPSK(SCS 30 kHz)						
Channel	Frequency (MHz)	Conducted Power (dBm)	Gain (dB)	EIRP (dBm)	EIRP (mW)	Lmit (dBm/10Mhz)
637168	3557.52	19.18	-5.7	13.48	22.28	23
641666	3624.99	19.27	-5.7	13.57	22.75	23
646166	3692.49	19.24	-5.7	13.54	22.59	23

n48 10M DFT-s-OFDM QPSK(SCS 30 kHz)						
Channel	Frequency (MHz)	Conducted Power (dBm)	Gain (dB)	EIRP (dBm)	EIRP (mW)	Lmit (dBm/10Mhz)
637000	3555	19.22	-5.7	13.52	22.49	23
641666	3624.99	19.18	-5.7	13.48	22.28	23
646332	3694.98	19.09	-5.7	13.39	21.83	23



ANT 5(UP):

n48 100M DFT-s-OFDM Pi/2 BPSK(SCS 30 kHz)						
Channel	Frequency (MHz)	Conducted Power (dBm)	Gain (dB)	EIRP (dBm)	EIRP (mW)	Lmit (dBm/10Mhz)
640000	3600	22.57	-0.2	22.37	172.58	23
641666	3624.99	22.57	-0.2	22.37	172.58	23
643332	3649.98	22.5	-0.2	22.3	169.82	23

n48 100M DFT-s-OFDM QPSK(SCS 30 kHz)						
Channel	Frequency (MHz)	Conducted Power (dBm)	Gain (dB)	EIRP (dBm)	EIRP (mW)	Lmit (dBm/10Mhz)
640000	3600	22.62	-0.2	22.42	174.58	23
641666	3624.99	22.53	-0.2	22.33	171	23
643332	3649.98	22.55	-0.2	22.35	171.79	23

n48 100M DFT-s-OFDM 16QAM(SCS 30 kHz)						
Channel	Frequency (MHz)	Conducted Power (dBm)	Gain (dB)	EIRP (dBm)	EIRP (mW)	Lmit (dBm/10Mhz)
640000	3600	22.16	-0.2	21.96	157.04	23
641666	3624.99	22.18	-0.2	21.98	157.76	23
643332	3649.98	22.11	-0.2	21.91	155.24	23

n48 100M DFT-s-OFDM 64QAM(SCS 30 kHz)						
Channel	Frequency (MHz)	Conducted Power (dBm)	Gain (dB)	EIRP (dBm)	EIRP (mW)	Lmit (dBm/10Mhz)
640000	3600	20.78	-0.2	20.58	114.29	23
641666	3624.99	20.69	-0.2	20.49	111.94	23
643332	3649.98	20.68	-0.2	20.48	111.69	23

n48 100M DFT-s-OFDM 256QAM(SCS 30 kHz)						
Channel	Frequency (MHz)	Conducted Power (dBm)	Gain (dB)	EIRP (dBm)	EIRP (mW)	Lmit (dBm/10Mhz)
640000	3600	18.7	-0.2	18.5	70.79	23
641666	3624.99	18.58	-0.2	18.38	68.87	23
643332	3649.98	18.69	-0.2	18.49	70.63	23



n48 90M DFT-s-OFDM QPSK(SCS 30 kHz)						
Channel	Frequency (MHz)	Conducted Power (dBm)	Gain (dB)	EIRP (dBm)	EIRP (mW)	Lmit (dBm/10Mhz)
639668	3595.02	22.52	-0.2	22.32	170.61	23
641666	3624.99	22.45	-0.2	22.25	167.88	23
643666	3654.99	22.36	-0.2	22.16	164.44	23

n48 80M DFT-s-OFDM QPSK(SCS 30 kHz)						
Channel	Frequency (MHz)	Conducted Power (dBm)	Gain (dB)	EIRP (dBm)	EIRP (mW)	Lmit (dBm/10Mhz)
639334	3590.01	22.56	-0.2	22.36	172.19	23
641666	3624.99	22.47	-0.2	22.27	168.66	23
644000	3660	22.36	-0.2	22.16	164.44	23

n48 70M DFT-s-OFDM QPSK(SCS 30 kHz)						
Channel	Frequency (MHz)	Conducted Power (dBm)	Gain (dB)	EIRP (dBm)	EIRP (mW)	Lmit (dBm/10Mhz)
639000	3585	22.49	-0.2	22.29	169.43	23
641666	3624.99	22.39	-0.2	22.19	165.58	23
644332	3664.98	22.21	-0.2	22.01	158.85	23

n48 60M DFT-s-OFDM QPSK(SCS 30 kHz)						
Channel	Frequency (MHz)	Conducted Power (dBm)	Gain (dB)	EIRP (dBm)	EIRP (mW)	Lmit (dBm/10Mhz)
638668	3580.02	22.47	-0.2	22.27	168.66	23
641666	3624.99	22.5	-0.2	22.3	169.82	23
644666	3669.99	22.35	-0.2	22.15	164.06	23

n48 50M DFT-s-OFDM QPSK(SCS 30 kHz)						
Channel	Frequency (MHz)	Conducted Power (dBm)	Gain (dB)	EIRP (dBm)	EIRP (mW)	Lmit (dBm/10Mhz)
638334	3575.01	22.49	-0.2	22.29	169.43	23
641666	3624.99	22.51	-0.2	22.31	170.22	23
645000	3675	22.29	-0.2	22.09	161.81	23



n48 40M DFT-s-OFDM QPSK(SCS 30 kHz)						
Channel	Frequency (MHz)	Conducted Power (dBm)	Gain (dB)	EIRP (dBm)	EIRP (mW)	Lmit (dBm/10Mhz)
638000	3570	22.55	-0.2	22.35	171.79	23
641666	3624.99	22.48	-0.2	22.28	169.04	23
645332	3679.98	22.36	-0.2	22.16	164.44	23

n48 30M DFT-s-OFDM QPSK(SCS 30 kHz)						
Channel	Frequency (MHz)	Conducted Power (dBm)	Gain (dB)	EIRP (dBm)	EIRP (mW)	Lmit (dBm/10Mhz)
637668	3565.02	22.59	-0.2	22.39	173.38	23
641666	3624.99	22.53	-0.2	22.33	171	23
645666	3684.99	22.48	-0.2	22.28	169.04	23

n48 20M DFT-s-OFDM QPSK(SCS 30 kHz)						
Channel	Frequency (MHz)	Conducted Power (dBm)	Gain (dB)	EIRP (dBm)	EIRP (mW)	Lmit (dBm/10Mhz)
637334	3560.01	22.56	-0.2	22.36	172.19	23
641666	3624.99	22.48	-0.2	22.28	169.04	23
646000	3690	22.32	-0.2	22.12	162.93	23

n48 15M DFT-s-OFDM QPSK(SCS 30 kHz)						
Channel	Frequency (MHz)	Conducted Power (dBm)	Gain (dB)	EIRP (dBm)	EIRP (mW)	Lmit (dBm/10Mhz)
637168	3557.52	22.55	-0.2	22.35	171.79	23
641666	3624.99	22.48	-0.2	22.28	169.04	23
646166	3692.49	22.22	-0.2	22.02	159.22	23

n48 10M DFT-s-OFDM QPSK(SCS 30 kHz)						
Channel	Frequency (MHz)	Conducted Power (dBm)	Gain (dB)	EIRP (dBm)	EIRP (mW)	Lmit (dBm/10Mhz)
637000	3555	22.65	-0.2	22.45	175.79	23
641666	3624.99	22.51	-0.2	22.31	170.22	23
646332	3694.98	22.4	-0.2	22.2	165.96	23



ANT 7(UP):

n48 100M DFT-s-OFDM Pi/2 BPSK(SCS 30 kHz)						
Channel	Frequency (MHz)	Conducted Power (dBm)	Gain (dB)	EIRP (dBm)	EIRP (mW)	Lmit (dBm/10Mhz)
640000	3600	21.23	-0.1	21.13	129.72	23
641666	3624.99	21.23	-0.1	21.13	129.72	23
643332	3649.98	21.26	-0.1	21.16	130.62	23

n48 100M DFT-s-OFDM QPSK(SCS 30 kHz)						
Channel	Frequency (MHz)	Conducted Power (dBm)	Gain (dB)	EIRP (dBm)	EIRP (mW)	Lmit (dBm/10Mhz)
640000	3600	21.38	-0.1	21.28	134.28	23
641666	3624.99	21.3	-0.1	21.2	131.83	23
643332	3649.98	21.23	-0.1	21.13	129.72	23

n48 100M DFT-s-OFDM 16QAM(SCS 30 kHz)						
Channel	Frequency (MHz)	Conducted Power (dBm)	Gain (dB)	EIRP (dBm)	EIRP (mW)	Lmit (dBm/10Mhz)
640000	3600	20.49	-0.1	20.39	109.4	23
641666	3624.99	20.31	-0.1	20.21	104.95	23
643332	3649.98	20.45	-0.1	20.35	108.39	23

n48 100M DFT-s-OFDM 64QAM(SCS 30 kHz)						
Channel	Frequency (MHz)	Conducted Power (dBm)	Gain (dB)	EIRP (dBm)	EIRP (mW)	Lmit (dBm/10Mhz)
640000	3600	19.27	-0.1	19.17	82.6	23
641666	3624.99	19.23	-0.1	19.13	81.85	23
643332	3649.98	19.19	-0.1	19.09	81.1	23

n48 100M DFT-s-OFDM 256QAM(SCS 30 kHz)						
Channel	Frequency (MHz)	Conducted Power (dBm)	Gain (dB)	EIRP (dBm)	EIRP (mW)	Lmit (dBm/10Mhz)
640000	3600	17.46	-0.1	17.36	54.45	23
641666	3624.99	17.19	-0.1	17.09	51.17	23
643332	3649.98	17.18	-0.1	17.08	51.05	23



n48 90M DFT-s-OFDM QPSK(SCS 30 kHz)						
Channel	Frequency (MHz)	Conducted Power (dBm)	Gain (dB)	EIRP (dBm)	EIRP (mW)	Lmit (dBm/10Mhz)
639668	3595.02	21.07	-0.1	20.97	125.03	23
641666	3624.99	21.16	-0.1	21.06	127.64	23
643666	3654.99	20.79	-0.1	20.69	117.22	23

n48 80M DFT-s-OFDM QPSK(SCS 30 kHz)						
Channel	Frequency (MHz)	Conducted Power (dBm)	Gain (dB)	EIRP (dBm)	EIRP (mW)	Lmit (dBm/10Mhz)
639334	3590.01	21.05	-0.1	20.95	124.45	23
641666	3624.99	21	-0.1	20.9	123.03	23
644000	3660	21.19	-0.1	21.09	128.53	23

n48 70M DFT-s-OFDM QPSK(SCS 30 kHz)						
Channel	Frequency (MHz)	Conducted Power (dBm)	Gain (dB)	EIRP (dBm)	EIRP (mW)	Lmit (dBm/10Mhz)
639000	3585	21.21	-0.1	21.11	129.12	23
641666	3624.99	21.11	-0.1	21.01	126.18	23
644332	3664.98	20.89	-0.1	20.79	119.95	23

n48 60M DFT-s-OFDM QPSK(SCS 30 kHz)						
Channel	Frequency (MHz)	Conducted Power (dBm)	Gain (dB)	EIRP (dBm)	EIRP (mW)	Lmit (dBm/10Mhz)
638668	3580.02	21.08	-0.1	20.98	125.31	23
641666	3624.99	21.16	-0.1	21.06	127.64	23
644666	3669.99	20.85	-0.1	20.75	118.85	23

n48 50M DFT-s-OFDM QPSK(SCS 30 kHz)						
Channel	Frequency (MHz)	Conducted Power (dBm)	Gain (dB)	EIRP (dBm)	EIRP (mW)	Lmit (dBm/10Mhz)
638334	3575.01	21.22	-0.1	21.12	129.42	23
641666	3624.99	21.09	-0.1	20.99	125.6	23
645000	3675	21.21	-0.1	21.11	129.12	23



n48 40M DFT-s-OFDM QPSK(SCS 30 kHz)						
Channel	Frequency (MHz)	Conducted Power (dBm)	Gain (dB)	EIRP (dBm)	EIRP (mW)	Lmit (dBm/10Mhz)
638000	3570	21.16	-0.1	21.06	127.64	23
641666	3624.99	21.12	-0.1	21.02	126.47	23
645332	3679.98	20.95	-0.1	20.85	121.62	23

n48 30M DFT-s-OFDM QPSK(SCS 30 kHz)						
Channel	Frequency (MHz)	Conducted Power (dBm)	Gain (dB)	EIRP (dBm)	EIRP (mW)	Lmit (dBm/10Mhz)
637668	3565.02	21.25	-0.1	21.15	130.32	23
641666	3624.99	21.28	-0.1	21.18	131.22	23
645666	3684.99	21.09	-0.1	20.99	125.6	23

n48 20M DFT-s-OFDM QPSK(SCS 30 kHz)						
Channel	Frequency (MHz)	Conducted Power (dBm)	Gain (dB)	EIRP (dBm)	EIRP (mW)	Lmit (dBm/10Mhz)
637334	3560.01	21.14	-0.1	21.04	127.06	23
641666	3624.99	21.15	-0.1	21.05	127.35	23
646000	3690	20.96	-0.1	20.86	121.9	23

n48 15M DFT-s-OFDM QPSK(SCS 30 kHz)						
Channel	Frequency (MHz)	Conducted Power (dBm)	Gain (dB)	EIRP (dBm)	EIRP (mW)	Lmit (dBm/10Mhz)
637168	3557.52	21.26	-0.1	21.16	130.62	23
641666	3624.99	21.18	-0.1	21.08	128.23	23
646166	3692.49	21.09	-0.1	20.99	125.6	23

n48 10M DFT-s-OFDM QPSK(SCS 30 kHz)						
Channel	Frequency (MHz)	Conducted Power (dBm)	Gain (dB)	EIRP (dBm)	EIRP (mW)	Lmit (dBm/10Mhz)
637000	3555	21.01	-0.1	20.91	123.31	23
641666	3624.99	21.22	-0.1	21.12	129.42	23
646332	3694.98	20.85	-0.1	20.75	118.85	23



Changed:
ANT 2(UP):

n48 50M DFT-s-OFDM Pi/2 BPSK(SCS 15 kHz)						
Channel	Frequency (MHz)	Conducted Power (dBm)	Gain (dB)	EIRP (dBm)	EIRP (mW)	Lmit (dBm/10Mhz)
638334	3575.01	21.34	-2	19.34	85.9	23
641666	3624.99	20.99	-2	18.99	79.25	23
645000	3675	20.79	-2	18.79	75.68	23

n48 50M DFT-s-OFDM QPSK(SCS 15 kHz)						
Channel	Frequency (MHz)	Conducted Power (dBm)	Gain (dB)	EIRP (dBm)	EIRP (mW)	Lmit (dBm/10Mhz)
638334	3575.01	21.36	-2	19.36	86.3	23
641666	3624.99	21.11	-2	19.11	81.47	23
645000	3675	20.85	-2	18.85	76.74	23

n48 50M DFT-s-OFDM 16QAM(SCS 15 kHz)						
Channel	Frequency (MHz)	Conducted Power (dBm)	Gain (dB)	EIRP (dBm)	EIRP (mW)	Lmit (dBm/10Mhz)
638334	3575.01	20.63	-2	18.63	72.95	23
641666	3624.99	20.29	-2	18.29	67.45	23
645000	3675	20.06	-2	18.06	63.97	23

n48 50M DFT-s-OFDM 64QAM(SCS 15 kHz)						
Channel	Frequency (MHz)	Conducted Power (dBm)	Gain (dB)	EIRP (dBm)	EIRP (mW)	Lmit (dBm/10Mhz)
638334	3575.01	19.11	-2	17.11	51.4	23
641666	3624.99	18.8	-2	16.8	47.86	23
645000	3675	18.61	-2	16.61	45.81	23

n48 50M DFT-s-OFDM 256QAM(SCS 15 kHz)						
Channel	Frequency (MHz)	Conducted Power (dBm)	Gain (dB)	EIRP (dBm)	EIRP (mW)	Lmit (dBm/10Mhz)
638334	3575.01	17.18	-2	15.18	32.96	23
641666	3624.99	16.9	-2	14.9	30.9	23
645000	3675	16.57	-2	14.57	28.64	23



n48 40M DFT-s-OFDM QPSK(SCS 15 kHz)						
Channel	Frequency (MHz)	Conducted Power (dBm)	Gain (dB)	EIRP (dBm)	EIRP (mW)	Lmit (dBm/10Mhz)
638000	3570	21.22	-2	19.22	83.56	23
641666	3624.99	20.88	-2	18.88	77.27	23
645332	3679.98	20.77	-2	18.77	75.34	23

n48 20M DFT-s-OFDM QPSK(SCS 15 kHz)						
Channel	Frequency (MHz)	Conducted Power (dBm)	Gain (dB)	EIRP (dBm)	EIRP (mW)	Lmit (dBm/10Mhz)
637334	3560.01	20.97	-2	18.97	78.89	23
641666	3624.99	20.74	-2	18.74	74.82	23
646000	3690	20.81	-2	18.81	76.03	23

n48 15M DFT-s-OFDM QPSK(SCS 15 kHz)						
Channel	Frequency (MHz)	Conducted Power (dBm)	Gain (dB)	EIRP (dBm)	EIRP (mW)	Lmit (dBm/10Mhz)
637168	3557.52	21.2	-2	19.2	83.18	23
641666	3624.99	20.83	-2	18.83	76.38	23
646166	3692.49	20.7	-2	18.7	74.13	23

n48 10M DFT-s-OFDM QPSK(SCS 15 kHz)						
Channel	Frequency (MHz)	Conducted Power (dBm)	Gain (dB)	EIRP (dBm)	EIRP (mW)	Lmit (dBm/10Mhz)
637000	3555	21.17	-2	19.17	82.6	23
641666	3624.99	20.85	-2	18.85	76.74	23
646332	3694.98	20.72	-2	18.72	74.47	23



ANT 3(UP):

n48 50M DFT-s-OFDM Pi/2 BPSK(SCS 15 kHz)						
Channel	Frequency (MHz)	Conducted Power (dBm)	Gain (dB)	EIRP (dBm)	EIRP (mW)	Lmit (dBm/10Mhz)
638334	3575.01	19.03	-5.7	13.33	21.53	23
641666	3624.99	19.08	-5.7	13.38	21.78	23
645000	3675	19.28	-5.7	13.58	22.8	23

n48 50M DFT-s-OFDM QPSK(SCS 15 kHz)						
Channel	Frequency (MHz)	Conducted Power (dBm)	Gain (dB)	EIRP (dBm)	EIRP (mW)	Lmit (dBm/10Mhz)
638334	3575.01	19.09	-5.7	13.39	21.83	23
641666	3624.99	19.14	-5.7	13.44	22.08	23
645000	3675	19.37	-5.7	13.67	23.28	23

n48 50M DFT-s-OFDM 16QAM(SCS 15 kHz)						
Channel	Frequency (MHz)	Conducted Power (dBm)	Gain (dB)	EIRP (dBm)	EIRP (mW)	Lmit (dBm/10Mhz)
638334	3575.01	18.18	-5.7	12.48	17.7	23
641666	3624.99	18.15	-5.7	12.45	17.58	23
645000	3675	18.22	-5.7	12.52	17.86	23

n48 50M DFT-s-OFDM 64QAM(SCS 15 kHz)						
Channel	Frequency (MHz)	Conducted Power (dBm)	Gain (dB)	EIRP (dBm)	EIRP (mW)	Lmit (dBm/10Mhz)
638334	3575.01	16.9	-5.7	11.2	13.18	23
641666	3624.99	16.85	-5.7	11.15	13.03	23
645000	3675	17.05	-5.7	11.35	13.65	23

n48 50M DFT-s-OFDM 256QAM(SCS 15 kHz)						
Channel	Frequency (MHz)	Conducted Power (dBm)	Gain (dB)	EIRP (dBm)	EIRP (mW)	Lmit (dBm/10Mhz)
638334	3575.01	14.7	-5.7	9	7.94	23
641666	3624.99	14.85	-5.7	9.15	8.22	23
645000	3675	14.7	-5.7	9	7.94	23



n48 40M DFT-s-OFDM QPSK(SCS 15 kHz)						
Channel	Frequency (MHz)	Conducted Power (dBm)	Gain (dB)	EIRP (dBm)	EIRP (mW)	Lmit (dBm/10Mhz)
638000	3570	18.94	-5.7	13.24	21.09	23
641666	3624.99	18.91	-5.7	13.21	20.94	23
645332	3679.98	19.2	-5.7	13.5	22.39	23

n48 20M DFT-s-OFDM QPSK(SCS 15 kHz)						
Channel	Frequency (MHz)	Conducted Power (dBm)	Gain (dB)	EIRP (dBm)	EIRP (mW)	Lmit (dBm/10Mhz)
637334	3560.01	18.95	-5.7	13.25	21.13	23
641666	3624.99	19.13	-5.7	13.43	22.03	23
646000	3690	19.23	-5.7	13.53	22.54	23

n48 15M DFT-s-OFDM QPSK(SCS 15 kHz)						
Channel	Frequency (MHz)	Conducted Power (dBm)	Gain (dB)	EIRP (dBm)	EIRP (mW)	Lmit (dBm/10Mhz)
637168	3557.52	18.93	-5.7	13.23	21.04	23
641666	3624.99	18.92	-5.7	13.22	20.99	23
646166	3692.49	19.18	-5.7	13.48	22.28	23

n48 10M DFT-s-OFDM QPSK(SCS 15 kHz)						
Channel	Frequency (MHz)	Conducted Power (dBm)	Gain (dB)	EIRP (dBm)	EIRP (mW)	Lmit (dBm/10Mhz)
637000	3555	18.86	-5.7	13.16	20.7	23
641666	3624.99	19.06	-5.7	13.36	21.68	23
646332	3694.98	18.97	-5.7	13.27	21.23	23



ANT 5(UP):

n48 50M DFT-s-OFDM Pi/2 BPSK(SCS 15 kHz)						
Channel	Frequency (MHz)	Conducted Power (dBm)	Gain (dB)	EIRP (dBm)	EIRP (mW)	Lmit (dBm/10Mhz)
638334	3575.01	22.46	-0.2	22.26	168.27	23
641666	3624.99	22.5	-0.2	22.3	169.82	23
645000	3675	22.45	-0.2	22.25	167.88	23

n48 50M DFT-s-OFDM QPSK(SCS 15 kHz)						
Channel	Frequency (MHz)	Conducted Power (dBm)	Gain (dB)	EIRP (dBm)	EIRP (mW)	Lmit (dBm/10Mhz)
638334	3575.01	22.52	-0.2	22.32	170.61	23
641666	3624.99	22.45	-0.2	22.25	167.88	23
645000	3675	22.49	-0.2	22.29	169.43	23

n48 50M DFT-s-OFDM 16QAM(SCS 15 kHz)						
Channel	Frequency (MHz)	Conducted Power (dBm)	Gain (dB)	EIRP (dBm)	EIRP (mW)	Lmit (dBm/10Mhz)
638334	3575.01	22.3	-0.2	22.1	162.18	23
641666	3624.99	22.05	-0.2	21.85	153.11	23
645000	3675	22.1	-0.2	21.9	154.88	23

n48 50M DFT-s-OFDM 64QAM(SCS 15 kHz)						
Channel	Frequency (MHz)	Conducted Power (dBm)	Gain (dB)	EIRP (dBm)	EIRP (mW)	Lmit (dBm/10Mhz)
638334	3575.01	20.98	-0.2	20.78	119.67	23
641666	3624.99	20.99	-0.2	20.79	119.95	23
645000	3675	20.89	-0.2	20.69	117.22	23

n48 50M DFT-s-OFDM 256QAM(SCS 15 kHz)						
Channel	Frequency (MHz)	Conducted Power (dBm)	Gain (dB)	EIRP (dBm)	EIRP (mW)	Lmit (dBm/10Mhz)
638334	3575.01	19.15	-0.2	18.95	78.52	23
641666	3624.99	19.02	-0.2	18.82	76.21	23
645000	3675	19	-0.2	18.8	75.86	23



n48 40M DFT-s-OFDM QPSK(SCS 15 kHz)						
Channel	Frequency (MHz)	Conducted Power (dBm)	Gain (dB)	EIRP (dBm)	EIRP (mW)	Lmit (dBm/10Mhz)
638000	3570	22.35	-0.2	22.15	164.06	23
641666	3624.99	22.49	-0.2	22.29	169.43	23
645332	3679.98	22.16	-0.2	21.96	157.04	23

n48 20M DFT-s-OFDM QPSK(SCS 15 kHz)						
Channel	Frequency (MHz)	Conducted Power (dBm)	Gain (dB)	EIRP (dBm)	EIRP (mW)	Lmit (dBm/10Mhz)
637334	3560.01	22.18	-0.2	21.98	157.76	23
641666	3624.99	22.13	-0.2	21.93	155.96	23
646000	3690	22.23	-0.2	22.03	159.59	23

n48 15M DFT-s-OFDM QPSK(SCS 15 kHz)						
Channel	Frequency (MHz)	Conducted Power (dBm)	Gain (dB)	EIRP (dBm)	EIRP (mW)	Lmit (dBm/10Mhz)
637168	3557.52	22.18	-0.2	21.98	157.76	23
641666	3624.99	22.19	-0.2	21.99	158.12	23
646166	3692.49	22.42	-0.2	22.22	166.72	23

n48 10M DFT-s-OFDM QPSK(SCS 15 kHz)						
Channel	Frequency (MHz)	Conducted Power (dBm)	Gain (dB)	EIRP (dBm)	EIRP (mW)	Lmit (dBm/10Mhz)
637000	3555	22.2	-0.2	22	158.49	23
641666	3624.99	22.32	-0.2	22.12	162.93	23
646332	3694.98	22.28	-0.2	22.08	161.44	23



ANT 7(UP):

n48 50M DFT-s-OFDM Pi/2 BPSK(SCS 15 kHz)						
Channel	Frequency (MHz)	Conducted Power (dBm)	Gain (dB)	EIRP (dBm)	EIRP (mW)	Lmit (dBm/10Mhz)
638334	3575.01	21.25	-0.1	21.15	130.32	23
641666	3624.99	21.21	-0.1	21.11	129.12	23
645000	3675	21.21	-0.1	21.11	129.12	23

n48 50M DFT-s-OFDM QPSK(SCS 15 kHz)						
Channel	Frequency (MHz)	Conducted Power (dBm)	Gain (dB)	EIRP (dBm)	EIRP (mW)	Lmit (dBm/10Mhz)
638334	3575.01	21.29	-0.1	21.19	131.52	23
641666	3624.99	21.22	-0.1	21.12	129.42	23
645000	3675	21.29	-0.1	21.19	131.52	23

n48 50M DFT-s-OFDM 16QAM(SCS 15 kHz)						
Channel	Frequency (MHz)	Conducted Power (dBm)	Gain (dB)	EIRP (dBm)	EIRP (mW)	Lmit (dBm/10Mhz)
638334	3575.01	20.3	-0.1	20.2	104.71	23
641666	3624.99	20.34	-0.1	20.24	105.68	23
645000	3675	20.61	-0.1	20.51	112.46	23

n48 50M DFT-s-OFDM 64QAM(SCS 15 kHz)						
Channel	Frequency (MHz)	Conducted Power (dBm)	Gain (dB)	EIRP (dBm)	EIRP (mW)	Lmit (dBm/10Mhz)
638334	3575.01	19.06	-0.1	18.96	78.7	23
641666	3624.99	19.26	-0.1	19.16	82.41	23
645000	3675	19.37	-0.1	19.27	84.53	23

n48 50M DFT-s-OFDM 256QAM(SCS 15 kHz)						
Channel	Frequency (MHz)	Conducted Power (dBm)	Gain (dB)	EIRP (dBm)	EIRP (mW)	Lmit (dBm/10Mhz)
638334	3575.01	17.39	-0.1	17.29	53.58	23
641666	3624.99	17.13	-0.1	17.03	50.47	23
645000	3675	17.36	-0.1	17.26	53.21	23



n48 40M DFT-s-OFDM QPSK(SCS 15 kHz)						
Channel	Frequency (MHz)	Conducted Power (dBm)	Gain (dB)	EIRP (dBm)	EIRP (mW)	Lmit (dBm/10Mhz)
638000	3570	20.9	-0.1	20.8	120.23	23
641666	3624.99	20.79	-0.1	20.69	117.22	23
645332	3679.98	21.04	-0.1	20.94	124.17	23

n48 20M DFT-s-OFDM QPSK(SCS 15 kHz)						
Channel	Frequency (MHz)	Conducted Power (dBm)	Gain (dB)	EIRP (dBm)	EIRP (mW)	Lmit (dBm/10Mhz)
637334	3560.01	20.99	-0.1	20.89	122.74	23
641666	3624.99	20.68	-0.1	20.58	114.29	23
646000	3690	20.85	-0.1	20.75	118.85	23

n48 15M DFT-s-OFDM QPSK(SCS 15 kHz)						
Channel	Frequency (MHz)	Conducted Power (dBm)	Gain (dB)	EIRP (dBm)	EIRP (mW)	Lmit (dBm/10Mhz)
637168	3557.52	20.94	-0.1	20.84	121.34	23
641666	3624.99	20.84	-0.1	20.74	118.58	23
646166	3692.49	20.93	-0.1	20.83	121.06	23

n48 10M DFT-s-OFDM QPSK(SCS 15 kHz)						
Channel	Frequency (MHz)	Conducted Power (dBm)	Gain (dB)	EIRP (dBm)	EIRP (mW)	Lmit (dBm/10Mhz)
637000	3555	20.85	-0.1	20.75	118.85	23
641666	3624.99	20.87	-0.1	20.77	119.4	23
646332	3694.98	20.98	-0.1	20.88	122.46	23

3.2 CONDUCTED BAND EDGE

3.2.1 LIMITS OF CONDUCTED BAND EDGE MEASUREMENT

The conducted power of any End User Device emission outside the fundamental emission (whether in or outside of the authorized band) shall not exceed -13 dBm/MHz within 0 to B megahertz (where B is the bandwidth in megahertz of the assigned channel or multiple contiguous channels of the End User Device) above the upper CBSD-assigned channel edge and within 0 to B megahertz below the lower CBSD-assigned channel edge. At all frequencies greater than B megahertz above the upper CBSD assigned channel edge and less than B megahertz below the lower CBSD-assigned channel edge, the conducted power of any End User Device emission shall not exceed -25 dBm/MHz. Notwithstanding the emission limits in this paragraph, the Adjacent Channel Leakage Ratio for End User Devices shall be at least 30 dB.

3.2.2 TEST SETUP

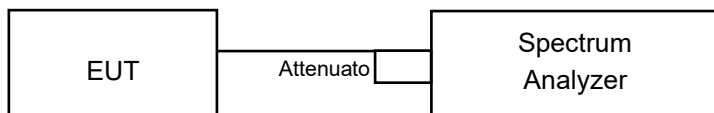

3.2.3 TEST INSTRUMENTS

Refer to section 1.2 to get information of above instrument.

3.2.4 TEST PROCEDURE

For the Conducted Band Edge:

- a. Connect the transmitter to the spectrum analyzer via coaxial cable while ensuring proper impedance matching.
- b. Tune the analyzer to the nominal center frequency of the emission bandwidth (EBW).
- c. Set the resolution bandwidth (RBW) $\geq 1\%$ EBW in the 1MHz band immediately outside and adjacent to the band edge.
- d. Beyond the 1MHz band from the band edge, RBW=1MHz was used.
- e. Set the video bandwidth (VBW) to $\geq 3 \times$ RBW.
- f. Select the average power (RMS) display detector.
- g. Set the number of measurement points to ≥ 1001 .
- h. Use auto-coupled sweep time.
- i. Perform the measurement over an interval of time when the transmission is continuous and at its maximum power level.
- j. The RF fundamental frequency should be excluded against the limit line in the operating frequency band and use RBW is 10KHz or 100KHz.
- k. Record the max trace plot into the test report.

For Adjacent Channel Leakage Ratio (ACLR) measurement:

1. The Adjacent Channel Leakage Ratio (ACLR) is the ratio of the average power in the assigned aggregated channel bandwidth to the average power over the equivalent adjacent channel bandwidth.
2. The option ACLR of spectrum analyzer is used and measures the ACLR ratio by setting equivalent channel bandwidth.
3. The measured ACLR ratio shall be at least 30 dB.

3.2.5 DEVIATION FROM TEST STANDARD

No deviation.



Test Report No.: W7L-240618W002RF13

3.2.6 TEST RESULTS

Please Refer to Appendix Of this test report.



3.3 FREQUENCY STABILITY MEASUREMENT

3.3.1 LIMITS OF FREQUENCY STABILITY MEASUREMENT

The frequency stability shall be sufficient to ensure that the fundamental emission stays within the authorized frequency band.

3.3.2 TEST PROCEDURE

- Device is placed at the oven room. The oven room could control the temperatures and humidity. Power warm up is at least 15 min and power applied should perform before recording frequency error.
- EUT is connected the external power supply to control the DC input power. The test voltage range is from minimum to maximum working voltage. Each step shall be record the frequency error rate.
- The temperature range step is 10 degrees in this test items. All temperature levels shall be hold the $\pm 0.5^{\circ}\text{C}$ during the measurement testing. The each temperature step shall be at least 0.5 hours, consider the EUT could be test under the stability condition.

NOTE: The frequency error was recorded frequency error from the communication simulator.

3.3.3 TEST SETUP

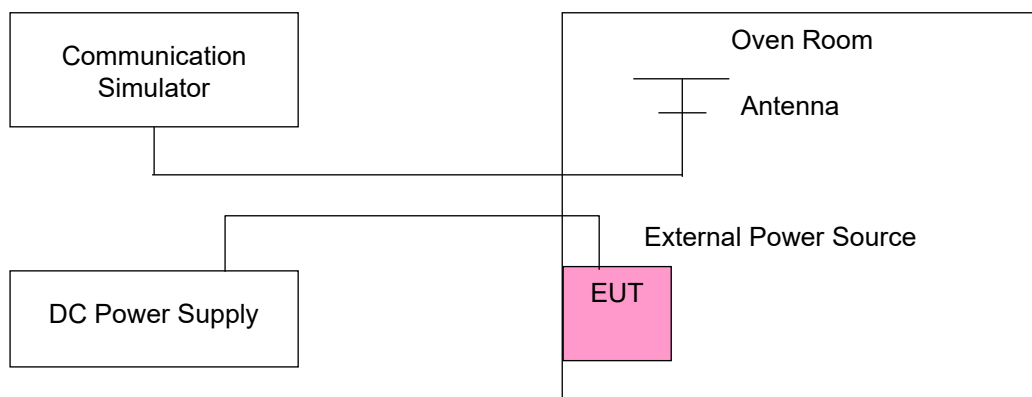



Test Report No.: W7L-240618W002RF13

3.3.4 TEST RESULTS

Please Refer to Appendix Of this test report.

Note: VL = Low voltage(3.7V); VN/NV = Normal voltage(3.91V); VH = High voltage(4.3V);
NT = Normal temperature (25°C)



3.4 OCCUPIED BANDWIDTH MEASUREMENT

3.4.1 OCCUPIED BANDWIDTH MEASUREMENT

The width of a frequency band such that, below the lower and above the upper frequency limits, the mean powers emitted are each equal to a specified percentage 0.5 %of the total mean power of a given emission.

3.4.2 TEST SETUP

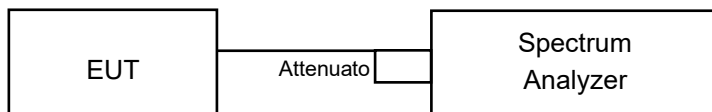

3.4.3 TEST INSTRUMENTS

Refer to section 1.2 to get information of above instrument.

3.4.4 TEST PROCEDURE

- a. The conducted occupied bandwidth used the power splitter via EUT RF power connector between simulation base station and spectrum analyzer.
- b. Use OBW measurement function of Spectrum analyzer to measure 99 % occupied bandwidth.

3.4.5 DEVIATION FROM TEST STANDARD

No deviation.



Test Report No.: W7L-240618W002RF13

3.4.6 TEST RESULT

Please Refer to Appendix Of this test report.

3.5 CONDUCTED SPURIOUS EMISSIONS

3.5.1 LIMITS OF CONDUCTED SPURIOUS EMISSIONS MEASUREMENT

The power of any emissions below 3530 MHz or above 3720 MHz shall not exceed -40dBm/MHz.

3.5.2 TEST SETUP

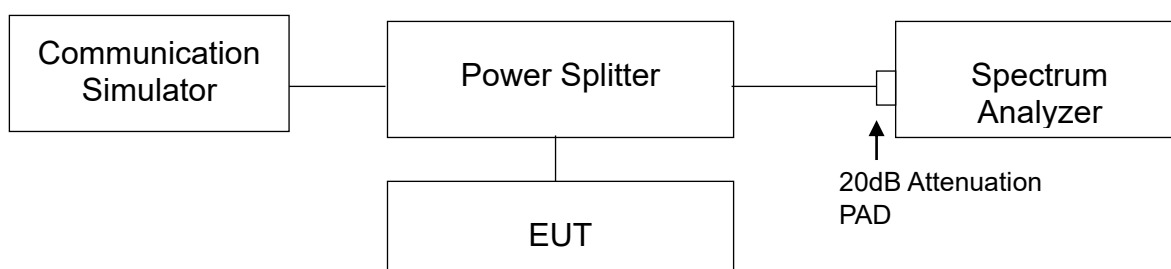

3.5.3 TEST PROCEDURE

- The EUT makes a phone call to the communication simulator. All measurements were done at low, middle and high operational frequency range.
- Measuring frequency range is from 9 kHz to 40 GHz. 20dB attenuation pad is connected with spectrum. RBW=1MHz and VBW=3MHz is used for conducted emission measurement.