



Test Report No.: W7L-240618W002RF03



FCC TEST REPORT

(Part 15, Subpart E)

Applicant:	Xiaomi Communications Co., Ltd.
Address:	#019, 9th Floor, Building 6, 33 Xi'erqi Middle Road, Haidian District, Beijing, China, 100085

Manufacturer or Supplier:	Xiaomi Communications Co., Ltd.
Address:	#019, 9th Floor, Building 6, 33 Xi'erqi Middle Road, Haidian District, Beijing, China, 100085
Product:	Mobile Phone
Brand Name:	POCO
Model Name:	2409FPCC4G
FCC ID:	2AFZZPCC4G
Date of tests:	Jul. 12, 2024 ~ Aug. 05, 2024

The tests have been carried out according to the requirements of the following standard:

FCC Part 15, Subpart E, Section 15.407

CONCLUSION: The submitted sample was found to COMPLY with the test requirement

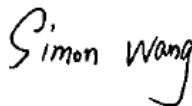
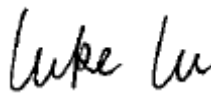
Prepared by Simon Wang Engineer / Mobile Department	Approved by Luke Lu Manager / Mobile Department
 Date: Aug. 05, 2024	 Date: Aug. 05, 2024

This report is governed by, and incorporates by reference, the Conditions of Testing as posted at the date of issuance of this report at <http://www.bureauveritas.com/home/about-us/our-business/cps/about-us/terms-conditions/> and is intended for your exclusive use. Any copying or replication of this report to or for any other person or entity, or use of our name or trademark, is permitted only with our prior written permission. This report sets forth our findings solely with respect to the test samples identified herein. The results set forth in this report are not indicative or representative of the quality or characteristics of the lot from which a test sample was taken or any similar or identical product unless specifically and expressly noted. Our report includes all of the tests requested by you and the results thereof based upon the information that you provided to us. Measurement uncertainty is only provided upon request for accredited tests. Statements of conformity are based on simple acceptance criteria without taking measurement uncertainty into account, unless otherwise requested in writing. You have 60 days from date of issuance of this report to notify us of any material error or omission caused by our negligence or if you require measurement uncertainty; provided, however, that such notice shall be in writing and shall specifically address the issue you wish to raise. A failure to raise such issue within the prescribed time shall constitute your unqualified acceptance of the completeness of this report, the tests conducted and the correctness of the report contents.



TABLE OF CONTENTS

RELEASE CONTROL RECORD	4
1 SUMMARY OF TEST RESULTS	5
1.1 MEASUREMENT UNCERTAINTY	6
2 GENERAL INFORMATION.....	7
2.1 GENERAL DESCRIPTION OF EUT.....	7
2.2 DESCRIPTION OF TEST MODES.....	9
2.2.1 TEST MODE APPLICABILITY AND TESTED CHANNEL DETAIL.....	12
2.3 DUTY CYCLE OF TEST SIGNAL.....	17
2.4 DESCRIPTION OF SUPPORT UNITS.....	18
2.4.1 CONFIGURATION OF SYSTEM UNDER TEST.....	19
2.5 GENERAL DESCRIPTION OF APPLIED STANDARDS.....	20
3 TEST TYPES AND RESULTS.....	21
3.1 RADIATED EMISSION AND BANDEDGE MEASUREMENT	21
3.1.1 LIMITS OF RADIATED EMISSION AND BANDEDGE MEASUREMENT.....	21
3.1.2 LIMITS OF UNWANTED EMISSION.....	21
3.1.3 TEST INSTRUMENTS.....	22
3.1.4 TEST PROCEDURES	23
3.1.5 DEVIATION FROM TEST STANDARD	23
3.1.6 TEST SETUP.....	24
3.1.7 EUT OPERATING CONDITION	25
3.1.8 TEST RESULTS	26
3.2 CONDUCTED EMISSION MEASUREMENT.....	86
3.2.1 LIMITS OF CONDUCTED EMISSION MEASUREMENT	86
3.2.2 TEST INSTRUMENTS.....	86
3.2.3 TEST PROCEDURES	86
3.2.4 DEVIATION FROM TEST STANDARD	87
3.2.5 TEST SETUP.....	87
3.2.6 EUT OPERATING CONDITIONS	87
3.2.7 TEST RESULTS	88
3.3 MAXIMUM CONDUCTED OUTPUT POWER MEASUREMENT	90
3.3.1 LIMITS OF MAXIMUM CONDUCTED OUTPUT POWER MEASUREMENT	90
3.3.2 TEST SETUP.....	91
3.3.3 TEST INSTRUMENTS.....	91



3.3.4	TEST PROCEDURE	92
3.3.5	DEVIATION FROM TEST STANDARD	94
3.3.6	EUT OPERATING CONDITIONS	94
3.3.7	TEST RESULTS	95
3.4	MAXIMUM POWER SPECTRAL DENSITY MEASUREMENT	96
3.4.1	LIMITS OF MAXIMUM POWER SPECTRAL DENSITY MEASUREMENT	96
3.4.2	TEST SETUP	96
3.4.3	TEST INSTRUMENTS	96
3.4.4	TEST PROCEDURES	97
3.4.5	DEVIATION FROM TEST STANDARD	97
3.4.6	EUT OPERATING CONDITIONS	97
3.4.7	TEST RESULTS	98
3.5	AUTOMATICALLY DISCONTINUE TRANSMISSION	99
3.5.1	LIMIT OF AUTOMATICALLY DISCONTINUE TRANSMISSION	99
3.5.2	TEST INSTRUMENTS	99
3.5.3	TEST RESULT	99
3.6	ANTENNA REQUIREMENTS	100
3.6.1	STANDARD APPLICABLE	100
3.6.2	ANTENNA CONNECTED CONSTRUCTION	100
3.6.3	ANTENNA GAIN	100
4	PHOTOGRAPHS OF THE TEST CONFIGURATION	100
5	MODIFICATIONS RECORDERS FOR ENGINEERING CHANGES TO THE EUT BY THE LAB	101
6	APPENDIX.....	102



BUREAU
VERITAS

Test Report No.: W7L-240618W002RF03

RELEASE CONTROL RECORD

ISSUE NO.	REASON FOR CHANGE	DATE ISSUED
W7L-240618W002RF03	Original release	Aug. 05, 2024



1 SUMMARY OF TEST RESULTS

The EUT has been tested according to the following specifications:

APPLIED STANDARD: FCC PART 15, SUBPART E		
STANDARD SECTION	TEST TYPE AND LIMIT	RESULT
15.407(b)(9)	AC Power Conducted Emission	Compliance
15.407(b) (1/2/3/4/5)	Radiated Emission & Band Edge Measurement	Compliance
15.407(a/1/2/3)	Maximum conducted output Power	Compliance
15.407(a/1/2/3)	Peak Power Spectral Density	Compliance
15.407(a)(2)(12)	26 dB Bandwidth	Compliance
15.407(e)	6 dB Bandwidth	Compliance
15.203	Antenna Requirement	Compliance

NOTE:

1. Except the data of RSE and Band Edge Measurement, other data please refer to Appendix.
2. This report refers to the data of W7L-240618W001RF03(FCC ID: 2AFZZRAD4G), the difference of 24094RAD4G and 2409FPCC4G is model, FCC ID, brand name and 2409FPCC4G remove one camera. This report verify power and RSE worse case, retest AC Power Conducted Emission(CE). The verified power is similar as the original report. So this report only update the RSE worse case(11ac80 CH58) and retesting CE, other data of spot-Check Please Refer to folder the naming (xiaomi O17p Spot-check).
3. List of the verified results (worse case) in the test item as follows:

Test Item / Report No.	W7L-240618W001RF03	W7L-240618W002RF03
Radiated Emission and Band edge Measurement	11ac80 CH58 Margin:-4.17Db	11ac80 CH58 Margin:-4.22Db
Remark: All validation data are within 3dB variation or better, the new result is better than the original data.		



1.1 MEASUREMENT UNCERTAINTY

Where relevant, the following measurement uncertainty levels have been estimated for tests performed on the EUT as specified in CISPR 16-4-2:

MEASUREMENT	UNCERTAINTY
AC Power Conducted emissions	±2.70dB
Radiated emissions (9KHz~30MHz)	±2.68dB
Radiated emissions (30MHz~1GHz)	±4.98dB
Radiated emissions (1GHz ~6GHz)	±4.70dB
Radiated emissions (6GHz ~18GHz)	±4.60dB
Radiated emissions (18GHz ~40GHz)	±4.12dB
Conducted emissions	±4.01dB
Occupied Channel Bandwidth	±43.58KHz
Conducted Output power	±2.06dB
Power Spectral Density	±0.85 dB

This uncertainty represents an expanded uncertainty expressed at approximately the 95% confidence level using a coverage factor of $k = 2$.



2 GENERAL INFORMATION

2.1 GENERAL DESCRIPTION OF EUT

PRODUCT	Mobile Phone
BRAND NAME	POCO
MODEL NAME	2409FPCC4G
NOMINAL VOLTAGE	5/5~11Vdc(adapter or host equipment) 3.91Vdc (Li-ion, battery)
MODULATION	OFDM
TRANSFER RATE	802.11a: 54.0/ 48.0/ 36.0/ 24.0/ 18.0/ 12.0/ 9.0/ 6.0Mbps 802.11n: up to 150.0Mbps 802.11ac: up to 433.3Mbps
OPERATING FREQUENCY	5180 ~ 5240MHz, 5260 ~ 5320MHz, 5500 ~ 5720MHz, 5745 ~ 5825MHz
NUMBER OF CHANNEL	5180 ~ 5240MHz: 4 for 802.11a, 802.11n/ac/ax (20MHz) 2 for 802.11n/ac(40MHz) 1 for 802. 802.11ac (80MHz)/ 5260 ~ 5320MHz: 4 for 802.11a, 802.11n/ac/ax (20MHz) 2 for 802.11n/ac (40MHz) 1 for 802.11ac (80MHz) 5500 ~ 5720MHz: 12 for 802.11a, 802.11n/ac (20MHz)/ 6 for 802.11n/ac (40MHz) 3 for 802.11ac (80MHz) 5745 ~ 5825MHz: 5 for 802.11a, 802.11n/ac (20MHz) 2 for 802.11n/ac (40MHz) 1 for 802.11ac (80MHz)
MAX. OUTPUT POWER	26.85 mW for 5180 ~ 5240MHz 28.12 mW for 5260 ~ 5320MHz 30.34 mW for 5500 ~ 5720MHz 27.80 mW for 5745 ~ 5825MHz
ANTENNA TYPE	PIFA Antenna
ANTENNA GAIN	-1.9dBi for 5180 ~ 5240MHz -2.1dBi for 5260 ~ 5320MHz -2.3dBi for 5500 ~ 5720MHz -2.1dBi for 5745 ~ 5825MHz
HW VERSION	13510O17P
SW VERSION	Xiaomi HyperOS 1.0



IMEI	861781070039865
I/O PORTS	Refer to user's manual
CABLE SUPPLIED	USB cable1: non-shielded cable, with w/o ferrite core, 1.0 meter USB cable2: non-shielded cable, with w/o ferrite core, 1.0 meter

NOTE:

1. For a more detailed features description, please refer to the manufacturer's specifications or the user's manual.
2. The EUT incorporates a SISO function. Physically, the EUT provides one completed transmitter and one receiver.

MODULATION MODE	TX FUNCTION
802.11a	1TX /1RX
802.11n/802.11ac (20MHz)	1TX /1RX
802.11n/802.11ac (40MHz)	1TX /1RX
802.11ac (80MHz)	1TX /1RX

3. For the test results, the EUT had been tested with all conditions. But only the worst case was shown in the test report.
4. Antenna gain and EUT conducted cable loss are provided by the customer, and the laboratory will record the results based on these items that involve these two parameters.



2.2 DESCRIPTION OF TEST MODES

FOR 5180 ~ 5240MHz

4 channels are provided for 802.11a, 802.11n, 802.11ac (20MHz)

CHANNEL	FREQUENCY	CHANNEL	FREQUENCY
36	5180 MHz	44	5220 MHz
40	5200 MHz	48	5240 MHz

2 channels are provided for 802.11n, 802.11ac (40MHz):

CHANNEL	FREQUENCY	CHANNEL	FREQUENCY
38	5190 MHz	46	5230 MHz

1 channel is provided for 802.11ac (80MHz):

CHANNEL	FREQUENCY	CHANNEL	FREQUENCY
42	5210 MHz		

FOR 5260 ~ 5320MHz

4 channels are provided for 802.11a, 802.11n, 802.11ac (20MHz):

CHANNEL	FREQUENCY	CHANNEL	FREQUENCY
52	5260 MHz	60	5300 MHz
56	5280 MHz	64	5320 MHz

2 channels are provided for 802.11n, 802.11ac (40MHz):

CHANNEL	FREQUENCY	CHANNEL	FREQUENCY
54	5270 MHz	62	5310 MHz

1 channel is provided for 802.11ac (80MHz):

CHANNEL	FREQUENCY	CHANNEL	FREQUENCY
58	5290 MHz		



FOR 5500 ~ 5720MHz

12 channels are provided for 802.11a, 802.11n, 802.11ac (20MHz):

CHANNEL	FREQUENCY	CHANNEL	FREQUENCY
100	5500 MHz	124	5620MHz
104	5520 MHz	128	5640MHz
108	5540 MHz	132	5660 MHz
112	5560 MHz	136	5680 MHz
116	5580 MHz	140	5700 MHz
120	5600 MHz	144	5720 MHz

6 channels are provided for 802.11n, 802.11ac (40MHz):

CHANNEL	FREQUENCY	CHANNEL	FREQUENCY
102	5510 MHz	126	5630MHz
110	5550 MHz	134	5670 MHz
118	5590 MHz	142	5710 MHz

3 channel is provided for 802.11ac (80MHz):

CHANNEL	FREQUENCY	CHANNEL	FREQUENCY
106	5530 MHz	138	5690 MHz
122	5610 MHz		



FOR 5745 ~ 5825MHz

5 channels are provided for 802.11a, 802.11n, 802.11ac (20MHz):

CHANNEL	FREQUENCY	CHANNEL	FREQUENCY
149	5745 MHz	161	5805 MHz
153	5765 MHz	165	5825 MHz
157	5785 MHz		

2 channels are provided for 802.11n, 802.11ac (40MHz):

CHANNEL	FREQUENCY	CHANNEL	FREQUENCY
142	5710 MHz	159	5795 MHz
151	5755 MHz		

1 channel is provided for 802.11ac (80MHz):

CHANNEL	FREQUENCY
155	5775 MHz



2.2.1 TEST MODE APPLICABILITY AND TESTED CHANNEL DETAIL

EUT CONFIGURE MODE	APPLICABLE TO				DESCRIPTION
	RE≥1G	RE<1G	PLC	APCM	
A	√	√	√	-	Powered by Adapter with wifi(5G) link
B	-	-	-	√	Powered by Battery with wifi(5G) link
C	-	-	-	-	Powered by USB with wifi(5G) link

Where **RE≥1G**: Radiated Emission above 1GHz **RE<1G**: Radiated Emission below 1GHz
PLC: Power Line Conducted Emission **APCM**: Antenna Port Conducted Measurement

NOTE:
The EUT had been pre-tested on the positioned of each 3 axis. The worst case was found when positioned on **X-plane**.
NOTE: "-" means no effect

RADIATED EMISSION TEST (BELOW 1GHz):

- Pre-Scan has been conducted to determine the worst-case mode from all possible combinations between available modulations, data rates and antenna ports (if EUT with antenna diversity architecture).
- The following channel(s) was (were) selected for the final test as listed below.

EUT CONFIGURE MODE	MODE	FREQ. BAND (MHz)	AVAILABLE CHANNEL	TESTED CHANNEL	MODULATION	DATA RATE (Mbps)
A	802.11ac (80MHz)	5260-5320	58	58	OFDM	MCS0



RADIATED EMISSION TEST (ABOVE 1GHz):

- Pre-Scan has been conducted to determine the worst-case mode from all possible combinations between available modulations, data rates and antenna ports (if EUT with antenna diversity architecture).
- The following channel(s) was (were) selected for the final test as listed below.

EUT CONFIGURE MODE	MODE	FREQ. BAND (MHz)	AVAILABLE CHANNEL	TESTED CHANNEL	MODULATION	DATA RATE (Mbps)
A	802.11a	5180-5240	36 to 48	36, 40, 48	OFDM	6.0
A	802.11n/ac (20MHz)		36 to 48	36, 40, 48	OFDM	MCS0
A	802.11n/ac (40MHz)		38 to 46	38, 46	OFDM	MCS0
A	802.11ac (80MHz)		42	42	OFDM	MCS0
A	802.11a	5260-5320	52 to 64	52, 60, 64	OFDM	6.0
A	802.11n/ac (20MHz)		52 to 64	52, 60, 64	OFDM	MCS0
A	802.11n/ac/ (40MHz)		54 to 62	54, 62	OFDM	MCS0
A	802.11ac (80MHz)		58	58	OFDM	MCS0
A	802.11a	5500-5720	100 to 144	100, 116, 140, 144	OFDM	6.0
A	802.11n/ac (20MHz)		100 to 144	100, 116, 140, 144	OFDM	MCS0
A	802.11n/ac (40MHz)		102 to 142	102, 110, 134, 142	OFDM	MCS0
A	802.11ac (80MHz)		106 to 138	106, 122, 138	OFDM	MCS0
A	802.11a	5745-5825	149 to 165	149, 157,165	OFDM	6.0
A	802.11n/ac (20MHz)		149 to 165	149, 157,165	OFDM	MCS0
A	802.11n/ac (40MHz)		151 to 159	151, 159	OFDM	MCS0
A	802.11ac (80MHz)		155	155	OFDM	MCS0



POWER LINE CONDUCTED EMISSION TEST:

- Pre-Scan has been conducted to determine the worst-case mode from all possible combinations between available modulations, data rates and antenna ports (if EUT with antenna diversity architecture).
- The following channel(s) was (were) selected for the final test as listed below.

EUT CONFIGURE MODE	MODE	FREQ. BAND (MHz)	AVAILABLE CHANNEL	TESTED CHANNEL	MODULATION	DATA RATE (Mbps)
A	802.11ac (80MHz)	5260-5320	58	58	OFDM	MCS0

BANDEDGE MEASUREMENT:

- Pre-Scan has been conducted to determine the worst-case mode from all possible combinations between available modulations, data rates and antenna ports (if EUT with antenna diversity architecture).
- The following channel(s) was (were) selected for the final test as listed below.

EUT CONFIGURE MODE	MODE	FREQ. BAND (MHz)	AVAILABLE CHANNEL	TESTED CHANNEL	MODULATION	DATA RATE (Mbps)
A	802.11a	5180-5240	36 to 48	36, 40, 48	OFDM	6.0
A	802.11n/ac (20MHz)		36 to 48	36, 40, 48	OFDM	MCS0
A	802.11n/ac (40MHz)		38 to 46	38, 46	OFDM	MCS0
A	802.11ac (80MHz)		42	42	OFDM	MCS0
A	802.11a	5260-5320	52 to 64	52, 60, 64	OFDM	6.0
A	802.11n/ac (20MHz)		52 to 64	52, 60, 64	OFDM	MCS0
A	802.11n/ac (40MHz)		54 to 62	54, 62	OFDM	MCS0
A	802.11ac (80MHz)		58	58	OFDM	MCS0
A	802.11a	5500-5720	100 to 144	100, 116, 140, 144	OFDM	6.0
A	802.11n/ac (20MHz)		100 to 144	100, 116, 140, 144	OFDM	MCS0
A	802.11n/ac (40MHz)		102 to 142	102, 110, 134, 142	OFDM	MCS0
A	802.11ac (80MHz)		106 to 138	106, 122, 138	OFDM	MCS0
A	802.11a	5745-5825	149 to 165	149, 157, 165	OFDM	6.0
A	802.11n/ac (20MHz)		149 to 165	149, 157, 165	OFDM	MCS0
A	802.11n/ac (40MHz)		151 to 159	151, 159	OFDM	MCS0
A	802.11ac (80MHz)		155	155	OFDM	MCS0



ANTENNA PORT CONDUCTED MEASUREMENT:

- This item includes all test values of each mode, but only includes spectrum plot of worst value of each mode.
- Pre-Scan has been conducted to determine the worst-case mode from all possible combinations between available modulations, data rates and antenna ports (if EUT with antenna diversity architecture).
- The following channel(s) was (were) selected for the final test as listed below.

EUT CONFIGURE MODE	MODE	FREQ. BAND (MHz)	AVAILABLE CHANNEL	TESTED CHANNEL	MODULATION	DATA RATE (Mbps)
A	802.11a	5180-5240	36 to 48	36, 40, 48	OFDM	6.0
A	802.11n/ac (20MHz)		36 to 48	36, 40, 48	OFDM	MCS0
A	802.11n/ac (40MHz)		38 to 46	38, 46	OFDM	MCS0
A	802.11ac (80MHz)		42	42	OFDM	MCS0
A	802.11a	5260-5320	52 to 64	52, 60, 64	OFDM	6.0
A	802.11n/ac (20MHz)		52 to 64	52, 60, 64	OFDM	MCS0
A	802.11n/ac (40MHz)		54 to 62	54, 62	OFDM	MCS0
A	802.11ac (80MHz)		58	58	OFDM	MCS0
A	802.11a	5500-5720	100 to 144	100, 116, 140, 144	OFDM	6.0
A	802.11n/ac (20MHz)		100 to 144	100, 116, 140, 144	OFDM	MCS0
A	802.11n/ac (40MHz)		102 to 142	102, 110, 134, 142	OFDM	MCS0
A	802.11ac (80MHz)		106 to 138	106, 122, 138	OFDM	MCS0
A	802.11a	5745-5825	149 to 165	149, 157,165	OFDM	6.0
A	802.11n/ac (20MHz)		149 to 165	149, 157,165	OFDM	MCS0
A	802.11n/ac (40MHz)		151 to 159	151, 159	OFDM	MCS0
A	802.11ac (80MHz)		155	155	OFDM	MCS0



Test Report No.: W7L-240618W002RF03

TEST CONDITION:

APPLICABLE TO	ENVIRONMENTAL CONDITIONS	INPUT POWER	TESTED BY
RE<1G	23deg. C, 70%RH	DC 5/5~11V By Adapter	Jace Hu
RE≥1G	23deg. C, 70%RH	DC 5/5~11V By Adapter	Jace Hu
PLC	25deg. C, 52%RH	DC 5/5~11V By Adapter	James Fu
APCM	25deg. C, 60%RH	DC 3.91V By DC Supply	James Fu



Test Report No.: W7L-240618W002RF03

2.3 DUTY CYCLE OF TEST SIGNAL

Please Refer to Appendix Of this test report.



2.4 DESCRIPTION OF SUPPORT UNITS

The EUT has been tested as an independent unit together with other necessary accessories or support units. The following support units or accessories were used to form a representative test configuration during the tests.

NO.	PRODUCT	BRAND	MODEL NO.	SERIAL NO.	FCC ID
1	Desktop	Lenovo	M73 SFF	PC04GRQV	N/A
2	Desktop	Lenovo	M73 SFF	PC06CS27	N/A
3	Laptop	Lenovo	ThinkpadL440	R90FTFKN	N/A
4	DC source	Kikusui/JP	PMX18-5A	0000001	N/A

NO.	SIGNAL CABLE DESCRIPTION OF THE ABOVE SUPPORT UNITS
1	AC Line: Unshielded, Detachable 1.5m
2	AC Line: Unshielded, Detachable 1.5m
3	AC Line: Unshielded, Detachable 1.5m
4	DC Line: Unshielded, Detachable 1.0m



2.4.1 CONFIGURATION OF SYSTEM UNDER TEST

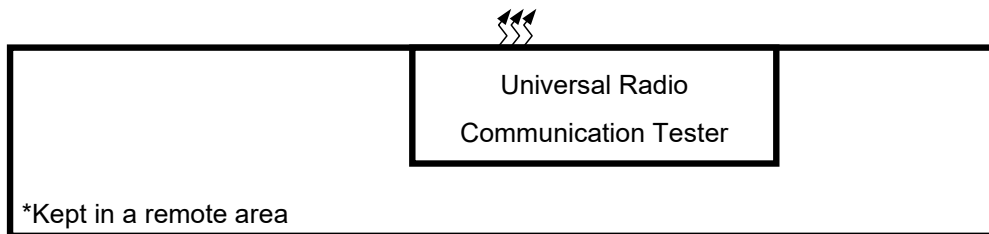
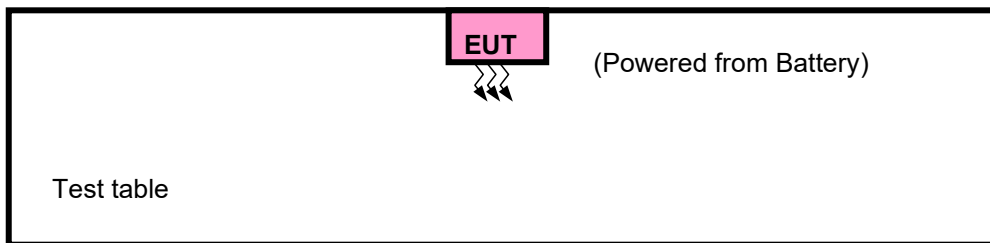
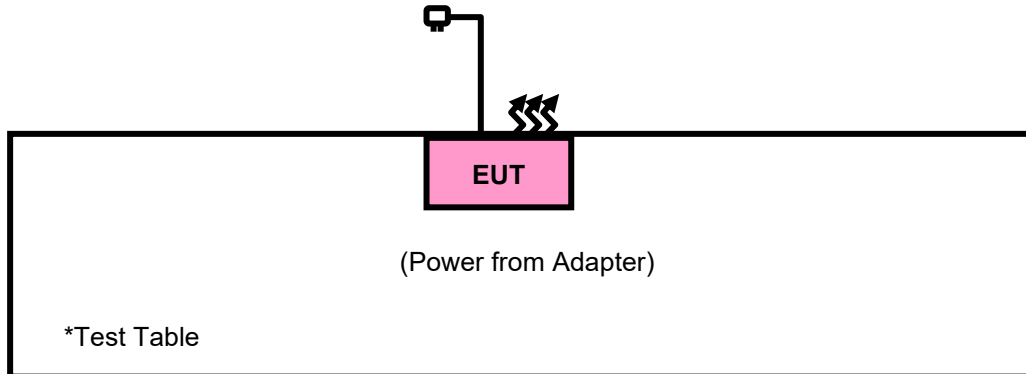



Test Report No.: W7L-240618W002RF03

2.5 GENERAL DESCRIPTION OF APPLIED STANDARDS

The EUT is a RF Product. According to the specifications of the manufacturer, it must comply with the requirements of the following standards:

FCC Part 15, Subpart E (15.407)

KDB 789033 D02 General U-NII Test Procedures New Rules v02r01

ANSI C63.10-2020

All test items have been performed and recorded as per the above standards.

NOTE: The EUT is also considered as a kind of computer peripheral, because the connection to computer is necessary for typical use. It has been verified to comply with the requirements of FCC Part 15, Subpart B, Class B (Certification). The test report has been issued separately.



3 TEST TYPES AND RESULTS

3.1 RADIATED EMISSION AND BANDEDGE MEASUREMENT

3.1.1 LIMITS OF RADIATED EMISSION AND BANDEDGE MEASUREMENT

Radiated emissions which fall in the restricted bands must comply with the radiated emission limits specified as below table:

FREQUENCIES (MHz)	FIELD STRENGTH (microvolts/meter)	MEASUREMENT DISTANCE (meters)
0.009 ~ 0.490	2400/F(kHz)	300
0.490 ~ 1.705	24000/F(kHz)	30
1.705 ~ 30.0	30	30
30 ~ 88	100	3
88 ~ 216	150	3
216 ~ 960	200	3
Above 960	500	3

NOTE:

1. The lower limit shall apply at the transition frequencies.
2. Emission level (dBuV/m) = 20 log Emission level (uV/m).
3. For frequencies above 1000MHz, the field strength limits are based on average detector, however, the peak field strength of any emission shall not exceed the maximum permitted average limits, specified above by more than 20dB under any condition of modulation.

3.1.2 LIMITS OF UNWANTED EMISSION

RESTRICTED BANDS	APPLICABLE TO	LIMIT	
	789033 D02 General UNII Test Procedures New Rules v02r01	FIELD STRENGTH AT 3m (dBµV/m)	
	PK : 74	AV : 54	
OUT OF THE RESTRICTED BANDS	APPLICABLE TO	EIRP LIMIT (dBm/MHz)	EQUIVALENT FIELD STRENGTH AT 3m (dBµV/m)
	15.407(b)(1)	PK : -27	PK : 68.2
	15.407(b)(2)		
	15.407(b)(3)		
15.407(b)(4)	See note 2 (FCC 16-24)		



NOTE: The following formula is used to convert the equipment isotropic radiated power (eirp) to field strength:

$$E = \frac{1000000 \sqrt{30P}}{3} \mu\text{V/m, where P is the eirp (Watts).}$$

2. All emissions shall be limited to a level of -27 dBm/MHz at 75 MHz or more above or below the band edge increasing linearly to 10 dBm/MHz at 25 MHz above or below the band edge, and from 25 MHz above or below the band edge increasing linearly to a level of 15.6 dBm/MHz at 5 MHz above or below the band edge, and from 5 MHz above or below the band edge increasing linearly to a level of 27 dBm/MHz at the band edge.

3.1.3 TEST INSTRUMENTS

Equipment	Manufacturer	Model No.	Serial No.	Last Cal.	Next Cal.
3m Semi-anechoic Chamber	ETS-LINDGREN	9m*6m*6m	Euroshieldpn-CT0001143-1216	Nov. 14,23	Nov. 13,26
Bilog Antenna	ETS-LINDGREN	3143B	00161965	Feb. 18,24	Feb. 17,25
Horn Antenna	ETS-LINDGREN	3117	00168692	Feb. 18,24	Feb. 17,25
Horn Antenna (18GHz-40GHz)	N/A	QWH-SL-18-40-K-SG/QMS-00361	15433	Sep.04, 23	Sep.03, 24
Test Software	E3	V 9.160323	N/A	N/A	N/A
Test Software	JS1120-3	3.2.06	N/A	N/A	N/A
10dB Attenuator	JFW/USA	50HF-010-SMA	N/A	May. 06,24	May. 05,25
MXE EMI Receiver	KEYSIGHT	N9038A-544	MY54450026	Mar. 28,24	Mar. 27,25
Signal Pre-Amplifier	EMSI	EMC 9135	980249	May. 06,24	May. 05,25
Signal Pre-Amplifier	EMSI	EMC 012645B	980257	May.10,24	May.09,25
Signal Pre-Amplifier	EMSI	EMC 184045B	980259	Feb. 17,24	Feb. 16,25
DC Source	Kikusui/JP	PMX18-5A	0000001	Aug. 12,23	Aug. 11,24
Power Meter	Anritsu	ML2495A	1506002	Feb. 14,24	Feb. 13,25
Power Sensor	Anritsu	MA2411B	1339352	Feb. 14,24	Feb. 13,25
Loop Antenna	Schwarzbeck	FMZB 1519B	00173	Sep.03,23	Sep.02,24

- NOTE:**
1. The calibration interval of the above test instruments is 12 months or 36 months, and the calibrations are traceable to CEPREI/CHINA, GRGT/CHINA, and NIM/CHINA.
 2. The test was performed in the 3m Chamber.
 3. The FCC Site Registration No. is 525120; The Designation No. is CN1171.

3.1.4 TEST PROCEDURES

- a. The EUT was placed on the top of a rotating table 0.8 meters (for below 1GHz) / 1.5 meters (for above 1GHz) above the ground at 3-meter chamber room for test. The table was rotated 360 degrees to determine the position of the highest radiation.
- b. The EUT was set 3 meters away from the interference-receiving antenna, which was mounted on the top of a variable-height antenna tower.
- c. The antenna is a broadband antenna, and its height varies from one meter to four meters above the ground to determine the maximum value of the field strength. Both horizontal and vertical polarizations of the antenna are set to make the measurement.
- d. For each suspected emission, the EUT was arranged to its worst case and then the antenna was tuned to heights from 1 meter to 4 meters and the rotatable table was turned from 0 degrees to 360 degrees to find the maximum reading.
- e. The test-receiver system was set to Peak Detect Function and Specified Bandwidth with Maximum Hold Mode.
- f. If the emission level of the EUT in peak mode was 10dB lower than the limit specified, then testing could be stopped and the peak values of the EUT would be reported. Otherwise the emissions that did not have 10dB margin would be re-tested one by one using peak, quasi-peak or average method as specified and then reported in a data sheet.

NOTE:

1. The resolution bandwidth and video bandwidth of test receiver/spectrum analyzer is 120kHz for Peak detection (PK) and Quasi-peak detection (QP) at frequency below 1GHz.
2. The resolution bandwidth of test receiver/spectrum analyzer is 1MHz and video bandwidth is 3MHz for Peak detection at frequency above 1GHz.
3. The resolution bandwidth of test receiver/spectrum analyzer is 1MHz and the video bandwidth is 3MHz for RMS Average (Duty cycle < 98%) for Average detection (AV) at frequency above 1GHz, then the measurement results was added to a correction factor ($10 \log(1/\text{duty cycle})$).
4. The resolution bandwidth of test receiver/spectrum analyzer is 1MHz and the video bandwidth is 10Hz (Duty cycle \geq 98%) for Average detection (AV) at frequency above 1GHz.
5. All modes of operation were investigated, and the worst-case emissions are reported.

3.1.5 DEVIATION FROM TEST STANDARD

No deviation.



3.1.6 TEST SETUP

<Frequency Range 9KHz~30MHz >

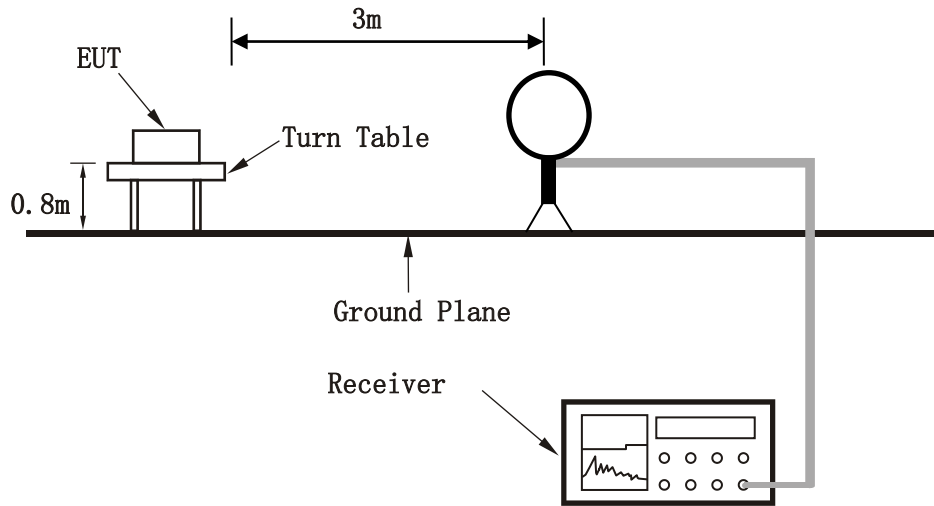

< Frequency Range 30MHz~1GHz >

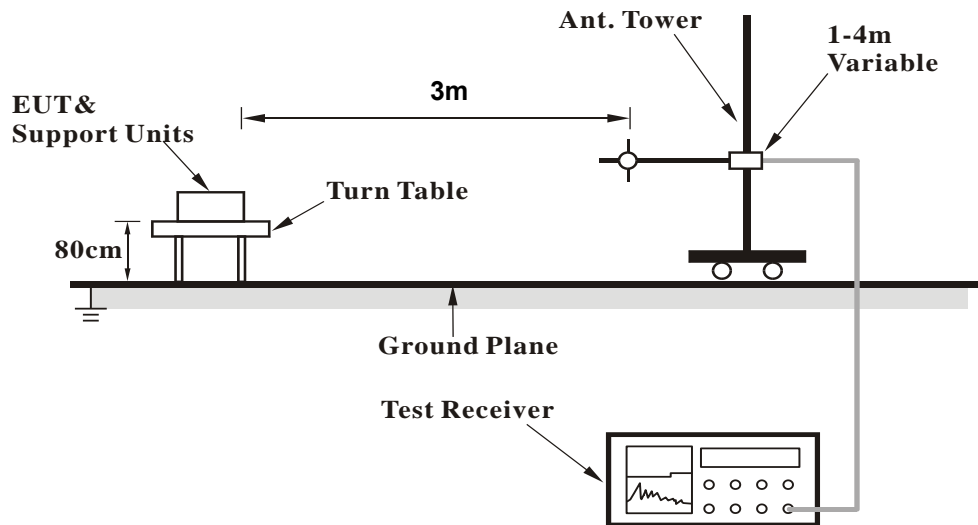



<Frequency Range above 1GHz>

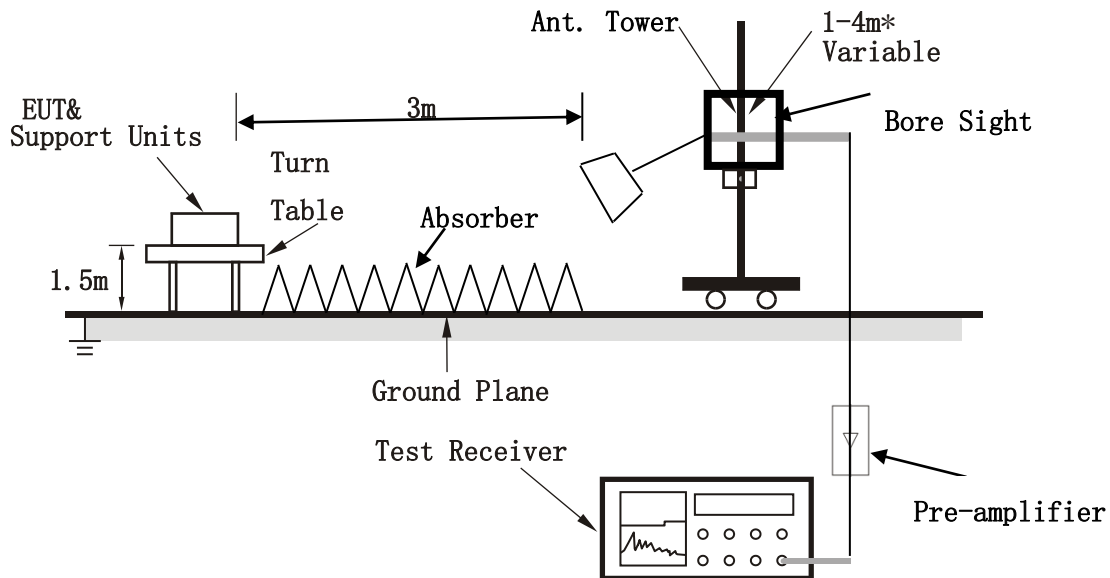

Note: Above 1G is a directional antenna

Depending on the EUT height and the antenna 3dB beamwidth both, refer to section 7.3 of CISPR 16-2-3.

For the actual test configuration, please refer to the attached file (Test Setup Photo).

3.1.7 EUT OPERATING CONDITION

- Set the EUT under full load condition and placed it on a testing table.
- Set the transmitter part of EUT under transmission condition continuously at specific channel frequency.
- The necessary accessories enable the EUT in full functions.



3.1.8 TEST RESULTS

NOTE : The 9K~30MHz amplitude of spurious emissions attenuated more than 20 dB below the permissible value is not required in the report.

30 MHz – 1GHz data:

Band 2

802.11ac (80MHz):

CHANNEL	TX Channel 58	DETECTOR FUNCTION	Quasi-Peak (QP)
FREQUENCY RANGE	30MHz ~ 1GHz		

ANTENNA POLARITY & TEST DISTANCE: HORIZONTAL AT 3 M										
FREQ. (MHz)	EMISSION LEVEL (dBuV/m)	READ LEVEL (dBuV)	LIMIT (dBuV/m)	MARGIN (dB)	ANTENNA FACTOR (dB /m)	CABLE LOSS (dB)	PREAMP FACTOR (dB)	ANTENNA HEIGHT (cm)	TABLE ANGLE (Degree)	REMARK
30.97	23.87	36.55	40	-16.13	24.61	0.14	37.43	100	0	Peak
47.52	20.94	42.48	40	-19.06	15.53	0.29	37.36	100	0	Peak
102.53	18.05	39.67	43.5	-25.45	14.71	0.55	36.88	100	0	Peak
198.01	19.72	38.8	43.5	-23.78	16.5	0.99	36.57	100	0	Peak
342.14	23.25	37.89	46	-22.75	20.57	1.42	36.63	100	0	Peak
781.64	28.31	34.29	46	-17.69	28.97	2.56	37.51	100	0	Peak

REMARKS:

1. Emission level (dBuV/m) = Read level (dBuV) + Correction Factor (dB/m).
2. Correction Factor (dB/m) = Antenna Factor (dB/m) + Cable Factor (dB).
3. The other emission levels were very low against the limit.
4. Margin value = Emission level – Limit value.

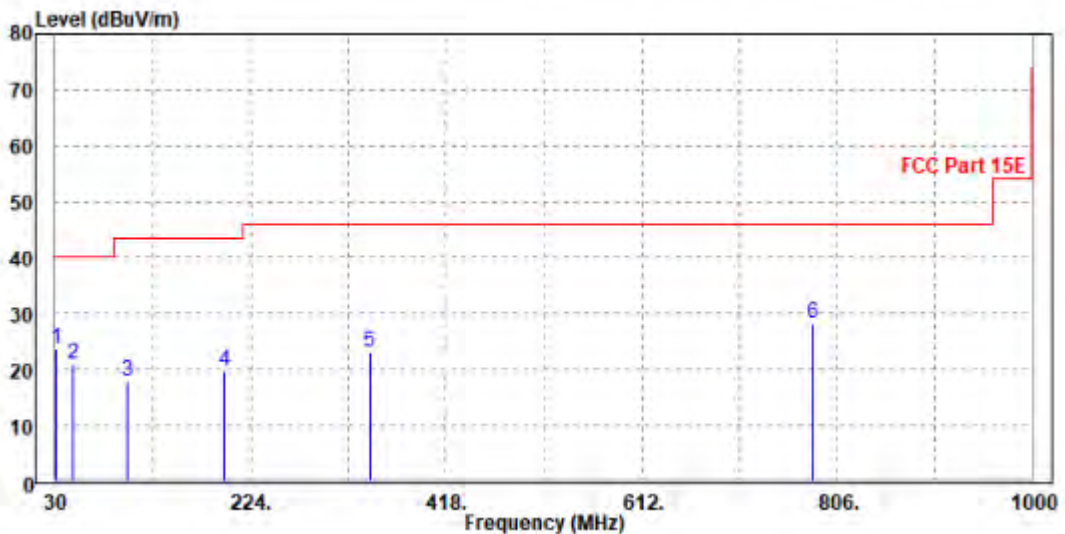



CHANNEL	Channel 58	DETECTOR FUNCTION	Quasi-Peak (QP)
FREQUENCY RANGE	30MHz ~ 1GHz		

ANTENNA POLARITY & TEST DISTANCE: VERTICAL AT 3 M										
FREQ. (MHz)	EMISSION LEVEL (dBuV/m)	READ LEVEL (dBuV)	LIMIT (dBuV/m)	MARGIN (dB)	ANTENNA FACTOR (dB /m)	CABLE LOSS (dB)	PREAMP FACTOR (dB)	ANTENNA HEIGHT (cm)	TABLE ANGLE (Degree)	REMARK
30	22.83	35.14	40	-17.17	25	0.13	37.44	100	360	Peak
63.16	25.59	48.14	40	-14.41	14.47	0.33	37.35	100	360	Peak
125.45	20.7	43.7	43.5	-22.8	13.15	0.66	36.81	100	360	Peak
234.15	23.83	41.44	46	-22.17	17.86	1.1	36.57	100	360	Peak
387.21	21.11	33.61	46	-24.89	22.62	1.53	36.65	100	360	Peak
824.09	26.72	32.18	46	-19.28	29.45	2.64	37.55	100	360	Peak

REMARKS:

1. Emission level (dBuV/m) = Read level (dBuV) + Correction Factor (dB/m).
2. Correction Factor (dB/m) = Antenna Factor (dB/m) + Cable Factor (dB).
3. The other emission levels were very low against the limit.
4. Margin value = Emission level – Limit value.

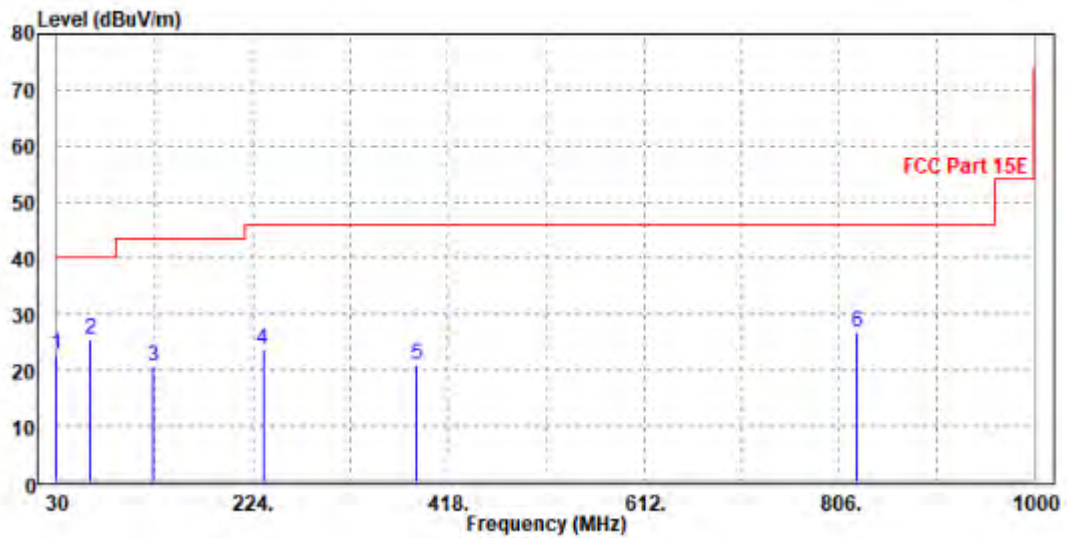



ABOVE 1GHz WORST-CASE DATA:

Note: For higher frequency, the emission is too low to be detected.

Band 1
802.11a

CHANNEL	TX Channel 36	DETECTOR FUNCTION	Peak (PK)
FREQUENCY RANGE	1GHz ~ 40GHz		Average (AV)

ANTENNA POLARITY & TEST DISTANCE: HORIZONTAL AT 3 M										
FREQ. (MHz)	EMISSION LEVEL (dBuV/m)	READ LEVEL (dBuV)	LIMIT (dBuV/m)	MARGIN (dB)	ANTENNA FACTOR (dB /m)	CABLE LOSS (dB)	PREAMP FACTOR (dB)	ANTENNA HEIGHT (cm)	TABLE ANGLE (Degree)	REMARK
5150	52.60	53.82	74.00	-21.40	34.20	11.17	46.59	100	215	Peak
5150	46.06	47.28	54.00	-7.94	34.20	11.17	46.59	100	215	Average
5180	100.49	101.62	/	/	34.26	11.20	46.59	100	215	Peak
5180	92.59	93.72	/	/	34.26	11.20	46.59	100	215	Average
5350	53.76	54.61	74.00	-20.24	34.30	11.39	46.54	100	215	Peak
5350	46.02	46.87	54.00	-7.98	34.30	11.39	46.54	100	215	Average
ANTENNA POLARITY & TEST DISTANCE: VERTICAL AT 3 M										
FREQ. (MHz)	EMISSION LEVEL (dBuV/m)	READ LEVEL (dBuV)	LIMIT (dBuV/m)	MARGIN (dB)	ANTENNA FACTOR (dB /m)	CABLE LOSS (dB)	PREAMP FACTOR (dB)	ANTENNA HEIGHT (cm)	TABLE ANGLE (Degree)	REMARK
5150	54.21	55.63	74.00	-19.79	34.00	11.17	46.59	100	345	Peak
5150	45.61	47.03	54.00	-8.39	34.00	11.17	46.59	100	345	Average
5180	93.90	95.35	/	/	33.94	11.20	46.59	100	345	Peak
5180	87.11	88.56	/	/	33.94	11.20	46.59	100	345	Average
5350	55.26	55.61	74.00	-18.74	34.80	11.39	46.54	100	345	Peak
5350	46.63	46.98	54.00	-7.37	34.80	11.39	46.54	100	345	Average

REMARKS:

- Emission Level = Read Level+ Antenna Factor + Cable Loss- Preamp Factor
Margin value = Emission level – Limit value.
- 5180MHz: Fundamental frequency.



CHANNEL	TX Channel 40	DETECTOR FUNCTION	Peak (PK)
FREQUENCY RANGE	1GHz ~ 40GHz		Average (AV)

ANTENNA POLARITY & TEST DISTANCE: HORIZONTAL AT 3 M

FREQ. (MHz)	EMISSION LEVEL (dBuV/m)	READ LEVEL (dBuV)	LIMIT (dBuV/m)	MARGIN (dB)	ANTENNA FACTOR (dB /m)	CABLE LOSS (dB)	PREAMP FACTOR (dB)	ANTENNA HEIGHT (cm)	TABLE ANGLE (Degree)	REMARK
5150	53.55	54.77	74.00	-20.45	34.20	11.17	46.59	100	215	Peak
5150	45.92	47.14	54.00	-8.08	34.20	11.17	46.59	100	215	Average
5200	100.17	101.23	/	/	34.30	11.22	46.58	100	215	Peak
5200	92.15	93.21	/	/	34.30	11.22	46.58	100	215	Average
5350	52.59	53.44	74.00	-21.41	34.30	11.39	46.54	100	215	Peak
5350	45.82	46.67	54.00	-8.18	34.30	11.39	46.54	100	215	Average

ANTENNA POLARITY & TEST DISTANCE: VERTICAL AT 3 M

FREQ. (MHz)	EMISSION LEVEL (dBuV/m)	READ LEVEL (dBuV)	LIMIT (dBuV/m)	MARGIN (dB)	ANTENNA FACTOR (dB /m)	CABLE LOSS (dB)	PREAMP FACTOR (dB)	ANTENNA HEIGHT (cm)	TABLE ANGLE (Degree)	REMARK
5150	52.42	53.84	74.00	-21.58	34.00	11.17	46.59	100	345	Peak
5150	45.74	47.16	54.00	-8.26	34.00	11.17	46.59	100	345	Average
5200	94.95	96.41	/	/	33.90	11.22	46.58	100	345	Peak
5200	85.11	86.57	/	/	33.90	11.22	46.58	100	345	Average
5350	54.17	54.52	74.00	-19.83	34.80	11.39	46.54	100	345	Peak
5350	46.43	46.78	54.00	-7.57	34.80	11.39	46.54	100	345	Average

REMARKS:

1. Emission Level = Read Level+ Antenna Factor + Cable Loss- Preamp Factor
Margin value = Emission level – Limit value.
2. 5200MHz: Fundamental frequency.



CHANNEL	TX Channel 48	DETECTOR FUNCTION	Peak (PK)
FREQUENCY RANGE	1GHz ~ 40GHz		Average (AV)

ANTENNA POLARITY & TEST DISTANCE: HORIZONTAL AT 3 M										
FREQ. (MHz)	EMISSION LEVEL (dBuV/m)	READ LEVEL (dBuV)	LIMIT (dBuV/m)	MARGIN (dB)	ANTENNA FACTOR (dB /m)	CABLE LOSS (dB)	PREAMP FACTOR (dB)	ANTENNA HEIGHT (cm)	TABLE ANGLE (Degree)	REMARK
5150	52.73	53.95	74.00	-21.27	34.20	11.17	46.59	100	215	Peak
5150	45.57	46.79	54.00	-8.43	34.20	11.17	46.59	100	215	Average
5240	100.88	101.72	/	/	34.46	11.27	46.57	100	215	Peak
5240	92.72	93.56	/	/	34.46	11.27	46.57	100	215	Average
5350	53.27	54.12	74.00	-20.73	34.30	11.39	46.54	100	215	Peak
5350	46.78	47.63	54.00	-7.22	34.30	11.39	46.54	100	215	Average
ANTENNA POLARITY & TEST DISTANCE: VERTICAL AT 3 M										
FREQ. (MHz)	EMISSION LEVEL (dBuV/m)	READ LEVEL (dBuV)	LIMIT (dBuV/m)	MARGIN (dB)	ANTENNA FACTOR (dB /m)	CABLE LOSS (dB)	PREAMP FACTOR (dB)	ANTENNA HEIGHT (cm)	TABLE ANGLE (Degree)	REMARK
5150	52.37	53.79	74.00	-21.63	34.00	11.17	46.59	100	345	Peak
5150	45.12	46.54	54.00	-8.88	34.00	11.17	46.59	100	345	Average
5240	94.29	95.61	/	/	33.98	11.27	46.57	100	345	Peak
5240	87.39	88.71	/	/	33.98	11.27	46.57	100	345	Average
5350	54.50	54.85	74.00	-19.50	34.80	11.39	46.54	100	345	Peak
5350	46.70	47.05	54.00	-7.30	34.80	11.39	46.54	100	345	Average

REMARKS:

- Emission Level = Read Level+ Antenna Factor + Cable Loss- Preamp Factor
Margin value = Emission level – Limit value.
- 5240MHz: Fundamental frequency.



802.11n (20MHz)

CHANNEL	TX Channel 36	DETECTOR FUNCTION	Peak (PK)
FREQUENCY RANGE	1GHz ~ 40GHz		Average (AV)

ANTENNA POLARITY & TEST DISTANCE: HORIZONTAL AT 3 M										
FREQ. (MHz)	EMISSION LEVEL (dBuV/m)	READ LEVEL (dBuV)	LIMIT (dBuV/m)	MARGIN (dB)	ANTENNA FACTOR (dB /m)	CABLE LOSS (dB)	PREAMP FACTOR (dB)	ANTENNA HEIGHT (cm)	TABLE ANGLE (Degree)	REMARK
5150	53.60	54.82	74.00	-20.40	34.20	11.17	46.59	100	215	Peak
5150	47.04	48.26	54.00	-6.96	34.20	11.17	46.59	100	215	Average
5180	99.75	100.88	/	/	34.26	11.20	46.59	100	215	Peak
5180	93.35	94.48	/	/	34.26	11.20	46.59	100	215	Average
5350	53.64	54.49	74.00	-20.36	34.30	11.39	46.54	100	215	Peak
5350	46.18	47.03	54.00	-7.82	34.30	11.39	46.54	100	215	Average

ANTENNA POLARITY & TEST DISTANCE: VERTICAL AT 3 M										
FREQ. (MHz)	EMISSION LEVEL (dBuV/m)	READ LEVEL (dBuV)	LIMIT (dBuV/m)	MARGIN (dB)	ANTENNA FACTOR (dB /m)	CABLE LOSS (dB)	PREAMP FACTOR (dB)	ANTENNA HEIGHT (cm)	TABLE ANGLE (Degree)	REMARK
5150	52.44	53.86	74.00	-21.56	34.00	11.17	46.59	100	345	Peak
5150	45.92	47.34	54.00	-8.08	34.00	11.17	46.59	100	345	Average
5180	93.34	94.79	/	/	33.94	11.20	46.59	100	345	Peak
5180	85.88	87.33	/	/	33.94	11.20	46.59	100	345	Average
5350	53.36	53.71	74.00	-20.64	34.80	11.39	46.54	100	345	Peak
5350	46.80	47.15	54.00	-7.20	34.80	11.39	46.54	100	345	Average

REMARKS:

- Emission Level = Read Level+ Antenna Factor + Cable Loss- Preamp Factor
Margin value = Emission level – Limit value.
- 5180MHz: Fundamental frequency.



CHANNEL	TX Channel 40	DETECTOR FUNCTION	Peak (PK)
FREQUENCY RANGE	1GHz ~ 40GHz		Average (AV)

ANTENNA POLARITY & TEST DISTANCE: HORIZONTAL AT 3 M										
FREQ. (MHz)	EMISSION LEVEL (dBuV/m)	READ LEVEL (dBuV)	LIMIT (dBuV/m)	MARGIN (dB)	ANTENNA FACTOR (dB /m)	CABLE LOSS (dB)	PREAMP FACTOR (dB)	ANTENNA HEIGHT (cm)	TABLE ANGLE (Degree)	REMARK
5150	53.54	54.76	74.00	-20.46	34.20	11.17	46.59	100	215	Peak
5150	46.07	47.29	54.00	-7.93	34.20	11.17	46.59	100	215	Average
5200	100.07	101.13	/	/	34.30	11.22	46.58	100	215	Peak
5200	92.36	93.42	/	/	34.30	11.22	46.58	100	215	Average
5350	52.92	53.77	74.00	-21.08	34.30	11.39	46.54	100	215	Peak
5350	46.09	46.94	54.00	-7.91	34.30	11.39	46.54	100	215	Average
ANTENNA POLARITY & TEST DISTANCE: VERTICAL AT 3 M										
FREQ. (MHz)	EMISSION LEVEL (dBuV/m)	READ LEVEL (dBuV)	LIMIT (dBuV/m)	MARGIN (dB)	ANTENNA FACTOR (dB /m)	CABLE LOSS (dB)	PREAMP FACTOR (dB)	ANTENNA HEIGHT (cm)	TABLE ANGLE (Degree)	REMARK
5150	54.24	55.66	74.00	-19.76	34.00	11.17	46.59	100	345	Peak
5150	45.79	47.21	54.00	-8.21	34.00	11.17	46.59	100	345	Average
5200	92.30	93.76	/	/	33.90	11.22	46.58	100	345	Peak
5200	84.60	86.06	/	/	33.90	11.22	46.58	100	345	Average
5350	52.57	52.92	74.00	-21.43	34.80	11.39	46.54	100	345	Peak
5350	46.39	46.74	54.00	-7.61	34.80	11.39	46.54	100	345	Average

REMARKS:

- Emission Level = Read Level+ Antenna Factor + Cable Loss- Preamp Factor
Margin value = Emission level – Limit value.
- 5200MHz: Fundamental frequency.



CHANNEL	TX Channel 48	DETECTOR FUNCTION	Peak (PK)
FREQUENCY RANGE	1GHz ~ 40GHz		Average (AV)

ANTENNA POLARITY & TEST DISTANCE: HORIZONTAL AT 3 M

FREQ. (MHz)	EMISSION LEVEL (dBuV/m)	READ LEVEL (dBuV)	LIMIT (dBuV/m)	MARGIN (dB)	ANTENNA FACTOR (dB /m)	CABLE LOSS (dB)	PREAMP FACTOR (dB)	ANTENNA HEIGHT (cm)	TABLE ANGLE (Degree)	REMARK
5150	54.32	55.54	74.00	-19.68	34.20	11.17	46.59	100	215	Peak
5150	45.45	46.67	54.00	-8.55	34.20	11.17	46.59	100	215	Average
5240	99.58	100.42	/	/	34.46	11.27	46.57	100	215	Peak
5240	92.80	93.64	/	/	34.46	11.27	46.57	100	215	Average
5350	53.56	54.41	74.00	-20.44	34.30	11.39	46.54	100	215	Peak
5350	47.01	47.86	54.00	-6.99	34.30	11.39	46.54	100	215	Average

ANTENNA POLARITY & TEST DISTANCE: VERTICAL AT 3 M

FREQ. (MHz)	EMISSION LEVEL (dBuV/m)	READ LEVEL (dBuV)	LIMIT (dBuV/m)	MARGIN (dB)	ANTENNA FACTOR (dB /m)	CABLE LOSS (dB)	PREAMP FACTOR (dB)	ANTENNA HEIGHT (cm)	TABLE ANGLE (Degree)	REMARK
5150	52.19	53.61	74.00	-21.81	34.00	11.17	46.59	100	345	Peak
5150	45.43	46.85	54.00	-8.57	34.00	11.17	46.59	100	345	Average
5240	92.72	94.04	/	/	33.98	11.27	46.57	100	345	Peak
5240	85.11	86.43	/	/	33.98	11.27	46.57	100	345	Average
5350	53.77	54.12	74.00	-20.23	34.80	11.39	46.54	100	345	Peak
5350	46.86	47.21	54.00	-7.14	34.80	11.39	46.54	100	345	Average

REMARKS:

- Emission Level = Read Level+ Antenna Factor + Cable Loss- Preamp Factor
Margin value = Emission level – Limit value.
- 5240MHz: Fundamental frequency.



802.11n (40MHz)

CHANNEL	TX Channel 38	DETECTOR FUNCTION	Peak (PK)
FREQUENCY RANGE	1GHz ~ 40GHz		Average (AV)

ANTENNA POLARITY & TEST DISTANCE: HORIZONTAL AT 3 M										
FREQ. (MHz)	EMISSION LEVEL (dBuV/m)	READ LEVEL (dBuV)	LIMIT (dBuV/m)	MARGIN (dB)	ANTENNA FACTOR (dB /m)	CABLE LOSS (dB)	PREAMP FACTOR (dB)	ANTENNA HEIGHT (cm)	TABLE ANGLE (Degree)	REMARK
5150	52.42	53.64	74.00	-21.58	34.20	11.17	46.59	100	215	Peak
5150	46.90	48.12	54.00	-7.10	34.20	11.17	46.59	100	215	Average
5190	95.65	96.74	/	/	34.28	11.21	46.58	100	215	Peak
5190	89.84	90.93	/	/	34.28	11.21	46.58	100	215	Average
5350	51.56	52.41	74.00	-22.44	34.30	11.39	46.54	100	215	Peak
5350	46.06	46.91	54.00	-7.94	34.30	11.39	46.54	100	215	Average

ANTENNA POLARITY & TEST DISTANCE: VERTICAL AT 3 M										
FREQ. (MHz)	EMISSION LEVEL (dBuV/m)	READ LEVEL (dBuV)	LIMIT (dBuV/m)	MARGIN (dB)	ANTENNA FACTOR (dB /m)	CABLE LOSS (dB)	PREAMP FACTOR (dB)	ANTENNA HEIGHT (cm)	TABLE ANGLE (Degree)	REMARK
5150	51.96	53.38	74.00	-22.04	34.00	11.17	46.59	100	345	Peak
5150	46.02	47.44	54.00	-7.98	34.00	11.17	46.59	100	345	Average
5190	89.59	91.04	/	/	33.92	11.21	46.58	100	345	Peak
5190	82.85	84.30	/	/	33.92	11.21	46.58	100	345	Average
5350	51.89	52.24	74.00	-22.11	34.80	11.39	46.54	100	345	Peak
5350	46.62	46.97	54.00	-7.38	34.80	11.39	46.54	100	345	Average

REMARKS:

- Emission Level = Read Level+ Antenna Factor + Cable Loss- Preamp Factor
Margin value = Emission level – Limit value.
- 5190MHz: Fundamental frequency.



CHANNEL	TX Channel 46	DETECTOR FUNCTION	Peak (PK)
FREQUENCY RANGE	1GHz ~ 40GHz		Average (AV)

ANTENNA POLARITY & TEST DISTANCE: HORIZONTAL AT 3 M

FREQ. (MHz)	EMISSION LEVEL (dBuV/m)	READ LEVEL (dBuV)	LIMIT (dBuV/m)	MARGIN (dB)	ANTENNA FACTOR (dB /m)	CABLE LOSS (dB)	PREAMP FACTOR (dB)	ANTENNA HEIGHT (cm)	TABLE ANGLE (Degree)	REMARK
5150	51.67	52.89	74.00	-22.33	34.20	11.17	46.59	100	215	Peak
5150	45.36	46.58	54.00	-8.64	34.20	11.17	46.59	100	215	Average
5230	96.43	97.32	/	/	34.42	11.26	46.57	100	215	Peak
5230	90.53	91.42	/	/	34.42	11.26	46.57	100	215	Average
5350	53.02	53.87	74.00	-20.98	34.30	11.39	46.54	100	215	Peak
5350	47.91	48.76	54.00	-6.09	34.30	11.39	46.54	100	215	Average

ANTENNA POLARITY & TEST DISTANCE: VERTICAL AT 3 M

FREQ. (MHz)	EMISSION LEVEL (dBuV/m)	READ LEVEL (dBuV)	LIMIT (dBuV/m)	MARGIN (dB)	ANTENNA FACTOR (dB /m)	CABLE LOSS (dB)	PREAMP FACTOR (dB)	ANTENNA HEIGHT (cm)	TABLE ANGLE (Degree)	REMARK
5150	51.83	53.25	74.00	-22.17	34.00	11.17	46.59	100	345	Peak
5150	45.34	46.76	54.00	-8.66	34.00	11.17	46.59	100	345	Average
5230	90.26	91.61	/	/	33.96	11.26	46.57	100	345	Peak
5230	83.63	84.98	/	/	33.96	11.26	46.57	100	345	Average
5350	53.73	54.08	74.00	-20.27	34.80	11.39	46.54	100	345	Peak
5350	46.70	47.05	54.00	-7.30	34.80	11.39	46.54	100	345	Average

REMARKS:

- Emission Level = Read Level+ Antenna Factor + Cable Loss- Preamp Factor
Margin value = Emission level – Limit value.
- 5230MHz: Fundamental frequency.



802.11ac (80MHz)

CHANNEL	TX Channel 42	DETECTOR FUNCTION	Peak (PK)
FREQUENCY RANGE	1GHz ~ 40GHz		Average (AV)

ANTENNA POLARITY & TEST DISTANCE: HORIZONTAL AT 3 M										
FREQ. (MHz)	EMISSION LEVEL (dBuV/m)	READ LEVEL (dBuV)	LIMIT (dBuV/m)	MARGIN (dB)	ANTENNA FACTOR (dB /m)	CABLE LOSS (dB)	PREAMP FACTOR (dB)	ANTENNA HEIGHT (cm)	TABLE ANGLE (Degree)	REMARK
5150	51.32	52.54	74.00	-22.68	34.20	11.17	46.59	100	215	Peak
5150	47.99	49.21	54.00	-6.01	34.20	11.17	46.59	100	215	Average
5210	93.19	94.19	/	/	34.34	11.24	46.58	100	215	Peak
5210	86.03	87.03	/	/	34.34	11.24	46.58	100	215	Average
5350	51.21	52.06	74.00	-22.79	34.30	11.39	46.54	100	215	Peak
5350	46.49	47.34	54.00	-7.51	34.30	11.39	46.54	100	215	Average

ANTENNA POLARITY & TEST DISTANCE: VERTICAL AT 3 M										
FREQ. (MHz)	EMISSION LEVEL (dBuV/m)	READ LEVEL (dBuV)	LIMIT (dBuV/m)	MARGIN (dB)	ANTENNA FACTOR (dB /m)	CABLE LOSS (dB)	PREAMP FACTOR (dB)	ANTENNA HEIGHT (cm)	TABLE ANGLE (Degree)	REMARK
5150	51.85	53.27	74.00	-22.15	34.00	11.17	46.59	100	345	Peak
5150	47.25	48.67	54.00	-6.75	34.00	11.17	46.59	100	345	Average
5210	84.15	85.57	/	/	33.92	11.24	46.58	100	345	Peak
5210	79.21	80.63	/	/	33.92	11.24	46.58	100	345	Average
5350	53.26	53.61	74.00	-20.74	34.80	11.39	46.54	100	345	Peak
5350	46.23	46.58	54.00	-7.77	34.80	11.39	46.54	100	345	Average

REMARKS:

- Emission Level = Read Level+ Antenna Factor + Cable Loss- Preamp Factor
Margin value = Emission level – Limit value.
- 5210MHz: Fundamental frequency.



802.11ac (80MHz)

Worst case harmonic:

CHANNEL	TX Channel 42	DETECTOR FUNCTION	Peak (PK)
FREQUENCY RANGE	1GHz ~ 40GHz		Average (AV)

ANTENNA POLARITY & TEST DISTANCE: HORIZONTAL AT 3 M

	Freq	Level	Read Level	Limit Line	Over Limit	Factor	Remark	Pol/Phase
	MHz	dBuV/m	dBuV	dBuV/m	dB	dB/m		
1	10420.000	52.05	44.72	74.00	-21.95	7.33	Peak	Horizontal
2	10420.000	44.09	36.76	54.00	-9.91	7.33	Average	Horizontal
3	PK15637.000	61.85	41.96	74.00	-12.15	19.89	Peak	Horizontal
4	PP15637.000	50.80	30.91	54.00	-3.20	19.89	Average	Horizontal

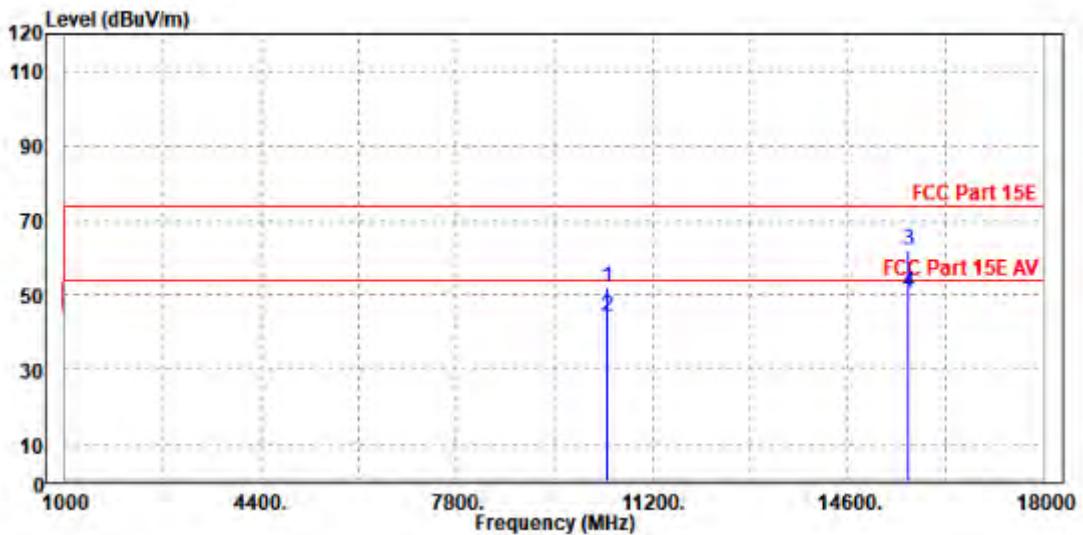



ANTENNA POLARITY & TEST DISTANCE: VERTICAL AT 3 M

	Freq	Level	Read Level	Limit Line	Over Limit	Factor	Remark	Pol/Phase
	MHz	dBuV/m	dBuV	dBuV/m	dB	dB/m		
1	10418.000	52.84	45.87	74.00	-21.16	6.97	Peak	Vertical
2	10418.000	44.12	37.15	54.00	-9.88	6.97	Average	Vertical
3	PK15630.000	61.49	41.92	74.00	-12.51	19.57	Peak	Vertical
4	PP15630.000	50.24	30.67	54.00	-3.76	19.57	Average	Vertical

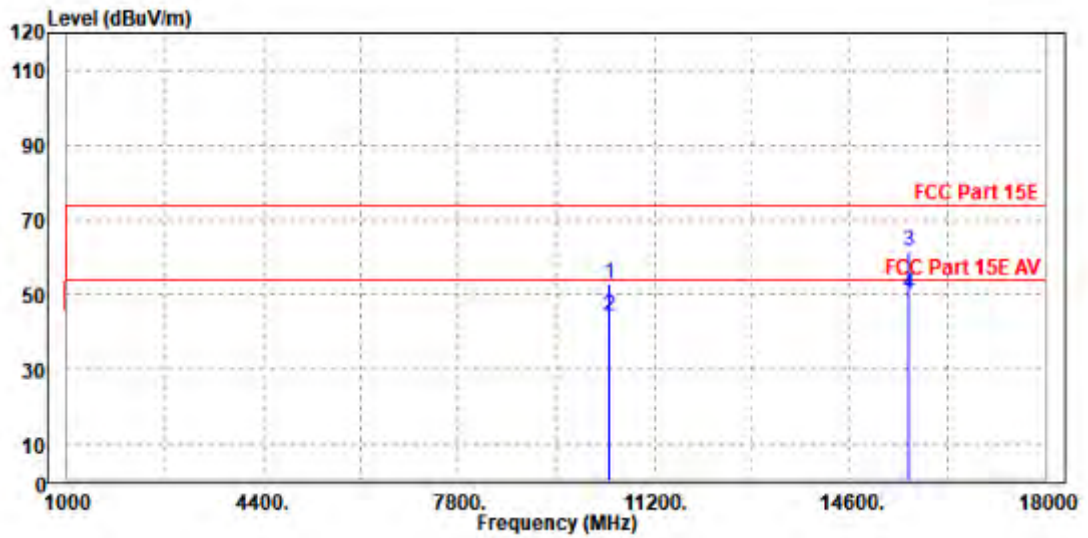

REMARKS:

1. Emission Level = Read Level+ Antenna Factor + Cable Loss- Preamp Factor
Margin value = Emission level – Limit value.
2. 5210MHz: Fundamental frequency.
3. For frequency above 18GHz, the emission was tested 20db below the limit so the data not recorded in the sheet.



Band 2
802.11a

CHANNEL	TX Channel 52	DETECTOR FUNCTION	Peak (PK)
FREQUENCY RANGE	1GHz ~ 40GHz		Average (AV)

ANTENNA POLARITY & TEST DISTANCE: HORIZONTAL AT 3 M

FREQ. (MHz)	EMISSION LEVEL (dBuV/m)	READ LEVEL (dBuV)	LIMIT (dBuV/m)	MARGIN (dB)	ANTENNA FACTOR (dB /m)	CABLE LOSS (dB)	PREAMP FACTOR (dB)	ANTENNA HEIGHT (cm)	TABLE ANGLE (Degree)	REMARK
5150	53.74	54.96	74.00	-20.26	34.20	11.17	46.59	100	215	Peak
5150	46.29	47.51	54.00	-7.71	34.20	11.17	46.59	100	215	Average
5260	99.72	100.54	/	/	34.46	11.29	46.57	100	215	Peak
5260	92.68	93.50	/	/	34.46	11.29	46.57	100	215	Average
5350	54.99	55.84	74.00	-19.01	34.30	11.39	46.54	100	215	Peak
5350	46.00	46.85	54.00	-8.00	34.30	11.39	46.54	100	215	Average

ANTENNA POLARITY & TEST DISTANCE: VERTICAL AT 3 M

FREQ. (MHz)	EMISSION LEVEL (dBuV/m)	READ LEVEL (dBuV)	LIMIT (dBuV/m)	MARGIN (dB)	ANTENNA FACTOR (dB /m)	CABLE LOSS (dB)	PREAMP FACTOR (dB)	ANTENNA HEIGHT (cm)	TABLE ANGLE (Degree)	REMARK
5150	51.43	52.85	74.00	-22.57	34.00	11.17	46.59	100	45	Peak
5150	45.77	47.19	54.00	-8.23	34.00	11.17	46.59	100	45	Average
5260	94.07	95.23	/	/	34.12	11.29	46.57	100	45	Peak
5260	86.50	87.66	/	/	34.12	11.29	46.57	100	45	Average
5350	53.27	53.62	74.00	-20.73	34.80	11.39	46.54	100	45	Peak
5350	46.19	46.54	54.00	-7.81	34.80	11.39	46.54	100	45	Average

REMARKS:

- Emission Level = Read Level+ Antenna Factor + Cable Loss- Preamp Factor
Margin value = Emission level – Limit value.
- 5260MHz: Fundamental frequency.



CHANNEL	TX Channel 60	DETECTOR FUNCTION	Peak (PK)
FREQUENCY RANGE	1GHz ~ 40GHz		Average (AV)

ANTENNA POLARITY & TEST DISTANCE: HORIZONTAL AT 3 M										
FREQ. (MHz)	EMISSION LEVEL (dBuV/m)	READ LEVEL (dBuV)	LIMIT (dBuV/m)	MARGIN (dB)	ANTENNA FACTOR (dB /m)	CABLE LOSS (dB)	PREAMP FACTOR (dB)	ANTENNA HEIGHT (cm)	TABLE ANGLE (Degree)	REMARK
5150	50.92	52.14	74.00	-23.08	34.20	11.17	46.59	100	205	Peak
5150	45.94	47.16	54.00	-8.06	34.20	11.17	46.59	100	205	Average
5300	99.70	100.62	/	/	34.30	11.34	46.56	100	205	Peak
5300	93.87	94.79	/	/	34.30	11.34	46.56	100	205	Average
5350	50.78	51.63	74.00	-23.22	34.30	11.39	46.54	100	205	Peak
5350	45.94	46.79	54.00	-8.06	34.30	11.39	46.54	100	205	Average

ANTENNA POLARITY & TEST DISTANCE: VERTICAL AT 3 M										
FREQ. (MHz)	EMISSION LEVEL (dBuV/m)	READ LEVEL (dBuV)	LIMIT (dBuV/m)	MARGIN (dB)	ANTENNA FACTOR (dB /m)	CABLE LOSS (dB)	PREAMP FACTOR (dB)	ANTENNA HEIGHT (cm)	TABLE ANGLE (Degree)	REMARK
5150	49.32	50.74	74.00	-24.68	34.00	11.17	46.59	100	55	Peak
5150	45.70	47.12	54.00	-8.30	34.00	11.17	46.59	100	55	Average
5300	93.88	94.50	/	/	34.60	11.34	46.56	100	55	Peak
5300	87.83	88.45	/	/	34.60	11.34	46.56	100	55	Average
5350	52.21	52.56	74.00	-21.79	34.80	11.39	46.54	100	55	Peak
5350	46.42	46.77	54.00	-7.58	34.80	11.39	46.54	100	55	Average

REMARKS:

- Emission Level = Read Level+ Antenna Factor + Cable Loss- Preamp Factor
Margin value = Emission level – Limit value.
- 5300MHz: Fundamental frequency.



CHANNEL	TX Channel 64	DETECTOR FUNCTION	Peak (PK)
FREQUENCY RANGE	1GHz ~ 40GHz		Average (AV)

ANTENNA POLARITY & TEST DISTANCE: HORIZONTAL AT 3 M										
FREQ. (MHz)	EMISSION LEVEL (dBuV/m)	READ LEVEL (dBuV)	LIMIT (dBuV/m)	MARGIN (dB)	ANTENNA FACTOR (dB /m)	CABLE LOSS (dB)	PREAMP FACTOR (dB)	ANTENNA HEIGHT (cm)	TABLE ANGLE (Degree)	REMARK
5150	52.28	53.50	74.00	-21.72	34.20	11.17	46.59	100	215	Peak
5150	45.90	47.12	54.00	-8.10	34.20	11.17	46.59	100	215	Average
5320	98.59	99.48	/	/	34.30	11.36	46.55	100	215	Peak
5320	93.17	94.06	/	/	34.30	11.36	46.55	100	215	Average
5350	51.79	52.64	74.00	-22.21	34.30	11.39	46.54	100	215	Peak
5350	46.37	47.22	54.00	-7.63	34.30	11.39	46.54	100	215	Average

ANTENNA POLARITY & TEST DISTANCE: VERTICAL AT 3 M										
FREQ. (MHz)	EMISSION LEVEL (dBuV/m)	READ LEVEL (dBuV)	LIMIT (dBuV/m)	MARGIN (dB)	ANTENNA FACTOR (dB /m)	CABLE LOSS (dB)	PREAMP FACTOR (dB)	ANTENNA HEIGHT (cm)	TABLE ANGLE (Degree)	REMARK
5150	50.43	51.85	74.00	-23.57	34.00	11.17	46.59	100	55	Peak
5150	45.64	47.06	54.00	-8.36	34.00	11.17	46.59	100	55	Average
5320	95.59	96.10	/	/	34.68	11.36	46.55	100	55	Peak
5320	89.66	90.17	/	/	34.68	11.36	46.55	100	55	Average
5350	52.67	53.02	74.00	-21.33	34.80	11.39	46.54	100	55	Peak
5350	46.58	46.93	54.00	-7.42	34.80	11.39	46.54	100	55	Average

REMARKS:

- Emission Level = Read Level+ Antenna Factor + Cable Loss- Preamp Factor
Margin value = Emission level – Limit value.
- 5320MHz: Fundamental frequency.



802.11n (20MHz)

CHANNEL	TX Channel 52	DETECTOR FUNCTION	Peak (PK)
FREQUENCY RANGE	1GHz ~ 40GHz		Average (AV)

ANTENNA POLARITY & TEST DISTANCE: HORIZONTAL AT 3 M										
FREQ. (MHz)	EMISSION LEVEL (dBuV/m)	READ LEVEL (dBuV)	LIMIT (dBuV/m)	MARGIN (dB)	ANTENNA FACTOR (dB /m)	CABLE LOSS (dB)	PREAMP FACTOR (dB)	ANTENNA HEIGHT (cm)	TABLE ANGLE (Degree)	REMARK
5150	51.15	52.37	74.00	-22.85	34.20	11.17	46.59	100	205	Peak
5150	45.58	46.80	54.00	-8.42	34.20	11.17	46.59	100	205	Average
5260	98.28	99.10	/	/	34.46	11.29	46.57	100	205	Peak
5260	92.52	93.34	/	/	34.46	11.29	46.57	100	205	Average
5350	51.94	52.79	74.00	-22.06	34.30	11.39	46.54	100	205	Peak
5350	46.12	46.97	54.00	-7.88	34.30	11.39	46.54	100	205	Average

ANTENNA POLARITY & TEST DISTANCE: VERTICAL AT 3 M										
FREQ. (MHz)	EMISSION LEVEL (dBuV/m)	READ LEVEL (dBuV)	LIMIT (dBuV/m)	MARGIN (dB)	ANTENNA FACTOR (dB /m)	CABLE LOSS (dB)	PREAMP FACTOR (dB)	ANTENNA HEIGHT (cm)	TABLE ANGLE (Degree)	REMARK
5150	50.77	52.19	74.00	-23.23	34.00	11.17	46.59	100	35	Peak
5150	45.49	46.91	54.00	-8.51	34.00	11.17	46.59	100	35	Average
5260	91.70	92.86	/	/	34.12	11.29	46.57	100	35	Peak
5260	85.90	87.06	/	/	34.12	11.29	46.57	100	35	Average
5350	51.75	52.10	74.00	-22.25	34.80	11.39	46.54	100	35	Peak
5350	46.43	46.78	54.00	-7.57	34.80	11.39	46.54	100	35	Average

REMARKS:

- Emission Level = Read Level+ Antenna Factor + Cable Loss- Preamp Factor
Margin value = Emission level – Limit value.
- 5260MHz: Fundamental frequency.



CHANNEL	TX Channel 60	DETECTOR FUNCTION	Peak (PK)
FREQUENCY RANGE	1GHz ~ 40GHz		Average (AV)

ANTENNA POLARITY & TEST DISTANCE: HORIZONTAL AT 3 M										
FREQ. (MHz)	EMISSION LEVEL (dBuV/m)	READ LEVEL (dBuV)	LIMIT (dBuV/m)	MARGIN (dB)	ANTENNA FACTOR (dB /m)	CABLE LOSS (dB)	PREAMP FACTOR (dB)	ANTENNA HEIGHT (cm)	TABLE ANGLE (Degree)	REMARK
5150	52.11	53.33	74.00	-21.89	34.20	11.17	46.59	100	315	Peak
5150	45.75	46.97	54.00	-8.25	34.20	11.17	46.59	100	315	Average
5300	98.83	99.75	/	/	34.30	11.34	46.56	100	315	Peak
5300	93.63	94.55	/	/	34.30	11.34	46.56	100	315	Average
5350	50.62	51.47	74.00	-23.38	34.30	11.39	46.54	100	315	Peak
5350	46.14	46.99	54.00	-7.86	34.30	11.39	46.54	100	315	Average

ANTENNA POLARITY & TEST DISTANCE: VERTICAL AT 3 M										
FREQ. (MHz)	EMISSION LEVEL (dBuV/m)	READ LEVEL (dBuV)	LIMIT (dBuV/m)	MARGIN (dB)	ANTENNA FACTOR (dB /m)	CABLE LOSS (dB)	PREAMP FACTOR (dB)	ANTENNA HEIGHT (cm)	TABLE ANGLE (Degree)	REMARK
5150	52.55	53.97	74.00	-21.45	34.00	11.17	46.59	100	45	Peak
5150	45.39	46.81	54.00	-8.61	34.00	11.17	46.59	100	45	Average
5300	93.44	94.06	/	/	34.60	11.34	46.56	100	45	Peak
5300	88.15	88.77	/	/	34.60	11.34	46.56	100	45	Average
5350	53.38	53.73	74.00	-20.62	34.80	11.39	46.54	100	45	Peak
5350	46.40	46.75	54.00	-7.60	34.80	11.39	46.54	100	45	Average

REMARKS:

1. Emission Level = Read Level+ Antenna Factor + Cable Loss- Preamp Factor
Margin value = Emission level – Limit value.
2. 5300MHz: Fundamental frequency.



CHANNEL	TX Channel 64	DETECTOR FUNCTION	Peak (PK)
FREQUENCY RANGE	1GHz ~ 40GHz		Average (AV)

ANTENNA POLARITY & TEST DISTANCE: HORIZONTAL AT 3 M

FREQ. (MHz)	EMISSION LEVEL (dBuV/m)	READ LEVEL (dBuV)	LIMIT (dBuV/m)	MARGIN (dB)	ANTENNA FACTOR (dB /m)	CABLE LOSS (dB)	PREAMP FACTOR (dB)	ANTENNA HEIGHT (cm)	TABLE ANGLE (Degree)	REMARK
5150	52.06	53.28	74.00	-21.94	34.20	11.17	46.59	100	315	Peak
5150	45.86	47.08	54.00	-8.14	34.20	11.17	46.59	100	315	Average
5320	98.96	99.85	/	/	34.30	11.36	46.55	100	315	Peak
5320	92.70	93.59	/	/	34.30	11.36	46.55	100	315	Average
5350	52.79	53.64	74.00	-21.21	34.30	11.39	46.54	100	315	Peak
5350	46.29	47.14	54.00	-7.71	34.30	11.39	46.54	100	315	Average

ANTENNA POLARITY & TEST DISTANCE: VERTICAL AT 3 M

FREQ. (MHz)	EMISSION LEVEL (dBuV/m)	READ LEVEL (dBuV)	LIMIT (dBuV/m)	MARGIN (dB)	ANTENNA FACTOR (dB /m)	CABLE LOSS (dB)	PREAMP FACTOR (dB)	ANTENNA HEIGHT (cm)	TABLE ANGLE (Degree)	REMARK
5150	50.53	51.95	74.00	-23.47	34.00	11.17	46.59	100	55	Peak
5150	45.33	46.75	54.00	-8.67	34.00	11.17	46.59	100	55	Average
5320	94.63	95.14	/	/	34.68	11.36	46.55	100	55	Peak
5320	88.96	89.47	/	/	34.68	11.36	46.55	100	55	Average
5350	51.06	51.41	74.00	-22.94	34.80	11.39	46.54	100	55	Peak
5350	46.74	47.09	54.00	-7.26	34.80	11.39	46.54	100	55	Average

REMARKS:

- Emission Level = Read Level+ Antenna Factor + Cable Loss- Preamp Factor
Margin value = Emission level – Limit value.
- 5320MHz: Fundamental frequency.



802.11n (40MHz)

CHANNEL	TX Channel 54	DETECTOR FUNCTION	Peak (PK)
FREQUENCY RANGE	1GHz ~ 40GHz		Average (AV)

ANTENNA POLARITY & TEST DISTANCE: HORIZONTAL AT 3 M										
FREQ. (MHz)	EMISSION LEVEL (dBuV/m)	READ LEVEL (dBuV)	LIMIT (dBuV/m)	MARGIN (dB)	ANTENNA FACTOR (dB /m)	CABLE LOSS (dB)	PREAMP FACTOR (dB)	ANTENNA HEIGHT (cm)	TABLE ANGLE (Degree)	REMARK
5150	51.46	52.68	74.00	-22.54	34.20	11.17	46.59	100	320	Peak
5150	46.22	47.44	54.00	-7.78	34.20	11.17	46.59	100	320	Average
5270	95.66	96.50	/	/	34.42	11.30	46.56	100	320	Peak
5270	90.00	90.84	/	/	34.42	11.30	46.56	100	320	Average
5350	51.73	52.58	74.00	-22.27	34.30	11.39	46.54	100	320	Peak
5350	46.42	47.27	54.00	-7.58	34.30	11.39	46.54	100	320	Average

ANTENNA POLARITY & TEST DISTANCE: VERTICAL AT 3 M										
FREQ. (MHz)	EMISSION LEVEL (dBuV/m)	READ LEVEL (dBuV)	LIMIT (dBuV/m)	MARGIN (dB)	ANTENNA FACTOR (dB /m)	CABLE LOSS (dB)	PREAMP FACTOR (dB)	ANTENNA HEIGHT (cm)	TABLE ANGLE (Degree)	REMARK
5150	52.46	53.88	74.00	-21.54	34.00	11.17	46.59	100	40	Peak
5150	46.25	47.67	54.00	-7.75	34.00	11.17	46.59	100	40	Average
5270	89.99	91.01	/	/	34.24	11.30	46.56	100	40	Peak
5270	84.32	85.34	/	/	34.24	11.30	46.56	100	40	Average
5350	52.86	53.21	74.00	-21.14	34.80	11.39	46.54	100	40	Peak
5350	46.85	47.20	54.00	-7.15	34.80	11.39	46.54	100	40	Average

REMARKS:

1. Emission Level = Read Level+ Antenna Factor + Cable Loss- Preamp Factor
Margin value = Emission level – Limit value.
2. 5270MHz: Fundamental frequency.



CHANNEL	TX Channel 62	DETECTOR FUNCTION	Peak (PK)
FREQUENCY RANGE	1GHz ~ 40GHz		Average (AV)

ANTENNA POLARITY & TEST DISTANCE: HORIZONTAL AT 3 M										
FREQ. (MHz)	EMISSION LEVEL (dBuV/m)	READ LEVEL (dBuV)	LIMIT (dBuV/m)	MARGIN (dB)	ANTENNA FACTOR (dB /m)	CABLE LOSS (dB)	PREAMP FACTOR (dB)	ANTENNA HEIGHT (cm)	TABLE ANGLE (Degree)	REMARK
5150	53.05	54.27	74.00	-20.95	34.20	11.17	46.59	100	320	Peak
5150	46.18	47.40	54.00	-7.82	34.20	11.17	46.59	100	320	Average
5310	96.75	97.65	/	/	34.30	11.35	46.55	100	320	Peak
5310	90.46	91.36	/	/	34.30	11.35	46.55	100	320	Average
5350	51.47	52.32	74.00	-22.53	34.30	11.39	46.54	100	320	Peak
5350	46.97	47.82	54.00	-7.03	34.30	11.39	46.54	100	320	Average

ANTENNA POLARITY & TEST DISTANCE: VERTICAL AT 3 M										
FREQ. (MHz)	EMISSION LEVEL (dBuV/m)	READ LEVEL (dBuV)	LIMIT (dBuV/m)	MARGIN (dB)	ANTENNA FACTOR (dB /m)	CABLE LOSS (dB)	PREAMP FACTOR (dB)	ANTENNA HEIGHT (cm)	TABLE ANGLE (Degree)	REMARK
5150	53.47	54.89	74.00	-20.53	34.00	11.17	46.59	100	55	Peak
5150	46.13	47.55	54.00	-7.87	34.00	11.17	46.59	100	55	Average
5310	91.07	91.63	/	/	34.64	11.35	46.55	100	55	Peak
5310	85.33	85.89	/	/	34.64	11.35	46.55	100	55	Average
5350	50.77	51.12	74.00	-23.23	34.80	11.39	46.54	100	55	Peak
5350	47.13	47.48	54.00	-6.87	34.80	11.39	46.54	100	55	Average

REMARKS:

1. Emission Level = Read Level+ Antenna Factor + Cable Loss- Preamp Factor
Margin value = Emission level – Limit value.
2. 5310MHz: Fundamental frequency.



802.11ac (80MHz)

CHANNEL	TX Channel 58	DETECTOR FUNCTION	Peak (PK)
FREQUENCY RANGE	1GHz ~ 40GHz		Average (AV)

ANTENNA POLARITY & TEST DISTANCE: HORIZONTAL AT 3 M										
FREQ. (MHz)	EMISSION LEVEL (dBuV/m)	READ LEVEL (dBuV)	LIMIT (dBuV/m)	MARGIN (dB)	ANTENNA FACTOR (dB /m)	CABLE LOSS (dB)	PREAMP FACTOR (dB)	ANTENNA HEIGHT (cm)	TABLE ANGLE (Degree)	REMARK
5150	52.05	53.27	74	-21.95	34.2	11.17	46.59	100	200	Peak
5150	46.31	47.53	54	-7.69	34.2	11.17	46.59	100	200	Average
5290	92.26	93.16	/	/	34.34	11.32	46.56	100	200	Peak
5290	86.05	86.95	/	/	34.34	11.32	46.56	100	200	Average
5350	53.17	54.02	74	-20.83	34.3	11.39	46.54	100	200	Peak
5350	47.69	48.54	54	-6.31	34.3	11.39	46.54	100	200	Average

ANTENNA POLARITY & TEST DISTANCE: VERTICAL AT 3 M										
FREQ. (MHz)	EMISSION LEVEL (dBuV/m)	READ LEVEL (dBuV)	LIMIT (dBuV/m)	MARGIN (dB)	ANTENNA FACTOR (dB /m)	CABLE LOSS (dB)	PREAMP FACTOR (dB)	ANTENNA HEIGHT (cm)	TABLE ANGLE (Degree)	REMARK
5150	51.86	53.28	74	-22.14	34	11.17	46.59	100	220	Peak
5150	45.1	46.52	54	-8.9	34	11.17	46.59	100	220	Average
5290	86.38	87.14	/	/	34.48	11.32	46.56	100	220	Peak
5290	79.71	80.47	/	/	34.48	11.32	46.56	100	220	Average
5350	53.81	54.16	74	-20.19	34.8	11.39	46.54	100	220	Peak
5350	47.61	47.96	54	-6.39	34.8	11.39	46.54	100	220	Average

REMARKS:

- Emission Level = Read Level+ Antenna Factor + Cable Loss- Preamp Factor
Margin value = Emission level – Limit value.
- 5290MHz: Fundamental frequency.



BUREAU VERITAS

Test Report No.: W7L-240618W002RF03

802.11ac (80MHz)

Worst case harmonic:

CHANNEL	TX Channel 58	DETECTOR FUNCTION	Peak (PK)
FREQUENCY RANGE	1GHz ~ 40GHz		Average (AV)

ANTENNA POLARITY & TEST DISTANCE: HORIZONTAL AT 3 M

	Freq	Level	Read Level	Limit Line	Over Limit	Factor	Remark	Pol/Phase
	MHz	dBuV/m	dBuV	dBuV/m	dB	dB/m		
1	10588.000	52.26	45.00	74.00	-21.74	7.26	Peak	Horizontal
2	10588.000	43.41	36.15	54.00	-10.59	7.26	Average	Horizontal
3	PK15870.000	60.64	41.35	74.00	-13.36	19.29	Peak	Horizontal
4	PP15870.000	49.78	30.49	54.00	-4.22	19.29	Average	Horizontal

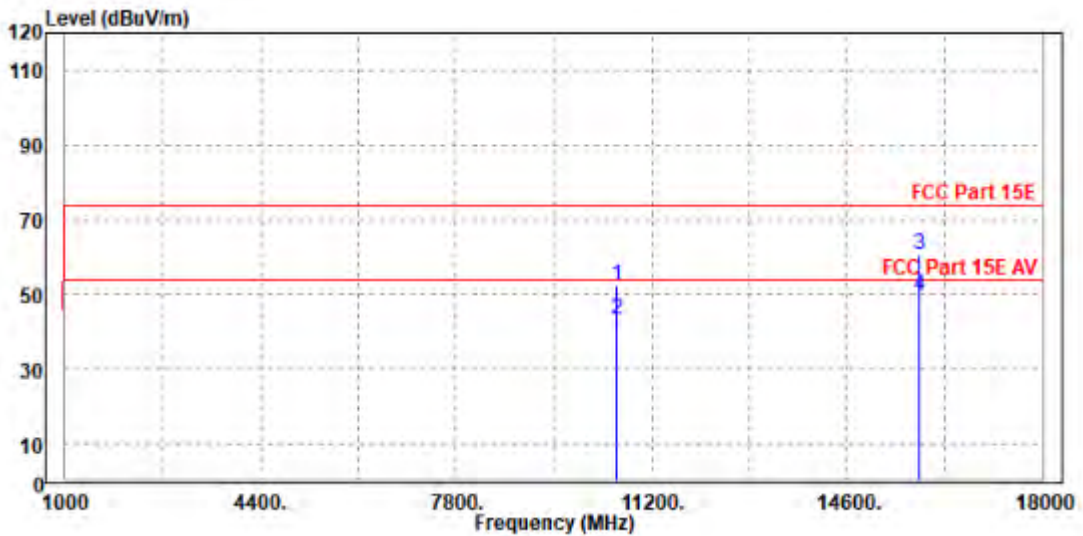



ANTENNA POLARITY & TEST DISTANCE: VERTICAL AT 3 M

	Freq	Level	Read Level	Limit Line	Over Limit	Factor	Remark	Pol/Phase
	MHz	dBuV/m	dBuV	dBuV/m	dB	dB/m		
1	10580.000	52.75	45.54	74.00	-21.25	7.21	Peak	Vertical
2	10580.000	43.86	36.65	54.00	-10.14	7.21	Average	Vertical
3	PK15875.000	59.66	40.40	74.00	-14.34	19.26	Peak	Vertical
4	PP15875.000	49.33	30.07	54.00	-4.67	19.26	Average	Vertical

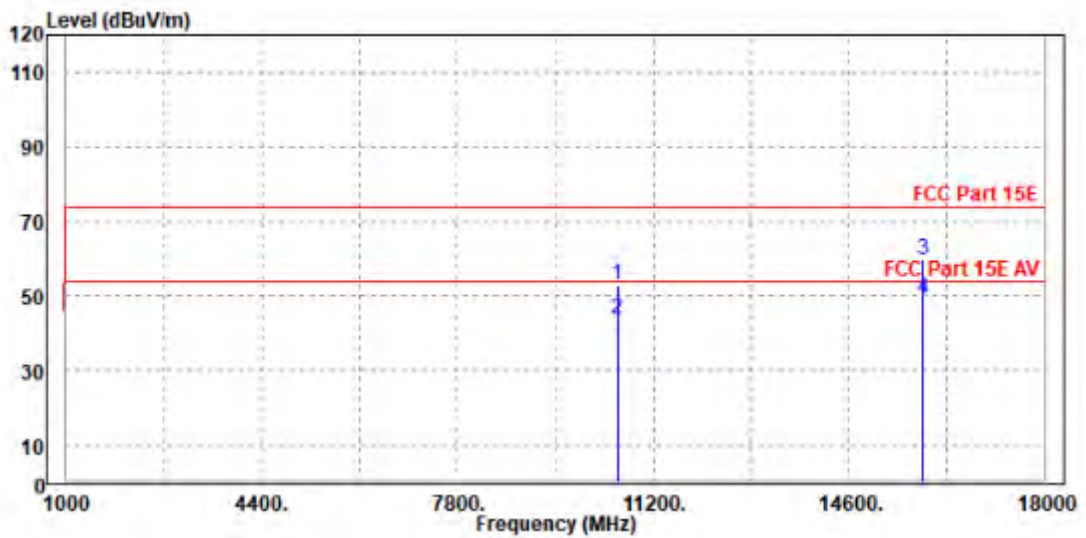

REMARKS:

1. Emission Level = Read Level+ Antenna Factor + Cable Loss- Preamp Factor
Margin value = Emission level – Limit value.
2. 5290MHz: Fundamental frequency.
3. For frequency above 18GHz, the emission was tested 20db below the limit so the data not recorded in the sheet.



Band 3

802.11a

CHANNEL	TX Channel 100	DETECTOR FUNCTION	Peak (PK)
FREQUENCY RANGE	1GHz ~ 40GHz		Average (AV)

ANTENNA POLARITY & TEST DISTANCE: HORIZONTAL AT 3 M										
FREQ. (MHz)	EMISSION LEVEL (dBuV/m)	READ LEVEL (dBuV)	LIMIT (dBuV/m)	MARGIN (dB)	ANTENNA FACTOR (dB /m)	CABLE LOSS (dB)	PREAMP FACTOR (dB)	ANTENNA HEIGHT (cm)	TABLE ANGLE (Degree)	REMARK
5460	52.09	52.5	74	-21.91	34.58	11.52	46.51	100	315	Peak
5460	46.13	46.54	54	-7.87	34.58	11.52	46.51	100	315	Average
5470	51.74	52.16	68.2	-16.46	34.56	11.53	46.51	100	315	Peak
5500	97.96	98.41	/	/	34.5	11.56	46.51	100	315	Peak
5500	93.11	93.56	/	/	34.5	11.56	46.51	100	315	Average

ANTENNA POLARITY & TEST DISTANCE: VERTICAL AT 3 M										
FREQ. (MHz)	EMISSION LEVEL (dBuV/m)	READ LEVEL (dBuV)	LIMIT (dBuV/m)	MARGIN (dB)	ANTENNA FACTOR (dB /m)	CABLE LOSS (dB)	PREAMP FACTOR (dB)	ANTENNA HEIGHT (cm)	TABLE ANGLE (Degree)	REMARK
5460	52.05	52.76	74	-21.95	34.28	11.52	46.51	100	75	Peak
5460	45.57	46.28	54	-8.43	34.28	11.52	46.51	100	75	Average
5470	53.39	54.11	68.2	-14.81	34.26	11.53	46.51	100	75	Peak
5500	93.83	94.58	/	/	34.2	11.56	46.51	100	75	Peak
5500	88.18	88.93	/	/	34.2	11.56	46.51	100	75	Average

REMARKS:

- Emission Level = Read Level+ Antenna Factor + Cable Loss- Preamp Factor
Margin value = Emission level – Limit value.
- 5500MHz: Fundamental frequency.
- #: Out of restricted band.



CHANNEL	TX Channel 116	DETECTOR FUNCTION	Peak (PK)
FREQUENCY RANGE	1GHz ~ 40GHz		Average (AV)

ANTENNA POLARITY & TEST DISTANCE: HORIZONTAL AT 3 M										
FREQ. (MHz)	EMISSION LEVEL (dBuV/m)	READ LEVEL (dBuV)	LIMIT (dBuV/m)	MARGIN (dB)	ANTENNA FACTOR (dB /m)	CABLE LOSS (dB)	PREAMP FACTOR (dB)	ANTENNA HEIGHT (cm)	TABLE ANGLE (Degree)	REMARK
5460	52.41	52.82	74	-21.59	34.58	11.52	46.51	100	315	Peak
5460	46	46.41	54	-8	34.58	11.52	46.51	100	315	Average
5470	51.56	51.98	68.2	-16.64	34.56	11.53	46.51	100	315	Peak
5580	97.71	98.31	/	/	34.3	11.59	46.49	100	315	Peak
5580	92.97	93.57	/	/	34.3	11.59	46.49	100	315	Average

ANTENNA POLARITY & TEST DISTANCE: VERTICAL AT 3 M										
FREQ. (MHz)	EMISSION LEVEL (dBuV/m)	READ LEVEL (dBuV)	LIMIT (dBuV/m)	MARGIN (dB)	ANTENNA FACTOR (dB /m)	CABLE LOSS (dB)	PREAMP FACTOR (dB)	ANTENNA HEIGHT (cm)	TABLE ANGLE (Degree)	REMARK
5460	51.63	52.34	74	-22.37	34.28	11.52	46.51	100	75	Peak
5460	45.41	46.12	54	-8.59	34.28	11.52	46.51	100	75	Average
5470	51.63	52.35	68.2	-16.57	34.26	11.53	46.51	100	75	Peak
5580	93.28	93.24	/	/	34.94	11.59	46.49	100	75	Peak
5580	88.5	88.46	/	/	34.94	11.59	46.49	100	75	Average

REMARKS:

- Emission Level = Read Level+ Antenna Factor + Cable Loss- Preamp Factor
Margin value = Emission level – Limit value.
- 5580MHz: Fundamental frequency.
- #: Out of restricted band.



CHANNEL	TX Channel 140	DETECTOR FUNCTION	Peak (PK)
FREQUENCY RANGE	1GHz ~ 40GHz		Average (AV)

ANTENNA POLARITY & TEST DISTANCE: HORIZONTAL AT 3 M										
FREQ. (MHz)	EMISSION LEVEL (dBuV/m)	READ LEVEL (dBuV)	LIMIT (dBuV/m)	MARGIN (dB)	ANTENNA FACTOR (dB /m)	CABLE LOSS (dB)	PREAMP FACTOR (dB)	ANTENNA HEIGHT (cm)	TABLE ANGLE (Degree)	REMARK
5700	98.57	98.79	/	/	34.6	11.64	46.46	100	340	Peak
5700	93.98	94.2	/	/	34.6	11.64	46.46	100	340	Average
5725	53.57	53.82	68.2	-14.63	34.55	11.65	46.45	100	340	Peak
ANTENNA POLARITY & TEST DISTANCE: VERTICAL AT 3 M										
FREQ. (MHz)	EMISSION LEVEL (dBuV/m)	READ LEVEL (dBuV)	LIMIT (dBuV/m)	MARGIN (dB)	ANTENNA FACTOR (dB /m)	CABLE LOSS (dB)	PREAMP FACTOR (dB)	ANTENNA HEIGHT (cm)	TABLE ANGLE (Degree)	REMARK
5700	93.27	93.79	/	/	34.3	11.64	46.46	100	105	Peak
5700	88.63	89.15	/	/	34.3	11.64	46.46	100	105	Average
5725	53.08	53.53	68.2	-15.12	34.35	11.65	46.45	100	105	Peak

REMARKS:

- Emission Level = Read Level+ Antenna Factor + Cable Loss- Preamp Factor
Margin value = Emission level – Limit value.
- 5700MHz: Fundamental frequency.
- #: Out of restricted band.



802.11n (20MHz)

CHANNEL	TX Channel 100	DETECTOR FUNCTION	Peak (PK)
FREQUENCY RANGE	1GHz ~ 40GHz		Average (AV)

ANTENNA POLARITY & TEST DISTANCE: HORIZONTAL AT 3 M										
FREQ. (MHz)	EMISSION LEVEL (dBuV/m)	READ LEVEL (dBuV)	LIMIT (dBuV/m)	MARGIN (dB)	ANTENNA FACTOR (dB /m)	CABLE LOSS (dB)	PREAMP FACTOR (dB)	ANTENNA HEIGHT (cm)	TABLE ANGLE (Degree)	REMARK
5460	52.29	52.7	74	-21.71	34.58	11.52	46.51	100	330	Peak
5460	46.17	46.58	54	-7.83	34.58	11.52	46.51	100	330	Average
5470	50.64	51.06	68.2	-17.56	34.56	11.53	46.51	100	330	Peak
5500	98.36	98.81	/	/	34.5	11.56	46.51	100	330	Peak
5500	93.31	93.76	/	/	34.5	11.56	46.51	100	330	Average

ANTENNA POLARITY & TEST DISTANCE: VERTICAL AT 3 M										
FREQ. (MHz)	EMISSION LEVEL (dBuV/m)	READ LEVEL (dBuV)	LIMIT (dBuV/m)	MARGIN (dB)	ANTENNA FACTOR (dB /m)	CABLE LOSS (dB)	PREAMP FACTOR (dB)	ANTENNA HEIGHT (cm)	TABLE ANGLE (Degree)	REMARK
5460	51.04	51.75	74	-22.96	34.28	11.52	46.51	100	75	Peak
5460	45.77	46.48	54	-8.23	34.28	11.52	46.51	100	75	Average
5470	51.76	52.48	68.2	-16.44	34.26	11.53	46.51	100	75	Peak
5500	93.29	94.04	/	/	34.2	11.56	46.51	100	75	Peak
5500	87.2	87.95	/	/	34.2	11.56	46.51	100	75	Average

REMARKS:

- Emission Level = Read Level+ Antenna Factor + Cable Loss- Preamp Factor
Margin value = Emission level – Limit value.
- 5500MHz: Fundamental frequency.
- #: Out of restricted band.



CHANNEL	TX Channel 116	DETECTOR FUNCTION	Peak (PK)
FREQUENCY RANGE	1GHz ~ 40GHz		Average (AV)

ANTENNA POLARITY & TEST DISTANCE: HORIZONTAL AT 3 M

FREQ. (MHz)	EMISSION LEVEL (dBuV/m)	READ LEVEL (dBuV)	LIMIT (dBuV/m)	MARGIN (dB)	ANTENNA FACTOR (dB /m)	CABLE LOSS (dB)	PREAMP FACTOR (dB)	ANTENNA HEIGHT (cm)	TABLE ANGLE (Degree)	REMARK
5460	50.61	51.02	74	-23.39	34.58	11.52	46.51	100	325	Peak
5460	45.92	46.33	54	-8.08	34.58	11.52	46.51	100	325	Average
5470	51	51.42	68.2	-17.2	34.56	11.53	46.51	100	325	Peak
5580	97.9	98.5	/	/	34.3	11.59	46.49	100	325	Peak
5580	92.71	93.31	/	/	34.3	11.59	46.49	100	325	Average

ANTENNA POLARITY & TEST DISTANCE: VERTICAL AT 3 M

FREQ. (MHz)	EMISSION LEVEL (dBuV/m)	READ LEVEL (dBuV)	LIMIT (dBuV/m)	MARGIN (dB)	ANTENNA FACTOR (dB /m)	CABLE LOSS (dB)	PREAMP FACTOR (dB)	ANTENNA HEIGHT (cm)	TABLE ANGLE (Degree)	REMARK
5460	51.91	52.62	74	-22.09	34.28	11.52	46.51	100	65	Peak
5460	45.69	46.4	54	-8.31	34.28	11.52	46.51	100	65	Average
5470	51.18	51.9	68.2	-17.02	34.26	11.53	46.51	100	65	Peak
5580	93.54	93.5	/	/	34.94	11.59	46.49	100	65	Peak
5580	88.33	88.29	/	/	34.94	11.59	46.49	100	65	Average

REMARKS:

- Emission Level = Read Level+ Antenna Factor + Cable Loss- Preamp Factor
Margin value = Emission level – Limit value.
- 5580MHz: Fundamental frequency.
- #: Out of restricted band.



CHANNEL	TX Channel 140	DETECTOR FUNCTION	Peak (PK)
FREQUENCY RANGE	1GHz ~ 40GHz		Average (AV)

ANTENNA POLARITY & TEST DISTANCE: HORIZONTAL AT 3 M										
FREQ. (MHz)	EMISSION LEVEL (dBuV/m)	READ LEVEL (dBuV)	LIMIT (dBuV/m)	MARGIN (dB)	ANTENNA FACTOR (dB /m)	CABLE LOSS (dB)	PREAMP FACTOR (dB)	ANTENNA HEIGHT (cm)	TABLE ANGLE (Degree)	REMARK
5700	98.86	99.08	/	/	34.6	11.64	46.46	100	335	Peak
5700	94.27	94.49	/	/	34.6	11.64	46.46	100	335	Average
5725	53.6	53.85	68.2	-14.6	34.55	11.65	46.45	100	335	Peak
ANTENNA POLARITY & TEST DISTANCE: VERTICAL AT 3 M										
FREQ. (MHz)	EMISSION LEVEL (dBuV/m)	READ LEVEL (dBuV)	LIMIT (dBuV/m)	MARGIN (dB)	ANTENNA FACTOR (dB /m)	CABLE LOSS (dB)	PREAMP FACTOR (dB)	ANTENNA HEIGHT (cm)	TABLE ANGLE (Degree)	REMARK
5700	94.46	94.98	/	/	34.3	11.64	46.46	100	105	Peak
5700	88.82	89.34	/	/	34.3	11.64	46.46	100	105	Average
5725	52.01	52.46	68.2	-16.19	34.35	11.65	46.45	100	105	Peak

REMARKS:

- Emission Level = Read Level+ Antenna Factor + Cable Loss- Preamp Factor
Margin value = Emission level – Limit value.
- 5700MHz: Fundamental frequency.
- #: Out of restricted band.



CHANNEL	TX Channel 144	DETECTOR FUNCTION	Peak (PK)
FREQUENCY RANGE	1GHz ~ 40GHz		Average (AV)

ANTENNA POLARITY & TEST DISTANCE: HORIZONTAL AT 3 M										
FREQ. (MHz)	EMISSION LEVEL (dBuV/m)	READ LEVEL (dBuV)	LIMIT (dBuV/m)	MARGIN (dB)	ANTENNA FACTOR (dB /m)	CABLE LOSS (dB)	PREAMP FACTOR (dB)	ANTENNA HEIGHT (cm)	TABLE ANGLE (Degree)	REMARK
5470	50.95	51.37	68.2	-17.25	34.56	11.53	46.51	100	335	Peak
5720	99.28	99.53	/	/	34.56	11.64	46.45	100	335	Peak
5720	93.82	94.07	/	/	34.56	11.64	46.45	100	335	Average
5850	50.69	50.52	68.2	-17.51	34.9	11.69	46.42	100	335	Peak
ANTENNA POLARITY & TEST DISTANCE: VERTICAL AT 3 M										
FREQ. (MHz)	EMISSION LEVEL (dBuV/m)	READ LEVEL (dBuV)	LIMIT (dBuV/m)	MARGIN (dB)	ANTENNA FACTOR (dB /m)	CABLE LOSS (dB)	PREAMP FACTOR (dB)	ANTENNA HEIGHT (cm)	TABLE ANGLE (Degree)	REMARK
5470	50.95	51.67	68.2	-17.25	34.26	11.53	46.51	100	95	Peak
5720	93.03	93.5	/	/	34.34	11.64	46.45	100	95	Peak
5720	87.94	88.41	/	/	34.34	11.64	46.45	100	95	Average
5850	53.47	52.9	68.2	-14.73	35.3	11.69	46.42	100	95	Peak

REMARKS:

- Emission Level = Read Level+ Antenna Factor + Cable Loss- Preamp Factor
Margin value = Emission level – Limit value.
- 57020MHz: Fundamental frequency.
- #: Out of restricted band.



802.11n (40MHz)

CHANNEL	TX Channel 102	DETECTOR FUNCTION	Peak (PK)
FREQUENCY RANGE	1GHz ~ 40GHz		Average (AV)

ANTENNA POLARITY & TEST DISTANCE: HORIZONTAL AT 3 M

FREQ. (MHz)	EMISSION LEVEL (dBuV/m)	READ LEVEL (dBuV)	LIMIT (dBuV/m)	MARGIN (dB)	ANTENNA FACTOR (dB /m)	CABLE LOSS (dB)	PREAMP FACTOR (dB)	ANTENNA HEIGHT (cm)	TABLE ANGLE (Degree)	REMARK
5460	51.27	51.68	74	-22.73	34.58	11.52	46.51	100	330	Peak
5460	46.72	47.13	54	-7.28	34.58	11.52	46.51	100	330	Average
5470	54.74	55.16	68.2	-13.46	34.56	11.53	46.51	100	330	Peak
5510	95.21	95.69	/	/	34.46	11.56	46.5	100	330	Peak
5510	89.78	90.26	/	/	34.46	11.56	46.5	100	330	Average

ANTENNA POLARITY & TEST DISTANCE: VERTICAL AT 3 M

FREQ. (MHz)	EMISSION LEVEL (dBuV/m)	READ LEVEL (dBuV)	LIMIT (dBuV/m)	MARGIN (dB)	ANTENNA FACTOR (dB /m)	CABLE LOSS (dB)	PREAMP FACTOR (dB)	ANTENNA HEIGHT (cm)	TABLE ANGLE (Degree)	REMARK
5460	49.42	50.13	74	-24.58	34.28	11.52	46.51	100	95	Peak
5460	45.98	46.69	54	-8.02	34.28	11.52	46.51	100	95	Average
5470	51.7	52.42	68.2	-16.5	34.26	11.53	46.51	100	95	Peak
5510	89.85	90.49	/	/	34.3	11.56	46.5	100	95	Peak
5510	83.91	84.55	/	/	34.3	11.56	46.5	100	95	Average

REMARKS:

- Emission Level = Read Level+ Antenna Factor + Cable Loss- Preamp Factor
Margin value = Emission level – Limit value.
- 5510MHz: Fundamental frequency.
- #: Out of restricted band.



CHANNEL	TX Channel 110	DETECTOR FUNCTION	Peak (PK)
FREQUENCY RANGE	1GHz ~ 40GHz		Average (AV)

ANTENNA POLARITY & TEST DISTANCE: HORIZONTAL AT 3 M

FREQ. (MHz)	EMISSION LEVEL (dBuV/m)	READ LEVEL (dBuV)	LIMIT (dBuV/m)	MARGIN (dB)	ANTENNA FACTOR (dB /m)	CABLE LOSS (dB)	PREAMP FACTOR (dB)	ANTENNA HEIGHT (cm)	TABLE ANGLE (Degree)	REMARK
5460	52.87	53.28	74	-21.13	34.58	11.52	46.51	100	320	Peak
5460	46.36	46.77	54	-7.64	34.58	11.52	46.51	100	320	Average
5470	51.96	52.38	68.2	-16.24	34.56	11.53	46.51	100	320	Peak
5550	95.19	95.8	/	/	34.3	11.58	46.49	100	320	Peak
5550	90.29	90.9	/	/	34.3	11.58	46.49	100	320	Average

ANTENNA POLARITY & TEST DISTANCE: VERTICAL AT 3 M

FREQ. (MHz)	EMISSION LEVEL (dBuV/m)	READ LEVEL (dBuV)	LIMIT (dBuV/m)	MARGIN (dB)	ANTENNA FACTOR (dB /m)	CABLE LOSS (dB)	PREAMP FACTOR (dB)	ANTENNA HEIGHT (cm)	TABLE ANGLE (Degree)	REMARK
5460	51.71	52.42	74	-22.29	34.28	11.52	46.51	100	105	Peak
5460	45.85	46.56	54	-8.15	34.28	11.52	46.51	100	105	Average
5470	51.08	51.8	68.2	-17.12	34.26	11.53	46.51	100	105	Peak
5550	89.91	90.12	/	/	34.7	11.58	46.49	100	105	Peak
5550	84.82	85.03	/	/	34.7	11.58	46.49	100	105	Average

REMARKS:

- Emission Level = Read Level+ Antenna Factor + Cable Loss- Preamp Factor
Margin value = Emission level – Limit value.
- 5500MHz: Fundamental frequency.
- #: Out of restricted band.



CHANNEL	TX Channel 134	DETECTOR FUNCTION	Peak (PK)
FREQUENCY RANGE	1GHz ~ 40GHz		Average (AV)

ANTENNA POLARITY & TEST DISTANCE: HORIZONTAL AT 3 M

FREQ. (MHz)	EMISSION LEVEL (dBuV/m)	READ LEVEL (dBuV)	LIMIT (dBuV/m)	MARGIN (dB)	ANTENNA FACTOR (dB /m)	CABLE LOSS (dB)	PREAMP FACTOR (dB)	ANTENNA HEIGHT (cm)	TABLE ANGLE (Degree)	REMARK
5670	95.48	95.72	/	/	34.6	11.62	46.46	100	330	Peak
5670	90.31	90.55	/	/	34.6	11.62	46.46	100	330	Average
5725	51.59	51.84	68.2	-16.61	34.55	11.65	46.45	100	330	Peak

ANTENNA POLARITY & TEST DISTANCE: VERTICAL AT 3 M

FREQ. (MHz)	EMISSION LEVEL (dBuV/m)	READ LEVEL (dBuV)	LIMIT (dBuV/m)	MARGIN (dB)	ANTENNA FACTOR (dB /m)	CABLE LOSS (dB)	PREAMP FACTOR (dB)	ANTENNA HEIGHT (cm)	TABLE ANGLE (Degree)	REMARK
5670	90.52	90.94	/	/	34.42	11.62	46.46	100	105	Peak
5670	85.41	85.83	/	/	34.42	11.62	46.46	100	105	Average
5725	52.92	53.37	68.2	-15.28	34.35	11.65	46.45	100	105	Peak

REMARKS:

- Emission Level = Read Level+ Antenna Factor + Cable Loss- Preamp Factor
Margin value = Emission level – Limit value.
- 5670MHz: Fundamental frequency.
- #: Out of restricted band.



CHANNEL	TX Channel 142	DETECTOR FUNCTION	Peak (PK)
FREQUENCY RANGE	1GHz ~ 40GHz		Average (AV)

ANTENNA POLARITY & TEST DISTANCE: HORIZONTAL AT 3 M										
FREQ. (MHz)	EMISSION LEVEL (dBuV/m)	READ LEVEL (dBuV)	LIMIT (dBuV/m)	MARGIN (dB)	ANTENNA FACTOR (dB /m)	CABLE LOSS (dB)	PREAMP FACTOR (dB)	ANTENNA HEIGHT (cm)	TABLE ANGLE (Degree)	REMARK
5470	50.62	51.04	68.2	-17.58	34.56	11.53	46.51	100	335	Peak
5710	96.23	96.46	/	/	34.58	11.64	46.45	100	335	Peak
5710	91.12	91.35	/	/	34.58	11.64	46.45	100	335	Average
5850	53.46	53.29	68.2	-14.74	34.9	11.69	46.42	100	335	Peak
ANTENNA POLARITY & TEST DISTANCE: VERTICAL AT 3 M										
FREQ. (MHz)	EMISSION LEVEL (dBuV/m)	READ LEVEL (dBuV)	LIMIT (dBuV/m)	MARGIN (dB)	ANTENNA FACTOR (dB /m)	CABLE LOSS (dB)	PREAMP FACTOR (dB)	ANTENNA HEIGHT (cm)	TABLE ANGLE (Degree)	REMARK
5470	50.94	51.66	68.2	-17.26	34.26	11.53	46.51	100	105	Peak
5710	90.17	90.66	/	/	34.32	11.64	46.45	100	105	Peak
5710	85.94	86.43	/	/	34.32	11.64	46.45	100	105	Average
5850	54.46	53.89	68.2	-13.74	35.3	11.69	46.42	100	105	Peak

REMARKS:

1. Emission Level = Read Level+ Antenna Factor + Cable Loss- Preamp Factor
Margin value = Emission level – Limit value.
2. 5710MHz: Fundamental frequency.
3. #: Out of restricted band.



802.11ac (80MHz)

CHANNEL	TX Channel 106	DETECTOR FUNCTION	Peak (PK)
FREQUENCY RANGE	1GHz ~ 40GHz		Average (AV)

ANTENNA POLARITY & TEST DISTANCE: HORIZONTAL AT 3 M										
FREQ. (MHz)	EMISSION LEVEL (dBuV/m)	READ LEVEL (dBuV)	LIMIT (dBuV/m)	MARGIN (dB)	ANTENNA FACTOR (dB /m)	CABLE LOSS (dB)	PREAMP FACTOR (dB)	ANTENNA HEIGHT (cm)	TABLE ANGLE (Degree)	REMARK
5460	52.22	52.63	74	-21.78	34.58	11.52	46.51	100	315	Peak
5460	47.5	47.91	54	-6.5	34.58	11.52	46.51	100	315	Average
5470	52.7	53.12	68.2	-15.5	34.56	11.53	46.51	100	315	Peak
5530	91.02	91.57	/	/	34.38	11.57	46.5	100	315	Peak
5530	87.09	87.64	/	/	34.38	11.57	46.5	100	315	Average
ANTENNA POLARITY & TEST DISTANCE: VERTICAL AT 3 M										
FREQ. (MHz)	EMISSION LEVEL (dBuV/m)	READ LEVEL (dBuV)	LIMIT (dBuV/m)	MARGIN (dB)	ANTENNA FACTOR (dB /m)	CABLE LOSS (dB)	PREAMP FACTOR (dB)	ANTENNA HEIGHT (cm)	TABLE ANGLE (Degree)	REMARK
5460	50.96	51.67	74	-23.04	34.28	11.52	46.51	100	105	Peak
5460	46.34	47.05	54	-7.66	34.28	11.52	46.51	100	105	Average
5470	49.89	50.61	68.2	-18.31	34.26	11.53	46.51	100	105	Peak
5530	86.49	86.92	/	/	34.5	11.57	46.5	100	105	Peak
5530	80.83	81.26	/	/	34.5	11.57	46.5	100	105	Average

REMARKS:

1. Emission Level = Read Level+ Antenna Factor + Cable Loss- Preamp Factor
Margin value = Emission level – Limit value.
2. 5530MHz: Fundamental frequency.
3. #: Out of restricted band.



CHANNEL	TX Channel 122	DETECTOR FUNCTION	Peak (PK)
FREQUENCY RANGE	1GHz ~ 40GHz		Average (AV)

ANTENNA POLARITY & TEST DISTANCE: HORIZONTAL AT 3 M										
FREQ. (MHz)	EMISSION LEVEL (dBuV/m)	READ LEVEL (dBuV)	LIMIT (dBuV/m)	MARGIN (dB)	ANTENNA FACTOR (dB /m)	CABLE LOSS (dB)	PREAMP FACTOR (dB)	ANTENNA HEIGHT (cm)	TABLE ANGLE (Degree)	REMARK
5460	50.11	50.52	74	-23.89	34.58	11.52	46.51	100	335	Peak
5460	46.4	46.81	54	-7.6	34.58	11.52	46.51	100	335	Average
5470	49.78	50.2	68.2	-18.42	34.56	11.53	46.51	100	335	Peak
5610	91.27	91.79	/	/	34.36	11.6	46.48	100	335	Peak
5610	86.53	87.05	/	/	34.36	11.6	46.48	100	335	Average
ANTENNA POLARITY & TEST DISTANCE: VERTICAL AT 3 M										
FREQ. (MHz)	EMISSION LEVEL (dBuV/m)	READ LEVEL (dBuV)	LIMIT (dBuV/m)	MARGIN (dB)	ANTENNA FACTOR (dB /m)	CABLE LOSS (dB)	PREAMP FACTOR (dB)	ANTENNA HEIGHT (cm)	TABLE ANGLE (Degree)	REMARK
5460	51.64	52.35	74	-22.36	34.28	11.52	46.51	100	105	Peak
5460	46.88	47.59	54	-7.12	34.28	11.52	46.51	100	105	Average
5470	51.78	52.5	68.2	-16.42	34.26	11.53	46.51	100	105	Peak
5610	86.64	86.54	/	/	34.98	11.6	46.48	100	105	Peak
5610	82.12	82.02	/	/	34.98	11.6	46.48	100	105	Average

REMARKS:

- Emission Level = Read Level+ Antenna Factor + Cable Loss- Preamp Factor
Margin value = Emission level – Limit value.
- 5610MHz: Fundamental frequency.
- #: Out of restricted band.



CHANNEL	TX Channel 138	DETECTOR FUNCTION	Peak (PK)
FREQUENCY RANGE	1GHz ~ 40GHz		Average (AV)

ANTENNA POLARITY & TEST DISTANCE: HORIZONTAL AT 3 M										
FREQ. (MHz)	EMISSION LEVEL (dBuV/m)	READ LEVEL (dBuV)	LIMIT (dBuV/m)	MARGIN (dB)	ANTENNA FACTOR (dB /m)	CABLE LOSS (dB)	PREAMP FACTOR (dB)	ANTENNA HEIGHT (cm)	TABLE ANGLE (Degree)	REMARK
5470	50.73	51.15	68.2	-17.47	34.56	11.53	46.51	100	335	Peak
5690	91.47	91.7	/	/	34.6	11.63	46.46	100	335	Peak
5690	87.43	87.66	/	/	34.6	11.63	46.46	100	335	Average
5850	52.81	52.64	68.2	-15.39	34.9	11.69	46.42	100	335	Peak
ANTENNA POLARITY & TEST DISTANCE: VERTICAL AT 3 M										
FREQ. (MHz)	EMISSION LEVEL (dBuV/m)	READ LEVEL (dBuV)	LIMIT (dBuV/m)	MARGIN (dB)	ANTENNA FACTOR (dB /m)	CABLE LOSS (dB)	PREAMP FACTOR (dB)	ANTENNA HEIGHT (cm)	TABLE ANGLE (Degree)	REMARK
5470	50.39	51.11	68.2	-17.81	34.26	11.53	46.51	100	105	Peak
5690	86.79	87.28	/	/	34.34	11.63	46.46	100	105	Peak
5690	83.12	83.61	/	/	34.34	11.63	46.46	100	105	Average
5850	53.88	53.31	68.2	-14.32	35.3	11.69	46.42	100	105	Peak

REMARKS:

1. Emission Level = Read Level+ Antenna Factor + Cable Loss- Preamp Factor
Margin value = Emission level – Limit value.
2. 5690MHz: Fundamental frequency.
3. #: Out of restricted band.



802.11ac (80MHz)

Worst case harmonic:

CHANNEL	TX Channel 106	DETECTOR FUNCTION	Peak (PK)
FREQUENCY RANGE	1GHz ~ 40GHz		Average (AV)

ANTENNA POLARITY & TEST DISTANCE: HORIZONTAL AT 3 M

	Freq	Level	Read Level	Limit Line	Over Limit	Factor	Remark	Pol/Phase
	MHz	dBuV/m	dBuV	dBuV/m	dB	dB/m		
1	11060.000	52.37	45.39	74.00	-21.63	6.98	Peak	Horizontal
2	11060.000	44.25	37.27	54.00	-9.75	6.98	Average	Horizontal
3	PK16589.000	58.44	40.43	74.00	-15.56	18.01	Peak	Horizontal
4	PP16589.000	50.77	32.76	54.00	-3.23	18.01	Average	Horizontal

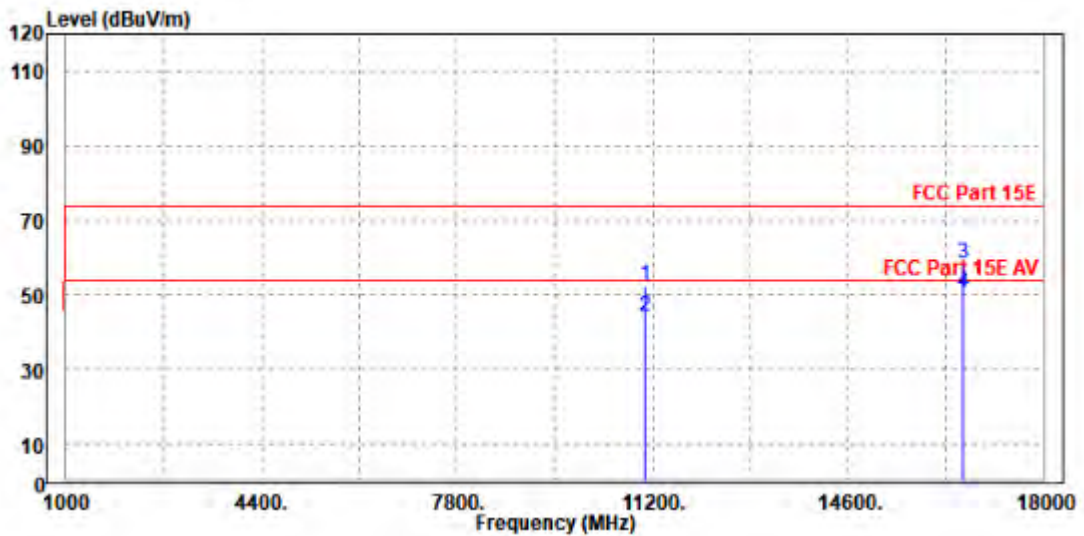



ANTENNA POLARITY & TEST DISTANCE: VERTICAL AT 3 M

	Freq	Level	Read Level	Limit Line	Over Limit	Factor	Remark	Pol/Phase
	MHz	dBuV/m	dBuV	dBuV/m	dB	dB/m		
1	11064.000	52.85	45.34	74.00	-21.15	7.51	Peak	Vertical
2	11064.000	43.75	36.24	54.00	-10.25	7.51	Average	Vertical
3	PK16590.000	58.77	40.96	74.00	-15.23	17.81	Peak	Vertical
4	PP16590.000	50.43	32.62	54.00	-3.57	17.81	Average	Vertical

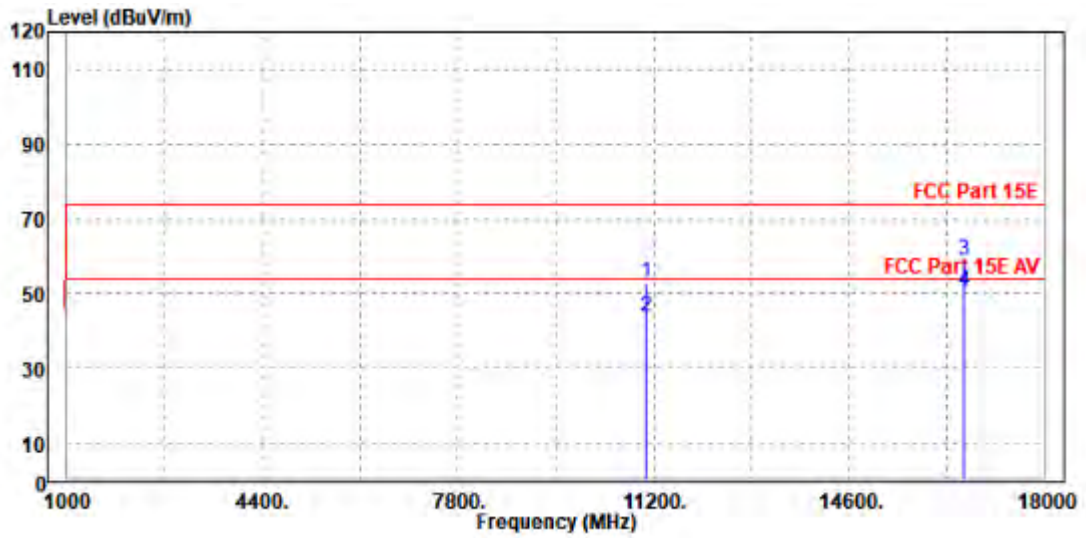

REMARKS:

1. Emission Level = Read Level+ Antenna Factor + Cable Loss- Preamp Factor
Margin value = Emission level – Limit value.
2. 5530MHz: Fundamental frequency.
3. For frequency above 18GHz, the emission was tested 20db below the limit so the data not recorded in the sheet.



Band 4:

802.11a

CHANNEL	TX Channel 149	DETECTOR FUNCTION	Peak (PK)
FREQUENCY RANGE	1GHz ~ 40GHz		Average (AV)

ANTENNA POLARITY & TEST DISTANCE: HORIZONTAL AT 3 M										
FREQ. (MHz)	EMISSION LEVEL (dBuV/m)	READ LEVEL (dBuV)	LIMIT (dBuV/m)	MARGIN (dB)	ANTENNA FACTOR (dB /m)	CABLE LOSS (dB)	PREAMP FACTOR (dB)	ANTENNA HEIGHT (cm)	TABLE ANGLE (Degree)	REMARK
5745	99.91	100.19	/	/	34.51	11.65	46.44	100	330	Peak
5745	92.77	93.05	/	/	34.51	11.65	46.44	100	330	Average
ANTENNA POLARITY & TEST DISTANCE: VERTICAL AT 3 M										
FREQ. (MHz)	EMISSION LEVEL (dBuV/m)	READ LEVEL (dBuV)	LIMIT (dBuV/m)	MARGIN (dB)	ANTENNA FACTOR (dB /m)	CABLE LOSS (dB)	PREAMP FACTOR (dB)	ANTENNA HEIGHT (cm)	TABLE ANGLE (Degree)	REMARK
5745	93.04	93.44	/	/	34.39	11.65	46.44	100	60	Peak
5745	85.78	86.18	/	/	34.39	11.65	46.44	100	60	Average

REMARKS:

- Emission Level = Read Level+ Antenna Factor + Cable Loss- Preamp Factor
Margin value = Emission level – Limit value.
- 5745MHz: Fundamental frequency.



Oobe Data

802.11a

ANTENNA POLARITY & TEST DISTANCE: HORIZONTAL AT 3 M										
FREQ. (MHz)	EMISSION LEVEL (dBuV/m)	READ LEVEL (dBuV)	LIMIT (dBuV/m)	MARGIN (dB)	ANTENNA FACTOR (dB /m)	CABLE LOSS (dB)	PREAMP FACTOR (dB)	ANTENNA HEIGHT (cm)	TABLE ANGLE (Degree)	REMARK
5607.475	57.7	58.24	68.2	-10.5	34.34	11.6	46.48	100	0	Peak
5996.025	58.17	57.7	68.2	-10.03	35.1	11.75	46.38	100	0	Peak
ANTENNA POLARITY & TEST DISTANCE: VERTICAL AT 3 M										
FREQ. (MHz)	EMISSION LEVEL (dBuV/m)	READ LEVEL (dBuV)	LIMIT (dBuV/m)	MARGIN (dB)	ANTENNA FACTOR (dB /m)	CABLE LOSS (dB)	PREAMP FACTOR (dB)	ANTENNA HEIGHT (cm)	TABLE ANGLE (Degree)	REMARK
5569	58.29	58.34	68.2	-9.91	34.85	11.59	46.49	100	360	Peak
6001.25	58.54	58.16	68.2	-9.66	35.01	11.75	46.38	100	360	Peak

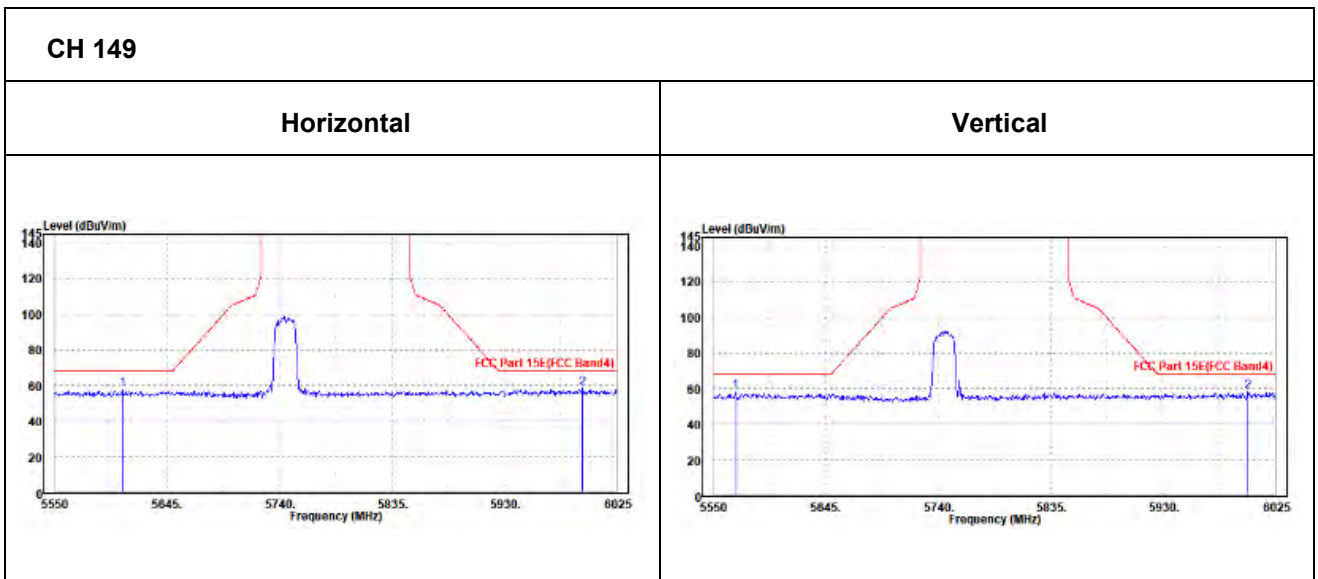



CHANNEL	TX Channel 157	DETECTOR FUNCTION	Peak (PK)
FREQUENCY RANGE	1GHz ~ 40GHz		Average (AV)

ANTENNA POLARITY & TEST DISTANCE: HORIZONTAL AT 3 M

FREQ. (MHz)	EMISSION LEVEL (dBuV/m)	READ LEVEL (dBuV)	LIMIT (dBuV/m)	MARGIN (dB)	ANTENNA FACTOR (dB /m)	CABLE LOSS (dB)	PREAMP FACTOR (dB)	ANTENNA HEIGHT (cm)	TABLE ANGLE (Degree)	REMARK
5785	99.89	100.01	/	/	34.64	11.67	46.43	100	330	Peak
5785	93.71	93.83	/	/	34.64	11.67	46.43	100	330	Average

ANTENNA POLARITY & TEST DISTANCE: VERTICAL AT 3 M

FREQ. (MHz)	EMISSION LEVEL (dBuV/m)	READ LEVEL (dBuV)	LIMIT (dBuV/m)	MARGIN (dB)	ANTENNA FACTOR (dB /m)	CABLE LOSS (dB)	PREAMP FACTOR (dB)	ANTENNA HEIGHT (cm)	TABLE ANGLE (Degree)	REMARK
5785	93.52	93.53	/	/	34.75	11.67	46.43	100	60	Peak
5785	86.69	86.7	/	/	34.75	11.67	46.43	100	60	Average

REMARKS:

- Emission Level = Read Level+ Antenna Factor + Cable Loss- Preamp Factor
Margin value = Emission level – Limit value.
- 5785MHz: Fundamental frequency.



Oobe Data

802.11a

ANTENNA POLARITY & TEST DISTANCE: HORIZONTAL AT 3 M										
FREQ. (MHz)	EMISSION LEVEL (dBuV/m)	READ LEVEL (dBuV)	LIMIT (dBuV/m)	MARGIN (dB)	ANTENNA FACTOR (dB /m)	CABLE LOSS (dB)	PREAMP FACTOR (dB)	ANTENNA HEIGHT (cm)	TABLE ANGLE (Degree)	REMARK
5614.125	57.14	57.64	68.2	-11.06	34.38	11.6	46.48	100	360	Peak
5984.15	58.82	58.36	68.2	-9.38	35.1	11.74	46.38	100	360	Peak
ANTENNA POLARITY & TEST DISTANCE: VERTICAL AT 3 M										
FREQ. (MHz)	EMISSION LEVEL (dBuV/m)	READ LEVEL (dBuV)	LIMIT (dBuV/m)	MARGIN (dB)	ANTENNA FACTOR (dB /m)	CABLE LOSS (dB)	PREAMP FACTOR (dB)	ANTENNA HEIGHT (cm)	TABLE ANGLE (Degree)	REMARK
5607.475	57.36	57.23	68.2	-10.84	35.01	11.6	46.48	100	0	Peak
6000.3	58.26	57.89	68.2	-9.94	35	11.75	46.38	100	0	Peak

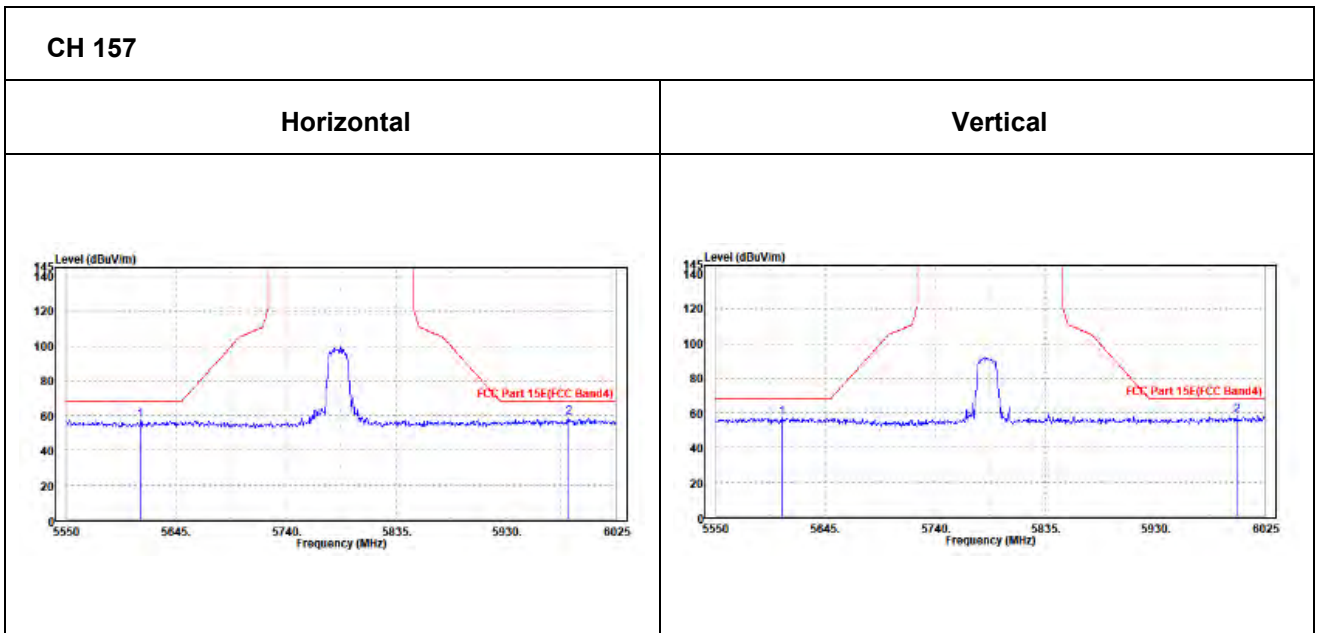



CHANNEL	TX Channel 165	DETECTOR FUNCTION	Peak (PK)
FREQUENCY RANGE	1GHz ~ 40GHz		Average (AV)

ANTENNA POLARITY & TEST DISTANCE: HORIZONTAL AT 3 M

FREQ. (MHz)	EMISSION LEVEL (dBuV/m)	READ LEVEL (dBuV)	LIMIT (dBuV/m)	MARGIN (dB)	ANTENNA FACTOR (dB /m)	CABLE LOSS (dB)	PREAMP FACTOR (dB)	ANTENNA HEIGHT (cm)	TABLE ANGLE (Degree)	REMARK
5825	100.01	99.95	/	/	34.8	11.68	46.42	100	330	Peak
5825	94.52	94.46	/	/	34.8	11.68	46.42	100	330	Average

ANTENNA POLARITY & TEST DISTANCE: VERTICAL AT 3 M

FREQ. (MHz)	EMISSION LEVEL (dBuV/m)	READ LEVEL (dBuV)	LIMIT (dBuV/m)	MARGIN (dB)	ANTENNA FACTOR (dB /m)	CABLE LOSS (dB)	PREAMP FACTOR (dB)	ANTENNA HEIGHT (cm)	TABLE ANGLE (Degree)	REMARK
5825	93.51	93.15	/	/	35.1	11.68	46.42	100	60	Peak
5825	86.92	86.56	/	/	35.1	11.68	46.42	100	60	Average

REMARKS:

- Emission Level = Read Level+ Antenna Factor + Cable Loss- Preamp Factor
Margin value = Emission level – Limit value.
- 5825MHz: Fundamental frequency.



Oobe Data

802.11a

ANTENNA POLARITY & TEST DISTANCE: HORIZONTAL AT 3 M										
FREQ. (MHz)	EMISSION LEVEL (dBuV/m)	READ LEVEL (dBuV)	LIMIT (dBuV/m)	MARGIN (dB)	ANTENNA FACTOR (dB /m)	CABLE LOSS (dB)	PREAMP FACTOR (dB)	ANTENNA HEIGHT (cm)	TABLE ANGLE (Degree)	REMARK
5594.65	57.71	58.29	68.2	-10.49	34.3	11.6	46.48	100	360	Peak
5978.45	59.92	59.47	68.2	-8.28	35.1	11.74	46.39	100	360	Peak
ANTENNA POLARITY & TEST DISTANCE: VERTICAL AT 3 M										
FREQ. (MHz)	EMISSION LEVEL (dBuV/m)	READ LEVEL (dBuV)	LIMIT (dBuV/m)	MARGIN (dB)	ANTENNA FACTOR (dB /m)	CABLE LOSS (dB)	PREAMP FACTOR (dB)	ANTENNA HEIGHT (cm)	TABLE ANGLE (Degree)	REMARK
5582.3	57.86	57.79	68.2	-10.34	34.96	11.59	46.48	100	0	Peak
6004.575	59.99	59.57	68.2	-8.21	35.04	11.76	46.38	100	0	Peak

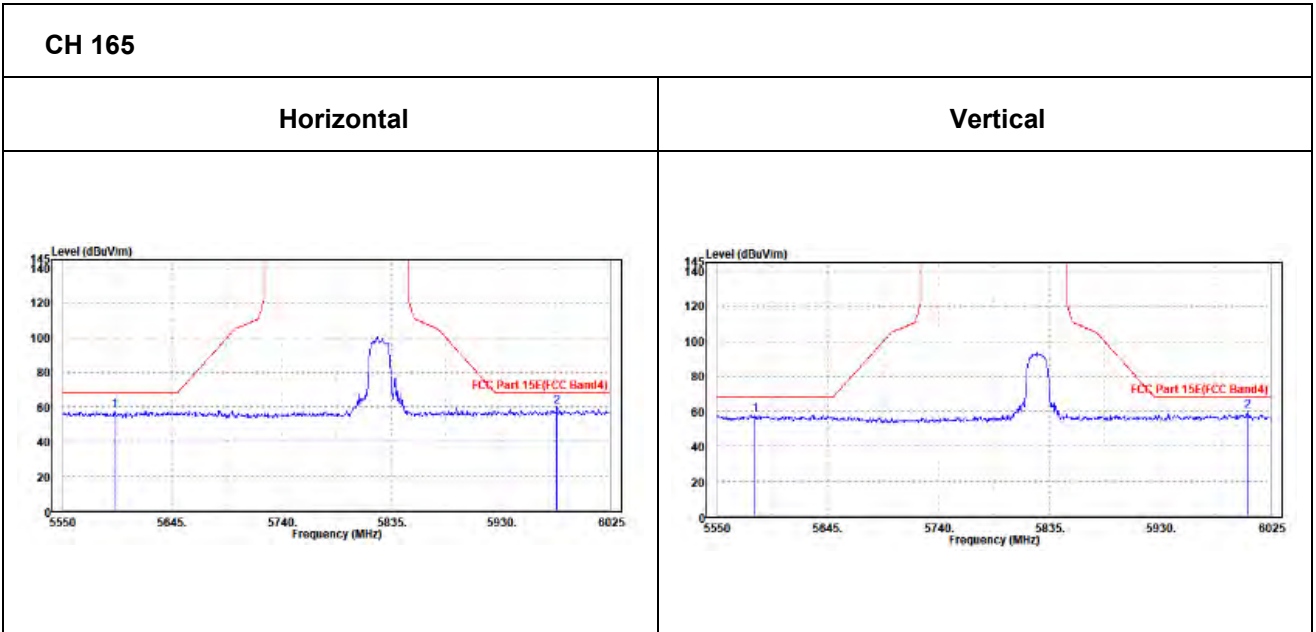



802.11n (20MHz)

CHANNEL	TX Channel 149	DETECTOR FUNCTION	Peak (PK)
FREQUENCY RANGE	1GHz ~ 40GHz		Average (AV)

ANTENNA POLARITY & TEST DISTANCE: HORIZONTAL AT 3 M

FREQ. (MHz)	EMISSION LEVEL (dBuV/m)	READ LEVEL (dBuV)	LIMIT (dBuV/m)	MARGIN (dB)	ANTENNA FACTOR (dB /m)	CABLE LOSS (dB)	PREAMP FACTOR (dB)	ANTENNA HEIGHT (cm)	TABLE ANGLE (Degree)	REMARK
5745	99.35	99.63	/	/	34.51	11.65	46.44	100	330	Peak
5745	92.57	92.85	/	/	34.51	11.65	46.44	100	330	Average

ANTENNA POLARITY & TEST DISTANCE: VERTICAL AT 3 M

FREQ. (MHz)	EMISSION LEVEL (dBuV/m)	READ LEVEL (dBuV)	LIMIT (dBuV/m)	MARGIN (dB)	ANTENNA FACTOR (dB /m)	CABLE LOSS (dB)	PREAMP FACTOR (dB)	ANTENNA HEIGHT (cm)	TABLE ANGLE (Degree)	REMARK
5745	92.28	92.68	/	/	34.39	11.65	46.44	100	60	Peak
5745	85.89	86.29	/	/	34.39	11.65	46.44	100	60	Average

REMARKS:

- Emission Level = Read Level+ Antenna Factor + Cable Loss- Preamp Factor
Margin value = Emission level – Limit value.
- 5745MHz: Fundamental frequency.



Oobe Data

802.11n (20MHz)

ANTENNA POLARITY & TEST DISTANCE: HORIZONTAL AT 3 M										
FREQ. (MHz)	EMISSION LEVEL (dBuV/m)	READ LEVEL (dBuV)	LIMIT (dBuV/m)	MARGIN (dB)	ANTENNA FACTOR (dB /m)	CABLE LOSS (dB)	PREAMP FACTOR (dB)	ANTENNA HEIGHT (cm)	TABLE ANGLE (Degree)	REMARK
5634.55	58.18	58.53	68.2	-10.02	34.51	11.61	46.47	100	0	Peak
6017.4	57.7	57.17	68.2	-10.5	35.13	11.78	46.38	100	0	Peak
ANTENNA POLARITY & TEST DISTANCE: VERTICAL AT 3 M										
FREQ. (MHz)	EMISSION LEVEL (dBuV/m)	READ LEVEL (dBuV)	LIMIT (dBuV/m)	MARGIN (dB)	ANTENNA FACTOR (dB /m)	CABLE LOSS (dB)	PREAMP FACTOR (dB)	ANTENNA HEIGHT (cm)	TABLE ANGLE (Degree)	REMARK
5570.425	58.82	58.86	68.2	-9.38	34.86	11.59	46.49	100	360	Peak
5983.675	58.34	58.01	68.2	-9.86	34.97	11.74	46.38	100	360	Peak

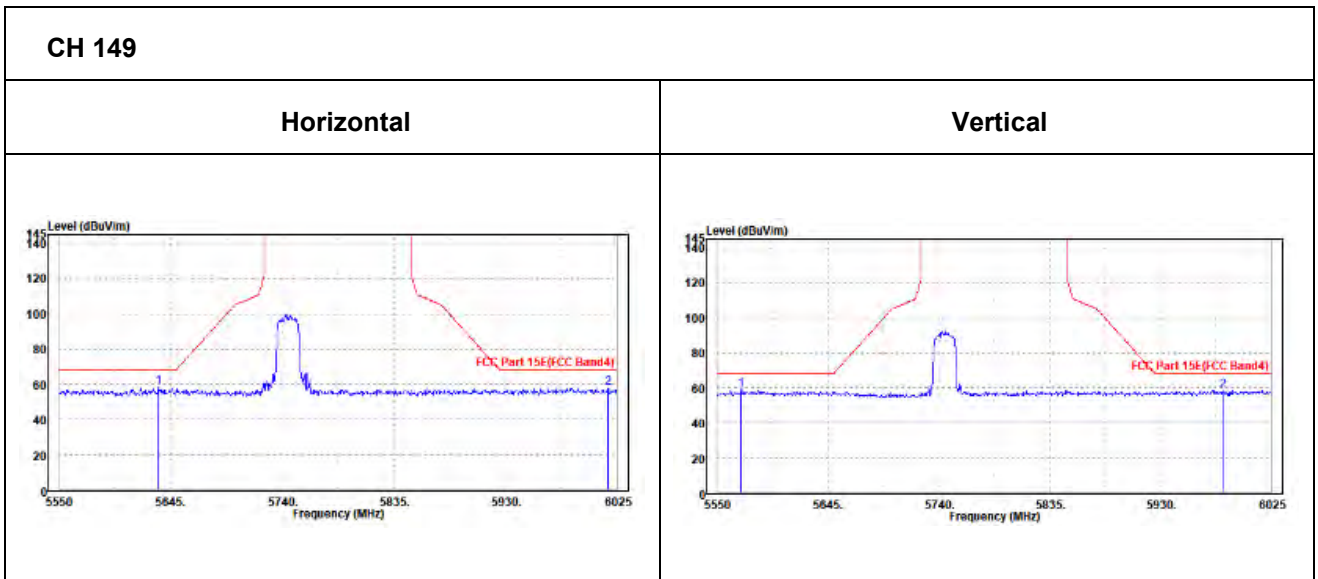



CHANNEL	TX Channel 157	DETECTOR FUNCTION	Peak (PK)
FREQUENCY RANGE	1GHz ~ 40GHz		Average (AV)

ANTENNA POLARITY & TEST DISTANCE: HORIZONTAL AT 3 M

FREQ. (MHz)	EMISSION LEVEL (dBuV/m)	READ LEVEL (dBuV)	LIMIT (dBuV/m)	MARGIN (dB)	ANTENNA FACTOR (dB /m)	CABLE LOSS (dB)	PREAMP FACTOR (dB)	ANTENNA HEIGHT (cm)	TABLE ANGLE (Degree)	REMARK
5785	100.05	100.17	/	/	34.64	11.67	46.43	100	330	Peak
5785	93.61	93.73	/	/	34.64	11.67	46.43	100	330	Average

ANTENNA POLARITY & TEST DISTANCE: VERTICAL AT 3 M

FREQ. (MHz)	EMISSION LEVEL (dBuV/m)	READ LEVEL (dBuV)	LIMIT (dBuV/m)	MARGIN (dB)	ANTENNA FACTOR (dB /m)	CABLE LOSS (dB)	PREAMP FACTOR (dB)	ANTENNA HEIGHT (cm)	TABLE ANGLE (Degree)	REMARK
5785	93.21	93.22	/	/	34.75	11.67	46.43	100	60	Peak
5785	86.39	86.4	/	/	34.75	11.67	46.43	100	60	Average

REMARKS:

- Emission Level = Read Level+ Antenna Factor + Cable Loss- Preamp Factor
Margin value = Emission level – Limit value.
- 5785MHz: Fundamental frequency.



Oobe DATA

802.11n (20MHZ)

ANTENNA POLARITY & TEST DISTANCE: HORIZONTAL AT 3 M										
FREQ. (MHz)	EMISSION LEVEL (dBuV/m)	READ LEVEL (dBuV)	LIMIT (dBuV /m)	MARGIN (dB)	ANTENNA FACTOR (dB /m)	CABLE LOSS (dB)	PREAMP FACTOR (dB)	ANTENNA HEIGHT (cm)	TABLE ANGLE (Degree)	REMARK
5576.6	58.21	58.81	68.2	-9.99	34.3	11.59	46.49	100	360	Peak
5973.7	58.26	57.81	68.2	-9.94	35.1	11.74	46.39	100	360	Peak
ANTENNA POLARITY & TEST DISTANCE: VERTICAL AT 3 M										
FREQ. (MHz)	EMISSION LEVEL (dBuV/m)	READ LEVEL (dBuV)	LIMIT (dBuV /m)	MARGIN (dB)	ANTENNA FACTOR (dB /m)	CABLE LOSS (dB)	PREAMP FACTOR (dB)	ANTENNA HEIGHT (cm)	TABLE ANGLE (Degree)	REMARK
5570.425	59.78	59.82	68.2	-8.42	34.86	11.59	46.49	100	0	Peak
5963.725	58.63	58.35	68.2	-9.57	34.93	11.74	46.39	100	0	Peak

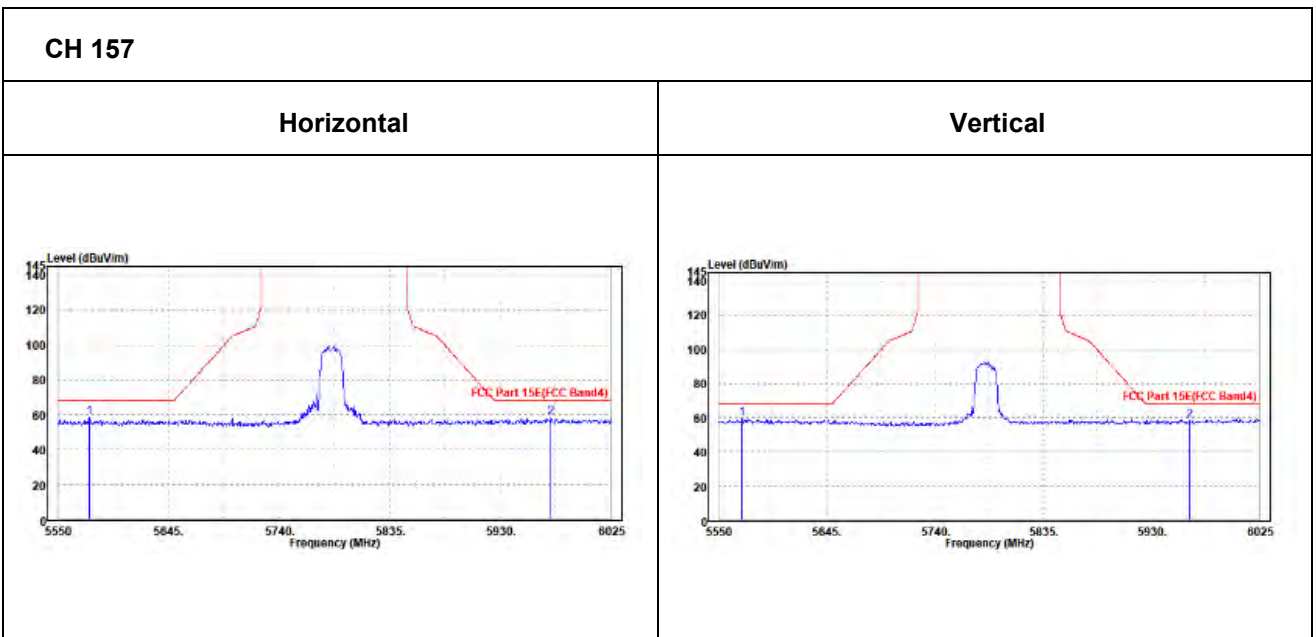



CHANNEL	TX Channel 165	DETECTOR FUNCTION	Peak (PK)
FREQUENCY RANGE	1GHz ~ 40GHz		Average (AV)

ANTENNA POLARITY & TEST DISTANCE: HORIZONTAL AT 3 M										
FREQ. (MHz)	EMISSION LEVEL (dBuV/m)	READ LEVEL (dBuV)	LIMIT (dBuV/m)	MARGIN (dB)	ANTENNA FACTOR (dB /m)	CABLE LOSS (dB)	PREAMP FACTOR (dB)	ANTENNA HEIGHT (cm)	TABLE ANGLE (Degree)	REMARK
5825	99.51	99.45	/	/	34.8	11.68	46.42	100	330	Peak
5825	92.84	92.78	/	/	34.8	11.68	46.42	100	330	Average
ANTENNA POLARITY & TEST DISTANCE: VERTICAL AT 3 M										
FREQ. (MHz)	EMISSION LEVEL (dBuV/m)	READ LEVEL (dBuV)	LIMIT (dBuV/m)	MARGIN (dB)	ANTENNA FACTOR (dB /m)	CABLE LOSS (dB)	PREAMP FACTOR (dB)	ANTENNA HEIGHT (cm)	TABLE ANGLE (Degree)	REMARK
5825	93.31	92.95	/	/	35.1	11.68	46.42	100	60	Peak
5825	86.71	86.35	/	/	35.1	11.68	46.42	100	60	Average

REMARKS:

- Emission Level = Read Level+ Antenna Factor + Cable Loss- Preamp Factor
Margin value = Emission level – Limit value.
- 5825MHz: Fundamental frequency.



OBE DATA

802.11n (20MHz)

ANTENNA POLARITY & TEST DISTANCE: HORIZONTAL AT 3 M										
FREQ. (MHz)	EMISSION LEVEL (dBuV/m)	READ LEVEL (dBuV)	LIMIT (dBuV/m)	MARGIN (dB)	ANTENNA FACTOR (dB /m)	CABLE LOSS (dB)	PREAMP FACTOR (dB)	ANTENNA HEIGHT (cm)	TABLE ANGLE (Degree)	REMARK
5566.625	57.18	57.78	68.2	-11.02	34.3	11.59	46.49	100	0	Peak
5964.675	57.84	57.39	68.2	-10.36	35.1	11.74	46.39	100	0	Peak
ANTENNA POLARITY & TEST DISTANCE: VERTICAL AT 3 M										
FREQ. (MHz)	EMISSION LEVEL (dBuV/m)	READ LEVEL (dBuV)	LIMIT (dBuV/m)	MARGIN (dB)	ANTENNA FACTOR (dB /m)	CABLE LOSS (dB)	PREAMP FACTOR (dB)	ANTENNA HEIGHT (cm)	TABLE ANGLE (Degree)	REMARK
5558.55	58.44	58.58	68.2	-9.76	34.77	11.58	46.49	100	360	Peak
5978.45	59.28	58.97	68.2	-8.92	34.96	11.74	46.39	100	360	Peak

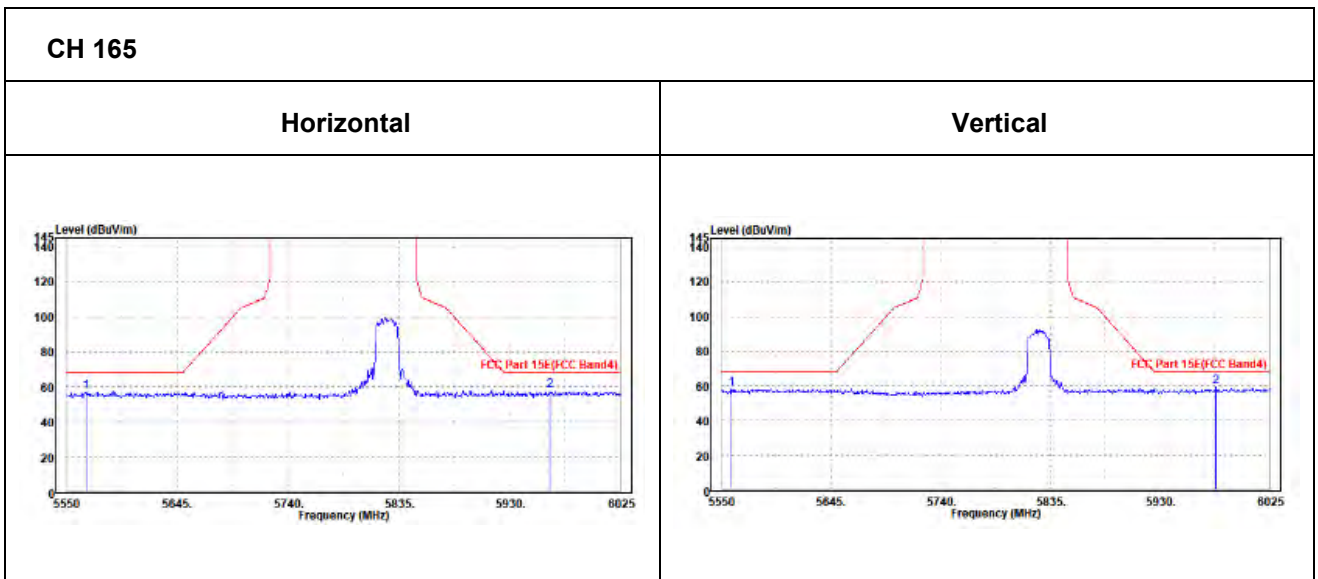



802.11n (40MHz)

CHANNEL	TX Channel 151	DETECTOR FUNCTION	Peak (PK)
FREQUENCY RANGE	1GHz ~ 40GHz		Average (AV)

ANTENNA POLARITY & TEST DISTANCE: HORIZONTAL AT 3 M

FREQ. (MHz)	EMISSION LEVEL (dBuV/m)	READ LEVEL (dBuV)	LIMIT (dBuV/m)	MARGIN (dB)	ANTENNA FACTOR (dB /m)	CABLE LOSS (dB)	PREAMP FACTOR (dB)	ANTENNA HEIGHT (cm)	TABLE ANGLE (Degree)	REMARK
5775	96.77	96.95	/	/	34.6	11.66	46.44	100	330	Peak
5775	89.46	89.64	/	/	34.6	11.66	46.44	100	330	Average

ANTENNA POLARITY & TEST DISTANCE: VERTICAL AT 3 M

FREQ. (MHz)	EMISSION LEVEL (dBuV/m)	READ LEVEL (dBuV)	LIMIT (dBuV/m)	MARGIN (dB)	ANTENNA FACTOR (dB /m)	CABLE LOSS (dB)	PREAMP FACTOR (dB)	ANTENNA HEIGHT (cm)	TABLE ANGLE (Degree)	REMARK
5775	90.57	90.7	/	/	34.65	11.66	46.44	100	60	Peak
5775	84.14	84.27	/	/	34.65	11.66	46.44	100	60	Average

REMARKS:

- Emission Level = Read Level+ Antenna Factor + Cable Loss- Preamp Factor
Margin value = Emission level – Limit value.
- 5755MHz: Fundamental frequency.



Oobe Data

802.11n (40MHz)

ANTENNA POLARITY & TEST DISTANCE: HORIZONTAL AT 3 M										
FREQ. (MHz)	EMISSION LEVEL (dBuV/m)	READ LEVEL (dBuV)	LIMIT (dBuV/m)	MARGIN (dB)	ANTENNA FACTOR (dB /m)	CABLE LOSS (dB)	PREAMP FACTOR (dB)	ANTENNA HEIGHT (cm)	TABLE ANGLE (Degree)	REMARK
5579.925	58.09	58.69	68.2	-10.11	34.3	11.59	46.49	100	0	Peak
5978.45	58.85	58.4	68.2	-9.35	35.1	11.74	46.39	100	0	Peak
ANTENNA POLARITY & TEST DISTANCE: VERTICAL AT 3 M										
FREQ. (MHz)	EMISSION LEVEL (dBuV/m)	READ LEVEL (dBuV)	LIMIT (dBuV/m)	MARGIN (dB)	ANTENNA FACTOR (dB /m)	CABLE LOSS (dB)	PREAMP FACTOR (dB)	ANTENNA HEIGHT (cm)	TABLE ANGLE (Degree)	REMARK
5575.65	58.62	58.61	68.2	-9.58	34.91	11.59	46.49	100	360	Peak
5949.95	59.23	58.99	68.2	-8.97	34.9	11.73	46.39	100	360	Peak

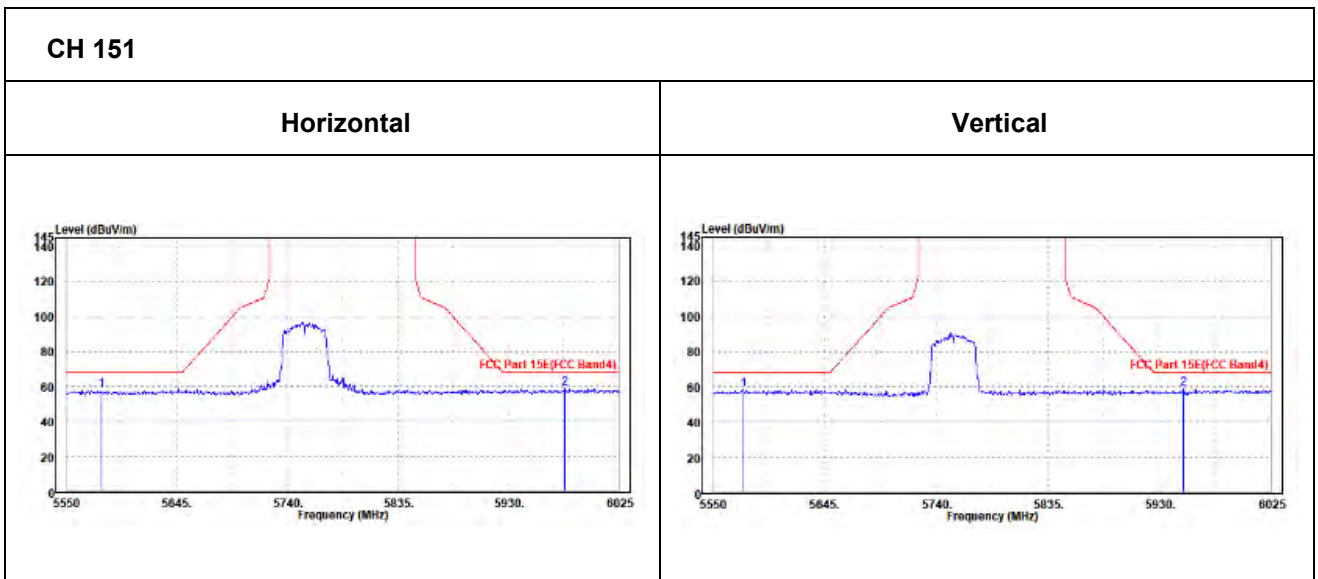



CHANNEL	TX Channel 159	DETECTOR FUNCTION	Peak (PK)
FREQUENCY RANGE	1GHz ~ 40GHz		Average (AV)

ANTENNA POLARITY & TEST DISTANCE: HORIZONTAL AT 3 M

FREQ. (MHz)	EMISSION LEVEL (dBuV/m)	READ LEVEL (dBuV)	LIMIT (dBuV/m)	MARGIN (dB)	ANTENNA FACTOR (dB /m)	CABLE LOSS (dB)	PREAMP FACTOR (dB)	ANTENNA HEIGHT (cm)	TABLE ANGLE (Degree)	REMARK
5795	96.34	96.42	/	/	34.68	11.67	46.43	100	330	Peak
5795	89.99	90.07	/	/	34.68	11.67	46.43	100	330	Average

ANTENNA POLARITY & TEST DISTANCE: VERTICAL AT 3 M

FREQ. (MHz)	EMISSION LEVEL (dBuV/m)	READ LEVEL (dBuV)	LIMIT (dBuV/m)	MARGIN (dB)	ANTENNA FACTOR (dB /m)	CABLE LOSS (dB)	PREAMP FACTOR (dB)	ANTENNA HEIGHT (cm)	TABLE ANGLE (Degree)	REMARK
5795	90.55	90.46	/	/	34.85	11.67	46.43	100	60	Peak
5795	84.37	84.28	/	/	34.85	11.67	46.43	100	60	Average

REMARKS:

- Emission Level = Read Level+ Antenna Factor + Cable Loss- Preamp Factor
Margin value = Emission level – Limit value.
- 5795MHz: Fundamental frequency.



Oobe Data

802.11n (40MHz)

ANTENNA POLARITY & TEST DISTANCE: HORIZONTAL AT 3 M											
FREQ. (MHz)	EMISSION LEVEL (dBuV/m)	READ LEVEL (dBuV)	LIMIT (dBuV/m)	MARGIN (dB)	ANTENNA FACTOR (dB /m)	CABLE LOSS (dB)	PREAMP FACTOR (dB)	ANTENNA HEIGHT (cm)	TABLE ANGLE (Degree)	REMARK	
5590.375	57.91	58.5	68.2	-10.29	34.3	11.59	46.48	100	360	Peak	
6003.15	59.28	58.8	68.2	-8.92	35.11	11.75	46.38	100	360	Peak	
ANTENNA POLARITY & TEST DISTANCE: VERTICAL AT 3 M											
FREQ. (MHz)	EMISSION LEVEL (dBuV/m)	READ LEVEL (dBuV)	LIMIT (dBuV/m)	MARGIN (dB)	ANTENNA FACTOR (dB /m)	CABLE LOSS (dB)	PREAMP FACTOR (dB)	ANTENNA HEIGHT (cm)	TABLE ANGLE (Degree)	REMARK	
5574.7	59.43	59.43	68.2	-8.77	34.9	11.59	46.49	100	0	Peak	
6004.1	59.49	59.08	68.2	-8.71	35.03	11.76	46.38	100	0	Peak	

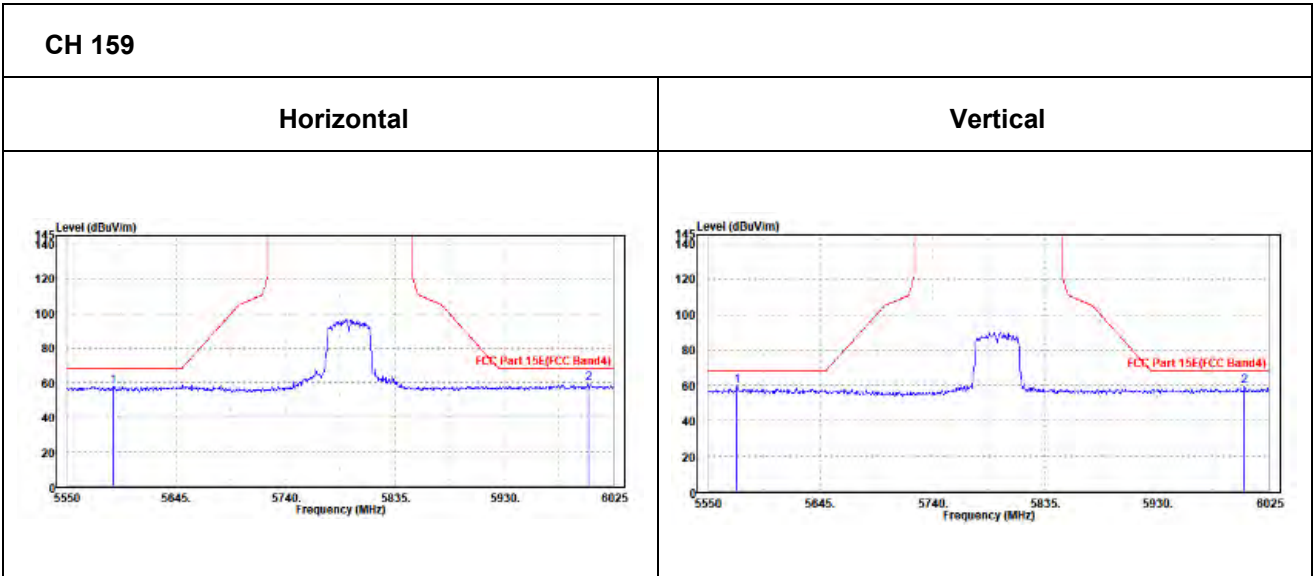



802.11ac (80MHz)

CHANNEL	TX Channel 155	DETECTOR FUNCTION	Peak (PK)
FREQUENCY RANGE	1GHz ~ 40GHz		Average (AV)

ANTENNA POLARITY & TEST DISTANCE: HORIZONTAL AT 3 M

FREQ. (MHz)	EMISSION LEVEL (dBuV/m)	READ LEVEL (dBuV)	LIMIT (dBuV/m)	MARGIN (dB)	ANTENNA FACTOR (dB /m)	CABLE LOSS (dB)	PREAMP FACTOR (dB)	ANTENNA HEIGHT (cm)	TABLE ANGLE (Degree)	REMARK
5775	92.64	92.82	/	/	34.6	11.66	46.44	100	330	Peak
5775	86.12	86.3	/	/	34.6	11.66	46.44	100	330	Average

ANTENNA POLARITY & TEST DISTANCE: VERTICAL AT 3 M

FREQ. (MHz)	EMISSION LEVEL (dBuV/m)	READ LEVEL (dBuV)	LIMIT (dBuV/m)	MARGIN (dB)	ANTENNA FACTOR (dB /m)	CABLE LOSS (dB)	PREAMP FACTOR (dB)	ANTENNA HEIGHT (cm)	TABLE ANGLE (Degree)	REMARK
5775	86.95	87.08	/	/	34.65	11.66	46.44	100	60	Peak
5775	81.44	81.57	/	/	34.65	11.66	46.44	100	60	Average

REMARKS:

- Emission Level = Read Level+ Antenna Factor + Cable Loss- Preamp Factor
Margin value = Emission level – Limit value.
- 5775MHz: Fundamental frequency.



Oobe Data

802.11ac (80MHz)

ANTENNA POLARITY & TEST DISTANCE: HORIZONTAL AT 3 M										
FREQ. (MHz)	EMISSION LEVEL (dBuV/m)	READ LEVEL (dBuV)	LIMIT (dBuV/m)	MARGIN (dB)	ANTENNA FACTOR (dB /m)	CABLE LOSS (dB)	PREAMP FACTOR (dB)	ANTENNA HEIGHT (cm)	TABLE ANGLE (Degree)	REMARK
5558.075	57.8	58.41	68.2	-10.4	34.3	11.58	46.49	100	360	Peak
5939.975	57.98	57.57	68.2	-10.22	35.08	11.73	46.4	100	360	Peak
ANTENNA POLARITY & TEST DISTANCE: VERTICAL AT 3 M										
FREQ. (MHz)	EMISSION LEVEL (dBuV/m)	READ LEVEL (dBuV)	LIMIT (dBuV/m)	MARGIN (dB)	ANTENNA FACTOR (dB /m)	CABLE LOSS (dB)	PREAMP FACTOR (dB)	ANTENNA HEIGHT (cm)	TABLE ANGLE (Degree)	REMARK
5620.775	58.01	58.02	68.2	-10.19	34.85	11.61	46.47	100	0	Peak
6013.6	60.12	59.62	68.2	-8.08	35.11	11.77	46.38	100	0	Peak

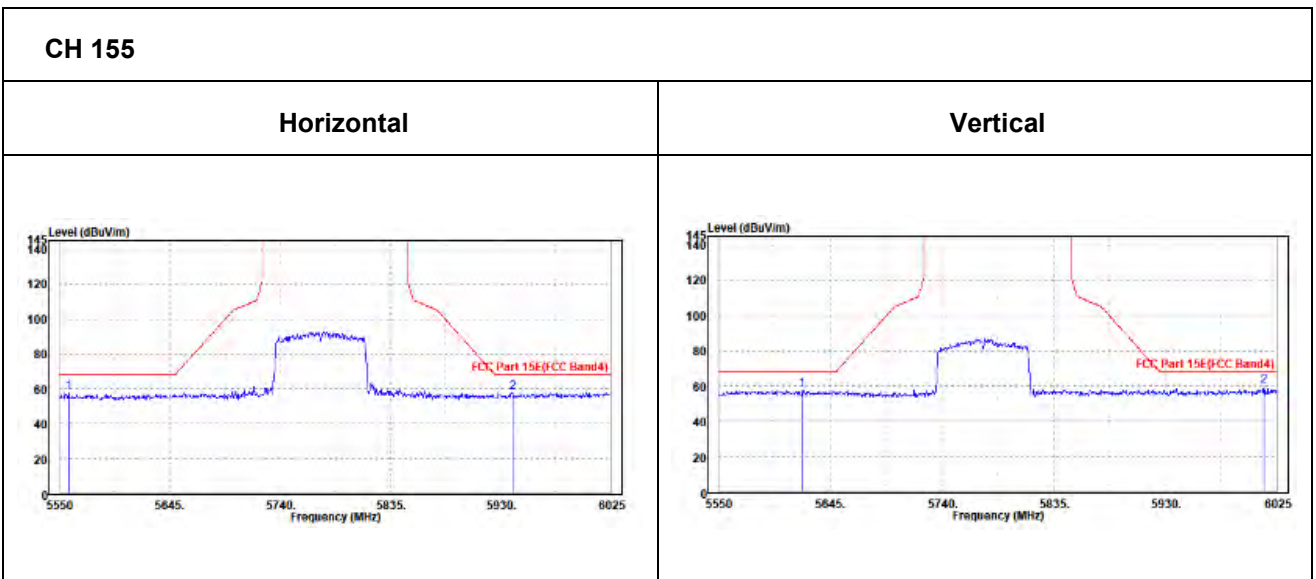



802.11ac (80MHz)

Worst case harmonic:

CHANNEL	TX Channel 155	DETECTOR FUNCTION	Peak (PK)
FREQUENCY RANGE	1GHz ~ 40GHz		Average (AV)

ANTENNA POLARITY & TEST DISTANCE: HORIZONTAL AT 3 M

	Freq	Level	Read Level	Limit Line	Over Limit	Factor	Remark	Pol/Phase
	MHz	dBuV/m	dBuV	dBuV/m	dB	dB/m		
1	11557.000	52.51	44.46	74.00	-21.49	8.05	Peak	Horizontal
2	11557.000	44.53	36.48	54.00	-9.47	8.05	Average	Horizontal
3	PK17325.000	57.71	40.87	74.00	-16.29	16.84	Peak	Horizontal
4	PP17325.000	49.69	32.85	54.00	-4.31	16.84	Average	Horizontal

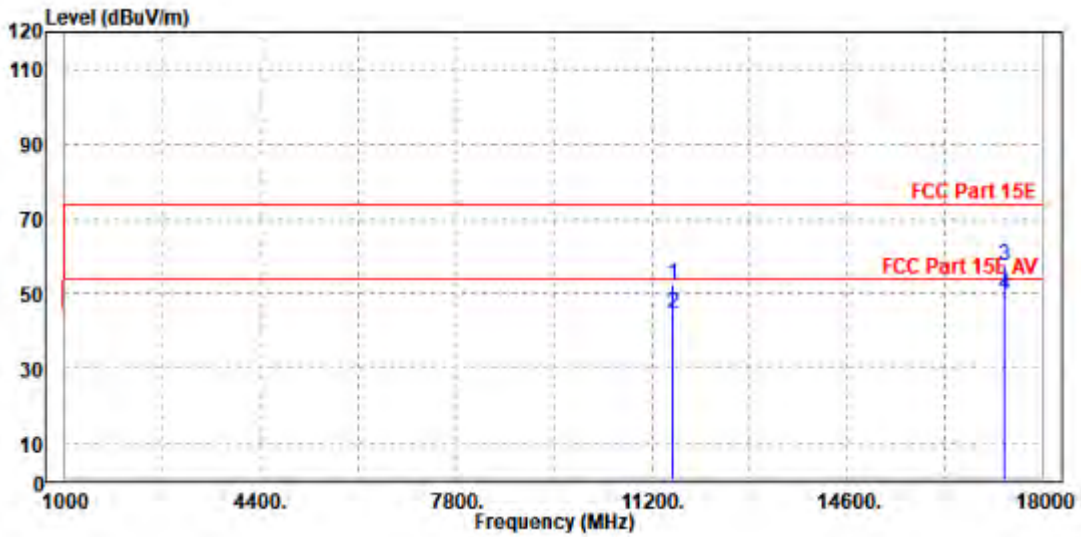



ANTENNA POLARITY & TEST DISTANCE: VERTICAL AT 3 M

	Freq	Level	Read Level	Limit Line	Over Limit	Factor	Remark	Pol/Phase
	MHz	dBuV/m	dBuV	dBuV/m	dB	dB/m		
1	11550.000	52.95	45.45	74.00	-21.05	7.50	Peak	Vertical
2	11550.000	44.66	37.16	54.00	-9.34	7.50	Average	Vertical
3	PK17320.000	57.54	41.62	74.00	-16.46	15.92	Peak	Vertical
4	PP17320.000	47.88	31.96	54.00	-6.12	15.92	Average	Vertical

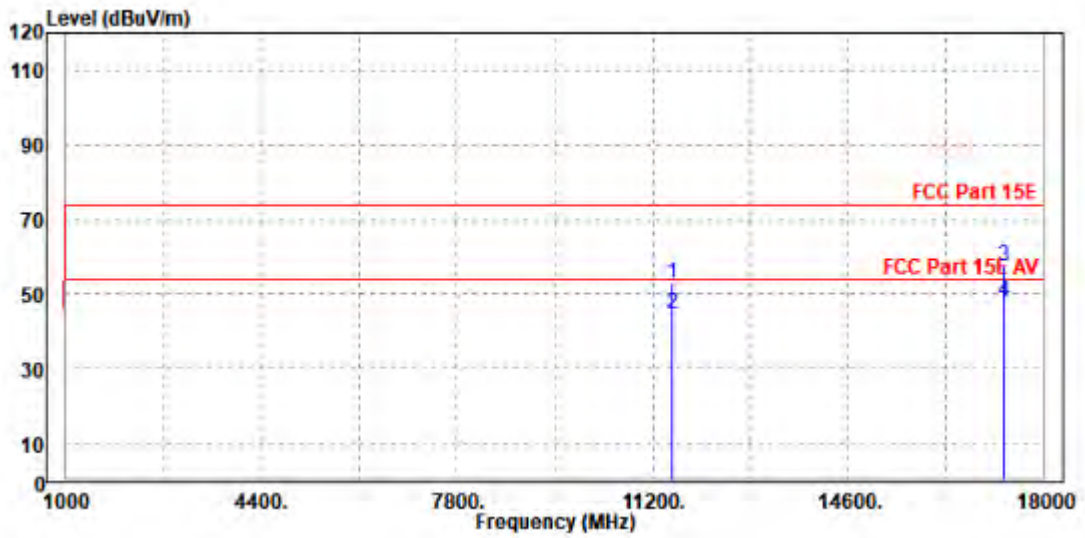

REMARKS:

1. Emission Level = Read Level+ Antenna Factor + Cable Loss- Preamp Factor
Margin value = Emission level – Limit value.
2. 5775MHz: Fundamental frequency.
3. For frequency above 18GHz, the emission was tested 20db below the limit so the data not recorded in the sheet.



3.2 CONDUCTED EMISSION MEASUREMENT

3.2.1 LIMITS OF CONDUCTED EMISSION MEASUREMENT

FREQUENCY OF EMISSION (MHz)	CONDUCTED LIMIT (dBµV)	
	Quasi-peak	Average
0.15 ~ 0.5	66 to 56	56 to 46
0.5 ~ 5	56	46
5 ~ 30	60	50

- NOTE:**
1. The lower limit shall apply at the transition frequencies.
 2. The limit decreases in line with the logarithm of the frequency in the range of 0.15 to 0.50MHz.
 3. All emanations from a class A/B digital device or system, including any network of conductors and apparatus connected thereto, shall not exceed the level of field strengths specified above.

3.2.2 TEST INSTRUMENTS

Equipment	Manufacturer	Model No.	Serial No.	Last Cal.	Next Cal.
EMI Test Receiver	Rohde&Schwarz	ESR3	101900	Feb. 14,24	Feb. 13,25
EMC32 test software	Rohde&Schwarz	EMC32	NA	NA	NA
LISN network	Rohde&Schwarz	ENV216	101922	Mar. 10,24	Mar. 09,25

- NOTE:**
1. The test was performed in CE shielded room.
 2. The calibration interval of the above test instruments is 12 months. And the calibrations are traceable to CEPREI/CHINA, GRGT/CHINA and NIM/CHINA.

3.2.3 TEST PROCEDURES

- a. The EUT was placed 0.4 meters from the conducting wall of the shielded room with EUT being connected to the power mains through a line impedance stabilization network (LISN). Other support units were connected to the power mains through another LISN. The two LISNs provide 50 ohm/ 50uH of coupling impedance for the measuring instrument.
- b. Both lines of the power mains connected to the EUT were checked for maximum conducted interference.
- c. The frequency range from 150kHz to 30MHz was searched. Emission levels under (Limit - 20dB) was not recorded.

NOTE: All modes of operation were investigated and the worst-case emissions are reported.



3.2.4 DEVIATION FROM TEST STANDARD

No deviation.

3.2.5 TEST SETUP

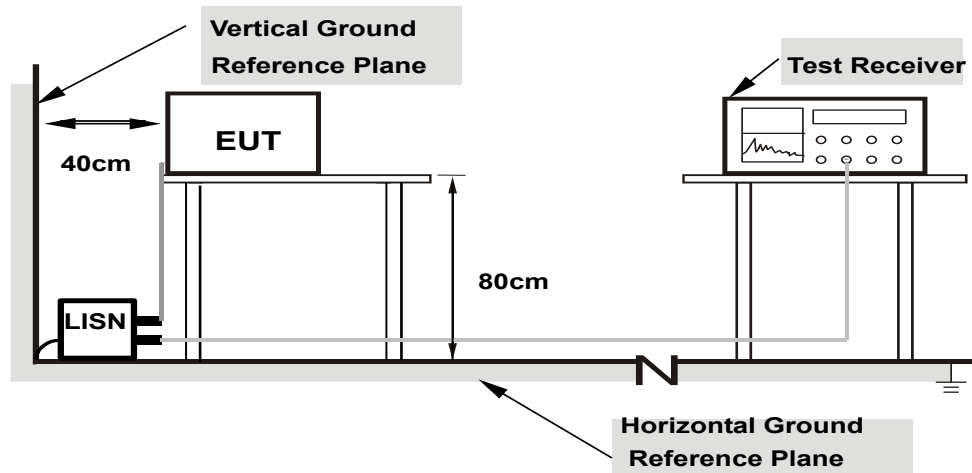

- Note:**
- 1.Support units were connected to second LISN.
 - 2.Both of LISNs (AMN) are 80 cm from EUT and at least 80 from other units and other metal planes

For the actual test configuration, please refer to the attached file (Test Setup Photo).

3.2.6 EUT OPERATING CONDITIONS

Same as 3.1.7.



3.2.7 TEST RESULTS

CONDUCTED WORST-CASE DATA:

Frequency Range	150KHz ~ 30MHz	Detector Function & Resolution Bandwidth	Quasi-Peak (QP) / Average (AV), 9 kHz
Input Power	120Vac, 60Hz	Environmental Conditions	26deg. C, 51%RH
Tested By	Carl Xie		

Frequency (MHz)	QuasiPeak (dBuV)	CAverage (dBuV)	Limit (dBuV)	Margin (dB)	Line	Filter	Corr. (dB)
0.460000	---	27.89	46.69	18.80	L1	ON	9.8
0.460000	39.29	---	56.69	17.40	L1	ON	9.8
1.204000	---	27.47	46.00	18.53	L1	ON	9.8
1.204000	37.52	---	56.00	18.48	L1	ON	9.8
1.412000	---	26.65	46.00	19.35	L1	ON	9.8
1.412000	35.98	---	56.00	20.02	L1	ON	9.8
2.712000	---	15.84	46.00	30.16	L1	ON	9.9
2.712000	24.31	---	56.00	31.69	L1	ON	9.9
4.672000	---	23.15	46.00	22.85	L1	ON	9.7
4.672000	31.38	---	56.00	24.62	L1	ON	9.7
16.596000	---	23.03	50.00	26.97	L1	ON	11.0
16.596000	32.19	---	60.00	27.81	L1	ON	11.0

- REMARKS:**
1. Q.P. and AV. are abbreviations of quasi-peak and average individually.
 2. "-": The Quasi-peak reading value also meets average limit and measurement with the average detector is unnecessary.
 3. The emission levels of other frequencies were very low against the limit.
 4. Margin value = Limit value - Emission level
 5. Correction factor = Insertion loss + Cable loss
 6. Emission Level = Correction Factor + Reading Value.

Full Spectrum

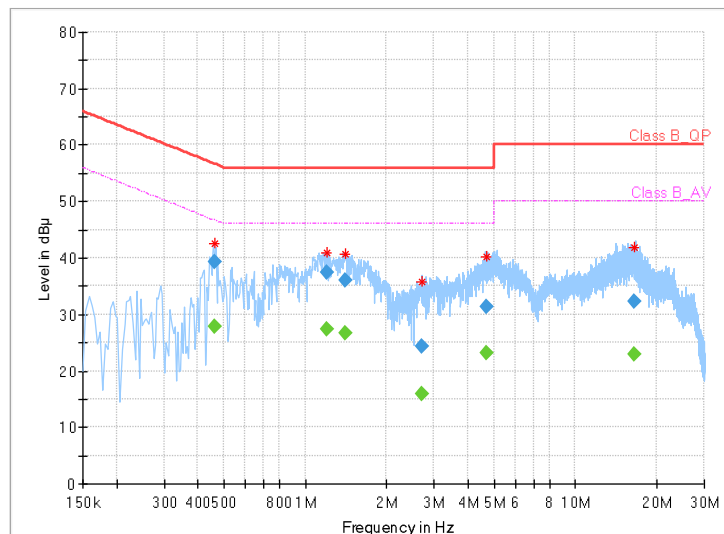



**BUREAU
VERITAS**

Test Report No.: W7L-240618W002RF03

Frequency Range	150KHz ~ 30MHz	Detector Function & Resolution Bandwidth	Quasi-Peak (QP) / Average (AV), 9 kHz
Input Power	120Vac, 60Hz	Environmental Conditions	26deg. C, 51%RH
Tested By	Carl Xie		

Frequency (MHz)	QuasiPeak (dBuV)	CAverage (dBuV)	Limit (dBuV)	Margin (dB)	Line	Filter	Corr. (dB)
0.456000	---	31.29	46.77	15.48	N	ON	9.6
0.456000	45.28	---	56.77	11.49	N	ON	9.6
0.992000	---	29.07	46.00	16.93	N	ON	9.7
0.992000	39.25	---	56.00	16.75	N	ON	9.7
1.460000	---	20.48	46.00	25.52	N	ON	9.7
1.460000	33.24	---	56.00	22.76	N	ON	9.7
4.732000	---	26.70	46.00	19.30	N	ON	9.7
4.732000	36.22	---	56.00	19.78	N	ON	9.7
9.748000	---	29.29	50.00	20.71	N	ON	10.4
9.748000	35.91	---	60.00	24.09	N	ON	10.4
15.204000	---	30.59	50.00	19.41	N	ON	10.9
15.204000	38.39	---	60.00	21.61	N	ON	10.9

- REMARKS:**
1. Q.P. and AV. are abbreviations of quasi-peak and average individually.
 2. "-": The Quasi-peak reading value also meets average limit and measurement with the average detector is unnecessary.
 3. The emission levels of other frequencies were very low against the limit.
 4. Margin value = Limit value - Emission level
 5. Correction factor = Insertion loss + Cable loss
 6. Emission Level = Correction Factor + Reading Value.

Full Spectrum

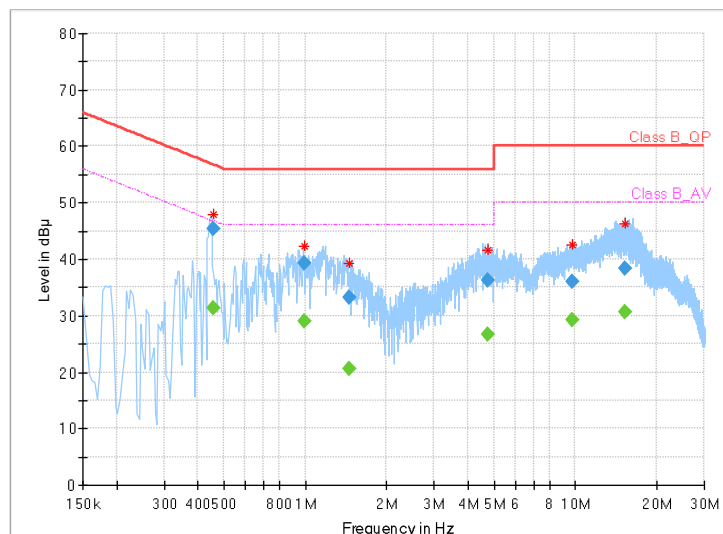



3.3 MAXIMUM CONDUCTED OUTPUT POWER MEASUREMENT

3.3.1 LIMITS OF MAXIMUM CONDUCTED OUTPUT POWER MEASUREMENT

Operation Band	EUT Category		LIMIT
U-NII-1		Outdoor Access Point	1 Watt (30 dBm) (Max. e.i.r.p \leq 125mW(21 dBm) at any elevation angle above 30 degrees as measured from the horizon)
		Fixed point-to-point Access Point	1 Watt (30 dBm)
	B	Indoor Access Point	1 Watt (30 dBm)
	√	Client devices	250mW (24 dBm)
U-NII-2A	√		250mW (24 dBm) or 11 dBm+10 log B*
U-NII-2C	√		250mW (24 dBm) or 11 dBm+10 log B*
U-NII-3	√		1 Watt (30 dBm)

NOTE: Where B is the 26dB emission bandwidth in MHz.



3.3.2 TEST SETUP

FOR POWER OUTPUT MEASUREMENT

802.11a, 802.11n/ac (20MHz), 802.11 n/ac (40MHz),802.11ac (80MHz) TEST CONFIGURATION

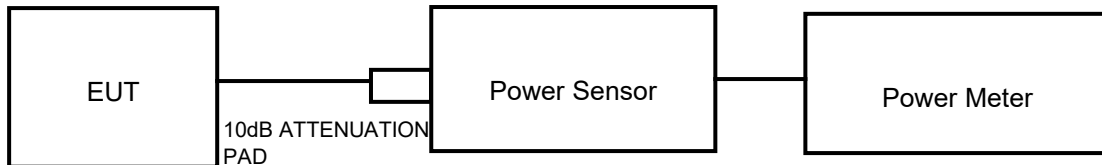

FOR 26dB BANDWIDTH

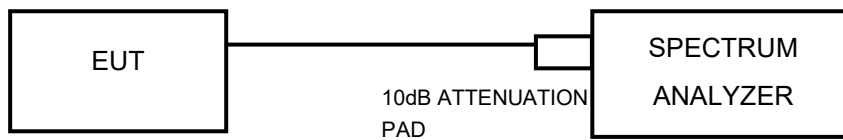

3.3.3 TEST INSTRUMENTS

Equipment	Manufacturer	Model No.	Serial No.	Last Cal.	Next Cal.
Power Meter	ANRITSU	ML2495A	1506002	Feb. 14,24	Feb. 13,25
EXA Signal Analyzer	KEYSIGHT	N9010A-526	MY54510523	Feb. 14,24	Feb. 13,25
EXA Signal Analyzer	KEYSIGHT	N9010A-544	MY54510355	May.10,24	May.09,25
Power Sensor	ANRITSU	MA2411B	1339352	Feb. 14,24	Feb. 13,25

NOTE:

1. The calibration interval of the above test instruments is 12 months, and the calibrations are traceable to CEPREI/CHINA, GRGT/CHINA and NIM/CHINA.
2. The test was performed in the RF Oven room.



3.3.4 TEST PROCEDURE

FOR POWER MEASUREMENT

For 802.11a, 802.11 n/ac (20MHz), 802.11 n/ac (40MHz) , 802.11 ac (80MHz)

Method PM is used to perform output power measurement, trigger and gating function of wide band power meter is enabled to measure max output power of TX on burst. Duty factor is not added to measured value.

FOR 99 PERCENT OCCUPIED BANDWIDTH

The following procedure shall be used for measuring (99 %) power bandwidth:

1. Set center frequency to the nominal EUT channel center frequency.
2. Set span = 1.5 times to 5.0 times the OBW.
3. Set RBW = 1 % to 5 % of the OBW
4. Set VBW $\geq 3 \cdot$ RBW
5. Video averaging is not permitted. Where practical, a sample detection and single sweep mode shall be used. Otherwise, peak detection and max hold mode (until the trace stabilizes) shall be used.
6. Use the 99 % power bandwidth function of the instrument (if available).
7. If the instrument does not have a 99 % power bandwidth function, the trace data points are recovered and directly summed in power units. The recovered amplitude data points, beginning at the lowest frequency, are placed in a running sum until 0.5 % of the total is reached; that frequency is recorded as the lower frequency. The process is repeated until 99.5 % of the total is reached; that frequency is recorded as the upper frequency. The 99% occupied bandwidth is the difference between these two frequencies.

FOR 26dB BANDWIDTH

- 1) Set RBW = approximately 1% of the emission bandwidth.
- 2) Set the VBW > RBW.
- 3) Detector = Peak.
- 4) Trace mode = max hold.
- 5) Measure the maximum width of the emission that is 26 dB down from the peak of the emission. Compare this with the RBW setting of the analyzer. Readjust RBW and repeat measurement as needed until the RBW/EBW ratio is approximately 1%.



FOR 6dB BANDWIDTH

1. Set RBW = 100 kHz.
2. Set the video bandwidth (VBW) ≥ 3 RBW.
3. Detector = Peak.
4. Trace mode = max hold.
5. Sweep = auto couple.
6. Allow the trace to stabilize.
7. Measure the maximum width of the emission that is constrained by the frequencies associated with the two outermost amplitude points (upper and lower frequencies) that are attenuated by 6 dB relative to the maximum level measured in the fundamental emission.



3.3.5 DEVIATION FROM TEST STANDARD

No deviation.

3.3.6 EUT OPERATING CONDITIONS

The software provided by the client to enable the EUT under transmission condition continuously at specific channel frequencies individually.



BUREAU VERITAS Test Report No.: W7L-240618W002RF03

3.3.7 TEST RESULTS

Please Refer to Appendix Of this test report.



3.4 MAXIMUM POWER SPECTRAL DENSITY MEASUREMENT

3.4.1 LIMITS OF MAXIMUM POWER SPECTRAL DENSITY MEASUREMENT

Operation Band	EUT Category		LIMIT
U-NII-1		Outdoor Access Point	17dBm/ MHz
		Fixed point-to-point Access Point	
		Indoor Access Point	
	√	Client devices	11dBm/ MHz
U-NII-2A	√		11dBm/ MHz
U-NII-2C	√		11dBm/ MHz
U-NII-3	√		30dBm/ 500kHz

3.4.2 TEST SETUP

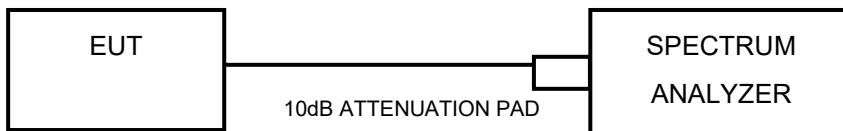

3.4.3 TEST INSTRUMENTS

Refer to section 3.3.3 to get information about the above instrument.



3.4.4 TEST PROCEDURES

Using method SA-2(Band1/2/3)

- 1) Set span to encompass the entire emission bandwidth (EBW) of the signal.
- 2) Set RBW = 1 MHz, Set VBW \geq 3 MHz, Detector = RMS
- 3) Set Channel power measure = 1MHz
- 4) Sweep time = auto, trigger set to "free run".
- 5) Trace average at least 100 traces in power averaging mode.
- 6) Add $10 \log(1/x)$, where x is the duty cycle, to the measured power in order to compute the average power during the actual transmission times (because the measurement represents an average over both the on and off times of the transmission).
- 7) Record the max value

Using method SA-2 (Band4)

- 1) Set span to encompass the entire emission bandwidth (EBW) of the signal.
- 2) Set RBW = 300 KHz, Set VBW \geq 1 MHz, Detector = RMS
- 3) Set Channel power measure = 1MHz
- 4) Sweep time = auto, trigger set to "free run".
- 5) Trace average at least 100 traces in power averaging mode.
- 6) Add $10 \log(500\text{kHz}/\text{RBW})$ to the test result. $10 \log(500\text{kHz}/300\text{KHZ}) = 2.22\text{dBm}$
- 7) Add $10 \log(1/x)$, where x is the duty cycle, to the measured power in order to compute the average power during the actual transmission times (because the measurement represents an average over both the on and off times of the transmission).
- 8) Record the max value

3.4.5 DEVIATION FROM TEST STANDARD

No deviation.

3.4.6 EUT OPERATING CONDITIONS

Same as 3.1.7.



Test Report No.: W7L-240618W002RF03

3.4.7 TEST RESULTS

Please Refer to Appendix Of this test report.



3.5 AUTOMATICALLY DISCONTINUE TRANSMISSION

3.5.1 LIMIT OF AUTOMATICALLY DISCONTINUE TRANSMISSION

The device shall automatically discontinue transmission in case of either absence of information to transmit or operational failure. These provisions are not intended to preclude the transmission of control or signaling information, or the use of repetitive codes used by certain digital technologies to complete frame or burst intervals. Applicants shall include in their application for equipment authorization a description of how this requirement is met.

3.5.2 TEST INSTRUMENTS

Refer to section 3.3.3 to get information about the above instrument.

3.5.3 TEST RESULT

While the EUT is not transmitting any information, the EUT can automatically discontinue transmission and become standby mode for power saving。 The EUT can detect the controlling of ACK message transmitting from remote device and verify whether it shall resend or discontinue transmission.



3.6 ANTENNA REQUIREMENTS

3.6.1 STANDARD APPLICABLE

If transmitting antenna directional gain is greater than 6 dBi, both the peak transmits power and the peak power spectral density shall be reduced by the amount in dB that the directional gain of the antenna exceeds 6 dBi.

3.6.2 ANTENNA CONNECTED CONSTRUCTION

An embedded-in antenna design is used.

3.6.3 ANTENNA GAIN

The antenna peak gain of EUT is less than 6 dBi. Therefore, it is not necessary to reduce maximum peak output power limit and PSD limit.

4 PHOTOGRAPHS OF THE TEST CONFIGURATION

Please refer to the attached file (Test Setup Photo).



Test Report No.: W7L-240618W002RF03

5 MODIFICATIONS RECORDERS FOR ENGINEERING CHANGES TO THE EUT BY THE LAB

No modifications were made to the EUT by the lab during the test.



6 APPENDIX

RLAN

EMISSION BANDWIDTH

TEST RESULT

TestMode	Antenna	Frequency [MHz]	26db EBW [MHz]	FL[MHz]	FH[MHz]	Limit[MHz]	Verdict
11A	Ant0	5180	20.652	5169.624	5190.276	---	---
	Ant0	5200	23.058	5188.321	5211.379	---	---
	Ant0	5240	20.150	5229.925	5250.075	---	---
	Ant0	5260	20.251	5249.925	5270.176	---	---
	Ant0	5300	20.351	5289.825	5310.176	---	---
	Ant0	5320	20.251	5309.925	5330.176	---	---
	Ant0	5500	20.150	5489.925	5510.075	---	---
	Ant0	5580	20.150	5569.825	5589.975	---	---
	Ant0	5700	20.752	5689.624	5710.376	---	---
	Ant0	5720	20.752	5709.824	5730.576	---	---
	Ant0	5745	20.351	5734.925	5755.276	---	---
	Ant0	5785	19.950	5775.025	5794.975	---	---
	Ant0	5825	20.150	5814.925	5835.075	---	---
11N20	Ant0	5180	20.451	5169.825	5190.276	---	---
	Ant0	5200	20.451	5189.825	5210.276	---	---
	Ant0	5240	20.551	5229.724	5250.275	---	---
	Ant0	5260	20.451	5249.724	5270.175	---	---
	Ant0	5300	20.551	5289.724	5310.275	---	---
	Ant0	5320	20.652	5309.624	5330.276	---	---
	Ant0	5500	20.551	5489.724	5510.275	---	---
	Ant0	5580	20.551	5569.724	5590.275	---	---
	Ant0	5700	20.451	5689.724	5710.175	---	---
	Ant0	5720	20.751	5709.724	5730.475	---	---
	Ant0	5745	20.652	5734.724	5755.376	---	---
	Ant0	5785	20.652	5774.624	5795.276	---	---
	Ant0	5825	20.451	5814.825	5835.276	---	---



11N40	Ant0	5190	40.301	5169.849	5210.150	---	---
	Ant0	5230	40.902	5209.549	5250.451	---	---
	Ant0	5270	40.752	5249.699	5290.451	---	---
	Ant0	5310	40.602	5289.670	5330.272	---	---
	Ant0	5510	40.752	5489.699	5530.451	---	---
	Ant0	5550	40.752	5529.549	5570.301	---	---
	Ant0	5670	40.602	5649.699	5690.301	---	---
	Ant0	5710	40.602	5689.699	5730.301	---	---
	Ant0	5755	40.451	5734.850	5775.301	---	---
	Ant0	5795	41.805	5774.248	5816.053	---	---
11AC80	Ant0	5210	117.868	5150.063	5267.931	---	---
	Ant0	5290	82.257	5249.122	5331.379	---	---
	Ant0	5530	89.279	5482.100	5571.379	---	---
	Ant0	5610	82.759	5568.621	5651.380	---	---
	Ant0	5690	82.759	5648.621	5731.380	---	---
	Ant0	5775	82.257	5734.122	5816.379	---	---



TEST GRAPHS

11A_Ant0_5180

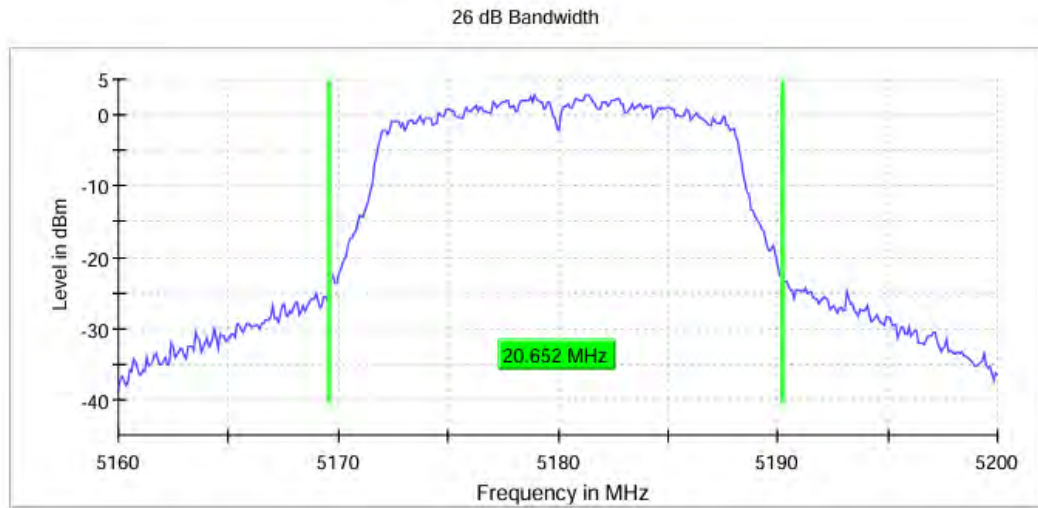

11A_Ant0_5200



11A_Ant0_5240

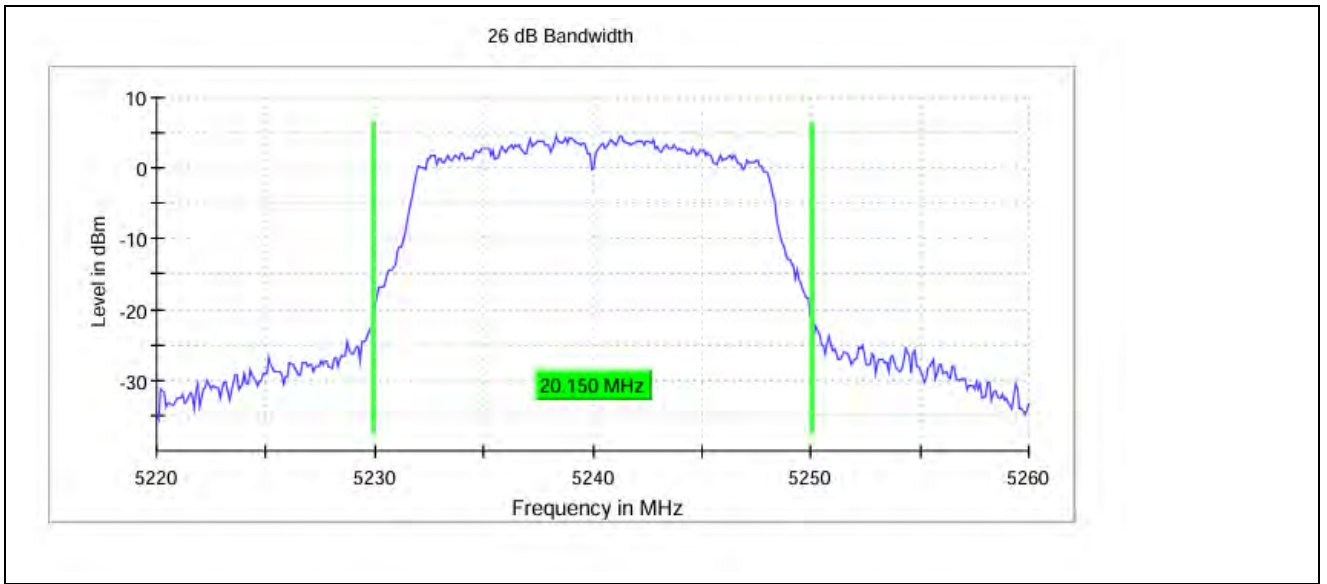

11A_Ant0_5260

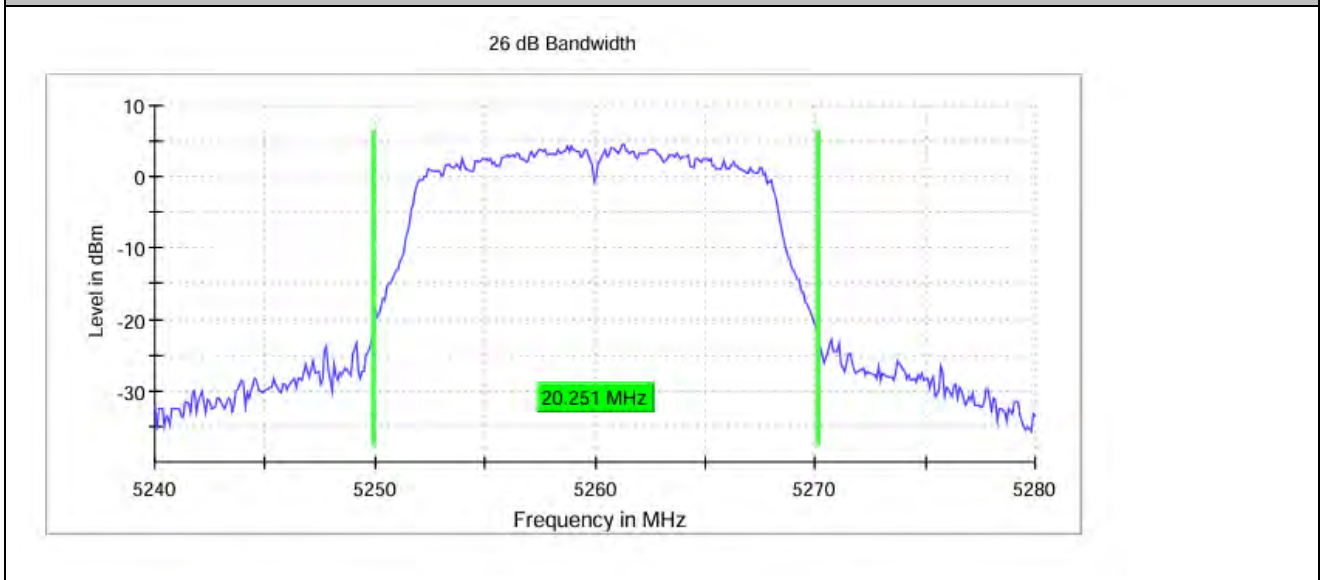

11A_Ant0_5300

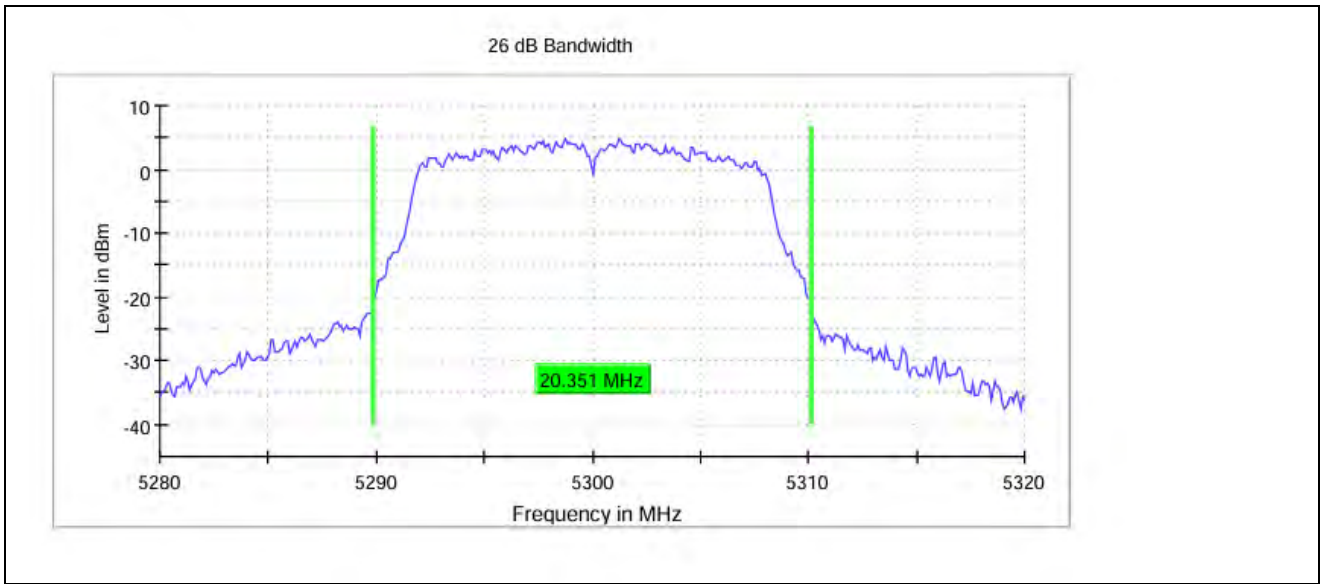

11A_Ant0_5320

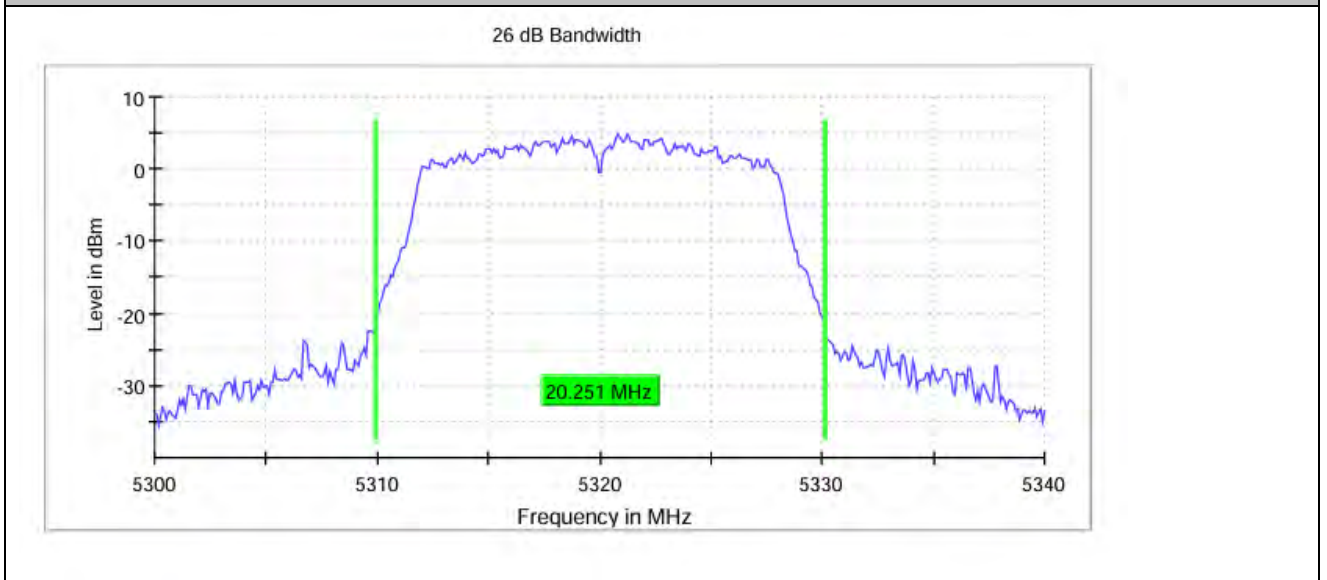

11A_Ant0_5500

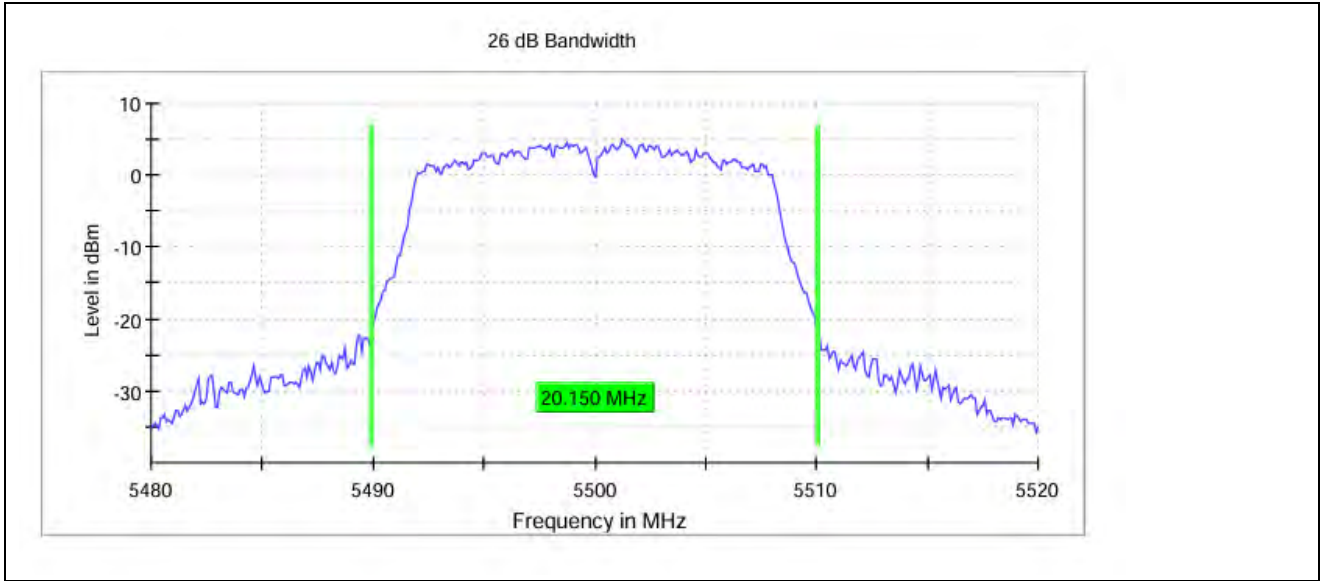

11A_Ant0_5580

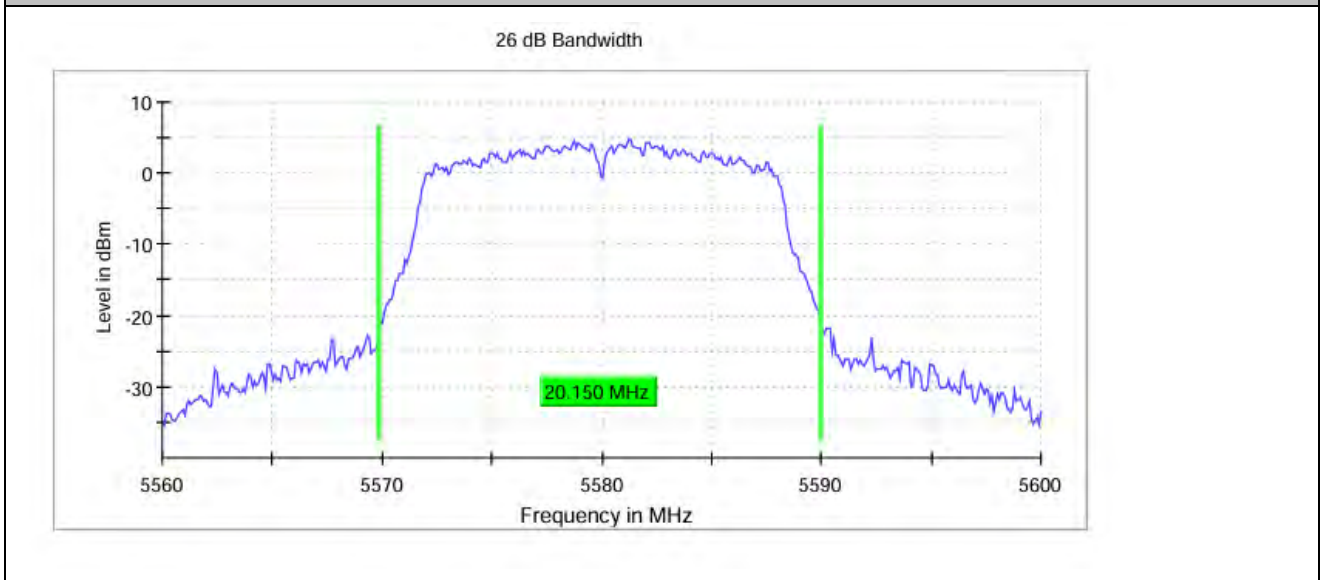

11A_Ant0_5700

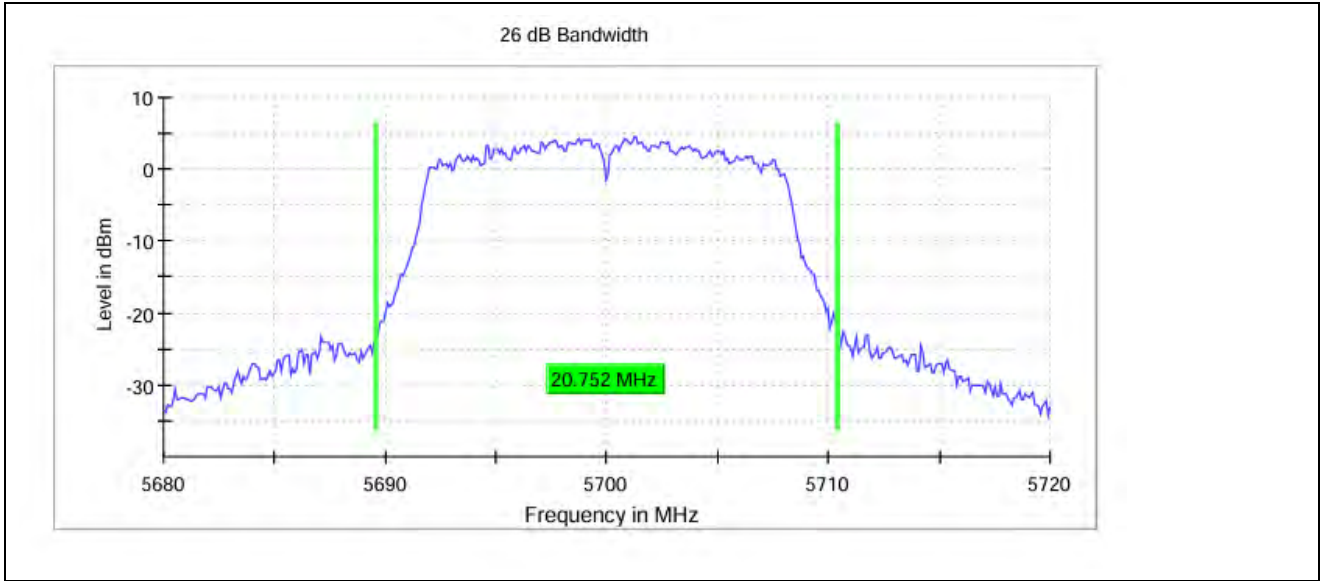

11A_Ant0_5720

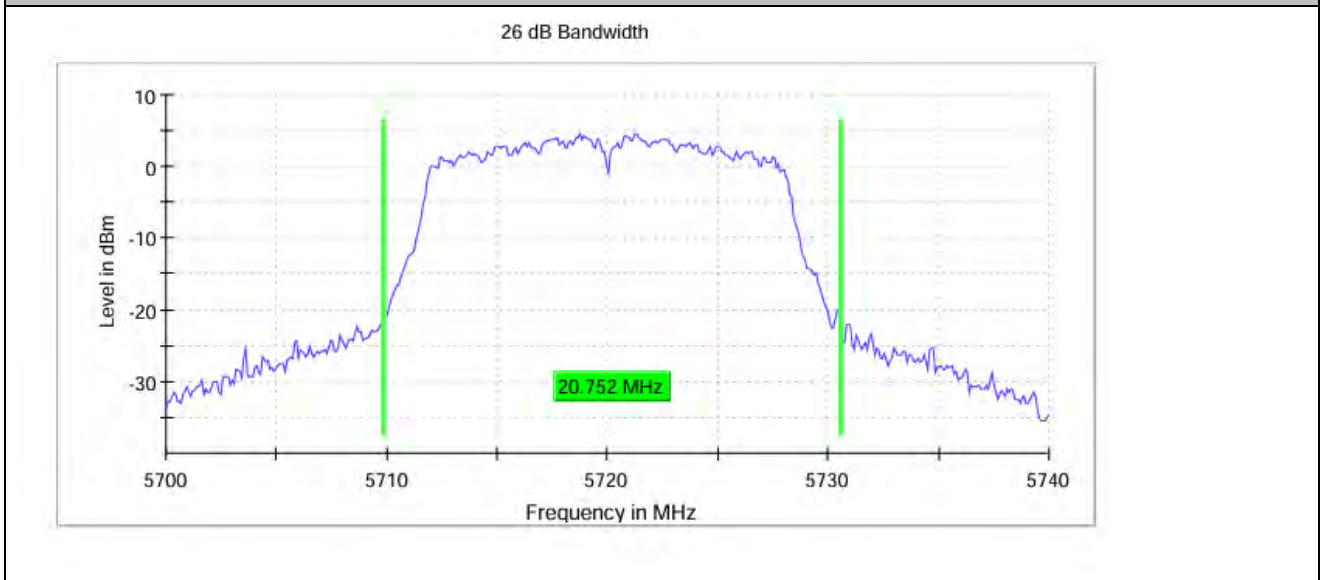

11A_Ant0_5745



BUREAU
VERITAS

Test Report No.: W7L-240618W002RF03

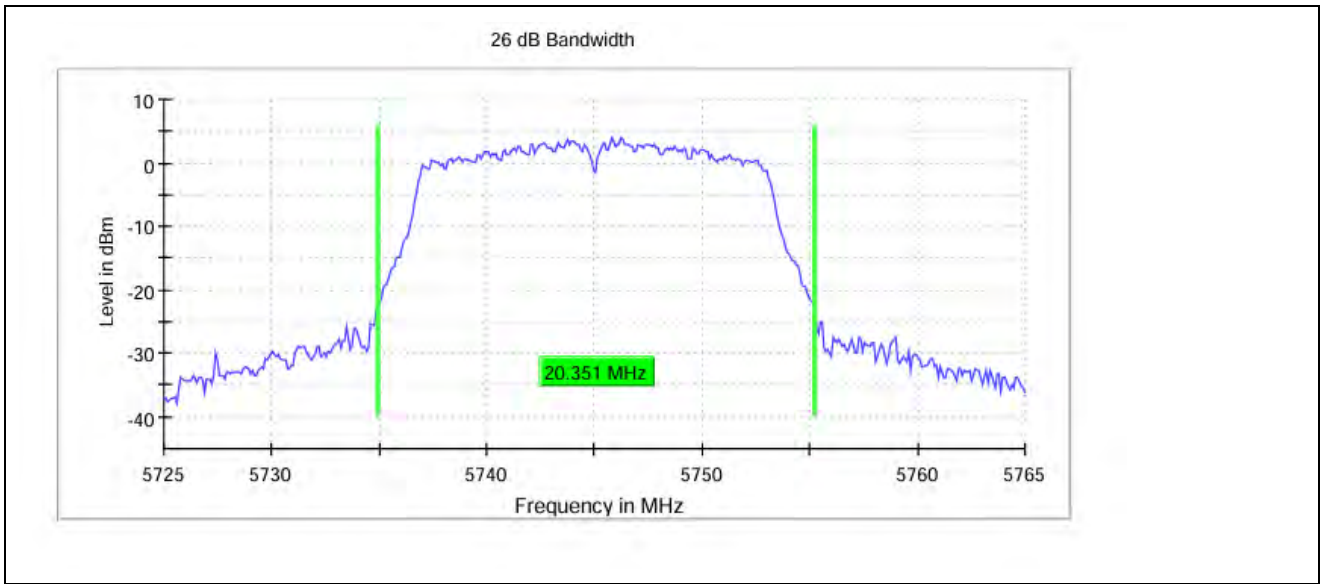

11A_Ant0_5785

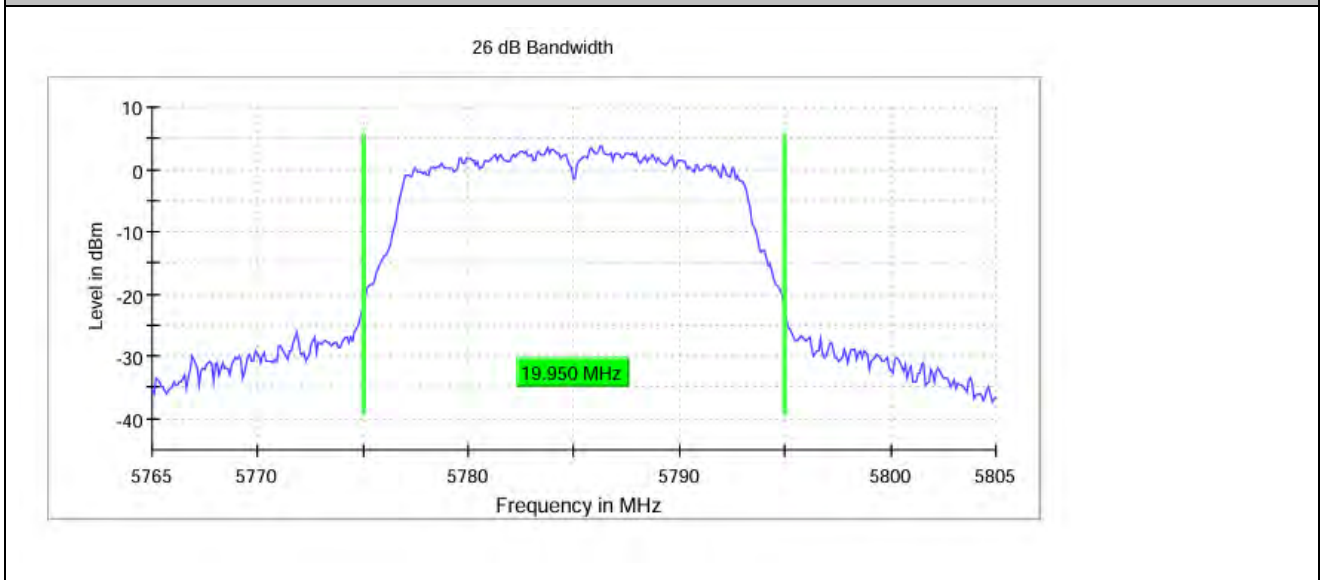

11A_Ant0_5825

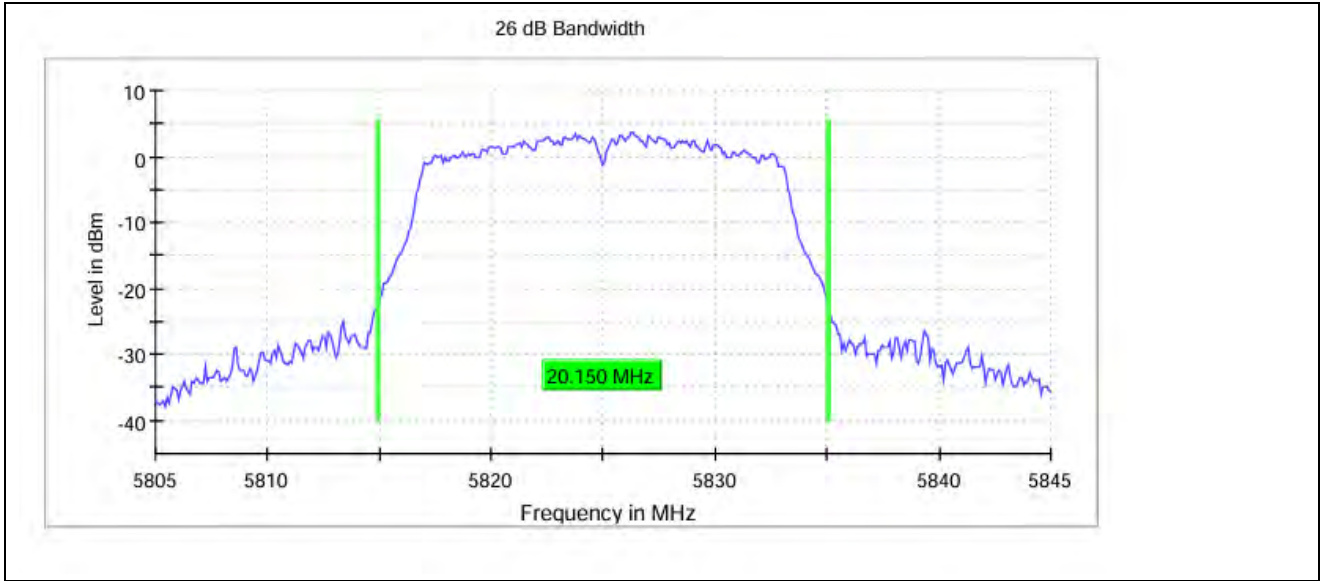

11N20_Ant0_5180

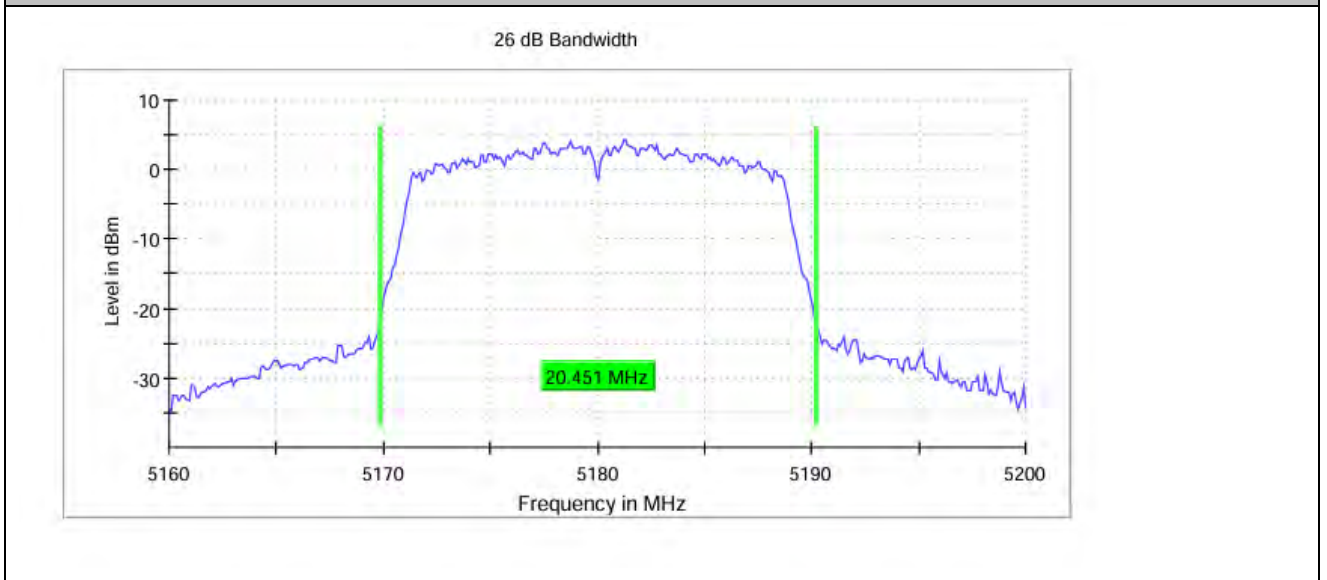

11N20_Ant0_5200

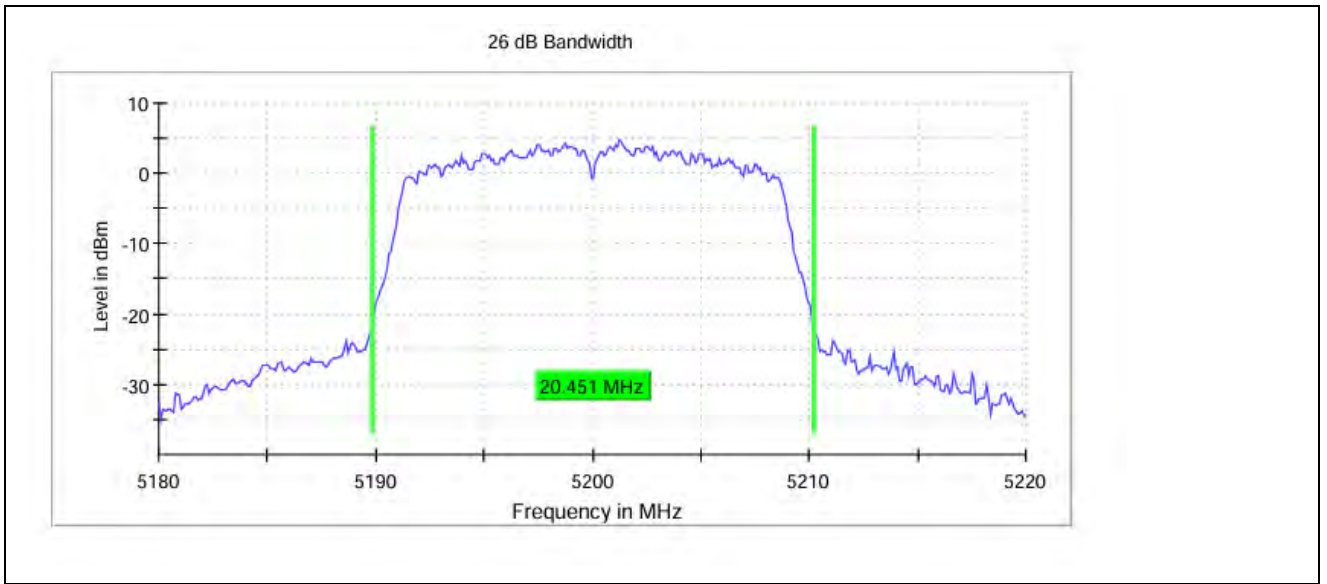

11N20_Ant0_5240

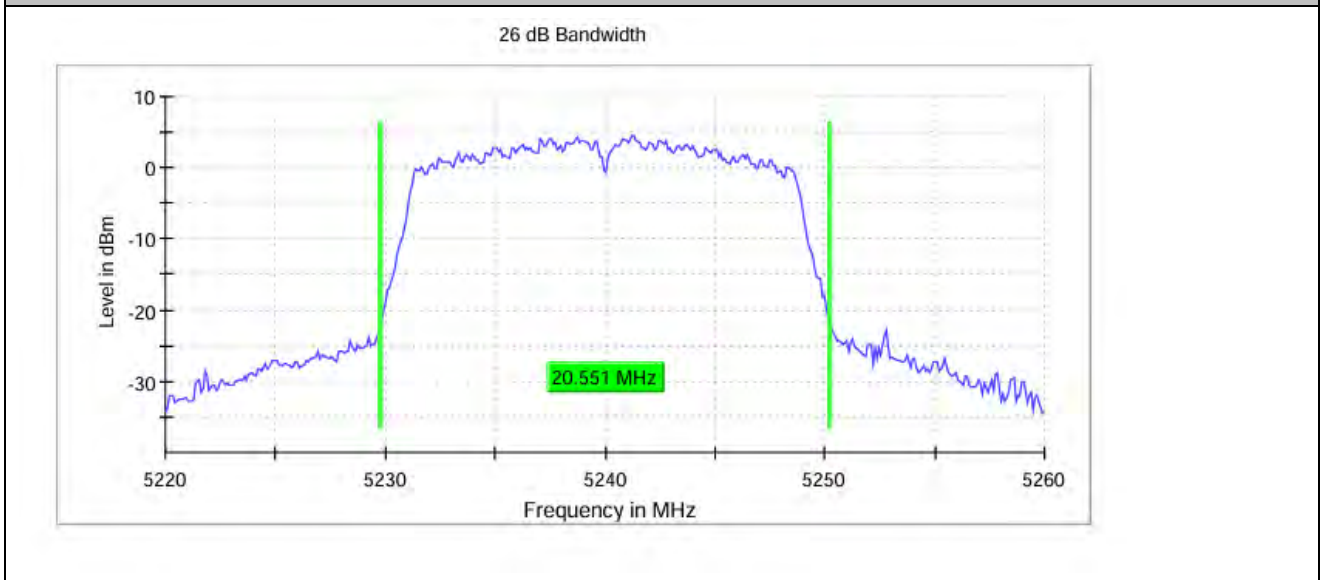

11N20_Ant0_5260



BUREAU
VERITAS

Test Report No.: W7L-240618W002RF03

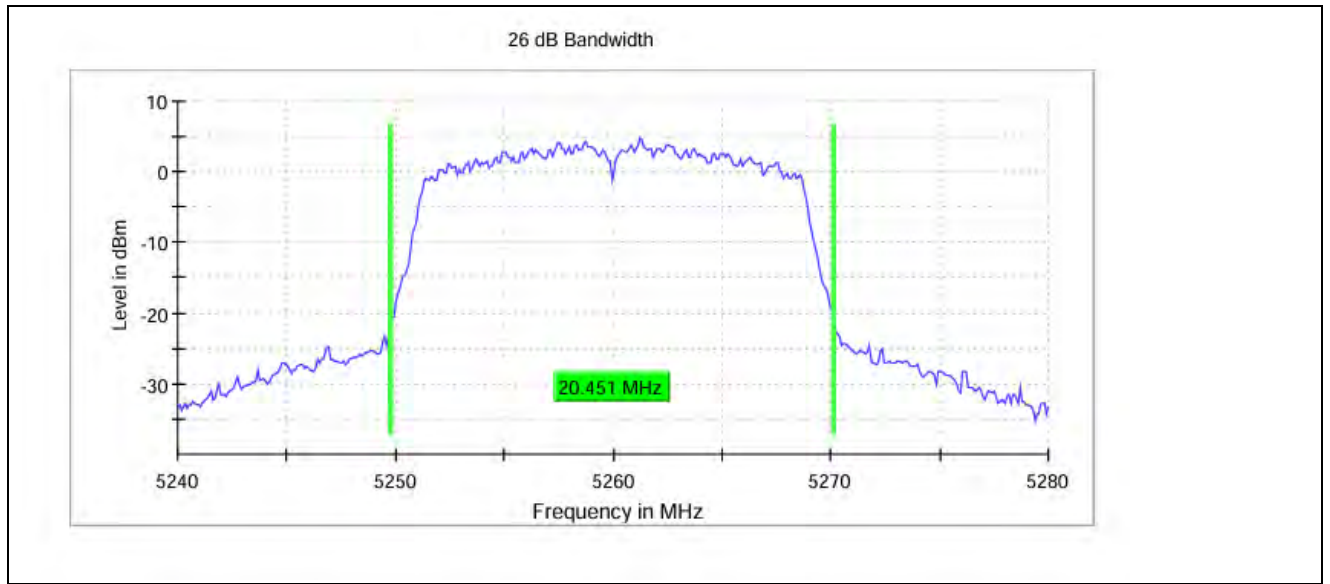

11N20_Ant0_5300

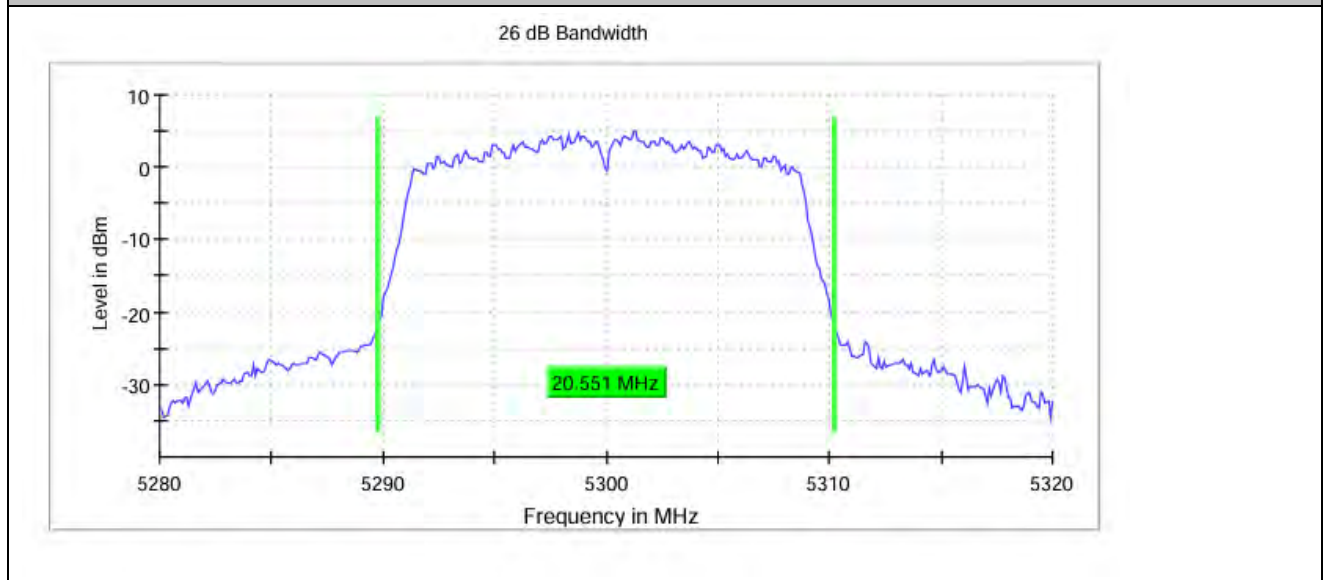

11N20_Ant0_5320



BUREAU
VERITAS

Test Report No.: W7L-240618W002RF03

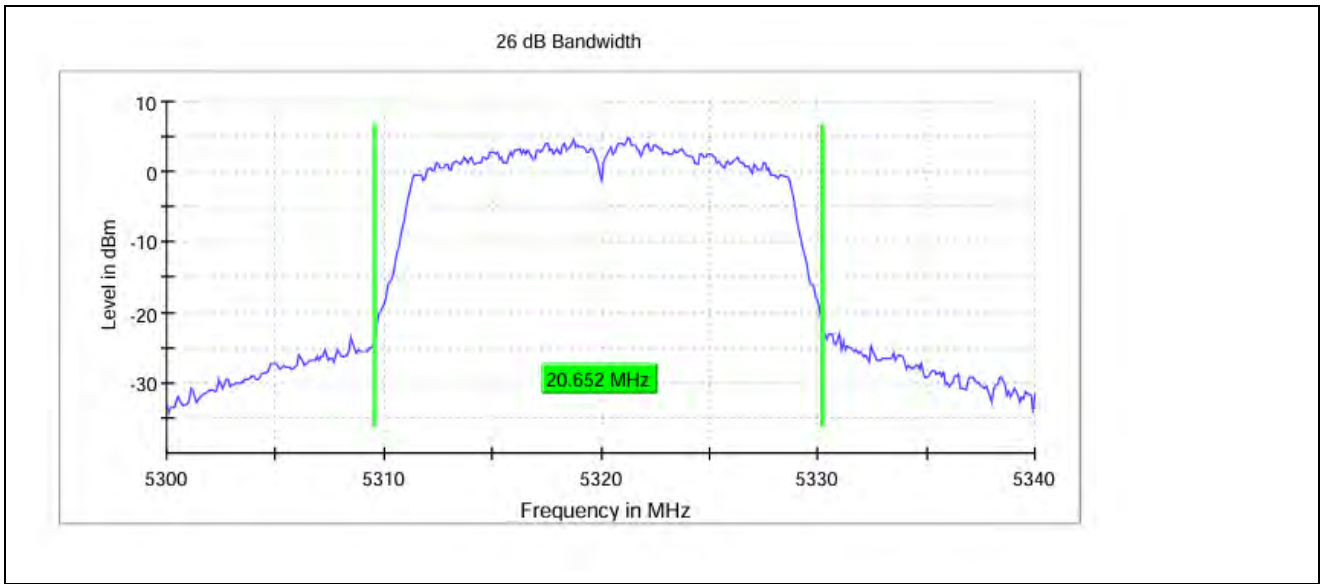

11N20_Ant0_5500

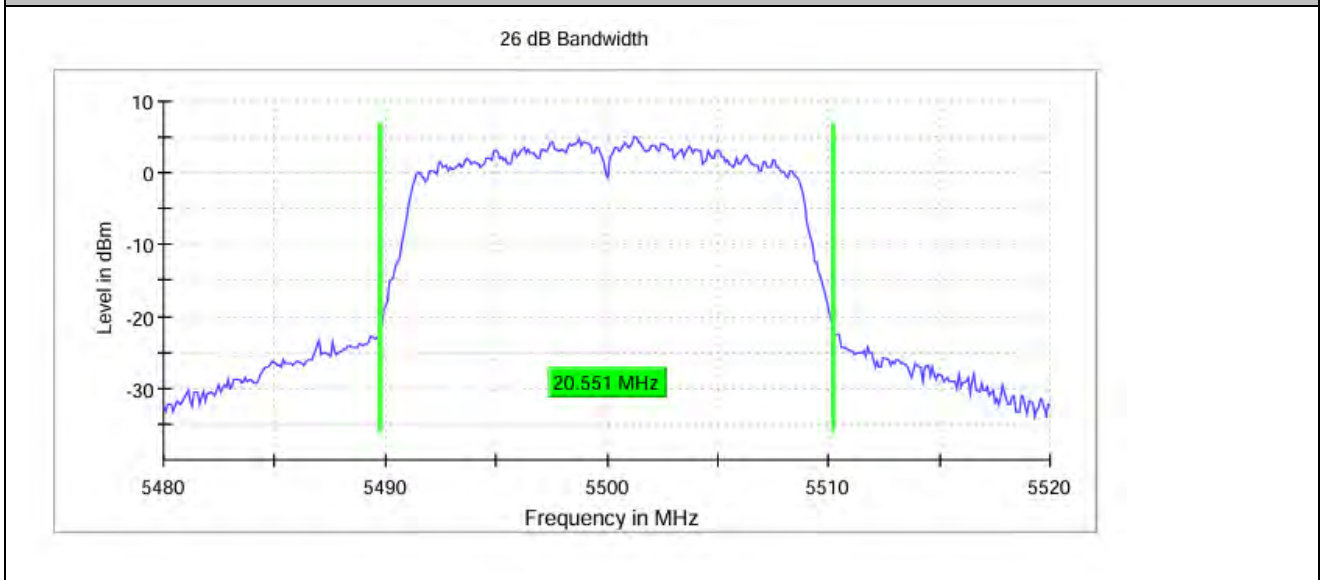

11N20_Ant0_5580

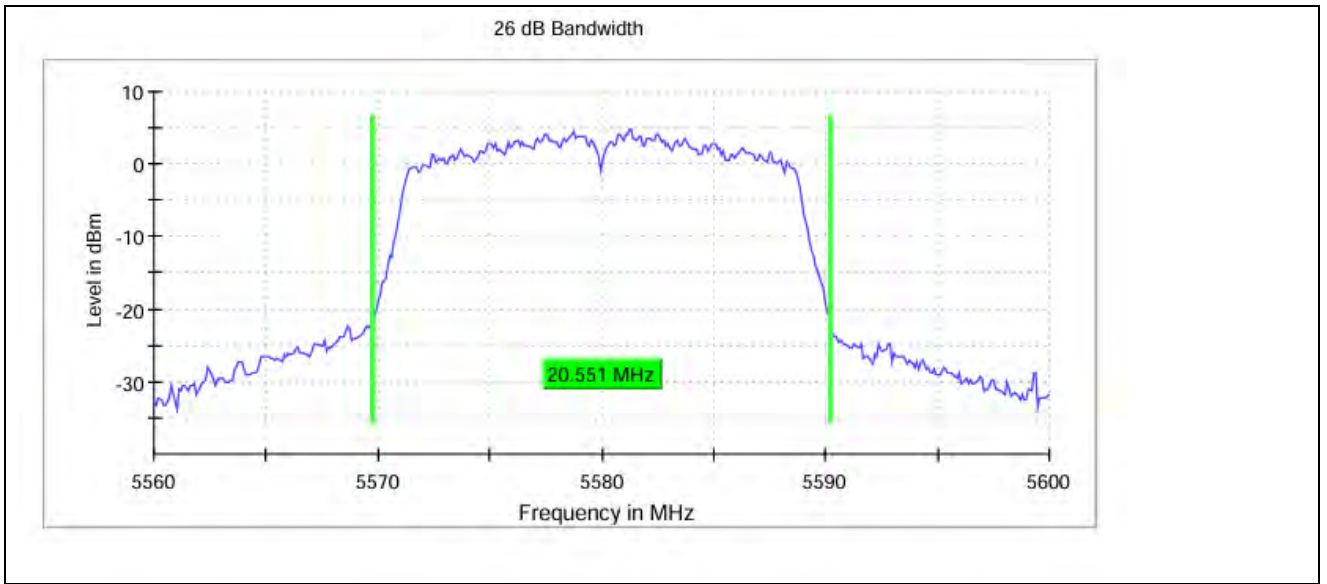

11N20_Ant0_5700

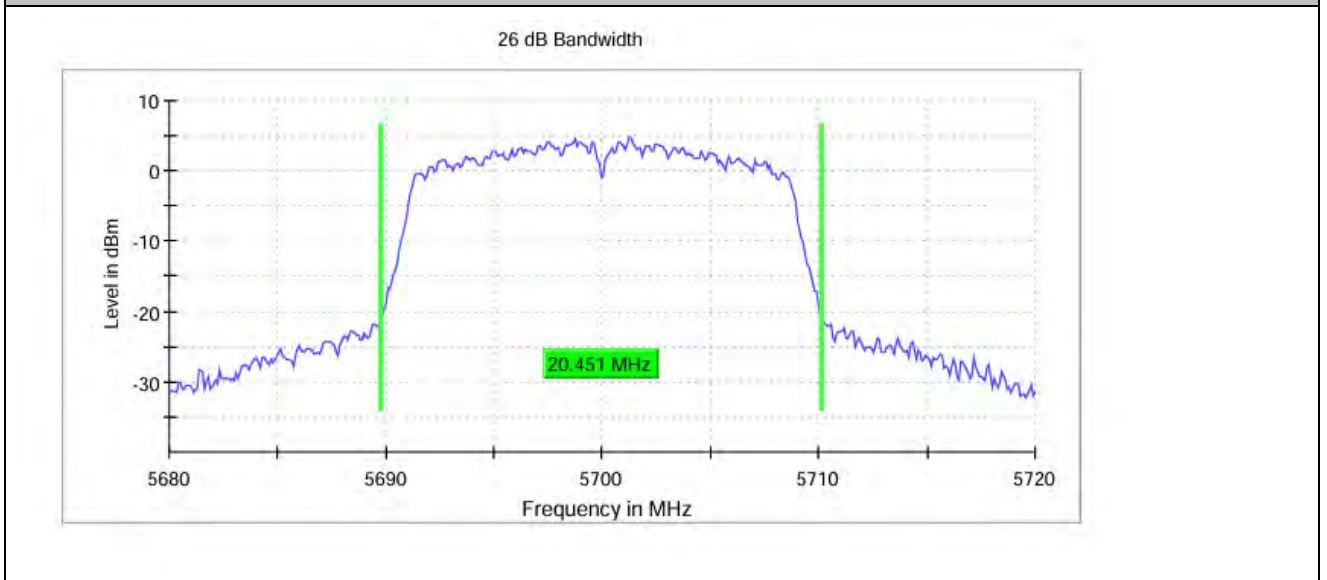

11N20_Ant0_5720

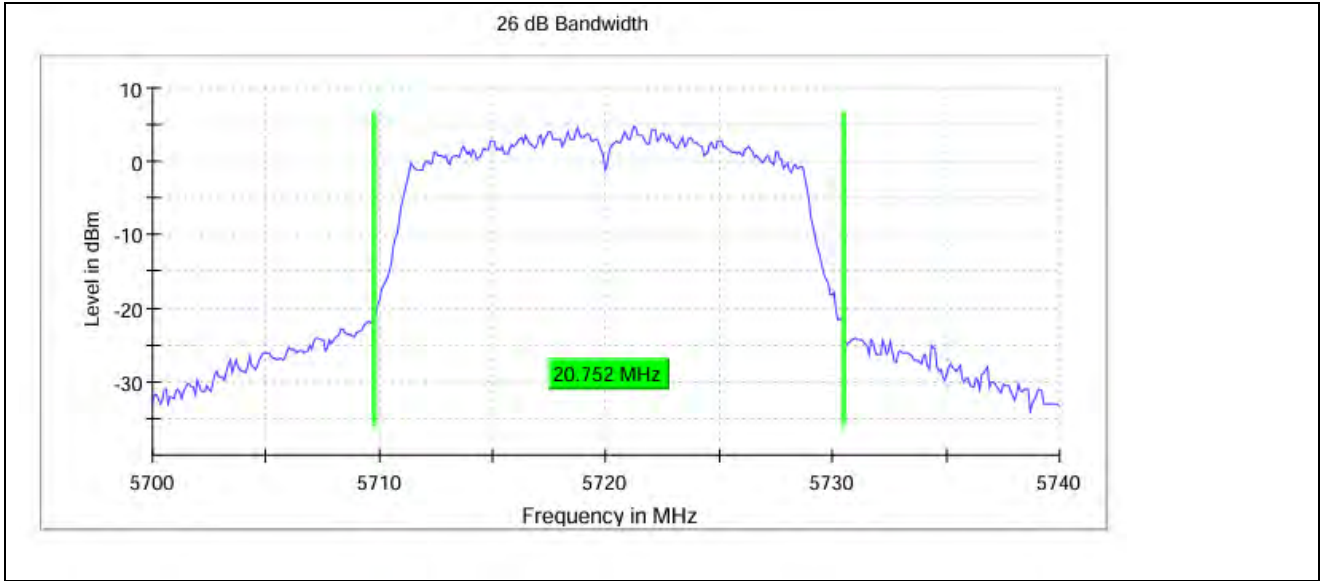

11N20_Ant0_5745

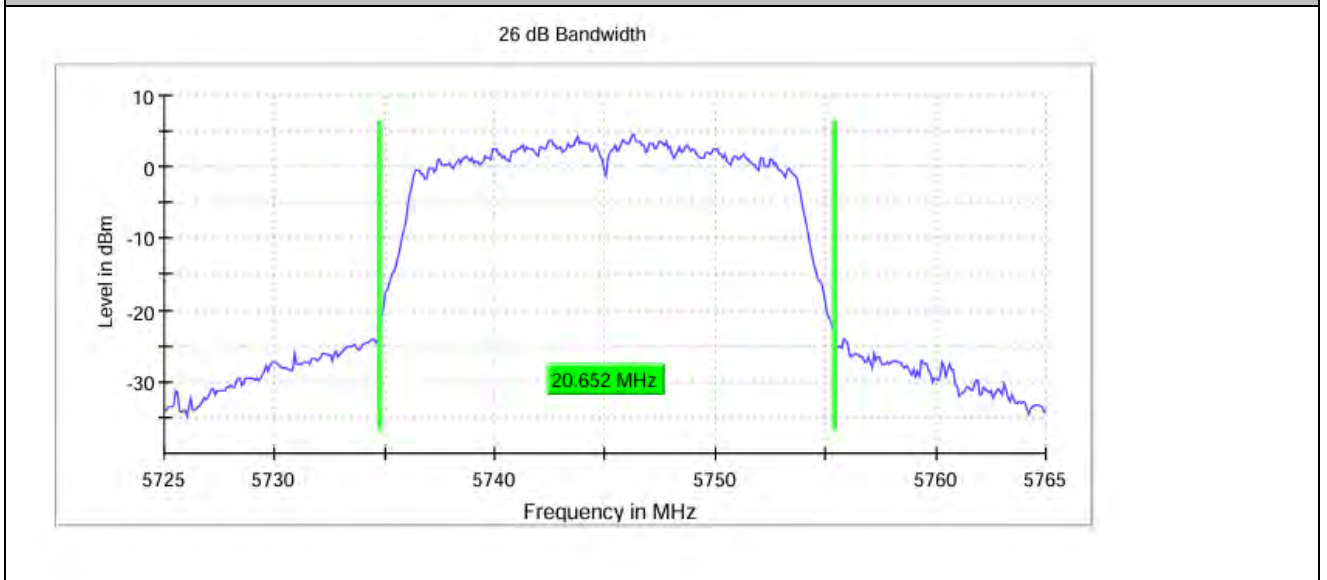

11N20_Ant0_5785



BUREAU
VERITAS

Test Report No.: W7L-240618W002RF03

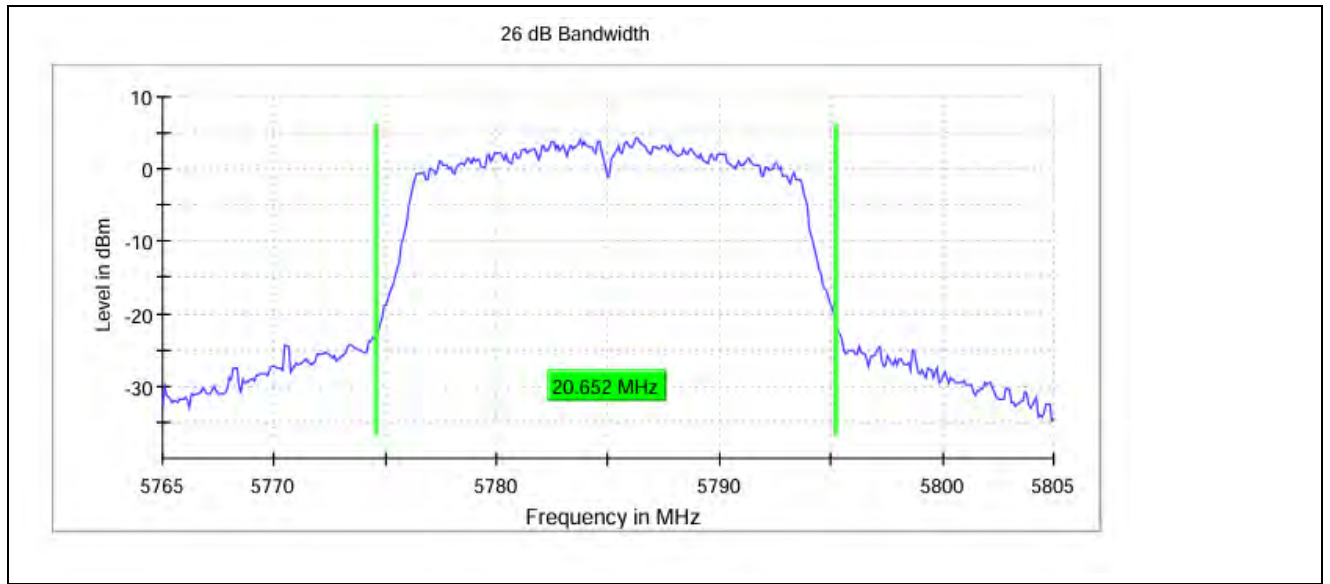

11N20_Ant0_5825



11N40_Ant0_5190

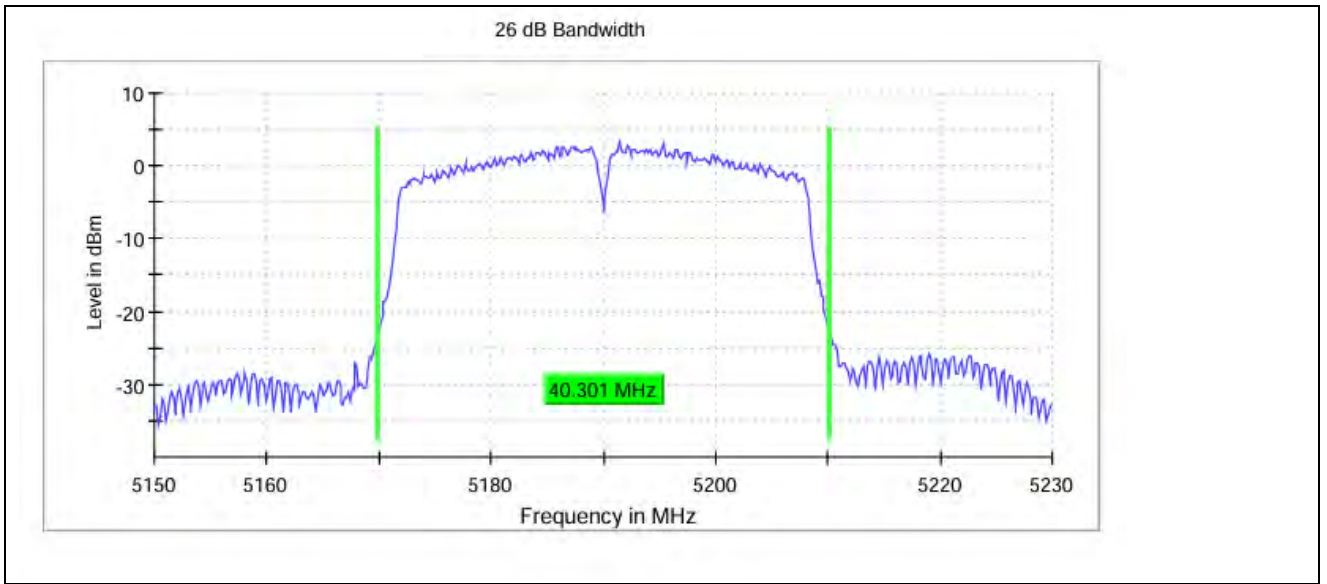

11N40_Ant0_5230

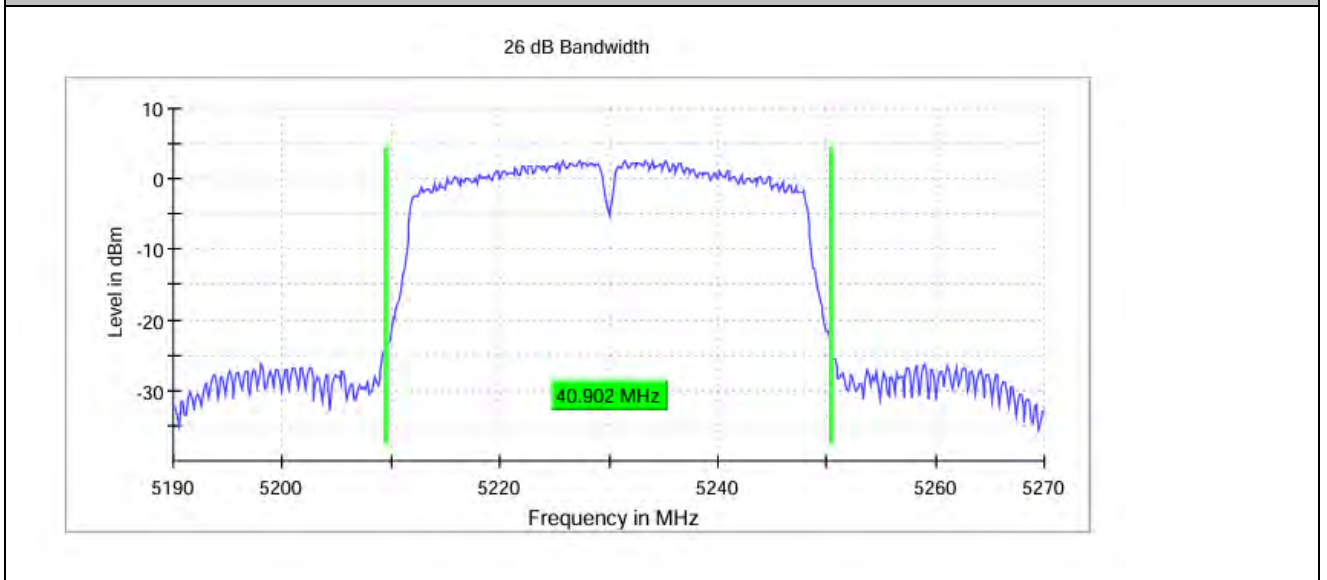

11N40_Ant0_5270

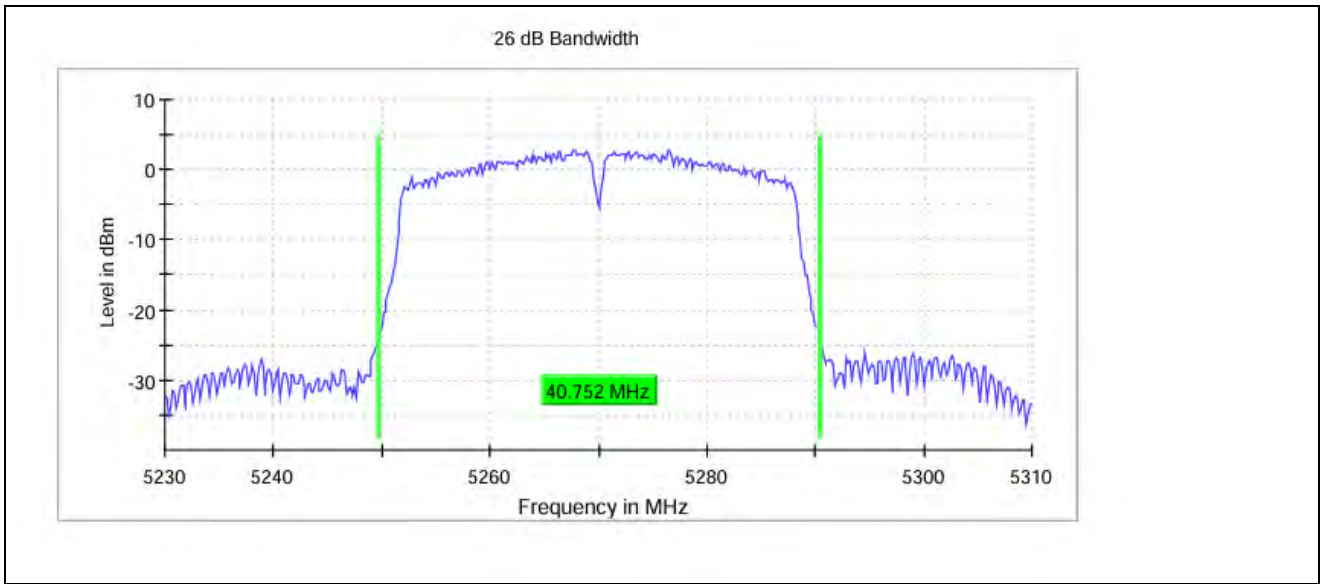

11N40_Ant0_5310

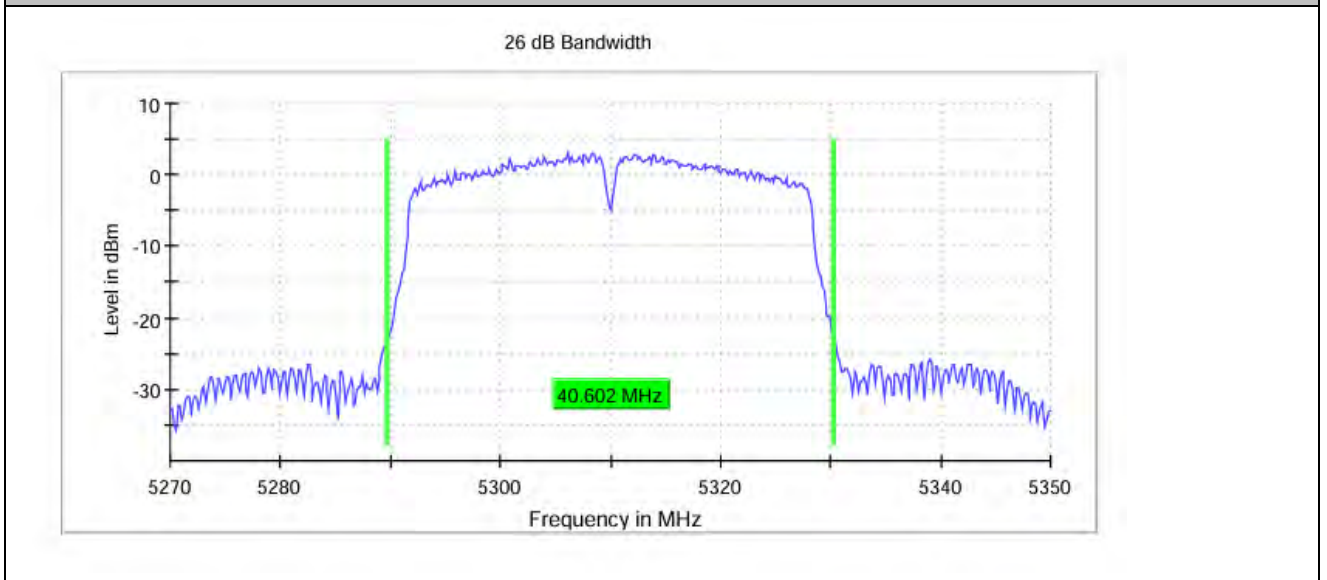

11N40_Ant0_5510



BUREAU
VERITAS

Test Report No.: W7L-240618W002RF03

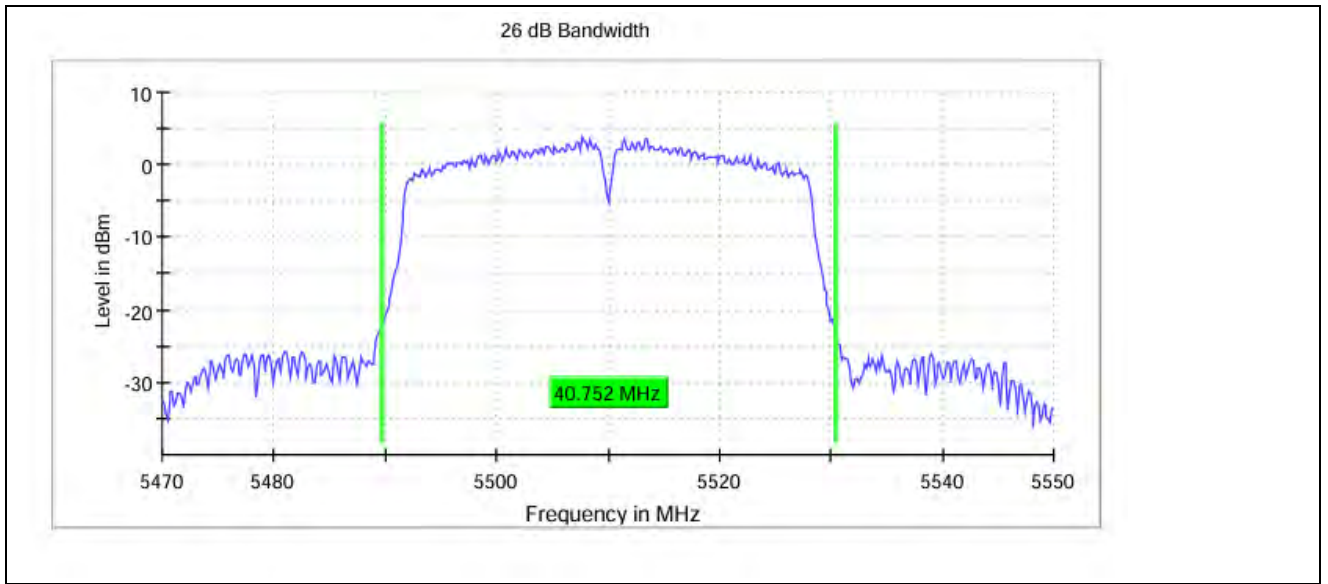

11N40_Ant0_5550

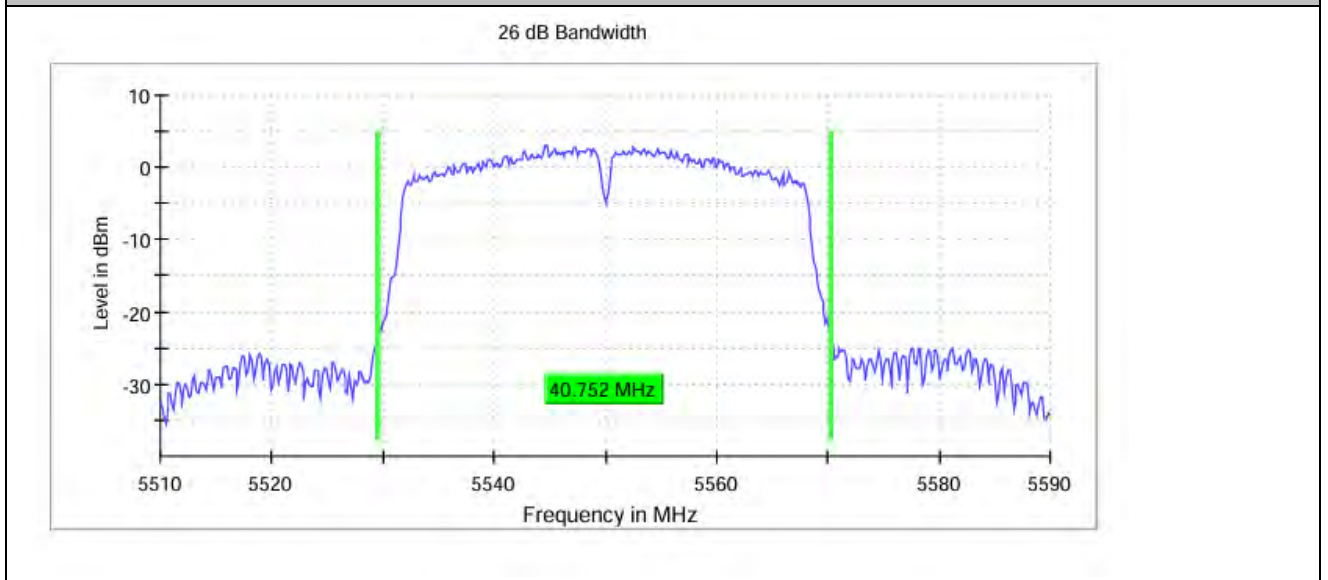

11N40_Ant0_5670

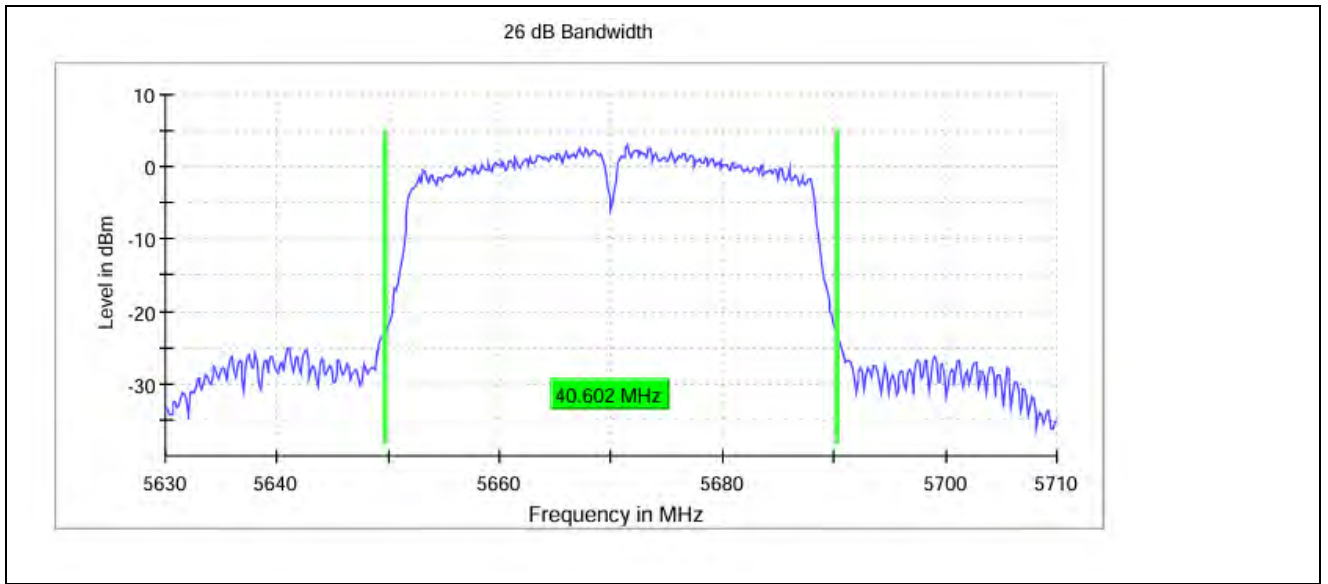

11N40_Ant0_5710

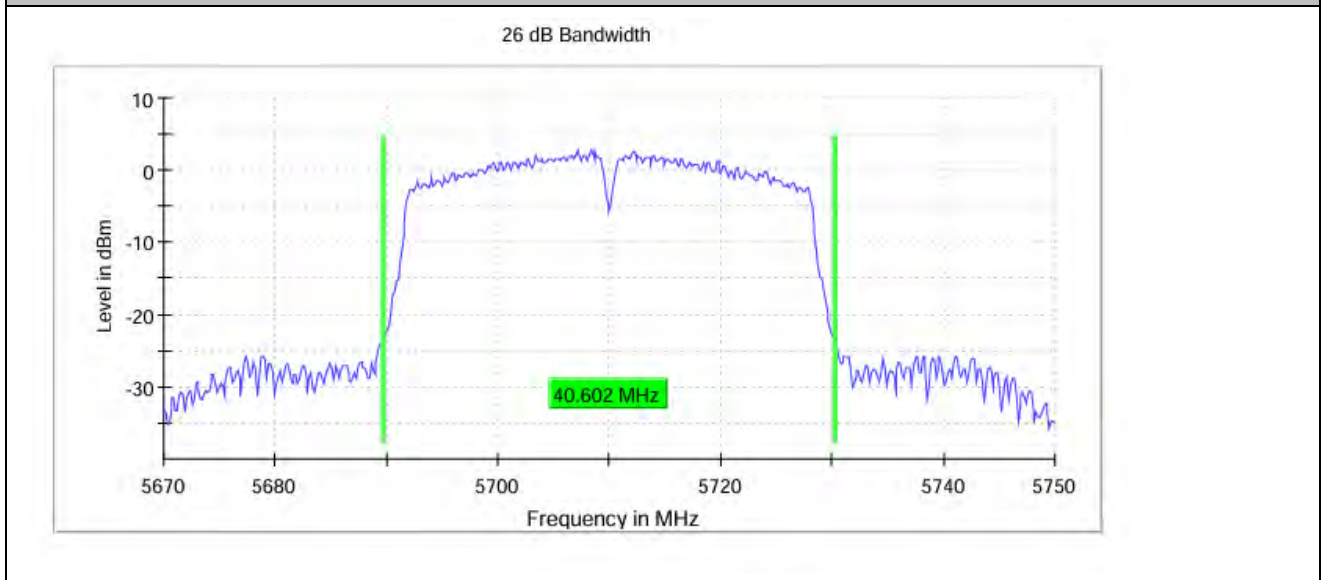

11N40_Ant0_5755

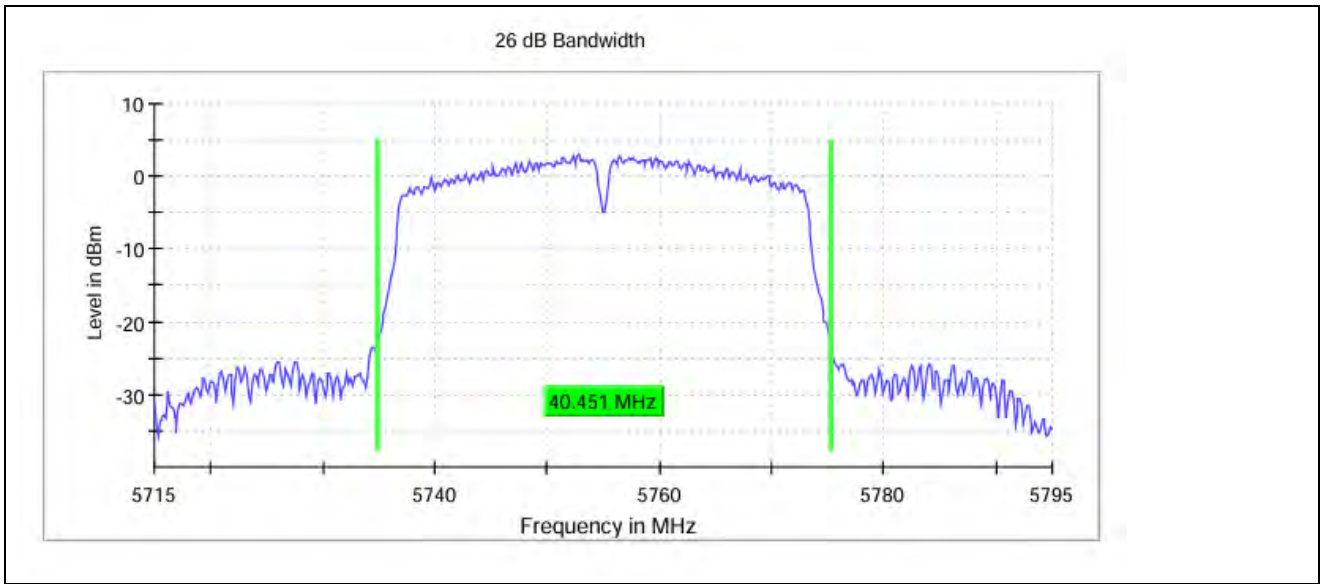

11N40_Ant0_5795

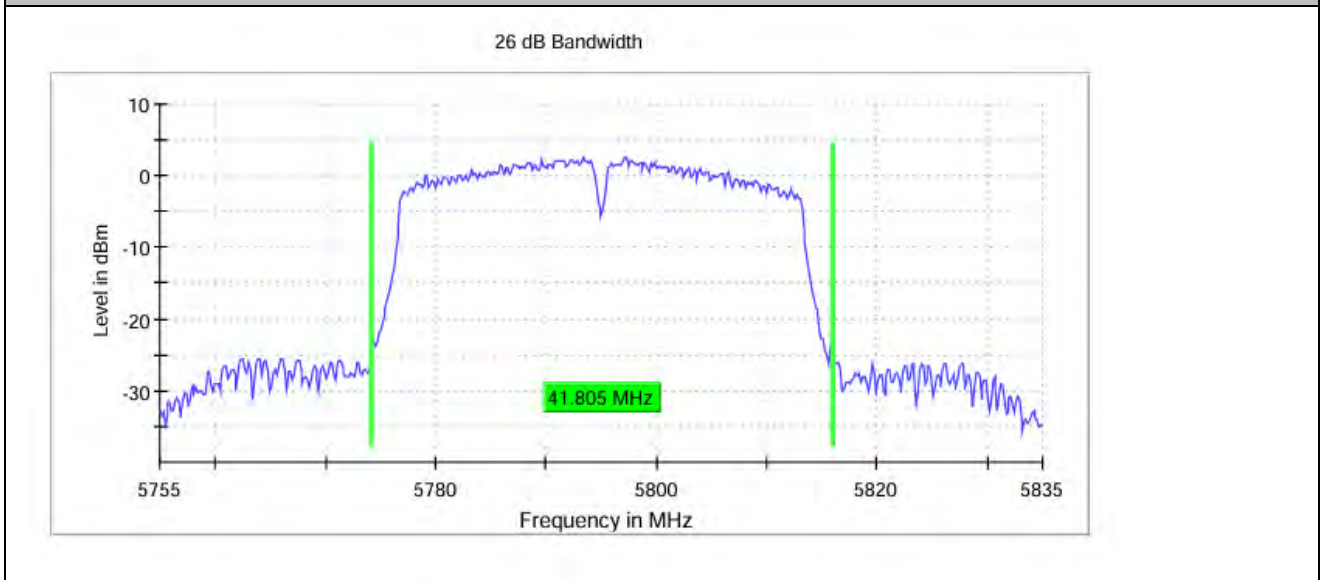

11AC80_Ant0_5210



BUREAU
VERITAS

Test Report No.: W7L-240618W002RF03

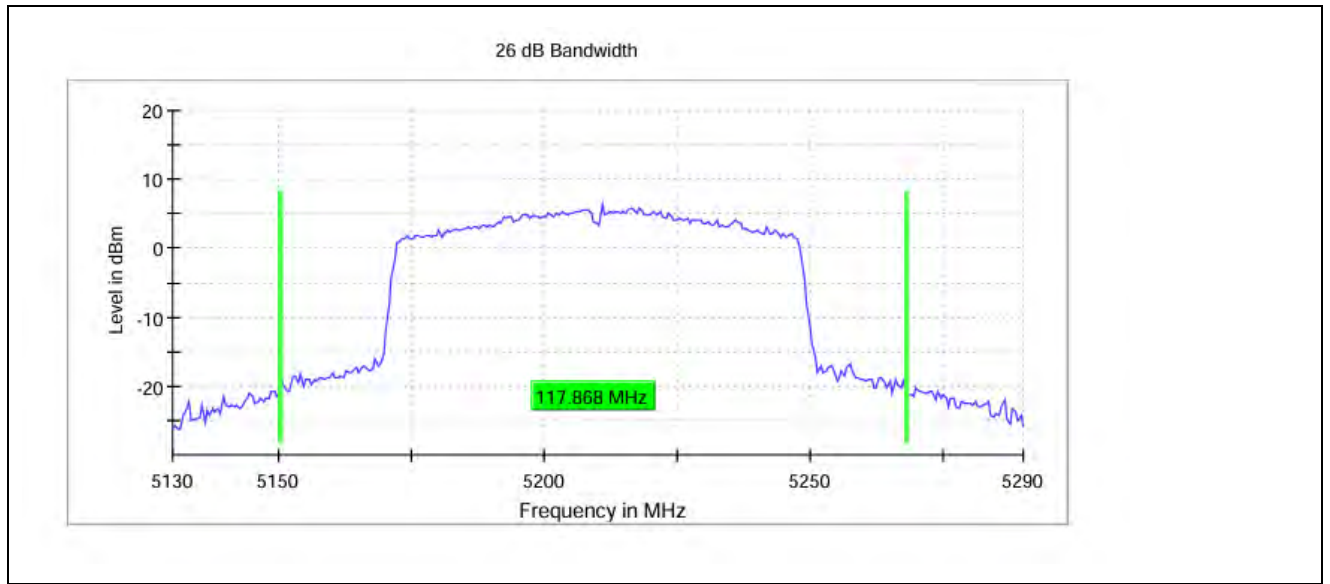

11AC80_Ant0_5290

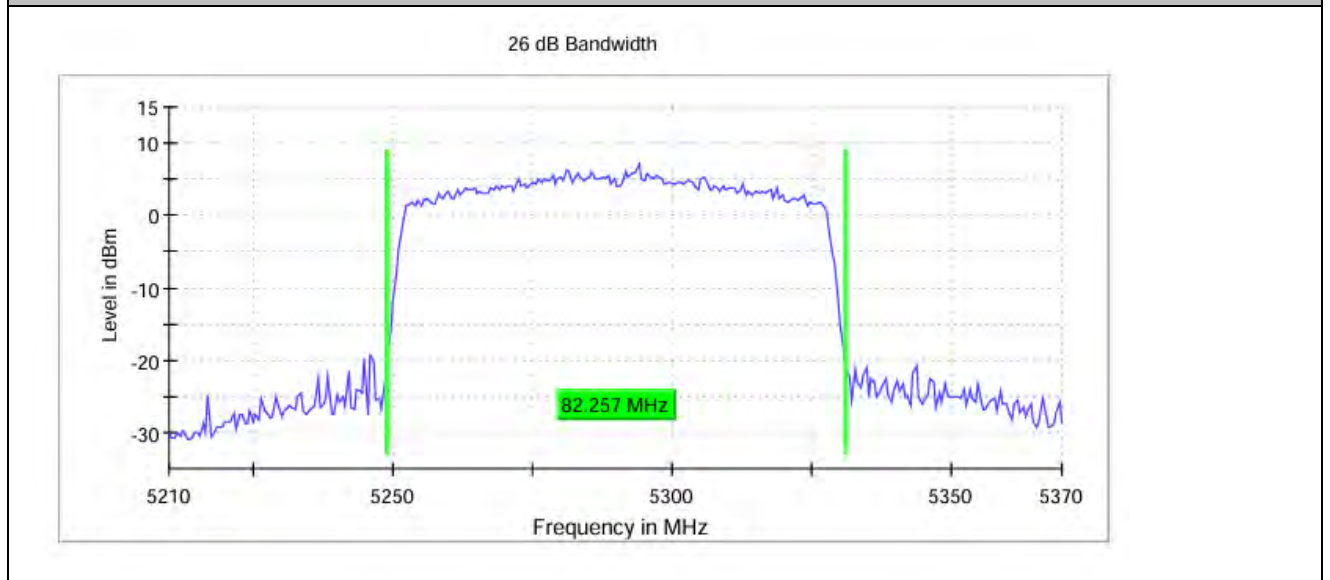

11AC80_Ant0_5530



BUREAU
VERITAS

Test Report No.: W7L-240618W002RF03

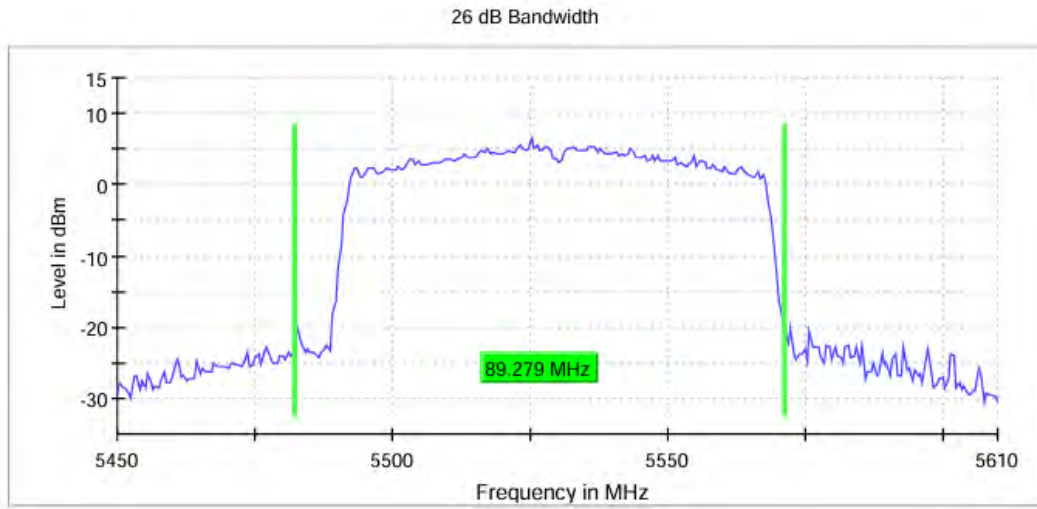

11AC80_Ant0_5610

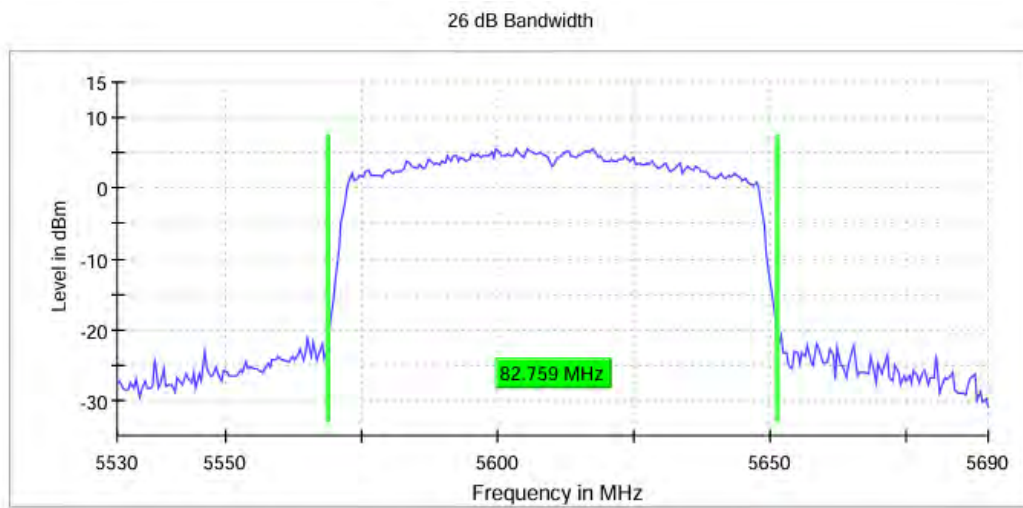

11AC80_Ant0_5690



11AC80_Ant0_5775



20M

RBW200 KHz

VBW 1 MHz

40M

RBW500 KHz

VBW 2 MHz

80M

RBW 1.000 MHz

VBW 3.000 MHz



OCCUPIED CHANNEL BANDWIDTH

TEST RESULT

TestMode	Antenna	Frequency [MHz]	OCB [MHz]	FL[MHz]	FH[MHz]	Limit[MHz]	Verdict
11A	Ant0	5180	16.742	5171.629	5188.371	---	---
	Ant0	5200	16.742	5191.629	5208.371	---	---
	Ant0	5240	16.541	5231.729	5248.270	---	---
	Ant0	5260	16.541	5251.729	5268.270	---	---
	Ant0	5300	16.642	5291.629	5308.271	---	---
	Ant0	5320	16.541	5311.729	5328.270	---	---
	Ant0	5500	16.541	5491.729	5508.270	---	---
	Ant0	5580	16.541	5571.729	5588.270	---	---
	Ant0	5700	16.541	5691.729	5708.270	---	---
	Ant0	5720	16.541	5711.729	5728.270	---	---
	Ant0	5745	16.541	5736.729	5753.270	---	---
	Ant0	5785	16.541	5776.729	5793.270	---	---
11N20	Ant0	5180	17.744	5171.128	5188.872	---	---
	Ant0	5200	17.744	5191.128	5208.872	---	---
	Ant0	5240	17.744	5231.128	5248.872	---	---
	Ant0	5260	17.744	5251.128	5268.872	---	---
	Ant0	5300	17.744	5291.128	5308.872	---	---
	Ant0	5320	17.744	5311.128	5328.872	---	---
	Ant0	5500	17.744	5491.128	5508.872	---	---
	Ant0	5580	17.744	5571.128	5588.872	---	---
	Ant0	5700	17.744	5691.128	5708.872	---	---
	Ant0	5720	17.744	5711.128	5728.872	---	---
	Ant0	5745	17.744	5736.128	5753.872	---	---
	Ant0	5785	17.744	5776.128	5793.872	---	---
11N40	Ant0	5190	36.364	5171.818	5208.182	---	---
	Ant0	5230	36.364	5211.818	5248.182	---	---
	Ant0	5270	36.364	5251.818	5288.182	---	---



	Ant0	5310	36.364	5291.818	5328.182	---	---
	Ant0	5510	36.364	5491.818	5528.182	---	---
	Ant0	5550	36.364	5531.818	5568.182	---	---
	Ant0	5670	36.364	5651.818	5688.182	---	---
	Ant0	5710	36.364	5691.818	5728.182	---	---
	Ant0	5755	36.364	5736.818	5773.182	---	---
	Ant0	5795	36.614	5776.567	5813.181	---	---
11AC80	Ant0	5210	76.740	5171.630	5248.370	---	---
	Ant0	5290	75.737	5252.132	5327.869	---	---
	Ant0	5530	75.737	5492.132	5567.869	---	---
	Ant0	5610	75.737	5572.132	5647.869	---	---
	Ant0	5690	75.737	5652.132	5727.869	---	---
	Ant0	5775	75.737	5737.131	5812.868	---	---



TEST GRAPHS

11A_Ant0_5180

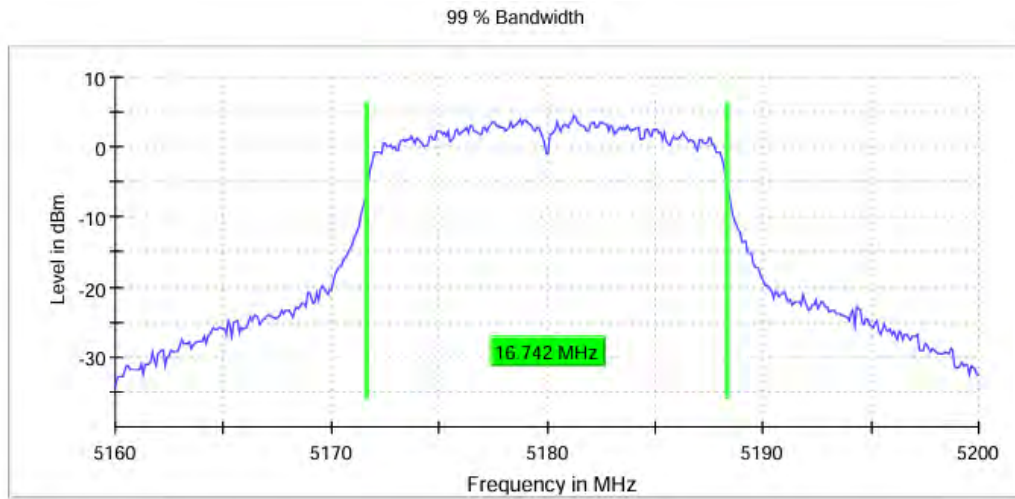

11A_Ant0_5200

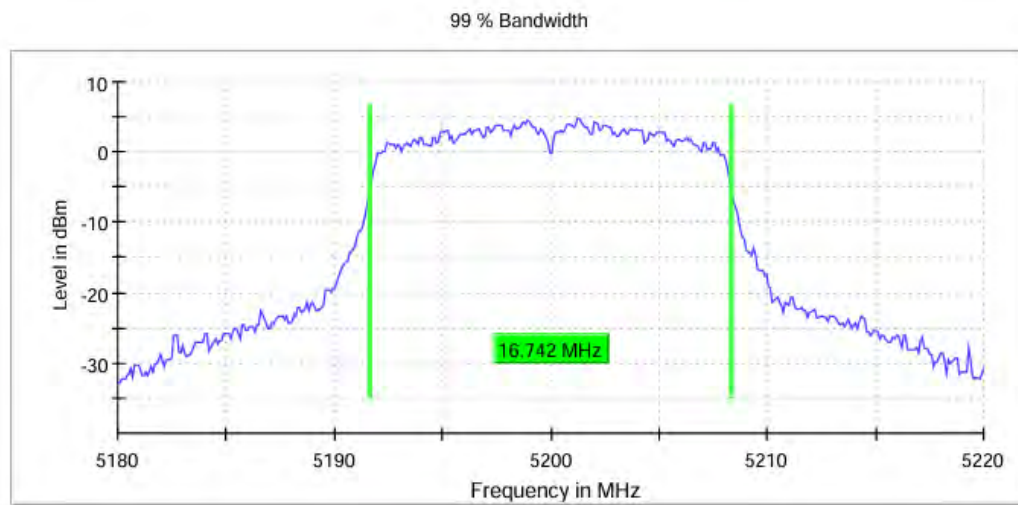

11A_Ant0_5240



BUREAU
VERITAS

Test Report No.: W7L-240618W002RF03

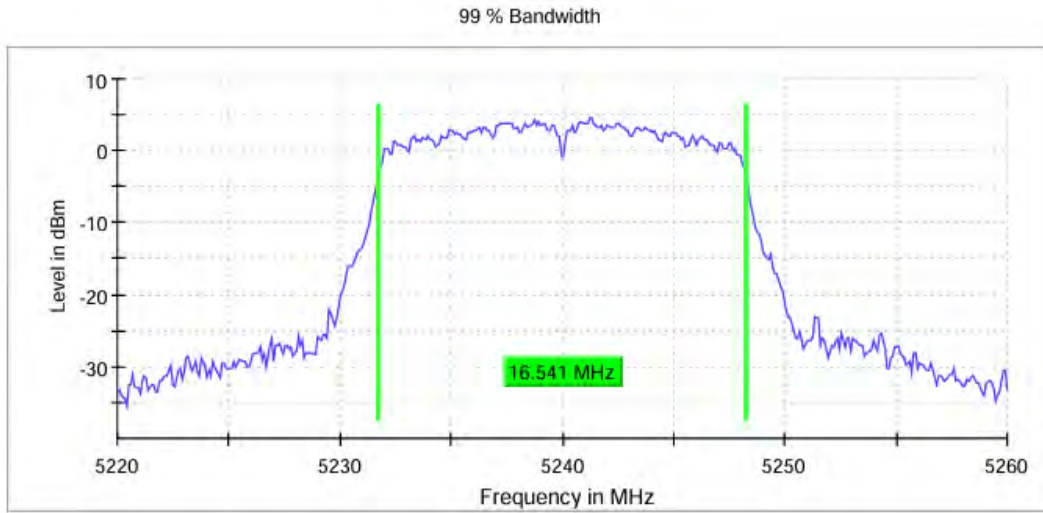

11A_Ant0_5260

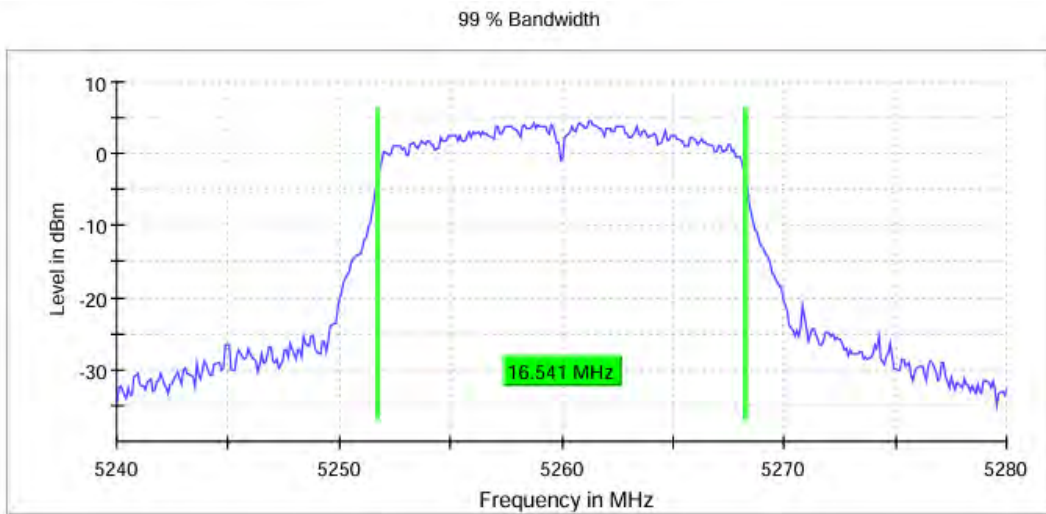

11A_Ant0_5300



BUREAU
VERITAS

Test Report No.: W7L-240618W002RF03

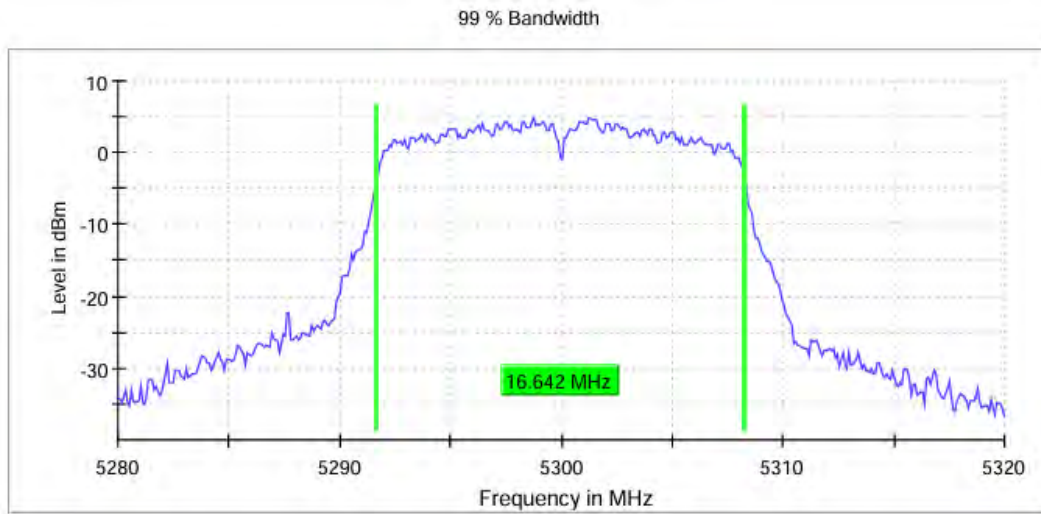

11A_Ant0_5320

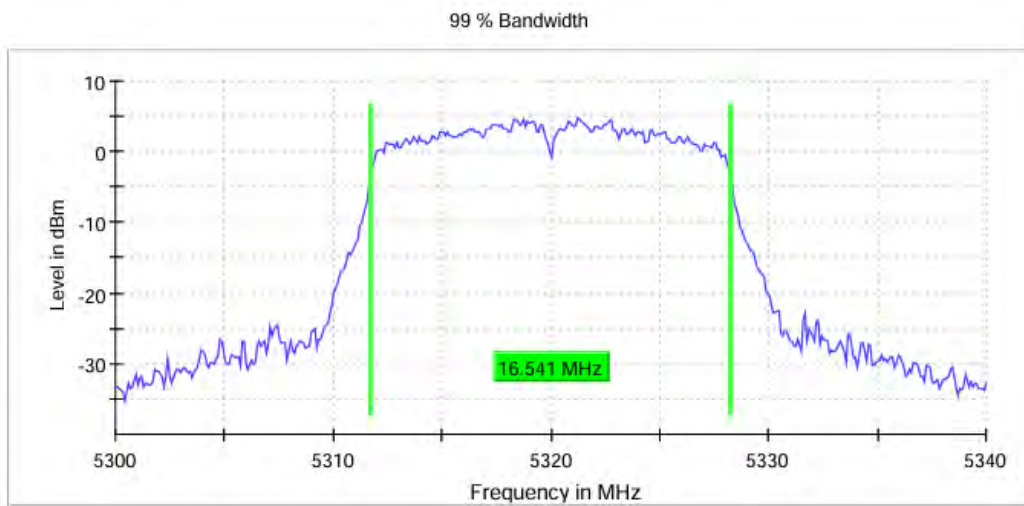

11A_Ant0_5500



BUREAU
VERITAS

Test Report No.: W7L-240618W002RF03

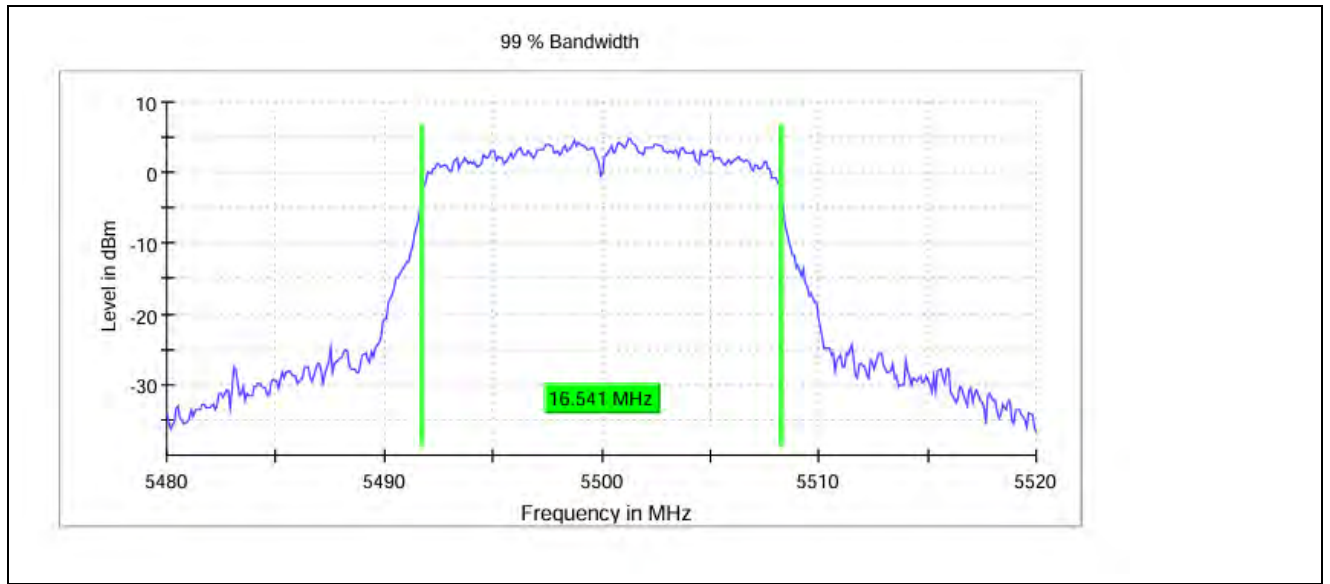

11A_Ant0_5580

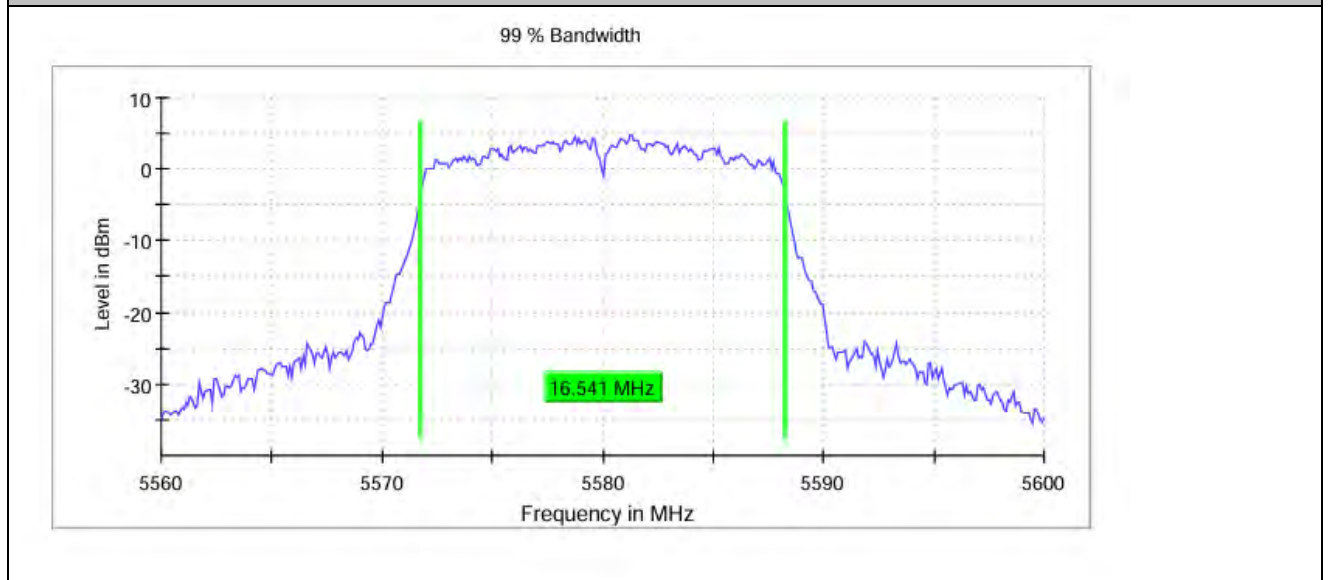

11A_Ant0_5700



BUREAU
VERITAS

Test Report No.: W7L-240618W002RF03

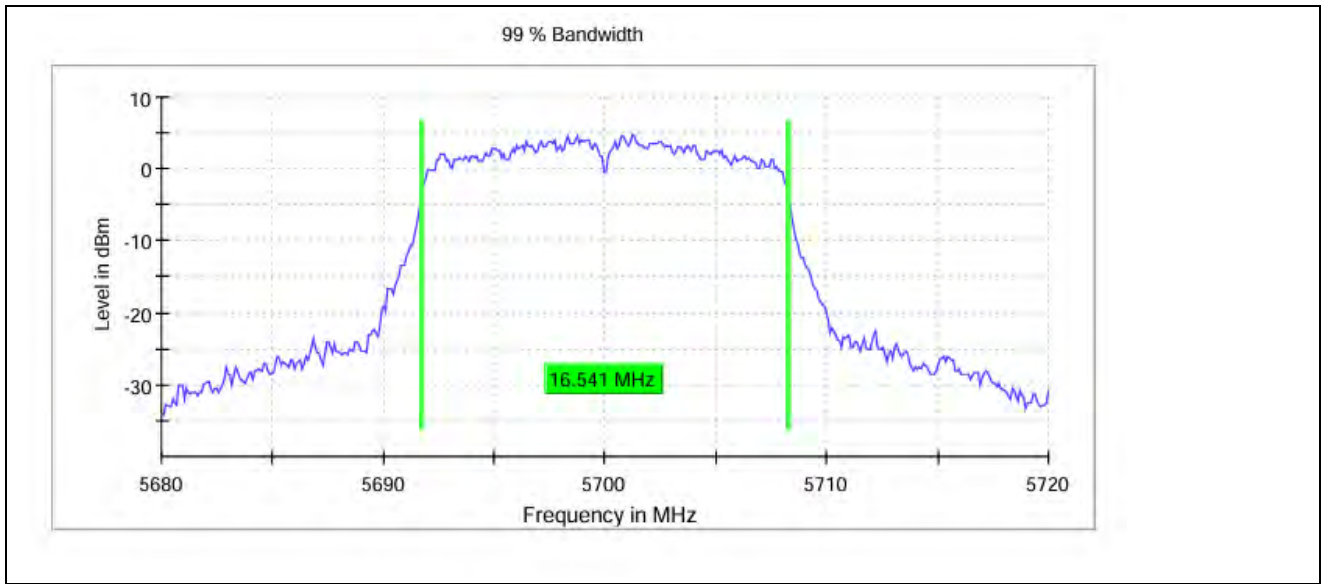

11A_Ant0_5720

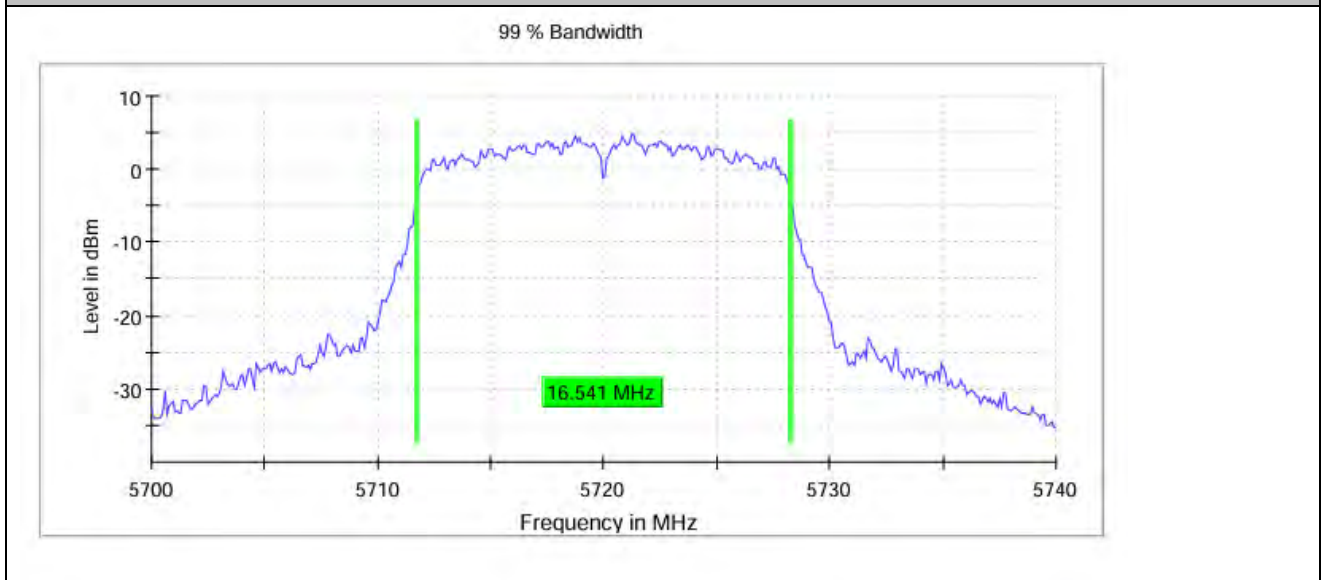

11A_Ant0_5745



BUREAU
VERITAS

Test Report No.: W7L-240618W002RF03

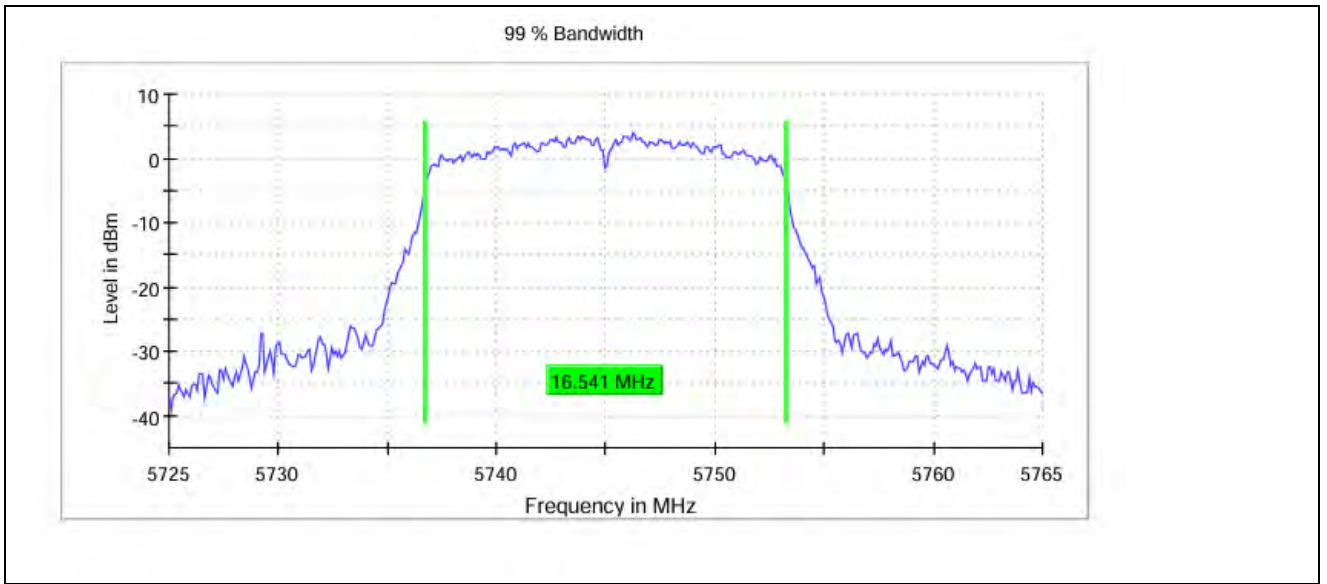

11A_Ant0_5785

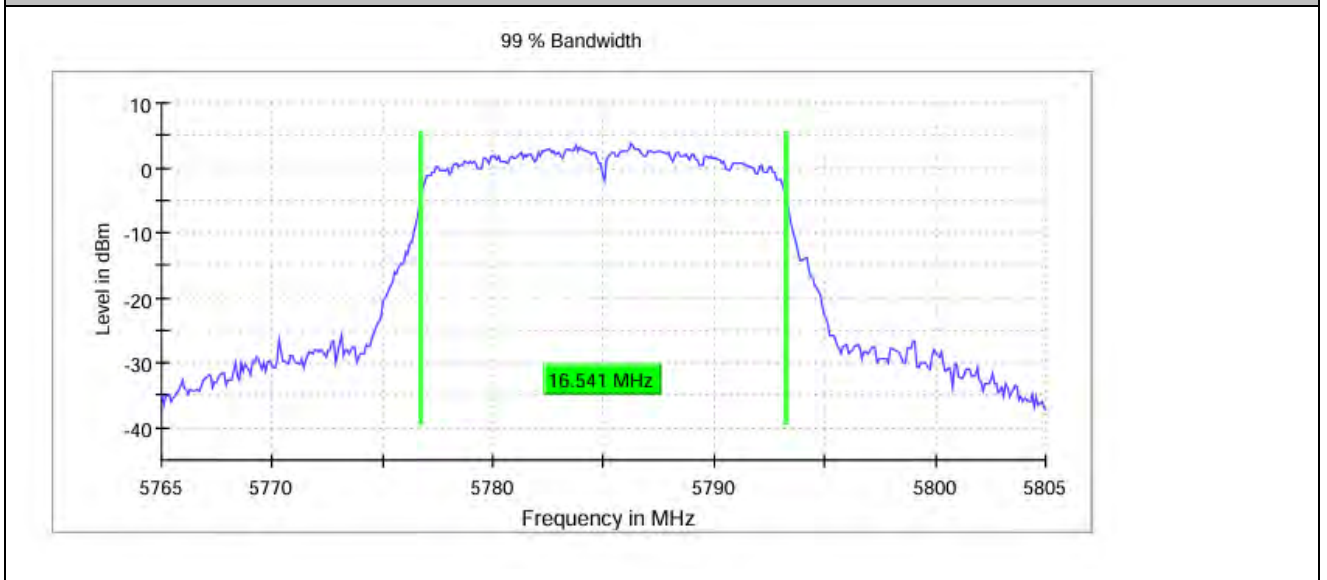

11A_Ant0_5825

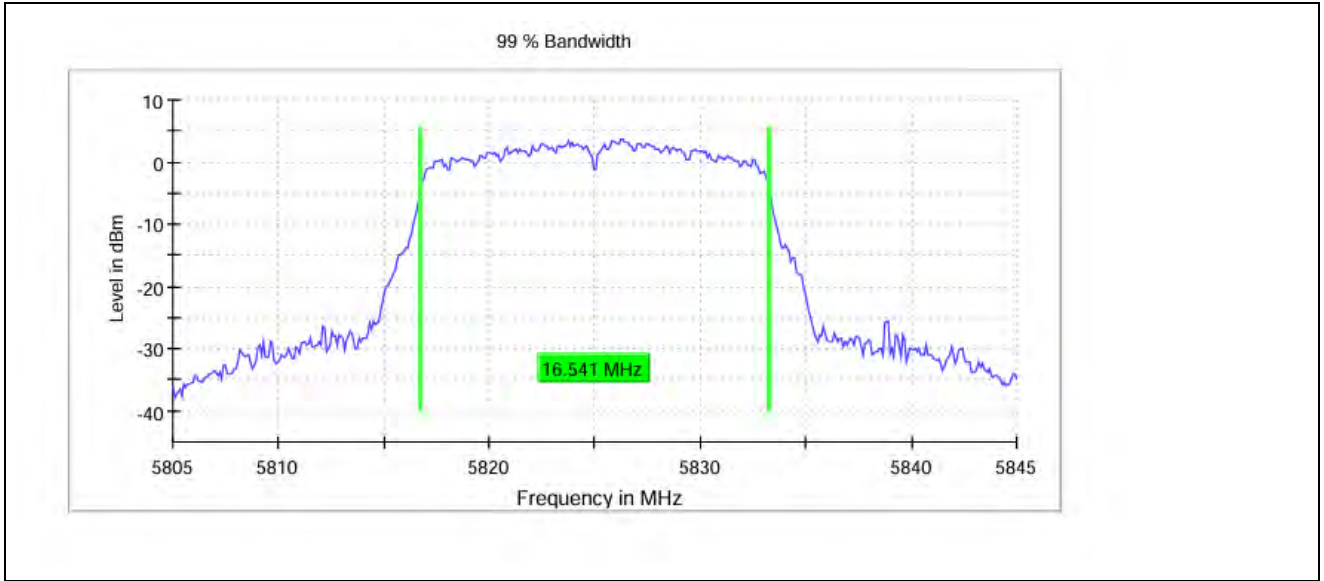

11N20_Ant0_5180

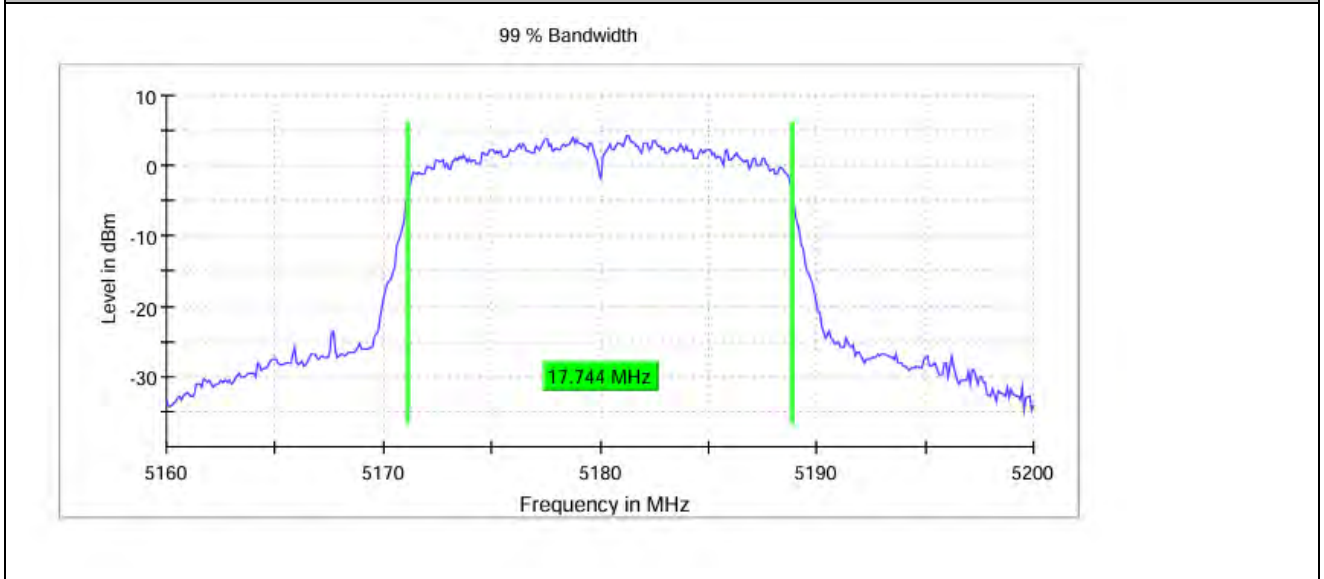

11N20_Ant0_5200



BUREAU
VERITAS

Test Report No.: W7L-240618W002RF03

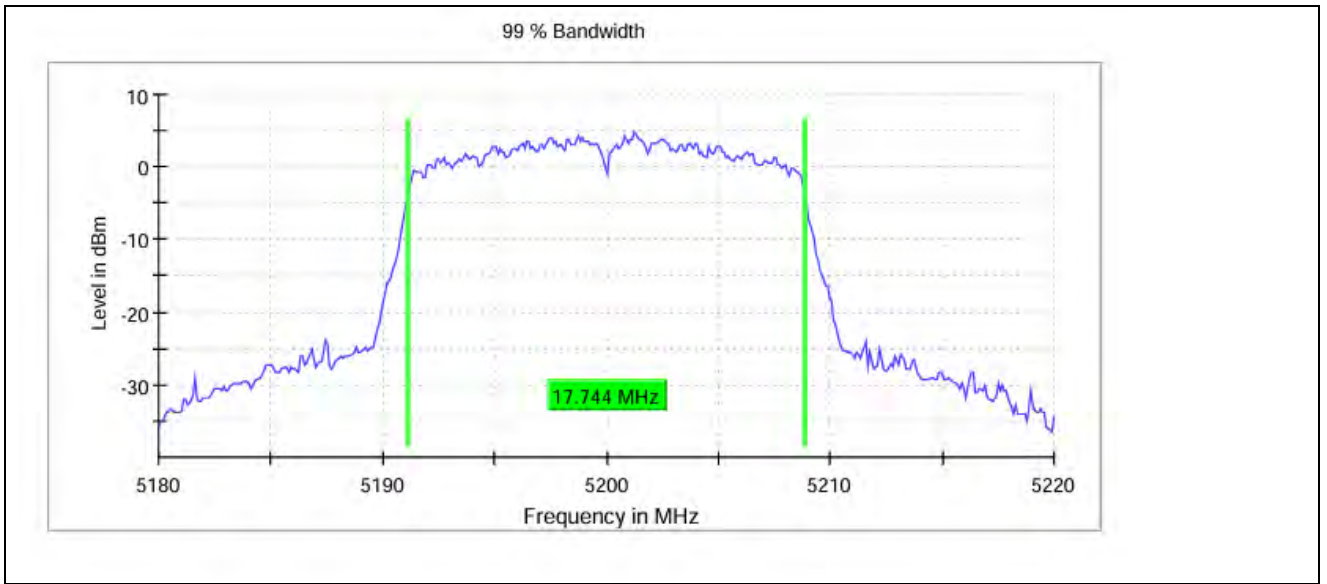

11N20_Ant0_5240

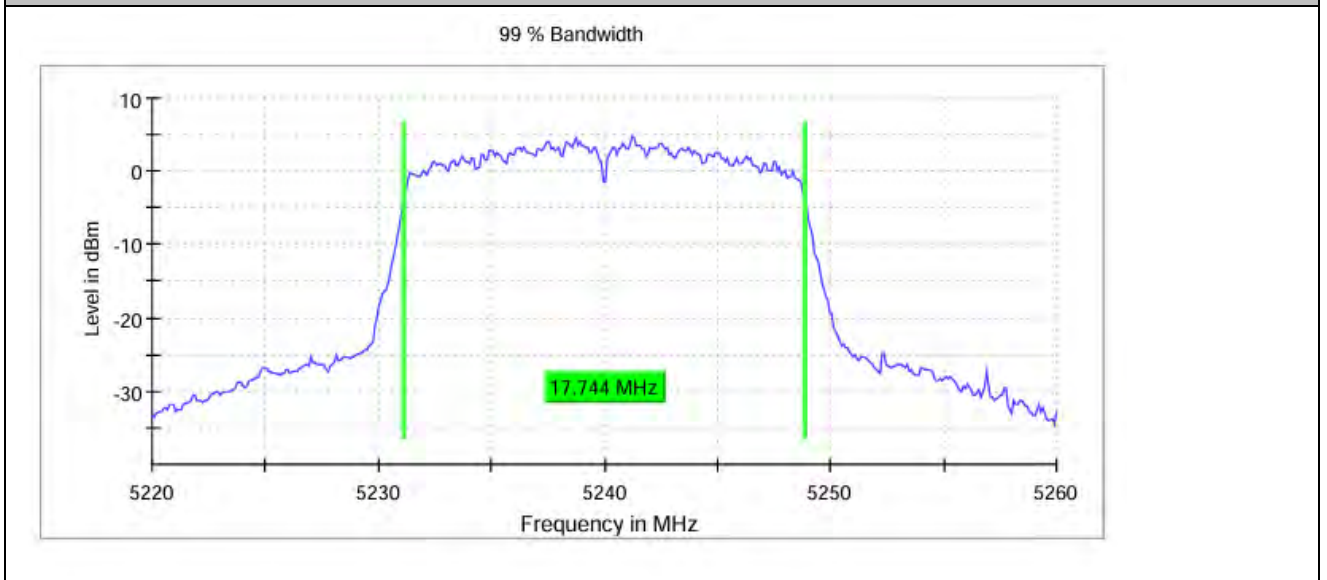

11N20_Ant0_5260



BUREAU
VERITAS

Test Report No.: W7L-240618W002RF03

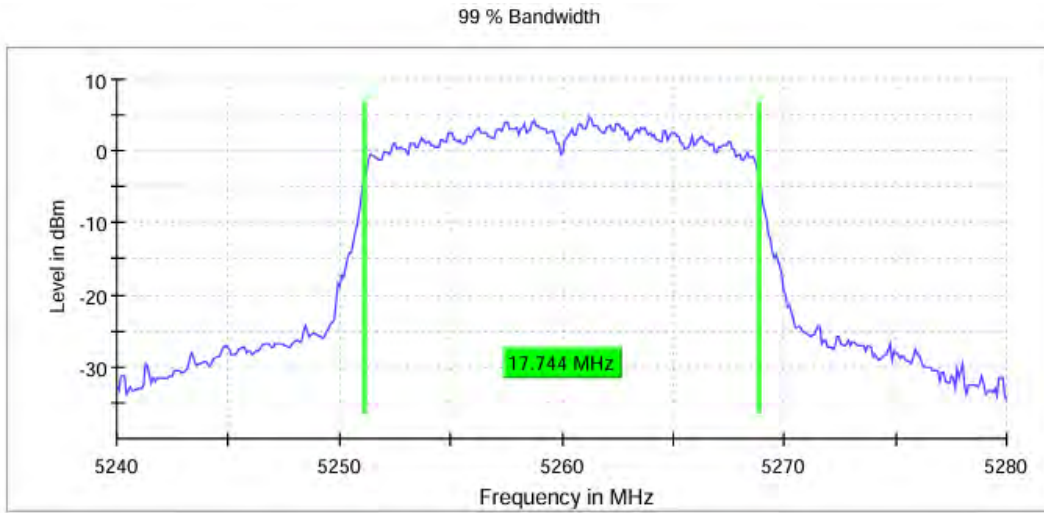

11N20_Ant0_5300

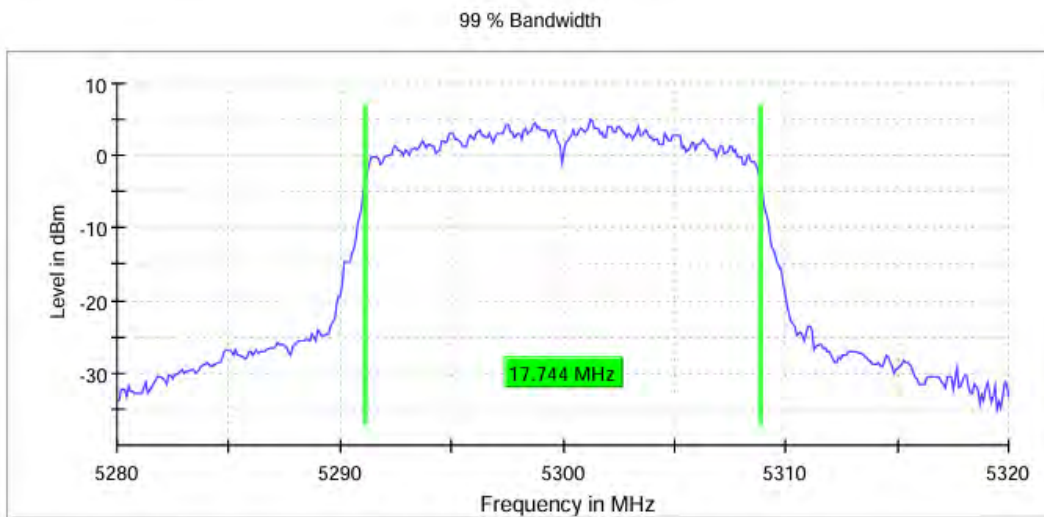

11N20_Ant0_5320

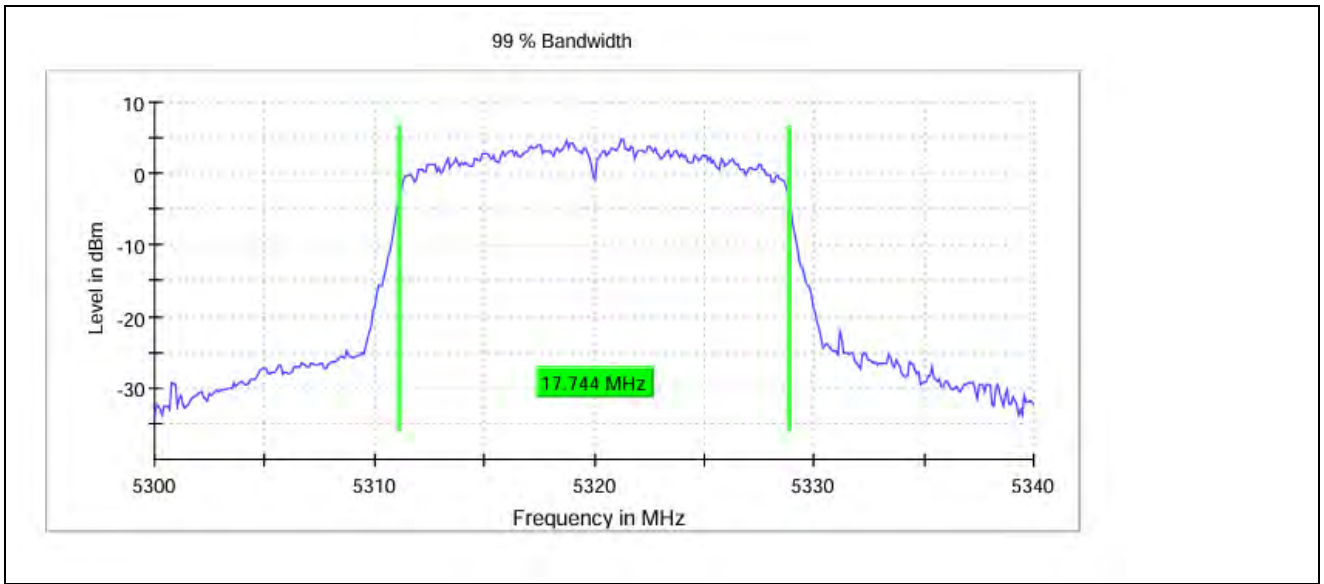

11N20_Ant0_5500

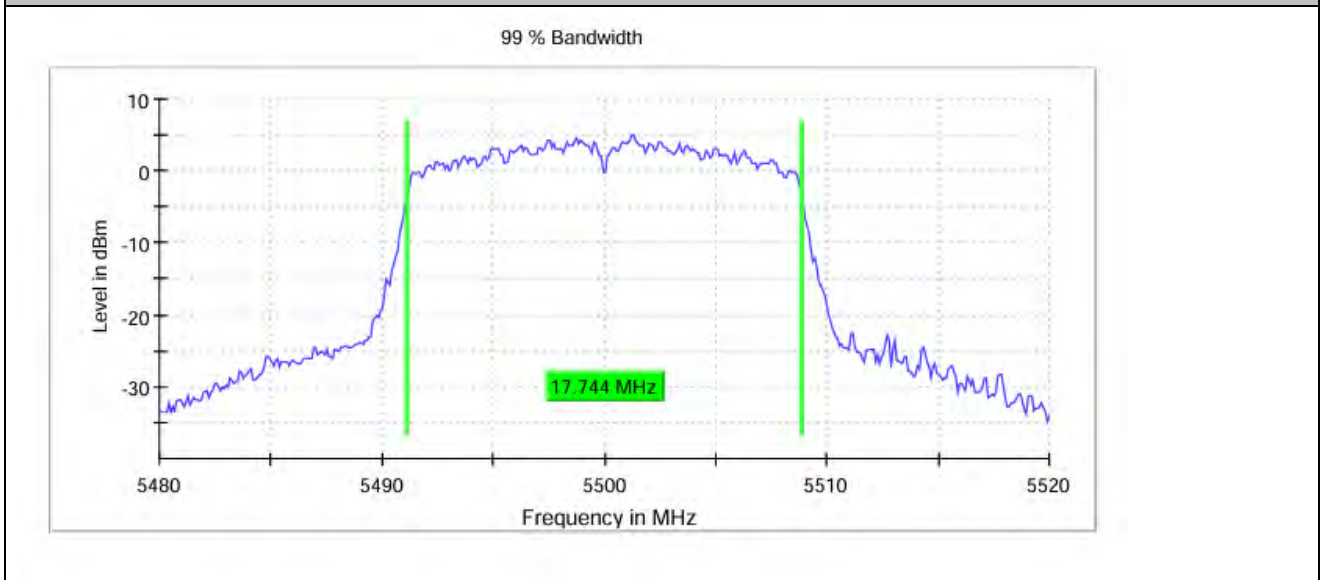

11N20_Ant0_5580



BUREAU
VERITAS

Test Report No.: W7L-240618W002RF03

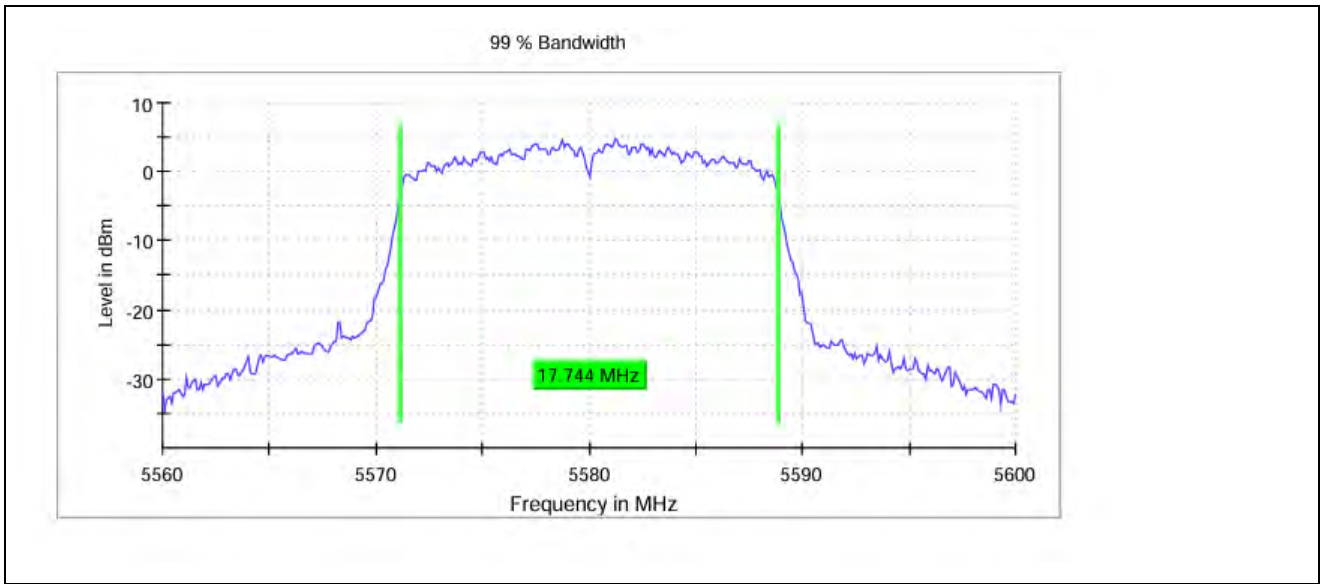

11N20_Ant0_5700

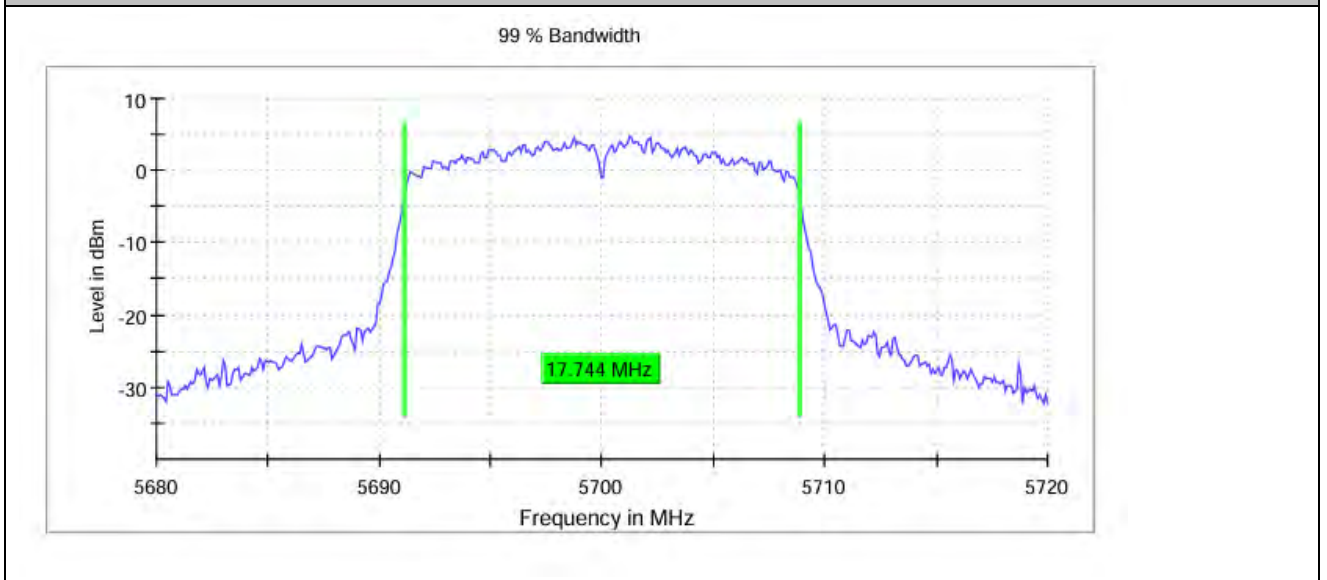

11N20_Ant0_5720



BUREAU
VERITAS

Test Report No.: W7L-240618W002RF03

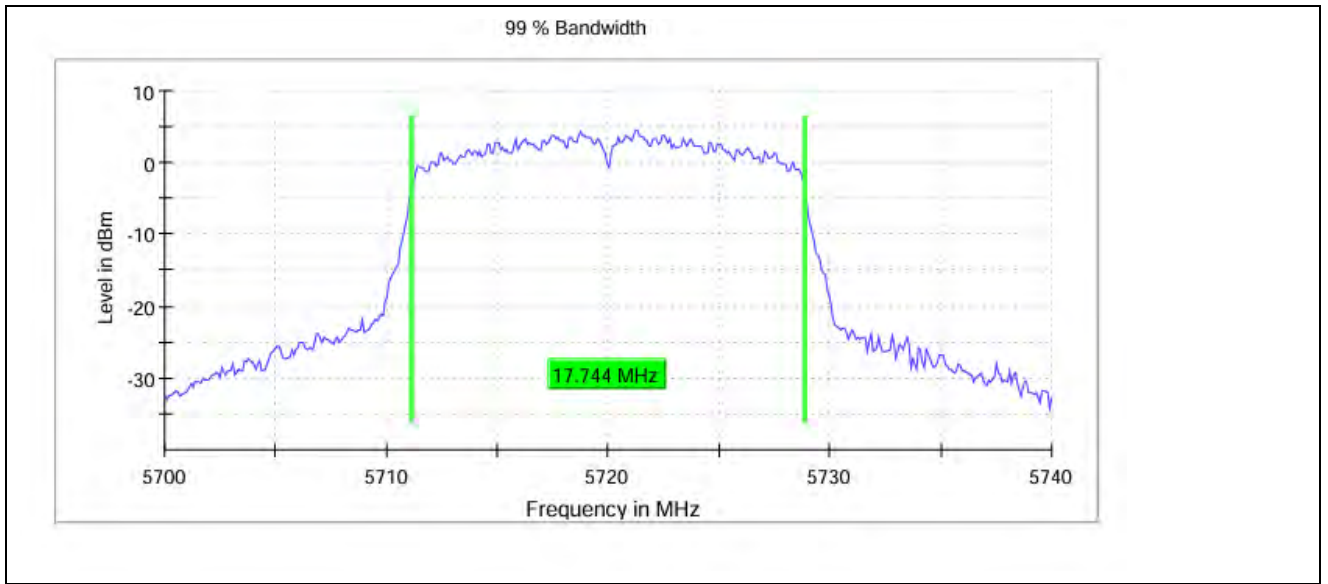

11N20_Ant0_5745

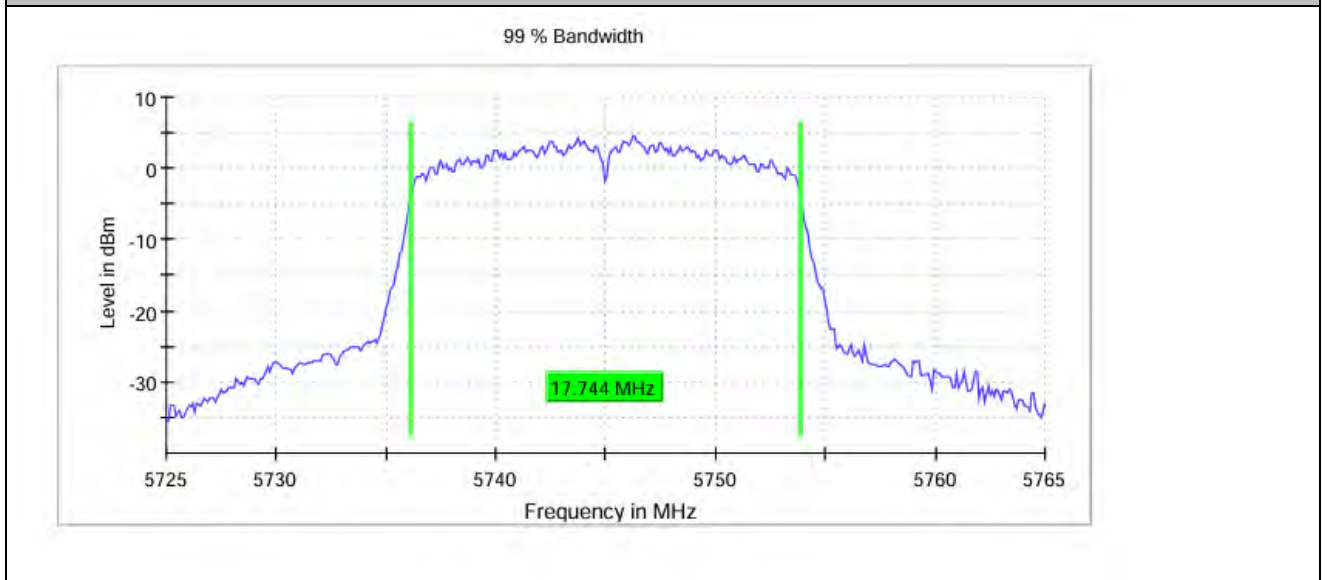

11N20_Ant0_5785

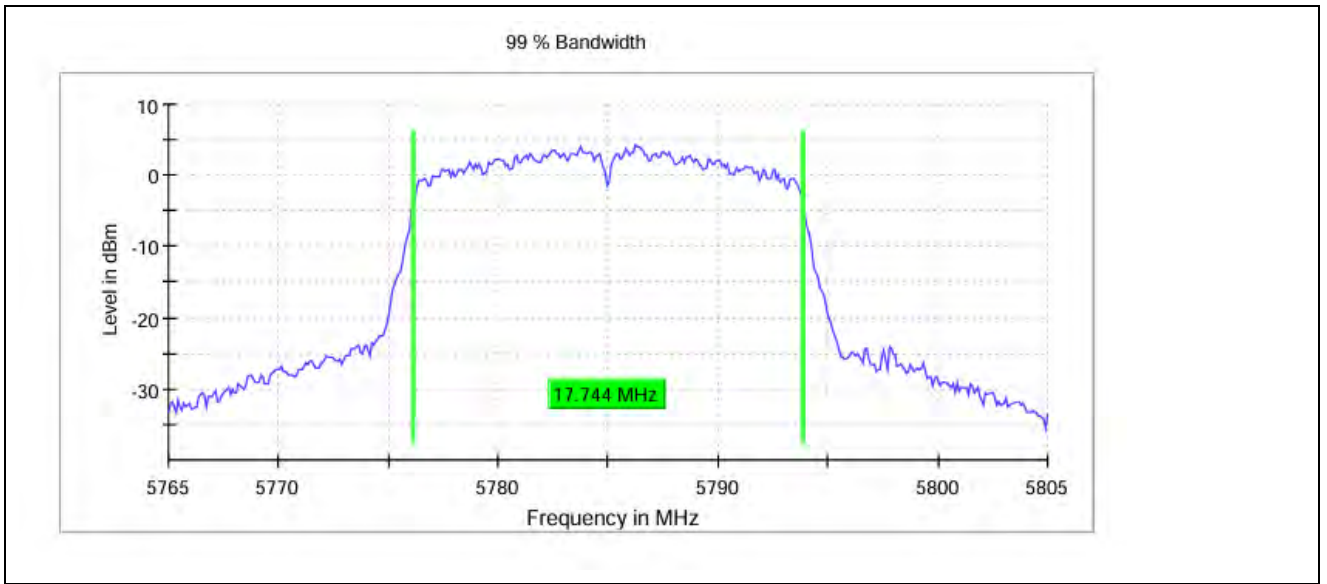

11N20_Ant0_5825

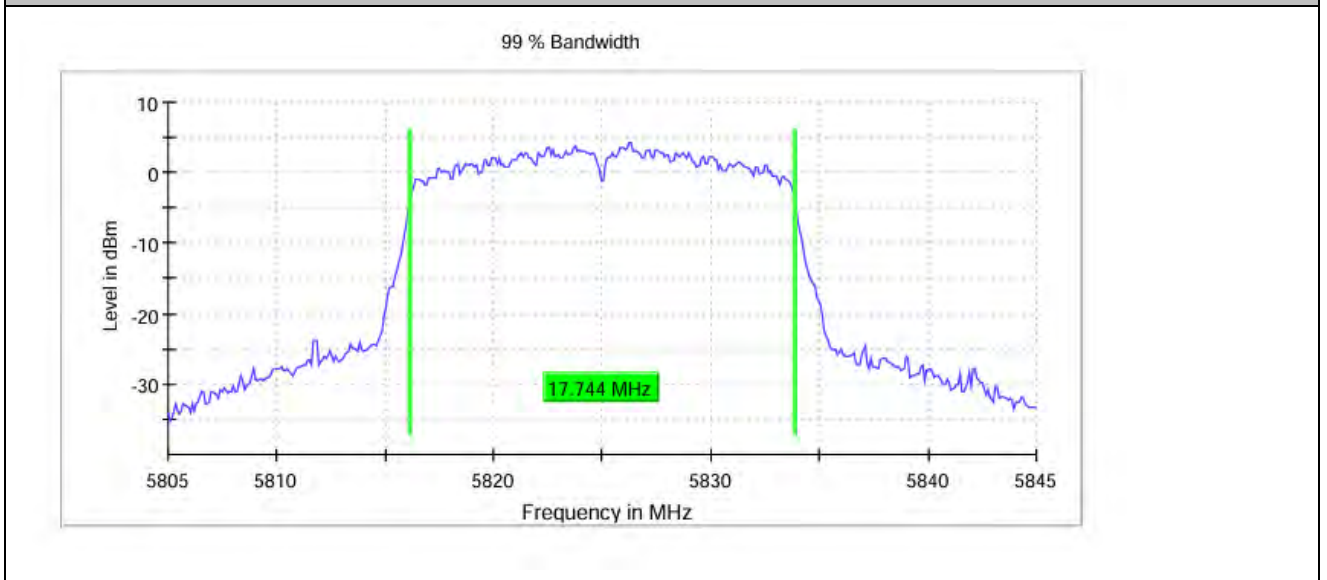

11N40_Ant0_5190



BUREAU
VERITAS

Test Report No.: W7L-240618W002RF03

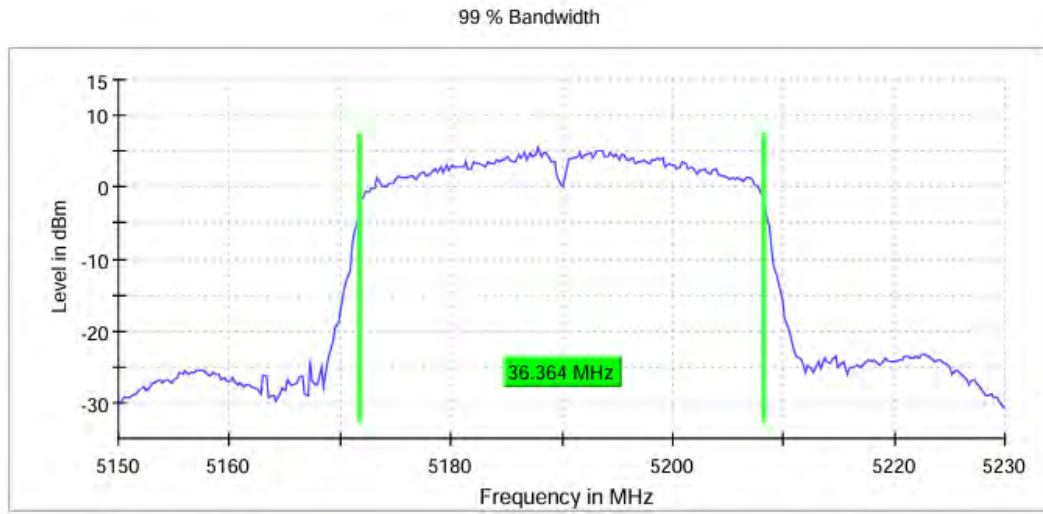

11N40_Ant0_5230

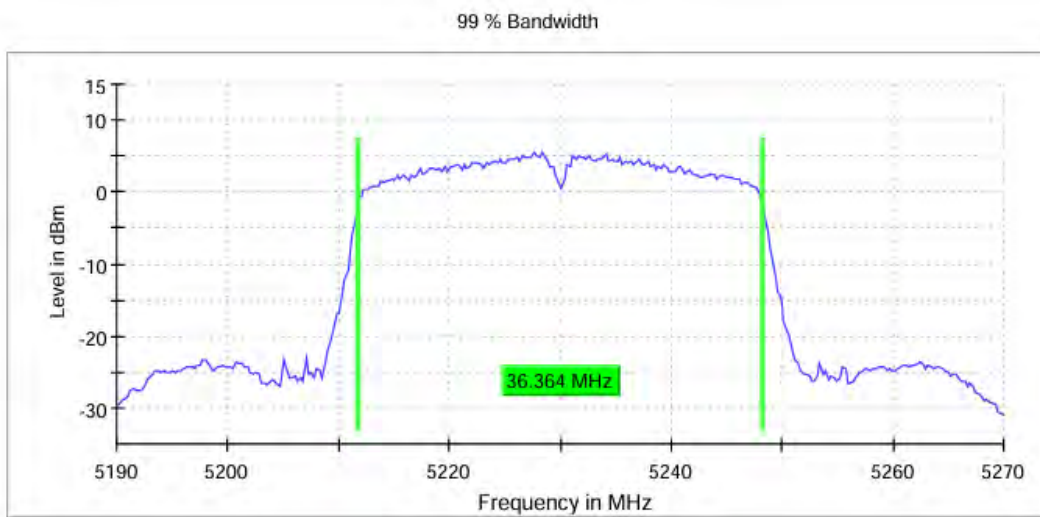

11N40_Ant0_5270



BUREAU
VERITAS

Test Report No.: W7L-240618W002RF03

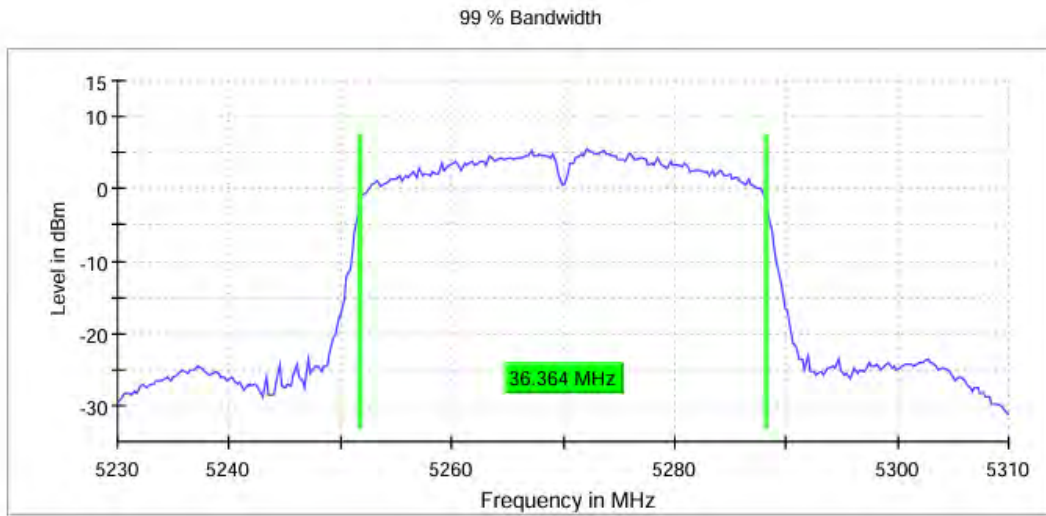

11N40_Ant0_5310

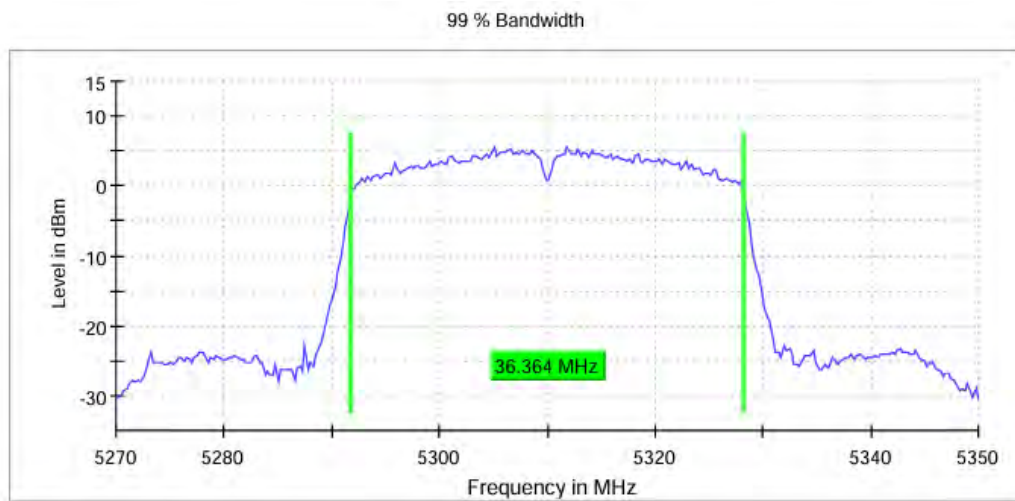

11N40_Ant0_5510



BUREAU
VERITAS

Test Report No.: W7L-240618W002RF03

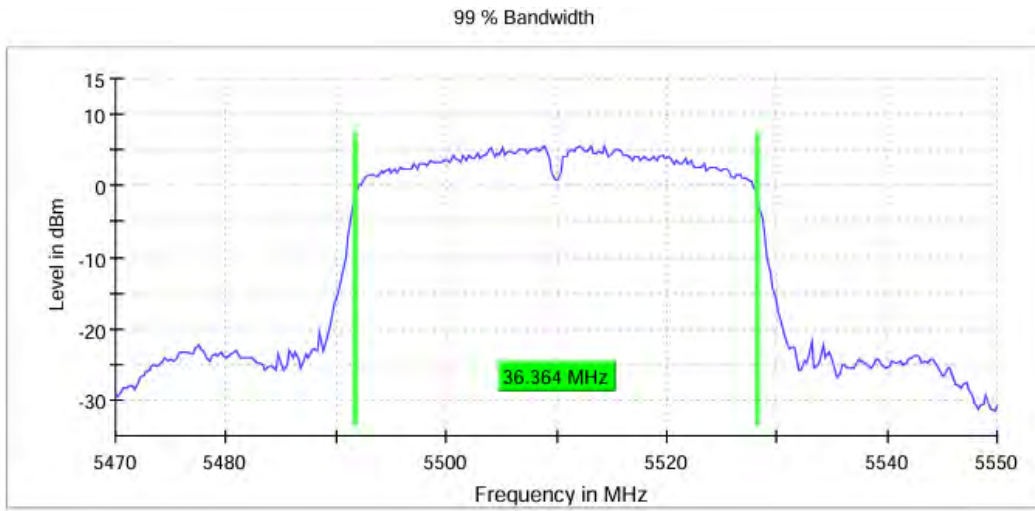

11N40_Ant0_5550

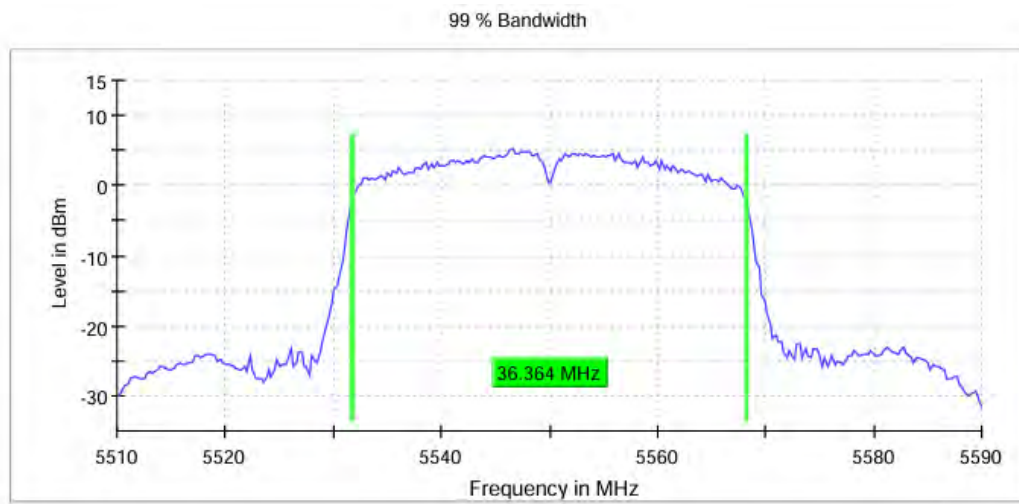

11N40_Ant0_5670

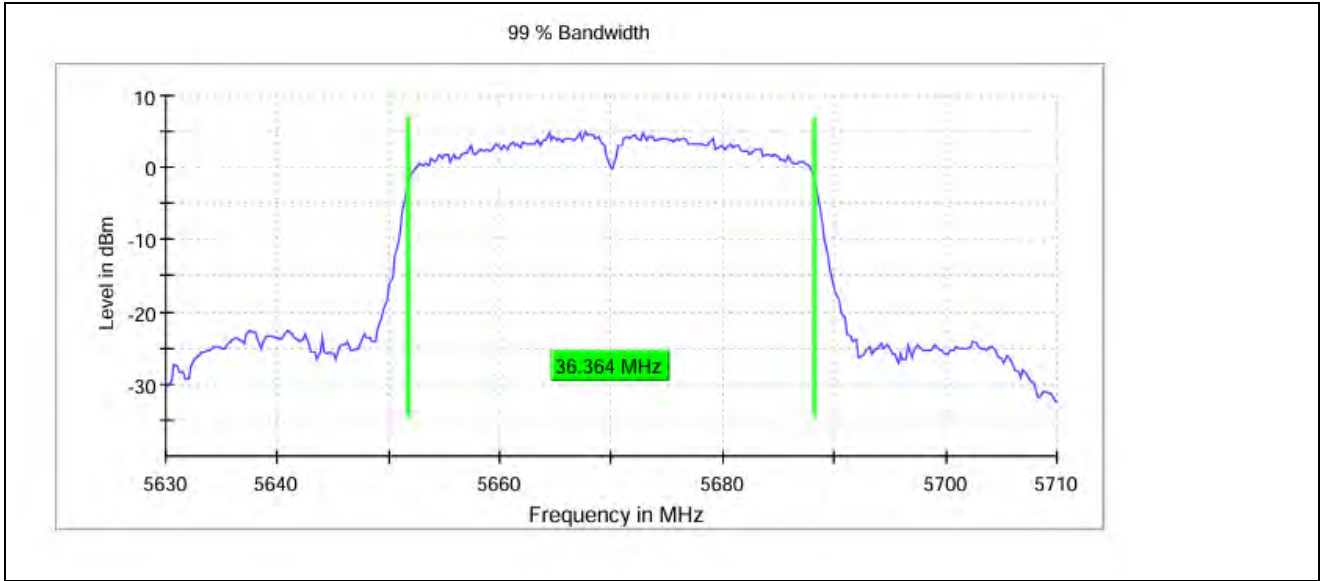

11N40_Ant0_5710

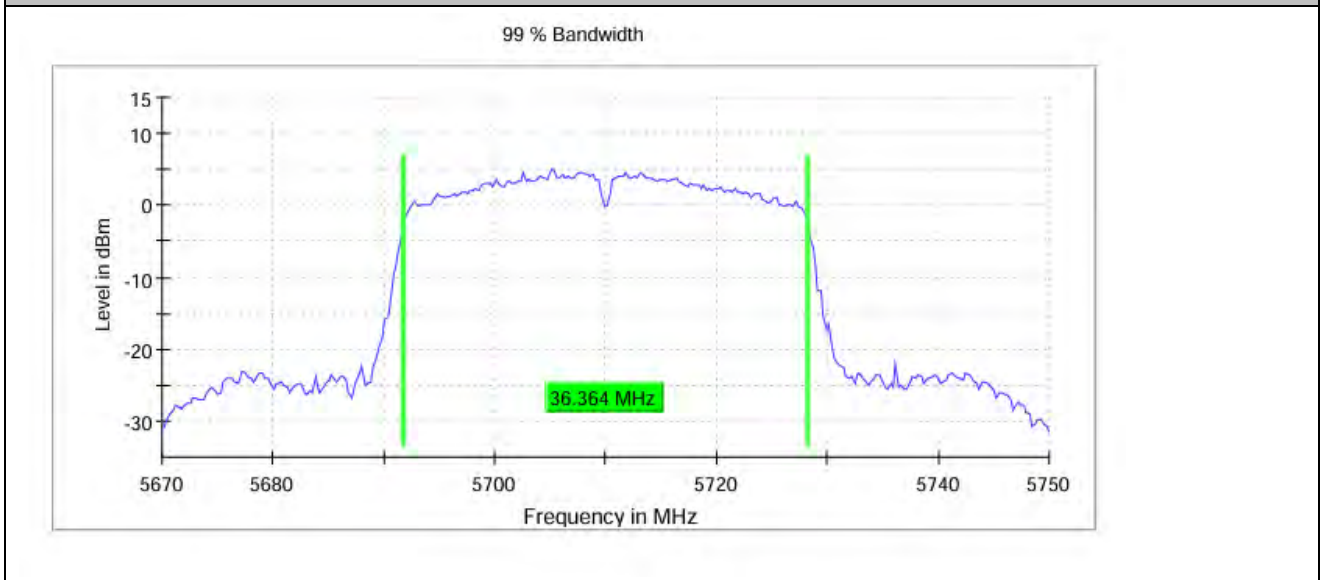

11N40_Ant0_5755



BUREAU
VERITAS

Test Report No.: W7L-240618W002RF03

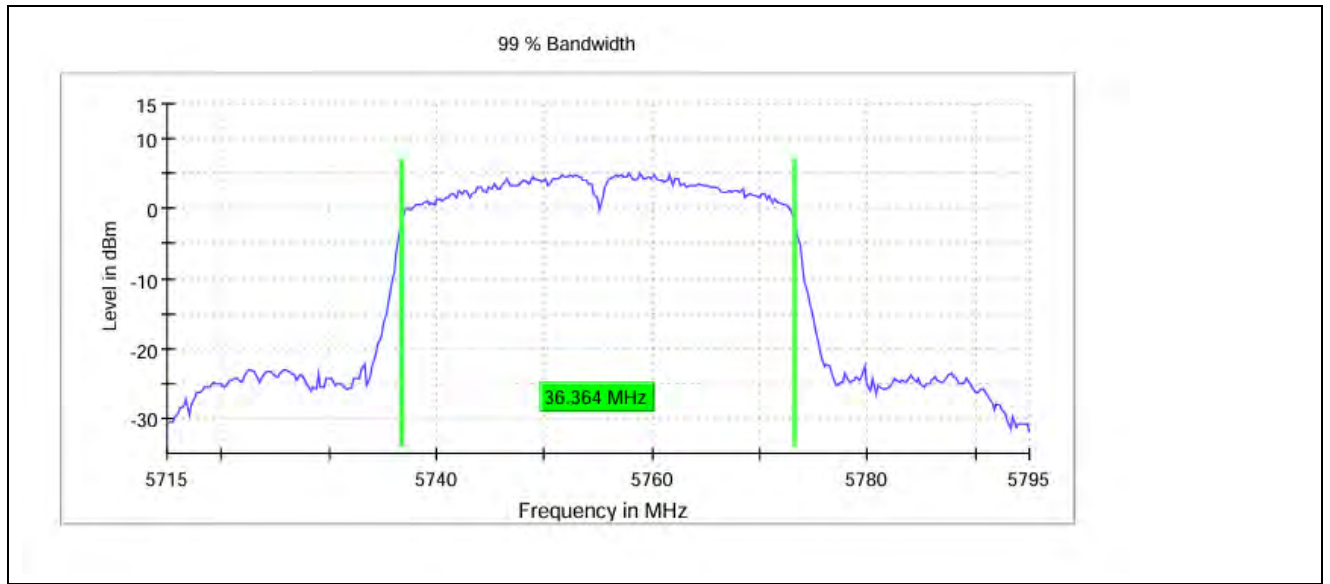

11N40_Ant0_5795

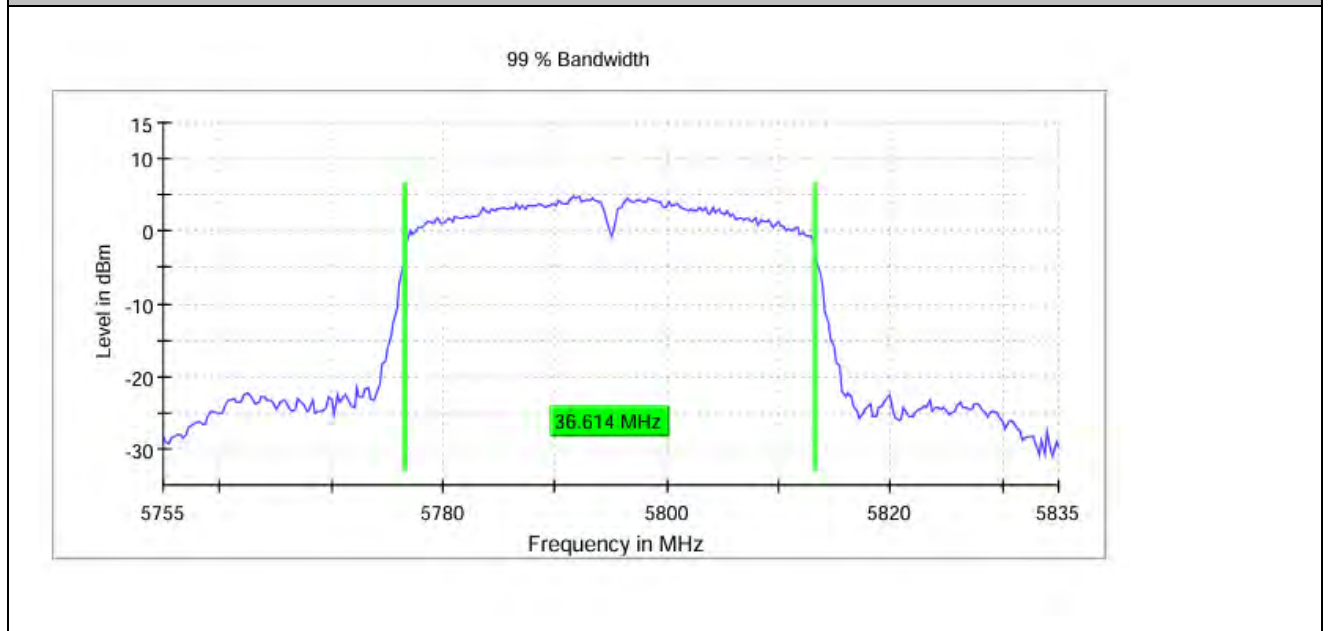

11AC80_Ant0_5210



BUREAU
VERITAS

Test Report No.: W7L-240618W002RF03

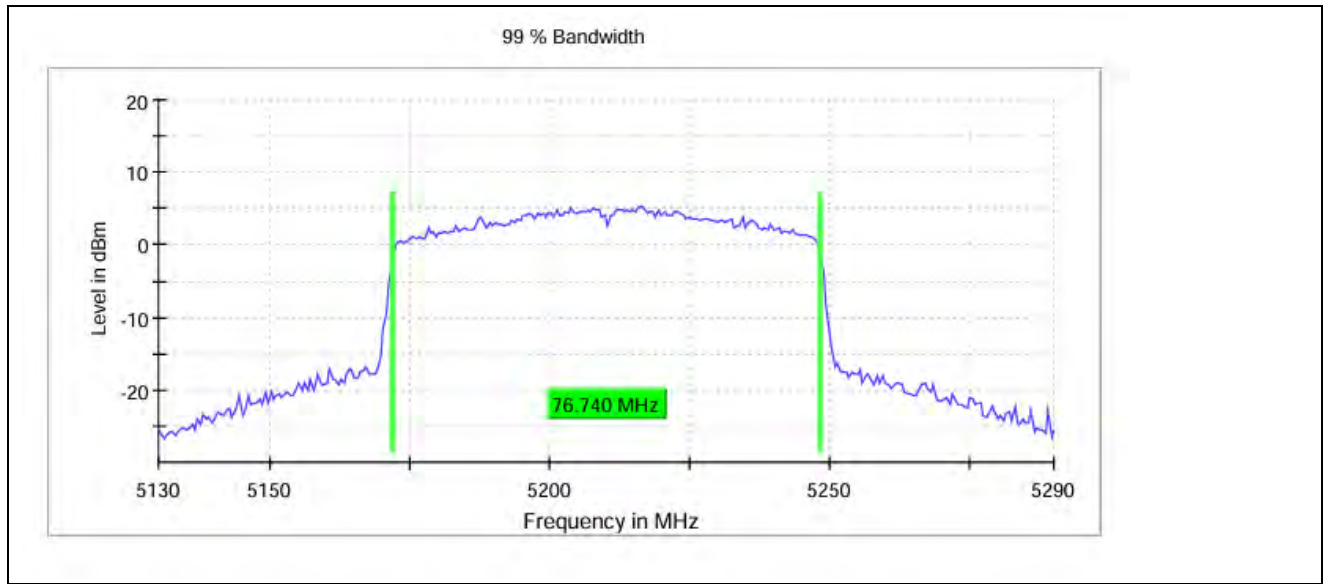

11AC80_Ant0_5290

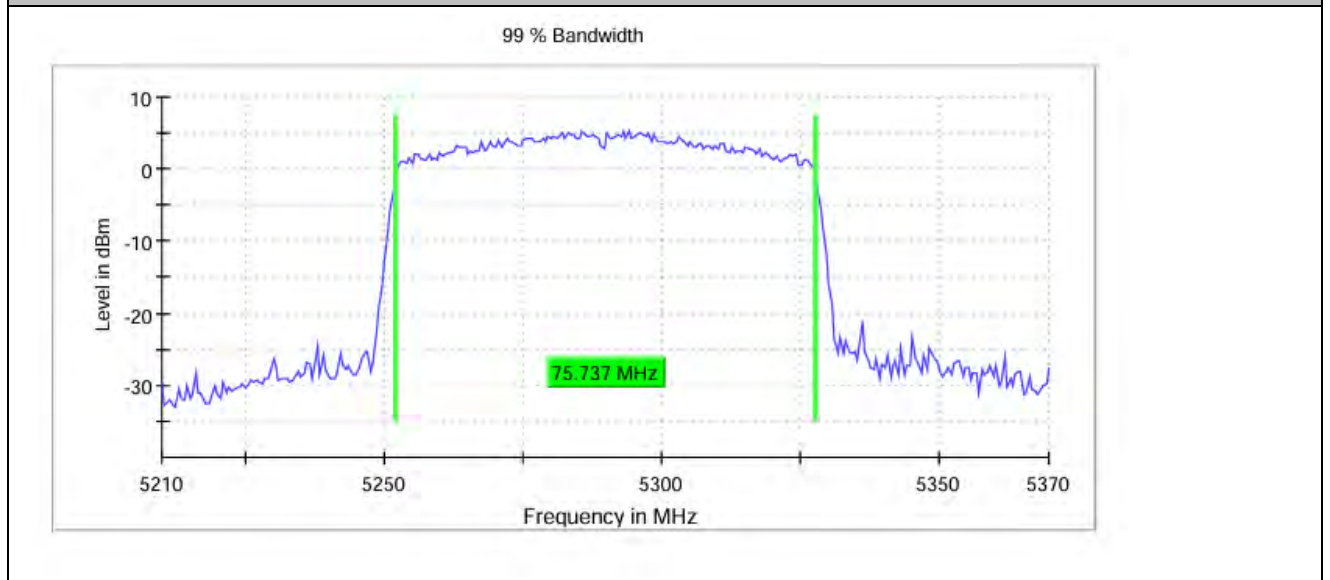

11AC80_Ant0_5530

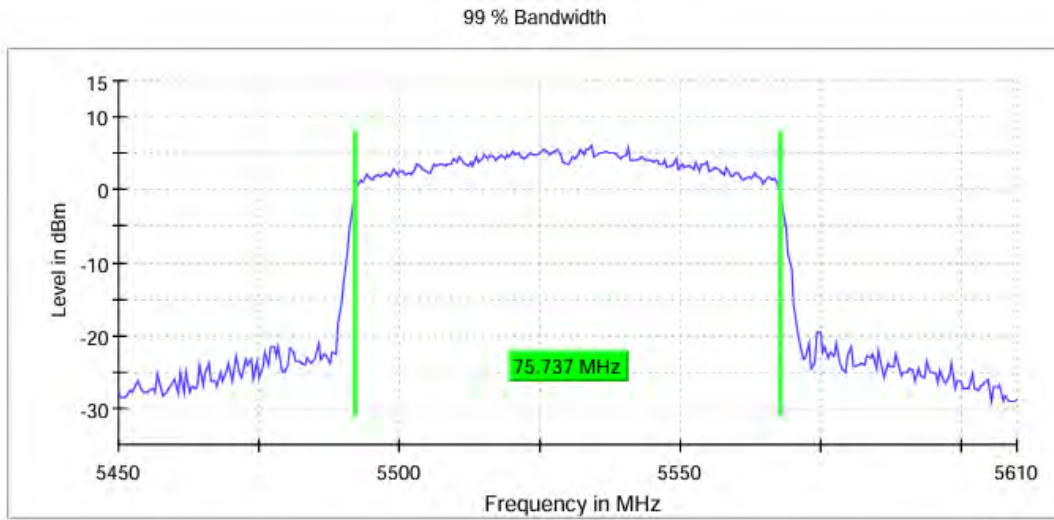

11AC80_Ant0_5610

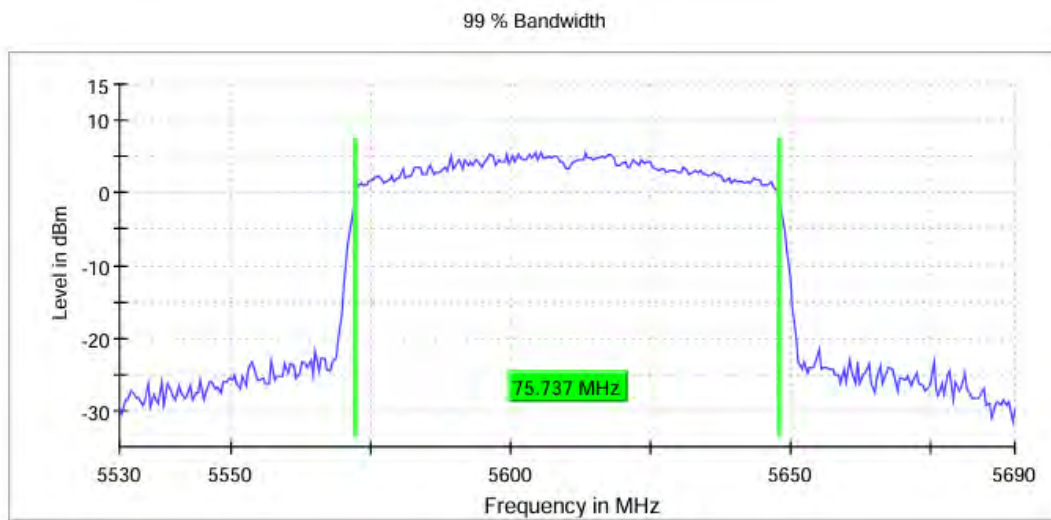

11AC80_Ant0_5690

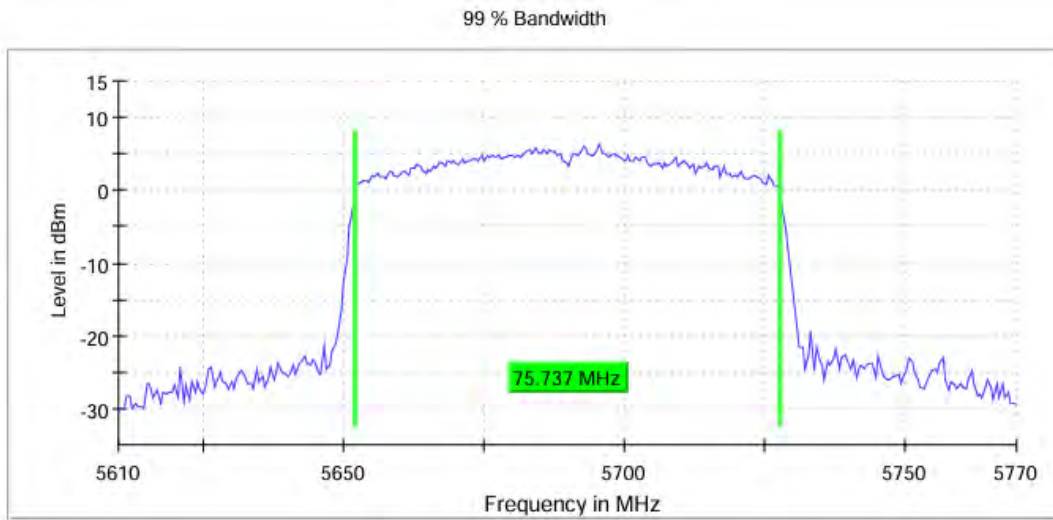

11AC80_Ant0_5775

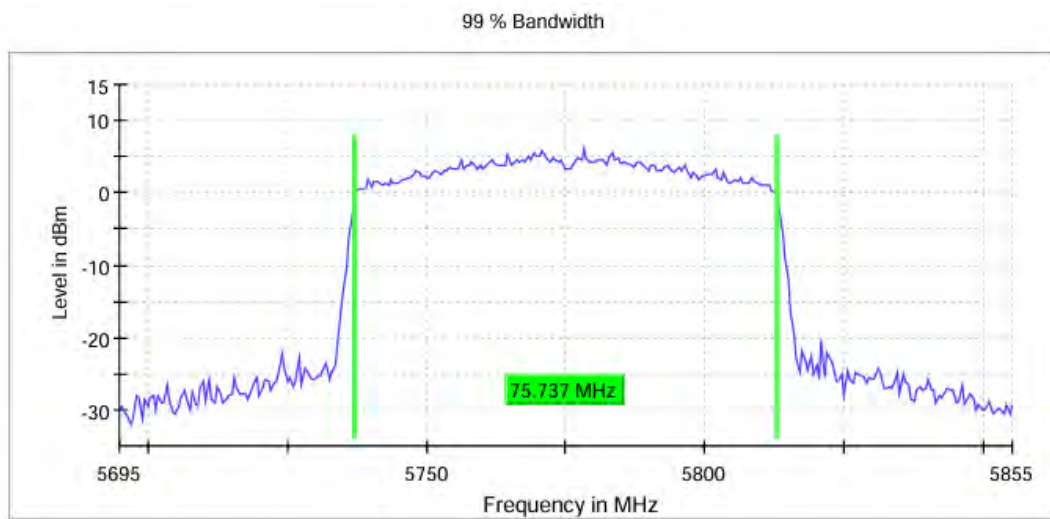

20M

RBW 200.000 kHz

VBW 1.000 MHz

40M

RBW 500.000 kHz

VBW 2.000 MHz

80M

RBW 1.000 MHz

VBW 3.000 MHz



MIN EMISSION BANDWIDTH

TEST RESULT B4

TestMode	Antenna	Frequency [MHz]	6db EBW [MHz]	FL[MHz]	FH[MHz]	Limit[MHz]	Verdict
11A	Ant0	5745	15.219	5737.365	5752.584	0.5	PASS
	Ant0	5785	15.419	5777.165	5792.584	0.5	PASS
	Ant0	5825	15.419	5817.365	5832.784	0.5	PASS
11N20	Ant0	5745	15.219	5737.365	5752.584	0.5	PASS
	Ant0	5785	15.219	5777.365	5792.584	0.5	PASS
	Ant0	5825	15.569	5817.365	5832.934	0.5	PASS
11N40	Ant0	5755	35.222	5737.414	5772.636	0.5	PASS
	Ant0	5795	35.222	5777.414	5812.636	0.5	PASS
11AC80	Ant0	5775	75.224	5737.413	5812.637	0.5	PASS



TEST GRAPHS B4

11A_Ant0_5745

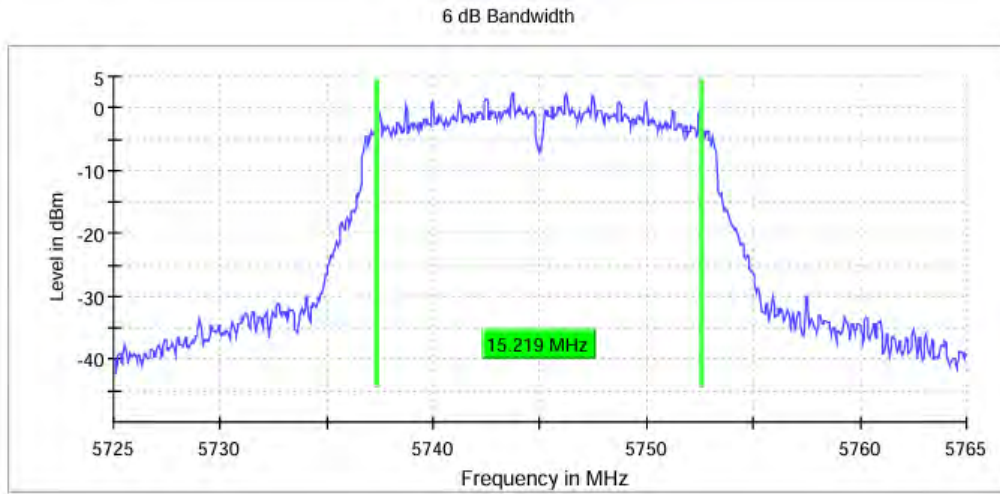

11A_Ant0_5785

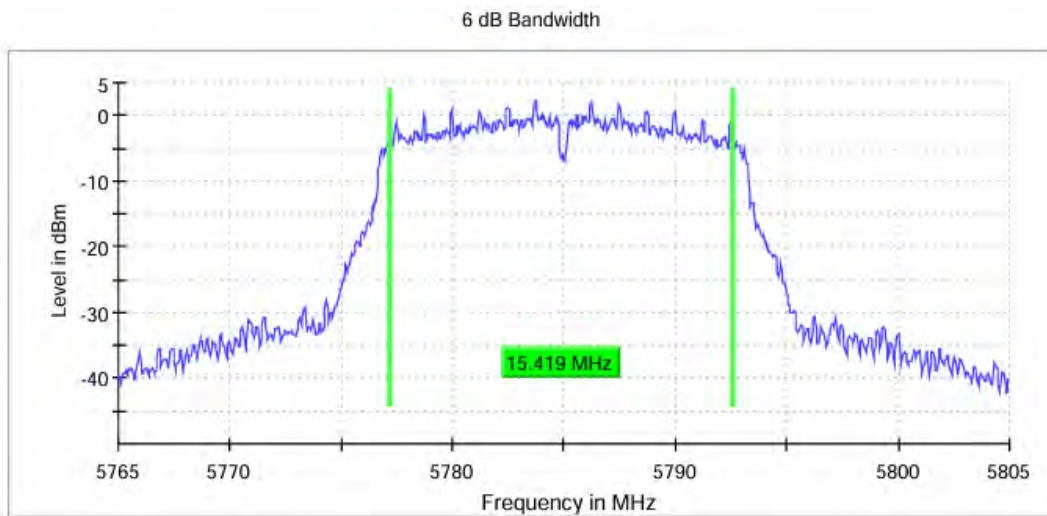

11A_Ant0_5825



BUREAU
VERITAS

Test Report No.: W7L-240618W002RF03

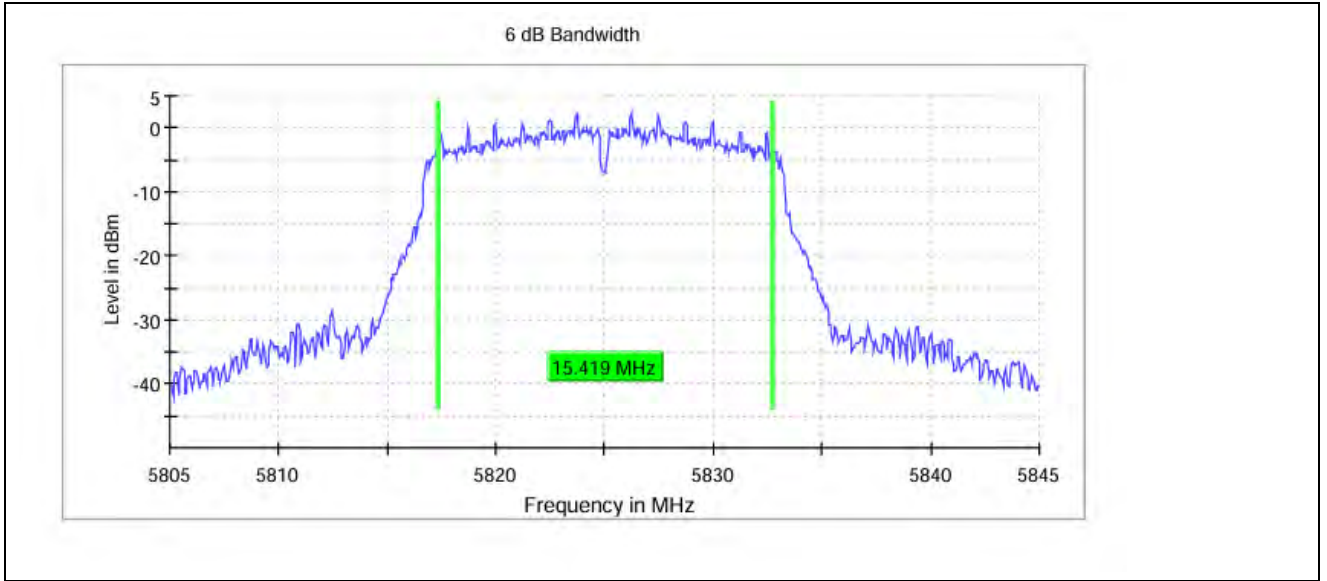

11N20_Ant0_5745

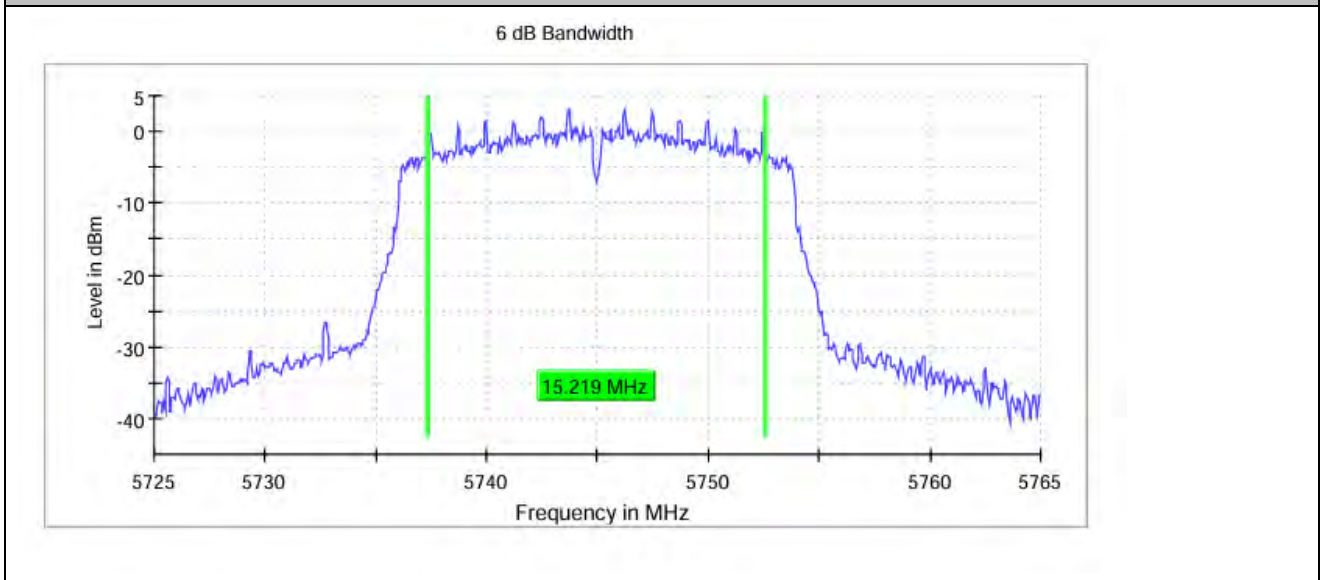

11N20_Ant0_5785

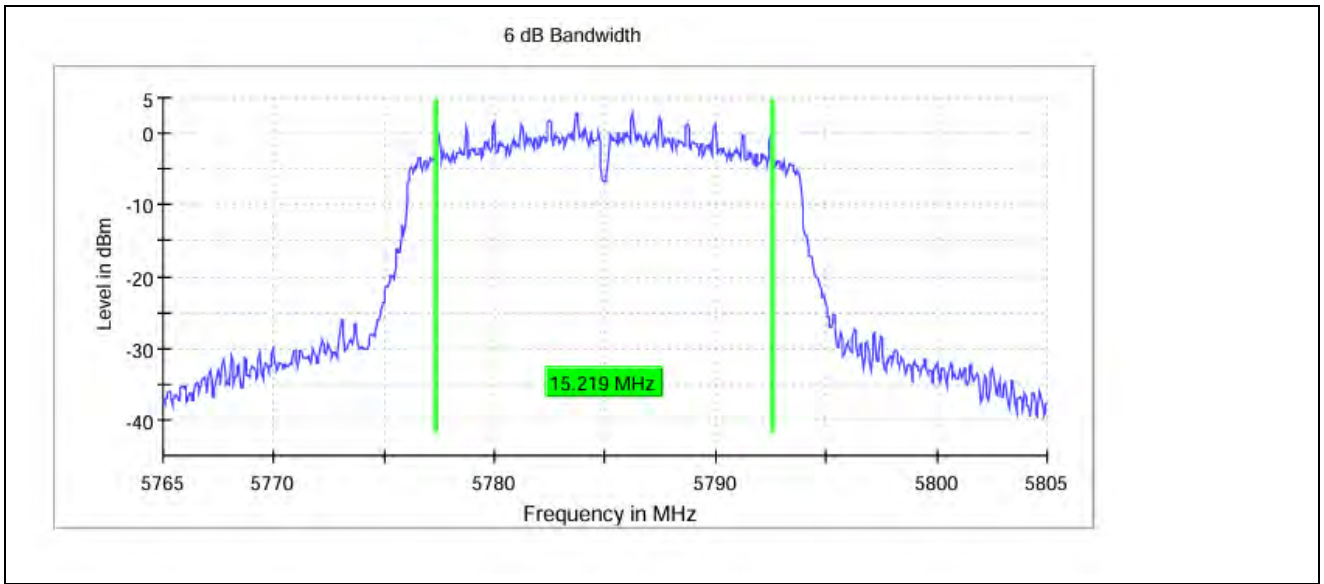

11N20_Ant1_5825

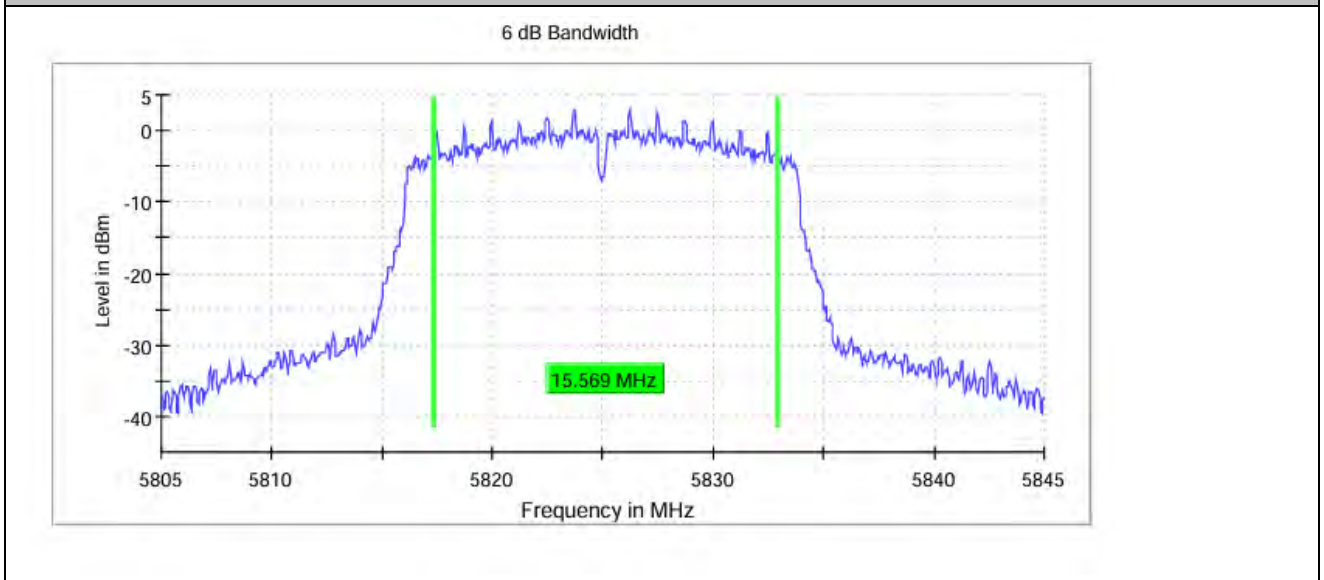

11N40_Ant0_5755

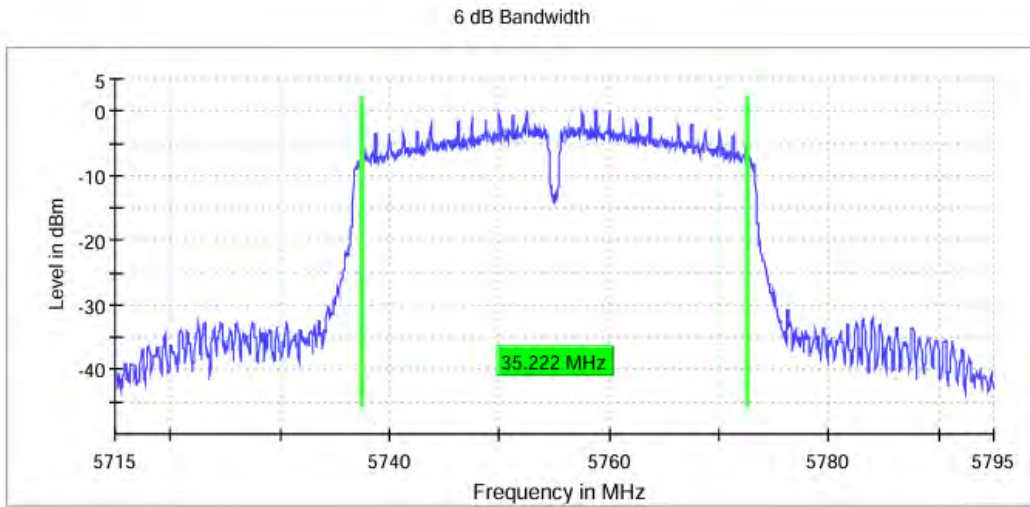

11N40_Ant0_5795

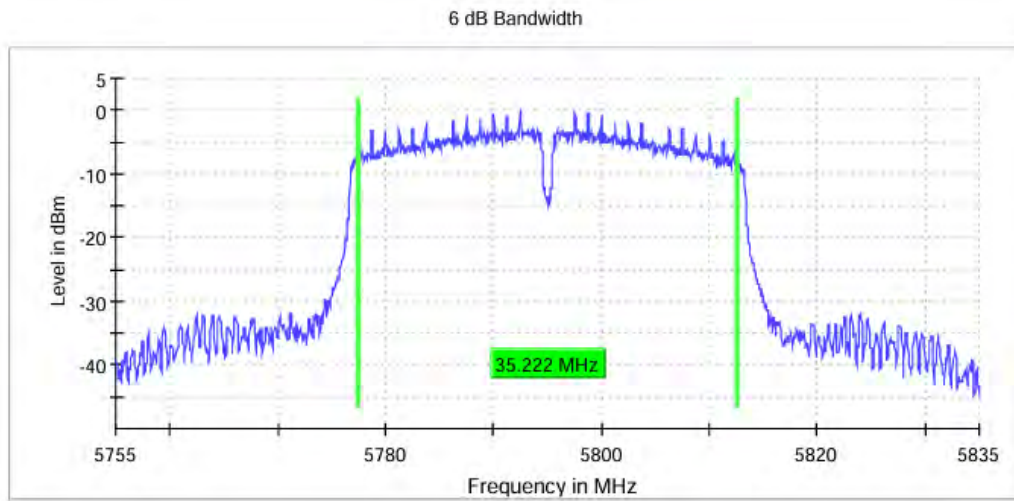

11AC80_Ant0_5775



BUREAU
VERITAS

Test Report No.: W7L-240618W002RF03

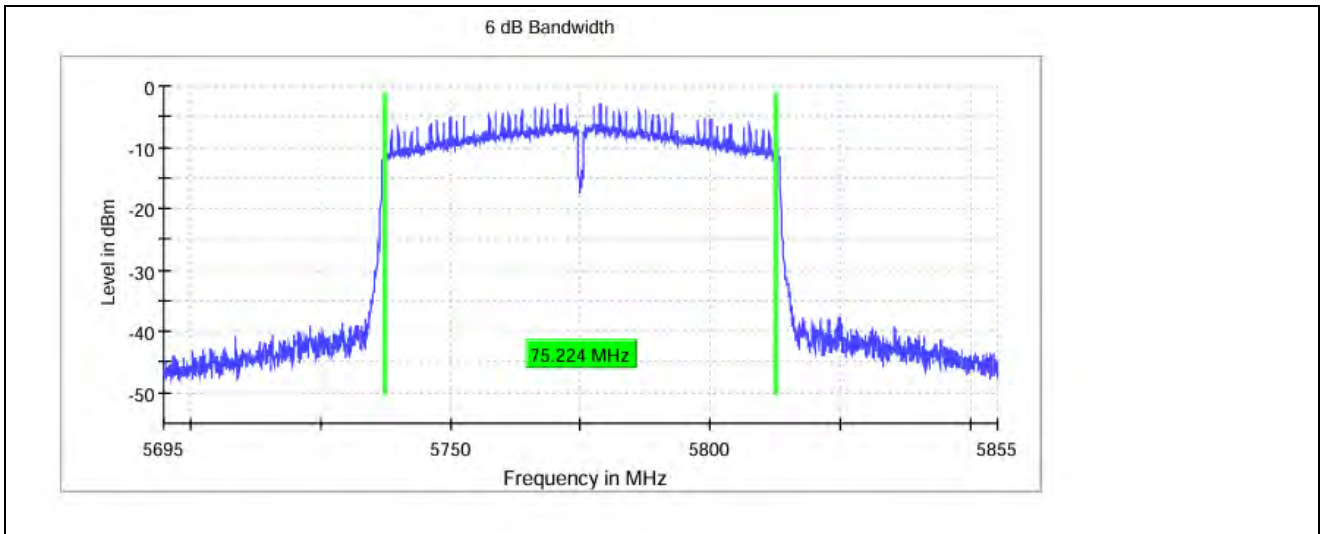

20M

RBW 100.000 kHz

VBW 300.000 kHz

40M

RBW 100.000 kHz

VBW 300.000 kHz

80M

RBW 100.000 kHz

VBW 300.000 kHz



DUTY CYCLE

TEST RESULT

TestMode	Antenna	Frequency[MHz]	Transmission Duration [ms]	Transmission Period [ms]	Duty Cycle [%]	dutycycle factor
11A	Ant0	5180	1.3935	1.4300	97.45%	0.11
	Ant0	5745	1.3920	1.4280	97.48%	0.11
11N20SISO	Ant0	5180	1.2985	1.3350	97.27%	0.12
	Ant0	5745	1.2970	1.3330	97.30%	0.12
11AC20SISO	Ant0	5180	1.3140	1.3490	97.41%	0.11
	Ant0	5745	1.3125	1.3485	97.33%	0.12
11N40SISO	Ant0	5190	0.6485	0.6835	94.88%	0.23
	Ant0	5755	0.6470	0.6830	94.73%	0.24
11AC40SISO	Ant0	5190	0.6525	0.6875	94.91%	0.23
	Ant0	5755	0.6535	0.6885	94.12%	0.26
11AC80SISO	Ant0	5210	0.3240	0.3585	90.38%	0.44
	Ant0	5775	0.3240	0.3585	90.38%	0.44



BUREAU VERITAS

Test Report No.: W7L-240618W002RF03

TEST GRAPHS

11A_Ant0_5180

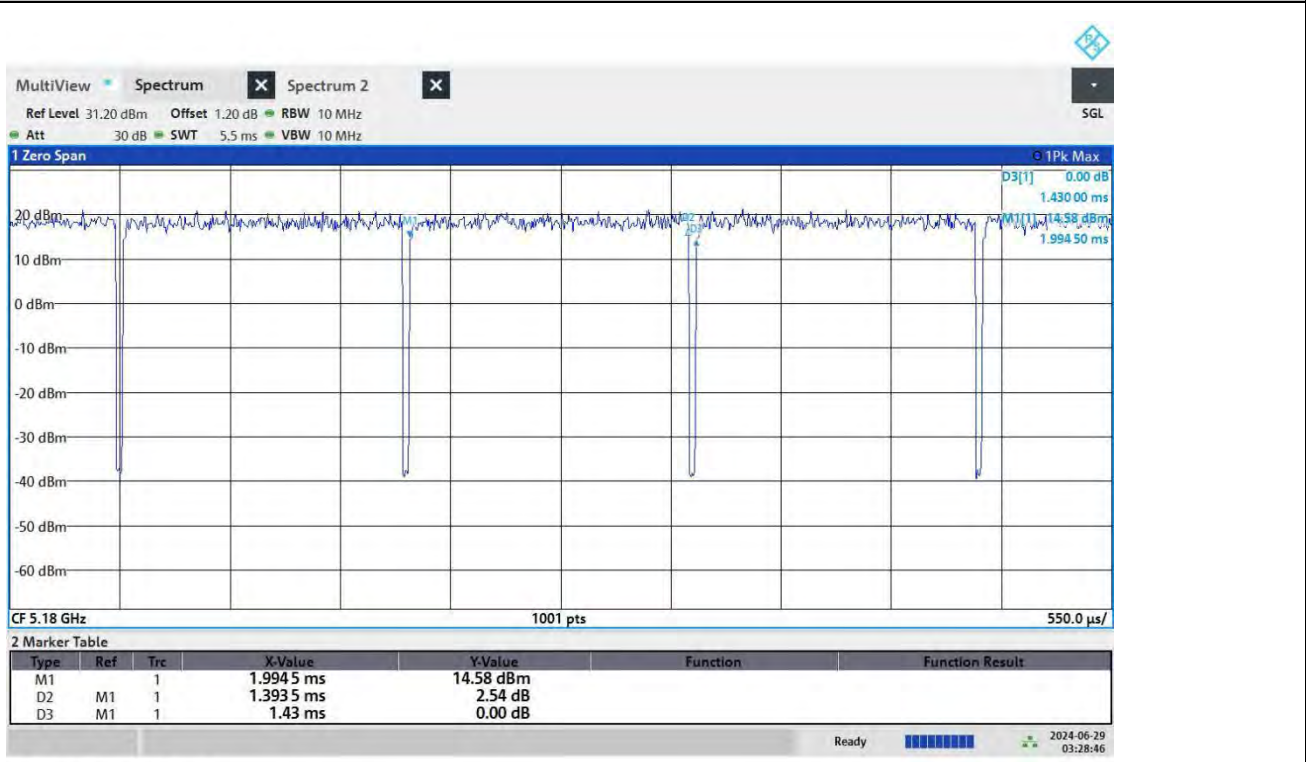

03:28:47 AM 06/29/2024

Band4-11A_Ant0_5745



BUREAU VERITAS

Test Report No.: W7L-240618W002RF03

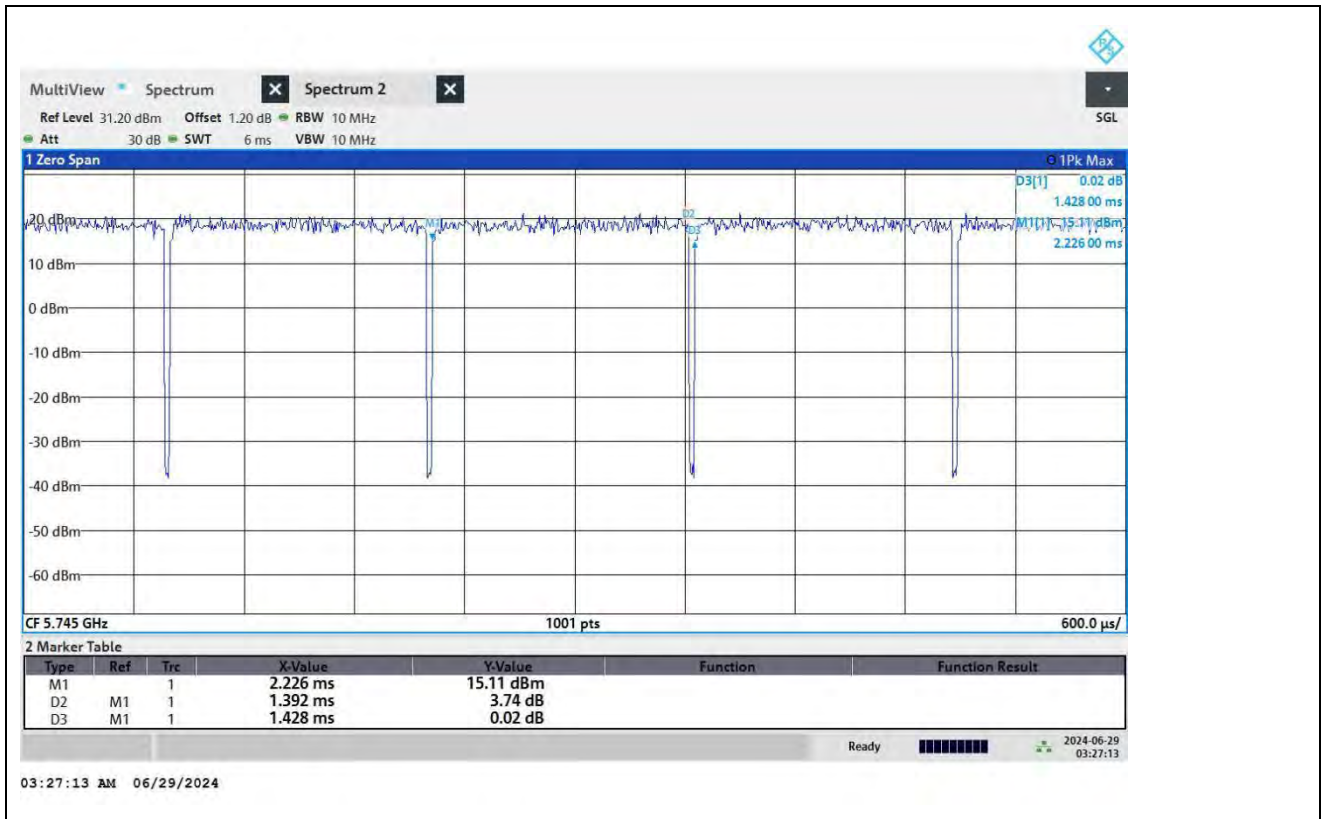

11N20SISO_Ant0_5180



Band4-11N20SISO_Ant0_5745



BUREAU VERITAS

Test Report No.: W7L-240618W002RF03

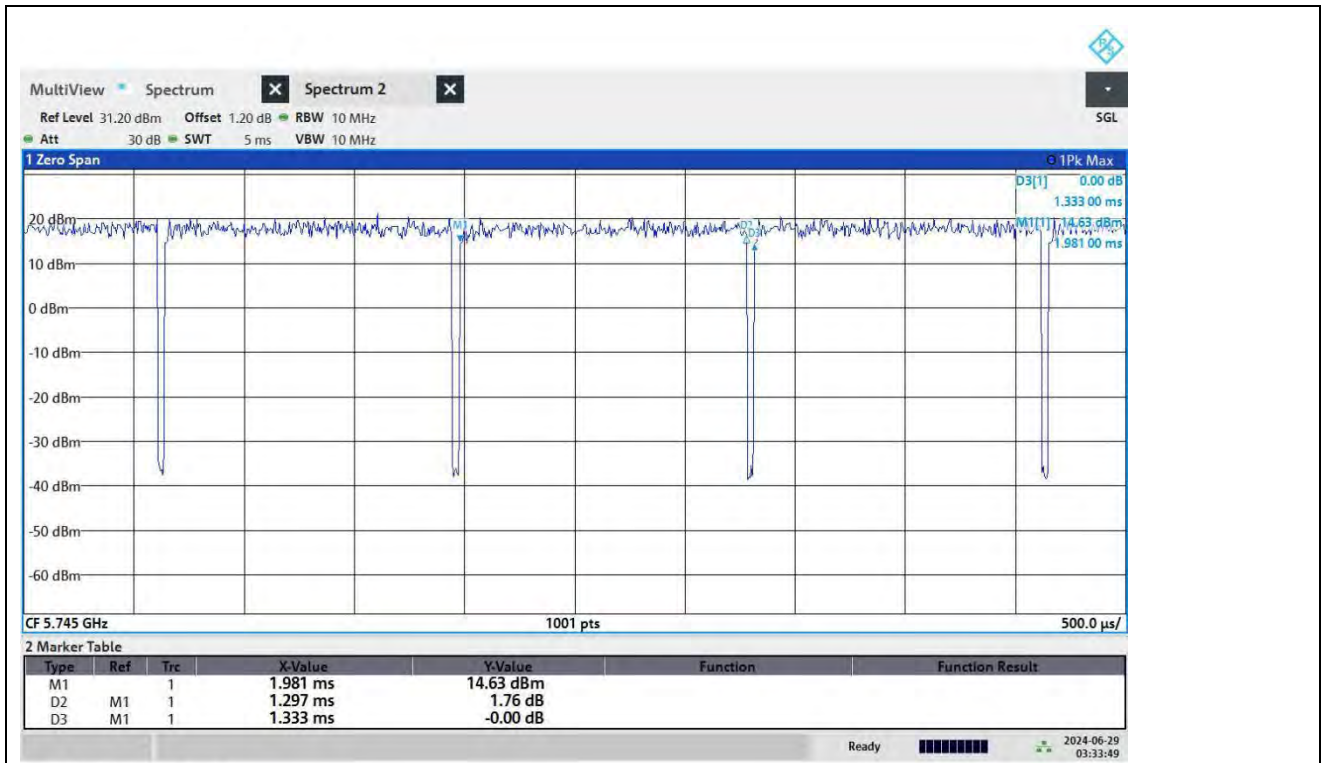

03:33:49 AM 06/29/2024

11AC20SISO_Ant0_5180

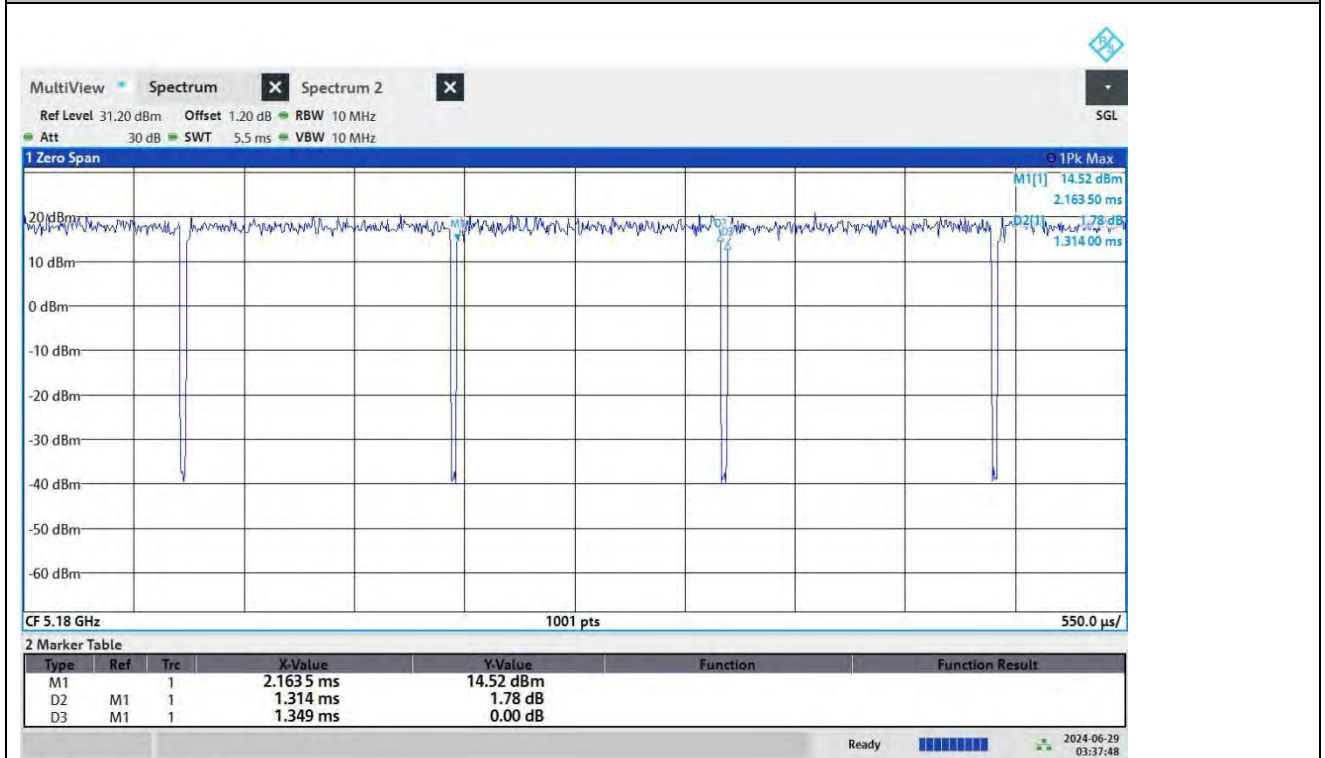

03:37:49 AM 06/29/2024

Band4-11AC20SISO_Ant0_5745



BUREAU VERITAS

Test Report No.: W7L-240618W002RF03

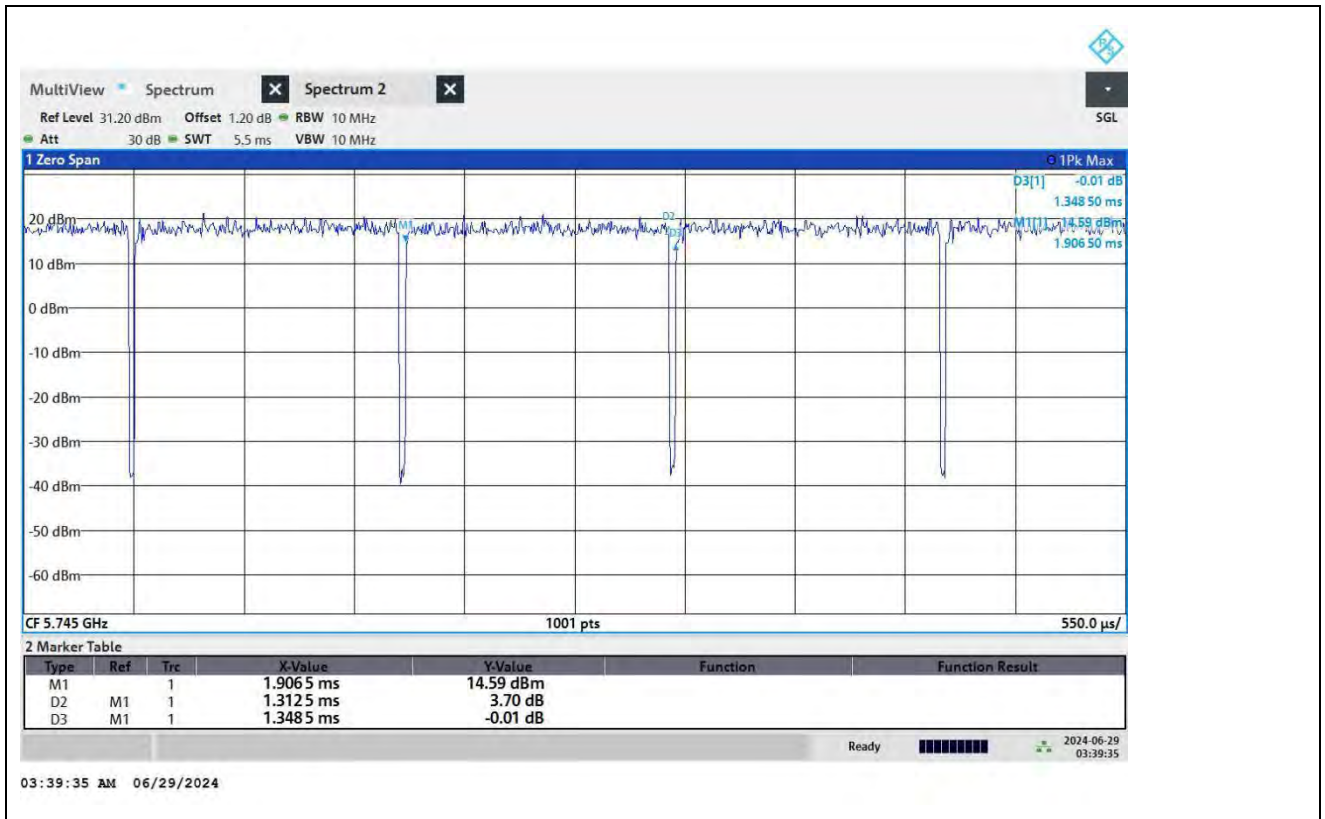

11N40SISO_Ant0_5190

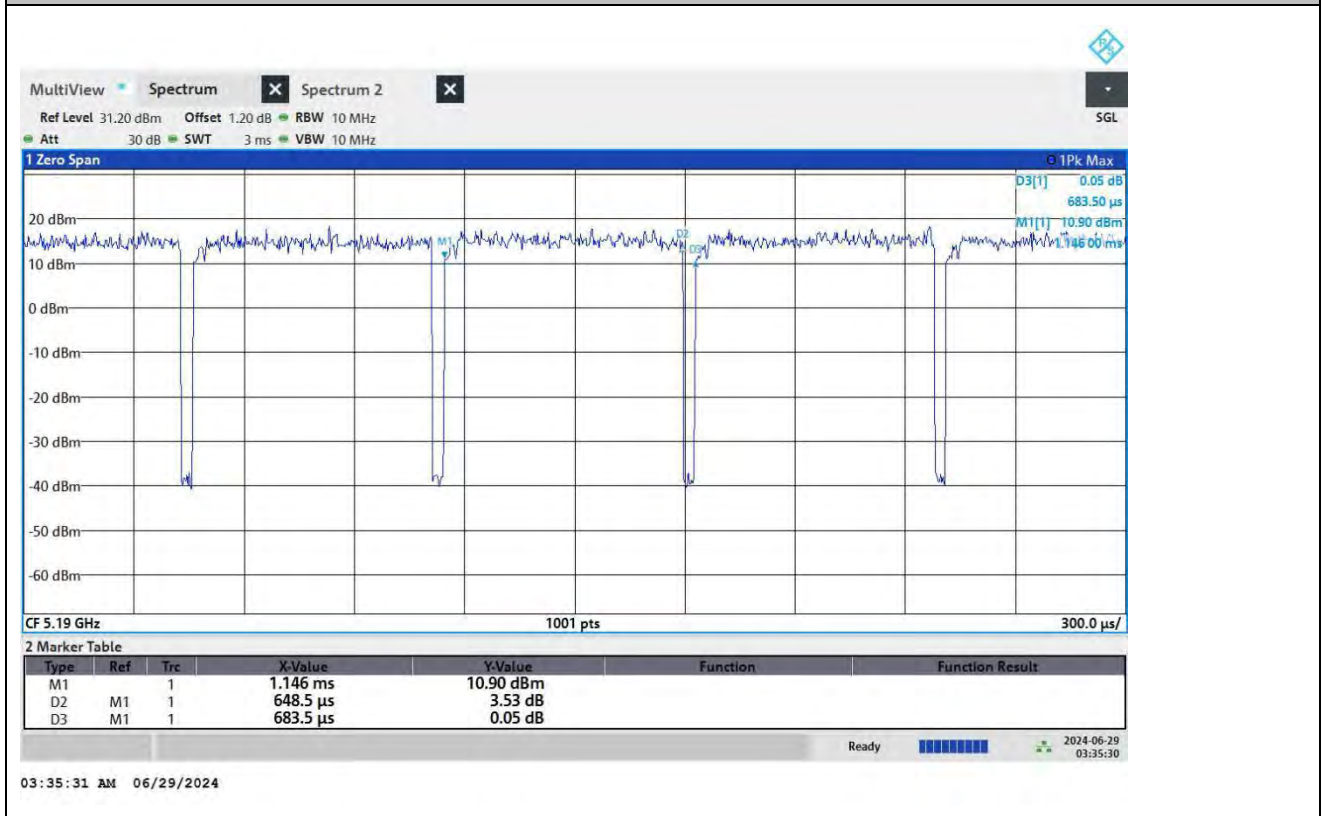

Band4-11N40SISO_Ant0_5755



BUREAU VERITAS

Test Report No.: W7L-240618W002RF03



11AC40SISO_Ant0_5190



Band4-11AC40SISO_Ant0_5755



BUREAU VERITAS

Test Report No.: W7L-240618W002RF03

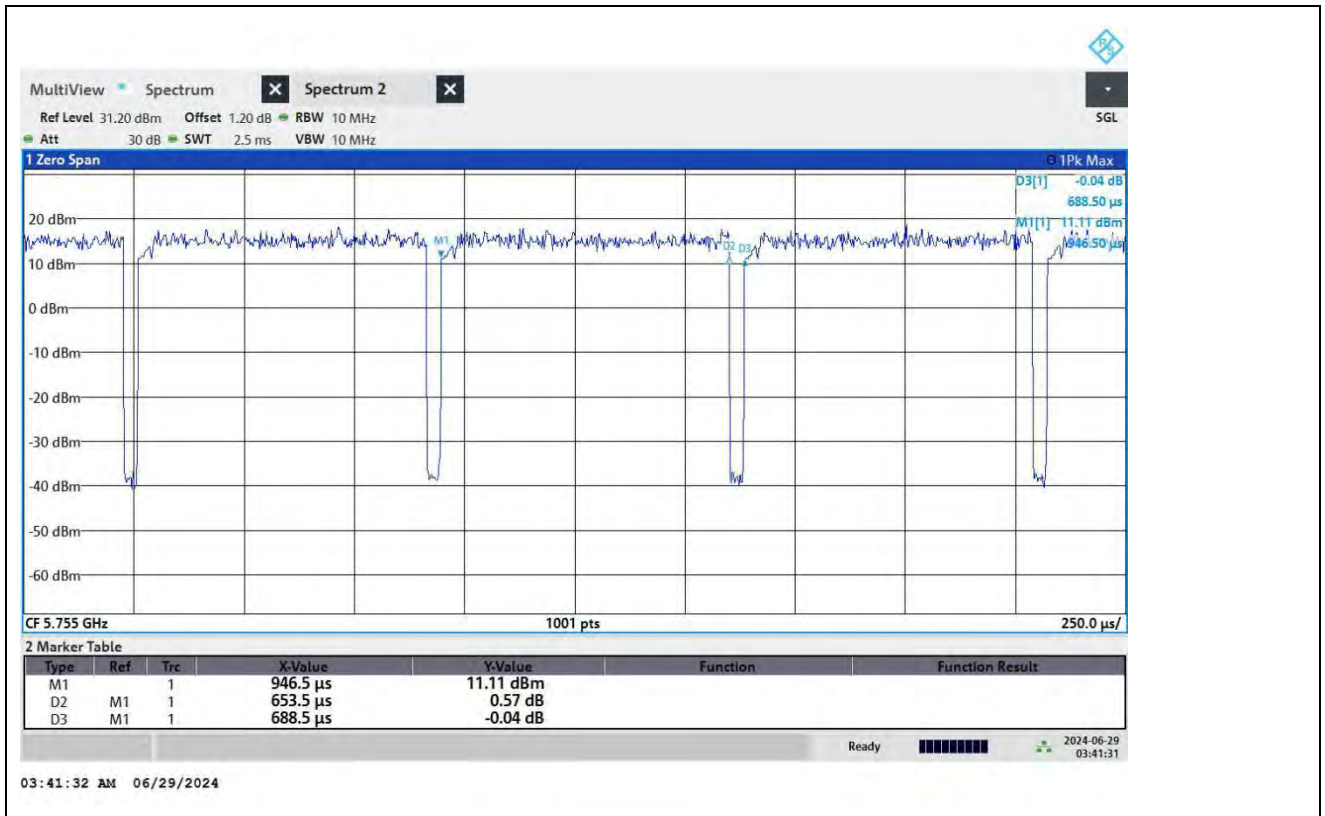

11AC80SISO_Ant0_5210



Band4-11AC80SISO_Ant0_5775

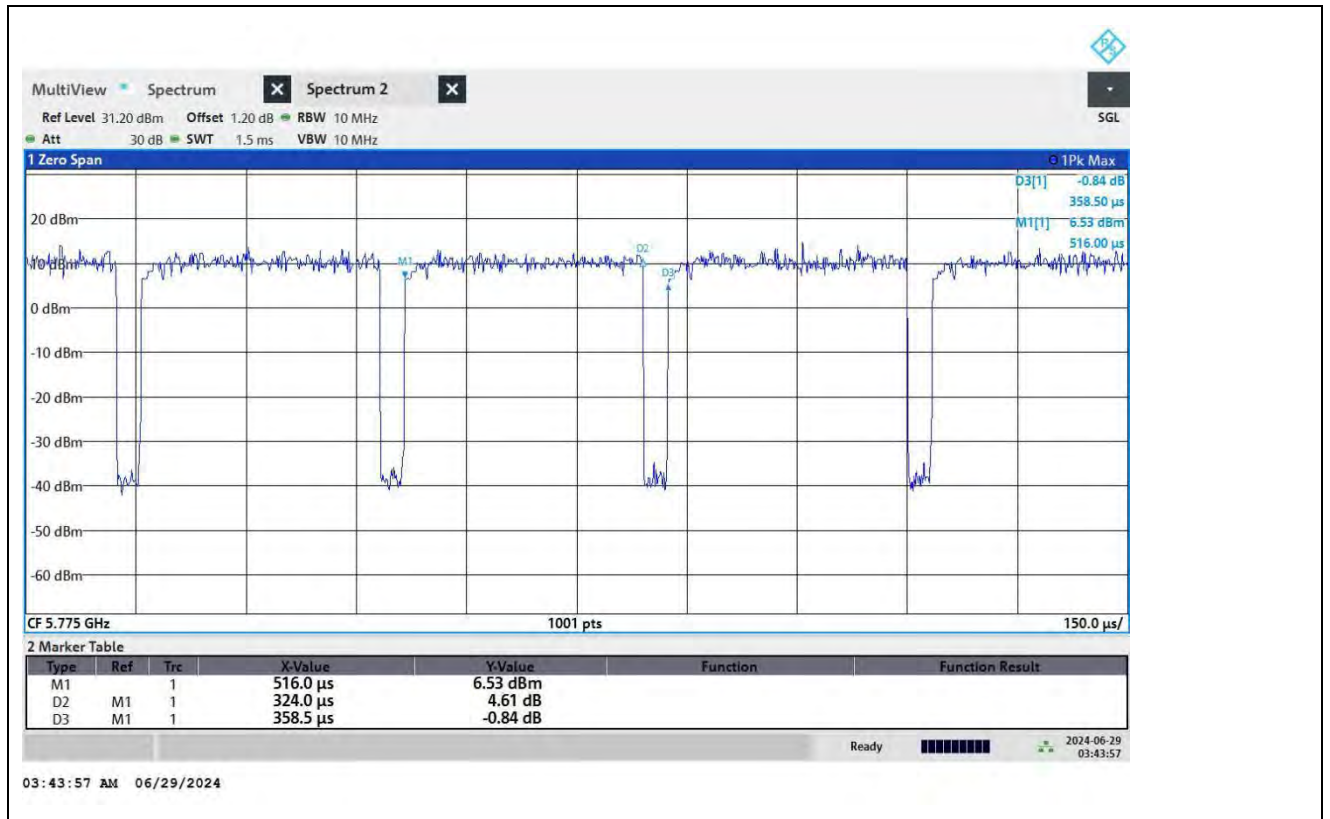



MAXIMUM CONDUCTED OUTPUT POWER

TEST RESULT

BV Power Table For_U-NII-1							
Test Mode	TX Mod.	Freq. (MHz)	Ant.	Maximum Conducted Power (dBm)	FCC Conducted Power Limit (dBm)	Verdict	Power Setting
11A	SISO	5180	Ant1	14.12	≤24.00	Pass	16
		5200	Ant1	14.19	≤24.00	Pass	16
		5240	Ant1	14.29	≤24.00	Pass	16
11N20	SISO	5180	Ant1	14.15	≤24.00	Pass	16
		5200	Ant1	14.17	≤24.00	Pass	16
		5240	Ant1	14.10	≤24.00	Pass	16
11N40	SISO	5190	Ant1	13.68	≤24.00	Pass	15.5
		5230	Ant1	13.62	≤24.00	Pass	15.5
11AC20	SISO	5180	Ant1	13.89	≤24.00	Pass	16
		5200	Ant1	14.14	≤24.00	Pass	16
		5240	Ant1	14.07	≤24.00	Pass	16
11AC40	SISO	5190	Ant1	13.61	≤24.00	Pass	15.5
		5230	Ant1	13.53	≤24.00	Pass	15.5
11AC80	SISO	5210	Ant1	13.09	≤24.00	Pass	15.5

Note: The Maximum Conducted Power with duty cycle factor.



BV Power Table For_U-NII-2A							
Test Mode	TX Mod.	Freq. (MHz)	Ant.	Maximum Conducted Power (dBm)	FCC Conducted Power Limit (dBm)	Verdict	Power Setting
11A	SISO	5260	Ant1	14.18	≤24.00	Pass	16
		5300	Ant1	14.45	≤24.00	Pass	16
		5320	Ant1	14.27	≤24.00	Pass	16
11N20	SISO	5260	Ant1	14.09	≤24.00	Pass	16
		5300	Ant1	14.49	≤24.00	Pass	16
		5320	Ant1	14.20	≤24.00	Pass	16
11N40	SISO	5270	Ant1	13.74	≤24.00	Pass	15.5
		5310	Ant1	13.85	≤24.00	Pass	15.5
11AC20	SISO	5260	Ant1	14.09	≤24.00	Pass	16
		5300	Ant1	14.33	≤24.00	Pass	16
		5320	Ant1	14.19	≤24.00	Pass	16
11AC40	SISO	5270	Ant1	13.60	≤24.00	Pass	15.5
		5310	Ant1	13.64	≤24.00	Pass	15.5
11AC80	SISO	5210	Ant1	12.88	≤24.00	Pass	15.5
Note:The Maximum Conducted Power with duty cycle factor.							



BV Power Table For_U-NII-2C							
Test Mode	TX Mod.	Freq. (MHz)	Ant.	Maximum Conducted Power (dBm)	FCC Conducted Power Limit (dBm)	Verdict	Power Setting
11A	SISO	5500	Ant1	14.10	≤24.00	Pass	16
		5580	Ant1	14.31	≤24.00	Pass	16
		5700	Ant1	14.69	≤24.00	Pass	16
		5720	Ant1	14.53	≤24.00	Pass	16
11N20	SISO	5500	Ant1	14.13	≤24.00	Pass	16
		5580	Ant1	14.30	≤24.00	Pass	16
		5700	Ant1	14.82	≤24.00	Pass	16
		5720	Ant1	14.48	≤24.00	Pass	16
11N40	SISO	5510	Ant1	13.71	≤24.00	Pass	15.5
		5550	Ant1	13.55	≤24.00	Pass	15.5
		5670	Ant1	14.14	≤24.00	Pass	15.5
		5710	Ant1	14.01	≤24.00	Pass	15.5
11AC20	SISO	5500	Ant1	14.04	≤24.00	Pass	16
		5580	Ant1	14.12	≤24.00	Pass	16
		5700	Ant1	14.81	≤24.00	Pass	16
		5720	Ant1	14.41	≤24.00	Pass	16
11AC40	SISO	5510	Ant1	13.59	≤24.00	Pass	15.5
		5550	Ant1	13.54	≤24.00	Pass	15.5
		5670	Ant1	14.03	≤24.00	Pass	15.5
		5710	Ant1	13.97	≤24.00	Pass	15.5
11AC80	SISO	5530	Ant1	12.82	≤24.00	Pass	15.5
	SISO	5690	Ant1	13.05	≤24.00	Pass	15.5
Note: The Maximum Conducted Power with duty cycle factor.							



BV Power Table For_U-NII-3							
Test Mode	TX Mod.	Freq. (MHz)	Ant.	Maximum Conducted Power (dBm)	Conducted Power Limit (dBm)	Verdict	Power Setting
11A	SISO	5745	Ant1	13.88	≤30.00	Pass	15
		5785	Ant1	13.93	≤30.00	Pass	15
		5825	Ant1	13.86	≤30.00	Pass	15
11N20	SISO	5745	Ant1	14.44	≤30.00	Pass	15
		5785	Ant1	14.35	≤30.00	Pass	
		5825	Ant1	14.39	≤30.00	Pass	15
11N40	SISO	5755	Ant1	14.34	≤30.00	Pass	15
		5795	Ant1	14.37	≤30.00	Pass	15
11AC20	SISO	5745	Ant1	14.27	≤30.00	Pass	15
		5785	Ant1	14.24	≤30.00	Pass	
		5825	Ant1	14.25	≤30.00	Pass	15
11AC40	SISO	5755	Ant1	14.30	≤30.00	Pass	15
		5795	Ant1	14.23	≤30.00	Pass	
11AC80	SISO	5775	Ant1	13.39	≤30.00	Pass	15
Note:The Maximum Conducted Power with duty cycle factor.							



MAXIMUM POWER SPECTRAL DENSITY

TEST RESULT

TestMode	Antenna	Frequency[MHz]	Result [dBm/MHz]	PSD Limit [dBm/MHz]	Verdict
11A	Ant0	5180	2.412	≤11.00	Pass
	Ant0	5200	2.892	≤11.00	Pass
	Ant0	5240	2.959	≤11.00	Pass
	Ant0	5260	3.056	≤11.00	Pass
	Ant0	5300	3.328	≤11.00	Pass
	Ant0	5320	3.167	≤11.00	Pass
	Ant0	5500	3.169	≤11.00	Pass
	Ant0	5580	3.173	≤11.00	Pass
	Ant0	5700	3.031	≤11.00	Pass
	Ant0	5720	2.899	≤11.00	Pass
	Ant0	5745	-0.739	≤30.00	Pass
	Ant0	5785	-0.734	≤30.00	Pass
	Ant0	5825	-0.819	≤30.00	Pass
11N20	Ant0	5180	2.439	≤11.00	Pass
	Ant0	5200	2.774	≤11.00	Pass
	Ant0	5240	2.776	≤11.00	Pass
	Ant0	5260	2.746	≤11.00	Pass
	Ant0	5300	3.029	≤11.00	Pass
	Ant0	5320	2.856	≤11.00	Pass
	Ant0	5500	3.023	≤11.00	Pass
	Ant0	5580	2.788	≤11.00	Pass
	Ant0	5700	2.980	≤11.00	Pass
	Ant0	5720	2.570	≤11.00	Pass
	Ant0	5745	-0.368	≤30.00	Pass
	Ant0	5785	-0.438	≤30.00	Pass
	Ant0	5825	-0.587	≤30.00	Pass
11N40	Ant0	5190	-0.673	≤11.00	Pass



	Ant0	5230	-0.735	≤11.00	Pass
	Ant0	5270	-0.653	≤11.00	Pass
	Ant0	5310	-0.457	≤11.00	Pass
	Ant0	5510	-0.452	≤11.00	Pass
	Ant0	5550	-0.842	≤11.00	Pass
	Ant0	5670	-1.008	≤11.00	Pass
	Ant0	5710	-0.931	≤11.00	Pass
	Ant0	5755	-3.561	≤30.00	Pass
	Ant0	5795	-3.937	≤30.00	Pass
11AC80	Ant0	5210	-4.674	≤11.00	Pass
	Ant0	5290	-4.654	≤11.00	Pass
	Ant0	5530	-4.755	≤11.00	Pass
	Ant0	5610	-4.951	≤11.00	Pass
	Ant0	5690	-4.250	≤11.00	Pass
	Ant0	5775	-7.766	≤30.00	Pass

Note: 1.PPSD is EIRP PSD



TEST GRAPHS

11A_Ant0_5180

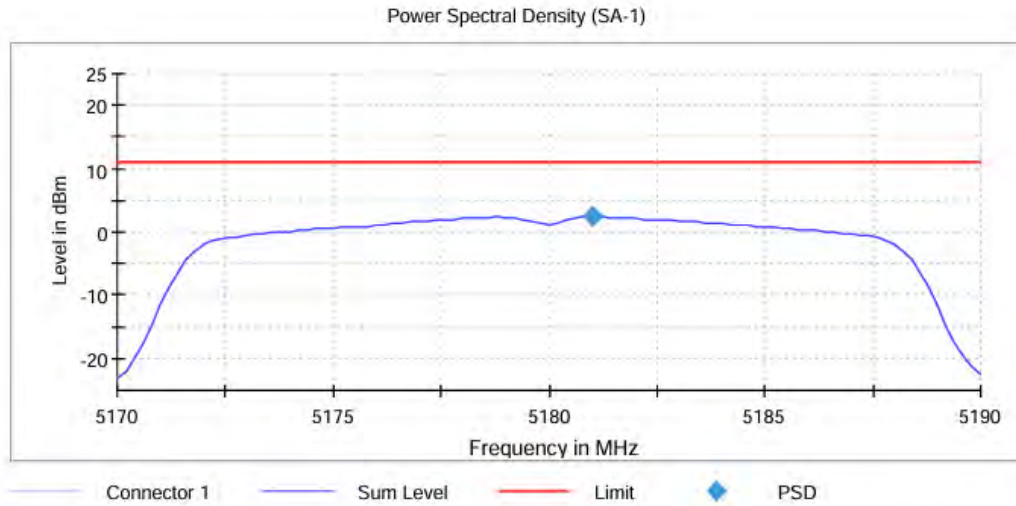

11A_Ant0_5200

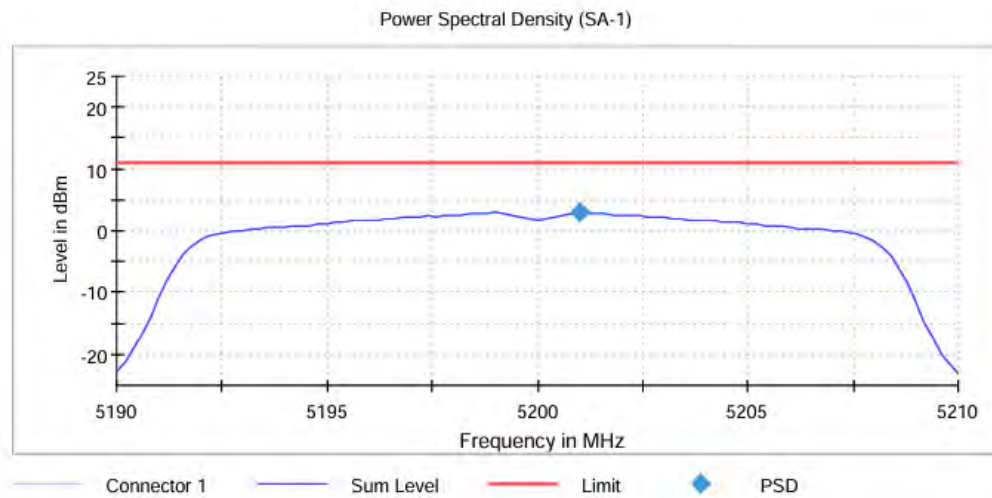

11A_Ant0_5240

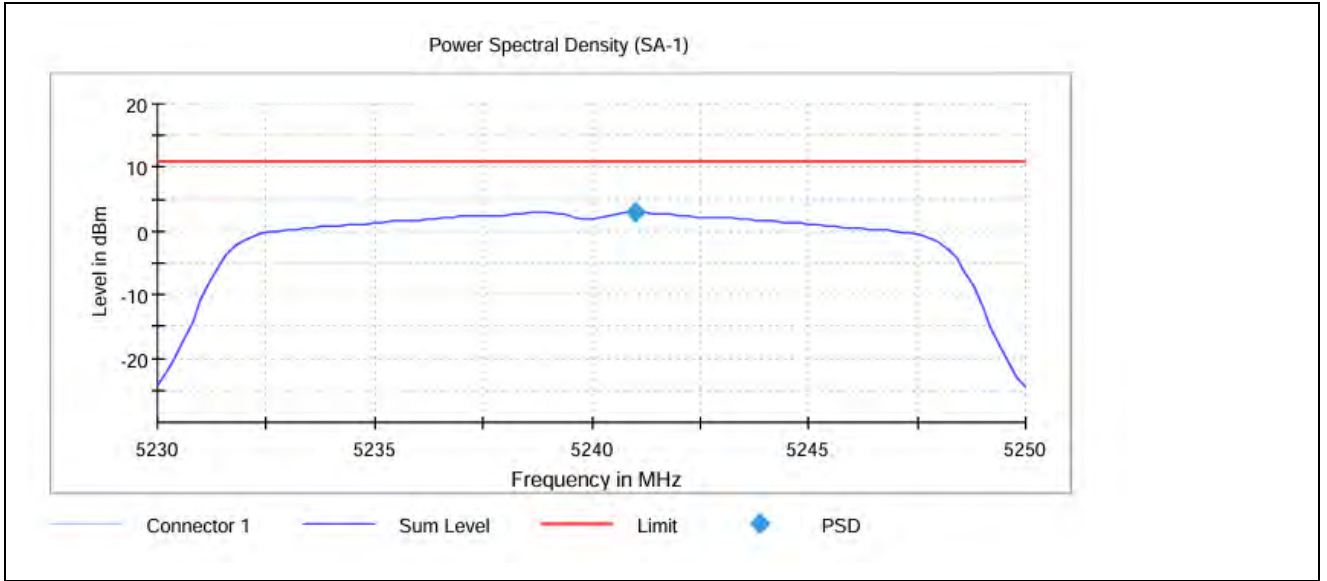

11A_Ant0_5260

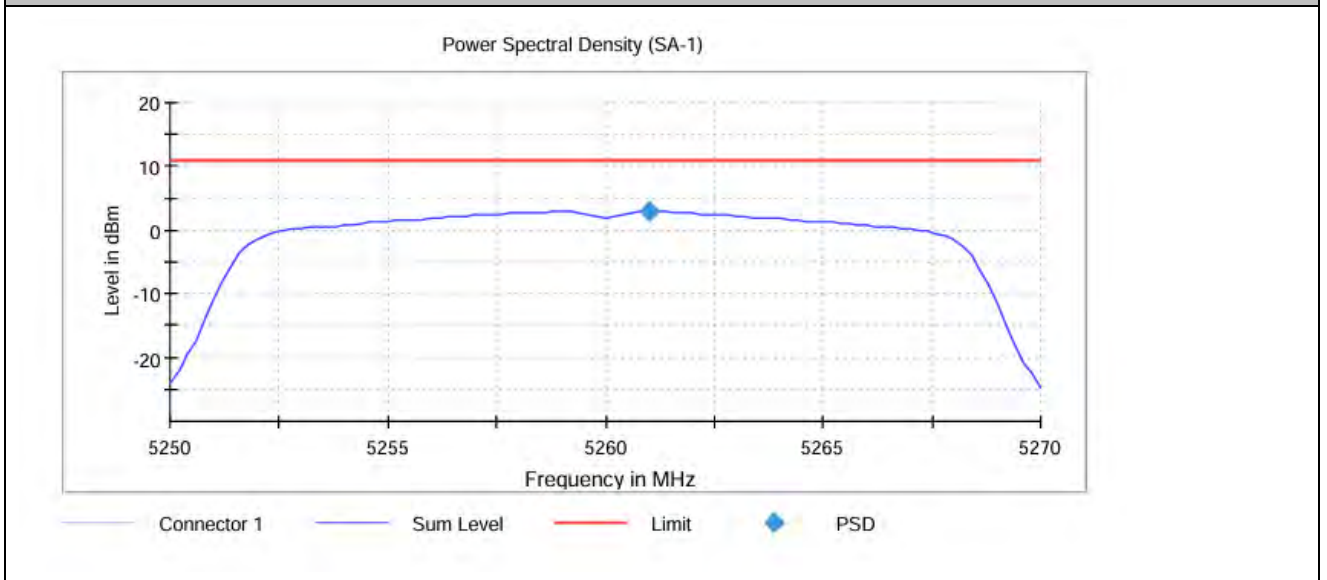

11A_Ant0_5300

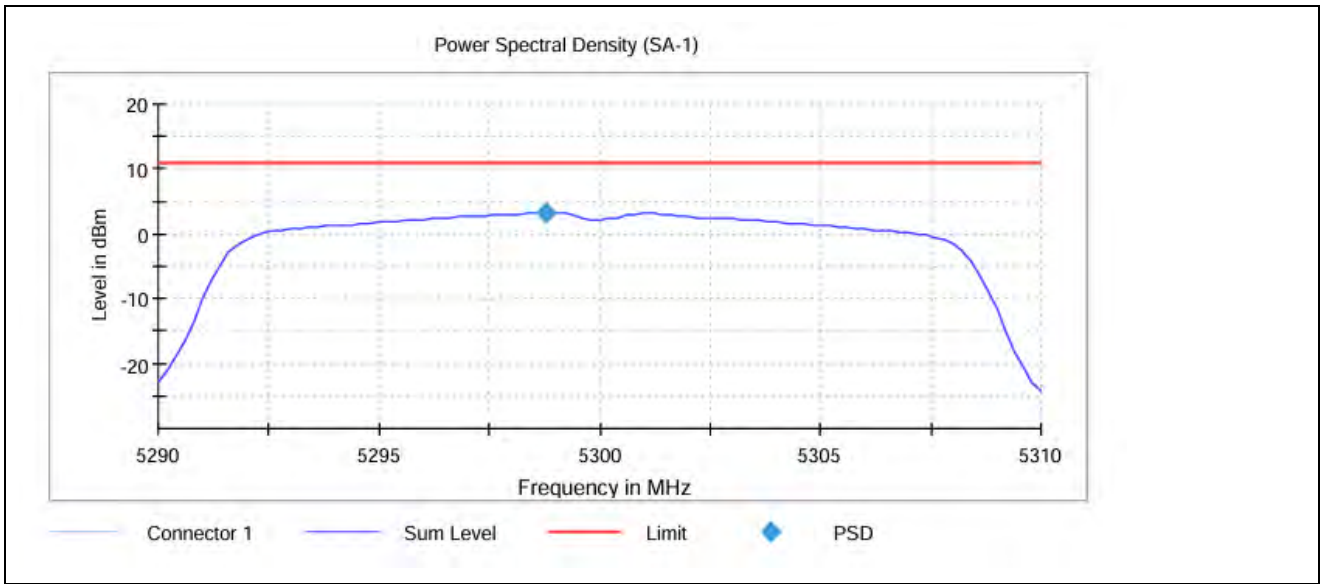

11A_Ant0_5320

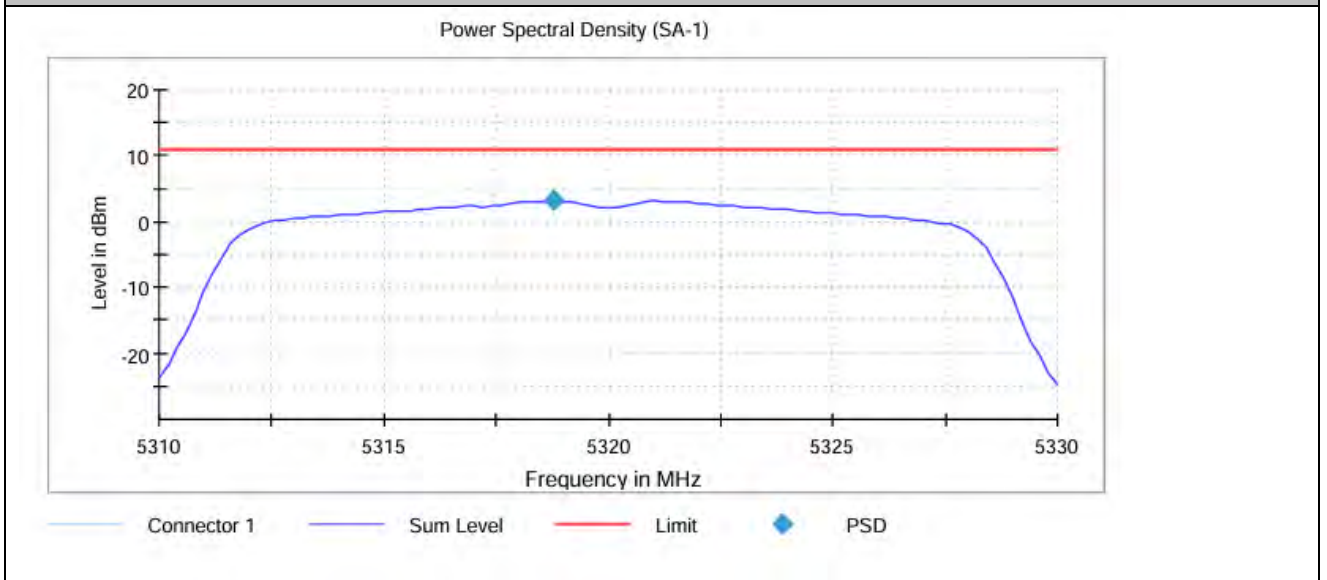

11A_Ant0_5500

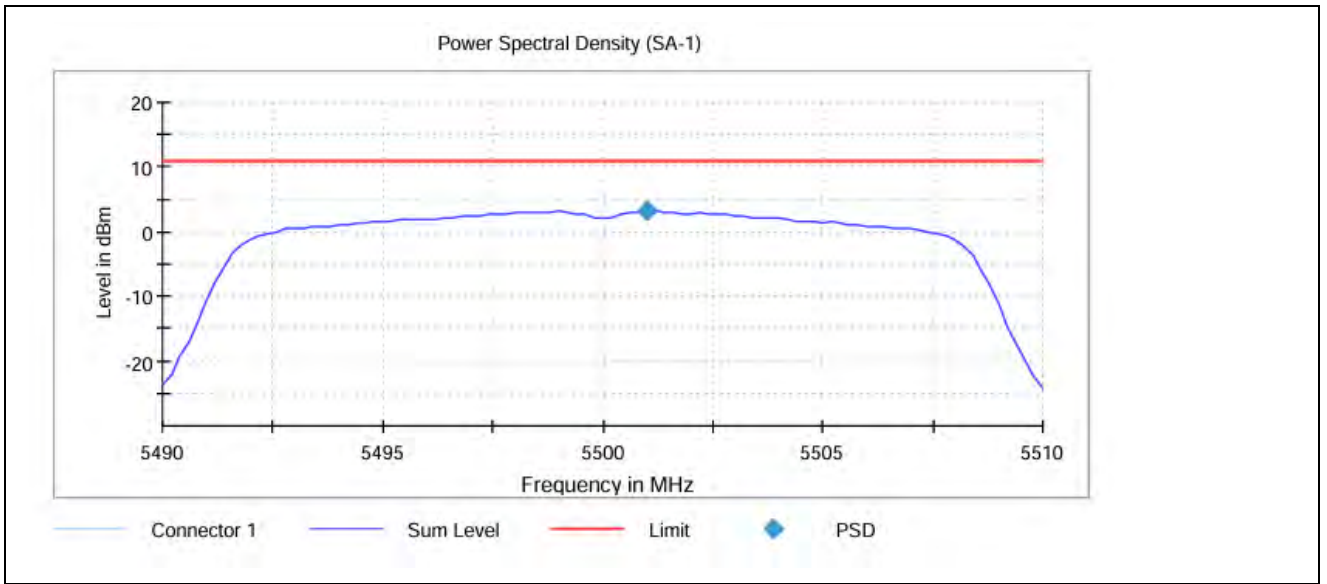

11A_Ant0_5580

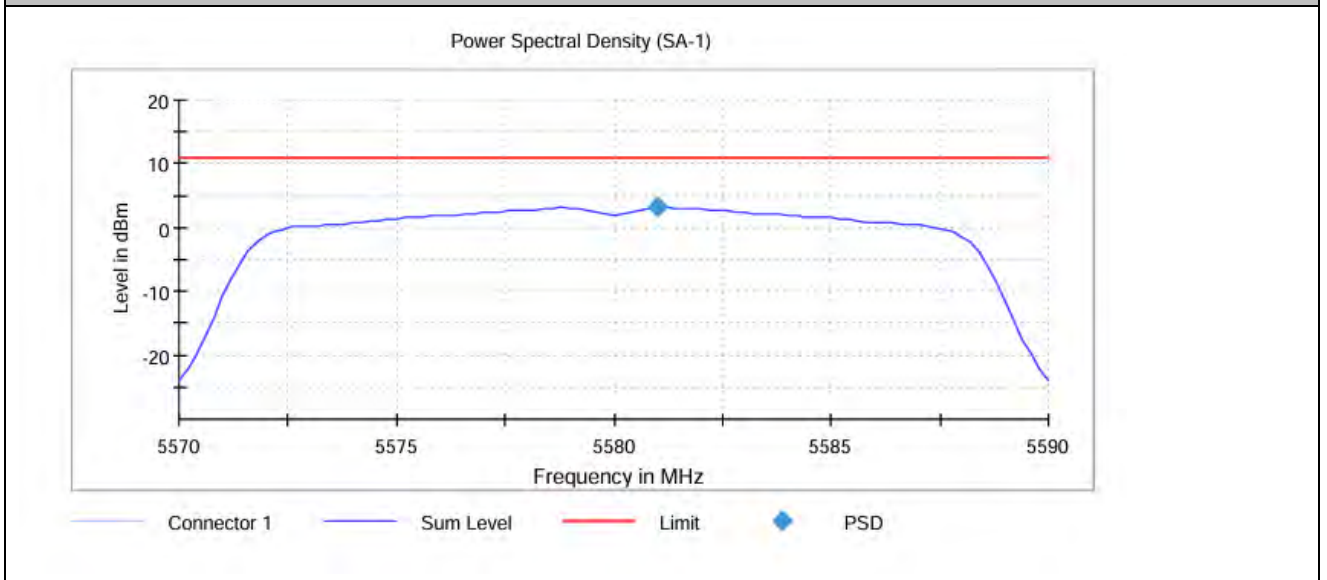

11A_Ant0_5700

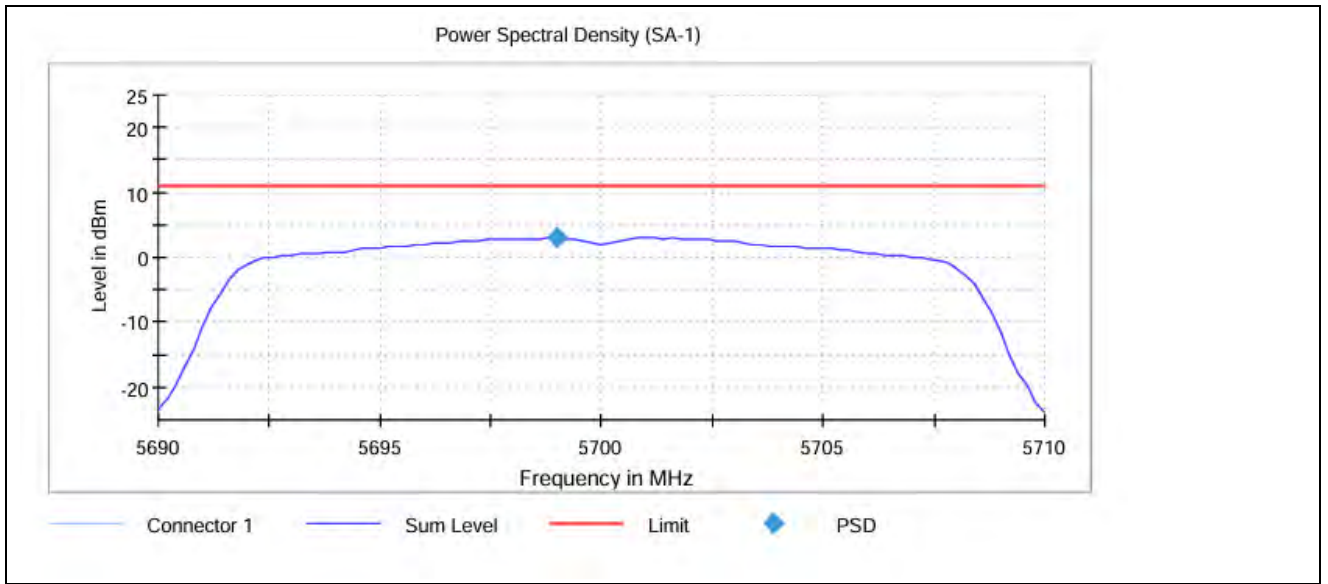

11A_Ant0_5720

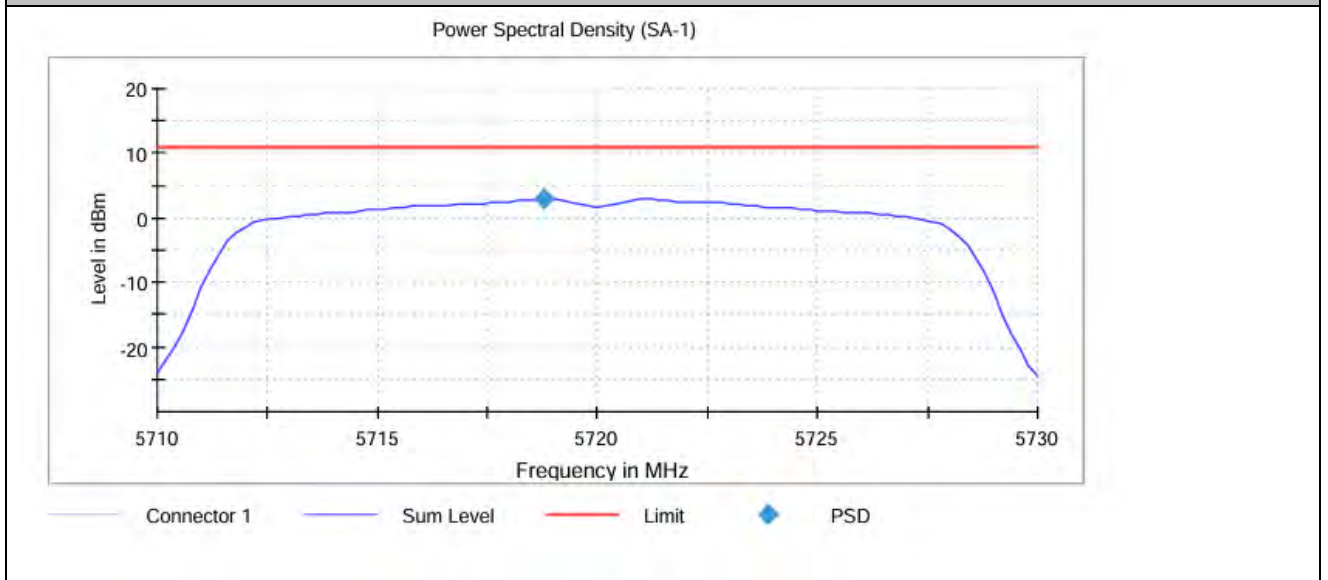

11A_Ant0_5745

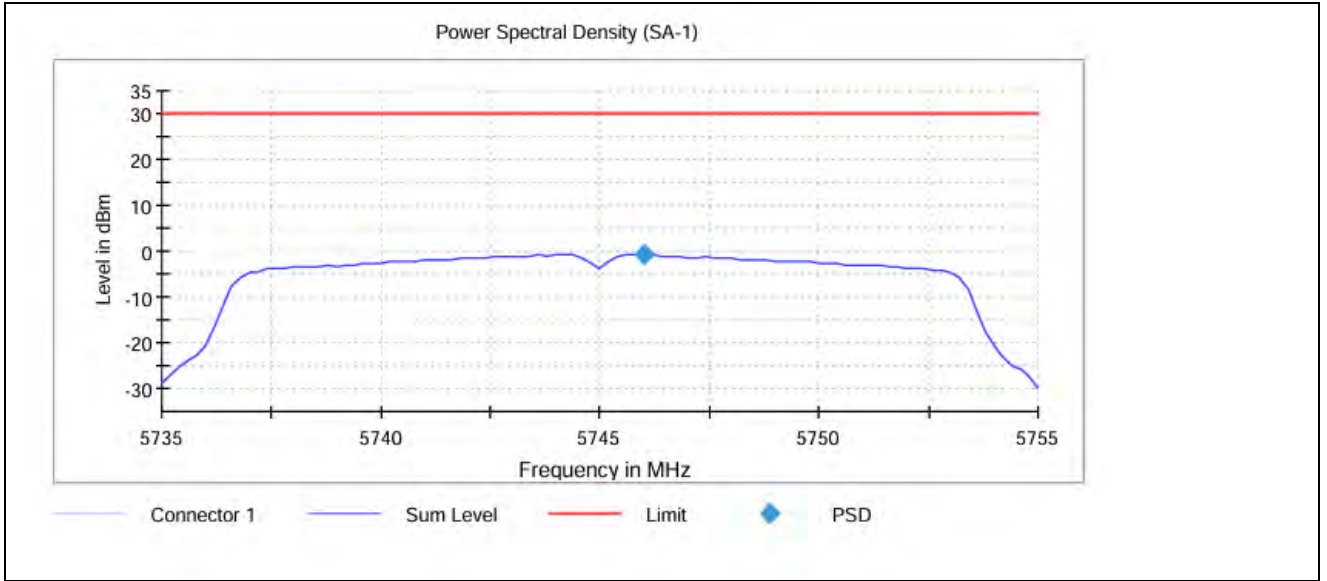

11A_Ant0_5785

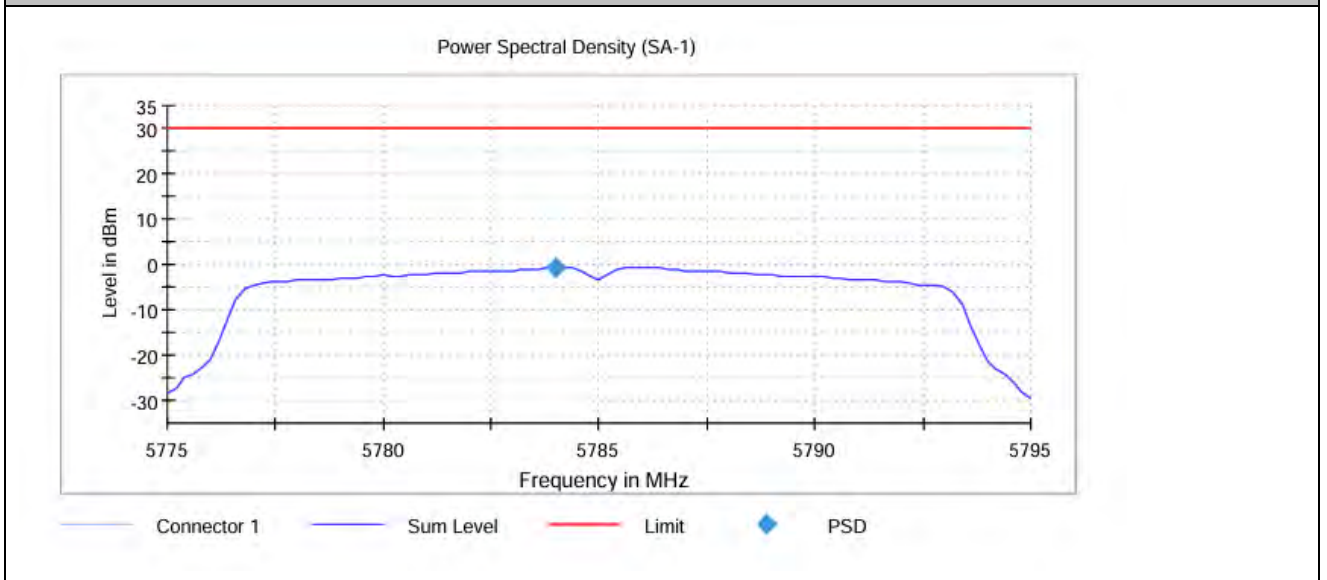

11A_Ant0_5825



BUREAU
VERITAS

Test Report No.: W7L-240618W002RF03

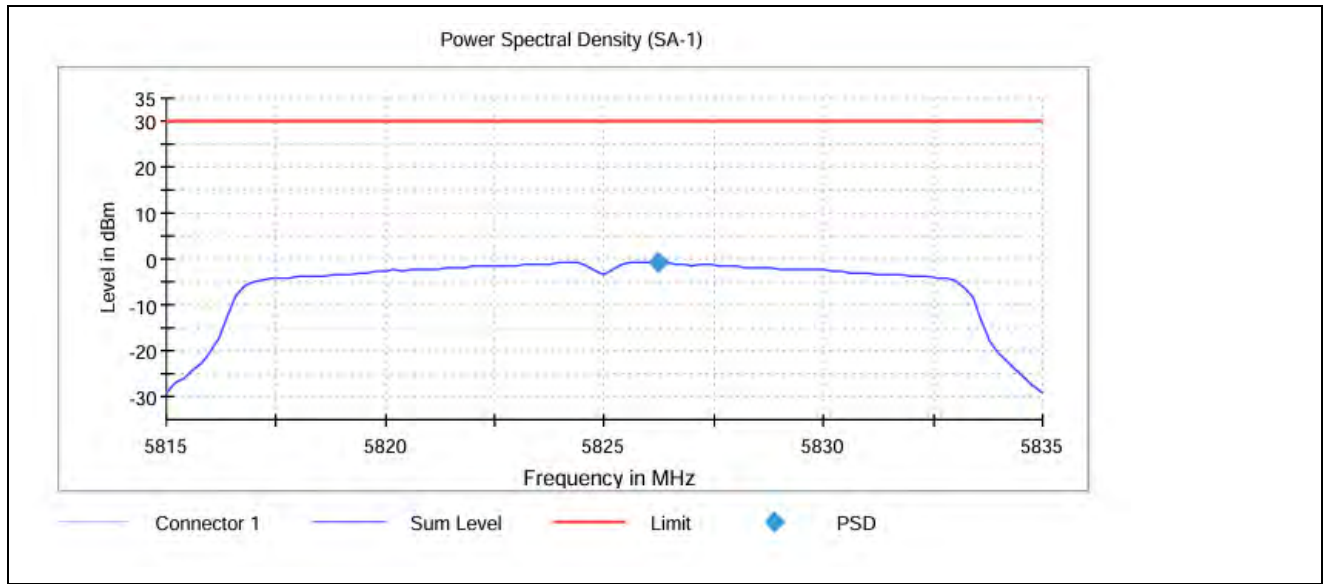

11N20_Ant0_5180

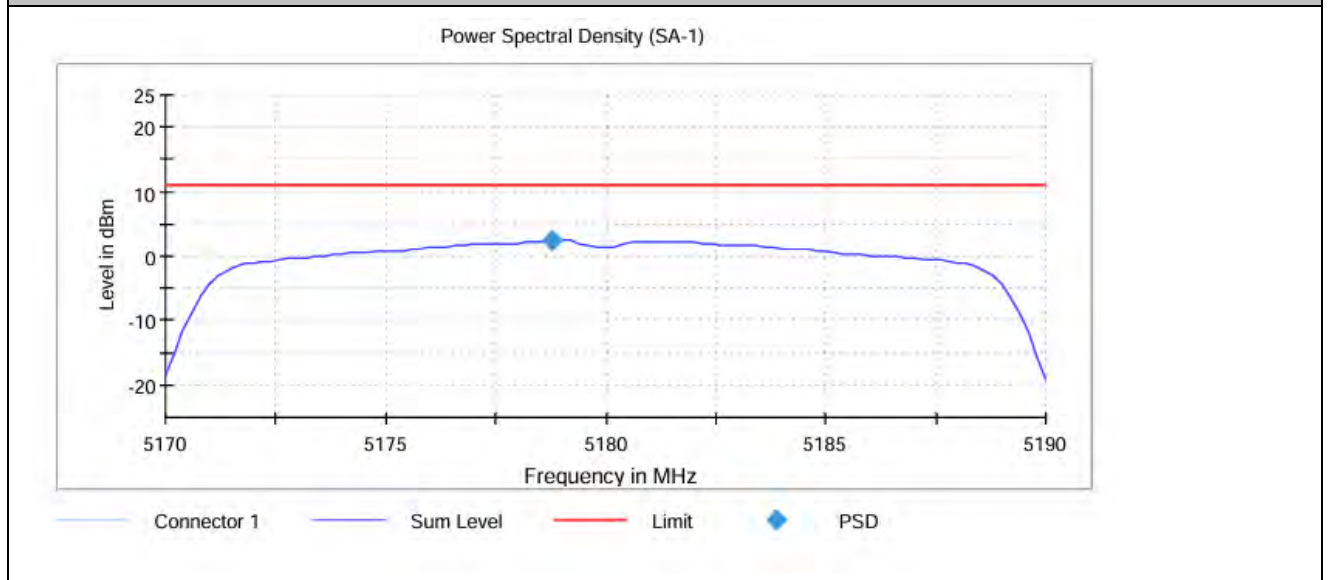

11N20_Ant0_5200

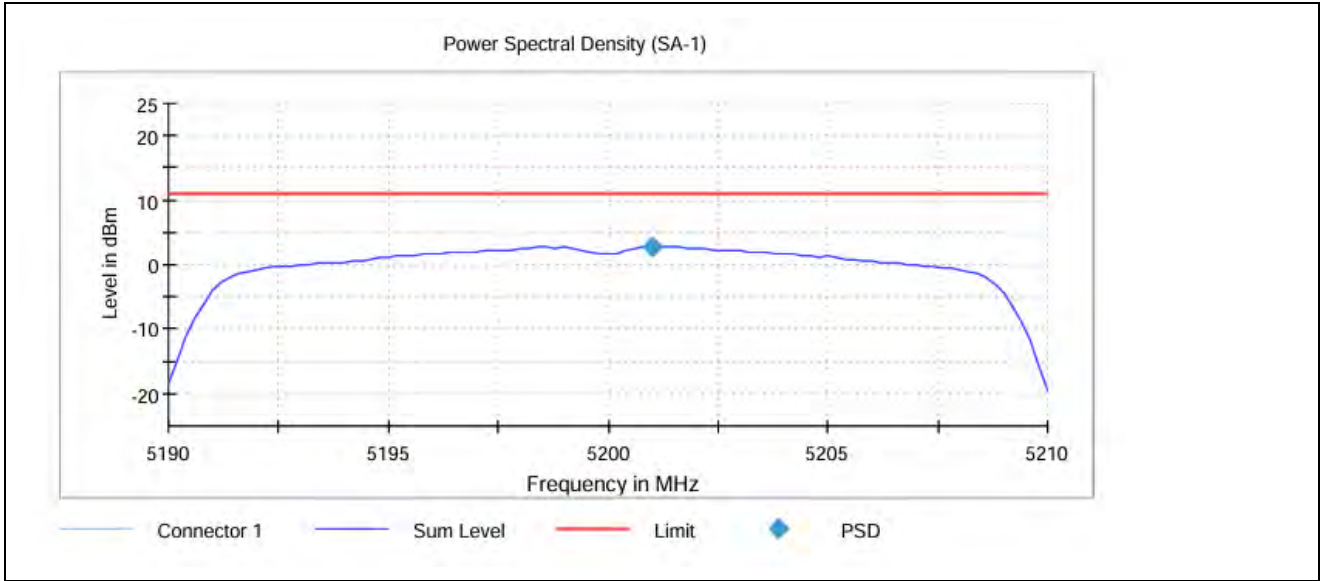

11N20_Ant0_5240

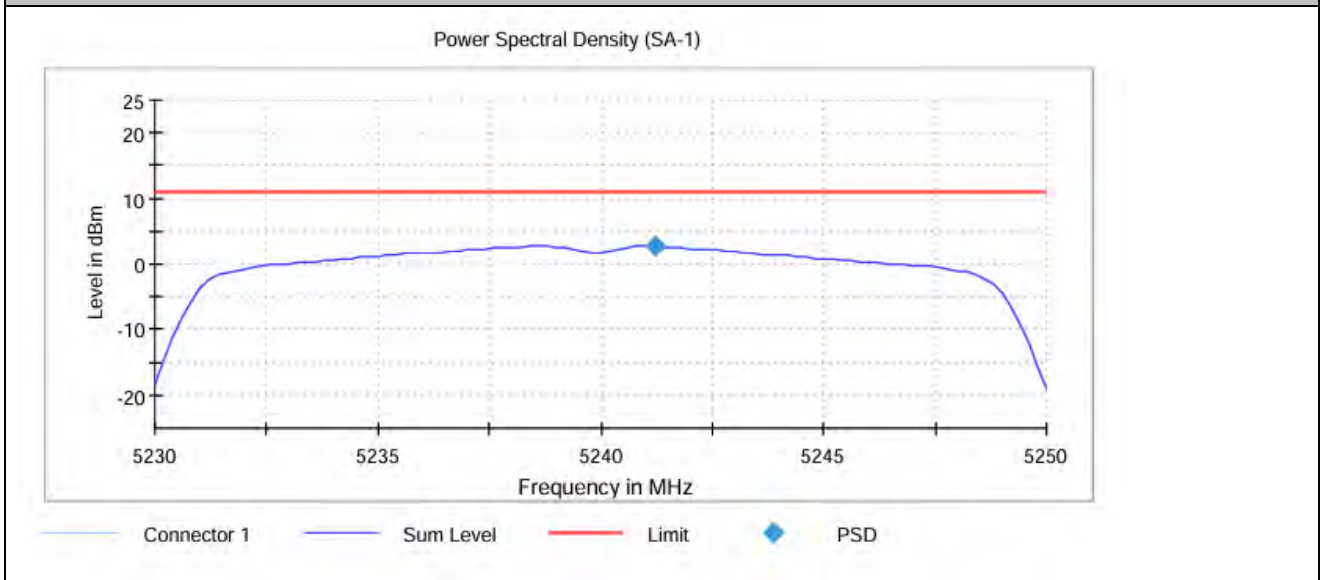

11N20_Ant0_5260

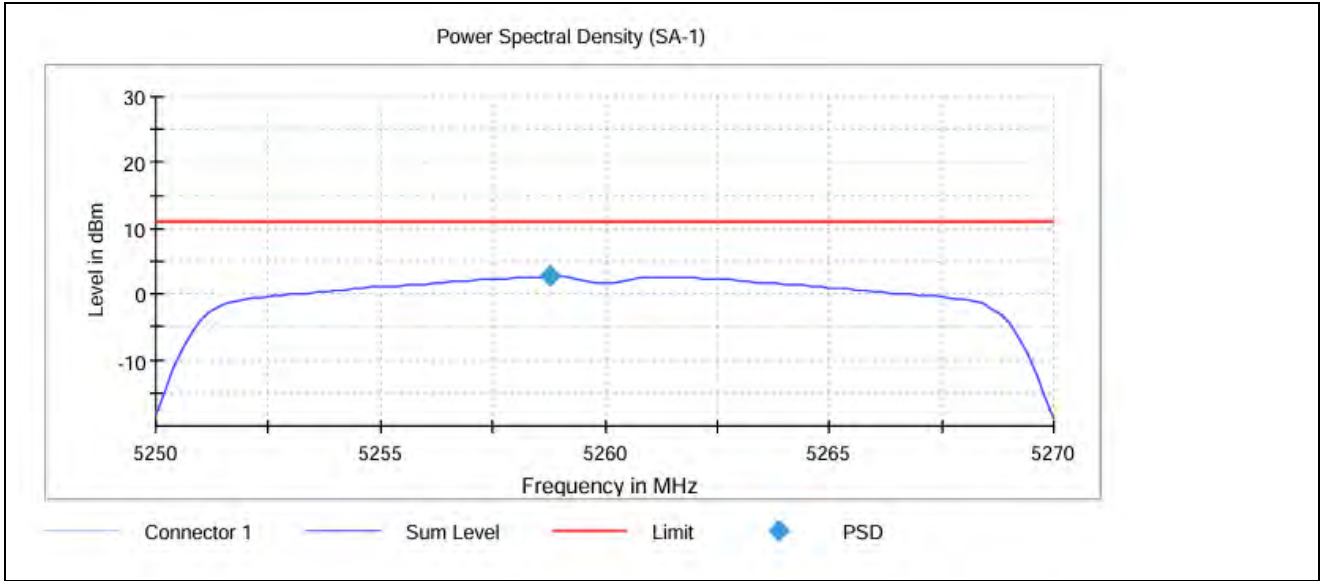

11N20_Ant0_5300

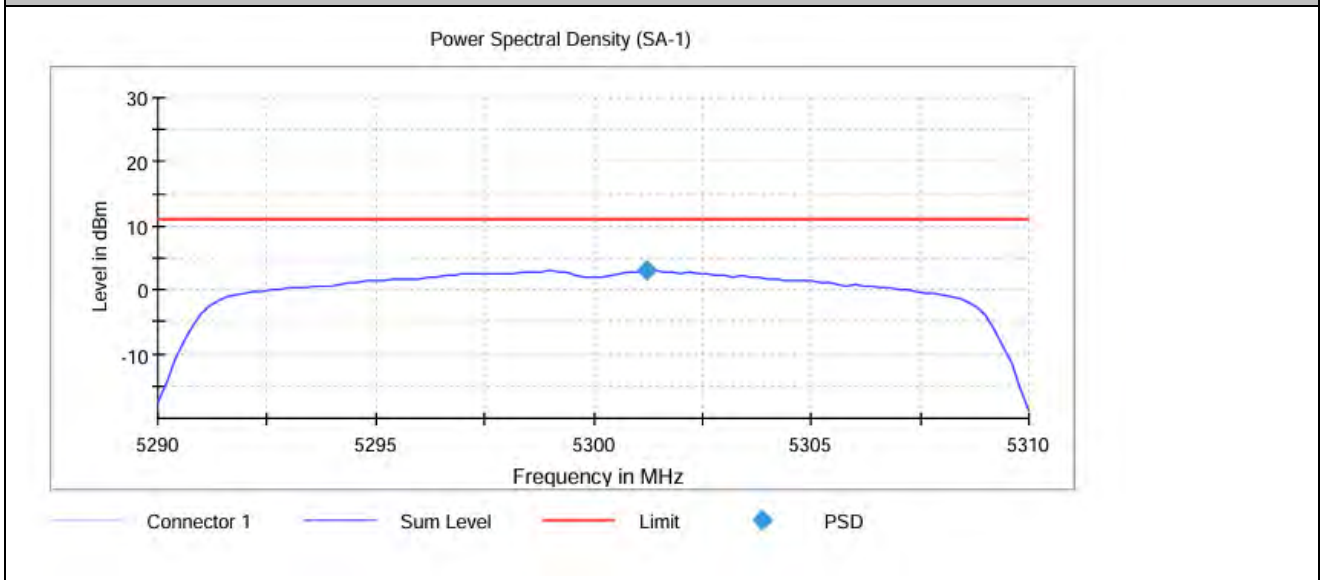

11N20_Ant0_5320

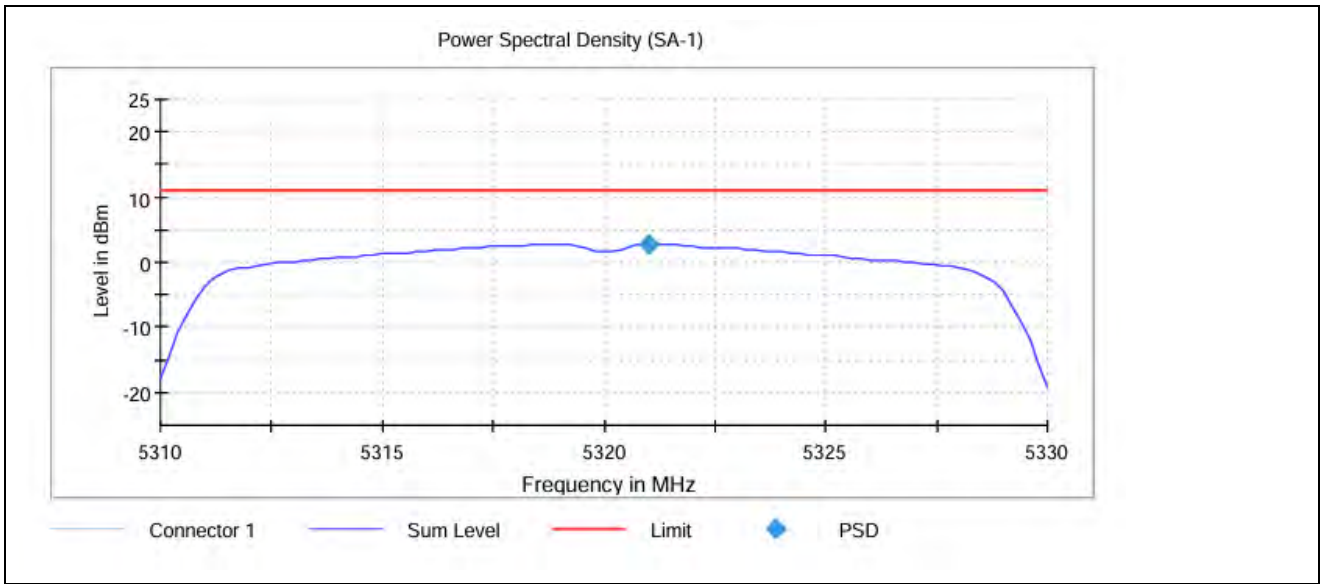

11N20_Ant0_5500

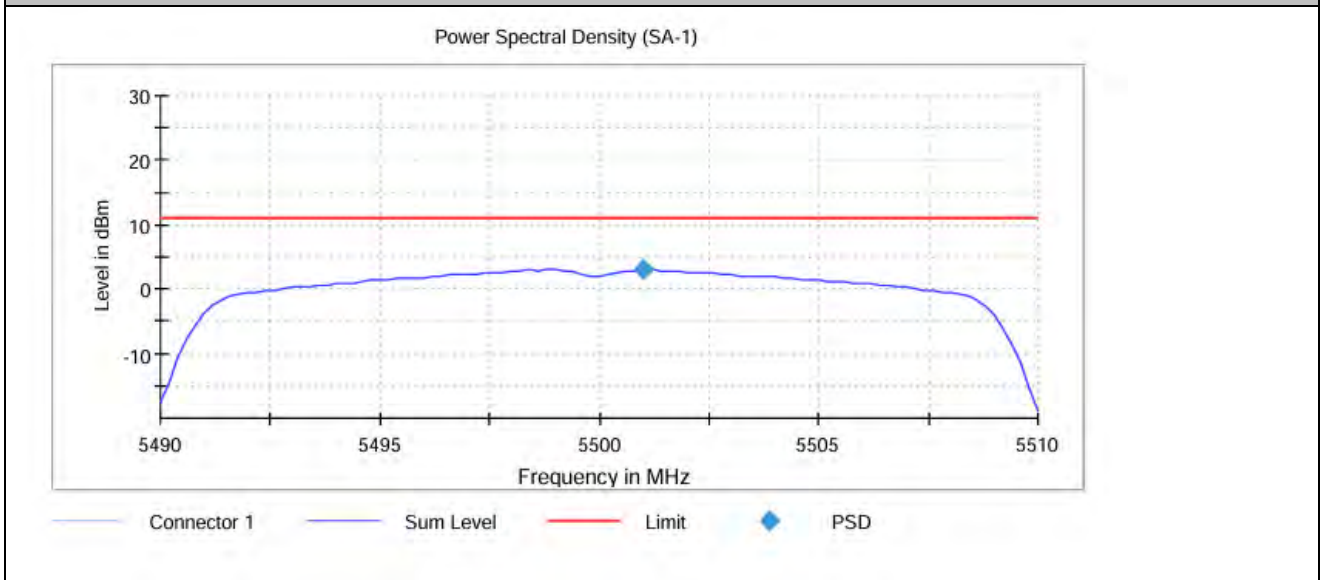

11N20_Ant0_5580

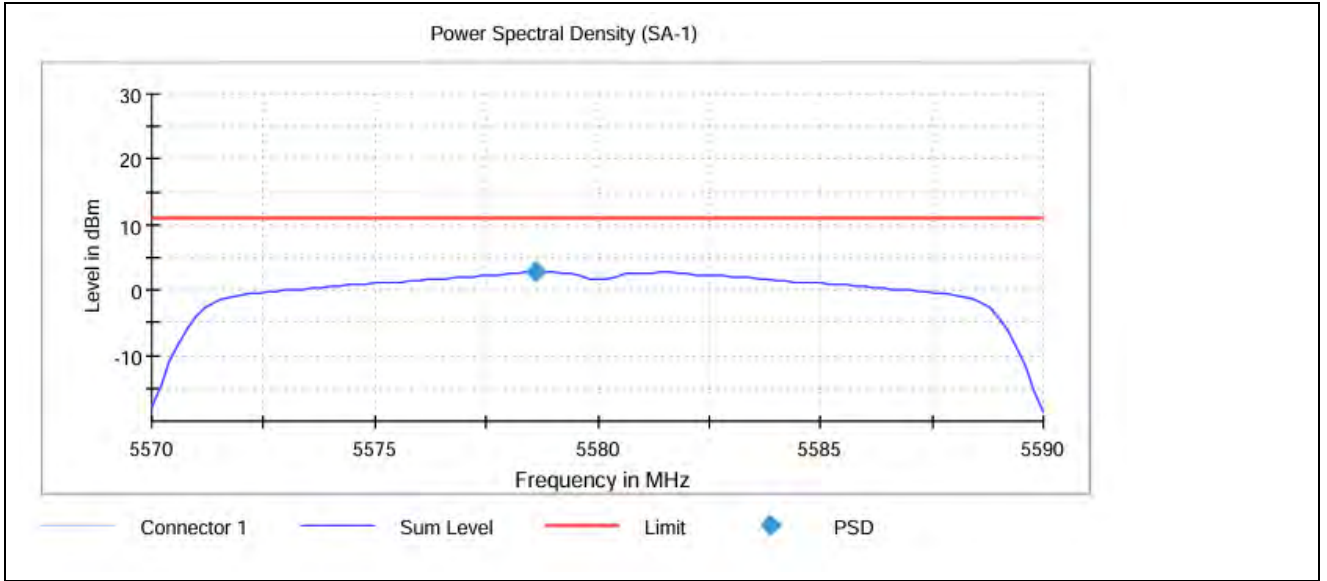

11N20_Ant0_5700

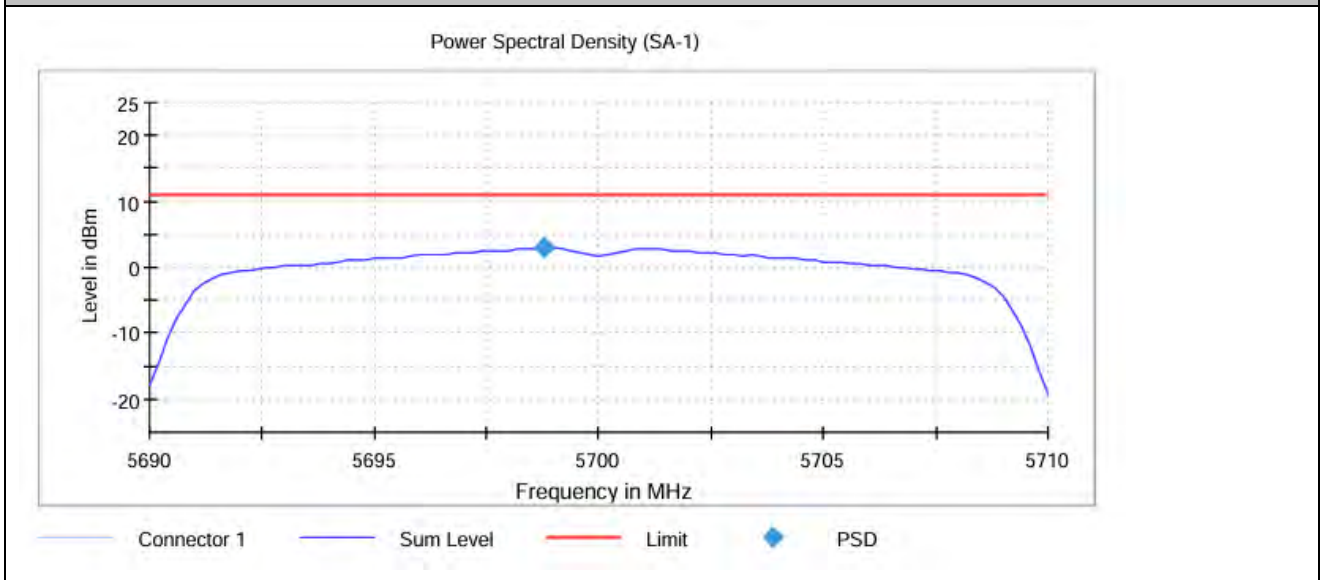

11N20_Ant0_5720

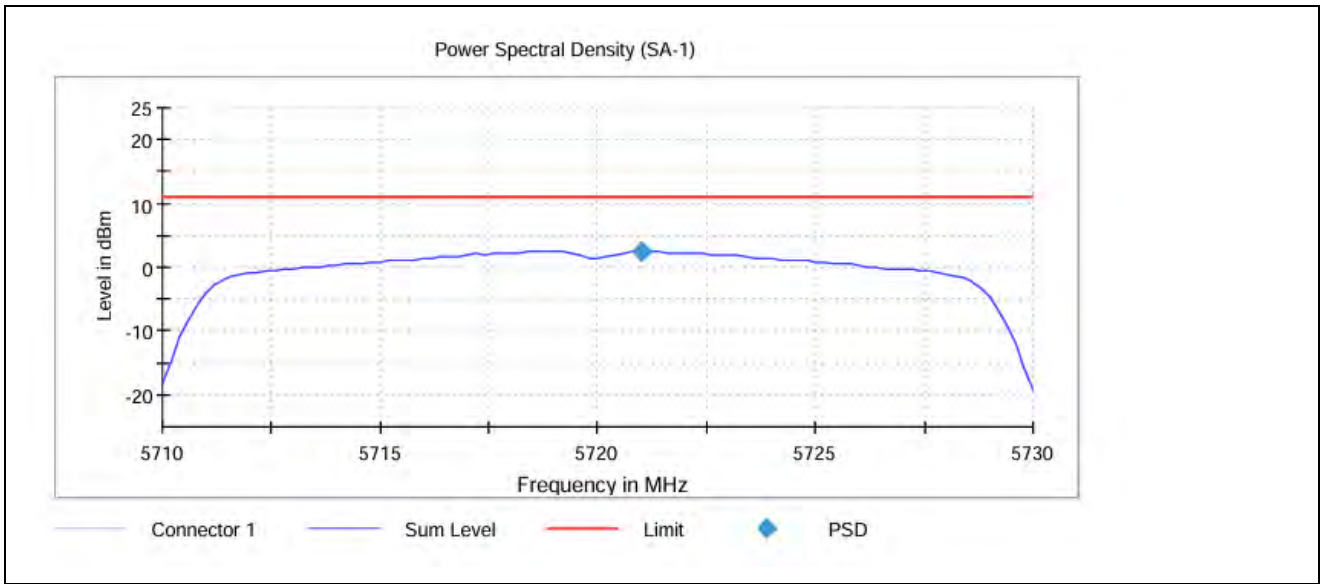

11N20_Ant0_5745

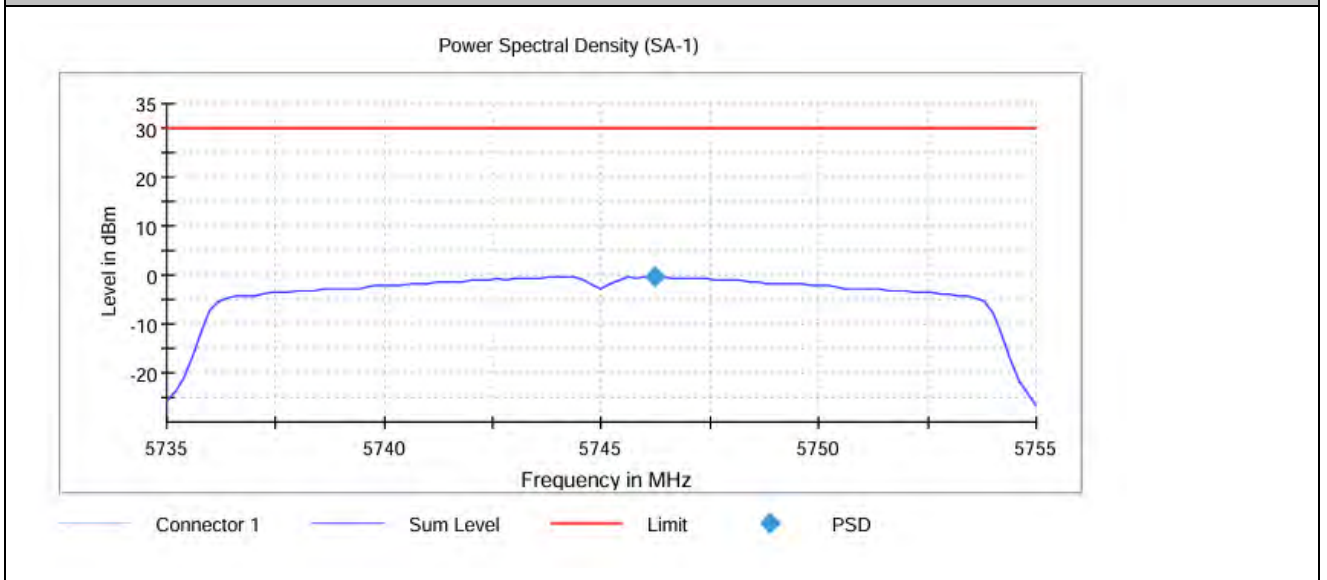

11N20_Ant0_5785

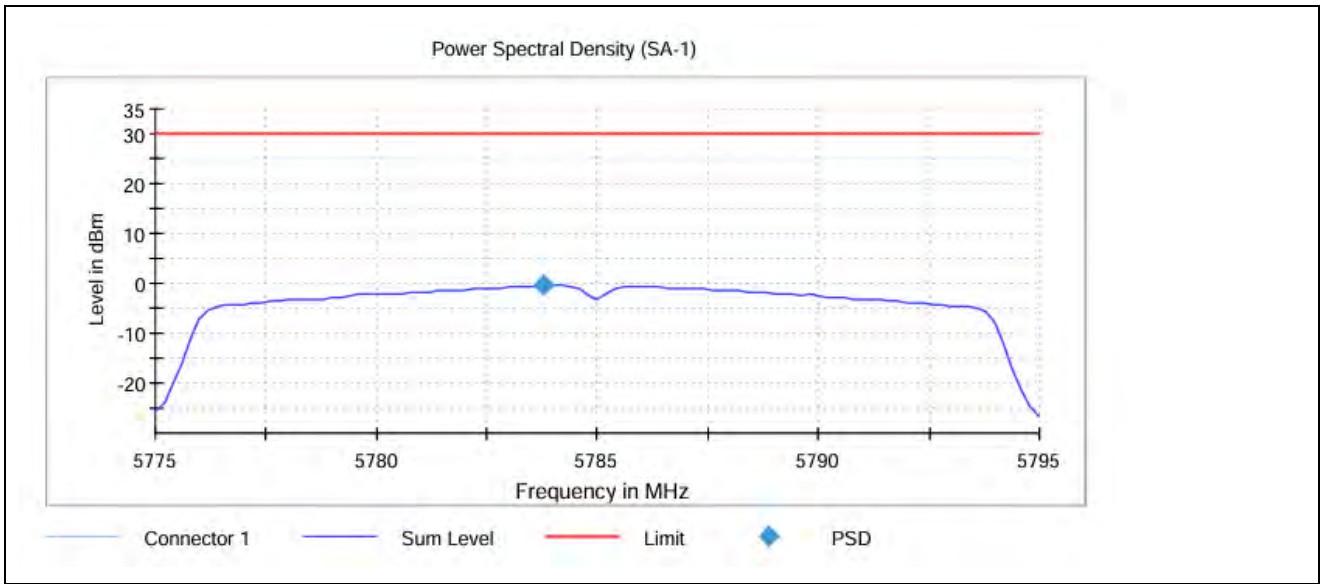

11N20_Ant0_5825

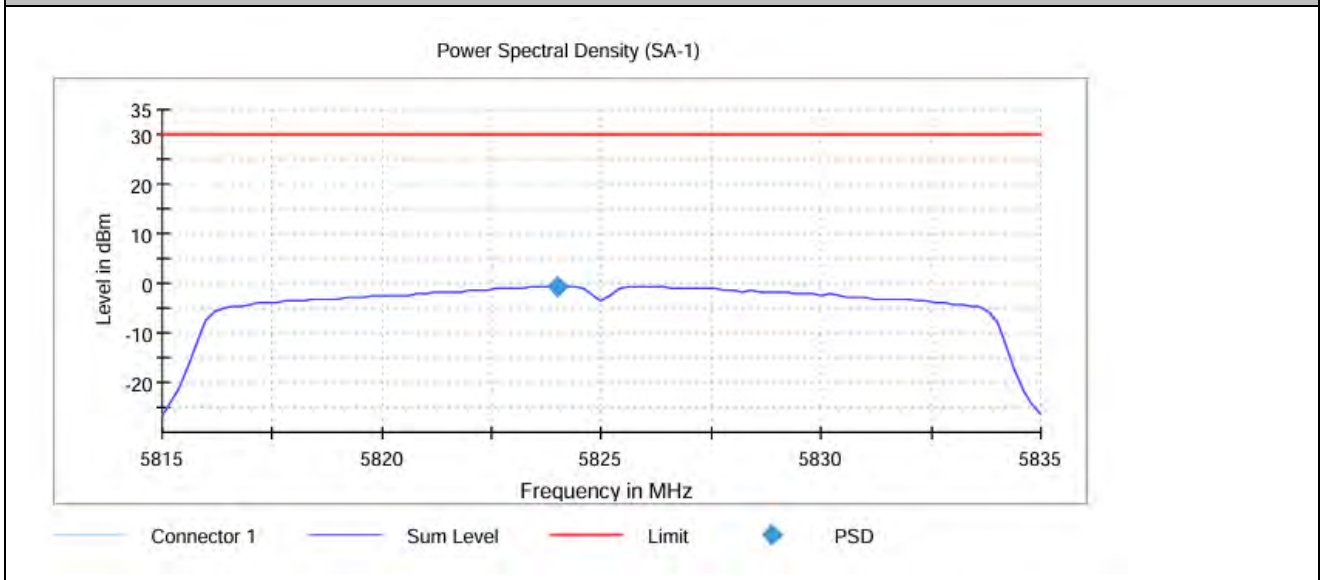

11N40_Ant0_5190



BUREAU
VERITAS

Test Report No.: W7L-240618W002RF03

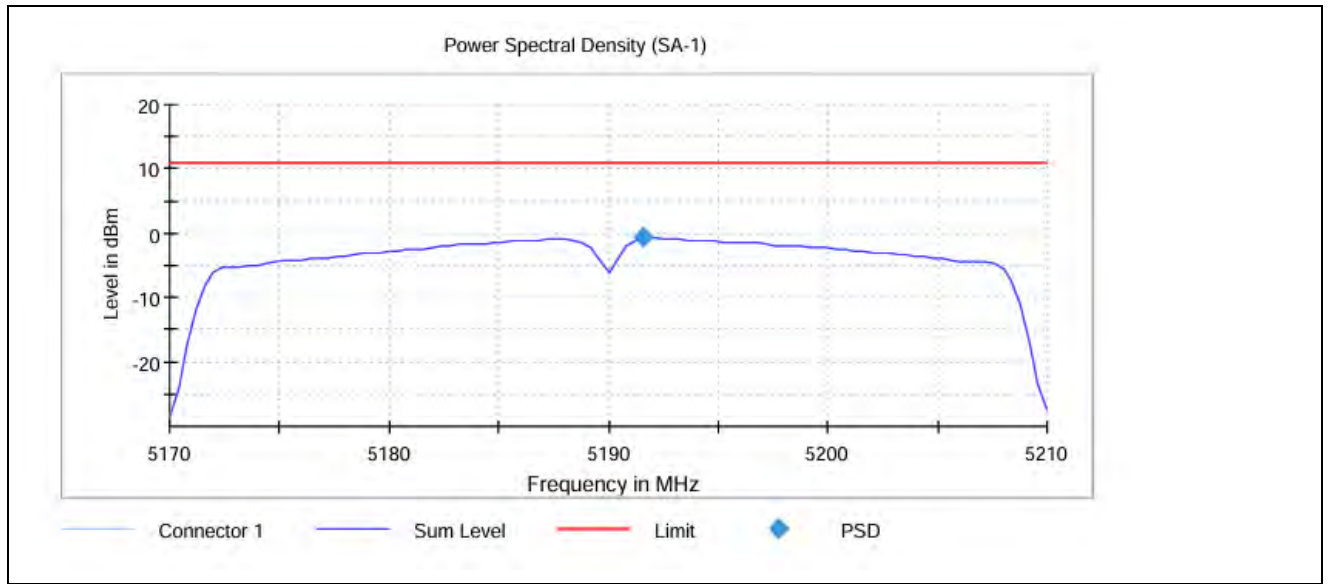

11N40_Ant0_5230

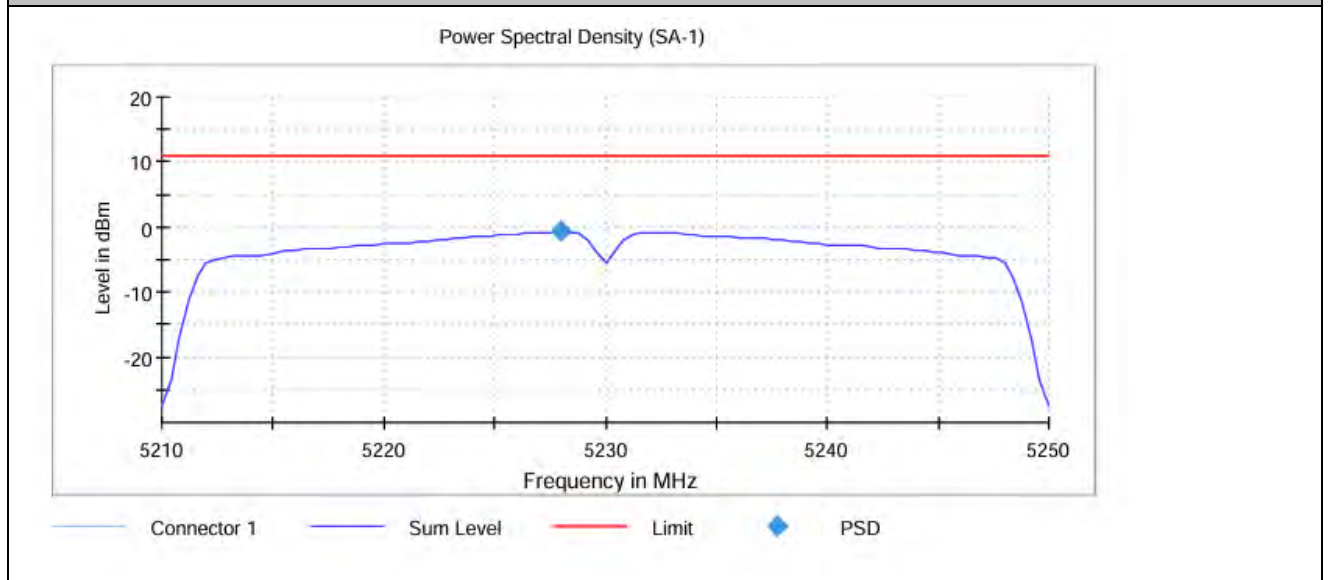

11N40_Ant0_5270



BUREAU
VERITAS

Test Report No.: W7L-240618W002RF03

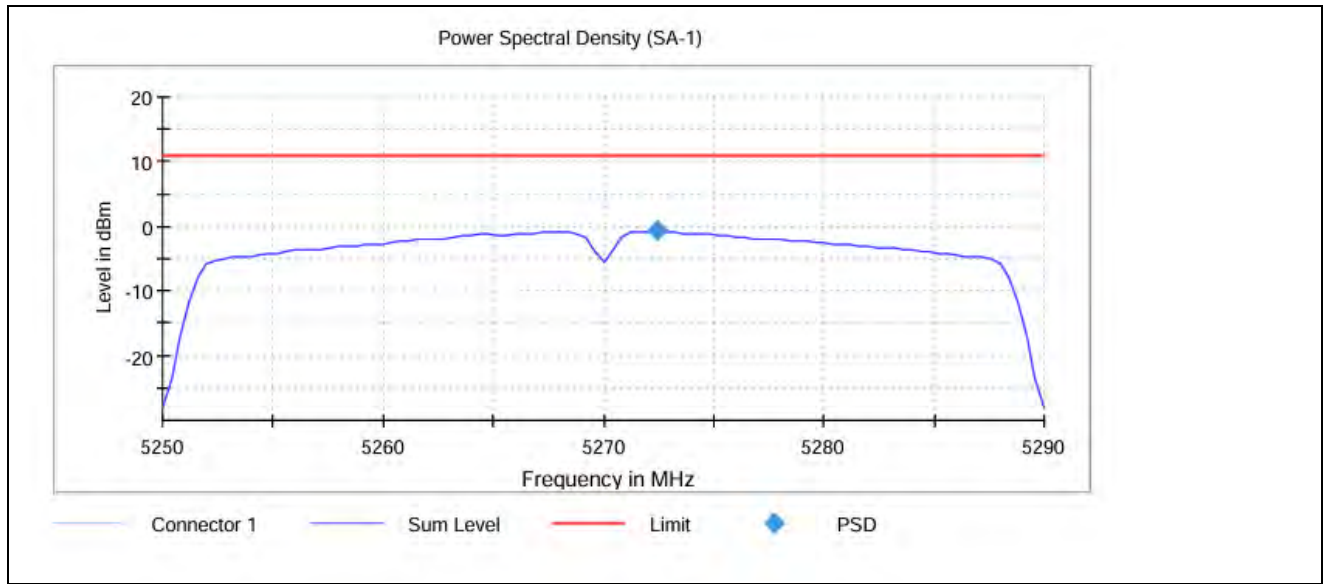

11N40_Ant0_5310

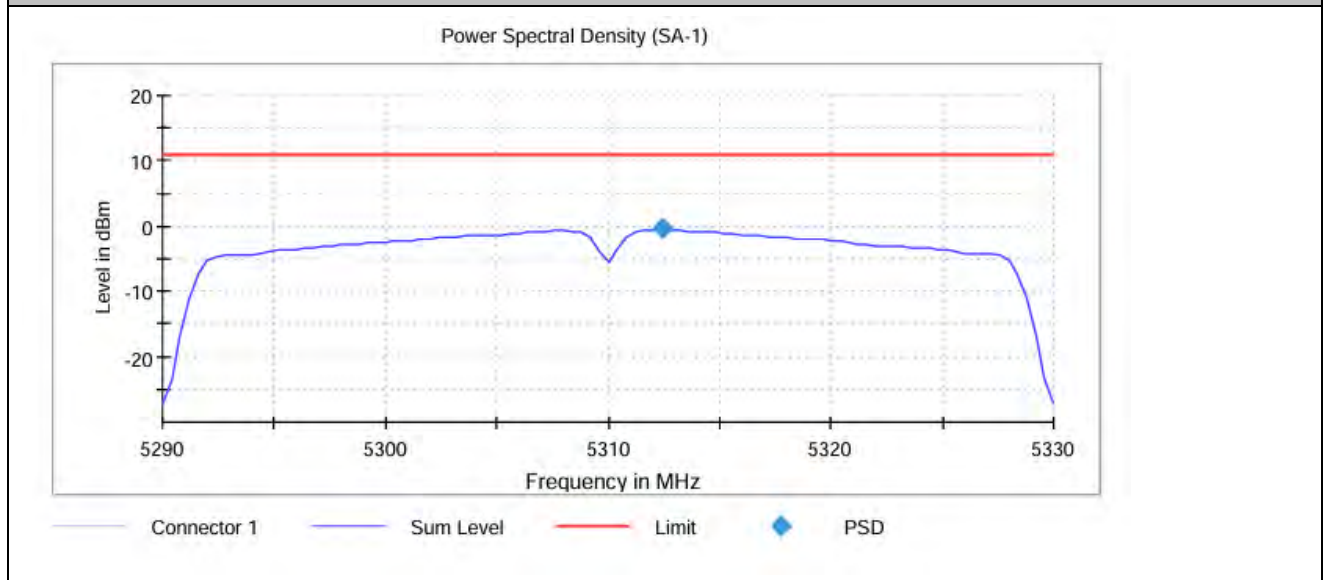

11N40_Ant0_5510



BUREAU
VERITAS

Test Report No.: W7L-240618W002RF03

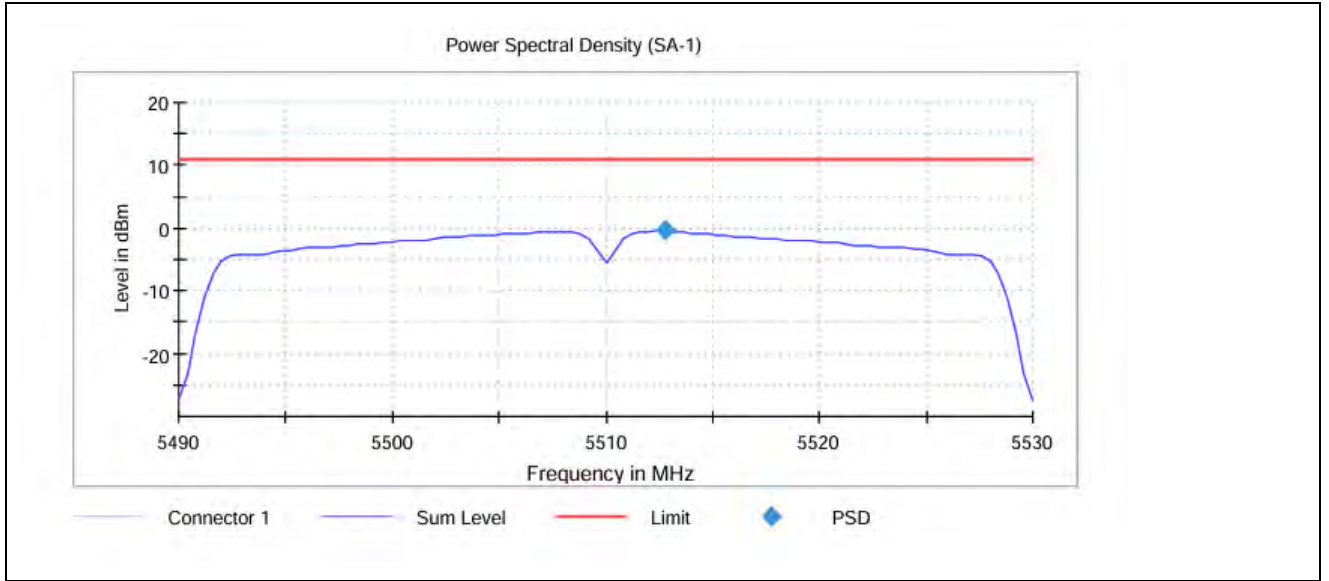

11N40_Ant0_5550

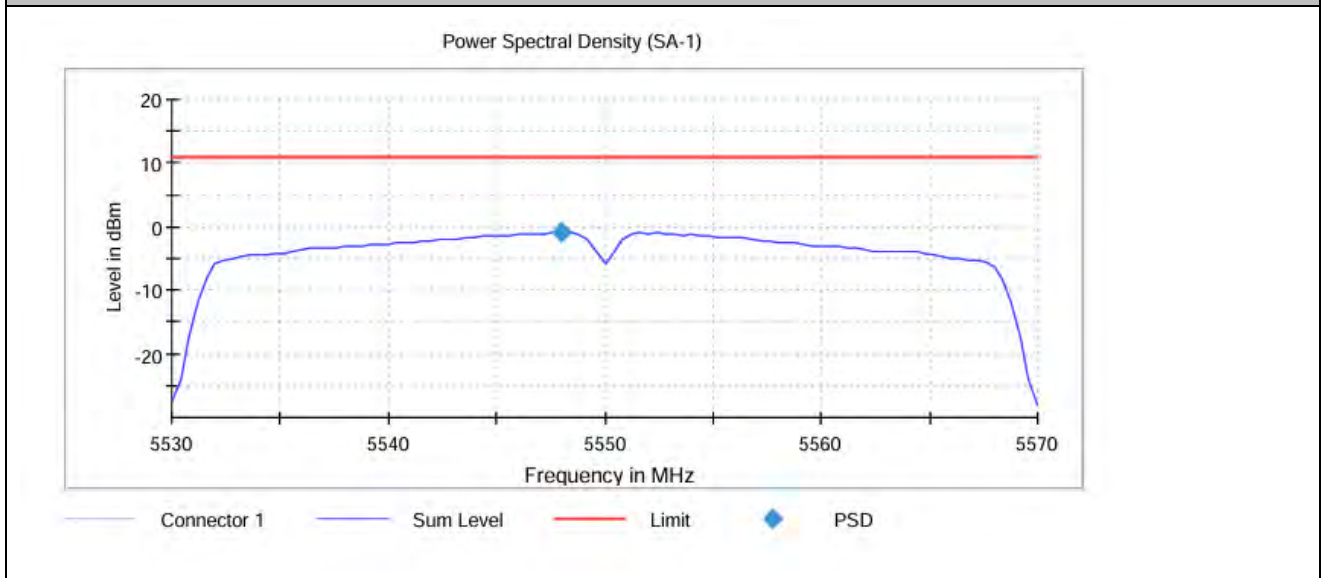

11N40_Ant0_5670



BUREAU
VERITAS

Test Report No.: W7L-240618W002RF03

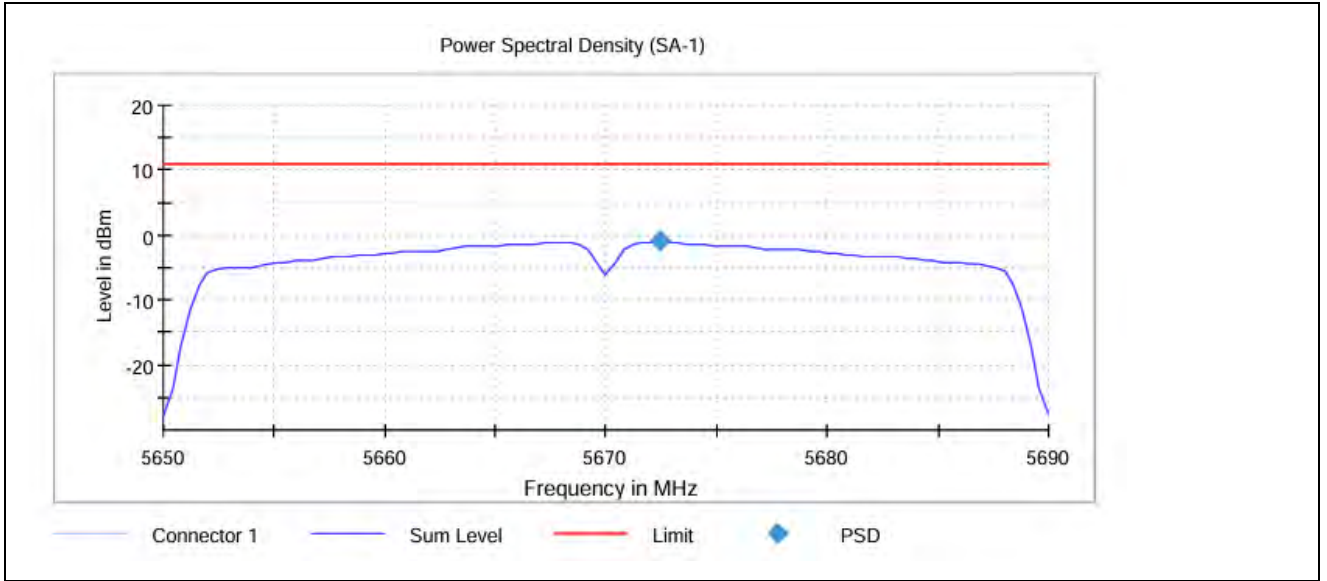

11N40_Ant0_5710

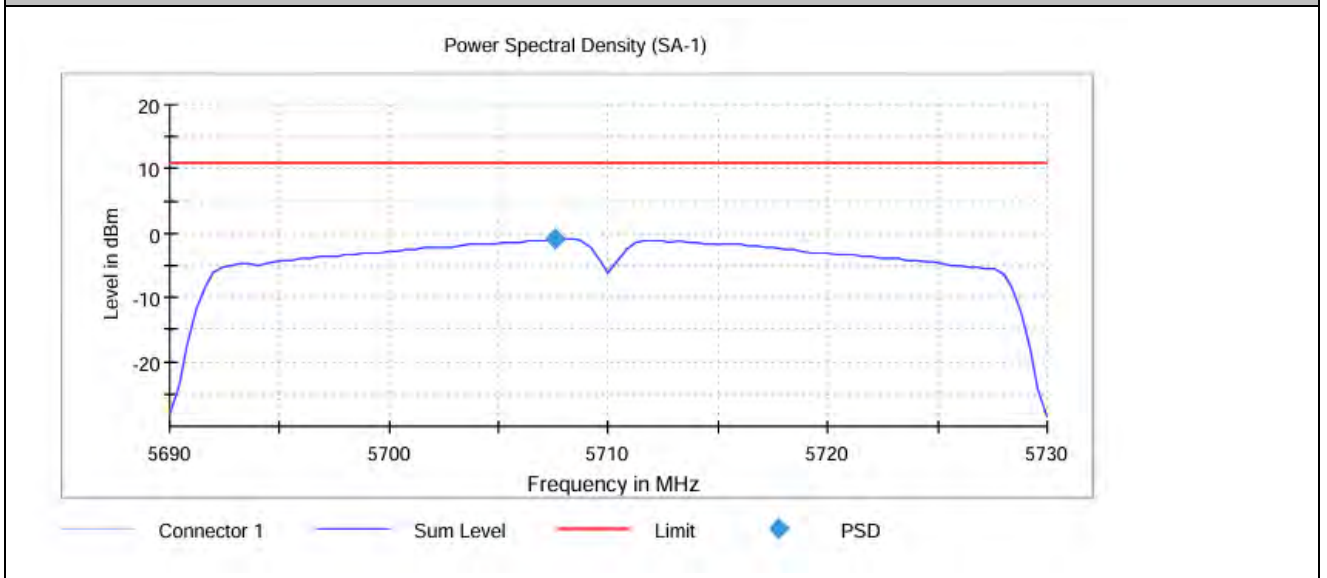

11N40_Ant0_5755



BUREAU
VERITAS

Test Report No.: W7L-240618W002RF03

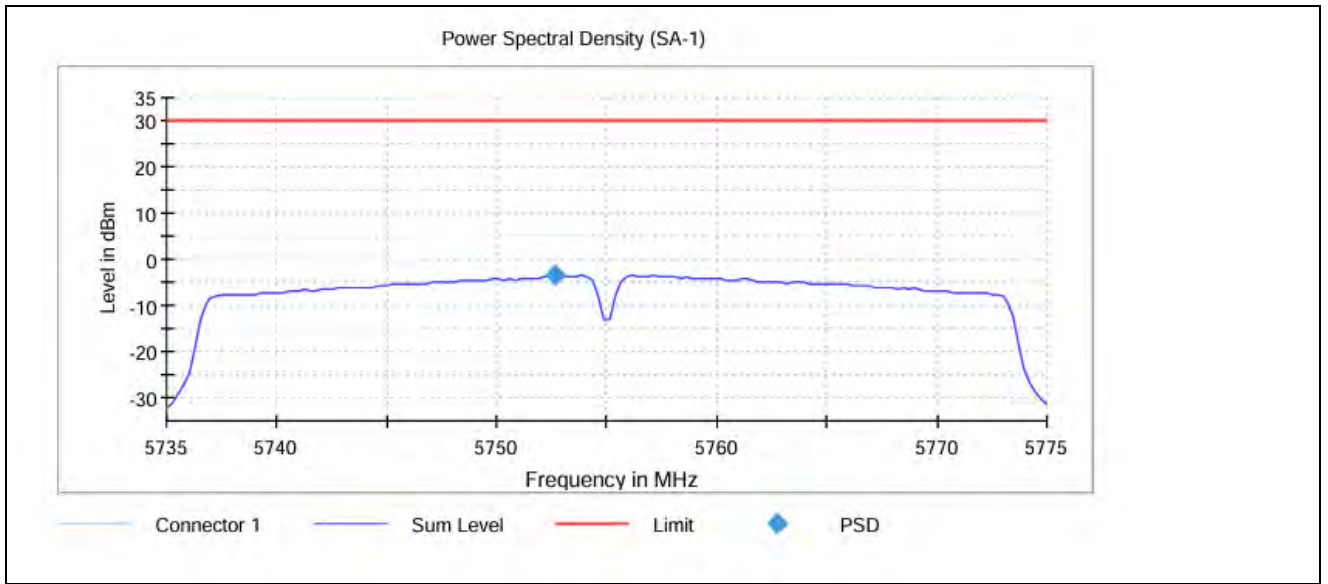

11N40_Ant0_5795

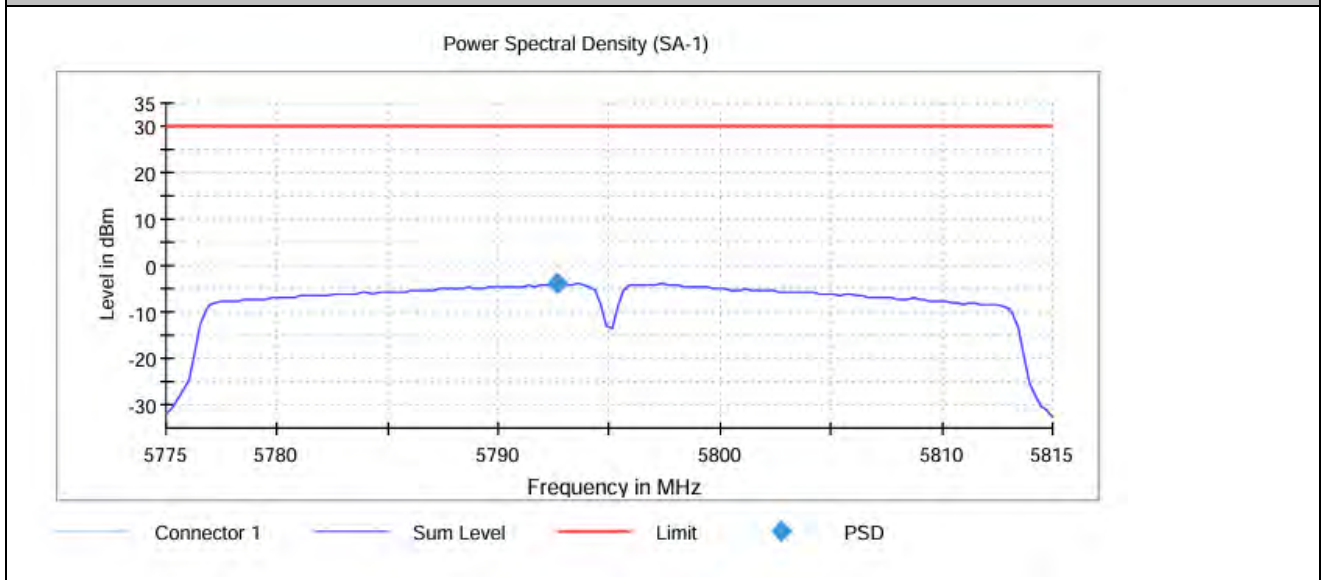

11AC80_Ant0_5210



BUREAU
VERITAS

Test Report No.: W7L-240618W002RF03

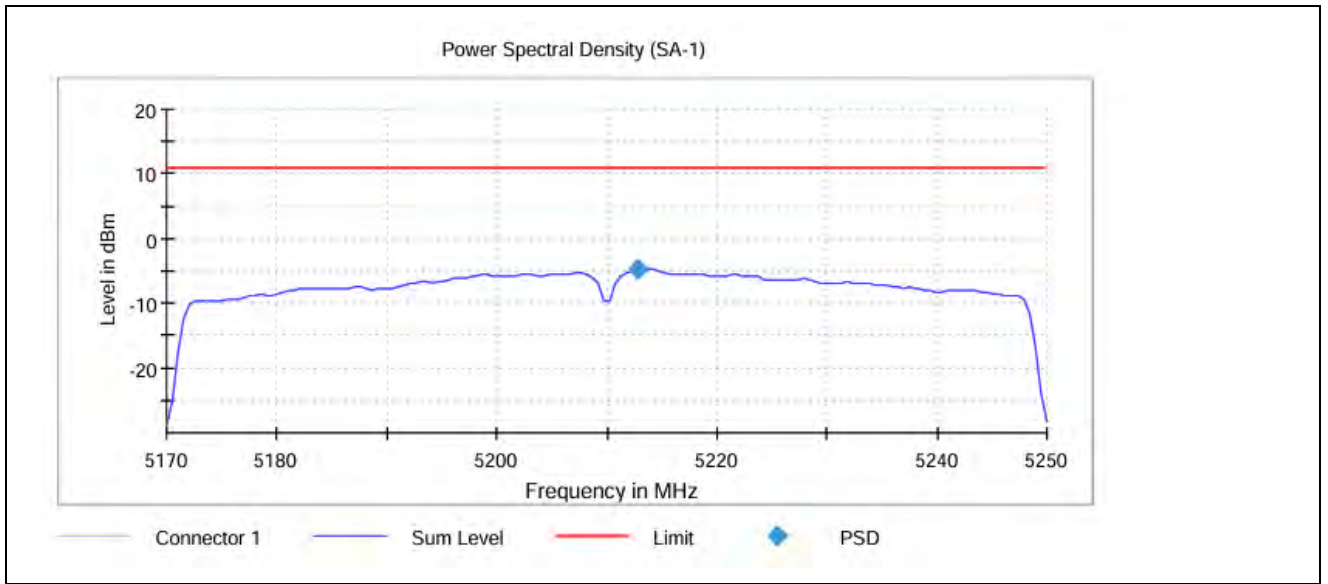

11AC80_Ant0_5290

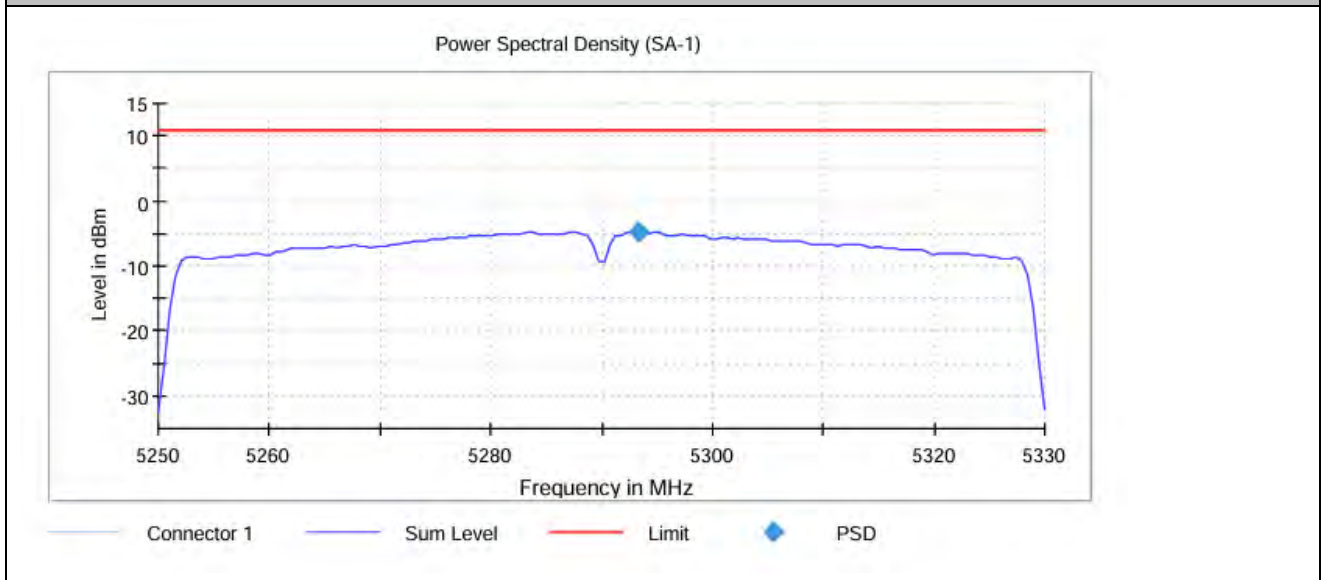

11AC80_Ant0_5530



BUREAU
VERITAS

Test Report No.: W7L-240618W002RF03

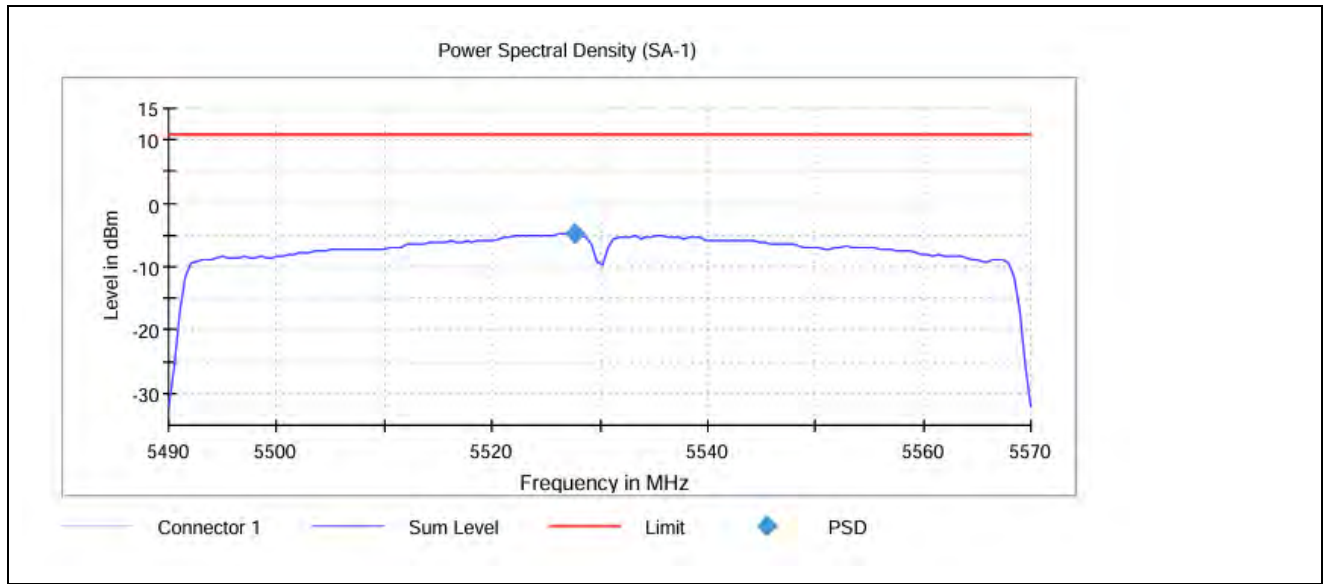

11AC80_Ant0_5610

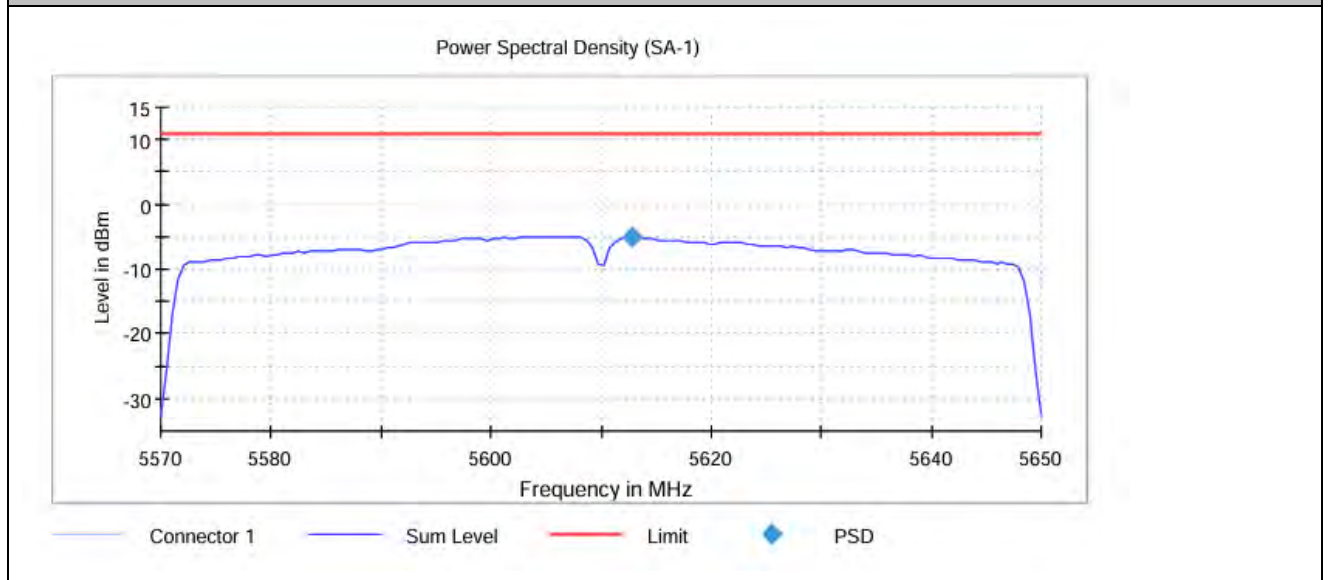

11AC80_Ant0_5690



BUREAU
VERITAS

Test Report No.: W7L-240618W002RF03

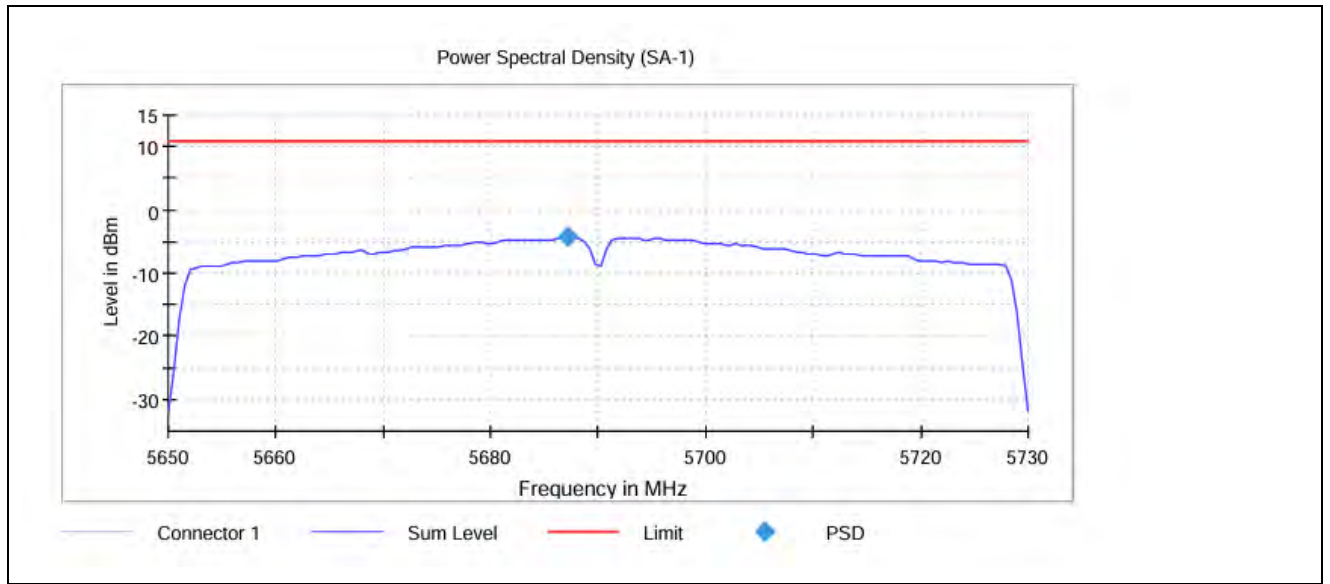

11AC80_Ant0_5775

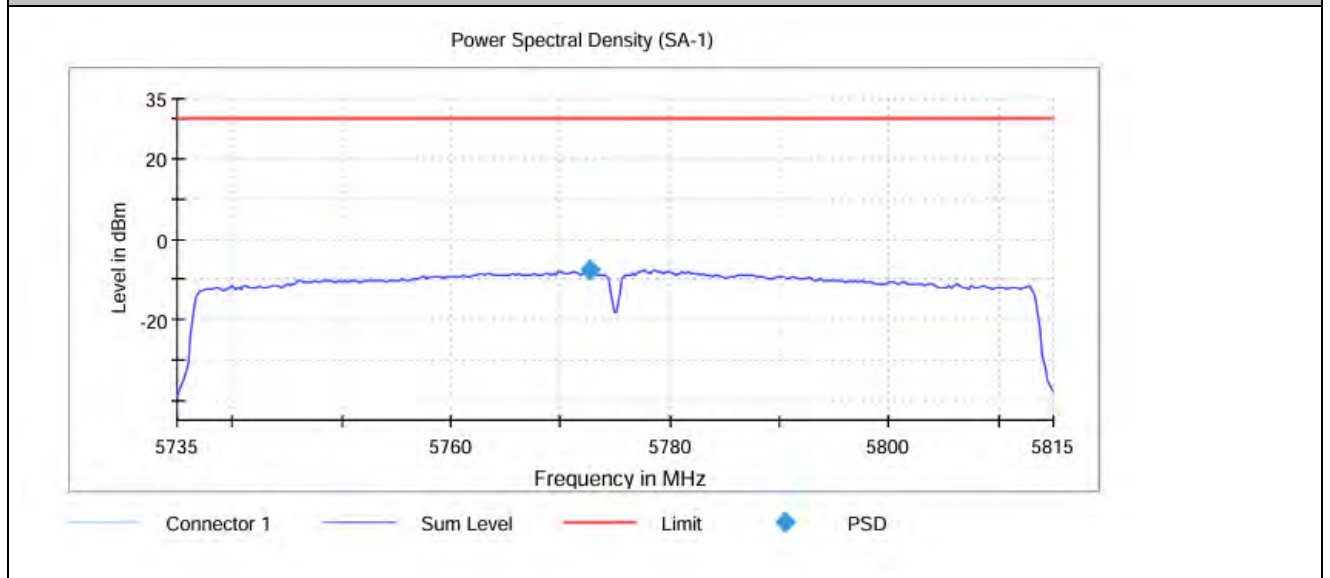

20M

RBW 1.000 MHz

VBW 3.000 MHz

40M

RBW 1.000 MHz

VBW 3.000 MHz

80M

RBW 1.000 MHz

VBW 3.000 MHz

160M

RBW 1.000 MHz



VBW 3.000 MHz

BAND4

20M

RBW 500.000 kHz

VBW 2.000 MHz

40M

RBW 500.000 kHz

VBW 2.000 MHz

80M

RBW 500.000 kHz

VBW 2.000 MHz

---END---