

RF TEST REPORT

Applicant	Xiaomi Communications Co., Ltd.
FCC ID	2AFZZPCA6G
Product	Mobile Phone
Brand	POCO
Model	2312FPCA6G
Report No.	R2309A0988-R3
Issue Date	October 26, 2023

TA Technology (Shanghai) Co., Ltd. tested the above equipment in accordance with the requirements in **FCC CFR47 Part 2 (2022)/ FCC CFR47 Part 27C (2022)**. The test results show that the equipment tested is capable of demonstrating compliance with the requirements as documented in this report.

Prepared by: Xu Ying

Approved by: Xu Kai

TA Technology (Shanghai) Co., Ltd.

Building 3, No.145, Jintang Rd, Pudong Shanghai, P.R.China

TEL: +86-021-50791141/2/3

FAX: +86-021-50791141/2/3-8000

TABLE OF CONTENT

1	Test Laboratory	5
1.1	Notes of the Test Report	5
1.2.	Test facility	5
1.3	Testing Location	5
2	General Description of Equipment under Test	6
2.1	Applicant and Manufacturer Information	6
2.2	General information	6
3	Applied Standards	8
4	Test Configuration	9
5	Test Case	12
5.1	RF Power Output and Effective Isotropic Radiated Power	12
5.2	Occupied Bandwidth	14
5.3	Band Edge Compliance	15
5.4	Peak-to-Average Power Ratio (PAPR)	18
5.5	Frequency Stability	19
5.6	Spurious Emissions at Antenna Terminals	20
5.7	Radiated Spurious Emission	22
6	Test Results	26
6.1	RF Power Output and Effective Isotropic Radiated Power	26
6.2	Occupied Bandwidth	122
6.3	Band Edge Compliance	179
6.4	Peak-to-Average Power Ratio (PAPR)	244
6.5	Frequency Stability	253
6.6	Spurious Emissions at Antenna Terminals	267
6.7	Radiated Spurious Emission	284
7	Main Test Instruments	304
	ANNEX A: The EUT Appearance	305
	ANNEX B: Test Setup Photos	306
	ANNEX C: Product Change Description	307

Summary of Measurement Results

Number	Test Case	Clause in FCC rules	Verdict
1	RF Power Output and Effective Isotropic Radiated Power	2.1046 /27.50(d)(4) /27.50(b)(10) /27.50(c)(10) /27.50(h)(2)	PASS
2	Occupied Bandwidth	2.1049	PASS
3	Band Edge Compliance	27.53(h) /27.53(g) /27.53(f) /27.53(c) /27.53(m)	PASS
4	Peak-to-Average Power Ratio	27.50(d)/KDB971168 D01(5.7)	PASS
5	Frequency Stability	2.1055 / 27.54	PASS
6	Spurious Emissions at Antenna Terminals	2.1051 /27.53(h) /27.53(g) /27.53(f) /27.53(c) /27.53(m)	PASS
7	Radiated Spurious Emission	2.1053 /27.53(h) /27.53(g) /27.53(f) /27.53(c) /27.53(m)	PASS

Date of Testing: September 23, 2023 ~ October 12, 2023

Date of Sample Received: September 20, 2023

Note: PASS: The EUT complies with the essential requirements in the standard.

FAIL: The EUT does not comply with the essential requirements in the standard.

All indications of Pass/Fail in this report are opinions expressed by TA Technology (Shanghai) Co., Ltd. based on interpretations and/or observations of test results. Measurement Uncertainties were not taken into account and are published for informational purposes only.

2312FPCA6G (Report No.: R2309A0988-R3) is a variant model of 23117RA68G (Report No.: R2309A0986-R3).

The difference between the two models is shown in the table below:

Item	Original	Variant
Brand	Redmi	POCO
Model	23117RA68G	2312FPCA6G
Camera(back) Spec	200M+OIS+8M uw	64M+OIS+8M uw
Battery cover material (the thickness are same)	Glass (thickness: 0.68mm)	PC+PMMA (thickness: 0.71mm)
Others	The same	

This report only tested Radiated Spurious Emission (Upper Antenna: LTE Band 7 QPSK 5MHz CH-Middle, RB 1), and did not worsen, so they were not recorded in the report.

Test values all duplicated from Original for variant.

The detailed product change description please refers to the *Difference Declaration Letter*.

1 Test Laboratory

1.1 Notes of the Test Report

This report shall not be reproduced in full or partial, without the written approval of **TA Technology (Shanghai) Co., Ltd.** The results documented in this report apply only to the tested sample, under the conditions and modes of operation as described herein. Measurement Uncertainties were not taken into account and are published for informational purposes only. This report is written to support regulatory compliance of the applicable standards stated above.

1.2. Test facility

FCC (Designation number: CN1179, Test Firm Registration Number: 446626)

TA Technology (Shanghai) Co., Ltd. has been listed on the US Federal Communications Commission list of test facilities recognized to perform measurements.

A2LA (Certificate Number: 3857.01)

TA Technology (Shanghai) Co., Ltd. has been listed by American Association for Laboratory Accreditation to perform measurement.

1.3 Testing Location

Company: TA Technology (Shanghai) Co., Ltd.
 Address: Building 3, No.145, Jintang Rd, Pudong Shanghai, P.R.China
 City: Shanghai
 Post code: 201201
 Country: P. R. China
 Contact: Xu Kai
 Telephone: +86-021-50791141/2/3
 Fax: +86-021-50791141/2/3-8000
 Website: <http://www.ta-shanghai.com>
 E-mail: xukai@ta-shanghai.com

2 General Description of Equipment under Test

2.1 Applicant and Manufacturer Information

Applicant	Xiaomi Communications Co., Ltd.
Applicant address	#019, 9th Floor, Building 6, 33 Xi'erqi Middle Road, Haidian District, Beijing, China, 100085
Manufacturer	Xiaomi Communications Co., Ltd.
Manufacturer address	#019, 9th Floor, Building 6, 33 Xi'erqi Middle Road, Haidian District, Beijing, China, 100085

2.2 General information

EUT Description			
Model	2312FPCA6G		
IMEI	Original	Conducted	IMEI 1: 863357060106127 IMEI 2: 863357060106135
		Radiated	IMEI 1: 863357060105624 IMEI 2: 863357060105632
	Variant	Radiated	IMEI 1: 867584060055626 IMEI 2: 867584060055634
Hardware Version	135100N6M0A01		
Software Version	MIUI 14		
Antenna Type	PIFA Antenna		
Antenna Gain	Band	Low Antenna	Upper Antenna
	WCDMA Band IV	0.66 dBi	-0.70 dBi
	LTE Band 4	0.66 dBi	-0.60 dBi
	LTE Band 7	2.00 dBi	-1.20 dBi
	LTE Band 12	-5.03 dBi	-7.96 dBi
	LTE Band 13	-5.03 dBi	-7.96 dBi
	LTE Band 17	-5.03 dBi	-7.96 dBi
	LTE Band 38	-1.46 dBi	-1.46 dBi
	LTE Band 41	-1.26 dBi	-1.26 dBi
	LTE Band 66	0.66 dBi	-0.54 dBi
Test Mode(s)	WCDMA Band IV; LTE Band 4/7/12/13/17/38/41/66		
Test Modulation	(WCDMA) BPSK, QPSK, 16QAM; (LTE) QPSK, 16QAM, 64QAM;		
HSDPA UE Category	24		
HSUPA UE Category	7		
LTE Category	13		
Maximum E.I.R.P./ E.R.P.	WCDMA Band IV	25.03 dBm	

	LTE Band 4	26.16 dBm	
	LTE Band 7	26.95 dBm	
	LTE Band 12	17.80 dBm	
	LTE Band 13	18.05 dBm	
	LTE Band 17	17.69 dBm	
	LTE Band 38	23.68 dBm	
	LTE Band 41	24.10 dBm	
	LTE Band 66	26.17 dBm	
Rated Power Supply Voltage	3.89V		
Operating Voltage	Minimum: 3.60V Maximum: 4.48V		
Operating Temperature	Lowest: 0°C Highest: +40°C		
Testing Temperature	Lowest: -30°C Highest: +50°C		
Operating Frequency Range(s)	Mode	Tx (MHz)	Rx (MHz)
	WCDMA Band IV	1710 ~ 1755	2110 ~ 2155
	LTE Band 4	1710 ~ 1755	2110 ~ 2155
	LTE Band 7	2500 ~ 2570	2620 ~ 2690
	LTE Band 12	699 ~ 716	729 ~ 746
	LTE Band 13	777 ~ 787	746 ~ 756
	LTE Band 17	704 ~ 716	734 ~ 746
	LTE Band 38	2570 ~ 2620	2570 ~ 2620
	LTE Band 41	2496 ~ 2690	2496 ~ 2690
	LTE Band 66	1710 ~ 1780	2110 ~ 2180
Note: 1. The EUT is sent from the applicant to TA and the information of the EUT is declared by the applicant.			

3 Applied Standards

According to the specifications of the manufacturer, it must comply with the requirements of the following standards:

Test standards:

FCC CFR47 Part 27C (2022)

FCC CFR47 Part 2 (2022)

Reference standard:

ANSI C63.26-2015

KDB 971168 D01 Power Meas License Digital Systems v03r01

4 Test Configuration

There is more than one SIM card slot, each one should be applied throughout the compliance test respectively, and however, only the worst case (SIM 1) will be recorded in this report

Radiated measurements are performed by rotating the EUT in three different orthogonal test planes. EUT stand-up position (Z axis), lie-down position (X, Y axis). Receiver antenna polarization (horizontal and vertical), the worst emission was found in position (Low Antenna: X axis, vertical polarization for WCDMA and Y axis, horizontal polarization for LTE; Upper Antenna: Y axis, horizontal polarization for WCDMA and X axis, vertical polarization for LTE) and the worst case was recorded.

All mode and data rates and positions and RB size and modulations were investigated.

Subsequently, only the worst case emissions are reported.

The following testing in WCDMA/LTE is set based on the maximum RF Output Power.

The following testing in different Bandwidth is set to detail in the following table:

Test modes are chosen to be reported as the worst case configuration below:

Test items	Modes/Modulation
	WCDMA Band IV
RF Power Output and Effective Isotropic Radiated Power	RMC HSDPA/HSUPA DC-HSDPA/HSPA+
Occupied Bandwidth	RMC
Band Edge Compliance	RMC
Peak-to-Average Power Ratio	RMC
Frequency Stability	RMC
Spurious Emissions at Antenna Terminals	RMC
Radiated Spurious Emission	RMC

Test modes are chosen to be reported as the worst case configuration below for LTE Band 4/7/12/13/17/38/41/66:

Test items	Modes	Bandwidth (MHz)						Modulation		RB			Test Channel		
		1.4	3	5	10	15	20	QPSK	16QAM/ 64QAM	1	50%	100%	L	M	H
RF Power Output and Effective Isotropic Radiated Power	LTE 4	0	0	0	0	0	0	0	0	0	0	0	0	0	0
	LTE 7	-	-	0	0	0	0	0	0	0	0	0	0	0	0
	LTE 12	0	0	0	0	-	-	0	0	0	0	0	0	0	0
	LTE 13	-	-	0	0	-	-	0	0	0	0	0	0	0	0
	LTE 17	-	-	0	0	-	-	0	0	0	0	0	0	0	0
	LTE 38	-	-	0	0	0	0	0	0	0	0	0	0	0	0
	LTE 41	-	-	0	0	0	0	0	0	0	0	0	0	0	0
	LTE 66	0	0	0	0	0	0	0	0	0	0	0	0	0	0
Occupied Bandwidth	LTE 4	0	0	0	0	0	0	0	0	-	-	0	0	0	0
	LTE 7	-	-	0	0	0	0	0	0	-	-	0	0	0	0
	LTE 12	0	0	0	0	-	-	0	0	-	-	0	0	0	0
	LTE 13	-	-	0	0	-	-	0	0	-	-	0	0	0	0
	LTE 17	-	-	0	0	-	-	0	0	-	-	0	0	0	0
	LTE 38	-	-	0	0	0	0	0	0	-	-	0	0	0	0
	LTE 41	-	-	0	0	0	0	0	0	-	-	0	0	0	0
	LTE 66	0	0	0	0	0	0	0	0	-	-	0	0	0	0
Band Edge Compliance	LTE 4	0	0	0	0	0	0	0	0	0	-	0	0	-	0
	LTE 7	-	-	0	0	0	0	0	0	0	-	0	0	-	0
	LTE 12	0	0	0	0	-	-	0	0	0	-	0	0	-	0
	LTE 13	-	-	0	0	-	-	0	0	0	-	0	0	-	0
	LTE 17	-	-	0	0	-	-	0	0	0	-	0	0	-	0
	LTE 38	-	-	0	0	0	0	0	0	0	-	0	0	-	0
	LTE 41	-	-	0	0	0	0	0	0	0	-	0	0	-	0
	LTE 66	0	0	0	0	0	0	0	0	0	-	0	0	-	0
Peak-to-Average Power Ratio	LTE 4	0	0	0	0	0	0	0	0	-	-	0	0	0	0
	LTE 7	-	-	0	0	0	0	0	0	-	-	0	0	0	0
	LTE 12	0	0	0	0	-	-	0	0	-	-	0	0	0	0
	LTE 13	-	-	0	0	-	-	0	0	-	-	0	0	0	0
	LTE 17	-	-	0	0	-	-	0	0	-	-	0	0	0	0
	LTE 38	-	-	0	0	0	0	0	0	-	-	0	0	0	0
	LTE 41	-	-	0	0	0	0	0	0	-	-	0	0	0	0
	LTE 66	0	0	0	0	0	0	0	0	-	-	0	0	0	0
Frequency Stability	LTE 4	0	0	0	0	0	0	0	0	0	-	-	-	0	-
	LTE 7	-	-	0	0	0	0	0	0	0	-	-	-	0	-
	LTE 12	0	0	0	0	-	-	0	0	0	-	-	-	0	-
	LTE 13	-	-	0	0	-	-	0	0	0	-	-	-	0	-
	LTE 17	-	-	0	0	-	-	0	0	0	-	-	-	0	-

	LTE 38	-	-	O	O	O	O	O	O	O	-	-	-	O	-
	LTE 41	-	-	O	O	O	O	O	O	O	-	-	-	O	-
	LTE 66	O	O	O	O	O	O	O	O	O	-	-	-	O	-
Spurious Emissions at Antenna Terminals	LTE 4	O	O	O	O	O	O	O	-	O	-	-	O	O	O
	LTE 7	-	-	O	O	O	O	O	-	O	-	-	O	O	O
	LTE 12	O	O	O	O	-	-	O	-	O	-	-	O	O	O
	LTE 13	-	-	O	O	-	-	O	-	O	-	-	O	O	O
	LTE 17	-	-	O	O	-	-	O	-	O	-	-	O	O	O
	LTE 38	-	-	O	O	O	O	O	-	O	-	-	O	O	O
	LTE 41	-	-	O	O	O	O	O	-	O	-	-	O	O	O
	LTE 66	O	O	O	O	O	O	O	-	O	-	-	O	O	O
Radiated Spurious Emission	LTE 4	O	-	O	-	-	O	O	-	O	-	-	-	O	-
	LTE 7	-	-	O	-	-	O	O	-	O	-	-	-	O	-
	LTE 12	O	-	O	O	-	-	O	-	O	-	-	-	O	-
	LTE 13	-	-	O	O	-	-	O	-	O	-	-	-	O	-
	LTE 17	-	-	O	O	-	-	O	-	O	-	-	-	O	-
	LTE 38	-	-	O	-	-	O	O	-	O	-	-	-	O	-
	LTE 41	-	-	O	-	-	O	O	-	O	-	-	-	O	-
	LTE 66	O	-	O	-	-	O	O	-	O	-	-	-	O	-
Note	1. The mark "O" means that this configuration is chosen for testing. 2. The mark "-" means that this configuration is not testing.														

5 Test Case

5.1 RF Power Output and Effective Isotropic Radiated Power

Ambient condition

Temperature	Relative humidity	Pressure
23°C ~25°C	45%~50%	101.5kPa

Methods of Measurement

During the process of the testing, The EUT was connected to the Base Station Simulator with a known loss. The EUT is controlled by the Base Station Simulator test set to ensure max power transmission with proper modulation.

ERP can then be calculated as follows:

$$\text{EIRP (dBm)} = \text{Output Power (dBm)} + \text{Antenna Gain (dBi)}$$

$$\text{EIRP (dBm)} = \text{ERP (dBm)} + 2.15 \text{ (dB.)}$$

Test Setup

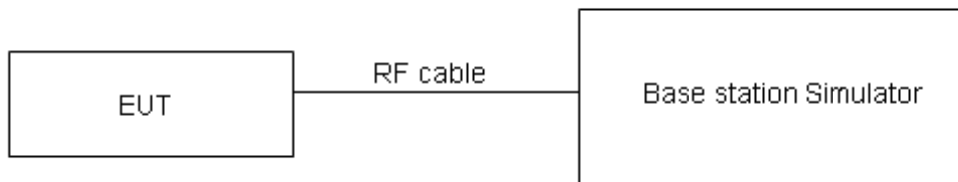

Limits

No specific RF power output requirements in part 2.1046.

Rule Part 27.50(b) (10) specifies that “Portable stations (hand-held devices) transmitting in the 746-757 MHz, 776-788 MHz, and 805-806 MHz bands are limited to 3 watts ERP”

Rule Part 27.50(c) (10) specifies that “Portable stations (hand-held devices) in the 600 MHz uplink band and the 698-746 MHz band, and fixed and mobile stations in the 600 MHz uplink band are limited to 3 watts ERP”

Rule Part 27.50(d) (4) specifies that “Fixed, mobile and portable (hand-held) stations operating in the 1710–1755 MHz band are limited to 1 watt EIRP”

Rule Part 27.50(h) (2) specifies that “Mobile and other user stations. Mobile stations are limited to 2.0 watts EIRP. All user stations are limited to 2.0 watts transmitter output power.”

Part 27.50(b)(10)Limit	$\leq 3 \text{ W}$ (34.77 dBm)
Part 27.50(c)(10)Limit	$\leq 3 \text{ W}$ (34.77 dBm)
Part 27.50(d)(4)Limit	$\leq 1 \text{ W}$ (30 dBm)
Part 27.50(h)(2) Limit	$\leq 2 \text{ W}$ (33 dBm)

Measurement Uncertainty

The assessed measurement uncertainty to ensure 95% confidence level for the normal distribution is with the coverage factor $k = 2$, $U=0.4$ dB for RF power output, $k = 2$, $U= 1.19$ dB for ERP/EIRP.

Test Results

Refer to the section 6.1 of this report for test data.

5.2 Occupied Bandwidth

Ambient condition

Temperature	Relative humidity	Pressure
23°C ~25°C	45%~50%	101.5kPa

Method of Measurement

The EUT was connected to Spectrum Analyzer and Base Station Simulator via power Splitter. The occupied bandwidth is measured using spectrum analyzer.

RBW is set to $\geq 1\%EBW$, VBW is set to 3x RBW.

99% power and -26dBc occupied bandwidths are recorded. Spectrum analyzer plots are included on the following pages.

Test Setup

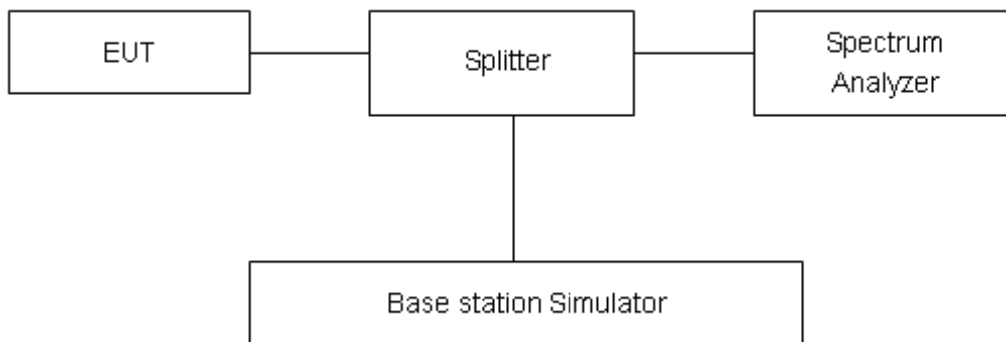

Limits

No specific occupied bandwidth requirements in part 2.1049.

Measurement Uncertainty

The assessed measurement uncertainty to ensure 95% confidence level for the normal distribution is with the coverage factor $k = 2$, $U=624\text{Hz}$.

Test Results

Refer to the section 6.2 of this report for test data.

5.3 Band Edge Compliance

Ambient condition

Temperature	Relative humidity	Pressure
23°C ~25°C	45%~50%	101.5kPa

Method of Measurement

The EUT was connected to Spectrum Analyzer and Base Station Simulator via power Splitter. The band edge of the lowest and highest channels were measured.

The testing follows KDB 971168 D01 v03r01 Section 6.0

The EUT was connected to spectrum analyzer and system simulator via a power divider.

The band edges of low and high channels for the highest RF powers were measured.

For LTE Band 7/38 set RBW \geq 1% EBW in the 1MHz band immediately outside and adjacent to the band edge. Beyond the 1 MHz band from the band edge, RBW=1MHz was used.

For LTE Band 41 the middle channel, high channel set RBW \geq 1% EBW in the 1MHz band immediately outside and adjacent to the band edge. Beyond the 1 MHz band from the band edge, RBW=1MHz was used; Low channel set RBW \geq 2% EBW in the 1MHz band immediately outside and adjacent to the band edge. Beyond the 1 MHz band from the band edge, RBW=1MHz was used. RBW is set to \geq 1%EBW, VBW is set to 3x RBW on spectrum analyzer.

Set spectrum analyzer with RMS detector.

The RF fundamental frequency should be excluded against the limit line in the operating frequency band.

Checked that all the results comply with the emission limit line.

Test Setup

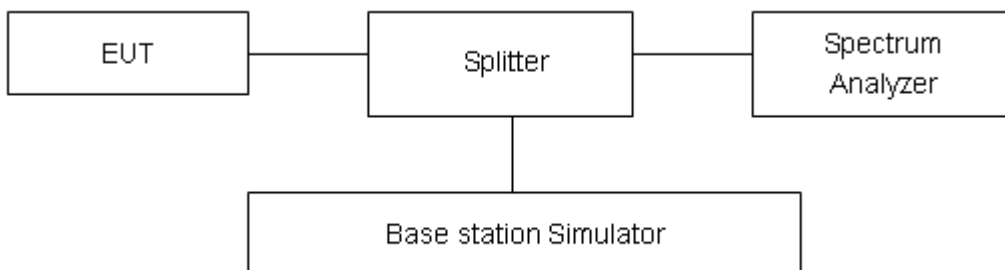

Limits

Rule Part 27.53(h) specifies that “ for operations in the 1695-1710 MHz, 1710-1755 MHz, 1755-1780 MHz, 1915-1920 MHz, 1995-2000 MHz, 2000-2020 MHz, 2110-2155 MHz, 2155-2180 MHz, and 2180-2200 bands, the power of any emission outside a licensee's frequency block shall be attenuated below the transmitter power (P) in watts by at least $43 + 10 \log_{10} (P)$ dB”

Rule Part 27.53(g) For operations in the 600 MHz band and the 698-746 MHz band, the power of any emission outside a licensee's frequency band(s) of operation shall be attenuated below the transmitter power (P) within the licensed band(s) of operation, measured in watts, by at least $43 + 10$

log (P) dB. Compliance with this provision is based on the use of measurement instrumentation employing a resolution bandwidth of 100 kilohertz or greater. However, in the 100 kilohertz bands immediately outside and adjacent to a licensee's frequency block, a resolution bandwidth of at least 30 kHz may be employed.

Rule Part 27.53(m) (4) specifies that “for BRS and EBS stations. For mobile digital stations, the attenuation factor shall be not less than $40 + 10 \log (P)$ dB on all frequencies between the channel edge and 5 megahertz from the channel edge, $43 + 10 \log (P)$ dB on all frequencies between 5 megahertz and X megahertz from the channel edge, and $55 + 10 \log (P)$ dB on all frequencies more than X megahertz from the channel edge, where X is the greater of 6 megahertz or the actual emission bandwidth as defined in paragraph (m)(4) of this section. In addition, the attenuation factor shall not be less that $43 + 10 \log (P)$ dB on all frequencies between 2490.5 MHz and 2496 MHz and $55 + 10 \log (P)$ dB at or below 2490.5 MHz. Mobile Satellite Service licensees operating on frequencies below 2495 MHz may also submit a documented interference complaint against BRS licensees operating on channel BRS Channel 1 on the same terms and conditions as adjacent channel BRS or EBS licensees.

Example:

The limit line is derived from $43 + 10 \log (P)$ dB below the transmitter power P(Watts)
 $= P(W) - [43 + 10 \log (P)]$ (dB)
 $= [30 + 10 \log (P)]$ (dBm) - $[43 + 10 \log (P)]$ (dB) = -13dBm.

Rule Part 27.53(f) For operations in the 746-758 MHz, 775-788 MHz, and 805-806 MHz bands, emissions in the band 1559-1610 MHz shall be limited to -70 dBW/MHz equivalent isotropically radiated power (EIRP) for wideband signals, and -80 dBW EIRP for discrete emissions of less than 700 Hz bandwidth. For the purpose of equipment authorization, a transmitter shall be tested with an antenna that is representative of the type that will be used with the equipment in normal operation.

Rule Part 27.53 (c) For operations in the 746-758 MHz band and the 776-788 MHz band, the power of any emission outside the licensee's frequency band(s) of operation shall be attenuated below the transmitter power (P) within the licensed band(s) of operation, measured in watts, in accordance with the following:

- (1) On any frequency outside the 746-758 MHz band, the power of any emission shall be attenuated outside the band below the transmitter power (P) by at least $43 + 10 \log (P)$ dB;
- (2) On any frequency outside the 776-788 MHz band, the power of any emission shall be attenuated outside the band below the transmitter power (P) by at least $43 + 10 \log (P)$ dB;
- (3) On all frequencies between 763-775 MHz and 793-805 MHz, by a factor not less than $76 + 10 \log (P)$ dB in a 6.25 kHz band segment, for base and fixed stations;
- (4) On all frequencies between 763-775 MHz and 793-805 MHz, by a factor not less than $65 + 10 \log (P)$ dB in a 6.25 kHz band segment, for mobile and portable stations;
- (5) Compliance with the provisions of paragraphs (c)(1) and (c)(2) of this section is based on the use of measurement instrumentation employing a resolution bandwidth of 100 kHz or greater. However, in the 100 kHz bands immediately outside and adjacent to the frequency block, a resolution bandwidth of at least 30 kHz may be employed;

Measurement Uncertainty

The assessed measurement uncertainty to ensure 95% confidence level for the normal distribution is with the coverage factor $k = 1.96$, $U=0.684\text{dB}$.

Test Results

Refer to the section 6.3 of this report for test data.

5.4 Peak-to-Average Power Ratio (PAPR)

Ambient condition

Temperature	Relative humidity	Pressure
23°C ~25°C	45%~50%	101.5kPa

Methods of Measurement

Measure the total peak power and record as PPk. And measure the total average power and record as PAvg. Both the peak and average power levels must be expressed in the same logarithmic units (e.g., dBm). Determine the PAPR from:

$$\text{PAPR (dB)} = \text{PPk (dBm)} - \text{PAvg (dBm)}$$

Test Setup

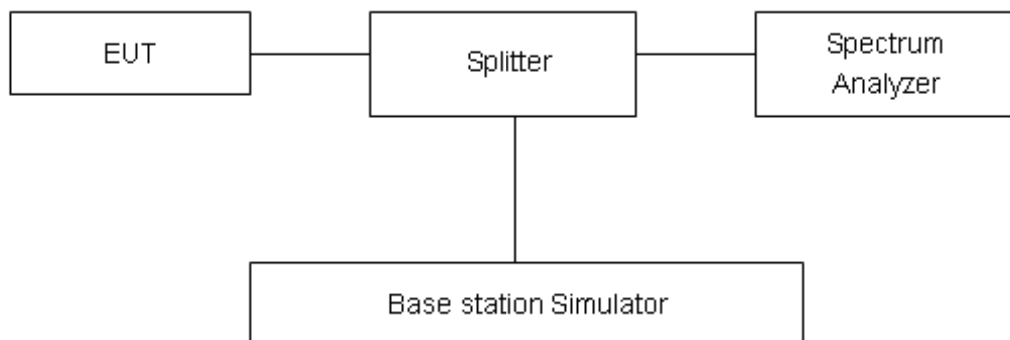

Limits

Rule Part 27.50(d)(5) Equipment employed must be authorized in accordance with the provisions of 24.51. Power measurements for transmissions by stations authorized under this section may be made either in accordance with a Commission-approved average power technique or in compliance with paragraph (d)(6) of this section. In measuring transmissions in this band using an average power technique, the peak-to-average ratio (PAR) of the transmission may not exceed 13 dB.

Measurement Uncertainty

The assessed measurement uncertainty to ensure 95% confidence level for the normal distribution is with the coverage factor $k = 2$, $U = 0.4$ dB.

Test Results

Refer to the section 6.4 of this report for test data.

5.5 Frequency Stability

Ambient condition

Temperature	Relative humidity	Pressure
23°C ~25°C	45%~50%	101.5kPa

Method of Measurement

Frequency Stability (Temperature Variation)

The temperature inside the climate chamber is varied from -30°C to +50°C in 10°C step size.

(1)With all power removed, the temperature was decreased to -10°C and permitted to stabilize for three hours.

(2)Measure the carrier frequency with the test equipment in a “call mode”. These measurements should be made within 1 minute of powering up the mobile station, to prevent significant self warming.

(3) Repeat the above measurements at 10°C increments from -30°C to +50°C. Allow at least 1.5 hours at each temperature, un-powered, before making measurements.

Frequency Stability (Voltage Variation)

The frequency stability shall be measured with variation of primary supply voltage as follows:

Primary Supply Voltage: The primary supply voltage is varied from 85% to 115% of the nominal value for non hand-carried battery and AC powered equipment. For hand-carried, battery-powered equipment, primary supply voltage is reduced to the battery operating end point which shall be specified by the manufacturer.

This transceiver is specified to operate with an input voltage of between 3.6 V and 4.48 V, with a nominal voltage of 3.89V.

Test setup

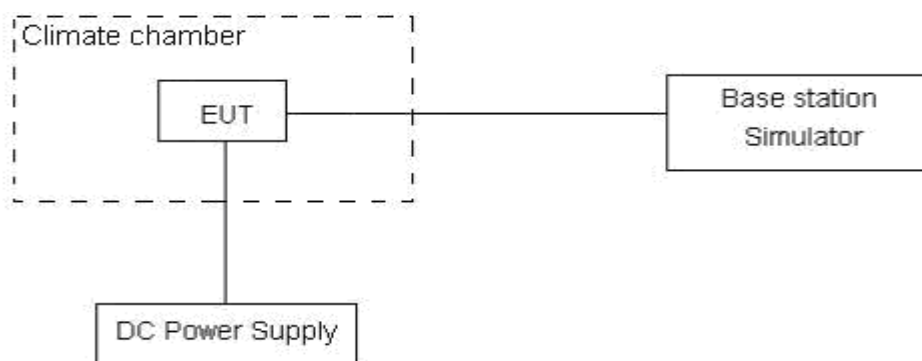

Limits

The frequency stability shall be sufficient to ensure that the fundamental emissions stay within the authorized bands of operation.

Measurement Uncertainty

The assessed measurement uncertainty to ensure 99.75% confidence level for the normal distribution is with the coverage factor $k = 3, U=0.01\text{ppm}$.

Test Results

Refer to the section 6.5 of this report for test data.

5.6 Spurious Emissions at Antenna Terminals

Ambient condition

Temperature	Relative humidity	Pressure
23°C ~25°C	45%~50%	101.5kPa

Method of Measurement

The EUT was connected to Spectrum Analyzer and Base Station Simulator via power Splitter. The measurement is carried out using a spectrum analyzer. The spectrum analyzer scans from 9kHz to the 10th harmonic of the carrier. The peak detector is used.

RBW is set to 1 kHz (0.009MHz~ 0.15 MHz),

RBW is set to 10 kHz (0.15 MHz~ 30 MHz)

RBW is set to 100 kHz (30MHz~1000 MHz)

RBW is set to 1000 kHz (above 1000MHz)

Sweep is set to AUTO.

Of those disturbances below (limit – 20 dB), the mark is not required for the EUT.

The modulation mode and RB allocation refer to section 5.1, using the maximum output power configuration.

Test setup

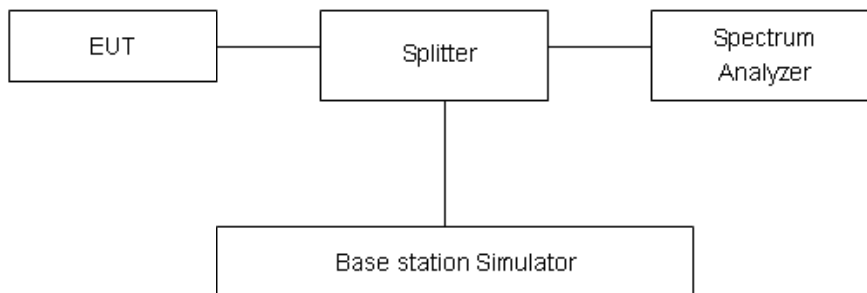

Limits

Rule Part 27.53(h) specifies that “for operations in the 1695-1710 MHz, 1710-1755 MHz, 1755-1780 MHz, 1915-1920 MHz, 1995-2000 MHz, 2000-2020 MHz, 2110-2155 MHz, 2155-2180 MHz, and 2180-2200 bands, the power of any emission outside a licensee's frequency block shall be attenuated below the transmitter power (P) in watts by at least $43 + 10 \log_{10}(P)$ dB.”

Rule Part 27.53 (g) For operations in the 600 MHz band and the 698-746 MHz band, the power of any emission outside a licensee's frequency band(s) of operation shall be attenuated below the transmitter power (P) within the licensed band(s) of operation, measured in watts, by at least $43 + 10 \log(P)$ dB. Compliance with this provision is based on the use of measurement instrumentation employing a resolution bandwidth of 100 kilohertz or greater. However, in the 100 kilohertz bands immediately outside and adjacent to a licensee's frequency block, a resolution bandwidth of at least 30 kHz may be employed.

Rule Part 27.53(f) For operations in the 746-758 MHz, 775-788 MHz, and 805-806 MHz bands,

emissions in the band 1559-1610 MHz shall be limited to -70 dBW/MHz equivalent isotropically radiated power (EIRP) for wideband signals, and -80 dBW EIRP for discrete emissions of less than 700 Hz bandwidth. For the purpose of equipment authorization, a transmitter shall be tested with an antenna that is representative of the type that will be used with the equipment in normal operation. Rule Part 27.53(m) $55 + 10 \log (P)$ dB on all frequencies more than X megahertz from the channel edge, where X is the greater of 6 megahertz or the actual emission bandwidth as defined in paragraph (m)(4) of this section.

Part 27.53 (c) For operations in the 746-758 MHz band and the 776-788 MHz band, the power of any emission outside the licensee's frequency band(s) of operation shall be attenuated below the transmitter power (P) within the licensed band(s) of operation, measured in watts, in accordance with the following:

- (1) On any frequency outside the 746-758 MHz band, the power of any emission shall be attenuated outside the band below the transmitter power (P) by at least $43 + 10 \log (P)$ dB;
- (2) On any frequency outside the 776-788 MHz band, the power of any emission shall be attenuated outside the band below the transmitter power (P) by at least $43 + 10 \log (P)$ dB;
- (3) On all frequencies between 763-775 MHz and 793-805 MHz, by a factor not less than $76 + 10 \log (P)$ dB in a 6.25 kHz band segment, for base and fixed stations;
- (4) On all frequencies between 763-775 MHz and 793-805 MHz, by a factor not less than $65 + 10 \log (P)$ dB in a 6.25 kHz band segment, for mobile and portable stations;
- (5) Compliance with the provisions of paragraphs (c)(1) and (c)(2) of this section is based on the use of measurement instrumentation employing a resolution bandwidth of 100 kHz or greater. However, in the 100 kHz bands immediately outside and adjacent to the frequency block, a resolution bandwidth of at least 30 kHz may be employed;

Part 27.53(h)/(g) Limit		-13 dBm
Part 27.53(f) Limit	Limit out of the band 1559-1610 MHz	-13 dBm
	Limit in the band 1559-1610 MHz	-40 dBm
Part 27.53(m) Limit		-25 dBm

Measurement Uncertainty

The assessed measurement uncertainty to ensure 99.75% confidence level for the normal distribution is with the coverage factor $k = 1.96$.

Frequency	Uncertainty
9kHz-1GHz	0.684 dB
1GHz-30GHz	1.407 dB

Test Results

Refer to the section 6.6 of this report for test data.

5.7 Radiated Spurious Emission

Ambient condition

Temperature	Relative humidity	Pressure
23°C ~25°C	45%~50%	101.5kPa

Method of Measurement

- The testing follows FCC KDB 971168 D01 v03r01 Section 5.8 and ANSI C63.26-2015.
- Below 1GHz: The EUT is placed on a turntable 0.8 meters above the ground in the chamber, 3 meter away from the antenna. The maximal emission value is acquired by adjusting the antenna height, polarisation and turntable azimuth. Normally, the height range of antenna is 1 m to 4 m, the azimuth range of turntable is 0° to 360°, and the receive antenna has two polarizations Vertical (V) and Horizontal (H). Above 1GHz: (Note: the FCC's permission to use 1.5m as an alternative per TCBC Conf call of Dec. 2, 2014.) The EUT is placed on a turntable 1.5 meters above the ground in the chamber, 3 meter away from the antenna. The maximal emission value is acquired by adjusting the antenna height, polarisation and turntable azimuth. Normally, the height range of antenna is 1 m to 4 m, the azimuth range of turntable is 0° to 360°, and the receive antenna has two polarizations Vertical (V) and Horizontal (H).
- A loop antenna, A log-periodic antenna or horn antenna shall be substituted in place of the EUT. The log-periodic antenna will be driven by a signal generator and the level will be adjusted till the same power value on the spectrum analyzer or receiver. The level of the spurious emissions can be calculated through the level of the signal generator, cable loss, the gain of the substitution antenna and the reading of the spectrum analyzer or receiver.
- The EUT is then put into continuously transmitting mode at its maximum power level during the test. Set Test Receiver or Spectrum RBW=100kHz, VBW=300kHz for 30MHz to 1GHz and RBW=1MHz, VBW=3MHz for above 1GHz, and the maximum value of the receiver should be recorded as (Pr).
- The EUT shall be replaced by a substitution antenna. In the chamber, an substitution antenna for the frequency band of interest is placed at the reference point of the chamber. An RF Signal source for the frequency band of interest is connected to the substitution antenna with a cable that has been constructed to not interfere with the radiation pattern of the antenna. A power (PMea) is applied to the input of the substitution antenna, and adjust the level of the signal generator output until the value of the receiver reach the previously recorded (Pr). The power of signal source (PMea) is recorded. The test should be performed by rotating the test item and adjusting the receiving antenna polarization.
- A amplifier should be connected to the Signal Source output port. And the cable should be connect between the Amplifier and the Substitution Antenna. The cable loss (Pcl) ,the Substitution Antenna Gain (Ga) and the Amplifier Gain (PAg) should be recorded after test.
- The measurement results are obtained as described below:

$$\text{Power(EIRP)} = \text{PMea} - \text{PAg} - \text{Pcl} + \text{Ga}$$
 The measurement results are amend as described below:

$$\text{Power(EIRP)} = \text{PMea} - \text{Pcl} + \text{Ga}$$
- This value is EIRP since the measurement is calibrated using an antenna of known gain (2.15 dB) and known input power. ERP can be calculated from EIRP by subtracting the gain of the dipole, $\text{ERP} = \text{EIRP} - 2.15\text{dB}$.

The modulation mode and RB allocation refer to section 5.1, using the maximum output power configuration.

Test setup

9KHz~ 30MHz

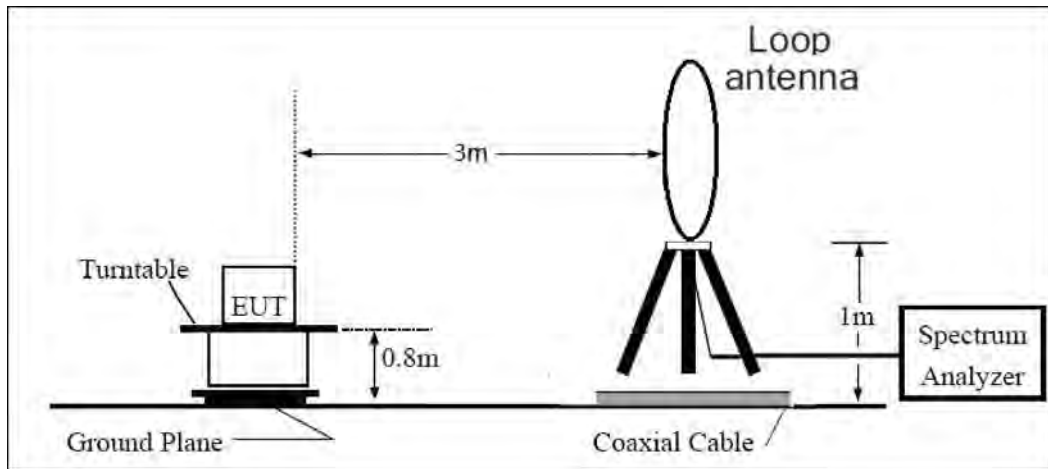

30MHz~ 1GHz

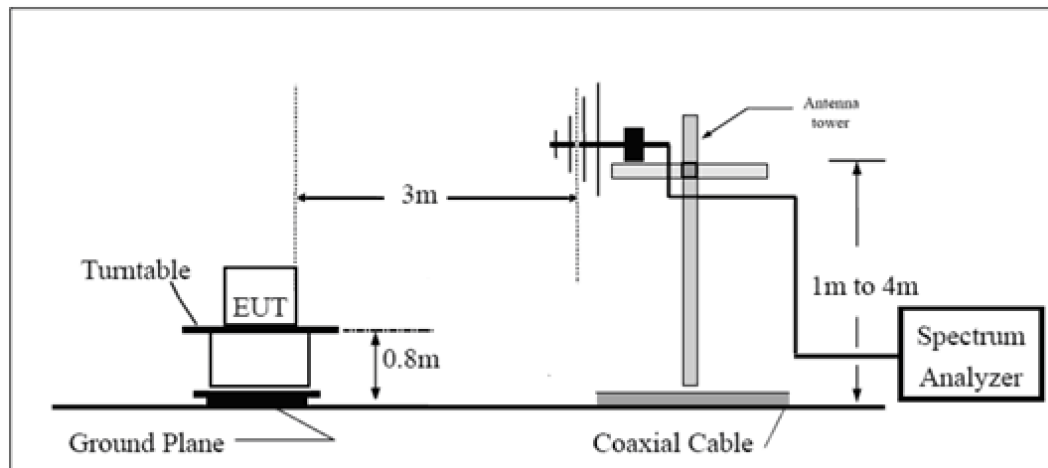

Above 1GHz

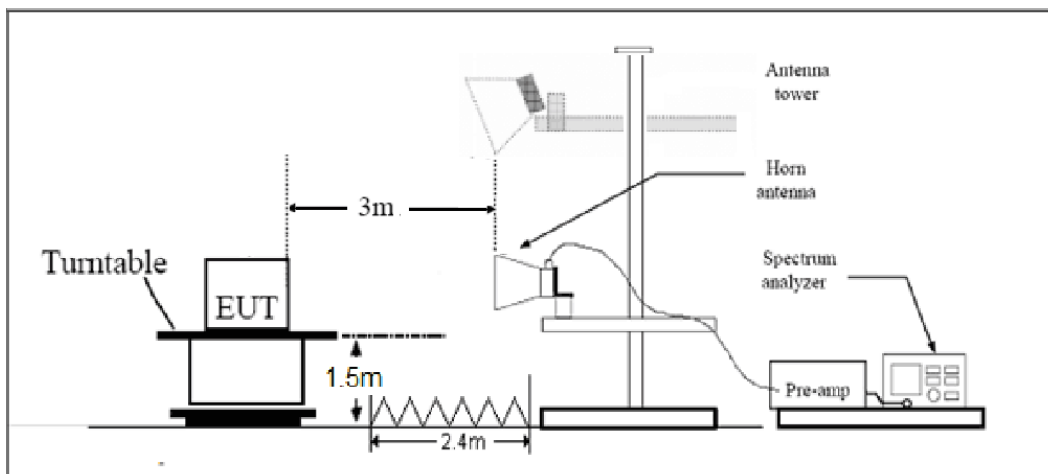

Note: Area side:2.4mX3.6m

Limits

Rule Part 27.53(h) specifies that “for operations in the 1695-1710 MHz, 1710-1755 MHz, 1755-1780 MHz, 1915-1920 MHz, 1995-2000 MHz, 2000-2020 MHz, 2110-2155 MHz, 2155-2180 MHz, and 2180-2200 bands, the power of any emission outside a licensee's frequency block shall be attenuated below the transmitter power (P) in watts by at least $43 + 10 \log_{10}(P)$ dB.”

Rule Part 27.53 (g) For operations in the 600 MHz band and the 698-746 MHz band, the power of any emission outside a licensee's frequency band(s) of operation shall be attenuated below the transmitter power (P) within the licensed band(s) of operation, measured in watts, by at least $43 + 10 \log(P)$ dB. Compliance with this provision is based on the use of measurement instrumentation employing a resolution bandwidth of 100 kilohertz or greater. However, in the 100 kilohertz bands immediately outside and adjacent to a licensee's frequency block, a resolution bandwidth of at least 30 kHz may be employed.

Rule Part 27.53(m) $55 + 10 \log(P)$ dB on all frequencies more than X megahertz from the channel edge, where X is the greater of 6 megahertz or the actual emission bandwidth as defined in paragraph (m)(4) of this section.

Rule Part 27.53(f) For operations in the 746-758 MHz, 775-788 MHz, and 805-806 MHz bands, emissions in the band 1559-1610 MHz shall be limited to -70 dBW/MHz equivalent isotropically radiated power (EIRP) for wideband signals, and -80 dBW EIRP for discrete emissions of less than 700 Hz bandwidth. For the purpose of equipment authorization, a transmitter shall be tested with an antenna that is representative of the type that will be used with the equipment in normal operation.

Part 27.53 (c) For operations in the 746-758 MHz band and the 776-788 MHz band, the power of any emission outside the licensee's frequency band(s) of operation shall be attenuated below the transmitter power (P) within the licensed band(s) of operation, measured in watts, in accordance with the following:

- (1) On any frequency outside the 746-758 MHz band, the power of any emission shall be attenuated outside the band below the transmitter power (P) by at least $43 + 10 \log(P)$ dB;
- (2) On any frequency outside the 776-788 MHz band, the power of any emission shall be attenuated outside the band below the transmitter power (P) by at least $43 + 10 \log(P)$ dB;
- (3) On all frequencies between 763-775 MHz and 793-805 MHz, by a factor not less than $76 + 10 \log(P)$ dB in a 6.25 kHz band segment, for base and fixed stations;
- (4) On all frequencies between 763-775 MHz and 793-805 MHz, by a factor not less than $65 + 10 \log(P)$ dB in a 6.25 kHz band segment, for mobile and portable stations;
- (5) Compliance with the provisions of paragraphs (c)(1) and (c)(2) of this section is based on the use of measurement instrumentation employing a resolution bandwidth of 100 kHz or greater. However, in the 100 kHz bands immediately outside and adjacent to the frequency block, a resolution bandwidth of at least 30 kHz may be employed;

Part 27.53 (h)/(g) Limit		-13 dBm
Part 27.53(f) Limit	Limit out of the band 1559-1610 MHz	-13 dBm
	Limit in the band 1559-1610 MHz	-40 dBm
Part 27.53(m) Limit		-25 dBm

Measurement Uncertainty

The assessed measurement uncertainty to ensure 95% confidence level for the normal distribution is with the coverage factor $k = \pm 1.96$, $U = \pm 3.55$ dB.

Test Results

Refer to the section 6.7 of this report for test data.

6 Test Results

6.1 RF Power Output and Effective Isotropic Radiated Power

Low Antenna

WCDMA Band IV		Conducted Power (dBm)			EIRP (dBm)		
		Channel/ Frequency			Channel/ Frequency		
		1312/1712.4	1413/1732.6	1513/1752.6	1312/1712.4	1413/1732.6	1513/1752.6
RMC	12.2k	24.37	24.20	24.27	25.03	24.86	24.93
HSDPA	Subtest 1	23.79	23.62	23.69	24.45	24.28	24.35
	Subtest 2	23.78	23.61	23.68	24.44	24.27	24.34
	Subtest 3	23.27	23.10	23.17	23.93	23.76	23.83
	Subtest 4	23.26	23.09	23.16	23.92	23.75	23.82
HSUPA	Subtest 1	22.75	22.58	22.65	23.41	23.24	23.31
	Subtest 2	20.74	20.57	20.64	21.40	21.23	21.30
	Subtest 3	21.72	21.56	21.63	22.38	22.22	22.29
	Subtest 4	20.71	20.55	20.62	21.37	21.21	21.28
	Subtest 5	24.20	24.04	24.11	24.86	24.70	24.77
DC-HSDPA	Subtest 1	23.71	23.56	23.61	24.37	24.22	24.27
	Subtest 2	23.70	23.55	23.60	24.36	24.21	24.26
	Subtest 3	23.28	23.04	23.11	23.94	23.70	23.77
	Subtest 4	23.27	23.03	23.10	23.93	23.69	23.76
HSPA+	16QAM	21.86	21.71	21.78	22.52	22.37	22.44

LTE Band 4						
Bandwidth (MHz)	UL Channel	RB Size	RB Position	Modulation	Power (dBm)	EIRP (dBm)
1.4	19957	1	#0	QPSK	25.03	25.69
1.4	19957	1	#Mid	QPSK	25.13	25.79
1.4	19957	1	#Max	QPSK	25.15	25.81
1.4	19957	3	#0	QPSK	24.86	25.52
1.4	19957	3	#Mid	QPSK	24.88	25.54
1.4	19957	3	#Max	QPSK	24.93	25.59
1.4	19957	6	#0	QPSK	24.19	24.85
1.4	19957	1	#0	16QAM	23.82	24.48
1.4	19957	1	#Mid	16QAM	23.90	24.56
1.4	19957	1	#Max	16QAM	23.86	24.52
1.4	19957	3	#0	16QAM	23.93	24.59
1.4	19957	3	#Mid	16QAM	23.93	24.59
1.4	19957	3	#Max	16QAM	23.99	24.65
1.4	19957	6	#0	16QAM	23.03	23.69

1.4	20175	1	#0	QPSK	24.84	25.50
1.4	20175	1	#Mid	QPSK	24.88	25.54
1.4	20175	1	#Max	QPSK	24.81	25.47
1.4	20175	3	#0	QPSK	24.82	25.48
1.4	20175	3	#Mid	QPSK	24.80	25.46
1.4	20175	3	#Max	QPSK	24.76	25.42
1.4	20175	6	#0	QPSK	24.00	24.66
1.4	20175	1	#0	16QAM	23.89	24.55
1.4	20175	1	#Mid	16QAM	23.95	24.61
1.4	20175	1	#Max	16QAM	23.92	24.58
1.4	20175	3	#0	16QAM	23.79	24.45
1.4	20175	3	#Mid	16QAM	23.74	24.40
1.4	20175	3	#Max	16QAM	23.76	24.42
1.4	20175	6	#0	16QAM	22.88	23.54
1.4	20393	1	#0	QPSK	24.90	25.56
1.4	20393	1	#Mid	QPSK	24.94	25.60
1.4	20393	1	#Max	QPSK	24.89	25.55
1.4	20393	3	#0	QPSK	24.78	25.44
1.4	20393	3	#Mid	QPSK	24.78	25.44
1.4	20393	3	#Max	QPSK	24.78	25.44
1.4	20393	6	#0	QPSK	23.95	24.61
1.4	20393	1	#0	16QAM	23.59	24.25
1.4	20393	1	#Mid	16QAM	23.63	24.29
1.4	20393	1	#Max	16QAM	23.59	24.25
1.4	20393	3	#0	16QAM	23.67	24.33
1.4	20393	3	#Mid	16QAM	23.66	24.32
1.4	20393	3	#Max	16QAM	23.66	24.32
1.4	20393	6	#0	16QAM	22.89	23.55
3	19965	1	#0	QPSK	24.82	25.48
3	19965	1	#Mid	QPSK	24.94	25.60
3	19965	1	#Max	QPSK	24.85	25.51
3	19965	8	#0	QPSK	24.04	24.70
3	19965	8	#Mid	QPSK	24.03	24.69
3	19965	8	#Max	QPSK	24.07	24.73
3	19965	15	#0	QPSK	23.98	24.64
3	19965	1	#0	16QAM	23.86	24.52
3	19965	1	#Mid	16QAM	23.97	24.63
3	19965	1	#Max	16QAM	23.87	24.53
3	19965	8	#0	16QAM	22.89	23.55
3	19965	8	#Mid	16QAM	22.89	23.55
3	19965	8	#Max	16QAM	22.96	23.62
3	19965	15	#0	16QAM	22.82	23.48
3	20175	1	#0	QPSK	24.81	25.47

3	20175	1	#Mid	QPSK	24.90	25.56
3	20175	1	#Max	QPSK	24.82	25.48
3	20175	8	#0	QPSK	23.94	24.60
3	20175	8	#Mid	QPSK	23.92	24.58
3	20175	8	#Max	QPSK	23.92	24.58
3	20175	15	#0	QPSK	23.92	24.58
3	20175	1	#0	16QAM	23.58	24.24
3	20175	1	#Mid	16QAM	23.65	24.31
3	20175	1	#Max	16QAM	23.53	24.19
3	20175	8	#0	16QAM	22.88	23.54
3	20175	8	#Mid	16QAM	22.89	23.55
3	20175	8	#Max	16QAM	22.85	23.51
3	20175	15	#0	16QAM	22.85	23.51
3	20385	1	#0	QPSK	24.59	25.25
3	20385	1	#Mid	QPSK	24.75	25.41
3	20385	1	#Max	QPSK	24.59	25.25
3	20385	8	#0	QPSK	23.81	24.47
3	20385	8	#Mid	QPSK	23.80	24.46
3	20385	8	#Max	QPSK	23.87	24.53
3	20385	15	#0	QPSK	23.75	24.41
3	20385	1	#0	16QAM	23.72	24.38
3	20385	1	#Mid	16QAM	23.83	24.49
3	20385	1	#Max	16QAM	23.77	24.43
3	20385	8	#0	16QAM	22.78	23.44
3	20385	8	#Mid	16QAM	22.77	23.43
3	20385	8	#Max	16QAM	22.86	23.52
3	20385	15	#0	16QAM	22.77	23.43
5	19975	1	#0	QPSK	24.98	25.64
5	19975	1	#Mid	QPSK	25.21	25.87
5	19975	1	#Max	QPSK	25.12	25.78
5	19975	12	#0	QPSK	24.00	24.66
5	19975	12	#Mid	QPSK	24.01	24.67
5	19975	12	#Max	QPSK	24.06	24.72
5	19975	25	#0	QPSK	24.00	24.66
5	19975	1	#0	16QAM	24.13	24.79
5	19975	1	#Mid	16QAM	24.27	24.93
5	19975	1	#Max	16QAM	24.19	24.85
5	19975	12	#0	16QAM	22.91	23.57
5	19975	12	#Mid	16QAM	22.91	23.57
5	19975	12	#Max	16QAM	23.01	23.67
5	19975	25	#0	16QAM	23.00	23.66
5	20175	1	#0	QPSK	24.99	25.65
5	20175	1	#Mid	QPSK	25.08	25.74

5	20175	1	#Max	QPSK	24.87	25.53
5	20175	12	#0	QPSK	23.95	24.61
5	20175	12	#Mid	QPSK	24.00	24.66
5	20175	12	#Max	QPSK	23.88	24.54
5	20175	25	#0	QPSK	23.92	24.58
5	20175	1	#0	16QAM	24.04	24.70
5	20175	1	#Mid	16QAM	24.12	24.78
5	20175	1	#Max	16QAM	23.93	24.59
5	20175	12	#0	16QAM	22.90	23.56
5	20175	12	#Mid	16QAM	22.90	23.56
5	20175	12	#Max	16QAM	22.82	23.48
5	20175	25	#0	16QAM	22.87	23.53
5	20375	1	#0	QPSK	24.72	25.38
5	20375	1	#Mid	QPSK	24.92	25.58
5	20375	1	#Max	QPSK	24.80	25.46
5	20375	12	#0	QPSK	23.78	24.44
5	20375	12	#Mid	QPSK	23.82	24.48
5	20375	12	#Max	QPSK	23.83	24.49
5	20375	25	#0	QPSK	23.76	24.42
5	20375	1	#0	16QAM	23.90	24.56
5	20375	1	#Mid	16QAM	24.06	24.72
5	20375	1	#Max	16QAM	23.96	24.62
5	20375	12	#0	16QAM	22.82	23.48
5	20375	12	#Mid	16QAM	22.78	23.44
5	20375	12	#Max	16QAM	22.84	23.50
5	20375	25	#0	16QAM	22.80	23.46
10	20000	1	#0	QPSK	25.10	25.76
10	20000	1	#Mid	QPSK	25.24	25.90
10	20000	1	#Max	QPSK	25.36	26.02
10	20000	25	#0	QPSK	23.96	24.62
10	20000	25	#Mid	QPSK	23.98	24.64
10	20000	25	#Max	QPSK	24.18	24.84
10	20000	50	#0	QPSK	24.04	24.70
10	20000	1	#0	16QAM	24.18	24.84
10	20000	1	#Mid	16QAM	24.23	24.89
10	20000	1	#Max	16QAM	24.32	24.98
10	20000	25	#0	16QAM	23.00	23.66
10	20000	25	#Mid	16QAM	23.01	23.67
10	20000	25	#Max	16QAM	23.20	23.86
10	20000	50	#0	16QAM	23.02	23.68
10	20175	1	#0	QPSK	25.11	25.77
10	20175	1	#Mid	QPSK	25.04	25.70
10	20175	1	#Max	QPSK	24.92	25.58

10	20175	25	#0	QPSK	23.97	24.63
10	20175	25	#Mid	QPSK	23.95	24.61
10	20175	25	#Max	QPSK	23.87	24.53
10	20175	50	#0	QPSK	23.98	24.64
10	20175	1	#0	16QAM	24.11	24.77
10	20175	1	#Mid	16QAM	24.10	24.76
10	20175	1	#Max	16QAM	24.02	24.68
10	20175	25	#0	16QAM	22.96	23.62
10	20175	25	#Mid	16QAM	22.98	23.64
10	20175	25	#Max	16QAM	22.89	23.55
10	20175	50	#0	16QAM	22.88	23.54
10	20350	1	#0	QPSK	24.93	25.59
10	20350	1	#Mid	QPSK	25.03	25.69
10	20350	1	#Max	QPSK	25.06	25.72
10	20350	25	#0	QPSK	23.76	24.42
10	20350	25	#Mid	QPSK	23.75	24.41
10	20350	25	#Max	QPSK	23.84	24.50
10	20350	50	#0	QPSK	23.73	24.39
10	20350	1	#0	16QAM	23.65	24.31
10	20350	1	#Mid	16QAM	23.70	24.36
10	20350	1	#Max	16QAM	23.74	24.40
10	20350	25	#0	16QAM	22.76	23.42
10	20350	25	#Mid	16QAM	22.82	23.48
10	20350	25	#Max	16QAM	22.87	23.53
10	20350	50	#0	16QAM	22.80	23.46
15	20025	1	#0	QPSK	25.20	25.86
15	20025	1	#Mid	QPSK	25.50	26.16
15	20025	1	#Max	QPSK	25.36	26.02
15	20025	36	#0	QPSK	24.21	24.87
15	20025	36	#Mid	QPSK	24.20	24.86
15	20025	36	#Max	QPSK	24.35	25.01
15	20025	75	#0	QPSK	24.27	24.93
15	20025	1	#0	16QAM	23.98	24.64
15	20025	1	#Mid	16QAM	24.21	24.87
15	20025	1	#Max	16QAM	24.11	24.77
15	20025	36	#0	16QAM	23.10	23.76
15	20025	36	#Mid	16QAM	23.11	23.77
15	20025	36	#Max	16QAM	23.27	23.93
15	20025	75	#0	16QAM	23.20	23.86
15	20175	1	#0	QPSK	25.05	25.71
15	20175	1	#Mid	QPSK	25.08	25.74
15	20175	1	#Max	QPSK	24.81	25.47
15	20175	36	#0	QPSK	24.12	24.78

15	20175	36	#Mid	QPSK	24.13	24.79
15	20175	36	#Max	QPSK	23.95	24.61
15	20175	75	#0	QPSK	24.08	24.74
15	20175	1	#0	16QAM	24.12	24.78
15	20175	1	#Mid	16QAM	24.18	24.84
15	20175	1	#Max	16QAM	24.01	24.67
15	20175	36	#0	16QAM	23.08	23.74
15	20175	36	#Mid	16QAM	23.09	23.75
15	20175	36	#Max	16QAM	22.92	23.58
15	20175	75	#0	16QAM	23.00	23.66
15	20325	1	#0	QPSK	24.75	25.41
15	20325	1	#Mid	QPSK	24.93	25.59
15	20325	1	#Max	QPSK	24.88	25.54
15	20325	36	#0	QPSK	23.88	24.54
15	20325	36	#Mid	QPSK	23.86	24.52
15	20325	36	#Max	QPSK	23.93	24.59
15	20325	75	#0	QPSK	23.94	24.60
15	20325	1	#0	16QAM	23.88	24.54
15	20325	1	#Mid	16QAM	23.96	24.62
15	20325	1	#Max	16QAM	23.93	24.59
15	20325	36	#0	16QAM	22.78	23.44
15	20325	36	#Mid	16QAM	22.81	23.47
15	20325	36	#Max	16QAM	22.92	23.58
15	20325	75	#0	16QAM	22.87	23.53
20	20050	1	#0	QPSK	25.10	25.76
20	20050	1	#Mid	QPSK	25.47	26.13
20	20050	1	#Max	QPSK	25.17	25.83
20	20050	50	#0	QPSK	23.98	24.64
20	20050	50	#Mid	QPSK	24.02	24.68
20	20050	50	#Max	QPSK	24.09	24.75
20	20050	100	#0	QPSK	24.02	24.68
20	20050	1	#0	16QAM	23.80	24.46
20	20050	1	#Mid	16QAM	24.15	24.81
20	20050	1	#Max	16QAM	23.84	24.50
20	20050	50	#0	16QAM	22.92	23.58
20	20050	50	#Mid	16QAM	22.96	23.62
20	20050	50	#Max	16QAM	23.04	23.70
20	20050	100	#0	16QAM	23.01	23.67
20	20175	1	#0	QPSK	25.09	25.75
20	20175	1	#Mid	QPSK	25.12	25.78
20	20175	1	#Max	QPSK	24.79	25.45
20	20175	50	#0	QPSK	23.99	24.65
20	20175	50	#Mid	QPSK	23.98	24.64

20	20175	50	#Max	QPSK	23.82	24.48
20	20175	100	#0	QPSK	23.95	24.61
20	20175	1	#0	16QAM	23.69	24.35
20	20175	1	#Mid	16QAM	23.75	24.41
20	20175	1	#Max	16QAM	23.47	24.13
20	20175	50	#0	16QAM	23.03	23.69
20	20175	50	#Mid	16QAM	23.02	23.68
20	20175	50	#Max	16QAM	22.87	23.53
20	20175	100	#0	16QAM	22.85	23.51
20	20300	1	#0	QPSK	24.78	25.44
20	20300	1	#Mid	QPSK	24.98	25.64
20	20300	1	#Max	QPSK	24.91	25.57
20	20300	50	#0	QPSK	23.79	24.45
20	20300	50	#Mid	QPSK	23.76	24.42
20	20300	50	#Max	QPSK	23.85	24.51
20	20300	100	#0	QPSK	23.77	24.43
20	20300	1	#0	16QAM	23.89	24.55
20	20300	1	#Mid	16QAM	23.98	24.64
20	20300	1	#Max	16QAM	23.88	24.54
20	20300	50	#0	16QAM	22.74	23.40
20	20300	50	#Mid	16QAM	22.75	23.41
20	20300	50	#Max	16QAM	22.87	23.53
20	20300	100	#0	16QAM	22.80	23.46
1.4	19957	1	#0	64QAM	23.35	24.01
1.4	19957	1	#Mid	64QAM	23.46	24.12
1.4	19957	1	#Max	64QAM	23.46	24.12
1.4	19957	3	#0	64QAM	23.56	24.22
1.4	19957	3	#Mid	64QAM	23.54	24.20
1.4	19957	3	#Max	64QAM	23.62	24.28
1.4	19957	6	#0	64QAM	22.65	23.31
1.4	20175	1	#0	64QAM	23.49	24.15
1.4	20175	1	#Mid	64QAM	23.56	24.22
1.4	20175	1	#Max	64QAM	23.50	24.16
1.4	20175	3	#0	64QAM	23.37	24.03
1.4	20175	3	#Mid	64QAM	23.37	24.03
1.4	20175	3	#Max	64QAM	23.41	24.07
1.4	20175	6	#0	64QAM	22.46	23.12
1.4	20393	1	#0	64QAM	23.16	23.82
1.4	20393	1	#Mid	64QAM	23.20	23.86
1.4	20393	1	#Max	64QAM	23.17	23.83
1.4	20393	3	#0	64QAM	23.23	23.89
1.4	20393	3	#Mid	64QAM	23.25	23.91
1.4	20393	3	#Max	64QAM	23.26	23.92

1.4	20393	6	#0	64QAM	22.48	23.14
3	19965	1	#0	64QAM	23.48	24.14
3	19965	1	#Mid	64QAM	23.60	24.26
3	19965	1	#Max	64QAM	23.52	24.18
3	19965	8	#0	64QAM	22.54	23.20
3	19965	8	#Mid	64QAM	22.51	23.17
3	19965	8	#Max	64QAM	22.58	23.24
3	19965	15	#0	64QAM	22.39	23.05
3	20175	1	#0	64QAM	23.16	23.82
3	20175	1	#Mid	64QAM	23.26	23.92
3	20175	1	#Max	64QAM	23.13	23.79
3	20175	8	#0	64QAM	22.50	23.16
3	20175	8	#Mid	64QAM	22.46	23.12
3	20175	8	#Max	64QAM	22.47	23.13
3	20175	15	#0	64QAM	22.45	23.11
3	20385	1	#0	64QAM	23.33	23.99
3	20385	1	#Mid	64QAM	23.46	24.12
3	20385	1	#Max	64QAM	23.37	24.03
3	20385	8	#0	64QAM	22.38	23.04
3	20385	8	#Mid	64QAM	22.42	23.08
3	20385	8	#Max	64QAM	22.45	23.11
3	20385	15	#0	64QAM	22.42	23.08
5	19975	1	#0	64QAM	24.52	25.18
5	19975	1	#Mid	64QAM	24.72	25.38
5	19975	1	#Max	64QAM	24.65	25.31
5	19975	12	#0	64QAM	23.59	24.25
5	19975	12	#Mid	64QAM	23.58	24.24
5	19975	12	#Max	64QAM	23.67	24.33
5	19975	25	#0	64QAM	23.62	24.28
5	20175	1	#0	64QAM	24.54	25.20
5	20175	1	#Mid	64QAM	24.61	25.27
5	20175	1	#Max	64QAM	24.43	25.09
5	20175	12	#0	64QAM	23.54	24.20
5	20175	12	#Mid	64QAM	23.54	24.20
5	20175	12	#Max	64QAM	23.47	24.13
5	20175	25	#0	64QAM	23.46	24.12
5	20375	1	#0	64QAM	24.42	25.08
5	20375	1	#Mid	64QAM	24.60	25.26
5	20375	1	#Max	64QAM	24.46	25.12
5	20375	12	#0	64QAM	23.43	24.09
5	20375	12	#Mid	64QAM	23.44	24.10
5	20375	12	#Max	64QAM	23.45	24.11
5	20375	25	#0	64QAM	23.36	24.02

10	20000	1	#0	64QAM	23.50	24.16
10	20000	1	#Mid	64QAM	23.61	24.27
10	20000	1	#Max	64QAM	23.71	24.37
10	20000	25	#0	64QAM	22.57	23.23
10	20000	25	#Mid	64QAM	22.57	23.23
10	20000	25	#Max	64QAM	22.76	23.42
10	20000	50	#0	64QAM	22.60	23.26
10	20175	1	#0	64QAM	23.79	24.45
10	20175	1	#Mid	64QAM	23.79	24.45
10	20175	1	#Max	64QAM	23.69	24.35
10	20175	25	#0	64QAM	22.59	23.25
10	20175	25	#Mid	64QAM	22.66	23.32
10	20175	25	#Max	64QAM	22.52	23.18
10	20175	50	#0	64QAM	22.51	23.17
10	20350	1	#0	64QAM	23.50	24.16
10	20350	1	#Mid	64QAM	23.58	24.24
10	20350	1	#Max	64QAM	23.57	24.23
10	20350	25	#0	64QAM	22.37	23.03
10	20350	25	#Mid	64QAM	22.35	23.01
10	20350	25	#Max	64QAM	22.49	23.15
10	20350	50	#0	64QAM	22.40	23.06
15	20025	1	#0	64QAM	23.72	24.38
15	20025	1	#Mid	64QAM	23.94	24.60
15	20025	1	#Max	64QAM	23.86	24.52
15	20025	36	#0	64QAM	22.72	23.38
15	20025	36	#Mid	64QAM	22.70	23.36
15	20025	36	#Max	64QAM	22.91	23.57
15	20025	75	#0	64QAM	22.76	23.42
15	20175	1	#0	64QAM	23.70	24.36
15	20175	1	#Mid	64QAM	23.73	24.39
15	20175	1	#Max	64QAM	23.53	24.19
15	20175	36	#0	64QAM	22.64	23.30
15	20175	36	#Mid	64QAM	22.66	23.32
15	20175	36	#Max	64QAM	22.46	23.12
15	20175	75	#0	64QAM	22.55	23.21
15	20325	1	#0	64QAM	23.36	24.02
15	20325	1	#Mid	64QAM	23.46	24.12
15	20325	1	#Max	64QAM	23.40	24.06
15	20325	36	#0	64QAM	22.35	23.01
15	20325	36	#Mid	64QAM	22.38	23.04
15	20325	36	#Max	64QAM	22.48	23.14
15	20325	75	#0	64QAM	22.45	23.11
20	20050	1	#0	64QAM	23.27	23.93

20	20050	1	#Mid	64QAM	23.61	24.27
20	20050	1	#Max	64QAM	23.27	23.93
20	20050	50	#0	64QAM	22.60	23.26
20	20050	50	#Mid	64QAM	22.61	23.27
20	20050	50	#Max	64QAM	22.75	23.41
20	20050	100	#0	64QAM	22.63	23.29
20	20175	1	#0	64QAM	23.71	24.37
20	20175	1	#Mid	64QAM	23.78	24.44
20	20175	1	#Max	64QAM	23.51	24.17
20	20175	50	#0	64QAM	22.59	23.25
20	20175	50	#Mid	64QAM	22.61	23.27
20	20175	50	#Max	64QAM	22.42	23.08
20	20175	100	#0	64QAM	22.50	23.16
20	20300	1	#0	64QAM	23.22	23.88
20	20300	1	#Mid	64QAM	23.36	24.02
20	20300	1	#Max	64QAM	23.21	23.87
20	20300	50	#0	64QAM	22.32	22.98
20	20300	50	#Mid	64QAM	22.33	22.99
20	20300	50	#Max	64QAM	22.41	23.07
20	20300	100	#0	64QAM	22.42	23.08

LTE Band 7						
Bandwidth (MHz)	UL Channel	RB Size	RB Position	Modulation	Power (dBm)	EIRP (dBm)
5	20775	1	#0	QPSK	24.81	26.81
5	20775	1	#Mid	QPSK	24.94	26.94
5	20775	1	#Max	QPSK	24.82	26.82
5	20775	12	#0	QPSK	23.70	25.70
5	20775	12	#Mid	QPSK	23.70	25.70
5	20775	12	#Max	QPSK	23.71	25.71
5	20775	25	#0	QPSK	23.81	25.81
5	20775	1	#0	16QAM	23.94	25.94
5	20775	1	#Mid	16QAM	24.04	26.04
5	20775	1	#Max	16QAM	23.92	25.92
5	20775	12	#0	16QAM	22.74	24.74
5	20775	12	#Mid	16QAM	22.74	24.74
5	20775	12	#Max	16QAM	22.80	24.80
5	20775	25	#0	16QAM	22.80	24.80
5	21100	1	#0	QPSK	24.38	26.38
5	21100	1	#Mid	QPSK	24.51	26.51
5	21100	1	#Max	QPSK	24.38	26.38
5	21100	12	#0	QPSK	23.44	25.44
5	21100	12	#Mid	QPSK	23.42	25.42

5	21100	12	#Max	QPSK	23.38	25.38
5	21100	25	#0	QPSK	23.36	25.36
5	21100	1	#0	16QAM	23.45	25.45
5	21100	1	#Mid	16QAM	23.57	25.57
5	21100	1	#Max	16QAM	23.43	25.43
5	21100	12	#0	16QAM	22.36	24.36
5	21100	12	#Mid	16QAM	22.32	24.32
5	21100	12	#Max	16QAM	22.28	24.28
5	21100	25	#0	16QAM	22.36	24.36
5	21425	1	#0	QPSK	24.51	26.51
5	21425	1	#Mid	QPSK	24.74	26.74
5	21425	1	#Max	QPSK	24.68	26.68
5	21425	12	#0	QPSK	23.54	25.54
5	21425	12	#Mid	QPSK	23.52	25.52
5	21425	12	#Max	QPSK	23.55	25.55
5	21425	25	#0	QPSK	23.52	25.52
5	21425	1	#0	16QAM	23.60	25.60
5	21425	1	#Mid	16QAM	23.76	25.76
5	21425	1	#Max	16QAM	23.67	25.67
5	21425	12	#0	16QAM	22.48	24.48
5	21425	12	#Mid	16QAM	22.50	24.50
5	21425	12	#Max	16QAM	22.50	24.50
5	21425	25	#0	16QAM	22.52	24.52
10	20800	1	#0	QPSK	24.93	26.93
10	20800	1	#Mid	QPSK	24.92	26.92
10	20800	1	#Max	QPSK	24.95	26.95
10	20800	25	#0	QPSK	23.78	25.78
10	20800	25	#Mid	QPSK	23.78	25.78
10	20800	25	#Max	QPSK	23.86	25.86
10	20800	50	#0	QPSK	23.83	25.83
10	20800	1	#0	16QAM	23.68	25.68
10	20800	1	#Mid	16QAM	23.65	25.65
10	20800	1	#Max	16QAM	23.67	25.67
10	20800	25	#0	16QAM	22.73	24.73
10	20800	25	#Mid	16QAM	22.73	24.73
10	20800	25	#Max	16QAM	22.83	24.83
10	20800	50	#0	16QAM	22.81	24.81
10	21100	1	#0	QPSK	24.41	26.41
10	21100	1	#Mid	QPSK	24.38	26.38
10	21100	1	#Max	QPSK	24.25	26.25
10	21100	25	#0	QPSK	23.45	25.45
10	21100	25	#Mid	QPSK	23.43	25.43
10	21100	25	#Max	QPSK	23.37	25.37

10	21100	50	#0	QPSK	23.41	25.41
10	21100	1	#0	16QAM	23.64	25.64
10	21100	1	#Mid	16QAM	23.59	25.59
10	21100	1	#Max	16QAM	23.55	25.55
10	21100	25	#0	16QAM	22.51	24.51
10	21100	25	#Mid	16QAM	22.52	24.52
10	21100	25	#Max	16QAM	22.40	24.40
10	21100	50	#0	16QAM	22.40	24.40
10	21400	1	#0	QPSK	24.46	26.46
10	21400	1	#Mid	QPSK	24.59	26.59
10	21400	1	#Max	QPSK	24.57	26.57
10	21400	25	#0	QPSK	23.51	25.51
10	21400	25	#Mid	QPSK	23.52	25.52
10	21400	25	#Max	QPSK	23.56	25.56
10	21400	50	#0	QPSK	23.56	25.56
10	21400	1	#0	16QAM	23.61	25.61
10	21400	1	#Mid	16QAM	23.69	25.69
10	21400	1	#Max	16QAM	23.70	25.70
10	21400	25	#0	16QAM	22.48	24.48
10	21400	25	#Mid	16QAM	22.51	24.51
10	21400	25	#Max	16QAM	22.54	24.54
10	21400	50	#0	16QAM	22.51	24.51
15	20825	1	#0	QPSK	24.74	26.74
15	20825	1	#Mid	QPSK	24.83	26.83
15	20825	1	#Max	QPSK	24.77	26.77
15	20825	36	#0	QPSK	23.81	25.81
15	20825	36	#Mid	QPSK	23.83	25.83
15	20825	36	#Max	QPSK	23.94	25.94
15	20825	75	#0	QPSK	23.88	25.88
15	20825	1	#0	16QAM	23.84	25.84
15	20825	1	#Mid	16QAM	23.95	25.95
15	20825	1	#Max	16QAM	23.88	25.88
15	20825	36	#0	16QAM	22.78	24.78
15	20825	36	#Mid	16QAM	22.74	24.74
15	20825	36	#Max	16QAM	22.88	24.88
15	20825	75	#0	16QAM	22.80	24.80
15	21100	1	#0	QPSK	24.43	26.43
15	21100	1	#Mid	QPSK	24.45	26.45
15	21100	1	#Max	QPSK	24.31	26.31
15	21100	36	#0	QPSK	23.55	25.55
15	21100	36	#Mid	QPSK	23.54	25.54
15	21100	36	#Max	QPSK	23.43	25.43
15	21100	75	#0	QPSK	23.54	25.54

15	21100	1	#0	16QAM	23.50	25.50
15	21100	1	#Mid	16QAM	23.53	25.53
15	21100	1	#Max	16QAM	23.37	25.37
15	21100	36	#0	16QAM	22.43	24.43
15	21100	36	#Mid	16QAM	22.46	24.46
15	21100	36	#Max	16QAM	22.35	24.35
15	21100	75	#0	16QAM	22.43	24.43
15	21375	1	#0	QPSK	24.44	26.44
15	21375	1	#Mid	QPSK	24.82	26.82
15	21375	1	#Max	QPSK	24.77	26.77
15	21375	36	#0	QPSK	23.52	25.52
15	21375	36	#Mid	QPSK	23.54	25.54
15	21375	36	#Max	QPSK	23.75	25.75
15	21375	75	#0	QPSK	23.66	25.66
15	21375	1	#0	16QAM	23.26	25.26
15	21375	1	#Mid	16QAM	23.56	25.56
15	21375	1	#Max	16QAM	23.51	25.51
15	21375	36	#0	16QAM	22.41	24.41
15	21375	36	#Mid	16QAM	22.43	24.43
15	21375	36	#Max	16QAM	22.60	24.60
15	21375	75	#0	16QAM	22.54	24.54
20	20850	1	#0	QPSK	24.72	26.72
20	20850	1	#Mid	QPSK	24.91	26.91
20	20850	1	#Max	QPSK	24.81	26.81
20	20850	50	#0	QPSK	23.63	25.63
20	20850	50	#Mid	QPSK	23.66	25.66
20	20850	50	#Max	QPSK	23.83	25.83
20	20850	100	#0	QPSK	23.66	25.66
20	20850	1	#0	16QAM	23.74	25.74
20	20850	1	#Mid	16QAM	23.93	25.93
20	20850	1	#Max	16QAM	23.81	25.81
20	20850	50	#0	16QAM	22.61	24.61
20	20850	50	#Mid	16QAM	22.59	24.59
20	20850	50	#Max	16QAM	22.76	24.76
20	20850	100	#0	16QAM	22.68	24.68
20	21100	1	#0	QPSK	24.50	26.50
20	21100	1	#Mid	QPSK	24.60	26.60
20	21100	1	#Max	QPSK	24.35	26.35
20	21100	50	#0	QPSK	23.48	25.48
20	21100	50	#Mid	QPSK	23.46	25.46
20	21100	50	#Max	QPSK	23.37	25.37
20	21100	100	#0	QPSK	23.39	25.39
20	21100	1	#0	16QAM	23.27	25.27

20	21100	1	#Mid	16QAM	23.33	25.33
20	21100	1	#Max	16QAM	23.07	25.07
20	21100	50	#0	16QAM	22.44	24.44
20	21100	50	#Mid	16QAM	22.43	24.43
20	21100	50	#Max	16QAM	22.31	24.31
20	21100	100	#0	16QAM	22.40	24.40
20	21350	1	#0	QPSK	24.14	26.14
20	21350	1	#Mid	QPSK	24.65	26.65
20	21350	1	#Max	QPSK	24.70	26.70
20	21350	50	#0	QPSK	23.29	25.29
20	21350	50	#Mid	QPSK	23.30	25.30
20	21350	50	#Max	QPSK	23.50	25.50
20	21350	100	#0	QPSK	23.38	25.38
20	21350	1	#0	16QAM	22.83	24.83
20	21350	1	#Mid	16QAM	23.25	25.25
20	21350	1	#Max	16QAM	23.20	25.20
20	21350	50	#0	16QAM	22.29	24.29
20	21350	50	#Mid	16QAM	22.32	24.32
20	21350	50	#Max	16QAM	22.48	24.48
20	21350	100	#0	16QAM	22.35	24.35
5	20775	1	#0	64QAM	24.23	26.23
5	20775	1	#Mid	64QAM	24.35	26.35
5	20775	1	#Max	64QAM	24.19	26.19
5	20775	12	#0	64QAM	23.17	25.17
5	20775	12	#Mid	64QAM	23.15	25.15
5	20775	12	#Max	64QAM	23.15	25.15
5	20775	25	#0	64QAM	23.25	25.25
5	21100	1	#0	64QAM	23.82	25.82
5	21100	1	#Mid	64QAM	23.95	25.95
5	21100	1	#Max	64QAM	23.83	25.83
5	21100	12	#0	64QAM	22.86	24.86
5	21100	12	#Mid	64QAM	22.86	24.86
5	21100	12	#Max	64QAM	22.80	24.80
5	21100	25	#0	64QAM	22.82	24.82
5	21425	1	#0	64QAM	24.10	26.10
5	21425	1	#Mid	64QAM	24.30	26.30
5	21425	1	#Max	64QAM	24.30	26.30
5	21425	12	#0	64QAM	23.01	25.01
5	21425	12	#Mid	64QAM	23.00	25.00
5	21425	12	#Max	64QAM	23.07	25.07
5	21425	25	#0	64QAM	23.02	25.02
10	20800	1	#0	64QAM	23.42	25.42
10	20800	1	#Mid	64QAM	23.43	25.43

10	20800	1	#Max	64QAM	23.41	25.41
10	20800	25	#0	64QAM	22.23	24.23
10	20800	25	#Mid	64QAM	22.24	24.24
10	20800	25	#Max	64QAM	22.35	24.35
10	20800	50	#0	64QAM	22.24	24.24
10	21100	1	#0	64QAM	22.79	24.79
10	21100	1	#Mid	64QAM	22.80	24.80
10	21100	1	#Max	64QAM	22.69	24.69
10	21100	25	#0	64QAM	21.90	23.90
10	21100	25	#Mid	64QAM	21.90	23.90
10	21100	25	#Max	64QAM	21.84	23.84
10	21100	50	#0	64QAM	21.88	23.88
10	21400	1	#0	64QAM	23.12	25.12
10	21400	1	#Mid	64QAM	23.19	25.19
10	21400	1	#Max	64QAM	23.21	25.21
10	21400	25	#0	64QAM	22.03	24.03
10	21400	25	#Mid	64QAM	21.99	23.99
10	21400	25	#Max	64QAM	22.05	24.05
10	21400	50	#0	64QAM	22.01	24.01
15	20825	1	#0	64QAM	23.34	25.34
15	20825	1	#Mid	64QAM	23.43	25.43
15	20825	1	#Max	64QAM	23.36	25.36
15	20825	36	#0	64QAM	22.23	24.23
15	20825	36	#Mid	64QAM	22.21	24.21
15	20825	36	#Max	64QAM	22.35	24.35
15	20825	75	#0	64QAM	22.27	24.27
15	21100	1	#0	64QAM	22.97	24.97
15	21100	1	#Mid	64QAM	23.01	25.01
15	21100	1	#Max	64QAM	22.88	24.88
15	21100	36	#0	64QAM	21.92	23.92
15	21100	36	#Mid	64QAM	21.95	23.95
15	21100	36	#Max	64QAM	21.78	23.78
15	21100	75	#0	64QAM	21.90	23.90
15	21375	1	#0	64QAM	22.74	24.74
15	21375	1	#Mid	64QAM	23.04	25.04
15	21375	1	#Max	64QAM	22.98	24.98
15	21375	36	#0	64QAM	21.91	23.91
15	21375	36	#Mid	64QAM	21.91	23.91
15	21375	36	#Max	64QAM	22.04	24.04
15	21375	75	#0	64QAM	22.02	24.02
20	20850	1	#0	64QAM	23.20	25.20
20	20850	1	#Mid	64QAM	23.39	25.39
20	20850	1	#Max	64QAM	23.25	25.25

20	20850	50	#0	64QAM	22.06	24.06
20	20850	50	#Mid	64QAM	22.08	24.08
20	20850	50	#Max	64QAM	22.23	24.23
20	20850	100	#0	64QAM	22.14	24.14
20	21100	1	#0	64QAM	22.71	24.71
20	21100	1	#Mid	64QAM	22.79	24.79
20	21100	1	#Max	64QAM	22.56	24.56
20	21100	50	#0	64QAM	21.89	23.89
20	21100	50	#Mid	64QAM	21.91	23.91
20	21100	50	#Max	64QAM	21.75	23.75
20	21100	100	#0	64QAM	21.88	23.88
20	21350	1	#0	64QAM	22.33	24.33
20	21350	1	#Mid	64QAM	22.74	24.74
20	21350	1	#Max	64QAM	22.68	24.68
20	21350	50	#0	64QAM	21.79	23.79
20	21350	50	#Mid	64QAM	21.80	23.80
20	21350	50	#Max	64QAM	21.94	23.94
20	21350	100	#0	64QAM	21.84	23.84

LTE Band 12						
Bandwidth (MHz)	UL Channel	RB Size	RB Position	Modulation	Power (dBm)	ERP (dBm)
1.4	23017	1	#0	QPSK	24.77	17.59
1.4	23017	1	#Mid	QPSK	24.83	17.65
1.4	23017	1	#Max	QPSK	24.78	17.60
1.4	23017	3	#0	QPSK	24.68	17.50
1.4	23017	3	#Mid	QPSK	24.68	17.50
1.4	23017	3	#Max	QPSK	24.73	17.55
1.4	23017	6	#0	QPSK	23.83	16.65
1.4	23017	1	#0	16QAM	23.57	16.39
1.4	23017	1	#Mid	16QAM	23.71	16.53
1.4	23017	1	#Max	16QAM	23.62	16.44
1.4	23017	3	#0	16QAM	23.76	16.58
1.4	23017	3	#Mid	16QAM	23.75	16.57
1.4	23017	3	#Max	16QAM	23.82	16.64
1.4	23017	6	#0	16QAM	22.80	15.62
1.4	23095	1	#0	QPSK	24.58	17.40
1.4	23095	1	#Mid	QPSK	24.64	17.46
1.4	23095	1	#Max	QPSK	24.58	17.40
1.4	23095	3	#0	QPSK	24.65	17.47
1.4	23095	3	#Mid	QPSK	24.64	17.46
1.4	23095	3	#Max	QPSK	24.63	17.45
1.4	23095	6	#0	QPSK	23.78	16.60

1.4	23095	1	#0	16QAM	23.70	16.52
1.4	23095	1	#Mid	16QAM	23.77	16.59
1.4	23095	1	#Max	16QAM	23.78	16.60
1.4	23095	3	#0	16QAM	23.61	16.43
1.4	23095	3	#Mid	16QAM	23.60	16.42
1.4	23095	3	#Max	16QAM	23.61	16.43
1.4	23095	6	#0	16QAM	22.68	15.50
1.4	23173	1	#0	QPSK	24.75	17.57
1.4	23173	1	#Mid	QPSK	24.78	17.60
1.4	23173	1	#Max	QPSK	24.81	17.63
1.4	23173	3	#0	QPSK	24.63	17.45
1.4	23173	3	#Mid	QPSK	24.65	17.47
1.4	23173	3	#Max	QPSK	24.57	17.39
1.4	23173	6	#0	QPSK	23.79	16.61
1.4	23173	1	#0	16QAM	23.42	16.24
1.4	23173	1	#Mid	16QAM	23.42	16.24
1.4	23173	1	#Max	16QAM	23.41	16.23
1.4	23173	3	#0	16QAM	23.50	16.32
1.4	23173	3	#Mid	16QAM	23.51	16.33
1.4	23173	3	#Max	16QAM	23.47	16.29
1.4	23173	6	#0	16QAM	22.63	15.45
3	23025	1	#0	QPSK	24.60	17.42
3	23025	1	#Mid	QPSK	24.70	17.52
3	23025	1	#Max	QPSK	24.64	17.46
3	23025	8	#0	QPSK	23.70	16.52
3	23025	8	#Mid	QPSK	23.71	16.53
3	23025	8	#Max	QPSK	23.81	16.63
3	23025	15	#0	QPSK	23.75	16.57
3	23025	1	#0	16QAM	23.26	16.08
3	23025	1	#Mid	16QAM	23.44	16.26
3	23025	1	#Max	16QAM	23.37	16.19
3	23025	8	#0	16QAM	22.71	15.53
3	23025	8	#Mid	16QAM	22.68	15.50
3	23025	8	#Max	16QAM	22.78	15.60
3	23025	15	#0	16QAM	22.68	15.50
3	23095	1	#0	QPSK	24.46	17.28
3	23095	1	#Mid	QPSK	24.59	17.41
3	23095	1	#Max	QPSK	24.44	17.26
3	23095	8	#0	QPSK	23.70	16.52
3	23095	8	#Mid	QPSK	23.71	16.53
3	23095	8	#Max	QPSK	23.69	16.51
3	23095	15	#0	QPSK	23.68	16.50
3	23095	1	#0	16QAM	23.67	16.49

3	23095	1	#Mid	16QAM	23.79	16.61
3	23095	1	#Max	16QAM	23.67	16.49
3	23095	8	#0	16QAM	22.68	15.50
3	23095	8	#Mid	16QAM	22.65	15.47
3	23095	8	#Max	16QAM	22.69	15.51
3	23095	15	#0	16QAM	22.64	15.46
3	23165	1	#0	QPSK	24.42	17.24
3	23165	1	#Mid	QPSK	24.58	17.40
3	23165	1	#Max	QPSK	24.53	17.35
3	23165	8	#0	QPSK	23.62	16.44
3	23165	8	#Mid	QPSK	23.61	16.43
3	23165	8	#Max	QPSK	23.72	16.54
3	23165	15	#0	QPSK	23.61	16.43
3	23165	1	#0	16QAM	23.47	16.29
3	23165	1	#Mid	16QAM	23.59	16.41
3	23165	1	#Max	16QAM	23.47	16.29
3	23165	8	#0	16QAM	22.54	15.36
3	23165	8	#Mid	16QAM	22.58	15.40
3	23165	8	#Max	16QAM	22.63	15.45
3	23165	15	#0	16QAM	22.46	15.28
5	23035	1	#0	QPSK	24.76	17.58
5	23035	1	#Mid	QPSK	24.97	17.79
5	23035	1	#Max	QPSK	24.82	17.64
5	23035	12	#0	QPSK	23.74	16.56
5	23035	12	#Mid	QPSK	23.79	16.61
5	23035	12	#Max	QPSK	23.88	16.70
5	23035	25	#0	QPSK	23.82	16.64
5	23035	1	#0	16QAM	23.90	16.72
5	23035	1	#Mid	16QAM	24.06	16.88
5	23035	1	#Max	16QAM	23.93	16.75
5	23035	12	#0	16QAM	22.67	15.49
5	23035	12	#Mid	16QAM	22.66	15.48
5	23035	12	#Max	16QAM	22.81	15.63
5	23035	25	#0	16QAM	22.74	15.56
5	23095	1	#0	QPSK	24.69	17.51
5	23095	1	#Mid	QPSK	24.84	17.66
5	23095	1	#Max	QPSK	24.68	17.50
5	23095	12	#0	QPSK	23.76	16.58
5	23095	12	#Mid	QPSK	23.75	16.57
5	23095	12	#Max	QPSK	23.68	16.50
5	23095	25	#0	QPSK	23.72	16.54
5	23095	1	#0	16QAM	23.94	16.76
5	23095	1	#Mid	16QAM	24.06	16.88

5	23095	1	#Max	16QAM	23.98	16.80
5	23095	12	#0	16QAM	22.76	15.58
5	23095	12	#Mid	16QAM	22.77	15.59
5	23095	12	#Max	16QAM	22.69	15.51
5	23095	25	#0	16QAM	22.71	15.53
5	23155	1	#0	QPSK	24.71	17.53
5	23155	1	#Mid	QPSK	24.80	17.62
5	23155	1	#Max	QPSK	24.80	17.62
5	23155	12	#0	QPSK	23.64	16.46
5	23155	12	#Mid	QPSK	23.66	16.48
5	23155	12	#Max	QPSK	23.69	16.51
5	23155	25	#0	QPSK	23.68	16.50
5	23155	1	#0	16QAM	23.95	16.77
5	23155	1	#Mid	16QAM	24.01	16.83
5	23155	1	#Max	16QAM	23.88	16.70
5	23155	12	#0	16QAM	22.59	15.41
5	23155	12	#Mid	16QAM	22.60	15.42
5	23155	12	#Max	16QAM	22.61	15.43
5	23155	25	#0	16QAM	22.66	15.48
10	23060	1	#0	QPSK	24.97	17.79
10	23060	1	#Mid	QPSK	24.98	17.80
10	23060	1	#Max	QPSK	24.96	17.78
10	23060	25	#0	QPSK	23.66	16.48
10	23060	25	#Mid	QPSK	23.64	16.46
10	23060	25	#Max	QPSK	23.74	16.56
10	23060	50	#0	QPSK	23.72	16.54
10	23060	1	#0	16QAM	23.67	16.49
10	23060	1	#Mid	16QAM	23.77	16.59
10	23060	1	#Max	16QAM	23.67	16.49
10	23060	25	#0	16QAM	22.62	15.44
10	23060	25	#Mid	16QAM	22.66	15.48
10	23060	25	#Max	16QAM	22.73	15.55
10	23060	50	#0	16QAM	22.65	15.47
10	23095	1	#0	QPSK	24.82	17.64
10	23095	1	#Mid	QPSK	24.86	17.68
10	23095	1	#Max	QPSK	24.78	17.60
10	23095	25	#0	QPSK	23.70	16.52
10	23095	25	#Mid	QPSK	23.72	16.54
10	23095	25	#Max	QPSK	23.71	16.53
10	23095	50	#0	QPSK	23.73	16.55
10	23095	1	#0	16QAM	24.05	16.87
10	23095	1	#Mid	16QAM	24.05	16.87
10	23095	1	#Max	16QAM	24.00	16.82

10	23095	25	#0	16QAM	22.78	15.60
10	23095	25	#Mid	16QAM	22.77	15.59
10	23095	25	#Max	16QAM	22.78	15.60
10	23095	50	#0	16QAM	22.68	15.50
10	23130	1	#0	QPSK	24.83	17.65
10	23130	1	#Mid	QPSK	24.85	17.67
10	23130	1	#Max	QPSK	24.85	17.67
10	23130	25	#0	QPSK	23.81	16.63
10	23130	25	#Mid	QPSK	23.80	16.62
10	23130	25	#Max	QPSK	23.76	16.58
10	23130	50	#0	QPSK	23.80	16.62
10	23130	1	#0	16QAM	23.96	16.78
10	23130	1	#Mid	16QAM	23.98	16.80
10	23130	1	#Max	16QAM	23.86	16.68
10	23130	25	#0	16QAM	22.81	15.63
10	23130	25	#Mid	16QAM	22.85	15.67
10	23130	25	#Max	16QAM	22.80	15.62
10	23130	50	#0	16QAM	22.78	15.60
1.4	23017	1	#0	64QAM	23.33	16.15
1.4	23017	1	#Mid	64QAM	23.40	16.22
1.4	23017	1	#Max	64QAM	23.32	16.14
1.4	23017	3	#0	64QAM	23.43	16.25
1.4	23017	3	#Mid	64QAM	23.44	16.26
1.4	23017	3	#Max	64QAM	23.48	16.30
1.4	23017	6	#0	64QAM	22.49	15.31
1.4	23095	1	#0	64QAM	23.42	16.24
1.4	23095	1	#Mid	64QAM	23.45	16.27
1.4	23095	1	#Max	64QAM	23.43	16.25
1.4	23095	3	#0	64QAM	23.30	16.12
1.4	23095	3	#Mid	64QAM	23.32	16.14
1.4	23095	3	#Max	64QAM	23.30	16.12
1.4	23095	6	#0	64QAM	22.37	15.19
1.4	23173	1	#0	64QAM	23.12	15.94
1.4	23173	1	#Mid	64QAM	23.13	15.95
1.4	23173	1	#Max	64QAM	23.12	15.94
1.4	23173	3	#0	64QAM	23.18	16.00
1.4	23173	3	#Mid	64QAM	23.21	16.03
1.4	23173	3	#Max	64QAM	23.16	15.98
1.4	23173	6	#0	64QAM	22.36	15.18
3	23025	1	#0	64QAM	23.33	16.15
3	23025	1	#Mid	64QAM	23.52	16.34
3	23025	1	#Max	64QAM	23.42	16.24
3	23025	8	#0	64QAM	22.33	15.15

3	23025	8	#Mid	64QAM	22.35	15.17
3	23025	8	#Max	64QAM	22.49	15.31
3	23025	15	#0	64QAM	22.39	15.21
3	23095	1	#0	64QAM	23.24	16.06
3	23095	1	#Mid	64QAM	23.38	16.20
3	23095	1	#Max	64QAM	23.23	16.05
3	23095	8	#0	64QAM	22.37	15.19
3	23095	8	#Mid	64QAM	22.32	15.14
3	23095	8	#Max	64QAM	22.36	15.18
3	23095	15	#0	64QAM	22.26	15.08
3	23165	1	#0	64QAM	22.91	15.73
3	23165	1	#Mid	64QAM	23.03	15.85
3	23165	1	#Max	64QAM	22.94	15.76
3	23165	8	#0	64QAM	22.27	15.09
3	23165	8	#Mid	64QAM	22.25	15.07
3	23165	8	#Max	64QAM	22.35	15.17
3	23165	15	#0	64QAM	22.28	15.10
5	23035	1	#0	64QAM	24.43	17.25
5	23035	1	#Mid	64QAM	24.60	17.42
5	23035	1	#Max	64QAM	24.40	17.22
5	23035	12	#0	64QAM	23.41	16.23
5	23035	12	#Mid	64QAM	23.41	16.23
5	23035	12	#Max	64QAM	23.53	16.35
5	23035	25	#0	64QAM	23.52	16.34
5	23095	1	#0	64QAM	24.48	17.30
5	23095	1	#Mid	64QAM	24.56	17.38
5	23095	1	#Max	64QAM	24.44	17.26
5	23095	12	#0	64QAM	23.43	16.25
5	23095	12	#Mid	64QAM	23.44	16.26
5	23095	12	#Max	64QAM	23.38	16.20
5	23095	25	#0	64QAM	23.42	16.24
5	23155	1	#0	64QAM	24.45	17.27
5	23155	1	#Mid	64QAM	24.54	17.36
5	23155	1	#Max	64QAM	24.57	17.39
5	23155	12	#0	64QAM	23.36	16.18
5	23155	12	#Mid	64QAM	23.34	16.16
5	23155	12	#Max	64QAM	23.42	16.24
5	23155	25	#0	64QAM	23.37	16.19
10	23060	1	#0	64QAM	23.68	16.50
10	23060	1	#Mid	64QAM	23.72	16.54
10	23060	1	#Max	64QAM	23.68	16.50
10	23060	25	#0	64QAM	22.38	15.20
10	23060	25	#Mid	64QAM	22.37	15.19

10	23060	25	#Max	64QAM	22.44	15.26
10	23060	50	#0	64QAM	22.36	15.18
10	23095	1	#0	64QAM	23.36	16.18
10	23095	1	#Mid	64QAM	23.43	16.25
10	23095	1	#Max	64QAM	23.34	16.16
10	23095	25	#0	64QAM	22.44	15.26
10	23095	25	#Mid	64QAM	22.42	15.24
10	23095	25	#Max	64QAM	22.41	15.23
10	23095	50	#0	64QAM	22.37	15.19
10	23130	1	#0	64QAM	23.75	16.57
10	23130	1	#Mid	64QAM	23.74	16.56
10	23130	1	#Max	64QAM	23.59	16.41
10	23130	25	#0	64QAM	22.56	15.38
10	23130	25	#Mid	64QAM	22.56	15.38
10	23130	25	#Max	64QAM	22.54	15.36
10	23130	50	#0	64QAM	22.44	15.26

LTE Band 13						
Bandwidth (MHz)	UL Channel	RB Size	RB Position	Modulation	Power (dBm)	ERP (dBm)
5	23205	1	#0	QPSK	25.00	17.82
5	23205	1	#Mid	QPSK	25.14	17.96
5	23205	1	#Max	QPSK	25.00	17.82
5	23205	12	#0	QPSK	23.88	16.70
5	23205	12	#Mid	QPSK	23.87	16.69
5	23205	12	#Max	QPSK	24.00	16.82
5	23205	25	#0	QPSK	23.93	16.75
5	23205	1	#0	16QAM	24.15	16.97
5	23205	1	#Mid	16QAM	24.28	17.10
5	23205	1	#Max	16QAM	24.15	16.97
5	23205	12	#0	16QAM	22.86	15.68
5	23205	12	#Mid	16QAM	22.82	15.64
5	23205	12	#Max	16QAM	22.93	15.75
5	23205	25	#0	16QAM	22.95	15.77
5	23230	1	#0	QPSK	25.03	17.85
5	23230	1	#Mid	QPSK	25.23	18.05
5	23230	1	#Max	QPSK	25.03	17.85
5	23230	12	#0	QPSK	23.96	16.78
5	23230	12	#Mid	QPSK	23.98	16.80
5	23230	12	#Max	QPSK	24.01	16.83
5	23230	25	#0	QPSK	23.94	16.76
5	23230	1	#0	16QAM	24.08	16.90
5	23230	1	#Mid	16QAM	24.20	17.02

5	23230	1	#Max	16QAM	24.06	16.88
5	23230	12	#0	16QAM	22.86	15.68
5	23230	12	#Mid	16QAM	22.86	15.68
5	23230	12	#Max	16QAM	22.87	15.69
5	23230	25	#0	16QAM	22.89	15.71
5	23255	1	#0	QPSK	24.97	17.79
5	23255	1	#Mid	QPSK	25.10	17.92
5	23255	1	#Max	QPSK	24.95	17.77
5	23255	12	#0	QPSK	24.00	16.82
5	23255	12	#Mid	QPSK	23.99	16.81
5	23255	12	#Max	QPSK	23.99	16.81
5	23255	25	#0	QPSK	23.98	16.80
5	23255	1	#0	16QAM	24.16	16.98
5	23255	1	#Mid	16QAM	24.25	17.07
5	23255	1	#Max	16QAM	24.12	16.94
5	23255	12	#0	16QAM	22.97	15.79
5	23255	12	#Mid	16QAM	22.96	15.78
5	23255	12	#Max	16QAM	22.97	15.79
5	23255	25	#0	16QAM	22.97	15.79
10	23230	1	#0	QPSK	25.10	17.92
10	23230	1	#Mid	QPSK	25.10	17.92
10	23230	1	#Max	QPSK	25.05	17.87
10	23230	25	#0	QPSK	23.84	16.66
10	23230	25	#Mid	QPSK	23.83	16.65
10	23230	25	#Max	QPSK	23.93	16.75
10	23230	50	#0	QPSK	23.88	16.70
10	23230	1	#0	16QAM	24.22	17.04
10	23230	1	#Mid	16QAM	24.25	17.07
10	23230	1	#Max	16QAM	24.22	17.04
10	23230	25	#0	16QAM	22.86	15.68
10	23230	25	#Mid	16QAM	22.85	15.67
10	23230	25	#Max	16QAM	22.97	15.79
10	23230	50	#0	16QAM	22.81	15.63
5	23205	1	#0	64QAM	24.76	17.58
5	23205	1	#Mid	64QAM	24.88	17.70
5	23205	1	#Max	64QAM	24.73	17.55
5	23205	12	#0	64QAM	23.63	16.45
5	23205	12	#Mid	64QAM	23.64	16.46
5	23205	12	#Max	64QAM	23.71	16.53
5	23205	25	#0	64QAM	23.67	16.49
5	23230	1	#0	64QAM	24.66	17.48
5	23230	1	#Mid	64QAM	24.78	17.60
5	23230	1	#Max	64QAM	24.62	17.44

5	23230	12	#0	64QAM	23.64	16.46
5	23230	12	#Mid	64QAM	23.62	16.44
5	23230	12	#Max	64QAM	23.67	16.49
5	23230	25	#0	64QAM	23.62	16.44
5	23255	1	#0	64QAM	24.72	17.54
5	23255	1	#Mid	64QAM	24.83	17.65
5	23255	1	#Max	64QAM	24.70	17.52
5	23255	12	#0	64QAM	23.70	16.52
5	23255	12	#Mid	64QAM	23.72	16.54
5	23255	12	#Max	64QAM	23.69	16.51
5	23255	25	#0	64QAM	23.68	16.50
10	23230	1	#0	64QAM	23.63	16.45
10	23230	1	#Mid	64QAM	23.64	16.46
10	23230	1	#Max	64QAM	23.61	16.43
10	23230	25	#0	64QAM	22.51	15.33
10	23230	25	#Mid	64QAM	22.52	15.34
10	23230	25	#Max	64QAM	22.64	15.46
10	23230	50	#0	64QAM	22.52	15.34

LTE Band 17						
Bandwidth (MHz)	UL Channel	RB Size	RB Position	Modulation	Power (dBm)	ERP (dBm)
5	23755	1	#0	QPSK	24.70	17.52
5	23755	1	#Mid	QPSK	24.84	17.66
5	23755	1	#Max	QPSK	24.66	17.48
5	23755	12	#0	QPSK	23.64	16.46
5	23755	12	#Mid	QPSK	23.65	16.47
5	23755	12	#Max	QPSK	23.63	16.45
5	23755	25	#0	QPSK	23.63	16.45
5	23755	1	#0	16QAM	23.91	16.73
5	23755	1	#Mid	16QAM	24.05	16.87
5	23755	1	#Max	16QAM	23.90	16.72
5	23755	12	#0	16QAM	22.65	15.47
5	23755	12	#Mid	16QAM	22.63	15.45
5	23755	12	#Max	16QAM	22.62	15.44
5	23755	25	#0	16QAM	22.65	15.47
5	23790	1	#0	QPSK	24.66	17.48
5	23790	1	#Mid	QPSK	24.79	17.61
5	23790	1	#Max	QPSK	24.61	17.43
5	23790	12	#0	QPSK	23.71	16.53
5	23790	12	#Mid	QPSK	23.68	16.50
5	23790	12	#Max	QPSK	23.72	16.54
5	23790	25	#0	QPSK	23.67	16.49

5	23790	1	#0	16QAM	23.80	16.62
5	23790	1	#Mid	16QAM	23.95	16.77
5	23790	1	#Max	16QAM	23.78	16.60
5	23790	12	#0	16QAM	22.64	15.46
5	23790	12	#Mid	16QAM	22.65	15.47
5	23790	12	#Max	16QAM	22.60	15.42
5	23790	25	#0	16QAM	22.64	15.46
5	23825	1	#0	QPSK	24.61	17.43
5	23825	1	#Mid	QPSK	24.71	17.53
5	23825	1	#Max	QPSK	24.56	17.38
5	23825	12	#0	QPSK	23.56	16.38
5	23825	12	#Mid	QPSK	23.60	16.42
5	23825	12	#Max	QPSK	23.61	16.43
5	23825	25	#0	QPSK	23.60	16.42
5	23825	1	#0	16QAM	23.87	16.69
5	23825	1	#Mid	16QAM	23.91	16.73
5	23825	1	#Max	16QAM	23.77	16.59
5	23825	12	#0	16QAM	22.60	15.42
5	23825	12	#Mid	16QAM	22.58	15.40
5	23825	12	#Max	16QAM	22.65	15.47
5	23825	25	#0	16QAM	22.62	15.44
10	23780	1	#0	QPSK	24.79	17.61
10	23780	1	#Mid	QPSK	24.76	17.58
10	23780	1	#Max	QPSK	24.70	17.52
10	23780	25	#0	QPSK	23.70	16.52
10	23780	25	#Mid	QPSK	23.67	16.49
10	23780	25	#Max	QPSK	23.69	16.51
10	23780	50	#0	QPSK	23.72	16.54
10	23780	1	#0	16QAM	23.98	16.80
10	23780	1	#Mid	16QAM	23.96	16.78
10	23780	1	#Max	16QAM	23.88	16.70
10	23780	25	#0	16QAM	22.75	15.57
10	23780	25	#Mid	16QAM	22.78	15.60
10	23780	25	#Max	16QAM	22.73	15.55
10	23780	50	#0	16QAM	22.63	15.45
10	23790	1	#0	QPSK	24.71	17.53
10	23790	1	#Mid	QPSK	24.78	17.60
10	23790	1	#Max	QPSK	24.72	17.54
10	23790	25	#0	QPSK	23.71	16.53
10	23790	25	#Mid	QPSK	23.71	16.53
10	23790	25	#Max	QPSK	23.71	16.53
10	23790	50	#0	QPSK	23.70	16.52
10	23790	1	#0	16QAM	23.84	16.66

10	23790	1	#Mid	16QAM	23.91	16.73
10	23790	1	#Max	16QAM	23.83	16.65
10	23790	25	#0	16QAM	22.74	15.56
10	23790	25	#Mid	16QAM	22.74	15.56
10	23790	25	#Max	16QAM	22.75	15.57
10	23790	50	#0	16QAM	22.63	15.45
10	23800	1	#0	QPSK	24.87	17.69
10	23800	1	#Mid	QPSK	24.85	17.67
10	23800	1	#Max	QPSK	24.81	17.63
10	23800	25	#0	QPSK	23.69	16.51
10	23800	25	#Mid	QPSK	23.70	16.52
10	23800	25	#Max	QPSK	23.68	16.50
10	23800	50	#0	QPSK	23.69	16.51
10	23800	1	#0	16QAM	23.62	16.44
10	23800	1	#Mid	16QAM	23.65	16.47
10	23800	1	#Max	16QAM	23.48	16.30
10	23800	25	#0	16QAM	22.67	15.49
10	23800	25	#Mid	16QAM	22.72	15.54
10	23800	25	#Max	16QAM	22.66	15.48
10	23800	50	#0	16QAM	22.65	15.47
5	23755	1	#0	64QAM	24.37	17.19
5	23755	1	#Mid	64QAM	24.52	17.34
5	23755	1	#Max	64QAM	24.37	17.19
5	23755	12	#0	64QAM	23.37	16.19
5	23755	12	#Mid	64QAM	23.33	16.15
5	23755	12	#Max	64QAM	23.36	16.18
5	23755	25	#0	64QAM	23.32	16.14
5	23790	1	#0	64QAM	24.28	17.10
5	23790	1	#Mid	64QAM	24.44	17.26
5	23790	1	#Max	64QAM	24.22	17.04
5	23790	12	#0	64QAM	23.34	16.16
5	23790	12	#Mid	64QAM	23.33	16.15
5	23790	12	#Max	64QAM	23.41	16.23
5	23790	25	#0	64QAM	23.33	16.15
5	23825	1	#0	64QAM	24.35	17.17
5	23825	1	#Mid	64QAM	24.42	17.24
5	23825	1	#Max	64QAM	24.32	17.14
5	23825	12	#0	64QAM	23.27	16.09
5	23825	12	#Mid	64QAM	23.22	16.04
5	23825	12	#Max	64QAM	23.29	16.11
5	23825	25	#0	64QAM	23.30	16.12
10	23780	1	#0	64QAM	23.64	16.46
10	23780	1	#Mid	64QAM	23.67	16.49

10	23780	1	#Max	64QAM	23.62	16.44
10	23780	25	#0	64QAM	22.43	15.25
10	23780	25	#Mid	64QAM	22.44	15.26
10	23780	25	#Max	64QAM	22.44	15.26
10	23780	50	#0	64QAM	22.34	15.16
10	23790	1	#0	64QAM	23.58	16.40
10	23790	1	#Mid	64QAM	23.59	16.41
10	23790	1	#Max	64QAM	23.49	16.31
10	23790	25	#0	64QAM	22.44	15.26
10	23790	25	#Mid	64QAM	22.45	15.27
10	23790	25	#Max	64QAM	22.43	15.25
10	23790	50	#0	64QAM	22.35	15.17
10	23800	1	#0	64QAM	23.31	16.13
10	23800	1	#Mid	64QAM	23.34	16.16
10	23800	1	#Max	64QAM	23.20	16.02
10	23800	25	#0	64QAM	22.42	15.24
10	23800	25	#Mid	64QAM	22.44	15.26
10	23800	25	#Max	64QAM	22.36	15.18
10	23800	50	#0	64QAM	22.35	15.17

LTE Band 38						
Bandwidth (MHz)	UL Channel	RB Size	RB Position	Modulation	Power (dBm)	EIRP (dBm)
5	37775	1	#0	QPSK	24.76	23.30
5	37775	1	#Mid	QPSK	24.89	23.43
5	37775	1	#Max	QPSK	24.69	23.23
5	37775	12	#0	QPSK	23.73	22.27
5	37775	12	#Mid	QPSK	23.74	22.28
5	37775	12	#Max	QPSK	23.72	22.26
5	37775	25	#0	QPSK	23.75	22.29
5	37775	1	#0	16QAM	23.82	22.36
5	37775	1	#Mid	16QAM	23.92	22.46
5	37775	1	#Max	16QAM	23.73	22.27
5	37775	12	#0	16QAM	22.74	21.28
5	37775	12	#Mid	16QAM	22.74	21.28
5	37775	12	#Max	16QAM	22.72	21.26
5	37775	25	#0	16QAM	22.76	21.30
5	38000	1	#0	QPSK	24.49	23.03
5	38000	1	#Mid	QPSK	24.66	23.20
5	38000	1	#Max	QPSK	24.61	23.15
5	38000	12	#0	QPSK	23.45	21.99
5	38000	12	#Mid	QPSK	23.43	21.97
5	38000	12	#Max	QPSK	23.53	22.07

5	38000	25	#0	QPSK	23.47	22.01
5	38000	1	#0	16QAM	23.67	22.21
5	38000	1	#Mid	16QAM	23.80	22.34
5	38000	1	#Max	16QAM	23.75	22.29
5	38000	12	#0	16QAM	22.39	20.93
5	38000	12	#Mid	16QAM	22.37	20.91
5	38000	12	#Max	16QAM	22.43	20.97
5	38000	25	#0	16QAM	22.52	21.06
5	38225	1	#0	QPSK	24.70	23.24
5	38225	1	#Mid	QPSK	24.88	23.42
5	38225	1	#Max	QPSK	24.74	23.28
5	38225	12	#0	QPSK	23.65	22.19
5	38225	12	#Mid	QPSK	23.66	22.20
5	38225	12	#Max	QPSK	23.66	22.20
5	38225	25	#0	QPSK	23.63	22.17
5	38225	1	#0	16QAM	23.59	22.13
5	38225	1	#Mid	16QAM	23.73	22.27
5	38225	1	#Max	16QAM	23.59	22.13
5	38225	12	#0	16QAM	22.52	21.06
5	38225	12	#Mid	16QAM	22.54	21.08
5	38225	12	#Max	16QAM	22.57	21.11
5	38225	25	#0	16QAM	22.61	21.15
10	37800	1	#0	QPSK	24.92	23.46
10	37800	1	#Mid	QPSK	24.84	23.38
10	37800	1	#Max	QPSK	24.73	23.27
10	37800	25	#0	QPSK	23.80	22.34
10	37800	25	#Mid	QPSK	23.77	22.31
10	37800	25	#Max	QPSK	23.71	22.25
10	37800	50	#0	QPSK	23.78	22.32
10	37800	1	#0	16QAM	23.56	22.10
10	37800	1	#Mid	16QAM	23.44	21.98
10	37800	1	#Max	16QAM	23.40	21.94
10	37800	25	#0	16QAM	22.76	21.30
10	37800	25	#Mid	16QAM	22.75	21.29
10	37800	25	#Max	16QAM	22.70	21.24
10	37800	50	#0	16QAM	22.78	21.32
10	38000	1	#0	QPSK	24.50	23.04
10	38000	1	#Mid	QPSK	24.56	23.10
10	38000	1	#Max	QPSK	24.67	23.21
10	38000	25	#0	QPSK	23.45	21.99
10	38000	25	#Mid	QPSK	23.45	21.99
10	38000	25	#Max	QPSK	23.56	22.10
10	38000	50	#0	QPSK	23.54	22.08

10	38000	1	#0	16QAM	23.62	22.16
10	38000	1	#Mid	16QAM	23.69	22.23
10	38000	1	#Max	16QAM	23.77	22.31
10	38000	25	#0	16QAM	22.53	21.07
10	38000	25	#Mid	16QAM	22.55	21.09
10	38000	25	#Max	16QAM	22.63	21.17
10	38000	50	#0	16QAM	22.55	21.09
10	38200	1	#0	QPSK	24.75	23.29
10	38200	1	#Mid	QPSK	24.73	23.27
10	38200	1	#Max	QPSK	24.74	23.28
10	38200	25	#0	QPSK	23.69	22.23
10	38200	25	#Mid	QPSK	23.68	22.22
10	38200	25	#Max	QPSK	23.67	22.21
10	38200	50	#0	QPSK	23.70	22.24
10	38200	1	#0	16QAM	23.65	22.19
10	38200	1	#Mid	16QAM	23.61	22.15
10	38200	1	#Max	16QAM	23.65	22.19
10	38200	25	#0	16QAM	22.68	21.22
10	38200	25	#Mid	16QAM	22.68	21.22
10	38200	25	#Max	16QAM	22.65	21.19
10	38200	50	#0	16QAM	22.67	21.21
15	37825	1	#0	QPSK	24.84	23.38
15	37825	1	#Mid	QPSK	24.83	23.37
15	37825	1	#Max	QPSK	24.65	23.19
15	37825	36	#0	QPSK	23.90	22.44
15	37825	36	#Mid	QPSK	23.88	22.42
15	37825	36	#Max	QPSK	23.76	22.30
15	37825	75	#0	QPSK	23.79	22.33
15	37825	1	#0	16QAM	23.73	22.27
15	37825	1	#Mid	16QAM	23.72	22.26
15	37825	1	#Max	16QAM	23.49	22.03
15	37825	36	#0	16QAM	22.78	21.32
15	37825	36	#Mid	16QAM	22.77	21.31
15	37825	36	#Max	16QAM	22.67	21.21
15	37825	75	#0	16QAM	22.73	21.27
15	38000	1	#0	QPSK	24.64	23.18
15	38000	1	#Mid	QPSK	24.76	23.30
15	38000	1	#Max	QPSK	24.84	23.38
15	38000	36	#0	QPSK	23.58	22.12
15	38000	36	#Mid	QPSK	23.55	22.09
15	38000	36	#Max	QPSK	23.71	22.25
15	38000	75	#0	QPSK	23.67	22.21
15	38000	1	#0	16QAM	23.29	21.83

15	38000	1	#Mid	16QAM	23.41	21.95
15	38000	1	#Max	16QAM	23.43	21.97
15	38000	36	#0	16QAM	22.44	20.98
15	38000	36	#Mid	16QAM	22.46	21.00
15	38000	36	#Max	16QAM	22.58	21.12
15	38000	75	#0	16QAM	22.60	21.14
15	38175	1	#0	QPSK	24.67	23.21
15	38175	1	#Mid	QPSK	24.86	23.40
15	38175	1	#Max	QPSK	24.73	23.27
15	38175	36	#0	QPSK	23.77	22.31
15	38175	36	#Mid	QPSK	23.78	22.32
15	38175	36	#Max	QPSK	23.85	22.39
15	38175	75	#0	QPSK	23.83	22.37
15	38175	1	#0	16QAM	23.72	22.26
15	38175	1	#Mid	16QAM	23.87	22.41
15	38175	1	#Max	16QAM	23.75	22.29
15	38175	36	#0	16QAM	22.68	21.22
15	38175	36	#Mid	16QAM	22.66	21.20
15	38175	36	#Max	16QAM	22.74	21.28
15	38175	75	#0	16QAM	22.76	21.30
20	37850	1	#0	QPSK	24.79	23.33
20	37850	1	#Mid	QPSK	24.82	23.36
20	37850	1	#Max	QPSK	24.59	23.13
20	37850	50	#0	QPSK	23.67	22.21
20	37850	50	#Mid	QPSK	23.67	22.21
20	37850	50	#Max	QPSK	23.59	22.13
20	37850	100	#0	QPSK	23.58	22.12
20	37850	1	#0	16QAM	23.72	22.26
20	37850	1	#Mid	16QAM	23.69	22.23
20	37850	1	#Max	16QAM	23.48	22.02
20	37850	50	#0	16QAM	22.66	21.20
20	37850	50	#Mid	16QAM	22.66	21.20
20	37850	50	#Max	16QAM	22.59	21.13
20	37850	100	#0	16QAM	22.60	21.14
20	38000	1	#0	QPSK	24.56	23.10
20	38000	1	#Mid	QPSK	24.73	23.27
20	38000	1	#Max	QPSK	24.78	23.32
20	38000	50	#0	QPSK	23.43	21.97
20	38000	50	#Mid	QPSK	23.43	21.97
20	38000	50	#Max	QPSK	23.59	22.13
20	38000	100	#0	QPSK	23.50	22.04
20	38000	1	#0	16QAM	23.06	21.60
20	38000	1	#Mid	16QAM	23.25	21.79

20	38000	1	#Max	16QAM	23.33	21.87
20	38000	50	#0	16QAM	22.41	20.95
20	38000	50	#Mid	16QAM	22.41	20.95
20	38000	50	#Max	16QAM	22.57	21.11
20	38000	100	#0	16QAM	22.50	21.04
20	38150	1	#0	QPSK	24.42	22.96
20	38150	1	#Mid	QPSK	24.80	23.34
20	38150	1	#Max	QPSK	24.55	23.09
20	38150	50	#0	QPSK	23.59	22.13
20	38150	50	#Mid	QPSK	23.59	22.13
20	38150	50	#Max	QPSK	23.68	22.22
20	38150	100	#0	QPSK	23.60	22.14
20	38150	1	#0	16QAM	22.95	21.49
20	38150	1	#Mid	16QAM	23.30	21.84
20	38150	1	#Max	16QAM	23.06	21.60
20	38150	50	#0	16QAM	22.64	21.18
20	38150	50	#Mid	16QAM	22.62	21.16
20	38150	50	#Max	16QAM	22.69	21.23
20	38150	100	#0	16QAM	22.60	21.14
5	37775	1	#0	64QAM	24.25	22.79
5	37775	1	#Mid	64QAM	24.33	22.87
5	37775	1	#Max	64QAM	24.16	22.70
5	37775	12	#0	64QAM	23.22	21.76
5	37775	12	#Mid	64QAM	23.22	21.76
5	37775	12	#Max	64QAM	23.19	21.73
5	37775	25	#0	64QAM	23.22	21.76
5	38000	1	#0	64QAM	23.95	22.49
5	38000	1	#Mid	64QAM	24.12	22.66
5	38000	1	#Max	64QAM	24.08	22.62
5	38000	12	#0	64QAM	22.91	21.45
5	38000	12	#Mid	64QAM	22.91	21.45
5	38000	12	#Max	64QAM	22.99	21.53
5	38000	25	#0	64QAM	22.94	21.48
5	38225	1	#0	64QAM	24.18	22.72
5	38225	1	#Mid	64QAM	24.37	22.91
5	38225	1	#Max	64QAM	24.21	22.75
5	38225	12	#0	64QAM	23.12	21.66
5	38225	12	#Mid	64QAM	23.12	21.66
5	38225	12	#Max	64QAM	23.13	21.67
5	38225	25	#0	64QAM	23.11	21.65
10	37800	1	#0	64QAM	23.33	21.87
10	37800	1	#Mid	64QAM	23.21	21.75
10	37800	1	#Max	64QAM	23.14	21.68

10	37800	25	#0	64QAM	22.26	20.80
10	37800	25	#Mid	64QAM	22.27	20.81
10	37800	25	#Max	64QAM	22.18	20.72
10	37800	50	#0	64QAM	22.24	20.78
10	38000	1	#0	64QAM	22.63	21.17
10	38000	1	#Mid	64QAM	22.66	21.20
10	38000	1	#Max	64QAM	22.82	21.36
10	38000	25	#0	64QAM	21.93	20.47
10	38000	25	#Mid	64QAM	21.94	20.48
10	38000	25	#Max	64QAM	22.03	20.57
10	38000	50	#0	64QAM	22.02	20.56
10	38200	1	#0	64QAM	23.31	21.85
10	38200	1	#Mid	64QAM	23.28	21.82
10	38200	1	#Max	64QAM	23.28	21.82
10	38200	25	#0	64QAM	22.22	20.76
10	38200	25	#Mid	64QAM	22.23	20.77
10	38200	25	#Max	64QAM	22.20	20.74
10	38200	50	#0	64QAM	22.16	20.70
15	37825	1	#0	64QAM	23.39	21.93
15	37825	1	#Mid	64QAM	23.38	21.92
15	37825	1	#Max	64QAM	23.18	21.72
15	37825	36	#0	64QAM	22.26	20.80
15	37825	36	#Mid	64QAM	22.26	20.80
15	37825	36	#Max	64QAM	22.17	20.71
15	37825	75	#0	64QAM	22.21	20.75
15	38000	1	#0	64QAM	22.81	21.35
15	38000	1	#Mid	64QAM	22.94	21.48
15	38000	1	#Max	64QAM	23.01	21.55
15	38000	36	#0	64QAM	21.95	20.49
15	38000	36	#Mid	64QAM	21.97	20.51
15	38000	36	#Max	64QAM	22.13	20.67
15	38000	75	#0	64QAM	22.05	20.59
15	38175	1	#0	64QAM	22.94	21.48
15	38175	1	#Mid	64QAM	23.08	21.62
15	38175	1	#Max	64QAM	22.99	21.53
15	38175	36	#0	64QAM	22.15	20.69
15	38175	36	#Mid	64QAM	22.11	20.65
15	38175	36	#Max	64QAM	22.17	20.71
15	38175	75	#0	64QAM	22.24	20.78
20	37850	1	#0	64QAM	22.69	21.23
20	37850	1	#Mid	64QAM	22.69	21.23
20	37850	1	#Max	64QAM	22.48	21.02
20	37850	50	#0	64QAM	22.15	20.69

20	37850	50	#Mid	64QAM	22.14	20.68
20	37850	50	#Max	64QAM	22.09	20.63
20	37850	100	#0	64QAM	22.10	20.64
20	38000	1	#0	64QAM	22.86	21.40
20	38000	1	#Mid	64QAM	23.03	21.57
20	38000	1	#Max	64QAM	23.09	21.63
20	38000	50	#0	64QAM	21.92	20.46
20	38000	50	#Mid	64QAM	21.92	20.46
20	38000	50	#Max	64QAM	22.09	20.63
20	38000	100	#0	64QAM	21.96	20.50
20	38150	1	#0	64QAM	22.62	21.16
20	38150	1	#Mid	64QAM	22.94	21.48
20	38150	1	#Max	64QAM	22.75	21.29
20	38150	50	#0	64QAM	22.06	20.60
20	38150	50	#Mid	64QAM	22.05	20.59
20	38150	50	#Max	64QAM	22.12	20.66
20	38150	100	#0	64QAM	22.10	20.64

LTE Band 41						
Bandwidth (MHz)	UL Channel	RB Size	RB Position	Modulation	Power (dBm)	EIRP (dBm)
5	39675	1	#0	QPSK	25.16	23.90
5	39675	1	#Mid	QPSK	25.27	24.01
5	39675	1	#Max	QPSK	25.14	23.88
5	39675	12	#0	QPSK	24.01	22.75
5	39675	12	#Mid	QPSK	24.00	22.74
5	39675	12	#Max	QPSK	24.01	22.75
5	39675	25	#0	QPSK	24.06	22.80
5	39675	1	#0	16QAM	24.03	22.77
5	39675	1	#Mid	16QAM	24.16	22.90
5	39675	1	#Max	16QAM	24.03	22.77
5	39675	12	#0	16QAM	22.97	21.71
5	39675	12	#Mid	16QAM	22.97	21.71
5	39675	12	#Max	16QAM	23.00	21.74
5	39675	25	#0	16QAM	23.00	21.74
5	40620	1	#0	QPSK	24.46	23.20
5	40620	1	#Mid	QPSK	24.55	23.29
5	40620	1	#Max	QPSK	24.50	23.24
5	40620	12	#0	QPSK	23.43	22.17
5	40620	12	#Mid	QPSK	23.45	22.19
5	40620	12	#Max	QPSK	23.46	22.20
5	40620	25	#0	QPSK	23.43	22.17
5	40620	1	#0	16QAM	23.51	22.25

5	40620	1	#Mid	16QAM	23.59	22.33
5	40620	1	#Max	16QAM	23.49	22.23
5	40620	12	#0	16QAM	22.45	21.19
5	40620	12	#Mid	16QAM	22.43	21.17
5	40620	12	#Max	16QAM	22.43	21.17
5	40620	25	#0	16QAM	22.47	21.21
5	41565	1	#0	QPSK	25.03	23.77
5	41565	1	#Mid	QPSK	25.24	23.98
5	41565	1	#Max	QPSK	25.17	23.91
5	41565	12	#0	QPSK	23.89	22.63
5	41565	12	#Mid	QPSK	23.89	22.63
5	41565	12	#Max	QPSK	23.90	22.64
5	41565	25	#0	QPSK	23.85	22.59
5	41565	1	#0	16QAM	24.01	22.75
5	41565	1	#Mid	16QAM	24.16	22.90
5	41565	1	#Max	16QAM	24.10	22.84
5	41565	12	#0	16QAM	22.73	21.47
5	41565	12	#Mid	16QAM	22.74	21.48
5	41565	12	#Max	16QAM	22.75	21.49
5	41565	25	#0	16QAM	22.76	21.50
10	39700	1	#0	QPSK	25.21	23.95
10	39700	1	#Mid	QPSK	25.19	23.93
10	39700	1	#Max	QPSK	25.14	23.88
10	39700	25	#0	QPSK	23.97	22.71
10	39700	25	#Mid	QPSK	23.96	22.70
10	39700	25	#Max	QPSK	24.00	22.74
10	39700	50	#0	QPSK	24.08	22.82
10	39700	1	#0	16QAM	24.00	22.74
10	39700	1	#Mid	16QAM	23.97	22.71
10	39700	1	#Max	16QAM	23.92	22.66
10	39700	25	#0	16QAM	23.04	21.78
10	39700	25	#Mid	16QAM	23.04	21.78
10	39700	25	#Max	16QAM	23.08	21.82
10	39700	50	#0	16QAM	23.01	21.75
10	40620	1	#0	QPSK	24.54	23.28
10	40620	1	#Mid	QPSK	24.51	23.25
10	40620	1	#Max	QPSK	24.63	23.37
10	40620	25	#0	QPSK	23.44	22.18
10	40620	25	#Mid	QPSK	23.44	22.18
10	40620	25	#Max	QPSK	23.49	22.23
10	40620	50	#0	QPSK	23.50	22.24
10	40620	1	#0	16QAM	23.20	21.94
10	40620	1	#Mid	16QAM	23.17	21.91

10	40620	1	#Max	16QAM	23.30	22.04
10	40620	25	#0	16QAM	22.47	21.21
10	40620	25	#Mid	16QAM	22.47	21.21
10	40620	25	#Max	16QAM	22.51	21.25
10	40620	50	#0	16QAM	22.50	21.24
10	41540	1	#0	QPSK	25.12	23.86
10	41540	1	#Mid	QPSK	25.22	23.96
10	41540	1	#Max	QPSK	25.15	23.89
10	41540	25	#0	QPSK	23.89	22.63
10	41540	25	#Mid	QPSK	23.90	22.64
10	41540	25	#Max	QPSK	23.94	22.68
10	41540	50	#0	QPSK	23.84	22.58
10	41540	1	#0	16QAM	23.92	22.66
10	41540	1	#Mid	16QAM	24.00	22.74
10	41540	1	#Max	16QAM	24.06	22.80
10	41540	25	#0	16QAM	22.83	21.57
10	41540	25	#Mid	16QAM	22.84	21.58
10	41540	25	#Max	16QAM	22.86	21.60
10	41540	50	#0	16QAM	22.78	21.52
15	39725	1	#0	QPSK	25.28	24.02
15	39725	1	#Mid	QPSK	25.36	24.10
15	39725	1	#Max	QPSK	25.19	23.93
15	39725	36	#0	QPSK	24.08	22.82
15	39725	36	#Mid	QPSK	24.07	22.81
15	39725	36	#Max	QPSK	24.08	22.82
15	39725	75	#0	QPSK	24.19	22.93
15	39725	1	#0	16QAM	23.87	22.61
15	39725	1	#Mid	16QAM	23.94	22.68
15	39725	1	#Max	16QAM	23.77	22.51
15	39725	36	#0	16QAM	23.05	21.79
15	39725	36	#Mid	16QAM	23.06	21.80
15	39725	36	#Max	16QAM	23.05	21.79
15	39725	75	#0	16QAM	23.08	21.82
15	40620	1	#0	QPSK	24.57	23.31
15	40620	1	#Mid	QPSK	24.61	23.35
15	40620	1	#Max	QPSK	24.65	23.39
15	40620	36	#0	QPSK	23.53	22.27
15	40620	36	#Mid	QPSK	23.56	22.30
15	40620	36	#Max	QPSK	23.69	22.43
15	40620	75	#0	QPSK	23.64	22.38
15	40620	1	#0	16QAM	23.59	22.33
15	40620	1	#Mid	16QAM	23.64	22.38
15	40620	1	#Max	16QAM	23.67	22.41

15	40620	36	#0	16QAM	22.49	21.23
15	40620	36	#Mid	16QAM	22.50	21.24
15	40620	36	#Max	16QAM	22.57	21.31
15	40620	75	#0	16QAM	22.59	21.33
15	41515	1	#0	QPSK	24.92	23.66
15	41515	1	#Mid	QPSK	25.17	23.91
15	41515	1	#Max	QPSK	25.11	23.85
15	41515	36	#0	QPSK	24.03	22.77
15	41515	36	#Mid	QPSK	24.01	22.75
15	41515	36	#Max	QPSK	24.13	22.87
15	41515	75	#0	QPSK	24.09	22.83
15	41515	1	#0	16QAM	23.63	22.37
15	41515	1	#Mid	16QAM	23.84	22.58
15	41515	1	#Max	16QAM	23.87	22.61
15	41515	36	#0	16QAM	22.87	21.61
15	41515	36	#Mid	16QAM	22.84	21.58
15	41515	36	#Max	16QAM	22.94	21.68
15	41515	75	#0	16QAM	22.92	21.66
20	39750	1	#0	QPSK	25.07	23.81
20	39750	1	#Mid	QPSK	25.19	23.93
20	39750	1	#Max	QPSK	24.96	23.70
20	39750	50	#0	QPSK	23.86	22.60
20	39750	50	#Mid	QPSK	23.85	22.59
20	39750	50	#Max	QPSK	23.90	22.64
20	39750	100	#0	QPSK	23.95	22.69
20	39750	1	#0	16QAM	23.96	22.70
20	39750	1	#Mid	16QAM	24.08	22.82
20	39750	1	#Max	16QAM	23.81	22.55
20	39750	50	#0	16QAM	22.93	21.67
20	39750	50	#Mid	16QAM	22.91	21.65
20	39750	50	#Max	16QAM	22.97	21.71
20	39750	100	#0	16QAM	22.93	21.67
20	40620	1	#0	QPSK	24.61	23.35
20	40620	1	#Mid	QPSK	24.70	23.44
20	40620	1	#Max	QPSK	24.74	23.48
20	40620	50	#0	QPSK	23.47	22.21
20	40620	50	#Mid	QPSK	23.45	22.19
20	40620	50	#Max	QPSK	23.56	22.30
20	40620	100	#0	QPSK	23.49	22.23
20	40620	1	#0	16QAM	23.14	21.88
20	40620	1	#Mid	16QAM	23.24	21.98
20	40620	1	#Max	16QAM	23.23	21.97
20	40620	50	#0	16QAM	22.44	21.18

20	40620	50	#Mid	16QAM	22.44	21.18
20	40620	50	#Max	16QAM	22.53	21.27
20	40620	100	#0	16QAM	22.51	21.25
20	41490	1	#0	QPSK	24.92	23.66
20	41490	1	#Mid	QPSK	25.08	23.82
20	41490	1	#Max	QPSK	24.99	23.73
20	41490	50	#0	QPSK	23.81	22.55
20	41490	50	#Mid	QPSK	23.79	22.53
20	41490	50	#Max	QPSK	23.83	22.57
20	41490	100	#0	QPSK	23.81	22.55
20	41490	1	#0	16QAM	23.33	22.07
20	41490	1	#Mid	16QAM	23.50	22.24
20	41490	1	#Max	16QAM	23.47	22.21
20	41490	50	#0	16QAM	22.76	21.50
20	41490	50	#Mid	16QAM	22.76	21.50
20	41490	50	#Max	16QAM	22.79	21.53
20	41490	100	#0	16QAM	22.74	21.48
5	39675	1	#0	64QAM	24.50	23.24
5	39675	1	#Mid	64QAM	24.63	23.37
5	39675	1	#Max	64QAM	24.48	23.22
5	39675	12	#0	64QAM	23.45	22.19
5	39675	12	#Mid	64QAM	23.42	22.16
5	39675	12	#Max	64QAM	23.45	22.19
5	39675	25	#0	64QAM	23.55	22.29
5	40620	1	#0	64QAM	23.97	22.71
5	40620	1	#Mid	64QAM	24.04	22.78
5	40620	1	#Max	64QAM	24.00	22.74
5	40620	12	#0	64QAM	22.92	21.66
5	40620	12	#Mid	64QAM	22.93	21.67
5	40620	12	#Max	64QAM	22.94	21.68
5	40620	25	#0	64QAM	22.92	21.66
5	41565	1	#0	64QAM	24.55	23.29
5	41565	1	#Mid	64QAM	24.74	23.48
5	41565	1	#Max	64QAM	24.67	23.41
5	41565	12	#0	64QAM	23.38	22.12
5	41565	12	#Mid	64QAM	23.39	22.13
5	41565	12	#Max	64QAM	23.39	22.13
5	41565	25	#0	64QAM	23.35	22.09
10	39700	1	#0	64QAM	23.62	22.36
10	39700	1	#Mid	64QAM	23.61	22.35
10	39700	1	#Max	64QAM	23.57	22.31
10	39700	25	#0	64QAM	22.56	21.30
10	39700	25	#Mid	64QAM	22.56	21.30

10	39700	25	#Max	64QAM	22.60	21.34
10	39700	50	#0	64QAM	22.50	21.24
10	40620	1	#0	64QAM	22.96	21.70
10	40620	1	#Mid	64QAM	22.91	21.65
10	40620	1	#Max	64QAM	23.02	21.76
10	40620	25	#0	64QAM	21.94	20.68
10	40620	25	#Mid	64QAM	21.95	20.69
10	40620	25	#Max	64QAM	21.98	20.72
10	40620	50	#0	64QAM	21.97	20.71
10	41540	1	#0	64QAM	23.01	21.75
10	41540	1	#Mid	64QAM	23.11	21.85
10	41540	1	#Max	64QAM	23.18	21.92
10	41540	25	#0	64QAM	22.25	20.99
10	41540	25	#Mid	64QAM	22.24	20.98
10	41540	25	#Max	64QAM	22.25	20.99
10	41540	50	#0	64QAM	22.24	20.98
15	39725	1	#0	64QAM	23.37	22.11
15	39725	1	#Mid	64QAM	23.44	22.18
15	39725	1	#Max	64QAM	23.24	21.98
15	39725	36	#0	64QAM	22.52	21.26
15	39725	36	#Mid	64QAM	22.52	21.26
15	39725	36	#Max	64QAM	22.54	21.28
15	39725	75	#0	64QAM	22.55	21.29
15	40620	1	#0	64QAM	23.08	21.82
15	40620	1	#Mid	64QAM	23.12	21.86
15	40620	1	#Max	64QAM	23.14	21.88
15	40620	36	#0	64QAM	21.97	20.71
15	40620	36	#Mid	64QAM	21.98	20.72
15	40620	36	#Max	64QAM	22.07	20.81
15	40620	75	#0	64QAM	22.04	20.78
15	41515	1	#0	64QAM	23.08	21.82
15	41515	1	#Mid	64QAM	23.29	22.03
15	41515	1	#Max	64QAM	23.34	22.08
15	41515	36	#0	64QAM	22.33	21.07
15	41515	36	#Mid	64QAM	22.33	21.07
15	41515	36	#Max	64QAM	22.42	21.16
15	41515	75	#0	64QAM	22.40	21.14
20	39750	1	#0	64QAM	23.44	22.18
20	39750	1	#Mid	64QAM	23.55	22.29
20	39750	1	#Max	64QAM	23.30	22.04
20	39750	50	#0	64QAM	22.40	21.14
20	39750	50	#Mid	64QAM	22.40	21.14
20	39750	50	#Max	64QAM	22.46	21.20

20	39750	100	#0	64QAM	22.38	21.12
20	40620	1	#0	64QAM	22.63	21.37
20	40620	1	#Mid	64QAM	22.71	21.45
20	40620	1	#Max	64QAM	22.73	21.47
20	40620	50	#0	64QAM	21.91	20.65
20	40620	50	#Mid	64QAM	21.91	20.65
20	40620	50	#Max	64QAM	22.01	20.75
20	40620	100	#0	64QAM	21.99	20.73
20	41490	1	#0	64QAM	22.78	21.52
20	41490	1	#Mid	64QAM	22.95	21.69
20	41490	1	#Max	64QAM	22.93	21.67
20	41490	50	#0	64QAM	22.24	20.98
20	41490	50	#Mid	64QAM	22.22	20.96
20	41490	50	#Max	64QAM	22.22	20.96
20	41490	100	#0	64QAM	22.21	20.95

LTE Band 66						
Bandwidth (MHz)	UL Channel	RB Size	RB Position	Modulation	Power (dBm)	EIRP (dBm)
1.4	131979	1	#0	QPSK	25.03	25.69
1.4	131979	1	#Mid	QPSK	25.18	25.84
1.4	131979	1	#Max	QPSK	25.17	25.83
1.4	131979	3	#0	QPSK	24.98	25.64
1.4	131979	3	#Mid	QPSK	24.96	25.62
1.4	131979	3	#Max	QPSK	24.97	25.63
1.4	131979	6	#0	QPSK	24.14	24.80
1.4	131979	1	#0	16QAM	23.86	24.52
1.4	131979	1	#Mid	16QAM	23.93	24.59
1.4	131979	1	#Max	16QAM	23.88	24.54
1.4	131979	3	#0	16QAM	23.98	24.64
1.4	131979	3	#Mid	16QAM	24.00	24.66
1.4	131979	3	#Max	16QAM	24.02	24.68
1.4	131979	6	#0	16QAM	23.08	23.74
1.4	132322	1	#0	QPSK	24.72	25.38
1.4	132322	1	#Mid	QPSK	24.79	25.45
1.4	132322	1	#Max	QPSK	24.76	25.42
1.4	132322	3	#0	QPSK	24.77	25.43
1.4	132322	3	#Mid	QPSK	24.75	25.41
1.4	132322	3	#Max	QPSK	24.76	25.42
1.4	132322	6	#0	QPSK	23.92	24.58
1.4	132322	1	#0	16QAM	23.84	24.50
1.4	132322	1	#Mid	16QAM	23.86	24.52
1.4	132322	1	#Max	16QAM	23.86	24.52

1.4	132322	3	#0	16QAM	23.71	24.37
1.4	132322	3	#Mid	16QAM	23.71	24.37
1.4	132322	3	#Max	16QAM	23.73	24.39
1.4	132322	6	#0	16QAM	22.84	23.50
1.4	132665	1	#0	QPSK	24.42	25.08
1.4	132665	1	#Mid	QPSK	24.46	25.12
1.4	132665	1	#Max	QPSK	24.43	25.09
1.4	132665	3	#0	QPSK	24.29	24.95
1.4	132665	3	#Mid	QPSK	24.27	24.93
1.4	132665	3	#Max	QPSK	24.25	24.91
1.4	132665	6	#0	QPSK	23.41	24.07
1.4	132665	1	#0	16QAM	23.11	23.77
1.4	132665	1	#Mid	16QAM	23.12	23.78
1.4	132665	1	#Max	16QAM	23.11	23.77
1.4	132665	3	#0	16QAM	23.19	23.85
1.4	132665	3	#Mid	16QAM	23.18	23.84
1.4	132665	3	#Max	16QAM	23.16	23.82
1.4	132665	6	#0	16QAM	22.39	23.05
3	131987	1	#0	QPSK	24.95	25.61
3	131987	1	#Mid	QPSK	25.14	25.80
3	131987	1	#Max	QPSK	25.07	25.73
3	131987	8	#0	QPSK	24.02	24.68
3	131987	8	#Mid	QPSK	24.05	24.71
3	131987	8	#Max	QPSK	24.10	24.76
3	131987	15	#0	QPSK	24.03	24.69
3	131987	1	#0	16QAM	23.64	24.30
3	131987	1	#Mid	16QAM	23.81	24.47
3	131987	1	#Max	16QAM	23.74	24.40
3	131987	8	#0	16QAM	23.00	23.66
3	131987	8	#Mid	16QAM	22.96	23.62
3	131987	8	#Max	16QAM	23.06	23.72
3	131987	15	#0	16QAM	23.00	23.66
3	132322	1	#0	QPSK	24.62	25.28
3	132322	1	#Mid	QPSK	24.72	25.38
3	132322	1	#Max	QPSK	24.62	25.28
3	132322	8	#0	QPSK	23.80	24.46
3	132322	8	#Mid	QPSK	23.80	24.46
3	132322	8	#Max	QPSK	23.85	24.51
3	132322	15	#0	QPSK	23.75	24.41
3	132322	1	#0	16QAM	23.74	24.40
3	132322	1	#Mid	16QAM	23.87	24.53
3	132322	1	#Max	16QAM	23.84	24.50
3	132322	8	#0	16QAM	22.75	23.41

3	132322	8	#Mid	16QAM	22.77	23.43
3	132322	8	#Max	16QAM	22.84	23.50
3	132322	15	#0	16QAM	22.77	23.43
3	132657	1	#0	QPSK	24.20	24.86
3	132657	1	#Mid	QPSK	24.33	24.99
3	132657	1	#Max	QPSK	24.23	24.89
3	132657	8	#0	QPSK	23.36	24.02
3	132657	8	#Mid	QPSK	23.37	24.03
3	132657	8	#Max	QPSK	23.37	24.03
3	132657	15	#0	QPSK	23.32	23.98
3	132657	1	#0	16QAM	23.25	23.91
3	132657	1	#Mid	16QAM	23.33	23.99
3	132657	1	#Max	16QAM	23.22	23.88
3	132657	8	#0	16QAM	22.32	22.98
3	132657	8	#Mid	16QAM	22.31	22.97
3	132657	8	#Max	16QAM	22.34	23.00
3	132657	15	#0	16QAM	22.27	22.93
5	131997	1	#0	QPSK	25.06	25.72
5	131997	1	#Mid	QPSK	25.28	25.94
5	131997	1	#Max	QPSK	25.18	25.84
5	131997	12	#0	QPSK	24.03	24.69
5	131997	12	#Mid	QPSK	24.05	24.71
5	131997	12	#Max	QPSK	24.22	24.88
5	131997	25	#0	QPSK	24.06	24.72
5	131997	1	#0	16QAM	24.18	24.84
5	131997	1	#Mid	16QAM	24.35	25.01
5	131997	1	#Max	16QAM	24.32	24.98
5	131997	12	#0	16QAM	23.01	23.67
5	131997	12	#Mid	16QAM	23.03	23.69
5	131997	12	#Max	16QAM	23.12	23.78
5	131997	25	#0	16QAM	23.05	23.71
5	132322	1	#0	QPSK	24.88	25.54
5	132322	1	#Mid	QPSK	24.99	25.65
5	132322	1	#Max	QPSK	24.89	25.55
5	132322	12	#0	QPSK	23.82	24.48
5	132322	12	#Mid	QPSK	23.82	24.48
5	132322	12	#Max	QPSK	23.90	24.56
5	132322	25	#0	QPSK	23.89	24.55
5	132322	1	#0	16QAM	23.96	24.62
5	132322	1	#Mid	16QAM	24.06	24.72
5	132322	1	#Max	16QAM	24.00	24.66
5	132322	12	#0	16QAM	22.84	23.50
5	132322	12	#Mid	16QAM	22.82	23.48

5	132322	12	#Max	16QAM	22.87	23.53
5	132322	25	#0	16QAM	22.88	23.54
5	132647	1	#0	QPSK	24.30	24.96
5	132647	1	#Mid	QPSK	24.47	25.13
5	132647	1	#Max	QPSK	24.31	24.97
5	132647	12	#0	QPSK	23.41	24.07
5	132647	12	#Mid	QPSK	23.43	24.09
5	132647	12	#Max	QPSK	23.34	24.00
5	132647	25	#0	QPSK	23.36	24.02
5	132647	1	#0	16QAM	23.54	24.20
5	132647	1	#Mid	16QAM	23.63	24.29
5	132647	1	#Max	16QAM	23.50	24.16
5	132647	12	#0	16QAM	22.43	23.09
5	132647	12	#Mid	16QAM	22.46	23.12
5	132647	12	#Max	16QAM	22.38	23.04
5	132647	25	#0	16QAM	22.43	23.09
10	132022	1	#0	QPSK	25.28	25.94
10	132022	1	#Mid	QPSK	25.41	26.07
10	132022	1	#Max	QPSK	25.51	26.17
10	132022	25	#0	QPSK	24.01	24.67
10	132022	25	#Mid	QPSK	23.98	24.64
10	132022	25	#Max	QPSK	24.22	24.88
10	132022	50	#0	QPSK	24.16	24.82
10	132022	1	#0	16QAM	23.93	24.59
10	132022	1	#Mid	16QAM	24.09	24.75
10	132022	1	#Max	16QAM	24.13	24.79
10	132022	25	#0	16QAM	23.02	23.68
10	132022	25	#Mid	16QAM	22.99	23.65
10	132022	25	#Max	16QAM	23.22	23.88
10	132022	50	#0	16QAM	23.13	23.79
10	132322	1	#0	QPSK	24.96	25.62
10	132322	1	#Mid	QPSK	24.95	25.61
10	132322	1	#Max	QPSK	25.02	25.68
10	132322	25	#0	QPSK	23.80	24.46
10	132322	25	#Mid	QPSK	23.82	24.48
10	132322	25	#Max	QPSK	23.90	24.56
10	132322	50	#0	QPSK	23.90	24.56
10	132322	1	#0	16QAM	24.09	24.75
10	132322	1	#Mid	16QAM	24.09	24.75
10	132322	1	#Max	16QAM	24.18	24.84
10	132322	25	#0	16QAM	22.94	23.60
10	132322	25	#Mid	16QAM	22.92	23.58
10	132322	25	#Max	16QAM	23.03	23.69

10	132322	50	#0	16QAM	22.87	23.53
10	132622	1	#0	QPSK	24.61	25.27
10	132622	1	#Mid	QPSK	24.53	25.19
10	132622	1	#Max	QPSK	24.48	25.14
10	132622	25	#0	QPSK	23.45	24.11
10	132622	25	#Mid	QPSK	23.46	24.12
10	132622	25	#Max	QPSK	23.38	24.04
10	132622	50	#0	QPSK	23.42	24.08
10	132622	1	#0	16QAM	23.65	24.31
10	132622	1	#Mid	16QAM	23.57	24.23
10	132622	1	#Max	16QAM	23.51	24.17
10	132622	25	#0	16QAM	22.55	23.21
10	132622	25	#Mid	16QAM	22.52	23.18
10	132622	25	#Max	16QAM	22.40	23.06
10	132622	50	#0	16QAM	22.45	23.11
15	132047	1	#0	QPSK	25.08	25.74
15	132047	1	#Mid	QPSK	25.35	26.01
15	132047	1	#Max	QPSK	25.27	25.93
15	132047	36	#0	QPSK	24.24	24.90
15	132047	36	#Mid	QPSK	24.25	24.91
15	132047	36	#Max	QPSK	24.38	25.04
15	132047	75	#0	QPSK	24.31	24.97
15	132047	1	#0	16QAM	24.11	24.77
15	132047	1	#Mid	16QAM	24.38	25.04
15	132047	1	#Max	16QAM	24.31	24.97
15	132047	36	#0	16QAM	23.11	23.77
15	132047	36	#Mid	16QAM	23.09	23.75
15	132047	36	#Max	16QAM	23.31	23.97
15	132047	75	#0	16QAM	23.21	23.87
15	132322	1	#0	QPSK	25.00	25.66
15	132322	1	#Mid	QPSK	25.12	25.78
15	132322	1	#Max	QPSK	25.13	25.79
15	132322	36	#0	QPSK	23.98	24.64
15	132322	36	#Mid	QPSK	23.94	24.60
15	132322	36	#Max	QPSK	23.98	24.64
15	132322	75	#0	QPSK	23.98	24.64
15	132322	1	#0	16QAM	23.89	24.55
15	132322	1	#Mid	16QAM	23.95	24.61
15	132322	1	#Max	16QAM	23.94	24.60
15	132322	36	#0	16QAM	22.91	23.57
15	132322	36	#Mid	16QAM	22.91	23.57
15	132322	36	#Max	16QAM	22.99	23.65
15	132322	75	#0	16QAM	22.93	23.59

15	132597	1	#0	QPSK	24.69	25.35
15	132597	1	#Mid	QPSK	24.54	25.20
15	132597	1	#Max	QPSK	24.40	25.06
15	132597	36	#0	QPSK	23.66	24.32
15	132597	36	#Mid	QPSK	23.65	24.31
15	132597	36	#Max	QPSK	23.49	24.15
15	132597	75	#0	QPSK	23.52	24.18
15	132597	1	#0	16QAM	23.79	24.45
15	132597	1	#Mid	16QAM	23.67	24.33
15	132597	1	#Max	16QAM	23.48	24.14
15	132597	36	#0	16QAM	22.63	23.29
15	132597	36	#Mid	16QAM	22.64	23.30
15	132597	36	#Max	16QAM	22.47	23.13
15	132597	75	#0	16QAM	22.57	23.23
20	132072	1	#0	QPSK	25.08	25.74
20	132072	1	#Mid	QPSK	25.45	26.11
20	132072	1	#Max	QPSK	25.18	25.84
20	132072	50	#0	QPSK	24.05	24.71
20	132072	50	#Mid	QPSK	24.03	24.69
20	132072	50	#Max	QPSK	24.18	24.84
20	132072	100	#0	QPSK	24.14	24.80
20	132072	1	#0	16QAM	24.08	24.74
20	132072	1	#Mid	16QAM	24.43	25.09
20	132072	1	#Max	16QAM	24.22	24.88
20	132072	50	#0	16QAM	23.05	23.71
20	132072	50	#Mid	16QAM	23.04	23.70
20	132072	50	#Max	16QAM	23.17	23.83
20	132072	100	#0	16QAM	23.07	23.73
20	132322	1	#0	QPSK	24.94	25.60
20	132322	1	#Mid	QPSK	25.09	25.75
20	132322	1	#Max	QPSK	25.01	25.67
20	132322	50	#0	QPSK	23.86	24.52
20	132322	50	#Mid	QPSK	23.87	24.53
20	132322	50	#Max	QPSK	23.96	24.62
20	132322	100	#0	QPSK	23.91	24.57
20	132322	1	#0	16QAM	23.72	24.38
20	132322	1	#Mid	16QAM	23.83	24.49
20	132322	1	#Max	16QAM	23.68	24.34
20	132322	50	#0	16QAM	22.86	23.52
20	132322	50	#Mid	16QAM	22.81	23.47
20	132322	50	#Max	16QAM	22.88	23.54
20	132322	100	#0	16QAM	22.92	23.58
20	132572	1	#0	QPSK	24.82	25.48

20	132572	1	#Mid	QPSK	24.65	25.31
20	132572	1	#Max	QPSK	24.35	25.01
20	132572	50	#0	QPSK	23.67	24.33
20	132572	50	#Mid	QPSK	23.66	24.32
20	132572	50	#Max	QPSK	23.39	24.05
20	132572	100	#0	QPSK	23.47	24.13
20	132572	1	#0	16QAM	23.46	24.12
20	132572	1	#Mid	16QAM	23.33	23.99
20	132572	1	#Max	16QAM	22.97	23.63
20	132572	50	#0	16QAM	22.68	23.34
20	132572	50	#Mid	16QAM	22.69	23.35
20	132572	50	#Max	16QAM	22.42	23.08
20	132572	100	#0	16QAM	22.54	23.20
1.4	131979	1	#0	64QAM	23.40	24.06
1.4	131979	1	#Mid	64QAM	23.55	24.21
1.4	131979	1	#Max	64QAM	23.52	24.18
1.4	131979	3	#0	64QAM	23.61	24.27
1.4	131979	3	#Mid	64QAM	23.61	24.27
1.4	131979	3	#Max	64QAM	23.65	24.31
1.4	131979	6	#0	64QAM	22.71	23.37
1.4	132322	1	#0	64QAM	23.39	24.05
1.4	132322	1	#Mid	64QAM	23.48	24.14
1.4	132322	1	#Max	64QAM	23.46	24.12
1.4	132322	3	#0	64QAM	23.32	23.98
1.4	132322	3	#Mid	64QAM	23.32	23.98
1.4	132322	3	#Max	64QAM	23.34	24.00
1.4	132322	6	#0	64QAM	22.43	23.09
1.4	132665	1	#0	64QAM	22.70	23.36
1.4	132665	1	#Mid	64QAM	22.73	23.39
1.4	132665	1	#Max	64QAM	22.68	23.34
1.4	132665	3	#0	64QAM	22.79	23.45
1.4	132665	3	#Mid	64QAM	22.78	23.44
1.4	132665	3	#Max	64QAM	22.78	23.44
1.4	132665	6	#0	64QAM	21.98	22.64
3	131987	1	#0	64QAM	23.52	24.18
3	131987	1	#Mid	64QAM	23.64	24.30
3	131987	1	#Max	64QAM	23.59	24.25
3	131987	8	#0	64QAM	22.57	23.23
3	131987	8	#Mid	64QAM	22.57	23.23
3	131987	8	#Max	64QAM	22.63	23.29
3	131987	15	#0	64QAM	22.53	23.19
3	132322	1	#0	64QAM	23.04	23.70
3	132322	1	#Mid	64QAM	23.21	23.87

3	132322	1	#Max	64QAM	23.12	23.78
3	132322	8	#0	64QAM	22.40	23.06
3	132322	8	#Mid	64QAM	22.41	23.07
3	132322	8	#Max	64QAM	22.44	23.10
3	132322	15	#0	64QAM	22.40	23.06
3	132657	1	#0	64QAM	22.89	23.55
3	132657	1	#Mid	64QAM	22.98	23.64
3	132657	1	#Max	64QAM	22.89	23.55
3	132657	8	#0	64QAM	21.91	22.57
3	132657	8	#Mid	64QAM	21.93	22.59
3	132657	8	#Max	64QAM	21.95	22.61
3	132657	15	#0	64QAM	21.92	22.58
5	131997	1	#0	64QAM	24.66	25.32
5	131997	1	#Mid	64QAM	24.85	25.51
5	131997	1	#Max	64QAM	24.78	25.44
5	131997	12	#0	64QAM	23.67	24.33
5	131997	12	#Mid	64QAM	23.65	24.31
5	131997	12	#Max	64QAM	23.76	24.42
5	131997	25	#0	64QAM	23.69	24.35
5	132322	1	#0	64QAM	24.44	25.10
5	132322	1	#Mid	64QAM	24.58	25.24
5	132322	1	#Max	64QAM	24.52	25.18
5	132322	12	#0	64QAM	23.44	24.10
5	132322	12	#Mid	64QAM	23.41	24.07
5	132322	12	#Max	64QAM	23.51	24.17
5	132322	25	#0	64QAM	23.47	24.13
5	132647	1	#0	64QAM	23.92	24.58
5	132647	1	#Mid	64QAM	24.04	24.70
5	132647	1	#Max	64QAM	23.89	24.55
5	132647	12	#0	64QAM	23.03	23.69
5	132647	12	#Mid	64QAM	23.00	23.66
5	132647	12	#Max	64QAM	22.94	23.60
5	132647	25	#0	64QAM	22.94	23.60
10	132022	1	#0	64QAM	23.53	24.19
10	132022	1	#Mid	64QAM	23.68	24.34
10	132022	1	#Max	64QAM	23.74	24.40
10	132022	25	#0	64QAM	22.61	23.27
10	132022	25	#Mid	64QAM	22.61	23.27
10	132022	25	#Max	64QAM	22.82	23.48
10	132022	50	#0	64QAM	22.74	23.40
10	132322	1	#0	64QAM	23.69	24.35
10	132322	1	#Mid	64QAM	23.72	24.38
10	132322	1	#Max	64QAM	23.76	24.42

10	132322	25	#0	64QAM	22.48	23.14
10	132322	25	#Mid	64QAM	22.53	23.19
10	132322	25	#Max	64QAM	22.58	23.24
10	132322	50	#0	64QAM	22.49	23.15
10	132622	1	#0	64QAM	23.26	23.92
10	132622	1	#Mid	64QAM	23.17	23.83
10	132622	1	#Max	64QAM	23.11	23.77
10	132622	25	#0	64QAM	22.12	22.78
10	132622	25	#Mid	64QAM	22.15	22.81
10	132622	25	#Max	64QAM	21.96	22.62
10	132622	50	#0	64QAM	22.02	22.68
15	132047	1	#0	64QAM	23.71	24.37
15	132047	1	#Mid	64QAM	23.99	24.65
15	132047	1	#Max	64QAM	23.90	24.56
15	132047	36	#0	64QAM	22.77	23.43
15	132047	36	#Mid	64QAM	22.73	23.39
15	132047	36	#Max	64QAM	22.90	23.56
15	132047	75	#0	64QAM	22.79	23.45
15	132322	1	#0	64QAM	23.50	24.16
15	132322	1	#Mid	64QAM	23.56	24.22
15	132322	1	#Max	64QAM	23.53	24.19
15	132322	36	#0	64QAM	22.49	23.15
15	132322	36	#Mid	64QAM	22.51	23.17
15	132322	36	#Max	64QAM	22.54	23.20
15	132322	75	#0	64QAM	22.53	23.19
15	132597	1	#0	64QAM	23.40	24.06
15	132597	1	#Mid	64QAM	23.31	23.97
15	132597	1	#Max	64QAM	23.09	23.75
15	132597	36	#0	64QAM	22.20	22.86
15	132597	36	#Mid	64QAM	22.23	22.89
15	132597	36	#Max	64QAM	22.08	22.74
15	132597	75	#0	64QAM	22.16	22.82
20	132072	1	#0	64QAM	23.28	23.94
20	132072	1	#Mid	64QAM	23.65	24.31
20	132072	1	#Max	64QAM	23.44	24.10
20	132072	50	#0	64QAM	22.64	23.30
20	132072	50	#Mid	64QAM	22.67	23.33
20	132072	50	#Max	64QAM	22.79	23.45
20	132072	100	#0	64QAM	22.73	23.39
20	132322	1	#0	64QAM	23.59	24.25
20	132322	1	#Mid	64QAM	23.67	24.33
20	132322	1	#Max	64QAM	23.57	24.23
20	132322	50	#0	64QAM	22.48	23.14

20	132322	50	#Mid	64QAM	22.47	23.13
20	132322	50	#Max	64QAM	22.59	23.25
20	132322	100	#0	64QAM	22.52	23.18
20	132572	1	#0	64QAM	23.19	23.85
20	132572	1	#Mid	64QAM	23.05	23.71
20	132572	1	#Max	64QAM	22.71	23.37
20	132572	50	#0	64QAM	22.21	22.87
20	132572	50	#Mid	64QAM	22.22	22.88
20	132572	50	#Max	64QAM	21.97	22.63
20	132572	100	#0	64QAM	22.14	22.80

Upper Antenna

WCDMA Band IV		Conducted Power (dBm)			EIRP (dBm)		
		Channel/ Frequency			Channel/ Frequency		
		1312/1712.4	1413/1732.6	1513/1752.6	1312/1712.4	1413/1732.6	1513/1752.6
RMC	12.2k	23.81	23.76	24.01	23.11	23.06	23.31
HSDPA	Subtest 1	23.23	23.18	23.43	22.53	22.48	22.73
	Subtest 2	23.22	23.17	23.42	22.52	22.47	22.72
	Subtest 3	22.71	22.66	22.91	22.01	21.96	22.21
	Subtest 4	22.70	22.65	22.90	22.00	21.95	22.20
HSUPA	Subtest 1	22.19	22.14	22.39	21.49	21.44	21.69
	Subtest 2	20.18	20.13	20.38	19.48	19.43	19.68
	Subtest 3	21.16	21.12	21.37	20.46	20.42	20.67
	Subtest 4	20.15	20.11	20.36	19.45	19.41	19.66
	Subtest 5	23.64	23.60	23.85	22.94	22.90	23.15
DC-HSDPA	Subtest 1	23.15	23.12	23.35	22.45	22.42	22.65
	Subtest 2	23.14	23.11	23.34	22.44	22.41	22.64
	Subtest 3	22.72	22.60	22.85	22.02	21.90	22.15
	Subtest 4	22.71	22.59	22.84	22.01	21.89	22.14
HSPA+	16QAM	21.30	21.27	21.52	20.60	20.57	20.82

LTE Band 4						
Bandwidth (MHz)	UL Channel	RB Size	RB Position	Modulation	Power (dBm)	EIRP (dBm)
1.4	19957	1	#0	QPSK	24.45	23.85
1.4	19957	1	#Mid	QPSK	24.52	23.92
1.4	19957	1	#Max	QPSK	24.51	23.91
1.4	19957	3	#0	QPSK	24.36	23.76
1.4	19957	3	#Mid	QPSK	24.33	23.73
1.4	19957	3	#Max	QPSK	24.36	23.76
1.4	19957	6	#0	QPSK	23.69	23.09
1.4	19957	1	#0	16QAM	23.46	22.86
1.4	19957	1	#Mid	16QAM	23.54	22.94
1.4	19957	1	#Max	16QAM	23.50	22.90
1.4	19957	3	#0	16QAM	23.26	22.66
1.4	19957	3	#Mid	16QAM	23.26	22.66
1.4	19957	3	#Max	16QAM	23.30	22.70
1.4	19957	6	#0	16QAM	22.49	21.89
1.4	20175	1	#0	QPSK	24.53	23.93
1.4	20175	1	#Mid	QPSK	24.55	23.95
1.4	20175	1	#Max	QPSK	24.53	23.93
1.4	20175	3	#0	QPSK	24.36	23.76
1.4	20175	3	#Mid	QPSK	24.35	23.75
1.4	20175	3	#Max	QPSK	24.31	23.71

1.4	20175	6	#0	QPSK	23.51	22.91
1.4	20175	1	#0	16QAM	23.17	22.57
1.4	20175	1	#Mid	16QAM	23.20	22.60
1.4	20175	1	#Max	16QAM	23.14	22.54
1.4	20175	3	#0	16QAM	23.26	22.66
1.4	20175	3	#Mid	16QAM	23.25	22.65
1.4	20175	3	#Max	16QAM	23.21	22.61
1.4	20175	6	#0	16QAM	22.43	21.83
1.4	20393	1	#0	QPSK	24.52	23.92
1.4	20393	1	#Mid	QPSK	24.58	23.98
1.4	20393	1	#Max	QPSK	24.52	23.92
1.4	20393	3	#0	QPSK	24.25	23.65
1.4	20393	3	#Mid	QPSK	24.25	23.65
1.4	20393	3	#Max	QPSK	24.29	23.69
1.4	20393	6	#0	QPSK	23.50	22.90
1.4	20393	1	#0	16QAM	23.19	22.59
1.4	20393	1	#Mid	16QAM	23.27	22.67
1.4	20393	1	#Max	16QAM	23.23	22.63
1.4	20393	3	#0	16QAM	23.31	22.71
1.4	20393	3	#Mid	16QAM	23.29	22.69
1.4	20393	3	#Max	16QAM	23.35	22.75
1.4	20393	6	#0	16QAM	22.47	21.87
3	19965	1	#0	QPSK	24.31	23.71
3	19965	1	#Mid	QPSK	24.47	23.87
3	19965	1	#Max	QPSK	24.40	23.80
3	19965	8	#0	QPSK	23.47	22.87
3	19965	8	#Mid	QPSK	23.48	22.88
3	19965	8	#Max	QPSK	23.55	22.95
3	19965	15	#0	QPSK	23.41	22.81
3	19965	1	#0	16QAM	23.35	22.75
3	19965	1	#Mid	16QAM	23.49	22.89
3	19965	1	#Max	16QAM	23.40	22.80
3	19965	8	#0	16QAM	22.37	21.77
3	19965	8	#Mid	16QAM	22.38	21.78
3	19965	8	#Max	16QAM	22.45	21.85
3	19965	15	#0	16QAM	22.37	21.77
3	20175	1	#0	QPSK	24.31	23.71
3	20175	1	#Mid	QPSK	24.37	23.77
3	20175	1	#Max	QPSK	24.23	23.63
3	20175	8	#0	QPSK	23.50	22.90
3	20175	8	#Mid	QPSK	23.47	22.87
3	20175	8	#Max	QPSK	23.47	22.87
3	20175	15	#0	QPSK	23.39	22.79

3	20175	1	#0	16QAM	23.32	22.72
3	20175	1	#Mid	16QAM	23.37	22.77
3	20175	1	#Max	16QAM	23.29	22.69
3	20175	8	#0	16QAM	22.36	21.76
3	20175	8	#Mid	16QAM	22.38	21.78
3	20175	8	#Max	16QAM	22.32	21.72
3	20175	15	#0	16QAM	22.28	21.68
3	20385	1	#0	QPSK	24.26	23.66
3	20385	1	#Mid	QPSK	24.46	23.86
3	20385	1	#Max	QPSK	24.38	23.78
3	20385	8	#0	QPSK	23.37	22.77
3	20385	8	#Mid	QPSK	23.35	22.75
3	20385	8	#Max	QPSK	23.43	22.83
3	20385	15	#0	QPSK	23.28	22.68
3	20385	1	#0	16QAM	22.94	22.34
3	20385	1	#Mid	16QAM	23.04	22.44
3	20385	1	#Max	16QAM	22.97	22.37
3	20385	8	#0	16QAM	22.28	21.68
3	20385	8	#Mid	16QAM	22.28	21.68
3	20385	8	#Max	16QAM	22.34	21.74
3	20385	15	#0	16QAM	22.31	21.71
5	19975	1	#0	QPSK	24.55	23.95
5	19975	1	#Mid	QPSK	24.78	24.18
5	19975	1	#Max	QPSK	24.71	24.11
5	19975	12	#0	QPSK	23.49	22.89
5	19975	12	#Mid	QPSK	23.48	22.88
5	19975	12	#Max	QPSK	23.58	22.98
5	19975	25	#0	QPSK	23.47	22.87
5	19975	1	#0	16QAM	23.51	22.91
5	19975	1	#Mid	16QAM	23.67	23.07
5	19975	1	#Max	16QAM	23.61	23.01
5	19975	12	#0	16QAM	22.34	21.74
5	19975	12	#Mid	16QAM	22.35	21.75
5	19975	12	#Max	16QAM	22.44	21.84
5	19975	25	#0	16QAM	22.43	21.83
5	20175	1	#0	QPSK	24.46	23.86
5	20175	1	#Mid	QPSK	24.51	23.91
5	20175	1	#Max	QPSK	24.32	23.72
5	20175	12	#0	QPSK	23.44	22.84
5	20175	12	#Mid	QPSK	23.45	22.85
5	20175	12	#Max	QPSK	23.36	22.76
5	20175	25	#0	QPSK	23.35	22.75
5	20175	1	#0	16QAM	23.57	22.97

5	20175	1	#Mid	16QAM	23.66	23.06
5	20175	1	#Max	16QAM	23.48	22.88
5	20175	12	#0	16QAM	22.39	21.79
5	20175	12	#Mid	16QAM	22.41	21.81
5	20175	12	#Max	16QAM	22.35	21.75
5	20175	25	#0	16QAM	22.39	21.79
5	20375	1	#0	QPSK	24.31	23.71
5	20375	1	#Mid	QPSK	24.50	23.90
5	20375	1	#Max	QPSK	24.43	23.83
5	20375	12	#0	QPSK	23.32	22.72
5	20375	12	#Mid	QPSK	23.29	22.69
5	20375	12	#Max	QPSK	23.36	22.76
5	20375	25	#0	QPSK	23.27	22.67
5	20375	1	#0	16QAM	23.39	22.79
5	20375	1	#Mid	16QAM	23.59	22.99
5	20375	1	#Max	16QAM	23.50	22.90
5	20375	12	#0	16QAM	22.28	21.68
5	20375	12	#Mid	16QAM	22.24	21.64
5	20375	12	#Max	16QAM	22.30	21.70
5	20375	25	#0	16QAM	22.38	21.78
10	20000	1	#0	QPSK	24.76	24.16
10	20000	1	#Mid	QPSK	24.91	24.31
10	20000	1	#Max	QPSK	25.04	24.44
10	20000	25	#0	QPSK	23.45	22.85
10	20000	25	#Mid	QPSK	23.45	22.85
10	20000	25	#Max	QPSK	23.68	23.08
10	20000	50	#0	QPSK	23.49	22.89
10	20000	1	#0	16QAM	23.40	22.80
10	20000	1	#Mid	16QAM	23.48	22.88
10	20000	1	#Max	16QAM	23.58	22.98
10	20000	25	#0	16QAM	22.38	21.78
10	20000	25	#Mid	16QAM	22.41	21.81
10	20000	25	#Max	16QAM	22.64	22.04
10	20000	50	#0	16QAM	22.50	21.90
10	20175	1	#0	QPSK	24.70	24.10
10	20175	1	#Mid	QPSK	24.58	23.98
10	20175	1	#Max	QPSK	24.47	23.87
10	20175	25	#0	QPSK	23.49	22.89
10	20175	25	#Mid	QPSK	23.48	22.88
10	20175	25	#Max	QPSK	23.39	22.79
10	20175	50	#0	QPSK	23.39	22.79
10	20175	1	#0	16QAM	23.67	23.07
10	20175	1	#Mid	16QAM	23.65	23.05

10	20175	1	#Max	16QAM	23.57	22.97
10	20175	25	#0	16QAM	22.50	21.90
10	20175	25	#Mid	16QAM	22.52	21.92
10	20175	25	#Max	16QAM	22.43	21.83
10	20175	50	#0	16QAM	22.42	21.82
10	20350	1	#0	QPSK	24.35	23.75
10	20350	1	#Mid	QPSK	24.43	23.83
10	20350	1	#Max	QPSK	24.54	23.94
10	20350	25	#0	QPSK	23.21	22.61
10	20350	25	#Mid	QPSK	23.22	22.62
10	20350	25	#Max	QPSK	23.33	22.73
10	20350	50	#0	QPSK	23.22	22.62
10	20350	1	#0	16QAM	23.38	22.78
10	20350	1	#Mid	16QAM	23.45	22.85
10	20350	1	#Max	16QAM	23.50	22.90
10	20350	25	#0	16QAM	22.28	21.68
10	20350	25	#Mid	16QAM	22.27	21.67
10	20350	25	#Max	16QAM	22.37	21.77
10	20350	50	#0	16QAM	22.26	21.66
15	20025	1	#0	QPSK	24.57	23.97
15	20025	1	#Mid	QPSK	24.90	24.30
15	20025	1	#Max	QPSK	24.78	24.18
15	20025	36	#0	QPSK	23.75	23.15
15	20025	36	#Mid	QPSK	23.72	23.12
15	20025	36	#Max	QPSK	23.96	23.36
15	20025	75	#0	QPSK	23.79	23.19
15	20025	1	#0	16QAM	23.56	22.96
15	20025	1	#Mid	16QAM	23.85	23.25
15	20025	1	#Max	16QAM	23.72	23.12
15	20025	36	#0	16QAM	22.61	22.01
15	20025	36	#Mid	16QAM	22.59	21.99
15	20025	36	#Max	16QAM	22.79	22.19
15	20025	75	#0	16QAM	22.70	22.10
15	20175	1	#0	QPSK	24.81	24.21
15	20175	1	#Mid	QPSK	24.77	24.17
15	20175	1	#Max	QPSK	24.50	23.90
15	20175	36	#0	QPSK	23.70	23.10
15	20175	36	#Mid	QPSK	23.71	23.11
15	20175	36	#Max	QPSK	23.52	22.92
15	20175	75	#0	QPSK	23.62	23.02
15	20175	1	#0	16QAM	23.49	22.89
15	20175	1	#Mid	16QAM	23.53	22.93
15	20175	1	#Max	16QAM	23.29	22.69

15	20175	36	#0	16QAM	22.60	22.00
15	20175	36	#Mid	16QAM	22.60	22.00
15	20175	36	#Max	16QAM	22.41	21.81
15	20175	75	#0	16QAM	22.53	21.93
15	20325	1	#0	QPSK	24.28	23.68
15	20325	1	#Mid	QPSK	24.46	23.86
15	20325	1	#Max	QPSK	24.48	23.88
15	20325	36	#0	QPSK	23.37	22.77
15	20325	36	#Mid	QPSK	23.37	22.77
15	20325	36	#Max	QPSK	23.53	22.93
15	20325	75	#0	QPSK	23.45	22.85
15	20325	1	#0	16QAM	23.41	22.81
15	20325	1	#Mid	16QAM	23.52	22.92
15	20325	1	#Max	16QAM	23.47	22.87
15	20325	36	#0	16QAM	22.31	21.71
15	20325	36	#Mid	16QAM	22.29	21.69
15	20325	36	#Max	16QAM	22.46	21.86
15	20325	75	#0	16QAM	22.42	21.82
20	20050	1	#0	QPSK	24.62	24.02
20	20050	1	#Mid	QPSK	25.05	24.45
20	20050	1	#Max	QPSK	24.74	24.14
20	20050	50	#0	QPSK	23.50	22.90
20	20050	50	#Mid	QPSK	23.50	22.90
20	20050	50	#Max	QPSK	23.57	22.97
20	20050	100	#0	QPSK	23.50	22.90
20	20050	1	#0	16QAM	23.31	22.71
20	20050	1	#Mid	16QAM	23.68	23.08
20	20050	1	#Max	16QAM	23.34	22.74
20	20050	50	#0	16QAM	22.39	21.79
20	20050	50	#Mid	16QAM	22.39	21.79
20	20050	50	#Max	16QAM	22.52	21.92
20	20050	100	#0	16QAM	22.51	21.91
20	20175	1	#0	QPSK	24.71	24.11
20	20175	1	#Mid	QPSK	24.71	24.11
20	20175	1	#Max	QPSK	24.29	23.69
20	20175	50	#0	QPSK	23.56	22.96
20	20175	50	#Mid	QPSK	23.53	22.93
20	20175	50	#Max	QPSK	23.33	22.73
20	20175	100	#0	QPSK	23.40	22.80
20	20175	1	#0	16QAM	23.25	22.65
20	20175	1	#Mid	16QAM	23.30	22.70
20	20175	1	#Max	16QAM	22.96	22.36
20	20175	50	#0	16QAM	22.54	21.94

20	20175	50	#Mid	16QAM	22.53	21.93
20	20175	50	#Max	16QAM	22.35	21.75
20	20175	100	#0	16QAM	22.43	21.83
20	20300	1	#0	QPSK	24.37	23.77
20	20300	1	#Mid	QPSK	24.50	23.90
20	20300	1	#Max	QPSK	24.46	23.86
20	20300	50	#0	QPSK	23.26	22.66
20	20300	50	#Mid	QPSK	23.23	22.63
20	20300	50	#Max	QPSK	23.32	22.72
20	20300	100	#0	QPSK	23.25	22.65
20	20300	1	#0	16QAM	23.36	22.76
20	20300	1	#Mid	16QAM	23.50	22.90
20	20300	1	#Max	16QAM	23.37	22.77
20	20300	50	#0	16QAM	22.26	21.66
20	20300	50	#Mid	16QAM	22.24	21.64
20	20300	50	#Max	16QAM	22.35	21.75
20	20300	100	#0	16QAM	22.28	21.68
1.4	19957	1	#0	64QAM	22.80	22.20
1.4	19957	1	#Mid	64QAM	22.96	22.36
1.4	19957	1	#Max	64QAM	22.89	22.29
1.4	19957	3	#0	64QAM	22.94	22.34
1.4	19957	3	#Mid	64QAM	22.92	22.32
1.4	19957	3	#Max	64QAM	22.97	22.37
1.4	19957	6	#0	64QAM	22.12	21.52
1.4	20175	1	#0	64QAM	22.95	22.35
1.4	20175	1	#Mid	64QAM	23.01	22.41
1.4	20175	1	#Max	64QAM	22.99	22.39
1.4	20175	3	#0	64QAM	22.83	22.23
1.4	20175	3	#Mid	64QAM	22.81	22.21
1.4	20175	3	#Max	64QAM	22.79	22.19
1.4	20175	6	#0	64QAM	21.99	21.39
1.4	20393	1	#0	64QAM	22.68	22.08
1.4	20393	1	#Mid	64QAM	22.74	22.14
1.4	20393	1	#Max	64QAM	22.72	22.12
1.4	20393	3	#0	64QAM	22.73	22.13
1.4	20393	3	#Mid	64QAM	22.74	22.14
1.4	20393	3	#Max	64QAM	22.75	22.15
1.4	20393	6	#0	64QAM	22.01	21.41
3	19965	1	#0	64QAM	22.88	22.28
3	19965	1	#Mid	64QAM	23.07	22.47
3	19965	1	#Max	64QAM	22.95	22.35
3	19965	8	#0	64QAM	21.97	21.37
3	19965	8	#Mid	64QAM	21.96	21.36

3	19965	8	#Max	64QAM	22.01	21.41
3	19965	15	#0	64QAM	21.89	21.29
3	20175	1	#0	64QAM	22.64	22.04
3	20175	1	#Mid	64QAM	22.75	22.15
3	20175	1	#Max	64QAM	22.65	22.05
3	20175	8	#0	64QAM	21.98	21.38
3	20175	8	#Mid	64QAM	21.96	21.36
3	20175	8	#Max	64QAM	21.94	21.34
3	20175	15	#0	64QAM	21.95	21.35
3	20385	1	#0	64QAM	22.86	22.26
3	20385	1	#Mid	64QAM	22.95	22.35
3	20385	1	#Max	64QAM	22.87	22.27
3	20385	8	#0	64QAM	21.91	21.31
3	20385	8	#Mid	64QAM	21.93	21.33
3	20385	8	#Max	64QAM	21.96	21.36
3	20385	15	#0	64QAM	21.87	21.27
5	19975	1	#0	64QAM	24.05	23.45
5	19975	1	#Mid	64QAM	24.28	23.68
5	19975	1	#Max	64QAM	24.22	23.62
5	19975	12	#0	64QAM	23.02	22.42
5	19975	12	#Mid	64QAM	23.02	22.42
5	19975	12	#Max	64QAM	23.13	22.53
5	19975	25	#0	64QAM	23.00	22.40
5	20175	1	#0	64QAM	24.13	23.53
5	20175	1	#Mid	64QAM	24.20	23.60
5	20175	1	#Max	64QAM	24.01	23.41
5	20175	12	#0	64QAM	23.09	22.49
5	20175	12	#Mid	64QAM	23.05	22.45
5	20175	12	#Max	64QAM	22.97	22.37
5	20175	25	#0	64QAM	22.96	22.36
5	20375	1	#0	64QAM	23.86	23.26
5	20375	1	#Mid	64QAM	24.07	23.47
5	20375	1	#Max	64QAM	23.96	23.36
5	20375	12	#0	64QAM	22.89	22.29
5	20375	12	#Mid	64QAM	22.88	22.28
5	20375	12	#Max	64QAM	22.95	22.35
5	20375	25	#0	64QAM	22.85	22.25
10	20000	1	#0	64QAM	23.16	22.56
10	20000	1	#Mid	64QAM	23.29	22.69
10	20000	1	#Max	64QAM	23.40	22.80
10	20000	25	#0	64QAM	21.98	21.38
10	20000	25	#Mid	64QAM	22.02	21.42
10	20000	25	#Max	64QAM	22.20	21.60

10	20000	50	#0	64QAM	22.04	21.44
10	20175	1	#0	64QAM	22.99	22.39
10	20175	1	#Mid	64QAM	22.94	22.34
10	20175	1	#Max	64QAM	22.86	22.26
10	20175	25	#0	64QAM	22.01	21.41
10	20175	25	#Mid	64QAM	22.02	21.42
10	20175	25	#Max	64QAM	21.91	21.31
10	20175	50	#0	64QAM	21.96	21.36
10	20350	1	#0	64QAM	23.00	22.40
10	20350	1	#Mid	64QAM	23.06	22.46
10	20350	1	#Max	64QAM	23.12	22.52
10	20350	25	#0	64QAM	21.91	21.31
10	20350	25	#Mid	64QAM	21.91	21.31
10	20350	25	#Max	64QAM	22.03	21.43
10	20350	50	#0	64QAM	21.92	21.32
15	20025	1	#0	64QAM	23.04	22.44
15	20025	1	#Mid	64QAM	23.27	22.67
15	20025	1	#Max	64QAM	23.18	22.58
15	20025	36	#0	64QAM	22.17	21.57
15	20025	36	#Mid	64QAM	22.16	21.56
15	20025	36	#Max	64QAM	22.34	21.74
15	20025	75	#0	64QAM	22.24	21.64
15	20175	1	#0	64QAM	23.17	22.57
15	20175	1	#Mid	64QAM	23.23	22.63
15	20175	1	#Max	64QAM	23.06	22.46
15	20175	36	#0	64QAM	22.17	21.57
15	20175	36	#Mid	64QAM	22.17	21.57
15	20175	36	#Max	64QAM	22.00	21.40
15	20175	75	#0	64QAM	22.10	21.50
15	20325	1	#0	64QAM	22.94	22.34
15	20325	1	#Mid	64QAM	23.05	22.45
15	20325	1	#Max	64QAM	23.04	22.44
15	20325	36	#0	64QAM	21.90	21.30
15	20325	36	#Mid	64QAM	21.93	21.33
15	20325	36	#Max	64QAM	22.04	21.44
15	20325	75	#0	64QAM	21.99	21.39
20	20050	1	#0	64QAM	23.09	22.49
20	20050	1	#Mid	64QAM	23.46	22.86
20	20050	1	#Max	64QAM	23.19	22.59
20	20050	50	#0	64QAM	22.00	21.40
20	20050	50	#Mid	64QAM	22.04	21.44
20	20050	50	#Max	64QAM	22.14	21.54
20	20050	100	#0	64QAM	22.05	21.45

20	20175	1	#0	64QAM	22.96	22.36
20	20175	1	#Mid	64QAM	23.01	22.41
20	20175	1	#Max	64QAM	22.70	22.10
20	20175	50	#0	64QAM	22.03	21.43
20	20175	50	#Mid	64QAM	22.03	21.43
20	20175	50	#Max	64QAM	21.86	21.26
20	20175	100	#0	64QAM	21.98	21.38
20	20300	1	#0	64QAM	22.58	21.98
20	20300	1	#Mid	64QAM	22.69	22.09
20	20300	1	#Max	64QAM	22.61	22.01
20	20300	50	#0	64QAM	21.84	21.24
20	20300	50	#Mid	64QAM	21.87	21.27
20	20300	50	#Max	64QAM	21.95	21.35
20	20300	100	#0	64QAM	21.89	21.29

LTE Band 7						
Bandwidth (MHz)	UL Channel	RB Size	RB Position	Modulation	Power (dBm)	EIRP (dBm)
5	20775	1	#0	QPSK	24.59	23.39
5	20775	1	#Mid	QPSK	24.75	23.55
5	20775	1	#Max	QPSK	24.66	23.46
5	20775	12	#0	QPSK	23.52	22.32
5	20775	12	#Mid	QPSK	23.49	22.29
5	20775	12	#Max	QPSK	23.54	22.34
5	20775	25	#0	QPSK	23.52	22.32
5	20775	1	#0	16QAM	23.60	22.40
5	20775	1	#Mid	16QAM	23.73	22.53
5	20775	1	#Max	16QAM	23.62	22.42
5	20775	12	#0	16QAM	22.40	21.20
5	20775	12	#Mid	16QAM	22.41	21.21
5	20775	12	#Max	16QAM	22.46	21.26
5	20775	25	#0	16QAM	22.45	21.25
5	21100	1	#0	QPSK	24.19	22.99
5	21100	1	#Mid	QPSK	24.33	23.13
5	21100	1	#Max	QPSK	24.25	23.05
5	21100	12	#0	QPSK	23.26	22.06
5	21100	12	#Mid	QPSK	23.23	22.03
5	21100	12	#Max	QPSK	23.20	22.00
5	21100	25	#0	QPSK	23.17	21.97
5	21100	1	#0	16QAM	23.28	22.08
5	21100	1	#Mid	16QAM	23.42	22.22
5	21100	1	#Max	16QAM	23.25	22.05
5	21100	12	#0	16QAM	22.11	20.91

5	21100	12	#Mid	16QAM	22.12	20.92
5	21100	12	#Max	16QAM	22.09	20.89
5	21100	25	#0	16QAM	22.15	20.95
5	21425	1	#0	QPSK	23.46	22.26
5	21425	1	#Mid	QPSK	23.38	22.18
5	21425	1	#Max	QPSK	22.96	21.76
5	21425	12	#0	QPSK	23.35	22.15
5	21425	12	#Mid	QPSK	23.38	22.18
5	21425	12	#Max	QPSK	23.13	21.93
5	21425	25	#0	QPSK	23.25	22.05
5	21425	1	#0	16QAM	23.22	22.02
5	21425	1	#Mid	16QAM	23.12	21.92
5	21425	1	#Max	16QAM	22.72	21.52
5	21425	12	#0	16QAM	22.11	20.91
5	21425	12	#Mid	16QAM	22.11	20.91
5	21425	12	#Max	16QAM	22.09	20.89
5	21425	25	#0	16QAM	22.14	20.94
10	20800	1	#0	QPSK	24.64	23.44
10	20800	1	#Mid	QPSK	24.65	23.45
10	20800	1	#Max	QPSK	24.39	23.19
10	20800	25	#0	QPSK	23.54	22.34
10	20800	25	#Mid	QPSK	23.53	22.33
10	20800	25	#Max	QPSK	23.60	22.40
10	20800	50	#0	QPSK	23.55	22.35
10	20800	1	#0	16QAM	23.62	22.42
10	20800	1	#Mid	16QAM	23.67	22.47
10	20800	1	#Max	16QAM	23.72	22.52
10	20800	25	#0	16QAM	22.42	21.22
10	20800	25	#Mid	16QAM	22.41	21.21
10	20800	25	#Max	16QAM	22.51	21.31
10	20800	50	#0	16QAM	22.43	21.23
10	21100	1	#0	QPSK	23.94	22.74
10	21100	1	#Mid	QPSK	24.21	23.01
10	21100	1	#Max	QPSK	24.31	23.11
10	21100	25	#0	QPSK	23.26	22.06
10	21100	25	#Mid	QPSK	23.24	22.04
10	21100	25	#Max	QPSK	23.19	21.99
10	21100	50	#0	QPSK	23.19	21.99
10	21100	1	#0	16QAM	23.16	21.96
10	21100	1	#Mid	16QAM	23.09	21.89
10	21100	1	#Max	16QAM	23.02	21.82
10	21100	25	#0	16QAM	22.18	20.98
10	21100	25	#Mid	16QAM	22.18	20.98

10	21100	25	#Max	16QAM	22.13	20.93
10	21100	50	#0	16QAM	22.16	20.96
10	21400	1	#0	QPSK	23.36	22.16
10	21400	1	#Mid	QPSK	23.30	22.10
10	21400	1	#Max	QPSK	22.80	21.60
10	21400	25	#0	QPSK	23.27	22.07
10	21400	25	#Mid	QPSK	23.30	22.10
10	21400	25	#Max	QPSK	23.19	21.99
10	21400	50	#0	QPSK	23.25	22.05
10	21400	1	#0	16QAM	23.21	22.01
10	21400	1	#Mid	16QAM	23.16	21.96
10	21400	1	#Max	16QAM	22.63	21.43
10	21400	25	#0	16QAM	22.23	21.03
10	21400	25	#Mid	16QAM	22.22	21.02
10	21400	25	#Max	16QAM	22.22	21.02
10	21400	50	#0	16QAM	22.13	20.93
15	20825	1	#0	QPSK	24.60	23.40
15	20825	1	#Mid	QPSK	24.59	23.39
15	20825	1	#Max	QPSK	24.15	22.95
15	20825	36	#0	QPSK	23.71	22.51
15	20825	36	#Mid	QPSK	23.70	22.50
15	20825	36	#Max	QPSK	23.82	22.62
15	20825	75	#0	QPSK	23.71	22.51
15	20825	1	#0	16QAM	23.51	22.31
15	20825	1	#Mid	16QAM	23.66	22.46
15	20825	1	#Max	16QAM	23.66	22.46
15	20825	36	#0	16QAM	22.54	21.34
15	20825	36	#Mid	16QAM	22.54	21.34
15	20825	36	#Max	16QAM	22.65	21.45
15	20825	75	#0	16QAM	22.57	21.37
15	21100	1	#0	QPSK	23.57	22.37
15	21100	1	#Mid	QPSK	23.97	22.77
15	21100	1	#Max	QPSK	24.10	22.90
15	21100	36	#0	QPSK	23.42	22.22
15	21100	36	#Mid	QPSK	23.45	22.25
15	21100	36	#Max	QPSK	23.34	22.14
15	21100	75	#0	QPSK	23.41	22.21
15	21100	1	#0	16QAM	23.31	22.11
15	21100	1	#Mid	16QAM	23.28	22.08
15	21100	1	#Max	16QAM	23.15	21.95
15	21100	36	#0	16QAM	22.23	21.03
15	21100	36	#Mid	16QAM	22.25	21.05
15	21100	36	#Max	16QAM	22.17	20.97

15	21100	75	#0	16QAM	22.27	21.07
15	21375	1	#0	QPSK	23.66	22.46
15	21375	1	#Mid	QPSK	23.39	22.19
15	21375	1	#Max	QPSK	22.90	21.70
15	21375	36	#0	QPSK	23.40	22.20
15	21375	36	#Mid	QPSK	23.39	22.19
15	21375	36	#Max	QPSK	23.17	21.97
15	21375	75	#0	QPSK	23.23	22.03
15	21375	1	#0	16QAM	22.92	21.72
15	21375	1	#Mid	16QAM	23.05	21.85
15	21375	1	#Max	16QAM	22.48	21.28
15	21375	36	#0	16QAM	22.23	21.03
15	21375	36	#Mid	16QAM	22.25	21.05
15	21375	36	#Max	16QAM	22.38	21.18
15	21375	75	#0	16QAM	22.31	21.11
20	20850	1	#0	QPSK	24.57	23.37
20	20850	1	#Mid	QPSK	24.53	23.33
20	20850	1	#Max	QPSK	23.91	22.71
20	20850	50	#0	QPSK	23.42	22.22
20	20850	50	#Mid	QPSK	23.41	22.21
20	20850	50	#Max	QPSK	23.54	22.34
20	20850	100	#0	QPSK	23.44	22.24
20	20850	1	#0	16QAM	23.22	22.02
20	20850	1	#Mid	16QAM	23.49	22.29
20	20850	1	#Max	16QAM	23.39	22.19
20	20850	50	#0	16QAM	22.29	21.09
20	20850	50	#Mid	16QAM	22.30	21.10
20	20850	50	#Max	16QAM	22.43	21.23
20	20850	100	#0	16QAM	22.38	21.18
20	21100	1	#0	QPSK	23.41	22.21
20	21100	1	#Mid	QPSK	24.00	22.80
20	21100	1	#Max	QPSK	24.05	22.85
20	21100	50	#0	QPSK	23.19	21.99
20	21100	50	#Mid	QPSK	23.20	22.00
20	21100	50	#Max	QPSK	23.12	21.92
20	21100	100	#0	QPSK	23.16	21.96
20	21100	1	#0	16QAM	22.92	21.72
20	21100	1	#Mid	16QAM	22.99	21.79
20	21100	1	#Max	16QAM	22.69	21.49
20	21100	50	#0	16QAM	22.13	20.93
20	21100	50	#Mid	16QAM	22.14	20.94
20	21100	50	#Max	16QAM	22.12	20.92
20	21100	100	#0	16QAM	22.12	20.92

20	21350	1	#0	QPSK	23.79	22.59
20	21350	1	#Mid	QPSK	23.46	22.26
20	21350	1	#Max	QPSK	22.86	21.66
20	21350	50	#0	QPSK	23.13	21.93
20	21350	50	#Mid	QPSK	23.08	21.88
20	21350	50	#Max	QPSK	23.21	22.01
20	21350	100	#0	QPSK	23.16	21.96
20	21350	1	#0	16QAM	22.94	21.74
20	21350	1	#Mid	16QAM	23.34	22.14
20	21350	1	#Max	16QAM	22.67	21.47
20	21350	50	#0	16QAM	22.05	20.85
20	21350	50	#Mid	16QAM	22.05	20.85
20	21350	50	#Max	16QAM	22.11	20.91
20	21350	100	#0	16QAM	22.06	20.86
5	20775	1	#0	64QAM	24.06	22.86
5	20775	1	#Mid	64QAM	24.22	23.02
5	20775	1	#Max	64QAM	24.08	22.88
5	20775	12	#0	64QAM	22.99	21.79
5	20775	12	#Mid	64QAM	22.99	21.79
5	20775	12	#Max	64QAM	23.00	21.80
5	20775	25	#0	64QAM	22.95	21.75
5	21100	1	#0	64QAM	23.50	22.30
5	21100	1	#Mid	64QAM	23.67	22.47
5	21100	1	#Max	64QAM	23.65	22.45
5	21100	12	#0	64QAM	22.70	21.50
5	21100	12	#Mid	64QAM	22.71	21.51
5	21100	12	#Max	64QAM	22.67	21.47
5	21100	25	#0	64QAM	22.62	21.42
5	21425	1	#0	64QAM	22.82	21.62
5	21425	1	#Mid	64QAM	22.76	21.56
5	21425	1	#Max	64QAM	22.35	21.15
5	21425	12	#0	64QAM	22.80	21.60
5	21425	12	#Mid	64QAM	22.77	21.57
5	21425	12	#Max	64QAM	22.51	21.31
5	21425	25	#0	64QAM	22.64	21.44
10	20800	1	#0	64QAM	23.10	21.90
10	20800	1	#Mid	64QAM	23.14	21.94
10	20800	1	#Max	64QAM	23.21	22.01
10	20800	25	#0	64QAM	21.93	20.73
10	20800	25	#Mid	64QAM	21.94	20.74
10	20800	25	#Max	64QAM	22.02	20.82
10	20800	50	#0	64QAM	21.92	20.72
10	21100	1	#0	64QAM	22.90	21.70

10	21100	1	#Mid	64QAM	22.81	21.61
10	21100	1	#Max	64QAM	22.72	21.52
10	21100	25	#0	64QAM	21.67	20.47
10	21100	25	#Mid	64QAM	21.66	20.46
10	21100	25	#Max	64QAM	21.62	20.42
10	21100	50	#0	64QAM	21.61	20.41
10	21400	1	#0	64QAM	22.58	21.38
10	21400	1	#Mid	64QAM	22.51	21.31
10	21400	1	#Max	64QAM	22.00	20.80
10	21400	25	#0	64QAM	21.62	20.42
10	21400	25	#Mid	64QAM	21.62	20.42
10	21400	25	#Max	64QAM	21.65	20.45
10	21400	50	#0	64QAM	21.62	20.42
15	20825	1	#0	64QAM	22.98	21.78
15	20825	1	#Mid	64QAM	23.13	21.93
15	20825	1	#Max	64QAM	23.11	21.91
15	20825	36	#0	64QAM	21.99	20.79
15	20825	36	#Mid	64QAM	21.99	20.79
15	20825	36	#Max	64QAM	22.12	20.92
15	20825	75	#0	64QAM	22.05	20.85
15	21100	1	#0	64QAM	22.76	21.56
15	21100	1	#Mid	64QAM	22.81	21.61
15	21100	1	#Max	64QAM	22.61	21.41
15	21100	36	#0	64QAM	21.73	20.53
15	21100	36	#Mid	64QAM	21.73	20.53
15	21100	36	#Max	64QAM	21.66	20.46
15	21100	75	#0	64QAM	21.73	20.53
15	21375	1	#0	64QAM	22.40	21.20
15	21375	1	#Mid	64QAM	22.55	21.35
15	21375	1	#Max	64QAM	22.03	20.83
15	21375	36	#0	64QAM	21.69	20.49
15	21375	36	#Mid	64QAM	21.71	20.51
15	21375	36	#Max	64QAM	21.83	20.63
15	21375	75	#0	64QAM	21.80	20.60
20	20850	1	#0	64QAM	22.72	21.52
20	20850	1	#Mid	64QAM	22.97	21.77
20	20850	1	#Max	64QAM	22.85	21.65
20	20850	50	#0	64QAM	21.78	20.58
20	20850	50	#Mid	64QAM	21.79	20.59
20	20850	50	#Max	64QAM	21.91	20.71
20	20850	100	#0	64QAM	21.88	20.68
20	21100	1	#0	64QAM	22.41	21.21
20	21100	1	#Mid	64QAM	22.46	21.26

20	21100	1	#Max	64QAM	22.18	20.98
20	21100	50	#0	64QAM	21.63	20.43
20	21100	50	#Mid	64QAM	21.64	20.44
20	21100	50	#Max	64QAM	21.58	20.38
20	21100	100	#0	64QAM	21.60	20.40
20	21350	1	#0	64QAM	22.43	21.23
20	21350	1	#Mid	64QAM	22.84	21.64
20	21350	1	#Max	64QAM	22.19	20.99
20	21350	50	#0	64QAM	21.52	20.32
20	21350	50	#Mid	64QAM	21.53	20.33
20	21350	50	#Max	64QAM	21.62	20.42
20	21350	100	#0	64QAM	21.56	20.36

LTE Band 12						
Bandwidth (MHz)	UL Channel	RB Size	RB Position	Modulation	Power (dBm)	ERP (dBm)
1.4	23017	1	#0	QPSK	24.20	14.09
1.4	23017	1	#Mid	QPSK	24.24	14.13
1.4	23017	1	#Max	QPSK	24.16	14.05
1.4	23017	3	#0	QPSK	24.09	13.98
1.4	23017	3	#Mid	QPSK	24.12	14.01
1.4	23017	3	#Max	QPSK	24.12	14.01
1.4	23017	6	#0	QPSK	23.20	13.09
1.4	23017	1	#0	16QAM	23.01	12.90
1.4	23017	1	#Mid	16QAM	23.15	13.04
1.4	23017	1	#Max	16QAM	23.08	12.97
1.4	23017	3	#0	16QAM	23.22	13.11
1.4	23017	3	#Mid	16QAM	23.18	13.07
1.4	23017	3	#Max	16QAM	23.24	13.13
1.4	23017	6	#0	16QAM	22.20	12.09
1.4	23095	1	#0	QPSK	24.01	13.90
1.4	23095	1	#Mid	QPSK	24.07	13.96
1.4	23095	1	#Max	QPSK	24.01	13.90
1.4	23095	3	#0	QPSK	24.06	13.95
1.4	23095	3	#Mid	QPSK	24.08	13.97
1.4	23095	3	#Max	QPSK	24.05	13.94
1.4	23095	6	#0	QPSK	23.18	13.07
1.4	23095	1	#0	16QAM	23.13	13.02
1.4	23095	1	#Mid	16QAM	23.20	13.09
1.4	23095	1	#Max	16QAM	23.15	13.04
1.4	23095	3	#0	16QAM	23.05	12.94
1.4	23095	3	#Mid	16QAM	23.02	12.91
1.4	23095	3	#Max	16QAM	23.06	12.95

1.4	23095	6	#0	16QAM	22.14	12.03
1.4	23173	1	#0	QPSK	24.13	14.02
1.4	23173	1	#Mid	QPSK	24.18	14.07
1.4	23173	1	#Max	QPSK	24.21	14.10
1.4	23173	3	#0	QPSK	24.07	13.96
1.4	23173	3	#Mid	QPSK	24.02	13.91
1.4	23173	3	#Max	QPSK	24.00	13.89
1.4	23173	6	#0	QPSK	23.18	13.07
1.4	23173	1	#0	16QAM	22.84	12.73
1.4	23173	1	#Mid	16QAM	22.83	12.72
1.4	23173	1	#Max	16QAM	22.83	12.72
1.4	23173	3	#0	16QAM	22.92	12.81
1.4	23173	3	#Mid	16QAM	22.91	12.80
1.4	23173	3	#Max	16QAM	22.88	12.77
1.4	23173	6	#0	16QAM	22.07	11.96
3	23025	1	#0	QPSK	23.90	13.79
3	23025	1	#Mid	QPSK	24.00	13.89
3	23025	1	#Max	QPSK	23.90	13.79
3	23025	8	#0	QPSK	23.12	13.01
3	23025	8	#Mid	QPSK	23.12	13.01
3	23025	8	#Max	QPSK	23.22	13.11
3	23025	15	#0	QPSK	23.17	13.06
3	23025	1	#0	16QAM	23.04	12.93
3	23025	1	#Mid	16QAM	23.23	13.12
3	23025	1	#Max	16QAM	23.11	13.00
3	23025	8	#0	16QAM	22.11	12.00
3	23025	8	#Mid	16QAM	22.07	11.96
3	23025	8	#Max	16QAM	22.21	12.10
3	23025	15	#0	16QAM	22.11	12.00
3	23095	1	#0	QPSK	23.92	13.81
3	23095	1	#Mid	QPSK	23.99	13.88
3	23095	1	#Max	QPSK	23.88	13.77
3	23095	8	#0	QPSK	23.16	13.05
3	23095	8	#Mid	QPSK	23.13	13.02
3	23095	8	#Max	QPSK	23.14	13.03
3	23095	15	#0	QPSK	23.11	13.00
3	23095	1	#0	16QAM	23.02	12.91
3	23095	1	#Mid	16QAM	23.14	13.03
3	23095	1	#Max	16QAM	23.04	12.93
3	23095	8	#0	16QAM	22.09	11.98
3	23095	8	#Mid	16QAM	22.11	12.00
3	23095	8	#Max	16QAM	22.08	11.97
3	23095	15	#0	16QAM	21.97	11.86

3	23165	1	#0	QPSK	23.75	13.64
3	23165	1	#Mid	QPSK	24.03	13.92
3	23165	1	#Max	QPSK	24.02	13.91
3	23165	8	#0	QPSK	23.02	12.91
3	23165	8	#Mid	QPSK	22.99	12.88
3	23165	8	#Max	QPSK	23.14	13.03
3	23165	15	#0	QPSK	23.05	12.94
3	23165	1	#0	16QAM	22.63	12.52
3	23165	1	#Mid	16QAM	22.80	12.69
3	23165	1	#Max	16QAM	22.77	12.66
3	23165	8	#0	16QAM	21.97	11.86
3	23165	8	#Mid	16QAM	21.97	11.86
3	23165	8	#Max	16QAM	22.05	11.94
3	23165	15	#0	16QAM	22.03	11.92
5	23035	1	#0	QPSK	24.17	14.06
5	23035	1	#Mid	QPSK	24.34	14.23
5	23035	1	#Max	QPSK	24.17	14.06
5	23035	12	#0	QPSK	23.17	13.06
5	23035	12	#Mid	QPSK	23.09	12.98
5	23035	12	#Max	QPSK	23.31	13.20
5	23035	25	#0	QPSK	23.24	13.13
5	23035	1	#0	16QAM	23.37	13.26
5	23035	1	#Mid	16QAM	23.56	13.45
5	23035	1	#Max	16QAM	23.37	13.26
5	23035	12	#0	16QAM	22.10	11.99
5	23035	12	#Mid	16QAM	22.14	12.03
5	23035	12	#Max	16QAM	22.35	12.24
5	23035	25	#0	16QAM	22.26	12.15
5	23095	1	#0	QPSK	24.20	14.09
5	23095	1	#Mid	QPSK	24.30	14.19
5	23095	1	#Max	QPSK	24.18	14.07
5	23095	12	#0	QPSK	23.25	13.14
5	23095	12	#Mid	QPSK	23.23	13.12
5	23095	12	#Max	QPSK	23.10	12.99
5	23095	25	#0	QPSK	23.13	13.02
5	23095	1	#0	16QAM	23.39	13.28
5	23095	1	#Mid	16QAM	23.47	13.36
5	23095	1	#Max	16QAM	23.40	13.29
5	23095	12	#0	16QAM	22.15	12.04
5	23095	12	#Mid	16QAM	22.14	12.03
5	23095	12	#Max	16QAM	22.01	11.90
5	23095	25	#0	16QAM	22.15	12.04
5	23155	1	#0	QPSK	24.17	14.06

5	23155	1	#Mid	QPSK	24.28	14.17
5	23155	1	#Max	QPSK	24.27	14.16
5	23155	12	#0	QPSK	23.09	12.98
5	23155	12	#Mid	QPSK	23.06	12.95
5	23155	12	#Max	QPSK	23.12	13.01
5	23155	25	#0	QPSK	23.07	12.96
5	23155	1	#0	16QAM	23.29	13.18
5	23155	1	#Mid	16QAM	23.37	13.26
5	23155	1	#Max	16QAM	23.21	13.10
5	23155	12	#0	16QAM	21.97	11.86
5	23155	12	#Mid	16QAM	21.93	11.82
5	23155	12	#Max	16QAM	22.04	11.93
5	23155	25	#0	16QAM	22.03	11.92
10	23060	1	#0	QPSK	24.27	14.16
10	23060	1	#Mid	QPSK	24.31	14.20
10	23060	1	#Max	QPSK	24.25	14.14
10	23060	25	#0	QPSK	23.00	12.89
10	23060	25	#Mid	QPSK	23.02	12.91
10	23060	25	#Max	QPSK	23.13	13.02
10	23060	50	#0	QPSK	23.07	12.96
10	23060	1	#0	16QAM	23.48	13.37
10	23060	1	#Mid	16QAM	23.51	13.40
10	23060	1	#Max	16QAM	23.47	13.36
10	23060	25	#0	16QAM	22.09	11.98
10	23060	25	#Mid	16QAM	22.10	11.99
10	23060	25	#Max	16QAM	22.16	12.05
10	23060	50	#0	16QAM	22.01	11.90
10	23095	1	#0	QPSK	24.28	14.17
10	23095	1	#Mid	QPSK	24.31	14.20
10	23095	1	#Max	QPSK	24.24	14.13
10	23095	25	#0	QPSK	23.18	13.07
10	23095	25	#Mid	QPSK	23.21	13.10
10	23095	25	#Max	QPSK	23.14	13.03
10	23095	50	#0	QPSK	23.17	13.06
10	23095	1	#0	16QAM	23.43	13.32
10	23095	1	#Mid	16QAM	23.43	13.32
10	23095	1	#Max	16QAM	23.37	13.26
10	23095	25	#0	16QAM	22.18	12.07
10	23095	25	#Mid	16QAM	22.19	12.08
10	23095	25	#Max	16QAM	22.13	12.02
10	23095	50	#0	16QAM	22.11	12.00
10	23130	1	#0	QPSK	24.36	14.25
10	23130	1	#Mid	QPSK	24.38	14.27

10	23130	1	#Max	QPSK	24.43	14.32
10	23130	25	#0	QPSK	23.27	13.16
10	23130	25	#Mid	QPSK	23.24	13.13
10	23130	25	#Max	QPSK	23.27	13.16
10	23130	50	#0	QPSK	23.26	13.15
10	23130	1	#0	16QAM	23.15	13.04
10	23130	1	#Mid	16QAM	23.17	13.06
10	23130	1	#Max	16QAM	23.04	12.93
10	23130	25	#0	16QAM	22.28	12.17
10	23130	25	#Mid	16QAM	22.28	12.17
10	23130	25	#Max	16QAM	22.25	12.14
10	23130	50	#0	16QAM	22.22	12.11
1.4	23017	1	#0	64QAM	22.60	12.49
1.4	23017	1	#Mid	64QAM	22.66	12.55
1.4	23017	1	#Max	64QAM	22.59	12.48
1.4	23017	3	#0	64QAM	22.69	12.58
1.4	23017	3	#Mid	64QAM	22.70	12.59
1.4	23017	3	#Max	64QAM	22.77	12.66
1.4	23017	6	#0	64QAM	21.72	11.61
1.4	23095	1	#0	64QAM	22.64	12.53
1.4	23095	1	#Mid	64QAM	22.73	12.62
1.4	23095	1	#Max	64QAM	22.69	12.58
1.4	23095	3	#0	64QAM	22.56	12.45
1.4	23095	3	#Mid	64QAM	22.56	12.45
1.4	23095	3	#Max	64QAM	22.55	12.44
1.4	23095	6	#0	64QAM	21.63	11.52
1.4	23173	1	#0	64QAM	22.33	12.22
1.4	23173	1	#Mid	64QAM	22.35	12.24
1.4	23173	1	#Max	64QAM	22.35	12.24
1.4	23173	3	#0	64QAM	22.43	12.32
1.4	23173	3	#Mid	64QAM	22.44	12.33
1.4	23173	3	#Max	64QAM	22.41	12.30
1.4	23173	6	#0	64QAM	21.58	11.47
3	23025	1	#0	64QAM	22.57	12.46
3	23025	1	#Mid	64QAM	22.75	12.64
3	23025	1	#Max	64QAM	22.60	12.49
3	23025	8	#0	64QAM	21.60	11.49
3	23025	8	#Mid	64QAM	21.57	11.46
3	23025	8	#Max	64QAM	21.71	11.60
3	23025	15	#0	64QAM	21.64	11.53
3	23095	1	#0	64QAM	22.58	12.47
3	23095	1	#Mid	64QAM	22.64	12.53
3	23095	1	#Max	64QAM	22.56	12.45

3	23095	8	#0	64QAM	21.62	11.51
3	23095	8	#Mid	64QAM	21.62	11.51
3	23095	8	#Max	64QAM	21.61	11.50
3	23095	15	#0	64QAM	21.47	11.36
3	23165	1	#0	64QAM	22.19	12.08
3	23165	1	#Mid	64QAM	22.35	12.24
3	23165	1	#Max	64QAM	22.25	12.14
3	23165	8	#0	64QAM	21.51	11.40
3	23165	8	#Mid	64QAM	21.53	11.42
3	23165	8	#Max	64QAM	21.58	11.47
3	23165	15	#0	64QAM	21.54	11.43
5	23035	1	#0	64QAM	23.75	13.64
5	23035	1	#Mid	64QAM	23.88	13.77
5	23035	1	#Max	64QAM	23.76	13.65
5	23035	12	#0	64QAM	22.66	12.55
5	23035	12	#Mid	64QAM	22.67	12.56
5	23035	12	#Max	64QAM	22.84	12.73
5	23035	25	#0	64QAM	22.75	12.64
5	23095	1	#0	64QAM	23.73	13.62
5	23095	1	#Mid	64QAM	23.84	13.73
5	23095	1	#Max	64QAM	23.70	13.59
5	23095	12	#0	64QAM	22.77	12.66
5	23095	12	#Mid	64QAM	22.77	12.66
5	23095	12	#Max	64QAM	22.62	12.51
5	23095	25	#0	64QAM	22.67	12.56
5	23155	1	#0	64QAM	23.61	13.50
5	23155	1	#Mid	64QAM	23.71	13.60
5	23155	1	#Max	64QAM	23.69	13.58
5	23155	12	#0	64QAM	22.54	12.43
5	23155	12	#Mid	64QAM	22.53	12.42
5	23155	12	#Max	64QAM	22.63	12.52
5	23155	25	#0	64QAM	22.57	12.46
10	23060	1	#0	64QAM	22.92	12.81
10	23060	1	#Mid	64QAM	23.00	12.89
10	23060	1	#Max	64QAM	22.92	12.81
10	23060	25	#0	64QAM	21.59	11.48
10	23060	25	#Mid	64QAM	21.60	11.49
10	23060	25	#Max	64QAM	21.62	11.51
10	23060	50	#0	64QAM	21.56	11.45
10	23095	1	#0	64QAM	22.69	12.58
10	23095	1	#Mid	64QAM	22.69	12.58
10	23095	1	#Max	64QAM	22.64	12.53
10	23095	25	#0	64QAM	21.66	11.55

10	23095	25	#Mid	64QAM	21.71	11.60
10	23095	25	#Max	64QAM	21.67	11.56
10	23095	50	#0	64QAM	21.67	11.56
10	23130	1	#0	64QAM	22.99	12.88
10	23130	1	#Mid	64QAM	23.00	12.89
10	23130	1	#Max	64QAM	22.85	12.74
10	23130	25	#0	64QAM	21.85	11.74
10	23130	25	#Mid	64QAM	21.87	11.76
10	23130	25	#Max	64QAM	21.82	11.71
10	23130	50	#0	64QAM	21.77	11.66

LTE Band 13						
Bandwidth (MHz)	UL Channel	RB Size	RB Position	Modulation	Power (dBm)	ERP (dBm)
5	23205	1	#0	QPSK	24.58	14.47
5	23205	1	#Mid	QPSK	24.68	14.57
5	23205	1	#Max	QPSK	24.56	14.45
5	23205	12	#0	QPSK	23.47	13.36
5	23205	12	#Mid	QPSK	23.46	13.35
5	23205	12	#Max	QPSK	23.49	13.38
5	23205	25	#0	QPSK	23.44	13.33
5	23205	1	#0	16QAM	23.59	13.48
5	23205	1	#Mid	16QAM	23.72	13.61
5	23205	1	#Max	16QAM	23.59	13.48
5	23205	12	#0	16QAM	22.32	12.21
5	23205	12	#Mid	16QAM	22.32	12.21
5	23205	12	#Max	16QAM	22.40	12.29
5	23205	25	#0	16QAM	22.40	12.29
5	23230	1	#0	QPSK	24.46	14.35
5	23230	1	#Mid	QPSK	24.65	14.54
5	23230	1	#Max	QPSK	24.43	14.32
5	23230	12	#0	QPSK	23.46	13.35
5	23230	12	#Mid	QPSK	23.45	13.34
5	23230	12	#Max	QPSK	23.48	13.37
5	23230	25	#0	QPSK	23.44	13.33
5	23230	1	#0	16QAM	23.64	13.53
5	23230	1	#Mid	16QAM	23.77	13.66
5	23230	1	#Max	16QAM	23.65	13.54
5	23230	12	#0	16QAM	22.45	12.34
5	23230	12	#Mid	16QAM	22.44	12.33
5	23230	12	#Max	16QAM	22.45	12.34
5	23230	25	#0	16QAM	22.42	12.31
5	23255	1	#0	QPSK	24.55	14.44

5	23255	1	#Mid	QPSK	24.64	14.53
5	23255	1	#Max	QPSK	24.54	14.43
5	23255	12	#0	QPSK	23.53	13.42
5	23255	12	#Mid	QPSK	23.50	13.39
5	23255	12	#Max	QPSK	23.50	13.39
5	23255	25	#0	QPSK	23.50	13.39
5	23255	1	#0	16QAM	23.68	13.57
5	23255	1	#Mid	16QAM	23.79	13.68
5	23255	1	#Max	16QAM	23.68	13.57
5	23255	12	#0	16QAM	22.45	12.34
5	23255	12	#Mid	16QAM	22.48	12.37
5	23255	12	#Max	16QAM	22.43	12.32
5	23255	25	#0	16QAM	22.50	12.39
10	23230	1	#0	QPSK	24.75	14.64
10	23230	1	#Mid	QPSK	24.70	14.59
10	23230	1	#Max	QPSK	24.69	14.58
10	23230	25	#0	QPSK	23.37	13.26
10	23230	25	#Mid	QPSK	23.38	13.27
10	23230	25	#Max	QPSK	23.43	13.32
10	23230	50	#0	QPSK	23.39	13.28
10	23230	1	#0	16QAM	23.42	13.31
10	23230	1	#Mid	16QAM	23.44	13.33
10	23230	1	#Max	16QAM	23.44	13.33
10	23230	25	#0	16QAM	22.34	12.23
10	23230	25	#Mid	16QAM	22.37	12.26
10	23230	25	#Max	16QAM	22.44	12.33
10	23230	50	#0	16QAM	22.37	12.26
5	23205	1	#0	64QAM	24.06	13.95
5	23205	1	#Mid	64QAM	24.16	14.05
5	23205	1	#Max	64QAM	24.03	13.92
5	23205	12	#0	64QAM	22.94	12.83
5	23205	12	#Mid	64QAM	22.95	12.84
5	23205	12	#Max	64QAM	23.00	12.89
5	23205	25	#0	64QAM	22.96	12.85
5	23230	1	#0	64QAM	24.07	13.96
5	23230	1	#Mid	64QAM	24.22	14.11
5	23230	1	#Max	64QAM	24.04	13.93
5	23230	12	#0	64QAM	23.02	12.91
5	23230	12	#Mid	64QAM	23.00	12.89
5	23230	12	#Max	64QAM	23.01	12.90
5	23230	25	#0	64QAM	22.98	12.87
5	23255	1	#0	64QAM	24.01	13.90
5	23255	1	#Mid	64QAM	24.13	14.02

5	23255	1	#Max	64QAM	23.96	13.85
5	23255	12	#0	64QAM	23.04	12.93
5	23255	12	#Mid	64QAM	23.05	12.94
5	23255	12	#Max	64QAM	22.99	12.88
5	23255	25	#0	64QAM	23.04	12.93
10	23230	1	#0	64QAM	22.94	12.83
10	23230	1	#Mid	64QAM	22.96	12.85
10	23230	1	#Max	64QAM	22.96	12.85
10	23230	25	#0	64QAM	21.85	11.74
10	23230	25	#Mid	64QAM	21.85	11.74
10	23230	25	#Max	64QAM	21.91	11.80
10	23230	50	#0	64QAM	21.88	11.77

LTE Band 17						
Bandwidth (MHz)	UL Channel	RB Size	RB Position	Modulation	Power (dBm)	ERP (dBm)
5	23755	1	#0	QPSK	24.14	14.03
5	23755	1	#Mid	QPSK	24.25	14.14
5	23755	1	#Max	QPSK	24.07	13.96
5	23755	12	#0	QPSK	23.09	12.98
5	23755	12	#Mid	QPSK	23.12	13.01
5	23755	12	#Max	QPSK	23.07	12.96
5	23755	25	#0	QPSK	23.06	12.95
5	23755	1	#0	16QAM	23.36	13.25
5	23755	1	#Mid	16QAM	23.44	13.33
5	23755	1	#Max	16QAM	23.30	13.19
5	23755	12	#0	16QAM	22.06	11.95
5	23755	12	#Mid	16QAM	22.03	11.92
5	23755	12	#Max	16QAM	21.98	11.87
5	23755	25	#0	16QAM	22.07	11.96
5	23790	1	#0	QPSK	24.10	13.99
5	23790	1	#Mid	QPSK	24.24	14.13
5	23790	1	#Max	QPSK	24.10	13.99
5	23790	12	#0	QPSK	23.11	13.00
5	23790	12	#Mid	QPSK	23.14	13.03
5	23790	12	#Max	QPSK	23.13	13.02
5	23790	25	#0	QPSK	23.10	12.99
5	23790	1	#0	16QAM	23.27	13.16
5	23790	1	#Mid	16QAM	23.36	13.25
5	23790	1	#Max	16QAM	23.23	13.12
5	23790	12	#0	16QAM	22.06	11.95
5	23790	12	#Mid	16QAM	22.09	11.98
5	23790	12	#Max	16QAM	22.10	11.99

5	23790	25	#0	16QAM	22.10	11.99
5	23825	1	#0	QPSK	24.01	13.90
5	23825	1	#Mid	QPSK	24.08	13.97
5	23825	1	#Max	QPSK	23.97	13.86
5	23825	12	#0	QPSK	22.95	12.84
5	23825	12	#Mid	QPSK	22.94	12.83
5	23825	12	#Max	QPSK	23.08	12.97
5	23825	25	#0	QPSK	23.02	12.91
5	23825	1	#0	16QAM	23.29	13.18
5	23825	1	#Mid	16QAM	23.34	13.23
5	23825	1	#Max	16QAM	23.15	13.04
5	23825	12	#0	16QAM	22.02	11.91
5	23825	12	#Mid	16QAM	22.00	11.89
5	23825	12	#Max	16QAM	22.08	11.97
5	23825	25	#0	16QAM	22.03	11.92
10	23780	1	#0	QPSK	24.18	14.07
10	23780	1	#Mid	QPSK	24.17	14.06
10	23780	1	#Max	QPSK	24.11	14.00
10	23780	25	#0	QPSK	23.23	13.12
10	23780	25	#Mid	QPSK	23.21	13.10
10	23780	25	#Max	QPSK	23.17	13.06
10	23780	50	#0	QPSK	23.17	13.06
10	23780	1	#0	16QAM	23.40	13.29
10	23780	1	#Mid	16QAM	23.40	13.29
10	23780	1	#Max	16QAM	23.36	13.25
10	23780	25	#0	16QAM	22.25	12.14
10	23780	25	#Mid	16QAM	22.26	12.15
10	23780	25	#Max	16QAM	22.24	12.13
10	23780	50	#0	16QAM	22.17	12.06
10	23790	1	#0	QPSK	24.15	14.04
10	23790	1	#Mid	QPSK	24.18	14.07
10	23790	1	#Max	QPSK	24.15	14.04
10	23790	25	#0	QPSK	23.22	13.11
10	23790	25	#Mid	QPSK	23.23	13.12
10	23790	25	#Max	QPSK	23.17	13.06
10	23790	50	#0	QPSK	23.19	13.08
10	23790	1	#0	16QAM	23.30	13.19
10	23790	1	#Mid	16QAM	23.34	13.23
10	23790	1	#Max	16QAM	23.25	13.14
10	23790	25	#0	16QAM	22.23	12.12
10	23790	25	#Mid	16QAM	22.27	12.16
10	23790	25	#Max	16QAM	22.26	12.15
10	23790	50	#0	16QAM	22.14	12.03

10	23800	1	#0	QPSK	24.27	14.16
10	23800	1	#Mid	QPSK	24.24	14.13
10	23800	1	#Max	QPSK	24.26	14.15
10	23800	25	#0	QPSK	23.22	13.11
10	23800	25	#Mid	QPSK	23.19	13.08
10	23800	25	#Max	QPSK	23.18	13.07
10	23800	50	#0	QPSK	23.14	13.03
10	23800	1	#0	16QAM	23.00	12.89
10	23800	1	#Mid	16QAM	23.05	12.94
10	23800	1	#Max	16QAM	22.92	12.81
10	23800	25	#0	16QAM	22.19	12.08
10	23800	25	#Mid	16QAM	22.18	12.07
10	23800	25	#Max	16QAM	22.21	12.10
10	23800	50	#0	16QAM	22.17	12.06
5	23755	1	#0	64QAM	23.65	13.54
5	23755	1	#Mid	64QAM	23.78	13.67
5	23755	1	#Max	64QAM	23.63	13.52
5	23755	12	#0	64QAM	22.63	12.52
5	23755	12	#Mid	64QAM	22.61	12.50
5	23755	12	#Max	64QAM	22.62	12.51
5	23755	25	#0	64QAM	22.57	12.46
5	23790	1	#0	64QAM	23.62	13.51
5	23790	1	#Mid	64QAM	23.73	13.62
5	23790	1	#Max	64QAM	23.59	13.48
5	23790	12	#0	64QAM	22.68	12.57
5	23790	12	#Mid	64QAM	22.67	12.56
5	23790	12	#Max	64QAM	22.70	12.59
5	23790	25	#0	64QAM	22.59	12.48
5	23825	1	#0	64QAM	23.56	13.45
5	23825	1	#Mid	64QAM	23.64	13.53
5	23825	1	#Max	64QAM	23.52	13.41
5	23825	12	#0	64QAM	22.45	12.34
5	23825	12	#Mid	64QAM	22.50	12.39
5	23825	12	#Max	64QAM	22.57	12.46
5	23825	25	#0	64QAM	22.48	12.37
10	23780	1	#0	64QAM	22.90	12.79
10	23780	1	#Mid	64QAM	22.89	12.78
10	23780	1	#Max	64QAM	22.86	12.75
10	23780	25	#0	64QAM	21.78	11.67
10	23780	25	#Mid	64QAM	21.79	11.68
10	23780	25	#Max	64QAM	21.76	11.65
10	23780	50	#0	64QAM	21.66	11.55
10	23790	1	#0	64QAM	22.85	12.74

10	23790	1	#Mid	64QAM	22.87	12.76
10	23790	1	#Max	64QAM	22.79	12.68
10	23790	25	#0	64QAM	21.72	11.61
10	23790	25	#Mid	64QAM	21.72	11.61
10	23790	25	#Max	64QAM	21.75	11.64
10	23790	50	#0	64QAM	21.68	11.57
10	23800	1	#0	64QAM	22.56	12.45
10	23800	1	#Mid	64QAM	22.61	12.50
10	23800	1	#Max	64QAM	22.47	12.36
10	23800	25	#0	64QAM	21.74	11.63
10	23800	25	#Mid	64QAM	21.71	11.60
10	23800	25	#Max	64QAM	21.70	11.59
10	23800	50	#0	64QAM	21.64	11.53

LTE Band 38						
Bandwidth (MHz)	UL Channel	RB Size	RB Position	Modulation	Power (dBm)	EIRP (dBm)
5	37775	1	#0	QPSK	24.47	23.01
5	37775	1	#Mid	QPSK	24.67	23.21
5	37775	1	#Max	QPSK	24.61	23.15
5	37775	12	#0	QPSK	23.56	22.10
5	37775	12	#Mid	QPSK	23.56	22.10
5	37775	12	#Max	QPSK	23.51	22.05
5	37775	25	#0	QPSK	23.54	22.08
5	37775	1	#0	16QAM	23.56	22.10
5	37775	1	#Mid	16QAM	23.67	22.21
5	37775	1	#Max	16QAM	23.51	22.05
5	37775	12	#0	16QAM	22.42	20.96
5	37775	12	#Mid	16QAM	22.39	20.93
5	37775	12	#Max	16QAM	22.39	20.93
5	37775	25	#0	16QAM	22.42	20.96
5	38000	1	#0	QPSK	24.57	23.11
5	38000	1	#Mid	QPSK	24.75	23.29
5	38000	1	#Max	QPSK	24.74	23.28
5	38000	12	#0	QPSK	23.35	21.89
5	38000	12	#Mid	QPSK	23.34	21.88
5	38000	12	#Max	QPSK	23.45	21.99
5	38000	25	#0	QPSK	23.34	21.88
5	38000	1	#0	16QAM	23.51	22.05
5	38000	1	#Mid	16QAM	23.69	22.23
5	38000	1	#Max	16QAM	23.64	22.18
5	38000	12	#0	16QAM	22.21	20.75
5	38000	12	#Mid	16QAM	22.22	20.76

5	38000	12	#Max	16QAM	22.25	20.79
5	38000	25	#0	16QAM	22.29	20.83
5	38225	1	#0	QPSK	24.92	23.46
5	38225	1	#Mid	QPSK	24.94	23.48
5	38225	1	#Max	QPSK	24.78	23.32
5	38225	12	#0	QPSK	23.88	22.42
5	38225	12	#Mid	QPSK	23.88	22.42
5	38225	12	#Max	QPSK	23.91	22.45
5	38225	25	#0	QPSK	23.82	22.36
5	38225	1	#0	16QAM	23.75	22.29
5	38225	1	#Mid	16QAM	23.93	22.47
5	38225	1	#Max	16QAM	23.82	22.36
5	38225	12	#0	16QAM	22.60	21.14
5	38225	12	#Mid	16QAM	22.59	21.13
5	38225	12	#Max	16QAM	22.65	21.19
5	38225	25	#0	16QAM	22.68	21.22
10	37800	1	#0	QPSK	24.67	23.21
10	37800	1	#Mid	QPSK	24.86	23.40
10	37800	1	#Max	QPSK	24.77	23.31
10	37800	25	#0	QPSK	23.57	22.11
10	37800	25	#Mid	QPSK	23.60	22.14
10	37800	25	#Max	QPSK	23.53	22.07
10	37800	50	#0	QPSK	23.52	22.06
10	37800	1	#0	16QAM	23.72	22.26
10	37800	1	#Mid	16QAM	23.68	22.22
10	37800	1	#Max	16QAM	23.58	22.12
10	37800	25	#0	16QAM	22.50	21.04
10	37800	25	#Mid	16QAM	22.50	21.04
10	37800	25	#Max	16QAM	22.46	21.00
10	37800	50	#0	16QAM	22.43	20.97
10	38000	1	#0	QPSK	24.60	23.14
10	38000	1	#Mid	QPSK	24.71	23.25
10	38000	1	#Max	QPSK	24.86	23.40
10	38000	25	#0	QPSK	23.33	21.87
10	38000	25	#Mid	QPSK	23.34	21.88
10	38000	25	#Max	QPSK	23.46	22.00
10	38000	50	#0	QPSK	23.42	21.96
10	38000	1	#0	16QAM	23.28	21.82
10	38000	1	#Mid	16QAM	23.43	21.97
10	38000	1	#Max	16QAM	23.59	22.13
10	38000	25	#0	16QAM	22.26	20.80
10	38000	25	#Mid	16QAM	22.27	20.81
10	38000	25	#Max	16QAM	22.39	20.93

10	38000	50	#0	16QAM	22.32	20.86
10	38200	1	#0	QPSK	24.84	23.38
10	38200	1	#Mid	QPSK	24.86	23.40
10	38200	1	#Max	QPSK	24.69	23.23
10	38200	25	#0	QPSK	23.83	22.37
10	38200	25	#Mid	QPSK	23.84	22.38
10	38200	25	#Max	QPSK	23.83	22.37
10	38200	50	#0	QPSK	23.79	22.33
10	38200	1	#0	16QAM	23.52	22.06
10	38200	1	#Mid	16QAM	23.60	22.14
10	38200	1	#Max	16QAM	23.63	22.17
10	38200	25	#0	16QAM	22.67	21.21
10	38200	25	#Mid	16QAM	22.70	21.24
10	38200	25	#Max	16QAM	22.69	21.23
10	38200	50	#0	16QAM	22.68	21.22
15	37825	1	#0	QPSK	24.80	23.34
15	37825	1	#Mid	QPSK	24.82	23.36
15	37825	1	#Max	QPSK	24.62	23.16
15	37825	36	#0	QPSK	23.78	22.32
15	37825	36	#Mid	QPSK	23.77	22.31
15	37825	36	#Max	QPSK	23.70	22.24
15	37825	75	#0	QPSK	23.71	22.25
15	37825	1	#0	16QAM	23.49	22.03
15	37825	1	#Mid	16QAM	23.52	22.06
15	37825	1	#Max	16QAM	23.33	21.87
15	37825	36	#0	16QAM	22.57	21.11
15	37825	36	#Mid	16QAM	22.59	21.13
15	37825	36	#Max	16QAM	22.54	21.08
15	37825	75	#0	16QAM	22.53	21.07
15	38000	1	#0	QPSK	24.68	23.22
15	38000	1	#Mid	QPSK	24.90	23.44
15	38000	1	#Max	QPSK	25.03	23.57
15	38000	36	#0	QPSK	23.55	22.09
15	38000	36	#Mid	QPSK	23.53	22.07
15	38000	36	#Max	QPSK	23.76	22.30
15	38000	75	#0	QPSK	23.64	22.18
15	38000	1	#0	16QAM	23.08	21.62
15	38000	1	#Mid	16QAM	23.30	21.84
15	38000	1	#Max	16QAM	23.43	21.97
15	38000	36	#0	16QAM	22.36	20.90
15	38000	36	#Mid	16QAM	22.39	20.93
15	38000	36	#Max	16QAM	22.57	21.11
15	38000	75	#0	16QAM	22.52	21.06

15	38175	1	#0	QPSK	24.89	23.43
15	38175	1	#Mid	QPSK	24.97	23.51
15	38175	1	#Max	QPSK	24.78	23.32
15	38175	36	#0	QPSK	24.03	22.57
15	38175	36	#Mid	QPSK	24.03	22.57
15	38175	36	#Max	QPSK	24.15	22.69
15	38175	75	#0	QPSK	24.06	22.60
15	38175	1	#0	16QAM	23.65	22.19
15	38175	1	#Mid	16QAM	23.88	22.42
15	38175	1	#Max	16QAM	23.84	22.38
15	38175	36	#0	16QAM	22.82	21.36
15	38175	36	#Mid	16QAM	22.82	21.36
15	38175	36	#Max	16QAM	22.93	21.47
15	38175	75	#0	16QAM	22.85	21.39
20	37850	1	#0	QPSK	24.66	23.20
20	37850	1	#Mid	QPSK	24.68	23.22
20	37850	1	#Max	QPSK	24.48	23.02
20	37850	50	#0	QPSK	23.41	21.95
20	37850	50	#Mid	QPSK	23.40	21.94
20	37850	50	#Max	QPSK	23.40	21.94
20	37850	100	#0	QPSK	23.41	21.95
20	37850	1	#0	16QAM	23.04	21.58
20	37850	1	#Mid	16QAM	23.09	21.63
20	37850	1	#Max	16QAM	22.87	21.41
20	37850	50	#0	16QAM	22.38	20.92
20	37850	50	#Mid	16QAM	22.37	20.91
20	37850	50	#Max	16QAM	22.35	20.89
20	37850	100	#0	16QAM	22.32	20.86
20	38000	1	#0	QPSK	24.47	23.01
20	38000	1	#Mid	QPSK	24.77	23.31
20	38000	1	#Max	QPSK	24.87	23.41
20	38000	50	#0	QPSK	23.23	21.77
20	38000	50	#Mid	QPSK	23.25	21.79
20	38000	50	#Max	QPSK	23.51	22.05
20	38000	100	#0	QPSK	23.36	21.90
20	38000	1	#0	16QAM	23.18	21.72
20	38000	1	#Mid	16QAM	23.46	22.00
20	38000	1	#Max	16QAM	23.60	22.14
20	38000	50	#0	16QAM	22.21	20.75
20	38000	50	#Mid	16QAM	22.20	20.74
20	38000	50	#Max	16QAM	22.46	21.00
20	38000	100	#0	16QAM	22.29	20.83
20	38150	1	#0	QPSK	24.82	23.36

20	38150	1	#Mid	QPSK	25.14	23.68
20	38150	1	#Max	QPSK	24.84	23.38
20	38150	50	#0	QPSK	23.60	22.14
20	38150	50	#Mid	QPSK	23.61	22.15
20	38150	50	#Max	QPSK	23.78	22.32
20	38150	100	#0	QPSK	23.67	22.21
20	38150	1	#0	16QAM	23.14	21.68
20	38150	1	#Mid	16QAM	23.65	22.19
20	38150	1	#Max	16QAM	23.55	22.09
20	38150	50	#0	16QAM	22.48	21.02
20	38150	50	#Mid	16QAM	22.50	21.04
20	38150	50	#Max	16QAM	22.67	21.21
20	38150	100	#0	16QAM	22.56	21.10
5	37775	1	#0	64QAM	24.00	22.54
5	37775	1	#Mid	64QAM	24.21	22.75
5	37775	1	#Max	64QAM	24.07	22.61
5	37775	12	#0	64QAM	22.99	21.53
5	37775	12	#Mid	64QAM	23.01	21.55
5	37775	12	#Max	64QAM	22.99	21.53
5	37775	25	#0	64QAM	23.00	21.54
5	38000	1	#0	64QAM	23.99	22.53
5	38000	1	#Mid	64QAM	24.20	22.74
5	38000	1	#Max	64QAM	24.17	22.71
5	38000	12	#0	64QAM	22.81	21.35
5	38000	12	#Mid	64QAM	22.79	21.33
5	38000	12	#Max	64QAM	22.89	21.43
5	38000	25	#0	64QAM	22.83	21.37
5	38225	1	#0	64QAM	24.39	22.93
5	38225	1	#Mid	64QAM	24.44	22.98
5	38225	1	#Max	64QAM	24.29	22.83
5	38225	12	#0	64QAM	23.31	21.85
5	38225	12	#Mid	64QAM	23.31	21.85
5	38225	12	#Max	64QAM	23.34	21.88
5	38225	25	#0	64QAM	23.26	21.80
10	37800	1	#0	64QAM	23.19	21.73
10	37800	1	#Mid	64QAM	23.13	21.67
10	37800	1	#Max	64QAM	23.07	21.61
10	37800	25	#0	64QAM	21.96	20.50
10	37800	25	#Mid	64QAM	21.96	20.50
10	37800	25	#Max	64QAM	21.93	20.47
10	37800	50	#0	64QAM	21.91	20.45
10	38000	1	#0	64QAM	22.75	21.29
10	38000	1	#Mid	64QAM	22.87	21.41

10	38000	1	#Max	64QAM	23.01	21.55
10	38000	25	#0	64QAM	21.73	20.27
10	38000	25	#Mid	64QAM	21.72	20.26
10	38000	25	#Max	64QAM	21.90	20.44
10	38000	50	#0	64QAM	21.76	20.30
10	38200	1	#0	64QAM	22.99	21.53
10	38200	1	#Mid	64QAM	23.02	21.56
10	38200	1	#Max	64QAM	23.06	21.60
10	38200	25	#0	64QAM	22.13	20.67
10	38200	25	#Mid	64QAM	22.13	20.67
10	38200	25	#Max	64QAM	22.12	20.66
10	38200	50	#0	64QAM	22.13	20.67
15	37825	1	#0	64QAM	23.07	21.61
15	37825	1	#Mid	64QAM	23.08	21.62
15	37825	1	#Max	64QAM	22.92	21.46
15	37825	36	#0	64QAM	22.05	20.59
15	37825	36	#Mid	64QAM	22.06	20.60
15	37825	36	#Max	64QAM	21.99	20.53
15	37825	75	#0	64QAM	22.00	20.54
15	38000	1	#0	64QAM	22.62	21.16
15	38000	1	#Mid	64QAM	22.82	21.36
15	38000	1	#Max	64QAM	23.01	21.55
15	38000	36	#0	64QAM	21.84	20.38
15	38000	36	#Mid	64QAM	21.84	20.38
15	38000	36	#Max	64QAM	22.06	20.60
15	38000	75	#0	64QAM	21.91	20.45
15	38175	1	#0	64QAM	22.94	21.48
15	38175	1	#Mid	64QAM	23.20	21.74
15	38175	1	#Max	64QAM	23.16	21.70
15	38175	36	#0	64QAM	22.22	20.76
15	38175	36	#Mid	64QAM	22.22	20.76
15	38175	36	#Max	64QAM	22.35	20.89
15	38175	75	#0	64QAM	22.33	20.87
20	37850	1	#0	64QAM	22.66	21.20
20	37850	1	#Mid	64QAM	22.70	21.24
20	37850	1	#Max	64QAM	22.51	21.05
20	37850	50	#0	64QAM	21.80	20.34
20	37850	50	#Mid	64QAM	21.80	20.34
20	37850	50	#Max	64QAM	21.77	20.31
20	37850	100	#0	64QAM	21.79	20.33
20	38000	1	#0	64QAM	22.20	20.74
20	38000	1	#Mid	64QAM	22.49	21.03
20	38000	1	#Max	64QAM	22.61	21.15

20	38000	50	#0	64QAM	21.68	20.22
20	38000	50	#Mid	64QAM	21.68	20.22
20	38000	50	#Max	64QAM	21.94	20.48
20	38000	100	#0	64QAM	21.75	20.29
20	38150	1	#0	64QAM	22.85	21.39
20	38150	1	#Mid	64QAM	23.34	21.88
20	38150	1	#Max	64QAM	23.23	21.77
20	38150	50	#0	64QAM	21.95	20.49
20	38150	50	#Mid	64QAM	21.96	20.50
20	38150	50	#Max	64QAM	22.09	20.63
20	38150	100	#0	64QAM	21.98	20.52

LTE Band 41						
Bandwidth (MHz)	UL Channel	RB Size	RB Position	Modulation	Power (dBm)	EIRP (dBm)
5	39675	1	#0	QPSK	24.89	23.63
5	39675	1	#Mid	QPSK	25.04	23.78
5	39675	1	#Max	QPSK	24.92	23.66
5	39675	12	#0	QPSK	23.69	22.43
5	39675	12	#Mid	QPSK	23.70	22.44
5	39675	12	#Max	QPSK	23.73	22.47
5	39675	25	#0	QPSK	23.77	22.51
5	39675	1	#0	16QAM	23.75	22.49
5	39675	1	#Mid	16QAM	23.91	22.65
5	39675	1	#Max	16QAM	23.80	22.54
5	39675	12	#0	16QAM	22.67	21.41
5	39675	12	#Mid	16QAM	22.60	21.34
5	39675	12	#Max	16QAM	22.66	21.40
5	39675	25	#0	16QAM	22.67	21.41
5	40620	1	#0	QPSK	24.56	23.30
5	40620	1	#Mid	QPSK	24.69	23.43
5	40620	1	#Max	QPSK	24.66	23.40
5	40620	12	#0	QPSK	23.37	22.11
5	40620	12	#Mid	QPSK	23.36	22.10
5	40620	12	#Max	QPSK	23.38	22.12
5	40620	25	#0	QPSK	23.33	22.07
5	40620	1	#0	16QAM	23.52	22.26
5	40620	1	#Mid	16QAM	23.63	22.37
5	40620	1	#Max	16QAM	23.60	22.34
5	40620	12	#0	16QAM	22.20	20.94
5	40620	12	#Mid	16QAM	22.22	20.96
5	40620	12	#Max	16QAM	22.21	20.95
5	40620	25	#0	16QAM	22.25	20.99

5	41565	1	#0	QPSK	23.12	21.86
5	41565	1	#Mid	QPSK	23.17	21.91
5	41565	1	#Max	QPSK	23.06	21.80
5	41565	12	#0	QPSK	23.10	21.84
5	41565	12	#Mid	QPSK	23.08	21.82
5	41565	12	#Max	QPSK	23.08	21.82
5	41565	25	#0	QPSK	23.05	21.79
5	41565	1	#0	16QAM	22.68	21.42
5	41565	1	#Mid	16QAM	22.78	21.52
5	41565	1	#Max	16QAM	22.69	21.43
5	41565	12	#0	16QAM	22.73	21.47
5	41565	12	#Mid	16QAM	22.72	21.46
5	41565	12	#Max	16QAM	22.73	21.47
5	41565	25	#0	16QAM	22.70	21.44
10	39700	1	#0	QPSK	25.03	23.77
10	39700	1	#Mid	QPSK	25.07	23.81
10	39700	1	#Max	QPSK	25.01	23.75
10	39700	25	#0	QPSK	23.80	22.54
10	39700	25	#Mid	QPSK	23.80	22.54
10	39700	25	#Max	QPSK	23.84	22.58
10	39700	50	#0	QPSK	23.79	22.53
10	39700	1	#0	16QAM	23.77	22.51
10	39700	1	#Mid	16QAM	23.82	22.56
10	39700	1	#Max	16QAM	23.81	22.55
10	39700	25	#0	16QAM	22.64	21.38
10	39700	25	#Mid	16QAM	22.68	21.42
10	39700	25	#Max	16QAM	22.76	21.50
10	39700	50	#0	16QAM	22.68	21.42
10	40620	1	#0	QPSK	24.67	23.41
10	40620	1	#Mid	QPSK	24.69	23.43
10	40620	1	#Max	QPSK	24.84	23.58
10	40620	25	#0	QPSK	23.33	22.07
10	40620	25	#Mid	QPSK	23.34	22.08
10	40620	25	#Max	QPSK	23.42	22.16
10	40620	50	#0	QPSK	23.36	22.10
10	40620	1	#0	16QAM	23.05	21.79
10	40620	1	#Mid	16QAM	23.09	21.83
10	40620	1	#Max	16QAM	23.23	21.97
10	40620	25	#0	16QAM	22.25	20.99
10	40620	25	#Mid	16QAM	22.26	21.00
10	40620	25	#Max	16QAM	22.33	21.07
10	40620	50	#0	16QAM	22.29	21.03
10	41540	1	#0	QPSK	23.13	21.87

10	41540	1	#Mid	QPSK	23.13	21.87
10	41540	1	#Max	QPSK	23.01	21.75
10	41540	25	#0	QPSK	23.10	21.84
10	41540	25	#Mid	QPSK	23.08	21.82
10	41540	25	#Max	QPSK	23.07	21.81
10	41540	50	#0	QPSK	23.02	21.76
10	41540	1	#0	16QAM	22.77	21.51
10	41540	1	#Mid	16QAM	22.79	21.53
10	41540	1	#Max	16QAM	22.70	21.44
10	41540	25	#0	16QAM	22.82	21.56
10	41540	25	#Mid	16QAM	22.81	21.55
10	41540	25	#Max	16QAM	22.80	21.54
10	41540	50	#0	16QAM	22.74	21.48
15	39725	1	#0	QPSK	25.03	23.77
15	39725	1	#Mid	QPSK	25.17	23.91
15	39725	1	#Max	QPSK	24.93	23.67
15	39725	36	#0	QPSK	23.91	22.65
15	39725	36	#Mid	QPSK	23.89	22.63
15	39725	36	#Max	QPSK	23.98	22.72
15	39725	75	#0	QPSK	24.02	22.76
15	39725	1	#0	16QAM	23.75	22.49
15	39725	1	#Mid	16QAM	23.91	22.65
15	39725	1	#Max	16QAM	23.83	22.57
15	39725	36	#0	16QAM	22.80	21.54
15	39725	36	#Mid	16QAM	22.80	21.54
15	39725	36	#Max	16QAM	22.89	21.63
15	39725	75	#0	16QAM	22.86	21.60
15	40620	1	#0	QPSK	24.52	23.26
15	40620	1	#Mid	QPSK	24.62	23.36
15	40620	1	#Max	QPSK	24.75	23.49
15	40620	36	#0	QPSK	23.54	22.28
15	40620	36	#Mid	QPSK	23.53	22.27
15	40620	36	#Max	QPSK	23.69	22.43
15	40620	75	#0	QPSK	23.63	22.37
15	40620	1	#0	16QAM	23.21	21.95
15	40620	1	#Mid	16QAM	23.33	22.07
15	40620	1	#Max	16QAM	23.44	22.18
15	40620	36	#0	16QAM	22.38	21.12
15	40620	36	#Mid	16QAM	22.40	21.14
15	40620	36	#Max	16QAM	22.53	21.27
15	40620	75	#0	16QAM	22.46	21.20
15	41515	1	#0	QPSK	23.29	22.03
15	41515	1	#Mid	QPSK	23.27	22.01

15	41515	1	#Max	QPSK	23.12	21.86
15	41515	36	#0	QPSK	23.07	21.81
15	41515	36	#Mid	QPSK	23.05	21.79
15	41515	36	#Max	QPSK	22.99	21.73
15	41515	75	#0	QPSK	22.97	21.71
15	41515	1	#0	16QAM	22.64	21.38
15	41515	1	#Mid	16QAM	22.70	21.44
15	41515	1	#Max	16QAM	22.57	21.31
15	41515	36	#0	16QAM	22.76	21.50
15	41515	36	#Mid	16QAM	22.76	21.50
15	41515	36	#Max	16QAM	22.71	21.45
15	41515	75	#0	16QAM	22.72	21.46
20	39750	1	#0	QPSK	24.78	23.52
20	39750	1	#Mid	QPSK	24.89	23.63
20	39750	1	#Max	QPSK	24.55	23.29
20	39750	50	#0	QPSK	23.71	22.45
20	39750	50	#Mid	QPSK	23.72	22.46
20	39750	50	#Max	QPSK	23.81	22.55
20	39750	100	#0	QPSK	23.72	22.46
20	39750	1	#0	16QAM	23.59	22.33
20	39750	1	#Mid	16QAM	23.83	22.57
20	39750	1	#Max	16QAM	23.64	22.38
20	39750	50	#0	16QAM	22.58	21.32
20	39750	50	#Mid	16QAM	22.60	21.34
20	39750	50	#Max	16QAM	22.70	21.44
20	39750	100	#0	16QAM	22.61	21.35
20	40620	1	#0	QPSK	24.64	23.38
20	40620	1	#Mid	QPSK	24.82	23.56
20	40620	1	#Max	QPSK	24.83	23.57
20	40620	50	#0	QPSK	23.31	22.05
20	40620	50	#Mid	QPSK	23.31	22.05
20	40620	50	#Max	QPSK	23.46	22.20
20	40620	100	#0	QPSK	23.36	22.10
20	40620	1	#0	16QAM	22.98	21.72
20	40620	1	#Mid	16QAM	23.15	21.89
20	40620	1	#Max	16QAM	23.27	22.01
20	40620	50	#0	16QAM	22.20	20.94
20	40620	50	#Mid	16QAM	22.21	20.95
20	40620	50	#Max	16QAM	22.36	21.10
20	40620	100	#0	16QAM	22.31	21.05
20	41490	1	#0	QPSK	23.02	21.76
20	41490	1	#Mid	QPSK	23.09	21.83
20	41490	1	#Max	QPSK	22.82	21.56

20	41490	50	#0	QPSK	23.16	21.90
20	41490	50	#Mid	QPSK	23.13	21.87
20	41490	50	#Max	QPSK	23.09	21.83
20	41490	100	#0	QPSK	23.05	21.79
20	41490	1	#0	16QAM	22.33	21.07
20	41490	1	#Mid	16QAM	22.50	21.24
20	41490	1	#Max	16QAM	22.21	20.95
20	41490	50	#0	16QAM	22.90	21.64
20	41490	50	#Mid	16QAM	22.88	21.62
20	41490	50	#Max	16QAM	22.82	21.56
20	41490	100	#0	16QAM	22.79	21.53
5	39675	1	#0	64QAM	24.32	23.06
5	39675	1	#Mid	64QAM	24.49	23.23
5	39675	1	#Max	64QAM	24.34	23.08
5	39675	12	#0	64QAM	23.12	21.86
5	39675	12	#Mid	64QAM	23.13	21.87
5	39675	12	#Max	64QAM	23.17	21.91
5	39675	25	#0	64QAM	23.20	21.94
5	40620	1	#0	64QAM	23.99	22.73
5	40620	1	#Mid	64QAM	24.12	22.86
5	40620	1	#Max	64QAM	24.10	22.84
5	40620	12	#0	64QAM	22.81	21.55
5	40620	12	#Mid	64QAM	22.80	21.54
5	40620	12	#Max	64QAM	22.82	21.56
5	40620	25	#0	64QAM	22.78	21.52
5	41565	1	#0	64QAM	22.62	21.36
5	41565	1	#Mid	64QAM	22.69	21.43
5	41565	1	#Max	64QAM	22.58	21.32
5	41565	12	#0	64QAM	22.61	21.35
5	41565	12	#Mid	64QAM	22.59	21.33
5	41565	12	#Max	64QAM	22.59	21.33
5	41565	25	#0	64QAM	22.57	21.31
10	39700	1	#0	64QAM	23.30	22.04
10	39700	1	#Mid	64QAM	23.37	22.11
10	39700	1	#Max	64QAM	23.37	22.11
10	39700	25	#0	64QAM	22.14	20.88
10	39700	25	#Mid	64QAM	22.13	20.87
10	39700	25	#Max	64QAM	22.23	20.97
10	39700	50	#0	64QAM	22.11	20.85
10	40620	1	#0	64QAM	22.77	21.51
10	40620	1	#Mid	64QAM	22.79	21.53
10	40620	1	#Max	64QAM	22.93	21.67
10	40620	25	#0	64QAM	21.74	20.48

10	40620	25	#Mid	64QAM	21.71	20.45
10	40620	25	#Max	64QAM	21.80	20.54
10	40620	50	#0	64QAM	21.71	20.45
10	41540	1	#0	64QAM	22.25	20.99
10	41540	1	#Mid	64QAM	22.24	20.98
10	41540	1	#Max	64QAM	22.10	20.84
10	41540	25	#0	64QAM	22.41	21.15
10	41540	25	#Mid	64QAM	22.39	21.13
10	41540	25	#Max	64QAM	22.37	21.11
10	41540	50	#0	64QAM	22.35	21.09
15	39725	1	#0	64QAM	23.19	21.93
15	39725	1	#Mid	64QAM	23.37	22.11
15	39725	1	#Max	64QAM	23.30	22.04
15	39725	36	#0	64QAM	22.28	21.02
15	39725	36	#Mid	64QAM	22.30	21.04
15	39725	36	#Max	64QAM	22.35	21.09
15	39725	75	#0	64QAM	22.27	21.01
15	40620	1	#0	64QAM	22.67	21.41
15	40620	1	#Mid	64QAM	22.78	21.52
15	40620	1	#Max	64QAM	22.89	21.63
15	40620	36	#0	64QAM	21.84	20.58
15	40620	36	#Mid	64QAM	21.84	20.58
15	40620	36	#Max	64QAM	21.96	20.70
15	40620	75	#0	64QAM	21.89	20.63
15	41515	1	#0	64QAM	22.40	21.14
15	41515	1	#Mid	64QAM	22.38	21.12
15	41515	1	#Max	64QAM	22.21	20.95
15	41515	36	#0	64QAM	22.39	21.13
15	41515	36	#Mid	64QAM	22.37	21.11
15	41515	36	#Max	64QAM	22.30	21.04
15	41515	75	#0	64QAM	22.30	21.04
20	39750	1	#0	64QAM	22.83	21.57
20	39750	1	#Mid	64QAM	23.07	21.81
20	39750	1	#Max	64QAM	22.87	21.61
20	39750	50	#0	64QAM	22.03	20.77
20	39750	50	#Mid	64QAM	22.02	20.76
20	39750	50	#Max	64QAM	22.14	20.88
20	39750	100	#0	64QAM	22.09	20.83
20	40620	1	#0	64QAM	22.27	21.01
20	40620	1	#Mid	64QAM	22.45	21.19
20	40620	1	#Max	64QAM	22.54	21.28
20	40620	50	#0	64QAM	21.69	20.43
20	40620	50	#Mid	64QAM	21.70	20.44

20	40620	50	#Max	64QAM	21.86	20.60
20	40620	100	#0	64QAM	21.75	20.49
20	41490	1	#0	64QAM	22.55	21.29
20	41490	1	#Mid	64QAM	22.57	21.31
20	41490	1	#Max	64QAM	22.26	21.00
20	41490	50	#0	64QAM	22.36	21.10
20	41490	50	#Mid	64QAM	22.35	21.09
20	41490	50	#Max	64QAM	22.45	21.19
20	41490	100	#0	64QAM	22.40	21.14

LTE Band 66						
Bandwidth (MHz)	UL Channel	RB Size	RB Position	Modulation	Power (dBm)	EIRP (dBm)
1.4	131979	1	#0	QPSK	24.61	24.07
1.4	131979	1	#Mid	QPSK	24.71	24.17
1.4	131979	1	#Max	QPSK	24.74	24.20
1.4	131979	3	#0	QPSK	24.42	23.88
1.4	131979	3	#Mid	QPSK	24.43	23.89
1.4	131979	3	#Max	QPSK	24.42	23.88
1.4	131979	6	#0	QPSK	23.66	23.12
1.4	131979	1	#0	16QAM	23.35	22.81
1.4	131979	1	#Mid	16QAM	23.41	22.87
1.4	131979	1	#Max	16QAM	23.41	22.87
1.4	131979	3	#0	16QAM	23.44	22.90
1.4	131979	3	#Mid	16QAM	23.44	22.90
1.4	131979	3	#Max	16QAM	23.45	22.91
1.4	131979	6	#0	16QAM	22.60	22.06
1.4	132322	1	#0	QPSK	24.29	23.75
1.4	132322	1	#Mid	QPSK	24.32	23.78
1.4	132322	1	#Max	QPSK	24.30	23.76
1.4	132322	3	#0	QPSK	24.24	23.70
1.4	132322	3	#Mid	QPSK	24.24	23.70
1.4	132322	3	#Max	QPSK	24.21	23.67
1.4	132322	6	#0	QPSK	23.45	22.91
1.4	132322	1	#0	16QAM	23.30	22.76
1.4	132322	1	#Mid	16QAM	23.35	22.81
1.4	132322	1	#Max	16QAM	23.36	22.82
1.4	132322	3	#0	16QAM	23.18	22.64
1.4	132322	3	#Mid	16QAM	23.20	22.66
1.4	132322	3	#Max	16QAM	23.22	22.68
1.4	132322	6	#0	16QAM	22.38	21.84
1.4	132665	1	#0	QPSK	24.43	23.89
1.4	132665	1	#Mid	QPSK	24.41	23.87

1.4	132665	1	#Max	QPSK	24.43	23.89
1.4	132665	3	#0	QPSK	24.15	23.61
1.4	132665	3	#Mid	QPSK	24.13	23.59
1.4	132665	3	#Max	QPSK	24.09	23.55
1.4	132665	6	#0	QPSK	23.37	22.83
1.4	132665	1	#0	16QAM	23.01	22.47
1.4	132665	1	#Mid	16QAM	23.01	22.47
1.4	132665	1	#Max	16QAM	23.03	22.49
1.4	132665	3	#0	16QAM	22.98	22.44
1.4	132665	3	#Mid	16QAM	23.00	22.46
1.4	132665	3	#Max	16QAM	22.95	22.41
1.4	132665	6	#0	16QAM	22.27	21.73
3	131987	1	#0	QPSK	24.37	23.83
3	131987	1	#Mid	QPSK	24.56	24.02
3	131987	1	#Max	QPSK	24.47	23.93
3	131987	8	#0	QPSK	23.49	22.95
3	131987	8	#Mid	QPSK	23.50	22.96
3	131987	8	#Max	QPSK	23.61	23.07
3	131987	15	#0	QPSK	23.46	22.92
3	131987	1	#0	16QAM	23.40	22.86
3	131987	1	#Mid	16QAM	23.58	23.04
3	131987	1	#Max	16QAM	23.51	22.97
3	131987	8	#0	16QAM	22.44	21.90
3	131987	8	#Mid	16QAM	22.45	21.91
3	131987	8	#Max	16QAM	22.54	22.00
3	131987	15	#0	16QAM	22.45	21.91
3	132322	1	#0	QPSK	24.13	23.59
3	132322	1	#Mid	QPSK	24.31	23.77
3	132322	1	#Max	QPSK	24.19	23.65
3	132322	8	#0	QPSK	23.29	22.75
3	132322	8	#Mid	QPSK	23.29	22.75
3	132322	8	#Max	QPSK	23.38	22.84
3	132322	15	#0	QPSK	23.28	22.74
3	132322	1	#0	16QAM	23.20	22.66
3	132322	1	#Mid	16QAM	23.28	22.74
3	132322	1	#Max	16QAM	23.26	22.72
3	132322	8	#0	16QAM	22.24	21.70
3	132322	8	#Mid	16QAM	22.27	21.73
3	132322	8	#Max	16QAM	22.31	21.77
3	132322	15	#0	16QAM	22.24	21.70
3	132657	1	#0	QPSK	24.24	23.70
3	132657	1	#Mid	QPSK	24.43	23.89
3	132657	1	#Max	QPSK	24.29	23.75

3	132657	8	#0	QPSK	23.28	22.74
3	132657	8	#Mid	QPSK	23.28	22.74
3	132657	8	#Max	QPSK	23.29	22.75
3	132657	15	#0	QPSK	23.22	22.68
3	132657	1	#0	16QAM	22.83	22.29
3	132657	1	#Mid	16QAM	22.98	22.44
3	132657	1	#Max	16QAM	22.88	22.34
3	132657	8	#0	16QAM	22.18	21.64
3	132657	8	#Mid	16QAM	22.17	21.63
3	132657	8	#Max	16QAM	22.18	21.64
3	132657	15	#0	16QAM	22.16	21.62
5	131997	1	#0	QPSK	24.57	24.03
5	131997	1	#Mid	QPSK	24.79	24.25
5	131997	1	#Max	QPSK	24.73	24.19
5	131997	12	#0	QPSK	23.55	23.01
5	131997	12	#Mid	QPSK	23.51	22.97
5	131997	12	#Max	QPSK	23.67	23.13
5	131997	25	#0	QPSK	23.49	22.95
5	131997	1	#0	16QAM	23.64	23.10
5	131997	1	#Mid	16QAM	23.85	23.31
5	131997	1	#Max	16QAM	23.77	23.23
5	131997	12	#0	16QAM	22.45	21.91
5	131997	12	#Mid	16QAM	22.47	21.93
5	131997	12	#Max	16QAM	22.57	22.03
5	131997	25	#0	16QAM	22.55	22.01
5	132322	1	#0	QPSK	24.42	23.88
5	132322	1	#Mid	QPSK	24.57	24.03
5	132322	1	#Max	QPSK	24.49	23.95
5	132322	12	#0	QPSK	23.34	22.80
5	132322	12	#Mid	QPSK	23.35	22.81
5	132322	12	#Max	QPSK	23.39	22.85
5	132322	25	#0	QPSK	23.35	22.81
5	132322	1	#0	16QAM	23.44	22.90
5	132322	1	#Mid	16QAM	23.52	22.98
5	132322	1	#Max	16QAM	23.47	22.93
5	132322	12	#0	16QAM	22.28	21.74
5	132322	12	#Mid	16QAM	22.27	21.73
5	132322	12	#Max	16QAM	22.35	21.81
5	132322	25	#0	16QAM	22.37	21.83
5	132647	1	#0	QPSK	24.23	23.69
5	132647	1	#Mid	QPSK	24.44	23.90
5	132647	1	#Max	QPSK	24.29	23.75
5	132647	12	#0	QPSK	23.26	22.72

5	132647	12	#Mid	QPSK	23.28	22.74
5	132647	12	#Max	QPSK	23.21	22.67
5	132647	25	#0	QPSK	23.24	22.70
5	132647	1	#0	16QAM	23.33	22.79
5	132647	1	#Mid	16QAM	23.46	22.92
5	132647	1	#Max	16QAM	23.36	22.82
5	132647	12	#0	16QAM	22.24	21.70
5	132647	12	#Mid	16QAM	22.24	21.70
5	132647	12	#Max	16QAM	22.23	21.69
5	132647	25	#0	16QAM	22.25	21.71
10	132022	1	#0	QPSK	24.70	24.16
10	132022	1	#Mid	QPSK	24.82	24.28
10	132022	1	#Max	QPSK	24.89	24.35
10	132022	25	#0	QPSK	23.52	22.98
10	132022	25	#Mid	QPSK	23.49	22.95
10	132022	25	#Max	QPSK	23.77	23.23
10	132022	50	#0	QPSK	23.59	23.05
10	132022	1	#0	16QAM	23.66	23.12
10	132022	1	#Mid	16QAM	23.79	23.25
10	132022	1	#Max	16QAM	23.89	23.35
10	132022	25	#0	16QAM	22.54	22.00
10	132022	25	#Mid	16QAM	22.56	22.02
10	132022	25	#Max	16QAM	22.78	22.24
10	132022	50	#0	16QAM	22.61	22.07
10	132322	1	#0	QPSK	24.51	23.97
10	132322	1	#Mid	QPSK	24.49	23.95
10	132322	1	#Max	QPSK	24.59	24.05
10	132322	25	#0	QPSK	23.31	22.77
10	132322	25	#Mid	QPSK	23.35	22.81
10	132322	25	#Max	QPSK	23.40	22.86
10	132322	50	#0	QPSK	23.36	22.82
10	132322	1	#0	16QAM	23.52	22.98
10	132322	1	#Mid	16QAM	23.53	22.99
10	132322	1	#Max	16QAM	23.60	23.06
10	132322	25	#0	16QAM	22.37	21.83
10	132322	25	#Mid	16QAM	22.36	21.82
10	132322	25	#Max	16QAM	22.45	21.91
10	132322	50	#0	16QAM	22.35	21.81
10	132622	1	#0	QPSK	24.52	23.98
10	132622	1	#Mid	QPSK	24.46	23.92
10	132622	1	#Max	QPSK	24.54	24.00
10	132622	25	#0	QPSK	23.26	22.72
10	132622	25	#Mid	QPSK	23.23	22.69

10	132622	25	#Max	QPSK	23.18	22.64
10	132622	50	#0	QPSK	23.19	22.65
10	132622	1	#0	16QAM	23.11	22.57
10	132622	1	#Mid	16QAM	23.09	22.55
10	132622	1	#Max	16QAM	23.11	22.57
10	132622	25	#0	16QAM	22.23	21.69
10	132622	25	#Mid	16QAM	22.26	21.72
10	132622	25	#Max	16QAM	22.18	21.64
10	132622	50	#0	16QAM	22.23	21.69
15	132047	1	#0	QPSK	24.61	24.07
15	132047	1	#Mid	QPSK	24.91	24.37
15	132047	1	#Max	QPSK	24.87	24.33
15	132047	36	#0	QPSK	23.74	23.20
15	132047	36	#Mid	QPSK	23.73	23.19
15	132047	36	#Max	QPSK	23.97	23.43
15	132047	75	#0	QPSK	23.84	23.30
15	132047	1	#0	16QAM	23.64	23.10
15	132047	1	#Mid	16QAM	23.93	23.39
15	132047	1	#Max	16QAM	23.85	23.31
15	132047	36	#0	16QAM	22.64	22.10
15	132047	36	#Mid	16QAM	22.69	22.15
15	132047	36	#Max	16QAM	22.91	22.37
15	132047	75	#0	16QAM	22.75	22.21
15	132322	1	#0	QPSK	24.43	23.89
15	132322	1	#Mid	QPSK	24.50	23.96
15	132322	1	#Max	QPSK	24.57	24.03
15	132322	36	#0	QPSK	23.50	22.96
15	132322	36	#Mid	QPSK	23.51	22.97
15	132322	36	#Max	QPSK	23.60	23.06
15	132322	75	#0	QPSK	23.52	22.98
15	132322	1	#0	16QAM	23.50	22.96
15	132322	1	#Mid	16QAM	23.57	23.03
15	132322	1	#Max	16QAM	23.58	23.04
15	132322	36	#0	16QAM	22.47	21.93
15	132322	36	#Mid	16QAM	22.46	21.92
15	132322	36	#Max	16QAM	22.54	22.00
15	132322	75	#0	16QAM	22.51	21.97
15	132597	1	#0	QPSK	24.57	24.03
15	132597	1	#Mid	QPSK	24.54	24.00
15	132597	1	#Max	QPSK	24.51	23.97
15	132597	36	#0	QPSK	23.47	22.93
15	132597	36	#Mid	QPSK	23.47	22.93
15	132597	36	#Max	QPSK	23.38	22.84

15	132597	75	#0	QPSK	23.36	22.82
15	132597	1	#0	16QAM	23.27	22.73
15	132597	1	#Mid	16QAM	23.25	22.71
15	132597	1	#Max	16QAM	23.18	22.64
15	132597	36	#0	16QAM	22.36	21.82
15	132597	36	#Mid	16QAM	22.35	21.81
15	132597	36	#Max	16QAM	22.28	21.74
15	132597	75	#0	16QAM	22.30	21.76
20	132072	1	#0	QPSK	24.63	24.09
20	132072	1	#Mid	QPSK	25.01	24.47
20	132072	1	#Max	QPSK	24.77	24.23
20	132072	50	#0	QPSK	23.55	23.01
20	132072	50	#Mid	QPSK	23.54	23.00
20	132072	50	#Max	QPSK	23.71	23.17
20	132072	100	#0	QPSK	23.59	23.05
20	132072	1	#0	16QAM	23.20	22.66
20	132072	1	#Mid	16QAM	23.60	23.06
20	132072	1	#Max	16QAM	23.33	22.79
20	132072	50	#0	16QAM	22.50	21.96
20	132072	50	#Mid	16QAM	22.56	22.02
20	132072	50	#Max	16QAM	22.72	22.18
20	132072	100	#0	16QAM	22.61	22.07
20	132322	1	#0	QPSK	24.44	23.90
20	132322	1	#Mid	QPSK	24.59	24.05
20	132322	1	#Max	QPSK	24.58	24.04
20	132322	50	#0	QPSK	23.34	22.80
20	132322	50	#Mid	QPSK	23.34	22.80
20	132322	50	#Max	QPSK	23.49	22.95
20	132322	100	#0	QPSK	23.41	22.87
20	132322	1	#0	16QAM	23.51	22.97
20	132322	1	#Mid	16QAM	23.61	23.07
20	132322	1	#Max	16QAM	23.50	22.96
20	132322	50	#0	16QAM	22.36	21.82
20	132322	50	#Mid	16QAM	22.39	21.85
20	132322	50	#Max	16QAM	22.53	21.99
20	132322	100	#0	16QAM	22.48	21.94
20	132572	1	#0	QPSK	24.58	24.04
20	132572	1	#Mid	QPSK	24.54	24.00
20	132572	1	#Max	QPSK	24.38	23.84
20	132572	50	#0	QPSK	23.31	22.77
20	132572	50	#Mid	QPSK	23.33	22.79
20	132572	50	#Max	QPSK	23.15	22.61
20	132572	100	#0	QPSK	23.17	22.63

20	132572	1	#0	16QAM	23.22	22.68
20	132572	1	#Mid	16QAM	23.21	22.67
20	132572	1	#Max	16QAM	22.99	22.45
20	132572	50	#0	16QAM	22.31	21.77
20	132572	50	#Mid	16QAM	22.27	21.73
20	132572	50	#Max	16QAM	22.14	21.60
20	132572	100	#0	16QAM	22.23	21.69
1.4	131979	1	#0	64QAM	22.87	22.33
1.4	131979	1	#Mid	64QAM	22.99	22.45
1.4	131979	1	#Max	64QAM	23.01	22.47
1.4	131979	3	#0	64QAM	23.01	22.47
1.4	131979	3	#Mid	64QAM	23.00	22.46
1.4	131979	3	#Max	64QAM	23.04	22.50
1.4	131979	6	#0	64QAM	22.16	21.62
1.4	132322	1	#0	64QAM	22.92	22.38
1.4	132322	1	#Mid	64QAM	22.95	22.41
1.4	132322	1	#Max	64QAM	22.93	22.39
1.4	132322	3	#0	64QAM	22.77	22.23
1.4	132322	3	#Mid	64QAM	22.78	22.24
1.4	132322	3	#Max	64QAM	22.80	22.26
1.4	132322	6	#0	64QAM	21.98	21.44
1.4	132665	1	#0	64QAM	22.55	22.01
1.4	132665	1	#Mid	64QAM	22.61	22.07
1.4	132665	1	#Max	64QAM	22.57	22.03
1.4	132665	3	#0	64QAM	22.61	22.07
1.4	132665	3	#Mid	64QAM	22.57	22.03
1.4	132665	3	#Max	64QAM	22.56	22.02
1.4	132665	6	#0	64QAM	21.86	21.32
3	131987	1	#0	64QAM	22.96	22.42
3	131987	1	#Mid	64QAM	23.09	22.55
3	131987	1	#Max	64QAM	23.04	22.50
3	131987	8	#0	64QAM	22.02	21.48
3	131987	8	#Mid	64QAM	22.05	21.51
3	131987	8	#Max	64QAM	22.11	21.57
3	131987	15	#0	64QAM	22.00	21.46
3	132322	1	#0	64QAM	22.55	22.01
3	132322	1	#Mid	64QAM	22.66	22.12
3	132322	1	#Max	64QAM	22.61	22.07
3	132322	8	#0	64QAM	21.85	21.31
3	132322	8	#Mid	64QAM	21.88	21.34
3	132322	8	#Max	64QAM	21.92	21.38
3	132322	15	#0	64QAM	21.94	21.40
3	132657	1	#0	64QAM	22.70	22.16

3	132657	1	#Mid	64QAM	22.82	22.28
3	132657	1	#Max	64QAM	22.72	22.18
3	132657	8	#0	64QAM	21.77	21.23
3	132657	8	#Mid	64QAM	21.78	21.24
3	132657	8	#Max	64QAM	21.78	21.24
3	132657	15	#0	64QAM	21.76	21.22
5	131997	1	#0	64QAM	24.15	23.61
5	131997	1	#Mid	64QAM	24.40	23.86
5	131997	1	#Max	64QAM	24.30	23.76
5	131997	12	#0	64QAM	23.11	22.57
5	131997	12	#Mid	64QAM	23.09	22.55
5	131997	12	#Max	64QAM	23.22	22.68
5	131997	25	#0	64QAM	23.08	22.54
5	132322	1	#0	64QAM	24.02	23.48
5	132322	1	#Mid	64QAM	24.12	23.58
5	132322	1	#Max	64QAM	24.10	23.56
5	132322	12	#0	64QAM	22.92	22.38
5	132322	12	#Mid	64QAM	22.91	22.37
5	132322	12	#Max	64QAM	23.01	22.47
5	132322	25	#0	64QAM	22.94	22.40
5	132647	1	#0	64QAM	23.81	23.27
5	132647	1	#Mid	64QAM	23.99	23.45
5	132647	1	#Max	64QAM	23.84	23.30
5	132647	12	#0	64QAM	22.85	22.31
5	132647	12	#Mid	64QAM	22.83	22.29
5	132647	12	#Max	64QAM	22.81	22.27
5	132647	25	#0	64QAM	22.81	22.27
10	132022	1	#0	64QAM	23.24	22.70
10	132022	1	#Mid	64QAM	23.37	22.83
10	132022	1	#Max	64QAM	23.47	22.93
10	132022	25	#0	64QAM	22.07	21.53
10	132022	25	#Mid	64QAM	22.08	21.54
10	132022	25	#Max	64QAM	22.31	21.77
10	132022	50	#0	64QAM	22.17	21.63
10	132322	1	#0	64QAM	22.87	22.33
10	132322	1	#Mid	64QAM	22.90	22.36
10	132322	1	#Max	64QAM	22.94	22.40
10	132322	25	#0	64QAM	21.96	21.42
10	132322	25	#Mid	64QAM	21.94	21.40
10	132322	25	#Max	64QAM	22.05	21.51
10	132322	50	#0	64QAM	21.99	21.45
10	132622	1	#0	64QAM	23.01	22.47
10	132622	1	#Mid	64QAM	22.97	22.43

10	132622	1	#Max	64QAM	22.97	22.43
10	132622	25	#0	64QAM	21.89	21.35
10	132622	25	#Mid	64QAM	21.89	21.35
10	132622	25	#Max	64QAM	21.83	21.29
10	132622	50	#0	64QAM	21.81	21.27
15	132047	1	#0	64QAM	23.17	22.63
15	132047	1	#Mid	64QAM	23.48	22.94
15	132047	1	#Max	64QAM	23.40	22.86
15	132047	36	#0	64QAM	22.23	21.69
15	132047	36	#Mid	64QAM	22.20	21.66
15	132047	36	#Max	64QAM	22.39	21.85
15	132047	75	#0	64QAM	22.33	21.79
15	132322	1	#0	64QAM	22.96	22.42
15	132322	1	#Mid	64QAM	23.06	22.52
15	132322	1	#Max	64QAM	23.05	22.51
15	132322	36	#0	64QAM	21.99	21.45
15	132322	36	#Mid	64QAM	22.00	21.46
15	132322	36	#Max	64QAM	22.09	21.55
15	132322	75	#0	64QAM	22.12	21.58
15	132597	1	#0	64QAM	23.03	22.49
15	132597	1	#Mid	64QAM	23.00	22.46
15	132597	1	#Max	64QAM	22.90	22.36
15	132597	36	#0	64QAM	21.93	21.39
15	132597	36	#Mid	64QAM	21.97	21.43
15	132597	36	#Max	64QAM	21.88	21.34
15	132597	75	#0	64QAM	21.91	21.37
20	132072	1	#0	64QAM	22.90	22.36
20	132072	1	#Mid	64QAM	23.32	22.78
20	132072	1	#Max	64QAM	23.06	22.52
20	132072	50	#0	64QAM	22.06	21.52
20	132072	50	#Mid	64QAM	22.08	21.54
20	132072	50	#Max	64QAM	22.22	21.68
20	132072	100	#0	64QAM	22.19	21.65
20	132322	1	#0	64QAM	22.66	22.12
20	132322	1	#Mid	64QAM	22.80	22.26
20	132322	1	#Max	64QAM	22.72	22.18
20	132322	50	#0	64QAM	22.01	21.47
20	132322	50	#Mid	64QAM	22.00	21.46
20	132322	50	#Max	64QAM	22.09	21.55
20	132322	100	#0	64QAM	22.04	21.50
20	132572	1	#0	64QAM	23.05	22.51
20	132572	1	#Mid	64QAM	23.00	22.46
20	132572	1	#Max	64QAM	22.82	22.28

20	132572	50	#0	64QAM	21.90	21.36
20	132572	50	#Mid	64QAM	21.89	21.35
20	132572	50	#Max	64QAM	21.74	21.20
20	132572	100	#0	64QAM	21.80	21.26

6.2 Occupied Bandwidth

Mode	Channel	Frequency (MHz)	99% Power Bandwidth (MHz)	-26dBc Bandwidth(MHz)
WCDMA Band IV (RMC)	1312	1712.4	4.19	4.74
	1413	1732.6	4.17	4.70
	1513	1752.6	4.17	4.70

LTE Band 4						
RB	Modulation	Bandwidth (MHz)	Channel	Frequency (MHz)	99% Power Bandwidth(MHz)	-26dBc Bandwidth(MHz)
100%	QPSK	1.4	19957	1710.7	1.10	1.30
			20175	1732.5	1.10	1.26
			20393	1754.3	1.10	1.30
		3	19965	1711.5	2.69	2.97
			20175	1732.5	2.68	3.00
			20385	1753.5	2.69	2.96
		5	19975	1712.5	4.52	4.95
			20175	1732.5	4.51	4.91
			20375	1752.5	4.51	4.89
		10	20000	1715	9.00	9.77
			20175	1732.5	8.97	9.72
			20350	1750	8.98	9.68
		15	20025	1717.5	13.47	14.38
			20175	1732.5	13.45	14.55
			20325	1747.5	13.47	14.54
		20	20050	1720	17.94	19.32
			20175	1732.5	17.92	19.14
			20300	1745	17.95	19.18
	16QAM	1.4	19957	1710.7	1.10	1.26
			20175	1732.5	1.10	1.28
			20393	1754.3	1.11	1.28
		3	19965	1711.5	2.70	2.94
			20175	1732.5	2.68	2.96
			20385	1753.5	2.69	2.98
		5	19975	1712.5	4.52	4.90
			20175	1732.5	4.50	4.88
			20375	1752.5	4.51	4.88
		10	20000	1715	8.98	9.61
			20175	1732.5	8.97	9.62
			20350	1750	8.97	9.65
15	20025	1717.5	13.50	14.55		

		20	20175	1732.5	13.48	14.39	
			20325	1747.5	13.47	14.51	
			20050	1720	17.92	19.29	
			20175	1732.5	17.98	19.19	
			20300	1745	17.96	19.21	
	64QAM	1.4		19957	1710.7	1.10	1.27
				20175	1732.5	1.09	1.28
				20393	1754.3	1.10	1.27
		3		19965	1711.5	2.69	2.99
				20175	1732.5	2.69	2.96
				20385	1753.5	2.69	3.00
		5		19975	1712.5	4.52	4.93
				20175	1732.5	4.50	4.91
				20375	1752.5	4.51	4.83
		10		20000	1715	8.99	9.71
				20175	1732.5	8.99	9.61
				20350	1750	8.97	9.71
		15		20025	1717.5	13.48	14.59
				20175	1732.5	13.49	14.52
				20325	1747.5	13.51	14.41
20		20050	1720	17.93	19.42		
		20175	1732.5	17.95	19.35		
		20300	1745	17.95	19.32		

LTE Band 7							
RB	Modulation	Bandwidth (MHz)	Channel	Frequency (MHz)	99% Power Bandwidth(MHz)	-26dBc Bandwidth(MHz)	
100%	QPSK	5	20775	2502.5	4.51	4.90	
			21100	2535	4.51	4.87	
			21425	2567.5	4.52	4.91	
		10		20800	2505	8.98	9.62
				21100	2535	8.98	9.69
				21400	2565	8.98	9.80
		15		20825	2507.5	13.47	14.58
				21100	2535	13.48	14.54
				21375	2562.5	13.43	14.51
	20		20850	2510	17.95	19.39	
			21100	2535	17.97	19.14	
			21350	2560	17.94	19.32	
	16QAM	5		20775	2502.5	4.51	4.92
				21100	2535	4.51	4.89
				21425	2567.5	4.51	4.88
10		20800	2505	8.98	9.70		

			21100	2535	8.99	9.65	
			21400	2565	9.02	9.74	
		15	20825	2507.5	13.46	14.43	
			21100	2535	13.50	14.54	
			21375	2562.5	13.52	14.47	
		20	20850	2510	17.90	19.31	
			21100	2535	18.02	19.46	
			21350	2560	17.96	19.23	
		64QAM	5	20775	2502.5	4.51	4.90
				21100	2535	4.51	4.90
	21425			2567.5	4.51	4.91	
	10		20800	2505	8.98	9.64	
			21100	2535	9.00	9.71	
			21400	2565	8.98	9.67	
	15		20825	2507.5	13.49	14.51	
			21100	2535	13.45	14.57	
			21375	2562.5	13.48	14.50	
	20		20850	2510	17.94	19.17	
		21100	2535	17.99	19.26		
		21350	2560	17.96	19.16		

LTE Band 12						
RB	Modulation	Bandwidth (MHz)	Channel	Frequency (MHz)	99% Power Bandwidth(MHz)	-26dBc Bandwidth(MHz)
100%	QPSK	1.4	23017	699.7	1.09	1.27
			23095	707.5	1.10	1.28
			23173	715.3	1.10	1.28
		3	23025	700.5	2.69	2.98
			23095	707.5	2.69	2.99
			23165	714.5	2.69	2.98
		5	23035	701.5	4.51	4.88
			23095	707.5	4.51	4.91
			23155	713.5	4.51	4.90
	10	23060	704	8.94	9.62	
		23095	707.5	8.98	9.74	
		23130	711	9.00	9.71	
	16QAM	1.4	23017	699.7	1.09	1.26
			23095	707.5	1.09	1.28
			23173	715.3	1.10	1.29
		3	23025	700.5	2.69	2.99
			23095	707.5	2.69	2.96
			23165	714.5	2.68	3.02
5		23035	701.5	4.51	4.90	

		10	23095	707.5	4.51	4.89	
			23155	713.5	4.51	4.91	
			23060	704	8.94	9.61	
			23095	707.5	8.95	9.69	
			23130	711	8.97	9.69	
	64QAM	1.4		23017	699.7	1.10	1.26
				23095	707.5	1.10	1.27
				23173	715.3	1.10	1.28
		3		23025	700.5	2.69	3.00
				23095	707.5	2.69	2.95
				23165	714.5	2.68	3.02
		5		23035	701.5	4.52	4.90
				23095	707.5	4.52	4.90
				23155	713.5	4.51	4.91
		10		23060	704	8.92	9.66
				23095	707.5	8.98	9.65
				23130	711	8.99	9.66

LTE Band 13						
RB	Modulation	Bandwidth (MHz)	Channel	Frequency (MHz)	99% Power Bandwidth(MHz)	-26dBc Bandwidth(MHz)
100%	QPSK	5	23205	779.5	4.50	4.91
			23230	782	4.50	4.91
			23255	784.5	4.50	4.90
		10	23230	782	8.96	9.62
	16QAM	5	23205	779.5	4.50	4.89
			23230	782	4.52	4.88
			23255	784.5	4.50	4.87
		10	23230	782	8.94	9.62
	64QAM	5	23205	779.5	4.50	4.86
			23230	782	4.51	4.91
			23255	784.5	4.51	4.88
		10	23230	782	8.95	9.67

LTE Band 17						
RB	Modulation	Bandwidth (MHz)	Channel	Frequency (MHz)	99% Power Bandwidth(MHz)	-26dBc Bandwidth(MHz)
100%	QPSK	5	23755	706.5	4.52	4.89
			23790	710	4.50	4.90
			23825	713.5	4.51	4.89
		10	23780	709	8.97	9.67
			23790	710	8.99	9.66
			23800	711	9.00	9.75
	16QAM	5	23755	706.5	4.50	4.93
			23790	710	4.51	4.95
			23825	713.5	4.51	4.88
		10	23780	709	8.97	9.72
			23790	710	8.98	9.65
			23800	711	9.01	9.65
	64QAM	5	23755	706.5	4.49	4.94
			23790	710	4.50	4.90
			23825	713.5	4.50	4.91
		10	23780	709	8.93	9.66
			23790	710	9.00	9.68
			23800	711	8.97	9.68

LTE Band 38						
RB	Modulation	Bandwidth (MHz)	Channel	Frequency (MHz)	99% Power Bandwidth(MHz)	-26dBc Bandwidth(MHz)
100%	QPSK	5	37775	2572.5	4.52	4.85
			38000	2595	4.51	4.85
			38225	2617.5	4.52	4.90
		10	37800	2575	8.99	9.63
			38000	2595	8.99	9.84
			38200	2615	8.98	9.76
		15	37825	2577.5	13.46	14.52
			38000	2595	13.46	14.39
			38175	2612.5	13.42	14.43
		20	37850	2580	17.94	19.14
			38000	2595	17.93	19.28
			38150	2610	17.90	19.02
	16QAM	5	37775	2572.5	4.51	4.92
			38000	2595	4.51	4.91
			38225	2617.5	4.51	4.86
		10	37800	2575	8.99	9.70
			38000	2595	8.99	9.61

		15	38200	2615	8.97	9.88	
			37825	2577.5	13.43	14.66	
			38000	2595	13.45	14.43	
		20	38175	2612.5	13.46	14.30	
			37850	2580	17.97	19.31	
			38000	2595	17.91	19.34	
		64QAM	5	38150	2610	17.93	19.35
				37775	2572.5	4.53	4.87
				38000	2595	4.51	4.85
			10	38225	2617.5	4.52	4.90
				37800	2575	8.99	9.54
				38000	2595	8.99	9.89
	15		38200	2615	9.00	9.76	
			37825	2577.5	13.47	14.82	
			38000	2595	13.46	14.41	
	20		38175	2612.5	13.47	14.32	
			37850	2580	17.91	19.01	
			38000	2595	17.89	19.14	
				38150	2610	17.94	19.12

LTE Band 41						
RB	Modulation	Bandwidth (MHz)	Channel	Frequency (MHz)	99% Power Bandwidth(MHz)	-26dBc Bandwidth(MHz)
100%	QPSK	5	39675	2498.5	4.52	4.82
			40620	2593	4.51	4.89
			41565	2687.5	4.53	4.91
		10	39700	2501	8.99	9.66
			40620	2593	8.98	9.67
			41540	2685	9.00	9.75
		15	39725	2503.5	13.49	14.44
			40620	2593	13.44	14.69
			41515	2682.5	13.48	15.37
		20	39750	2506	17.94	19.13
			40620	2593	17.89	19.16
			41490	2680	17.99	19.87
	16QAM	5	39675	2498.5	4.52	4.95
			40620	2593	4.51	4.91
			41565	2687.5	4.51	4.92
		10	39700	2501	9.00	9.81
			40620	2593	8.98	9.64
			41540	2685	8.99	9.67
		15	39725	2503.5	13.47	14.55
			40620	2593	13.46	14.44

		20	41515	2682.5	13.47	14.39	
			39750	2506	18.00	19.46	
			40620	2593	17.97	19.48	
			41490	2680	17.92	19.08	
	64QAM	5		39675	2498.5	4.51	4.89
				40620	2593	4.51	4.88
				41565	2687.5	4.51	4.93
		10		39700	2501	9.00	9.82
				40620	2593	8.98	9.72
				41540	2685	8.98	9.62
		15		39725	2503.5	13.50	14.56
				40620	2593	13.46	14.49
				41515	2682.5	13.47	15.53
		20		39750	2506	17.95	21.92
				40620	2593	17.96	19.17
				41490	2680	17.98	19.13

LTE Band 66							
RB	Modulation	Bandwidth (MHz)	Channel	Frequency (MHz)	99% Power Bandwidth(MHz)	-26dBc Bandwidth(MHz)	
100%	QPSK	1.4	131979	1710.7	1.10	1.29	
			132322	1745	1.10	1.26	
			132665	1779.3	1.10	1.27	
		3		131987	1711.5	2.70	2.97
				132322	1745	2.70	2.96
				132657	1778.5	2.70	2.98
		5		131997	1712.5	4.52	4.88
				132322	1745	4.50	4.90
				132647	1777.5	4.51	4.91
		10		132022	1715	8.98	9.62
				132322	1745	8.98	9.72
				132622	1775	8.97	9.61
		15		132047	1717.5	13.48	14.62
				132322	1745	13.50	14.54
				132597	1772.5	13.41	14.57
		20		132072	1720	17.90	19.22
				132322	1745	17.93	19.35
				132572	1770	17.91	19.29
		16QAM	1.4	131979	1710.7	1.09	1.28
				132322	1745	1.10	1.27
				132665	1779.3	1.10	1.31

		3	131987	1711.5	2.69	2.95
			132322	1745	2.69	2.98
			132657	1778.5	2.68	3.01
		5	131997	1712.5	4.51	4.92
			132322	1745	4.51	4.92
			132647	1777.5	4.52	4.88
		10	132022	1715	8.96	9.61
			132322	1745	8.97	9.73
			132622	1775	8.97	9.66
		15	132047	1717.5	13.48	14.49
			132322	1745	13.46	14.43
			132597	1772.5	13.43	14.50
		20	132072	1720	17.95	19.15
			132322	1745	17.95	19.37
			132572	1770	17.97	19.38
	64QAM	1.4	131979	1710.7	1.10	1.26
			132322	1745	1.10	1.29
			132665	1779.3	1.10	1.29
		3	131987	1711.5	2.68	3.02
			132322	1745	2.68	2.95
			132657	1778.5	2.69	2.98
		5	131997	1712.5	4.51	4.92
			132322	1745	4.51	4.89
			132647	1777.5	4.52	4.90
		10	132022	1715	8.96	9.66
			132322	1745	8.98	9.68
			132622	1775	8.97	9.68
		15	132047	1717.5	13.47	14.63
			132322	1745	13.46	14.46
			132597	1772.5	13.45	14.55
20	132072	1720	17.95	19.44		
	132322	1745	17.95	19.40		
	132572	1770	17.94	19.18		

WCDMA Band IV CH-Low



WCDMA Band IV CH Middle



WCDMA Band IV CH High

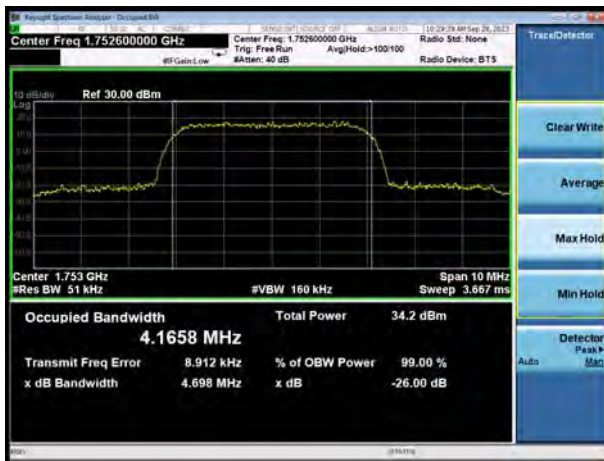

LTE Band 4 QPSK 1.4MHz CH-Low



LTE Band 4 QPSK 3MHz CH-Low



LTE Band 4 QPSK 1.4MHz CH-Middle



LTE Band 4 QPSK 3MHz CH-Middle

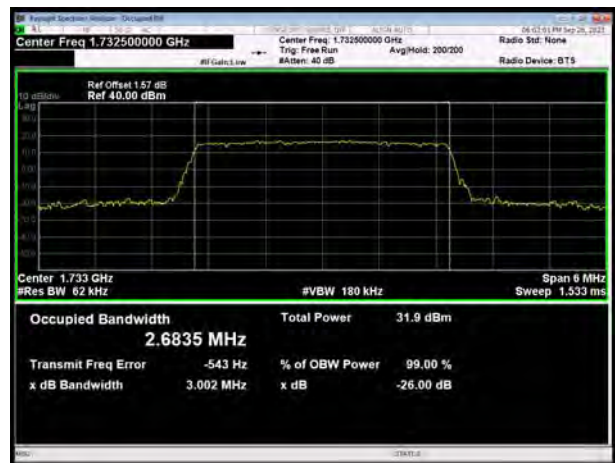

LTE Band 4 QPSK 1.4MHz CH-High

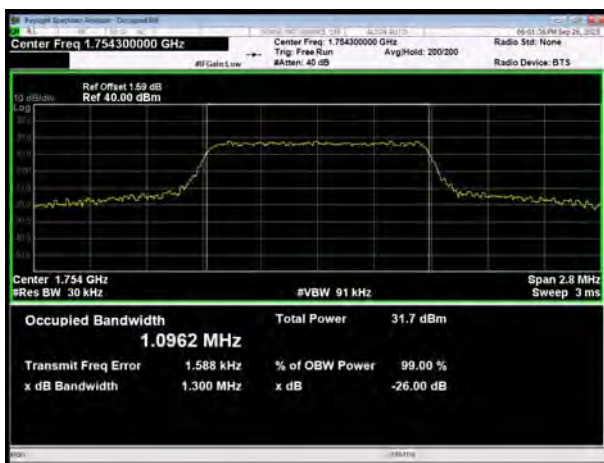

LTE Band 4 QPSK 3MHz CH-High

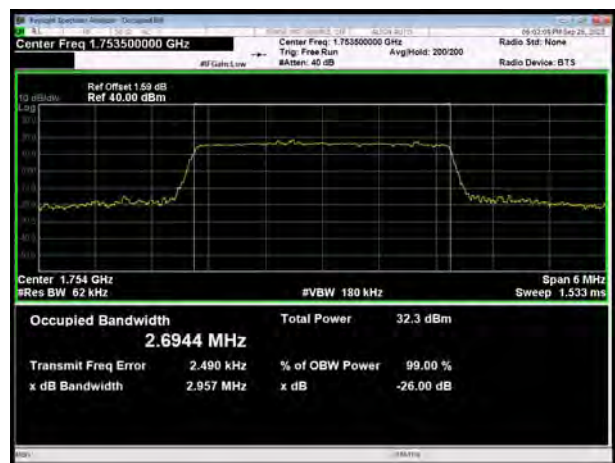

LTE Band 4 QPSK 5MHz CH-Low



LTE Band 4 QPSK 10MHz CH-Low



LTE Band 4 QPSK 5MHz CH-Middle

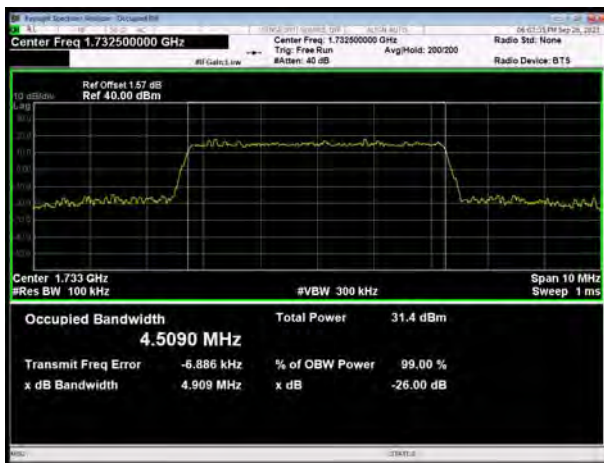

LTE Band 4 QPSK 10MHz CH-Middle



LTE Band 4 QPSK 5MHz CH-High

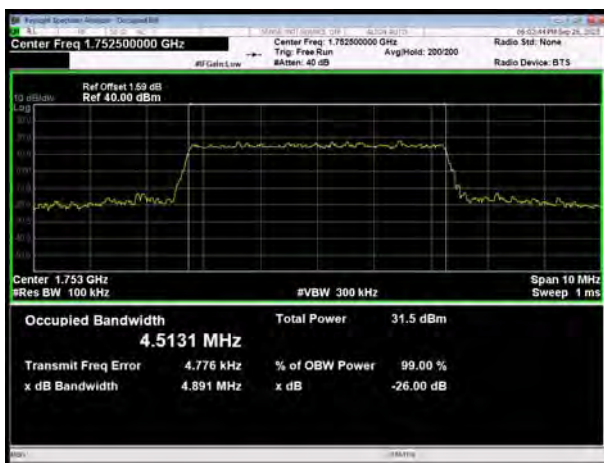

LTE Band 4 QPSK 10MHz CH-High

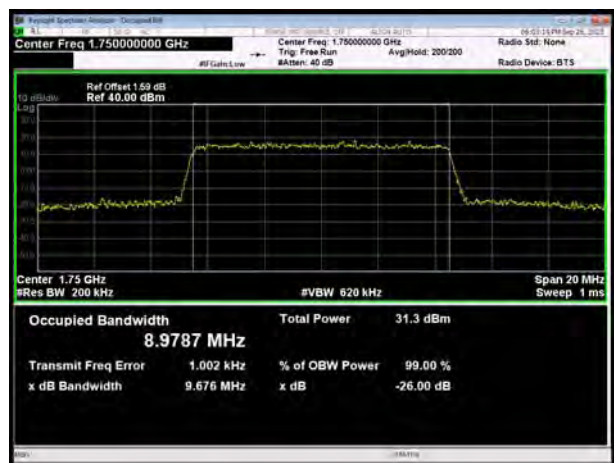

LTE Band 4 QPSK 15MHz CH-Low



LTE Band 4 QPSK 20MHz CH-Low



LTE Band 4 QPSK 15MHz CH-Middle



LTE Band 4 QPSK 20MHz CH-Middle

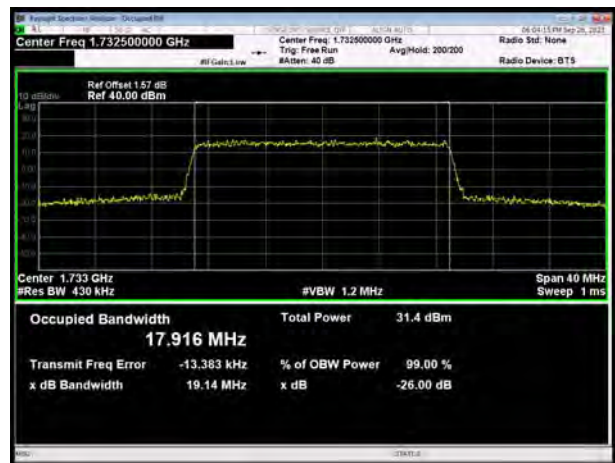

LTE Band 4 QPSK 15MHz CH-High

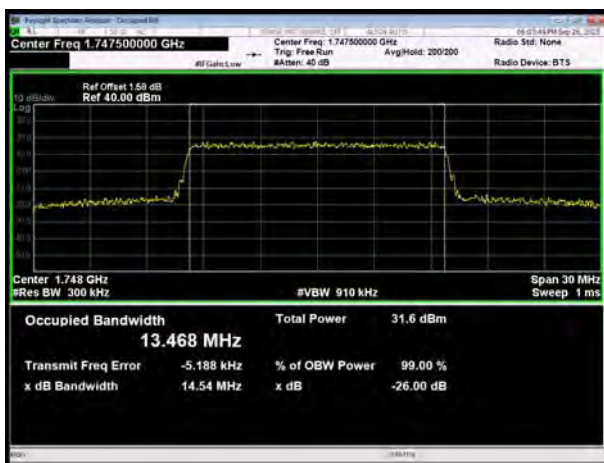

LTE Band 4 QPSK 20MHz CH-High

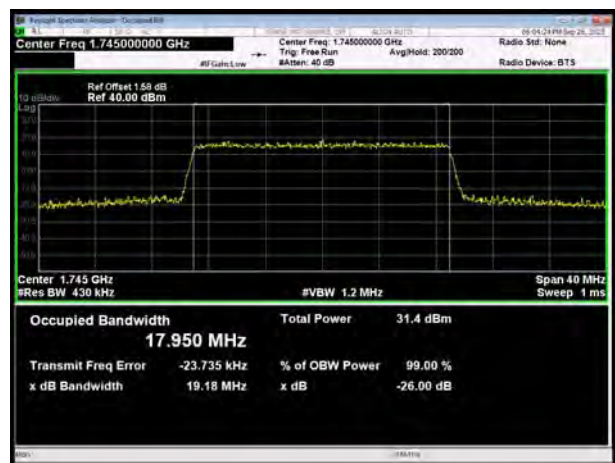

LTE Band 4 16QAM 1.4MHz CH-Low

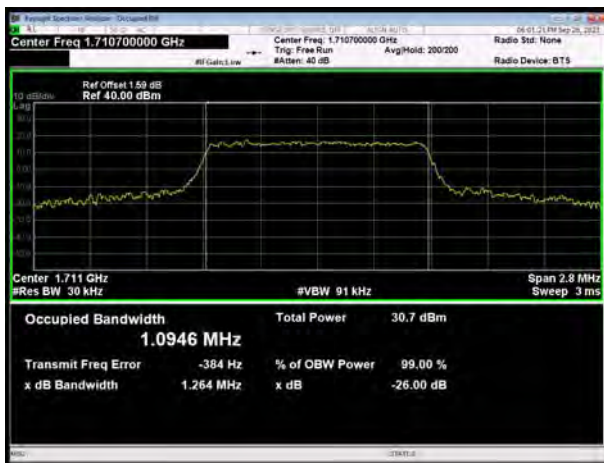

LTE Band 4 16QAM 3MHz CH-Low



LTE Band 4 16QAM 1.4MHz CH-Middle



LTE Band 4 16QAM 3MHz CH-Middle

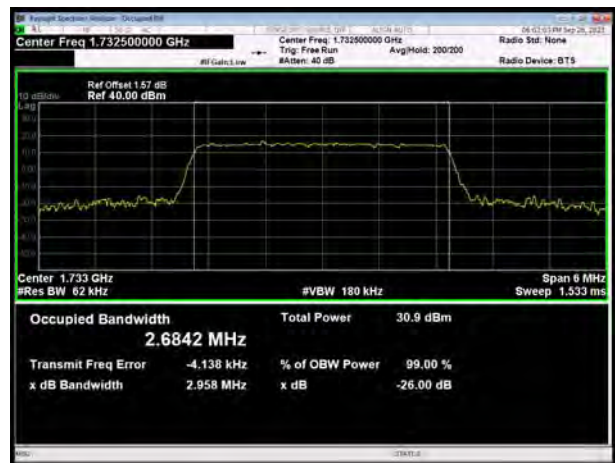

LTE Band 4 16QAM 1.4MHz CH-High

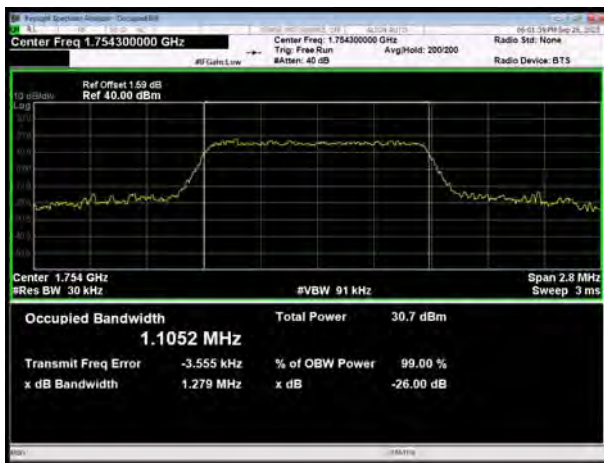

LTE Band 4 16QAM 3MHz CH-High

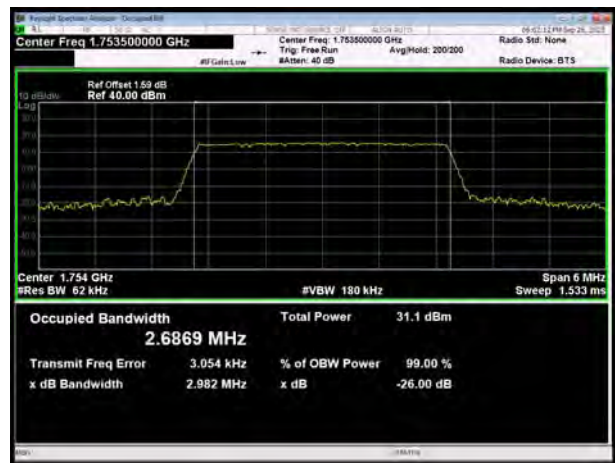

LTE Band 4 16QAM 5MHz CH-Low



LTE Band 4 16QAM 10MHz CH-Low



LTE Band 4 16QAM 5MHz CH-Middle

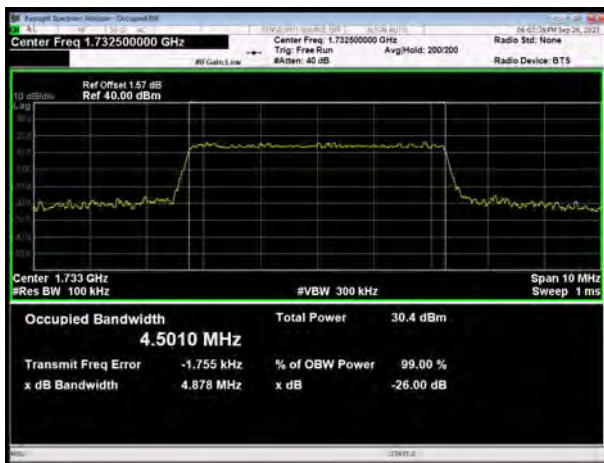

LTE Band 4 16QAM 10MHz CH-Middle

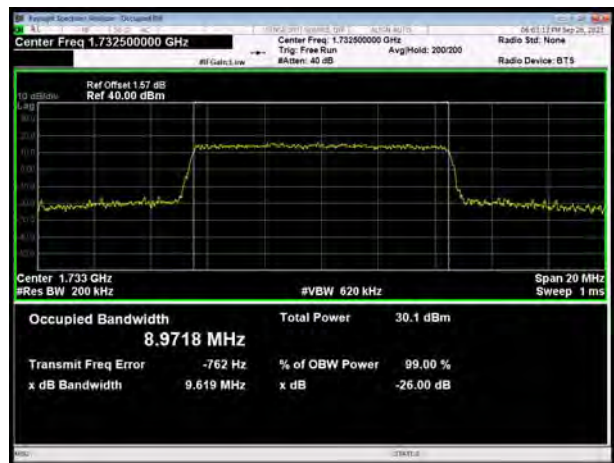

LTE Band 4 16QAM 5MHz CH-High

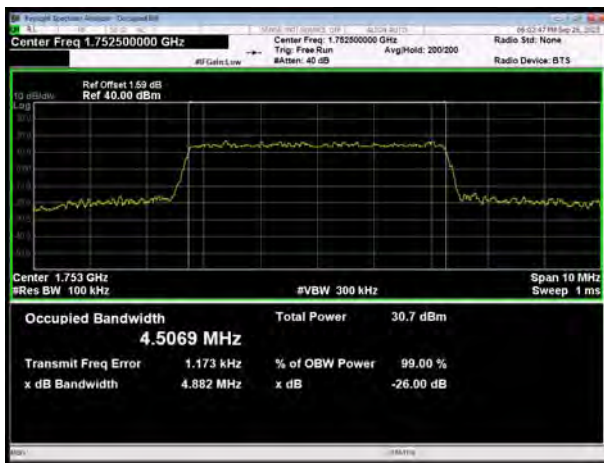

LTE Band 4 16QAM 10MHz CH-High

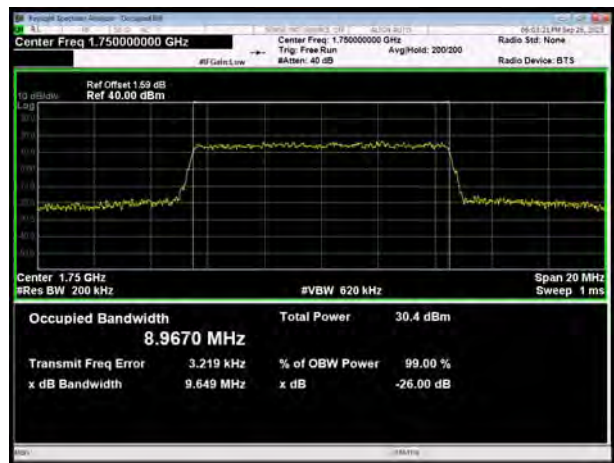

LTE Band 4 16QAM 15MHz CH-Low



LTE Band 4 16QAM 20MHz CH-Low



LTE Band 4 16QAM 15MHz CH-Middle



LTE Band 4 16QAM 20MHz CH-Middle



LTE Band 4 16QAM 15MHz CH-High

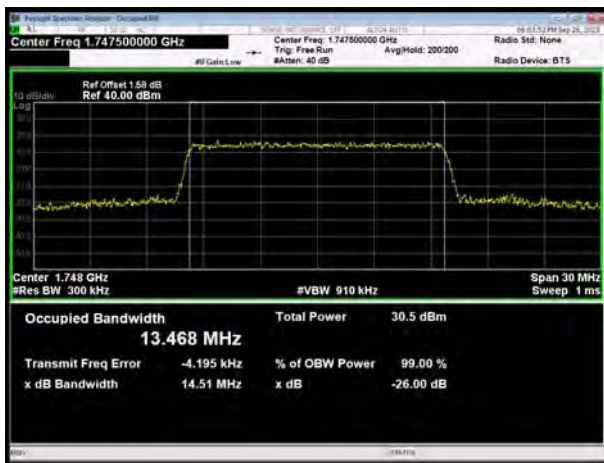

LTE Band 4 16QAM 20MHz CH-High

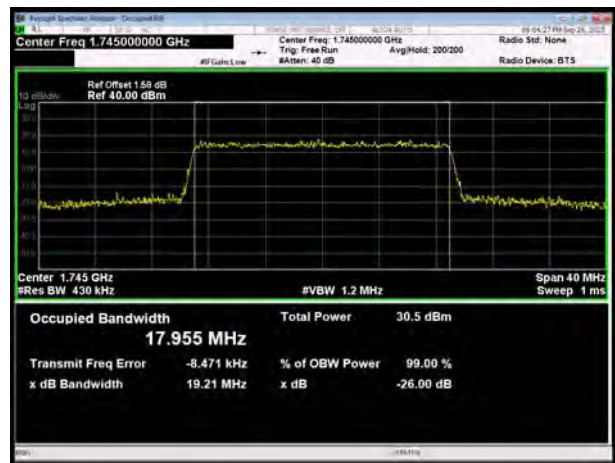

LTE Band 4 1.4MHz 64QAM CH-Low



LTE Band 4 3MHz 64QAM CH-Low



LTE Band 4 1.4MHz 64QAM CH-Middle

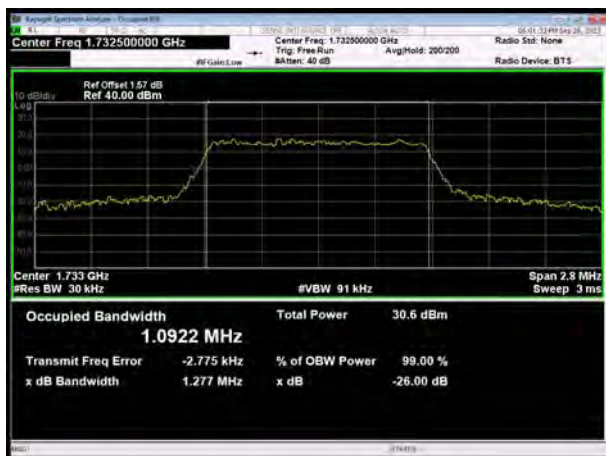

LTE Band 4 3MHz 64QAM CH-Middle

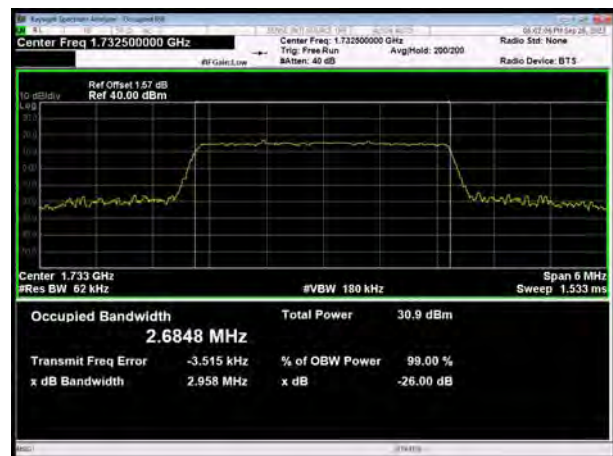

LTE Band 4 1.4MHz 64QAM CH-High

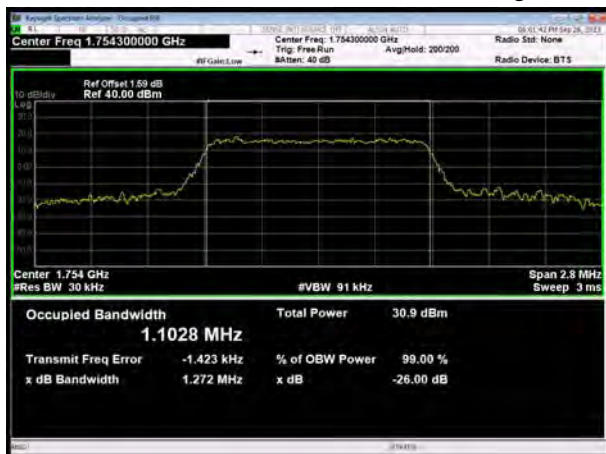

LTE Band 4 3MHz 64QAM CH-High

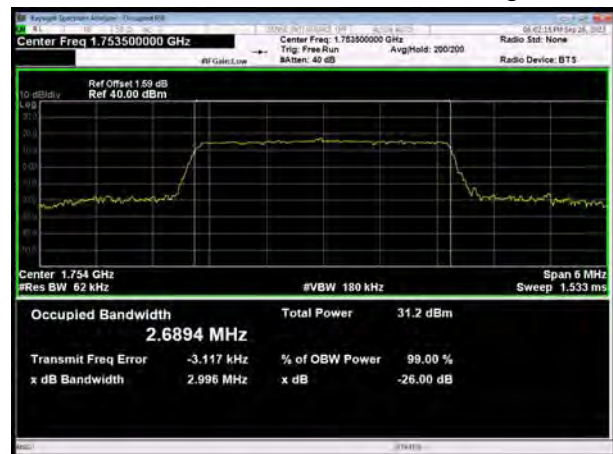

LTE Band 4 5MHz 64QAM CH-Low



LTE Band 4 10MHz 64QAM CH-Low

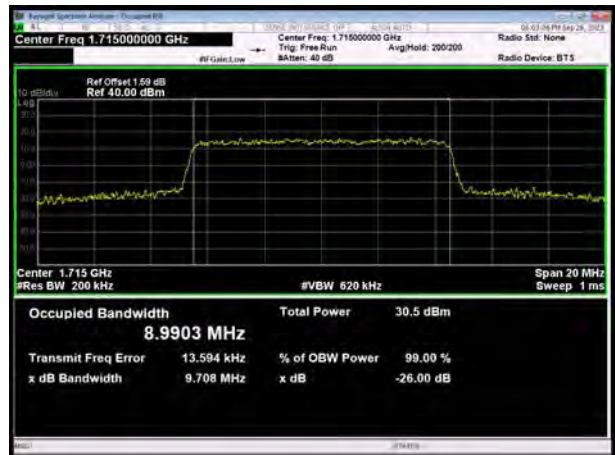

LTE Band 4 5MHz 64QAM CH-Middle

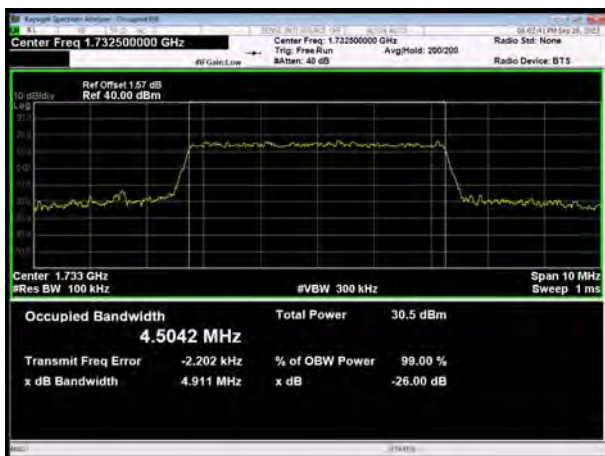

LTE Band 4 10MHz 64QAM CH-Middle



LTE Band 4 5MHz 64QAM CH-High

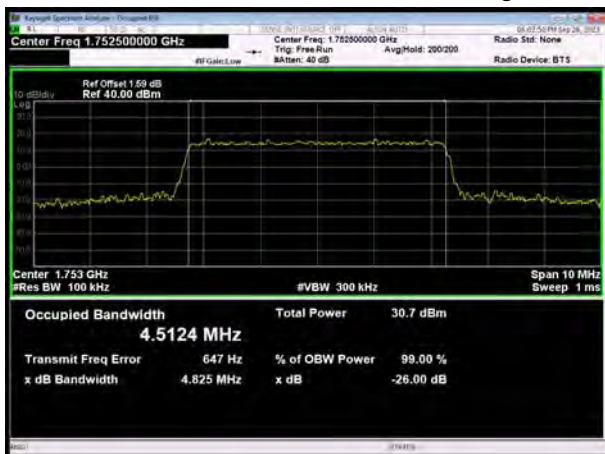

LTE Band 4 10MHz 64QAM CH-High

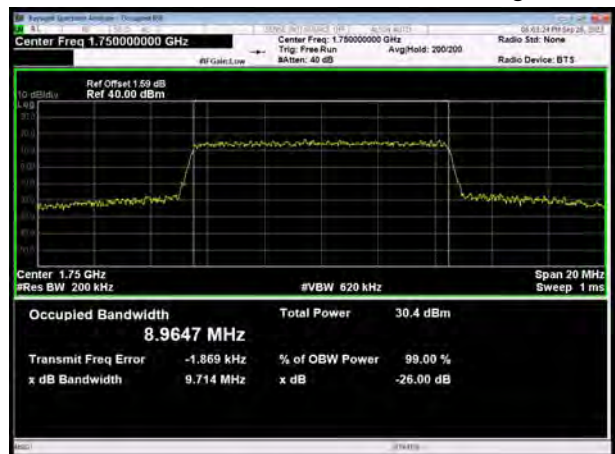

LTE Band 4 15MHz 64QAM CH-Low

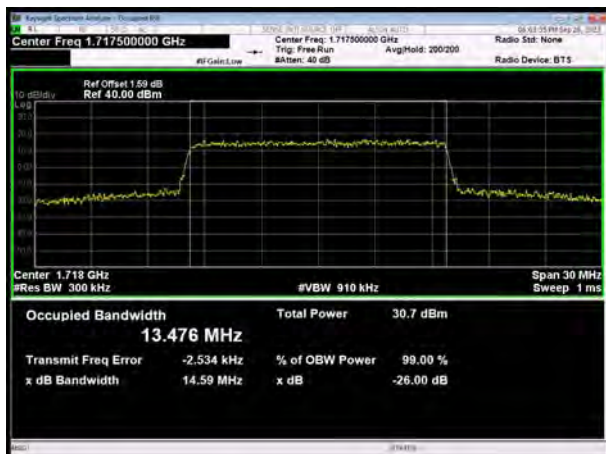

LTE Band 4 20MHz 64QAM CH-Low

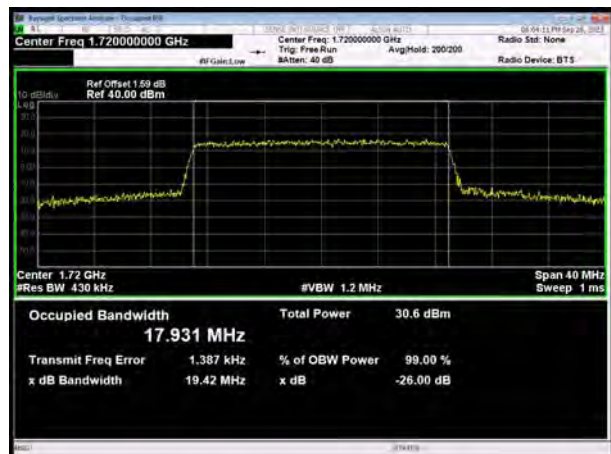

LTE Band 4 15MHz 64QAM CH-Middle

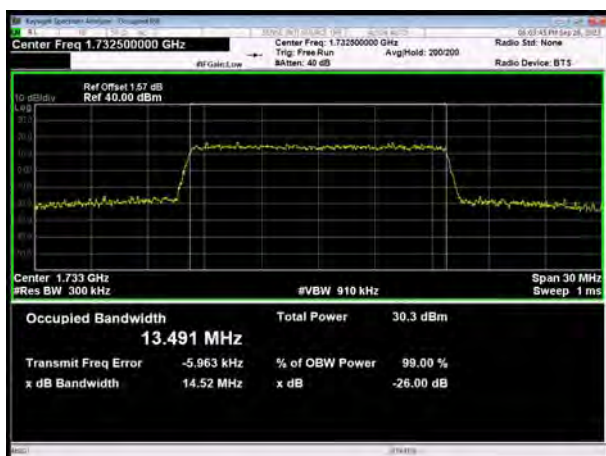

LTE Band 4 20MHz 64QAM CH-Middle

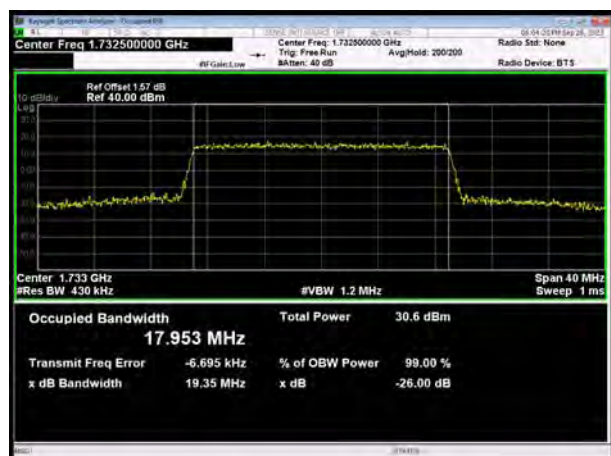

LTE Band 4 15MHz 64QAM CH-High

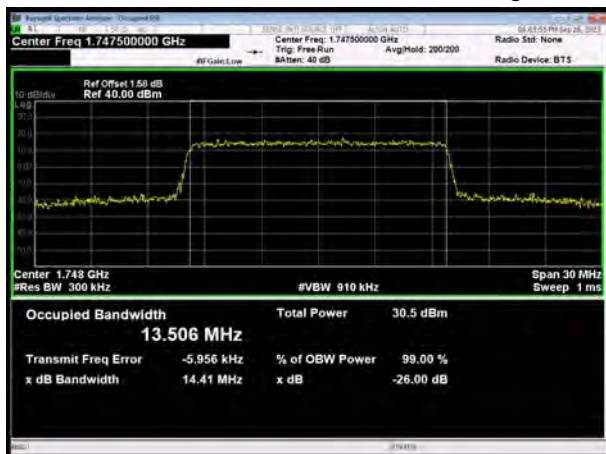

LTE Band 4 20MHz 64QAM CH-High

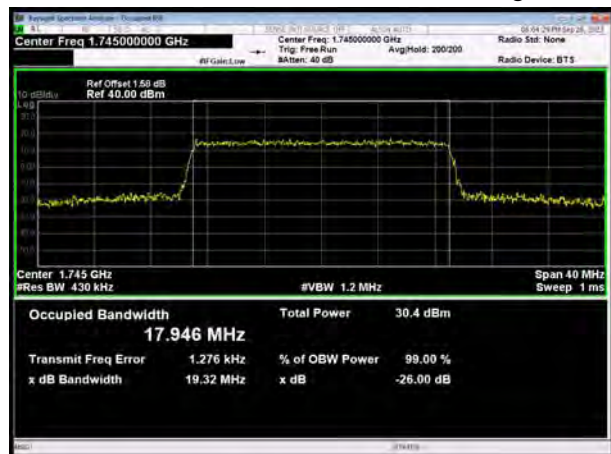

LTE Band 7 QPSK 5MHz CH-Low



LTE Band 7 QPSK 10MHz CH-Low



LTE Band 7 QPSK 5MHz CH-Middle



LTE Band 7 QPSK 10MHz CH-Middle



LTE Band 7 QPSK 5MHz CH-High

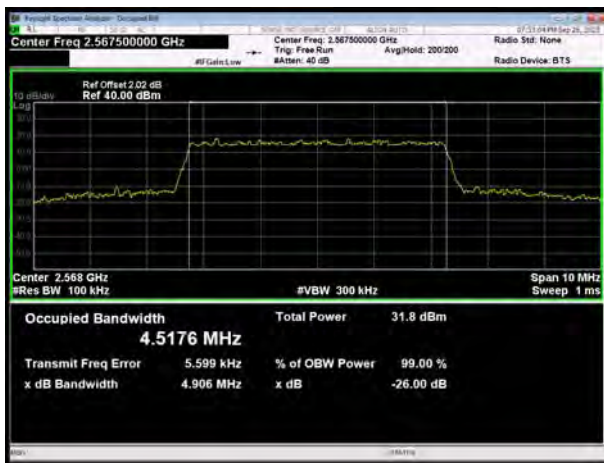

LTE Band 7 QPSK 10MHz CH-High

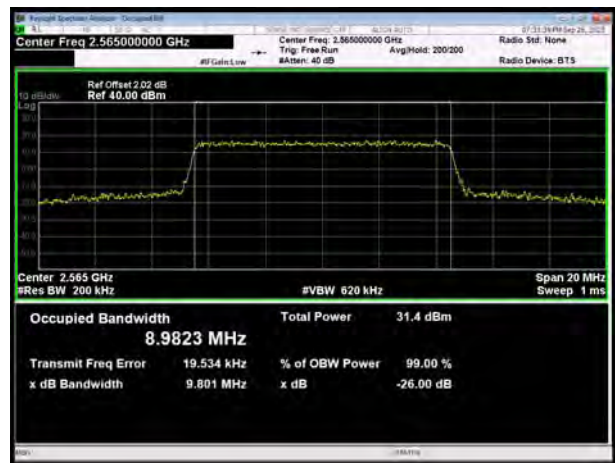

LTE Band 7 QPSK 15MHz CH-Low

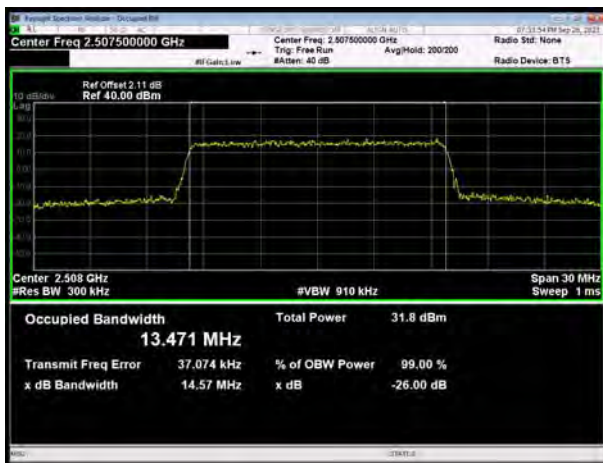

LTE Band 7 QPSK 20MHz CH-Low



LTE Band 7 QPSK 15MHz CH-Middle



LTE Band 7 QPSK 20MHz CH-Middle

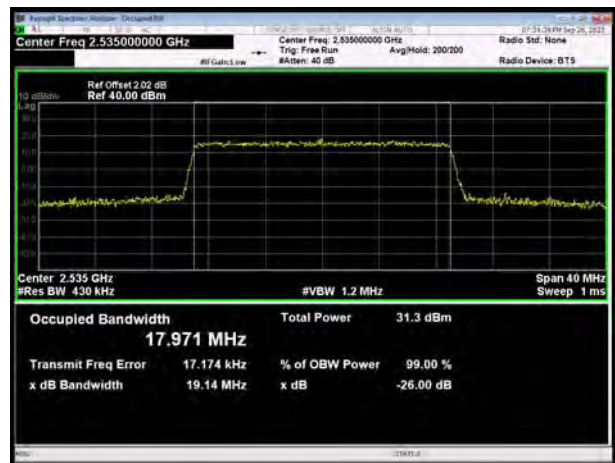

LTE Band 7 QPSK 15MHz CH-High

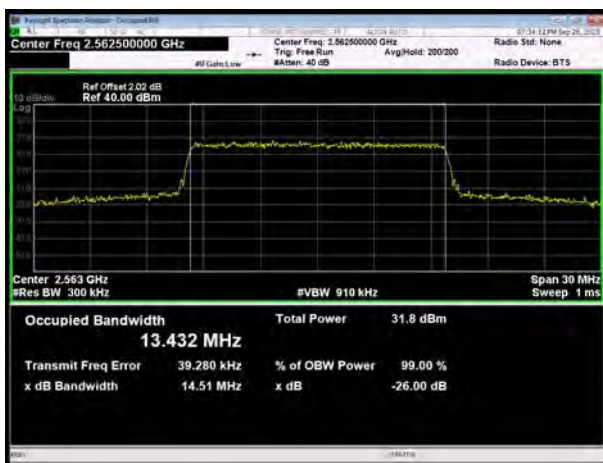

LTE Band 7 QPSK 20MHz CH-High



LTE Band 7 16QAM 5MHz CH-Low



LTE Band 7 16QAM 10MHz CH-Low



LTE Band 7 16QAM 5MHz CH-Middle



LTE Band 7 16QAM 10MHz CH-Middle



LTE Band 7 16QAM 5MHz CH-High

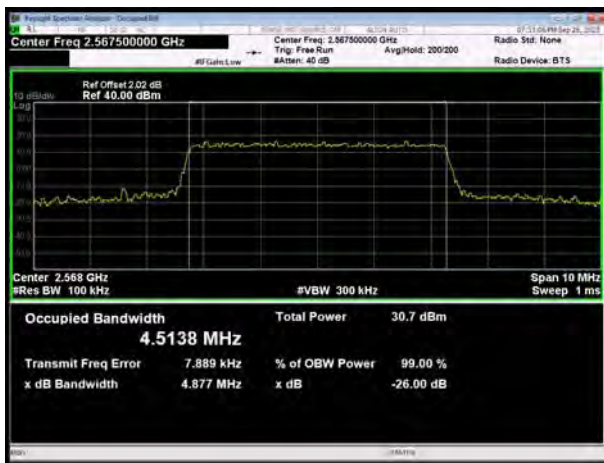

LTE Band 7 16QAM 10MHz CH-High

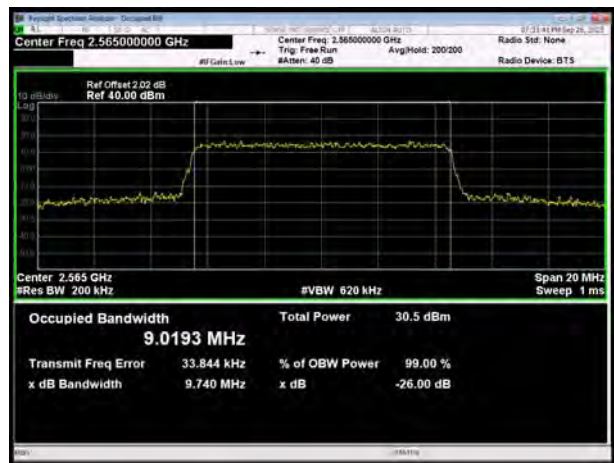

LTE Band 7 16QAM 15MHz CH-Low



LTE Band 7 16QAM 20MHz CH-Low



LTE Band 7 16QAM 15MHz CH-Middle



LTE Band 7 16QAM 20MHz CH-Middle

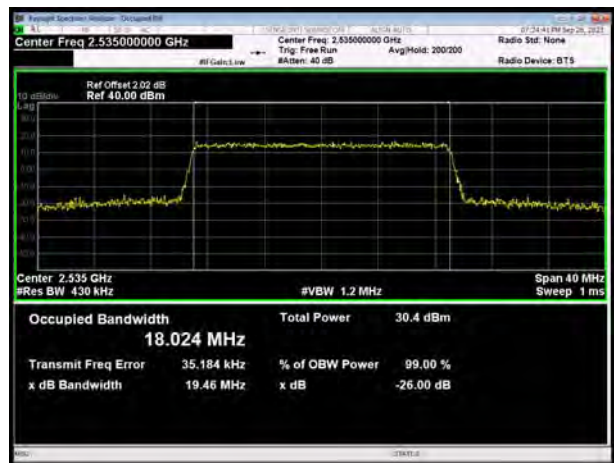

LTE Band 7 16QAM 15MHz CH-High

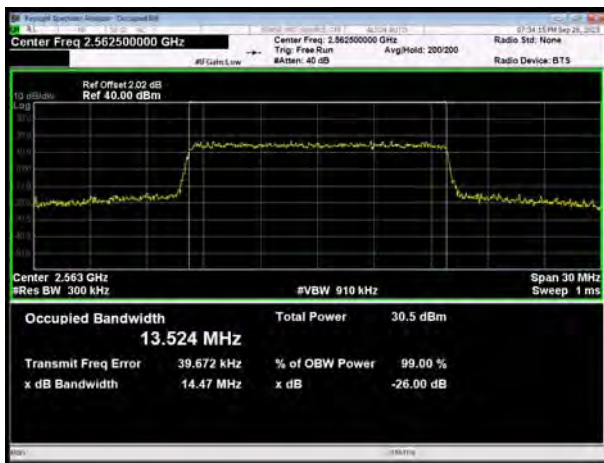

LTE Band 7 16QAM 20MHz CH-High



LTE Band 7 64QAM 5MHz CH-Low



LTE Band 7 64QAM 10MHz CH-Low



LTE Band 7 64QAM 5MHz CH-Middle

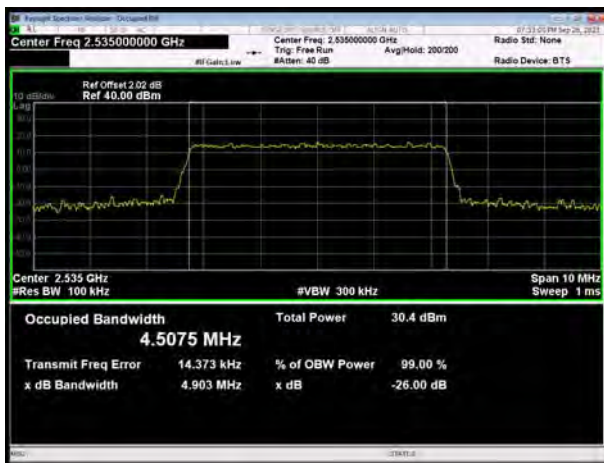

LTE Band 7 64QAM 10MHz CH-Middle



LTE Band 7 64QAM 5MHz CH-High

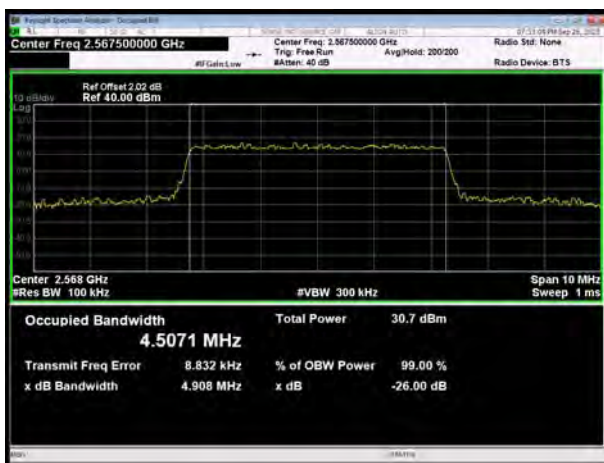

LTE Band 7 64QAM 10MHz CH-High

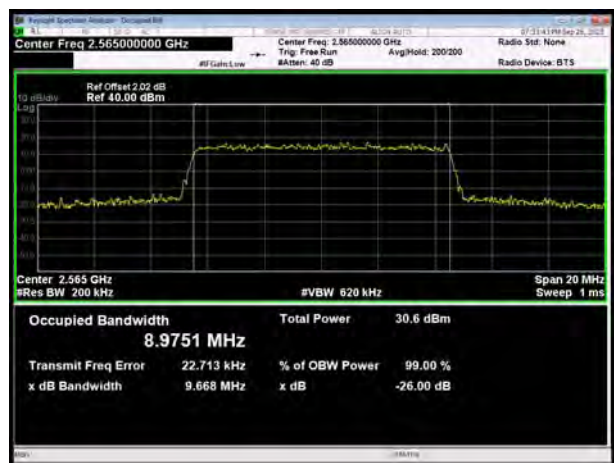

LTE Band 7 64QAM 15MHz CH-Low



LTE Band 7 64QAM 20MHz CH-Low



LTE Band 7 64QAM 15MHz CH-Middle



LTE Band 7 64QAM 20MHz CH-Middle



LTE Band 7 64QAM 15MHz CH-High

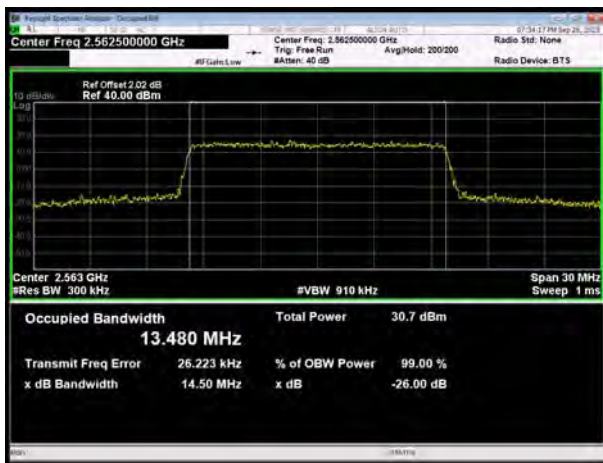

LTE Band 7 64QAM 20MHz CH-High

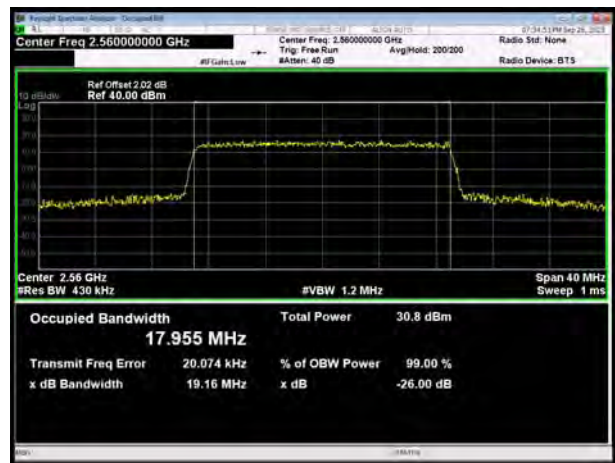

LTE Band 12 QPSK 1.4MHz CH-Low



LTE Band 12 QPSK 3MHz CH-Low



LTE Band 12 QPSK 1.4MHz CH-Middle

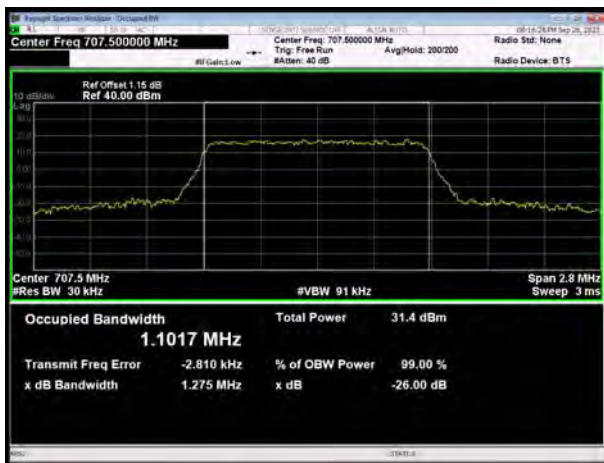

LTE Band 12 QPSK 3MHz CH-Middle



LTE Band 12 QPSK 1.4MHz CH-High

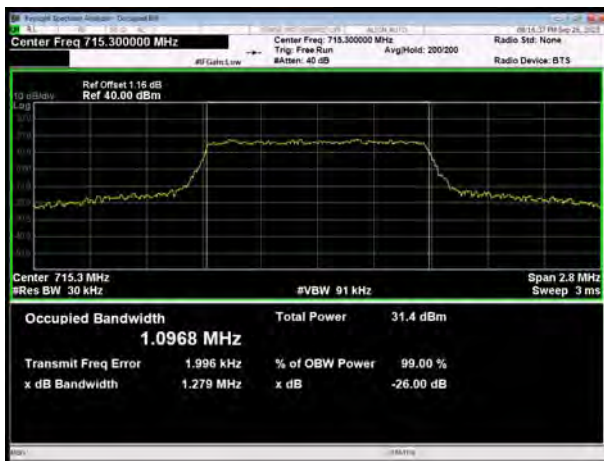

LTE Band 12 QPSK 3MHz CH-High

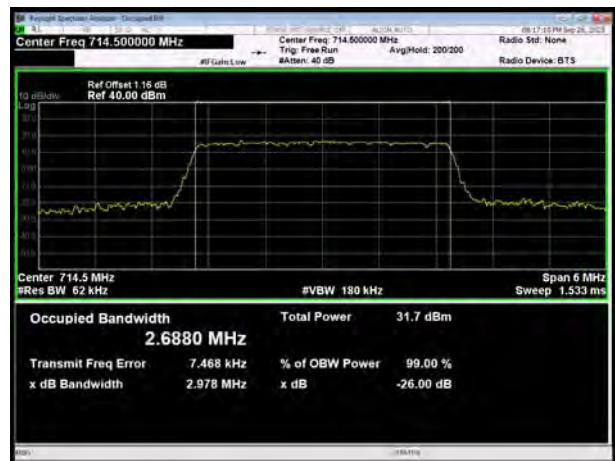

LTE Band 12 QPSK 5MHz CH-Low

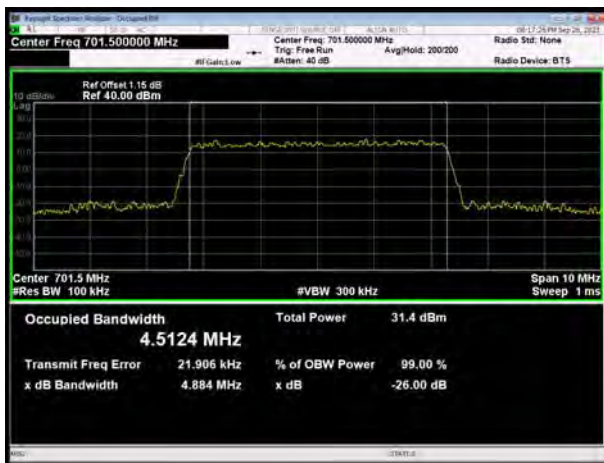

LTE Band 12 QPSK 10MHz CH-Low

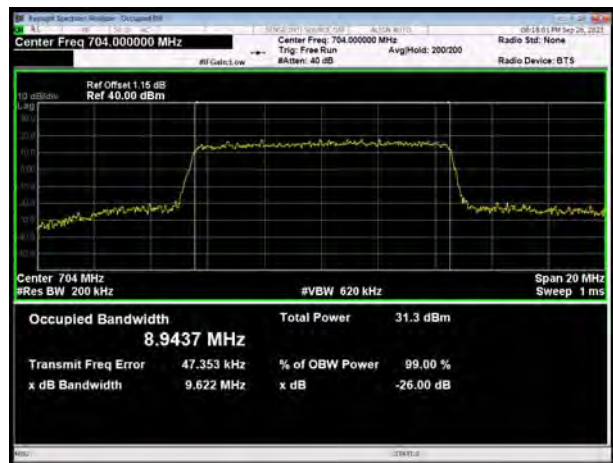

LTE Band 12 QPSK 5MHz CH-Middle



LTE Band 12 QPSK 10MHz CH-Middle

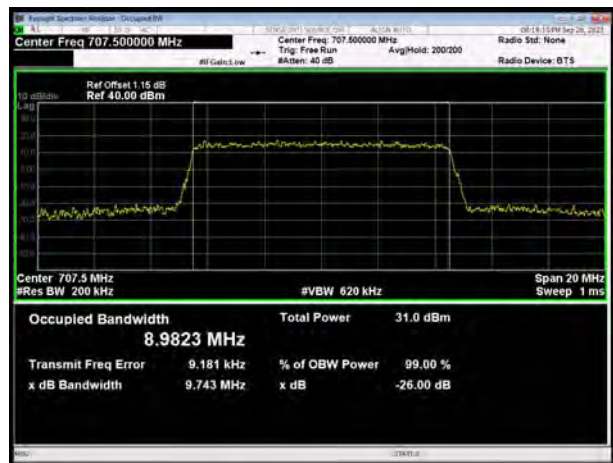

LTE Band 12 QPSK 5MHz CH-High

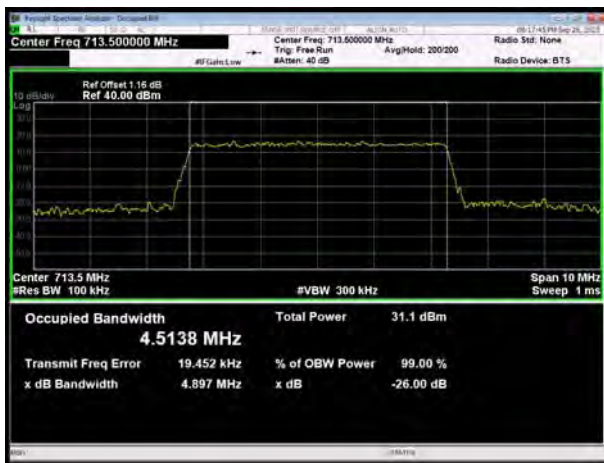

LTE Band 12 QPSK 10MHz CH-High

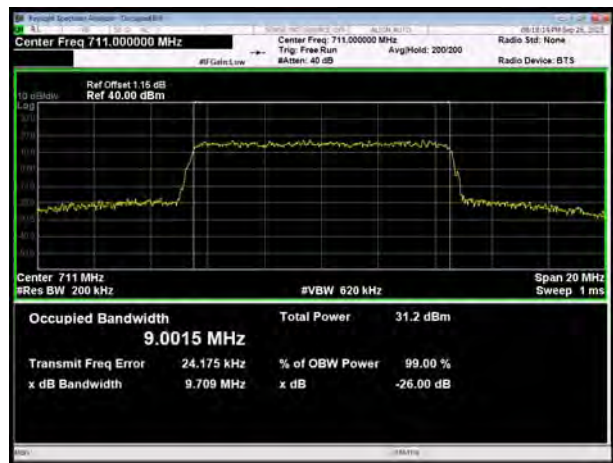

LTE Band 12 16QAM 1.4MHz CH-Low

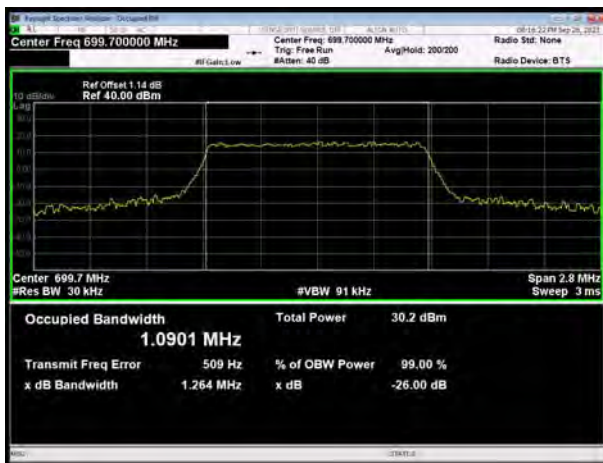

LTE Band 12 16QAM 3MHz CH-Low



LTE Band 12 16QAM 1.4MHz CH-Middle

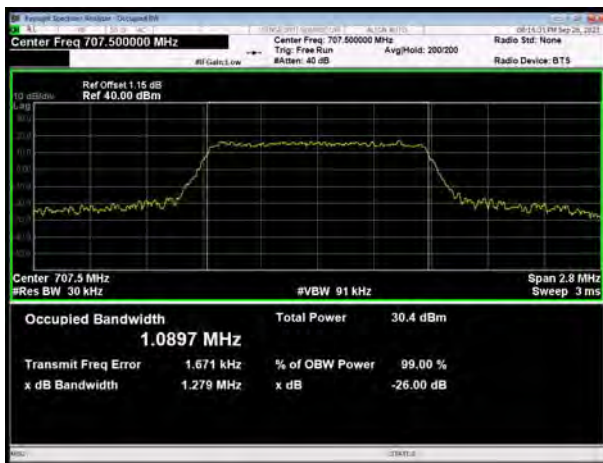

LTE Band 12 16QAM 3MHz CH-Middle

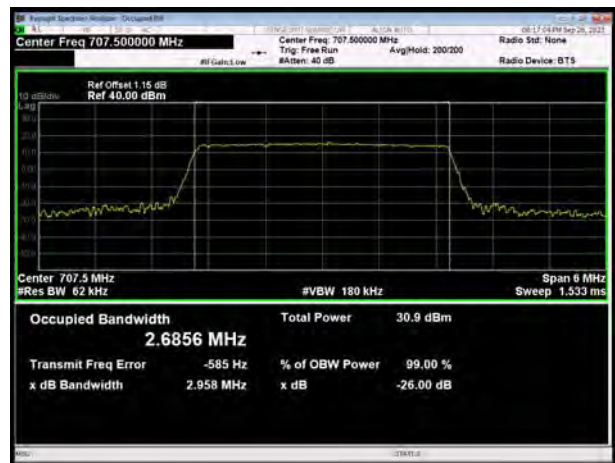

LTE Band 12 16QAM 1.4MHz CH-High

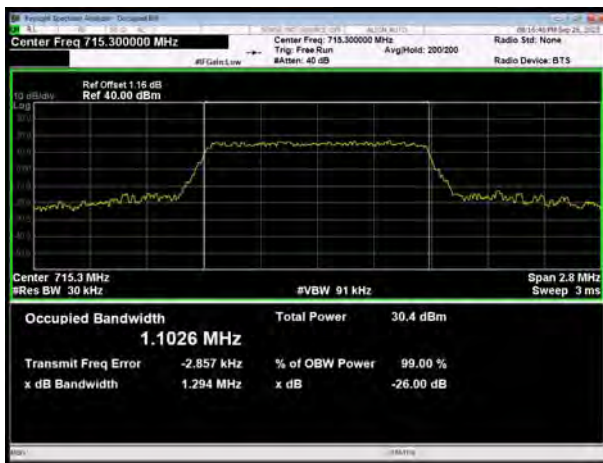

LTE Band 12 16QAM 3MHz CH-High

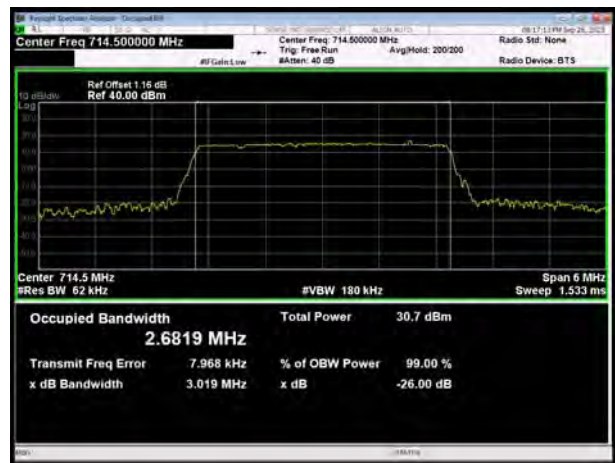

LTE Band 12 16QAM 5MHz CH-Low



LTE Band 12 16QAM 10MHz CH-Low



LTE Band 12 16QAM 5MHz CH-Middle

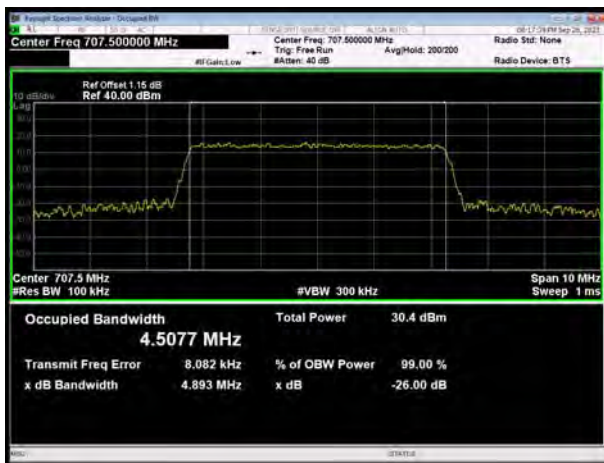

LTE Band 12 16QAM 10MHz CH-Middle



LTE Band 12 16QAM 5MHz CH-High

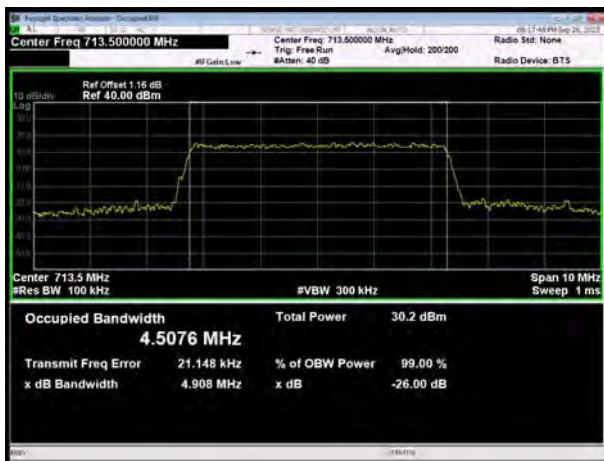

LTE Band 12 16QAM 10MHz CH-High

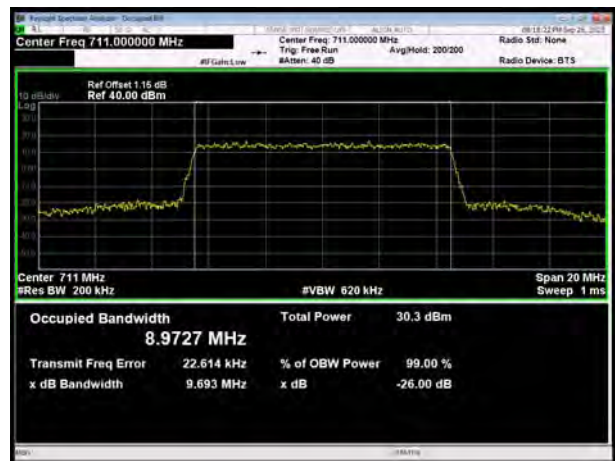

LTE Band 12 64QAM 1.4MHz CH-Low

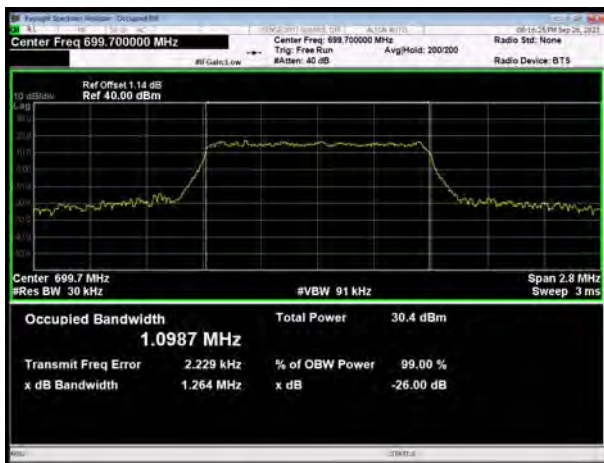

LTE Band 12 64QAM 3MHz CH-Low

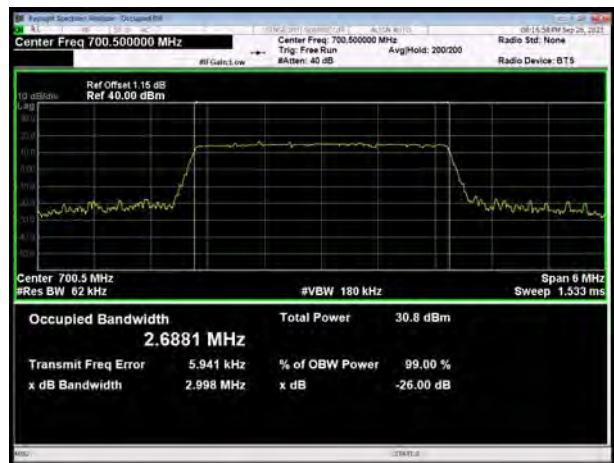

LTE Band 12 64QAM 1.4MHz CH-Middle



LTE Band 12 64QAM 3MHz CH-Middle



LTE Band 12 64QAM 1.4MHz CH-High

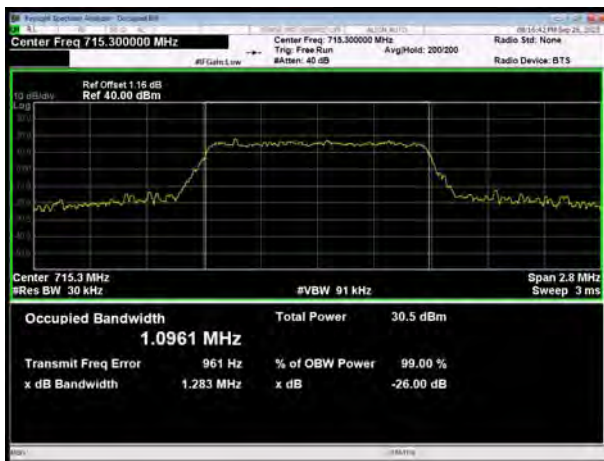

LTE Band 12 64QAM 3MHz CH-High

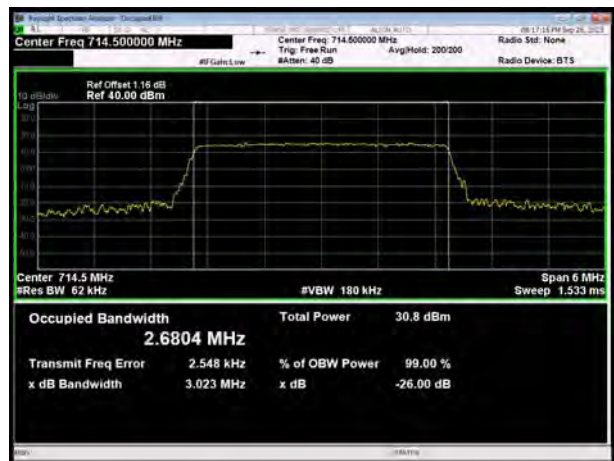

LTE Band 12 64QAM 5MHz CH-Low



LTE Band 12 64QAM 10MHz CH-Low



LTE Band 12 64QAM 5MHz CH-Middle



LTE Band 12 64QAM 10MHz CH-Middle



LTE Band 12 64QAM 5MHz CH-High

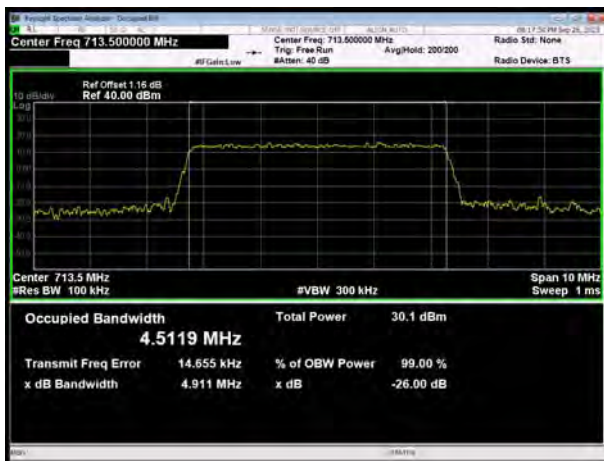

LTE Band 12 64QAM 10MHz CH-High

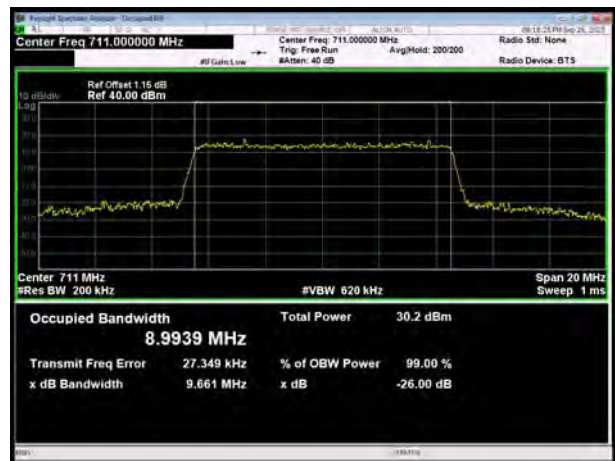

LTE Band 13 QPSK 5MHz CH-Low

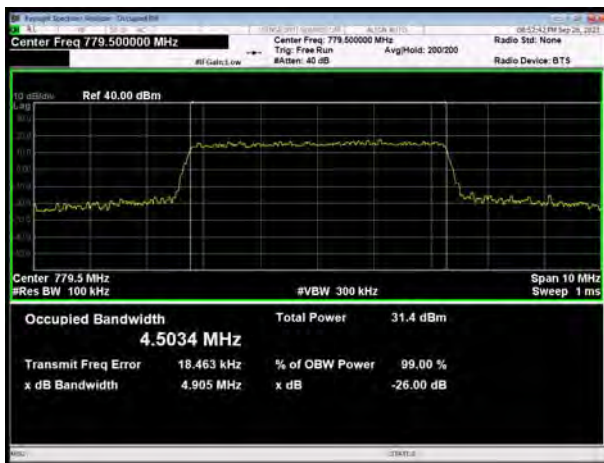

LTE Band 13 QPSK 5MHz CH-Middle



LTE Band 13 QPSK 10MHz CH-Middle



LTE Band 13 QPSK 5MHz CH-High



LTE Band 13 16QAM 5MHz CH-Low

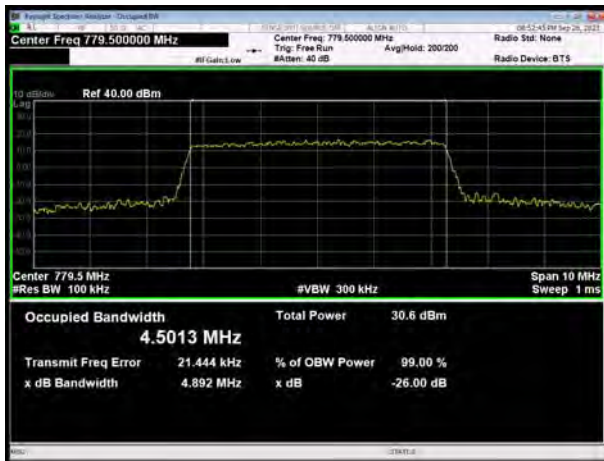

LTE Band 13 16QAM 5MHz CH-Middle



LTE Band 13 16QAM 10MHz CH-Middle



LTE Band 13 16QAM 5MHz CH-High

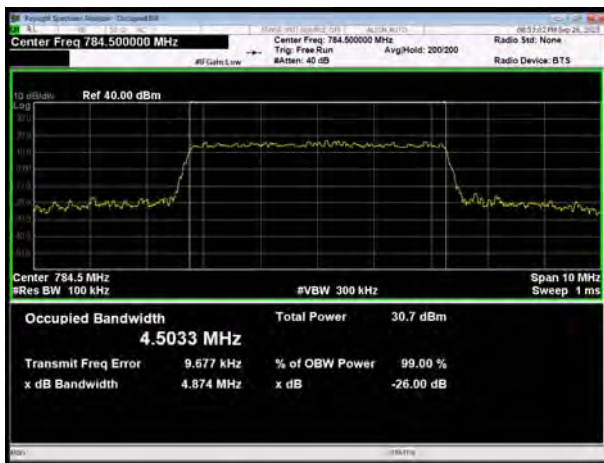

LTE Band 13 64QAM 5MHz CH-Low



LTE Band 13 64QAM 5MHz CH-Middle



LTE Band 13 64QAM 10MHz CH-Middle



LTE Band 13 64QAM 5MHz CH-High



LTE Band 17 QPSK 5MHz CH-Low



LTE Band 17 QPSK 10MHz CH-Low



LTE Band 17 QPSK 5MHz CH-Middle

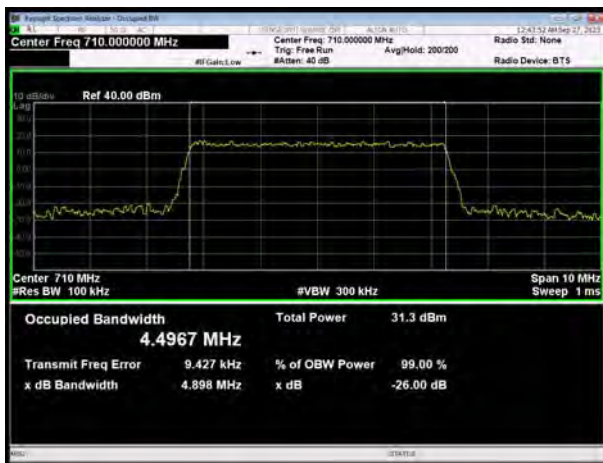

LTE Band 17 QPSK 10MHz CH-Middle



LTE Band 17 QPSK 5MHz CH-High

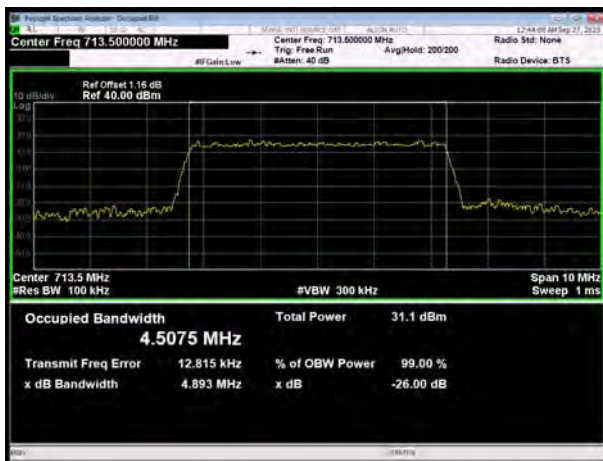

LTE Band 17 QPSK 10MHz CH-High

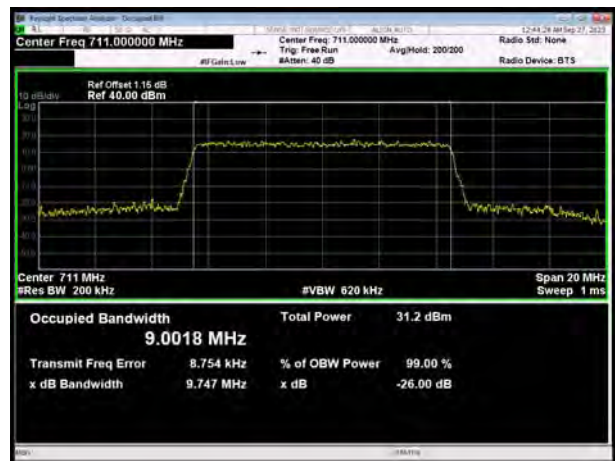

LTE Band 17 16QAM 5MHz CH-Low



LTE Band 17 16QAM 10MHz CH-Low



LTE Band 17 16QAM 5MHz CH-Middle

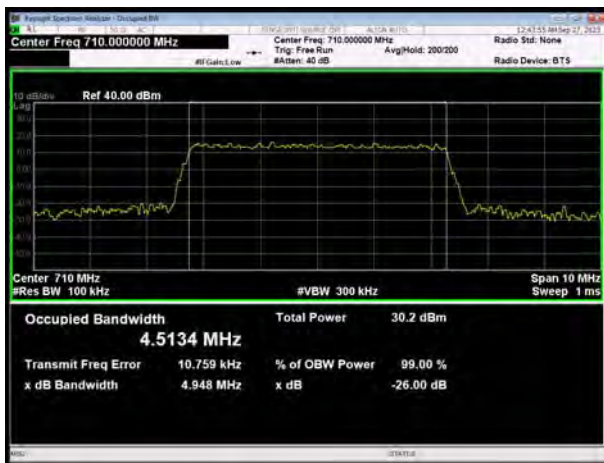

LTE Band 17 16QAM 10MHz CH-Middle



LTE Band 17 16QAM 5MHz CH-High



LTE Band 17 16QAM 10MHz CH-High



LTE Band 17 64QAM 5MHz CH-Low



LTE Band 17 64QAM 10MHz CH-Low

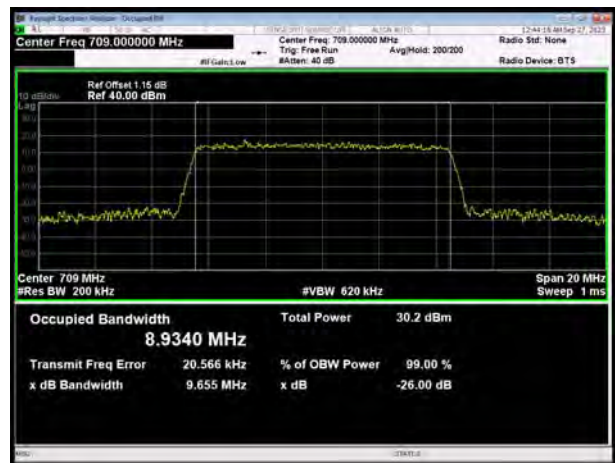

LTE Band 17 64QAM 5MHz CH-Middle



LTE Band 17 64QAM 10MHz CH-Middle

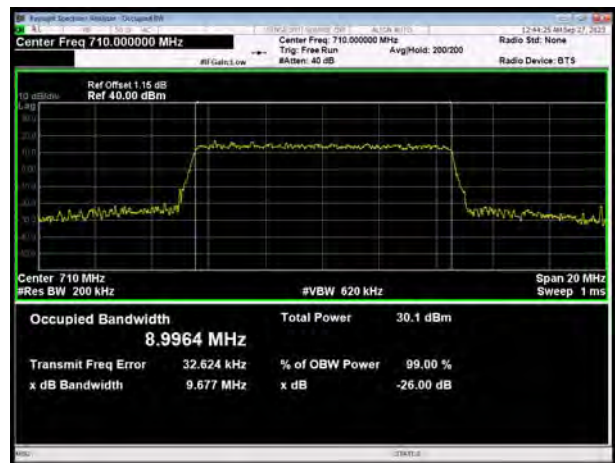

LTE Band 17 64QAM 5MHz CH-High

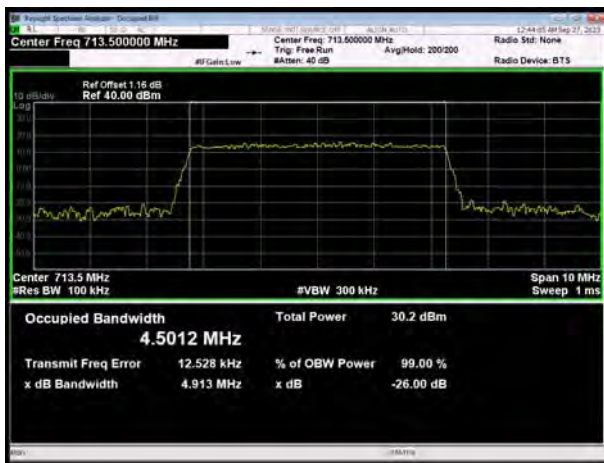

LTE Band 17 64QAM 10MHz CH-High

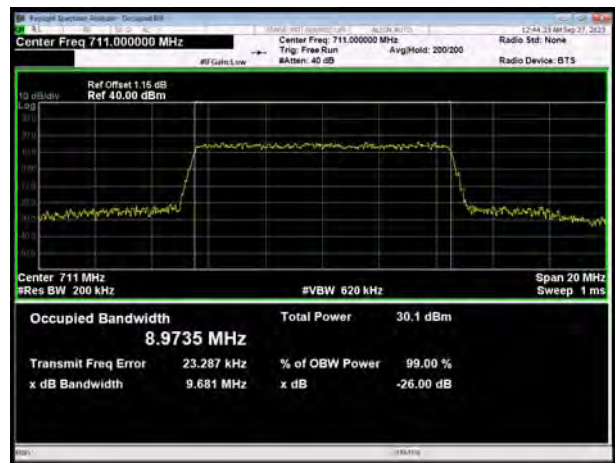

LTE Band 38 QPSK 5MHz CH-Low



LTE Band 38 QPSK 10MHz CH-Low



LTE Band 38 QPSK 5MHz CH-Middle



LTE Band 38 QPSK 10MHz CH-Middle



LTE Band 38 QPSK 5MHz CH-High



LTE Band 38 QPSK 10MHz CH-High

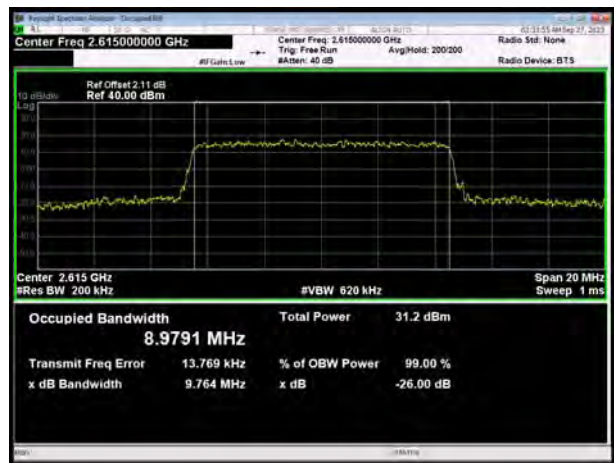

LTE Band 38 QPSK 15MHz CH-Low



LTE Band 38 QPSK 20MHz CH-Low

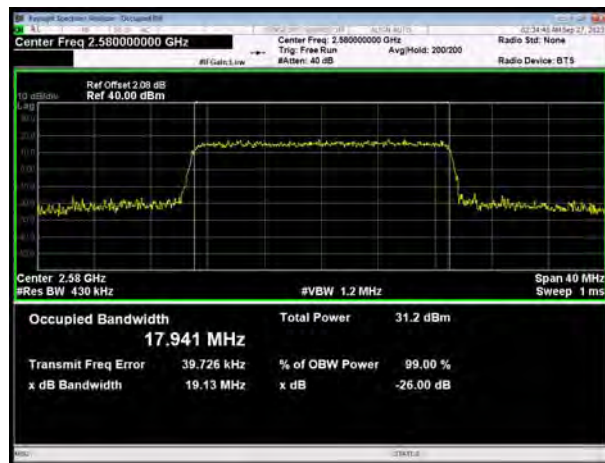

LTE Band 38 QPSK 15MHz CH-Middle



LTE Band 38 QPSK 20MHz CH-Middle

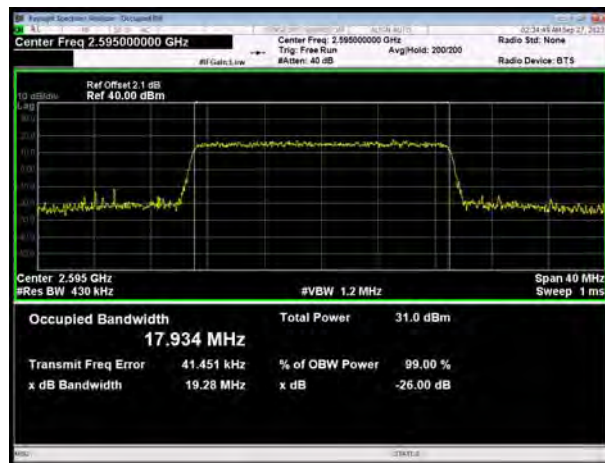

LTE Band 38 QPSK 15MHz CH-High

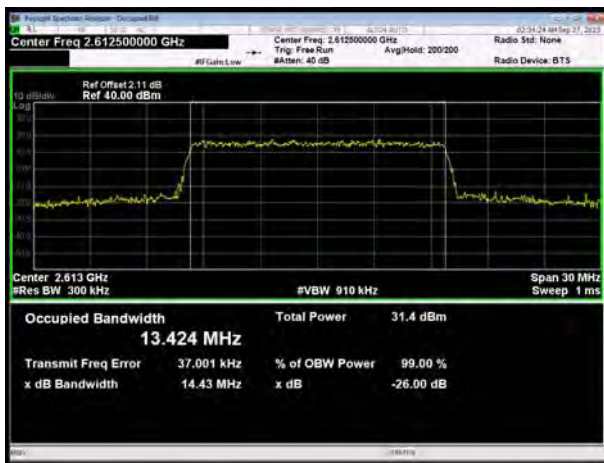

LTE Band 38 QPSK 20MHz CH-High

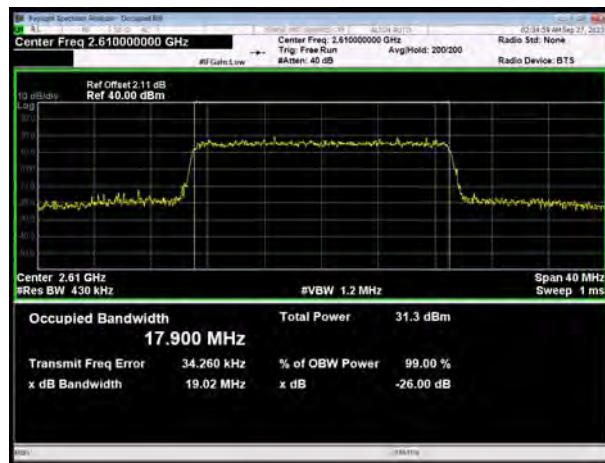

LTE Band 38 16QAM 5MHz CH-Low



LTE Band 38 16QAM 10MHz CH-Low



LTE Band 38 16QAM 5MHz CH-Middle



LTE Band 38 16QAM 10MHz CH-Middle

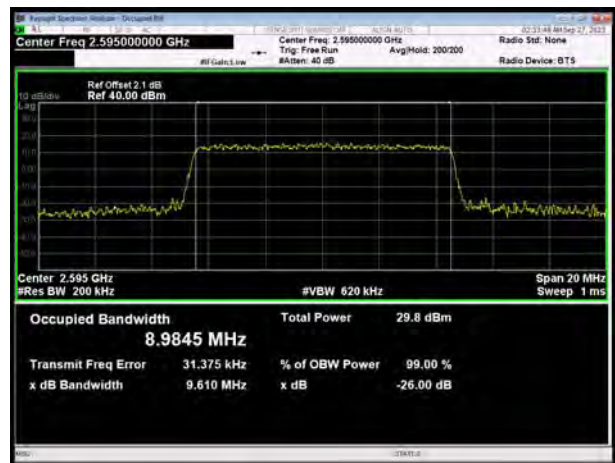

LTE Band 38 16QAM 5MHz CH-High

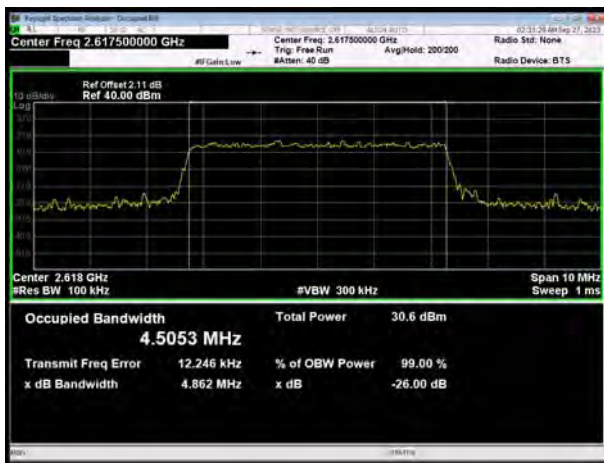

LTE Band 38 16QAM 10MHz CH-High

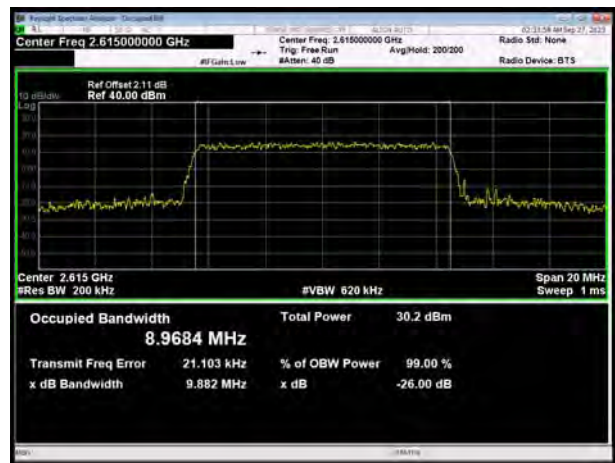

LTE Band 38 16QAM 15MHz CH-Low

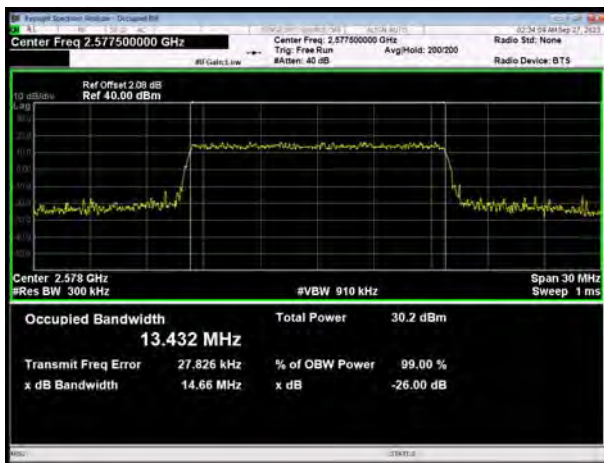

LTE Band 38 16QAM 20MHz CH-Low

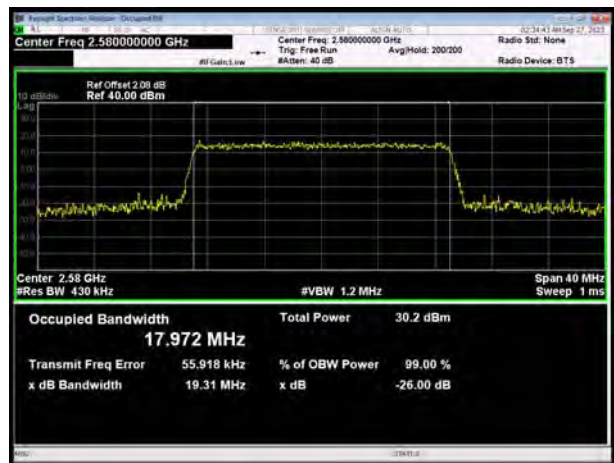

LTE Band 38 16QAM 15MHz CH-Middle

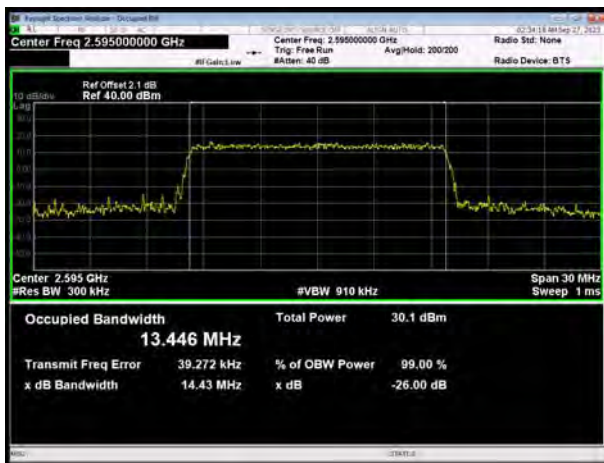

LTE Band 38 16QAM 20MHz CH-Middle

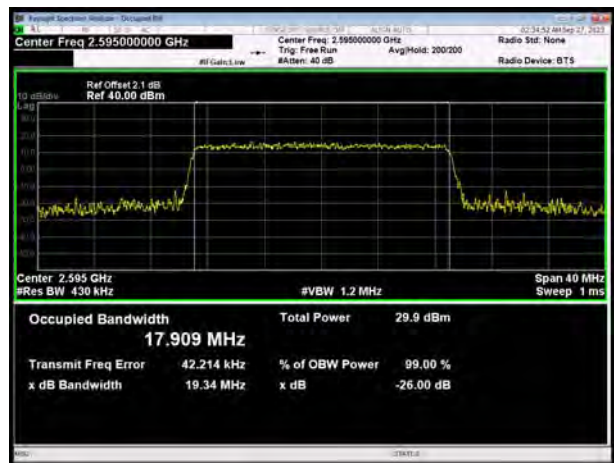

LTE Band 38 16QAM 15MHz CH-High

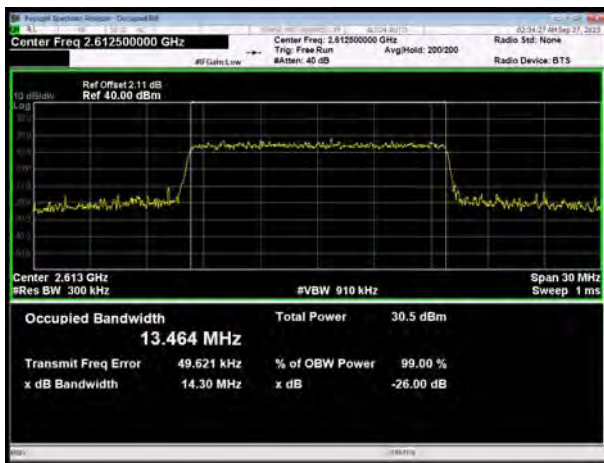

LTE Band 38 16QAM 20MHz CH-High

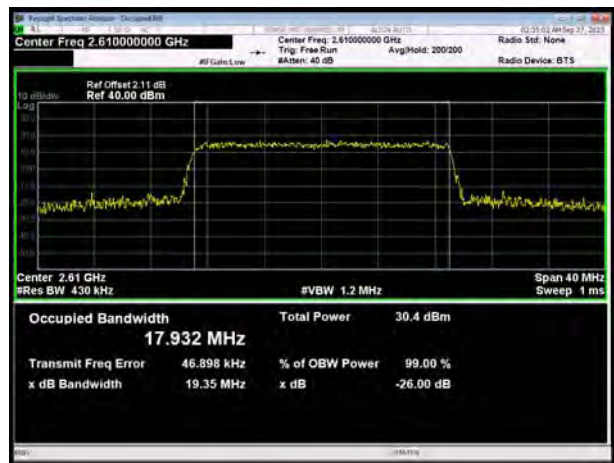

LTE Band 38 64QAM 5MHz CH-Low



LTE Band 38 64QAM 10MHz CH-Low

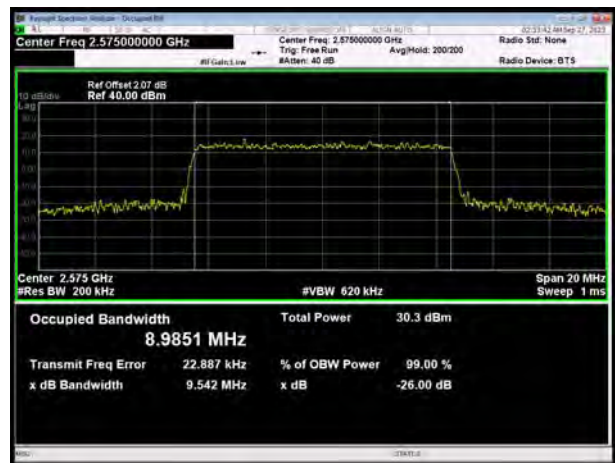

LTE Band 38 64QAM 5MHz CH-Middle

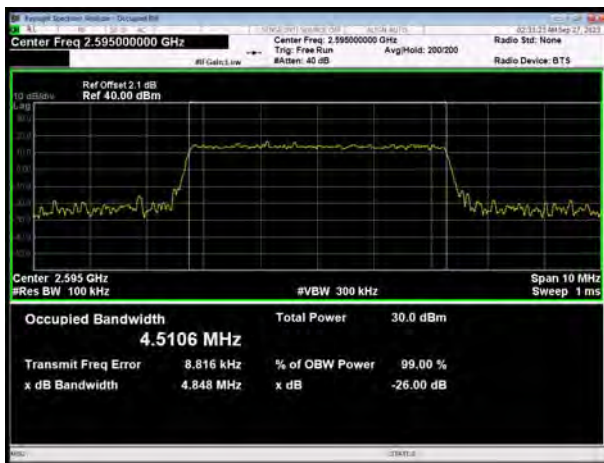

LTE Band 38 64QAM 10MHz CH-Middle



LTE Band 38 64QAM 5MHz CH-High

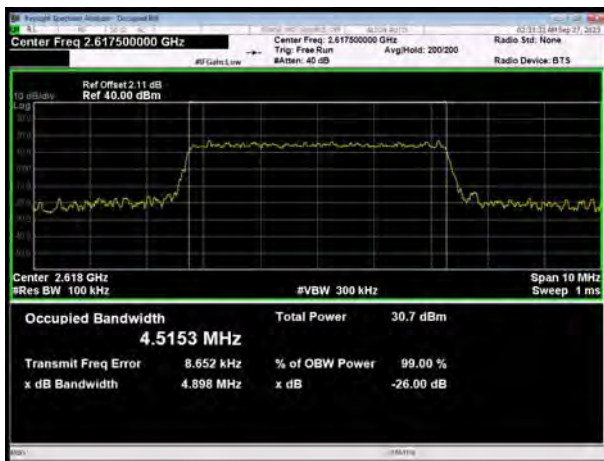

LTE Band 38 64QAM 10MHz CH-High

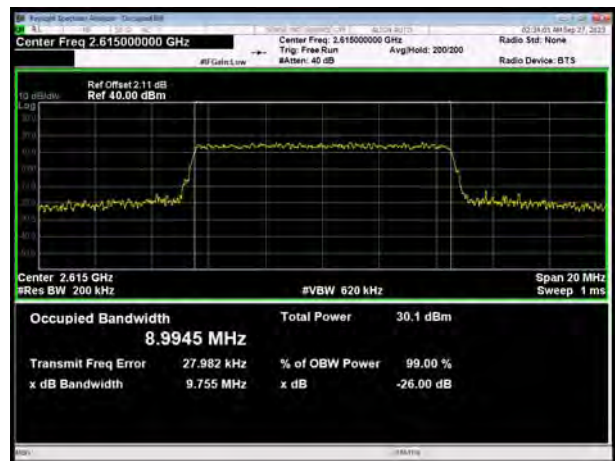

LTE Band 38 64QAM 15MHz CH-Low



LTE Band 38 64QAM 20MHz CH-Low

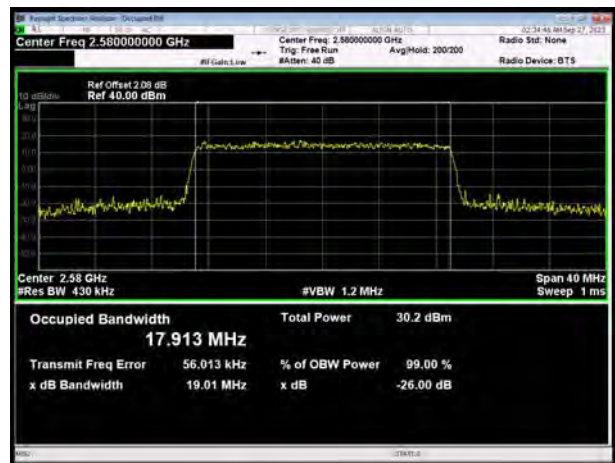

LTE Band 38 64QAM 15MHz CH-Middle



LTE Band 38 64QAM 20MHz CH-Middle



LTE Band 38 64QAM 15MHz CH-High

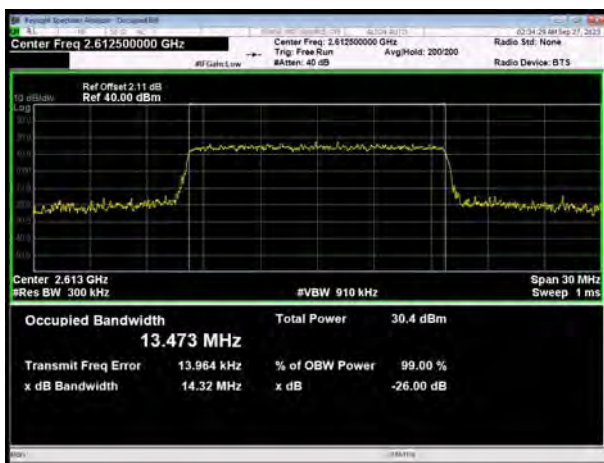

LTE Band 38 64QAM 20MHz CH-High

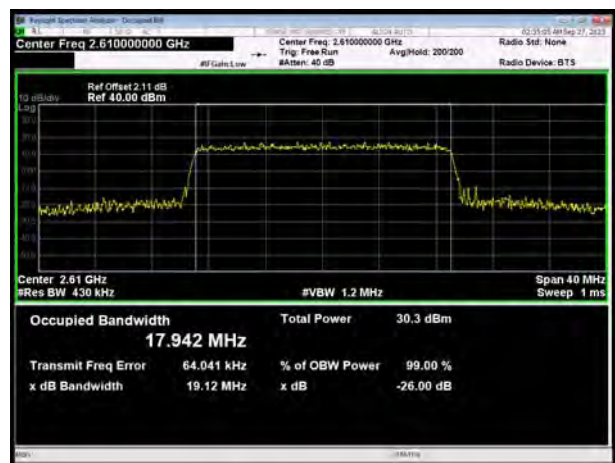

LTE Band 41 QPSK 5MHz CH-Low

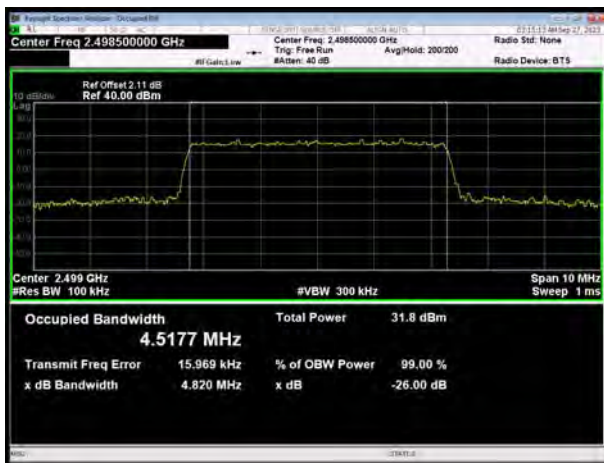

LTE Band 41 QPSK 10MHz CH-Low



LTE Band 41 QPSK 5MHz CH-Middle



LTE Band 41 QPSK 10MHz CH-Middle



LTE Band 41 QPSK 5MHz CH-High

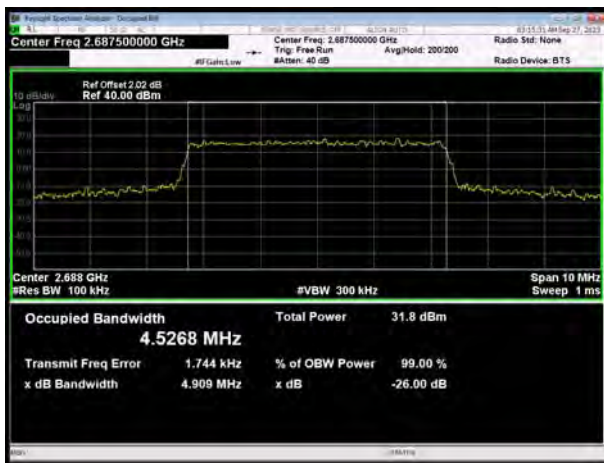

LTE Band 41 QPSK 10MHz CH-High

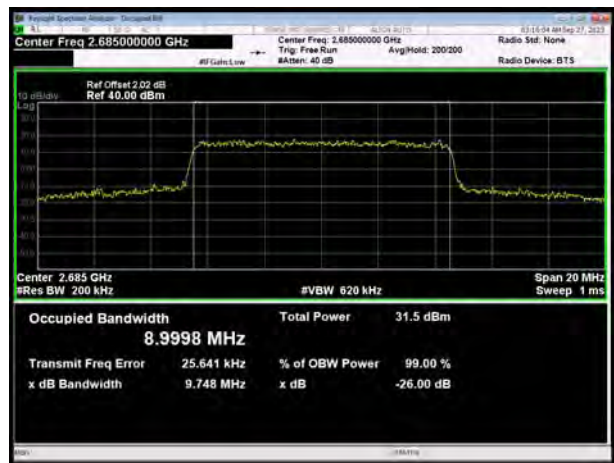

LTE Band 41 QPSK 15MHz CH-Low



LTE Band 41 QPSK 20MHz CH-Low

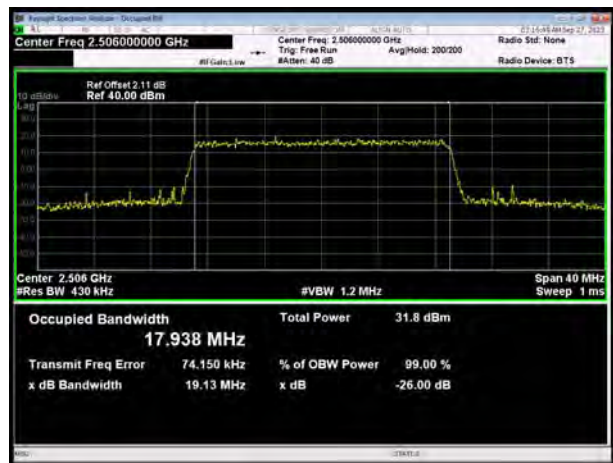

LTE Band 41 QPSK 15MHz CH-Middle

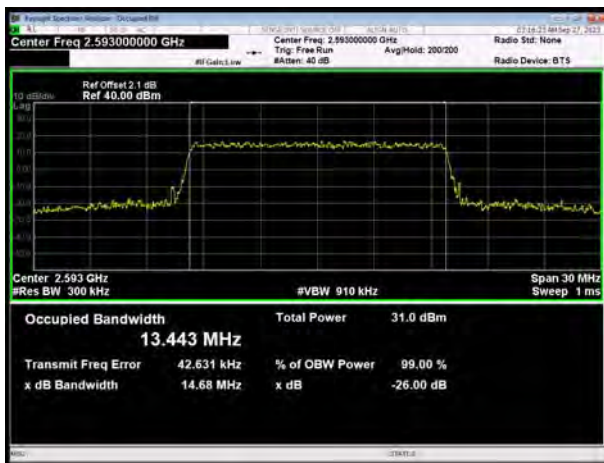

LTE Band 41 QPSK 20MHz CH-Middle



LTE Band 41 QPSK 15MHz CH-High

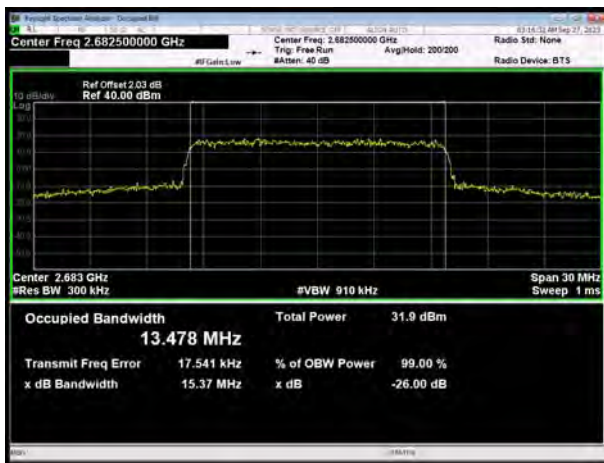

LTE Band 41 QPSK 20MHz CH-High

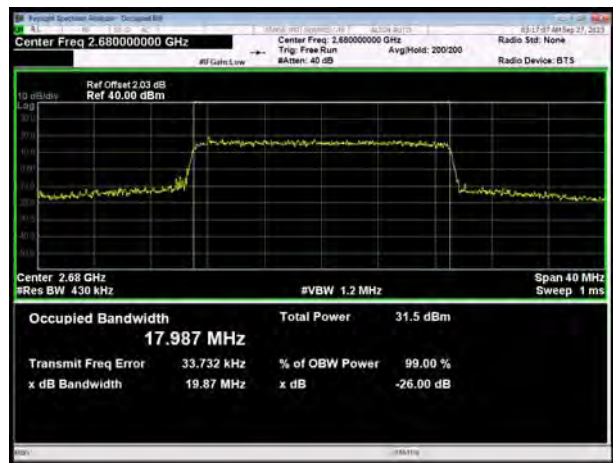

LTE Band 41 16QAM 5MHz CH-Low



LTE Band 41 16QAM 10MHz CH-Low

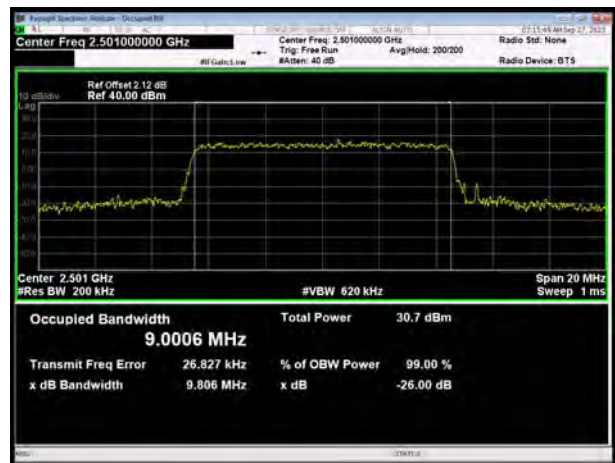

LTE Band 41 16QAM 5MHz CH-Middle



LTE Band 41 16QAM 10MHz CH-Middle

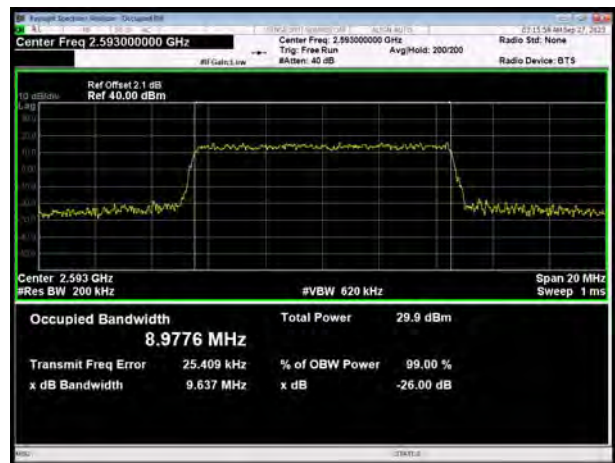

LTE Band 41 16QAM 5MHz CH-High

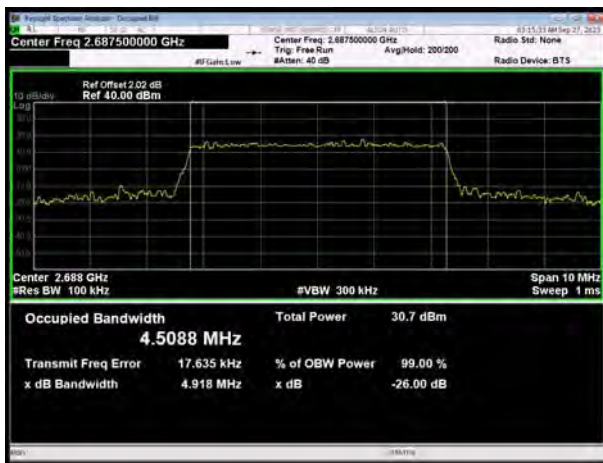

LTE Band 41 16QAM 10MHz CH-High

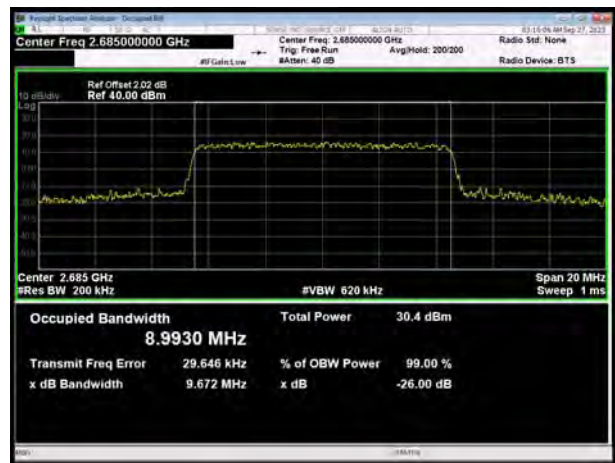

LTE Band 41 16QAM 15MHz CH-Low

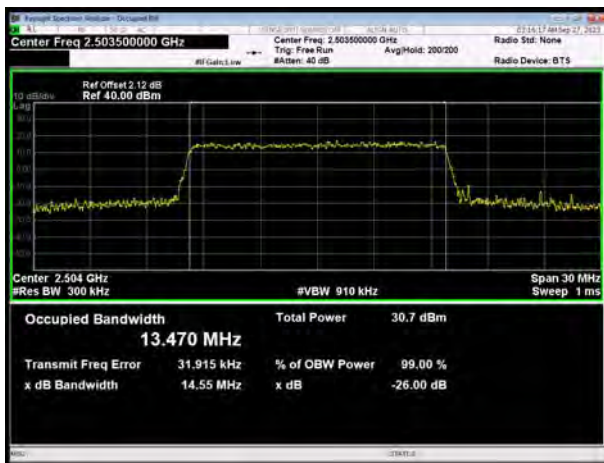

LTE Band 41 16QAM 20MHz CH-Low

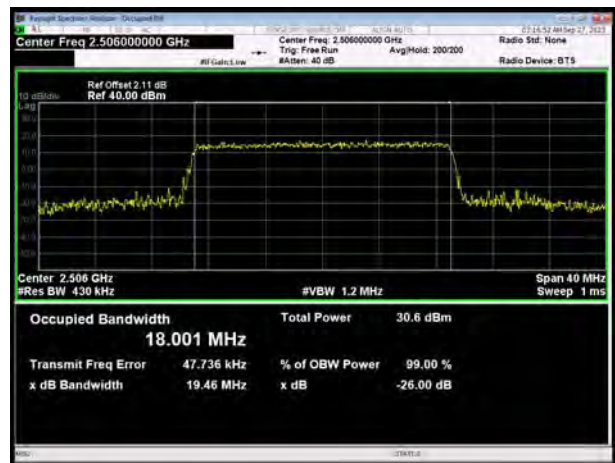

LTE Band 41 16QAM 15MHz CH-Middle



LTE Band 41 16QAM 20MHz CH-Middle



LTE Band 41 16QAM 15MHz CH-High

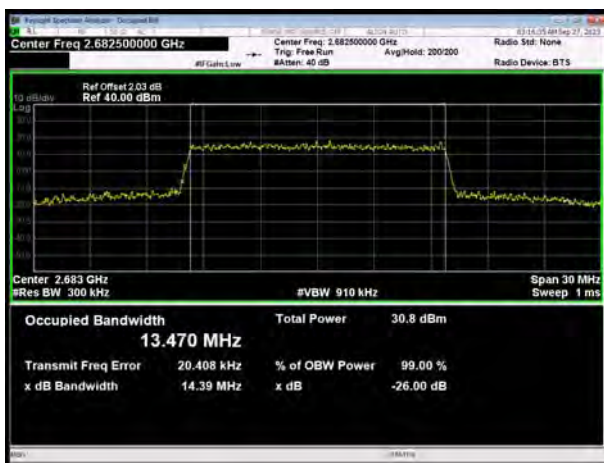

LTE Band 41 16QAM 20MHz CH-High

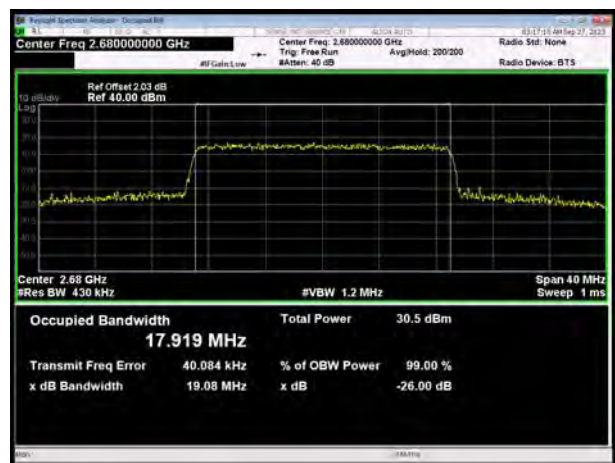

LTE Band 41 64QAM 5MHz CH-Low

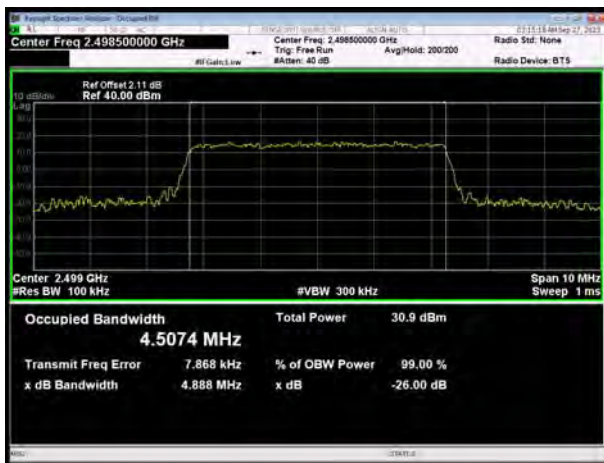

LTE Band 41 64QAM 10MHz CH-Low



LTE Band 41 64QAM 5MHz CH-Middle



LTE Band 41 64QAM 10MHz CH-Middle



LTE Band 41 64QAM 5MHz CH-High

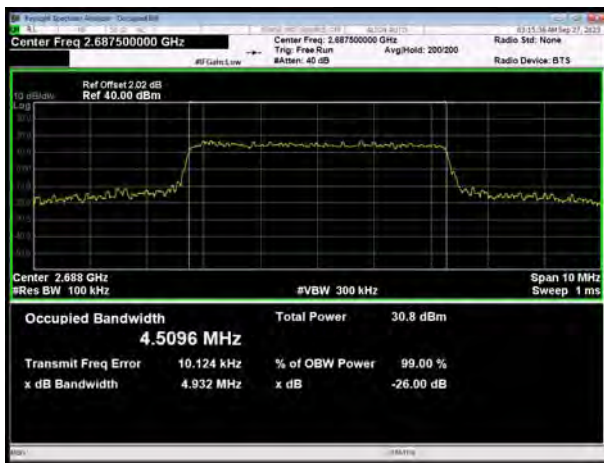

LTE Band 41 64QAM 10MHz CH-High

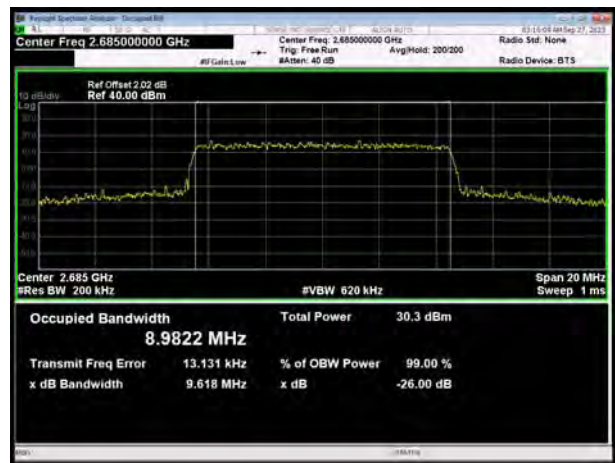

LTE Band 41 64QAM 15MHz CH-Low

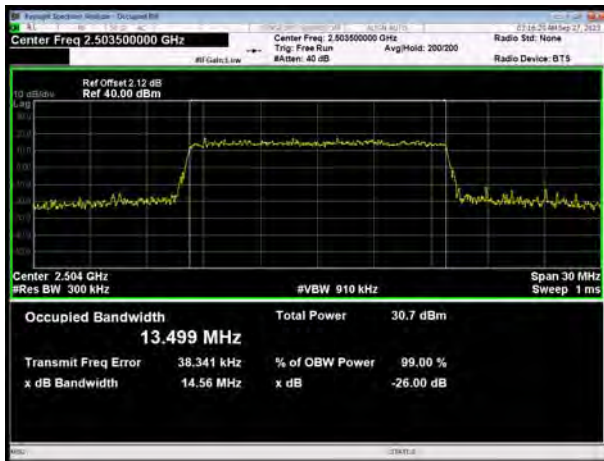

LTE Band 41 64QAM 20MHz CH-Low

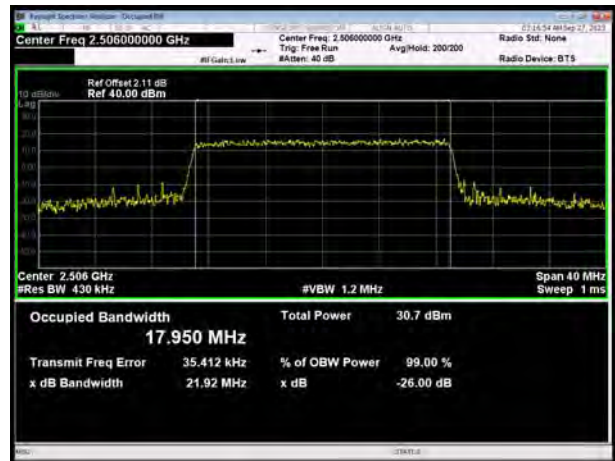

LTE Band 41 64QAM 15MHz CH-Middle



LTE Band 41 64QAM 20MHz CH-Middle



LTE Band 41 64QAM 15MHz CH-High

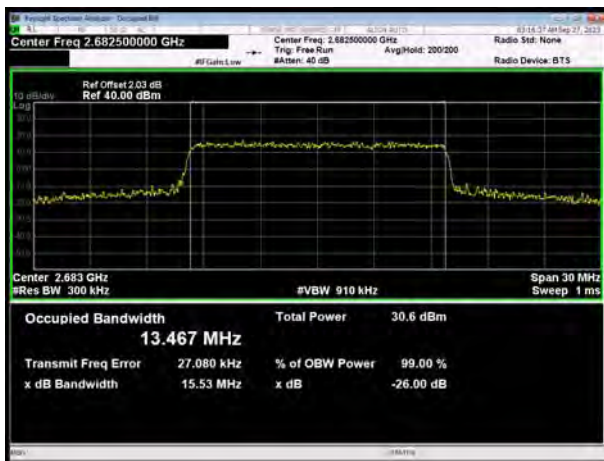

LTE Band 41 64QAM 20MHz CH-High

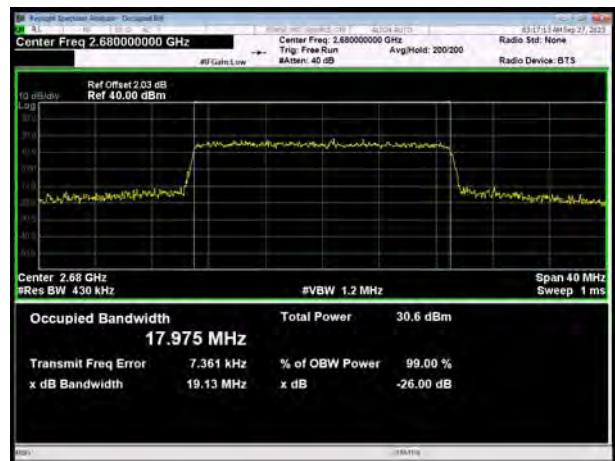

LTE Band 66 QPSK 1.4MHz CH-Low



LTE Band 66 QPSK 3MHz CH-Low



LTE Band 66 QPSK 1.4MHz CH-Middle

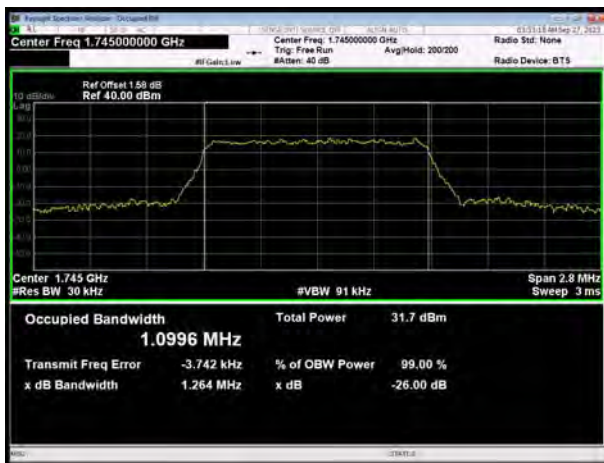

LTE Band 66 QPSK 3MHz CH-Middle

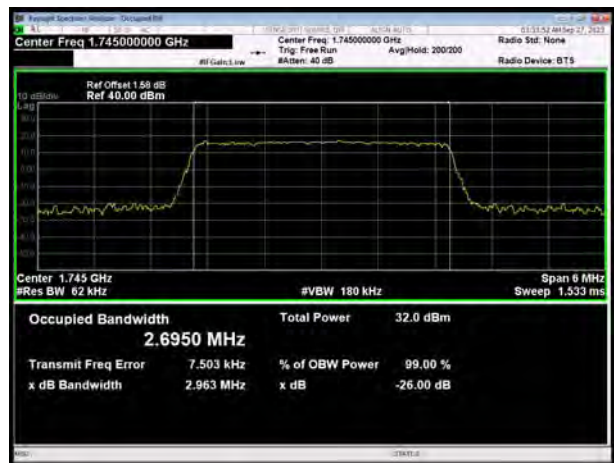

LTE Band 66 QPSK 1.4MHz CH-High

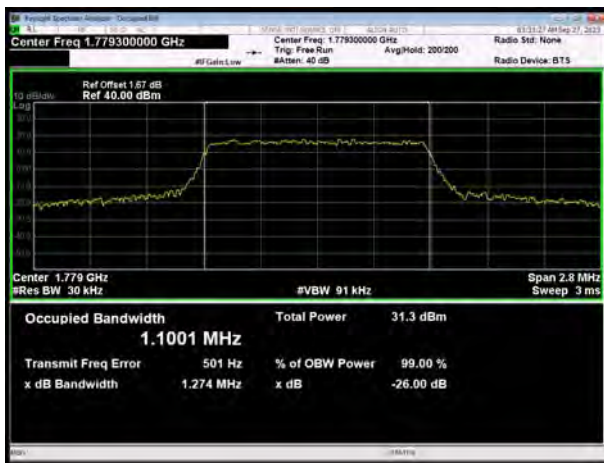

LTE Band 66 QPSK 3MHz CH-High

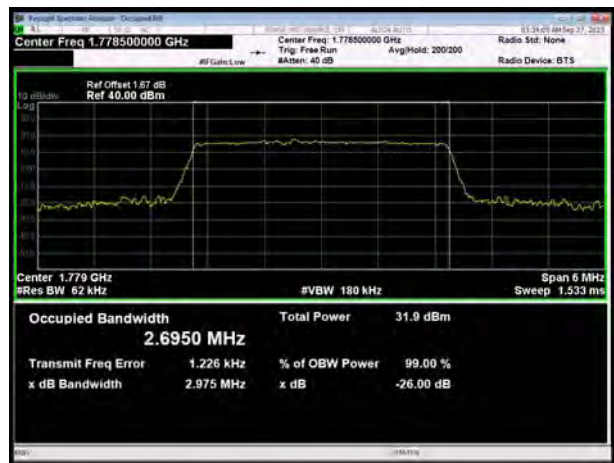

LTE Band 66 QPSK 5MHz CH-Low



LTE Band 66 QPSK 10MHz CH-Low



LTE Band 66 QPSK 5MHz CH-Middle



LTE Band 66 QPSK 10MHz CH-Middle



LTE Band 66 QPSK 5MHz CH-High

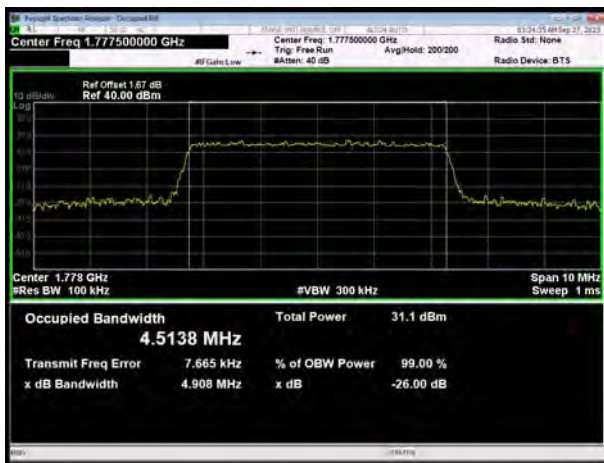

LTE Band 66 QPSK 10MHz CH-High

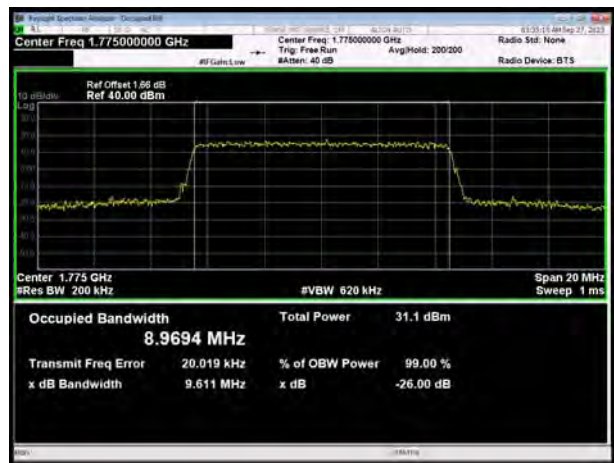

LTE Band 66 QPSK 15MHz CH-Low

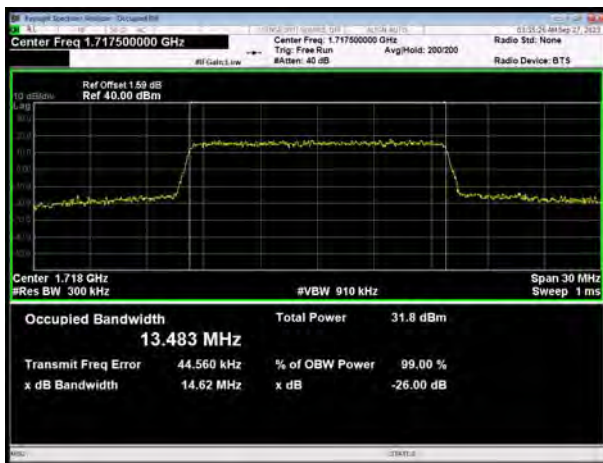

LTE Band 66 QPSK 20MHz CH-Low



LTE Band 66 QPSK 15MHz CH-Middle

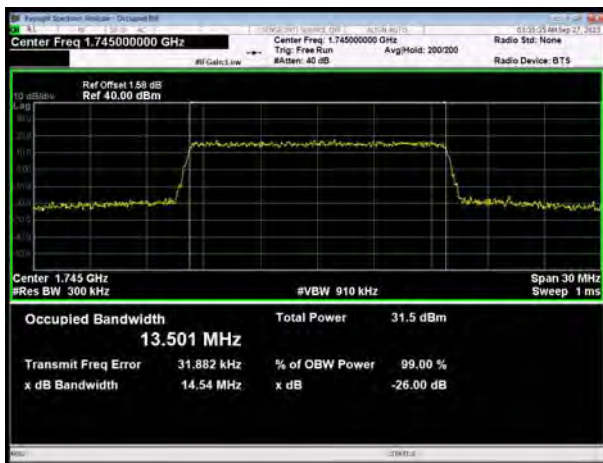

LTE Band 66 QPSK 20MHz CH-Middle

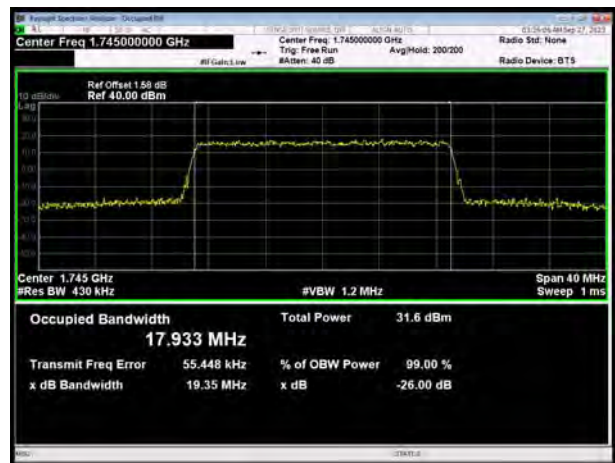

LTE Band 66 QPSK 15MHz CH-High

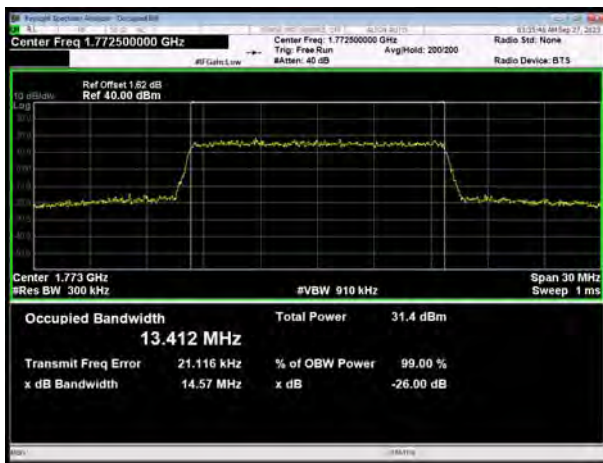

LTE Band 66 QPSK 20MHz CH-High

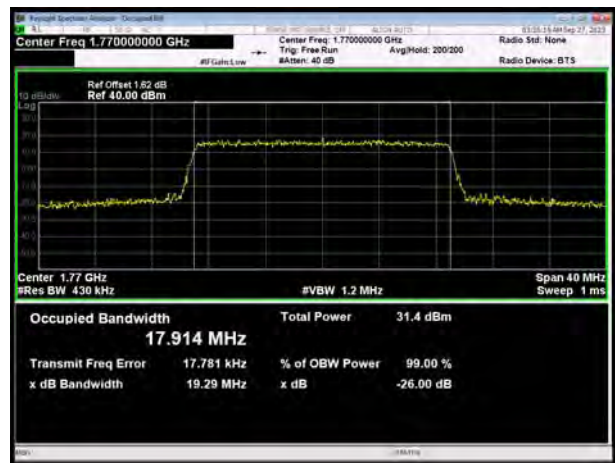

LTE Band 66 16QAM 1.4MHz CH-Low

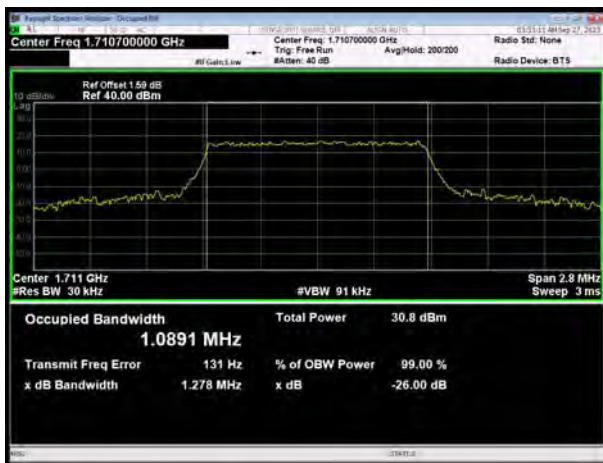

LTE Band 66 16QAM 3MHz CH-Low



LTE Band 66 16QAM 1.4MHz CH-Middle

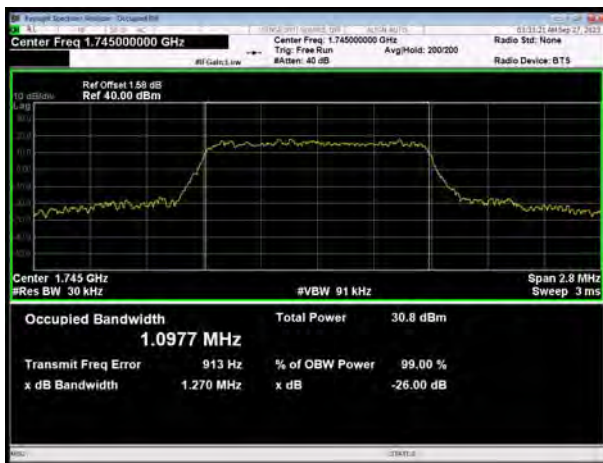

LTE Band 66 16QAM 3MHz CH-Middle

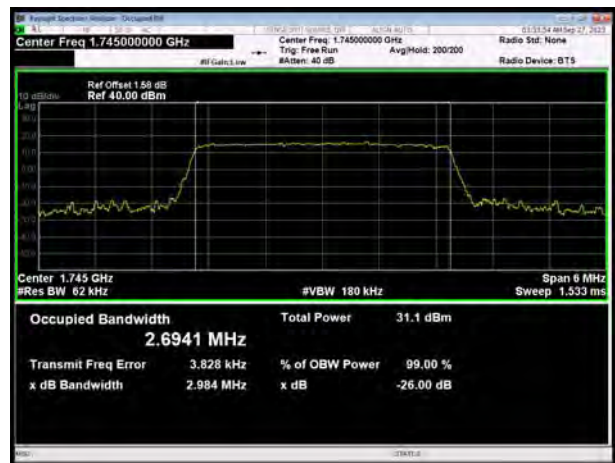

LTE Band 66 16QAM 1.4MHz CH-High

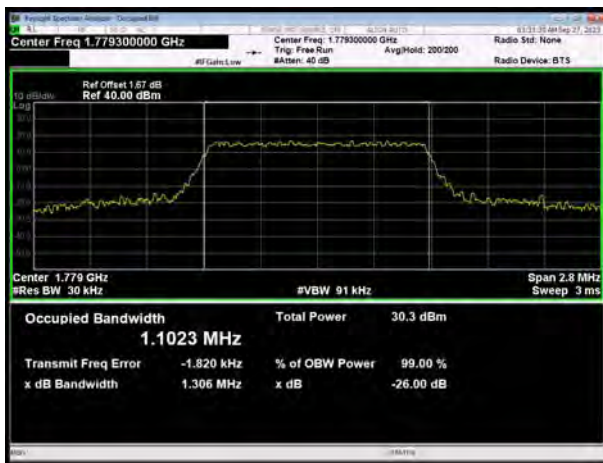

LTE Band 66 16QAM 3MHz CH-High

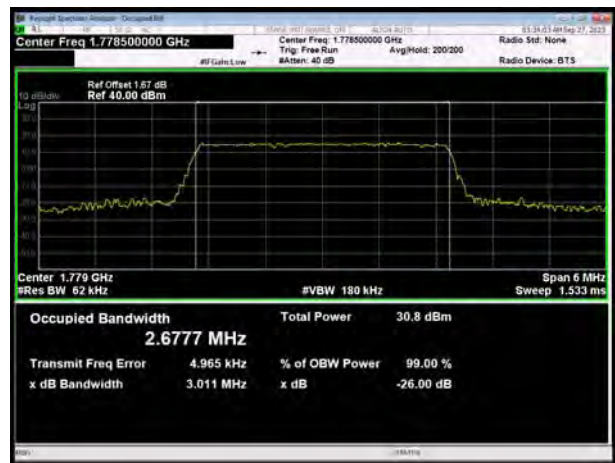

LTE Band 66 16QAM 5MHz CH-Low



LTE Band 66 16QAM 10MHz CH-Low



LTE Band 66 16QAM 5MHz CH-Middle



LTE Band 66 16QAM 10MHz CH-Middle



LTE Band 66 16QAM 5MHz CH-High

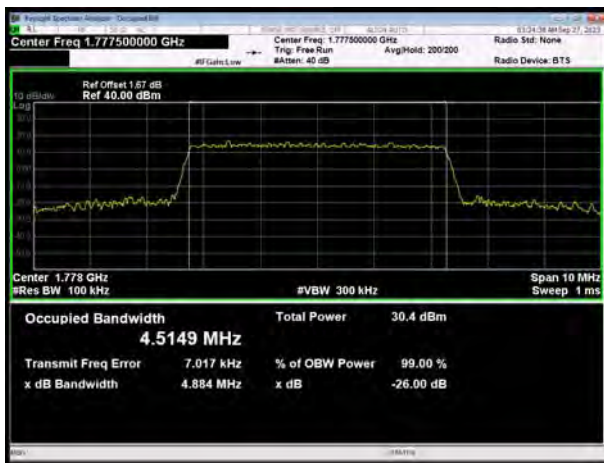

LTE Band 66 16QAM 10MHz CH-High

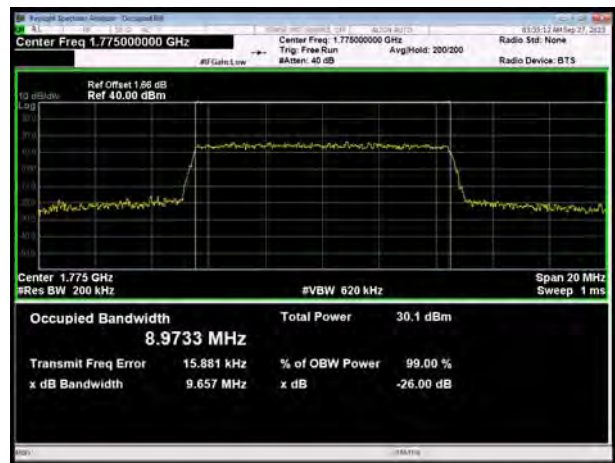

LTE Band 66 16QAM 15MHz CH-Low



LTE Band 66 16QAM 20MHz CH-Low



LTE Band 66 16QAM 15MHz CH-Middle



LTE Band 66 16QAM 20MHz CH-Middle



LTE Band 66 16QAM 15MHz CH-High

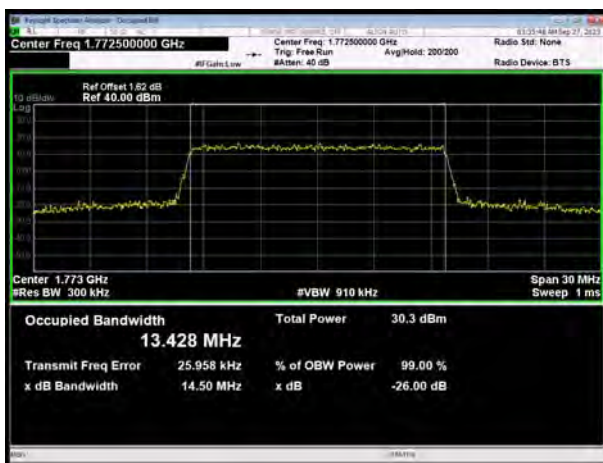

LTE Band 66 16QAM 20MHz CH-High

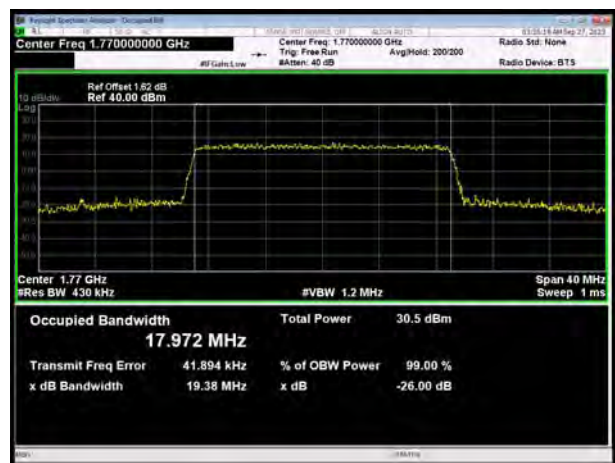

LTE Band 66 64QAM 1.4MHz CH-Low

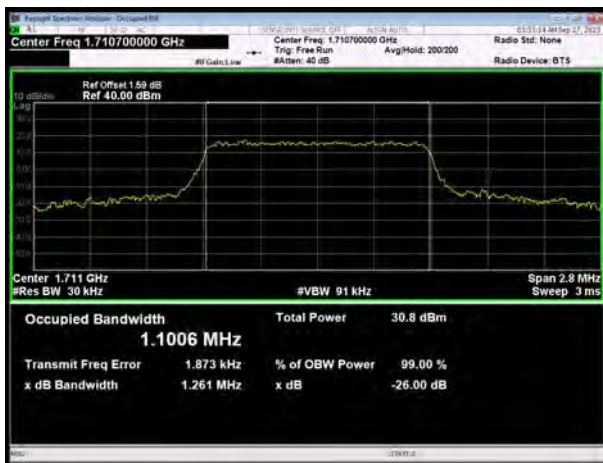

LTE Band 66 64QAM 3MHz CH-Low



LTE Band 66 64QAM 1.4MHz CH-Middle

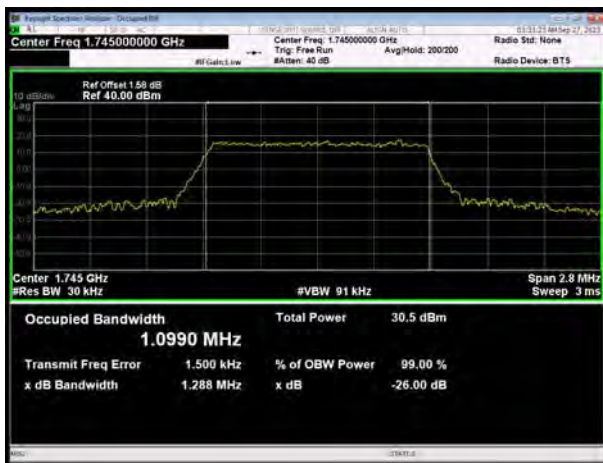

LTE Band 66 64QAM 3MHz CH-Middle

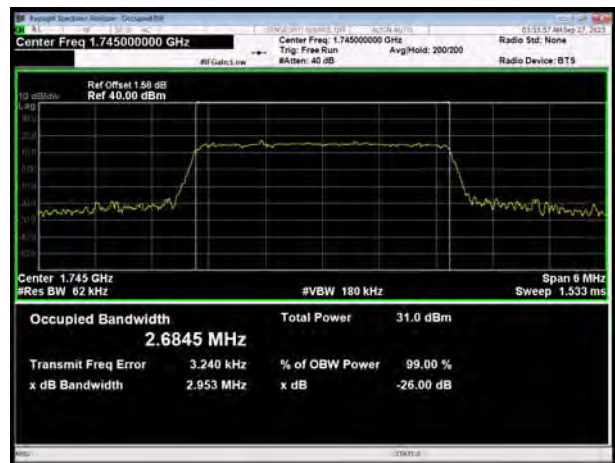

LTE Band 66 64QAM 1.4MHz CH-High

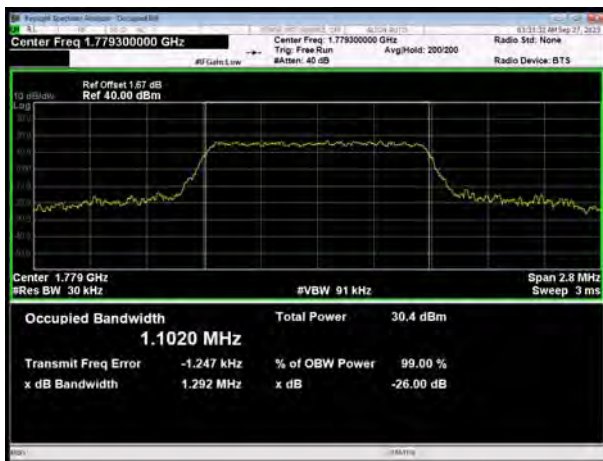

LTE Band 66 64QAM 3MHz CH-High

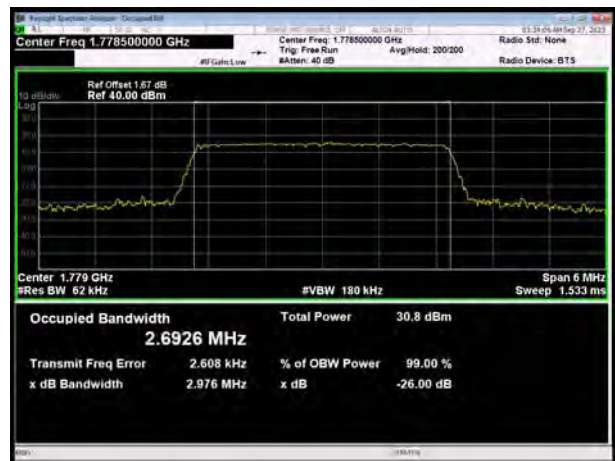

LTE Band 66 64QAM 5MHz CH-Low



LTE Band 66 64QAM 10MHz CH-Low



LTE Band 66 64QAM 5MHz CH-Middle

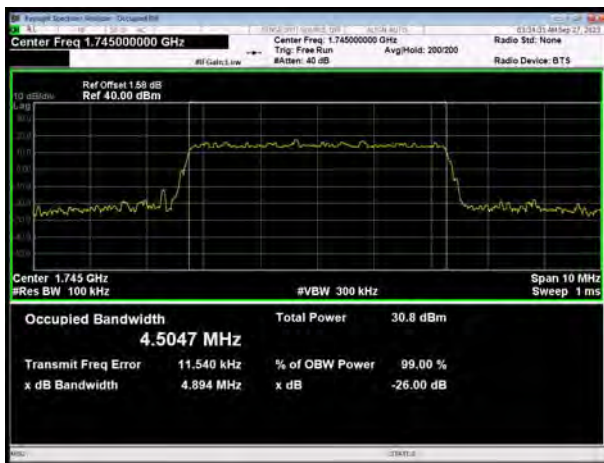

LTE Band 66 64QAM 10MHz CH-Middle



LTE Band 66 64QAM 5MHz CH-High

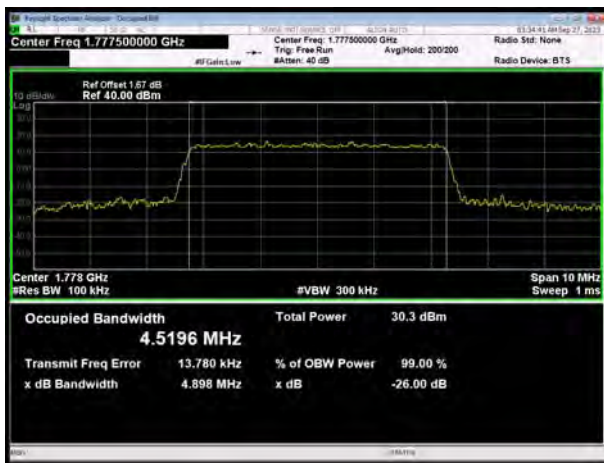

LTE Band 66 64QAM 10MHz CH-High

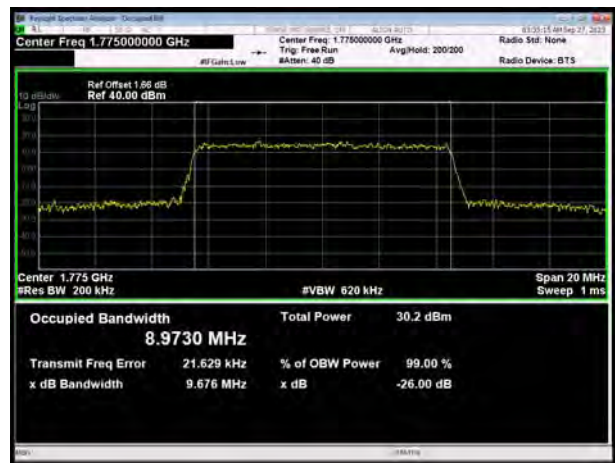

LTE Band 66 64QAM 15MHz CH-Low

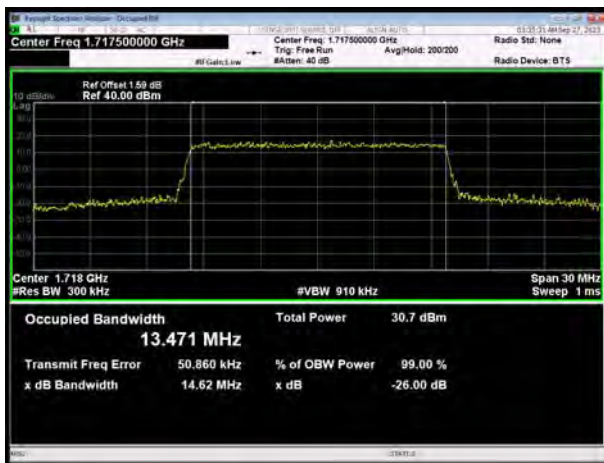

LTE Band 66 64QAM 20MHz CH-Low



LTE Band 66 64QAM 15MHz CH-Middle



LTE Band 66 64QAM 20MHz CH-Middle



LTE Band 66 64QAM 15MHz CH-High

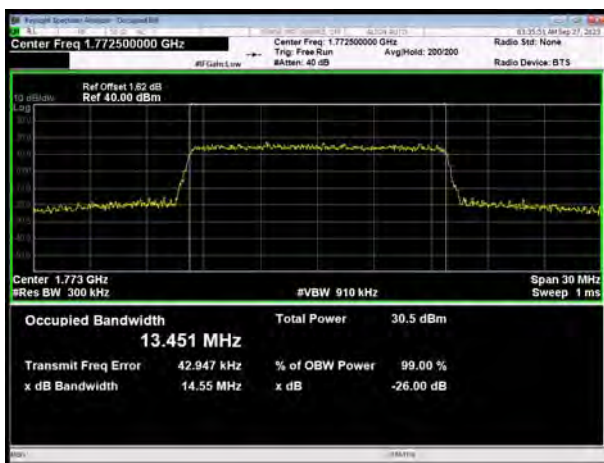

LTE Band 66 64QAM 20MHz CH-High

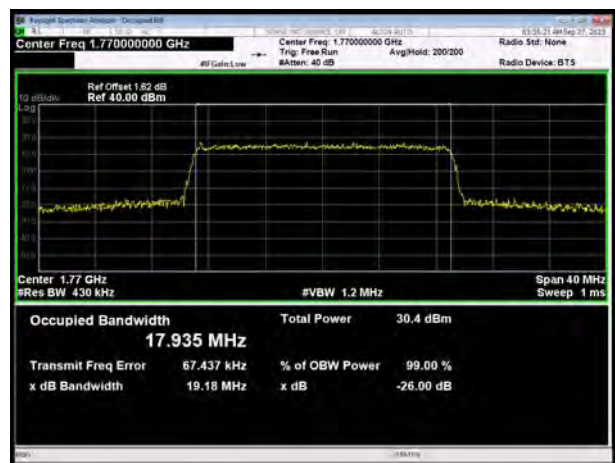

6.3 Band Edge Compliance

All the test traces in the plots shows the test results clearly.

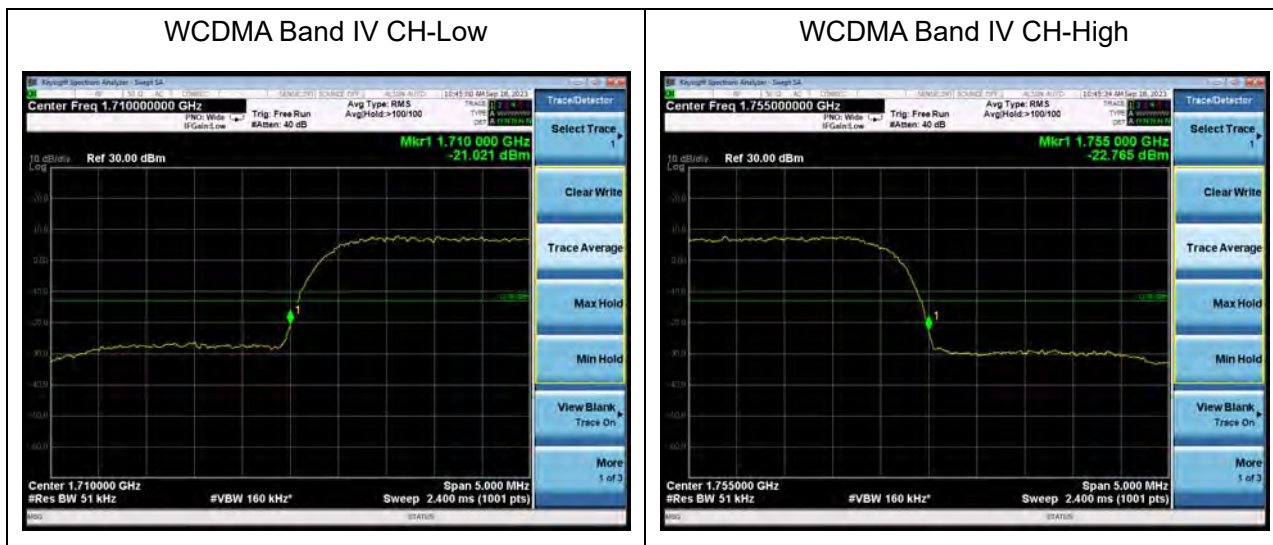

LTE Band 4 QPSK 1.4MHz CH-Low, 1 RB



LTE Band 4 QPSK 1.4MHz CH-High, 1 RB

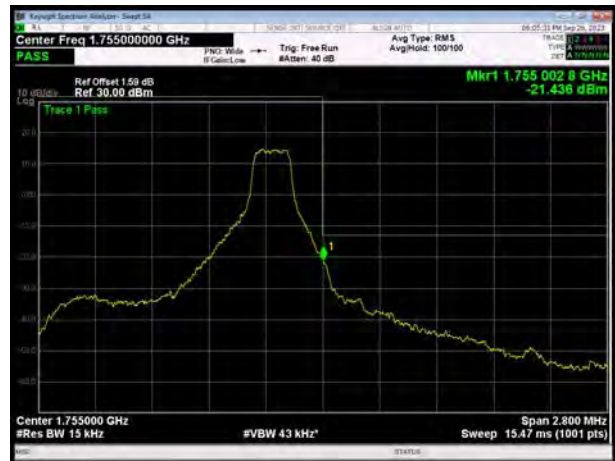

LTE Band 4 QPSK 1.4MHz CH-Low, 100%RB



LTE Band 4 QPSK 1.4MHz CH-High, 100%RB



LTE Band 4 QPSK 3MHz CH-Low, 1 RB

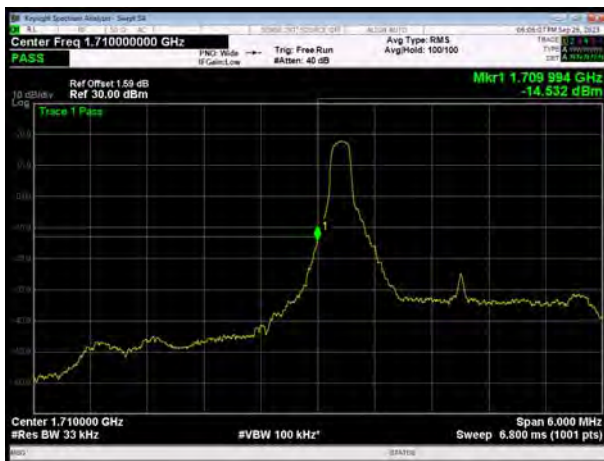

LTE Band 4 QPSK 3MHz CH-High, 1 RB

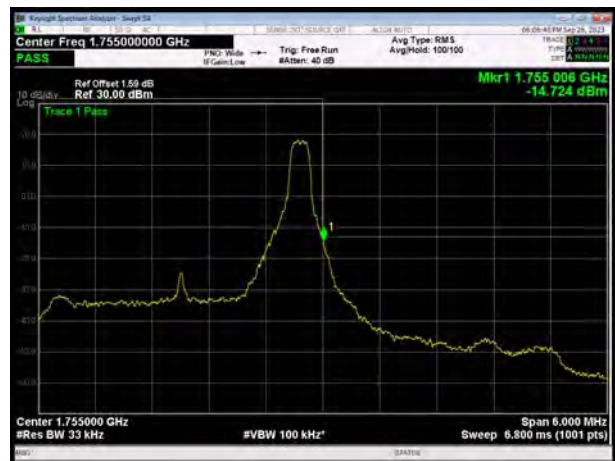

LTE Band 4 QPSK 3MHz CH-Low, 100%RB



LTE Band 4 QPSK 3MHz CH-High, 100%RB



LTE Band 4 QPSK 5MHz CH-Low, 1 RB

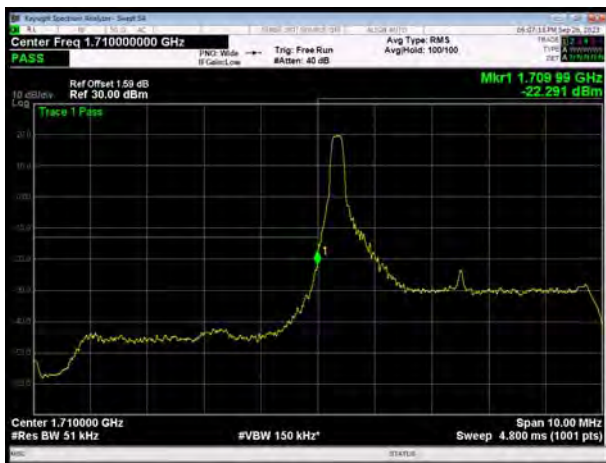

LTE Band 4 QPSK 5MHz CH-High, 1 RB

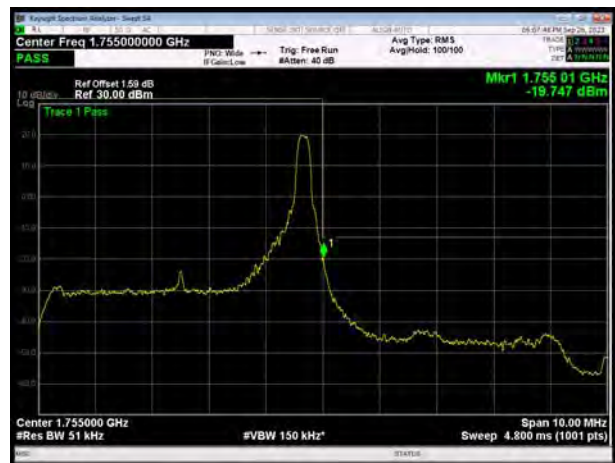

LTE Band 4 QPSK 5MHz CH-Low, 100%RB

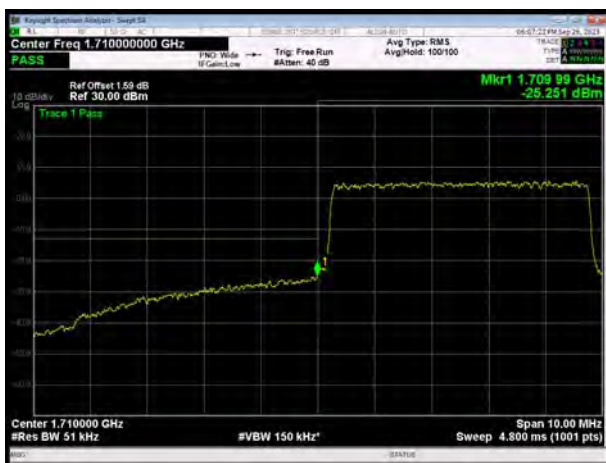

LTE Band 4 QPSK 5MHz CH-High, 100%RB

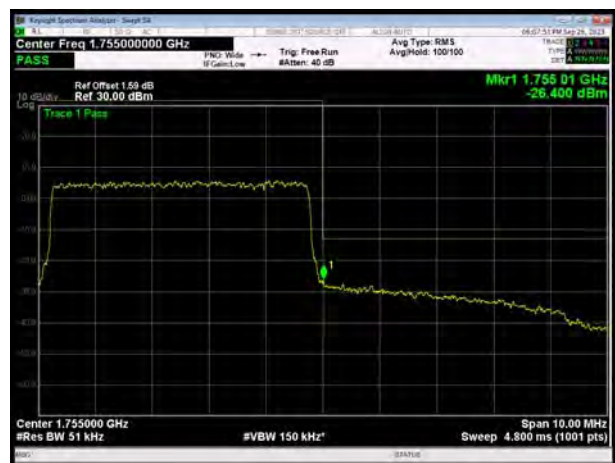

LTE Band 4 QPSK 10MHz CH-Low, 1 RB

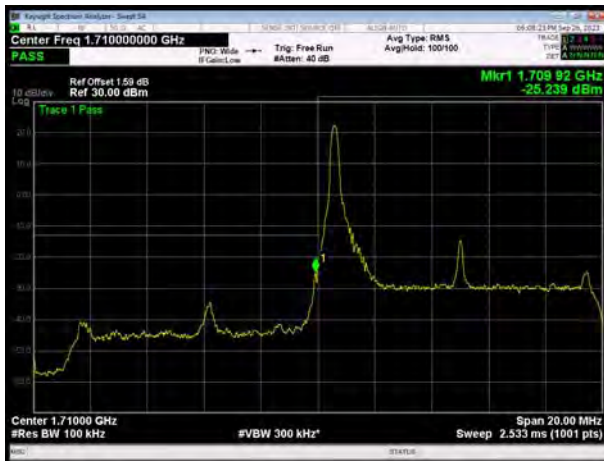

LTE Band 4 QPSK 10MHz CH-High, 1 RB

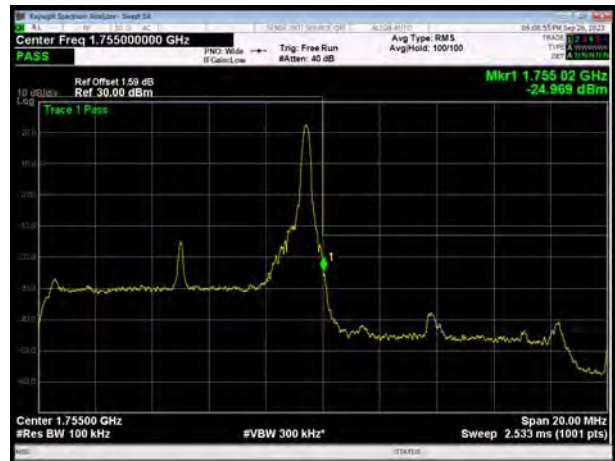

LTE Band 4 QPSK 10MHz CH-Low, 100%RB

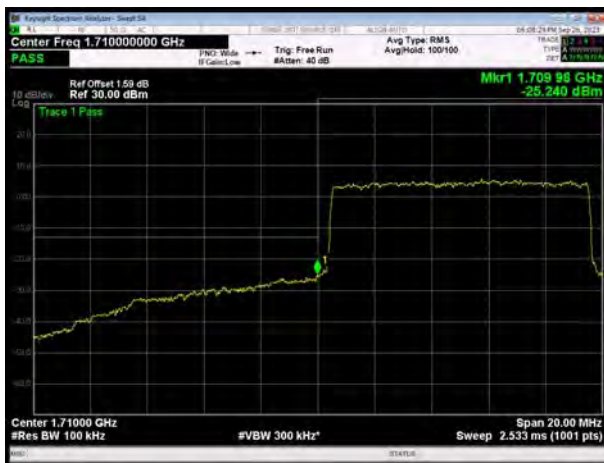

LTE Band 4 QPSK 10MHz CH-High, 100%RB

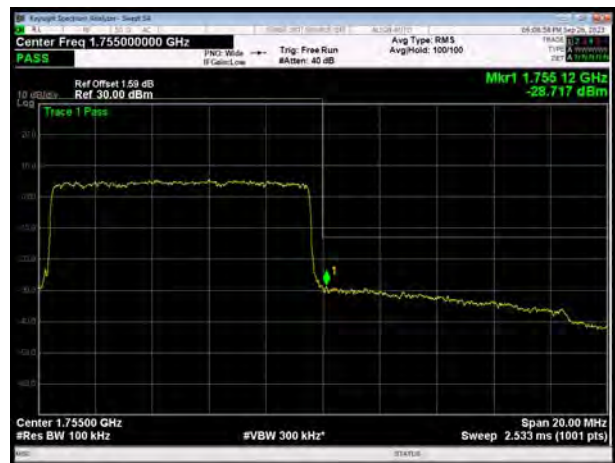

LTE Band 4 QPSK 15MHz CH-Low, 1 RB

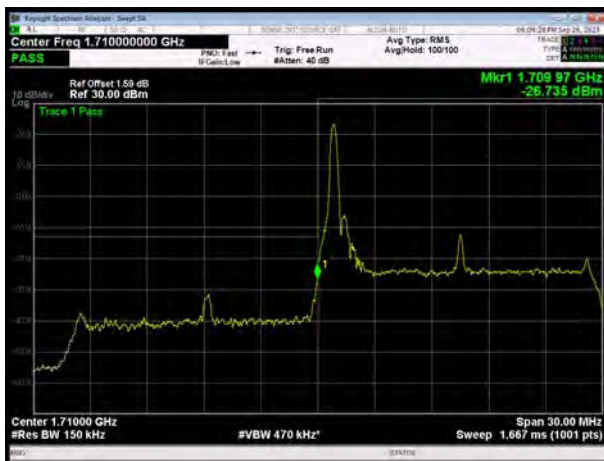

LTE Band 4 QPSK 15MHz CH-High, 1 RB



LTE Band 4 QPSK 15MHz CH-Low, 100%RB



LTE Band 4 QPSK 15MHz CH-High, 100%RB

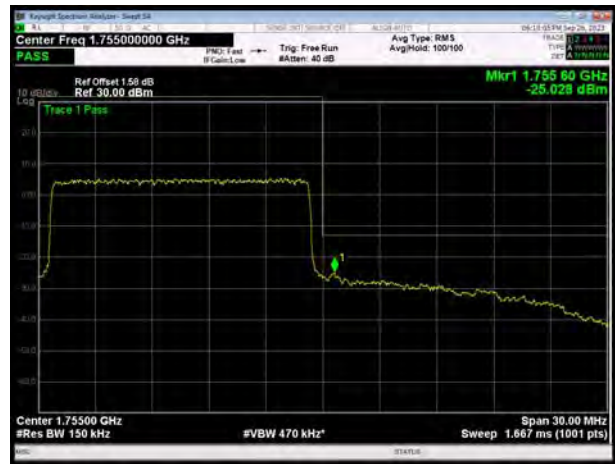

LTE Band 4 QPSK 20MHz CH-Low, 1 RB

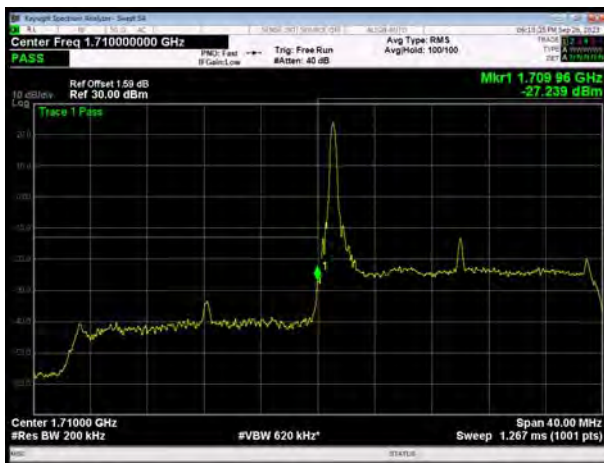

LTE Band 4 QPSK 20MHz CH-High, 1 RB

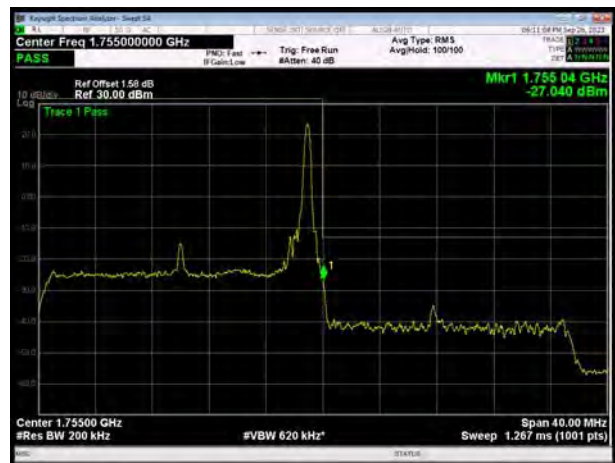

LTE Band 4 QPSK 20MHz CH-Low, 100%RB

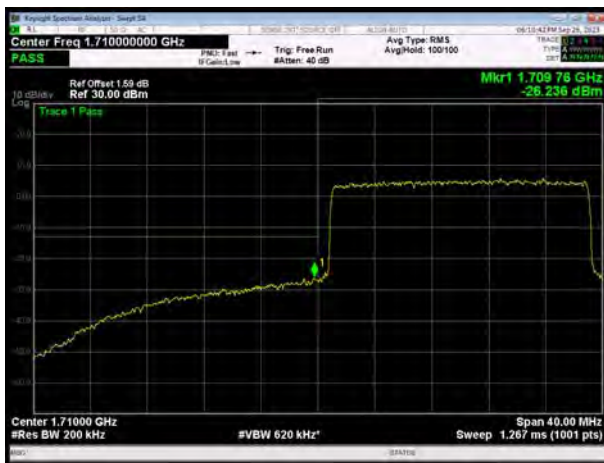

LTE Band 4 QPSK 20MHz CH-High, 100%RB

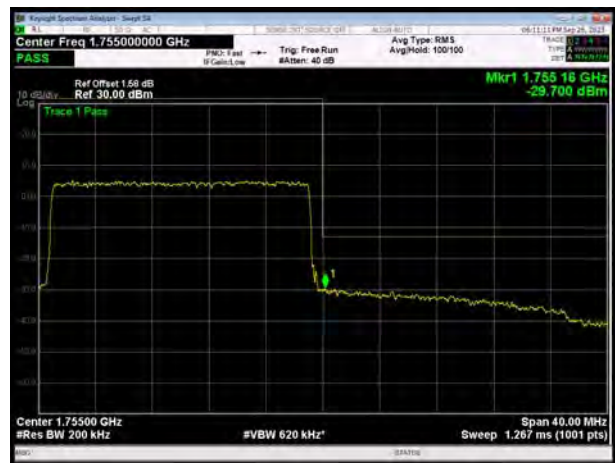

LTE Band 4 16QAM 1.4MHz CH-Low, 1 RB



LTE Band 4 16QAM 1.4MHz CH-High, 1 RB

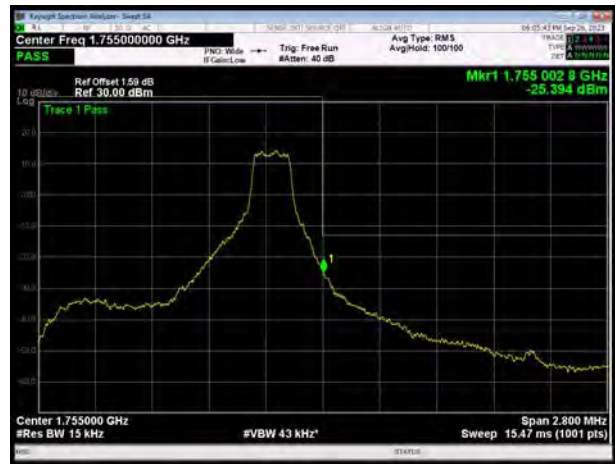

LTE Band 4 16QAM 1.4MHz CH-Low, 100%RB

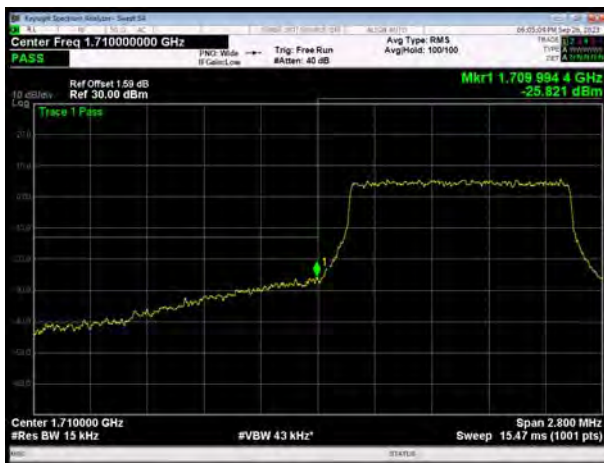

LTE Band 4 16QAM 1.4MHz CH-High, 100%RB



LTE Band 4 16QAM 3MHz CH-Low, 1 RB

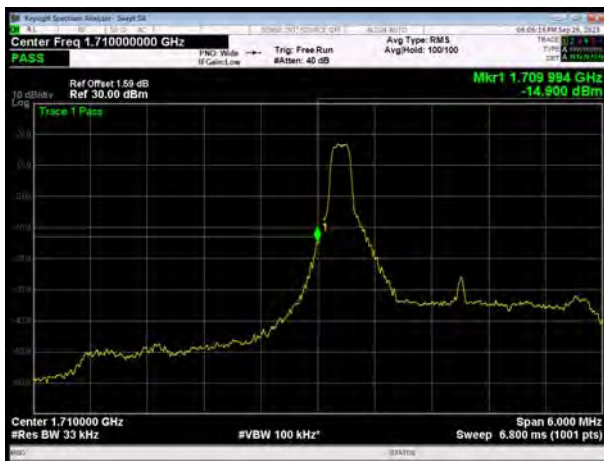

LTE Band 4 16QAM 3MHz CH-High, 1 RB

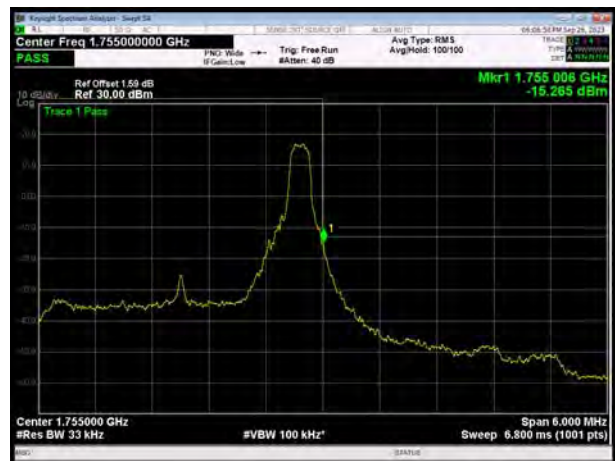

LTE Band 4 16QAM 3MHz CH-Low, 100%RB

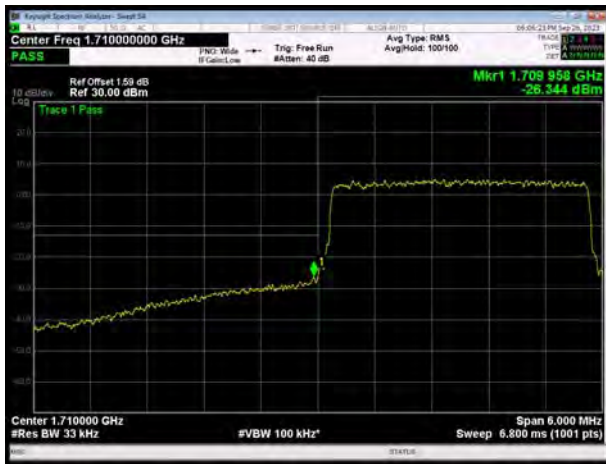

LTE Band 4 16QAM 3MHz CH-High, 100%RB

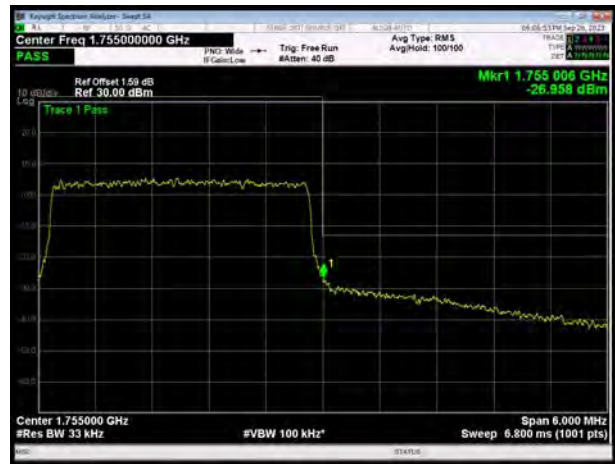

LTE Band 4 16QAM 5MHz CH-Low, 1 RB

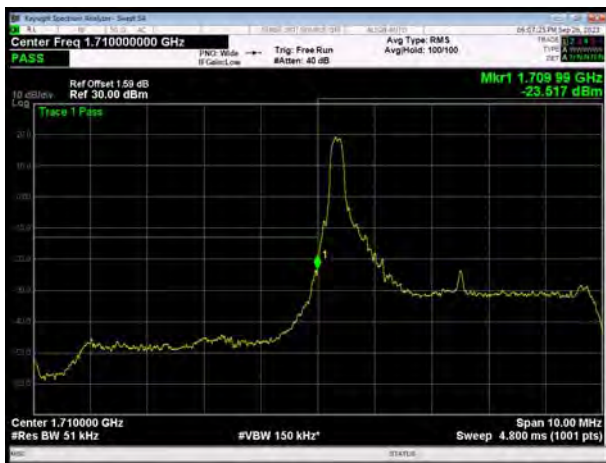

LTE Band 4 16QAM 5MHz CH-High, 1 RB

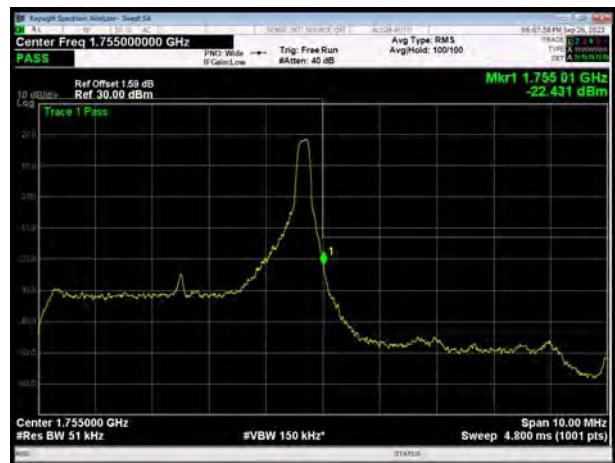

LTE Band 4 16QAM 5MHz CH-Low, 100%RB



LTE Band 4 16QAM 5MHz CH-High, 100%RB



LTE Band 4 16QAM 10MHz CH-Low, 1 RB

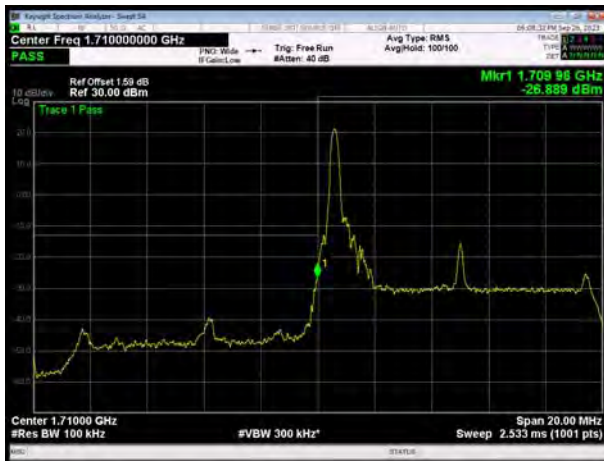

LTE Band 4 16QAM 10MHz CH-High, 1 RB

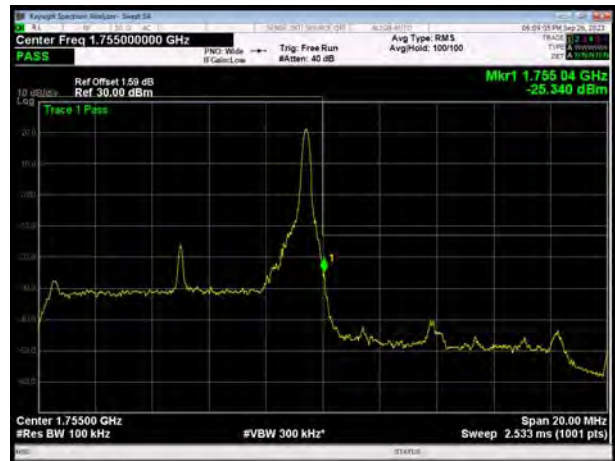

LTE Band 4 16QAM 10MHz CH-Low, 100%RB

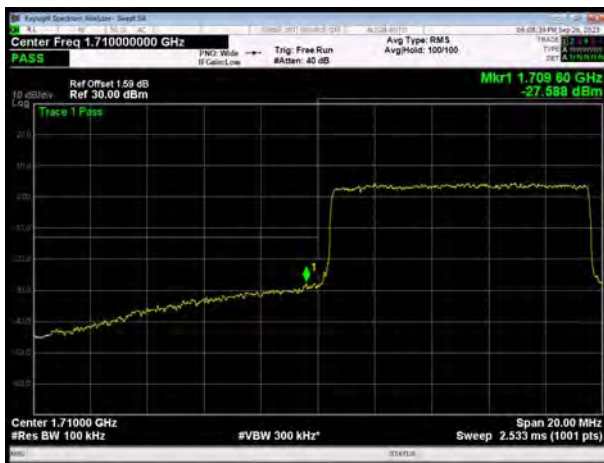

LTE Band 4 16QAM 10MHz CH-High, 100%RB

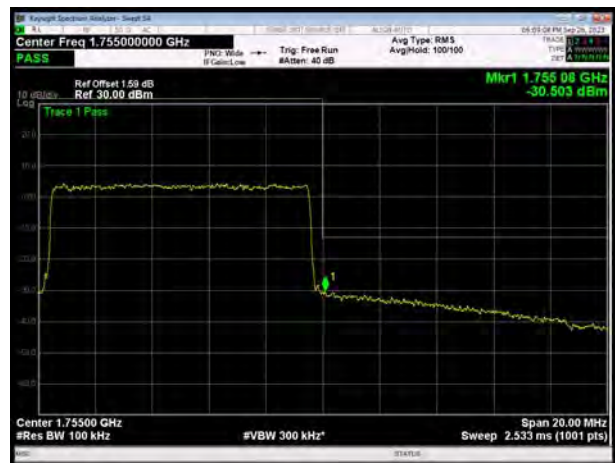

LTE Band 4 16QAM 15MHz CH-Low, 1 RB

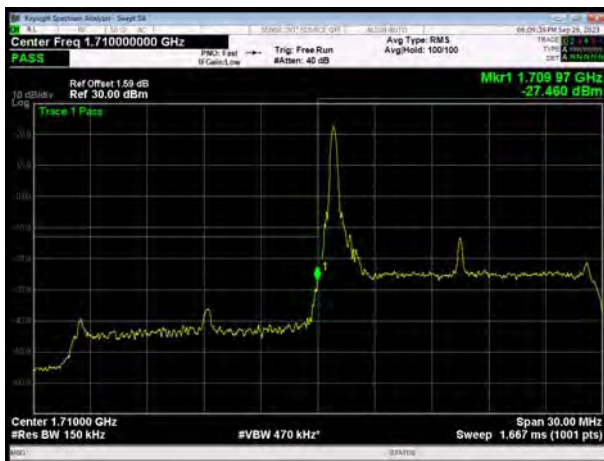

LTE Band 4 16QAM 15MHz CH-High, 1 RB

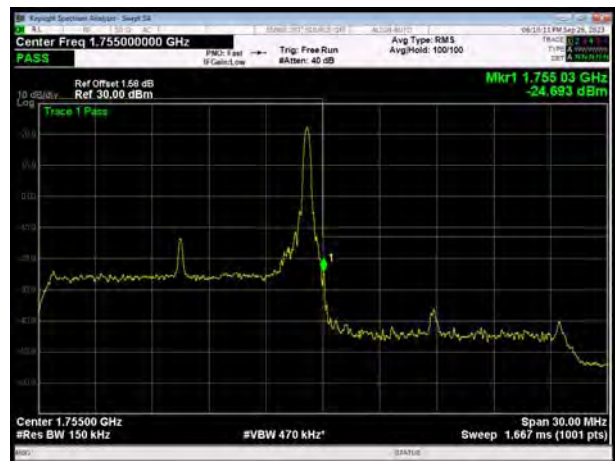

LTE Band 4 16QAM 15MHz CH-Low, 100%RB

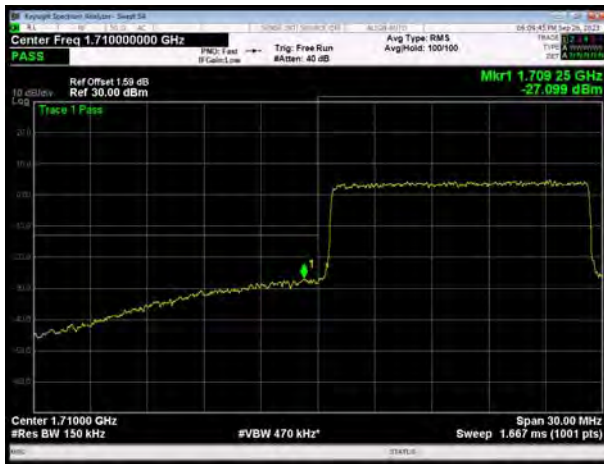

LTE Band 4 16QAM 15MHz CH-High, 100%RB

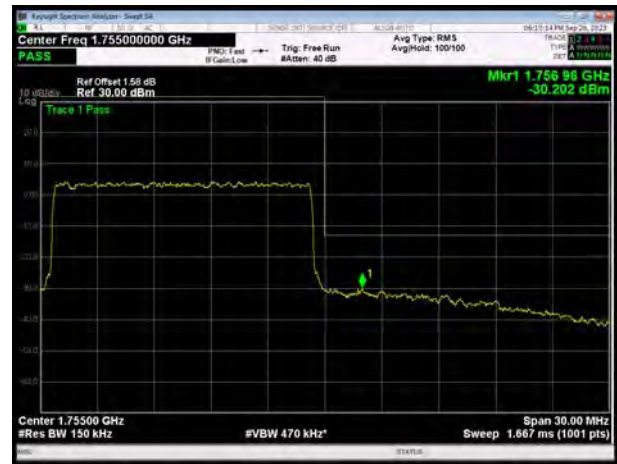

LTE Band 4 16QAM 20MHz CH-Low, 1 RB

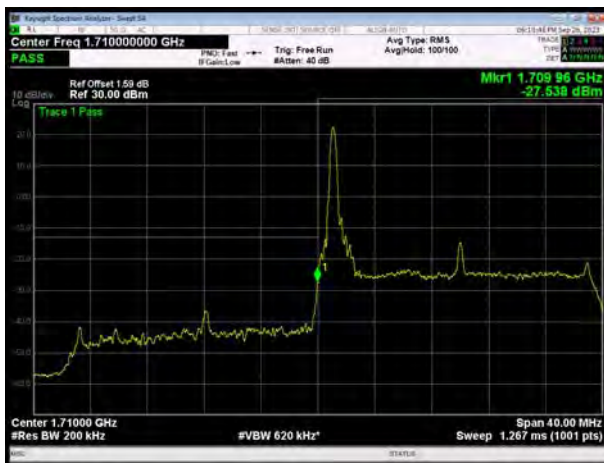

LTE Band 4 16QAM 20MHz CH-High, 1 RB

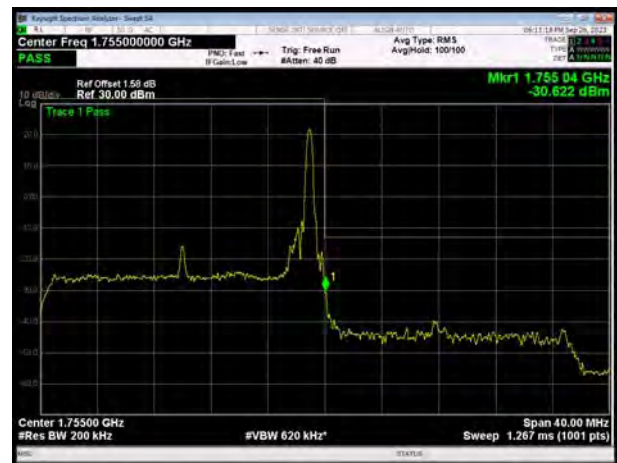

LTE Band 4 16QAM 20MHz CH-Low, 100%RB



LTE Band 4 16QAM 20MHz CH-High, 100%RB

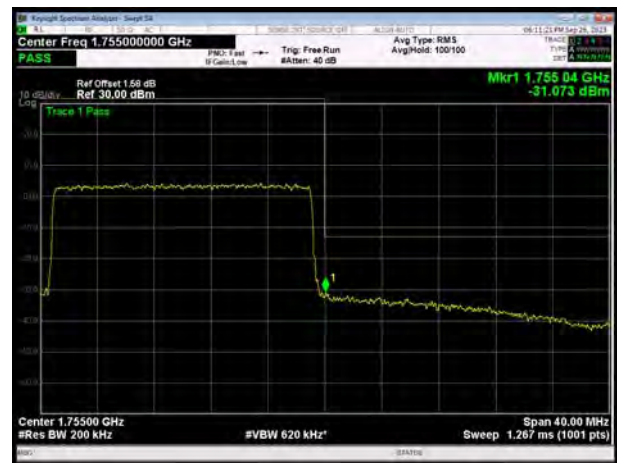

LTE Band 4 64QAM 1.4MHz CH-Low, 1 RB

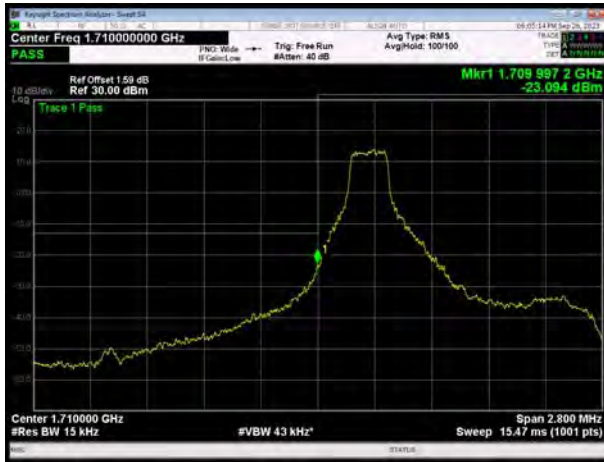

LTE Band 4 64QAM 1.4MHz CH-High, 1 RB

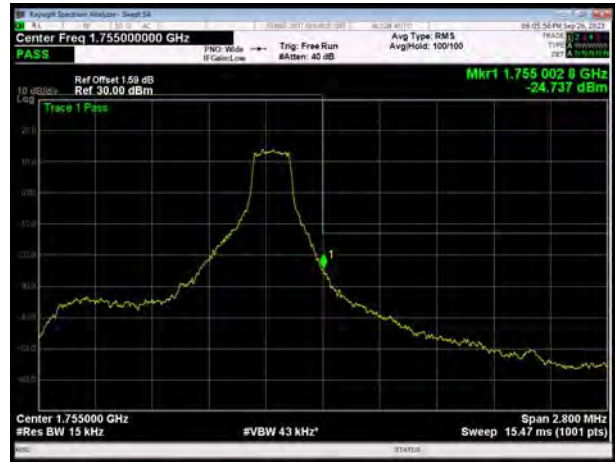

LTE Band 4 64QAM 1.4MHz CH-Low, 100%RB



LTE Band 4 64QAM 1.4MHz CH-High, 100%RB



LTE Band 4 64QAM 3MHz CH-Low, 1 RB

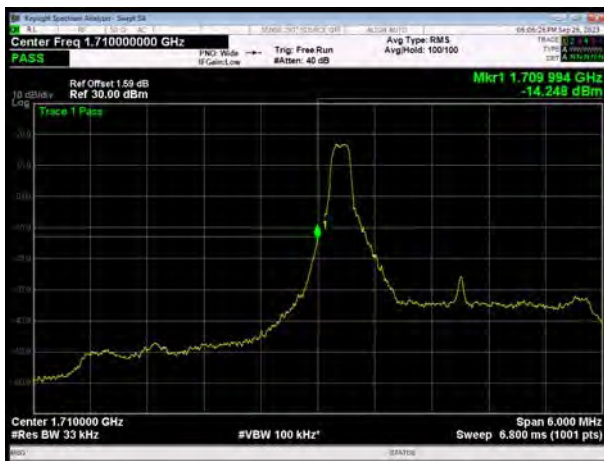

LTE Band 4 64QAM 3MHz CH-High, 1 RB

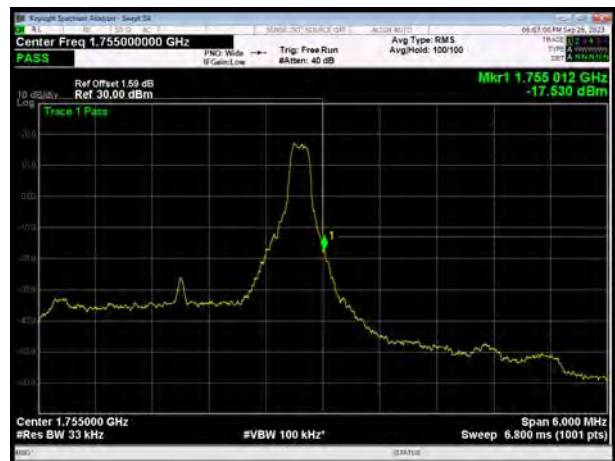

LTE Band 4 64QAM 3MHz CH-Low, 100%RB

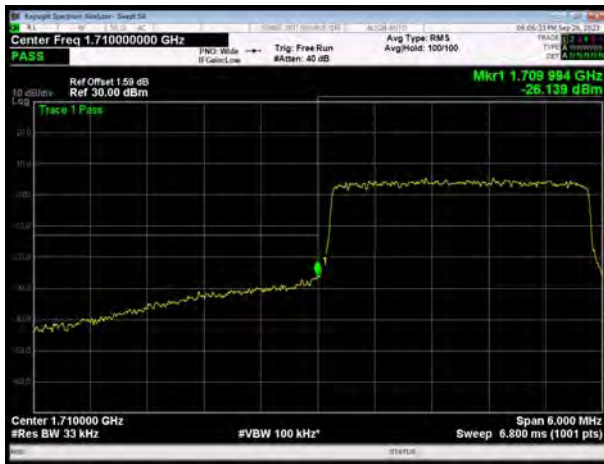

LTE Band 4 64QAM 3MHz CH-High, 100%RB

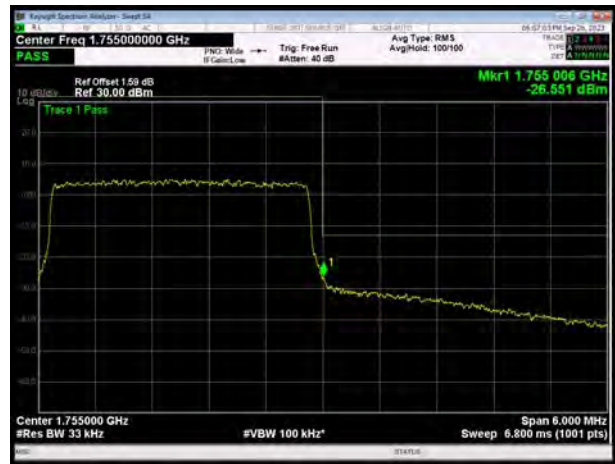

LTE Band 4 64QAM 5MHz CH-Low, 1 RB

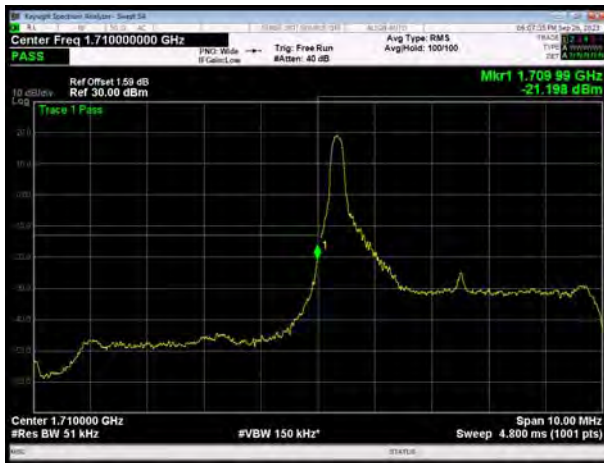

LTE Band 4 64QAM 5MHz CH-High, 1 RB

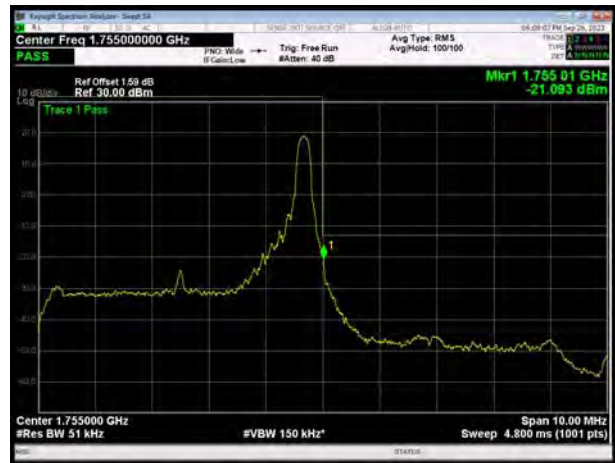

LTE Band 4 64QAM 5MHz CH-Low, 100%RB

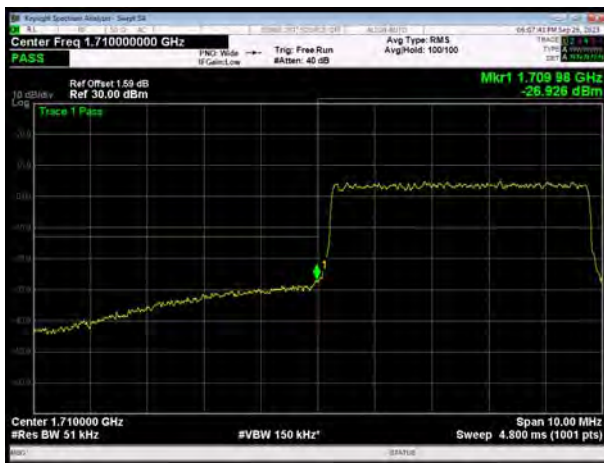

LTE Band 4 64QAM 5MHz CH-High, 100%RB



LTE Band 4 64QAM 10MHz CH-Low, 1 RB

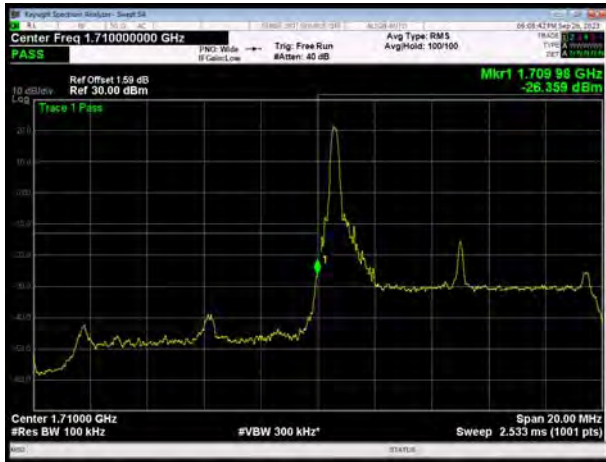

LTE Band 4 64QAM 10MHz CH-High, 1 RB

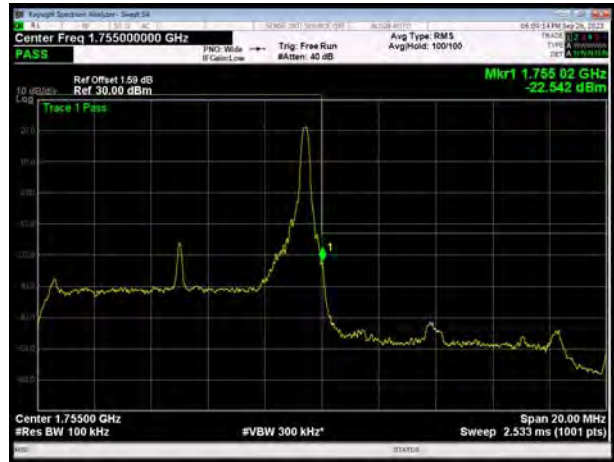

LTE Band 4 64QAM 10MHz CH-Low, 100%RB

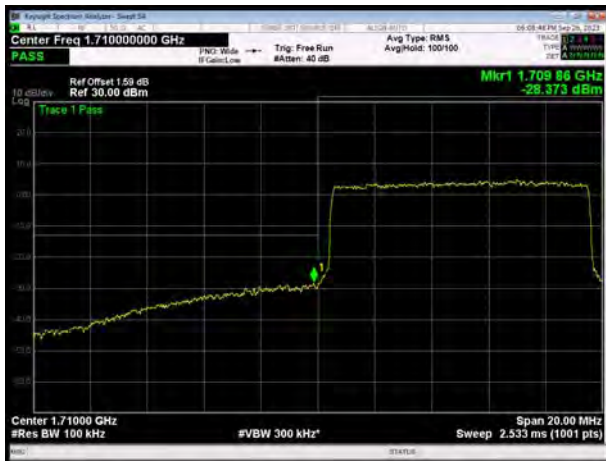

LTE Band 4 64QAM 10MHz CH-High, 100%RB

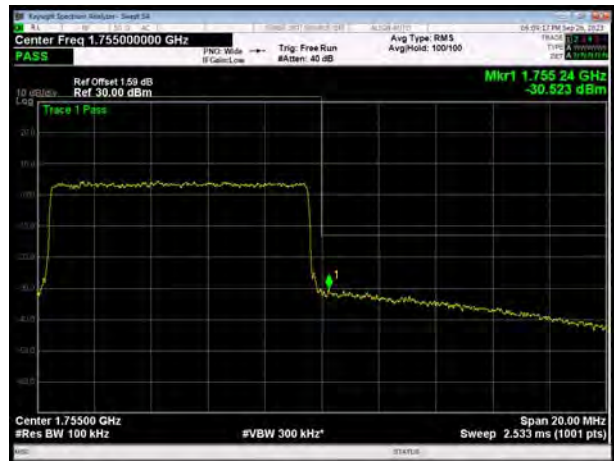

LTE Band 4 64QAM 15MHz CH-Low, 1 RB

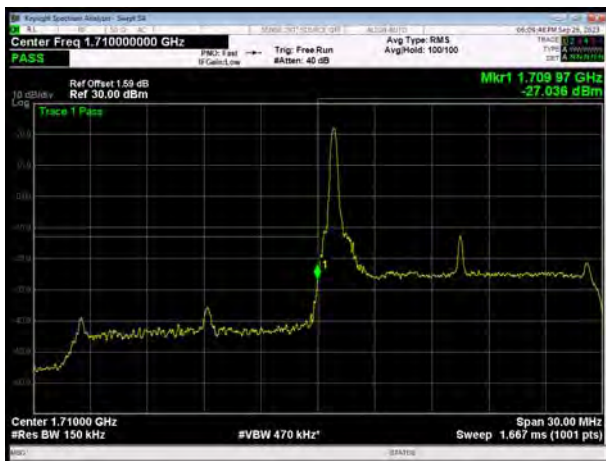

LTE Band 4 64QAM 15MHz CH-High, 1 RB

