



FCC RF Test Report

APPLICANT : Xiaomi Communications Co., Ltd.
EQUIPMENT : Mobile Phone
BRAND NAME : POCO
MODEL NAME : 24069PC21G
FCC ID : 2AFZZPC21G
STANDARD : 47 CFR Part 2, 96
CLASSIFICATION : Citizens Band End User Devices (CBE)
EQUIPMENT TYPE : End User Equipment
TEST DATE(S) : Feb. 25, 2024 ~ Mar. 14, 2024

We, Sporton International Inc. (Kunshan), would like to declare that the tested sample has been evaluated in accordance with the procedures given in ANSI C63.26 and shown compliance with the applicable technical standards.

The test results in this report apply exclusively to the tested model / sample. Without written approval of Sporton International Inc. (Kunshan), the test report shall not be reproduced except in full.

Jason Jia

Approved by: Jason Jia



Sporton International Inc. (Kunshan)

**No. 1098, Pengxi North Road, Kunshan Economic Development Zone Jiangsu Province 215300
People's Republic of China**



Table of Contents

History of this test report..... 3

Summary of Test Result..... 4

1 General Description 5

 1.1 Applicant..... 5

 1.2 Manufacturer 5

 1.3 Feature of Equipment Under Test..... 5

 1.4 Maximum EIRP Power and Emission Designator 6

 1.5 Testing Site..... 6

 1.6 Test Software 6

 1.7 Applied Standards 7

2 Test Configuration of Equipment Under Test 8

 2.1 Test Mode..... 8

 2.2 Connection Diagram of Test System 9

 2.3 Support Unit used in test configuration 9

 2.4 Measurement Results Explanation Example 9

 2.5 Frequency List of Low/Middle/High Channels..... 10

3 Conducted Test Items..... 11

 3.1 Measuring Instruments..... 11

 3.2 Test Setup 11

 3.3 Conducted Output Power 12

 3.4 EIRP 13

 3.5 Occupied Bandwidth 14

 3.6 Conducted Band Edge 15

 3.7 Conducted Spurious Emission 16

 3.8 Frequency Stability..... 17

4 Radiated Test Items 18

 4.1 Measuring Instruments..... 18

 4.2 Test Setup 18

 4.3 Test Result of Radiated Test..... 19

 4.4 Radiated Spurious Emission 20

5 List of Measuring Equipment..... 21

6 Measurement Uncertainty 22

Appendix A. Test Results of Conducted Test

Appendix B. Test Results of Radiated Test

Appendix C. Test Setup Photographs



History of this test report

Report No.	Version	Description	Issued Date
FG420425F	01	Initial issue of report	Mar. 27, 2024



Summary of Test Result

Report Clause	Ref Std. Clause	Test Items	Result (PASS/FAIL)	Remark
3.3	§2.1046	Conducted Output Power	Reporting only	-
-	§96.41	Peak-to-Average Ratio	Not Applicable	Not applicable for End User Devices
3.4	§96.41	Maximum E.I.R.P	Pass	-
		Maximum Power Spectral Density	Not Applicable	Not applicable for End User Devices
3.5	§2.1049 §96.41	Occupied Bandwidth	Reporting only	-
3.6	§2.1051 §96.41	Conducted Band Edge Measurement Adjacent Channel Leakage Ratio	Pass	-
3.7	§2.1051 §96.41	Conducted Spurious Emission	Pass	
3.8	§2.1055	Frequency Stability for Temperature & Voltage	Pass	-
4.4	§2.1051 §96.41	Radiated Spurious Emission	Pass	Under limit 12.56 dB at 10850.00 MHz

Conformity Assessment Condition:
1. The test results (PASS/FAIL) with all measurement uncertainty excluded are presented against the regulation limits or in accordance with the requirements stipulated by the applicant/manufacturer who shall bear all the risks of non-compliance that may potentially occur if measurement uncertainty is taken into account.
2. The measurement uncertainty please refer to each test result in the section "Measurement Uncertainty"
Disclaimer:
The product specifications of the EUT presented in the test report that may affect the test assessments are declared by the manufacturer who shall take full responsibility for the authenticity.



1 General Description

1.1 Applicant

Xiaomi Communications Co., Ltd.

#019, 9th Floor, Building 6, 33 Xi'erqi Middle Road, Haidian District, Beijing, China, 100085

1.2 Manufacturer

Xiaomi Communications Co., Ltd.

#019, 9th Floor, Building 6, 33 Xi'erqi Middle Road, Haidian District, Beijing, China, 100085

1.3 Feature of Equipment Under Test

Product Feature	
Equipment	Mobile Phone
Brand Name	POCO
Model Name	24069PC21G
FCC ID	2AFZZPC21G
Tx Frequency	LTE Band 48: 3550 MHz ~ 3700 MHz
Rx Frequency	LTE Band 48: 3550 MHz ~ 3700 MHz
Bandwidth	5MHz / 10MHz / 15MHz / 20MHz
Maximum Output Power to Antenna	<Ant. 1>: LTE Band 48: 23.13 dBm <Ant. 6>: LTE Band 48: 23.02 dBm <Ant. 7>: LTE Band 48: 22.94 dBm <Ant. 8>: LTE Band 48: 20.52 dBm
Antenna Gain	<Ant. 1>: LTE Band 48: -3.10 dBi <Ant. 6>: LTE Band 48: -0.30 dBi <Ant. 7>: LTE Band 48: -0.70 dBi <Ant. 8>: LTE Band 48: -0.30 dBi
Type of Modulation	QPSK / 16QAM / 64QAM / 256QAM
IMEI Code	Conducted: 861593070020849/861593070020856 Radiation: 861593070015641/861593070015658
HW Version	1351N16T
SW Version	Xiaomi HyperOS 1.0
EUT Stage	Identical Prototype

Remark:

1. The above EUT's information was declared by manufacturer. Please refer to the specifications or user's manual for more detailed description.
2. The maximum EIRP is calculated from max output power and antenna gain, only the maximum EIRP of Ant. 6 is shown in the report.
3. The device supports B48(1T4R) SRS resources on ant.1/6/7/8, only the test data of worst ant.1 is showed in the report according to the maximum power.
4. LTE Band48 channels were set NS_27 to reduce power.

1.4 Maximum EIRP Power and Emission Designator

LTE Band 48		QPSK		16QAM/64QAM/256QAM	
BW (MHz)	Frequency Range (MHz)	Maximum EIRP(W)	Emission Designator (99%OBW)	Maximum EIRP(W)	Emission Designator (99%OBW)
5	3552.5~3697.5	0.1832	4M53G7D	0.1871	4M48W7D
10	3555~3695	0.1841	8M99G7D	0.1849	9M03W7D
15	3557.5~3692.5	0.1807	13M5G7D	0.1824	13M4W7D
20	3560~3690	0.1795	17M9G7D	0.1807	18M0W7D

Note: All modulations have been tested, only the worst test results of PSK & QAM are shown in the report.

1.5 Testing Site

Sporton International Inc. (Kunshan) is accredited to ISO/IEC 17025:2017 by American Association for Laboratory Accreditation with Certificate Number 5145.02.

Test Firm	Sporton International Inc. (Kunshan)		
Test Site Location	No. 1098, Pengxi North Road, Kunshan Economic Development Zone Jiangsu Province 215300 People's Republic of China TEL : +86-512-57900158		
Test Site No.	Sporton Site No.	FCC Designation No.	FCC Test Firm Registration No.
	03CH04-KS TH01-KS	CN1257	314309

1.6 Test Software

Item	Site	Manufacture	Name	Version
1.	TH01-KS	SPORTON	FCC LTE_Ver2.0 Auto_china_210503	2.0
2.	03CH04-KS	AUDIX	E3	210616



1.7 Applied Standards

According to the specifications of the manufacturer, the EUT must comply with the requirements of the following standards:

- ♦ ANSI C63.26-2015
- ♦ 47 CFR Part 2, 96
- ♦ FCC KDB 971168 D01 Power Meas. License Digital Systems v03r01
- ♦ FCC KDB 940660 D01 Part 96 CBRS v03
- ♦ FCC KDB 412172 D01 Determining ERP and EIRP v01r01

Remark:

1. All test items were verified and recorded according to the standards and without any deviation during the test.
2. This EUT has also been tested and complied with the requirements of FCC Part 15, Subpart B, recorded in a separate test report.



2 Test Configuration of Equipment Under Test

2.1 Test Mode

Antenna port conducted and radiated test items listed below are performed according to KDB 971168 D01 Power Meas. License Digital Systems v03r01 with maximum output power.

For radiated measurement, pre-scanned in three orthogonal panels, X, Y, Z. The worst cases (X plane) were recorded in this report.

Test Items	Band	Bandwidth (MHz)						Modulation				RB #			Test Channel		
		1.4	3	5	10	15	20	QPSK	16QAM	64QAM	256QAM	1	Half	Full	L	M	H
Max. Output Power	48	-	-	v	v	v	v	v	v	v	v	v	v	v	v	v	v
26dB and 99% Bandwidth	48	-	-	v	v	v	v	v	v					v		v	
Conducted Band Edge	48	-	-	v	v	v	v	v	v	v	v	v		v	v	v	v
Conducted Spurious Emission	48	-	-	v	v	v	v	v					v			v	v
ACLR	48	-	-	v	v	v	v	v	v	v	v	v		v	v	v	v
E.I.R.P.	48	-	-	v	v	v	v	v	v	v	v	v	v	v	v	v	v
Frequency Stability	48	-	-	v				v					v				v
Radiated Spurious Emission	48	Worst Case														v	
Remark	<ol style="list-style-type: none"> The mark "v" means that this configuration is chosen for testing The mark "-" means that this bandwidth is not supported. The device is investigated from 30MHz to 10 times of fundamental signal for radiated spurious emission test under different RB size/offset and modulations in exploratory test. Subsequently, only the worst case emissions are reported. All test items are based on engineering evaluation. 																

2.2 Connection Diagram of Test System

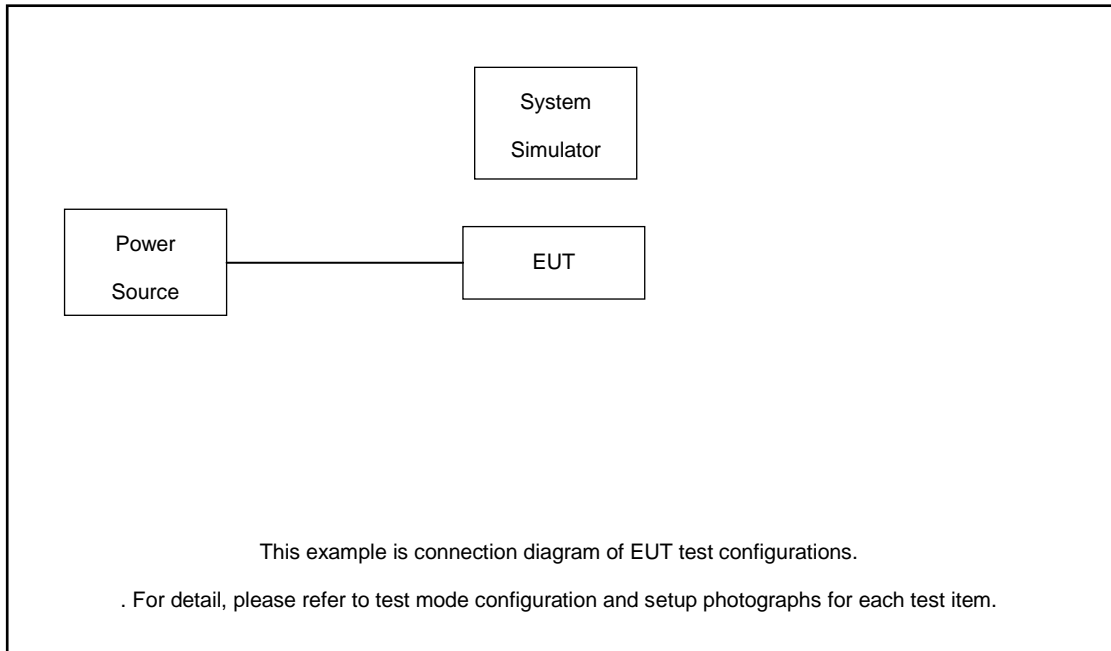

2.3 Support Unit used in test configuration

Item	Equipment	Trade Name	Model No.	FCC ID	Data Cable	Power Cord
1.	Power Supply	GWINSTEK	PSS-2002	N/A	N/A	Unshielded, 1.8 m
2.	LTE Base Station	Anritsu	MT8821C	N/A	N/A	Unshielded, 1.8 m

2.4 Measurement Results Explanation Example

For all conducted test items:

The offset level is set in the spectrum analyzer to compensate the RF cable loss between EUT conducted output port and spectrum analyzer. With the offset compensation, the spectrum analyzer reading level is exactly the EUT RF output level.

The spectrum analyzer offset is derived from RF cable loss.

$$\text{Offset} = \text{RF cable loss.}$$

Following shows an offset computation example with cable loss 7.0 dB.

Example :

$$\begin{aligned} \text{Offset(dB)} &= \text{RF cable loss(dB)}. \\ &= 7.0 \text{ (dB)} \end{aligned}$$



2.5 Frequency List of Low/Middle/High Channels

LTE Band 48 Channel and Frequency List				
BW [MHz]	Channel/Frequency(MHz)	Lowest	Middle	Highest
20	Channel	55340	55990	56640
	Frequency	3560.0	3625.0	3690.0
15	Channel	55315	55990	56665
	Frequency	3557.5	3625.0	3692.5
10	Channel	55290	55990	56690
	Frequency	3555.0	3625.0	3695.0
5	Channel	55265	55990	56715
	Frequency	3552.5	3625.0	3697.5

3 Conducted Test Items

3.1 Measuring Instruments

See list of measuring instruments of this test report.

3.2 Test Setup

3.2.1 Conducted Output Power / ACLR



3.2.2 26dB & 99% Occupied Bandwidth, Conducted Band-Edge and Conducted Spurious Emission

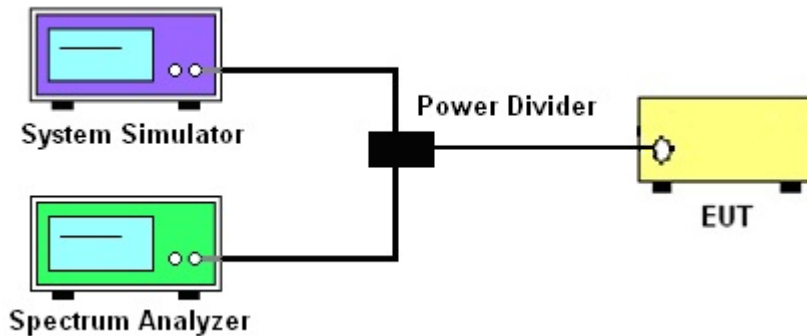

3.2.3 Frequency Stability

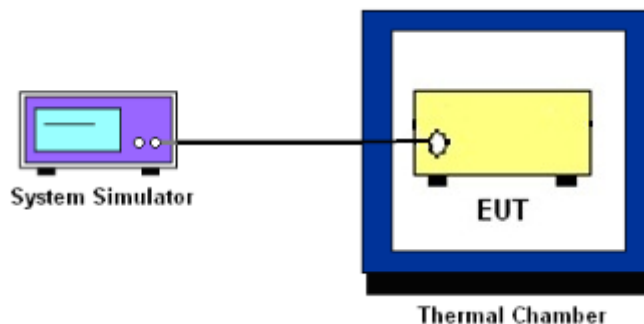

3.2.4 Test Result of Conducted Test

Please refer to Appendix A.



3.3 Conducted Output Power

3.3.1 Description of the Conducted Output Power Measurement

A system simulator was used to establish communication with the EUT. Its parameters were set to force the EUT transmitting at maximum output power. The measured power in the radio frequency on the transmitter output terminals shall be reported.

3.3.2 Test Procedures

1. The transmitter output port was connected to the system simulator.
2. Set EUT at maximum power through the system simulator.
3. Select lowest, middle, and highest channels for each band and different modulation.
4. Measure and record the power level from the system simulator.

3.4 EIRP

3.4.1 Description of the EIRP Measurement

EIRP limits for CBRS equipment as below table:

Device		Maximum EIRP (dBm/10 MHz)	Maximum PSD (dBm/MHz)
Applied	End User Device	23	n/a
<input type="checkbox"/>	Category A CBSD	30	20
<input type="checkbox"/>	Category B CBSD	47	37

Remark: The worst case EIRP shown in this section is found with LTE operating only using 1RB. As such, the EIRP/10MHz and full channel EIRP values will be identical since 1RB is fully contained within all available channel bandwidths for LTE Band 48 (i.e. 5, 10, 15, 20MHz)

3.4.2 Test Procedures for EIRP

1. Establishing a communications link with the call box (Base station) to measure the Maximum conducted power, the parameters were set to force the EUT transmitting at maximum output power level. Use the average power measurement function to measure total channel power of each channel bandwidth (per ANSI C63.26-2015 Section 5.2.1)
2. Determining ERP and/or EIRP from conducted RF output power measurements (Per ANSI C63.26-2015 Section 5.2.5.5)
 - EIRP = $P_T + G_T - L_C$, ERP = EIRP -2.15, where
 - P_T = transmitter output power in dBm
 - G_T = gain of the transmitting antenna in dBi
 - L_C = signal attenuation in the connecting cable between the transmitter and antenna in dB



3.5 Occupied Bandwidth

3.5.1 Description of Occupied Bandwidth Measurement

The occupied bandwidth is the width of a frequency band such that, below the lower and above the upper frequency limits, the mean powers emitted are each equal to a specified percentage 0.5% of the total mean transmitted power.

The 26 dB emission bandwidth is defined as the frequency range between two points, one above and one below the carrier frequency, at which the spectral density of the emission is attenuated 26 dB below the maximum in-band spectral density of the modulated signal. Spectral density (power per unit bandwidth) is to be measured with a detector of resolution bandwidth equal to approximately 1.0% of the emission bandwidth.

3.5.2 Test Procedures

The testing follows ANSI C63.26-2015 Section 5.4.3 (26dB) and Section 5.4.4 (99OB)

1. The EUT was connected to spectrum analyzer and system simulator via a power divider.
2. The spectrum analyzer center frequency is set to the nominal EUT channel center frequency. The span range for the spectrum analyzer shall be between two and five times the anticipated OBW.
3. The nominal resolution bandwidth (RBW) shall be in the range of 1 to 5 % of the anticipated OBW, and the VBW shall be at least 3 times the RBW.
4. Set the detection mode to peak, and the trace mode to max hold.
5. Determine the reference value: Set the EUT to transmit a modulated signal. Allow the trace to stabilize. Set the spectrum analyzer marker to the highest level of the displayed trace.
(this is the reference value)
6. Determine the “-26 dB down amplitude” as equal to (Reference Value – X).
7. Place two markers, one at the lowest and the other at the highest frequency of the envelope of the spectral display such that each marker is at or slightly below the “-X dB down amplitude” determined in step 6. If a marker is below this “-X dB down amplitude” value it shall be placed as close as possible to this value. The OBW is the positive frequency difference between the two markers.
8. Use the 99 % power bandwidth function of the spectrum analyzer and report the measured bandwidth.

3.6 Conducted Band Edge

3.6.1 Description of Conducted Band Edge Measurement

Part 96.41 (e) (1) (i)

For CBSD the emission limits outside the fundamental are as follows:

Within 0 MHz to 10 MHz above and below the assigned channel ≤ -13 dBm/MHz

Greater than 10 MHz above and below the assigned channel ≤ -25 dBm/MHz

Part 96.41 (e) (1) (ii)

For End User Devices the emission limits outside the fundamental are as follows:

Within 0 MHz to B MHz above and below the assigned channel ≤ -13 dBm/MHz

Greater than B MHz above and below the assigned channel ≤ -25 dBm/MHz

where B is the bandwidth in megahertz of the assigned channel or multiple contiguous channels of the End User Device.

Notwithstanding the emission limits in this paragraph, the Adjacent Channel Leakage Ratio for End User Devices shall be at least 30 dB.

Part 96.41 (e) (2)

For CBSDs and End User Devices, the conducted power of emissions below 3540 MHz or above 3710 MHz shall not exceed -25 dBm/MHz, and the conducted power of emissions below 3530 MHz or above 3720 MHz shall not exceed -40 dBm/MHz

3.6.2 Test Procedures

The testing follows FCC KDB 971168 D01 v03r01 Section 6.1.

1. The EUT was connected to spectrum analyzer and system simulator via a power divider.
2. The band edges of low and high channels for the highest RF powers were measured.
3. Set RBW $\geq 1\%$ EBW in the 1MHz band immediately outside and adjacent to the band edge.
4. Beyond the 1 MHz band from the band edge, RBW=1MHz was used or a narrower RBW was used and the measured power was integrated over the full required measurement bandwidth of 1 MHz.
5. Offset has included the duty factor for LTE Band 48. Duty factor $=10 \log (1/x)$, where x is the measured duty cycle.
6. Set spectrum analyzer with RMS detector.
7. The RF fundamental frequency should be excluded against the limit line in the operating frequency band.



3.7 Conducted Spurious Emission

3.7.1 Description of Conducted Spurious Emission Measurement

96.41 (e)(2)

The conducted power of any emissions below 3530 MHz or above 3720 MHz shall not exceed -40dBm/MHz .

3.7.2 Test Procedures

The testing follows FCC KDB 971168 D01 v03r01 Section 6.1.

1. The EUT was connected to spectrum analyzer and system simulator via a power divider.
2. The RF output of EUT was connected to the spectrum analyzer by RF cable and attenuator. The path loss was compensated to the results for each measurement.
3. The middle channel for the highest RF power within the transmitting frequency was measured.
4. The conducted spurious emission for the whole frequency range was taken.
5. Make the measurement with the spectrum analyzer's RBW = 1MHz, VBW = 3MHz.
6. Set spectrum analyzer with RMS detector.
7. Taking the record of maximum spurious emission.
8. The RF fundamental frequency should be excluded against the limit line in the operating frequency band.
9. The limit line is -40dBm/MHz .



3.8 Frequency Stability

3.8.1 Description of Frequency Stability Measurement

The frequency stability shall be measured by variation of ambient temperature and variation of primary supply voltage to ensure that the fundamental emission stays within the authorized frequency block.

3.8.2 Test Procedures for Temperature Variation

The testing follows FCC KDB 971168 D01 v03r01 Section 9.0.

1. The EUT was set up in the thermal chamber and connected with the system simulator.
2. With power OFF, the temperature was decreased to -30°C and the EUT was stabilized before testing. Power was applied and the maximum change in frequency was recorded within one minute.
3. With power OFF, the temperature was raised in 10°C step up to 50°C . The EUT was stabilized at each step for at least half an hour. Power was applied and the maximum frequency change was recorded within one minute.

3.8.3 Test Procedures for Voltage Variation

The testing follows FCC KDB 971168 D01 v03r01 Section 9.0.

1. The EUT was placed in a temperature chamber at $25\pm 5^{\circ}\text{C}$ and connected with the system simulator.
2. The power supply voltage to the EUT was varied from 85% to 115% of the nominal value measured at the input to the EUT.
3. The variation in frequency was measured for the worst case.

4 Radiated Test Items

4.1 Measuring Instruments

See list of measuring instruments of this test report.

4.2 Test Setup

4.2.1 For radiated test below 30MHz

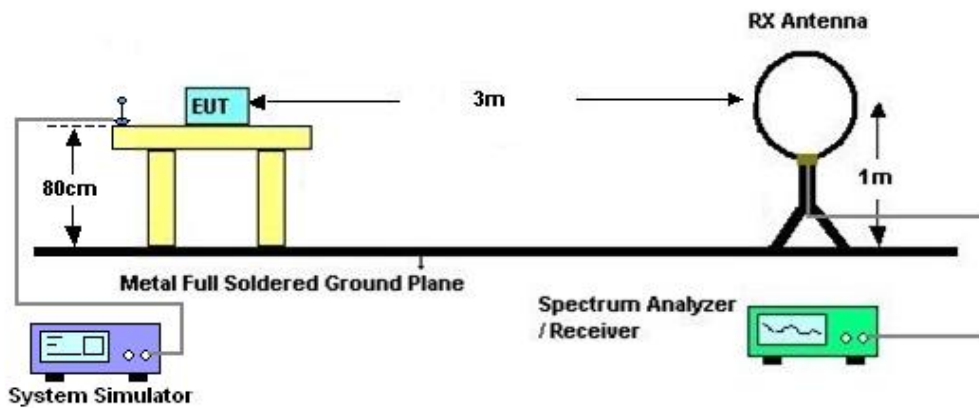

4.2.2 For radiated test from 30MHz to 1GHz

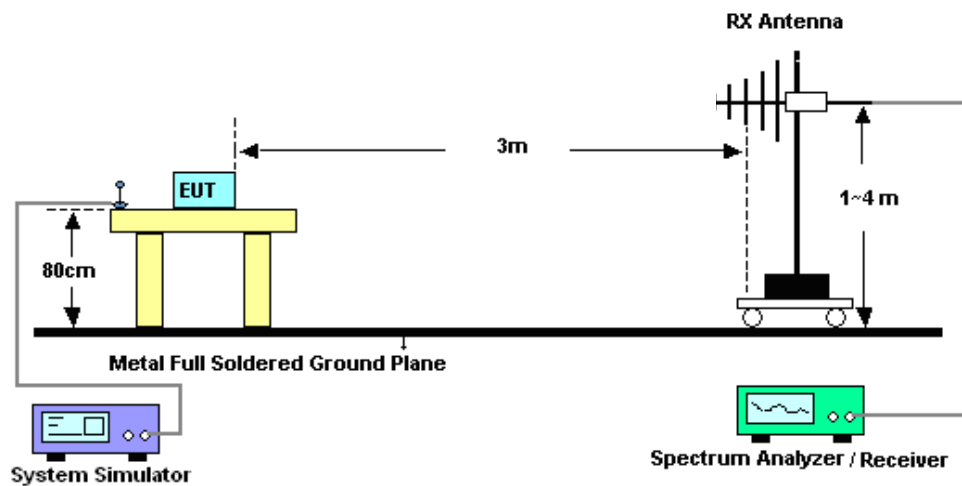

4.2.3 For radiated test above 1GHz

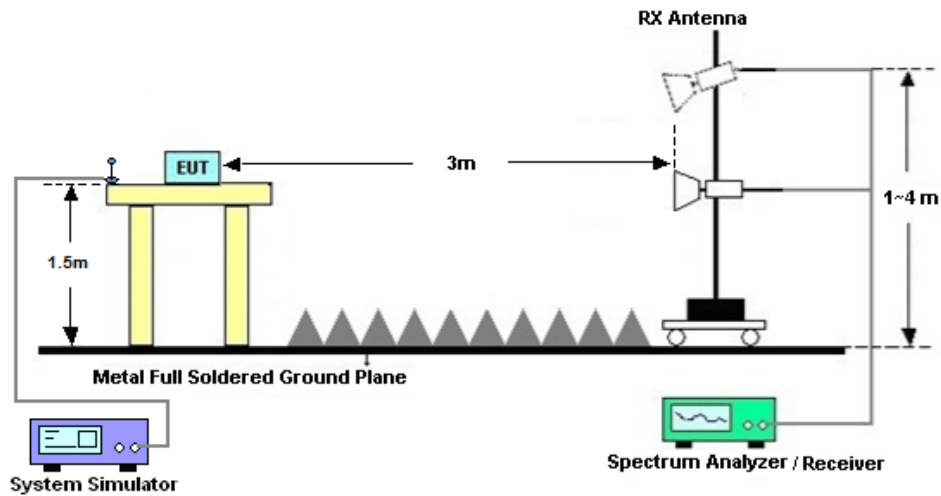

4.3 Test Result of Radiated Test

The low frequency, which started from 9 kHz to 30MHz, was pre-scanned and the result which was 20dB lower than the limit line was not reported.

Please refer to Appendix B.



4.4 Radiated Spurious Emission

4.4.1 Description of Radiated Spurious Emission Measurement

The radiated spurious emission was measured by substitution method according to ANSI C63.26-2015. The power of any emission outside of the authorized operating frequency ranges must be attenuated below the transmitter power (P) by a factor of at least -40dBm / MHz. The spectrum is scanned from 30 MHz up to a frequency including its 10th harmonic.

4.4.2 Test Procedures

1. The EUT was placed on a turntable with 0.8 meter height for frequency below 1GHz and 1.5 meter height for frequency above 1GHz respectively above ground.
2. The EUT was set 3 meters from the receiving antenna mounted on the antenna tower.
3. The table was rotated 360 degrees to determine the position of the highest spurious emission.
4. The height of the receiving antenna is varied between 1m to 4m to search the maximum spurious emission for both horizontal and vertical polarizations.
5. During the measurement, the system simulator parameters were set to force the EUT transmitting at maximum output power.
6. Make the measurement with the spectrum analyzer's RBW = 1MHz, VBW = 3MHz, taking the record of maximum spurious emission.
7. A horn antenna was substituted in place of the EUT and was driven by a signal generator. Tune the output power of signal generator to the same emission level with EUT maximum spurious emission.
$$\text{EIRP (dBm)} = \text{S.G. Power} - \text{Tx Cable Loss} + \text{Tx Antenna Gain}$$
$$\text{ERP (dBm)} = \text{EIRP} - 2.15$$
8. The RF fundamental frequency should be excluded against the limit line in the operating frequency band.
The limit line is -40dBm/MHz



5 List of Measuring Equipment

Instrument	Manufacturer	Model No.	Serial No.	Characteristics	Calibration Date	Test Date	Due Date	Remark
Spectrum Analyzer	R&S	FSV40	101040	10Hz~40GHz	Oct. 11, 2023	Mar. 05, 2024~ Mar. 14, 2024	Oct. 10, 2024	Conducted (TH01-KS)
Power divider	STI	STI08-0055	-	0.5~40GHz	NCR	Mar. 05, 2024~ Mar. 14, 2024	NCR	Conducted (TH01-KS)
Temperature & humidity chamber	Hongzhan	LP-150U	H2014011440	-40~+150°C 20%~95%RH	Jul. 06, 2023	Mar. 05, 2024~ Mar. 14, 2024	Jul. 05, 2024	Conducted (TH01-KS)
EXA Spectrum Analyzer	Keysight	N9010B	MY57471079	10Hz~44G,MAX 30dB	Oct. 10, 2023	Feb. 25, 2024	Oct. 09, 2024	Radiation (03CH04-KS)
Loop Antenna	R&S	HFH2-Z2E	101125	9kHz~30MHz	Sep. 11, 2023	Feb. 25, 2024	Sep. 10, 2024	Radiation (03CH04-KS)
Bilog Antenna	TeseQ	CBL6111D	49922	30MHz-1GHz	Apr. 09, 2023	Feb. 25, 2024	Apr. 08, 2024	Radiation (03CH04-KS)
Double Ridge Horn Antenna	ETS-Lindgren	3117	00251694	1GHz~18GHz	Jul. 12, 2023	Feb. 25, 2024	Jul. 11, 2024	Radiation (03CH04-KS)
SHF-EHF Horn	Com-power	AH-840	101070	18GHz~40GHz	Jan. 05, 2023	Feb. 25, 2024	Jan. 04, 2024	Radiation (03CH04-KS)
Amplifier	SONOMA	310N	380827	9KHz-1GHz	Jul. 06, 2023	Feb. 25, 2024	Jul. 05, 2024	Radiation (03CH04-KS)
Amplifier	MITEQ	EM18G40G GA	060728	18~40GHz	Jan. 05, 2023	Feb. 25, 2024	Jan. 04, 2024	Radiation (03CH04-KS)
high gain Amplifier	EM	EM01G18G A	060840	1Ghz-18Ghz	Oct. 10, 2023	Feb. 25, 2024	Oct. 09, 2024	Radiation (03CH04-KS)
Amplifier	Agilent	8449B	3008A02370	1Ghz-18Ghz	Oct. 10, 2023	Feb. 25, 2024	Oct. 09, 2024	Radiation (03CH04-KS)
AC Power Source	Chroma	61601	F104090004	N/A	NCR	Feb. 25, 2024	NCR	Radiation (03CH04-KS)
Turn Table	ChamPro	EM 1000-T	060762-T	0~360 degree	NCR	Feb. 25, 2024	NCR	Radiation (03CH04-KS)
Antenna Mast	ChamPro	EM 1000-A	060762-A	1 m~4 m	NCR	Feb. 25, 2024	NCR	Radiation (03CH04-KS)

NCR: No Calibration Required



6 Measurement Uncertainty

Uncertainty of Conducted Measurement

Conducted Spurious Emission & Bandedge	±2.26 dB
Occupied Channel Bandwidth	±0.1%
Conducted Power	±0.46 dB
Peak to Average Ratio	±0.46 dB
Frequency Stability	±0.4 ppm

Uncertainty of Radiated Emission Measurement (30 MHz ~ 1000 MHz)

Measuring Uncertainty for a Level of Confidence of 95% (U = 2Uc(y))	3.82dB
---	--------

Uncertainty of Radiated Emission Measurement (1 GHz ~ 18 GHz)

Measuring Uncertainty for a Level of Confidence of 95% (U = 2Uc(y))	3.56dB
---	--------

Uncertainty of Radiated Emission Measurement (18 GHz ~ 40 GHz)

Measuring Uncertainty for a Level of Confidence of 95% (U = 2Uc(y))	3.54dB
---	--------

----- THE END -----



Appendix A. Test Results of Conducted Test

Test Engineer :	Simle Wang	Temperature :	22~23°C
		Relative Humidity :	40~42%

Conducted Output Power(Average power) and EIRP

LTE Band 48_Ant 6:

BW [MHz]	Modulation	RB Size	RB Offset	Power Low	Power Middle	Power High	EIRP		
				Ch. / Freq.	Ch. / Freq.	Ch. / Freq.	L	M	H
Channel				55340	55990	56640			
Frequency (MHz)				3560	3625	3690	L	M	H
20	QPSK	1	0	21.56	21.41	21.32	0.1337	0.1291	0.1265
20	QPSK	1	49	22.69	22.48	22.38	0.1734	0.1652	0.1614
20	QPSK	1	99	21.64	21.47	21.42	0.1361	0.1309	0.1294
20	QPSK	50	0	22.84	22.63	22.47	0.1795	0.1710	0.1648
20	QPSK	50	24	22.79	22.69	22.53	0.1774	0.1734	0.1671
20	QPSK	50	50	22.78	22.59	22.55	0.1770	0.1694	0.1679
20	QPSK	100	0	21.79	21.52	21.49	0.1409	0.1324	0.1315
20	16QAM	1	0	20.90	20.53	20.33	0.1148	0.1054	0.1007
20	16QAM	1	49	22.73	22.59	22.38	0.1750	0.1694	0.1614
20	16QAM	1	99	20.67	20.49	20.40	0.1089	0.1045	0.1023
20	16QAM	50	0	22.87	22.67	22.50	0.1807	0.1726	0.1660
20	16QAM	50	24	22.79	22.70	22.52	0.1774	0.1738	0.1667
20	16QAM	50	50	22.78	22.56	22.56	0.1770	0.1683	0.1683
20	16QAM	100	0	20.76	20.64	20.53	0.1112	0.1081	0.1054
20	64QAM	1	0	19.84	19.45	19.45	0.0899	0.0822	0.0822
20	64QAM	1	49	22.87	22.63	22.50	0.1807	0.1710	0.1660
20	64QAM	1	99	19.78	19.74	19.50	0.0887	0.0879	0.0832
20	64QAM	50	0	21.84	21.63	21.46	0.1426	0.1358	0.1306
20	64QAM	50	24	21.85	21.65	21.56	0.1429	0.1365	0.1337
20	64QAM	50	50	21.77	21.61	21.56	0.1403	0.1352	0.1337
20	64QAM	100	0	19.77	19.64	19.50	0.0885	0.0859	0.0832
20	256QAM	1	0	16.71	16.47	16.46	0.0438	0.0414	0.0413
20	256QAM	1	49	19.73	19.44	19.41	0.0877	0.0820	0.0815
20	256QAM	1	99	16.64	16.48	16.41	0.0431	0.0415	0.0408
20	256QAM	50	0	19.87	19.65	19.47	0.0906	0.0861	0.0826
20	256QAM	50	24	19.79	19.70	19.60	0.0889	0.0871	0.0851
20	256QAM	50	50	19.72	19.59	19.61	0.0875	0.0849	0.0853
20	256QAM	100	0	17.81	17.75	17.55	0.0564	0.0556	0.0531
Channel				55315	55990	56665	EIRP		
Frequency (MHz)				3557.5	3625	3692.5	L	M	H
15	QPSK	1	0	21.63	21.46	21.27	0.1358	0.1306	0.1250
15	QPSK	1	37	22.72	22.54	22.33	0.1746	0.1675	0.1596
15	QPSK	1	74	21.67	21.49	21.45	0.1371	0.1315	0.1303
15	QPSK	36	0	22.87	22.66	22.44	0.1807	0.1722	0.1637
15	QPSK	36	20	22.76	22.63	22.50	0.1762	0.1710	0.1660



15	QPSK	36	39	22.78	22.60	22.47	0.1770	0.1698	0.1648
15	QPSK	75	0	22.78	22.63	22.46	0.1770	0.1710	0.1644
15	16QAM	1	0	20.68	20.48	20.36	0.1091	0.1042	0.1014
15	16QAM	1	37	22.74	22.57	22.41	0.1754	0.1687	0.1626
15	16QAM	1	74	20.75	20.60	20.42	0.1109	0.1072	0.1028
15	16QAM	36	0	22.84	22.67	22.44	0.1795	0.1726	0.1637
15	16QAM	36	20	22.80	22.69	22.52	0.1778	0.1734	0.1667
15	16QAM	36	39	22.79	22.61	22.49	0.1774	0.1702	0.1656
15	16QAM	75	0	21.77	21.64	21.52	0.1403	0.1361	0.1324
15	64QAM	1	0	19.85	19.69	19.38	0.0902	0.0869	0.0809
15	64QAM	1	37	22.91	22.68	22.48	0.1824	0.1730	0.1652
15	64QAM	1	74	19.85	19.56	19.49	0.0902	0.0843	0.0830
15	64QAM	36	0	21.91	21.65	21.49	0.1449	0.1365	0.1315
15	64QAM	36	20	21.80	21.69	21.52	0.1413	0.1377	0.1324
15	64QAM	36	39	21.82	21.59	21.48	0.1419	0.1346	0.1312
15	64QAM	75	0	20.80	20.62	20.47	0.1122	0.1076	0.1040
15	256QAM	1	0	16.81	16.51	16.37	0.0448	0.0418	0.0405
15	256QAM	1	37	19.90	19.53	19.42	0.0912	0.0838	0.0817
15	256QAM	1	74	16.84	16.68	16.57	0.0451	0.0435	0.0424
15	256QAM	36	0	19.78	19.66	19.43	0.0887	0.0863	0.0818
15	256QAM	36	20	19.78	19.66	19.46	0.0887	0.0863	0.0824
15	256QAM	36	39	19.78	19.60	19.45	0.0887	0.0851	0.0822
15	256QAM	75	0	18.77	18.65	18.52	0.0703	0.0684	0.0664
Channel				55290	55990	56690	EIRP		
Frequency (MHz)				3555	3625	3695	L	M	H
10	QPSK	1	0	22.80	22.58	22.48	0.1778	0.1690	0.1652
10	QPSK	1	25	22.75	22.52	22.66	0.1758	0.1667	0.1722
10	QPSK	1	49	22.95	22.53	22.61	0.1841	0.1671	0.1702
10	QPSK	25	0	22.90	22.68	22.54	0.1820	0.1730	0.1675
10	QPSK	25	12	22.86	22.65	22.58	0.1803	0.1718	0.1690
10	QPSK	25	25	22.80	22.60	22.55	0.1778	0.1698	0.1679
10	QPSK	50	0	22.89	22.66	22.53	0.1816	0.1722	0.1671
10	16QAM	1	0	22.76	22.55	22.43	0.1762	0.1679	0.1633
10	16QAM	1	25	22.93	22.61	22.53	0.1832	0.1702	0.1671
10	16QAM	1	49	22.97	22.68	22.47	0.1849	0.1730	0.1648
10	16QAM	25	0	22.88	22.65	22.53	0.1811	0.1718	0.1671
10	16QAM	25	12	22.92	22.69	22.61	0.1828	0.1734	0.1702
10	16QAM	25	25	22.83	22.60	22.59	0.1791	0.1698	0.1694
10	16QAM	50	0	22.92	22.67	22.54	0.1828	0.1726	0.1675
10	64QAM	1	0	22.74	22.69	22.57	0.1754	0.1734	0.1687
10	64QAM	1	25	22.82	22.78	22.60	0.1786	0.1770	0.1698
10	64QAM	1	49	22.86	22.67	22.55	0.1803	0.1726	0.1679
10	64QAM	25	0	21.88	21.71	21.57	0.1439	0.1384	0.1340
10	64QAM	25	12	21.94	21.73	21.59	0.1459	0.1390	0.1346
10	64QAM	25	25	21.84	21.66	21.57	0.1426	0.1368	0.1340
10	64QAM	50	0	21.93	21.68	21.56	0.1455	0.1374	0.1337
10	256QAM	1	0	19.79	19.47	19.36	0.0889	0.0826	0.0805
10	256QAM	1	25	19.74	19.47	19.58	0.0879	0.0826	0.0847
10	256QAM	1	49	19.62	19.39	19.44	0.0855	0.0811	0.0820
10	256QAM	25	0	19.92	19.70	19.57	0.0916	0.0871	0.0845



10	256QAM	25	12	19.91	19.72	19.64	0.0914	0.0875	0.0859
10	256QAM	25	25	19.79	19.61	19.62	0.0889	0.0853	0.0855
10	256QAM	50	0	19.90	19.67	19.56	0.0912	0.0865	0.0843
Channel				55265	55990	56715	EIRP		
Frequency (MHz)				3552.5	3625	3697.5	L	M	H
5	QPSK	1	0	22.93	22.68	22.65	0.1832	0.1730	0.1718
5	QPSK	1	12	22.85	22.73	22.53	0.1799	0.1750	0.1671
5	QPSK	1	24	22.83	22.73	22.62	0.1791	0.1750	0.1706
5	QPSK	12	0	22.88	22.69	22.55	0.1811	0.1734	0.1679
5	QPSK	12	7	22.90	22.69	22.57	0.1820	0.1734	0.1687
5	QPSK	12	13	22.78	22.62	22.53	0.1770	0.1706	0.1671
5	QPSK	25	0	22.79	22.68	22.59	0.1774	0.1730	0.1694
5	16QAM	1	0	22.82	22.90	22.58	0.1786	0.1820	0.1690
5	16QAM	1	12	22.77	22.55	22.49	0.1766	0.1679	0.1656
5	16QAM	1	24	22.74	22.79	22.50	0.1754	0.1774	0.1660
5	16QAM	12	0	22.88	22.71	22.49	0.1811	0.1742	0.1656
5	16QAM	12	7	22.90	22.74	22.61	0.1820	0.1754	0.1702
5	16QAM	12	13	22.82	22.62	22.58	0.1786	0.1706	0.1690
5	16QAM	25	0	22.83	22.69	22.57	0.1791	0.1734	0.1687
5	64QAM	1	0	23.02	22.67	22.54	0.1871	0.1726	0.1675
5	64QAM	1	12	22.92	22.67	22.62	0.1828	0.1726	0.1706
5	64QAM	1	24	22.98	22.58	22.51	0.1854	0.1690	0.1663
5	64QAM	12	0	21.89	21.68	21.53	0.1442	0.1374	0.1327
5	64QAM	12	7	21.92	21.72	21.61	0.1452	0.1387	0.1352
5	64QAM	12	13	21.77	21.63	21.49	0.1403	0.1358	0.1315
5	64QAM	25	0	21.83	21.67	21.58	0.1422	0.1371	0.1343
5	256QAM	1	0	19.84	19.39	19.64	0.0899	0.0811	0.0859
5	256QAM	1	12	19.85	19.61	19.52	0.0902	0.0853	0.0836
5	256QAM	1	24	19.68	19.48	19.55	0.0867	0.0828	0.0841
5	256QAM	12	0	19.88	19.68	19.50	0.0908	0.0867	0.0832
5	256QAM	12	7	19.92	19.76	19.61	0.0916	0.0883	0.0853
5	256QAM	12	13	19.80	19.64	19.57	0.0891	0.0859	0.0845
5	256QAM	25	0	19.79	19.65	19.61	0.0889	0.0861	0.0853



LTE Band 48

ACLR

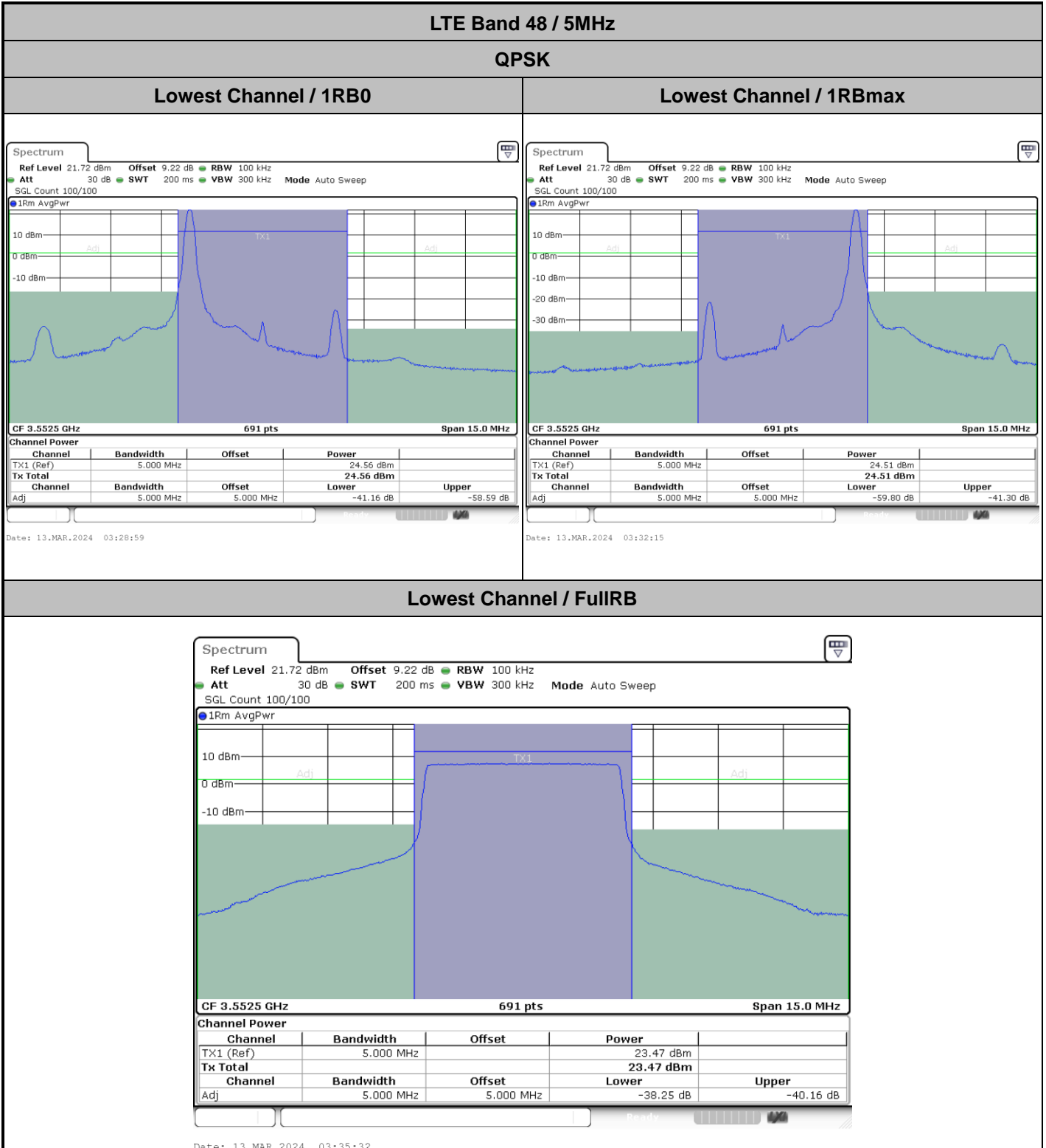



LTE Band 48 / 5MHz

QPSK

Middle Channel / 1RB0

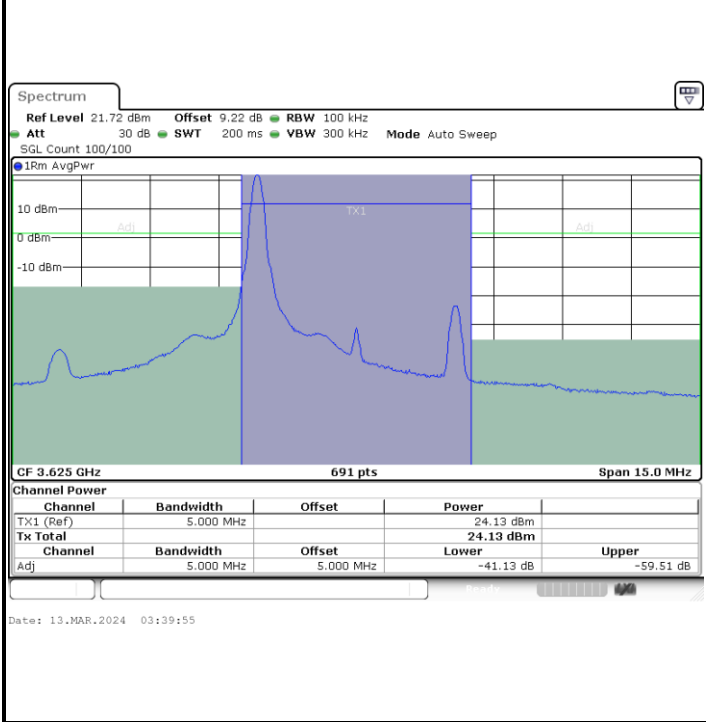

Middle Channel / 1RBmax

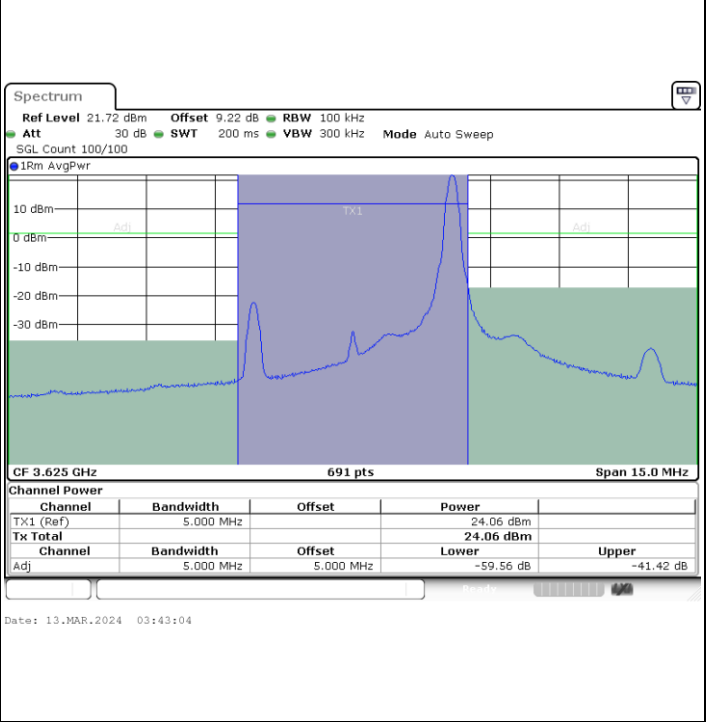

Middle Channel / FullIRB

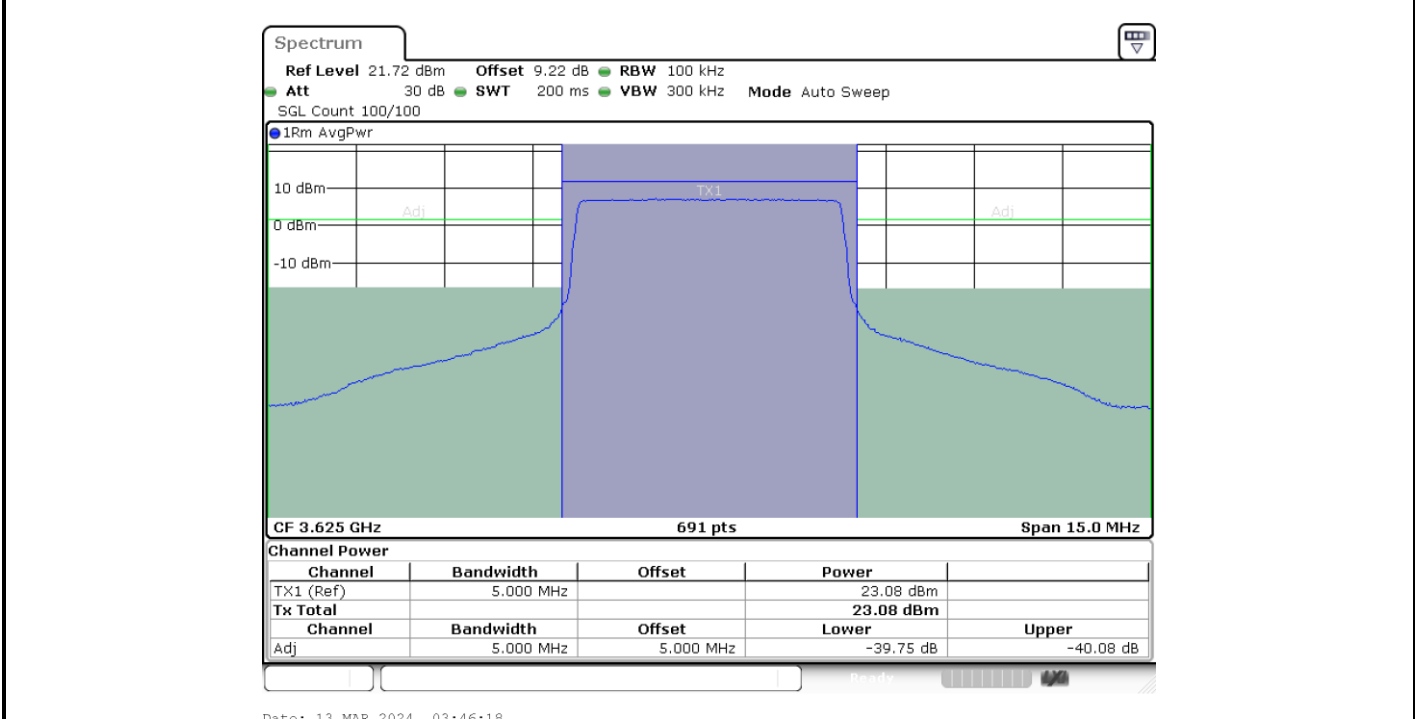



LTE Band 48 / 5MHz

QPSK

Highest Channel / 1RB0

Highest Channel / 1RBmax

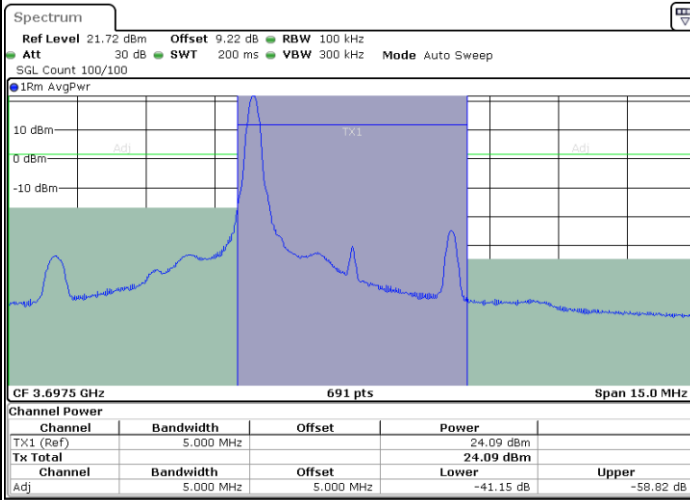

Date: 13.MAR.2024 03:49:28

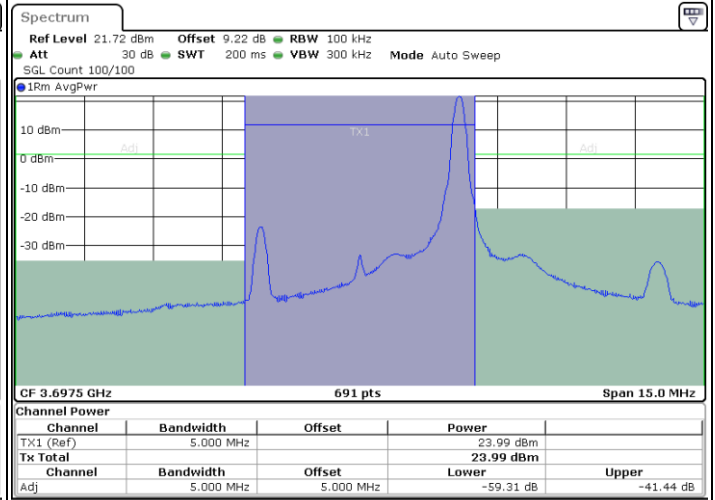

Date: 13.MAR.2024 03:52:47

Highest Channel / Full RB

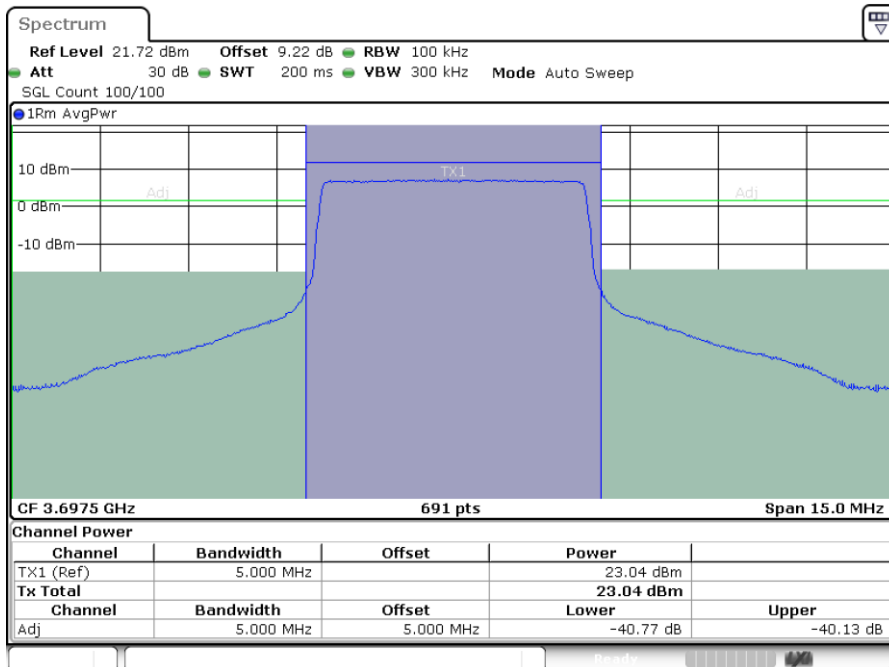

Date: 13.MAR.2024 03:56:05



LTE Band 48 / 5MHz

16QAM

Lowest Channel / 1RB0

Lowest Channel / 1RBmax

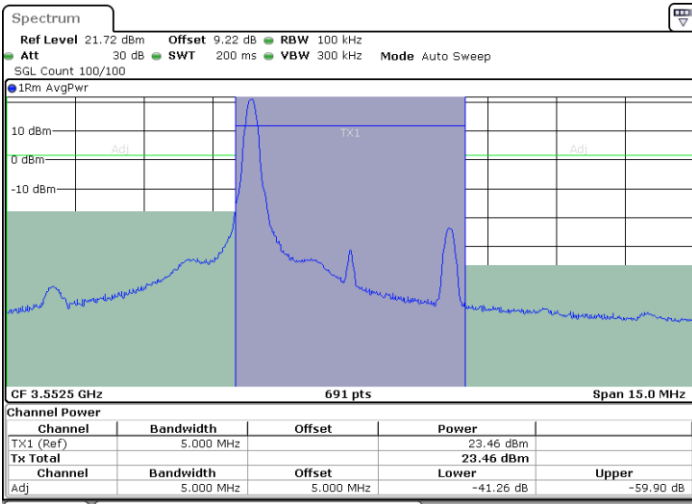

Date: 13.MAR.2024 03:29:47

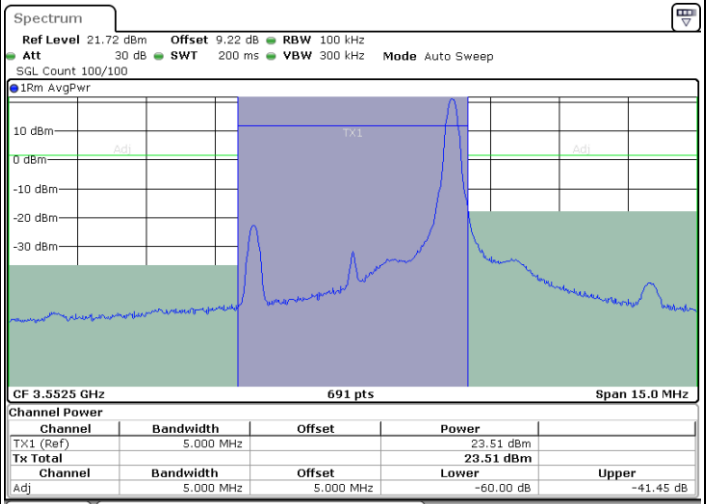

Date: 13.MAR.2024 03:33:05

Lowest Channel / FullRB

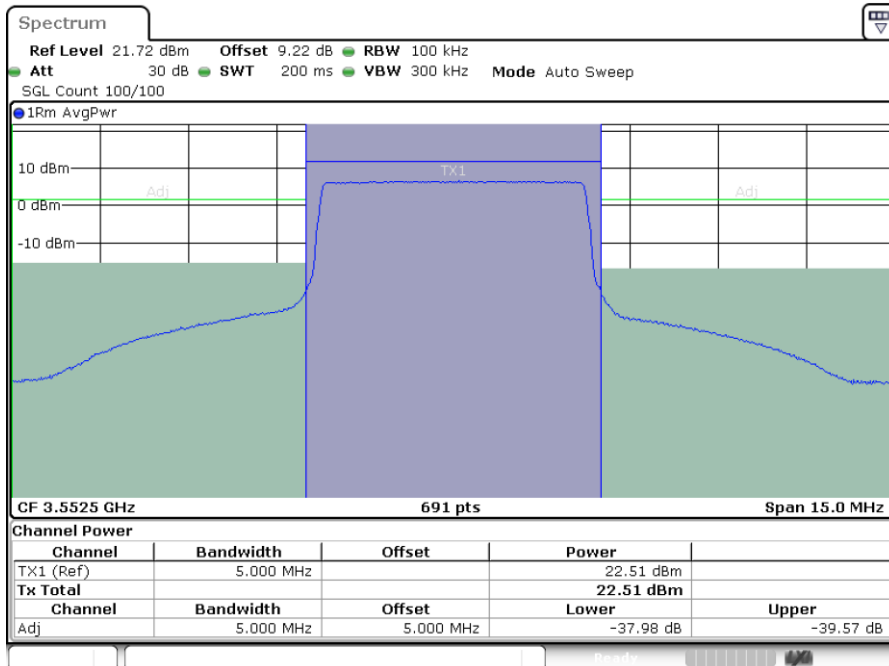

Date: 13.MAR.2024 03:36:23



LTE Band 48 / 5MHz

16QAM

Middle Channel / 1RB0

Middle Channel / 1RBmax

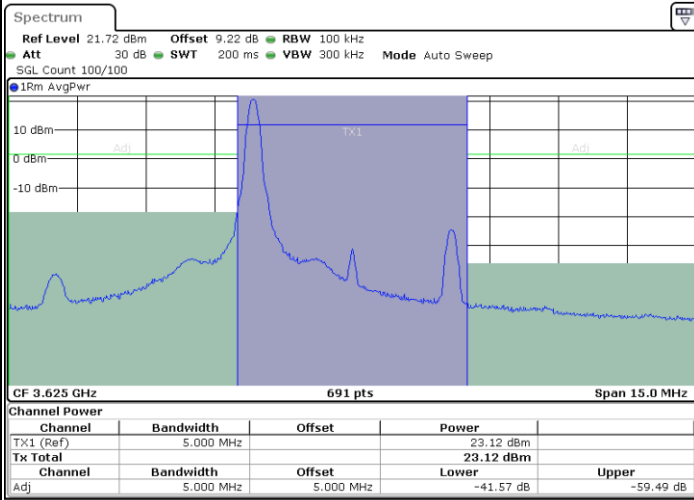

Date: 13.MAR.2024 03:40:42

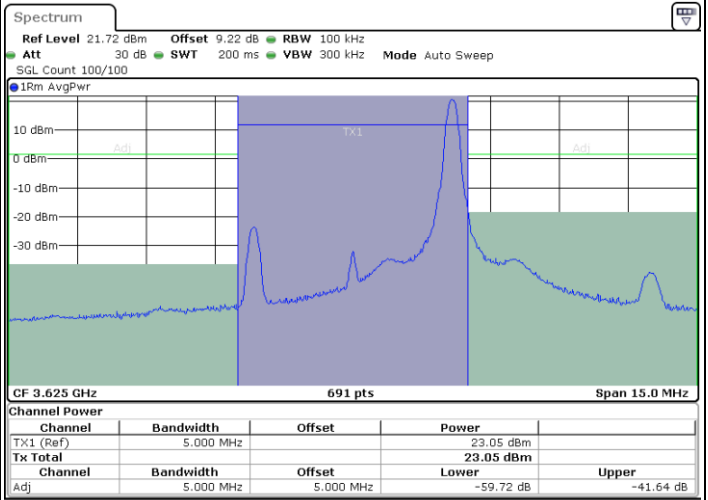

Date: 13.MAR.2024 03:43:54

Middle Channel / FullIRB

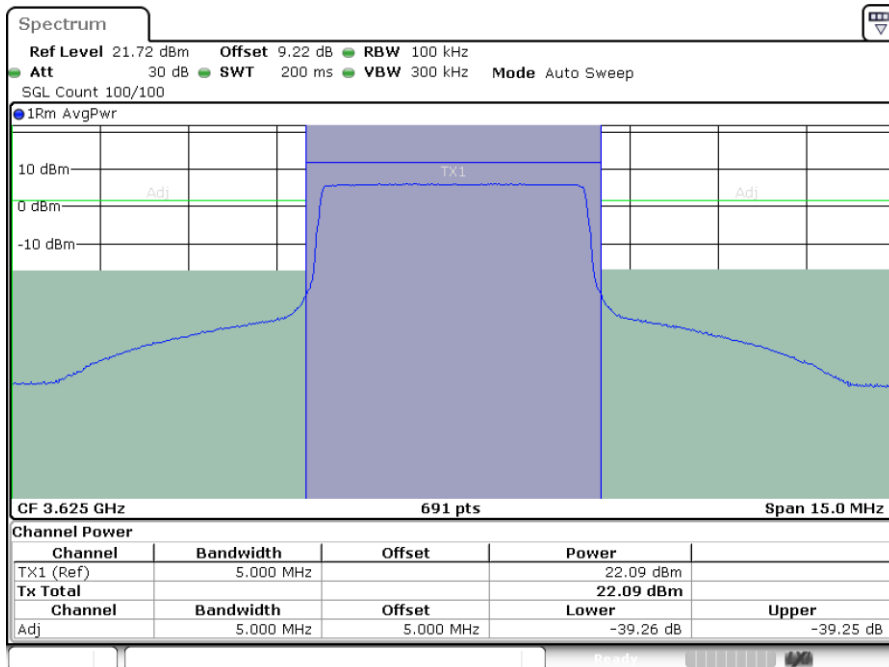

Date: 13.MAR.2024 03:47:03



LTE Band 48 / 5MHz

16QAM

Highest Channel / 1RB0

Highest Channel / 1RBmax

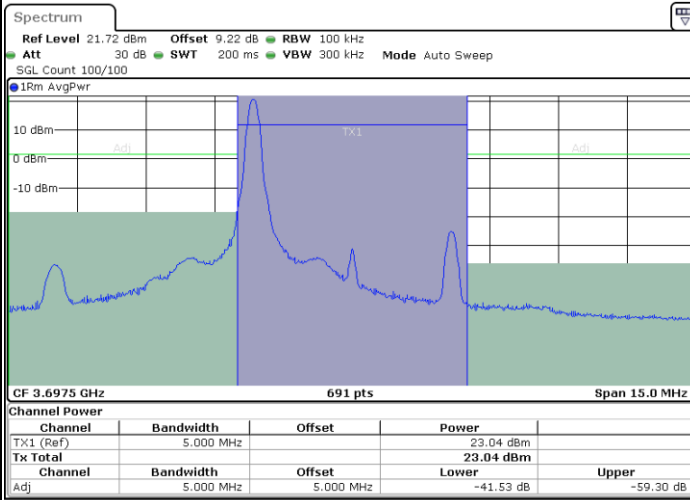

Date: 13.MAR.2024 03:50:16

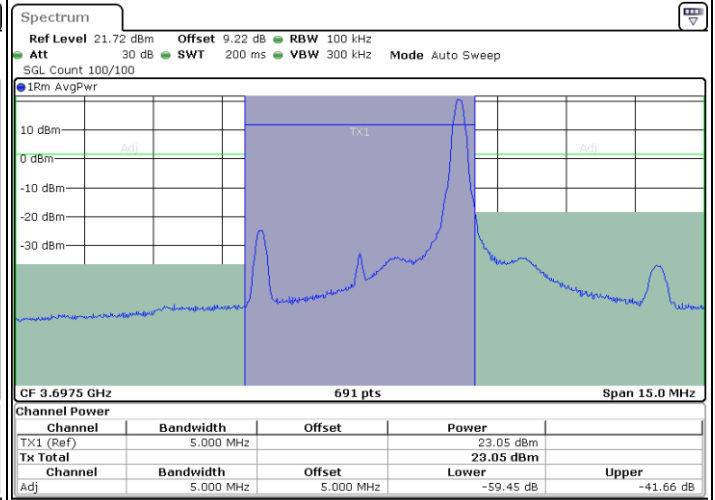

Date: 13.MAR.2024 03:53:39

Highest Channel / Full RB

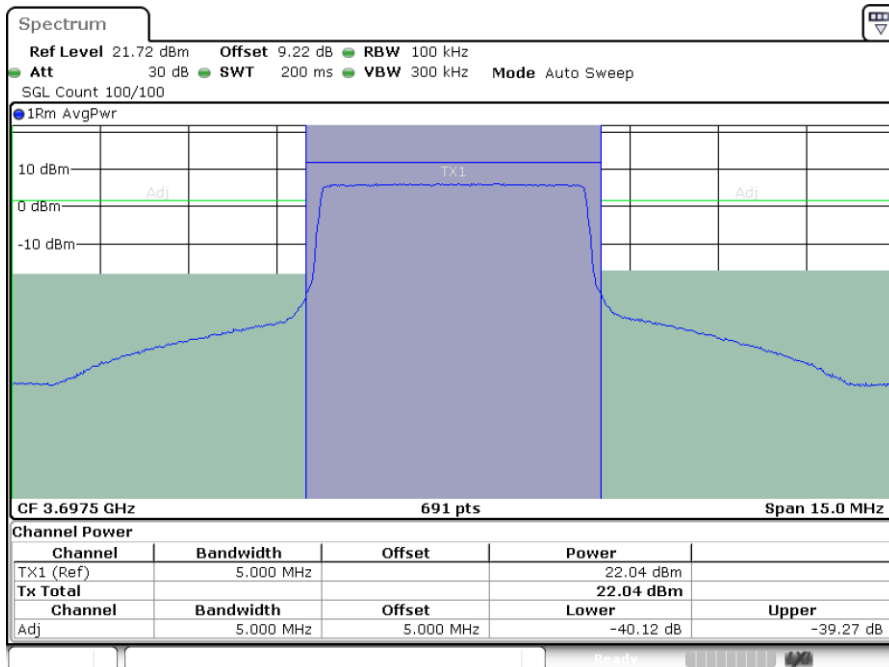

Date: 13.MAR.2024 03:56:53



LTE Band 48 / 5MHz

64QAM

Lowest Channel / 1RB0

Lowest Channel / 1RBmax

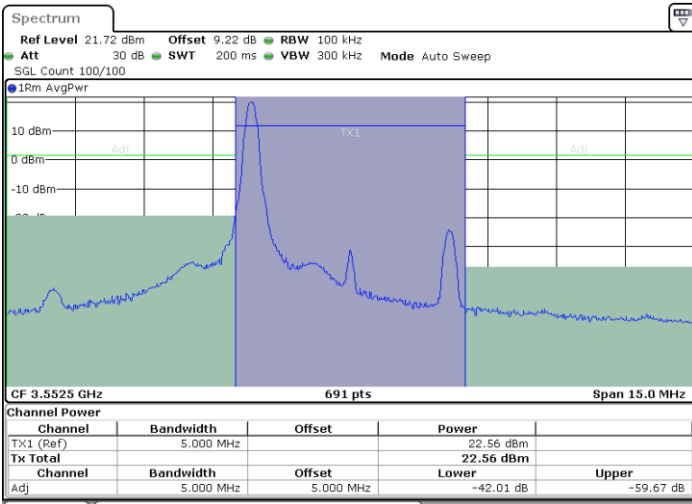

Date: 13.MAR.2024 03:30:38

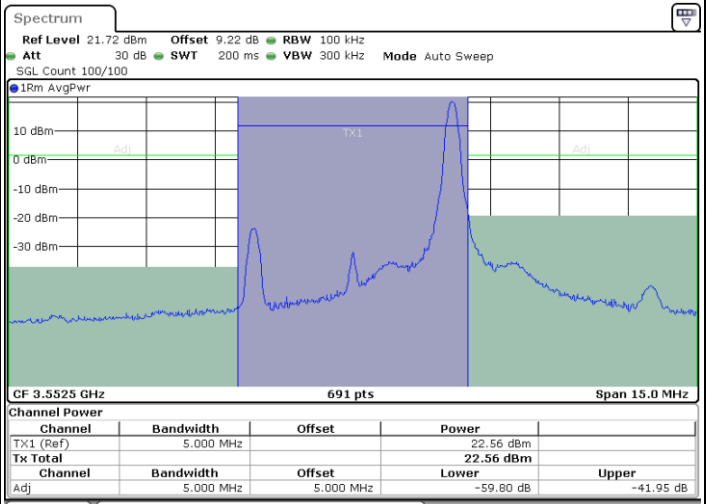

Date: 13.MAR.2024 03:33:52

Lowest Channel / FullRB

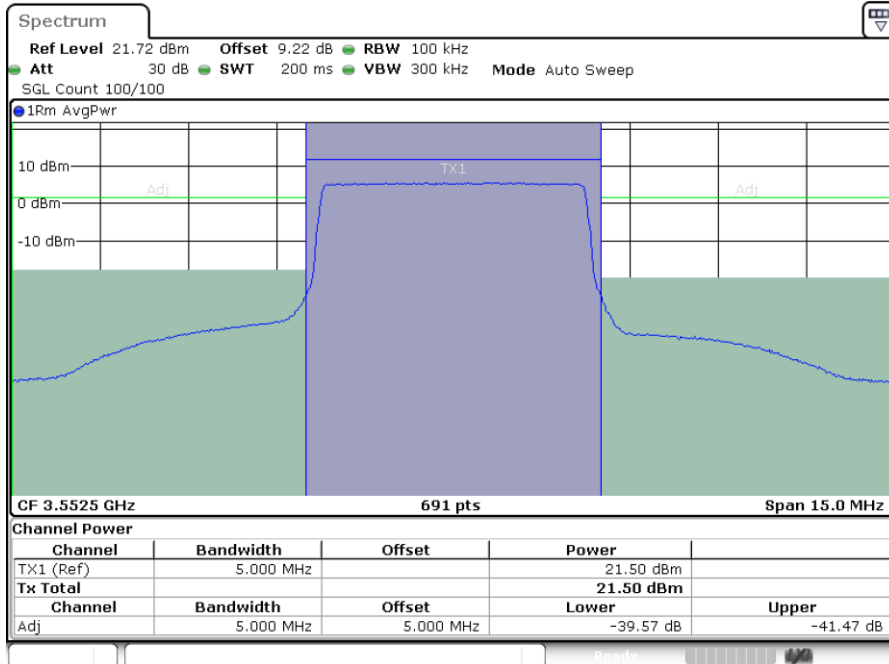

Date: 13.MAR.2024 03:37:11



LTE Band 48 / 5MHz

64QAM

Middle Channel / 1RB0

Middle Channel / 1RBmax

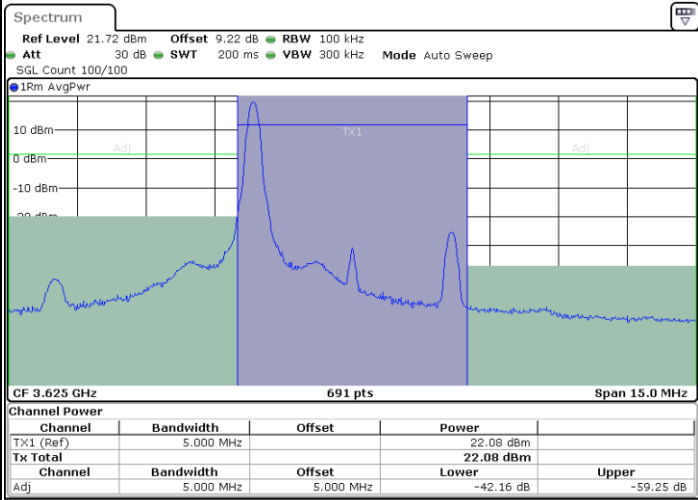

Date: 13.MAR.2024 03:41:32

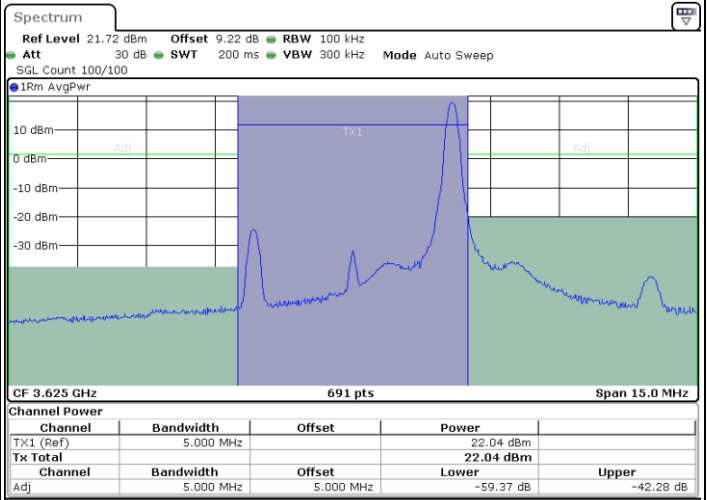

Date: 13.MAR.2024 03:44:40

Middle Channel / FullIRB

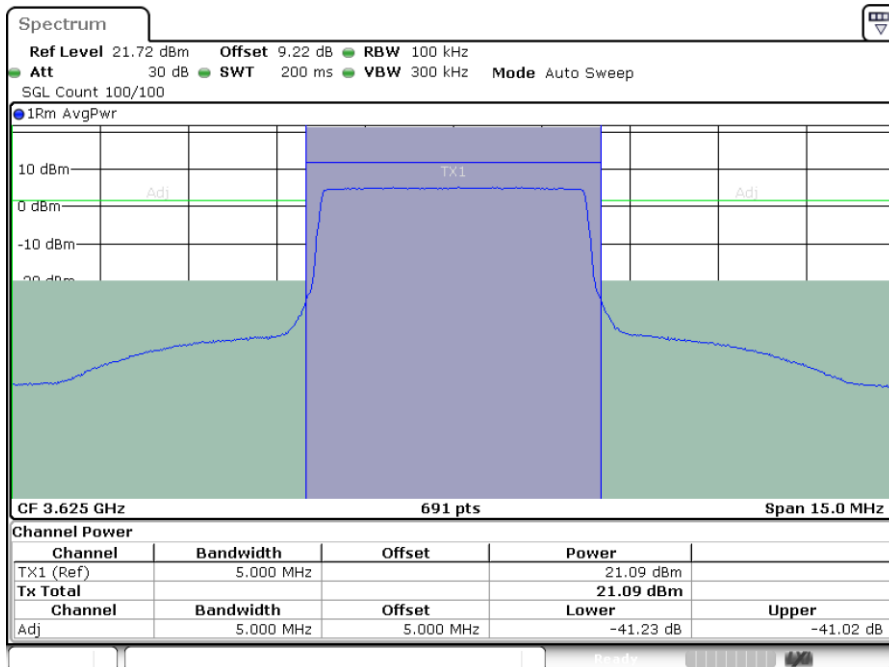

Date: 13.MAR.2024 03:47:50



LTE Band 48 / 5MHz

64QAM

Highest Channel / 1RB0

Highest Channel / 1RBmax

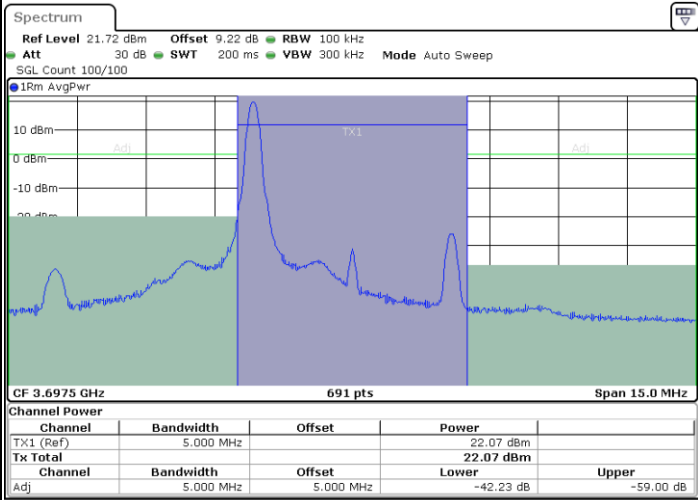

Date: 13.MAR.2024 03:51:07

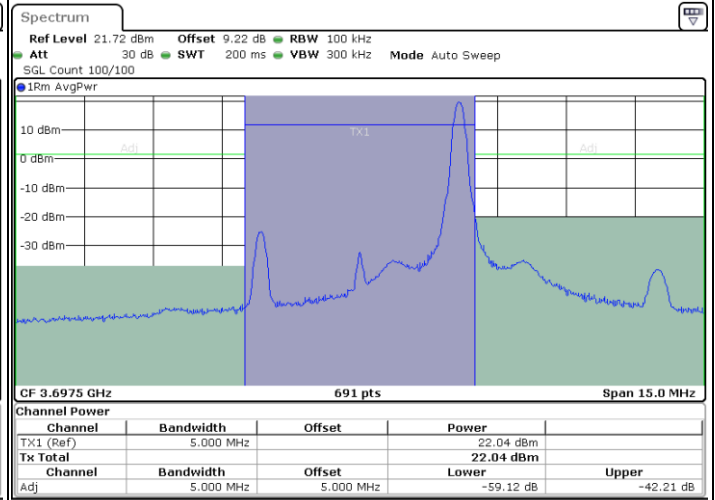

Date: 13.MAR.2024 03:54:25

Highest Channel / Full RB

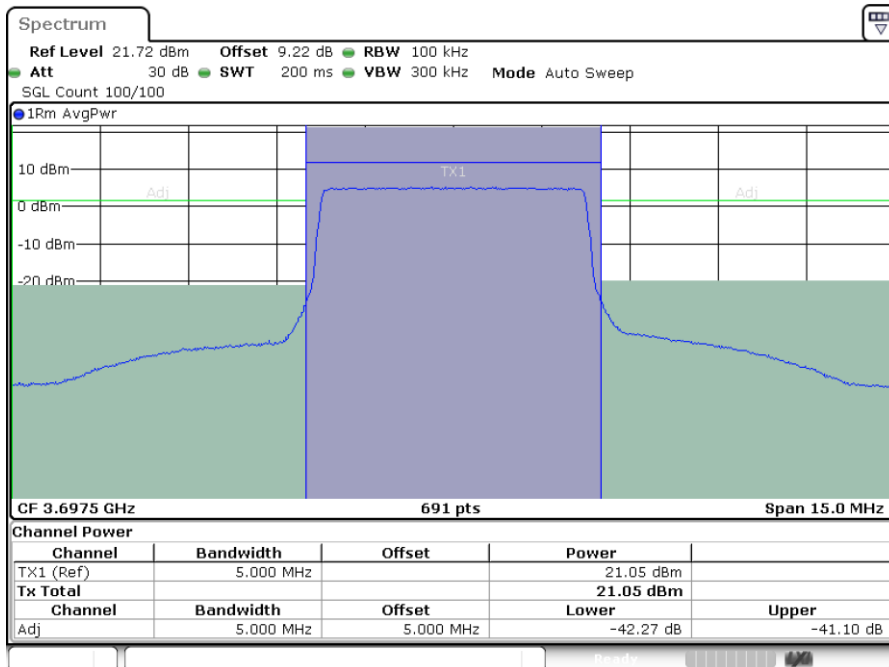

Date: 13.MAR.2024 03:57:41



LTE Band 48 / 5MHz

256QAM

Lowest Channel / 1RB0

Lowest Channel / 1RBmax

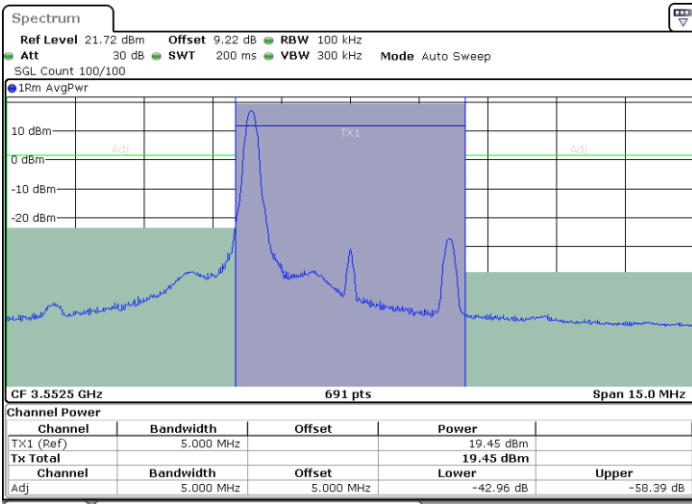

Date: 13.MAR.2024 03:31:24

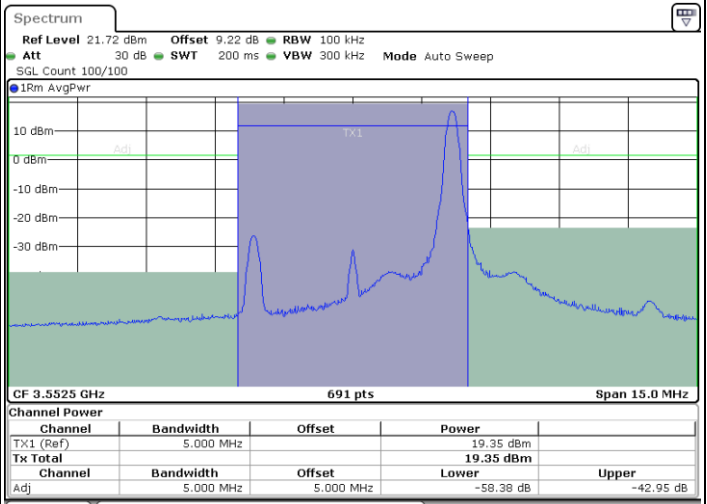

Date: 13.MAR.2024 03:34:40

Lowest Channel / FullRB

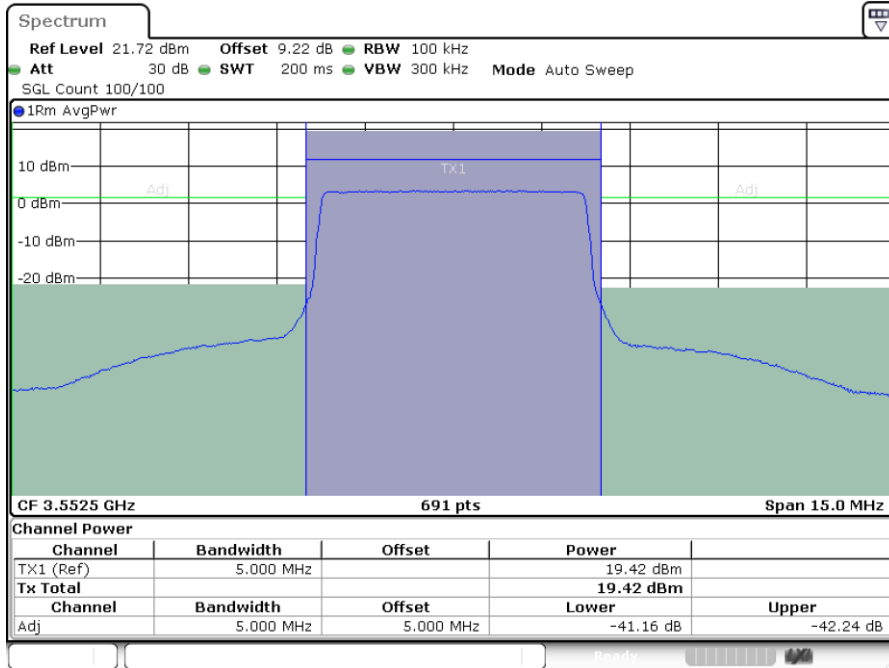

Date: 13.MAR.2024 03:38:02



LTE Band 48 / 5MHz

256QAM

Middle Channel / 1RB0

Middle Channel / 1RBmax

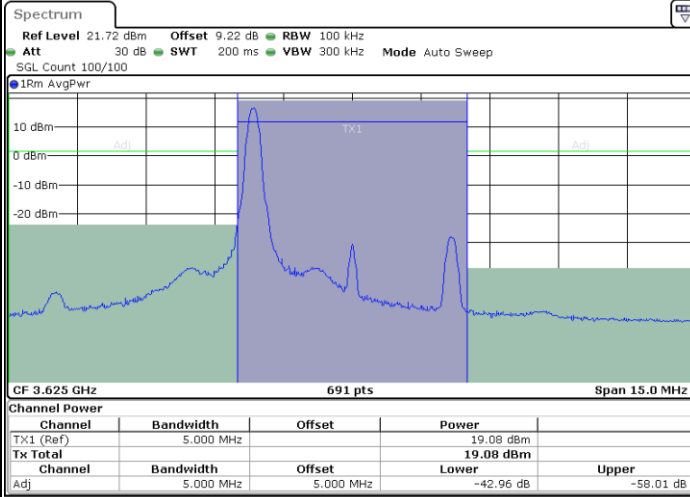

Date: 13.MAR.2024 03:42:18

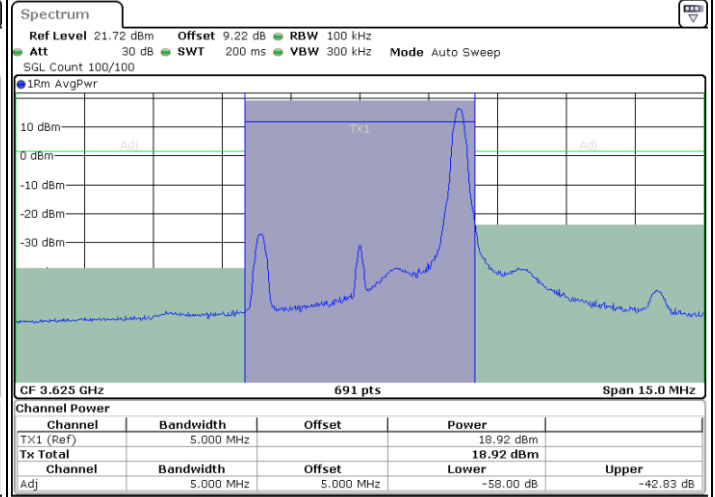

Date: 13.MAR.2024 03:45:28

Middle Channel / FullIRB

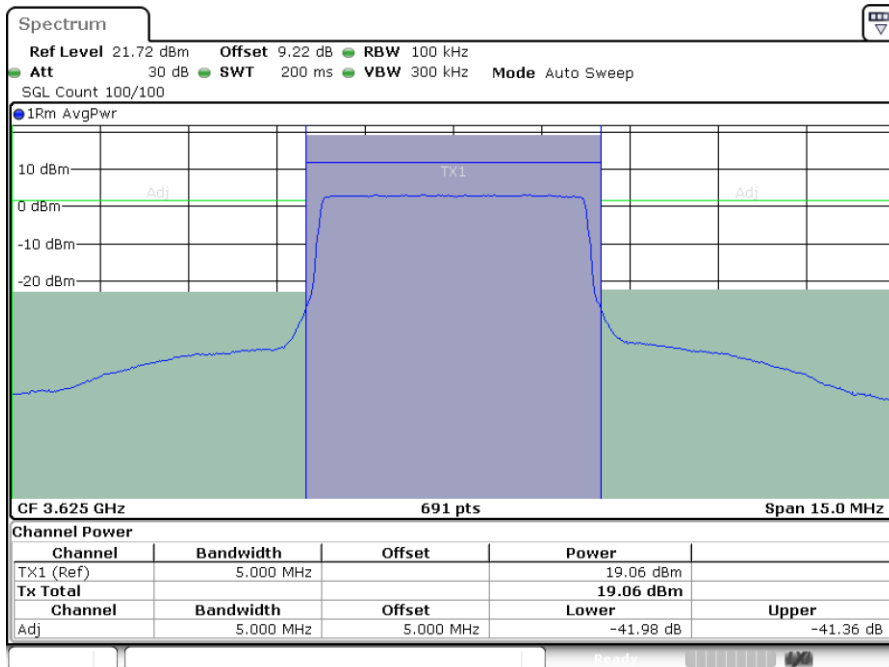

Date: 13.MAR.2024 03:48:40



LTE Band 48 / 5MHz

256QAM

Highest Channel / 1RB0

Highest Channel / 1RBmax

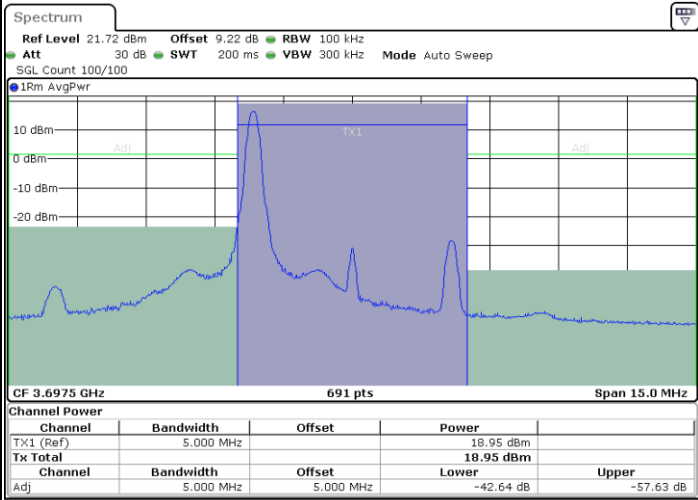

Date: 13.MAR.2024 03:51:55

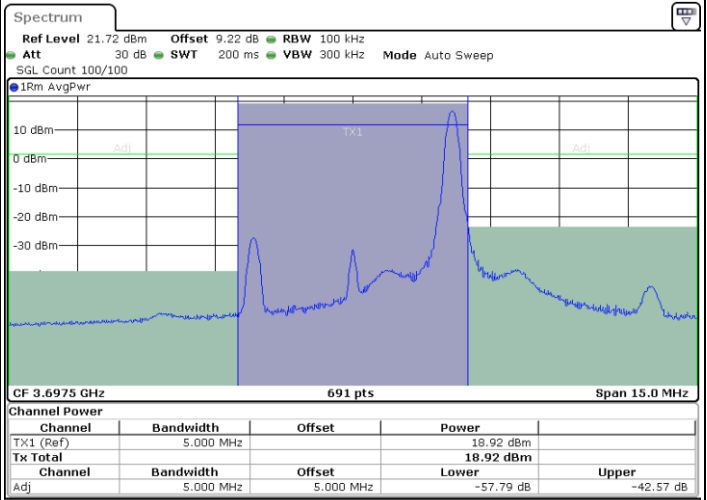

Date: 13.MAR.2024 03:55:13

Highest Channel / FullRB

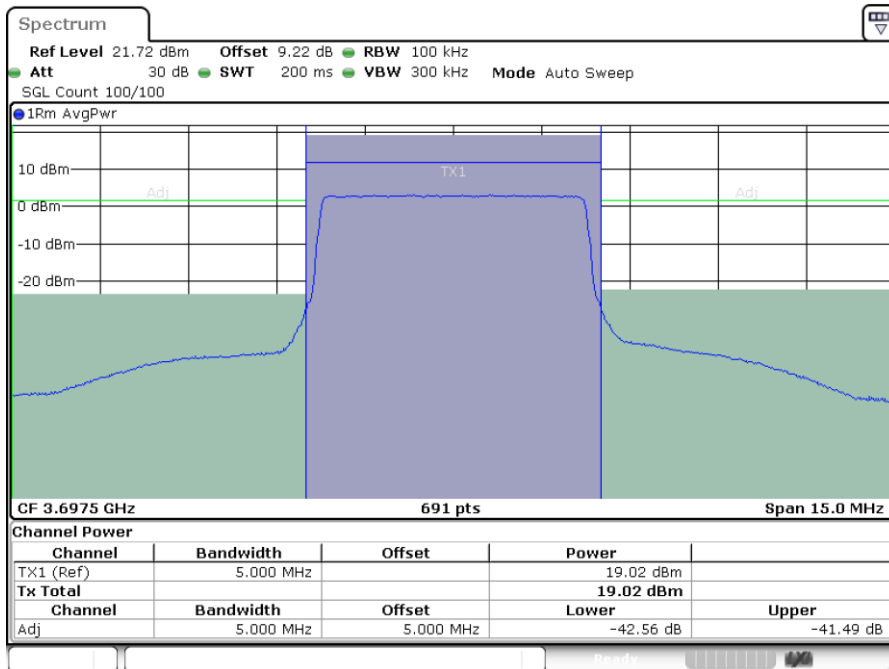

Date: 13.MAR.2024 03:58:32



LTE Band 48 / 10MHz

QPSK

Lowest Channel / 1RB0

Lowest Channel / 1RBmax

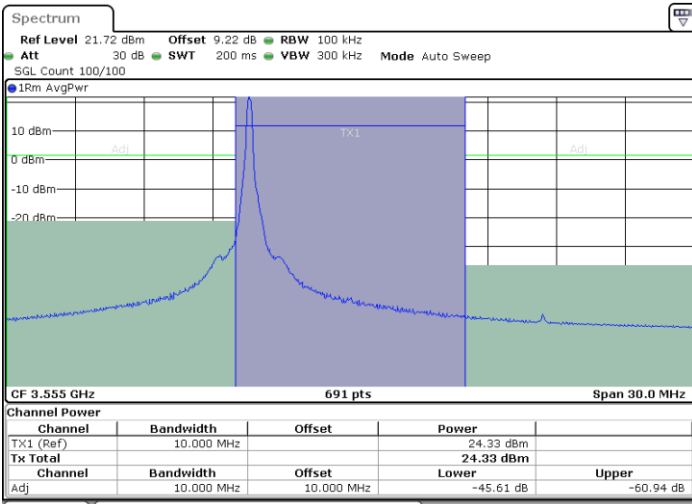

Date: 13.MAR.2024 03:59:58

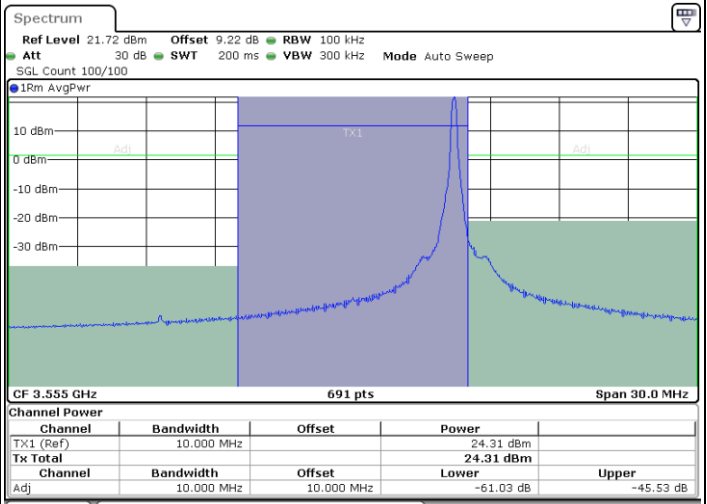

Date: 13.MAR.2024 04:03:14

Lowest Channel / FullRB

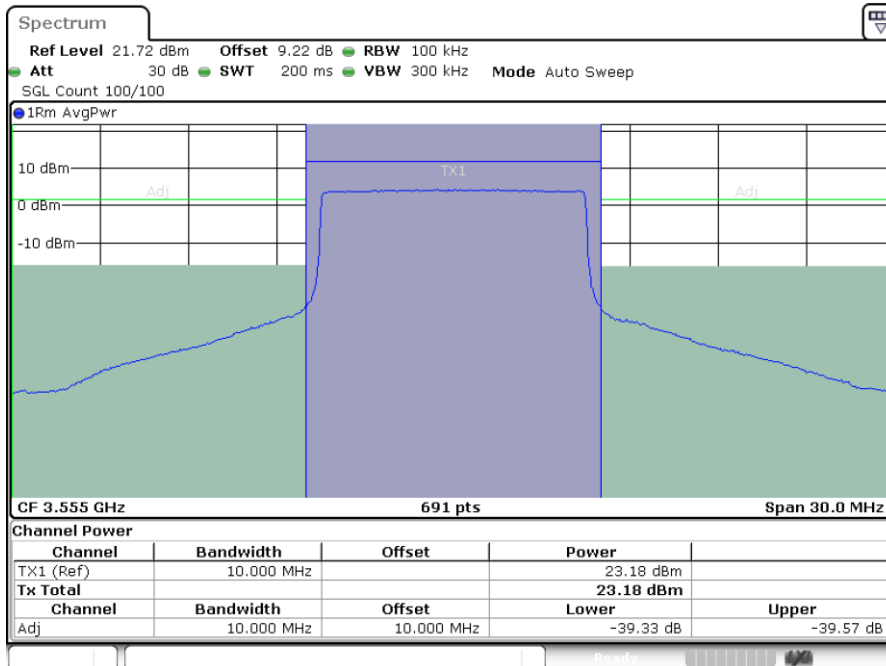

Date: 13.MAR.2024 04:06:30



LTE Band 48 / 10MHz

QPSK

Middle Channel / 1RB0

Middle Channel / 1RBmax

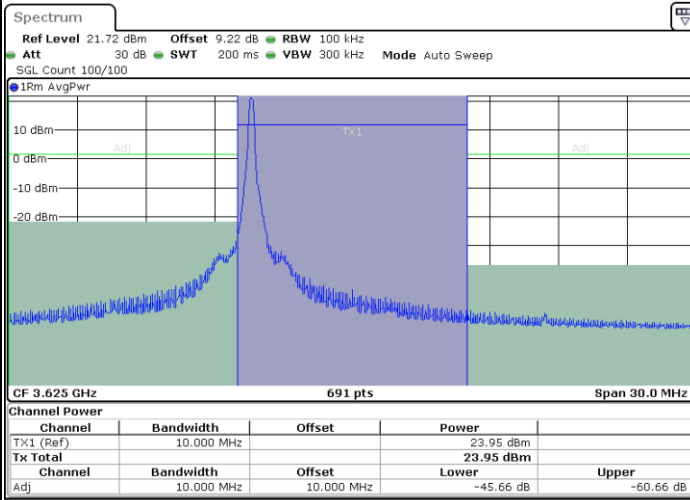

Date: 13.MAR.2024 04:10:48

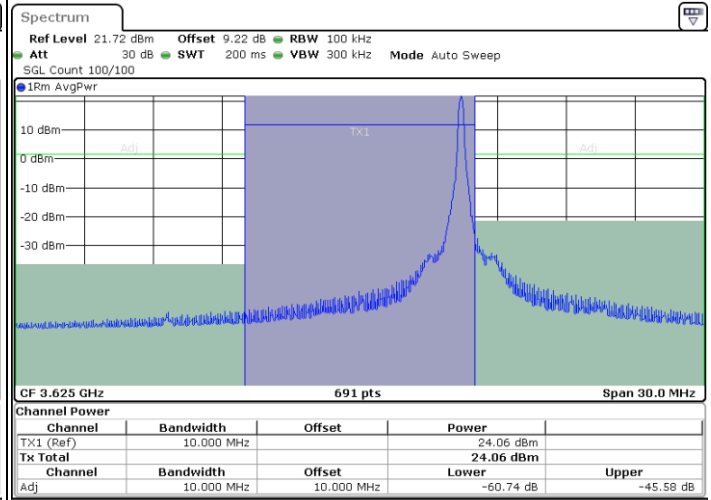

Date: 13.MAR.2024 04:14:01

Middle Channel / FullRB

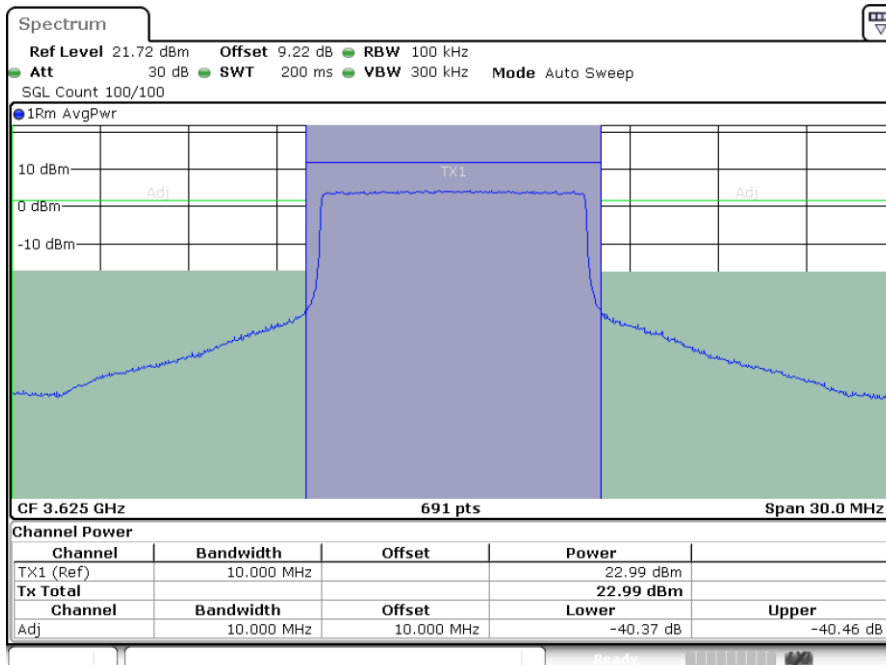

Date: 13.MAR.2024 04:17:16



LTE Band 48 / 10MHz

QPSK

Highest Channel / 1RB0

Highest Channel / 1RBmax

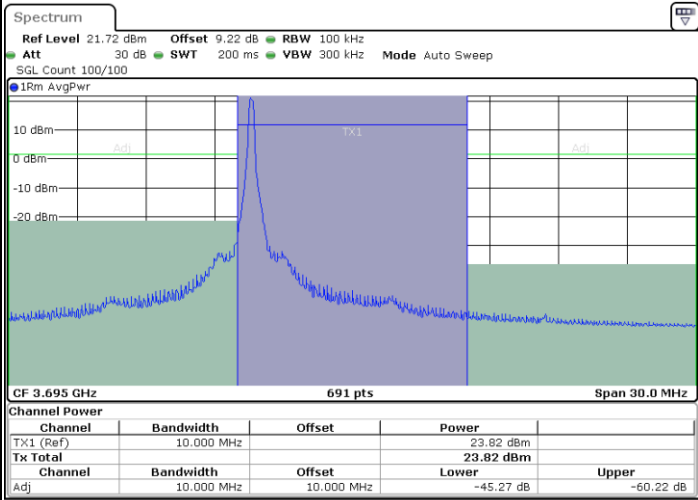

Date: 13.MAR.2024 04:20:26

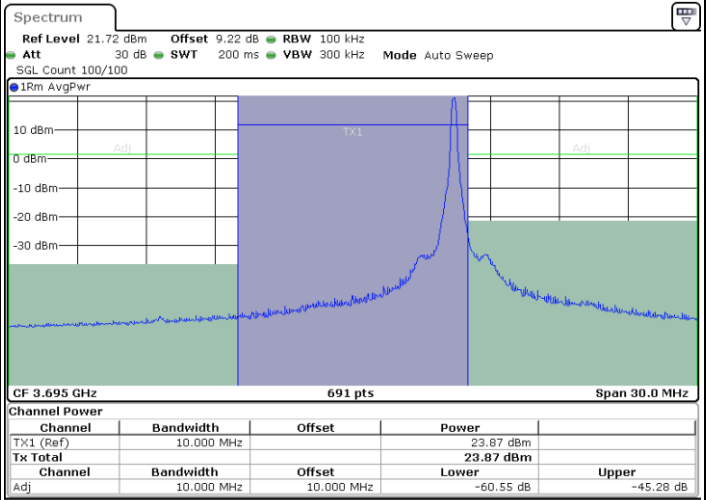

Date: 13.MAR.2024 04:23:42

Highest Channel / FullRB

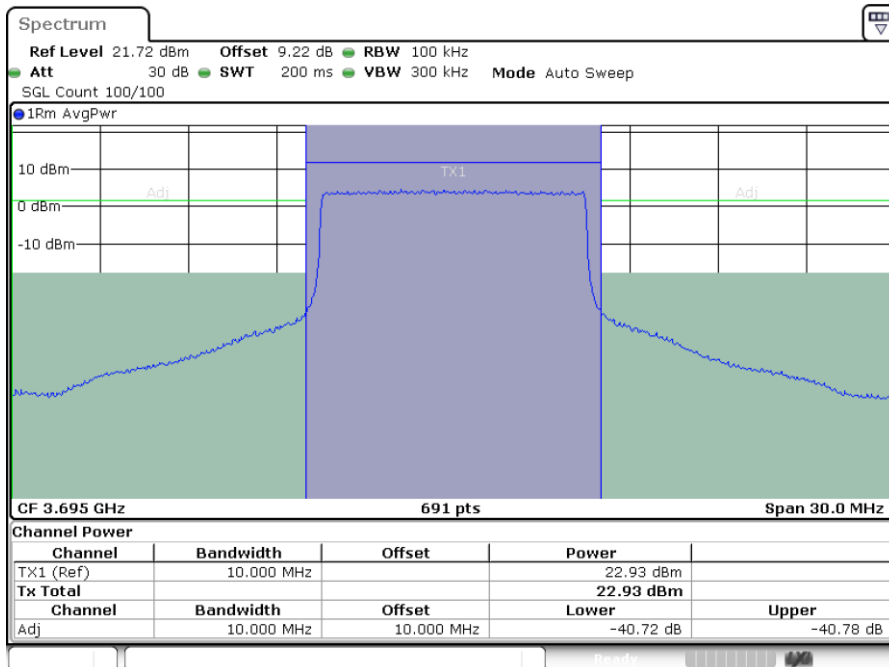

Date: 13.MAR.2024 04:27:02



LTE Band 48 / 10MHz

16QAM

Lowest Channel / 1RB0

Lowest Channel / 1RBmax

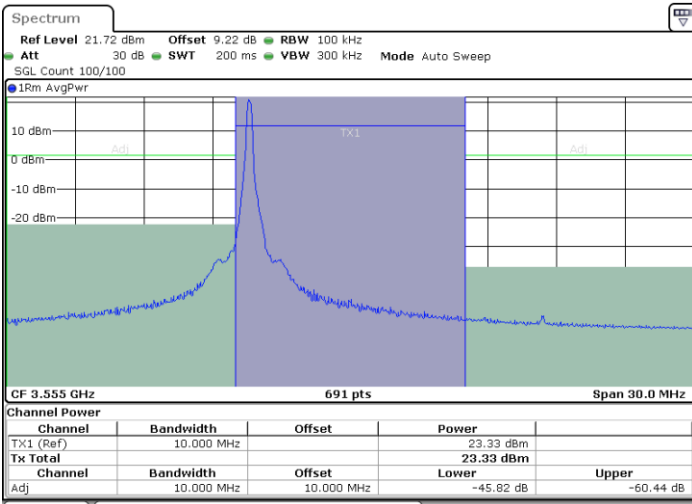

Date: 13.MAR.2024 04:00:46

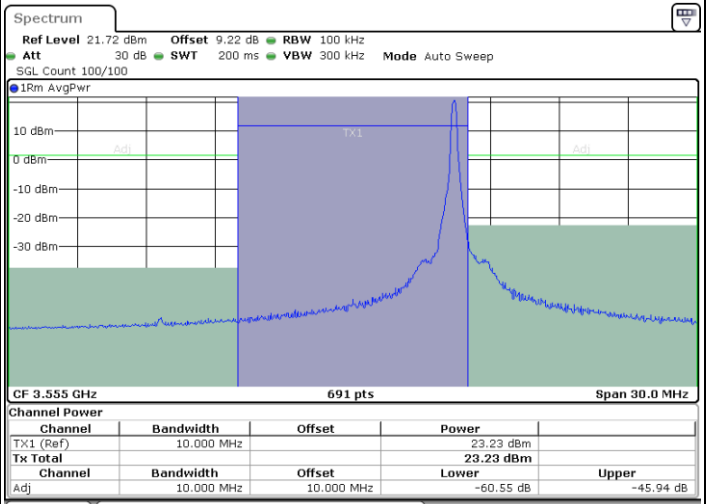

Date: 13.MAR.2024 04:04:04

Lowest Channel / FullRB

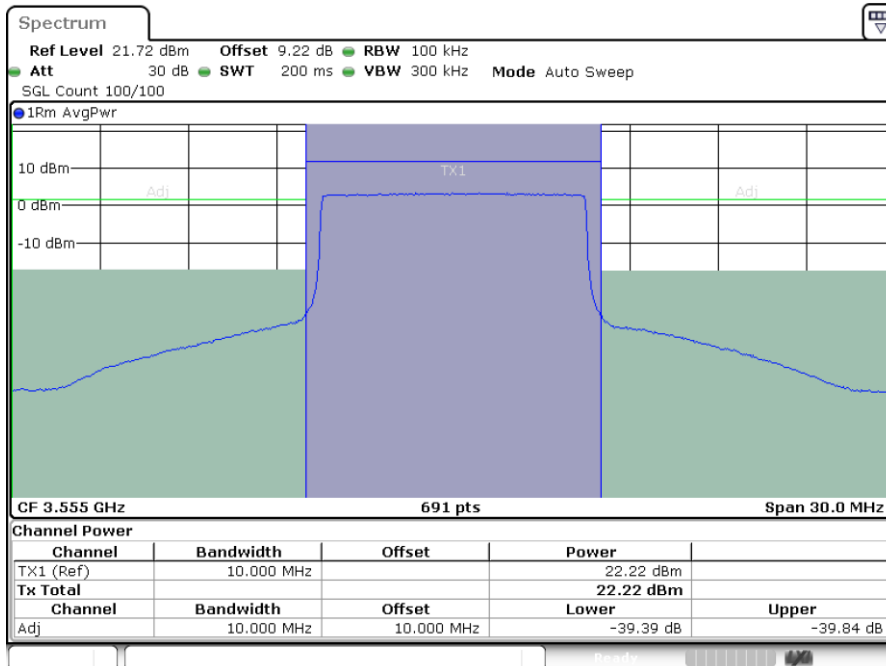

Date: 13.MAR.2024 04:07:17



LTE Band 48 / 10MHz

16QAM

Middle Channel / 1RB0

Middle Channel / 1RBmax

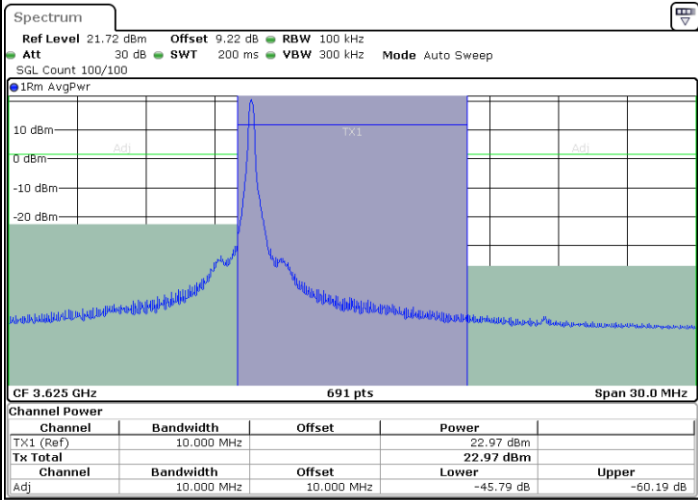

Date: 13.MAR.2024 04:11:36

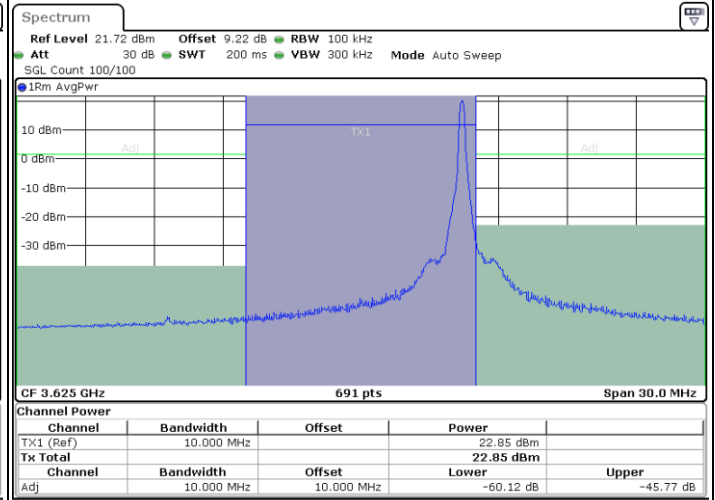

Date: 13.MAR.2024 04:14:52

Middle Channel / FullRB

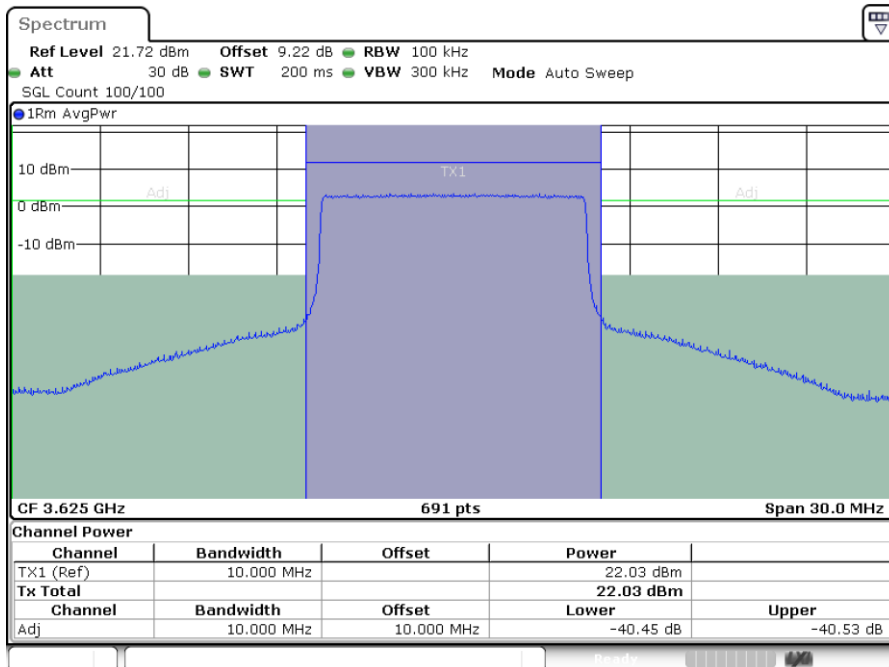

Date: 13.MAR.2024 04:18:02



LTE Band 48 / 10MHz

16QAM

Highest Channel / 1RB0

Highest Channel / 1RBmax

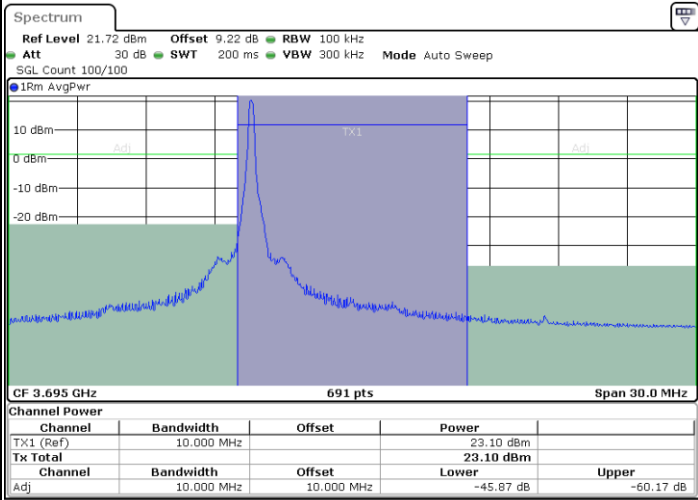

Date: 13.MAR.2024 04:21:15

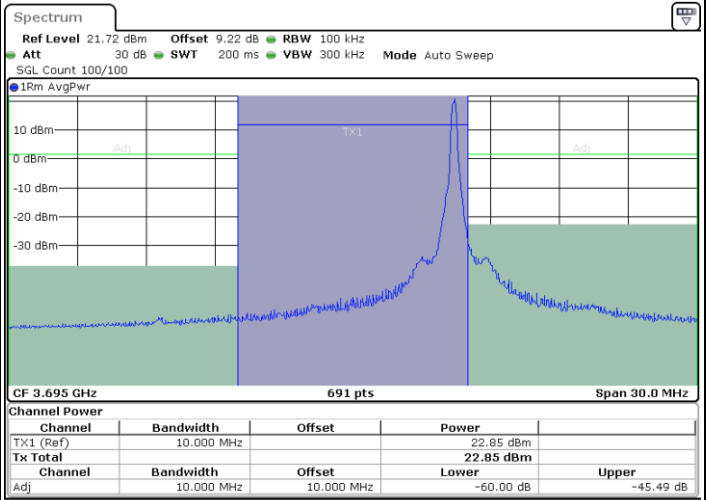

Date: 13.MAR.2024 04:24:34

Highest Channel / FullRB

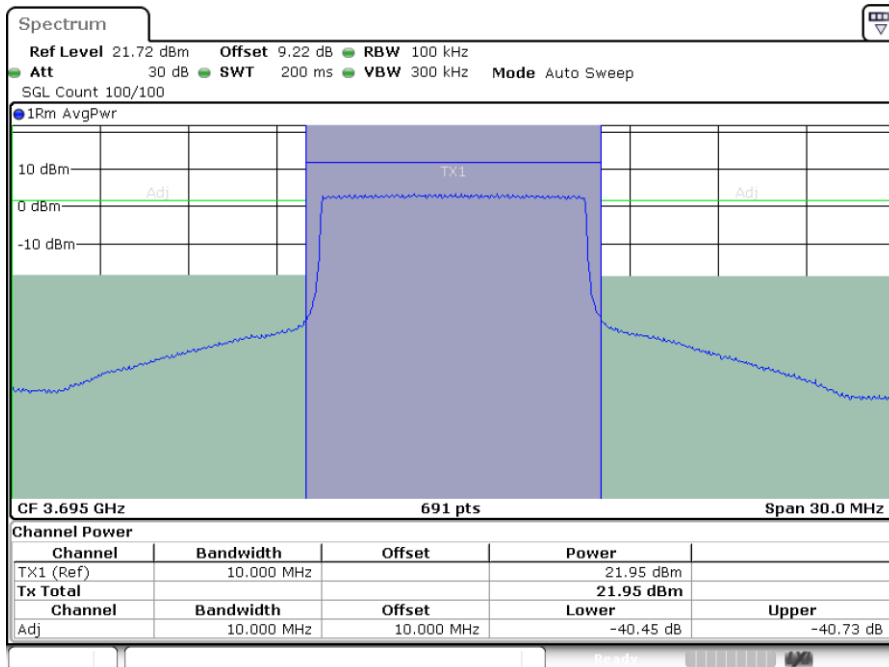

Date: 13.MAR.2024 04:27:49



LTE Band 48 / 10MHz

64QAM

Middle Channel / 1RB0

Middle Channel / 1RBmax

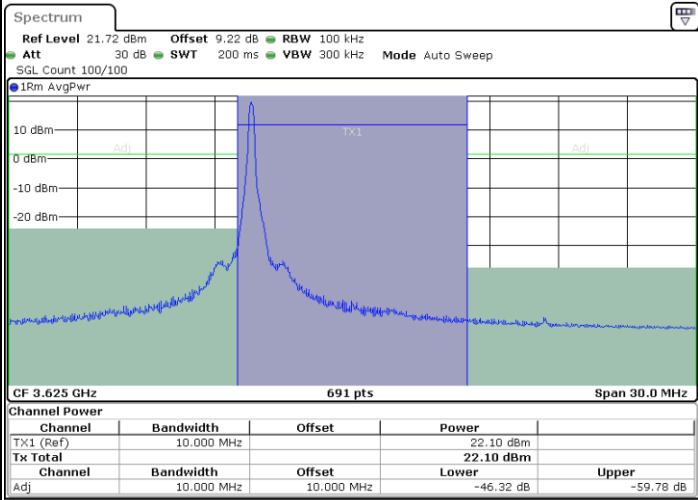

Date: 13.MAR.2024 04:12:27

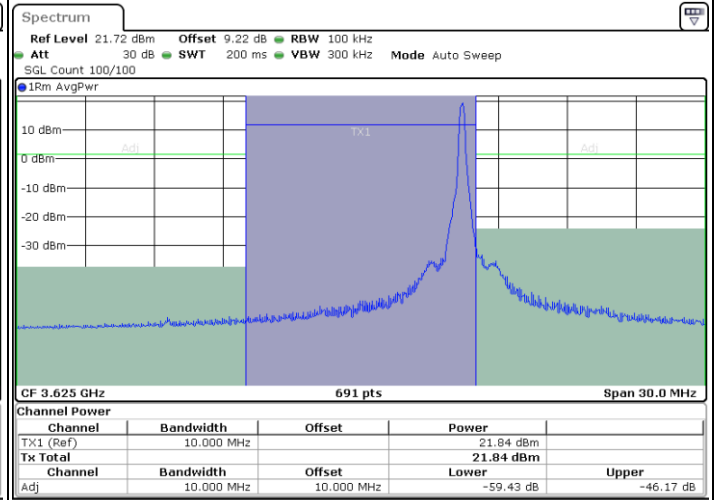

Date: 13.MAR.2024 04:15:39

Middle Channel / FullRB

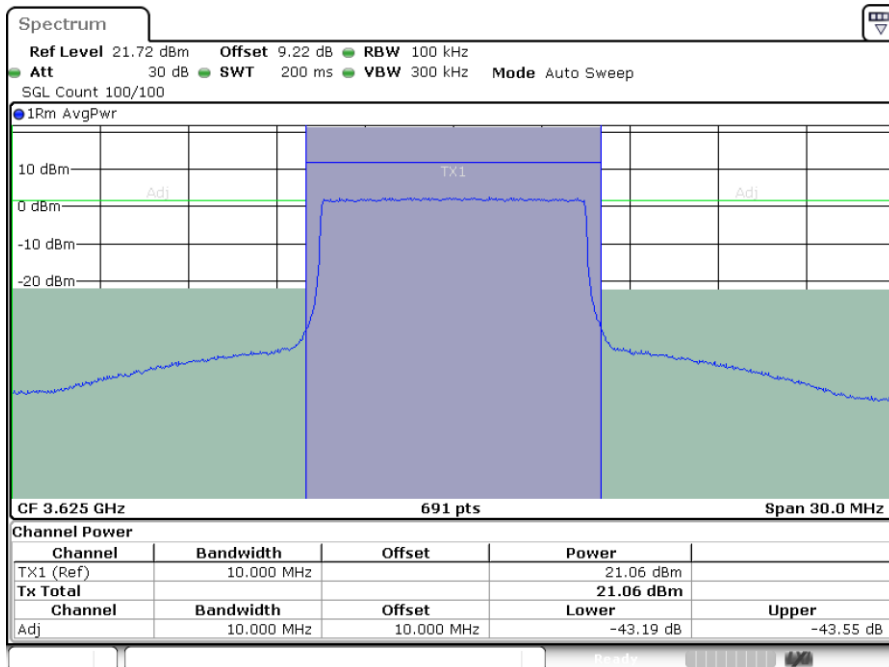

Date: 13.MAR.2024 04:18:49



LTE Band 48 / 10MHz

64QAM

Highest Channel / 1RB0

Highest Channel / 1RBmax

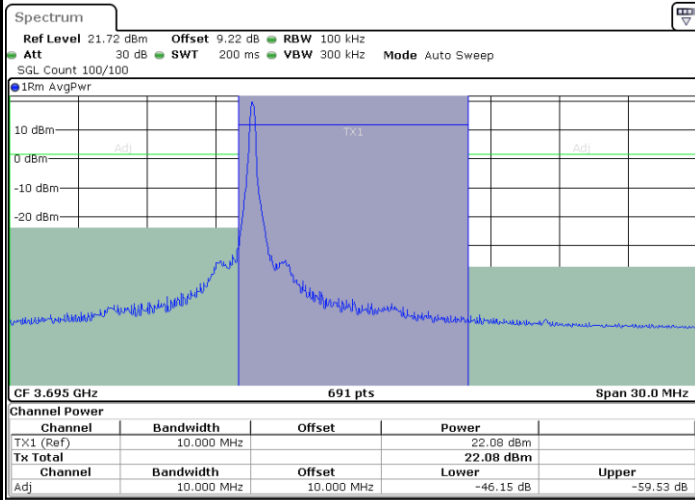

Date: 13.MAR.2024 04:22:06

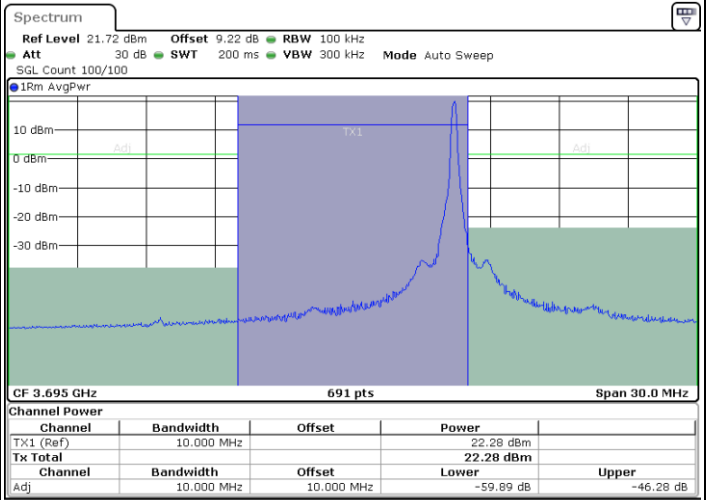

Date: 13.MAR.2024 04:25:21

Highest Channel / FullRB

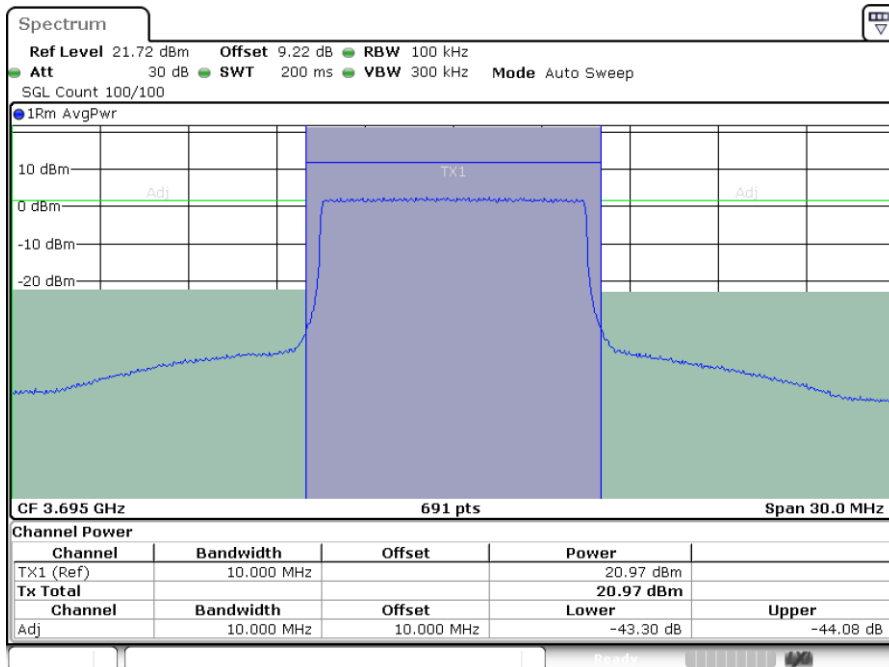

Date: 13.MAR.2024 04:28:37



LTE Band 48 / 10MHz

256QAM

Lowest Channel / 1RB0

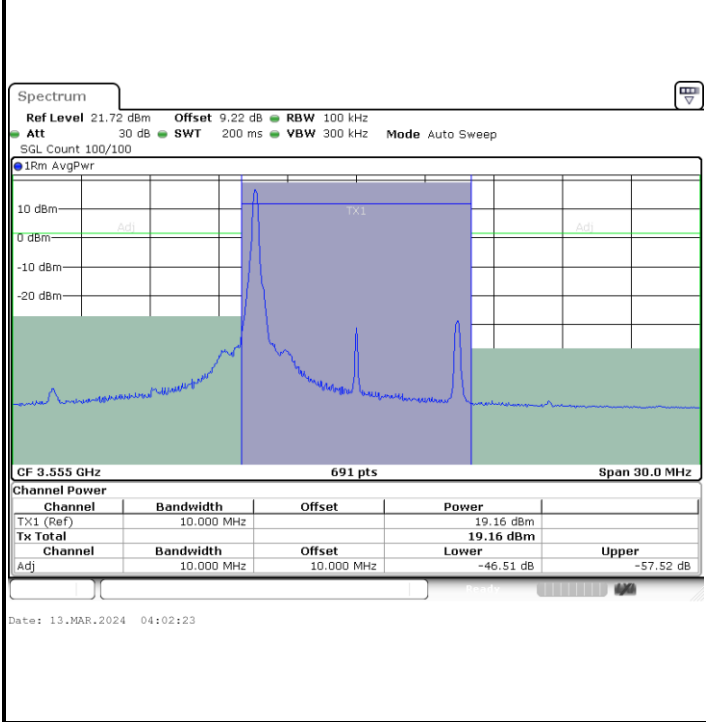

Lowest Channel / 1RBmax

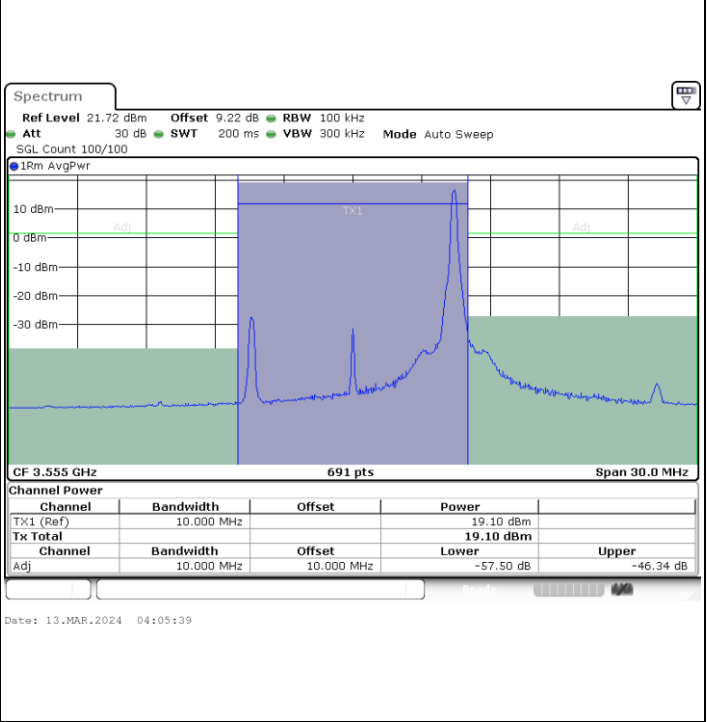

Lowest Channel / FullRB

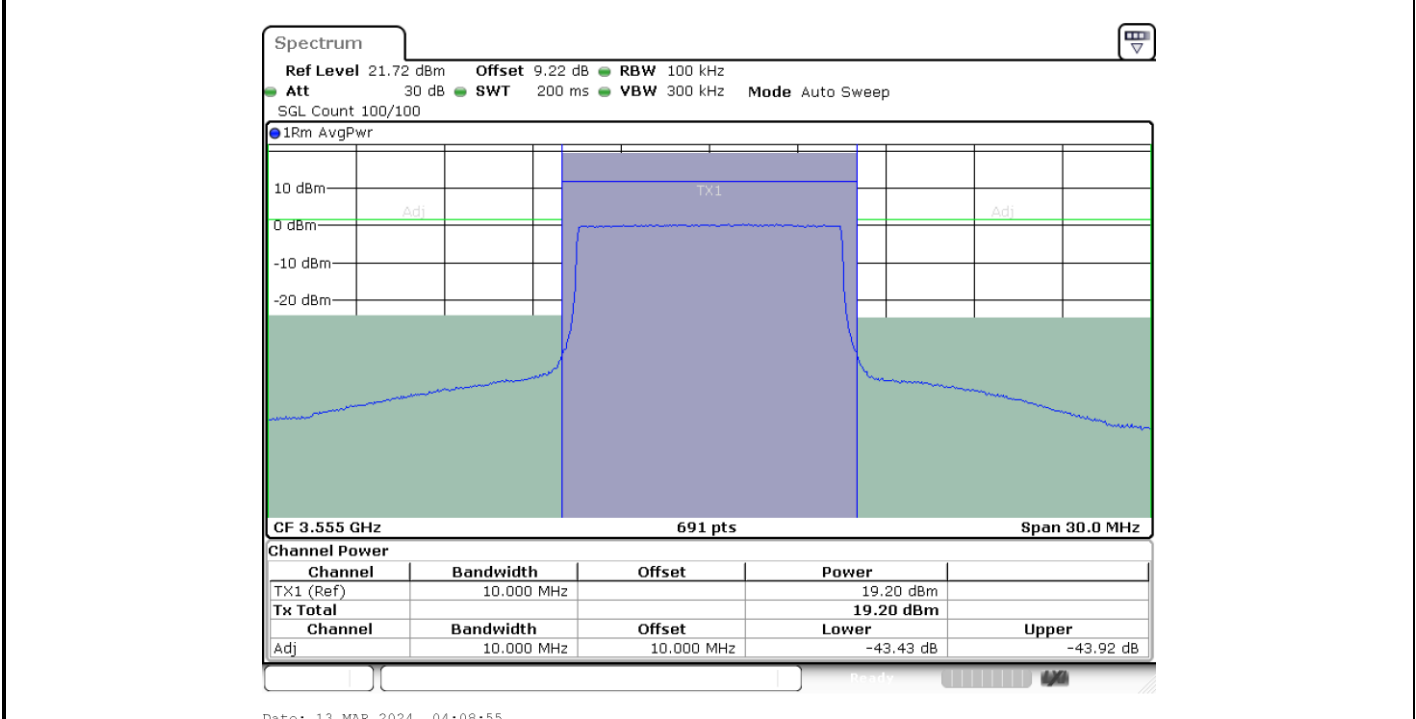



LTE Band 48 / 10MHz

256QAM

Middle Channel / 1RB0

Middle Channel / 1RBmax

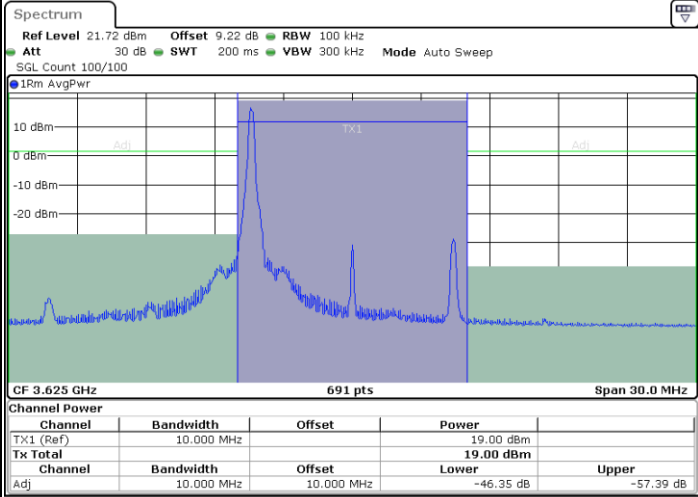

Date: 13.MAR.2024 04:13:13

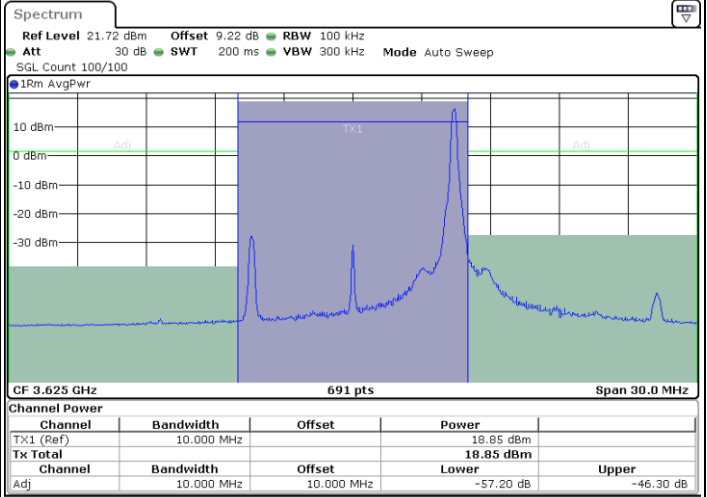

Date: 13.MAR.2024 04:16:25

Middle Channel / FullRB

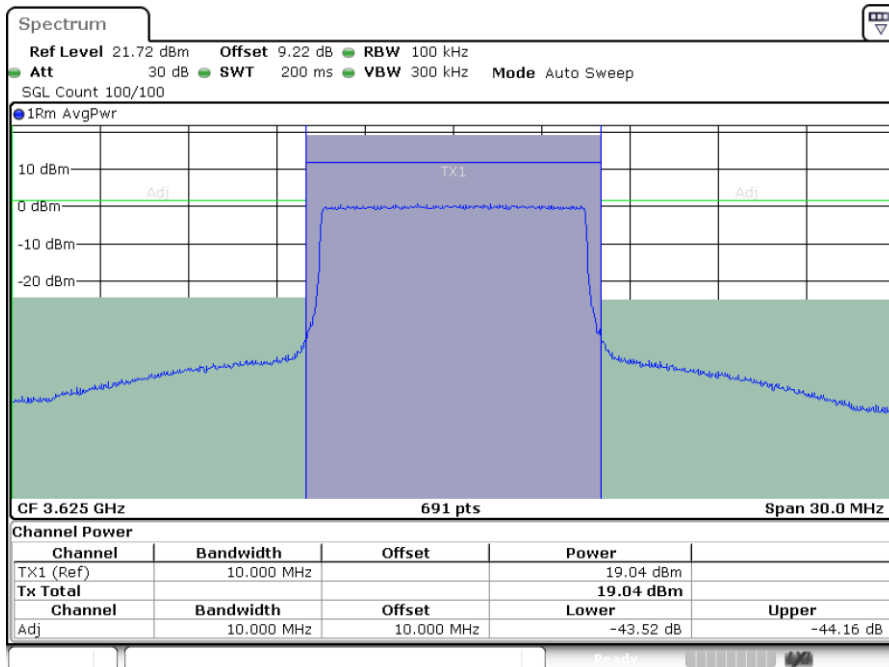

Date: 13.MAR.2024 04:19:39



LTE Band 48 / 10MHz

256QAM

Highest Channel / 1RB0

Highest Channel / 1RBmax

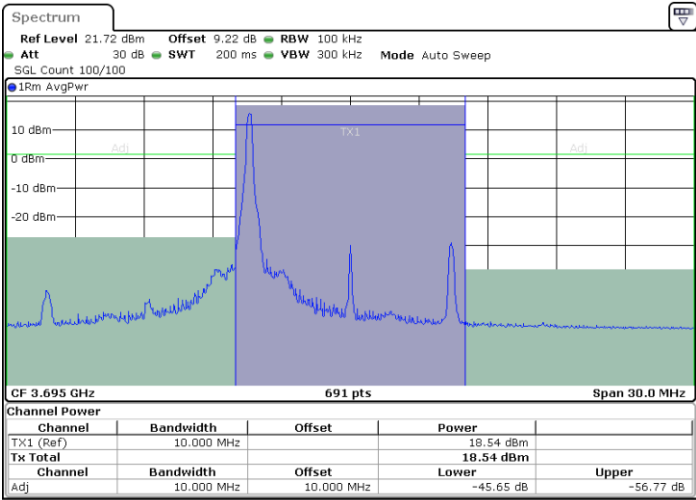

Date: 13.MAR.2024 04:22:53

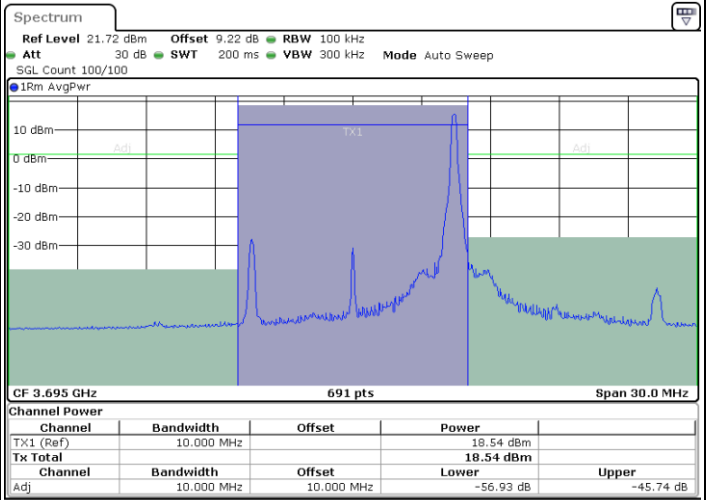

Date: 13.MAR.2024 04:26:09

Highest Channel / FullRB

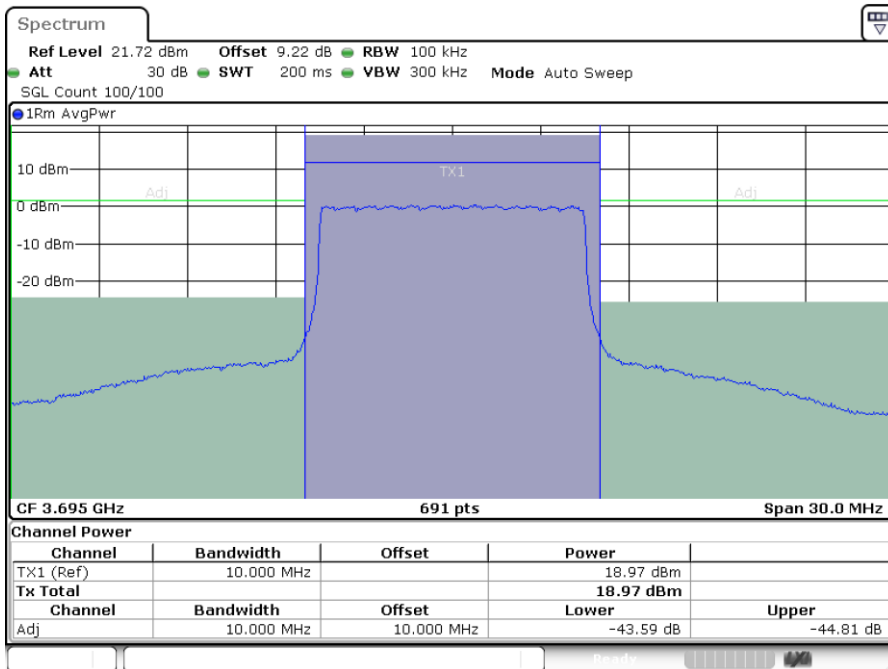

Date: 13.MAR.2024 04:29:29



LTE Band 48 / 15MHz

QPSK

Lowest Channel / 1RB0

Lowest Channel / 1RBmax

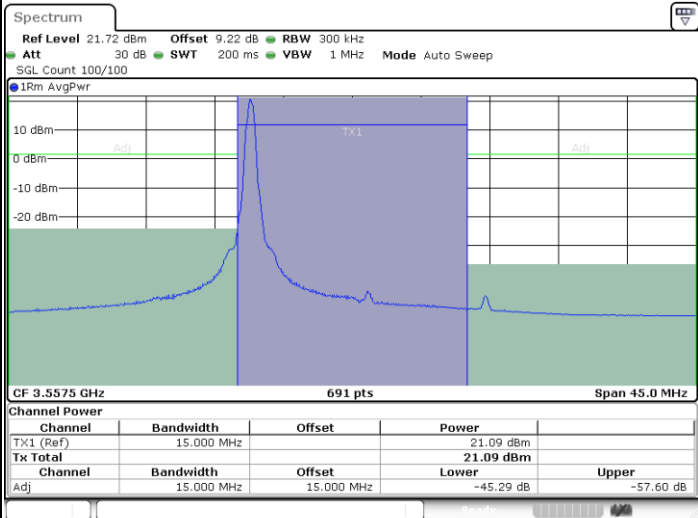

Date: 13.MAR.2024 04:30:52

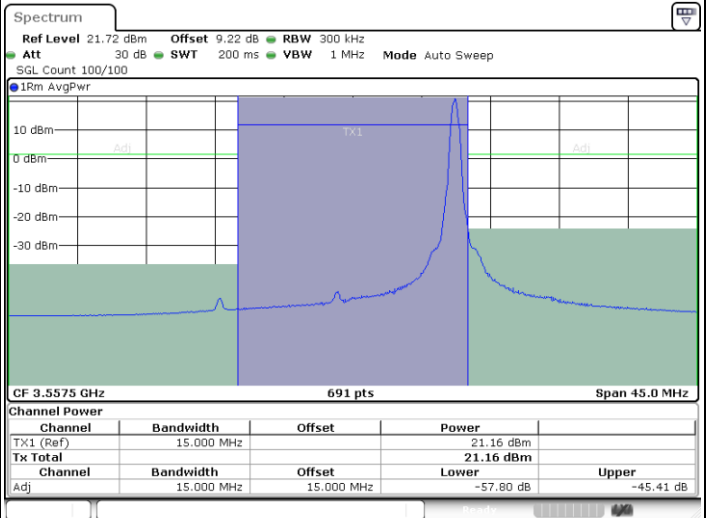

Date: 13.MAR.2024 04:34:02

Lowest Channel / FullIRB

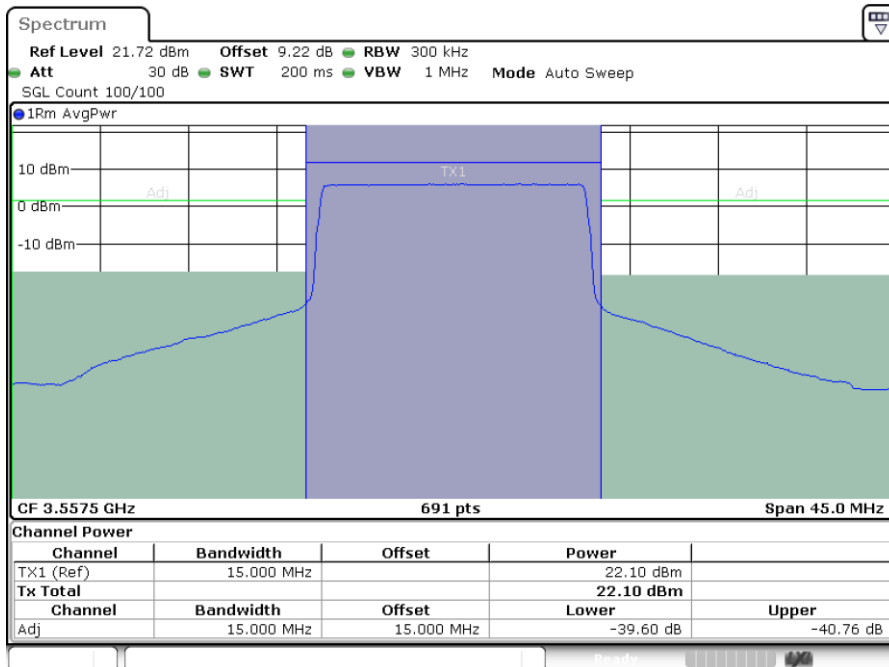

Date: 13.MAR.2024 04:37:12



LTE Band 48 / 15MHz

QPSK

Middle Channel / 1RB0

Middle Channel / 1RBmax

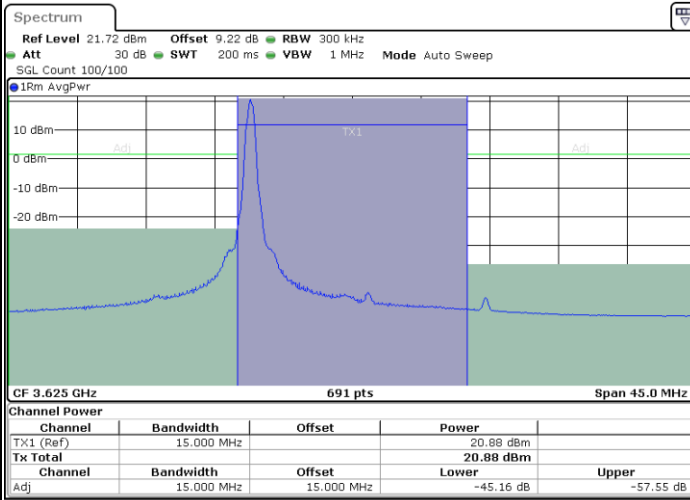

Date: 13.MAR.2024 04:41:21

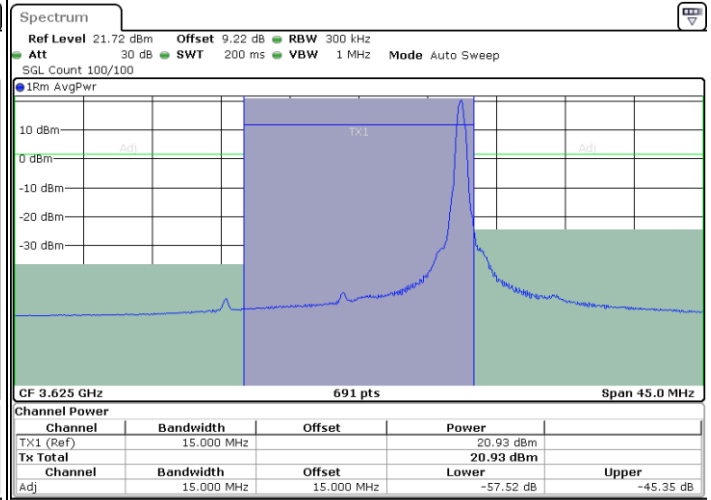

Date: 13.MAR.2024 04:44:26

Middle Channel / FullRB

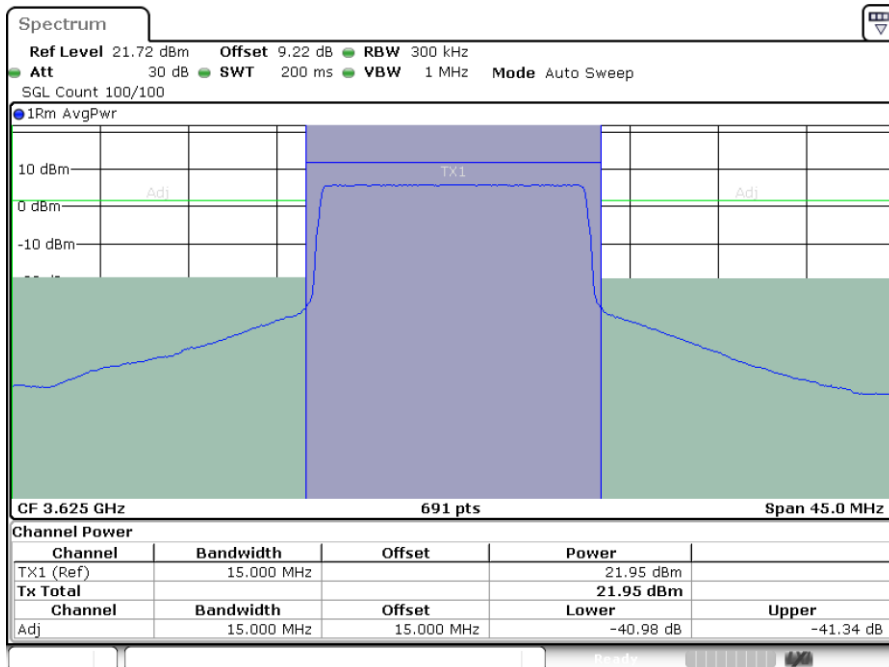

Date: 13.MAR.2024 04:47:35



LTE Band 48 / 15MHz

QPSK

Highest Channel / 1RB0

Highest Channel / 1RBmax

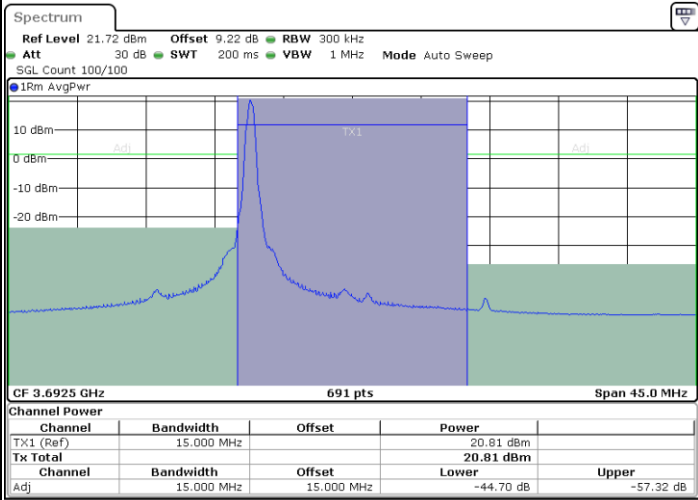

Date: 13.MAR.2024 04:50:39

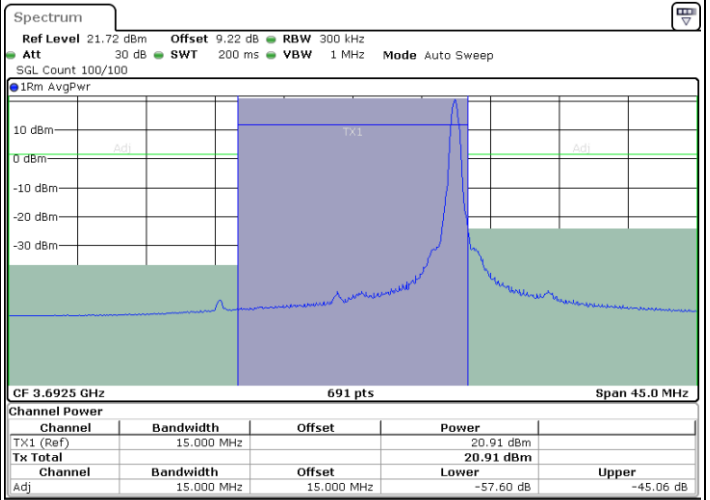

Date: 13.MAR.2024 04:53:47

Highest Channel / FullRB

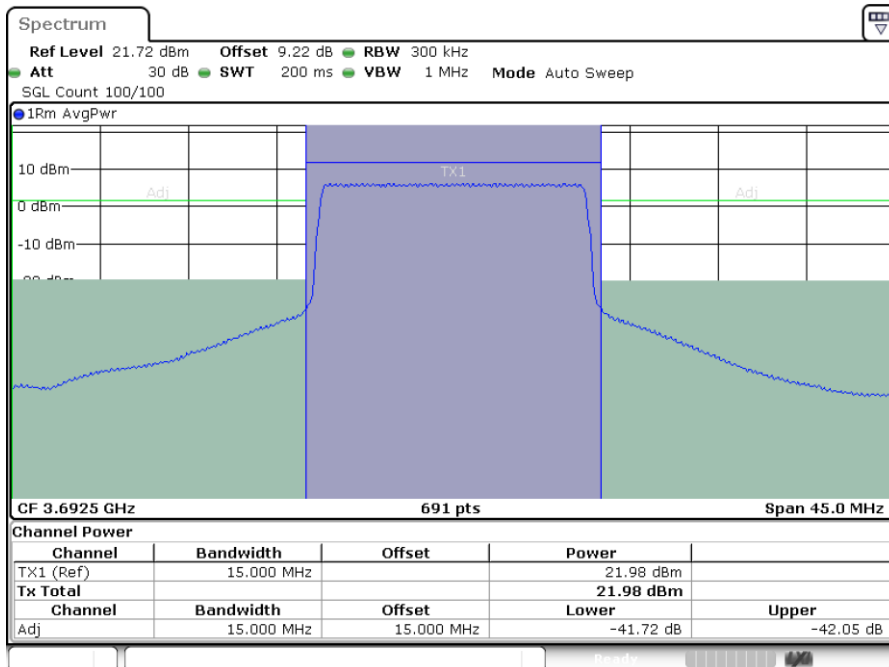

Date: 13.MAR.2024 04:56:58



LTE Band 48 / 15MHz

16QAM

Lowest Channel / 1RB0

Lowest Channel / 1RBmax

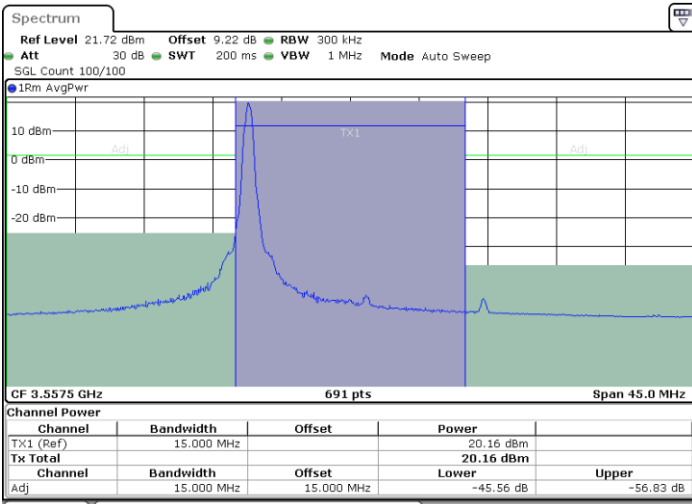

Date: 13.MAR.2024 04:31:39

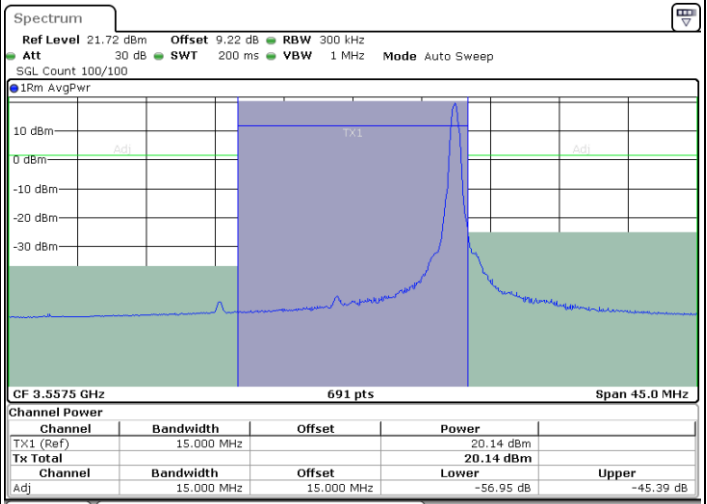

Date: 13.MAR.2024 04:34:50

Lowest Channel / FullRB

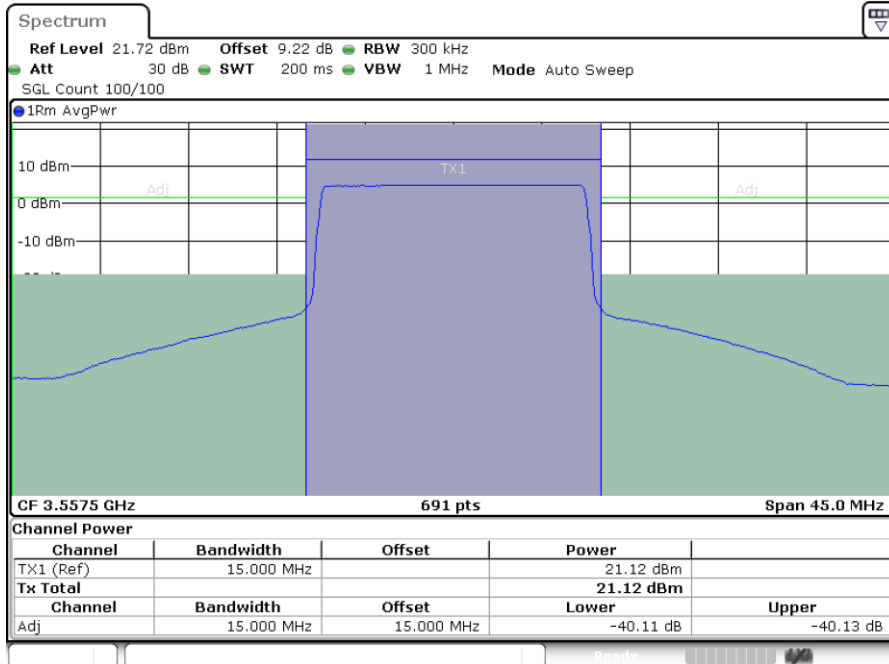

Date: 13.MAR.2024 04:37:57



LTE Band 48 / 15MHz

16QAM

Middle Channel / 1RB0

Middle Channel / 1RBmax

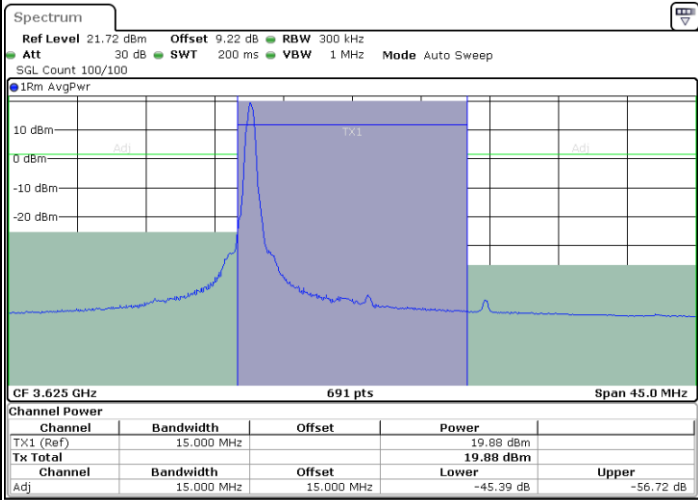

Date: 13.MAR.2024 04:42:07

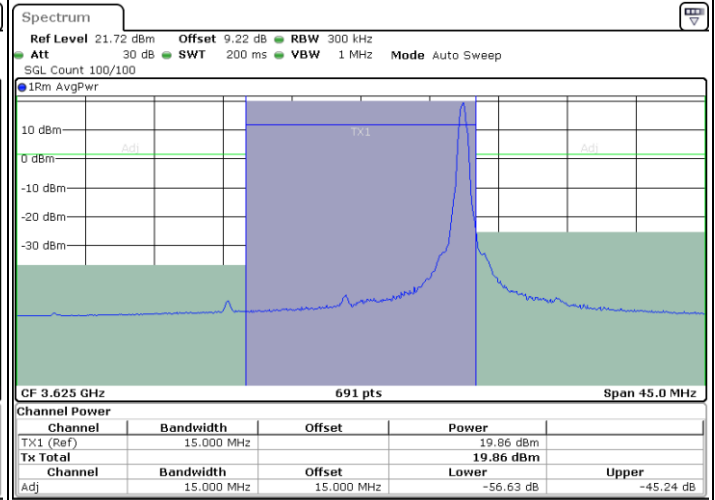

Date: 13.MAR.2024 04:45:15

Middle Channel / FullIRB

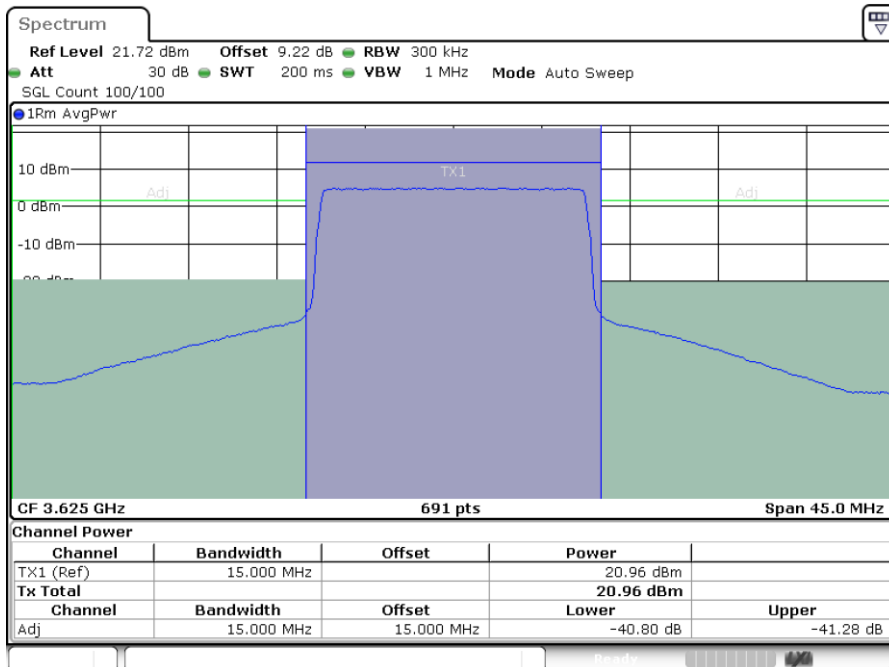

Date: 13.MAR.2024 04:48:20



LTE Band 48 / 15MHz

16QAM

Highest Channel / 1RB0

Highest Channel / 1RBmax

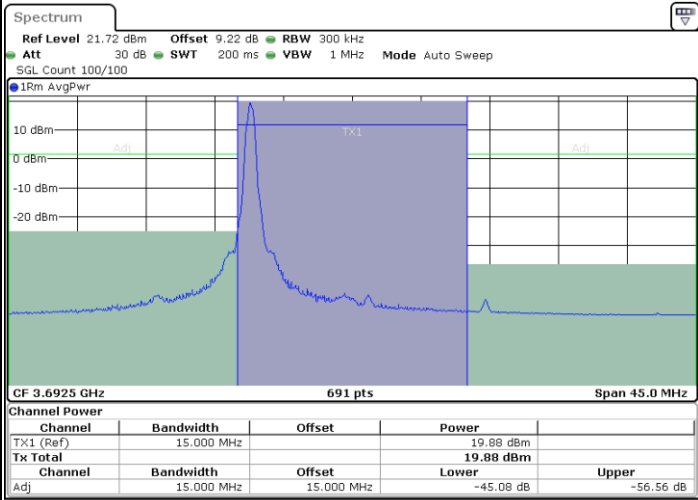

Date: 13.MAR.2024 04:51:25

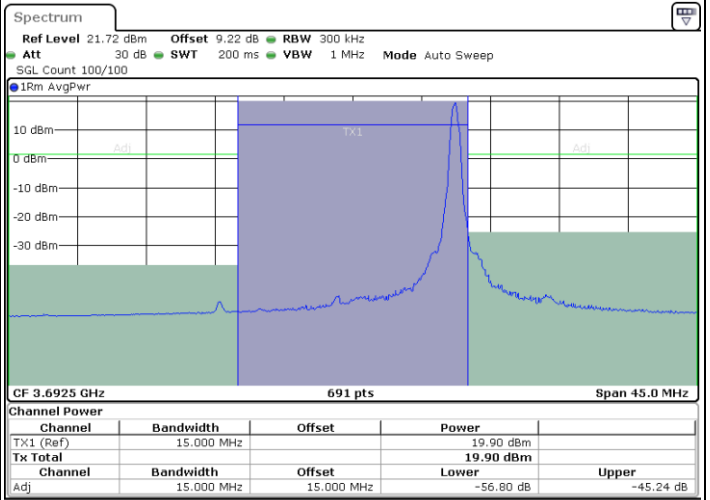

Date: 13.MAR.2024 04:54:36

Highest Channel / FullRB

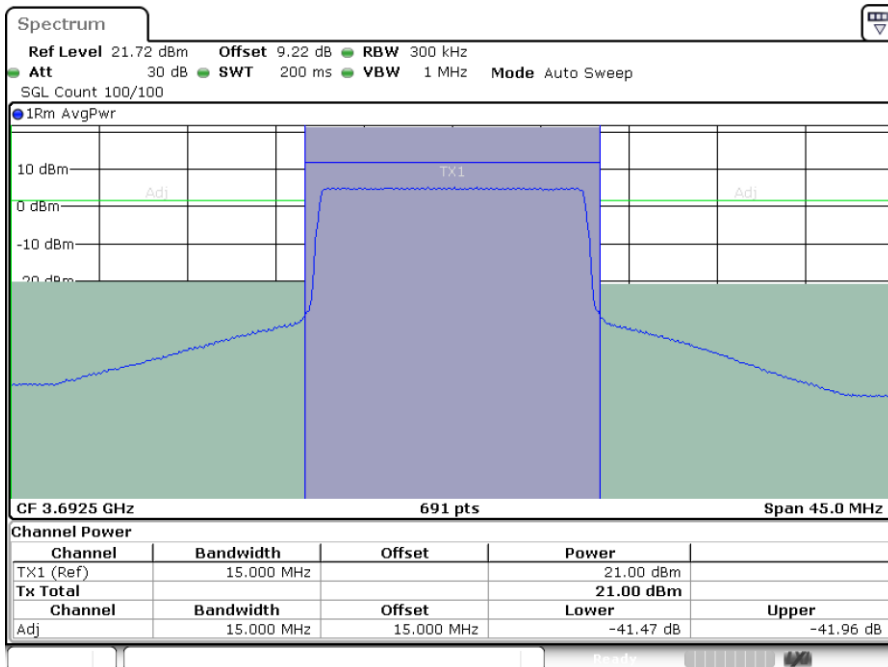

Date: 13.MAR.2024 04:57:43



LTE Band 48 / 15MHz

64QAM

Lowest Channel / 1RB0

Lowest Channel / 1RBmax

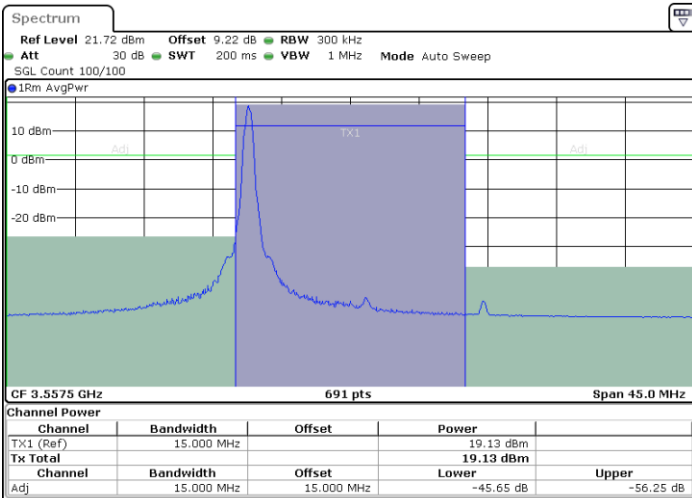

Date: 13.MAR.2024 04:32:28

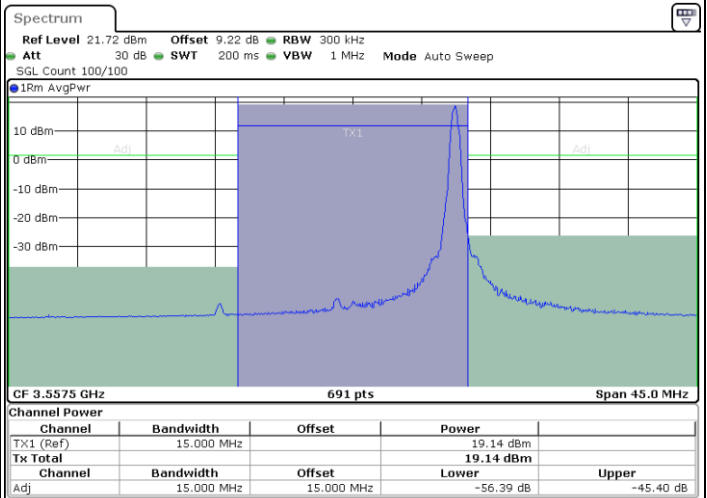

Date: 13.MAR.2024 04:35:36

Lowest Channel / FullRB

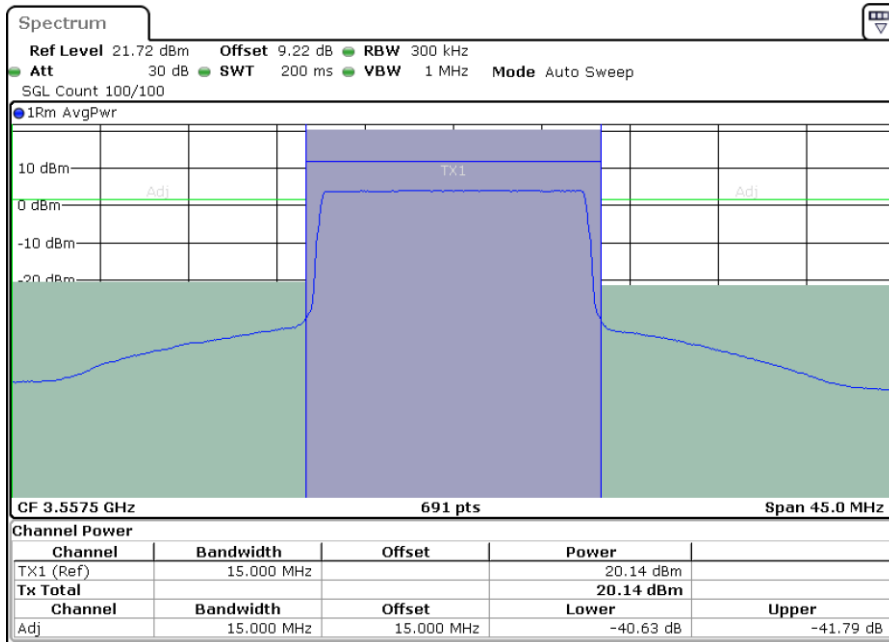

Date: 13.MAR.2024 04:38:43