

# FCC RF Test Report

APPLICANT : Xiaomi Communications Co., Ltd.  
EQUIPMENT : Mobile Phone  
BRAND NAME : POCO  
MODEL NAME : 24069PC21G  
FCC ID : 2AFZZPC21G  
STANDARD : 47 CFR Part 2, Part 27 Subpart Q  
CLASSIFICATION : PCS Licensed Transmitter Held to Ear (PCE)  
TEST DATE(S) : Feb. 27, 2024 ~ Mar. 04, 2024

We, Sporton International Inc. (Kunshan), would like to declare that the tested sample has been evaluated in accordance with the procedures given in ANSI C63.26-2015 and shown compliance with the applicable technical standards.

This report contains data that were produced under subcontract by Sporton International Inc. (ShenZhen).

The test results in this report apply exclusively to the tested model / sample. Without written approval of Sporton International Inc. (Kunshan), the test report shall not be reproduced except in full.

Jason Jia



Approved by: Jason Jia

**Sporton International Inc. (Kunshan)**

No. 1098, Pengxi North Road, Kunshan Economic Development Zone Jiangsu Province 215300  
People's Republic of China



TABLE OF CONTENTS

REVISION HISTORY..... 3
SUMMARY OF TEST RESULT ..... 4
1 GENERAL DESCRIPTION ..... 5
1.1 Applicant ..... 5
1.2 Manufacturer ..... 5
1.3 Product Feature of Equipment Under Test ..... 5
1.4 Product Specification of Equipment Under Test ..... 5
1.5 Modification of EUT ..... 6
1.6 Maximum EIRP Power and Emission Designator ..... 6
1.7 Testing Site ..... 7
1.8 Test Software ..... 8
1.9 Applied Standards ..... 8
2 TEST CONFIGURATION OF EQUIPMENT UNDER TEST ..... 9
2.1 Test Mode ..... 9
2.2 Connection Diagram of Test System ..... 10
2.3 Support Unit used in test configuration and system ..... 10
2.4 Measurement Results Explanation Example ..... 10
2.5 Frequency List of Low/Middle/High Channels ..... 11
3 CONDUCTED TEST ITEMS ..... 12
3.1 Measuring Instruments ..... 12
3.2 Test Setup ..... 12
3.3 Test Result of Conducted Test ..... 12
3.4 Conducted Output Power Measurement ..... 13
3.5 Peak-to-Average Ratio ..... 14
3.6 EIRP ..... 15
3.7 Occupied Bandwidth ..... 16
3.8 Conducted Band Edge Measurement ..... 17
3.9 Conducted Spurious Emission Measurement ..... 18
3.10 Frequency Stability Measurement ..... 19
4 RADIATED TEST ITEMS ..... 20
4.1 Measuring Instruments ..... 20
4.2 Test Setup ..... 20
4.3 Test Result of Radiated Test ..... 21
4.4 Radiated Spurious Emission Measurement ..... 22
5 LIST OF MEASURING EQUIPMENT ..... 23
6 MEASUREMENT UNCERTAINTY ..... 24
APPENDIX A. TEST RESULTS OF CONDUCTED TEST
APPENDIX B. TEST RESULTS OF RADIATED TEST
APPENDIX C. TEST SETUP PHOTOGRAPHS





### SUMMARY OF TEST RESULT

Report Section	FCC Rule	Description	Limit	Result	Remark
3.4	§2.1046	Conducted Output Power	—	Report Only	-
3.5	§27.50 (k)(4)	Peak-to-Average Ratio	<13dB	PASS	
3.6	§27.50 (k)(3)	EIRP	EIRP < 1W (30dBm)	PASS	-
3.7	§2.1049	Occupied Bandwidth	—	Report Only	-
3.8	§2.1051 §27.53 (n)(2)	Conducted Band Edge Measurement	-13dBm/MHz	PASS	-
3.9	§2.1051 §27.53 (n)(2)	Conducted Spurious Emission	-13dBm/MHz	PASS	-
3.10	§2.1055 §27.54	Frequency Stability Temperature & Voltage	Within the band	PASS	-
4.4	§2.1053 §27.53 (n)(2)	Radiated Spurious Emission	-13dBm/MHz	PASS	Under limit 39.34 dB at 10356.00 MHz

**Conformity Assessment Condition:**

- The test results (PASS/FAIL) with all measurement uncertainty excluded are presented against the regulation limits or in accordance with the requirements stipulated by the applicant/manufacturer who shall bear all the risks of non-compliance that may potentially occur if measurement uncertainty is taken into account.
- The measurement uncertainty please refer to each test result in the section "Measurement Uncertainty"

**Disclaimer:**

The product specifications of the EUT presented in the test report that may affect the test assessments are declared by the manufacturer who shall take full responsibility for the authenticity.

# 1 General Description

## 1.1 Applicant

Xiaomi Communications Co., Ltd.

#019, 9th Floor, Building 6, 33 Xi'erqi Middle Road, Haidian District, Beijing, China, 100085

## 1.2 Manufacturer

Xiaomi Communications Co., Ltd.

#019, 9th Floor, Building 6, 33 Xi'erqi Middle Road, Haidian District, Beijing, China, 100085

## 1.3 Product Feature of Equipment Under Test

Product Feature	
Equipment	Mobile Phone
Brand Name	POCO
Model Name	24069PC21G
FCC ID	2AFZZPC21G
IMEI Code	Conducted : 861593070021482/861593070021490 Radiation : 861593070015641/861593070015658
HW Version	1351N16T
SW Version	Xiaomi HyperOS 1.0
EUT Stage	Identical Prototype

Remark: The four model names are only for market segment, no other difference.

## 1.4 Product Specification of Equipment Under Test

Product Feature	
Tx/Rx Frequency	5G NR n77: 3450 MHz ~ 3550 MHz 5G NR n78: 3450 MHz ~ 3550 MHz
SCS	30kHz
Bandwidth	n77/n78(30kHz): 10 / 15 / 20 / 25 / 30 / 40 / 50 / 60 / 70 / 80 / 90 / 100MHz
Antenna Gain	<Ant. 1> 5G NR n77: -3.1 dBi 5G NR n78: -3.1 dBi <Ant. 6> 5G NR n77: -0.3 dBi 5G NR n78: -0.3 dBi <Ant. 7> 5G NR n77: -0.7 dBi 5G NR n78: -0.7 dBi <Ant. 8> 5G NR n77: -0.3 dBi 5G NR n78: -0.3 dBi
Type of Modulation	CP-OFDM: QPSK / 16QAM / 64QAM / 256QAM DFT-s-OFDM: PI/2 BPSK / QPSK / 16QAM / 64QAM / 256QAM

**Remark:**

1. The maximum EIRP is calculated from max output power and max antenna gain, only the maximum EIRP is shown in the report, 5G NR n77/n78 for Antenna 6.
2. The device supports n77/n78(1T4R) SRS resources on Antenna 1/6/7/8, only the test data of worst Antenna 6 is showed in the report according to the maximum power.
3. 5G NR n78 supports SA and NSA mode, n77 supports SA mode only. According to the maximum power between SA and NSA mode, SA covers NSA mode and 5G NR n77 covers n78.
4. The device supports HPUE mode for 5G NR n77/n78.
5. The EN-DC mode combination could be referred to the product spec.

### 1.5 Modification of EUT

No modifications are made to the EUT during all test items.

### 1.6 Maximum EIRP Power and Emission Designator

5G NR n77 SA for SCS 30kHz		PI/2 BPSK / QPSK		16QAM/64QAM/256QAM	
BW (MHz)	Frequency Range (MHz)	Maximum EIRP(W)	Emission Designator (99%OBW)	Maximum EIRP(W)	Emission Designator (99%OBW)
10	3455.01 ~ 3544.98	0.5012	8M56G7D	0.4102	8M58W7D
15	3457.50 ~ 3542.49	0.4875	13M6G7D	0.3926	13M6W7D
20	3460.02 ~ 3540.00	0.4966	18M2G7D	0.3926	18M3W7D
25	3462.51 ~ 3537.48	0.5035	23M2G7D	0.4036	23M3W7D
30	3465.00 ~ 3534.99	0.5105	27M8G7D	0.4064	27M9W7D
40	3470.01 ~ 3529.98	0.5117	37M9G7D	0.4027	37M9W7D
50	3475.02 ~ 3525.00	0.5284	47M6G7D	0.4150	47M6W7D
60	3480.00 ~ 3519.99	0.5070	57M9G7D	0.4009	57M9W7D
70	3485.01 ~ 3514.98	0.5297	67M5G7D	0.4140	67M6W7D
80	3490.02 ~ 3510.00	0.5236	77M5G7D	0.4198	77M5W7D
90	3495.00 ~ 3504.99	0.5358	87M3G7D	0.4217	87M5W7D
100	3500.01	0.5420	97M3G7D	0.4276	97M5W7D

5G NR n78 SA for SCS 30kHz		PI/2 BPSK / QPSK		16QAM/64QAM/256QAM	
BW (MHz)	Frequency Range (MHz)	Maximum EIRP(W)	Emission Designator (99%OBW)	Maximum EIRP(W)	Emission Designator (99%OBW)
10	3455.01 ~ 3544.98	0.4932	8M56G7D	0.3819	8M58W7D
15	3457.50 ~ 3542.49	0.4831	13M6G7D	0.3811	13M6W7D
20	3460.02 ~ 3540.00	0.4864	18M2G7D	0.3784	18M3W7D
25	3462.51 ~ 3537.48	0.4977	23M2G7D	0.3882	23M3W7D
30	3465.00 ~ 3534.99	0.5023	27M8G7D	0.3945	27M9W7D
40	3470.01 ~ 3529.98	0.4977	37M9G7D	0.3945	37M9W7D
50	3475.02 ~ 3525.00	0.5070	47M6G7D	0.4074	47M6W7D
60	3480.00 ~ 3519.99	0.4909	57M9G7D	0.3908	57M9W7D
70	3485.01 ~ 3514.98	0.5058	67M5G7D	0.4055	67M6W7D
80	3490.02 ~ 3510.00	0.5140	77M5G7D	0.4074	77M5W7D
90	3495.00 ~ 3504.99	0.5152	87MG37D	0.4121	87M5W7D
100	3500.01	0.5321	97M3G7D	0.4207	97M5W7D

**Note:**

1. 5G NR Band n77 overlaps the entire frequency range of Band n78, and n77 power > n78 power, therefore the conducted test results of n77 provided in this report cover n78.
2. All modulations have been tested, and only the worst test results of PSK & QAM are shown in the report.

### 1.7 Testing Site

Sporton International Inc. (Kunshan) is accredited to ISO/IEC 17025:2017 by American Association for Laboratory Accreditation with Certificate Number 5145.02.

<b>Test Firm</b>	Sporton International Inc. (Kunshan)		
<b>Test Site Location</b>	No. 1098, Pengxi North Road, Kunshan Economic Development Zone Jiangsu Province 215300 People's Republic of China TEL : +86-512-57900158		
<b>Test Site No.</b>	<b>Sporton Site No.</b>	<b>FCC Designation No.</b>	<b>FCC Test Firm Registration No.</b>
	03CH04-KS	CN1257	314309



Sporton International Inc. (ShenZhen) is accredited to ISO/IEC 17025:2017 by American Association for Laboratory Accreditation with Certificate Number 5145.01.

<b>Test Firm</b>	Sporton International Inc. (ShenZhen)		
<b>Test Site Location</b>	1/F, 2/F, Bldg 5, Shiling Industrial Zone, Xinwei Village, Xili, Nanshan, Shenzhen, 518055 People's Republic of China TEL: +86-755-86379589 FAX: +86-755-86379595		
<b>Test Site No.</b>	<b>Sporton Site No.</b>	<b>FCC Designation No.</b>	<b>FCC Test Firm Registration No.</b>
	TH01-SZ	CN1256	421272

**Note:** Test data subcontracted: conducted test case in section 3.4~3.10 of this report

### 1.8 Test Software

Item	Site	Manufacture	Name	Version
1.	03CH04-KS	AUDIX	E3	210616

### 1.9 Applied Standards

According to the specifications of the manufacturer, the EUT must comply with the requirements of the following standards:

- 47 CFR Part 2, Part 27 Subpart Q
- ANSI C63.26-2015
- FCC KDB 971168 Power Meas License Digital Systems D01 v03r01
- FCC KDB 412172 D01 Determining ERP and EIRP v01r01

**Remark:**

1. All test items were verified and recorded according to the standards and without any deviation during the test.
2. This EUT has also been tested and complied with the requirements of FCC Part 15, Subpart B, recorded in a separate test report.





## 2 Test Configuration of Equipment Under Test

### 2.1 Test Mode

Antenna port conducted and radiated test items listed below are performed according to KDB 971168 D01 Power Meas. License Digital Systems v03r01 with maximum output power.

Radiated measurements are performed by rotating the EUT in three different orthogonal test planes to find the maximum emission.

Test Cases	Band	Bandwidth (MHz)	Modulation	RB #	Test Channel
		eg. 5M, 10M, 15M, 20M	eg. PI/2 BPSK, QPSK, 16QAM, 64QAM, 256QAM	1RB, Partial RB, Full RB	L/M/H
Max. Output Power	5G n77	10M, 15M, 20M, 25M, 30M, 40M, 50M, 60M, 70M, 80M, 90M, 100M	All Modulations	1RB, Full RB	L, M, H
	5G n78	10M, 15M, 20M, 25M, 30M, 40M, 50M, 60M, 70M, 80M, 90M, 100M	All Modulations	1RB, Full RB	L, M, H
Peak-to-Average Ratio	5G n77	20M	PI/2 BPSK, QPSK	Full RB	M
E.I.R.P	5G n77	10M, 15M, 20M, 25M, 30M, 40M, 50M, 60M, 70M, 80M, 90M, 100M	All Modulations	1RB, Full RB	L, M, H
	5G n78	10M, 15M, 20M, 25M, 30M, 40M, 50M, 60M, 70M, 80M, 90M, 100M	All Modulations	1RB, Full RB	L, M, H
26dB and 99% Bandwidth	5G n77	10M, 15M, 20M, 25M, 30M, 40M, 50M, 60M, 70M, 80M, 90M, 100M	QPSK, 16QAM, 64QAM, 256QAM	Full RB	M
Conducted Band Edge	5G n77	10M, 50M, 100M	PI/2 BPSK, QPSK	1RB, Full RB	L, H
Conducted Spurious Emission	5G n77	10M, 50M, 100M	PI/2 BPSK, QPSK	1RB	L, M, H
Frequency Stability	5G n77	20M	QPSK	Full RB	M
Radiated Spurious Emission	5G n77	Worst case from maximum power			M
	5G n78	Worst case from maximum power			M

**Note:**

- The device is investigated from 30MHz to 10 times of fundamental signal for radiated spurious emission test under different RB size/offset and modulations in exploratory test. Subsequently, only the worst case emissions are reported.
- Frequency Stability: Normal Voltage = 3.91V ; Low Voltage =3.60V.; High Voltage =4.30V.
- All test items are based on engineering evaluation.

## 2.2 Connection Diagram of Test System

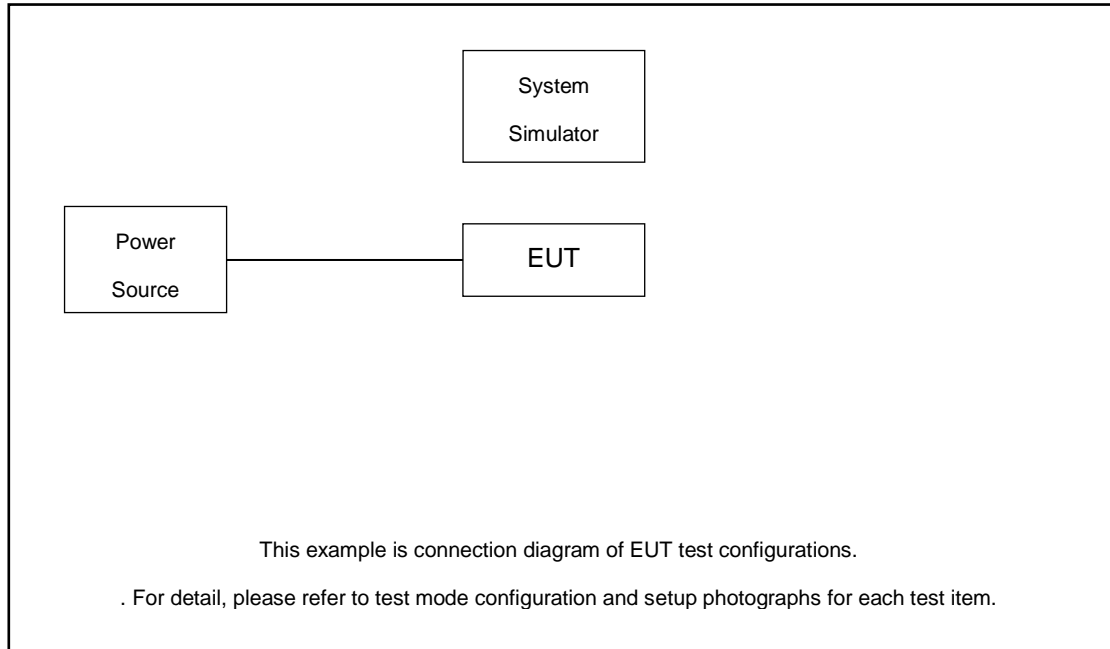

## 2.3 Support Unit used in test configuration and system

Item	Equipment	Trade Name	Model No.	FCC ID	Data Cable	Power Cord
1.	DC Power Supply	GW	GPS-3030D	N/A	N/A	Unshielded, 1.8 m
2.	LTE Base Station	Anritsu	MT8820C	N/A	N/A	Unshielded, 1.8 m
3.	NR Base Station	Anritsu	MT8000A	N/A	N/A	Unshielded, 1.8 m

## 2.4 Measurement Results Explanation Example

**For all conducted test items:**

The offset level is set in the spectrum analyzer to compensate the RF cable loss between EUT conducted output port and spectrum analyzer. With the offset compensation, the spectrum analyzer reading level is exactly the EUT RF output level.

The spectrum analyzer offset is derived from RF cable loss.

$$\text{Offset} = \text{RF cable loss.}$$

Following shows an offset computation example with cable loss 8.9dB.

Example :

$$\begin{aligned} \text{Offset(dB)} &= \text{RF cable loss(dB)}. \\ &= 8.9 \text{ (dB)} \end{aligned}$$

## 2.5 Frequency List of Low/Middle/High Channels

5G n77/n78 Channel and Frequency List for SCS 30kHz				
BW [MHz]	Channel/Frequency(MHz)	Lowest	Middle	Highest
100	Channel	-	633334	-
	Frequency	-	3500.01	-
90	Channel	633000	633334	633666
	Frequency	3495	3500.01	3504.99
80	Channel	632668	633334	634000
	Frequency	3490.02	3500.01	3510
70	Channel	632334	633334	634332
	Frequency	3485.01	3500.01	3514.98
60	Channel	632000	633334	634666
	Frequency	3480	3500.01	3519.99
50	Channel	631668	633334	635000
	Frequency	3475.02	3500.01	3525
40	Channel	631334	633334	635332
	Frequency	3470.01	3500.01	3529.98
30	Channel	631000	633334	635666
	Frequency	3465	3500.01	3534.99
25	Channel	630834	633334	635832
	Frequency	3462.51	3500.01	3537.48
20	Channel	630668	633334	636000
	Frequency	3460.02	3500.01	3540
15	Channel	630500	633334	636166
	Frequency	3457.5	3500.01	3542.49
10	Channel	630334	633334	636332
	Frequency	3455.01	3500.01	3544.98

### 3 Conducted Test Items

#### 3.1 Measuring Instruments

See list of measuring instruments of this test report.

#### 3.2 Test Setup

##### 3.2.1 Conducted Output Power

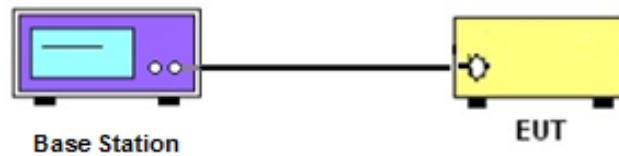

##### 3.2.2 Peak-to-Average Ratio, Occupied / 26dB Bandwidth, Band-Edge and Conducted Spurious Emission

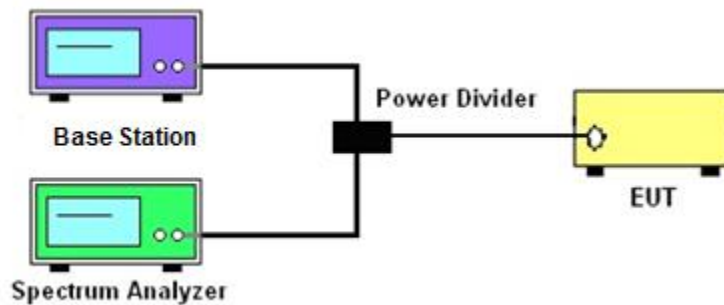

##### 3.2.3 Frequency Stability

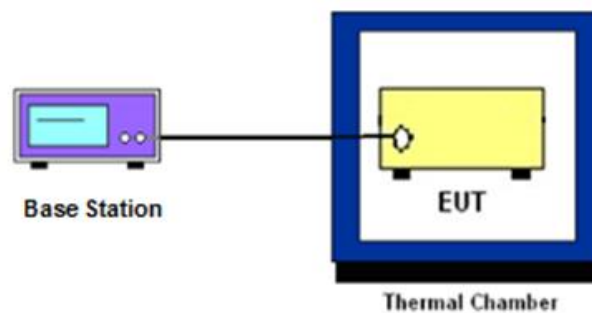

### 3.3 Test Result of Conducted Test

Please refer to Appendix A.



## **3.4 Conducted Output Power Measurement**

### **3.4.1 Description of the Conducted Output Power Measurement**

A base station simulator was used to establish communication with the EUT. Its parameters were set to transmit the maximum power on the EUT. The measured power in the radio frequency on the transmitter output terminals shall be reported.

### **3.4.2 Test Procedures**

1. The testing follows ANSI C63.26 Section 5.2
2. The transmitter output port was connected to the system simulator.
3. Set EUT at maximum power through the system simulator.
4. Select lowest, middle, and highest channels for each band and different modulation.
5. Measure and record the power level from the system simulator.

## 3.5 Peak-to-Average Ratio

### 3.5.1 Description of the PAR Measurement

Power Complementary Cumulative Distribution Function (CCDF) curves provide a means for characterizing the power peaks of a digitally modulated signal on a statistical basis. A CCDF curve depicts the probability of the peak signal amplitude exceeding the average power level. Most contemporary measurement instrumentation include the capability to produce CCDF curves for an input signal provided that the instrument's resolution bandwidth can be set wide enough to accommodate the entire input signal bandwidth. In measuring transmissions in this band using an average power technique, the peak-to-average ratio (PAR) of the transmission may not exceed 13 dB.

### 3.5.2 Test Procedures

1. The testing follows ANSI C63.26 Section 5.2.3.4 (CCDF).
2. The EUT was connected to spectrum and system simulator via a power divider.
3. Set the CCDF (Complementary Cumulative Distribution Function) option in spectrum analyzer.
4. The highest RF powers were measured and recorded the maximum PAPR level associated with a probability of 0.1 %.
5. Record the deviation as Peak to Average Ratio.

## 3.6 EIRP

### 3.6.1 Description of EIRP Limit

#### § 27.50 (k)(3)

Mobile devices are limited to 1Watt (30 dBm) EIRP. Mobile devices operating in these bands must employ a means for limiting power to the minimum necessary for successful communications

### 3.6.2 Test Procedures

1. According to KDB 412172 D01 Power Approach,
2.  $EIRP = P_T + G_T - L_C$ ,  $ERP = EIRP - 2.15$ , where  
 $P_T$  = transmitter output power in dBm  
 $G_T$  = gain of the transmitting antenna in dBi  
 $L_C$  = signal attenuation in the connecting cable between the transmitter and antenna in dB

## 3.7 Occupied Bandwidth

### 3.7.1 Description of Occupied Bandwidth Measurement

The occupied bandwidth is the width of a frequency band such that, below the lower and above the upper frequency limits, the mean powers emitted are each equal to a specified percentage 0.5% of the total mean transmitted power.

The 26 dB emission bandwidth is defined as the frequency range between two points, one above and one below the carrier frequency, at which the spectral density of the emission is attenuated 26 dB below the maximum in-band spectral density of the modulated signal. Spectral density (power per unit bandwidth) is to be measured with a detector of resolution bandwidth equal to approximately 1.0% of the emission bandwidth.

### 3.7.2 Test Procedures

1. The testing follows ANSI C63.26 Section 5.4
2. The EUT was connected to spectrum analyzer and system simulator via a power divider.
3. The spectrum analyzer center frequency is set to the nominal EUT channel center frequency. The span range for the spectrum analyzer shall be between two and five times the anticipated OBW.
4. The nominal resolution bandwidth (RBW) shall be in the range of 1 to 5 % of the anticipated OBW, and the VBW shall be at least 3 times the RBW.
5. Set the detection mode to peak, and the trace mode to max hold.
6. Determine the reference value: Set the EUT to transmit a modulated signal. Allow the trace to stabilize. Set the spectrum analyzer marker to the highest level of the displayed trace.  
(this is the reference value)
7. Determine the “-26 dB down amplitude” as equal to (Reference Value – X).
8. Place two markers, one at the lowest and the other at the highest frequency of the envelope of the spectral display such that each marker is at or slightly below the “-X dB down amplitude” determined in step 6. If a marker is below this “-X dB down amplitude” value it shall be placed as close as possible to this value. The OBW is the positive frequency difference between the two markers.
9. Use the 99 % power bandwidth function of the spectrum analyzer and report the measured bandwidth.



## 3.8 Conducted Band Edge Measurement

### 3.8.1 Description of Conducted Band Edge Measurement

#### § 27.53 (n)(2)

For mobile operations in the 3450-3550 MHz band, the conducted power of any emission outside the licensee's authorized bandwidth shall not exceed  $-13$  dBm/MHz.

Compliance with this paragraph is based on the use of measurement instrumentation employing a resolution bandwidth of 1 megahertz or greater. However, in the 1 megahertz bands immediately outside and adjacent to the licensee's frequency block, a resolution bandwidth of at least one percent of the emission bandwidth of the fundamental emission of the transmitter may be employed, but limited to a maximum of 200 kHz. In the bands between 1 and 5 MHz removed from the licensee's frequency block, the minimum resolution bandwidth for the measurement shall be 500 kHz.

### 3.8.2 Test Procedures

1. The testing follows ANSI C63.26 section 5.7
2. The EUT was connected to spectrum analyzer and system simulator via a power divider.
3. The band edges of low and high channels for the highest RF powers were measured.
4. Set RBW  $\geq 1\%$  EBW but limited to a maximum of 200 kHz in the 1MHz band immediately outside and adjacent to the band edge.
5. Beyond the 1 MHz and 5 MHz removed from the band edge, set RBW  $\geq 500$ KHz.
6. Beyond the 5 MHz removed from the band edge, set RBW = 1MHz.
7. Set spectrum analyzer with RMS detector.
8. The RF fundamental frequency should be excluded against the limit line in the operating frequency band.
9. Checked that all the results comply with the emission limit line.

## 3.9 Conducted Spurious Emission Measurement

### 3.9.1 Description of Conducted Spurious Emission Measurement

The power of any emission outside of the authorized operating frequency ranges shall not exceed  $-13$  dBm/MHz.

It is measured by means of a calibrated spectrum analyzer and scanned from 9 kHz up to a frequency including its 10<sup>th</sup> harmonic.

### 3.9.2 Test Procedures

1. The testing follows ANSI C63.26 section 5.7
2. The EUT was connected to spectrum analyzer and system simulator via a power divider.
3. The RF output of EUT was connected to the spectrum analyzer by RF cable and attenuator. The path loss was compensated to the results for each measurement.
4. The middle channel for the highest RF power within the transmitting frequency was measured.
5. The conducted spurious emission for the whole frequency range was taken.
6. Make the measurement with the spectrum analyzer's RBW = 1MHz, VBW = 3MHz.
7. Set spectrum analyzer with RMS detector.
8. Taking the record of maximum spurious emission.
9. The RF fundamental frequency should be excluded against the limit line in the operating frequency band.
10. Checked that all the results comply with the emission limit line.

## 3.10 Frequency Stability Measurement

### 3.10.1 Description of Frequency Stability Measurement

The frequency stability shall be measured by variation of ambient temperature and variation of primary supply voltage to ensure that the fundamental emission stays within the authorized frequency block.

### 3.10.2 Test Procedures for Temperature Variation

1. The testing follows ANSI C63.26 section 5.6.4
2. The EUT was set up in the thermal chamber and connected with the system simulator.
3. With power OFF, the temperature was decreased to  $-30^{\circ}\text{C}$  and the EUT was stabilized before testing. Power was applied and the maximum change in frequency was recorded within one minute.
4. With power OFF, the temperature was raised in  $10^{\circ}\text{C}$  step up to  $50^{\circ}\text{C}$ . The EUT was stabilized at each step for at least half an hour. Power was applied and the maximum frequency change was recorded within one minute.

### 3.10.3 Test Procedures for Voltage Variation

1. The testing follows ANSI C63.26 section 5.6.5.
2. The EUT was placed in a temperature chamber at  $20\pm 5^{\circ}\text{C}$  and connected with the system simulator.
3. The power supply voltage to the EUT was varied from 85% to 115% of the nominal value for other than hand carried battery equipment.
4. For hand carried, battery powered equipment, reduce the primary ac or dc supply voltage to the battery operating end point, which shall be specified by the manufacturer.
5. The variation in frequency was measured for the worst case.

## 4 Radiated Test Items

### 4.1 Measuring Instruments

See list of measuring instruments of this test report.

### 4.2 Test Setup

#### 4.2.1 For radiated test below 30MHz

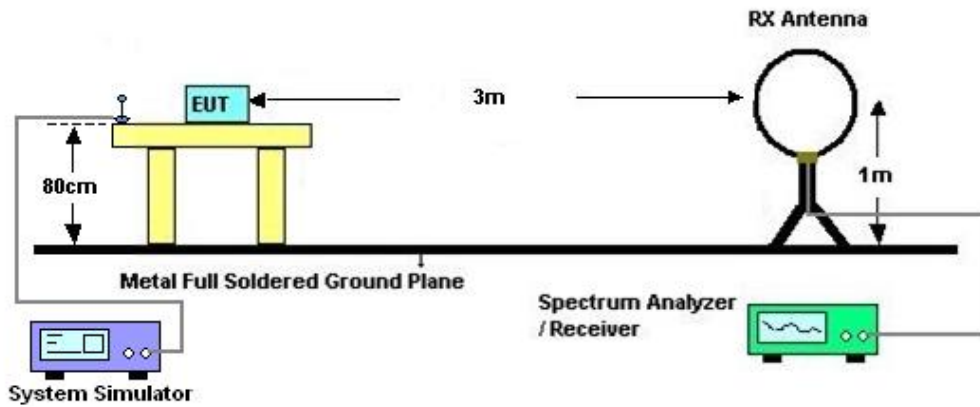

#### 4.2.2 For radiated test from 30MHz to 1GHz

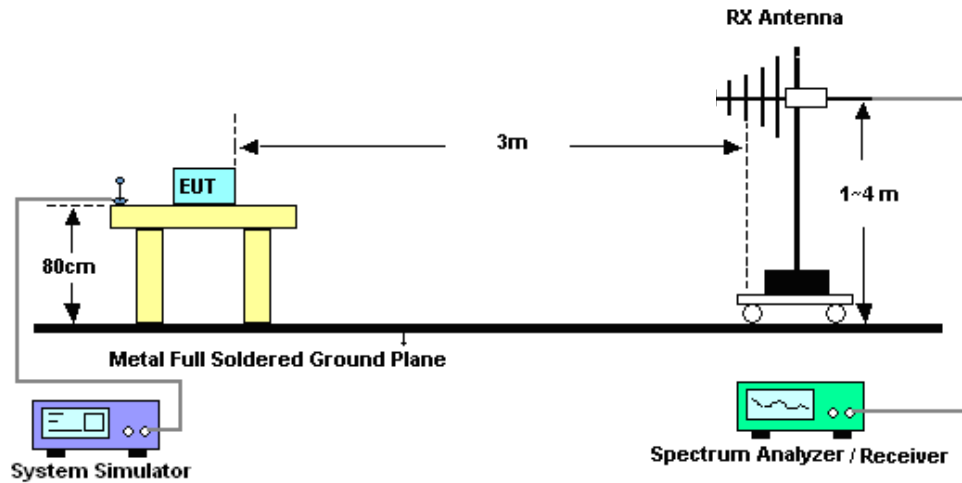

### 4.2.3 For radiated test above 1GHz

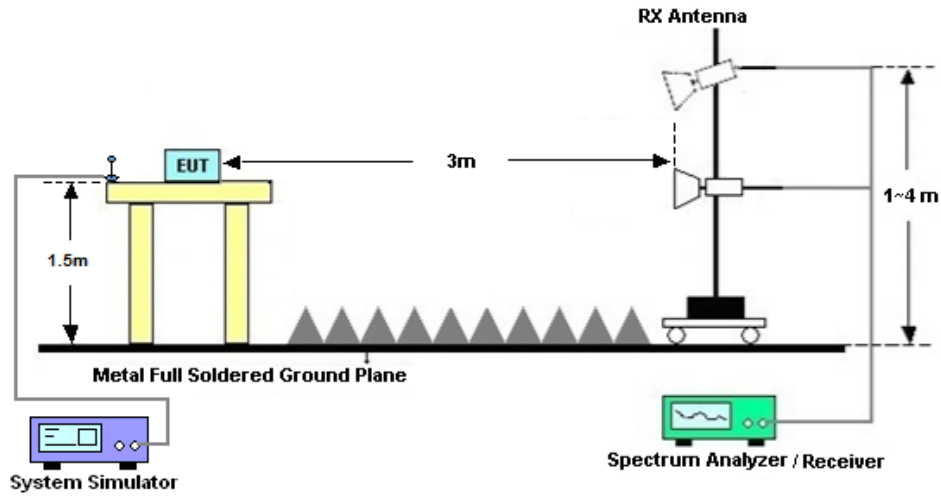

### 4.3 Test Result of Radiated Test

The low frequency, which started from 9 kHz to 30MHz, was pre-scanned and the result which was 20dB lower than the limit line was not reported.

Please refer to Appendix B.

## 4.4 Radiated Spurious Emission Measurement

### 4.4.1 Description of Radiated Spurious Emission

The radiated spurious emission was measured by substitution method according to ANSI/TIA-603-E. The power of any emission outside of the authorized operating frequency ranges shall not exceed -13 dBm/MHz.

The spectrum is scanned from 30 MHz up to a frequency including its 10th harmonic.

### 4.4.2 Test Procedures

1. The testing follows ANSI C63.26 Section 5.5
2. The EUT was placed on a turntable with 0.8 meter height for frequency below 1GHz and 1.5 meter height for frequency above 1GHz respectively above ground.
3. The EUT was set 3 meters from the receiving antenna mounted on the antenna tower.
4. The table was rotated 360 degrees to determine the position of the highest spurious emission.
5. The height of the receiving antenna is varied between 1m to 4m to search the maximum spurious emission for both horizontal and vertical polarizations.
6. During the measurement, the system simulator parameters were set to force the EUT transmitting at maximum output power.
7. Make the measurement with the spectrum analyzer's RBW = 1MHz, VBW = 3MHz, taking the record of maximum spurious emission.
8. A horn antenna was substituted in place of the EUT and was driven by a signal generator.
9. Tune the output power of signal generator to the same emission level with EUT maximum spurious emission.  
$$\text{EIRP (dBm)} = \text{S.G. Power} - \text{Tx Cable Loss} + \text{Tx Antenna Gain}$$
$$\text{ERP (dBm)} = \text{EIRP} - 2.15$$
10. The RF fundamental frequency should be excluded against the limit line in the operating frequency band.



## 5 List of Measuring Equipment

Instrument	Manufacturer	Model No.	Serial No.	Characteristics	Calibration Date	Test Date	Due Date	Remark
EXA Spectrum Analyzer	KEYSIGHT	N9010A	MY55150213	10Hz~44GHz	Jul. 07, 2023	Feb. 27, 2024~ Feb. 28, 2024	Jul. 06, 2024	Conducted (TH01-SZ)
DC Power Supply	TTI	PL330P	290070	Max 32V , 3A	Oct. 16, 2023	Feb. 27, 2024~ Feb. 28, 2024	Oct. 15, 2024	Conducted (TH01-SZ)
Power Divider	TOJOIN	PS-2SM-04 265	60.06.020.007 7	0.4GHz~26.5GHz	Dec. 25, 2023	Feb. 27, 2024~ Feb. 28, 2024	Dec. 24, 2024	Conducted (TH01-SZ)
Thermal Chamber	Ten Billion Hongzhangroup	LP-150U	H2014081803	-40~+150°C	Jul. 05, 2023	Feb. 27, 2024~ Feb. 28, 2024	Jul. 04, 2024	Conducted (TH01-SZ)
EXA Spectrum Analyzer	Keysight	N9010B	MY57471079	10Hz-44G,MAX 30dB	Oct. 10, 2023	Mar. 04, 2024	Oct. 09, 2024	Radiation (03CH04-KS)
Loop Antenna	R&S	HFH2-Z2E	101125	9kHz~30MHz	Sep. 11 2023	Mar. 04, 2024	Sep. 10, 2024	Radiation (03CH04-KS)
Bilog Antenna	TeseQ	CBL6111D	49922	30MHz-1GHz	Apr. 09, 2023	Mar. 04, 2024	Apr. 08, 2024	Radiation (03CH04-KS)
Double Ridge Horn Antenna	ETS-Lindgren	3117	00251694	1GHz~18GHz	Jul. 12, 2023	Mar. 04, 2024	Jul. 11, 2024	Radiation (03CH04-KS)
SHF-EHF Horn	Com-power	AH-840	101070	18GHz~40GHz	Jan. 05, 2024	Mar. 04, 2024	Jan. 04, 2025	Radiation (03CH04-KS)
Amplifier	SONOMA	310N	380827	9KHz-1GHz	Jul. 06, 2023	Mar. 04, 2024	Jul. 05, 2024	Radiation (03CH04-KS)
Amplifier	MITEQ	EM18G40G GA	060728	18~40GHz	Jan. 05, 2024	Mar. 04, 2024	Jan. 04, 2025	Radiation (03CH04-KS)
high gain Amplifier	EM	EM01G18G A	060840	1Ghz-18Ghz	Oct. 10, 2023	Mar. 04, 2024	Oct. 09, 2024	Radiation (03CH04-KS)
Amplifier	Agilent	8449B	3008A02370	1Ghz-18Ghz	Oct. 10, 2023	Mar. 04, 2024	Oct. 09, 2024	Radiation (03CH04-KS)
AC Power Source	Chroma	61601	F104090004	N/A	NCR	Mar. 04, 2024	NCR	Radiation (03CH04-KS)
Turn Table	ChamPro	EM 1000-T	060762-T	0~360 degree	NCR	Mar. 04, 2024	NCR	Radiation (03CH04-KS)
Antenna Mast	ChamPro	EM 1000-A	060762-A	1 m~4 m	NCR	Mar. 04, 2024	NCR	Radiation (03CH04-KS)

NCR: No Calibration Required

## 6 Measurement Uncertainty

The measurement uncertainties shown below were calculated in accordance with the requirements of ANSI 63.26-2015. All the measurement uncertainty value were shown with a coverage K=2 to indicate 95% level of confidence. The measurement data show herein meets or exceeds the CISPR measurement uncertainty values specified in CISPR 16-4-2 and can be compared directly to specified limit to determine compliance.

### Uncertainty of Conducted Measurement

Test Item	Uncertainty
Conducted Spurious Emission & Bandedge	±1.34 dB
Occupied Channel Bandwidth	±0.012 MHz
Conducted Power	±1.34 dB
Peak to Average Ratio	±1.34 dB
Frequency Stability	±1.3 ppm

### Uncertainty of Radiated Emission Measurement (30 MHz ~ 1000 MHz)

Measuring Uncertainty for a Level of Confidence of 95% (U = 2Uc(y))	3.82dB
---	--------

### Uncertainty of Radiated Emission Measurement (1 GHz ~ 18 GHz)

Measuring Uncertainty for a Level of Confidence of 95% (U = 2Uc(y))	3.56dB
---	--------

### Uncertainty of Radiated Emission Measurement (18 GHz ~ 40 GHz)

Measuring Uncertainty for a Level of Confidence of 95% (U = 2Uc(y))	3.54dB
---	--------

----- THE END -----





## Appendix A. Test Results of Conducted Test

Test Engineer :	Khan Zheng	Temperature :	22~23°C
		Relative Humidity :	40~42%

# FR1 N77 (Ant 6)

## Transmitter Conducted Output Power And EIRP, (G<sub>T</sub> - L<sub>C</sub>)=-0.3dB

NR Band	SCS (kHz)	Bandwidth (MHz)	Arfcn	Freq (MHz)	Modulation	RB	Conducted Power(dBm)	EIRP (dBm)	EIRP (W)
77	30	10	630334	3455.01	DFT-s-OFDM QPSK	1@1	27.24	26.94	0.4943
77	30	10	630334	3455.01	DFT-s-OFDM 16 QAM	1@1	26.3	26	0.3981
77	30	10	633334	3500.01	DFT-s-OFDM QPSK	1@1	27.3	27	0.5012
77	30	10	633334	3500.01	DFT-s-OFDM 16 QAM	1@1	26.43	26.13	0.4102
77	30	10	636332	3544.98	DFT-s-OFDM QPSK	1@1	27.22	26.92	0.4920
77	30	10	636332	3544.98	DFT-s-OFDM 16 QAM	1@1	26.29	25.99	0.3972
77	30	15	630500	3457.5	DFT-s-OFDM QPSK	1@1	27.11	26.81	0.4797
77	30	15	630500	3457.5	DFT-s-OFDM 16 QAM	1@1	26.2	25.9	0.3890
77	30	15	633334	3500.01	DFT-s-OFDM QPSK	1@1	27.15	26.85	0.4842
77	30	15	633334	3500.01	DFT-s-OFDM 16 QAM	1@1	26.17	25.87	0.3864
77	30	15	636166	3542.49	DFT-s-OFDM QPSK	1@1	27.18	26.88	0.4875
77	30	15	636166	3542.49	DFT-s-OFDM 16 QAM	1@1	26.24	25.94	0.3926
77	30	20	630668	3460.02	DFT-s-OFDM QPSK	1@1	27.18	26.88	0.4875
77	30	20	630668	3460.02	DFT-s-OFDM 16 QAM	1@1	26.2	25.9	0.3890
77	30	20	633334	3500.01	DFT-s-OFDM QPSK	1@1	27.26	26.96	0.4966
77	30	20	633334	3500.01	DFT-s-OFDM 16 QAM	1@1	26.24	25.94	0.3926
77	30	20	636000	3540	DFT-s-OFDM QPSK	1@1	27.06	26.76	0.4742
77	30	20	636000	3540	DFT-s-OFDM 16 QAM	1@1	26.06	25.76	0.3767
77	30	25	630834	3462.51	DFT-s-OFDM QPSK	1@1	27.31	27.01	0.5023
77	30	25	630834	3462.51	DFT-s-OFDM 16 QAM	1@1	26.31	26.01	0.3990
77	30	25	633334	3500.01	DFT-s-OFDM QPSK	1@1	27.11	26.81	0.4797
77	30	25	633334	3500.01	DFT-s-OFDM 16 QAM	1@1	26.36	26.06	0.4036
77	30	25	635832	3537.48	DFT-s-OFDM QPSK	1@1	27.32	27.02	0.5035
77	30	25	635832	3537.48	DFT-s-OFDM 16 QAM	1@1	26.31	26.01	0.3990
77	30	30	631000	3465	DFT-s-OFDM QPSK	1@1	27.36	27.06	0.5082
77	30	30	631000	3465	DFT-s-OFDM 16 QAM	1@1	26.38	26.08	0.4055
77	30	30	633334	3500.01	DFT-s-OFDM QPSK	1@1	27.37	27.07	0.5093
77	30	30	633334	3500.01	DFT-s-OFDM 16 QAM	1@1	26.38	26.08	0.4055
77	30	30	635666	3534.99	DFT-s-OFDM QPSK	1@1	27.38	27.08	0.5105

77	30	30	635666	3534.99	DFT-s-OFDM 16 QAM	1@1	26.39	26.09	0.4064
77	30	40	631334	3470.01	DFT-s-OFDM QPSK	1@1	27.31	27.01	0.5023
77	30	40	631334	3470.01	DFT-s-OFDM 16 QAM	1@1	26.35	26.05	0.4027
77	30	40	633334	3500.01	DFT-s-OFDM QPSK	1@1	27.39	27.09	0.5117
77	30	40	633334	3500.01	DFT-s-OFDM 16 QAM	1@1	26.3	26	0.3981
77	30	40	635332	3529.98	DFT-s-OFDM QPSK	1@1	27.24	26.94	0.4943
77	30	40	635332	3529.98	DFT-s-OFDM 16 QAM	1@1	26.29	25.99	0.3972
77	30	50	631668	3475.02	DFT-s-OFDM QPSK	1@1	27.43	27.13	0.5164
77	30	50	631668	3475.02	DFT-s-OFDM 16 QAM	1@1	26.48	26.18	0.4150
77	30	50	633334	3500.01	DFT-s-OFDM QPSK	1@1	27.53	27.23	0.5284
77	30	50	633334	3500.01	DFT-s-OFDM 16 QAM	1@1	26.46	26.16	0.4130
77	30	50	635000	3525	DFT-s-OFDM QPSK	1@1	27.47	27.17	0.5212
77	30	50	635000	3525	DFT-s-OFDM 16 QAM	1@1	26.48	26.18	0.4150
77	30	60	632000	3480	DFT-s-OFDM QPSK	1@1	27.24	26.94	0.4943
77	30	60	632000	3480	DFT-s-OFDM 16 QAM	1@1	26.3	26	0.3981
77	30	60	633334	3500.01	DFT-s-OFDM QPSK	1@1	27.35	27.05	0.5070
77	30	60	633334	3500.01	DFT-s-OFDM 16 QAM	1@1	26.3	26	0.3981
77	30	60	634666	3519.99	DFT-s-OFDM QPSK	1@1	27.32	27.02	0.5035
77	30	60	634666	3519.99	DFT-s-OFDM 16 QAM	1@1	26.33	26.03	0.4009
77	30	70	632334	3485.01	DFT-s-OFDM QPSK	1@1	27.45	27.15	0.5188
77	30	70	632334	3485.01	DFT-s-OFDM 16 QAM	1@1	26.31	26.01	0.3990
77	30	70	633334	3500.01	DFT-s-OFDM QPSK	1@1	27.54	27.24	0.5297
77	30	70	633334	3500.01	DFT-s-OFDM 16 QAM	1@1	26.38	26.08	0.4055
77	30	70	634332	3514.98	DFT-s-OFDM QPSK	1@1	27.47	27.17	0.5212
77	30	70	634332	3514.98	DFT-s-OFDM 16 QAM	1@1	26.47	26.17	0.4140
77	30	80	632668	3490.02	DFT-s-OFDM QPSK	1@1	27.18	26.88	0.4875
77	30	80	632668	3490.02	DFT-s-OFDM 16 QAM	1@1	26.39	26.09	0.4064
77	30	80	633334	3500.01	DFT-s-OFDM QPSK	1@1	27.49	27.19	0.5236
77	30	80	633334	3500.01	DFT-s-OFDM 16 QAM	1@1	26.53	26.23	0.4198
77	30	80	634000	3510	DFT-s-OFDM QPSK	1@1	27.48	27.18	0.5224
77	30	80	634000	3510	DFT-s-OFDM 16 QAM	1@1	26.51	26.21	0.4178
77	30	90	633000	3495	DFT-s-OFDM QPSK	1@1	27.44	27.14	0.5176
77	30	90	633000	3495	DFT-s-OFDM 16 QAM	1@1	26.48	26.18	0.4150
77	30	90	633334	3500.01	DFT-s-OFDM QPSK	1@1	27.48	27.18	0.5224
77	30	90	633334	3500.01	DFT-s-OFDM 16 QAM	1@1	26.55	26.25	0.4217

77	30	90	633666	3504.99	DFT-s-OFDM QPSK	1@1	27.59	27.29	0.5358
77	30	90	633666	3504.99	DFT-s-OFDM 16 QAM	1@1	26.55	26.25	0.4217
77	30	100	633334	3500.01	DFT-s-OFDM PI/2 BPSK	135@67	27.29	26.99	0.5000
77	30	100	633334	3500.01	DFT-s-OFDM PI/2 BPSK	1@1	27.6	27.3	0.5370
77	30	100	633334	3500.01	DFT-s-OFDM PI/2 BPSK	1@271	27.17	26.87	0.4864
77	30	100	633334	3500.01	DFT-s-OFDM QPSK	135@67	27.23	26.93	0.4932
77	30	100	633334	3500.01	DFT-s-OFDM QPSK	1@1	27.64	27.34	0.5420
77	30	100	633334	3500.01	DFT-s-OFDM QPSK	1@271	27.15	26.85	0.4842
77	30	100	633334	3500.01	DFT-s-OFDM 16 QAM	135@67	26.22	25.92	0.3908
77	30	100	633334	3500.01	DFT-s-OFDM 16 QAM	1@1	26.61	26.31	0.4276
77	30	100	633334	3500.01	DFT-s-OFDM 16 QAM	1@271	26.18	25.88	0.3873
77	30	100	633334	3500.01	DFT-s-OFDM 64 QAM	135@67	24.75	24.45	0.2786
77	30	100	633334	3500.01	DFT-s-OFDM 64 QAM	1@1	25.1	24.8	0.3020
77	30	100	633334	3500.01	DFT-s-OFDM 64 QAM	1@271	24.46	24.16	0.2606
77	30	100	633334	3500.01	DFT-s-OFDM 256 QAM	135@67	22.79	22.49	0.1774
77	30	100	633334	3500.01	DFT-s-OFDM 256 QAM	1@1	22.89	22.59	0.1816
77	30	100	633334	3500.01	DFT-s-OFDM 256 QAM	1@271	22.42	22.12	0.1629
77	30	100	633334	3500.01	CP-OFDM QPSK	137@68	25.65	25.35	0.3428
77	30	100	633334	3500.01	CP-OFDM QPSK	1@1	26.08	25.78	0.3784
77	30	100	633334	3500.01	CP-OFDM QPSK	1@271	25.65	25.35	0.3428

## Frequency Stability

NR Band	SCS (kHz)	Bandwidth (MHz)	Arfcn	Freq (MHz)	Modulation	RB	Deviation (ppm)	Verdict	Environment
77	30	20	633334	3500.01	DFT-s-OFDM QPSK	50@0	0.0033	PASS	NV
77	30	20	633334	3500.01	DFT-s-OFDM QPSK	50@0	0.0053	PASS	LV
77	30	20	633334	3500.01	DFT-s-OFDM QPSK	50@0	0.0029	PASS	HV
77	30	20	633334	3500.01	DFT-s-OFDM QPSK	50@0	0.0048	PASS	-30°C
77	30	20	633334	3500.01	DFT-s-OFDM QPSK	50@0	0.0054	PASS	-20°C
77	30	20	633334	3500.01	DFT-s-OFDM QPSK	50@0	0.0023	PASS	-10°C
77	30	20	633334	3500.01	DFT-s-OFDM QPSK	50@0	0.0048	PASS	0°C
77	30	20	633334	3500.01	DFT-s-OFDM QPSK	50@0	0.0024	PASS	10°C
77	30	20	633334	3500.01	DFT-s-OFDM QPSK	50@0	0.0033	PASS	20°C
77	30	20	633334	3500.01	DFT-s-OFDM QPSK	50@0	0.0057	PASS	30°C
77	30	20	633334	3500.01	DFT-s-OFDM QPSK	50@0	0.0054	PASS	40°C
77	30	20	633334	3500.01	DFT-s-OFDM QPSK	50@0	0.0028	PASS	50°C

# Peak to Average Ratio

NR Band	SCS (kHz)	Bandwidth (MHz)	Arfcn	Freq (MHz)	Modulation	RB	Result (dB)	Limit (dB)	Verdict
77	30	20	633334	3500.01	DFT-s-OFDM PI/2 BPSK	50@0	3.78	13	PASS
77	30	20	633334	3500.01	DFT-s-OFDM QPSK	50@0	4.42	13	PASS

N77(20M)\_DFT-s-OFDM\_PI\_2-BPSK\_Outer\_Full\_Mid\_CH

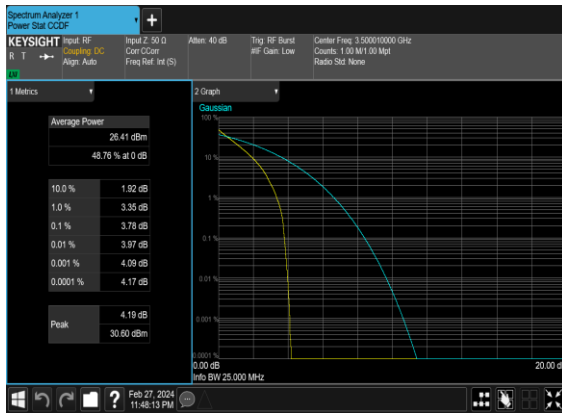

N77(20M)\_DFT-s-OFDM\_QPSK\_Outer\_Full\_Mid\_CH

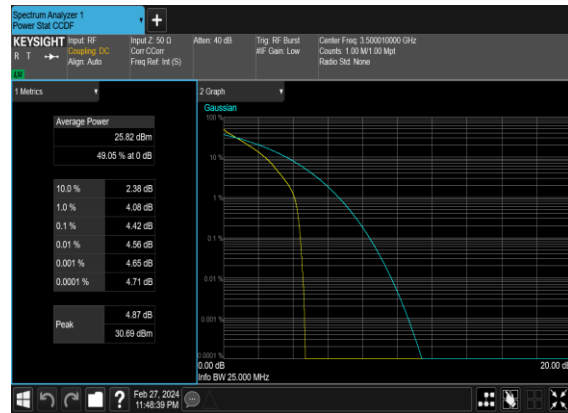

## Occupied Bandwidth

NR Band	SCS (kHz)	Bandwidth (MHz)	Arfcn	Freq (MHz)	Modulation	RB	OBW (MHz)	26dB BW (MHz)
77	30	10	633334	3500.01	CP-OFDM QPSK	24@0	8.5588	9.797
77	30	10	633334	3500.01	CP-OFDM 16 QAM	24@0	8.5791	9.447
77	30	10	633334	3500.01	CP-OFDM 64 QAM	24@0	8.5446	9.584
77	30	10	633334	3500.01	CP-OFDM 256 QAM	24@0	8.5652	9.483
77	30	15	633334	3500.01	CP-OFDM QPSK	38@0	13.579	14.72
77	30	15	633334	3500.01	CP-OFDM 16 QAM	38@0	13.604	14.57
77	30	15	633334	3500.01	CP-OFDM 64 QAM	38@0	13.54	14.53
77	30	15	633334	3500.01	CP-OFDM 256 QAM	38@0	13.566	14.46
77	30	20	633334	3500.01	CP-OFDM QPSK	51@0	18.188	19.35
77	30	20	633334	3500.01	CP-OFDM 16 QAM	51@0	18.256	19.02
77	30	20	633334	3500.01	CP-OFDM 64 QAM	51@0	18.161	19.56
77	30	20	633334	3500.01	CP-OFDM 256 QAM	51@0	18.198	19.55
77	30	25	633334	3500.01	CP-OFDM QPSK	65@0	23.174	24.37
77	30	25	633334	3500.01	CP-OFDM 16 QAM	65@0	23.267	24.46
77	30	25	633334	3500.01	CP-OFDM 64 QAM	65@0	23.246	24.32
77	30	25	633334	3500.01	CP-OFDM 256 QAM	65@0	23.224	24.48
77	30	30	633334	3500.01	CP-OFDM QPSK	78@0	27.802	29.05
77	30	30	633334	3500.01	CP-OFDM 16 QAM	78@0	27.8	29.36
77	30	30	633334	3500.01	CP-OFDM 64 QAM	78@0	27.908	29.3
77	30	30	633334	3500.01	CP-OFDM 256 QAM	78@0	27.938	28.98
77	30	40	633334	3500.01	CP-OFDM QPSK	106@0	37.937	39.26
77	30	40	633334	3500.01	CP-OFDM 16 QAM	106@0	37.927	39.32
77	30	40	633334	3500.01	CP-OFDM 64 QAM	106@0	37.839	39.68
77	30	40	633334	3500.01	CP-OFDM 256 QAM	106@0	37.772	39.49
77	30	50	633334	3500.01	CP-OFDM QPSK	133@0	47.578	49.17

77	30	50	633334	3500.01	CP-OFDM 16 QAM	133@0	47.312	49.25
77	30	50	633334	3500.01	CP-OFDM 64 QAM	133@0	47.602	49.21
77	30	50	633334	3500.01	CP-OFDM 256 QAM	133@0	47.485	49.52
77	30	60	633334	3500.01	CP-OFDM QPSK	162@0	57.859	59.73
77	30	60	633334	3500.01	CP-OFDM 16 QAM	162@0	57.823	59.85
77	30	60	633334	3500.01	CP-OFDM 64 QAM	162@0	57.912	59.76
77	30	60	633334	3500.01	CP-OFDM 256 QAM	162@0	57.633	59.91
77	30	70	633334	3500.01	CP-OFDM QPSK	189@0	67.5	69.74
77	30	70	633334	3500.01	CP-OFDM 16 QAM	189@0	67.521	69.68
77	30	70	633334	3500.01	CP-OFDM 64 QAM	189@0	67.59	69.85
77	30	70	633334	3500.01	CP-OFDM 256 QAM	189@0	67.326	69.73
77	30	80	633334	3500.01	CP-OFDM QPSK	217@0	77.522	79.96
77	30	80	633334	3500.01	CP-OFDM 16 QAM	217@0	77.483	80.14
77	30	80	633334	3500.01	CP-OFDM 64 QAM	217@0	77.534	79.97
77	30	80	633334	3500.01	CP-OFDM 256 QAM	217@0	77.449	79.94
77	30	90	633334	3500.01	CP-OFDM QPSK	245@0	87.329	90.33
77	30	90	633334	3500.01	CP-OFDM 16 QAM	245@0	87.356	90.28
77	30	90	633334	3500.01	CP-OFDM 64 QAM	245@0	87.411	90.3
77	30	90	633334	3500.01	CP-OFDM 256 QAM	245@0	87.523	90.33
77	30	100	633334	3500.01	CP-OFDM QPSK	273@0	97.33	100.6
77	30	100	633334	3500.01	CP-OFDM 16 QAM	273@0	97.535	100.5
77	30	100	633334	3500.01	CP-OFDM 64 QAM	273@0	97.41	100.4
77	30	100	633334	3500.01	CP-OFDM 256 QAM	273@0	97.442	100.5



### N77(10M)\_CP-OFDM\_QPSK\_Outer\_Full\_Mid\_CH

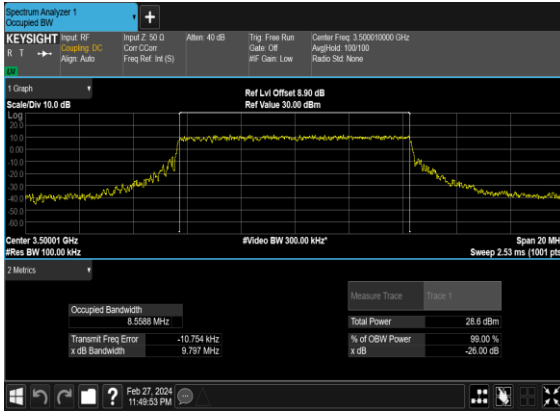

### N77(10M)\_CP-OFDM\_16QAM\_Outer\_Full\_Mid\_CH



### N77(10M)\_CP-OFDM\_64QAM\_Outer\_Full\_Mid\_CH

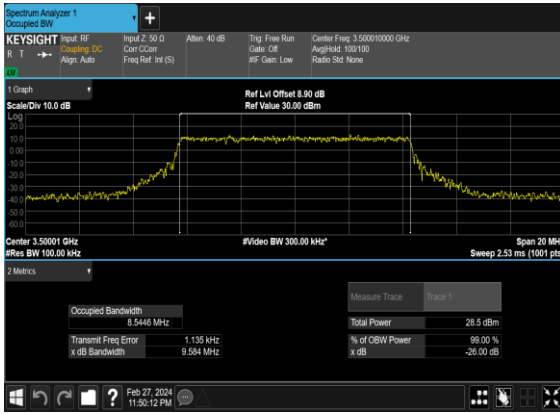

### N77(10M)\_CP-OFDM\_256QAM\_Outer\_Full\_Mid\_CH

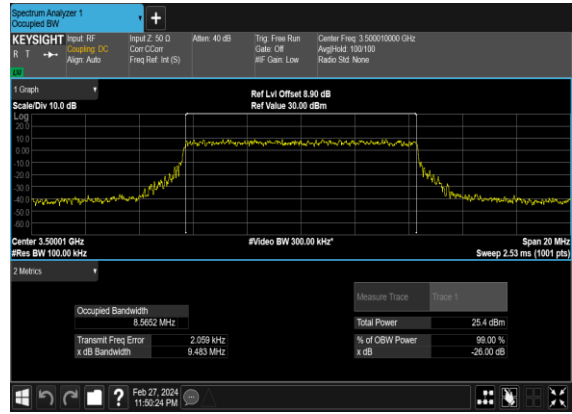

### N77(15M)\_CP-OFDM\_QPSK\_Outer\_Full\_Mid\_CH

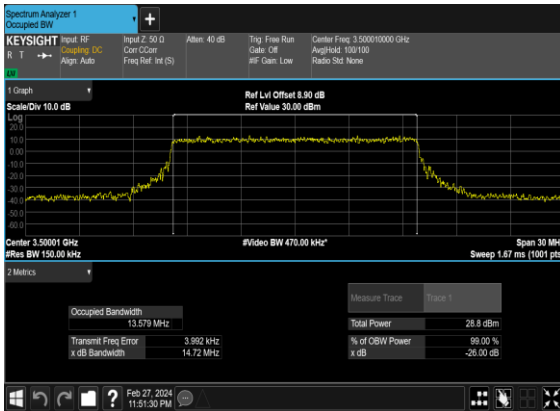

### N77(15M)\_CP-OFDM\_16QAM\_Outer\_Full\_Mid\_CH

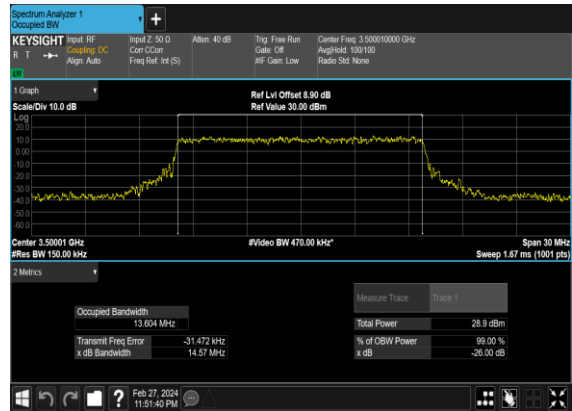

### N77(15M)\_CP-OFDM\_64 QAM\_Outer\_Full\_Mid\_CH

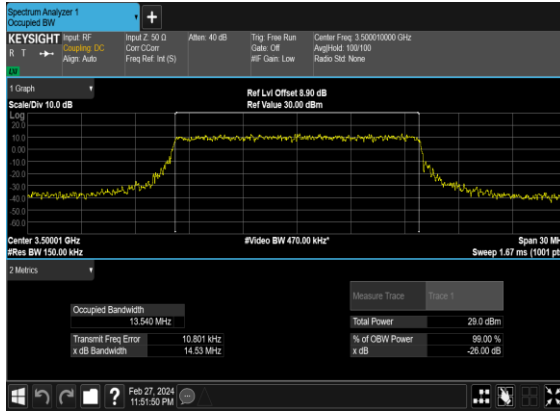

### N77(15M)\_CP-OFDM\_256 QAM\_Outer\_Full\_Mid\_CH

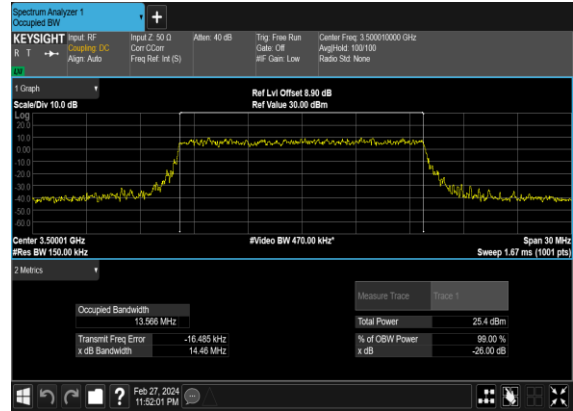

### N77(20M)\_CP- OFDM\_QPSK\_Outer\_Full\_Mid\_CH

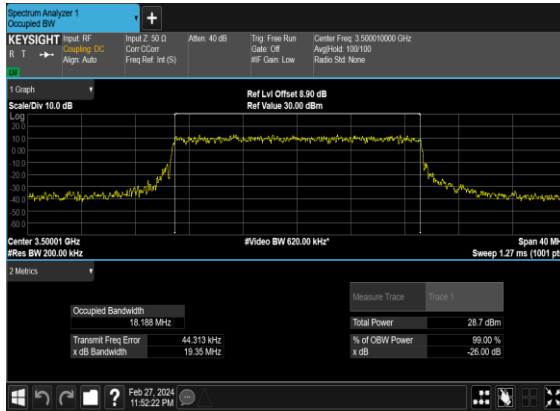

### N77(20M)\_CP-OFDM\_16 QAM\_Outer\_Full\_Mid\_CH

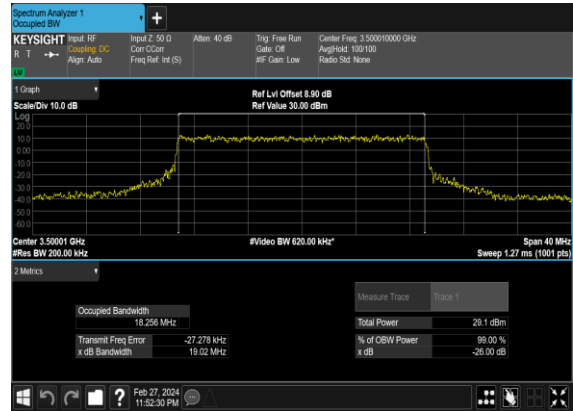

### N77(20M)\_CP-OFDM\_64 QAM\_Outer\_Full\_Mid\_CH

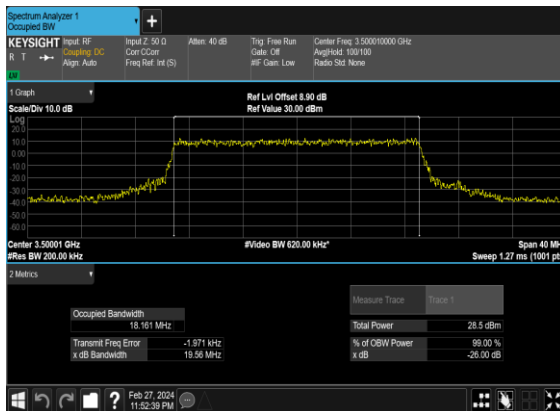

### N77(20M)\_CP-OFDM\_256 QAM\_Outer\_Full\_Mid\_CH

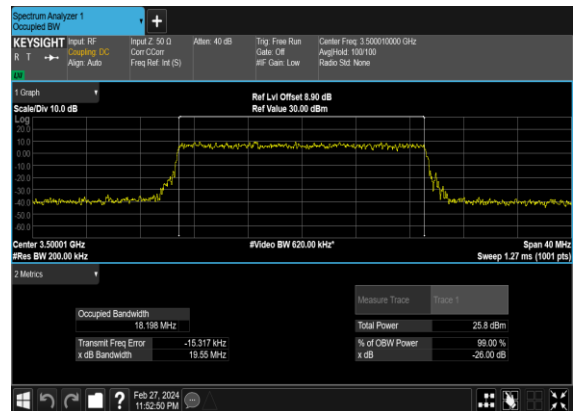

### N77(25M)\_CP-OFDM\_QPSK\_Outer\_Full\_Mid\_CH

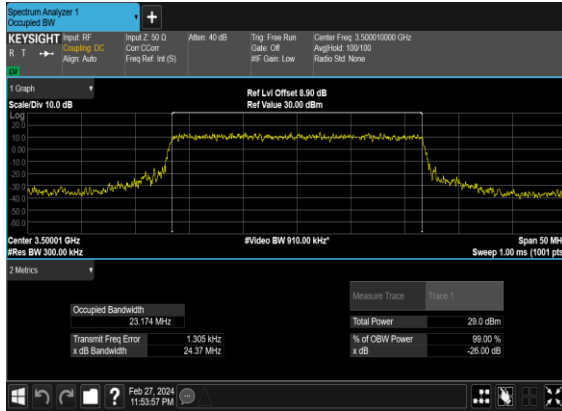

### N77(25M)\_CP-OFDM\_16 QAM\_Outer\_Full\_Mid\_CH

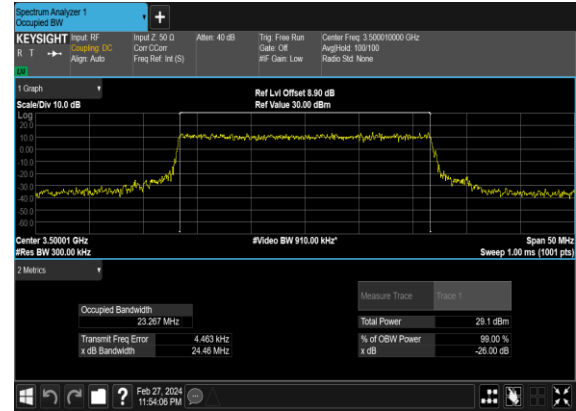

### N77(25M)\_CP-OFDM\_64 QAM\_Outer\_Full\_Mid\_CH



### N77(25M)\_CP-OFDM\_256 QAM\_Outer\_Full\_Mid\_CH

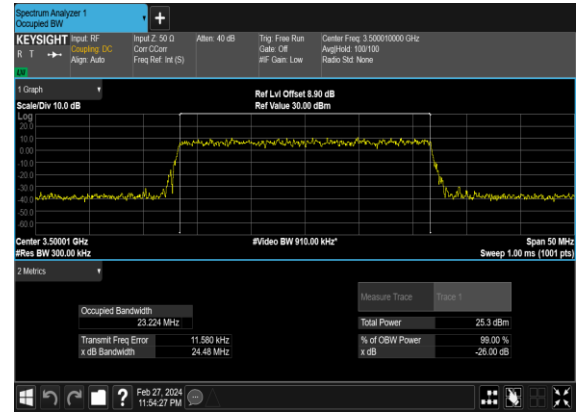

### N77(30M)\_CP-OFDM\_QPSK\_Outer\_Full\_Mid\_CH

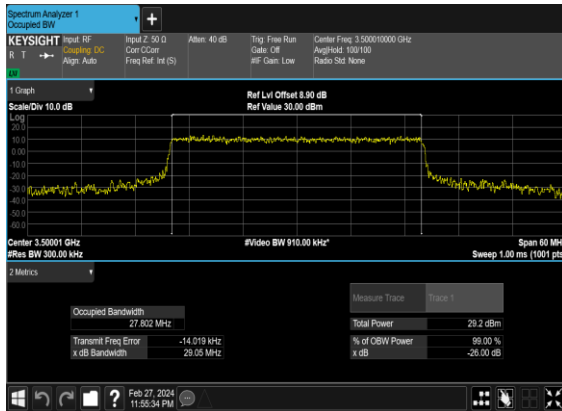

### N77(30M)\_CP-OFDM\_16 QAM\_Outer\_Full\_Mid\_CH

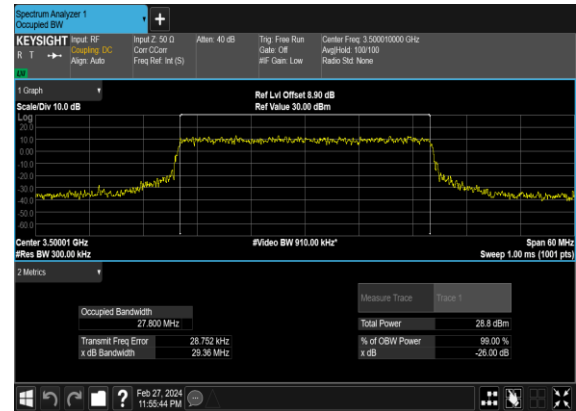

### N77(30M)\_CP-OFDM\_64 QAM\_Outer\_Full\_Mid\_CH

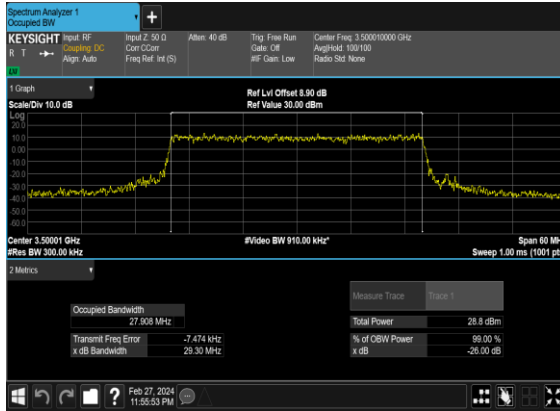

### N77(30M)\_CP-OFDM\_256 QAM\_Outer\_Full\_Mid\_CH

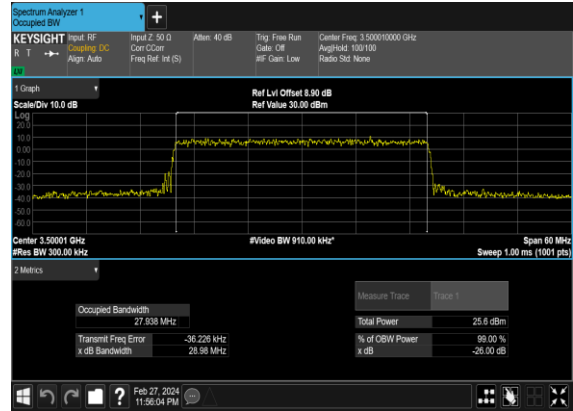

### N77(40M)\_CP- OFDM\_QPSK\_Outer\_Full\_Mid\_CH

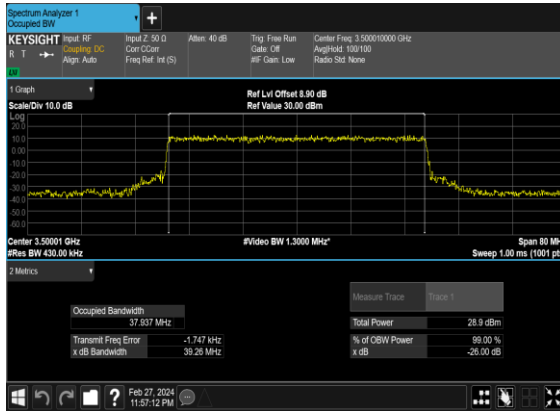

### N77(40M)\_CP-OFDM\_16 QAM\_Outer\_Full\_Mid\_CH

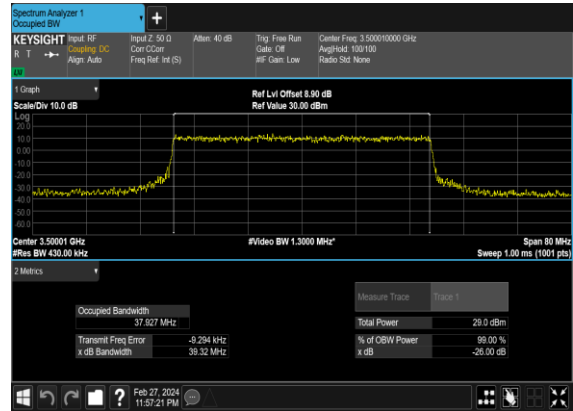

### N77(40M)\_CP-OFDM\_64 QAM\_Outer\_Full\_Mid\_CH

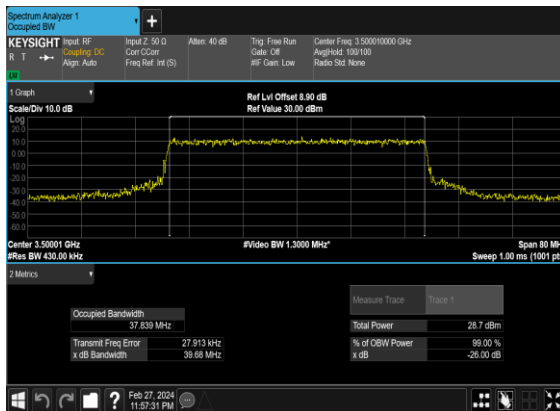

### N77(40M)\_CP-OFDM\_256 QAM\_Outer\_Full\_Mid\_CH

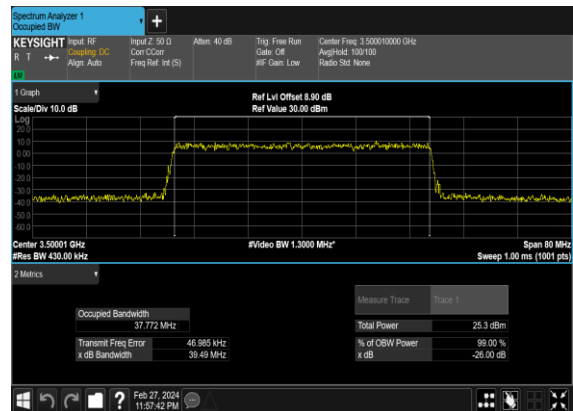

### N77(50M)\_CP-OFDM\_QPSK\_Outer\_Full\_Mid\_CH

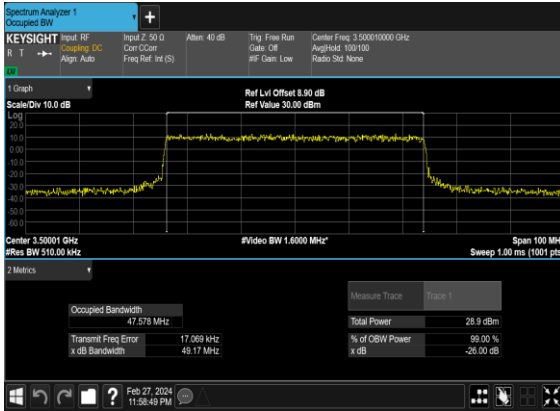

### N77(50M)\_CP-OFDM\_16 QAM\_Outer\_Full\_Mid\_CH

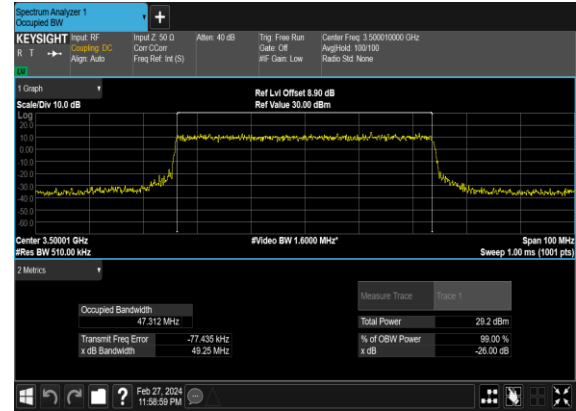

### N77(50M)\_CP-OFDM\_64 QAM\_Outer\_Full\_Mid\_CH



### N77(50M)\_CP-OFDM\_256 QAM\_Outer\_Full\_Mid\_CH

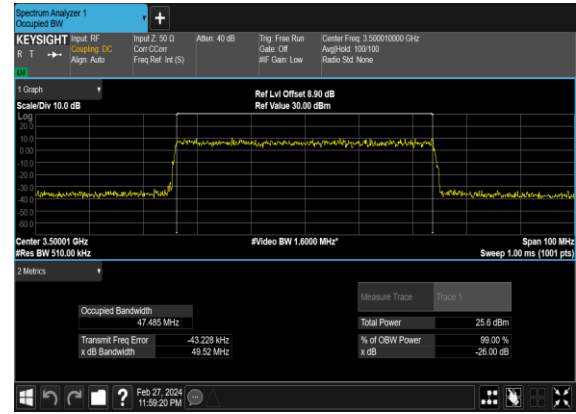

### N77(60M)\_CP-OFDM\_QPSK\_Outer\_Full\_Mid\_CH

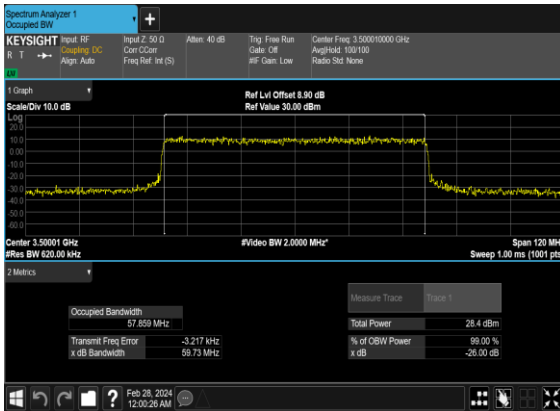

### N77(60M)\_CP-OFDM\_16 QAM\_Outer\_Full\_Mid\_CH

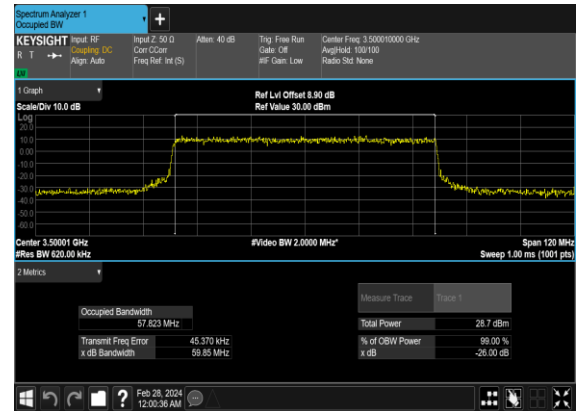

### N77(60M)\_CP-OFDM\_64 QAM\_Outer\_Full\_Mid\_CH

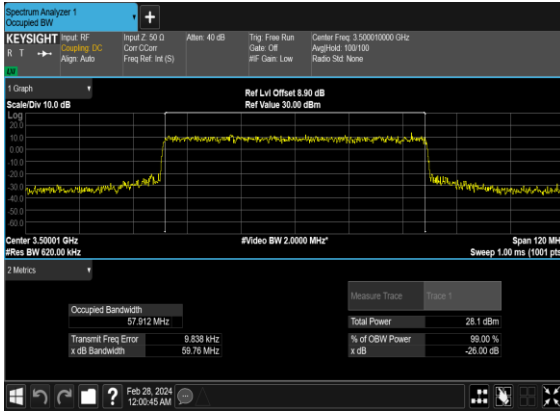

### N77(60M)\_CP-OFDM\_256 QAM\_Outer\_Full\_Mid\_CH

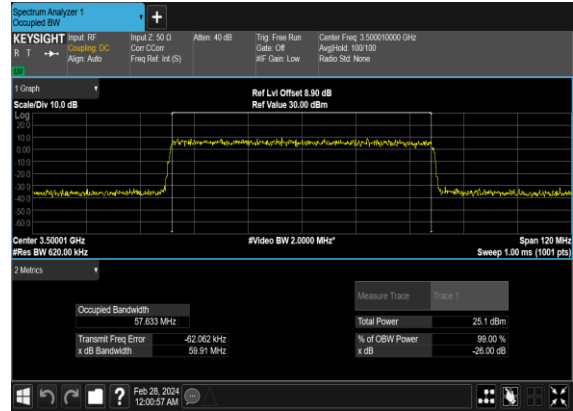

### N77(70M)\_CP- OFDM\_QPSK\_Outer\_Full\_Mid\_CH

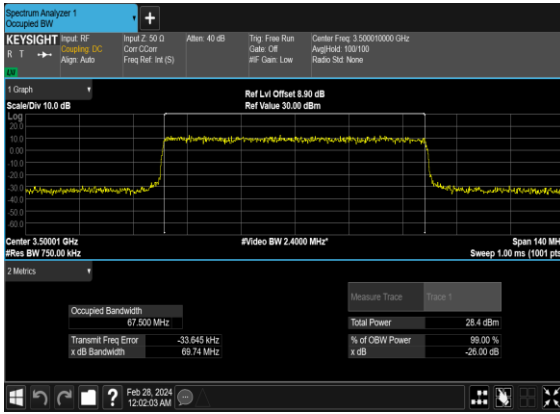

### N77(70M)\_CP-OFDM\_16 QAM\_Outer\_Full\_Mid\_CH

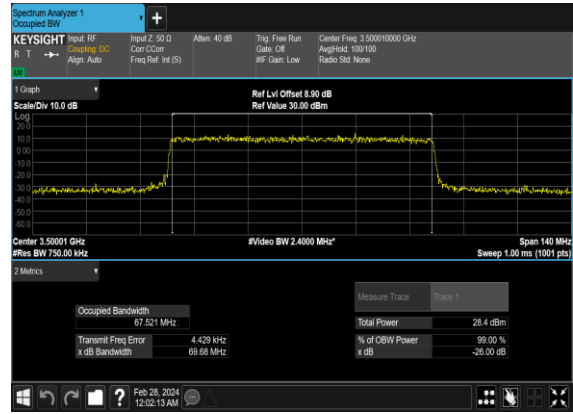

### N77(70M)\_CP-OFDM\_64 QAM\_Outer\_Full\_Mid\_CH

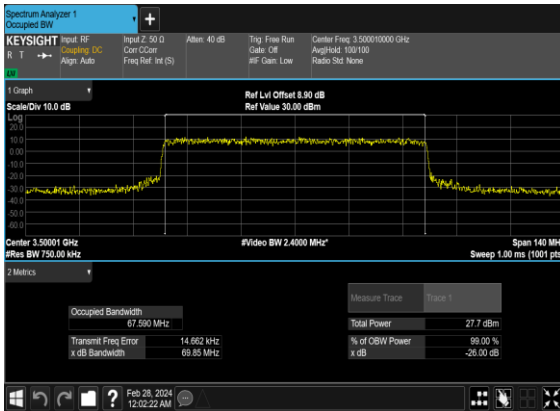

### N77(70M)\_CP-OFDM\_256 QAM\_Outer\_Full\_Mid\_CH

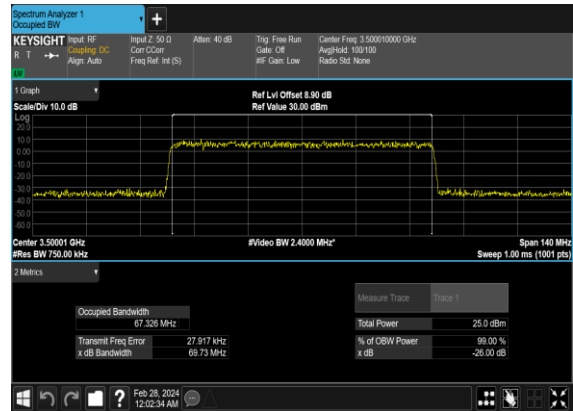

### N77(80M)\_CP-OFDM\_QPSK\_Outer\_Full\_Mid\_CH

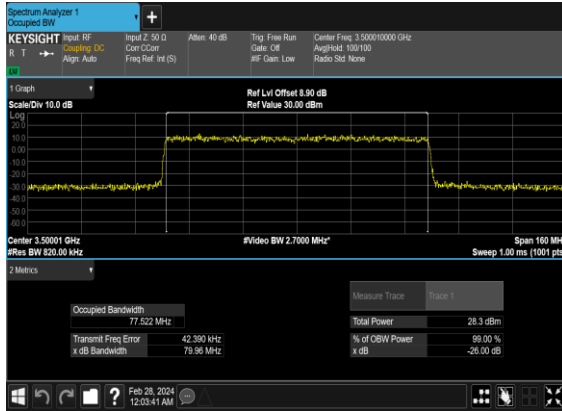

### N77(80M)\_CP-OFDM\_16QAM\_Outer\_Full\_Mid\_CH

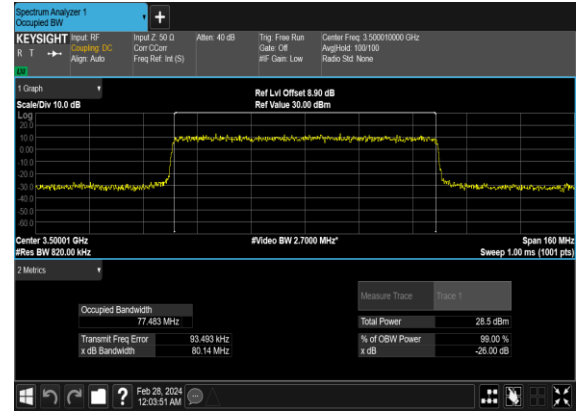

### N77(80M)\_CP-OFDM\_64QAM\_Outer\_Full\_Mid\_CH

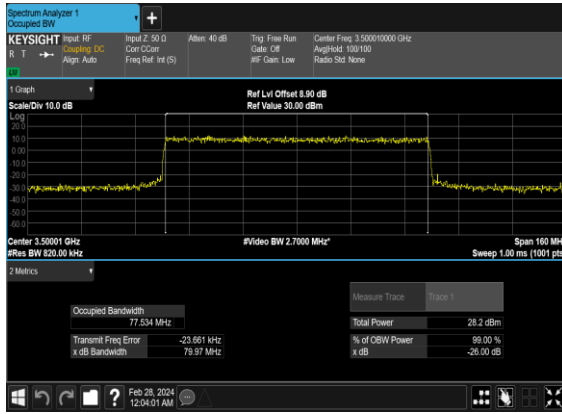

### N77(80M)\_CP-OFDM\_256QAM\_Outer\_Full\_Mid\_CH

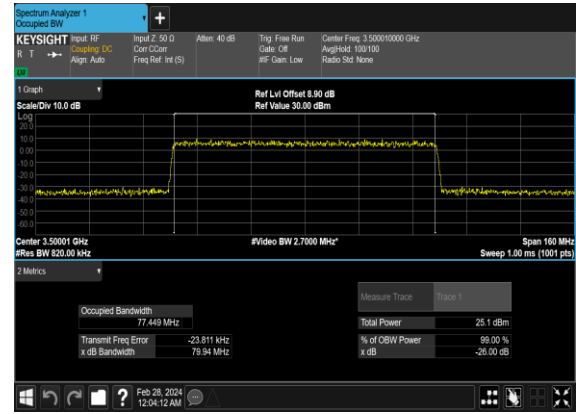

### N77(90M)\_CP-OFDM\_QPSK\_Outer\_Full\_Mid\_CH

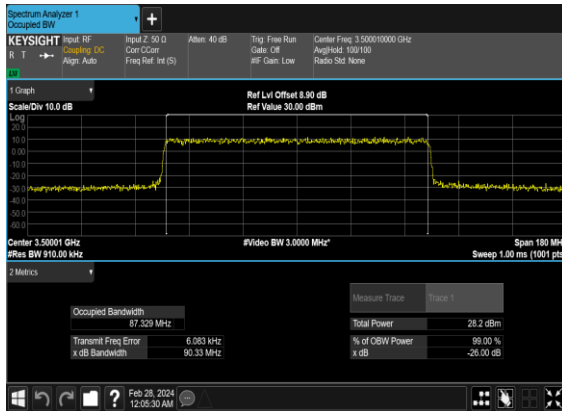

### N77(90M)\_CP-OFDM\_16QAM\_Outer\_Full\_Mid\_CH

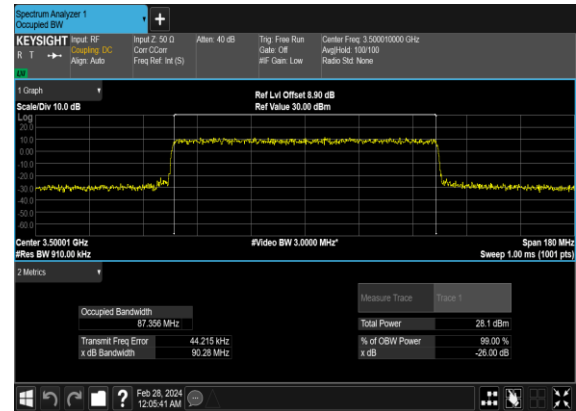

### N77(90M)\_CP-OFDM\_64 QAM\_Outer\_Full\_Mid\_CH

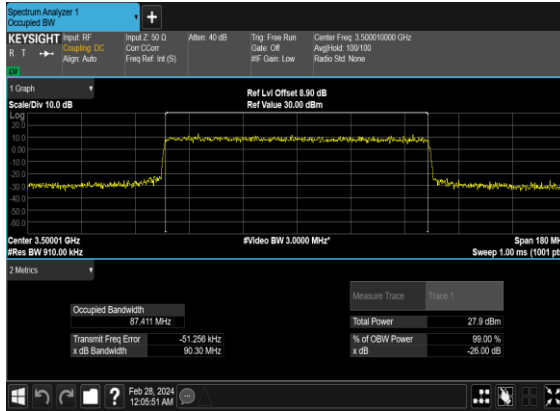

### N77(90M)\_CP-OFDM\_256 QAM\_Outer\_Full\_Mid\_CH

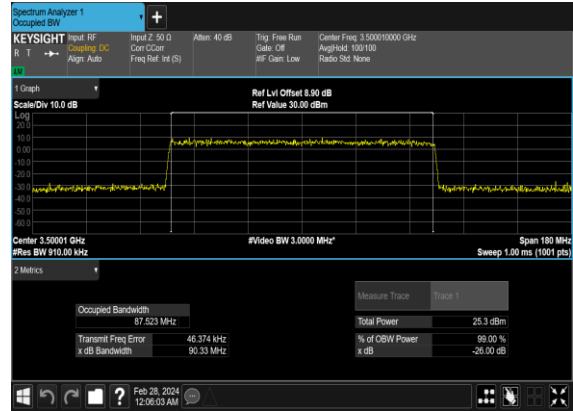

### N77(100M)\_CP- OFDM\_QPSK\_Outer\_Full\_Mid\_CH

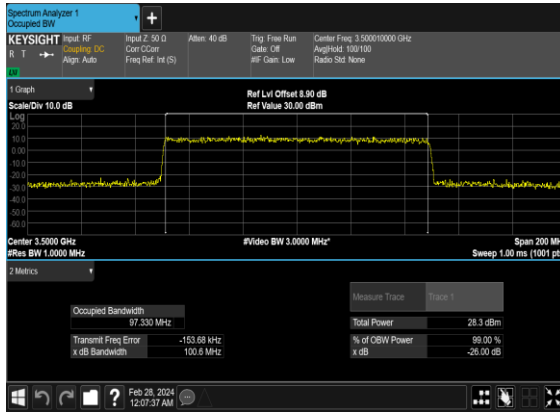

### N77(100M)\_CP-OFDM\_16 QAM\_Outer\_Full\_Mid\_CH

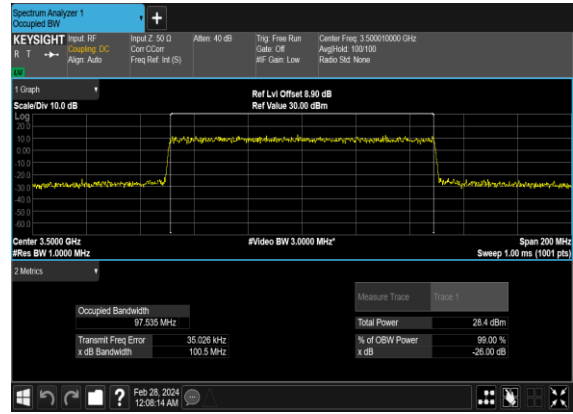

### N77(100M)\_CP-OFDM\_64 QAM\_Outer\_Full\_Mid\_CH

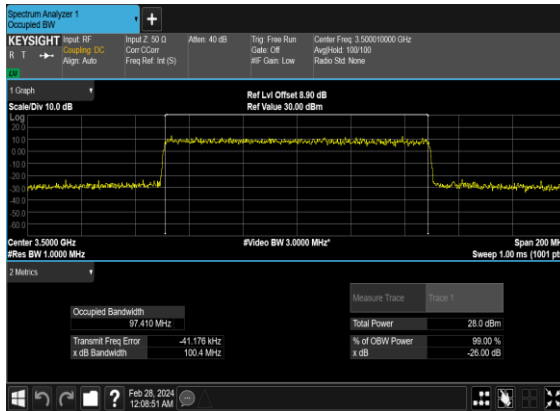

### N77(100M)\_CP-OFDM\_256 QAM\_Outer\_Full\_Mid\_CH

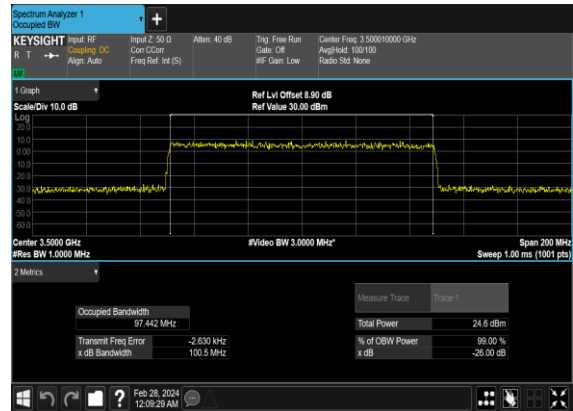



## Conducted Spurious Emissions

NR Band	SCS (kHz)	Bandwidth (MHz)	Arfcn	Freq (MHz)	Modulation	RB	Result	Verdict
77	30	10	630334	3455.01	DFT-s-OFDM BPSK	1@0	see graph	---
77	30	10	630334	3455.01	DFT-s-OFDM BPSK	1@0	see graph	PASS
77	30	10	630334	3455.01	DFT-s-OFDM BPSK	1@0	see graph	PASS
77	30	10	630334	3455.01	DFT-s-OFDM QPSK	1@0	see graph	---
77	30	10	630334	3455.01	DFT-s-OFDM QPSK	1@0	see graph	PASS
77	30	10	630334	3455.01	DFT-s-OFDM QPSK	1@0	see graph	PASS
77	30	10	633334	3500.01	DFT-s-OFDM BPSK	1@0	see graph	---
77	30	10	633334	3500.01	DFT-s-OFDM BPSK	1@0	see graph	PASS
77	30	10	633334	3500.01	DFT-s-OFDM BPSK	1@0	see graph	PASS
77	30	10	633334	3500.01	DFT-s-OFDM QPSK	1@0	see graph	---
77	30	10	633334	3500.01	DFT-s-OFDM QPSK	1@0	see graph	PASS
77	30	10	633334	3500.01	DFT-s-OFDM QPSK	1@0	see graph	PASS
77	30	10	636332	3544.98	DFT-s-OFDM BPSK	1@0	see graph	---
77	30	10	636332	3544.98	DFT-s-OFDM BPSK	1@0	see graph	PASS
77	30	10	636332	3544.98	DFT-s-OFDM BPSK	1@0	see graph	PASS
77	30	10	636332	3544.98	DFT-s-OFDM QPSK	1@0	see graph	---
77	30	10	636332	3544.98	DFT-s-OFDM QPSK	1@0	see graph	PASS
77	30	10	636332	3544.98	DFT-s-OFDM QPSK	1@0	see graph	PASS
77	30	50	631668	3475.02	DFT-s-OFDM BPSK	1@0	see graph	---
77	30	50	631668	3475.02	DFT-s-OFDM BPSK	1@0	see graph	PASS
77	30	50	631668	3475.02	DFT-s-OFDM BPSK	1@0	see graph	PASS
77	30	50	631668	3475.02	DFT-s-OFDM QPSK	1@0	see graph	---

77	30	50	631668	3475.02	DFT-s-OFDM QPSK	1@0	see graph	PASS
77	30	50	631668	3475.02	DFT-s-OFDM QPSK	1@0	see graph	PASS
77	30	50	633334	3500.01	DFT-s-OFDM BPSK	1@0	see graph	---
77	30	50	633334	3500.01	DFT-s-OFDM BPSK	1@0	see graph	PASS
77	30	50	633334	3500.01	DFT-s-OFDM BPSK	1@0	see graph	PASS
77	30	50	633334	3500.01	DFT-s-OFDM QPSK	1@0	see graph	---
77	30	50	633334	3500.01	DFT-s-OFDM QPSK	1@0	see graph	PASS
77	30	50	633334	3500.01	DFT-s-OFDM QPSK	1@0	see graph	PASS
77	30	50	635000	3525.0	DFT-s-OFDM BPSK	1@0	see graph	---
77	30	50	635000	3525.0	DFT-s-OFDM BPSK	1@0	see graph	PASS
77	30	50	635000	3525.0	DFT-s-OFDM BPSK	1@0	see graph	PASS
77	30	50	635000	3525.0	DFT-s-OFDM QPSK	1@0	see graph	---
77	30	50	635000	3525.0	DFT-s-OFDM QPSK	1@0	see graph	PASS
77	30	50	635000	3525.0	DFT-s-OFDM QPSK	1@0	see graph	PASS
77	30	100	633334	3500.01	DFT-s-OFDM BPSK	1@0	see graph	---
77	30	100	633334	3500.01	DFT-s-OFDM BPSK	1@0	see graph	PASS
77	30	100	633334	3500.01	DFT-s-OFDM BPSK	1@0	see graph	PASS
77	30	100	633334	3500.01	DFT-s-OFDM QPSK	1@0	see graph	---
77	30	100	633334	3500.01	DFT-s-OFDM QPSK	1@0	see graph	PASS
77	30	100	633334	3500.01	DFT-s-OFDM QPSK	1@0	see graph	PASS

### N77(10M)\_DFT-s-OFDM\_BPSK\_Edge\_1RB\_Left\_Low\_CH

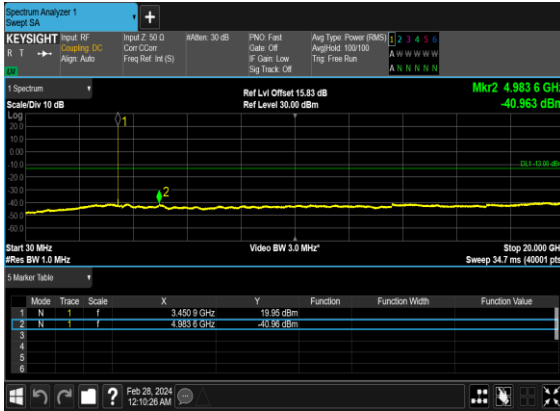

### N77(10M)\_DFT-s-OFDM\_BPSK\_Edge\_1RB\_Left\_Low\_CH

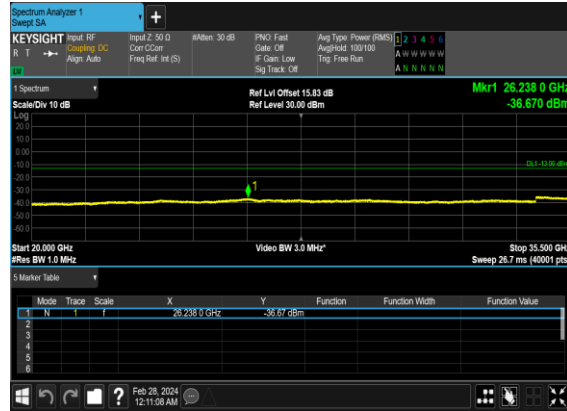

### N77(10M)\_DFT-s-OFDM\_QPSK\_Edge\_1RB\_Left\_Low\_CH



### N77(10M)\_DFT-s-OFDM\_QPSK\_Edge\_1RB\_Left\_Low\_CH

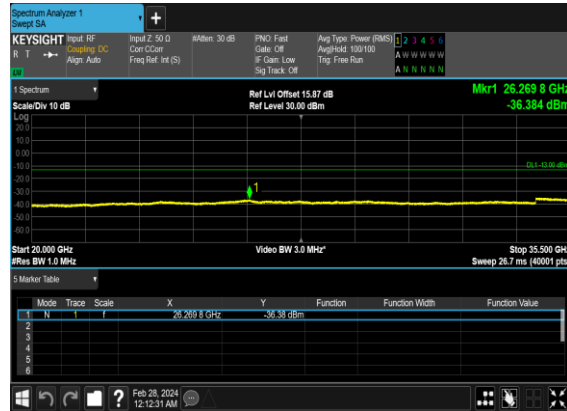

### N77(10M)\_DFT-s-OFDM\_BPSK\_Edge\_1RB\_Left\_Mid\_CH

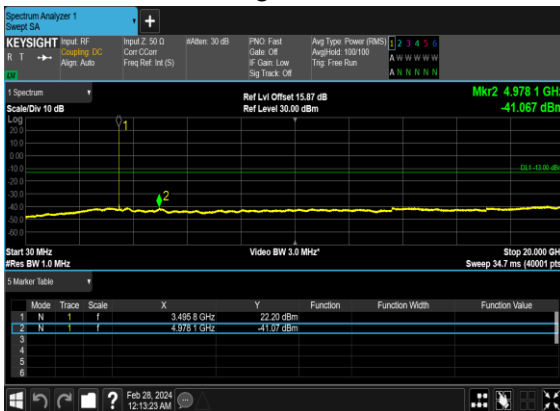

### N77(10M)\_DFT-s-OFDM\_BPSK\_Edge\_1RB\_Left\_Mid\_CH

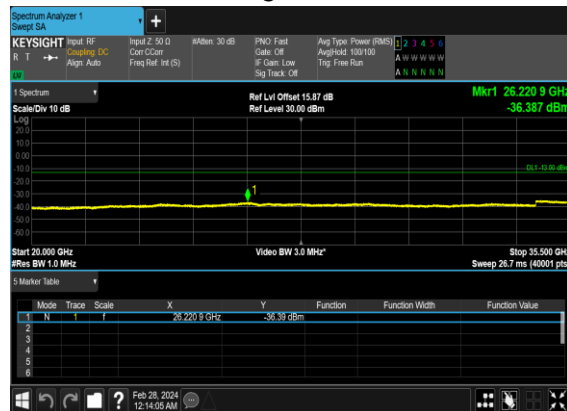

### N77(10M)\_DFT-s-OFDM\_QPSK\_Edge\_1RB\_Left\_Mid\_CH

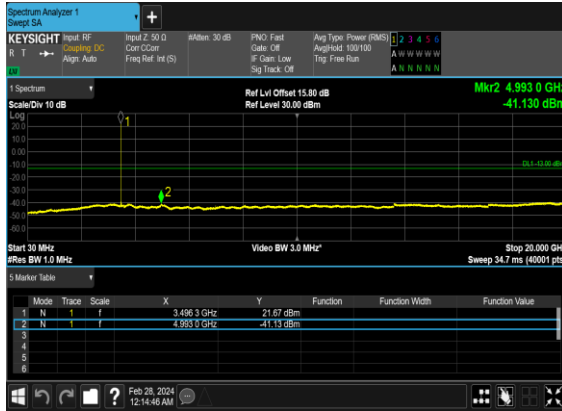

### N77(10M)\_DFT-s-OFDM\_QPSK\_Edge\_1RB\_Left\_Mid\_CH

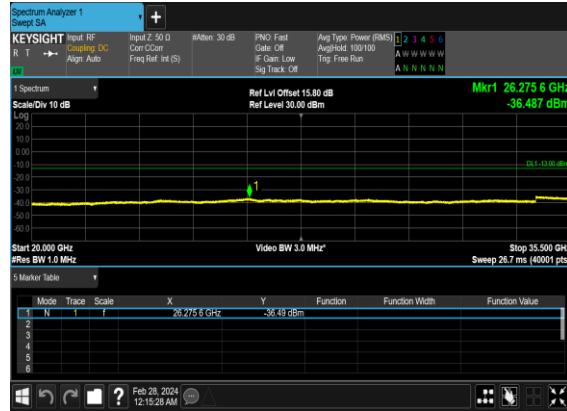

### N77(10M)\_DFT-s-OFDM\_BPSK\_Edge\_1RB\_Left\_High\_CH

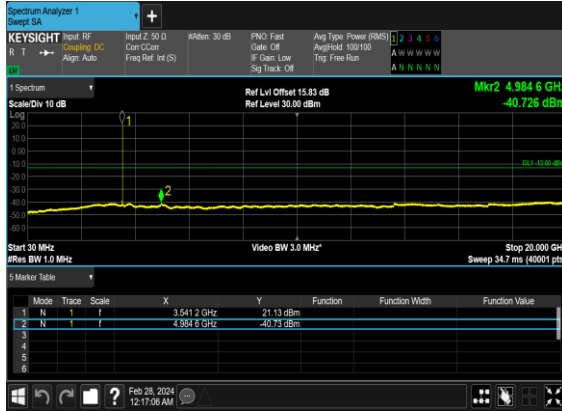

### N77(10M)\_DFT-s-OFDM\_BPSK\_Edge\_1RB\_Left\_High\_CH

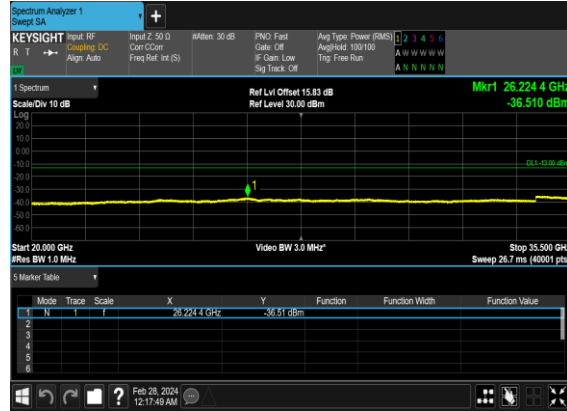

### N77(10M)\_DFT-s-OFDM\_QPSK\_Edge\_1RB\_Left\_High\_CH



### N77(10M)\_DFT-s-OFDM\_QPSK\_Edge\_1RB\_Left\_High\_CH

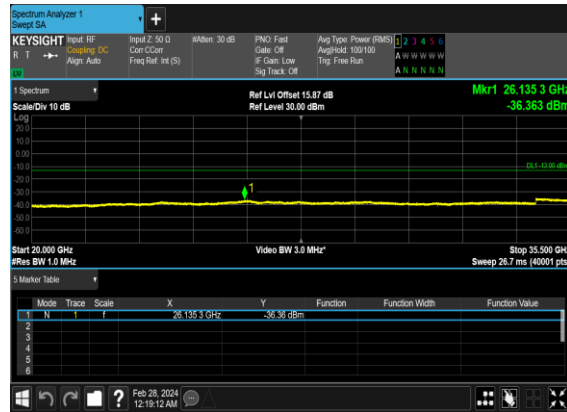

N77(50M)\_DFT-s-OFDM\_BPSK\_Edge\_1RB\_Left\_Low\_CH

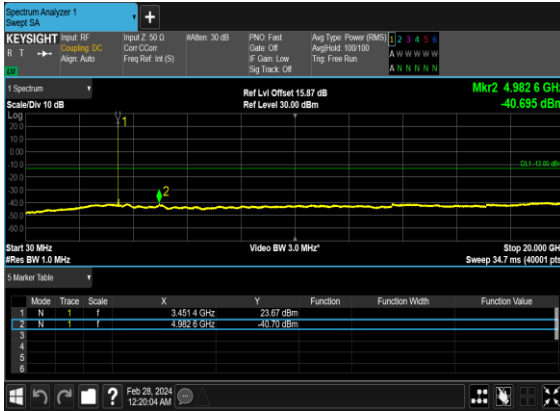

N77(50M)\_DFT-s-OFDM\_BPSK\_Edge\_1RB\_Left\_Low\_CH

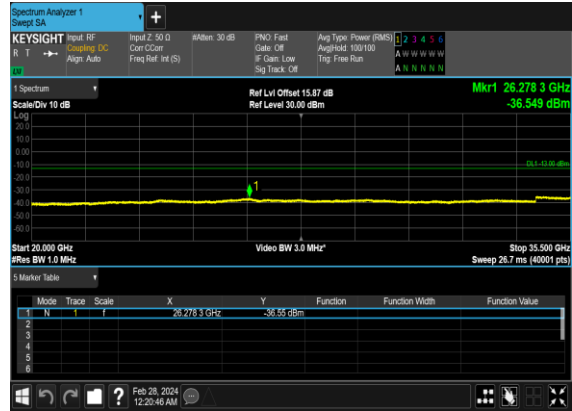

N77(50M)\_DFT-s-OFDM\_QPSK\_Edge\_1RB\_Left\_Low\_CH

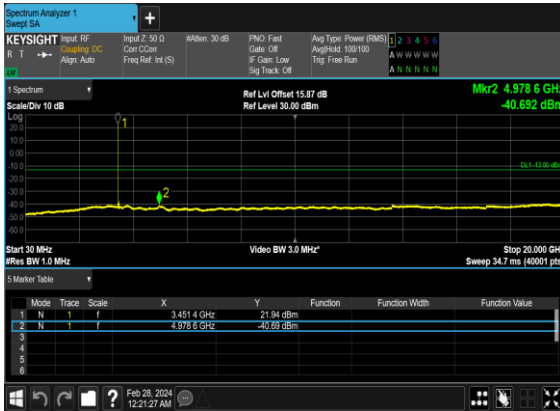

N77(50M)\_DFT-s-OFDM\_QPSK\_Edge\_1RB\_Left\_Low\_CH

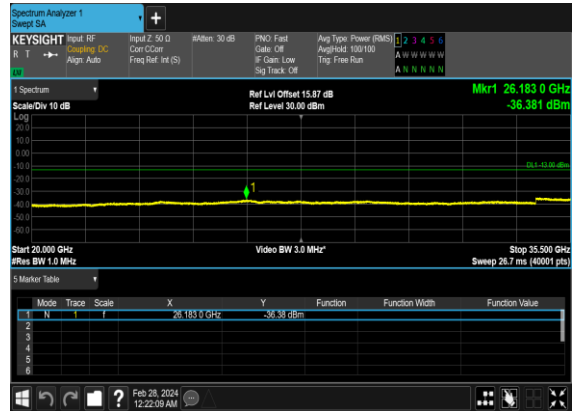

N77(50M)\_DFT-s-OFDM\_BPSK\_Edge\_1RB\_Left\_Mid\_CH

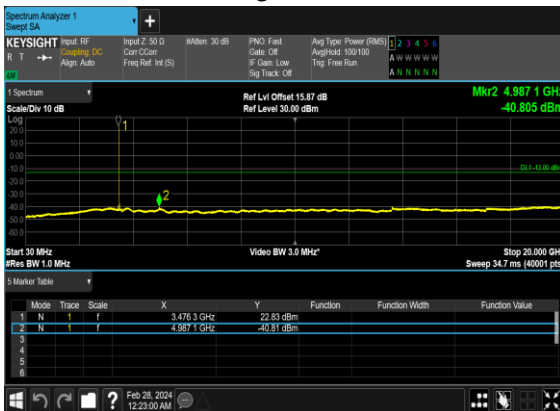

N77(50M)\_DFT-s-OFDM\_BPSK\_Edge\_1RB\_Left\_Mid\_CH

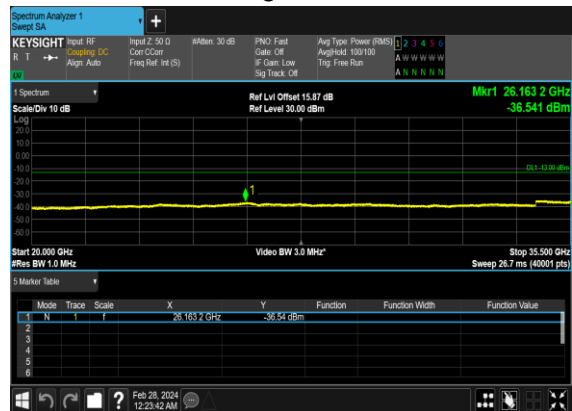

### N77(50M)\_DFT-s-OFDM\_QPSK\_Edge\_1RB\_Left\_Mid\_CH

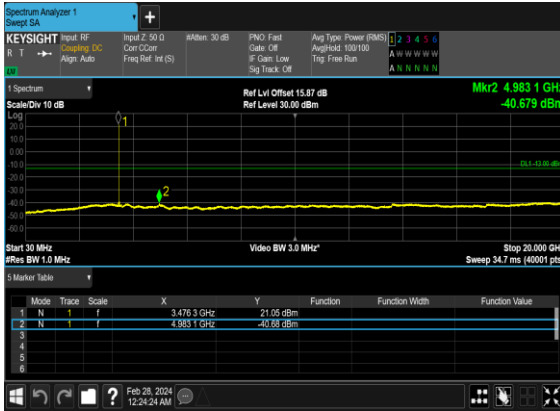

### N77(50M)\_DFT-s-OFDM\_QPSK\_Edge\_1RB\_Left\_Mid\_CH

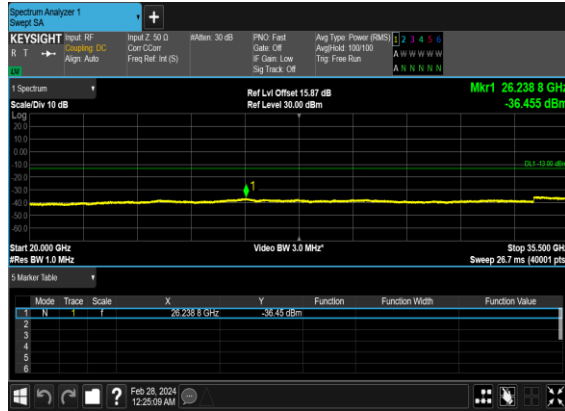

### N77(50M)\_DFT-s-OFDM\_BPSK\_Edge\_1RB\_Left\_High\_CH



### N77(50M)\_DFT-s-OFDM\_BPSK\_Edge\_1RB\_Left\_High\_CH

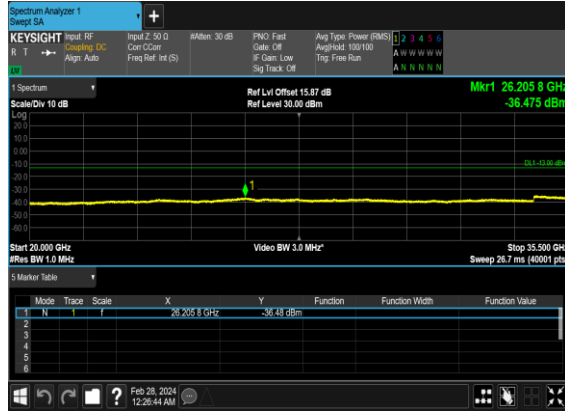

### N77(50M)\_DFT-s-OFDM\_QPSK\_Edge\_1RB\_Left\_High\_CH



### N77(50M)\_DFT-s-OFDM\_QPSK\_Edge\_1RB\_Left\_High\_CH

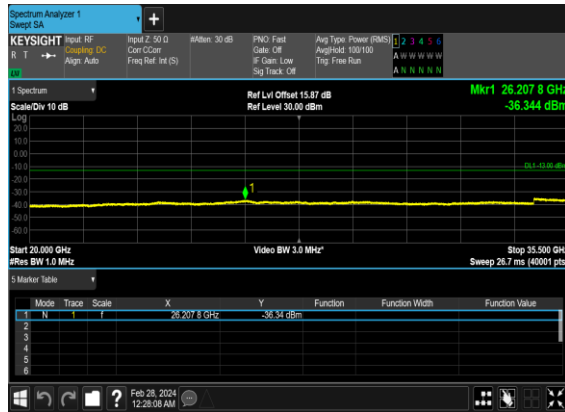

### N77(100M)\_DFT-s-OFDM\_BPSK\_Edge\_1RB\_Left\_Mid\_CH

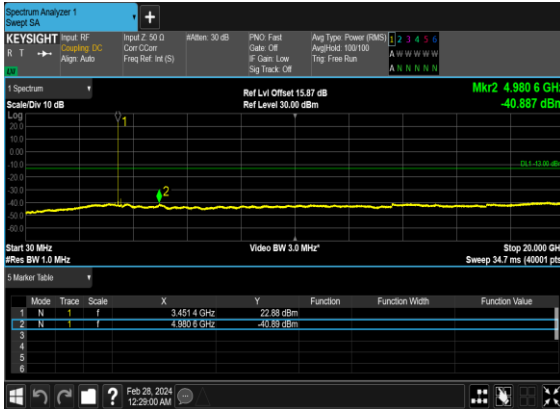

### N77(100M)\_DFT-s-OFDM\_BPSK\_Edge\_1RB\_Left\_Mid\_CH

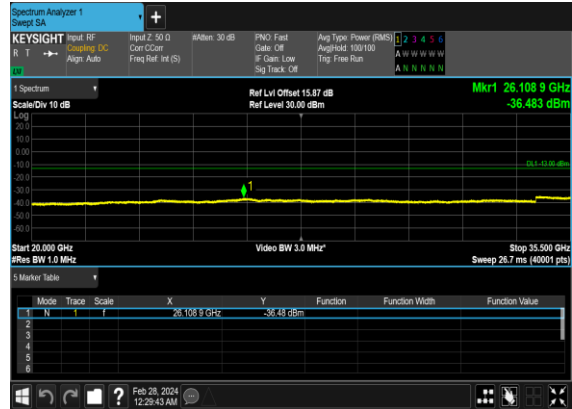

### N77(100M)\_DFT-s-OFDM\_QPSK\_Edge\_1RB\_Left\_Mid\_CH



### N77(100M)\_DFT-s-OFDM\_QPSK\_Edge\_1RB\_Left\_Mid\_CH



## Conducted Band Edge

NR Band	SCS (kHz)	Bandwidth (MHz)	Arfcn	Freq (MHz)	Modulation	RB	Result	Verdict
77	30	10	630334	3455.01	DFT-s-OFDM BPSK	1@0	see graph	PASS
77	30	10	630334	3455.01	DFT-s-OFDM QPSK	1@0	see graph	PASS
77	30	10	630334	3455.01	DFT-s-OFDM BPSK	24@0	see graph	PASS
77	30	10	630334	3455.01	DFT-s-OFDM QPSK	24@0	see graph	PASS
77	30	10	636332	3544.98	DFT-s-OFDM BPSK	1@23	see graph	PASS
77	30	10	636332	3544.98	DFT-s-OFDM QPSK	1@23	see graph	PASS
77	30	10	636332	3544.98	DFT-s-OFDM BPSK	24@0	see graph	PASS
77	30	10	636332	3544.98	DFT-s-OFDM QPSK	24@0	see graph	PASS
77	30	50	631668	3475.02	DFT-s-OFDM BPSK	1@0	see graph	PASS
77	30	50	631668	3475.02	DFT-s-OFDM QPSK	1@0	see graph	PASS
77	30	50	631668	3475.02	DFT-s-OFDM BPSK	128@0	see graph	PASS
77	30	50	631668	3475.02	DFT-s-OFDM QPSK	128@0	see graph	PASS
77	30	50	635000	3525.0	DFT-s-OFDM BPSK	1@132	see graph	PASS
77	30	50	635000	3525.0	DFT-s-OFDM QPSK	1@132	see graph	PASS
77	30	50	635000	3525.0	DFT-s-OFDM BPSK	128@0	see graph	PASS
77	30	50	635000	3525.0	DFT-s-OFDM QPSK	128@0	see graph	PASS
77	30	100	633334	3500.01	DFT-s-OFDM BPSK	1@0	see graph	PASS
77	30	100	633334	3500.01	DFT-s-OFDM QPSK	1@0	see graph	PASS
77	30	100	633334	3500.01	DFT-s-OFDM BPSK	1@272	see graph	PASS
77	30	100	633334	3500.01	DFT-s-OFDM QPSK	1@272	see graph	PASS
77	30	100	633334	3500.01	DFT-s-OFDM BPSK	270@0	see graph	PASS
77	30	100	633334	3500.01	DFT-s-OFDM QPSK	270@0	see graph	PASS



### N77(10M)\_DFT-s- OFDM\_BPSK\_Edge\_1RB\_Left\_Low\_CH

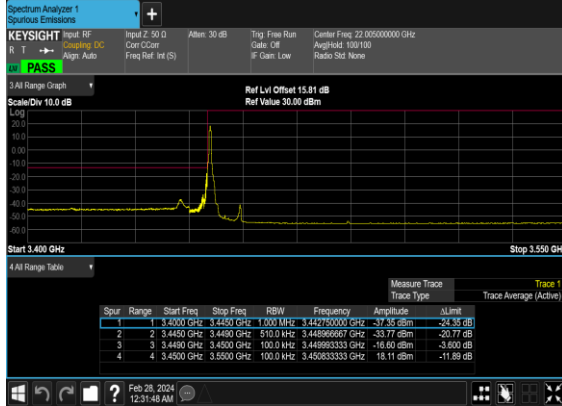

### N77(10M)\_DFT-s- OFDM\_QPSK\_Edge\_1RB\_Left\_Low\_CH



### N77(10M)\_DFT-s- OFDM\_BPSK\_Outer\_Full\_Low\_CH

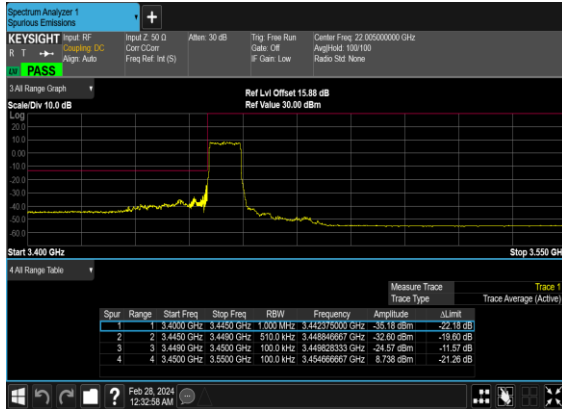

### N77(10M)\_DFT-s- OFDM\_QPSK\_Outer\_Full\_Low\_CH

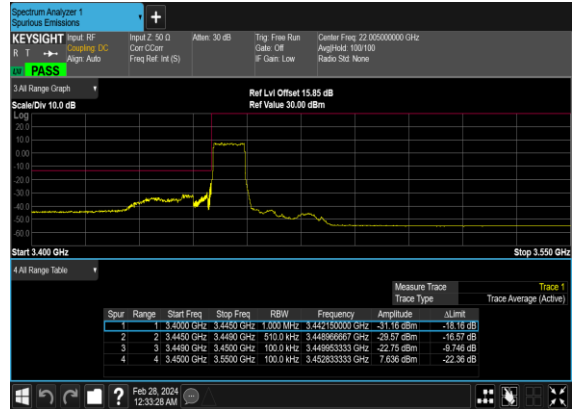

### N77(10M)\_DFT-s- OFDM\_BPSK\_Edge\_1RB\_Right\_High\_CH

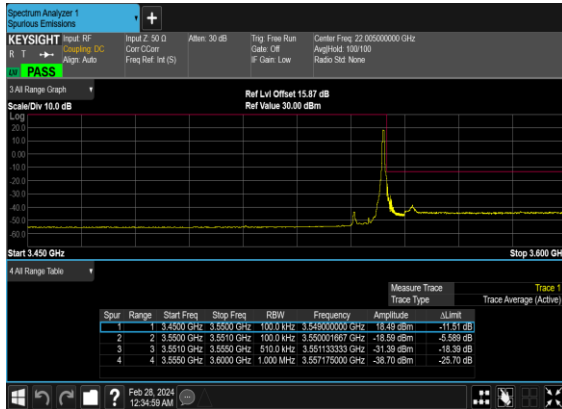

### N77(10M)\_DFT-s- OFDM\_QPSK\_Edge\_1RB\_Right\_High\_CH

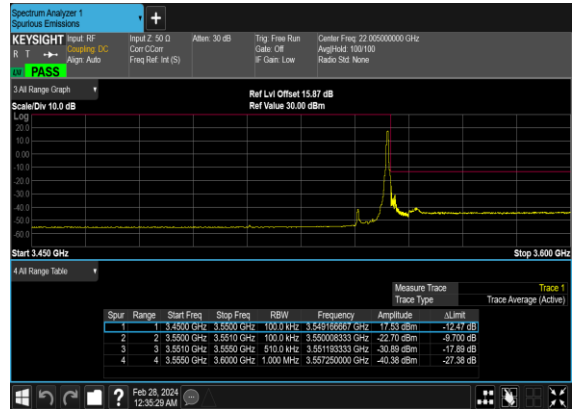

### N77(10M)\_DFT-s-OFDM\_BPSK\_Outer\_Full\_High\_CH

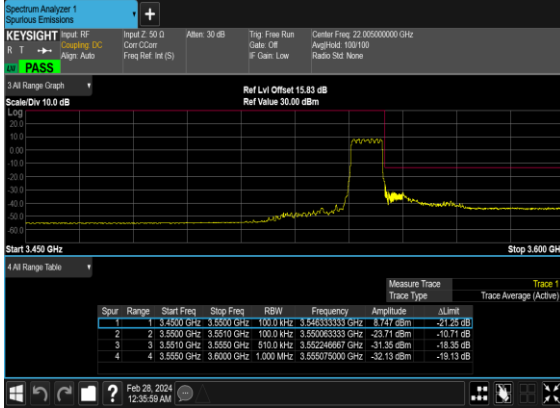

### N77(10M)\_DFT-s-OFDM\_QPSK\_Outer\_Full\_High\_CH

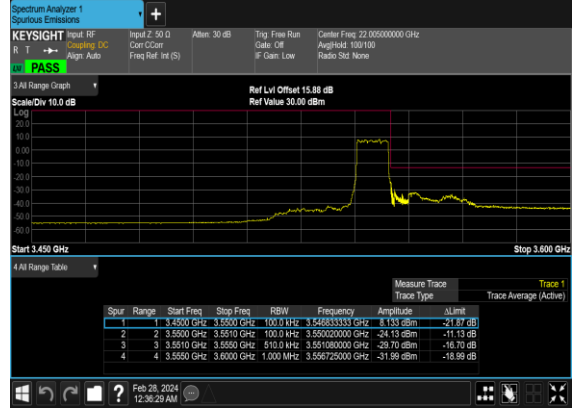

### N77(50M)\_DFT-s-OFDM\_BPSK\_Edge\_1RB\_Left\_Low\_CH



### N77(50M)\_DFT-s-OFDM\_QPSK\_Edge\_1RB\_Left\_Low\_CH

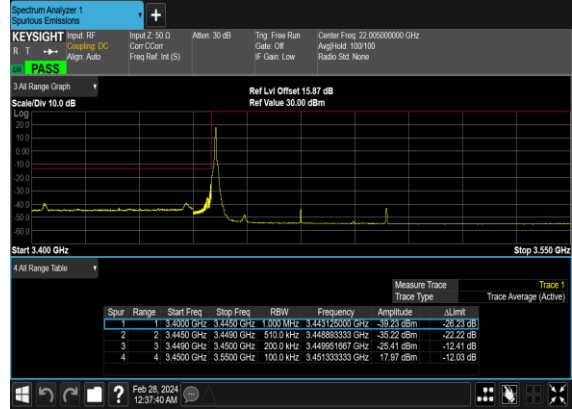

### N77(50M)\_DFT-s-OFDM\_BPSK\_Outer\_Full\_Low\_CH

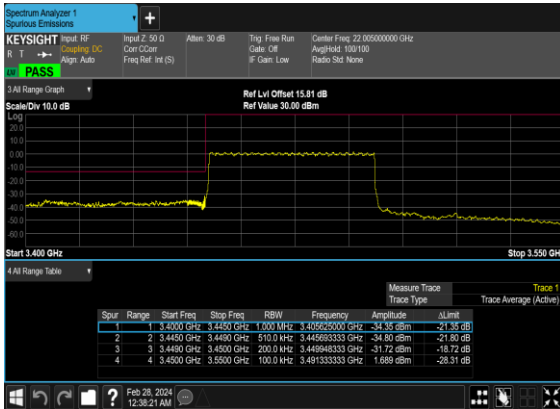

### N77(50M)\_DFT-s-OFDM\_QPSK\_Outer\_Full\_Low\_CH

