

FCC RF Test Report

APPLICANT : Xiaomi Communications Co., Ltd.
EQUIPMENT : Mobile Phone
BRAND NAME : Xiaomi
MODEL NAME : A301XM
FCC ID : 2AFZZND5R
STANDARD : 47 CFR Part 2, Part 27 Subpart Q
CLASSIFICATION : PCS Licensed Transmitter Held to Ear (PCE)
TEST DATE(S) : Jun. 14, 2023 ~ Jul. 19, 2023

We, Sporton International Inc. (KunShan), would like to declare that the tested sample has been evaluated in accordance with the procedures given in ANSI C63.26-2015 and shown compliance with the applicable technical standards.

The test results in this report apply exclusively to the tested model / sample. Without written approval of Sporton International Inc. (KunShan), the test report shall not be reproduced except in full.

Jason Jia



Approved by: Jason Jia

Sporton International Inc. (Kunshan)

**No. 1098, Pengxi North Road, Kunshan Economic Development Zone Jiangsu Province 215300
People's Republic of China**



TABLE OF CONTENTS

REVISION HISTORY..... 3
SUMMARY OF TEST RESULT 4
1 GENERAL DESCRIPTION 5
1.1 Applicant 5
1.2 Manufacturer 5
1.3 Product Feature of Equipment Under Test 5
1.4 Product Specification of Equipment Under Test 5
1.5 Modification of EUT 6
1.6 Maximum EIRP Power and Emission Designator 6
1.7 Testing Site 7
1.8 Test Software 7
1.9 Applied Standards 7
2 TEST CONFIGURATION OF EQUIPMENT UNDER TEST 8
2.1 Test Mode 8
2.2 Connection Diagram of Test System 9
2.3 Support Unit used in test configuration and system 9
2.4 Measurement Results Explanation Example 9
2.5 Frequency List of Low/Middle/High Channels 10
3 CONDUCTED TEST ITEMS 11
3.1 Measuring Instruments 11
3.2 Test Setup 11
3.3 Test Result of Conducted Test 11
3.4 Conducted Output Power Measurement 12
3.5 Peak-to-Average Ratio 13
3.6 EIRP 14
3.7 Occupied Bandwidth 15
3.8 Conducted Band Edge Measurement 16
3.9 Conducted Spurious Emission Measurement 17
3.10 Frequency Stability Measurement 18
4 RADIATED TEST ITEMS 19
4.1 Measuring Instruments 19
4.2 Test Setup 19
4.3 Test Result of Radiated Test 20
4.4 Radiated Spurious Emission Measurement 21
5 LIST OF MEASURING EQUIPMENT 22
6 MEASUREMENT UNCERTAINTY 23
APPENDIX A. TEST RESULTS OF CONDUCTED TEST
APPENDIX B. TEST RESULTS OF RADIATED TEST
APPENDIX C. TEST SETUP PHOTOGRAPHS



SUMMARY OF TEST RESULT

Report Section	FCC Rule	Description	Limit	Result	Remark
3.4	§2.1046	Conducted Output Power	—	Report Only	-
3.5	§27.50 (k)(4)	Peak-to-Average Ratio	<13dB	PASS	
3.6	§27.50 (k)(3)	EIRP	EIRP < 1W (30dBm)	PASS	-
3.7	§2.1049	Occupied Bandwidth	—	Report Only	-
3.8	§2.1051 §27.53 (n)(2)	Conducted Band Edge Measurement	-13dBm/MHz	PASS	-
3.9	§2.1051 §27.53 (n)(2)	Conducted Spurious Emission	-13dBm/MHz	PASS	-
3.10	§2.1055 §27.54	Frequency Stability Temperature & Voltage	Within the band	PASS	-
4.4	§2.1053 §27.53 (n)(2)	Radiated Spurious Emission	-13dBm/MHz	PASS	Under limit 45.49 dB at 10368.000 MHz

Note: only 20M BW and Power/EIRP/RSE are assessed in this report, all the other test results are leveraged from original report FG351205K which is issued separately.

Conformity Assessment Condition:
1. The test results (PASS/FAIL) with all measurement uncertainty excluded are presented against the regulation limits or in accordance with the requirements stipulated by the applicant/manufacturer who shall bear all the risks of non-compliance that may potentially occur if measurement uncertainty is taken into account.
2. The measurement uncertainty please refer to each test result in the section "Measurement Uncertainty"
Disclaimer:
The product specifications of the EUT presented in the test report that may affect the test assessments are declared by the manufacturer who shall take full responsibility for the authenticity.

1 General Description

1.1 Applicant

Xiaomi Communications Co., Ltd.

#019, 9th Floor, Building 6, 33 Xi'erqi Middle Road, Haidian District, Beijing, China, 100085

1.2 Manufacturer

Xiaomi Communications Co., Ltd.

#019, 9th Floor, Building 6, 33 Xi'erqi Middle Road, Haidian District, Beijing, China, 100085

1.3 Product Feature of Equipment Under Test

Product Feature	
Equipment	Mobile Phone
Brand Name	Xiaomi
Model Name	A301XM
FCC ID	2AFZZND5R
IMEI Code	Conducted: 869272060003543/86927060003550 Radiation : 869272060005449 / 869272060005456
HW Version	P2.0
SW Version	MIUI 14
EUT Stage	Identical Prototype

1.4 Product Specification of Equipment Under Test

Product Feature	
Tx/Rx Frequency	5G NR n77: 3450 MHz ~ 3550 MHz 5G NR n78: 3450 MHz ~ 3550 MHz
SCS	30kHz
Bandwidth	n77/n78(30kHz): 20 / 30 / 40 / 50 / 60 / 80 / 90 / 100MHz
Antenna Gain	<p><Ant. 1> 5G NR n77: -7.00 dBi 5G NR n78: -7.00 dBi</p> <p><Ant. 5> 5G NR n77: -0.26 dBi 5G NR n78: -0.67 dBi</p> <p><Ant. 6> 5G NR n77: -1.00 dBi 5G NR n78: -1.00 dBi</p> <p><Ant. 7> 5G NR n77: -6.10 dBi 5G NR n78: -6.10 dBi</p>
Type of Modulation	CP-OFDM: QPSK / 16QAM / 64QAM / 256QAM DFT-s-OFDM: PI/2 BPSK / QPSK / 16QAM / 64QAM / 256QAM

Remark:

1. The maximum EIRP is calculated from max output power and max antenna gain, only the maximum

EIRP of Ant.5 for 5G NR n77/n78 are shown in the report.

2. 5G NR n77/n78 supports SA mode only.

1.5 Modification of EUT

No modifications are made to the EUT during all test items.

1.6 Maximum EIRP Power and Emission Designator

5G NR n77		PI/2 BPSK / QPSK		16QAM/64QAM/256QAM	
BW (MHz)	Frequency Range (MHz)	Maximum EIRP(W)	Emission Designator (99%OBW)	Maximum EIRP(W)	Emission Designator (99%OBW)
20	3460.02 ~ 3540.00	0.2793	18M2G7D	0.2099	18M2W7D
30	3465.00 ~ 3534.99	0.2716	-	0.2037	-
40	3470.01 ~ 3529.98	0.2704	-	0.2075	-
50	3475.02 ~ 3525.00	0.2761	-	0.2056	-
60	3480.00 ~ 3519.99	0.2742	-	0.2099	-
80	3490.02 ~ 3510.00	0.2698	-	0.1995	-
90	3495.00 ~ 3504.99	0.2673	-	0.1959	-
100	3500.01	0.2805	-	0.2183	-

5G NR n78		PI/2 BPSK / QPSK		16QAM/64QAM/256QAM	
BW (MHz)	Frequency Range (MHz)	Maximum EIRP(W)	Emission Designator (99%OBW)	Maximum EIRP(W)	Emission Designator (99%OBW)
20	3460.02 ~ 3540.00	0.2636	18M1G7D	0.1986	18M2W7D
30	3465.00 ~ 3534.99	0.2547	-	0.1923	-
40	3470.01 ~ 3529.98	0.2523	-	0.1941	-
50	3475.02 ~ 3525.00	0.2559	-	0.1954	-
60	3480.00 ~ 3519.99	0.2559	-	0.1923	-
80	3490.02 ~ 3510.00	0.2535	-	0.1849	-
90	3495.00 ~ 3504.99	0.2483	-	0.1858	-
100	3500.01	0.2655	-	0.2014	-

Note: only 20M BW and Power/EIRP/RSE are assessed in this report, all the other test results are leveraged from original report FG351205K which is issued separately.

1.7 Testing Site

Sporton International Inc. (Kunshan) is accredited to ISO/IEC 17025:2017 by American Association for Laboratory Accreditation with Certificate Number 5145.02.

Test Firm	Sporton International Inc. (Kunshan)		
Test Site Location	No. 1098, Pengxi North Road, Kunshan Economic Development Zone Jiangsu Province 215300 People's Republic of China TEL : +86-512-57900158		
Test Site No.	Sporton Site No.	FCC Designation No.	FCC Test Firm Registration No.
	TH01-KS 03CH04-KS	CN1257	314309

1.8 Test Software

Item	Site	Manufacturer	Name	Version
1.	03CH04-KS	AUDIX	E3	6.2009-8-24a1

1.9 Applied Standards

According to the specifications of the manufacturer, the EUT must comply with the requirements of the following standards:

- ♦ 47 CFR Part 2, Part 27 Subpart Q
- ♦ ANSI C63.26-2015
- ♦ FCC KDB 971168 Power Meas License Digital Systems D01 v03r01
- ♦ FCC KDB 412172 D01 Determining ERP and EIRP v01r01

Remark:

1. All test items were verified and recorded according to the standards and without any deviation during the test.
2. This EUT has also been tested and complied with the requirements of FCC Part 15, Subpart B, recorded in a separate test report.

2 Test Configuration of Equipment Under Test

2.1 Test Mode

Antenna port conducted and radiated test items listed below are performed according to KDB 971168 D01 Power Meas. License Digital Systems v03r01 with maximum output power.

Radiated measurements are performed by rotating the EUT in three different orthogonal test planes to find the maximum emission.

Test Cases	Band	Bandwidth (MHz)	Modulation	RB #	Test Channel
		eg. 5M, 10M, 15M, 20M	eg. PI/2 BPSK, QPSK, 16QAM, 64QAM, 256QAM	1RB, Partial RB, Full RB	L/M/H
Max. Output Power	5G n77	20M, 30M, 40M, 50M, 60M, 80M, 90M ,100M	All Modulations	1RB, Full RB	L, M, H
	5G n78	20M, 30M, 40M, 50M, 60M, 80M, 90M ,100M	All Modulations	1RB, Full RB	L, M, H
Peak-to-Average Ratio	5G n77/78	20M	PI/2 BPSK, QPSK	1RB, Full RB	M
E.I.R.P	5G n77	20M, 30M, 40M, 50M, 60M, 80M, 90M ,100M	All Modulations	1RB, Full RB	L, M, H
	5G n78	20M, 30M, 40M, 50M, 60M, 80M, 90M ,100M	All Modulations	1RB, Full RB	L, M, H
26dB and 99% Bandwidth	5G n77/78	20M	All Modulations	Full RB	M
Conducted Band Edge	5G n77/78	20M	PI/2 BPSK, QPSK	1RB, Full RB	L, H
Conducted Spurious Emission	5G n77/78	20M	PI/2 BPSK, QPSK	1RB	L, M, H
Frequency Stability	5G n77/78	20M	QPSK	Full RB	M
Radiated Spurious Emission	5G n77	Worst case from maximum power			M

Note:

1. The device is investigated from 30MHz to 10 times of fundamental signal for radiated spurious emission test under different RB size/offset and modulations in exploratory test. Subsequently, only the worst case emissions are reported.
2. 5G NR Band n77 overlaps the entire frequency range of Band n78, and n77power > n78 power, therefore the Radiated Spurious Emission test results of n77 provided in this report cover n78
3. Frequency Stability: Normal Voltage = 3.88V; Low Voltage =3.60V; High Voltage =4.47V.
4. All test items are based on engineering evaluation.

2.2 Connection Diagram of Test System

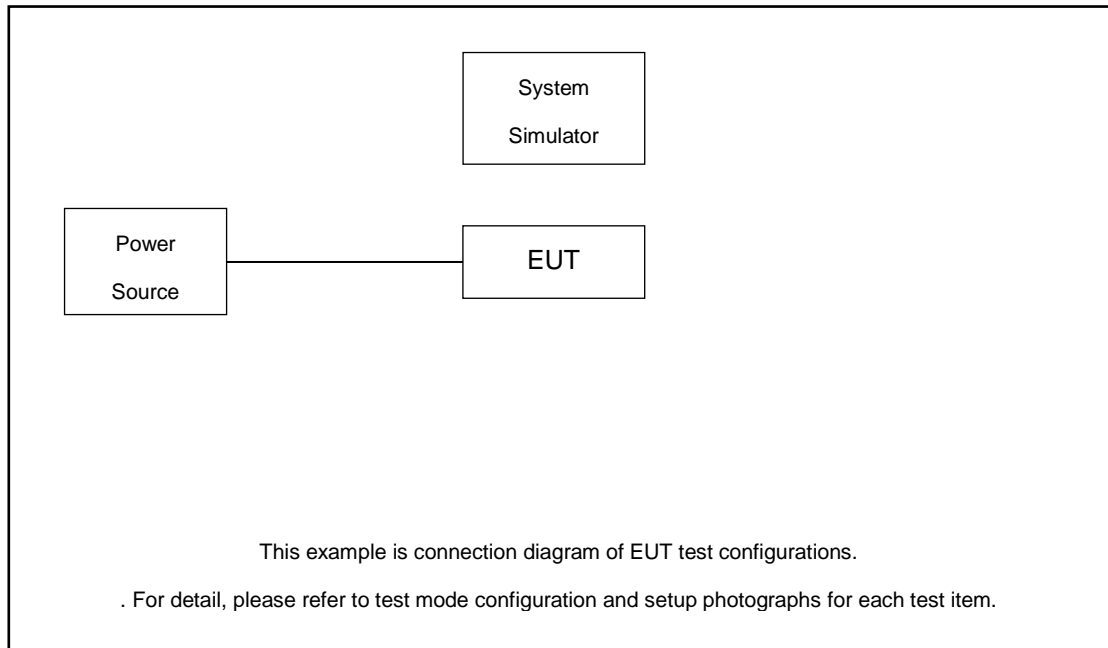

2.3 Support Unit used in test configuration and system

Item	Equipment	Trade Name	Model No.	FCC ID	Data Cable	Power Cord
1.	Power Supply	GWINSTEK	PSS-2002	N/A	N/A	Unshielded, 1.8 m
2.	NR Base Station	Anritsu	MT8000A	N/A	N/A	Unshielded, 1.8 m

2.4 Measurement Results Explanation Example

For all conducted test items:

The offset level is set in the spectrum analyzer to compensate the RF cable loss and attenuator factor between EUT conducted output port and spectrum analyzer. With the offset compensation, the spectrum analyzer reading level is exactly the EUT RF output level.

The spectrum analyzer offset is derived from RF cable loss and attenuator factor.

Offset = RF cable loss + attenuator factor.

Following shows an offset computation example with cable loss 3.49 dB and 10dB attenuator.

Example :

$$\begin{aligned} \text{Offset(dB)} &= \text{RF cable loss(dB)} + \text{attenuator factor(dB)}. \\ &= 3.49 + 10 = 13.49 \text{ (dB)} \end{aligned}$$

2.5 Frequency List of Low/Middle/High Channels

5G n77/n78 Channel and Frequency List				
BW [MHz]	Channel/Frequency(MHz)	Lowest	Middle	Highest
100	Channel	-	633334	-
	Frequency	-	3500.01	-
90	Channel	633000	633334	633666
	Frequency	3495	3500.01	3504.99
80	Channel	632668	633334	634000
	Frequency	3490.02	3500.01	3510
60	Channel	632000	633334	634666
	Frequency	3480	3500.01	3519.99
50	Channel	631668	633334	635000
	Frequency	3475.02	3500.01	3525
40	Channel	631334	633334	635332
	Frequency	3470.01	3500.01	3529.98
30	Channel	631000	633334	635666
	Frequency	3465	3500.01	3534.99
20	Channel	630668	633334	636000
	Frequency	3460.02	3500.01	3540

3 Conducted Test Items

3.1 Measuring Instruments

See list of measuring instruments of this test report.

3.2 Test Setup

3.2.1 Conducted Output Power

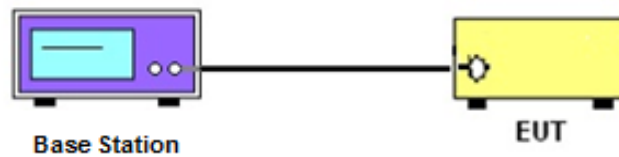

3.2.2 Peak-to-Average Ratio, Occupied / 26dB Bandwidth, Band-Edge and Conducted Spurious Emission

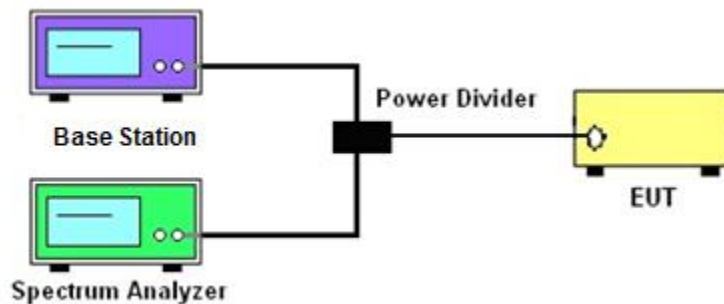

3.2.3 Frequency Stability

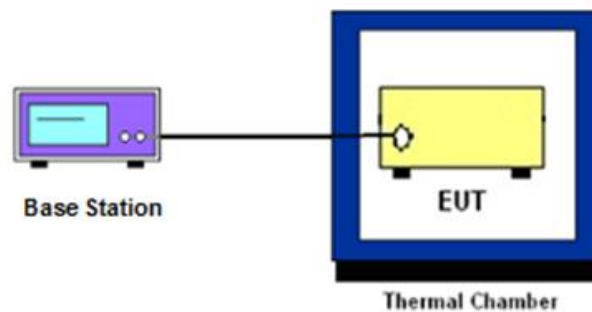

3.3 Test Result of Conducted Test

Please refer to Appendix A.

3.4 Conducted Output Power Measurement

3.4.1 Description of the Conducted Output Power Measurement

A base station simulator was used to establish communication with the EUT. Its parameters were set to transmit the maximum power on the EUT. The measured power in the radio frequency on the transmitter output terminals shall be reported.

3.4.2 Test Procedures

1. The testing follows ANSI C63.26 Section 5.2
2. The transmitter output port was connected to the system simulator.
3. Set EUT at maximum power through the system simulator.
4. Select lowest, middle, and highest channels for each band and different modulation.
5. Measure and record the power level from the system simulator.

3.5 Peak-to-Average Ratio

3.5.1 Description of the PAR Measurement

Power Complementary Cumulative Distribution Function (CCDF) curves provide a means for characterizing the power peaks of a digitally modulated signal on a statistical basis. A CCDF curve depicts the probability of the peak signal amplitude exceeding the average power level. Most contemporary measurement instrumentation include the capability to produce CCDF curves for an input signal provided that the instrument's resolution bandwidth can be set wide enough to accommodate the entire input signal bandwidth. In measuring transmissions in this band using an average power technique, the peak-to-average ratio (PAR) of the transmission may not exceed 13 dB.

3.5.2 Test Procedures

1. The testing follows ANSI C63.26 Section 5.2.3.4 (CCDF).
2. The EUT was connected to spectrum and system simulator via a power divider.
3. Set the CCDF (Complementary Cumulative Distribution Function) option in spectrum analyzer.
4. The highest RF powers were measured and recorded the maximum PAPR level associated with a probability of 0.1 %.
5. Record the deviation as Peak to Average Ratio.

3.6 EIRP

3.6.1 Description of EIRP Limit

§ 27.50 (k)(3)

Mobile devices are limited to 1Watt (30 dBm) EIRP. Mobile devices operating in these bands must employ a means for limiting power to the minimum necessary for successful communications

3.6.2 Test Procedures

1. According to KDB 412172 D01 Power Approach,
2. $EIRP = P_T + G_T - L_C$, $ERP = EIRP - 2.15$, where
 P_T = transmitter output power in dBm
 G_T = gain of the transmitting antenna in dBi
 L_C = signal attenuation in the connecting cable between the transmitter and antenna in dB

3.7 Occupied Bandwidth

3.7.1 Description of Occupied Bandwidth Measurement

The occupied bandwidth is the width of a frequency band such that, below the lower and above the upper frequency limits, the mean powers emitted are each equal to a specified percentage 0.5% of the total mean transmitted power.

The 26 dB emission bandwidth is defined as the frequency range between two points, one above and one below the carrier frequency, at which the spectral density of the emission is attenuated 26 dB below the maximum in-band spectral density of the modulated signal. Spectral density (power per unit bandwidth) is to be measured with a detector of resolution bandwidth equal to approximately 1.0% of the emission bandwidth.

3.7.2 Test Procedures

1. The testing follows ANSI C63.26 Section 5.4
2. The EUT was connected to spectrum analyzer and system simulator via a power divider.
3. The spectrum analyzer center frequency is set to the nominal EUT channel center frequency. The span range for the spectrum analyzer shall be between two and five times the anticipated OBW.
4. The nominal resolution bandwidth (RBW) shall be in the range of 1 to 5 % of the anticipated OBW, and the VBW shall be at least 3 times the RBW.
5. Set the detection mode to peak, and the trace mode to max hold.
6. Determine the reference value: Set the EUT to transmit a modulated signal. Allow the trace to stabilize. Set the spectrum analyzer marker to the highest level of the displayed trace.
(this is the reference value)
7. Determine the “-26 dB down amplitude” as equal to (Reference Value – X).
8. Place two markers, one at the lowest and the other at the highest frequency of the envelope of the spectral display such that each marker is at or slightly below the “-X dB down amplitude” determined in step 6. If a marker is below this “-X dB down amplitude” value it shall be placed as close as possible to this value. The OBW is the positive frequency difference between the two markers.
9. Use the 99 % power bandwidth function of the spectrum analyzer and report the measured bandwidth.

3.8 Conducted Band Edge Measurement

3.8.1 Description of Conducted Band Edge Measurement

§ 27.53 (n)(2)

For mobile operations in the 3450-3550 MHz band, the conducted power of any emission outside the licensee's authorized bandwidth shall not exceed -13 dBm/MHz.

Compliance with this paragraph is based on the use of measurement instrumentation employing a resolution bandwidth of 1 megahertz or greater. However, in the 1 megahertz bands immediately outside and adjacent to the licensee's frequency block, a resolution bandwidth of at least one percent of the emission bandwidth of the fundamental emission of the transmitter may be employed, but limited to a maximum of 200 kHz. In the bands between 1 and 5 MHz removed from the licensee's frequency block, the minimum resolution bandwidth for the measurement shall be 500 kHz.

3.8.2 Test Procedures

1. The testing follows ANSI C63.26 section 5.7
2. The EUT was connected to spectrum analyzer and system simulator via a power divider.
3. The band edges of low and high channels for the highest RF powers were measured.
4. Set RBW $\geq 1\%$ EBW but limited to a maximum of 200 kHz in the 1MHz band immediately outside and adjacent to the band edge.
5. Beyond the 1 MHz and 5 MHz removed from the band edge, set RBW ≥ 500 KHz.
6. Beyond the 5 MHz removed from the band edge, set RBW = 1MHz.
7. Set spectrum analyzer with RMS detector.
8. The RF fundamental frequency should be excluded against the limit line in the operating frequency band.
9. Checked that all the results comply with the emission limit line.

3.9 Conducted Spurious Emission Measurement

3.9.1 Description of Conducted Spurious Emission Measurement

The power of any emission outside of the authorized operating frequency ranges shall not exceed -13 dBm/MHz.

It is measured by means of a calibrated spectrum analyzer and scanned from 9 kHz up to a frequency including its 10th harmonic.

3.9.2 Test Procedures

1. The testing follows ANSI C63.26 section 5.7
2. The EUT was connected to spectrum analyzer and system simulator via a power divider.
3. The RF output of EUT was connected to the spectrum analyzer by RF cable and attenuator. The path loss was compensated to the results for each measurement.
4. The middle channel for the highest RF power within the transmitting frequency was measured.
5. The conducted spurious emission for the whole frequency range was taken.
6. Make the measurement with the spectrum analyzer's RBW = 1MHz, VBW = 3MHz.
7. Set spectrum analyzer with RMS detector.
8. Taking the record of maximum spurious emission.
9. The RF fundamental frequency should be excluded against the limit line in the operating frequency band.
10. Checked that all the results comply with the emission limit line.

3.10 Frequency Stability Measurement

3.10.1 Description of Frequency Stability Measurement

The frequency stability shall be measured by variation of ambient temperature and variation of primary supply voltage to ensure that the fundamental emission stays within the authorized frequency block.

3.10.2 Test Procedures for Temperature Variation

1. The testing follows ANSI C63.26 section 5.6.4
2. The EUT was set up in the thermal chamber and connected with the system simulator.
3. With power OFF, the temperature was decreased to -30°C and the EUT was stabilized before testing. Power was applied and the maximum change in frequency was recorded within one minute.
4. With power OFF, the temperature was raised in 10°C step up to 50°C . The EUT was stabilized at each step for at least half an hour. Power was applied and the maximum frequency change was recorded within one minute.

3.10.3 Test Procedures for Voltage Variation

1. The testing follows ANSI C63.26 section 5.6.5.
2. The EUT was placed in a temperature chamber at $20\pm 5^{\circ}\text{C}$ and connected with the system simulator.
3. The power supply voltage to the EUT was varied from 85% to 115% of the nominal value for other than hand carried battery equipment.
4. For hand carried, battery powered equipment, reduce the primary ac or dc supply voltage to the battery operating end point, which shall be specified by the manufacturer.
5. The variation in frequency was measured for the worst case.

4 Radiated Test Items

4.1 Measuring Instruments

See list of measuring instruments of this test report.

4.2 Test Setup

4.2.1 For radiated test below 30MHz

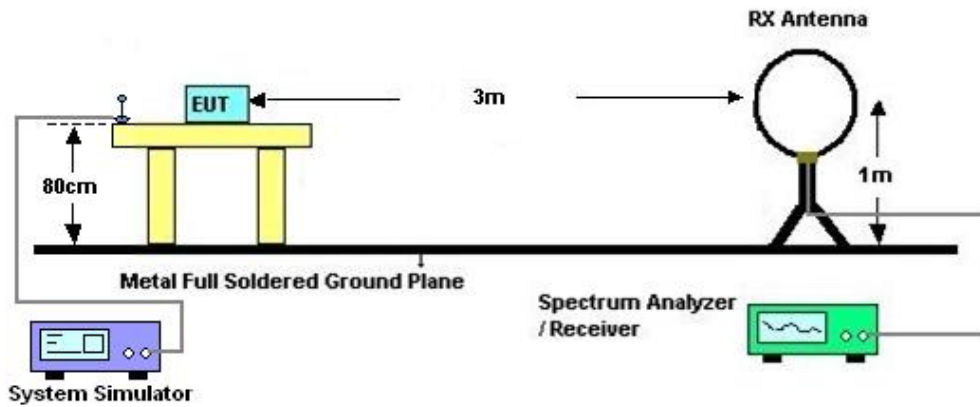

4.2.2 For radiated test from 30MHz to 1GHz

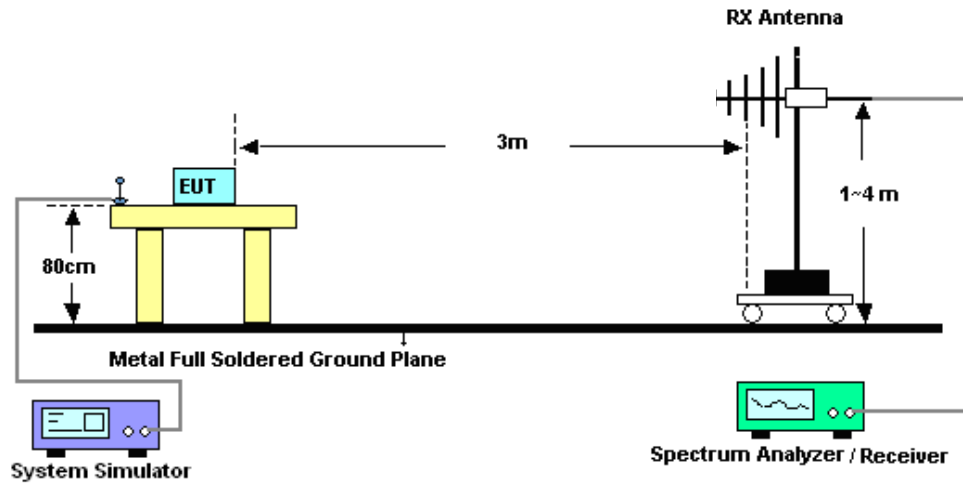

4.2.3 For radiated test above 1GHz

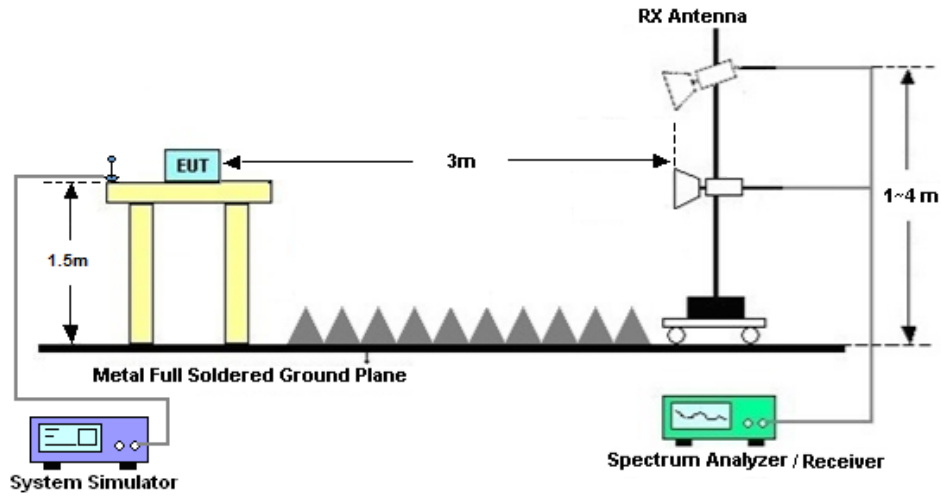

4.3 Test Result of Radiated Test

The low frequency, which started from 9 kHz to 30MHz, was pre-scanned and the result which was 20dB lower than the limit line was not reported.

Please refer to Appendix B.

4.4 Radiated Spurious Emission Measurement

4.4.1 Description of Radiated Spurious Emission

The radiated spurious emission was measured by substitution method according to ANSI/TIA-603-E. The power of any emission outside of the authorized operating frequency ranges shall not exceed -13 dBm/MHz.

The spectrum is scanned from 30 MHz up to a frequency including its 10th harmonic.

4.4.2 Test Procedures

6. The testing follows ANSI C63.26 Section 5.5
7. The EUT was placed on a turntable with 0.8 meter height for frequency below 1GHz and 1.5 meter height for frequency above 1GHz respectively above ground.
8. The EUT was set 3 meters from the receiving antenna mounted on the antenna tower.
9. The table was rotated 360 degrees to determine the position of the highest spurious emission.
10. The height of the receiving antenna is varied between 1m to 4m to search the maximum spurious emission for both horizontal and vertical polarizations.
11. During the measurement, the system simulator parameters were set to force the EUT transmitting at maximum output power.
12. Make the measurement with the spectrum analyzer's RBW = 1MHz, VBW = 3MHz, taking the record of maximum spurious emission.
13. A horn antenna was substituted in place of the EUT and was driven by a signal generator.
14. Tune the output power of signal generator to the same emission level with EUT maximum spurious emission.
$$\text{EIRP (dBm)} = \text{S.G. Power} - \text{Tx Cable Loss} + \text{Tx Antenna Gain}$$
$$\text{ERP (dBm)} = \text{EIRP} - 2.15$$
15. The RF fundamental frequency should be excluded against the limit line in the operating frequency band.



5 List of Measuring Equipment

Instrument	Manufacturer	Model No.	Serial No.	Characteristics	Calibration Date	Test Date	Due Date	Remark
Spectrum Analyzer	R&S	FSV40	101040	10Hz~40GHz	Oct. 12, 2022	Jun. 14, 2023	Oct. 11, 2023	Conducted (TH01-KS)
Power divider	STI	STI08-0055	-	0.5~40GHz	/	Jun. 14, 2023	/	Conducted (TH01-KS)
Temperature & humidity chamber	Hongzhan	LP-150U	H2014011440	-40~+150°C 20%~95%RH	Jul. 15, 2022	Jun. 14, 2023	Jul. 14, 2023	Conducted (TH01-KS)
EMI Test Receiver	Keysight	N9038A	MY56400004	3Hz~8.5GHz;Max 30dBm	Oct. 13, 2022	Jul. 19, 2023	Oct. 12, 2023	Radiation (03CH04-KS)
EXA Spectrum Analyzer	Keysight	N9010B	MY57471079	10Hz-44G,MAX 30dB	Oct. 12, 2022	Jul. 19, 2023	Oct. 11, 2023	Radiation (03CH04-KS)
Loop Antenna	R&S	HFH2-Z2E	101125	9kHz~30MHz	Sep. 22, 2022	Jul. 19, 2023	Sep. 21, 2023	Radiation (03CH04-KS)
Bilog Antenna	TeseQ	CBL6111D	49922	30MHz-1GHz	Apr. 09, 2023	Jul. 19, 2023	Apr. 08, 2024	Radiation (03CH04-KS)
Horn Antenna	Schwarzbeck	BBHA9120D	1284	1GHz~18GHz	Oct. 16, 2022	Jul. 19, 2023	Oct. 15, 2023	Radiation (03CH04-KS)
SHF-EHF Horn	Com-power	AH-840	101070	18GHz~40GHz	Jan. 08, 2023	Jul. 19, 2023	Jan. 07, 2024	Radiation (03CH04-KS)
Amplifier	SONOMA	310N	380827	9KHz-1GHz	Jul. 10, 2023	Jul. 19, 2023	Jul. 09, 2024	Radiation (03CH04-KS)
Amplifier	MITEQ	EM18G40G GA	060728	18~40GHz	Jan. 05, 2023	Jul. 19, 2023	Jan. 04, 2024	Radiation (03CH04-KS)
high gain Amplifier	EM	EM01G18G A	060840	1Ghz-18Ghz	Oct. 12, 2022	Jul. 19, 2023	Oct. 11, 2023	Radiation (03CH04-KS)
Amplifier	Agilent	8449B	3008A02370	1Ghz-18Ghz	Oct. 12, 2022	Jul. 19, 2023	Oct. 11, 2023	Radiation (03CH04-KS)
AC Power Source	Chroma	61601	F104090004	N/A	NCR	Jul. 19, 2023	NCR	Radiation (03CH04-KS)
Turn Table	ChamPro	EM 1000-T	060762-T	0~360 degree	NCR	Jul. 19, 2023	NCR	Radiation (03CH04-KS)
Antenna Mast	ChamPro	EM 1000-A	060762-A	1 m~4 m	NCR	Jul. 19, 2023	NCR	Radiation (03CH04-KS)

NCR: No Calibration Required

6 Measurement Uncertainty

The measurement uncertainties shown below were calculated in accordance with the requirements of ANSI 63.26-2015. All the measurement uncertainty value were shown with a coverage K=2 to indicate 95% level of confidence. The measurement data show herein meets or exceeds the CISPR measurement uncertainty values specified in CISPR 16-4-2 and can be compared directly to specified limit to determine compliance.

Uncertainty of Conducted Measurement

Test Item	Uncertainty
Conducted Power	±0.46 dB
Conducted Emissions	±2.26 dB
Occupied Channel Bandwidth	±0.1 %

Uncertainty of Radiated Emission Measurement (30 MHz ~ 1000 MHz)

Measuring Uncertainty for a Level of Confidence of 95% (U = 2Uc(y))	3.82dB
---	--------

Uncertainty of Radiated Emission Measurement (1 GHz ~ 18 GHz)

Measuring Uncertainty for a Level of Confidence of 95% (U = 2Uc(y))	3.56dB
---	--------

Uncertainty of Radiated Emission Measurement (18 GHz ~ 40 GHz)

Measuring Uncertainty for a Level of Confidence of 95% (U = 2Uc(y))	3.54dB
---	--------

----- THE END -----



Appendix A. Test Results of Conducted Test

Test Engineer :	Simle Wang	Temperature :	22~23°C
		Relative Humidity :	40~42%

FR1 N77 (ANT5)

Transmitter Conducted Output Power And EIRP, (G_T - L_C)=-0.26dBi

NR Band	SCS	Band Width	Arfcn	Freq(MHz)	Modulation	RB	Conducted Power(dBm)	EIRP(dBm)	EIRP(W)
77	30	100	633334	3500.01	DFT-s-OFDM PI/2 BPSK	135@67	24.63	24.37	0.2735
77	30	100	633334	3500.01	DFT-s-OFDM PI/2 BPSK	1@1	24.74	24.48	0.2805
77	30	100	633334	3500.01	DFT-s-OFDM PI/2 BPSK	1@27 1	24.21	23.95	0.2483
77	30	100	633334	3500.01	DFT-s-OFDM QPSK	135@67	24.63	24.37	0.2735
77	30	100	633334	3500.01	DFT-s-OFDM QPSK	1@1	24.56	24.3	0.2692
77	30	100	633334	3500.01	DFT-s-OFDM QPSK	1@27 1	24.14	23.88	0.2443
77	30	100	633334	3500.01	DFT-s-OFDM 16 QAM	135@67	23.65	23.39	0.2183
77	30	100	633334	3500.01	DFT-s-OFDM 16 QAM	1@1	23.44	23.18	0.2080
77	30	100	633334	3500.01	DFT-s-OFDM 16 QAM	1@27 1	23.01	22.75	0.1884
77	30	100	633334	3500.01	DFT-s-OFDM 64 QAM	135@67	22.13	21.87	0.1538
77	30	100	633334	3500.01	DFT-s-OFDM 64 QAM	1@1	22.47	22.21	0.1663
77	30	100	633334	3500.01	DFT-s-OFDM 64 QAM	1@27 1	21.93	21.67	0.1469
77	30	100	633334	3500.01	DFT-s-OFDM 256 QAM	135@67	20.12	19.86	0.0968
77	30	100	633334	3500.01	DFT-s-OFDM 256 QAM	1@1	19.98	19.72	0.0938
77	30	100	633334	3500.01	DFT-s-OFDM 256 QAM	1@27 1	19.56	19.3	0.0851
77	30	100	633334	3500.01	CP-OFDM QPSK	137@68	23.13	22.87	0.1936
77	30	100	633334	3500.01	CP-OFDM QPSK	1@1	23.1	22.84	0.1923
77	30	100	633334	3500.01	CP-OFDM QPSK	1@27 1	22.64	22.38	0.1730
77	30	20	630668	3460.02	DFT-s-OFDM PI/2 BPSK	1@1	24.65	24.39	0.2748
77	30	20	630668	3460.02	DFT-s-OFDM QPSK	1@1	24.66	24.4	0.2754
77	30	20	630668	3460.02	DFT-s-OFDM 16 QAM	1@1	23.47	23.21	0.2094
77	30	20	633334	3500.01	DFT-s-OFDM PI/2 BPSK	1@1	24.68	24.42	0.2767
77	30	20	633334	3500.01	DFT-s-OFDM QPSK	1@1	24.62	24.36	0.2729
77	30	20	633334	3500.01	DFT-s-OFDM 16 QAM	1@1	23.47	23.21	0.2094
77	30	20	636000	3540	DFT-s-OFDM PI/2 BPSK	1@1	24.72	24.46	0.2793
77	30	20	636000	3540	DFT-s-OFDM QPSK	1@1	24.71	24.45	0.2786
77	30	20	636000	3540	DFT-s-OFDM 16 QAM	1@1	23.48	23.22	0.2099
77	30	30	631000	3465	DFT-s-OFDM PI/2 BPSK	1@1	24.55	24.29	0.2685
77	30	30	631000	3465	DFT-s-OFDM	1@1	24.52	24.26	0.2667

QPSK									
77	30	30	631000	3465	DFT-s-OFDM 16 QAM	1@1	23.35	23.09	0.2037
77	30	30	633334	3500.01	DFT-s-OFDM PI/2 BPSK	1@1	24.55	24.29	0.2685
77	30	30	633334	3500.01	DFT-s-OFDM QPSK	1@1	24.56	24.3	0.2692
77	30	30	633334	3500.01	DFT-s-OFDM 16 QAM	1@1	23.32	23.06	0.2023
77	30	30	635666	3534.99	DFT-s-OFDM PI/2 BPSK	1@1	24.6	24.34	0.2716
77	30	30	635666	3534.99	DFT-s-OFDM QPSK	1@1	24.55	24.29	0.2685
77	30	30	635666	3534.99	DFT-s-OFDM 16 QAM	1@1	23.28	23.02	0.2004
77	30	40	631334	3470.01	DFT-s-OFDM PI/2 BPSK	1@1	24.58	24.32	0.2704
77	30	40	631334	3470.01	DFT-s-OFDM QPSK	1@1	24.53	24.27	0.2673
77	30	40	631334	3470.01	DFT-s-OFDM 16 QAM	1@1	23.35	23.09	0.2037
77	30	40	633334	3500.01	DFT-s-OFDM PI/2 BPSK	1@1	24.53	24.27	0.2673
77	30	40	633334	3500.01	DFT-s-OFDM QPSK	1@1	24.49	24.23	0.2649
77	30	40	633334	3500.01	DFT-s-OFDM 16 QAM	1@1	23.35	23.09	0.2037
77	30	40	635332	3529.98	DFT-s-OFDM PI/2 BPSK	1@1	24.57	24.31	0.2698
77	30	40	635332	3529.98	DFT-s-OFDM QPSK	1@1	24.55	24.29	0.2685
77	30	40	635332	3529.98	DFT-s-OFDM 16 QAM	1@1	23.43	23.17	0.2075
77	30	50	631668	3475.02	DFT-s-OFDM PI/2 BPSK	1@1	24.62	24.36	0.2729
77	30	50	631668	3475.02	DFT-s-OFDM QPSK	1@1	24.58	24.32	0.2704
77	30	50	631668	3475.02	DFT-s-OFDM 16 QAM	1@1	23.38	23.12	0.2051
77	30	50	633334	3500.01	DFT-s-OFDM PI/2 BPSK	1@1	24.49	24.23	0.2649
77	30	50	633334	3500.01	DFT-s-OFDM QPSK	1@1	24.44	24.18	0.2618
77	30	50	633334	3500.01	DFT-s-OFDM 16 QAM	1@1	23.29	23.03	0.2009
77	30	50	635000	3525	DFT-s-OFDM PI/2 BPSK	1@1	24.66	24.4	0.2754
77	30	50	635000	3525	DFT-s-OFDM QPSK	1@1	24.67	24.41	0.2761
77	30	50	635000	3525	DFT-s-OFDM 16 QAM	1@1	23.39	23.13	0.2056
77	30	60	632000	3480	DFT-s-OFDM PI/2 BPSK	1@1	24.63	24.37	0.2735
77	30	60	632000	3480	DFT-s-OFDM QPSK	1@1	24.6	24.34	0.2716
77	30	60	632000	3480	DFT-s-OFDM 16 QAM	1@1	23.29	23.03	0.2009
77	30	60	633334	3500.01	DFT-s-OFDM PI/2 BPSK	1@1	24.46	24.2	0.2630
77	30	60	633334	3500.01	DFT-s-OFDM QPSK	1@1	24.4	24.14	0.2594
77	30	60	633334	3500.01	DFT-s-OFDM 16 QAM	1@1	23.25	22.99	0.1991
77	30	60	634666	3519.99	DFT-s-OFDM PI/2 BPSK	1@1	24.62	24.36	0.2729
77	30	60	634666	3519.99	DFT-s-OFDM QPSK	1@1	24.64	24.38	0.2742

77	30	60	634666	3519.99	DFT-s-OFDM 16 QAM	1@1	23.48	23.22	0.2099
77	30	80	632668	3490.02	DFT-s-OFDM PI/2 BPSK	1@1	24.52	24.26	0.2667
77	30	80	632668	3490.02	DFT-s-OFDM QPSK	1@1	24.57	24.31	0.2698
77	30	80	632668	3490.02	DFT-s-OFDM 16 QAM	1@1	23.26	23	0.1995
77	30	80	633334	3500.01	DFT-s-OFDM PI/2 BPSK	1@1	24.44	24.18	0.2618
77	30	80	633334	3500.01	DFT-s-OFDM QPSK	1@1	24.47	24.21	0.2636
77	30	80	633334	3500.01	DFT-s-OFDM 16 QAM	1@1	23.16	22.9	0.1950
77	30	80	634000	3510	DFT-s-OFDM PI/2 BPSK	1@1	24.43	24.17	0.2612
77	30	80	634000	3510	DFT-s-OFDM QPSK	1@1	24.49	24.23	0.2649
77	30	80	634000	3510	DFT-s-OFDM 16 QAM	1@1	23.14	22.88	0.1941
77	30	90	633000	3495	DFT-s-OFDM PI/2 BPSK	1@1	24.48	24.22	0.2642
77	30	90	633000	3495	DFT-s-OFDM QPSK	1@1	24.53	24.27	0.2673
77	30	90	633000	3495	DFT-s-OFDM 16 QAM	1@1	23.16	22.9	0.1950
77	30	90	633334	3500.01	DFT-s-OFDM PI/2 BPSK	1@1	24.45	24.19	0.2624
77	30	90	633334	3500.01	DFT-s-OFDM QPSK	1@1	24.52	24.26	0.2667
77	30	90	633334	3500.01	DFT-s-OFDM 16 QAM	1@1	23.01	22.75	0.1884
77	30	90	633666	3504.99	DFT-s-OFDM PI/2 BPSK	1@1	24.41	24.15	0.2600
77	30	90	633666	3504.99	DFT-s-OFDM QPSK	1@1	24.48	24.22	0.2642
77	30	90	633666	3504.99	DFT-s-OFDM 16 QAM	1@1	23.18	22.92	0.1959

Frequency Stability

NR Band	SCS (kHz)	Bandwidth (MHz)	Arfcn	Freq (MHz)	Modulation	RB	Deviation (ppm)	Verdict	Environment
77	30	20	633334	3500.01	DFT-s-OFDM QPSK	50@0	0.0016	PASS	NV
77	30	20	633334	3500.01	DFT-s-OFDM QPSK	50@0	0.0035	PASS	LV
77	30	20	633334	3500.01	DFT-s-OFDM QPSK	50@0	-0.0028	PASS	HV
77	30	20	633334	3500.01	DFT-s-OFDM QPSK	50@0	0.0025	PASS	-30°C
77	30	20	633334	3500.01	DFT-s-OFDM QPSK	50@0	0.0024	PASS	-20°C
77	30	20	633334	3500.01	DFT-s-OFDM QPSK	50@0	0.0018	PASS	-10°C
77	30	20	633334	3500.01	DFT-s-OFDM QPSK	50@0	-0.0023	PASS	0°C
77	30	20	633334	3500.01	DFT-s-OFDM QPSK	50@0	0.0037	PASS	10°C
77	30	20	633334	3500.01	DFT-s-OFDM QPSK	50@0	0.0028	PASS	20°C
77	30	20	633334	3500.01	DFT-s-OFDM QPSK	50@0	-0.0022	PASS	30°C
77	30	20	633334	3500.01	DFT-s-OFDM QPSK	50@0	0.0031	PASS	40°C
77	30	20	633334	3500.01	DFT-s-OFDM QPSK	50@0	0.0012	PASS	50°C

Peak to Average Ratio

NR Band	SCS (kHz)	Bandwidth (MHz)	Arfcn	Freq (MHz)	Modulation	RB	Result (dB)	Limit (dB)	Verdict
77	30	20	633334	3500.01	DFT-s-OFDM PI/2 BPSK	50@0	7.21	13	PASS
77	30	20	633334	3500.01	DFT-s-OFDM PI/2 BPSK	1@0	7.25	13	PASS
77	30	20	633334	3500.01	DFT-s-OFDM QPSK	50@0	8.34	13	PASS
77	30	20	633334	3500.01	DFT-s-OFDM QPSK	1@0	7.79	13	PASS

N77(20M)_DFT-s-OFDM_PI_2-BPSK_Outer_Full_Mid_CH

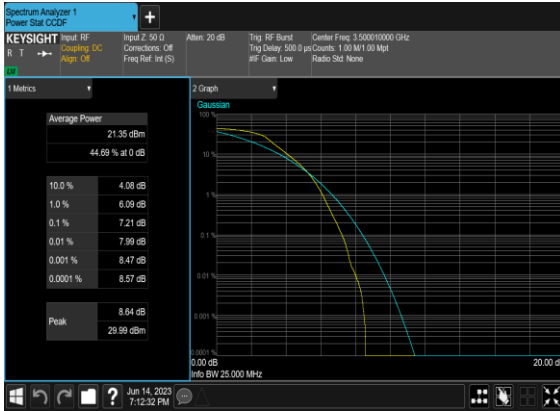

N77(20M)_DFT-s-OFDM_PI_2-BPSK_Edge_1RB_Left_Mid_CH

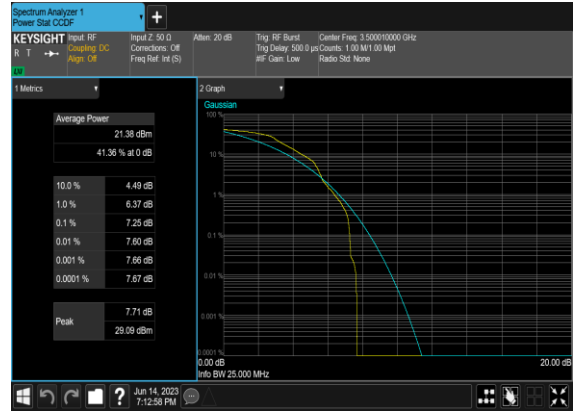

N77(20M)_DFT-s-OFDM_QPSK_Outer_Full_Mid_CH

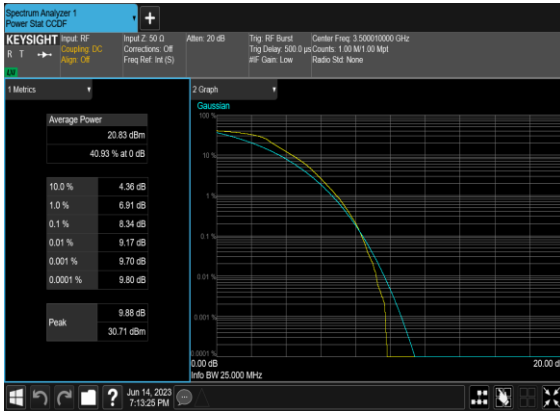

N77(20M)_DFT-s-OFDM_QPSK_Edge_1RB_Left_Mid_CH

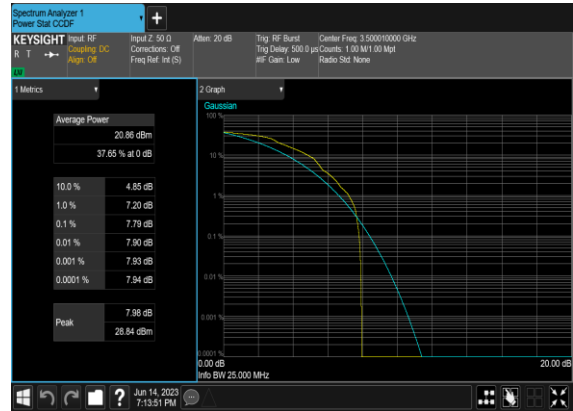

Occupied Bandwidth

NR Band	SCS (kHz)	Bandwidth (MHz)	Arfcn	Freq (MHz)	Modulation	RB	OBW (MHz)	26dB BW (MHz)
77	30	20	633334	3500.01	CP-OFDM QPSK	51@0	18.226	19.02
77	30	20	633334	3500.01	CP-OFDM 16 QAM	51@0	18.239	19.01
77	30	20	633334	3500.01	CP-OFDM 64 QAM	51@0	18.218	18.86
77	30	20	633334	3500.01	CP-OFDM 256 QAM	51@0	18.164	18.87

N77(20M)_CP-OFDM_QPSK_Outer_Full_Mid_CH

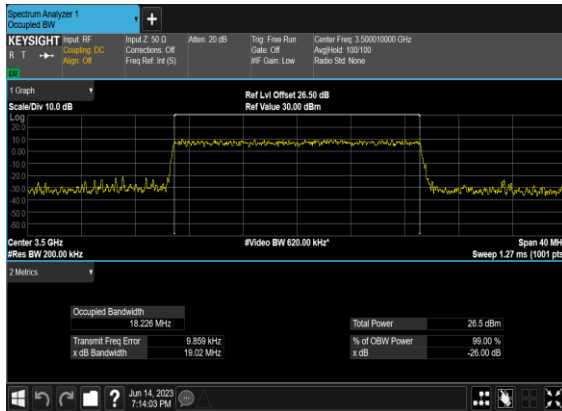

N77(20M)_CP-OFDM_16QAM_Outer_Full_Mid_CH

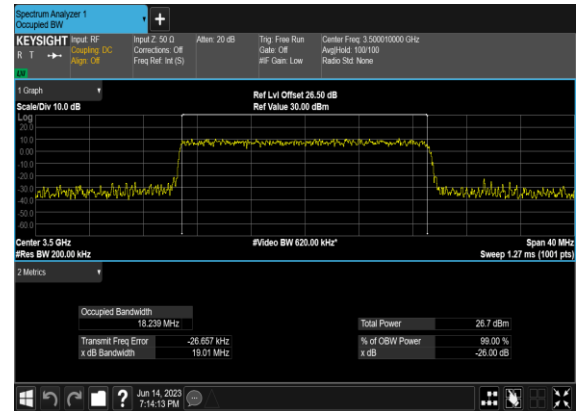

N77(20M)_CP-OFDM_64QAM_Outer_Full_Mid_CH

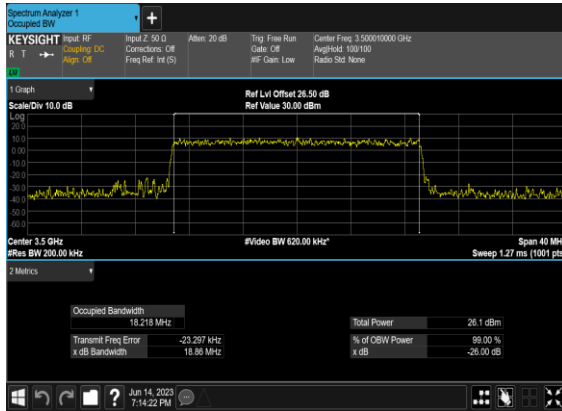

N77(20M)_CP-OFDM_256QAM_Outer_Full_Mid_CH

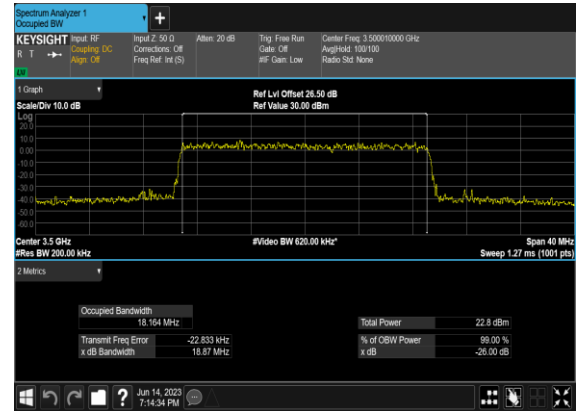

Conducted Spurious Emissions

NR Band	SCS (kHz)	Bandwidth (MHz)	Arfcn	Freq (MHz)	Modulation	RB	Result	Verdict
77	30	20	630668	3460.02	DFT-s-OFDM BPSK	1@0	see graph	---
77	30	20	630668	3460.02	DFT-s-OFDM BPSK	1@0	see graph	PASS
77	30	20	630668	3460.02	DFT-s-OFDM BPSK	1@0	see graph	PASS
77	30	20	630668	3460.02	DFT-s-OFDM QPSK	1@0	see graph	---
77	30	20	630668	3460.02	DFT-s-OFDM QPSK	1@0	see graph	PASS
77	30	20	630668	3460.02	DFT-s-OFDM QPSK	1@0	see graph	PASS
77	30	20	633334	3500.01	DFT-s-OFDM BPSK	1@0	see graph	---
77	30	20	633334	3500.01	DFT-s-OFDM BPSK	1@0	see graph	PASS
77	30	20	633334	3500.01	DFT-s-OFDM BPSK	1@0	see graph	PASS
77	30	20	633334	3500.01	DFT-s-OFDM QPSK	1@0	see graph	---
77	30	20	633334	3500.01	DFT-s-OFDM QPSK	1@0	see graph	PASS
77	30	20	633334	3500.01	DFT-s-OFDM QPSK	1@0	see graph	PASS
77	30	20	636000	3540.0	DFT-s-OFDM BPSK	1@0	see graph	---
77	30	20	636000	3540.0	DFT-s-OFDM BPSK	1@0	see graph	PASS
77	30	20	636000	3540.0	DFT-s-OFDM BPSK	1@0	see graph	PASS
77	30	20	636000	3540.0	DFT-s-OFDM QPSK	1@0	see graph	---
77	30	20	636000	3540.0	DFT-s-OFDM QPSK	1@0	see graph	PASS
77	30	20	636000	3540.0	DFT-s-OFDM QPSK	1@0	see graph	PASS

N77(20M)_DFT-s-OFDM_BPSK_Edge_1RB_Left_Low_CH

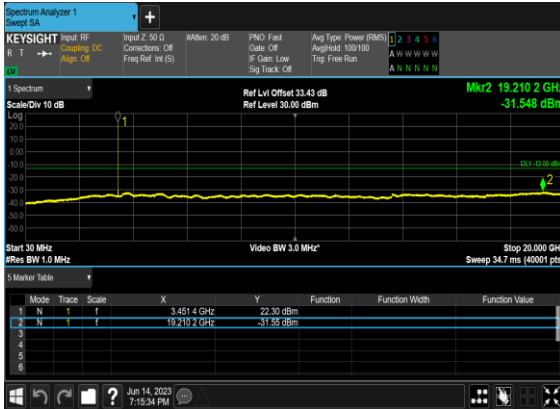

N77(20M)_DFT-s-OFDM_BPSK_Edge_1RB_Left_Low_CH

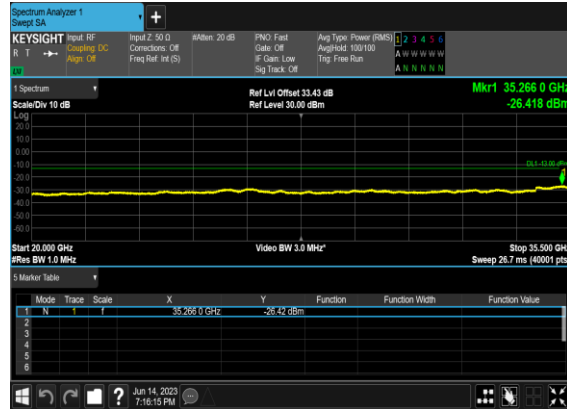

N77(20M)_DFT-s-OFDM_QPSK_Edge_1RB_Left_Low_CH

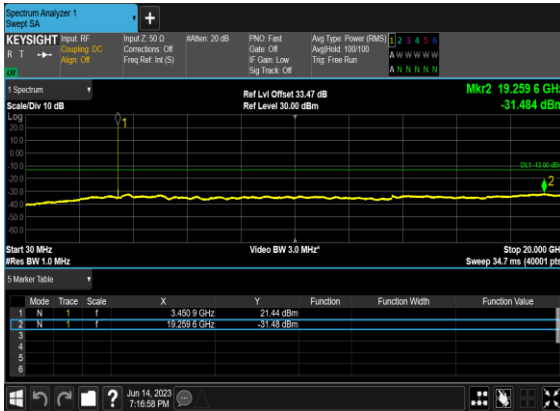

N77(20M)_DFT-s-OFDM_QPSK_Edge_1RB_Left_Low_CH

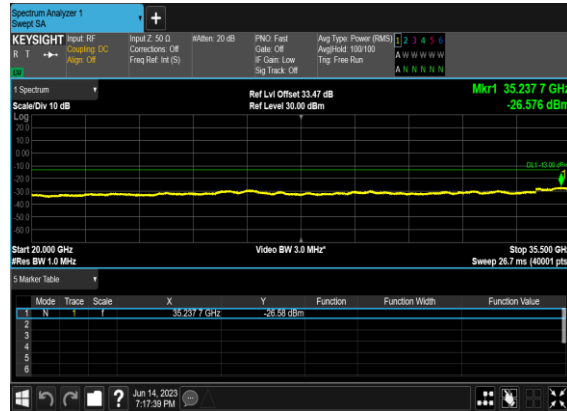

N77(20M)_DFT-s-OFDM_BPSK_Edge_1RB_Left_Mid_CH

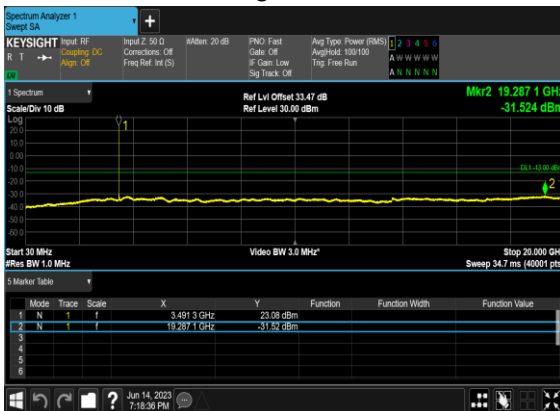

N77(20M)_DFT-s-OFDM_BPSK_Edge_1RB_Left_Mid_CH

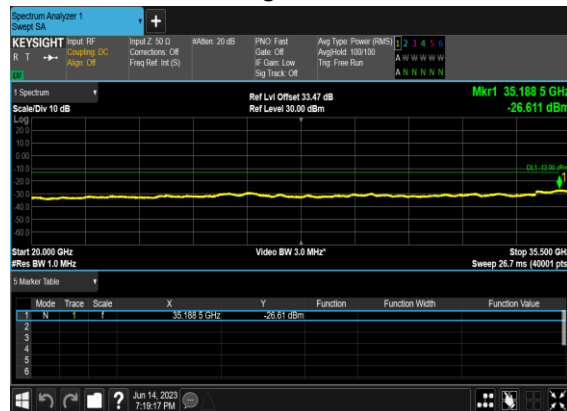

N77(20M)_DFT-s-OFDM_QPSK_Edge_1RB_Left_Mid_CH

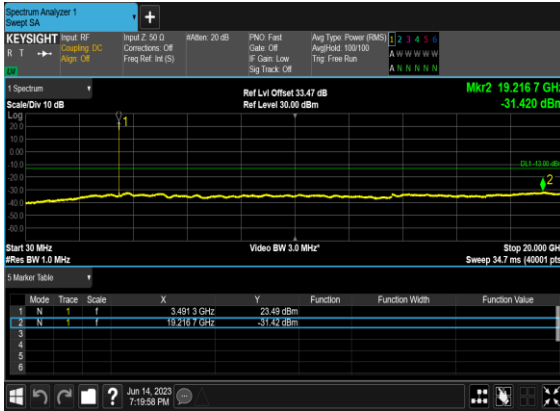

N77(20M)_DFT-s-OFDM_QPSK_Edge_1RB_Left_Mid_CH

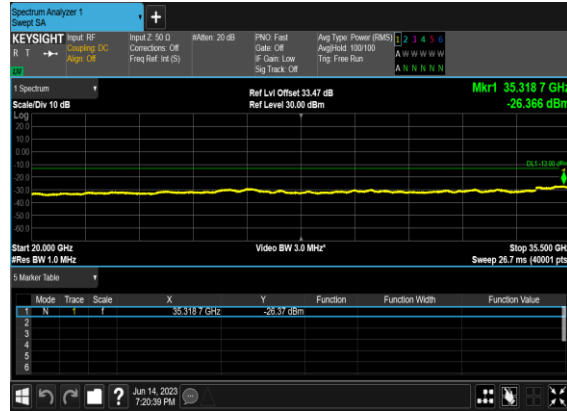

N77(20M)_DFT-s-OFDM_BPSK_Edge_1RB_Left_High_CH

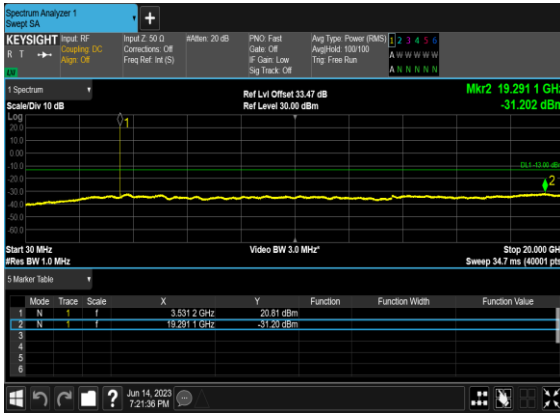

N77(20M)_DFT-s-OFDM_BPSK_Edge_1RB_Left_High_CH

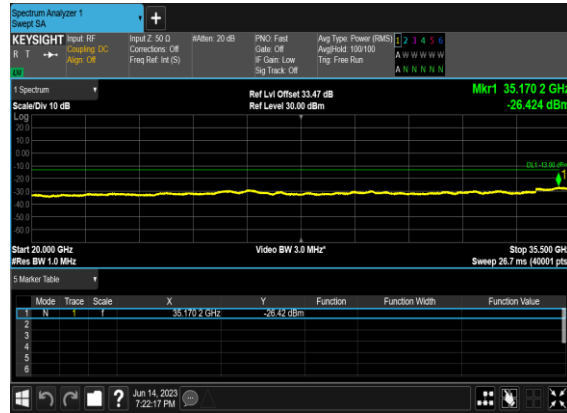

N77(20M)_DFT-s-OFDM_QPSK_Edge_1RB_Left_High_CH

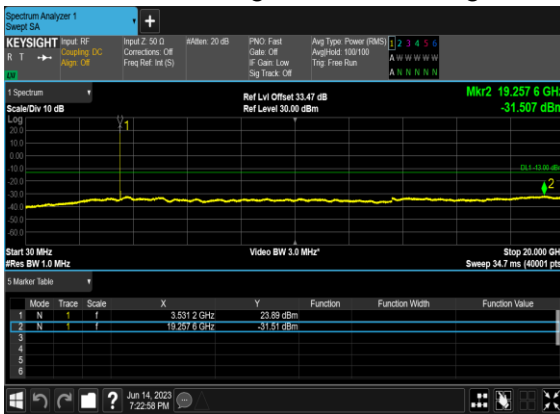

N77(20M)_DFT-s-OFDM_QPSK_Edge_1RB_Left_High_CH

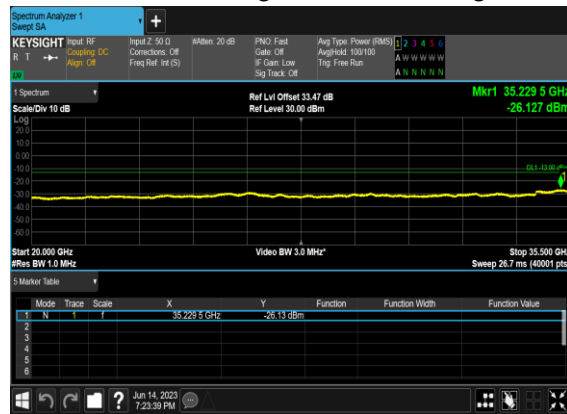

Conducted Band Edge

NR Band	SCS (kHz)	Bandwidth (MHz)	Arfcn	Freq (MHz)	Modulation	RB	Result	Verdict
77	30	20	630668	3460.02	DFT-s-OFDM BPSK	1@0	see graph	PASS
77	30	20	630668	3460.02	DFT-s-OFDM QPSK	1@0	see graph	PASS
77	30	20	630668	3460.02	DFT-s-OFDM BPSK	50@0	see graph	PASS
77	30	20	630668	3460.02	DFT-s-OFDM QPSK	50@0	see graph	PASS
77	30	20	636000	3540.0	DFT-s-OFDM BPSK	1@50	see graph	PASS
77	30	20	636000	3540.0	DFT-s-OFDM QPSK	1@50	see graph	PASS
77	30	20	636000	3540.0	DFT-s-OFDM BPSK	50@0	see graph	PASS
77	30	20	636000	3540.0	DFT-s-OFDM QPSK	50@0	see graph	PASS

N77(20M)_DFT-s-OFDM_BPSK_Edge_1RB_Left_Low_CH

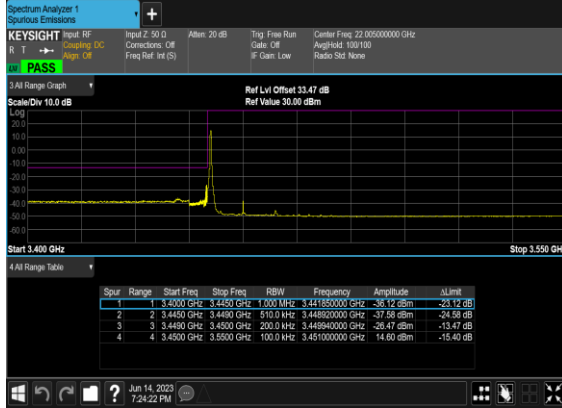

N77(20M)_DFT-s-OFDM_QPSK_Edge_1RB_Left_Low_CH

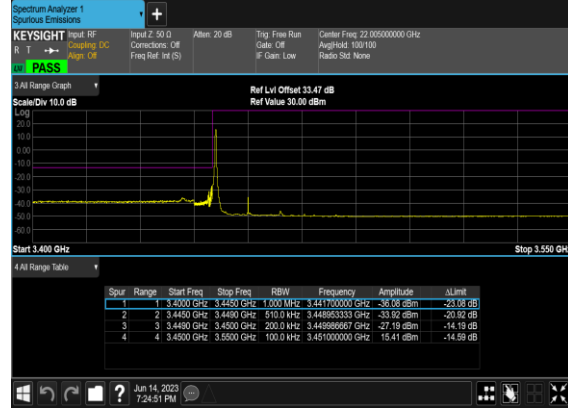

N77(20M)_DFT-s-OFDM_BPSK_Outer_Full_Low_CH

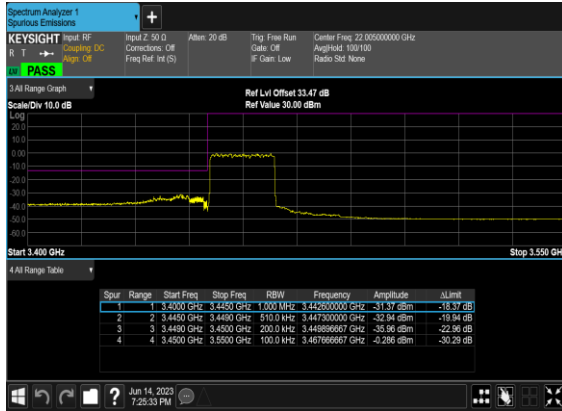

N77(20M)_DFT-s-OFDM_QPSK_Outer_Full_Low_CH

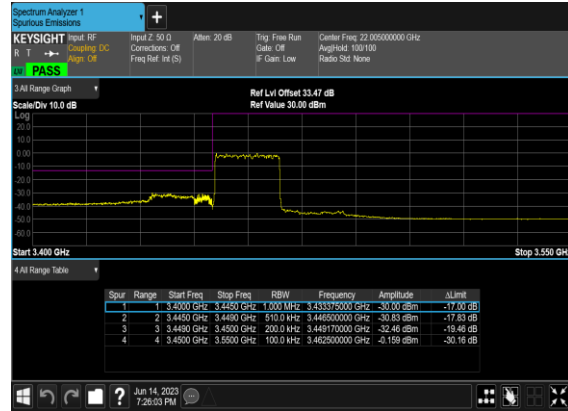

N77(20M)_DFT-s-OFDM_BPSK_Edge_1RB_Right_High_CH

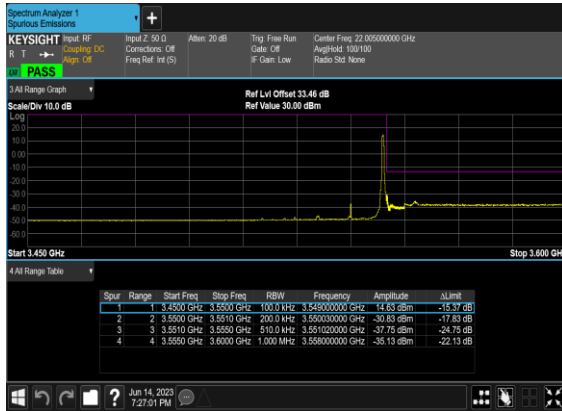

N77(20M)_DFT-s-OFDM_QPSK_Edge_1RB_Right_High_CH

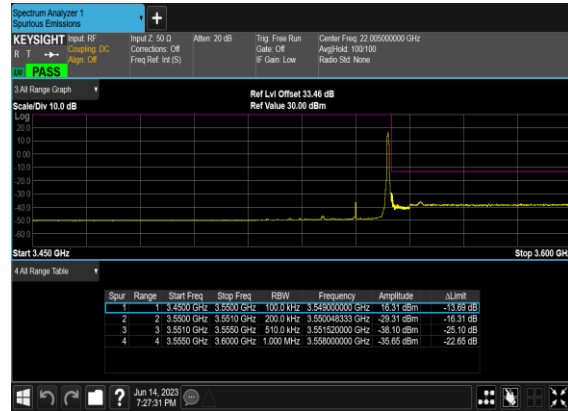

N77(20M)_DFT-s-OFDM_BPSK_Outer_Full_High_CH

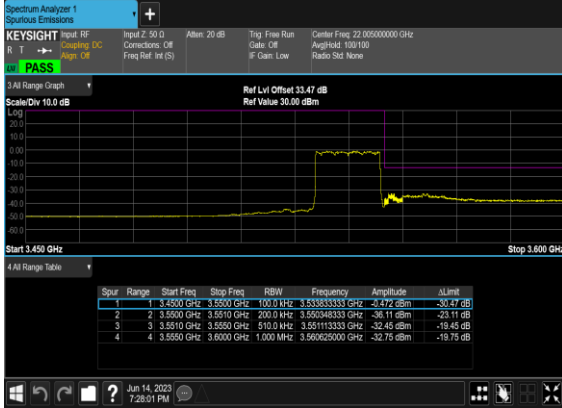

N77(20M)_DFT-s-OFDM_QPSK_Outer_Full_High_CH

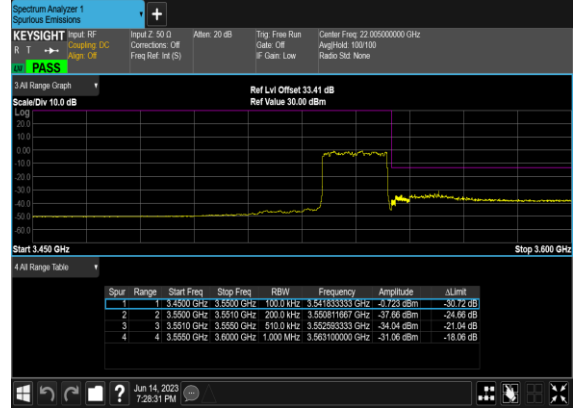

FR1 N78(ANT5)

Transmitter Conducted Output Power And EIRP, (G_T - L_C)=-0.67dBi

NR Band	SCS	Band Width	Arfcn	Freq(MHz)	Modulation	RB	Conducted Power(dBm)	EIRP(dBm)	EIRP(W)
78	30	20	630668	3460.02	DFT-s-OFDM PI/2 BPSK	1@1	24.8	24.13	0.2588
78	30	20	630668	3460.02	DFT-s-OFDM QPSK	1@1	24.8	24.13	0.2588
78	30	20	630668	3460.02	DFT-s-OFDM 16 QAM	1@1	23.59	22.92	0.1959
78	30	20	633334	3500.01	DFT-s-OFDM PI/2 BPSK	1@1	24.8	24.13	0.2588
78	30	20	633334	3500.01	DFT-s-OFDM QPSK	1@1	24.76	24.09	0.2564
78	30	20	633334	3500.01	DFT-s-OFDM 16 QAM	1@1	23.65	22.98	0.1986
78	30	20	636000	3540	DFT-s-OFDM PI/2 BPSK	1@1	24.85	24.18	0.2618
78	30	20	636000	3540	DFT-s-OFDM QPSK	1@1	24.88	24.21	0.2636
78	30	20	636000	3540	DFT-s-OFDM 16 QAM	1@1	23.61	22.94	0.1968
78	30	30	631000	3465	DFT-s-OFDM PI/2 BPSK	1@1	24.72	24.05	0.2541
78	30	30	631000	3465	DFT-s-OFDM QPSK	1@1	24.73	24.06	0.2547
78	30	30	631000	3465	DFT-s-OFDM 16 QAM	1@1	23.42	22.75	0.1884
78	30	30	633334	3500.01	DFT-s-OFDM PI/2 BPSK	1@1	24.59	23.92	0.2466
78	30	30	633334	3500.01	DFT-s-OFDM QPSK	1@1	24.52	23.85	0.2427
78	30	30	633334	3500.01	DFT-s-OFDM 16 QAM	1@1	23.36	22.69	0.1858
78	30	30	635666	3534.99	DFT-s-OFDM PI/2 BPSK	1@1	24.7	24.03	0.2529
78	30	30	635666	3534.99	DFT-s-OFDM QPSK	1@1	24.67	24	0.2512
78	30	30	635666	3534.99	DFT-s-OFDM 16 QAM	1@1	23.51	22.84	0.1923
78	30	40	631334	3470.01	DFT-s-OFDM PI/2 BPSK	1@1	24.69	24.02	0.2523
78	30	40	631334	3470.01	DFT-s-OFDM QPSK	1@1	24.65	23.98	0.2500
78	30	40	631334	3470.01	DFT-s-OFDM 16 QAM	1@1	23.51	22.84	0.1923
78	30	40	633334	3500.01	DFT-s-OFDM PI/2 BPSK	1@1	24.58	23.91	0.2460
78	30	40	633334	3500.01	DFT-s-OFDM QPSK	1@1	24.56	23.89	0.2449
78	30	40	633334	3500.01	DFT-s-OFDM 16 QAM	1@1	23.35	22.68	0.1854
78	30	40	635332	3529.98	DFT-s-OFDM PI/2 BPSK	1@1	24.68	24.01	0.2518
78	30	40	635332	3529.98	DFT-s-OFDM QPSK	1@1	24.68	24.01	0.2518
78	30	40	635332	3529.98	DFT-s-OFDM 16 QAM	1@1	23.55	22.88	0.1941
78	30	50	631668	3475.02	DFT-s-OFDM PI/2 BPSK	1@1	24.74	24.07	0.2553

78	30	50	631668	3475.02	DFT-s-OFDM QPSK	1@1	24.75	24.08	0.2559
78	30	50	631668	3475.02	DFT-s-OFDM 16 QAM	1@1	23.43	22.76	0.1888
78	30	50	633334	3500.01	DFT-s-OFDM PI/2 BPSK	1@1	24.6	23.93	0.2472
78	30	50	633334	3500.01	DFT-s-OFDM QPSK	1@1	24.54	23.87	0.2438
78	30	50	633334	3500.01	DFT-s-OFDM 16 QAM	1@1	23.38	22.71	0.1866
78	30	50	635000	3525	DFT-s-OFDM PI/2 BPSK	1@1	24.75	24.08	0.2559
78	30	50	635000	3525	DFT-s-OFDM QPSK	1@1	24.67	24	0.2512
78	30	50	635000	3525	DFT-s-OFDM 16 QAM	1@1	23.58	22.91	0.1954
78	30	60	632000	3480	DFT-s-OFDM PI/2 BPSK	1@1	24.75	24.08	0.2559
78	30	60	632000	3480	DFT-s-OFDM QPSK	1@1	24.67	24	0.2512
78	30	60	632000	3480	DFT-s-OFDM 16 QAM	1@1	23.44	22.77	0.1892
78	30	60	633334	3500.01	DFT-s-OFDM PI/2 BPSK	1@1	24.53	23.86	0.2432
78	30	60	633334	3500.01	DFT-s-OFDM QPSK	1@1	24.48	23.81	0.2404
78	30	60	633334	3500.01	DFT-s-OFDM 16 QAM	1@1	23.36	22.69	0.1858
78	30	60	634666	3519.99	DFT-s-OFDM PI/2 BPSK	1@1	24.71	24.04	0.2535
78	30	60	634666	3519.99	DFT-s-OFDM QPSK	1@1	24.68	24.01	0.2518
78	30	60	634666	3519.99	DFT-s-OFDM 16 QAM	1@1	23.51	22.84	0.1923
78	30	80	632668	3490.02	DFT-s-OFDM PI/2 BPSK	1@1	24.6	23.93	0.2472
78	30	80	632668	3490.02	DFT-s-OFDM QPSK	1@1	24.71	24.04	0.2535
78	30	80	632668	3490.02	DFT-s-OFDM 16 QAM	1@1	23.34	22.67	0.1849
78	30	80	633334	3500.01	DFT-s-OFDM PI/2 BPSK	1@1	24.5	23.83	0.2415
78	30	80	633334	3500.01	DFT-s-OFDM QPSK	1@1	24.61	23.94	0.2477
78	30	80	633334	3500.01	DFT-s-OFDM 16 QAM	1@1	23.29	22.62	0.1828
78	30	80	634000	3510	DFT-s-OFDM PI/2 BPSK	1@1	24.52	23.85	0.2427
78	30	80	634000	3510	DFT-s-OFDM QPSK	1@1	24.54	23.87	0.2438
78	30	80	634000	3510	DFT-s-OFDM 16 QAM	1@1	23.23	22.56	0.1803
78	30	90	633000	3495	DFT-s-OFDM PI/2 BPSK	1@1	24.54	23.87	0.2438
78	30	90	633000	3495	DFT-s-OFDM QPSK	1@1	24.62	23.95	0.2483
78	30	90	633000	3495	DFT-s-OFDM 16 QAM	1@1	23.36	22.69	0.1858
78	30	90	633334	3500.01	DFT-s-OFDM PI/2 BPSK	1@1	24.53	23.86	0.2432
78	30	90	633334	3500.01	DFT-s-OFDM QPSK	1@1	24.57	23.9	0.2455
78	30	90	633334	3500.01	DFT-s-OFDM 16 QAM	1@1	23.28	22.61	0.1824
78	30	90	633666	3504.99	DFT-s-OFDM PI/2 BPSK	1@1	24.52	23.85	0.2427
78	30	90	633666	3504.99	DFT-s-OFDM QPSK	1@1	24.59	23.92	0.2466

78	30	90	633666	3504.99	DFT-s-OFDM 16 QAM	1@1	23.29	22.62	0.1828
78	30	100	633334	3500.01	DFT-s-OFDM PI/2 BPSK	135@ 67	24.64	23.97	0.2495
78	30	100	633334	3500.01	DFT-s-OFDM PI/2 BPSK	1@1	24.91	24.24	0.2655
78	30	100	633334	3500.01	DFT-s-OFDM PI/2 BPSK	1@27 1	24.34	23.67	0.2328
78	30	100	633334	3500.01	DFT-s-OFDM QPSK	135@ 67	24.69	24.02	0.2523
78	30	100	633334	3500.01	DFT-s-OFDM QPSK	1@1	24.68	24.01	0.2518
78	30	100	633334	3500.01	DFT-s-OFDM QPSK	1@27 1	24.3	23.63	0.2307
78	30	100	633334	3500.01	DFT-s-OFDM 16 QAM	135@ 67	23.71	23.04	0.2014
78	30	100	633334	3500.01	DFT-s-OFDM 16 QAM	1@1	23.53	22.86	0.1932
78	30	100	633334	3500.01	DFT-s-OFDM 16 QAM	1@27 1	23.1	22.43	0.1750
78	30	100	633334	3500.01	DFT-s-OFDM 64 QAM	135@ 67	22.13	21.46	0.1400
78	30	100	633334	3500.01	DFT-s-OFDM 64 QAM	1@1	22.57	21.9	0.1549
78	30	100	633334	3500.01	DFT-s-OFDM 64 QAM	1@27 1	22.09	21.42	0.1387
78	30	100	633334	3500.01	DFT-s-OFDM 256 QAM	135@ 67	20.16	19.49	0.0889
78	30	100	633334	3500.01	DFT-s-OFDM 256 QAM	1@1	20.1	19.43	0.0877
78	30	100	633334	3500.01	DFT-s-OFDM 256 QAM	1@27 1	19.73	19.06	0.0805
78	30	100	633334	3500.01	CP-OFDM QPSK	137@ 68	23.17	22.5	0.1778
78	30	100	633334	3500.01	CP-OFDM QPSK	1@1	23.21	22.54	0.1795
78	30	100	633334	3500.01	CP-OFDM QPSK	1@27 1	22.75	22.08	0.1614

Frequency Stability

NR Band	SCS (kHz)	Bandwidth (MHz)	Arfcn	Freq (MHz)	Modulation	RB	Deviation (ppm)	Verdict	Environment
78	30	20	633334	3500.01	DFT-s-OFDM QPSK	50@0	-0.0026	PASS	NV
78	30	20	633334	3500.01	DFT-s-OFDM QPSK	50@0	0.0013	PASS	LV
78	30	20	633334	3500.01	DFT-s-OFDM QPSK	50@0	0.0021	PASS	HV
78	30	20	633334	3500.01	DFT-s-OFDM QPSK	50@0	0.0025	PASS	-30°C
78	30	20	633334	3500.01	DFT-s-OFDM QPSK	50@0	-0.0019	PASS	-20°C
78	30	20	633334	3500.01	DFT-s-OFDM QPSK	50@0	0.0022	PASS	-10°C
78	30	20	633334	3500.01	DFT-s-OFDM QPSK	50@0	0.0031	PASS	0°C
78	30	20	633334	3500.01	DFT-s-OFDM QPSK	50@0	-0.0016	PASS	10°C
78	30	20	633334	3500.01	DFT-s-OFDM QPSK	50@0	0.0017	PASS	20°C
78	30	20	633334	3500.01	DFT-s-OFDM QPSK	50@0	0.0021	PASS	30°C
78	30	20	633334	3500.01	DFT-s-OFDM QPSK	50@0	0.0049	PASS	40°C
78	30	20	633334	3500.01	DFT-s-OFDM QPSK	50@0	-0.0017	PASS	50°C

Peak to Average Ratio

NR Band	SCS (kHz)	Bandwidth (MHz)	Arfcn	Freq (MHz)	Modulation	RB	Result (dB)	Limit (dB)	Verdict
78	30	20	633334	3500.01	DFT-s-OFDM PI/2 BPSK	50@0	7.11	13	PASS
78	30	20	633334	3500.01	DFT-s-OFDM PI/2 BPSK	1@0	7.47	13	PASS
78	30	20	633334	3500.01	DFT-s-OFDM QPSK	50@0	8.37	13	PASS
78	30	20	633334	3500.01	DFT-s-OFDM QPSK	1@0	7.95	13	PASS

N78(20M)_DFT-s-OFDM_PI_2-BPSK_Outer_Full_Mid_CH



N78(20M)_DFT-s-OFDM_PI_2-BPSK_Edge_1RB_Left_Mid_CH



N78(20M)_DFT-s-OFDM_QPSK_Outer_Full_Mid_CH



N78(20M)_DFT-s-OFDM_QPSK_Edge_1RB_Left_Mid_CH

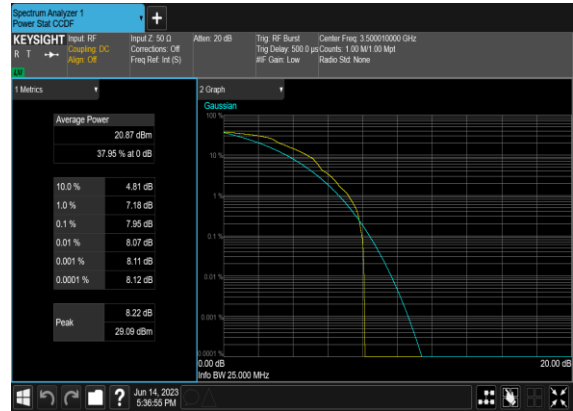

Occupied Bandwidth

NR Band	SCS (kHz)	Bandwidth (MHz)	Arfcn	Freq (MHz)	Modulation	RB	OBW (MHz)	26dB BW (MHz)
78	30	20	633334	3500.01	CP-OFDM QPSK	51@0	18.148	18.84
78	30	20	633334	3500.01	CP-OFDM 16 QAM	51@0	18.163	19.01
78	30	20	633334	3500.01	CP-OFDM 64 QAM	51@0	18.206	18.87
78	30	20	633334	3500.01	CP-OFDM 256 QAM	51@0	18.178	19.0

N78(20M)_CP-OFDM_QPSK_Outer_Full_Mid_CH

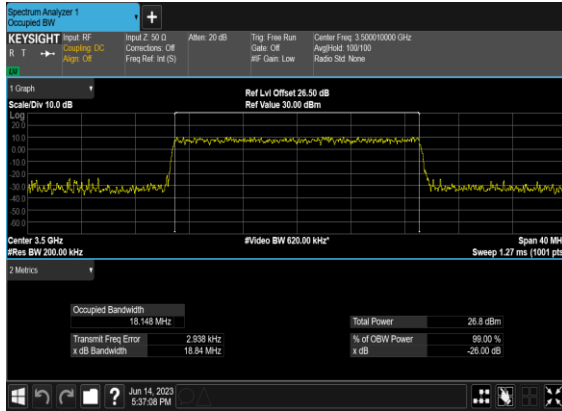

N78(20M)_CP-OFDM_16QAM_Outer_Full_Mid_CH

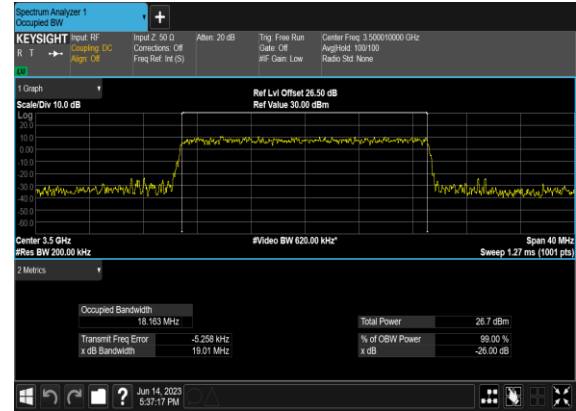

N78(20M)_CP-OFDM_64QAM_Outer_Full_Mid_CH

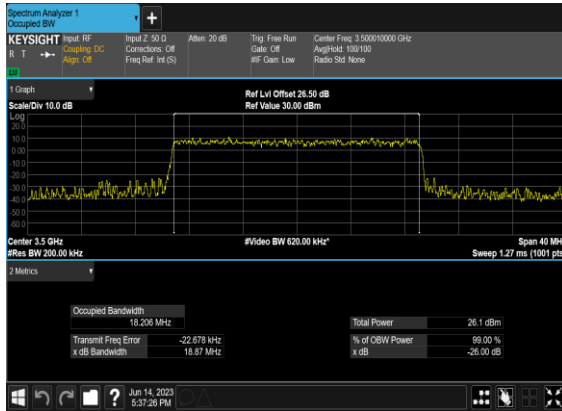

N78(20M)_CP-OFDM_256QAM_Outer_Full_Mid_CH

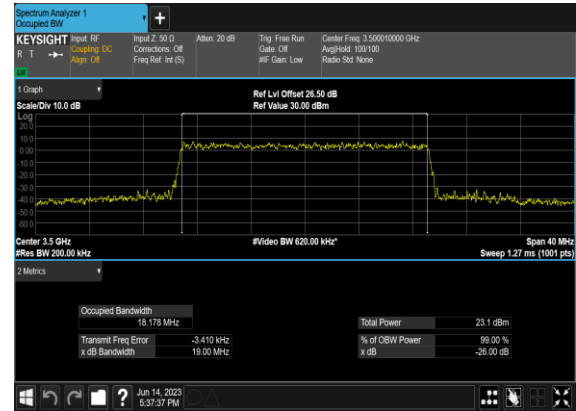

Conducted Spurious Emissions

NR Band	SCS (kHz)	Bandwidth (MHz)	Arfcn	Freq (MHz)	Modulation	RB	Result	Verdict
78	30	20	630668	3460.02	DFT-s-OFDM BPSK	1@0	see graph	---
78	30	20	630668	3460.02	DFT-s-OFDM BPSK	1@0	see graph	PASS
78	30	20	630668	3460.02	DFT-s-OFDM BPSK	1@0	see graph	PASS
78	30	20	630668	3460.02	DFT-s-OFDM QPSK	1@0	see graph	---
78	30	20	630668	3460.02	DFT-s-OFDM QPSK	1@0	see graph	PASS
78	30	20	630668	3460.02	DFT-s-OFDM QPSK	1@0	see graph	PASS
78	30	20	633334	3500.01	DFT-s-OFDM BPSK	1@0	see graph	---
78	30	20	633334	3500.01	DFT-s-OFDM BPSK	1@0	see graph	PASS
78	30	20	633334	3500.01	DFT-s-OFDM BPSK	1@0	see graph	PASS
78	30	20	633334	3500.01	DFT-s-OFDM QPSK	1@0	see graph	---
78	30	20	633334	3500.01	DFT-s-OFDM QPSK	1@0	see graph	PASS
78	30	20	633334	3500.01	DFT-s-OFDM QPSK	1@0	see graph	PASS
78	30	20	636000	3540.0	DFT-s-OFDM BPSK	1@0	see graph	---
78	30	20	636000	3540.0	DFT-s-OFDM BPSK	1@0	see graph	PASS
78	30	20	636000	3540.0	DFT-s-OFDM BPSK	1@0	see graph	PASS
78	30	20	636000	3540.0	DFT-s-OFDM QPSK	1@0	see graph	---
78	30	20	636000	3540.0	DFT-s-OFDM QPSK	1@0	see graph	PASS
78	30	20	636000	3540.0	DFT-s-OFDM QPSK	1@0	see graph	PASS

N78(20M)_DFT-s-OFDM_BPSK_Edge_1RB_Left_Low_CH

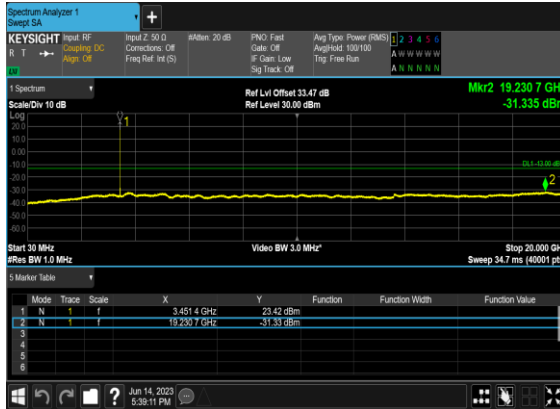

N78(20M)_DFT-s-OFDM_BPSK_Edge_1RB_Left_Low_CH

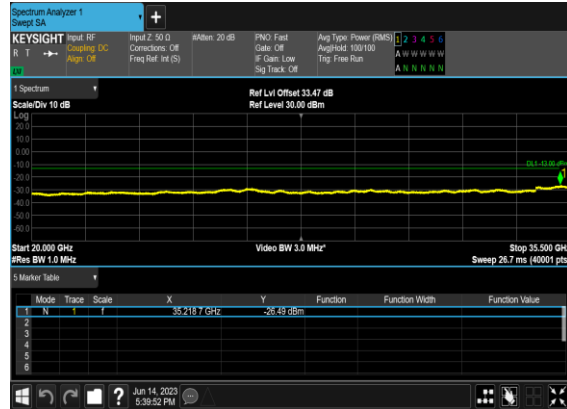

N78(20M)_DFT-s-OFDM_QPSK_Edge_1RB_Left_Low_CH

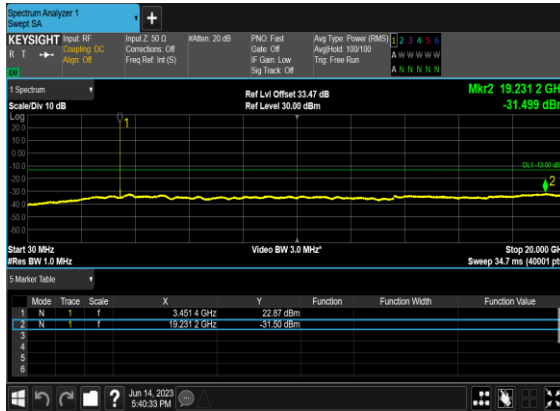

N78(20M)_DFT-s-OFDM_QPSK_Edge_1RB_Left_Low_CH

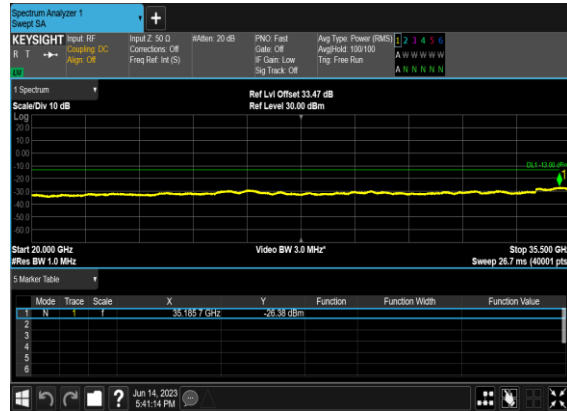

N78(20M)_DFT-s-OFDM_BPSK_Edge_1RB_Left_Mid_CH

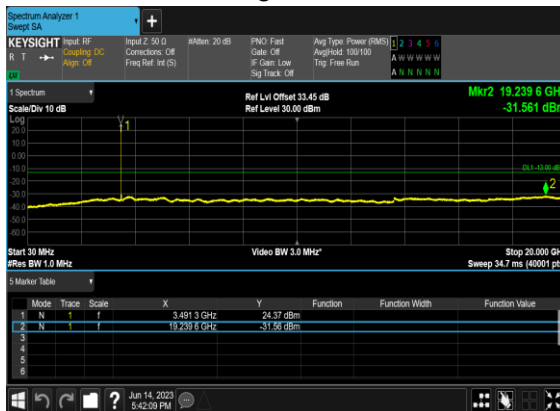

N78(20M)_DFT-s-OFDM_BPSK_Edge_1RB_Left_Mid_CH

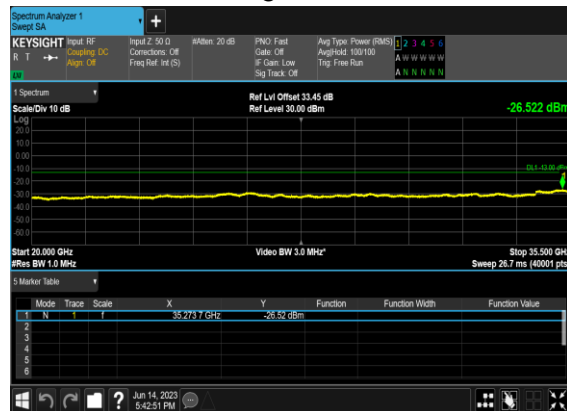

N78(20M)_DFT-s-OFDM_QPSK_Edge_1RB_Left_Mid_CH

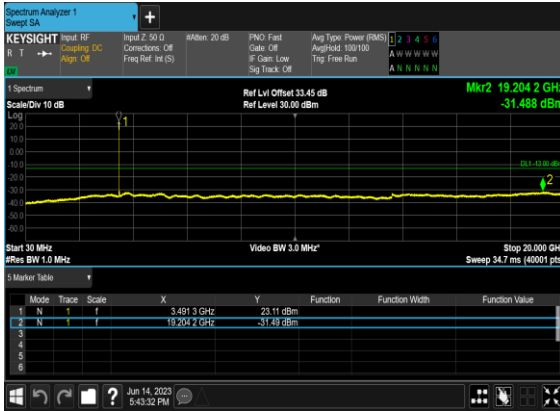

N78(20M)_DFT-s-OFDM_QPSK_Edge_1RB_Left_Mid_CH

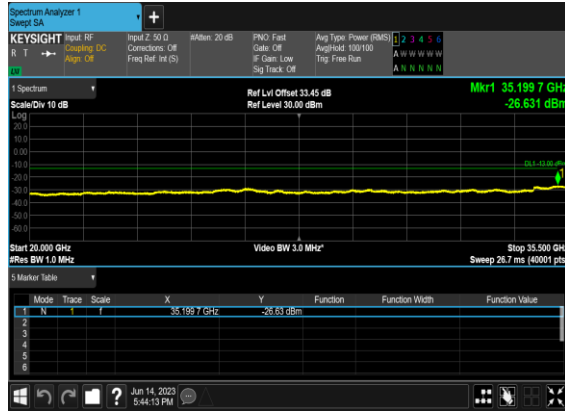

N78(20M)_DFT-s-OFDM_BPSK_Edge_1RB_Left_High_CH

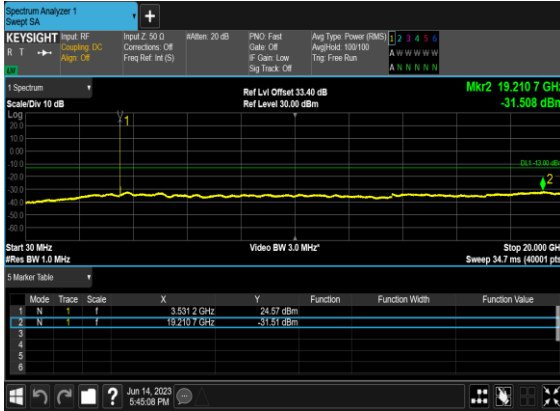

N78(20M)_DFT-s-OFDM_BPSK_Edge_1RB_Left_High_CH

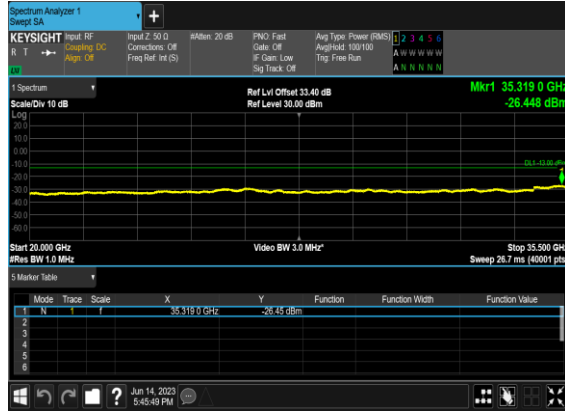

N78(20M)_DFT-s-OFDM_QPSK_Edge_1RB_Left_High_CH

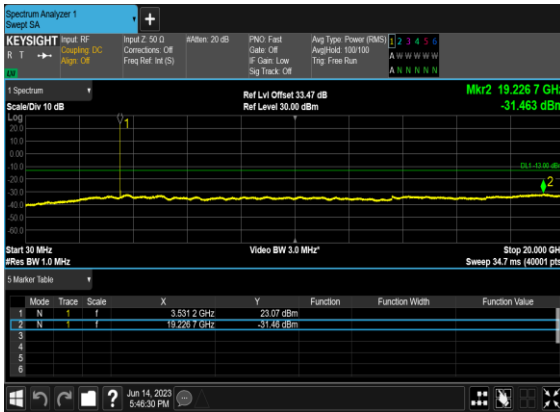

N78(20M)_DFT-s-OFDM_QPSK_Edge_1RB_Left_High_CH

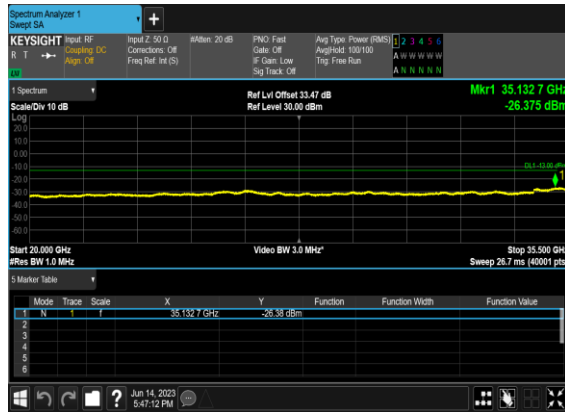

Conducted Band Edge

NR Band	SCS (kHz)	Bandwidth (MHz)	Arfcn	Freq (MHz)	Modulation	RB	Result	Verdict
78	30	20	630668	3460.02	DFT-s-OFDM BPSK	1@0	see graph	PASS
78	30	20	630668	3460.02	DFT-s-OFDM QPSK	1@0	see graph	PASS
78	30	20	630668	3460.02	DFT-s-OFDM BPSK	50@0	see graph	PASS
78	30	20	630668	3460.02	DFT-s-OFDM QPSK	50@0	see graph	PASS
78	30	20	636000	3540.0	DFT-s-OFDM BPSK	1@50	see graph	PASS
78	30	20	636000	3540.0	DFT-s-OFDM QPSK	1@50	see graph	PASS
78	30	20	636000	3540.0	DFT-s-OFDM BPSK	50@0	see graph	PASS
78	30	20	636000	3540.0	DFT-s-OFDM QPSK	50@0	see graph	PASS

N78(20M)_DFT-s- OFDM_BPSK_Edge_1RB_Left_Low_CH

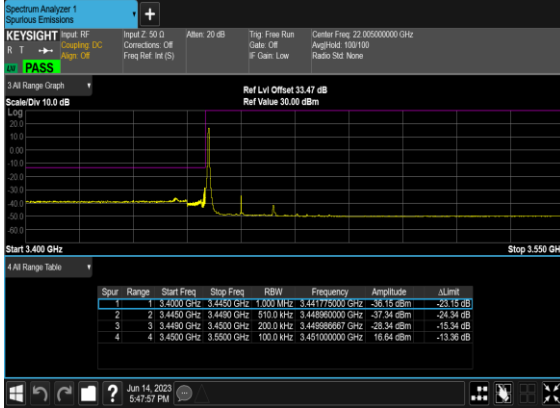

N78(20M)_DFT-s- OFDM_QPSK_Edge_1RB_Left_Low_CH

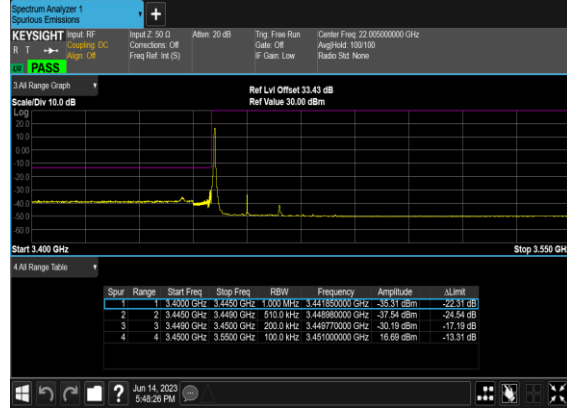

N78(20M)_DFT-s- OFDM_BPSK_Outer_Full_Low_CH

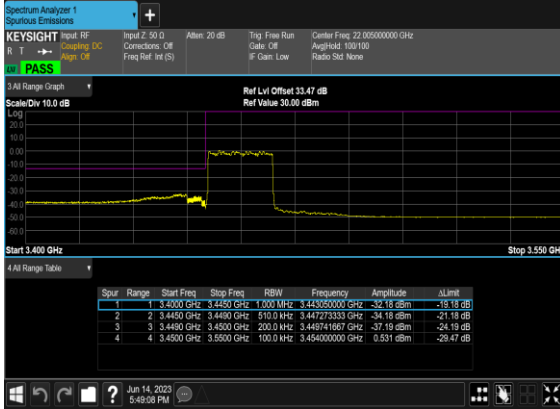

N78(20M)_DFT-s- OFDM_QPSK_Outer_Full_Low_CH

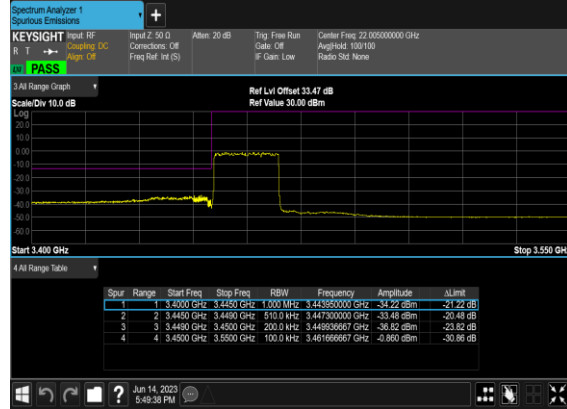

N78(20M)_DFT-s- OFDM_BPSK_Edge_1RB_Right_High_CH

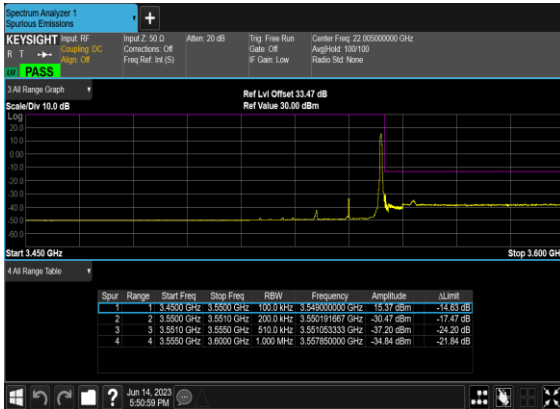

N78(20M)_DFT-s- OFDM_QPSK_Edge_1RB_Right_High_CH

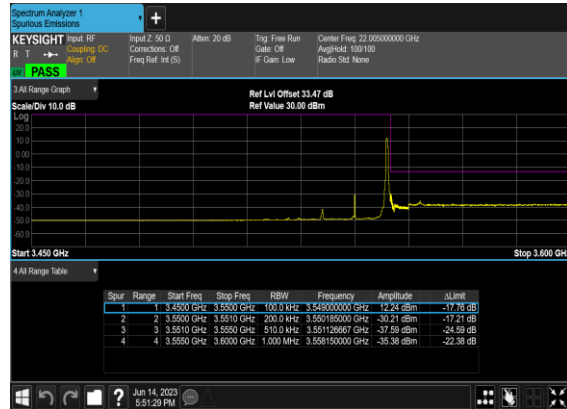

N78(20M)_DFT-s-OFDM_BPSK_Outer_Full_High_CH

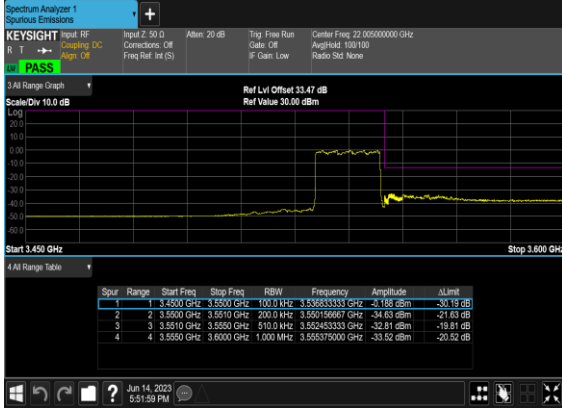

N78(20M)_DFT-s-OFDM_QPSK_Outer_Full_High_CH

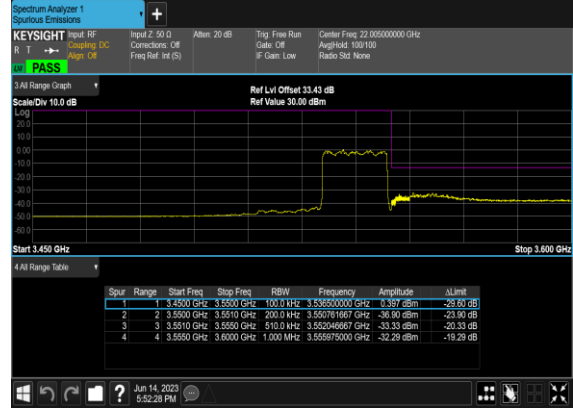



Appendix B. Test Results of Radiated Test

Radiated Spurious Emission

Test Engineer :	Moon Liu	Temperature :	23~25°C
		Relative Humidity :	41~42%

RSE pre-scanned harmonic for different antennas, choose the worst antenna perform final test and record in the report.

n77 SA / NR 100MHz / QPSK / ANT5								
Channel	Frequency (MHz)	EIRP (dBm)	Limit (dBm)	Over Limit (dB)	S.G. Power (dBm)	TX Cable loss (dB)	TX Antenna Gain (dBi)	Polarization (H/V)
Middle	6912	-62.74	-13	-49.74	-72.95	3.03	13.24	H
	10368	-58.49	-13	-45.49	-67.94	3.56	13.01	H
	13824	-58.89	-13	-45.89	-68.41	3.92	13.44	H
	6912	-62.59	-13	-49.59	-72.80	3.03	13.24	V
	10368	-58.64	-13	-45.64	-68.09	3.56	13.01	V
	13824	-58.92	-13	-45.92	-68.44	3.92	13.44	V

Remark: Spurious emissions within 30-1000MHz were found more than 20dB below limit line.