



FCC RF Test Report

APPLICANT : Xiaomi Communications Co., Ltd.
EQUIPMENT : Mobile Phone
BRAND NAME : Xiaomi
MODEL NAME : A301XM
FCC ID : 2AFZZND5R
STANDARD : 47 CFR Part 2, 27 Subpart O (3700-3980MHz)
CLASSIFICATION : PCS Licensed Transmitter Held to Ear (PCE)
TEST DATE(S) : Jun. 14, 2023 ~ Jul. 19, 2023

We, Sporton International Inc. (KunShan), would like to declare that the tested sample has been evaluated in accordance with the procedures given in ANSI C63.26-2015 and shown compliance with the applicable technical standards.

The test results in this report apply exclusively to the tested model / sample. Without written approval of Sporton International Inc. (KunShan), the test report shall not be reproduced except in full.

Jason Jia

Approved by: Jason Jia



Sporton International Inc. (Kunshan)

**No. 1098, Pengxi North Road, Kunshan Economic Development Zone Jiangsu Province 215300
People's Republic of China**



TABLE OF CONTENTS

REVISION HISTORY...3
SUMMARY OF TEST RESULT...4
1 GENERAL DESCRIPTION...5
1.1 Applicant...5
1.2 Manufacturer...5
1.3 Product Feature of Equipment Under Test...5
1.4 Product Specification of Equipment Under Test...5
1.5 Modification of EUT...6
1.6 Maximum EIRP and Emission Designator...6
1.7 Testing Location...7
1.8 Test Software...7
1.9 Applicable Standards...7
2 TEST CONFIGURATION OF EQUIPMENT UNDER TEST...8
2.1 Test Mode...8
2.2 Connection Diagram of Test System...9
2.3 Support Unit used in test configuration and system...9
2.4 Measurement Results Explanation Example...9
2.5 Frequency List of Low/Middle/High Channels...10
3 CONDUCTED TEST ITEMS...11
3.1 Measuring Instruments...11
3.2 Test Setup...11
3.3 Test Result of Conducted Test...11
3.4 Conducted Output Power and EIRP...12
3.5 Peak-to-Average Ratio...13
3.6 Occupied Bandwidth...14
3.7 Conducted Band Edge...15
3.8 Conducted Spurious Emission...16
3.9 Frequency Stability...17
4 RADIATED TEST ITEMS...18
4.1 Measuring Instruments...18
4.2 Test Setup...18
4.3 Test Result of Radiated Test...19
4.4 Radiated Spurious Emission...20
5 LIST OF MEASURING EQUIPMENT...21
6 MEASUREMENT UNCERTAINTY...22
APPENDIX A. TEST RESULTS OF CONDUCTED TEST
APPENDIX B. TEST RESULTS OF RADIATED TEST
APPENDIX C. TEST SETUP PHOTOGRAPHS



SUMMARY OF TEST RESULT

Report Section	FCC Rule	Description	Limit	Result	Remark
3.4	§2.1046	Conducted Output Power	Reporting Only	PASS	-
	§27.50(j)(3)	Equivalent Isotropic Radiated Power (5G NR n77, n78)	EIRP < 1Watt		
3.5	§27.50(j)(4)	Peak-to-Average Ratio	<13 dB	PASS	-
3.6	§2.1049	Occupied Bandwidth	Reporting Only	PASS	-
3.7	§2.1051 §27.53(l)(2)	Conducted Band Edge Measurement (5G NR n77, n78)	< 43+10log10(P[Watts])	PASS	-
3.8	§2.1051 §27.53(l)(2)	Conducted Spurious Emission (5G NR n77, n78)	< 43+10log10(P[Watts])	PASS	-
3.9	§27.54	Frequency Stability Temperature & Voltage	Within Authorized Band	PASS	-
4.4	§2.1053 §27.53(l)(2)	Radiated Spurious Emission (5G NR n77, n78)	< 43+10log ₁₀ (P[Watts])	PASS	Under limit 42.91 dB at 11388.00 MHz

Note: only 20M BW and Power/EIRP/RSE are assessed in this report, all the other test results are leveraged from original report FG351205J which is issued separately.

Conformity Assessment Condition:
1. The test results (PASS/FAIL) with all measurement uncertainty excluded are presented against the regulation limits or in accordance with the requirements stipulated by the applicant/manufacturer who shall bear all the risks of non-compliance that may potentially occur if measurement uncertainty is taken into account.
2. The measurement uncertainty please refer to each test result in the section "Measurement Uncertainty"
Disclaimer:
The product specifications of the EUT presented in the test report that may affect the test assessments are declared by the manufacturer who shall take full responsibility for the authenticity.



1 General Description

1.1 Applicant

Xiaomi Communications Co., Ltd.

#019, 9th Floor, Building 6, 33 Xi'erqi Middle Road, Haidian District, Beijing, China, 100085

1.2 Manufacturer

Xiaomi Communications Co., Ltd.

#019, 9th Floor, Building 6, 33 Xi'erqi Middle Road, Haidian District, Beijing, China, 100085

1.3 Product Feature of Equipment Under Test

Product Feature	
Equipment	Mobile Phone
Brand Name	Xiaomi
Model Name	A301XM
FCC ID	2AFZZND5R
IMEI Code	Conducted: 869272060003543/86927060003550 Radiation : 869272060005449 / 869272060005456
HW Version	P2.0
SW Version	MIUI 14
EUT Stage	Identical Prototype

1.4 Product Specification of Equipment Under Test

Standards-related Product Specification	
Tx/Rx Frequency	5G NR n77: 3700 MHz ~ 3980 MHz 5G NR n78: 3700 MHz ~ 3800 MHz
SCS	30kHz
Bandwidth	n77/n78(30kHz): 20 / 30 / 40 / 50 / 60 / 80 / 90 / 100MHz
Antenna Gain	<Ant. 1> 5G NR n77: -7.00 dBi 5G NR n78: -7.00 dBi <Ant. 5> 5G NR n77: -0.26 dBi 5G NR n78: -0.67 dBi <Ant. 6> 5G NR n77: -1.00 dBi 5G NR n78: -1.00 dBi <Ant. 7> 5G NR n77: -6.10 dBi 5G NR n78: -6.10 dBi
Type of Modulation	CP-OFDM: QPSK / 16QAM / 64QAM / 256QAM DFT-s-OFDM: PI/2 BPSK / QPSK / 16QAM / 64QAM / 256QAM

Remark:

- The maximum EIRP is calculated from max output power and max antenna gain, only the maximum EIRP of Ant.5 for 5G NR n77/n78 are shown in the report.



- 2. 5G NR n77/n78 supports SA mode only.

1.5 Modification of EUT

No modifications are made to the EUT during all test items.

1.6 Maximum EIRP and Emission Designator

5G NR n77		PI/2 BPSK / QPSK		16QAM / 64QAM / 256QAM	
BW (MHz)	Frequency Range (MHz)	Maximum EIRP(W)	Emission Designator (99%OBW)	Maximum EIRP(W)	Emission Designator (99%OBW)
20	3710.01 ~ 3969.99	0.2780	18M2G7D	0.2065	18M2W7D
30	3715.02 ~ 3964.98	0.2704	-	0.2046	-
40	3720.00 ~ 3960.00	0.2716	-	0.2032	-
50	3725.01 ~ 3954.99	0.2692	-	0.1982	-
60	3730.02 ~ 3949.98	0.2655	-	0.1950	-
80	3740.01 ~ 3939.99	0.2667	-	0.1910	-
90	3745.02 ~ 3934.98	0.2649	-	0.1919	-
100	3750.00 ~ 3930.00	0.2858	-	0.2223	-

5G NR n78		PI/2 BPSK / QPSK		16QAM / 64QAM / 256QAM	
BW (MHz)	Frequency Range (MHz)	Maximum EIRP(W)	Emission Designator (99%OBW)	Maximum EIRP(W)	Emission Designator (99%OBW)
20	3710.01 ~ 3789.99	0.2438	18M2G7D	0.1849	18M2W7D
30	3715.02 ~ 3784.98	0.2432	-	0.1803	-
40	3720.00 ~ 3780.00	0.2449	-	0.1820	-
50	3725.01 ~ 3774.99	0.2382	-	0.1774	-
60	3730.02 ~ 3769.98	0.2360	-	0.1786	-
80	3740.01 ~ 3759.99	0.2360	-	0.1718	-
90	3745.02 ~ 3754.98	0.2339	-	0.1690	-
100	3750.00 ~ 3750.00	0.2472	-	0.1941	-

Note: only 20M BW and Power/EIRP/RSE are assessed in this report, all the other test results are leveraged from original report FG351205J which is issued separately.



1.7 Testing Location

Sporton International Inc. (Kunshan) is accredited to ISO/IEC 17025:2017 by American Association for Laboratory Accreditation with Certificate Number 5145.02.

Test Firm	Sporton International Inc. (Kunshan)		
Test Site Location	No. 1098, Pengxi North Road, Kunshan Economic Development Zone Jiangsu Province 215300 People's Republic of China TEL : +86-512-57900158		
Test Site No.	Sporton Site No.	FCC Designation No.	FCC Test Firm Registration No.
	TH01-KS 03CH04-KS	CN1257	314309

1.8 Test Software

Item	Site	Manufacturer	Name	Version
1.	03CH04-KS	AUDIX	E3	6.2009-8-24al

1.9 Applicable Standards

According to the specifications of the manufacturer, the EUT must comply with the requirements of the following standards:

- ♦ 47 CFR Part 2, 270
- ♦ ANSI C63.26-2015
- ♦ FCC KDB 971168 D01 Power Meas License Digital Systems v03r01
- ♦ FCC KDB 412172 D01 Determining ERP and EIRP v01r01

Remark:

All test items were verified and recorded according to the standards and without any deviation during the test.



2 Test Configuration of Equipment Under Test

2.1 Test Mode

Antenna port conducted and radiated test items are performed according to KDB 971168 D01 Power Meas License Digital Systems v03r01 with maximum output power.

For radiated measurement, pre-scanned in three orthogonal panels, X, Y, Z. The worst cases (X plane) were recorded in this report.

The device is investigated from 30MHz to 10 times of fundamental signal for radiated spurious emission test under different RB size/offset and modulations in exploratory test. Subsequently, only the worst case emissions are reported.

Orthogonal Planes of EUT	X Plane	Y Plane	Z Plane
			

Test Items	5G NR	Bandwidth (MHz)											Modulation					RB #			Test Channel				
		10	15	20	25	30	40	50	60	70	80/90	100	PI/2 BPSK	QPSK	16 QAM	64 QAM	256 QAM	1	Part	Full	L	M	H		
Max. Output Power	n77	-	-	v	-	v	v	v	v	-	v	v	v	v	v	v	v	v		v	v	v	v		
	n78	-	-	v	-	v	v	v	v	-	v	v	v	v	v	v	v	v		v	v	v	v		
Peak-to-Average Ratio	n77	-	-	v	-					-			v	v				v		v		v			
	n78	-	-	v	-					-			v	v				v		v		v			
26dB and 99% Bandwidth	n77	-	-	v	-					-				v	v	v	v			v		v			
	n78	-	-	v	-					-				v	v	v	v			v		v			
Conducted Band Edge	n77	-	-	v	-					-			v	v				v		v	v	v	v		
	n78	-	-	v	-					-			v	v				v		v	v	v	v		
Conducted Spurious Emission	n77	-	-	v	-					-			v	v				v			v	v	v		
	n78	-	-	v	-					-			v	v				v			v	v	v		
Frequency Stability	n77	-	-	v	-					-				v						v		v			
	n78	-	-	v	-					-				v						v		v			
E.I.R.P	n77	-	-	v	-	v	v	v	v	-	v	v	v	v	v	v	v	v		v	v	v	v		
	n78	-	-	v	-	v	v	v	v	-	v	v	v	v	v	v	v	v		v	v	v	v		
Radiated Spurious Emission	n77	Worst Case																						v	
	n78	Worst Case																						v	
Note	1. The mark "v" means that this configuration is chosen for testing 2. The mark "-" means that this bandwidth is not supported. 3. The device is investigated from 30MHz to 10 times of fundamental signal for radiated spurious emission test under different RB size/offset and modulations in exploratory test. Subsequently, only the worst case emissions are reported. 4. Frequency Stability : Normal Voltage = 3.88V; Low Voltage =3.60V; High Voltage =4.47V.																								

2.2 Connection Diagram of Test System

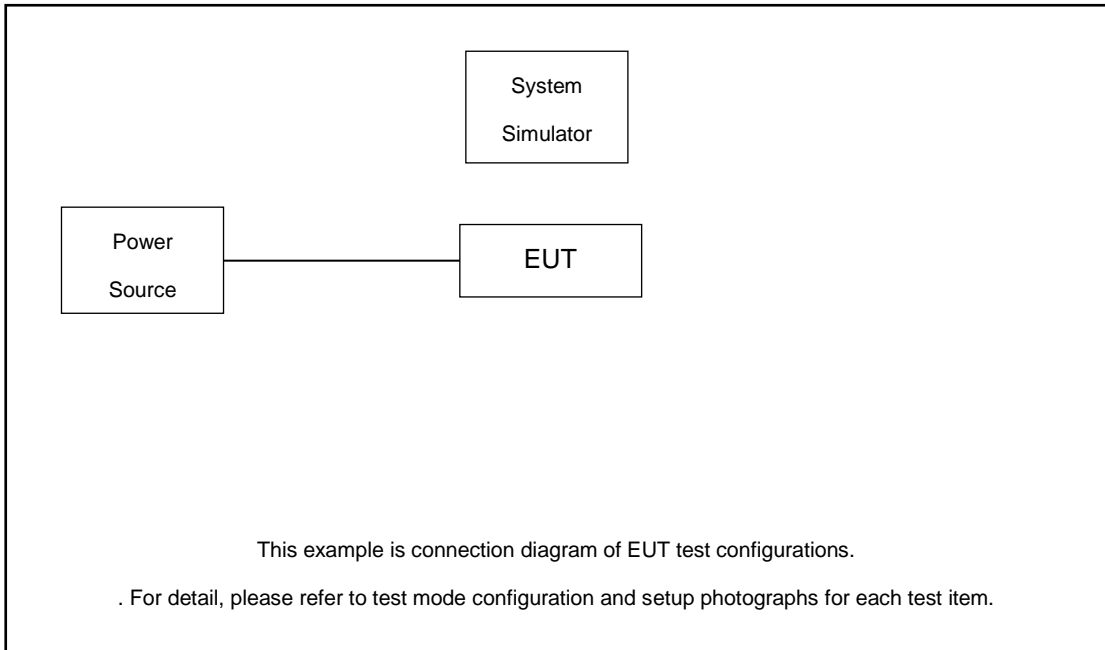

2.3 Support Unit used in test configuration and system

Item	Equipment	Trade Name	Model No.	FCC ID	Data Cable	Power Cord
1.	DC Power Supply	GW	GPS-3030D	N/A	N/A	Unshielded, 1.8 m
2.	NR Base Station	Anritsu	MT8000A	N/A	N/A	Unshielded, 1.8 m

2.4 Measurement Results Explanation Example

For all conducted test items:

The offset level is set in the spectrum analyzer to compensate the RF cable loss and attenuator factor between EUT conducted output port and spectrum analyzer. With the offset compensation, the spectrum analyzer reading level is exactly the EUT RF output level.

The spectrum analyzer offset is derived from RF cable loss and attenuator factor.

Offset = RF cable loss + attenuator factor.

Following shows an offset computation example with cable loss 3.49 dB and 10dB attenuator.

Example :

$$\begin{aligned}
 \text{Offset(dB)} &= \text{RF cable loss(dB)} + \text{attenuator factor(dB)}. \\
 &= 3.49 + 10 = 13.49 \text{ (dB)}
 \end{aligned}$$



2.5 Frequency List of Low/Middle/High Channels

5G n77 (30kHz) Channel and Frequency List				
BW [MHz]	Channel/Frequency(MHz)	Lowest	Middle	Highest
100	Channel	650000	656000	662000
	Frequency	3750	3840	3930
90	Channel	649668	656000	662332
	Frequency	3745.02	3840	3934.98
80	Channel	649334	656000	662666
	Frequency	3740.01	3840	3939.99
60	Channel	648668	656000	663332
	Frequency	3730.02	3840	3949.98
50	Channel	648334	656000	663666
	Frequency	3725.01	3840	3954.99
40	Channel	648000	656000	664000
	Frequency	3720	3840	3960
30	Channel	647668	656000	664332
	Frequency	3715.02	3840	3964.98
20	Channel	647334	656000	664666
	Frequency	3710.01	3840	3969.99

5G n78(30kHz) Channel and Frequency List				
BW [MHz]	Channel/Frequency(MHz)	Lowest	Middle	Highest
100	Channel	650000		
	Frequency	3750		
90	Channel	649668	650000	650332
	Frequency	3745.02	3750	3754.98
80	Channel	649334	650000	650666
	Frequency	3740.01	3750	3759.99
60	Channel	648668	650000	651332
	Frequency	3730.02	3750	3769.98
50	Channel	648334	650000	651666
	Frequency	3725.01	3750	3774.99
40	Channel	648000	650000	652000
	Frequency	3720	3750	3780
30	Channel	647668	650000	652332
	Frequency	3715.02	3750	3784.98
20	Channel	647334	650000	652666
	Frequency	3710.01	3750	3789.99

3 Conducted Test Items

3.1 Measuring Instruments

See list of measuring instruments of this test report.

3.2 Test Setup

3.2.1 Conducted Output Power



3.2.2 Peak-to-Average Ratio, Occupied Bandwidth, Conducted Band-Edge and Conducted Spurious Emission

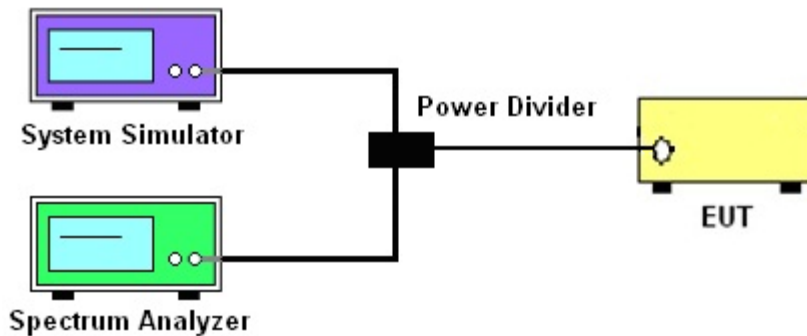

3.2.3 Frequency Stability

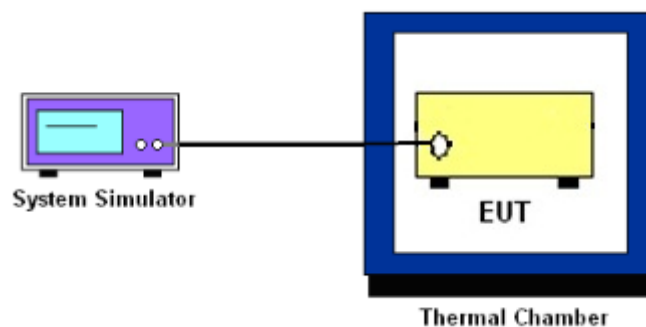

3.3 Test Result of Conducted Test

Please refer to Appendix A.



3.4 Conducted Output Power and EIRP

3.4.1 Description of the Conducted Output Power Measurement and EIRP Measurement

A system simulator was used to establish communication with the EUT. Its parameters were set to force the EUT transmitting at maximum output power. The measured power in the radio frequency on the transmitter output terminals shall be reported.

The EIRP of mobile transmitters must not exceed 1 Watts for 5G NR n77, n78.

According to KDB 412172 D01 Power Approach,

$EIRP = P_T + G_T - L_C$, $ERP = EIRP - 2.15$, where

P_T = transmitter output power in dBm

G_T = gain of the transmitting antenna in dBi

L_C = signal attenuation in the connecting cable between the transmitter and antenna in dB

3.4.2 Test Procedures

1. The testing follows ANSI C63.26 Section 5.2
2. The transmitter output port was connected to the system simulator.
3. Set EUT at maximum power through the system simulator.
4. Select lowest, middle, and highest channels for each band and different modulation.
5. Measure and record the power level from the system simulator.



3.5 Peak-to-Average Ratio

3.5.1 Description of the PAR Measurement

Power Complementary Cumulative Distribution Function (CCDF) curves provide a means for characterizing the power peaks of a digitally modulated signal on a statistical basis. A CCDF curve depicts the probability of the peak signal amplitude exceeding the average power level. Most contemporary measurement instrumentation include the capability to produce CCDF curves for an input signal provided that the instrument's resolution bandwidth can be set wide enough to accommodate the entire input signal bandwidth. In measuring transmissions in this band using an average power technique, the peak-to-average ratio (PAR) of the transmission may not exceed 13 dB.

3.5.2 Test Procedures

1. The testing follows ANSI C63.26 Section 5.2.3.4 (CCDF).
2. The EUT was connected to spectrum and system simulator via a power divider.
3. Set the CCDF (Complementary Cumulative Distribution Function) option in spectrum analyzer.
4. The highest RF powers were measured and recorded the maximum PAPR level associated with a probability of 0.1 %.
5. Record the deviation as Peak to Average Ratio.



3.6 Occupied Bandwidth

3.6.1 Description of Occupied Bandwidth Measurement

The occupied bandwidth is the width of a frequency band such that, below the lower and above the upper frequency limits, the mean powers emitted are each equal to a specified percentage 0.5% of the total mean transmitted power.

The 26 dB emission bandwidth is defined as the frequency range between two points, one above and one below the carrier frequency, at which the spectral density of the emission is attenuated 26 dB below the maximum in-band spectral density of the modulated signal. Spectral density (power per unit bandwidth) is to be measured with a detector of resolution bandwidth equal to approximately 1.0% of the emission bandwidth.

3.6.2 Test Procedures

1. The testing follows ANSI C63.26 Section 5.4
2. The EUT was connected to spectrum analyzer and system simulator via a power divider.
3. The spectrum analyzer center frequency is set to the nominal EUT channel center frequency. The span range for the spectrum analyzer shall be between two and five times the anticipated OBW.
4. The nominal resolution bandwidth (RBW) shall be in the range of 1 to 5 % of the anticipated OBW, and the VBW shall be at least 3 times the RBW.
5. Set the detection mode to peak, and the trace mode to max hold.
6. Determine the reference value: Set the EUT to transmit a modulated signal. Allow the trace to stabilize. Set the spectrum analyzer marker to the highest level of the displayed trace.
(this is the reference value)
7. Determine the “-26 dB down amplitude” as equal to (Reference Value – X).
8. Place two markers, one at the lowest and the other at the highest frequency of the envelope of the spectral display such that each marker is at or slightly below the “-X dB down amplitude” determined in step 6. If a marker is below this “-X dB down amplitude” value it shall be placed as close as possible to this value. The OBW is the positive frequency difference between the two markers.
9. Use the 99 % power bandwidth function of the spectrum analyzer and report the measured bandwidth.



3.7 Conducted Band Edge

3.7.1 Description of Conducted Band Edge Measurement

27.53(l)(2)

For mobile operations in the 3700-3980 MHz band, the conducted power of any emission outside the licensee's authorized bandwidth shall not exceed -13 dBm/MHz. Compliance with this paragraph is based on the use of measurement instrumentation employing a resolution bandwidth of 1 megahertz or greater. However, in the 1 megahertz bands immediately outside and adjacent to the licensee's frequency block, the minimum resolution bandwidth for the measurement shall be either one percent of the emission bandwidth of the fundamental emission of the transmitter or 350 kHz. In the bands between 1 and 5 MHz removed from the licensee's frequency block, the minimum resolution bandwidth for the measurement shall be 500 kHz.

3.7.2 Test Procedures

1. The testing follows ANSI C63.26 section 5.7
2. The EUT was connected to spectrum analyzer and system simulator via a power divider.
3. The band edges of low and high channels for the highest RF powers were measured.
4. Set RBW \geq 1% EBW in the 1MHz band immediately outside and adjacent to the band edge.
5. Beyond the 1 MHz band from the band edge, RBW=1MHz was used or a narrower RBW was used (generally limited to no less than 1% of the OBW) and the measured power was integrated over the full required measurement bandwidth.
6. Set spectrum analyzer with RMS detector.
7. The RF fundamental frequency should be excluded against the limit line in the operating frequency band.
8. Checked that all the results comply with the emission limit line.

Example:

$$\begin{aligned} & \text{The limit line is derived from } 43 + 10\log(P)\text{dB below the transmitter power } P(\text{Watts}) \\ & = P(\text{W}) - [43 + 10\log(P)] \text{ (dB)} \\ & = [30 + 10\log(P)] \text{ (dBm)} - [43 + 10\log(P)] \text{ (dB)} = -13\text{dBm}. \end{aligned}$$

9. When using the integration method, the starting frequency of the integration shall be centered at one-half of the RBW away from the band edge.



3.8 Conducted Spurious Emission

3.8.1 Description of Conducted Spurious Emission Measurement

The power of any emission outside of the authorized operating frequency ranges must be lower than the transmitter power (P) by a factor of at least $43 + 10 \log (P)$ dB.

It is measured by means of a calibrated spectrum analyzer and scanned from 30 MHz up to a frequency including its 10th harmonic.

3.8.2 Test Procedures

1. The testing follows ANSI C63.26 section 5.7
2. The EUT was connected to spectrum analyzer and system simulator via a power divider.
3. The RF output of EUT was connected to the spectrum analyzer by RF cable and attenuator. The path loss was compensated to the results for each measurement.
4. The middle channel for the highest RF power within the transmitting frequency was measured.
5. The conducted spurious emission for the whole frequency range was taken.
6. Make the measurement with the spectrum analyzer's RBW = 1MHz, VBW = 3MHz.
7. Set spectrum analyzer with RMS detector.
8. Taking the record of maximum spurious emission.
9. The RF fundamental frequency should be excluded against the limit line in the operating frequency band.
10. The limit line is derived from $43 + 10\log(P)$ dB below the transmitter power P(Watts)
= P(W)- [43 + 10log(P)] (dB)
= [30 + 10log(P)] (dBm) - [43 + 10log(P)] (dB)
= -13dBm.



3.9 Frequency Stability

3.9.1 Description of Frequency Stability Measurement

The frequency stability shall be measured by variation of ambient temperature and variation of primary supply voltage to ensure that the fundamental emission stays within the authorized frequency block. The frequency stability of the transmitter shall be maintained within $\pm 0.00025\%$ ($\pm 2.5\text{ppm}$) of the center frequency.

3.9.2 Test Procedures for Temperature Variation

1. The testing follows ANSI C63.26 section 5.6.4
2. The EUT was set up in the thermal chamber and connected with the system simulator.
3. With power OFF, the temperature was decreased to -30°C and the EUT was stabilized before testing. Power was applied and the maximum change in frequency was recorded within one minute.
4. With power OFF, the temperature was raised in 10°C step up to 50°C . The EUT was stabilized at each step for at least half an hour. Power was applied and the maximum frequency change was recorded within one minute.

3.9.3 Test Procedures for Voltage Variation

1. The testing follows ANSI C63.26 section 5.6.5
2. The EUT was placed in a temperature chamber at $20\pm 5^{\circ}\text{C}$ and connected with the system simulator.
3. The power supply voltage to the EUT was varied from 85% to 115% of the nominal value for other than hand carried battery equipment.
4. For hand carried, battery powered equipment, reduce the primary ac or dc supply voltage to the battery operating end point, which shall be specified by the manufacturer.
5. The variation in frequency was measured for the worst case.

4 Radiated Test Items

4.1 Measuring Instruments

See list of measuring instruments of this test report.

4.2 Test Setup

4.2.1 For radiated test below 30MHz

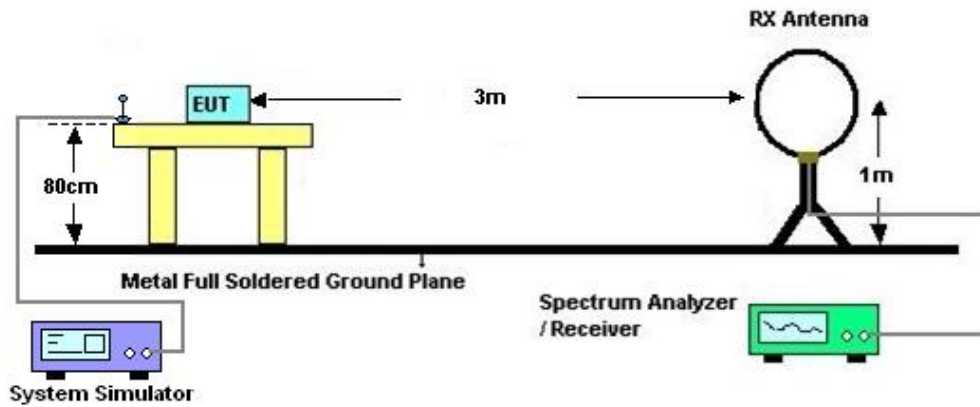

4.2.2 For radiated test from 30MHz to 1GHz

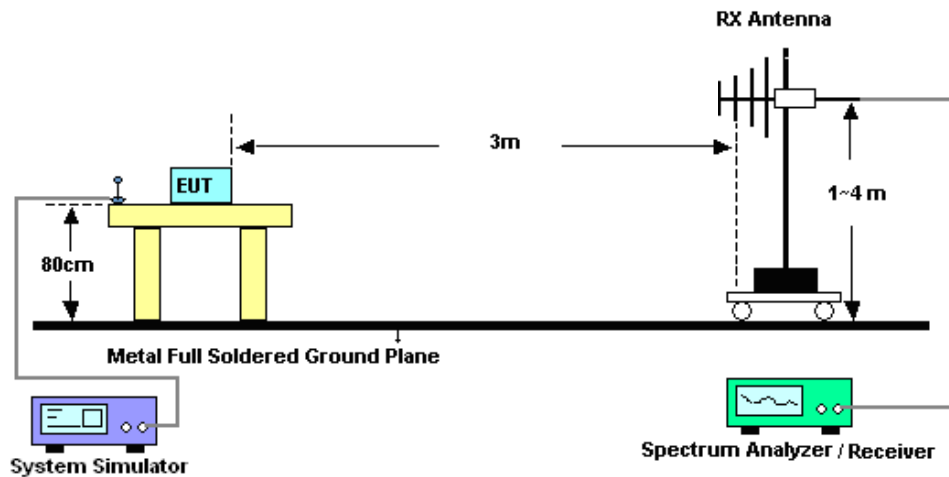

4.2.3 For radiated test above 1GHz

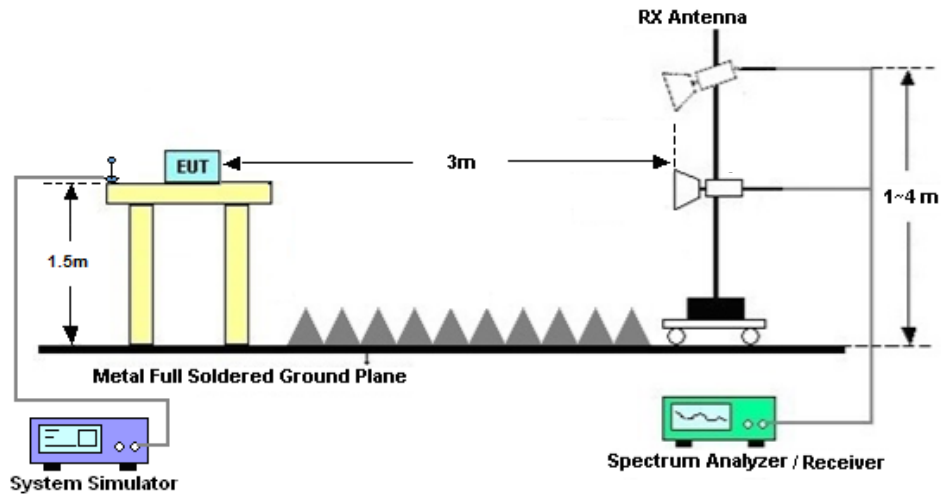

4.3 Test Result of Radiated Test

The low frequency, which started from 9 kHz to 30MHz, was pre-scanned and the result which was 20dB lower than the limit line was not reported.

Please refer to Appendix B.



4.4 Radiated Spurious Emission

4.4.1 Description of Radiated Spurious Emission

The radiated spurious emission was measured by substitution method according to ANSI C63.26. The power of any emission outside of the authorized operating frequency ranges must be attenuated below the transmitter power (P) by a factor of at least $43 + 10 \log(P)$ dB.

The spectrum is scanned from 30 MHz up to a frequency including its 10th harmonic.

4.4.2 Test Procedures

6. The testing follows ANSI C63.26 Section 5.5
7. The EUT was placed on a turntable with 0.8 meter height for frequency below 1GHz and 1.5 meter height for frequency above 1GHz respectively above ground.
8. The EUT was set 3 meters from the receiving antenna mounted on the antenna tower.
9. The table was rotated 360 degrees to determine the position of the highest spurious emission.
10. The height of the receiving antenna is varied between 1m to 4m to search the maximum spurious emission for both horizontal and vertical polarizations.
11. During the measurement, the system simulator parameters were set to force the EUT transmitting at maximum output power.
12. Make the measurement with the spectrum analyzer's RBW = 1MHz, VBW = 3MHz, taking the record of maximum spurious emission.
13. A horn antenna was substituted in place of the EUT and was driven by a signal generator.
14. Tune the output power of signal generator to the same emission level with EUT maximum spurious emission.
15. $EIRP \text{ (dBm)} = S.G. \text{ Power} - Tx \text{ Cable Loss} + Tx \text{ Antenna Gain}$
16. $ERP \text{ (dBm)} = EIRP - 2.15$
17. The RF fundamental frequency should be excluded against the limit line in the operating frequency band.

The limit line is derived from $43 + 10\log(P)$ dB below the transmitter power P(Watts)
= $P(W) - [43 + 10\log(P)] \text{ (dB)}$
= $[30 + 10\log(P)] \text{ (dBm)} - [43 + 10\log(P)] \text{ (dB)}$
= -13dBm.



5 List of Measuring Equipment

Instrument	Manufacturer	Model No.	Serial No.	Characteristics	Calibration Date	Test Date	Due Date	Remark
Spectrum Analyzer	R&S	FSV40	101040	10Hz~40GHz	Oct. 12, 2022	Jun. 14, 2023	Oct. 11, 2023	Conducted (TH01-KS)
Power divider	STI	STI08-0055	-	0.5~40GHz	/	Jun. 14, 2023	/	Conducted (TH01-KS)
Temperature & humidity chamber	Hongzhan	LP-150U	H2014011440	-40~+150°C 20%~95%RH	Jul. 15, 2022	Jun. 14, 2023	Jul. 14, 2023	Conducted (TH01-KS)
EMI Test Receiver	Keysight	N9038A	MY56400004	3Hz~8.5GHz;Max 30dBm	Oct. 13, 2022	Jul. 19, 2023	Oct. 12, 2023	Radiation (03CH04-KS)
EXA Spectrum Analyzer	Keysight	N9010B	MY57471079	10Hz-44G,MAX 30dB	Oct. 12, 2022	Jul. 19, 2023	Oct. 11, 2023	Radiation (03CH04-KS)
Loop Antenna	R&S	HFH2-Z2E	101125	9kHz~30MHz	Sep. 22, 2022	Jul. 19, 2023	Sep. 21, 2023	Radiation (03CH04-KS)
Bilog Antenna	TeseQ	CBL6111D	49922	30MHz-1GHz	Apr. 09, 2023	Jul. 19, 2023	Apr. 08, 2024	Radiation (03CH04-KS)
Horn Antenna	Schwarzbeck	BBHA9120D	1284	1GHz~18GHz	Oct. 16, 2022	Jul. 19, 2023	Oct. 15, 2023	Radiation (03CH04-KS)
SHF-EHF Horn	Com-power	AH-840	101070	18GHz~40GHz	Jan. 08, 2023	Jul. 19, 2023	Jan. 07, 2024	Radiation (03CH04-KS)
Amplifier	SONOMA	310N	380827	9KHz-1GHz	Jul. 10, 2023	Jul. 19, 2023	Jul. 09, 2024	Radiation (03CH04-KS)
Amplifier	MITEQ	EM18G40G GA	060728	18~40GHz	Jan. 05, 2023	Jul. 19, 2023	Jan. 04, 2024	Radiation (03CH04-KS)
high gain Amplifier	EM	EM01G18G A	060840	1Ghz-18Ghz	Oct. 12, 2022	Jul. 19, 2023	Oct. 11, 2023	Radiation (03CH04-KS)
Amplifier	Agilent	8449B	3008A02370	1Ghz-18Ghz	Oct. 12, 2022	Jul. 19, 2023	Oct. 11, 2023	Radiation (03CH04-KS)
AC Power Source	Chroma	61601	F104090004	N/A	NCR	Jul. 19, 2023	NCR	Radiation (03CH04-KS)
Turn Table	ChamPro	EM 1000-T	060762-T	0~360 degree	NCR	Jul. 19, 2023	NCR	Radiation (03CH04-KS)
Antenna Mast	ChamPro	EM 1000-A	060762-A	1 m~4 m	NCR	Jul. 19, 2023	NCR	Radiation (03CH04-KS)

NCR: No Calibration Required



6 Measurement Uncertainty

The measurement uncertainties shown below were calculated in accordance with the requirements of ANSI 63.26-2015. All the measurement uncertainty value were shown with a coverage K=2 to indicate 95% level of confidence. The measurement data show herein meets or exceeds the CISPR measurement uncertainty values specified in CISPR 16-4-2 and can be compared directly to specified limit to determine compliance.

Uncertainty of Conducted Measurement

Test Item	Uncertainty
Conducted Power	±0.46 dB
Conducted Emissions	±2.26 dB
Occupied Channel Bandwidth	±0.1 %

Uncertainty of Radiated Emission Measurement (30 MHz ~ 1000 MHz)

Measuring Uncertainty for a Level of Confidence of 95% (U = 2Uc(y))	3.82dB
---	--------

Uncertainty of Radiated Emission Measurement (1 GHz ~ 18 GHz)

Measuring Uncertainty for a Level of Confidence of 95% (U = 2Uc(y))	3.56dB
---	--------

Uncertainty of Radiated Emission Measurement (18 GHz ~ 40 GHz)

Measuring Uncertainty for a Level of Confidence of 95% (U = 2Uc(y))	3.54dB
---	--------

----- THE END -----



Appendix A. Test Results of Conducted Test

Test Engineer :	Simle Wang	Temperature :	22~23°C
		Relative Humidity :	40~42%

FR1 N77 (ANT5)

Transmitter Conducted Output Power And EIRP, (G_T - L_C)=-0.26dBi

NR Band	SCS	Band Width	Arfcn	Freq(MHz)	Modulation	RB	Conducted Power(dBm)	EIRP(dBm)	EIRP(W)
77	30	100	650000	3750	DFT-s-OFDM PI/2 BPSK	135@67	24.64	24.38	0.2742
77	30	100	650000	3750	DFT-s-OFDM PI/2 BPSK	1@1	24.33	24.07	0.2553
77	30	100	650000	3750	DFT-s-OFDM PI/2 BPSK	1@27 1	24.41	24.15	0.2600
77	30	100	650000	3750	DFT-s-OFDM QPSK	135@67	24.6	24.34	0.2716
77	30	100	650000	3750	DFT-s-OFDM QPSK	1@1	24.33	24.07	0.2553
77	30	100	650000	3750	DFT-s-OFDM QPSK	1@27 1	24.38	24.12	0.2582
77	30	100	650000	3750	DFT-s-OFDM 16 QAM	135@67	23.61	23.35	0.2163
77	30	100	650000	3750	DFT-s-OFDM 16 QAM	1@1	23.13	22.87	0.1936
77	30	100	650000	3750	DFT-s-OFDM 16 QAM	1@27 1	23.15	22.89	0.1945
77	30	100	650000	3750	DFT-s-OFDM 64 QAM	135@67	22.07	21.81	0.1517
77	30	100	650000	3750	DFT-s-OFDM 64 QAM	1@1	22.12	21.86	0.1535
77	30	100	650000	3750	DFT-s-OFDM 64 QAM	1@27 1	22.16	21.9	0.1549
77	30	100	650000	3750	DFT-s-OFDM 256 QAM	135@67	20.04	19.78	0.0951
77	30	100	650000	3750	DFT-s-OFDM 256 QAM	1@1	19.73	19.47	0.0885
77	30	100	650000	3750	DFT-s-OFDM 256 QAM	1@27 1	19.83	19.57	0.0906
77	30	100	650000	3750	CP-OFDM QPSK	137@68	23.09	22.83	0.1919
77	30	100	650000	3750	CP-OFDM QPSK	1@1	22.79	22.53	0.1791
77	30	100	650000	3750	CP-OFDM QPSK	1@27 1	22.75	22.49	0.1774
77	30	100	656000	3840	DFT-s-OFDM PI/2 BPSK	135@67	24.52	24.26	0.2667
77	30	100	656000	3840	DFT-s-OFDM PI/2 BPSK	1@1	24.45	24.19	0.2624
77	30	100	656000	3840	DFT-s-OFDM PI/2 BPSK	1@27 1	24.35	24.09	0.2564
77	30	100	656000	3840	DFT-s-OFDM QPSK	135@67	24.54	24.28	0.2679
77	30	100	656000	3840	DFT-s-OFDM QPSK	1@1	24.37	24.11	0.2576
77	30	100	656000	3840	DFT-s-OFDM QPSK	1@27 1	24.34	24.08	0.2559
77	30	100	656000	3840	DFT-s-OFDM 16 QAM	135@67	23.57	23.31	0.2143
77	30	100	656000	3840	DFT-s-OFDM 16 QAM	1@1	23.12	22.86	0.1932
77	30	100	656000	3840	DFT-s-OFDM 16 QAM	1@27 1	23.11	22.85	0.1928
77	30	100	656000	3840	DFT-s-OFDM 64 QAM	135@67	22.04	21.78	0.1507
77	30	100	656000	3840	DFT-s-OFDM 64 QAM	1@1	22.22	21.96	0.1570

QAM									
77	30	100	656000	3840	DFT-s-OFDM 64 QAM	1@27 1	22.11	21.85	0.1531
77	30	100	656000	3840	DFT-s-OFDM 256 QAM	135@ 67	20.02	19.76	0.0946
77	30	100	656000	3840	DFT-s-OFDM 256 QAM	1@1	19.86	19.6	0.0912
77	30	100	656000	3840	DFT-s-OFDM 256 QAM	1@27 1	19.75	19.49	0.0889
77	30	100	656000	3840	CP-OFDM QPSK	137@ 68	23.01	22.75	0.1884
77	30	100	656000	3840	CP-OFDM QPSK	1@1	22.89	22.63	0.1832
77	30	100	656000	3840	CP-OFDM QPSK	1@27 1	22.71	22.45	0.1758
77	30	100	662000	3930	DFT-s-OFDM PI/2 BPSK	135@ 67	24.73	24.47	0.2799
77	30	100	662000	3930	DFT-s-OFDM PI/2 BPSK	1@1	24.32	24.06	0.2547
77	30	100	662000	3930	DFT-s-OFDM PI/2 BPSK	1@27 1	24.82	24.56	0.2858
77	30	100	662000	3930	DFT-s-OFDM QPSK	135@ 67	24.7	24.44	0.2780
77	30	100	662000	3930	DFT-s-OFDM QPSK	1@1	24.25	23.99	0.2506
77	30	100	662000	3930	DFT-s-OFDM QPSK	1@27 1	24.77	24.51	0.2825
77	30	100	662000	3930	DFT-s-OFDM 16 QAM	135@ 67	23.73	23.47	0.2223
77	30	100	662000	3930	DFT-s-OFDM 16 QAM	1@1	23	22.74	0.1879
77	30	100	662000	3930	DFT-s-OFDM 16 QAM	1@27 1	23.52	23.26	0.2118
77	30	100	662000	3930	DFT-s-OFDM 64 QAM	135@ 67	22.23	21.97	0.1574
77	30	100	662000	3930	DFT-s-OFDM 64 QAM	1@1	22.04	21.78	0.1507
77	30	100	662000	3930	DFT-s-OFDM 64 QAM	1@27 1	22.58	22.32	0.1706
77	30	100	662000	3930	DFT-s-OFDM 256 QAM	135@ 67	20.19	19.93	0.0984
77	30	100	662000	3930	DFT-s-OFDM 256 QAM	1@1	19.7	19.44	0.0879
77	30	100	662000	3930	DFT-s-OFDM 256 QAM	1@27 1	20.22	19.96	0.0991
77	30	100	662000	3930	CP-OFDM QPSK	137@ 68	23.21	22.95	0.1972
77	30	100	662000	3930	CP-OFDM QPSK	1@1	22.65	22.39	0.1734
77	30	100	662000	3930	CP-OFDM QPSK	1@27 1	23.19	22.93	0.1963
77	30	20	647334	3710.01	DFT-s-OFDM PI/2 BPSK	1@1	24.46	24.2	0.2630
77	30	20	647334	3710.01	DFT-s-OFDM QPSK	1@1	24.47	24.21	0.2636
77	30	20	647334	3710.01	DFT-s-OFDM 16 QAM	1@1	23.24	22.98	0.1986
77	30	20	656000	3840	DFT-s-OFDM PI/2 BPSK	1@1	24.64	24.38	0.2742
77	30	20	656000	3840	DFT-s-OFDM QPSK	1@1	24.7	24.44	0.2780
77	30	20	656000	3840	DFT-s-OFDM 16 QAM	1@1	23.41	23.15	0.2065
77	30	20	664666	3969.99	DFT-s-OFDM PI/2 BPSK	1@1	24.66	24.4	0.2754
77	30	20	664666	3969.99	DFT-s-OFDM QPSK	1@1	24.67	24.41	0.2761
77	30	20	664666	3969.99	DFT-s-OFDM 16 QAM	1@1	23.41	23.15	0.2065

77	30	30	647668	3715.02	DFT-s-OFDM PI/2 BPSK	1@1	24.38	24.12	0.2582
77	30	30	647668	3715.02	DFT-s-OFDM QPSK	1@1	24.4	24.14	0.2594
77	30	30	647668	3715.02	DFT-s-OFDM 16 QAM	1@1	23.18	22.92	0.1959
77	30	30	656000	3840	DFT-s-OFDM PI/2 BPSK	1@1	24.58	24.32	0.2704
77	30	30	656000	3840	DFT-s-OFDM QPSK	1@1	24.5	24.24	0.2655
77	30	30	656000	3840	DFT-s-OFDM 16 QAM	1@1	23.37	23.11	0.2046
77	30	30	664332	3964.98	DFT-s-OFDM PI/2 BPSK	1@1	24.49	24.23	0.2649
77	30	30	664332	3964.98	DFT-s-OFDM QPSK	1@1	24.52	24.26	0.2667
77	30	30	664332	3964.98	DFT-s-OFDM 16 QAM	1@1	23.18	22.92	0.1959
77	30	40	648000	3720	DFT-s-OFDM PI/2 BPSK	1@1	24.33	24.07	0.2553
77	30	40	648000	3720	DFT-s-OFDM QPSK	1@1	24.37	24.11	0.2576
77	30	40	648000	3720	DFT-s-OFDM 16 QAM	1@1	23.17	22.91	0.1954
77	30	40	656000	3840	DFT-s-OFDM PI/2 BPSK	1@1	24.5	24.24	0.2655
77	30	40	656000	3840	DFT-s-OFDM QPSK	1@1	24.47	24.21	0.2636
77	30	40	656000	3840	DFT-s-OFDM 16 QAM	1@1	23.28	23.02	0.2004
77	30	40	664000	3960	DFT-s-OFDM PI/2 BPSK	1@1	24.59	24.33	0.2710
77	30	40	664000	3960	DFT-s-OFDM QPSK	1@1	24.6	24.34	0.2716
77	30	40	664000	3960	DFT-s-OFDM 16 QAM	1@1	23.34	23.08	0.2032
77	30	50	648334	3725.01	DFT-s-OFDM PI/2 BPSK	1@1	24.37	24.11	0.2576
77	30	50	648334	3725.01	DFT-s-OFDM QPSK	1@1	24.43	24.17	0.2612
77	30	50	648334	3725.01	DFT-s-OFDM 16 QAM	1@1	23.12	22.86	0.1932
77	30	50	656000	3840	DFT-s-OFDM PI/2 BPSK	1@1	24.47	24.21	0.2636
77	30	50	656000	3840	DFT-s-OFDM QPSK	1@1	24.49	24.23	0.2649
77	30	50	656000	3840	DFT-s-OFDM 16 QAM	1@1	23.23	22.97	0.1982
77	30	50	663666	3954.99	DFT-s-OFDM PI/2 BPSK	1@1	24.5	24.24	0.2655
77	30	50	663666	3954.99	DFT-s-OFDM QPSK	1@1	24.56	24.3	0.2692
77	30	50	663666	3954.99	DFT-s-OFDM 16 QAM	1@1	23.17	22.91	0.1954
77	30	60	648668	3730.02	DFT-s-OFDM PI/2 BPSK	1@1	24.3	24.04	0.2535
77	30	60	648668	3730.02	DFT-s-OFDM QPSK	1@1	24.37	24.11	0.2576
77	30	60	648668	3730.02	DFT-s-OFDM 16 QAM	1@1	23.02	22.76	0.1888
77	30	60	656000	3840	DFT-s-OFDM PI/2 BPSK	1@1	24.44	24.18	0.2618
77	30	60	656000	3840	DFT-s-OFDM QPSK	1@1	24.5	24.24	0.2655
77	30	60	656000	3840	DFT-s-OFDM 16 QAM	1@1	23.16	22.9	0.1950
77	30	60	663332	3949.98	DFT-s-OFDM PI/2 BPSK	1@1	24.41	24.15	0.2600

77	30	60	663332	3949.98	DFT-s-OFDM QPSK	1@1	24.37	24.11	0.2576
77	30	60	663332	3949.98	DFT-s-OFDM 16 QAM	1@1	23.14	22.88	0.1941
77	30	80	649334	3740.01	DFT-s-OFDM PI/2 BPSK	1@1	24.26	24	0.2512
77	30	80	649334	3740.01	DFT-s-OFDM QPSK	1@1	24.34	24.08	0.2559
77	30	80	649334	3740.01	DFT-s-OFDM 16 QAM	1@1	22.94	22.68	0.1854
77	30	80	656000	3840	DFT-s-OFDM PI/2 BPSK	1@1	24.42	24.16	0.2606
77	30	80	656000	3840	DFT-s-OFDM QPSK	1@1	24.52	24.26	0.2667
77	30	80	656000	3840	DFT-s-OFDM 16 QAM	1@1	23.07	22.81	0.1910
77	30	80	662666	3939.99	DFT-s-OFDM PI/2 BPSK	1@1	24.22	23.96	0.2489
77	30	80	662666	3939.99	DFT-s-OFDM QPSK	1@1	24.34	24.08	0.2559
77	30	80	662666	3939.99	DFT-s-OFDM 16 QAM	1@1	22.96	22.7	0.1862
77	30	90	649668	3745.02	DFT-s-OFDM PI/2 BPSK	1@1	24.3	24.04	0.2535
77	30	90	649668	3745.02	DFT-s-OFDM QPSK	1@1	24.35	24.09	0.2564
77	30	90	649668	3745.02	DFT-s-OFDM 16 QAM	1@1	23.01	22.75	0.1884
77	30	90	656000	3840	DFT-s-OFDM PI/2 BPSK	1@1	24.38	24.12	0.2582
77	30	90	656000	3840	DFT-s-OFDM QPSK	1@1	24.49	24.23	0.2649
77	30	90	656000	3840	DFT-s-OFDM 16 QAM	1@1	23.09	22.83	0.1919
77	30	90	662332	3934.98	DFT-s-OFDM PI/2 BPSK	1@1	24.17	23.91	0.2460
77	30	90	662332	3934.98	DFT-s-OFDM QPSK	1@1	24.2	23.94	0.2477
77	30	90	662332	3934.98	DFT-s-OFDM 16 QAM	1@1	22.8	22.54	0.1795

Frequency Stability

NR Band	SCS (kHz)	Bandwidth (MHz)	Arfcn	Freq (MHz)	Modulation	RB	Deviation (ppm)	Verdict	Environment
77	30	20	656000	3840.0	DFT-s-OFDM QPSK	50@0	-0.0011	PASS	NV
77	30	20	656000	3840.0	DFT-s-OFDM QPSK	50@0	0.0029	PASS	LV
77	30	20	656000	3840.0	DFT-s-OFDM QPSK	50@0	0.0027	PASS	HV
77	30	20	656000	3840.0	DFT-s-OFDM QPSK	50@0	0.0019	PASS	-30°C
77	30	20	656000	3840.0	DFT-s-OFDM QPSK	50@0	0.0025	PASS	-20°C
77	30	20	656000	3840.0	DFT-s-OFDM QPSK	50@0	0.0039	PASS	-10°C
77	30	20	656000	3840.0	DFT-s-OFDM QPSK	50@0	0.0041	PASS	0°C
77	30	20	656000	3840.0	DFT-s-OFDM QPSK	50@0	-0.0029	PASS	10°C
77	30	20	656000	3840.0	DFT-s-OFDM QPSK	50@0	0.0034	PASS	20°C
77	30	20	656000	3840.0	DFT-s-OFDM QPSK	50@0	0.0032	PASS	30°C
77	30	20	656000	3840.0	DFT-s-OFDM QPSK	50@0	0.0021	PASS	40°C
77	30	20	656000	3840.0	DFT-s-OFDM QPSK	50@0	0.0028	PASS	50°C

Peak to Average Ratio

NR Band	SCS (kHz)	Bandwidth (MHz)	Arfcn	Freq (MHz)	Modulation	RB	Result (dB)	Limit (dB)	Verdict
77	30	20	656000	3840.0	DFT-s-OFDM PI/2 BPSK	50@0	7.4	13	PASS
77	30	20	656000	3840.0	DFT-s-OFDM PI/2 BPSK	1@0	7.4	13	PASS
77	30	20	656000	3840.0	DFT-s-OFDM QPSK	50@0	8.39	13	PASS
77	30	20	656000	3840.0	DFT-s-OFDM QPSK	1@0	8.02	13	PASS

N77(20M)_DFT-s-OFDM_PI_2-BPSK_Outer_Full_Mid_CH



N77(20M)_DFT-s-OFDM_PI_2-BPSK_Edge_1RB_Left_Mid_CH



N77(20M)_DFT-s-OFDM_QPSK_Outer_Full_Mid_CH

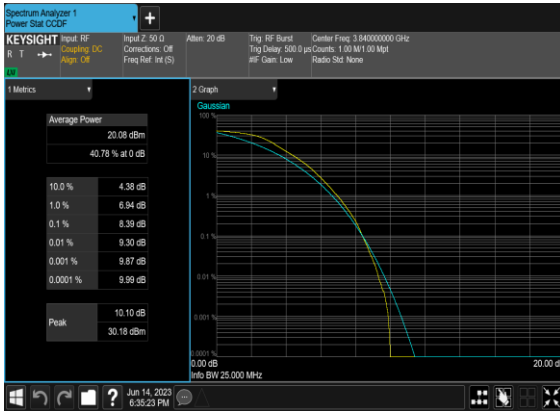

N77(20M)_DFT-s-OFDM_QPSK_Edge_1RB_Left_Mid_CH

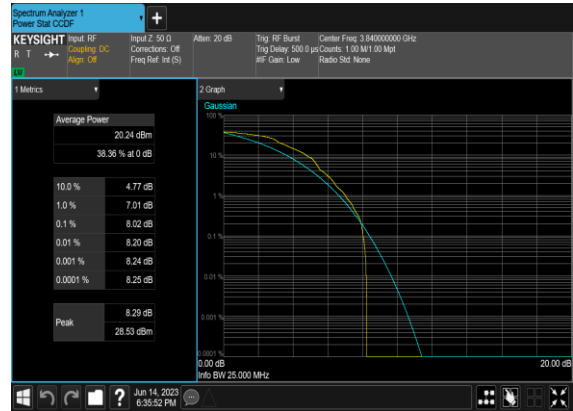

Occupied Bandwidth

NR Band	SCS (kHz)	Bandwidth (MHz)	Arfcn	Freq (MHz)	Modulation	RB	OBW (MHz)	26dB BW (MHz)
77	30	20	656000	3840.0	CP-OFDM QPSK	51@0	18.173	18.93
77	30	20	656000	3840.0	CP-OFDM 16 QAM	51@0	18.197	19.06
77	30	20	656000	3840.0	CP-OFDM 64 QAM	51@0	18.128	18.94
77	30	20	656000	3840.0	CP-OFDM 256 QAM	51@0	18.216	19.05

N77(20M)_CP-OFDM_QPSK_Outer_Full_Mid_CH

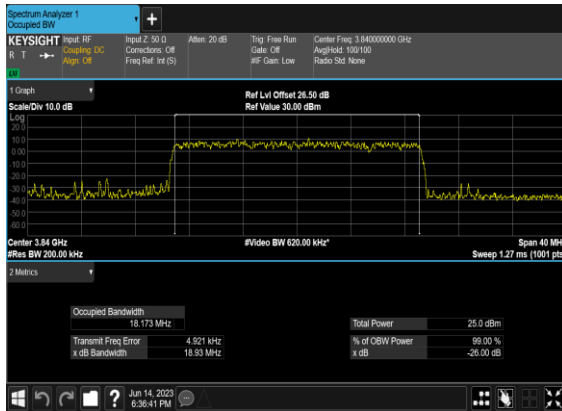

N77(20M)_CP-OFDM_16QAM_Outer_Full_Mid_CH

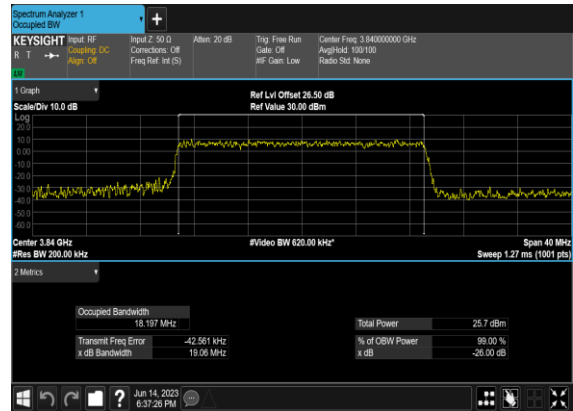

N77(20M)_CP-OFDM_64QAM_Outer_Full_Mid_CH

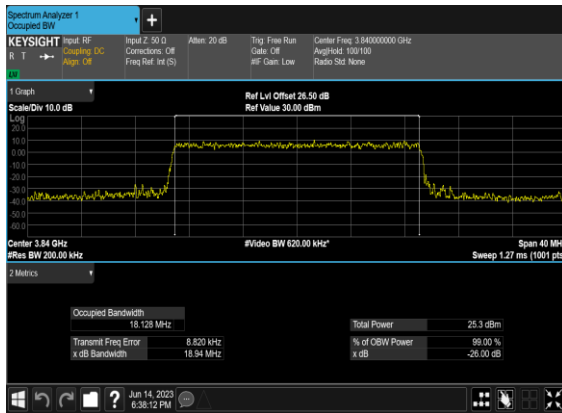

N77(20M)_CP-OFDM_256QAM_Outer_Full_Mid_CH

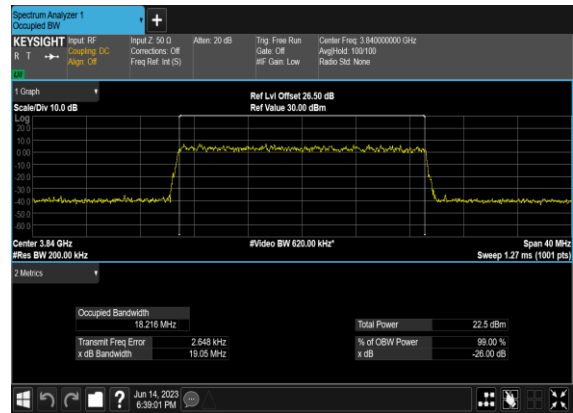

Conducted Spurious Emissions

NR Band	SCS (kHz)	Bandwidth (MHz)	Arfcn	Freq (MHz)	Modulation	RB	Result	Verdict
77	30	20	647334	3710.01	DFT-s-OFDM BPSK	1@0	see graph	---
77	30	20	647334	3710.01	DFT-s-OFDM BPSK	1@0	see graph	PASS
77	30	20	647334	3710.01	DFT-s-OFDM BPSK	1@0	see graph	PASS
77	30	20	647334	3710.01	DFT-s-OFDM QPSK	1@0	see graph	---
77	30	20	647334	3710.01	DFT-s-OFDM QPSK	1@0	see graph	PASS
77	30	20	647334	3710.01	DFT-s-OFDM QPSK	1@0	see graph	PASS
77	30	20	656000	3840.0	DFT-s-OFDM BPSK	1@0	see graph	---
77	30	20	656000	3840.0	DFT-s-OFDM BPSK	1@0	see graph	PASS
77	30	20	656000	3840.0	DFT-s-OFDM BPSK	1@0	see graph	PASS
77	30	20	656000	3840.0	DFT-s-OFDM QPSK	1@0	see graph	---
77	30	20	656000	3840.0	DFT-s-OFDM QPSK	1@0	see graph	PASS
77	30	20	656000	3840.0	DFT-s-OFDM QPSK	1@0	see graph	PASS
77	30	20	664666	3969.99	DFT-s-OFDM BPSK	1@0	see graph	---
77	30	20	664666	3969.99	DFT-s-OFDM BPSK	1@0	see graph	PASS
77	30	20	664666	3969.99	DFT-s-OFDM BPSK	1@0	see graph	PASS
77	30	20	664666	3969.99	DFT-s-OFDM QPSK	1@0	see graph	---
77	30	20	664666	3969.99	DFT-s-OFDM QPSK	1@0	see graph	PASS
77	30	20	664666	3969.99	DFT-s-OFDM QPSK	1@0	see graph	PASS

N77(20M)_DFT-s-OFDM_BPSK_Edge_1RB_Left_Low_CH

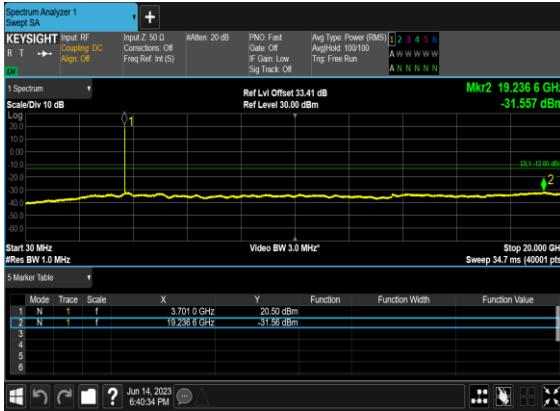

N77(20M)_DFT-s-OFDM_BPSK_Edge_1RB_Left_Low_CH

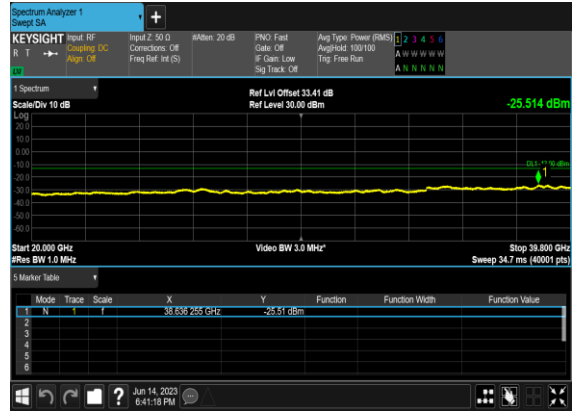

N77(20M)_DFT-s-OFDM_QPSK_Edge_1RB_Left_Low_CH

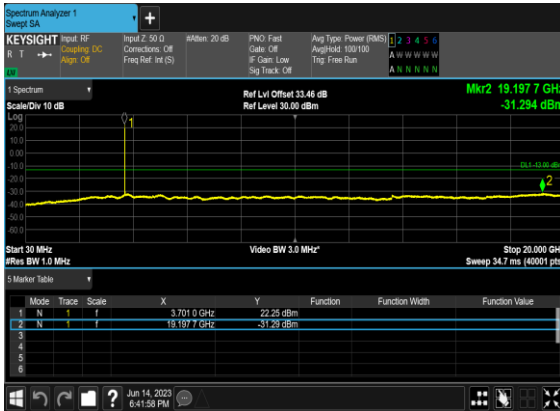

N77(20M)_DFT-s-OFDM_QPSK_Edge_1RB_Left_Low_CH

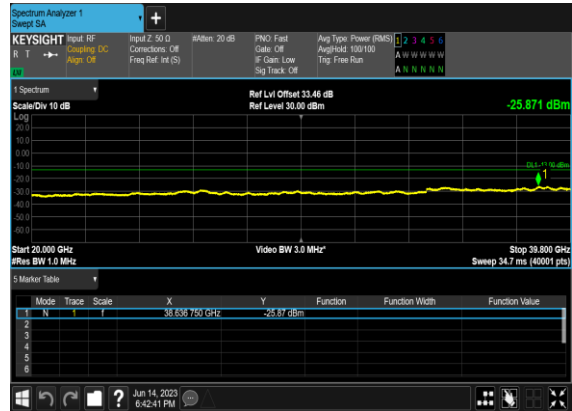

N77(20M)_DFT-s-OFDM_BPSK_Edge_1RB_Left_Mid_CH

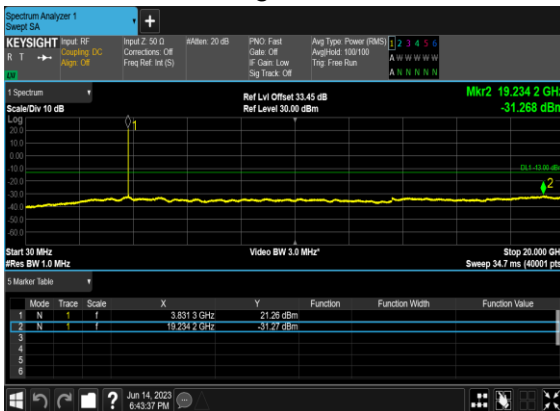

N77(20M)_DFT-s-OFDM_BPSK_Edge_1RB_Left_Mid_CH

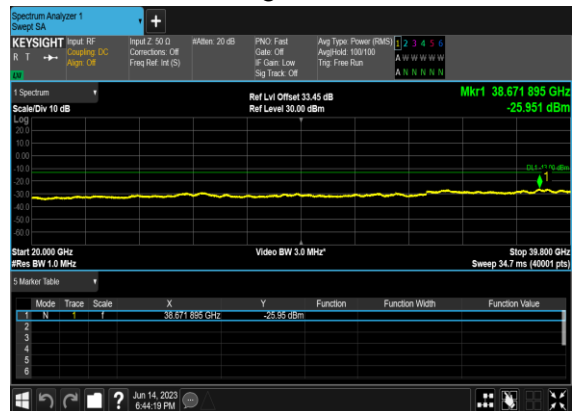

N77(20M)_DFT-s-OFDM_QPSK_Edge_1RB_Left_Mid_CH

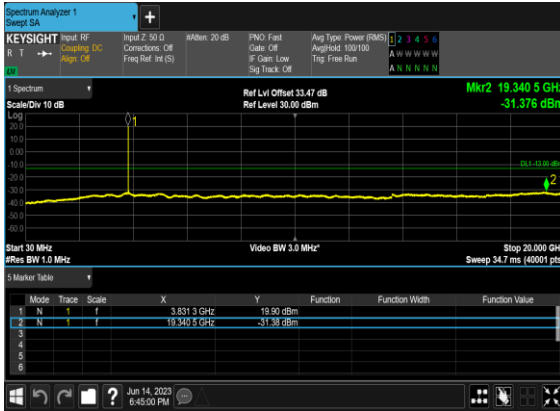

N77(20M)_DFT-s-OFDM_QPSK_Edge_1RB_Left_Mid_CH

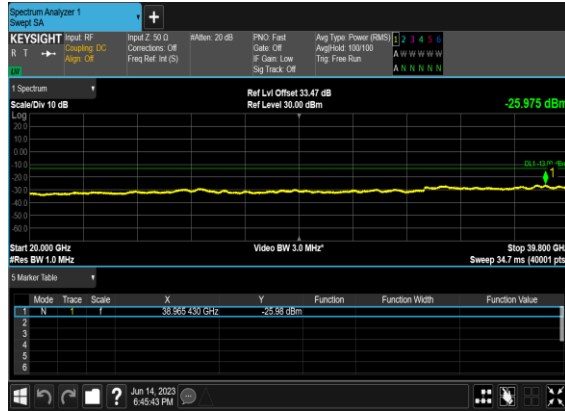

N77(20M)_DFT-s-OFDM_BPSK_Edge_1RB_Left_High_CH

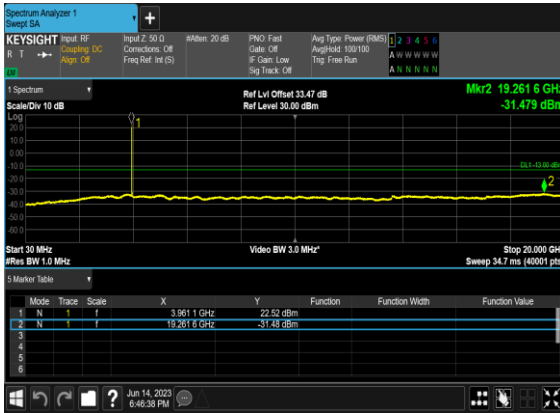

N77(20M)_DFT-s-OFDM_BPSK_Edge_1RB_Left_High_CH

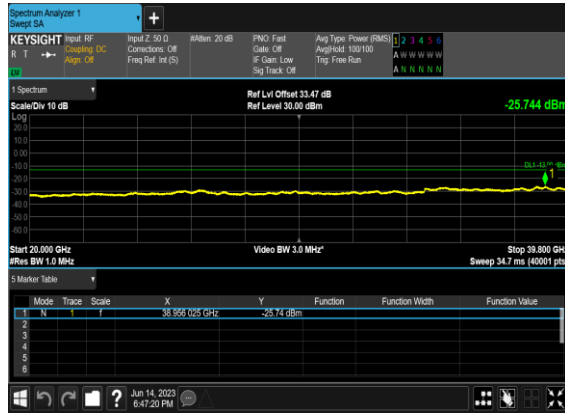

N77(20M)_DFT-s-OFDM_QPSK_Edge_1RB_Left_High_CH

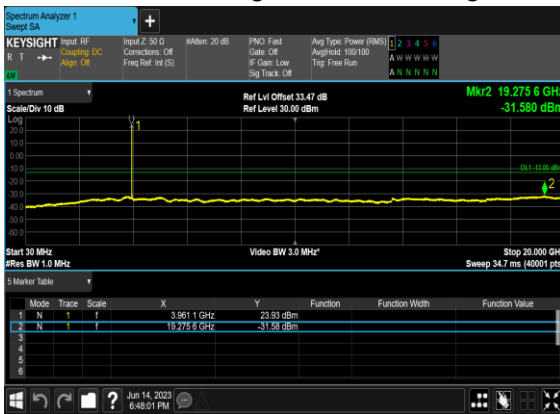

N77(20M)_DFT-s-OFDM_QPSK_Edge_1RB_Left_High_CH

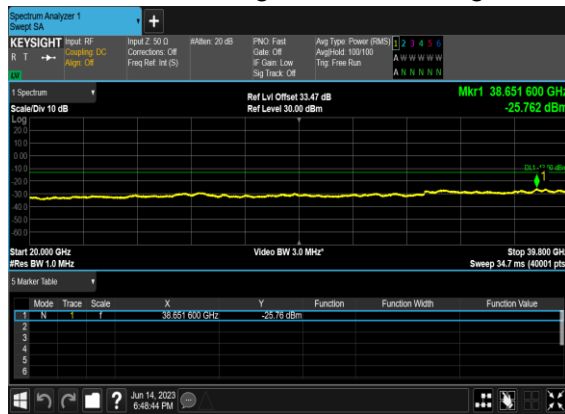

Conducted Band Edge

NR Band	SCS (kHz)	Bandwidth (MHz)	Arfcn	Freq (MHz)	Modulation	RB	Result	Verdict
77	30	20	647334	3710.01	DFT-s-OFDM BPSK	1@0	see graph	PASS
77	30	20	647334	3710.01	DFT-s-OFDM QPSK	1@0	see graph	PASS
77	30	20	647334	3710.01	DFT-s-OFDM BPSK	50@0	see graph	PASS
77	30	20	647334	3710.01	DFT-s-OFDM QPSK	50@0	see graph	PASS
77	30	20	664666	3969.99	DFT-s-OFDM BPSK	1@50	see graph	PASS
77	30	20	664666	3969.99	DFT-s-OFDM QPSK	1@50	see graph	PASS
77	30	20	664666	3969.99	DFT-s-OFDM BPSK	50@0	see graph	PASS
77	30	20	664666	3969.99	DFT-s-OFDM QPSK	50@0	see graph	PASS

N77(20M)_DFT-s-OFDM_BPSK_Edge_1RB_Left_Low_CH

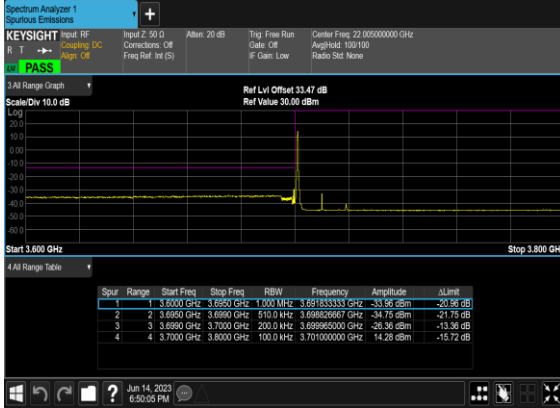

N77(20M)_DFT-s-OFDM_QPSK_Edge_1RB_Left_Low_CH

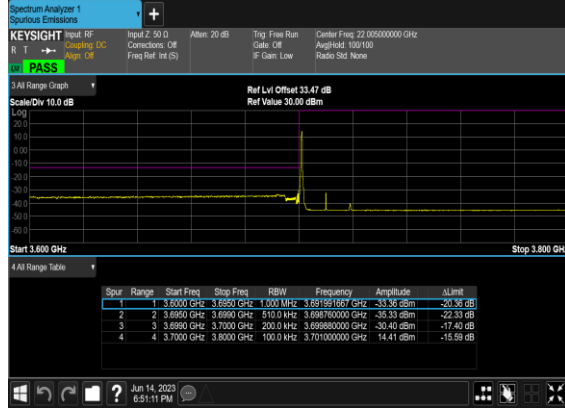

N77(20M)_DFT-s-OFDM_BPSK_Outer_Full_Low_CH

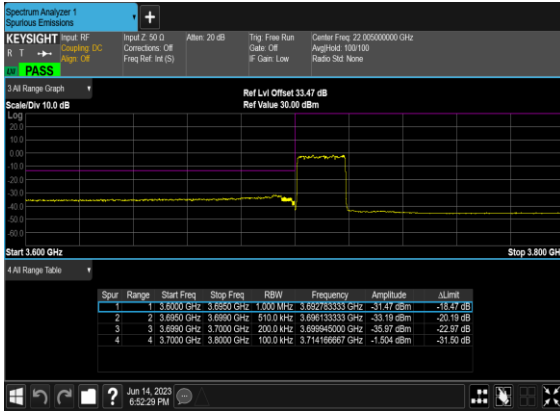

N77(20M)_DFT-s-OFDM_QPSK_Outer_Full_Low_CH

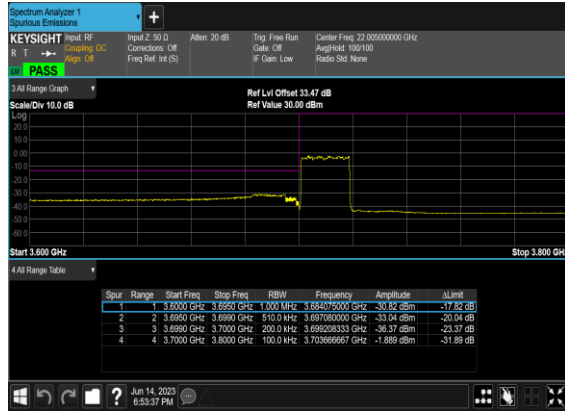

N77(20M)_DFT-s-OFDM_BPSK_Edge_1RB_Right_High_CH

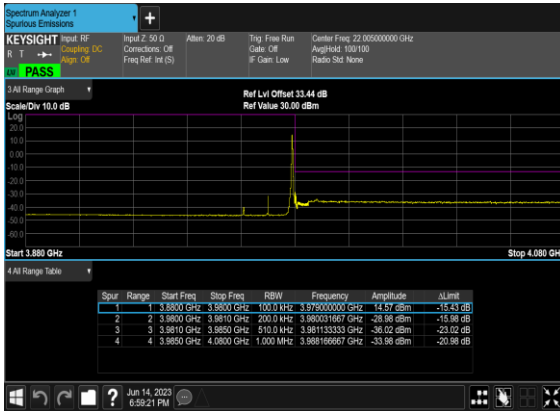

N77(20M)_DFT-s-OFDM_QPSK_Edge_1RB_Right_High_CH

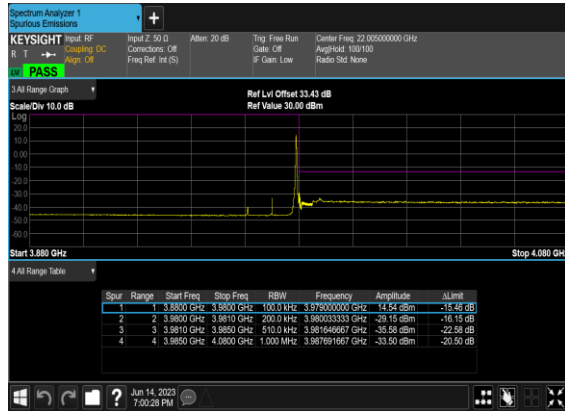

N77(20M)_DFT-s-OFDM_BPSK_Outer_Full_High_CH

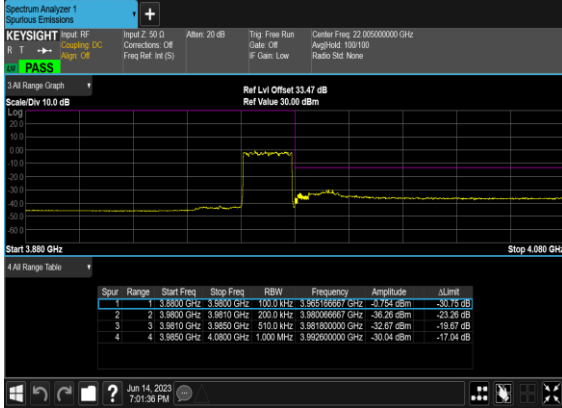

N77(20M)_DFT-s-OFDM_QPSK_Outer_Full_High_CH

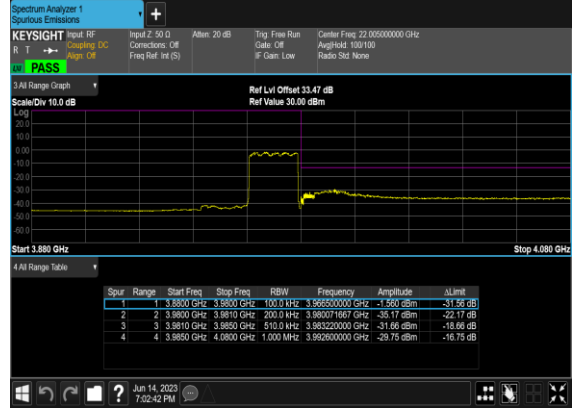

FR1 N78 (ANT5)

Transmitter Conducted Output Power And EIRP, (G_T - L_C)=-0.67dBi

NR Band	SCS	Band Width	Arfcn	Freq(MHz)	Modulation	RB	Conducted Power(dBm)	EIRP(dBm)	EIRP(W)
78	30	100	650000	3750	DFT-s-OFDM PI/2 BPSK	135@67	24.6	23.93	0.2472
78	30	100	650000	3750	DFT-s-OFDM PI/2 BPSK	1@1	24.34	23.67	0.2328
78	30	100	650000	3750	DFT-s-OFDM PI/2 BPSK	1@27 1	24.54	23.87	0.2438
78	30	100	650000	3750	DFT-s-OFDM QPSK	135@67	24.56	23.89	0.2449
78	30	100	650000	3750	DFT-s-OFDM QPSK	1@1	24.4	23.73	0.2360
78	30	100	650000	3750	DFT-s-OFDM QPSK	1@27 1	24.55	23.88	0.2443
78	30	100	650000	3750	DFT-s-OFDM 16 QAM	135@67	23.55	22.88	0.1941
78	30	100	650000	3750	DFT-s-OFDM 16 QAM	1@1	23.11	22.44	0.1754
78	30	100	650000	3750	DFT-s-OFDM 16 QAM	1@27 1	23.31	22.64	0.1837
78	30	100	650000	3750	DFT-s-OFDM 64 QAM	135@67	22.03	21.36	0.1368
78	30	100	650000	3750	DFT-s-OFDM 64 QAM	1@1	22.16	21.49	0.1409
78	30	100	650000	3750	DFT-s-OFDM 64 QAM	1@27 1	22.35	21.68	0.1472
78	30	100	650000	3750	DFT-s-OFDM 256 QAM	135@67	20.05	19.38	0.0867
78	30	100	650000	3750	DFT-s-OFDM 256 QAM	1@1	19.76	19.09	0.0811
78	30	100	650000	3750	DFT-s-OFDM 256 QAM	1@27 1	19.99	19.32	0.0855
78	30	100	650000	3750	CP-OFDM QPSK	137@68	23.05	22.38	0.1730
78	30	100	650000	3750	CP-OFDM QPSK	1@1	22.77	22.1	0.1622
78	30	100	650000	3750	CP-OFDM QPSK	1@27 1	22.95	22.28	0.1690
78	30	20	647334	3710.01	DFT-s-OFDM PI/2 BPSK	1@1	24.4	23.73	0.2360
78	30	20	647334	3710.01	DFT-s-OFDM QPSK	1@1	24.45	23.78	0.2388
78	30	20	647334	3710.01	DFT-s-OFDM 16 QAM	1@1	23.21	22.54	0.1795
78	30	20	650000	3750	DFT-s-OFDM PI/2 BPSK	1@1	24.51	23.84	0.2421
78	30	20	650000	3750	DFT-s-OFDM QPSK	1@1	24.54	23.87	0.2438
78	30	20	650000	3750	DFT-s-OFDM 16 QAM	1@1	23.32	22.65	0.1841
78	30	20	652666	3789.99	DFT-s-OFDM PI/2 BPSK	1@1	24.54	23.87	0.2438
78	30	20	652666	3789.99	DFT-s-OFDM QPSK	1@1	24.53	23.86	0.2432
78	30	20	652666	3789.99	DFT-s-OFDM 16 QAM	1@1	23.34	22.67	0.1849
78	30	30	647668	3715.02	DFT-s-OFDM PI/2 BPSK	1@1	24.29	23.62	0.2301
78	30	30	647668	3715.02	DFT-s-OFDM	1@1	24.4	23.73	0.2360

QPSK										
78	30	30	647668	3715.02	DFT-s-OFDM 16 QAM	1@1	23.09	22.42	0.1746	
78	30	30	650000	3750	DFT-s-OFDM PI/2 BPSK	1@1	24.43	23.76	0.2377	
78	30	30	650000	3750	DFT-s-OFDM QPSK	1@1	24.53	23.86	0.2432	
78	30	30	650000	3750	DFT-s-OFDM 16 QAM	1@1	23.21	22.54	0.1795	
78	30	30	652332	3784.98	DFT-s-OFDM PI/2 BPSK	1@1	24.41	23.74	0.2366	
78	30	30	652332	3784.98	DFT-s-OFDM QPSK	1@1	24.48	23.81	0.2404	
78	30	30	652332	3784.98	DFT-s-OFDM 16 QAM	1@1	23.23	22.56	0.1803	
78	30	40	648000	3720	DFT-s-OFDM PI/2 BPSK	1@1	24.32	23.65	0.2317	
78	30	40	648000	3720	DFT-s-OFDM QPSK	1@1	24.3	23.63	0.2307	
78	30	40	648000	3720	DFT-s-OFDM 16 QAM	1@1	23.14	22.47	0.1766	
78	30	40	650000	3750	DFT-s-OFDM PI/2 BPSK	1@1	24.38	23.71	0.2350	
78	30	40	650000	3750	DFT-s-OFDM QPSK	1@1	24.45	23.78	0.2388	
78	30	40	650000	3750	DFT-s-OFDM 16 QAM	1@1	23.12	22.45	0.1758	
78	30	40	652000	3780	DFT-s-OFDM PI/2 BPSK	1@1	24.46	23.79	0.2393	
78	30	40	652000	3780	DFT-s-OFDM QPSK	1@1	24.56	23.89	0.2449	
78	30	40	652000	3780	DFT-s-OFDM 16 QAM	1@1	23.27	22.6	0.1820	
78	30	50	648334	3725.01	DFT-s-OFDM PI/2 BPSK	1@1	24.37	23.7	0.2344	
78	30	50	648334	3725.01	DFT-s-OFDM QPSK	1@1	24.42	23.75	0.2371	
78	30	50	648334	3725.01	DFT-s-OFDM 16 QAM	1@1	23.11	22.44	0.1754	
78	30	50	650000	3750	DFT-s-OFDM PI/2 BPSK	1@1	24.37	23.7	0.2344	
78	30	50	650000	3750	DFT-s-OFDM QPSK	1@1	24.4	23.73	0.2360	
78	30	50	650000	3750	DFT-s-OFDM 16 QAM	1@1	23.16	22.49	0.1774	
78	30	50	651666	3774.99	DFT-s-OFDM PI/2 BPSK	1@1	24.43	23.76	0.2377	
78	30	50	651666	3774.99	DFT-s-OFDM QPSK	1@1	24.44	23.77	0.2382	
78	30	50	651666	3774.99	DFT-s-OFDM 16 QAM	1@1	23.1	22.43	0.1750	
78	30	60	648668	3730.02	DFT-s-OFDM PI/2 BPSK	1@1	24.28	23.61	0.2296	
78	30	60	648668	3730.02	DFT-s-OFDM QPSK	1@1	24.36	23.69	0.2339	
78	30	60	648668	3730.02	DFT-s-OFDM 16 QAM	1@1	23.03	22.36	0.1722	
78	30	60	650000	3750	DFT-s-OFDM PI/2 BPSK	1@1	24.36	23.69	0.2339	
78	30	60	650000	3750	DFT-s-OFDM QPSK	1@1	24.4	23.73	0.2360	
78	30	60	650000	3750	DFT-s-OFDM 16 QAM	1@1	23.09	22.42	0.1746	
78	30	60	651332	3769.98	DFT-s-OFDM PI/2 BPSK	1@1	24.37	23.7	0.2344	
78	30	60	651332	3769.98	DFT-s-OFDM QPSK	1@1	24.37	23.7	0.2344	

78	30	60	651332	3769.98	DFT-s-OFDM 16 QAM	1@1	23.19	22.52	0.1786
78	30	80	649334	3740.01	DFT-s-OFDM PI/2 BPSK	1@1	24.22	23.55	0.2265
78	30	80	649334	3740.01	DFT-s-OFDM QPSK	1@1	24.31	23.64	0.2312
78	30	80	649334	3740.01	DFT-s-OFDM 16 QAM	1@1	22.91	22.24	0.1675
78	30	80	650000	3750	DFT-s-OFDM PI/2 BPSK	1@1	24.3	23.63	0.2307
78	30	80	650000	3750	DFT-s-OFDM QPSK	1@1	24.39	23.72	0.2355
78	30	80	650000	3750	DFT-s-OFDM 16 QAM	1@1	22.97	22.3	0.1698
78	30	80	650666	3759.99	DFT-s-OFDM PI/2 BPSK	1@1	24.29	23.62	0.2301
78	30	80	650666	3759.99	DFT-s-OFDM QPSK	1@1	24.4	23.73	0.2360
78	30	80	650666	3759.99	DFT-s-OFDM 16 QAM	1@1	23.02	22.35	0.1718
78	30	90	649668	3745.02	DFT-s-OFDM PI/2 BPSK	1@1	24.26	23.59	0.2286
78	30	90	649668	3745.02	DFT-s-OFDM QPSK	1@1	24.28	23.61	0.2296
78	30	90	649668	3745.02	DFT-s-OFDM 16 QAM	1@1	22.89	22.22	0.1667
78	30	90	650000	3750	DFT-s-OFDM PI/2 BPSK	1@1	24.26	23.59	0.2286
78	30	90	650000	3750	DFT-s-OFDM QPSK	1@1	24.36	23.69	0.2339
78	30	90	650000	3750	DFT-s-OFDM 16 QAM	1@1	22.91	22.24	0.1675
78	30	90	650332	3754.98	DFT-s-OFDM PI/2 BPSK	1@1	24.2	23.53	0.2254
78	30	90	650332	3754.98	DFT-s-OFDM QPSK	1@1	24.31	23.64	0.2312
78	30	90	650332	3754.98	DFT-s-OFDM 16 QAM	1@1	22.95	22.28	0.1690

Frequency Stability

NR Band	SCS (kHz)	Bandwidth (MHz)	Arfcn	Freq (MHz)	Modulation	RB	Deviation (ppm)	Verdict	Environment
78	30	20	650000	3750.0	DFT-s-OFDM QPS	50@0	0.0025	PASS	NV
78	30	20	650000	3750.0	DFT-s-OFDM QPSK	50@0	0.0016	PASS	LV
78	30	20	650000	3750.0	DFT-s-OFDM QPSK	50@0	-0.0014	PASS	HV
78	30	20	650000	3750.0	DFT-s-OFDM QPSK	50@0	0.0022	PASS	-30°C
78	30	20	650000	3750.0	DFT-s-OFDM QPSK	50@0	0.0024	PASS	-20°C
78	30	20	650000	3750.0	DFT-s-OFDM QPSK	50@0	-0.0017	PASS	-10°C
78	30	20	650000	3750.0	DFT-s-OFDM QPSK	50@0	0.0021	PASS	0°C
78	30	20	650000	3750.0	DFT-s-OFDM QPSK	50@0	0.0033	PASS	10°C
78	30	20	650000	3750.0	DFT-s-OFDM QPSK	50@0	0.0024	PASS	20°C
78	30	20	650000	3750.0	DFT-s-OFDM QPSK	50@0	-0.0021	PASS	30°C
78	30	20	650000	3750.0	DFT-s-OFDM QPSK	50@0	0.0027	PASS	40°C
78	30	20	650000	3750.0	DFT-s-OFDM QPSK	50@0	0.0031	PASS	50°C

Peak to Average Ratio

NR Band	SCS (kHz)	Bandwidth (MHz)	Arfcn	Freq (MHz)	Modulation	RB	Result (dB)	Limit (dB)	Verdict
78	30	20	650000	3750.0	DFT-s-OFDM PI/2 BPSK	50@0	7.25	13	PASS
78	30	20	650000	3750.0	DFT-s-OFDM PI/2 BPSK	1@0	7.23	13	PASS
78	30	20	650000	3750.0	DFT-s-OFDM QPSK	50@0	8.34	13	PASS
78	30	20	650000	3750.0	DFT-s-OFDM QPSK	1@0	7.81	13	PASS

N78(20M)_DFT-s-OFDM_PI_2-BPSK_Outer_Full_Mid_CH

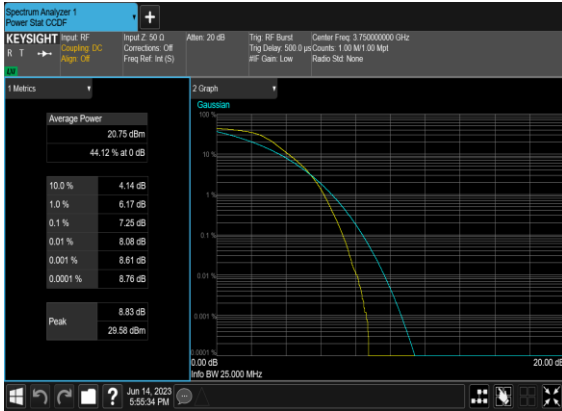

N78(20M)_DFT-s-OFDM_PI_2-BPSK_Edge_1RB_Left_Mid_CH

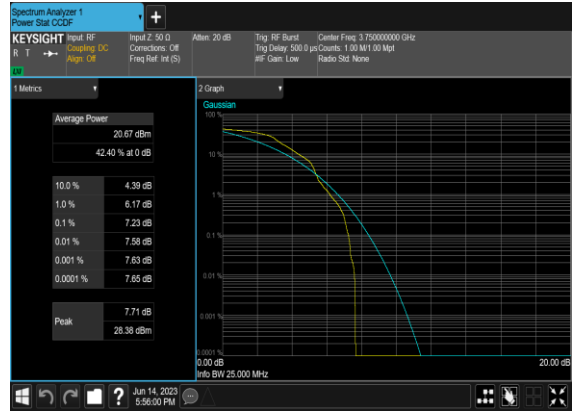

N78(20M)_DFT-s-OFDM_QPSK_Outer_Full_Mid_CH



N78(20M)_DFT-s-OFDM_QPSK_Edge_1RB_Left_Mid_CH



Occupied Bandwidth

NR Band	SCS (kHz)	Bandwidth (MHz)	Arfcn	Freq (MHz)	Modulation	RB	OBW (MHz)	26dB BW (MHz)
78	30	20	650000	3750.0	CP-OFDM QPSK	51@0	18.218	19.05
78	30	20	650000	3750.0	CP-OFDM 16 QAM	51@0	18.161	19.19
78	30	20	650000	3750.0	CP-OFDM 64 QAM	51@0	18.172	18.95
78	30	20	650000	3750.0	CP-OFDM 256 QAM	51@0	18.161	18.87

N78(20M)_CP-OFDM_QPSK_Outer_Full_Mid_CH

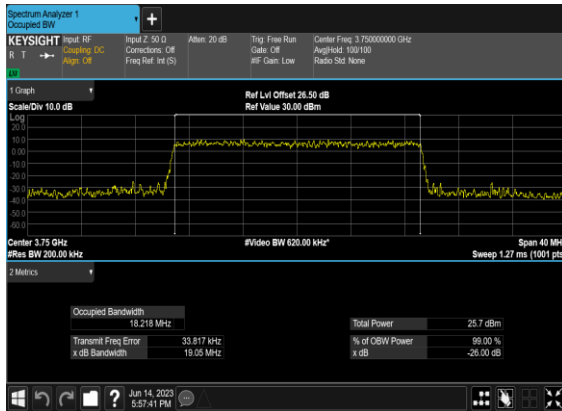

N78(20M)_CP-OFDM_16QAM_Outer_Full_Mid_CH

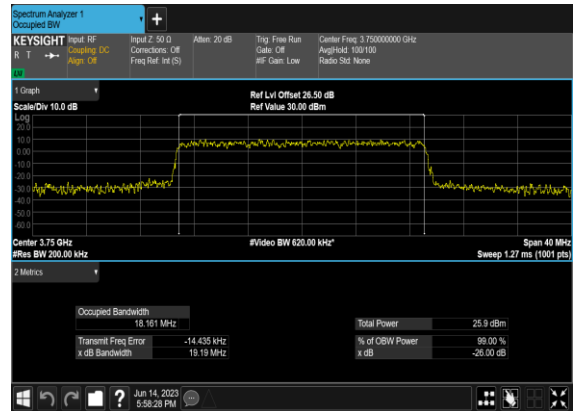

N78(20M)_CP-OFDM_64QAM_Outer_Full_Mid_CH

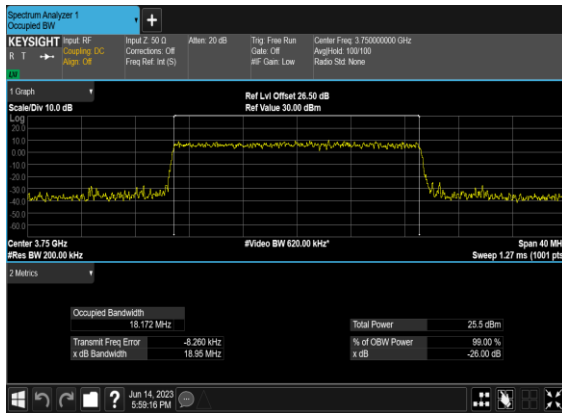

N78(20M)_CP-OFDM_256QAM_Outer_Full_Mid_CH

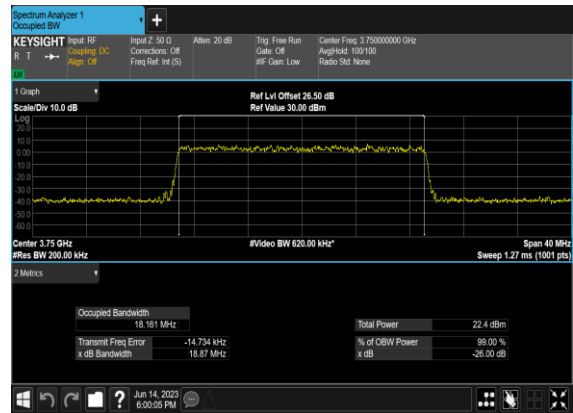

Conducted Spurious Emissions

NR Band	SCS (kHz)	Bandwidth (MHz)	Arfcn	Freq (MHz)	Modulation	RB	Result	Verdict
78	30	20	647334	3710.01	DFT-s-OFDM BPSK	1@0	see graph	---
78	30	20	647334	3710.01	DFT-s-OFDM BPSK	1@0	see graph	PASS
78	30	20	647334	3710.01	DFT-s-OFDM BPSK	1@0	see graph	PASS
78	30	20	647334	3710.01	DFT-s-OFDM QPSK	1@0	see graph	---
78	30	20	647334	3710.01	DFT-s-OFDM QPSK	1@0	see graph	PASS
78	30	20	647334	3710.01	DFT-s-OFDM QPSK	1@0	see graph	PASS
78	30	20	650000	3710.01	DFT-s-OFDM BPSK	1@0	see graph	---
78	30	20	650000	3710.01	DFT-s-OFDM BPSK	1@0	see graph	PASS
78	30	20	650000	3710.01	DFT-s-OFDM BPSK	1@0	see graph	PASS
78	30	20	650000	3750.0	DFT-s-OFDM QPSK	1@0	see graph	---
78	30	20	650000	3750.0	DFT-s-OFDM QPSK	1@0	see graph	PASS
78	30	20	650000	3750.0	DFT-s-OFDM QPSK	1@0	see graph	PASS
78	30	20	652666	3789.99	DFT-s-OFDM BPSK	1@0	see graph	---
78	30	20	652666	3789.99	DFT-s-OFDM BPSK	1@0	see graph	PASS
78	30	20	652666	3789.99	DFT-s-OFDM BPSK	1@0	see graph	PASS
78	30	20	652666	3789.99	DFT-s-OFDM QPSK	1@0	see graph	---
78	30	20	652666	3789.99	DFT-s-OFDM QPSK	1@0	see graph	PASS
78	30	20	652666	3789.99	DFT-s-OFDM QPSK	1@0	see graph	PASS

N78(20M)_DFT-s-OFDM_BPSK_Edge_1RB_Left_Low_CH

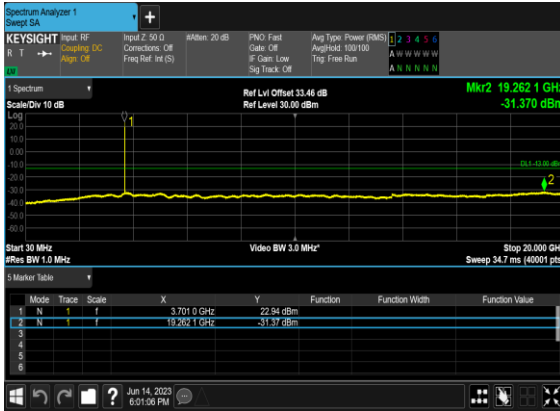

N78(20M)_DFT-s-OFDM_BPSK_Edge_1RB_Left_Low_CH

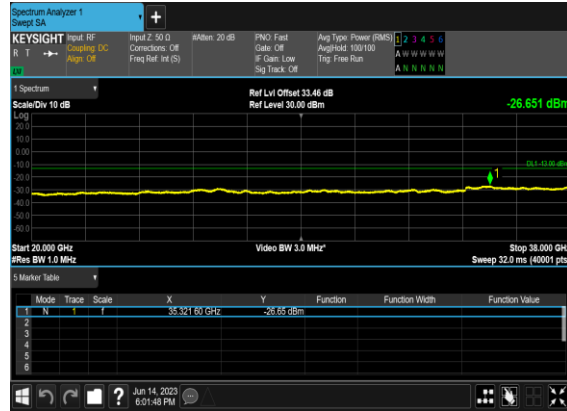

N78(20M)_DFT-s-OFDM_QPSK_Edge_1RB_Left_Low_CH

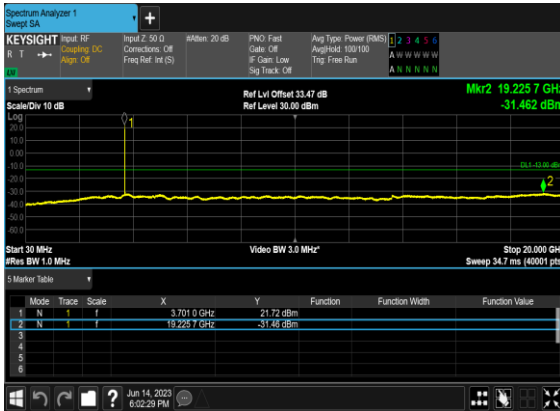

N78(20M)_DFT-s-OFDM_QPSK_Edge_1RB_Left_Low_CH

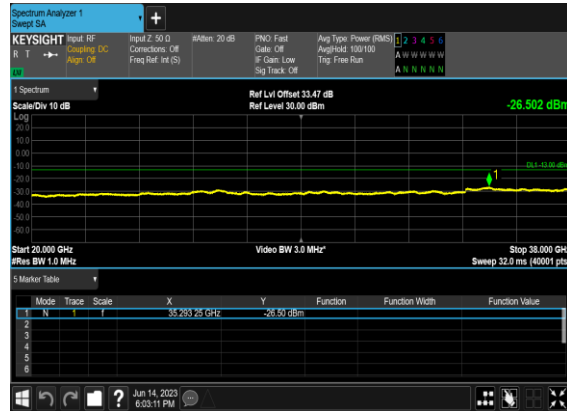

N78(20M)_DFT-s-OFDM_BPSK_Edge_1RB_Left_Mid_CH

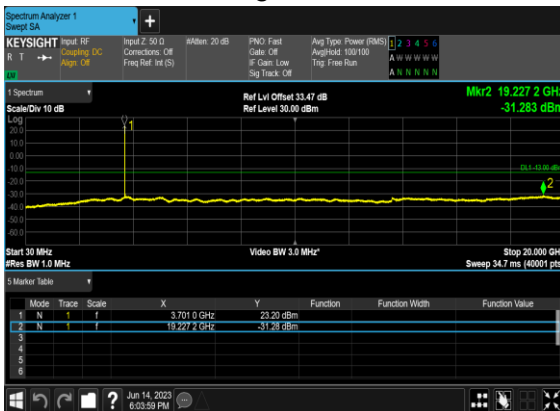

N78(20M)_DFT-s-OFDM_BPSK_Edge_1RB_Left_Mid_CH

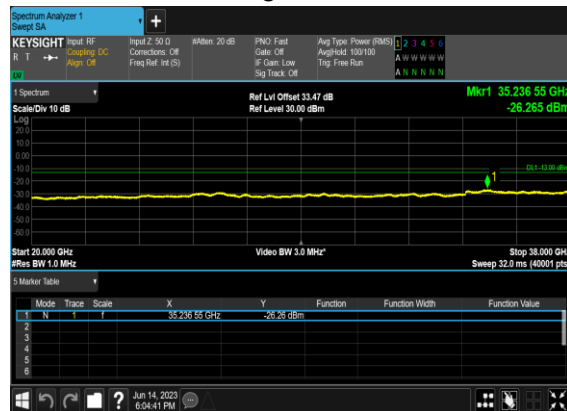

N78(20M)_DFT-s-OFDM_QPSK_Edge_1RB_Left_Mid_CH

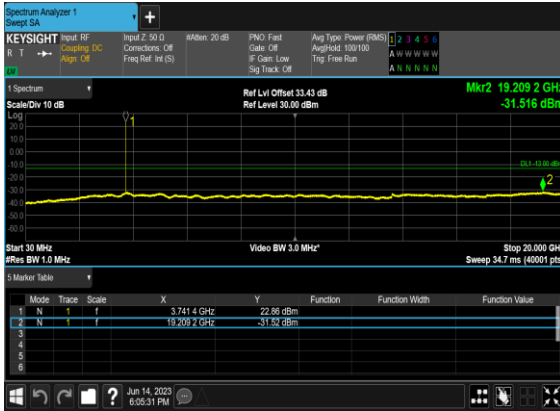

N78(20M)_DFT-s-OFDM_QPSK_Edge_1RB_Left_Mid_CH

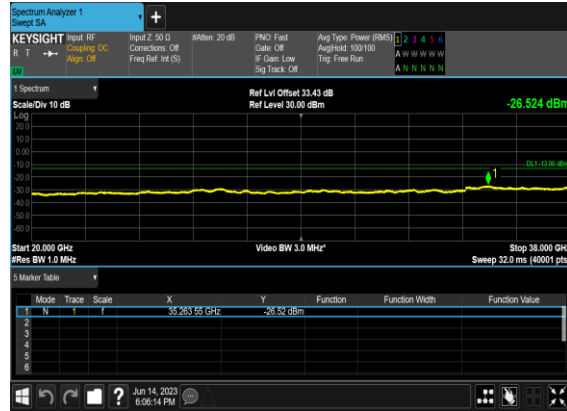

N78(20M)_DFT-s-OFDM_BPSK_Edge_1RB_Left_High_CH

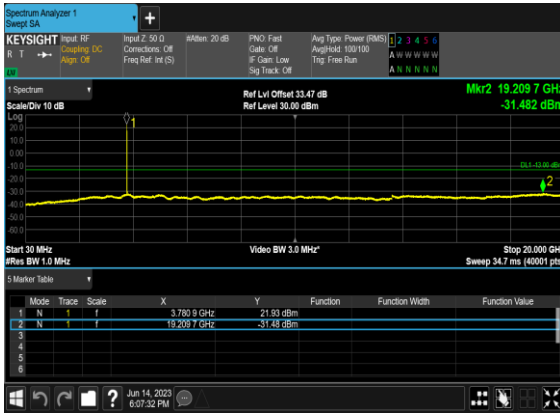

N78(20M)_DFT-s-OFDM_BPSK_Edge_1RB_Left_High_CH

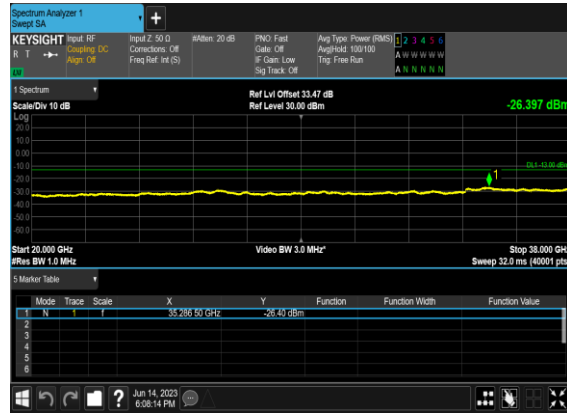

N78(20M)_DFT-s-OFDM_QPSK_Edge_1RB_Left_High_CH

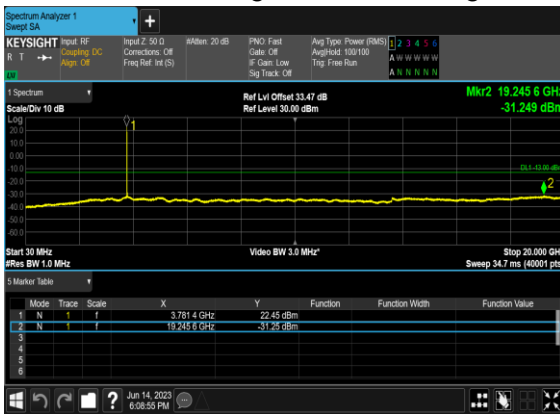

N78(20M)_DFT-s-OFDM_QPSK_Edge_1RB_Left_High_CH

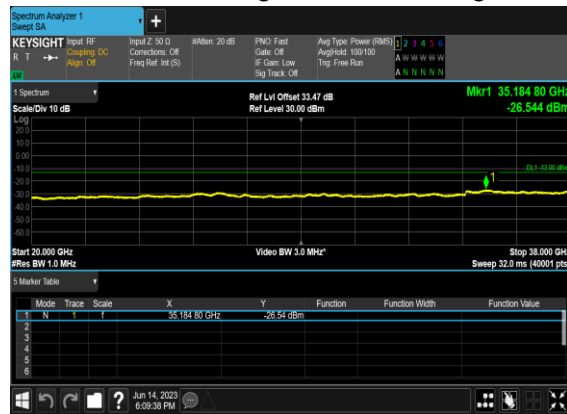

Conducted Band Edge

NR Band	SCS (kHz)	Bandwidth (MHz)	Arfcn	Freq (MHz)	Modulation	RB	Result	Verdict
78	30	20	647334	3710.01	DFT-s-OFDM BPSK	1@0	see graph	PASS
78	30	20	647334	3710.01	DFT-s-OFDM QPSK	1@0	see graph	PASS
78	30	20	647334	3710.01	DFT-s-OFDM BPSK	50@0	see graph	PASS
78	30	20	647334	3710.01	DFT-s-OFDM QPSK	50@0	see graph	PASS
78	30	20	652666	3789.99	DFT-s-OFDM BPSK	1@50	see graph	PASS
78	30	20	652666	3789.99	DFT-s-OFDM QPSK	1@50	see graph	PASS
78	30	20	652666	3789.99	DFT-s-OFDM BPSK	50@0	see graph	PASS
78	30	20	652666	3789.99	DFT-s-OFDM QPSK	50@0	see graph	PASS

N78(20M)_DFT-s-OFDM_BPSK_Edge_1RB_Left_Low_CH

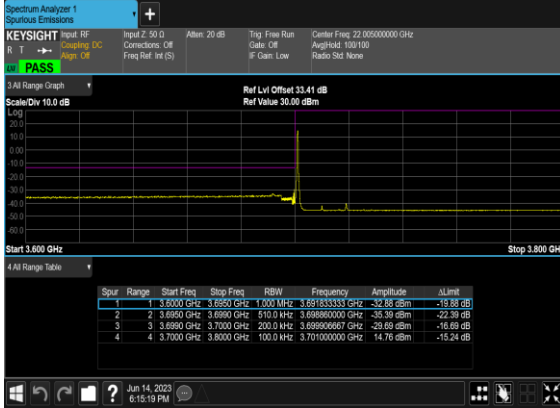

N78(20M)_DFT-s-OFDM_QPSK_Edge_1RB_Left_Low_CH

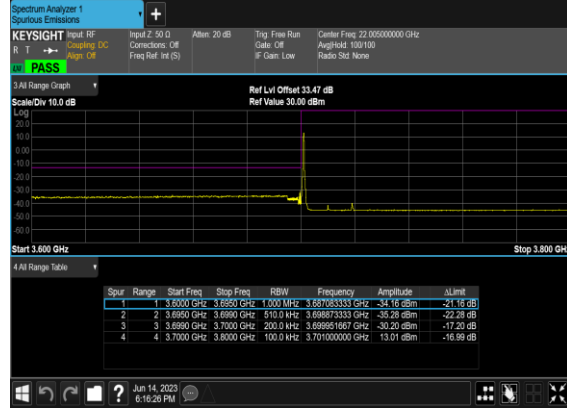

N78(20M)_DFT-s-OFDM_BPSK_Outer_Full_Low_CH

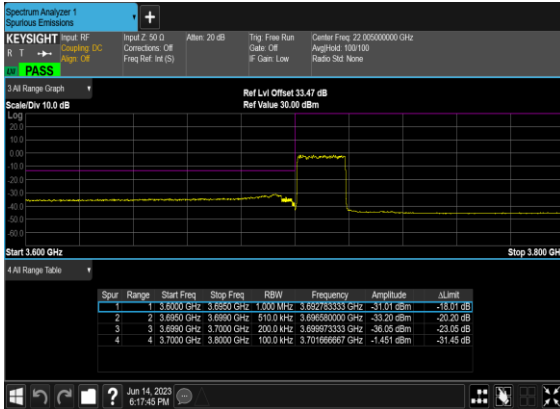

N78(20M)_DFT-s-OFDM_QPSK_Outer_Full_Low_CH

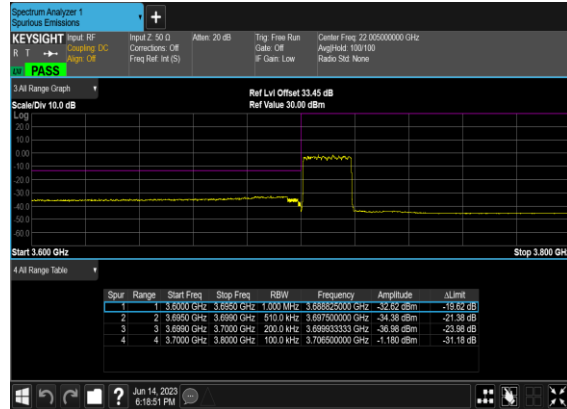

N78(20M)_DFT-s-OFDM_BPSK_Edge_1RB_Right_High_CH

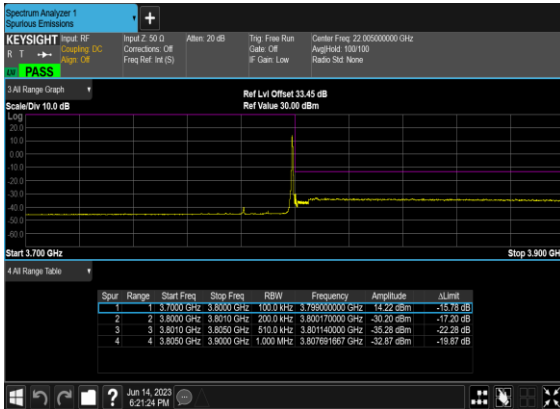

N78(20M)_DFT-s-OFDM_QPSK_Edge_1RB_Right_High_CH

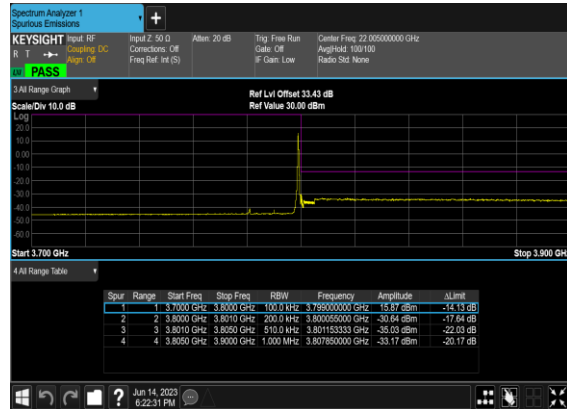

N78(20M)_DFT-s-OFDM_BPSK_Outer_Full_High_CH



N78(20M)_DFT-s-OFDM_QPSK_Outer_Full_High_CH

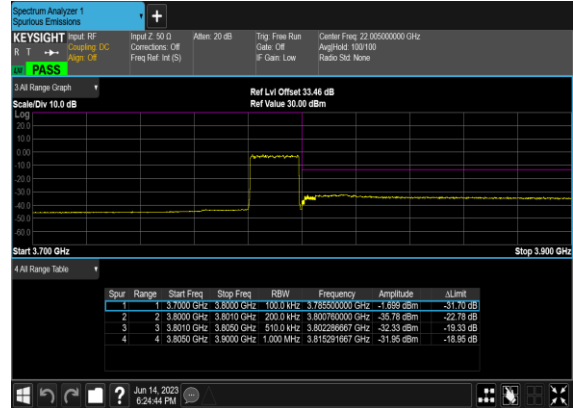



Appendix B. Test Results of Radiated Test

Radiated Spurious Emission

Test Engineer :	Moon Liu	Temperature :	23~25°C
		Relative Humidity :	41~42%

RSE pre-scanned harmonic for different antennas, choose the worst antenna perform final test and record in the report.

n77 SA / NR 100MHz / QPSK / ANT5								
Channel	Frequency (MHz)	EIRP (dBm)	Limit (dBm)	Over Limit (dB)	S.G. Power (dBm)	TX Cable loss (dB)	TX Antenna Gain (dBi)	Polarization (H/V)
Middle	7584	-62.05	-13	-49.05	-72.26	3.03	13.24	H
	11388	-56.85	-13	-43.85	-66.30	3.56	13.01	H
	15180	-58.69	-13	-45.69	-68.21	3.92	13.44	H
	7584	-61.63	-13	-48.63	-71.84	3.03	13.24	V
	11388	-55.91	-13	-42.91	-65.36	3.56	13.01	V
	15180	-58.44	-13	-45.44	-67.96	3.92	13.44	V

Remark: Spurious emissions within 30-1000MHz were found more than 20dB below limit line.

n78 SA / NR 100MHz / QPSK / ANT5								
Channel	Frequency (MHz)	EIRP (dBm)	Limit (dBm)	Over Limit (dB)	S.G. Power (dBm)	TX Cable loss (dB)	TX Antenna Gain (dBi)	Polarization (H/V)
Middle	7416	-61.35	-13	-48.35	-71.56	3.03	13.24	H
	11112	-57.02	-13	-44.02	-66.47	3.56	13.01	H
	14820	-59.45	-13	-46.45	-68.97	3.92	13.44	H
	7416	-61.43	-13	-48.43	-71.64	3.03	13.24	V
	11112	-57.05	-13	-44.05	-66.50	3.56	13.01	V
	14820	-59.36	-13	-46.36	-68.88	3.92	13.44	V

Remark: Spurious emissions within 30-1000MHz were found more than 20dB below limit line.