



FCC RF Test Report

APPLICANT : Xiaomi Communications Co., Ltd.
EQUIPMENT : Mobile Phone
BRAND NAME : Xiaomi
MODEL NAME : 23078PND5G
FCC ID : 2AFZZND5G
STANDARD : 47 CFR Part 2, Part 27 Subpart Q
CLASSIFICATION : PCS Licensed Transmitter Held to Ear (PCE)
TEST DATE(S) : May 23, 2023 ~ May 31, 2023

We, Sporton International Inc. (ShenZhen), would like to declare that the tested sample has been evaluated in accordance with the procedures given in ANSI C63.26-2015 and shown compliance with the applicable technical standards.

The test results in this report apply exclusively to the tested model / sample. Without written approval of Sporton International Inc. (ShenZhen), the test report shall not be reproduced except in full.

Jason Jia



Approved by: Jason Jia

Sporton International Inc. (ShenZhen)

1/F, 2/F, Bldg 5, Shiling Industrial Zone, Xinwei Village, Xili, Nanshan, Shenzhen, 518055

People's Republic of China



TABLE OF CONTENTS

REVISION HISTORY..... 3
SUMMARY OF TEST RESULT 4
1 GENERAL DESCRIPTION 5
1.1 Applicant 5
1.2 Manufacturer 5
1.3 Product Feature of Equipment Under Test 5
1.4 Product Specification of Equipment Under Test 5
1.5 Modification of EUT 6
1.6 Maximum EIRP Power and Emission Designator 6
1.7 Testing Site 6
1.8 Test Software 6
1.9 Applied Standards 7
2 TEST CONFIGURATION OF EQUIPMENT UNDER TEST 8
2.1 Test Mode 8
2.2 Connection Diagram of Test System 9
2.3 Support Unit used in test configuration and system 9
2.4 Measurement Results Explanation Example 9
2.5 Frequency List of Low/Middle/High Channels 10
3 CONDUCTED TEST ITEMS 11
3.1 Measuring Instruments 11
3.2 Test Setup 11
3.3 Test Result of Conducted Test 11
3.4 Conducted Output Power Measurement 12
3.5 Peak-to-Average Ratio 13
3.6 EIRP 14
3.7 Occupied Bandwidth 15
3.8 Conducted Band Edge Measurement 16
3.9 Conducted Spurious Emission Measurement 17
3.10 Frequency Stability Measurement 18
4 RADIATED TEST ITEMS 19
4.1 Measuring Instruments 19
4.2 Test Setup 19
4.3 Test Result of Radiated Test 20
4.4 Radiated Spurious Emission Measurement 21
5 LIST OF MEASURING EQUIPMENT 22
6 MEASUREMENT UNCERTAINTY 23
APPENDIX A. TEST RESULTS OF CONDUCTED TEST
APPENDIX B. TEST RESULTS OF RADIATED TEST
APPENDIX C. TEST SETUP PHOTOGRAPHS



SUMMARY OF TEST RESULT

| Report Section | FCC Rule | Description | Limit | Result | Remark |
|----------------|--------------------------|--|-------------------|-------------|---|
| 3.4 | §2.1046 | Conducted Output Power | — | Report Only | - |
| 3.5 | §27.50 (k)(4) | Peak-to-Average Ratio | <13dB | PASS | |
| 3.6 | §27.50 (k)(3) | EIRP | EIRP < 1W (30dBm) | PASS | - |
| 3.7 | §2.1049 | Occupied Bandwidth | — | Report Only | - |
| 3.8 | §2.1051 §27.53 (n)(2) | Conducted Band Edge Measurement | -13dBm/MHz | PASS | - |
| 3.9 | §2.1051 §27.53 (n)(2) | Conducted Spurious Emission | -13dBm/MHz | PASS | - |
| 3.10 | §2.1055 §27.54 | Frequency Stability Temperature & Voltage | Within the band | PASS | - |
| 4.4 | §2.1053 §27.53 (n)(2) | Radiated Spurious Emission | -13dBm/MHz | PASS | Under limit 32.63 dB at 13964.00 MHz |

Conformity Assessment Condition:

- The test results (PASS/FAIL) with all measurement uncertainty excluded are presented against the regulation limits or in accordance with the requirements stipulated by the applicant/manufacturer who shall bear all the risks of non-compliance that may potentially occur if measurement uncertainty is taken into account.
- The measurement uncertainty please refer to each test result in the section "Measurement Uncertainty"

Disclaimer:

The product specifications of the EUT presented in the test report that may affect the test assessments are declared by the manufacturer who shall take full responsibility for the authenticity.

1 General Description

1.1 Applicant

Xiaomi Communications Co., Ltd.

#019, 9th Floor, Building 6, 33 Xi'erqi Middle Road, Haidian District, Beijing, China, 100085

1.2 Manufacturer

Xiaomi Communications Co., Ltd.

#019, 9th Floor, Building 6, 33 Xi'erqi Middle Road, Haidian District, Beijing, China, 100085

1.3 Product Feature of Equipment Under Test

| Product Feature | |
|-------------------|--|
| Equipment | Mobile Phone |
| Brand Name | Xiaomi |
| Model Name | 23078PND5G |
| FCC ID | 2AFZZND5G |
| IMEI Code | Conducted: 861585060039540/861585060039557 Radiation: 861585060042627/861585060042635 |
| HW Version | P2.0 |
| SW Version | MIUI 14 |
| EUT Stage | Identical Prototype |

1.4 Product Specification of Equipment Under Test

| Product Feature | |
|--|--|
| Tx/Rx Frequency | LTE Band 42: 3450 MHz ~ 3550 MHz |
| Bandwidth | 5MHz / 10MHz / 15MHz / 20MHz |
| Maximum Output Power to Antenna | <Ant. 1> LTE Band 42 : 23.46 dBm <Ant. 5> LTE Band 42 : 25.05 dBm <Ant. 6> LTE Band 42 : 24.77 dBm <Ant. 7> LTE Band 42 : 23.55 dBm |
| Antenna Gain | <Ant.1> LTE Band 42 : -7.5 dBi <Ant.5> LTE Band 42 : -0.9 dBi <Ant.6> LTE Band 42 : -1.21 dBi <Ant.7> LTE Band 42 : -6.1 dBi |
| Type of Modulation | QPSK / 16QAM / 64QAM / 256QAM |

Note: The maximum EIRP is calculated from maximum Output power and antenna gain, only the maximum EIRP of Ant 5 for LTE Band 42 is shown in the report.

1.5 Modification of EUT

No modifications are made to the EUT during all test items.

1.6 Maximum EIRP Power and Emission Designator

| LTE Band 42 | | QPSK | | 16QAM/64QAM/256QAM | |
|-------------|-----------------------|-----------------|------------------------------|--------------------|------------------------------|
| BW (MHz) | Frequency Range (MHz) | Maximum EIRP(W) | Emission Designator (99%OBW) | Maximum EIRP(W) | Emission Designator (99%OBW) |
| 20 | 3460 ~ 3540 | 0.2600 | 17M9G7D | 0.1936 | 17M8W7D |

1.7 Testing Site

Sporton International Inc. (ShenZhen) is accredited to ISO/IEC 17025:2017 by American Association for Laboratory Accreditation with Certificate Number 5145.01.

| | | | |
|---------------------------|---|----------------------------|---------------------------------------|
| Test Firm | Sporton International Inc. (ShenZhen) | | |
| Test Site Location | 1/F, 2/F, Bldg 5, Shiling Industrial Zone, Xinwei Village, Xili, Nanshan, Shenzhen, 518055 People's Republic of China TEL: +86-755-86379589 FAX: +86-755-86379595 | | |
| Test Site No. | Sporton Site No. | FCC Designation No. | FCC Test Firm Registration No. |
| | TH01-SZ | CN1256 | 421272 |

| | | | |
|---------------------------|---|----------------------------|---------------------------------------|
| Test Firm | Sporton International Inc. (ShenZhen) | | |
| Test Site Location | 101, 1st Floor, Block B, Building 1, No. 2, Tengfeng 4th Road, Fenghuang Community, Fuyong Street, Baoan District, Shenzhen City Guangdong Province China 518103 TEL: +86-755-33202398 | | |
| Test Site No. | Sporton Site No. | FCC Designation No. | FCC Test Firm Registration No. |
| | 03CH01-SZ | CN1256 | 421272 |

1.8 Test Software

| Item | Site | Manufacturer | Name | Version |
|------|-----------|--------------|------|-------------|
| 1. | 03CH01-SZ | AUDIX | E3 | 6.2009-8-24 |



1.9 Applied Standards

According to the specifications of the manufacturer, the EUT must comply with the requirements of the following standards:

- ♦ 47 CFR Part 2, Part 27 Subpart Q
- ♦ ANSI C63.26-2015
- ♦ FCC KDB 971168 Power Meas License Digital Systems D01 v03r01
- ♦ FCC KDB 412172 D01 Determining ERP and EIRP v01r01
- ♦

Remark:

1. All test items were verified and recorded according to the standards and without any deviation during the test.
2. This EUT has also been tested and complied with the requirements of FCC Part 15, Subpart B, recorded in a separate test report.

2 Test Configuration of Equipment Under Test

2.1 Test Mode

Antenna port conducted and radiated test items listed below are performed according to KDB 971168 D01 Power Meas. License Digital Systems v03r01 with maximum output power.

Radiated measurements are performed by rotating the EUT in three different orthogonal test planes to find the maximum emission.

| Test Cases | Band | Bandwidth (MHz) | Modulation | RB # | Test Channel |
|-----------------------------|-------------|-------------------------------|--------------------------------|--------------------------|--------------|
| | | eg. 5M, 10M, 15M, 20M | eg. QPSK, 16QAM, 64QAM, 256QAM | 1RB, Partial RB, Full RB | L/M/H |
| Max. Output Power | LTE Band 42 | 5M, 10M, 15M, 20M | QPSK, 16QAM, 64QAM, 256QAM | 1RB, Partial RB, Full RB | L, M, H |
| Peak-to-Average Ratio | LTE Band 42 | 20M | QPSK, 16QAM, 64QAM | Full RB | M |
| E.I.R.P | LTE Band 42 | 5M, 10M, 15M, 20M | QPSK, 16QAM, 64QAM, 256QAM | 1RB | L, M, H |
| 26dB and 99% Bandwidth | LTE Band 42 | 20M | QPSK, 16QAM | Full RB | M |
| Conducted Band Edge | LTE Band 42 | 5M, 10M, 15M, 20M | QPSK, 16QAM, 64QAM | 1RB, Full RB | L, H |
| Conducted Spurious Emission | LTE Band 42 | 5M, 10M, 15M, 20M | QPSK | 1RB | L, M, H |
| Frequency Stability | LTE Band 42 | 10M | QPSK | 1RB | M |
| Radiated Spurious Emission | LTE Band 42 | Worst case from maximum power | | | M |

Note:

The device is investigated from 30MHz to 10 times of fundamental signal for radiated spurious emission test under different RB size/offset and modulations in exploratory test. Subsequently, only the worst case emissions are reported.

2.2 Connection Diagram of Test System

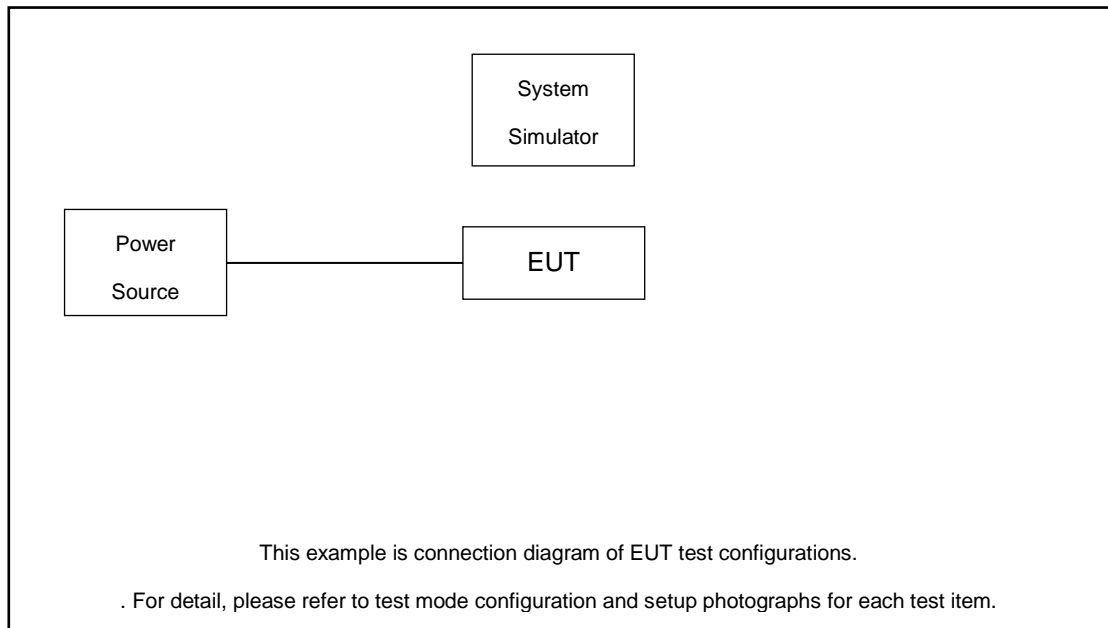

2.3 Support Unit used in test configuration and system

| Item | Equipment | Trade Name | Model No. | FCC ID | Data Cable | Power Cord |
|------|------------------|------------|-------------------|--------|------------|-------------------|
| 1. | Power Supply | GWINSTEK | PSS-2002 | N/A | N/A | Unshielded, 1.8 m |
| 2. | LTE Base Station | Anritsu | MT8820C | N/A | N/A | Unshielded, 1.8 m |
| 3. | Fixture | INTEL | NGFF Card Carrier | N/A | N/A | N/A |

2.4 Measurement Results Explanation Example

For all conducted test items:

The offset level is set in the spectrum analyzer to compensate the RF cable loss and attenuator factor between EUT conducted output port and spectrum analyzer. With the offset compensation, the spectrum analyzer reading level is exactly the EUT RF output level.

The spectrum analyzer offset is derived from RF cable loss and attenuator factor.

Offset = RF cable loss + attenuator factor.

Following shows an offset computation example with cable loss 9.50 dB and 10dB attenuator.

Example :

$$\begin{aligned} \text{Offset(dB)} &= \text{RF cable loss(dB)} + \text{attenuator factor(dB)} \\ &= 9.50 + 10 = 19.50 \text{ (dB)} \end{aligned}$$



2.5 Frequency List of Low/Middle/High Channels

| LTE Band 42 Channel and Frequency List | | | | |
|--|------------------------|--------|--------|---------|
| BW [MHz] | Channel/Frequency(MHz) | Lowest | Middle | Highest |
| 20 | Channel | 42190 | 42590 | 42990 |
| | Frequency | 3460 | 3500 | 3540 |
| 15 | Channel | 42165 | 42590 | 43015 |
| | Frequency | 3457.5 | 3500 | 3542.5 |
| 10 | Channel | 42140 | 42590 | 43040 |
| | Frequency | 3455 | 3500 | 3545 |
| 5 | Channel | 42115 | 42590 | 43065 |
| | Frequency | 3452.5 | 3500 | 3547.5 |

3 Conducted Test Items

3.1 Measuring Instruments

See list of measuring instruments of this test report.

3.2 Test Setup

3.2.1 Conducted Output Power

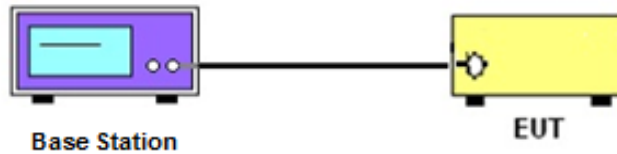

3.2.2 Peak-to-Average Ratio, Occupied / 26dB Bandwidth ,Band-Edge and Conducted Spurious Emission

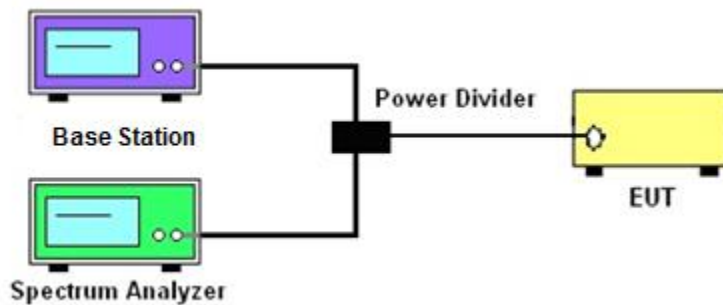

3.2.3 Frequency Stability



3.3 Test Result of Conducted Test

Please refer to Appendix A.

3.4 Conducted Output Power Measurement

3.4.1 Description of the Conducted Output Power Measurement

A base station simulator was used to establish communication with the EUT. Its parameters were set to transmit the maximum power on the EUT. The measured power in the radio frequency on the transmitter output terminals shall be reported.

3.4.2 Test Procedures

1. The testing follows ANSI C63.26 Section 5.2
2. The transmitter output port was connected to the system simulator.
3. Set EUT at maximum power through the system simulator.
4. Select lowest, middle, and highest channels for each band and different modulation.
5. Measure and record the power level from the system simulator.

3.5 Peak-to-Average Ratio

3.5.1 Description of the PAR Measurement

Power Complementary Cumulative Distribution Function (CCDF) curves provide a means for characterizing the power peaks of a digitally modulated signal on a statistical basis. A CCDF curve depicts the probability of the peak signal amplitude exceeding the average power level. Most contemporary measurement instrumentation include the capability to produce CCDF curves for an input signal provided that the instrument's resolution bandwidth can be set wide enough to accommodate the entire input signal bandwidth. In measuring transmissions in this band using an average power technique, the peak-to-average ratio (PAR) of the transmission may not exceed 13 dB.

3.5.2 Test Procedures

1. The testing follows ANSI C63.26 Section 5.2.3.4 (CCDF).
2. The EUT was connected to spectrum and system simulator via a power divider.
3. Set the CCDF (Complementary Cumulative Distribution Function) option in spectrum analyzer.
4. The highest RF powers were measured and recorded the maximum PAPR level associated with a probability of 0.1 %.
5. Record the deviation as Peak to Average Ratio.

3.6 EIRP

3.6.1 Description of EIRP Limit

§ 27.50 (k)(3)

Mobile devices are limited to 1Watt (30 dBm) EIRP. Mobile devices operating in these bands must employ a means for limiting power to the minimum necessary for successful communications

3.6.2 Test Procedures

1. According to KDB 412172 D01 Power Approach,
2. $EIRP = P_T + G_T - L_C$, $ERP = EIRP - 2.15$, where
 P_T = transmitter output power in dBm
 G_T = gain of the transmitting antenna in dBi
 L_C = signal attenuation in the connecting cable between the transmitter and antenna in dB

3.7 Occupied Bandwidth

3.7.1 Description of Occupied Bandwidth Measurement

The occupied bandwidth is the width of a frequency band such that, below the lower and above the upper frequency limits, the mean powers emitted are each equal to a specified percentage 0.5% of the total mean transmitted power.

The 26 dB emission bandwidth is defined as the frequency range between two points, one above and one below the carrier frequency, at which the spectral density of the emission is attenuated 26 dB below the maximum in-band spectral density of the modulated signal. Spectral density (power per unit bandwidth) is to be measured with a detector of resolution bandwidth equal to approximately 1.0% of the emission bandwidth.

3.7.2 Test Procedures

1. The testing follows ANSI C63.26 Section 5.4
2. The EUT was connected to spectrum analyzer and system simulator via a power divider.
3. The spectrum analyzer center frequency is set to the nominal EUT channel center frequency. The span range for the spectrum analyzer shall be between two and five times the anticipated OBW.
4. The nominal resolution bandwidth (RBW) shall be in the range of 1 to 5 % of the anticipated OBW, and the VBW shall be at least 3 times the RBW.
5. Set the detection mode to peak, and the trace mode to max hold.
6. Determine the reference value: Set the EUT to transmit a modulated signal. Allow the trace to stabilize. Set the spectrum analyzer marker to the highest level of the displayed trace.
(this is the reference value)
7. Determine the “-26 dB down amplitude” as equal to (Reference Value – X).
8. Place two markers, one at the lowest and the other at the highest frequency of the envelope of the spectral display such that each marker is at or slightly below the “-X dB down amplitude” determined in step 6. If a marker is below this “-X dB down amplitude” value it shall be placed as close as possible to this value. The OBW is the positive frequency difference between the two markers.
9. Use the 99 % power bandwidth function of the spectrum analyzer and report the measured bandwidth.

3.8 Conducted Band Edge Measurement

3.8.1 Description of Conducted Band Edge Measurement

§ 27.53 (n)(2)

For mobile operations in the 3450-3550 MHz band, the conducted power of any emission outside the licensee's authorized bandwidth shall not exceed -13 dBm/MHz.

Compliance with this paragraph is based on the use of measurement instrumentation employing a resolution bandwidth of 1 megahertz or greater. However, in the 1 megahertz bands immediately outside and adjacent to the licensee's frequency block, a resolution bandwidth of at least one percent of the emission bandwidth of the fundamental emission of the transmitter may be employed, but limited to a maximum of 200 kHz. In the bands between 1 and 5 MHz removed from the licensee's frequency block, the minimum resolution bandwidth for the measurement shall be 500 kHz.

3.8.2 Test Procedures

1. The testing follows ANSI C63.26 section 5.7
2. The EUT was connected to spectrum analyzer and system simulator via a power divider.
3. The band edges of low and high channels for the highest RF powers were measured.
4. Set RBW \geq 1% EBW but limited to a maximum of 200 kHz in the 1MHz band immediately outside and adjacent to the band edge.
5. Beyond the 1 MHz and 5 MHz removed from the band edge, set RBW \geq 500KHz.
6. Beyond the 5 MHz removed from the band edge, set RBW = 1MHz.
7. Set spectrum analyzer with RMS detector.
8. The RF fundamental frequency should be excluded against the limit line in the operating frequency band.
9. Checked that all the results comply with the emission limit line.

3.9 Conducted Spurious Emission Measurement

3.9.1 Description of Conducted Spurious Emission Measurement

The power of any emission outside of the authorized operating frequency ranges shall not exceed -13 dBm/MHz.

It is measured by means of a calibrated spectrum analyzer and scanned from 9 kHz up to a frequency including its 10th harmonic.

3.9.2 Test Procedures

1. The testing follows ANSI C63.26 section 5.7
2. The EUT was connected to spectrum analyzer and system simulator via a power divider.
3. The RF output of EUT was connected to the spectrum analyzer by RF cable and attenuator. The path loss was compensated to the results for each measurement.
4. The middle channel for the highest RF power within the transmitting frequency was measured.
5. The conducted spurious emission for the whole frequency range was taken.
6. Make the measurement with the spectrum analyzer's RBW = 1MHz, VBW = 3MHz.
7. Set spectrum analyzer with RMS detector.
8. Taking the record of maximum spurious emission.
9. The RF fundamental frequency should be excluded against the limit line in the operating frequency band.
10. Checked that all the results comply with the emission limit line.

3.10 Frequency Stability Measurement

3.10.1 Description of Frequency Stability Measurement

The frequency stability shall be measured by variation of ambient temperature and variation of primary supply voltage to ensure that the fundamental emission stays within the authorized frequency block.

3.10.2 Test Procedures for Temperature Variation

1. The testing follows ANSI C63.26 section 5.6.4
2. The EUT was set up in the thermal chamber and connected with the system simulator.
3. With power OFF, the temperature was decreased to -30°C and the EUT was stabilized before testing. Power was applied and the maximum change in frequency was recorded within one minute.
4. With power OFF, the temperature was raised in 10°C step up to 50°C . The EUT was stabilized at each step for at least half an hour. Power was applied and the maximum frequency change was recorded within one minute.

3.10.3 Test Procedures for Voltage Variation

1. The testing follows ANSI C63.26 section 5.6.5.
2. The EUT was placed in a temperature chamber at $20\pm 5^{\circ}\text{C}$ and connected with the system simulator.
3. The power supply voltage to the EUT was varied from 85% to 115% of the nominal value for other than hand carried battery equipment.
4. For hand carried, battery powered equipment, reduce the primary ac or dc supply voltage to the battery operating end point, which shall be specified by the manufacturer.
5. The variation in frequency was measured for the worst case.

4 Radiated Test Items

4.1 Measuring Instruments

See list of measuring instruments of this test report.

4.2 Test Setup

4.2.1 For radiated test below 30MHz

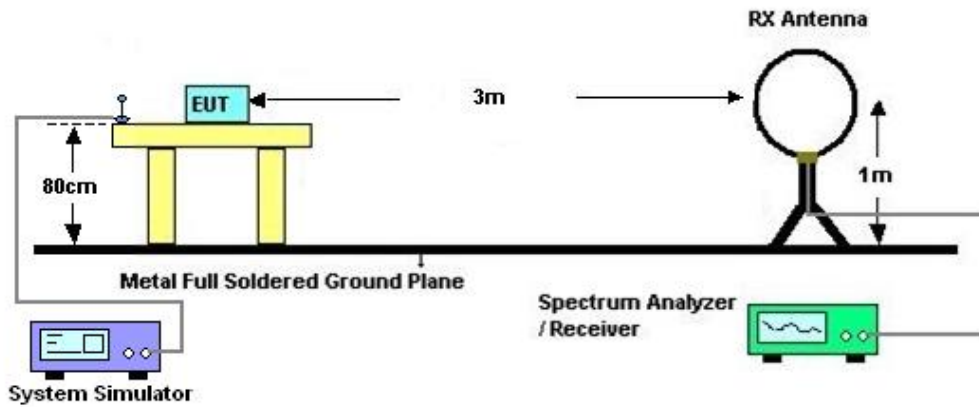

4.2.2 For radiated test from 30MHz to 1GHz

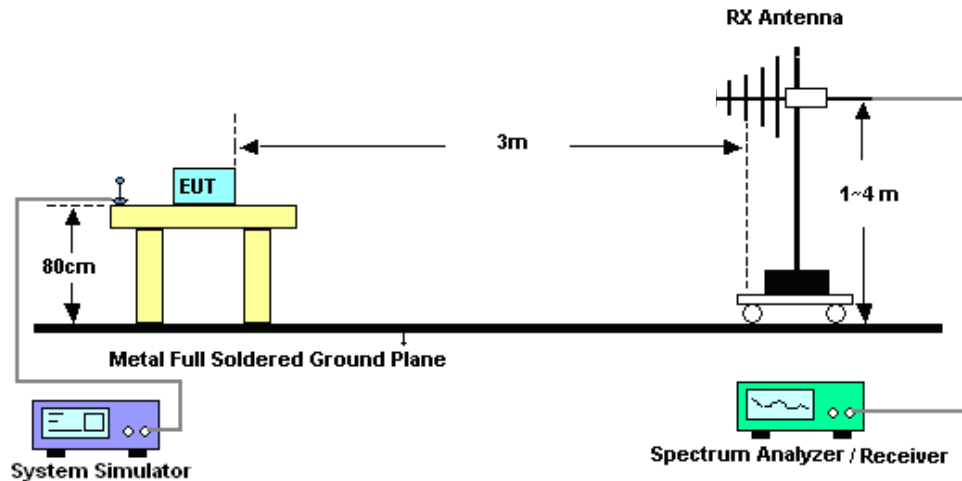

4.2.3 For radiated test above 1GHz



4.3 Test Result of Radiated Test

The low frequency, which started from 9 kHz to 30MHz, was pre-scanned and the result which was 20dB lower than the limit line was not reported.

Please refer to Appendix B.

4.4 Radiated Spurious Emission Measurement

4.4.1 Description of Radiated Spurious Emission

The radiated spurious emission was measured by substitution method according to ANSI/TIA-603-E. The power of any emission outside of the authorized operating frequency ranges shall not exceed -13 dBm/MHz.

The spectrum is scanned from 30 MHz up to a frequency including its 10th harmonic.

4.4.2 Test Procedures

1. The testing follows ANSI C63.26 Section 5.5
2. The EUT was placed on a turntable with 0.8 meter height for frequency below 1GHz and 1.5 meter height for frequency above 1GHz respectively above ground.
3. The EUT was set 3 meters from the receiving antenna mounted on the antenna tower.
4. The table was rotated 360 degrees to determine the position of the highest spurious emission.
5. The height of the receiving antenna is varied between 1m to 4m to search the maximum spurious emission for both horizontal and vertical polarizations.
6. During the measurement, the system simulator parameters were set to force the EUT transmitting at maximum output power.
7. Make the measurement with the spectrum analyzer's RBW = 1MHz, VBW = 3MHz, taking the record of maximum spurious emission.
8. A horn antenna was substituted in place of the EUT and was driven by a signal generator.
9. Tune the output power of signal generator to the same emission level with EUT maximum spurious emission.
$$\text{EIRP (dBm)} = \text{S.G. Power} - \text{Tx Cable Loss} + \text{Tx Antenna Gain}$$
$$\text{ERP (dBm)} = \text{EIRP} - 2.15$$
10. The RF fundamental frequency should be excluded against the limit line in the operating frequency band.



5 List of Measuring Equipment

| Instrument | Manufacturer | Model No. | Serial No. | Characteristics | Calibration Date | Test Date | Due Date | Remark |
|---------------------------|------------------------------|----------------------------------|--------------------|-----------------|------------------|--------------|---------------|-----------------------|
| Spectrum Analyzer | R&S | FSV40 | 101078 | 10Hz~40GHz | Apr. 06, 2023 | May 31, 2023 | Apr. 05, 2024 | Conducted (TH01-SZ) |
| Power Divider | TOJOIN | PS-2SM-04 265 | 60.06.020.007 7 | 0.4GHz~26.5GHz | Dec. 25, 2022 | May 31, 2023 | Dec. 24, 2023 | Conducted (TH01-SZ) |
| Thermal Chamber | Ten Billion Hongzhangroup | LP-150U | H2014081803 | -40~+150°C | Jul. 07, 2022 | May 31, 2023 | Jul. 06, 2023 | Conducted (TH01-SZ) |
| EMI Test Receiver&SA | Agilent | N9038A | MY52260185 | 20Hz~26.5GHz | Dec. 26, 2022 | May 23, 2023 | Dec. 25, 2023 | Radiation (03CH01-SZ) |
| EXA Spectrum Analyzer | KEYSIGHT | N9010A | MY55150213 | 10Hz~44GHz | Jul. 07, 2022 | May 23, 2023 | Jul. 06, 2023 | Radiation (03CH01-SZ) |
| Loop Antenna | R&S | HFH2-Z2 | 100354 | 9kHz~30MHz | Jul. 28, 2022 | May 23, 2023 | Jul. 27, 2024 | Radiation (03CH01-SZ) |
| Bilog Antenna | TeseQ | CBL6112D | 35407 | 30MHz-2GHz | Sep. 28, 2021 | May 23, 2023 | Sep. 27, 2023 | Radiation (03CH01-SZ) |
| Double Ridge Horn Antenna | ETS-Lindgren | 3117 | 00119436 | 1GHz~18GHz | Jul. 07, 2022 | May 23, 2023 | Jul. 06, 2023 | Radiation (03CH01-SZ) |
| SHF-EHF Horn | com-power | AH-840 | 101071 | 18Ghz-40GHz | Apr. 08,2023 | May 23, 2023 | Apr. 07,2024 | Radiation (03CH01-SZ) |
| LF Amplifier | Burgeon | BPA-530 | 102209 | 0.01~3000Mhz | Apr. 04, 2023 | May 23, 2023 | Apr. 03, 2024 | Radiation (03CH01-SZ) |
| HF Amplifier | MITEQ | AMF-7D-00 101800-30-1 0P-R | 1943528 | 1GHz~18GHz | Oct. 19, 2022 | May 23, 2023 | Oct. 18, 2023 | Radiation (03CH01-SZ) |
| HF Amplifier | KEYSIGHT | 83017A | MY53270105 | 0.5GHz~26.5Ghz | Oct. 19, 2022 | May 23, 2023 | Oct. 18, 2023 | Radiation (03CH01-SZ) |
| HF Amplifier | MITEQ | TTA1840-35 -HG | 1871923 | 18GHz~40GHz | Jul. 06, 2022 | May 23, 2023 | Jul. 05, 2023 | Radiation (03CH01-SZ) |
| AC Power Source | Chroma | 61601 | 61601000198 5 | N/A | Nov. 10, 2022 | May 23, 2023 | Nov. 09, 2023 | Radiation (03CH01-SZ) |
| Turn Table | EM | EM1000 | N/A | 0~360 degree | NCR | May 23, 2023 | NCR | Radiation (03CH01-SZ) |
| Antenna Mast | EM | EM1000 | N/A | 1 m~4 m | NCR | May 23, 2023 | NCR | Radiation (03CH01-SZ) |

NCR: No Calibration Required

6 Measurement Uncertainty

The measurement uncertainties shown below were calculated in accordance with the requirements of ANSI 63.26-2015. All the measurement uncertainty value were shown with a coverage K=2 to indicate 95% level of confidence. The measurement data show herein meets or exceeds the CISPR measurement uncertainty values specified in CISPR 16-4-2 and can be compared directly to specified limit to determine compliance.

Uncertainty of Conducted Measurement

| Test Item | Uncertainty |
|----------------------------|-------------|
| Conducted Power | ±1.34 dB |
| Conducted Emissions | ±1.34 dB |
| Occupied Channel Bandwidth | ±0.13 % |

Uncertainty of Radiated Emission Measurement (30 MHz ~ 1000 MHz)

| | |
|---|--------|
| Measuring Uncertainty for a Level of Confidence of 95% (U = 2Uc(y)) | 2.48dB |
|---|--------|

Uncertainty of Radiated Emission Measurement (1 GHz ~ 18 GHz)

| | |
|---|--------|
| Measuring Uncertainty for a Level of Confidence of 95% (U = 2Uc(y)) | 3.53dB |
|---|--------|

Uncertainty of Radiated Emission Measurement (18 GHz ~ 40 GHz)

| | |
|---|--------|
| Measuring Uncertainty for a Level of Confidence of 95% (U = 2Uc(y)) | 4.02dB |
|---|--------|

----- THE END -----



Appendix A. Test Results of Conducted Test

| | | | |
|-----------------|-------------|---------------------|---------|
| Test Engineer : | Jason Zhang | Temperature : | 24~26°C |
| | | Relative Humidity : | 50~53% |

Conducted Output Power(Average power)

<Ant.5> :

| BW [MHz] | Modulation | RB Size | RB Offset | Power Low Ch. / Freq. | Power Middle Ch. / Freq. | Power High Ch. / Freq. |
|-----------------|------------|---------|-----------|-----------------------|--------------------------|------------------------|
| Channel | | | | 42190 | 42590 | 42990 |
| Frequency (MHz) | | | | 3460 | 3500 | 3540 |
| 20 | QPSK | 1 | 0 | 25.00 | 25.05 | 24.97 |
| 20 | QPSK | 1 | 49 | 24.86 | 24.94 | 24.84 |
| 20 | QPSK | 1 | 99 | 24.75 | 24.89 | 24.83 |
| 20 | QPSK | 50 | 0 | 23.85 | 23.98 | 23.91 |
| 20 | QPSK | 50 | 24 | 23.76 | 23.86 | 23.83 |
| 20 | QPSK | 50 | 50 | 23.79 | 23.87 | 23.78 |
| 20 | QPSK | 100 | 0 | 23.80 | 23.89 | 23.81 |
| 20 | 16QAM | 1 | 0 | 23.69 | 23.77 | 23.71 |
| 20 | 16QAM | 1 | 49 | 23.66 | 23.71 | 23.62 |
| 20 | 16QAM | 1 | 99 | 23.63 | 23.72 | 23.57 |
| 20 | 16QAM | 50 | 0 | 22.94 | 23.03 | 22.92 |
| 20 | 16QAM | 50 | 24 | 22.81 | 22.91 | 22.83 |
| 20 | 16QAM | 50 | 50 | 22.92 | 22.98 | 22.86 |
| 20 | 16QAM | 100 | 0 | 22.84 | 22.88 | 22.74 |
| 20 | 64QAM | 1 | 0 | 22.61 | 22.75 | 22.64 |
| 20 | 64QAM | 1 | 49 | 22.57 | 22.67 | 22.63 |
| 20 | 64QAM | 1 | 99 | 22.53 | 22.57 | 22.53 |
| 20 | 64QAM | 50 | 0 | 21.86 | 21.89 | 21.81 |
| 20 | 64QAM | 50 | 24 | 21.62 | 21.74 | 21.64 |
| 20 | 64QAM | 50 | 50 | 21.61 | 21.75 | 21.69 |
| 20 | 64QAM | 100 | 0 | 21.65 | 21.72 | 21.61 |
| 20 | 256QAM | 1 | 0 | 19.76 | 19.84 | 19.70 |
| 20 | 256QAM | 1 | 49 | 19.67 | 19.80 | 19.67 |
| 20 | 256QAM | 1 | 99 | 19.64 | 19.79 | 19.73 |
| 20 | 256QAM | 50 | 0 | 19.69 | 19.80 | 19.66 |
| 20 | 256QAM | 50 | 24 | 19.57 | 19.63 | 19.51 |
| 20 | 256QAM | 50 | 50 | 19.64 | 19.75 | 19.66 |
| 20 | 256QAM | 100 | 0 | 19.55 | 19.64 | 19.57 |
| Channel | | | | 42165 | 42590 | 43015 |
| Frequency (MHz) | | | | 3457.5 | 3500 | 3542.5 |
| 15 | QPSK | 1 | 0 | 24.92 | 24.98 | 24.84 |
| 15 | QPSK | 1 | 37 | 24.75 | 24.87 | 24.70 |
| 15 | QPSK | 1 | 74 | 24.71 | 24.78 | 24.70 |
| 15 | QPSK | 36 | 0 | 23.75 | 23.92 | 23.82 |



| | | | | | | |
|-----------------|--------|----|----|-------|-------|-------|
| 15 | QPSK | 36 | 20 | 23.61 | 23.74 | 23.73 |
| 15 | QPSK | 36 | 39 | 23.68 | 23.83 | 23.70 |
| 15 | QPSK | 75 | 0 | 23.68 | 23.82 | 23.70 |
| 15 | 16QAM | 1 | 0 | 23.54 | 23.70 | 23.59 |
| 15 | 16QAM | 1 | 37 | 23.53 | 23.60 | 23.59 |
| 15 | 16QAM | 1 | 74 | 23.49 | 23.57 | 23.48 |
| 15 | 16QAM | 36 | 0 | 22.91 | 22.99 | 22.80 |
| 15 | 16QAM | 36 | 20 | 22.71 | 22.81 | 22.73 |
| 15 | 16QAM | 36 | 39 | 22.80 | 22.89 | 22.79 |
| 15 | 16QAM | 75 | 0 | 22.76 | 22.81 | 22.64 |
| 15 | 64QAM | 1 | 0 | 22.55 | 22.68 | 22.60 |
| 15 | 64QAM | 1 | 37 | 22.50 | 22.64 | 22.50 |
| 15 | 64QAM | 1 | 74 | 22.45 | 22.45 | 22.44 |
| 15 | 64QAM | 36 | 0 | 21.73 | 21.83 | 21.71 |
| 15 | 64QAM | 36 | 20 | 21.57 | 21.68 | 21.58 |
| 15 | 64QAM | 36 | 39 | 21.52 | 21.68 | 21.54 |
| 15 | 64QAM | 75 | 0 | 21.62 | 21.60 | 21.51 |
| 15 | 256QAM | 1 | 0 | 19.66 | 19.79 | 19.58 |
| 15 | 256QAM | 1 | 37 | 19.60 | 19.70 | 19.53 |
| 15 | 256QAM | 1 | 74 | 19.53 | 19.69 | 19.62 |
| 15 | 256QAM | 36 | 0 | 19.55 | 19.72 | 19.59 |
| 15 | 256QAM | 36 | 20 | 19.49 | 19.52 | 19.37 |
| 15 | 256QAM | 36 | 39 | 19.59 | 19.61 | 19.58 |
| 15 | 256QAM | 75 | 0 | 19.51 | 19.53 | 19.51 |
| Channel | | | | 42140 | 42590 | 43040 |
| Frequency (MHz) | | | | 3455 | 3500 | 3545 |
| 10 | QPSK | 1 | 0 | 24.88 | 24.96 | 24.82 |
| 10 | QPSK | 1 | 25 | 24.79 | 24.86 | 24.77 |
| 10 | QPSK | 1 | 49 | 24.61 | 24.81 | 24.79 |
| 10 | QPSK | 25 | 0 | 23.80 | 23.93 | 23.80 |
| 10 | QPSK | 25 | 12 | 23.72 | 23.83 | 23.68 |
| 10 | QPSK | 25 | 25 | 23.66 | 23.76 | 23.66 |
| 10 | QPSK | 50 | 0 | 23.73 | 23.85 | 23.74 |
| 10 | 16QAM | 1 | 0 | 23.56 | 23.67 | 23.67 |
| 10 | 16QAM | 1 | 25 | 23.58 | 23.60 | 23.56 |
| 10 | 16QAM | 1 | 49 | 23.58 | 23.67 | 23.42 |
| 10 | 16QAM | 25 | 0 | 22.83 | 22.94 | 22.89 |
| 10 | 16QAM | 25 | 12 | 22.68 | 22.82 | 22.70 |
| 10 | 16QAM | 25 | 25 | 22.85 | 22.93 | 22.76 |
| 10 | 16QAM | 50 | 0 | 22.79 | 22.85 | 22.69 |
| 10 | 64QAM | 1 | 0 | 22.55 | 22.67 | 22.52 |
| 10 | 64QAM | 1 | 25 | 22.52 | 22.59 | 22.58 |
| 10 | 64QAM | 1 | 49 | 22.43 | 22.48 | 22.46 |
| 10 | 64QAM | 25 | 0 | 21.78 | 21.82 | 21.75 |
| 10 | 64QAM | 25 | 12 | 21.58 | 21.59 | 21.59 |
| 10 | 64QAM | 25 | 25 | 21.50 | 21.69 | 21.61 |
| 10 | 64QAM | 50 | 0 | 21.60 | 21.63 | 21.53 |
| 10 | 256QAM | 1 | 0 | 19.72 | 19.80 | 19.56 |
| 10 | 256QAM | 1 | 25 | 19.58 | 19.73 | 19.64 |



| | | | | | | |
|-----------------|--------|----|----|--------|-------|--------|
| 10 | 256QAM | 1 | 49 | 19.51 | 19.70 | 19.67 |
| 10 | 256QAM | 25 | 0 | 19.59 | 19.76 | 19.59 |
| 10 | 256QAM | 25 | 12 | 19.47 | 19.50 | 19.47 |
| 10 | 256QAM | 25 | 25 | 19.55 | 19.63 | 19.57 |
| 10 | 256QAM | 50 | 0 | 19.49 | 19.52 | 19.47 |
| Channel | | | | 42115 | 42590 | 43065 |
| Frequency (MHz) | | | | 3452.5 | 3500 | 3547.5 |
| 5 | QPSK | 1 | 0 | 24.89 | 24.93 | 24.82 |
| 5 | QPSK | 1 | 12 | 24.80 | 24.87 | 24.77 |
| 5 | QPSK | 1 | 24 | 24.66 | 24.75 | 24.72 |
| 5 | QPSK | 12 | 0 | 23.74 | 23.94 | 23.84 |
| 5 | QPSK | 12 | 7 | 23.62 | 23.72 | 23.72 |
| 5 | QPSK | 12 | 13 | 23.75 | 23.81 | 23.75 |
| 5 | QPSK | 25 | 0 | 23.75 | 23.77 | 23.74 |
| 5 | 16QAM | 1 | 0 | 23.58 | 23.74 | 23.57 |
| 5 | 16QAM | 1 | 12 | 23.56 | 23.56 | 23.53 |
| 5 | 16QAM | 1 | 24 | 23.58 | 23.67 | 23.43 |
| 5 | 16QAM | 12 | 0 | 22.85 | 22.94 | 22.77 |
| 5 | 16QAM | 12 | 7 | 22.68 | 22.87 | 22.71 |
| 5 | 16QAM | 12 | 13 | 22.86 | 22.84 | 22.71 |
| 5 | 16QAM | 25 | 0 | 22.72 | 22.84 | 22.68 |
| 5 | 64QAM | 1 | 0 | 22.48 | 22.65 | 22.50 |
| 5 | 64QAM | 1 | 12 | 22.46 | 22.62 | 22.57 |
| 5 | 64QAM | 1 | 24 | 22.49 | 22.47 | 22.44 |
| 5 | 64QAM | 12 | 0 | 21.77 | 21.86 | 21.72 |
| 5 | 64QAM | 12 | 7 | 21.56 | 21.61 | 21.58 |
| 5 | 64QAM | 12 | 13 | 21.57 | 21.64 | 21.60 |
| 5 | 64QAM | 25 | 0 | 21.53 | 21.68 | 21.58 |
| 5 | 256QAM | 1 | 0 | 19.64 | 19.76 | 19.56 |
| 5 | 256QAM | 1 | 12 | 19.56 | 19.71 | 19.62 |
| 5 | 256QAM | 1 | 24 | 19.60 | 19.71 | 19.59 |
| 5 | 256QAM | 12 | 0 | 19.58 | 19.76 | 19.59 |
| 5 | 256QAM | 12 | 7 | 19.49 | 19.48 | 19.47 |
| 5 | 256QAM | 12 | 13 | 19.59 | 19.69 | 19.58 |
| 5 | 256QAM | 25 | 0 | 19.49 | 19.50 | 19.45 |



EIRP

| LTE Band 42 (GT - LC = -0.90 dB) QPSK | | | | | | | | | |
|---------------------------------------|----------------|----------------|-----------------|----------------|----------------|-----------------|----------------|----------------|-----------------|
| Bandwidth | 5M | | | 10M | | | 15M | | |
| Channel | 42115 (Low) | 42590 (Mid) | 43065 (High) | 42140 (Low) | 42590 (Mid) | 43040 (High) | 42165 (Low) | 42590 (Mid) | 43015 (High) |
| Frequency (MHz) | 3452.5 | 3500 | 3547.5 | 3455 | 3500 | 3545 | 3457.5 | 3500 | 3542.5 |
| Conducted Power (dBm) | 24.89 | 24.93 | 24.82 | 24.88 | 24.96 | 24.82 | 24.92 | 24.98 | 24.84 |
| Conducted Power (Watts) | 0.3083 | 0.3112 | 0.3034 | 0.3076 | 0.3133 | 0.3034 | 0.3105 | 0.3148 | 0.3048 |
| EIRP(dBm) | 23.99 | 24.03 | 23.92 | 23.98 | 24.06 | 23.92 | 24.02 | 24.08 | 23.94 |
| EIRP(Watts) | 0.2506 | 0.2529 | 0.2466 | 0.2500 | 0.2547 | 0.2466 | 0.2523 | 0.2559 | 0.2477 |

| LTE Band 42 (GT - LC = -0.90 dB) QPSK | | | |
|---------------------------------------|----------------|----------------|-----------------|
| Bandwidth | 20M | | |
| Channel | 42190 (Low) | 42590 (Mid) | 42990 (High) |
| Frequency (MHz) | 3460 | 3500 | 3540 |
| Conducted Power (dBm) | 25.00 | 25.05 | 24.97 |
| Conducted Power (Watts) | 0.3162 | 0.3199 | 0.3141 |
| EIRP(dBm) | 24.10 | 24.15 | 24.07 |
| EIRP(Watts) | 0.2570 | 0.2600 | 0.2553 |



| LTE Band 42 (GT - LC = -0.90 dB) 16QAM | | | | | | | | | |
|--|--------|--------|--------|--------|--------|--------|--------|--------|--------|
| Bandwidth | 5M | | | 10M | | | 15M | | |
| Channel | 42115 | 42590 | 43065 | 42140 | 42590 | 43040 | 42165 | 42590 | 43015 |
| | (Low) | (Mid) | (High) | (Low) | (Mid) | (High) | (Low) | (Mid) | (High) |
| Frequency (MHz) | 3452.5 | 3500 | 3547.5 | 3455 | 3500 | 3545 | 3457.5 | 3500 | 3542.5 |
| Conducted Power (dBm) | 23.58 | 23.74 | 23.57 | 23.56 | 23.67 | 23.67 | 23.54 | 23.70 | 23.59 |
| Conducted Power (Watts) | 0.2280 | 0.2366 | 0.2275 | 0.2270 | 0.2328 | 0.2328 | 0.2259 | 0.2344 | 0.2286 |
| EIRP(dBm) | 22.68 | 22.84 | 22.67 | 22.66 | 22.77 | 22.77 | 22.64 | 22.80 | 22.69 |
| EIRP(Watts) | 0.1854 | 0.1923 | 0.1849 | 0.1845 | 0.1892 | 0.1892 | 0.1837 | 0.1905 | 0.1858 |

| LTE Band 42 (GT - LC = -0.90 dB) 16QAM | | | |
|--|--------|--------|--------|
| Bandwidth | 20M | | |
| Channel | 42190 | 42590 | 42990 |
| | (Low) | (Mid) | (High) |
| Frequency (MHz) | 3460 | 3500 | 3540 |
| Conducted Power (dBm) | 23.69 | 23.77 | 23.71 |
| Conducted Power (Watts) | 0.2339 | 0.2382 | 0.2350 |
| EIRP(dBm) | 22.79 | 22.87 | 22.81 |
| EIRP(Watts) | 0.1901 | 0.1936 | 0.1910 |



| LTE Band 42 (GT - LC = -0.90 dB) 64QAM | | | | | | | | | |
|--|--------|--------|--------|--------|--------|--------|--------|--------|--------|
| Bandwidth | 5M | | | 10M | | | 15M | | |
| Channel | 42115 | 42590 | 43065 | 42140 | 42590 | 43040 | 42165 | 42590 | 43015 |
| | (Low) | (Mid) | (High) | (Low) | (Mid) | (High) | (Low) | (Mid) | (High) |
| Frequency (MHz) | 3452.5 | 3500 | 3547.5 | 3455 | 3500 | 3545 | 3457.5 | 3500 | 3542.5 |
| Conducted Power (dBm) | 22.48 | 22.65 | 22.50 | 22.55 | 22.67 | 22.52 | 22.55 | 22.68 | 22.60 |
| Conducted Power (Watts) | 0.1770 | 0.1841 | 0.1778 | 0.1799 | 0.1849 | 0.1786 | 0.1799 | 0.1854 | 0.1820 |
| EIRP(dBm) | 21.58 | 21.75 | 21.60 | 21.65 | 21.77 | 21.62 | 21.65 | 21.78 | 21.70 |
| EIRP(Watts) | 0.1439 | 0.1496 | 0.1445 | 0.1462 | 0.1503 | 0.1452 | 0.1462 | 0.1507 | 0.1479 |

| LTE Band 42 (GT - LC = -0.90 dB) 64QAM | | | |
|--|--------|--------|--------|
| Bandwidth | 20M | | |
| Channel | 42190 | 42590 | 42990 |
| | (Low) | (Mid) | (High) |
| Frequency (MHz) | 3460 | 3500 | 3540 |
| Conducted Power (dBm) | 22.61 | 22.75 | 22.64 |
| Conducted Power (Watts) | 0.1824 | 0.1884 | 0.1837 |
| EIRP(dBm) | 21.71 | 21.85 | 21.74 |
| EIRP(Watts) | 0.1483 | 0.1531 | 0.1493 |



| LTE Band 42 (GT - LC = -0.90 dB) 256QAM | | | | | | | | | |
|---|--------|--------|--------|--------|--------|--------|--------|--------|--------|
| Bandwidth | 5M | | | 10M | | | 15M | | |
| Channel | 42115 | 42590 | 43065 | 42140 | 42590 | 43040 | 42165 | 42590 | 43015 |
| | (Low) | (Mid) | (High) | (Low) | (Mid) | (High) | (Low) | (Mid) | (High) |
| Frequency (MHz) | 3452.5 | 3500 | 3547.5 | 3455 | 3500 | 3545 | 3457.5 | 3500 | 3542.5 |
| Conducted Power (dBm) | 19.64 | 19.76 | 19.56 | 19.72 | 19.80 | 19.56 | 19.66 | 19.79 | 19.58 |
| Conducted Power (Watts) | 0.0920 | 0.0946 | 0.0904 | 0.0938 | 0.0955 | 0.0904 | 0.0925 | 0.0953 | 0.0908 |
| EIRP(dBm) | 18.74 | 18.86 | 18.66 | 18.82 | 18.90 | 18.66 | 18.76 | 18.89 | 18.68 |
| EIRP(Watts) | 0.0748 | 0.0769 | 0.0735 | 0.0762 | 0.0776 | 0.0735 | 0.0752 | 0.0774 | 0.0738 |

| LTE Band 42 (GT - LC = -0.90 dB) 256QAM | | | |
|---|--------|--------|--------|
| Bandwidth | 20M | | |
| Channel | 42190 | 42590 | 42990 |
| | (Low) | (Mid) | (High) |
| Frequency (MHz) | 3460 | 3500 | 3540 |
| Conducted Power (dBm) | 19.76 | 19.84 | 19.70 |
| Conducted Power (Watts) | 0.0946 | 0.0964 | 0.0933 |
| EIRP(dBm) | 18.86 | 18.94 | 18.80 |
| EIRP(Watts) | 0.0769 | 0.0783 | 0.0759 |



Peak-to-Average Ratio

| Mode | LTE Band 42 / 20MHz | | | |
|-----------|---------------------|---------|---------|-------------|
| Mod. | QPSK | 16QAM | 64QAM | Limit: 13dB |
| RB Size | Full RB | Full RB | Full RB | Result |
| Middle CH | 6.38 | 6.41 | 7.30 | PASS |

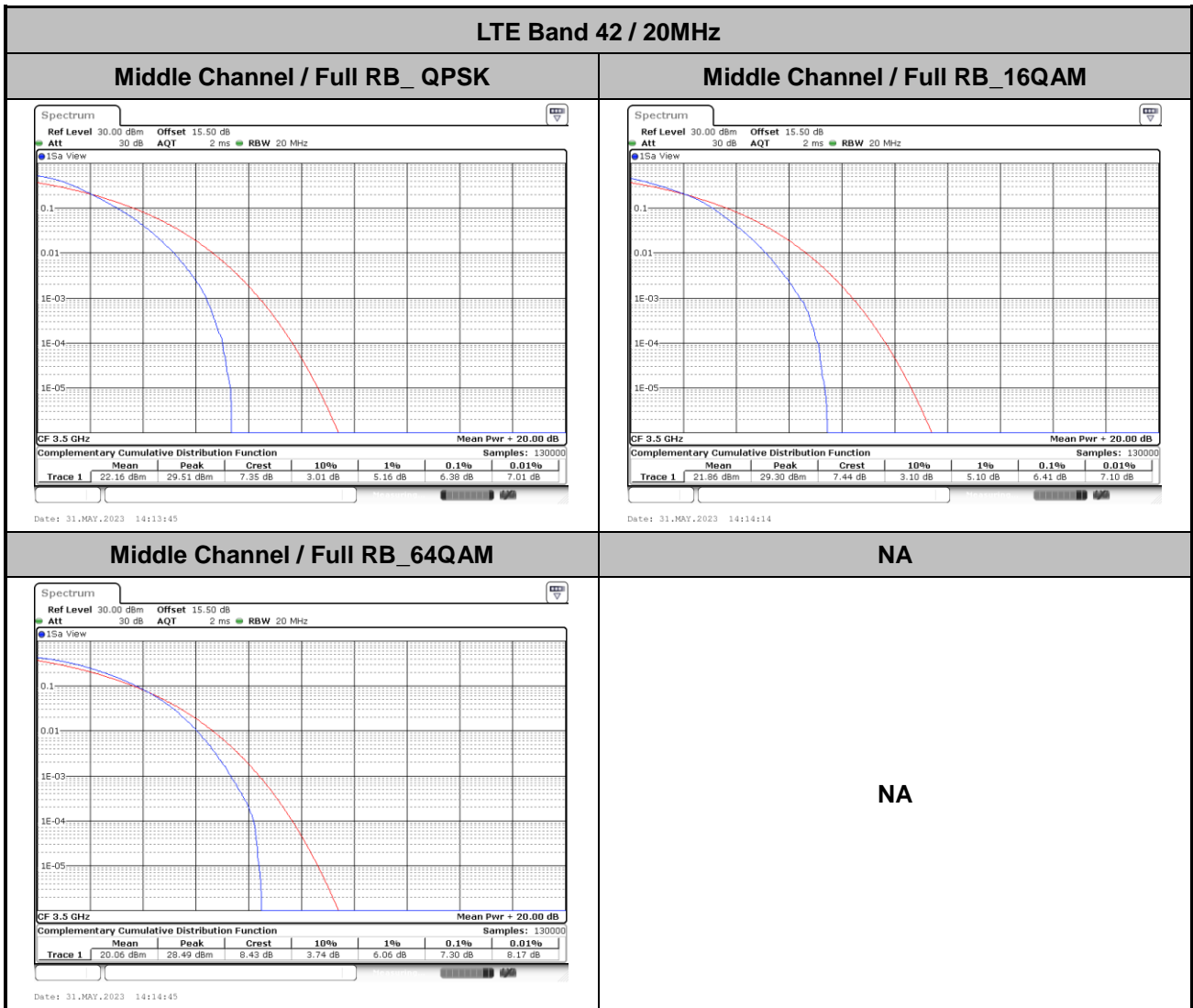



26dB Bandwidth

| | | |
|-----------|----------------------------|-------|
| Mode | LTE Band 42 : 26dB BW(MHz) | |
| BW | 20MHz | |
| Mod. | QPSK | 16QAM |
| Middle CH | 18.62 | 18.66 |

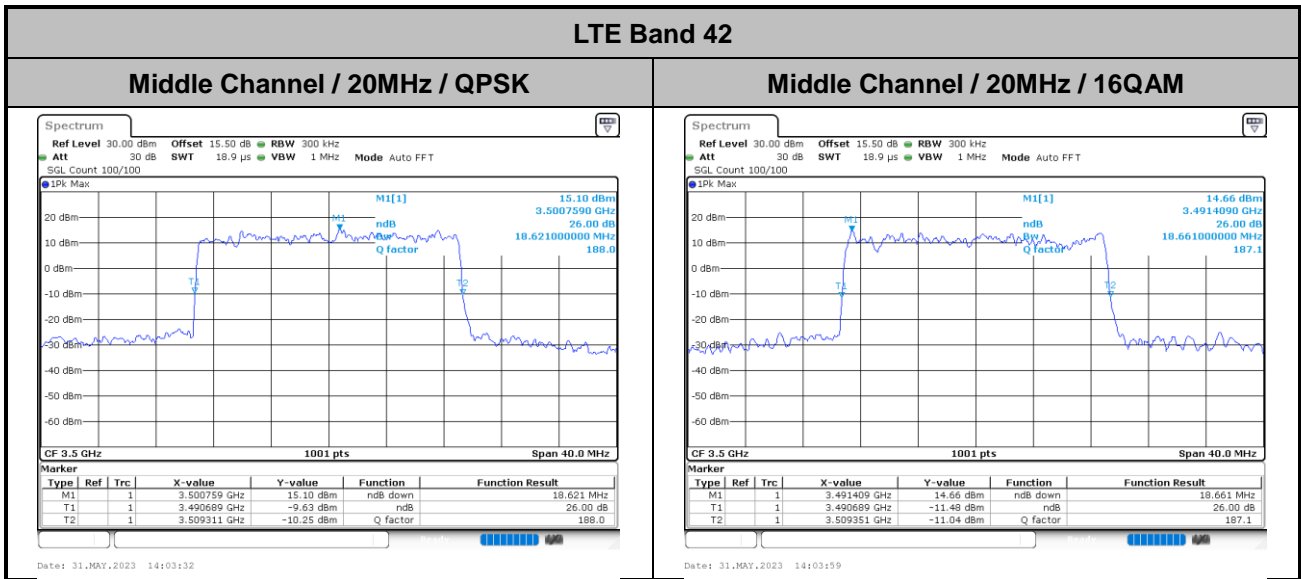



Occupied Bandwidth

| | | |
|-----------|---------------------------|-------|
| Mode | LTE Band 42 : 99%OBW(MHz) | |
| BW | 20MHz | |
| Mod. | QPSK | 16QAM |
| Middle CH | 17.94 | 17.78 |

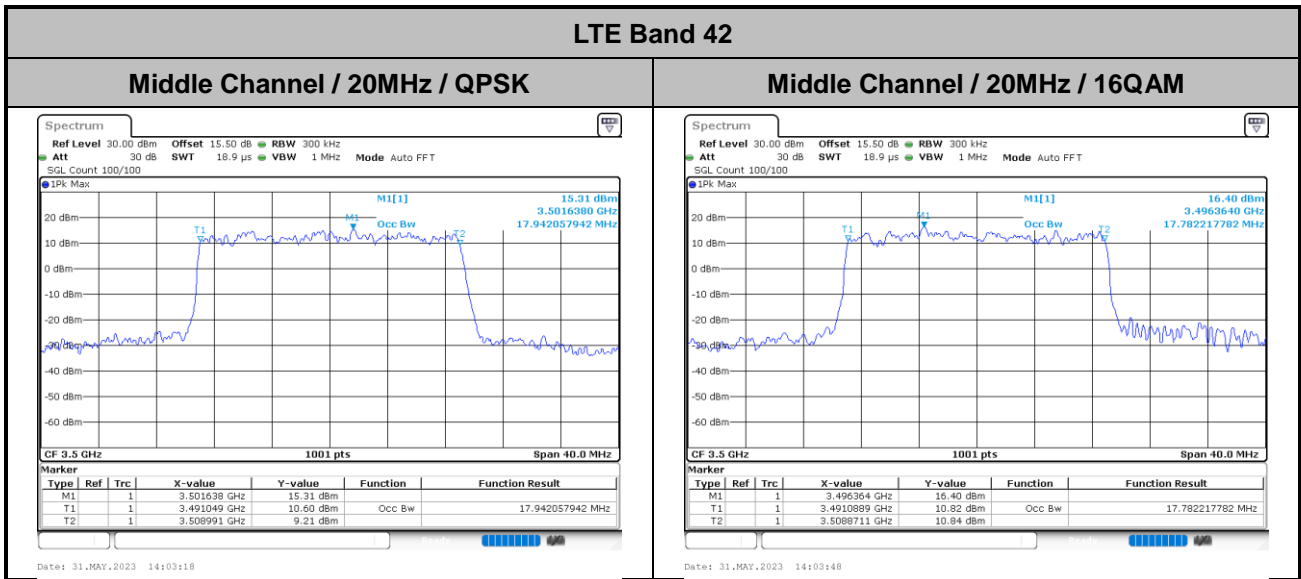



Conducted Band Edge

LTE Band 42 / 5MHz / QPSK

Lowest Band Edge / 1 RB

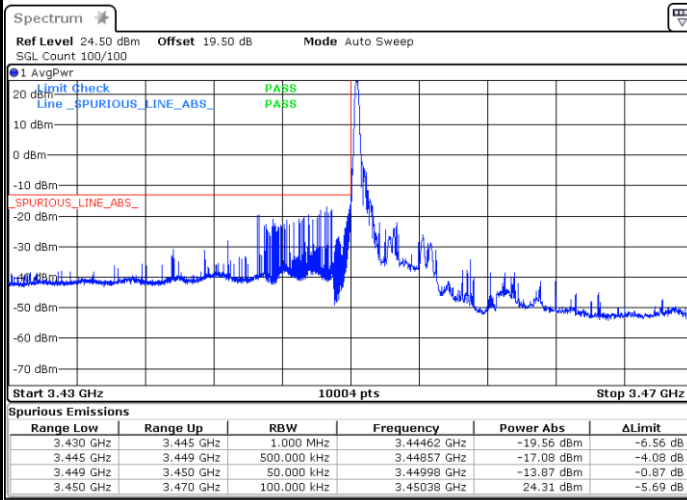

Highest Band Edge / 1 RB

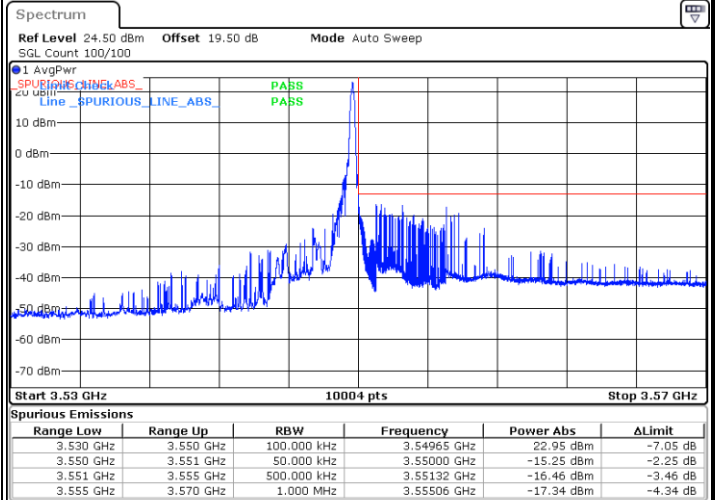

Lowest Band Edge / Full RB

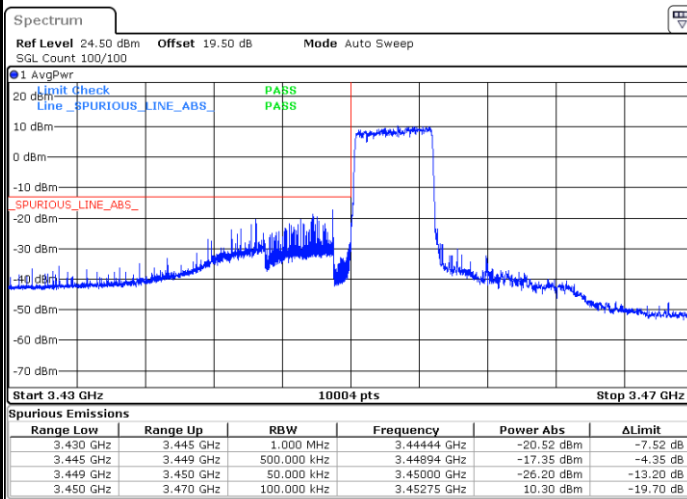

Highest Band Edge / Full RB

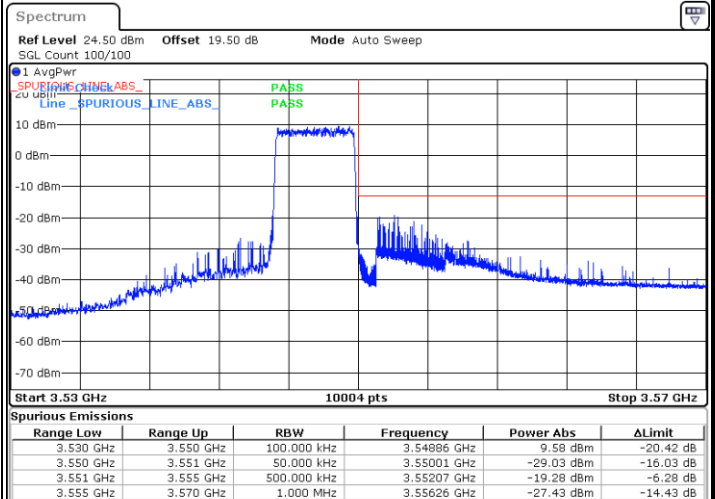



LTE Band 42 / 5MHz / 16QAM

Lowest Band Edge / 1 RB

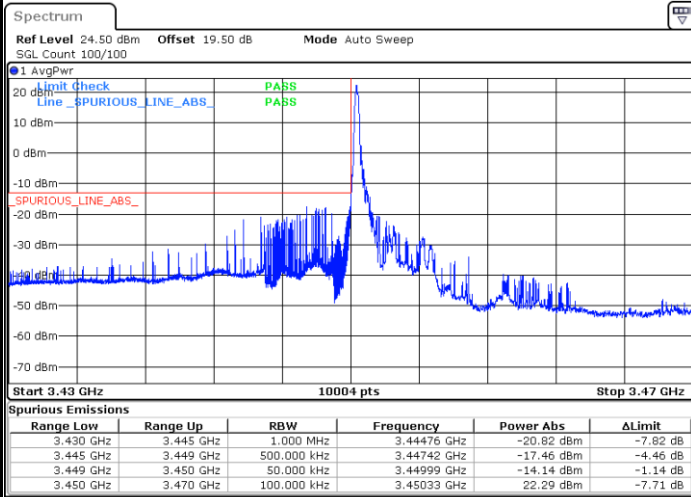

Date: 31.MAY.2023 11:09:46

Highest Band Edge / 1 RB

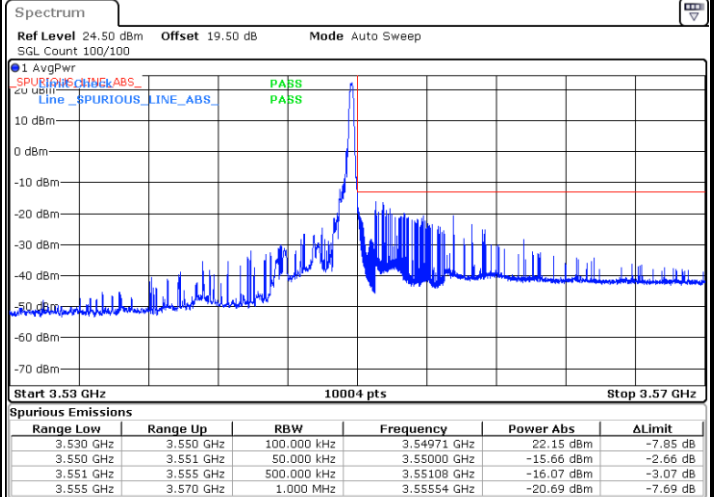

Date: 31.MAY.2023 11:24:48

Lowest Band Edge / Full RB

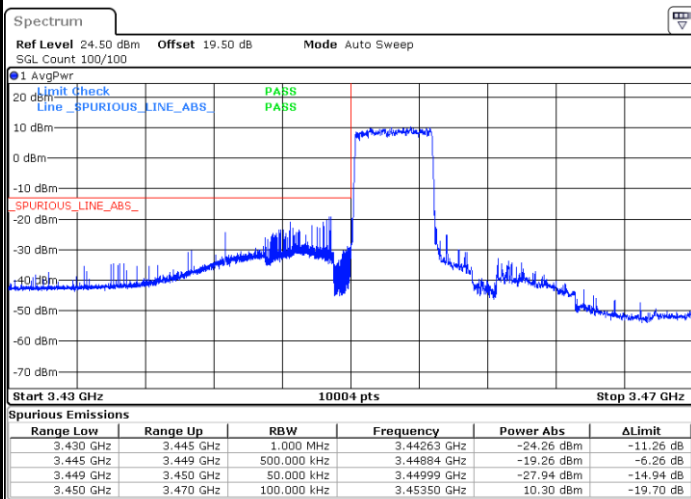

Date: 31.MAY.2023 10:58:13

Highest Band Edge / Full RB

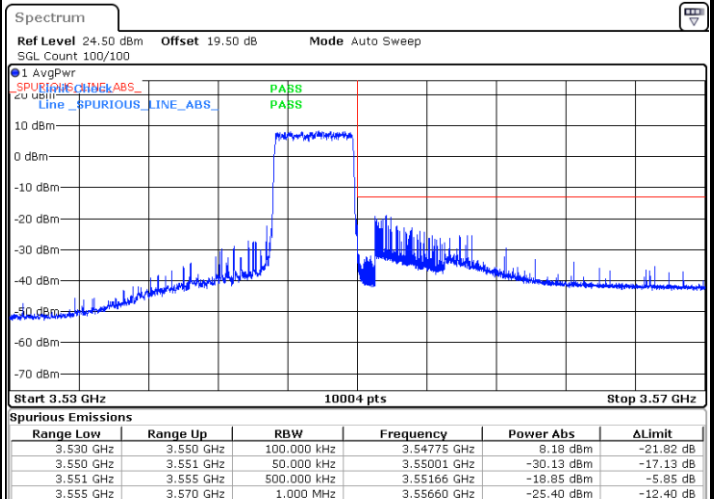

Date: 31.MAY.2023 11:26:28



LTE Band 42 / 5MHz / 64QAM

Lowest Band Edge / 1RB

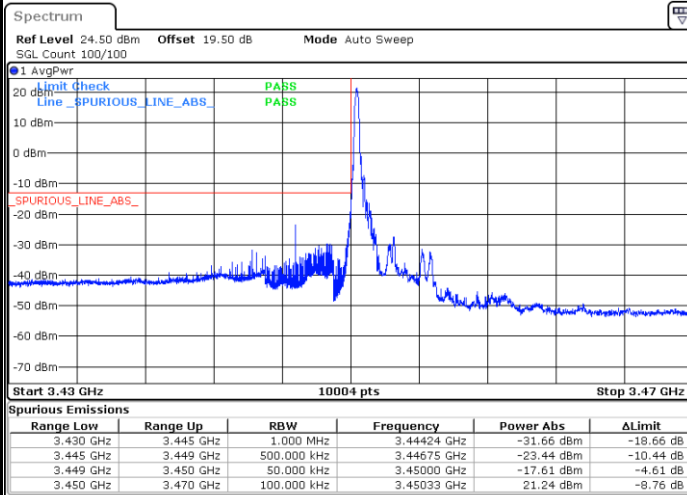

Date: 31.MAY.2023 10:59:29

Highest Band Edge / 1 RB

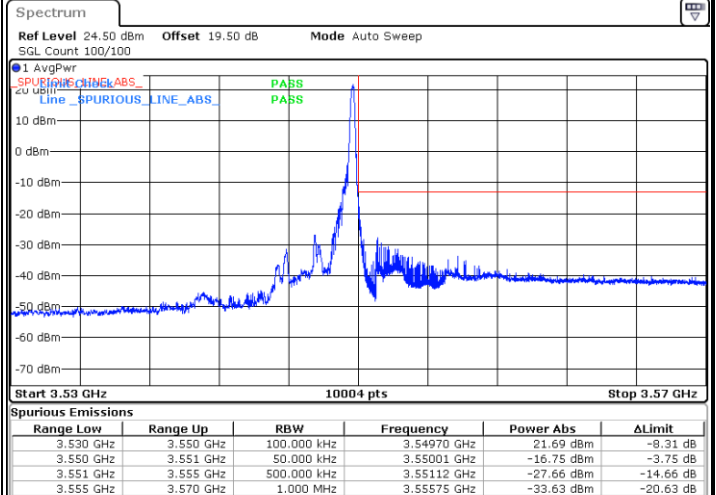

Date: 31.MAY.2023 11:25:21

Lowest Band Edge / Full RB

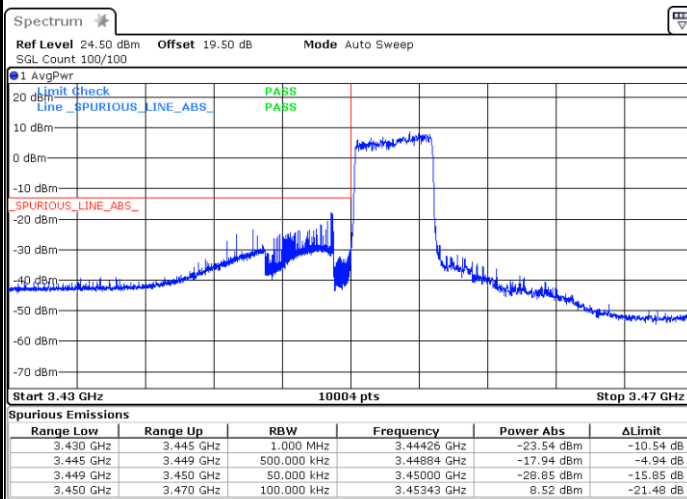

Date: 31.MAY.2023 10:58:58

Highest Band Edge / Full RB

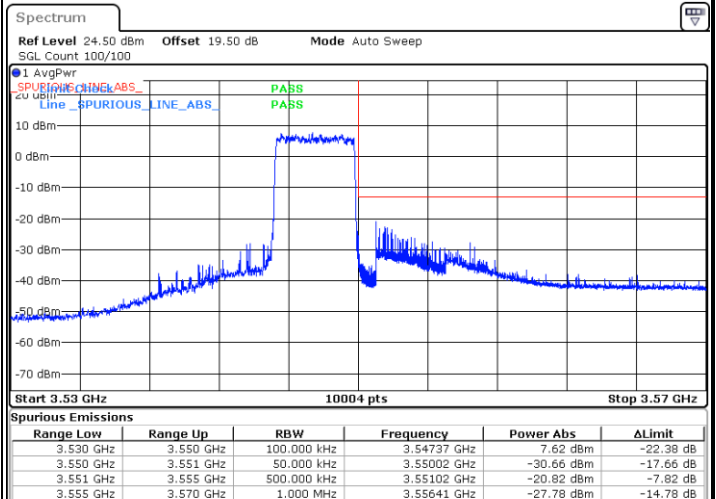

Date: 31.MAY.2023 11:25:55



LTE Band 42 / 10MHz / QPSK

Lowest Band Edge / 1 RB

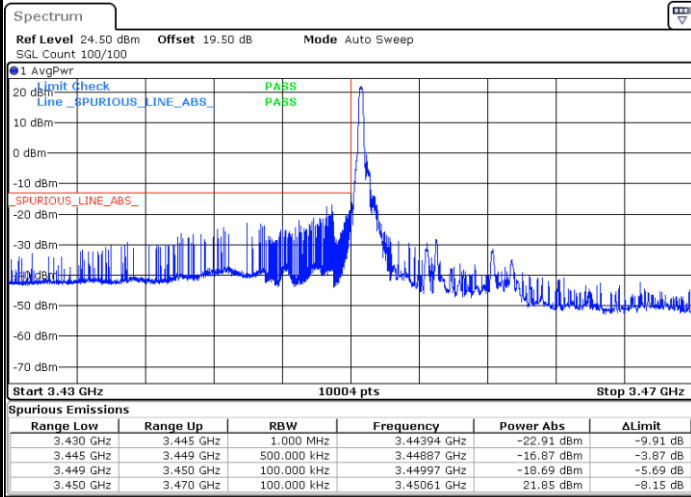

Date: 31.MAY.2023 11:48:54

Highest Band Edge / 1 RB

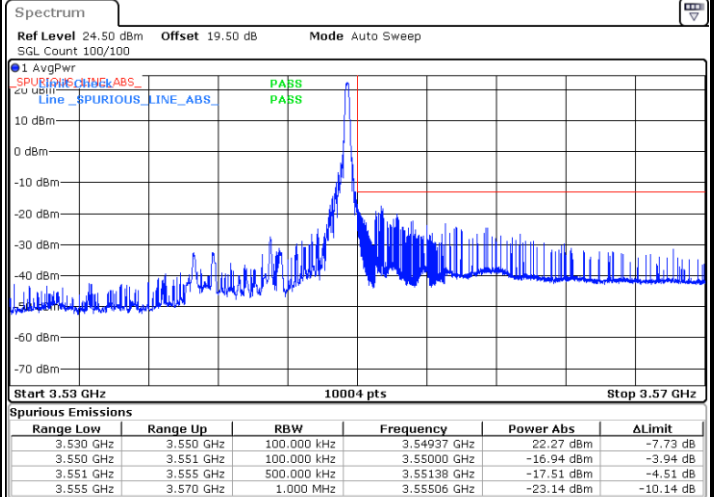

Date: 31.MAY.2023 13:04:27

Lowest Band Edge / Full RB

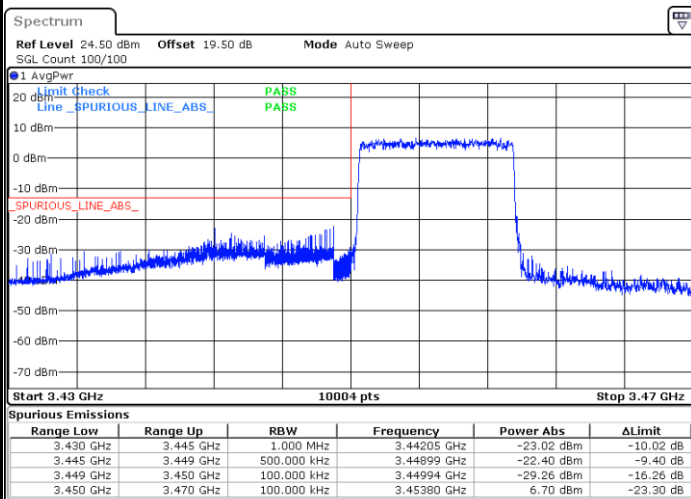

Date: 31.MAY.2023 11:43:51

Highest Band Edge / Full RB

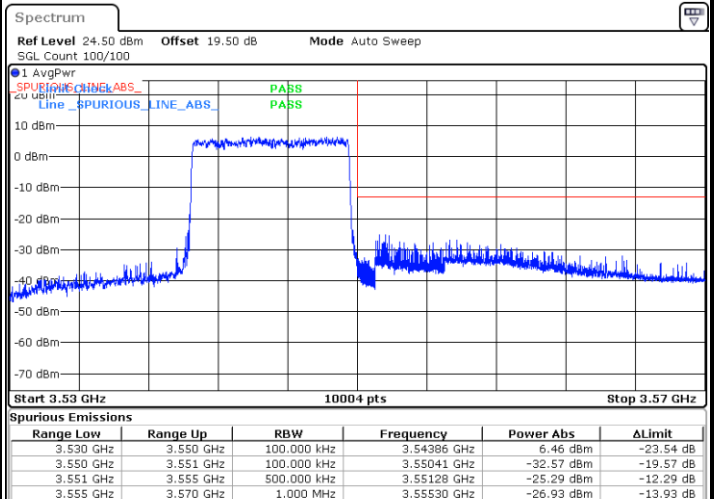

Date: 31.MAY.2023 13:06:48



LTE Band 42 / 10MHz / 16QAM

Lowest Band Edge / 1 RB

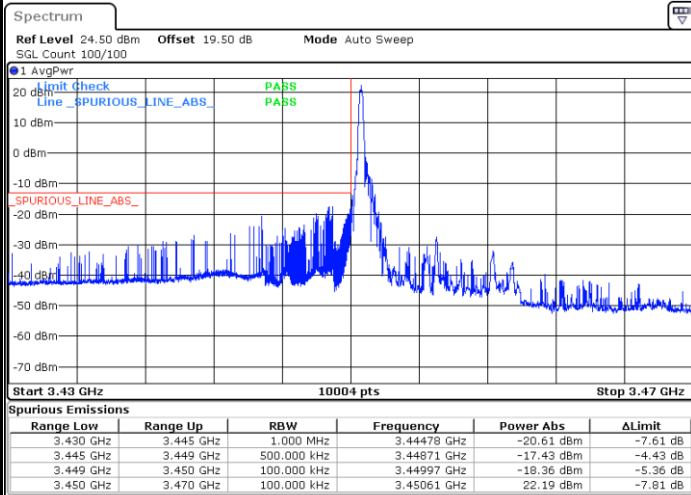

Date: 31.MAY.2023 11:47:09

Highest Band Edge / 1 RB

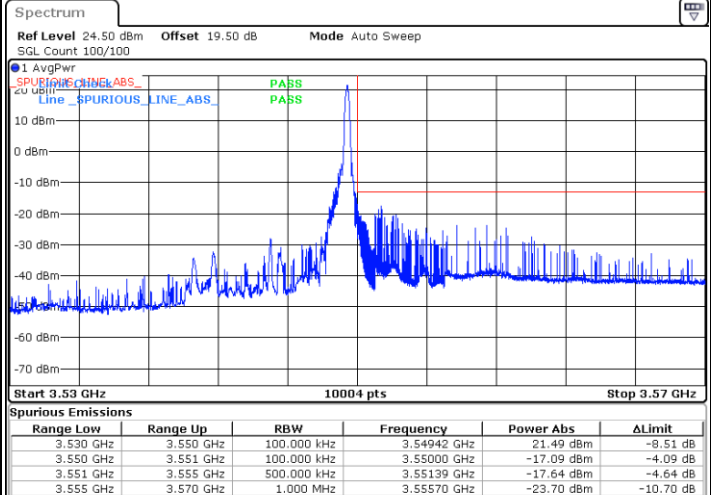

Date: 31.MAY.2023 13:04:55

Lowest Band Edge / Full RB

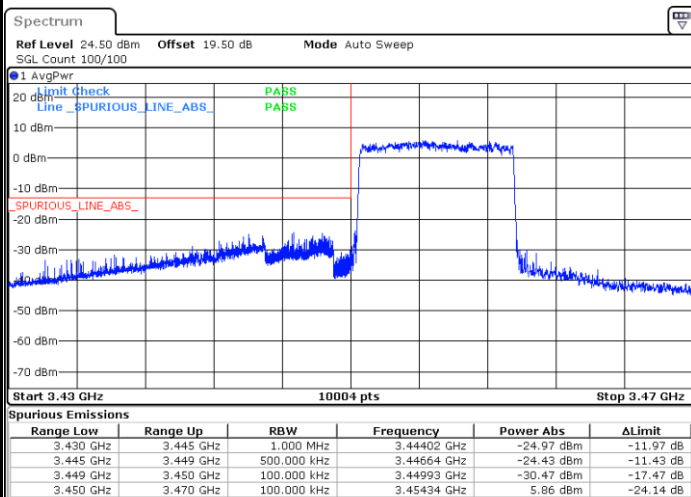

Date: 31.MAY.2023 11:44:22

Highest Band Edge / Full RB

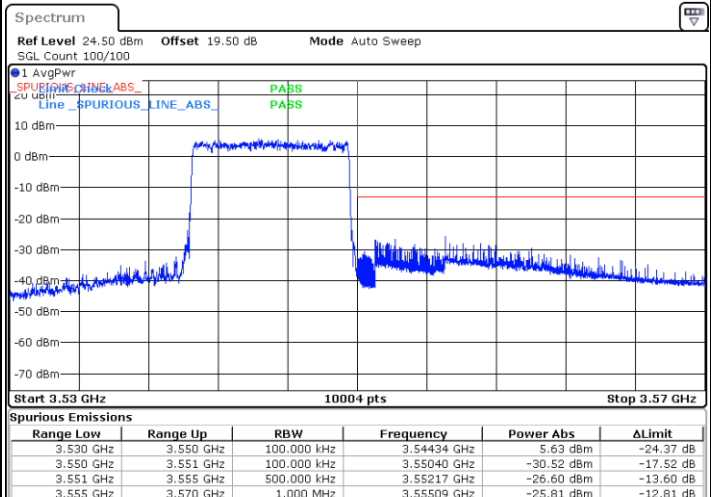

Date: 31.MAY.2023 13:06:19



LTE Band 42 / 10MHz / 64QAM

Lowest Band Edge / 1 RB

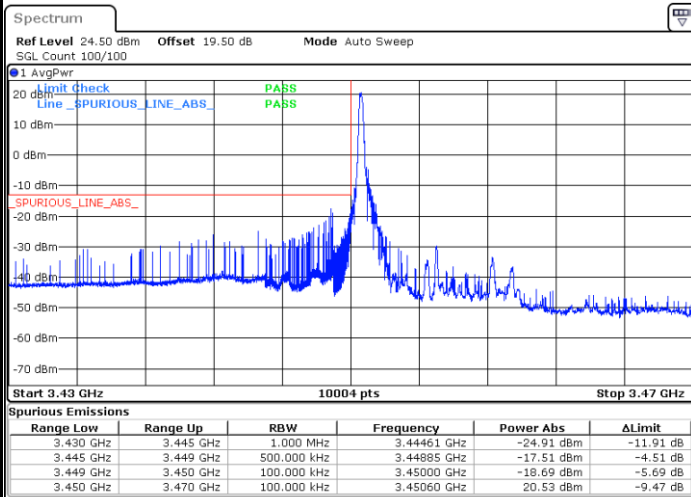

Date: 31.MAY.2023 11:45:21

Highest Band Edge / 1 RB

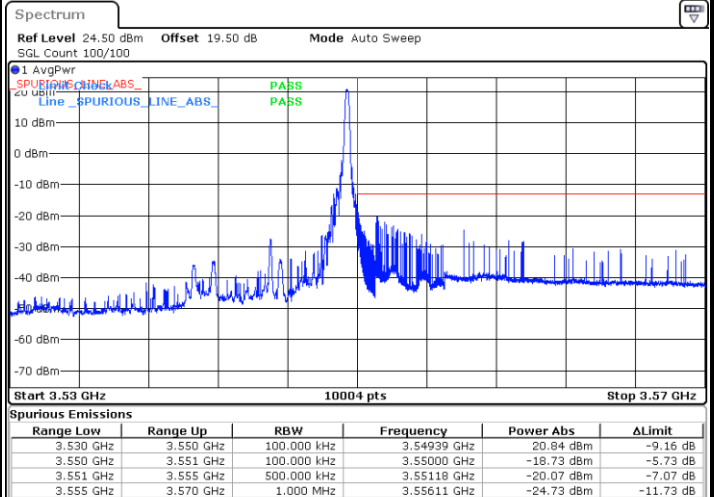

Date: 31.MAY.2023 13:05:22

Lowest Band Edge / Full RB

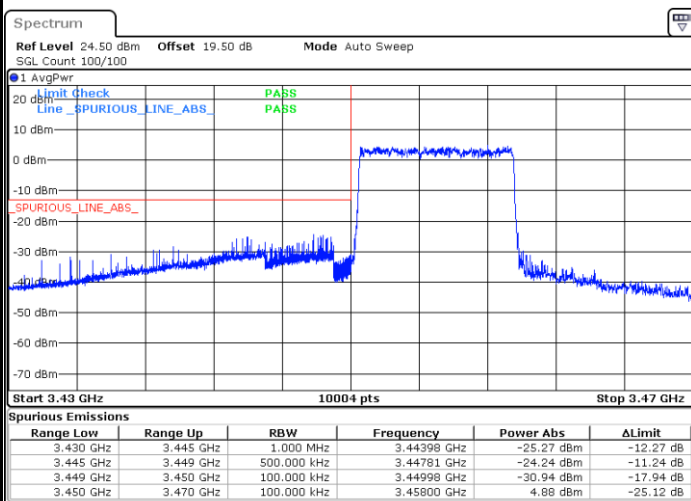

Date: 31.MAY.2023 11:44:49

Highest Band Edge / Full RB

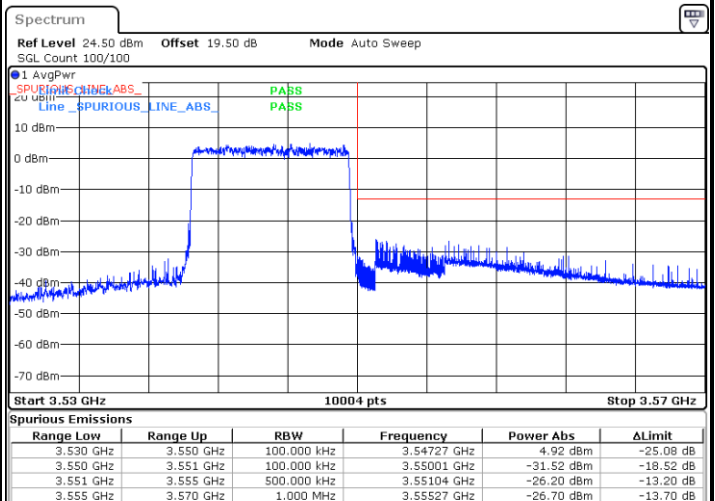

Date: 31.MAY.2023 13:05:51



LTE Band 42 / 15MHz / QPSK

Lowest Band Edge / 1 RB

Highest Band Edge / 1 RB

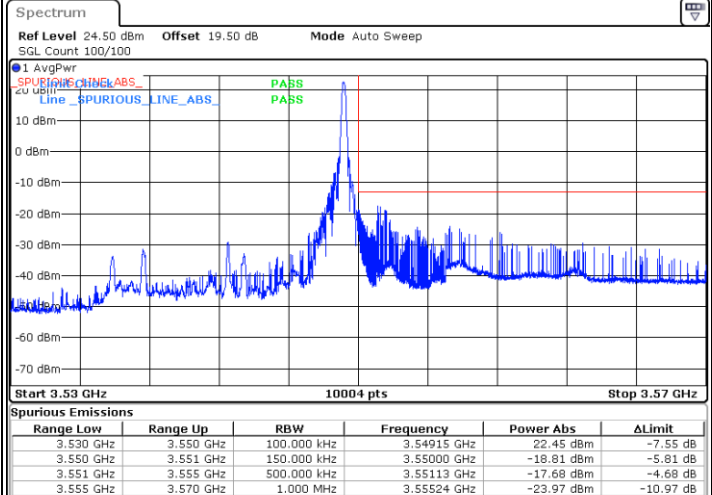
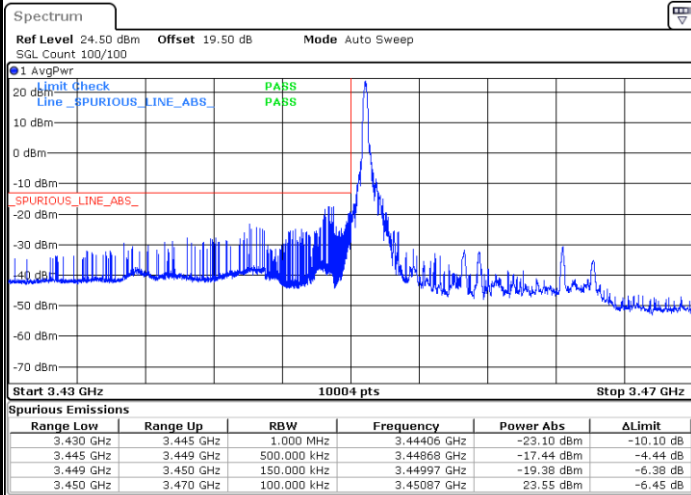

Date: 31.MAY.2023 13:13:31

Date: 31.MAY.2023 13:29:44

Lowest Band Edge / Full RB

Highest Band Edge / Full RB

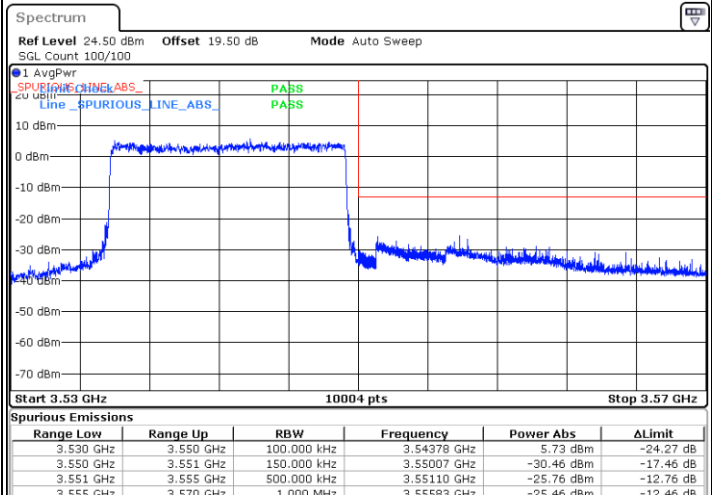
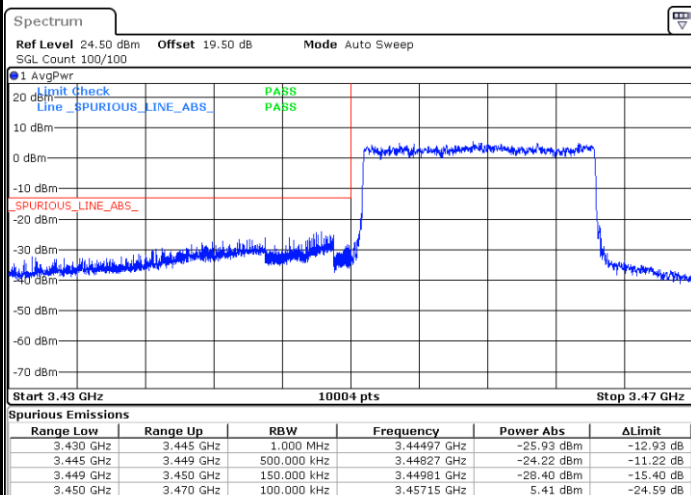

Date: 31.MAY.2023 13:20:27

Date: 31.MAY.2023 13:32:18



LTE Band 42 / 15MHz / 16QAM

Lowest Band Edge / 1 RB

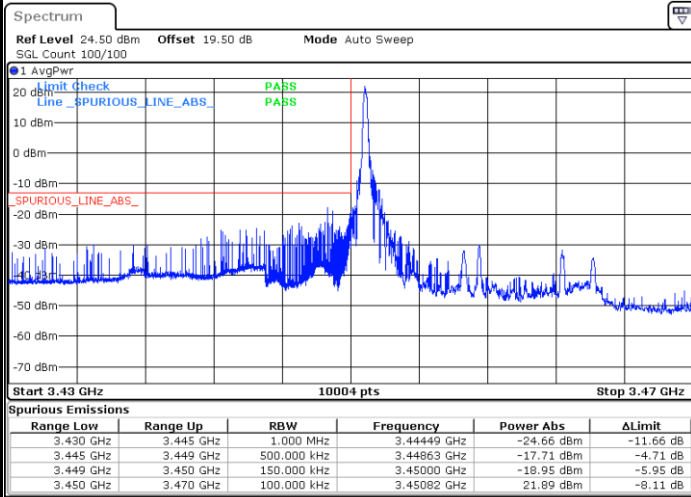

Date: 31.MAY.2023 13:15:14

Highest Band Edge / 1 RB

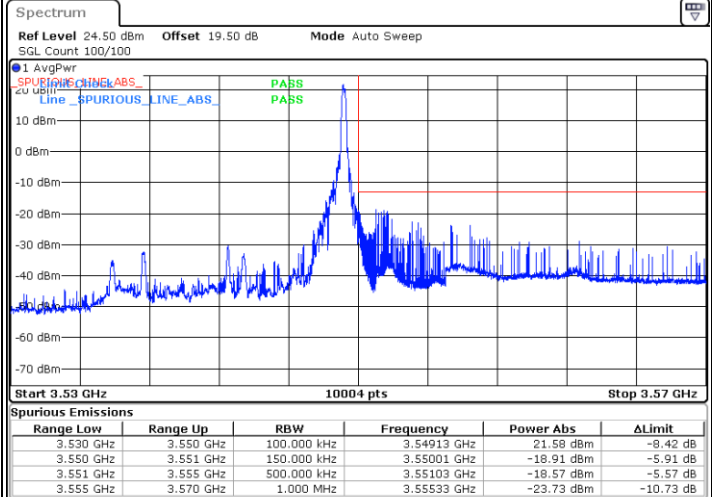

Date: 31.MAY.2023 13:30:17

Lowest Band Edge / Full RB

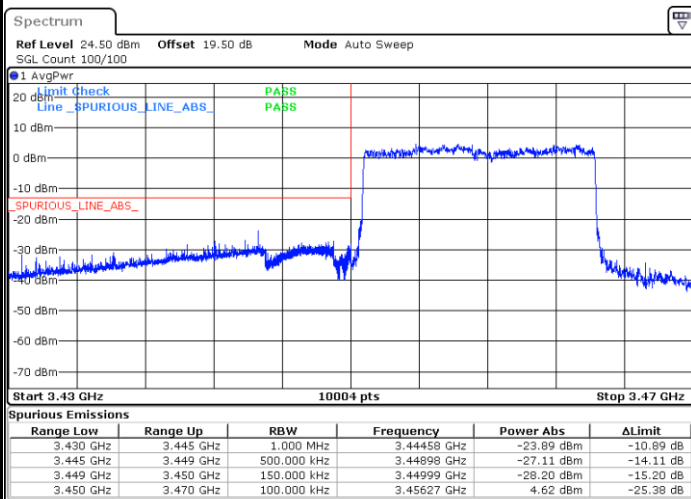

Date: 31.MAY.2023 13:19:28

Highest Band Edge / Full RB

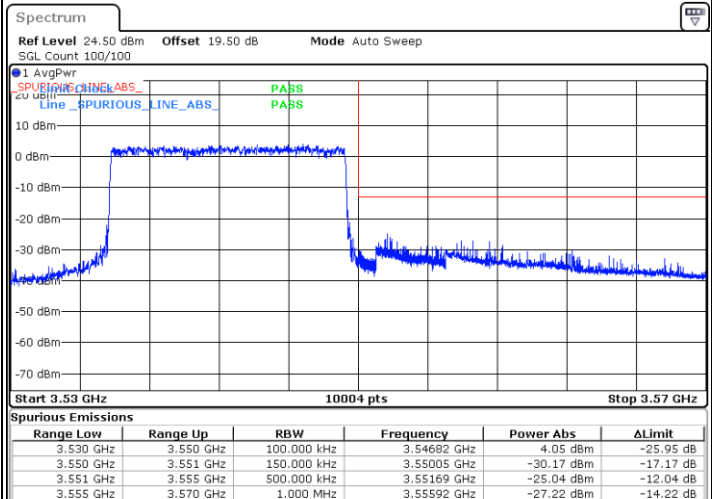

Date: 31.MAY.2023 13:31:46



LTE Band 42 / 15MHz / 64QAM

Lowest Band Edge / 1 RB

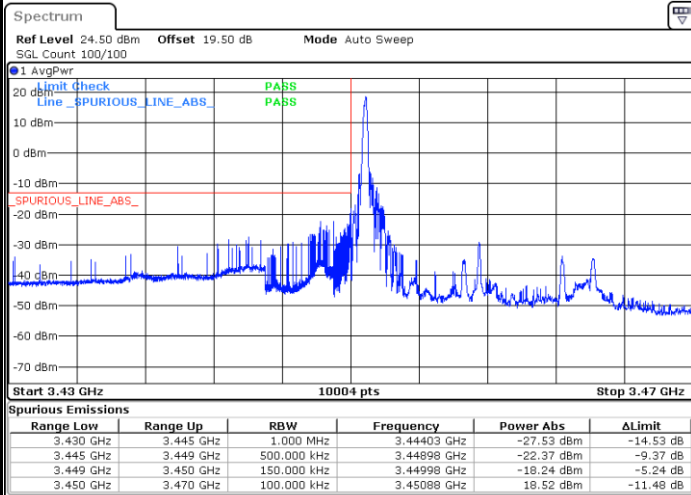

Date: 31.MAY.2023 13:16:58

Highest Band Edge / 1 RB

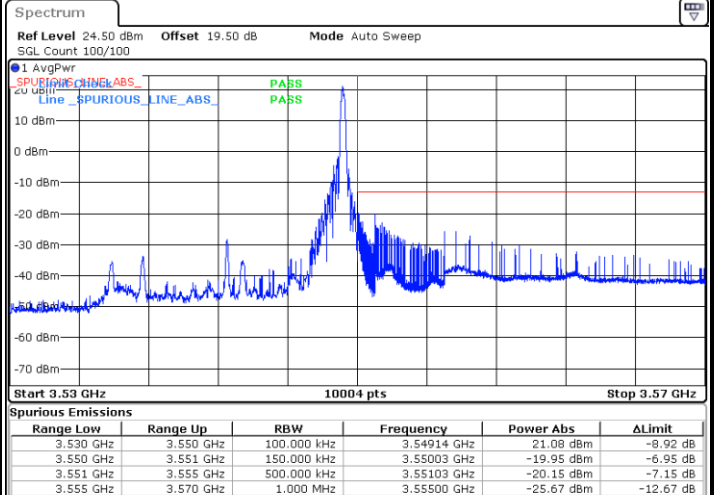

Date: 31.MAY.2023 13:30:48

Lowest Band Edge / Full RB

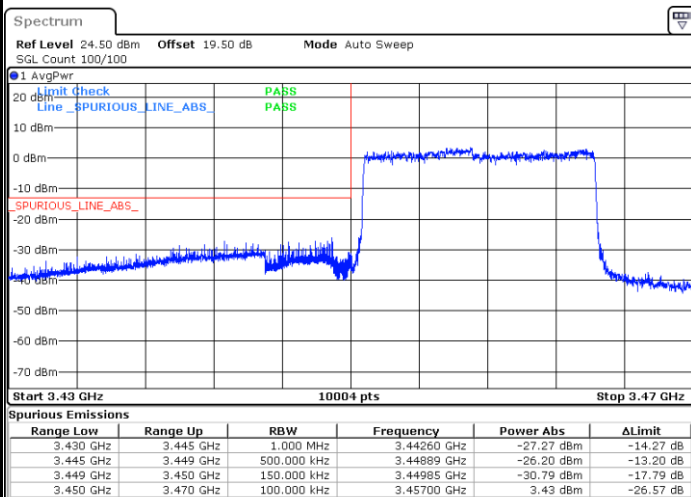

Date: 31.MAY.2023 13:18:55

Highest Band Edge / Full RB

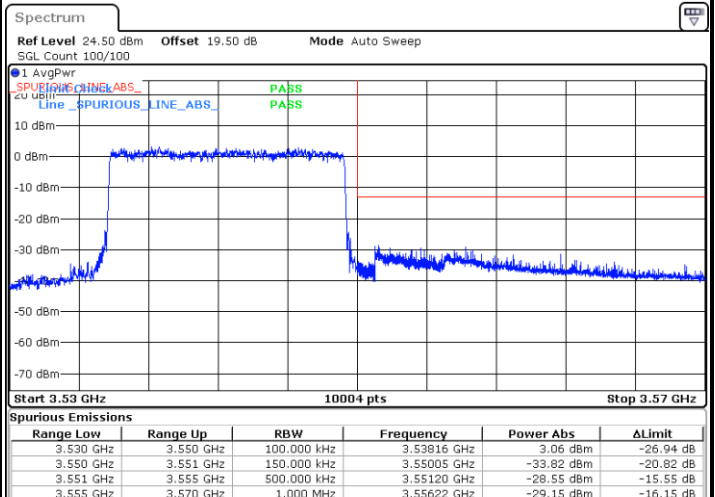

Date: 31.MAY.2023 13:31:19



LTE Band 42 / 20MHz / QPSK

Lowest Band Edge / 1 RB

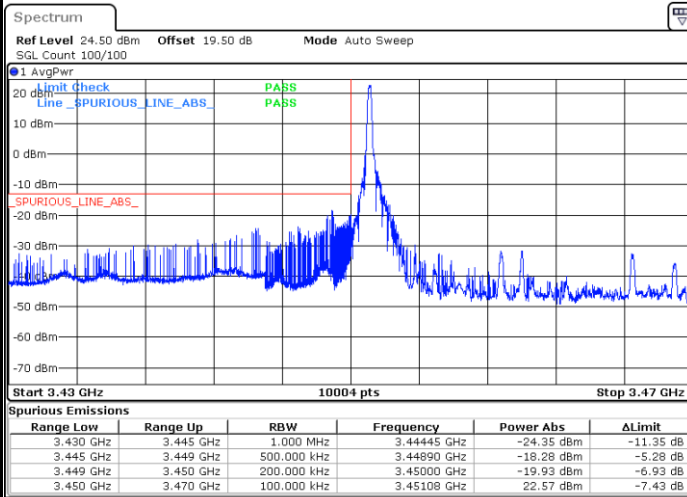

Date: 31.MAY.2023 13:40:52

Highest Band Edge / 1 RB

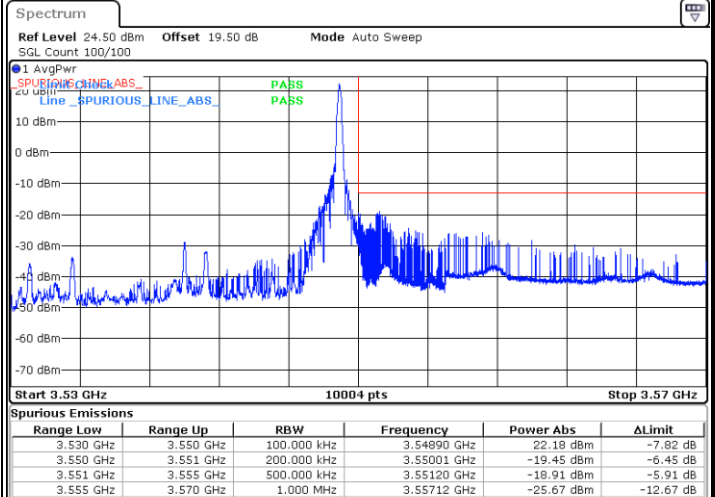

Date: 31.MAY.2023 13:59:47

Lowest Band Edge / Full RB

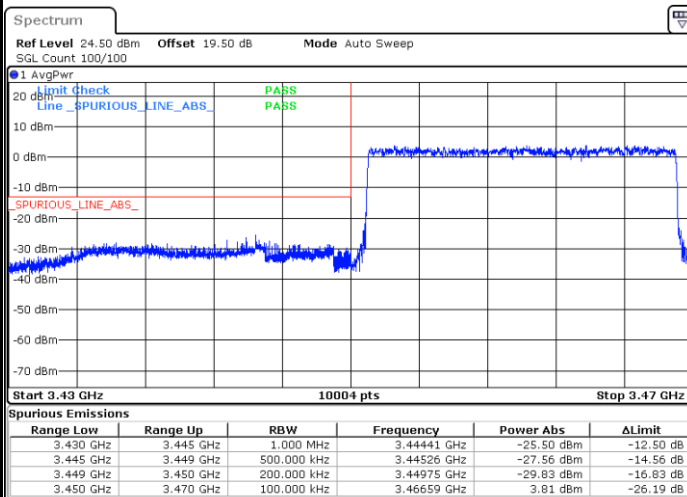

Date: 31.MAY.2023 13:55:30

Highest Band Edge / Full RB

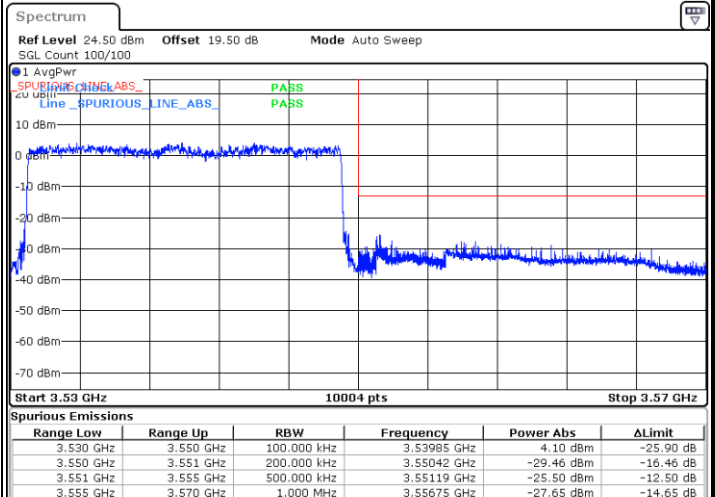

Date: 31.MAY.2023 13:59:02



LTE Band 42 / 20MHz / 16QAM

Lowest Band Edge / 1 RB

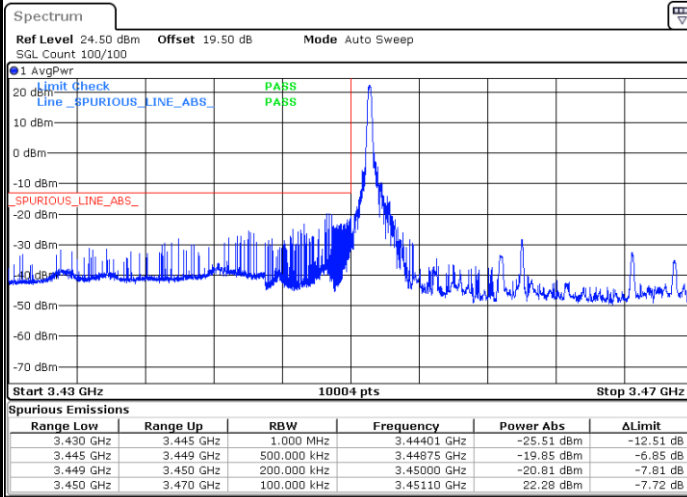

Date: 31.MAY.2023 13:43:03

Highest Band Edge / 1RB

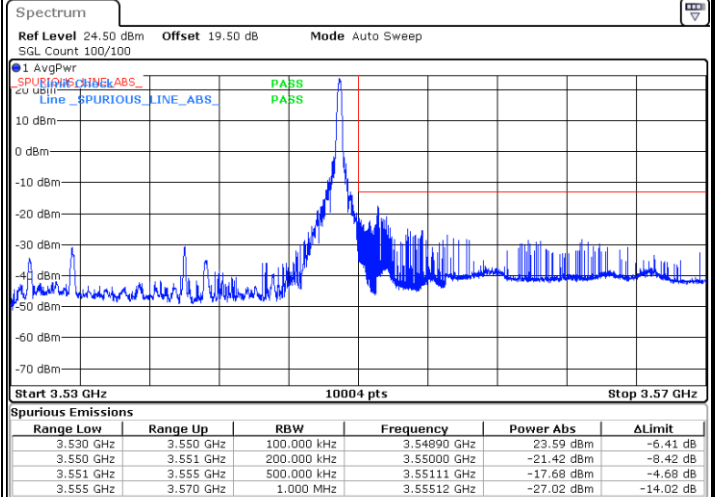

Date: 31.MAY.2023 14:00:12

Lowest Band Edge / Full RB

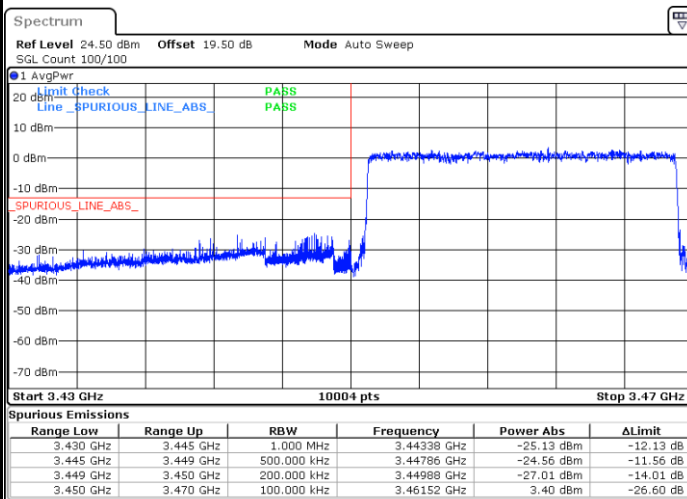

Date: 31.MAY.2023 13:55:58

Highest Band Edge / Full RB

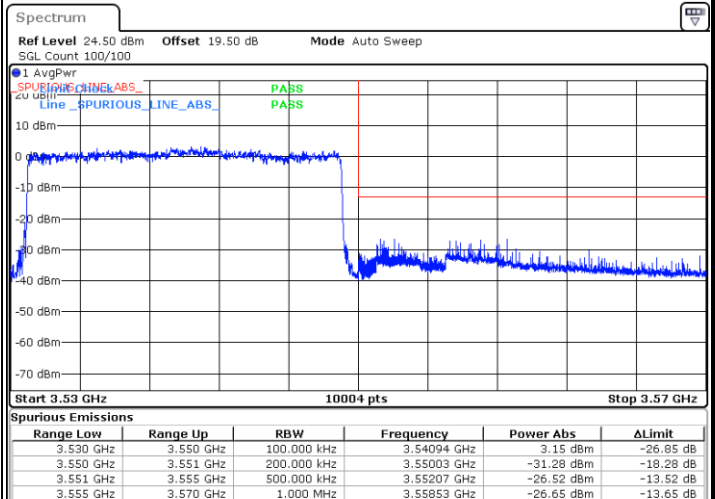

Date: 31.MAY.2023 13:58:04



LTE Band 42 / 20MHz / 64QAM

Lowest Band Edge / 1 RB

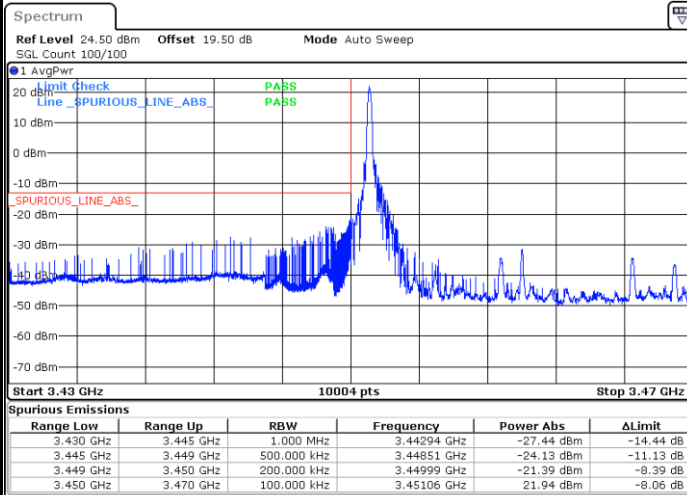

Date: 31.MAY.2023 13:44:49

Highest Band Edge / 1 RB

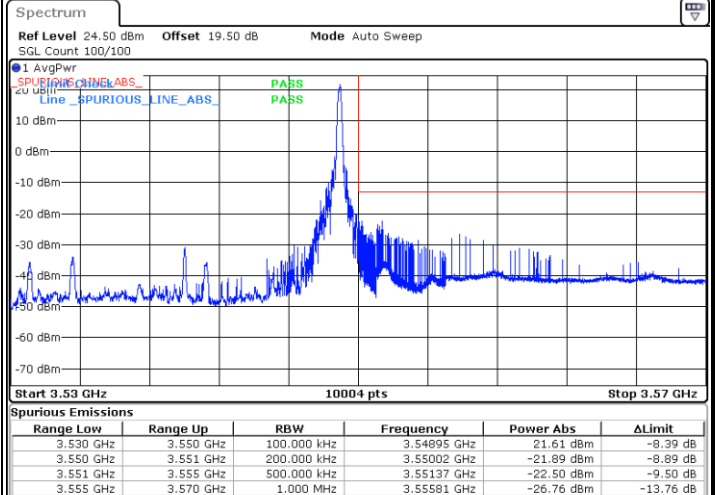

Date: 31.MAY.2023 14:00:38

Lowest Band Edge / Full RB

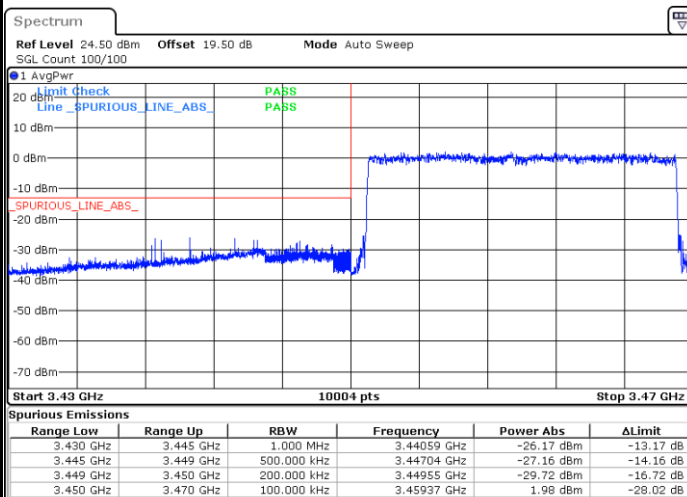

Date: 31.MAY.2023 13:56:34

Highest Band Edge / Full RB

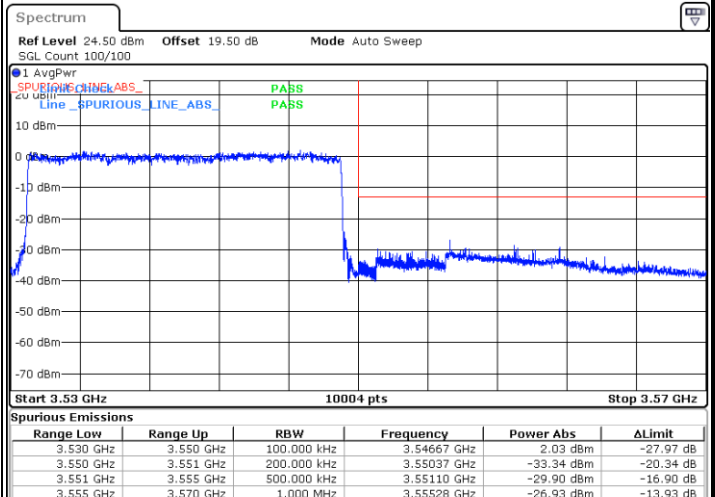

Date: 31.MAY.2023 13:57:33



Conducted Spurious Emission

LTE Band 42

Lowest Channel / QPSK_5MHz

Lowest Channel / QPSK_10MHz

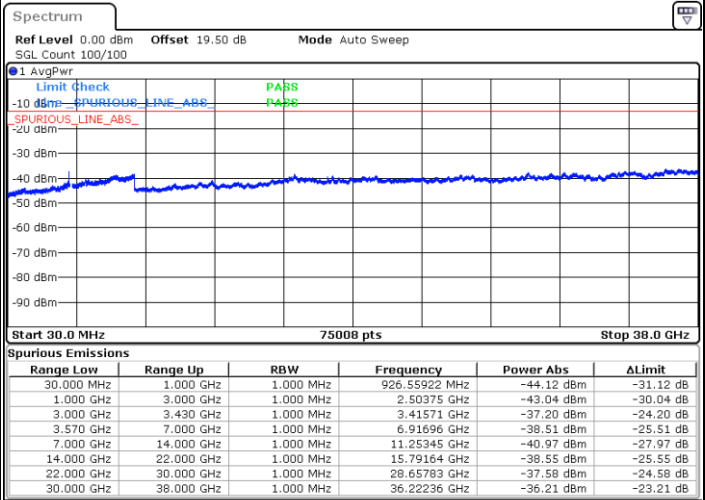
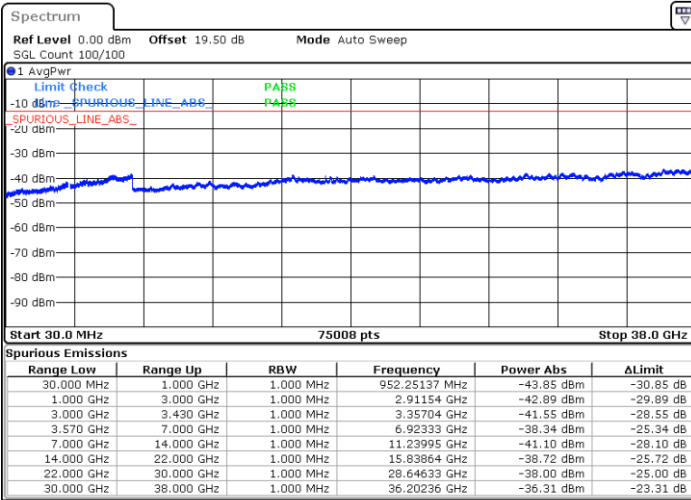

Date: 31.MAY.2023 11:13:33

Date: 31.MAY.2023 11:50:10

Middle Channel / QPSK_5MHz

Middle Channel / QPSK_10MHz

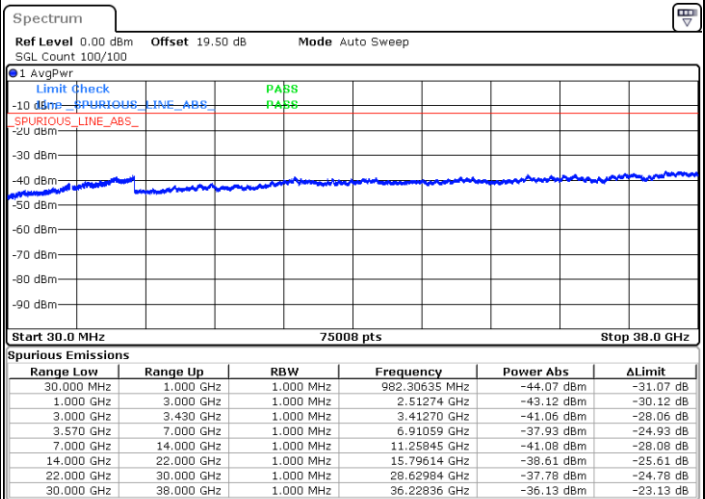
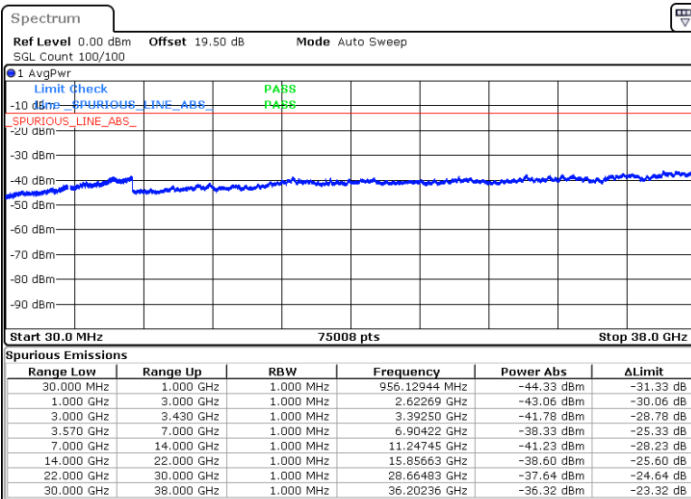

Date: 31.MAY.2023 11:28:26

Date: 31.MAY.2023 12:58:16

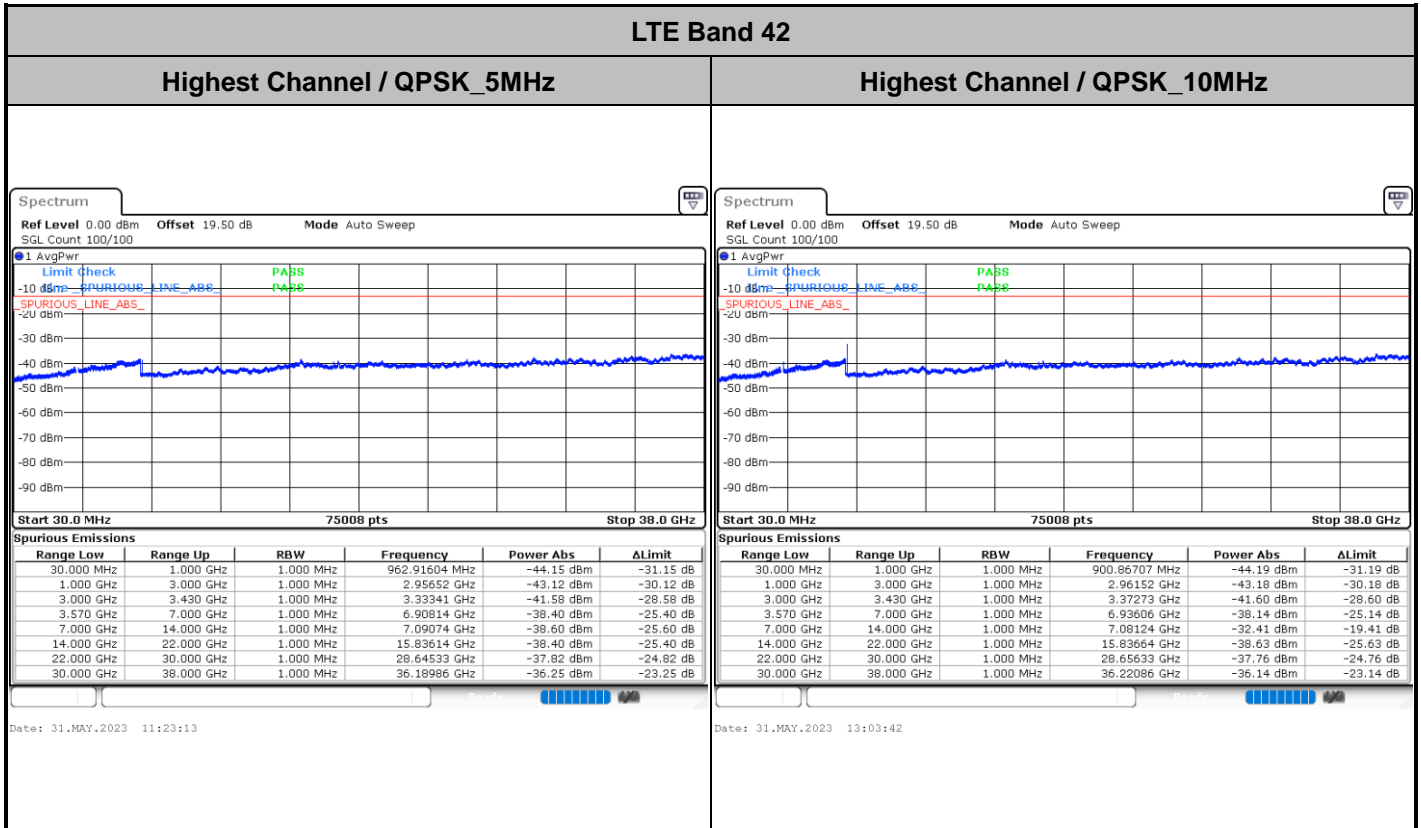



LTE Band 42

Lowest Channel / QPSK_15MHz

Lowest Channel / QPSK_20MHz

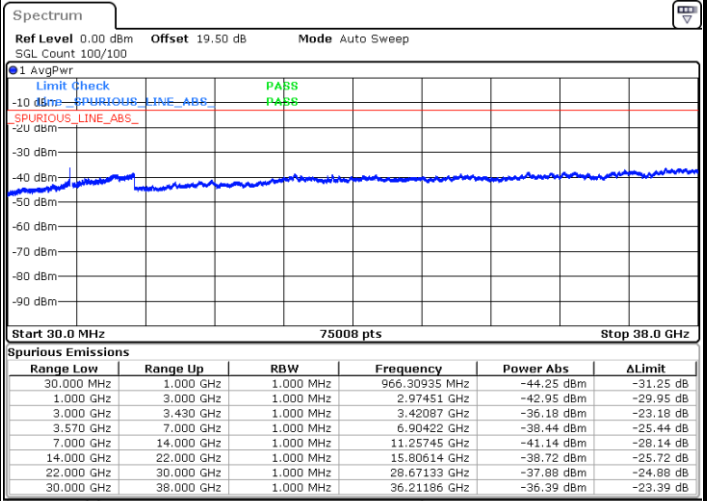
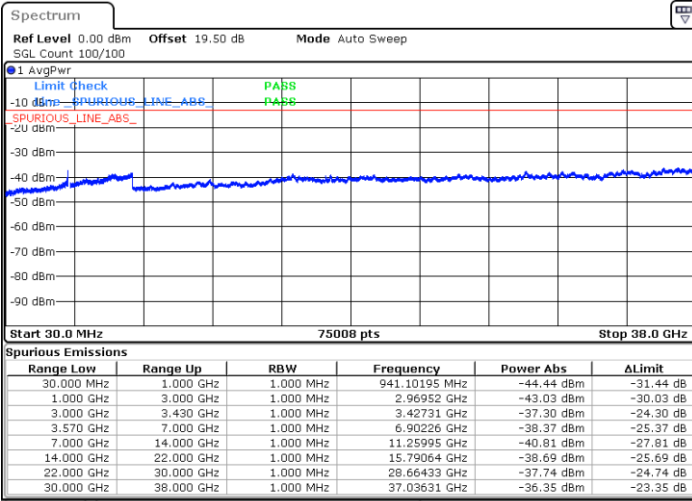

Date: 31.MAY.2023 13:14:46

Date: 31.MAY.2023 13:42:07

Middle Channel / QPSK_15MHz

Middle Channel / QPSK_20MHz

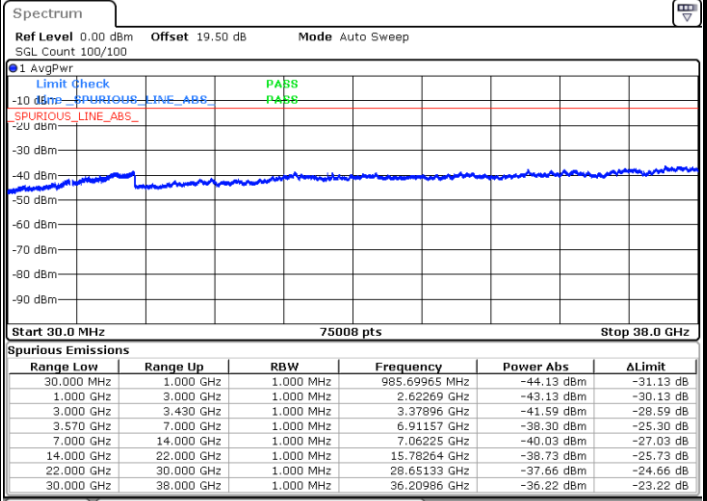
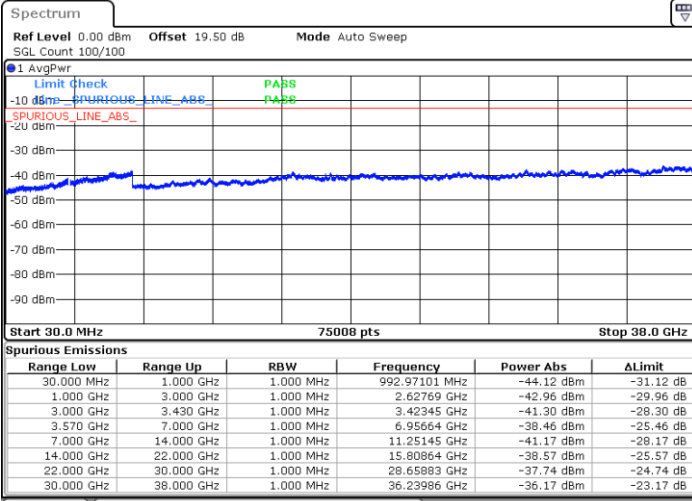

Date: 31.MAY.2023 13:22:04

Date: 31.MAY.2023 13:53:22

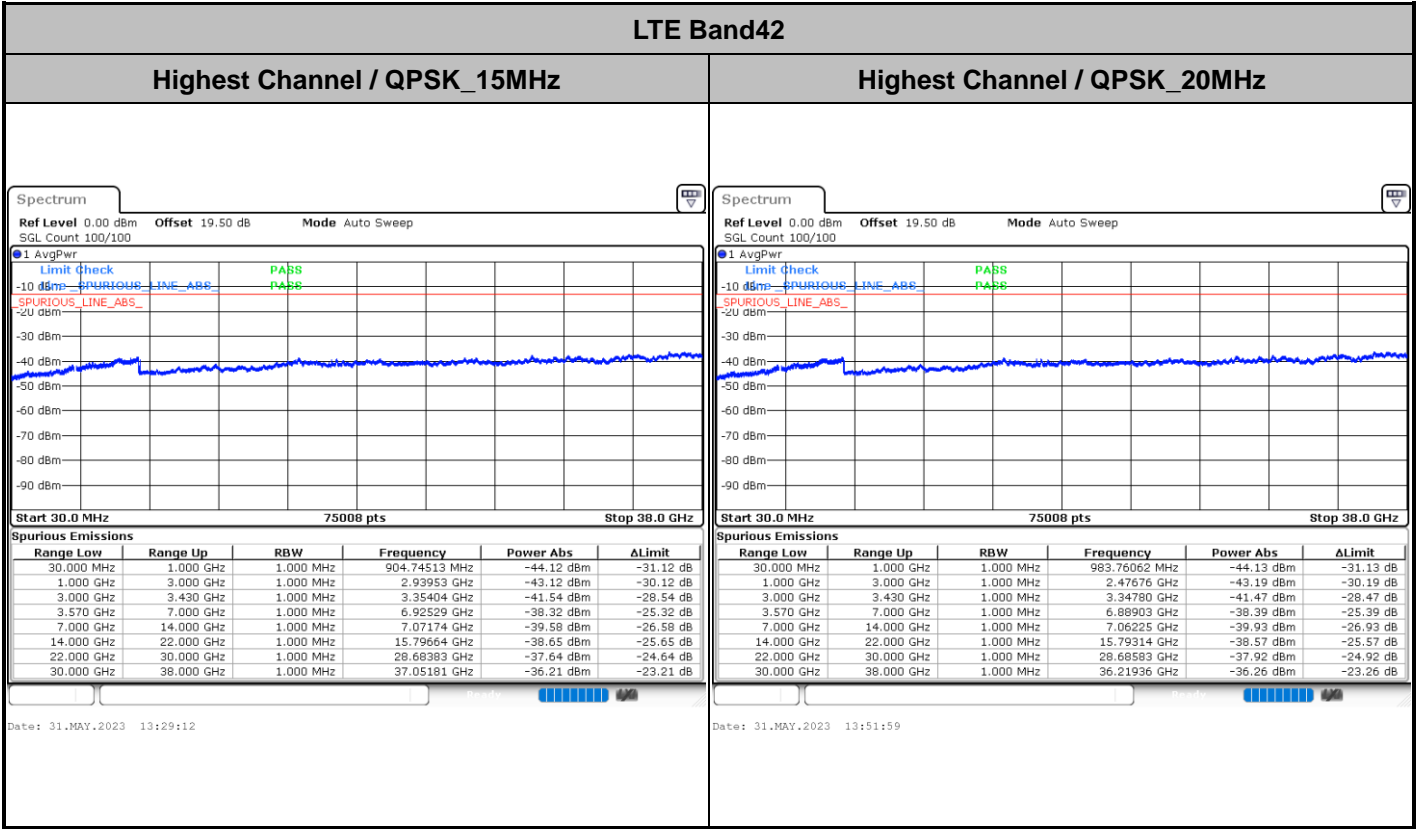

Frequency Stability

| Test Conditions | | LTE Band 42 (QPSK) / Middle Channel | Limit |
|------------------|-------------------|-------------------------------------|---------|
| Temperature (°C) | Voltage (Volt) | BW 10MHz | Note 2. |
| | | Deviation (ppm) | Result |
| 50 | Normal Voltage | 0.0007 | PASS |
| 40 | Normal Voltage | 0.0003 | |
| 30 | Normal Voltage | 0.0035 | |
| 20(Ref.) | Normal Voltage | 0.0000 | |
| 10 | Normal Voltage | 0.0033 | |
| 0 | Normal Voltage | 0.0006 | |
| -10 | Normal Voltage | 0.0032 | |
| -20 | Normal Voltage | 0.0001 | |
| -30 | Normal Voltage | 0.0001 | |
| 20 | Maximum Voltage | 0.0005 | |
| 20 | Normal Voltage | 0.0000 | |
| 20 | Battery End Point | 0.0005 | |

Note:

1. Normal Voltage =3.88 V. ; Battery End Point (BEP) =3.6 V. ; Maximum Voltage =4.47 V.
2. Note: The frequency fundamental emissions stay within the authorized frequency block.

Appendix B. Test Results of Radiated Test

Radiated Spurious Emission

| | | | |
|-----------------|------------|---------------------|---------|
| Test Engineer : | Shiwei Wen | Temperature : | 22~25°C |
| | | Relative Humidity : | 48~52% |

RSE pretest all the support Antennas, only the worst results are shown in the report.

| LTE Band 42 / 20MHz / QPSK / RB Size 1 Offset 0 (Ant.5) | | | | | | | | | |
|---|-------------------|--------------|---------------|-------------------|-------------------|--------------------|----------------------|-----------------------|--------------------|
| Channel | Frequency (MHz) | EIRP (dBm) | Limit (dBm) | Over Limit (dB) | SPA Reading (dBm) | S.G. Power (dBm) | TX Cable loss (dB) | TX Antenna Gain (dBi) | Polarization (H/V) |
| Middle | 6982.00 | -56.73 | -13 | -43.73 | -64.45 | -60.03 | 8.30 | 11.60 | H |
| | 10473.00 | -56.47 | -13 | -43.47 | -68.63 | -57.99 | 10.48 | 12.00 | H |
| | 13964.00 | -46.14 | -13 | -33.14 | -61.79 | -47.84 | 11.80 | 13.50 | H |
| | 6982.00 | -57.50 | -13 | -44.50 | -65.59 | -60.80 | 8.30 | 11.60 | V |
| | 10473.00 | -54.33 | -13 | -41.33 | -68.7 | -55.85 | 10.48 | 12.00 | V |
| | 13964.00 | -45.63 | -13 | -32.63 | -60.43 | -47.33 | 11.80 | 13.50 | V |

Remark: Spurious emissions within 30-1000MHz were found more than 20dB below limit line.