



# FCC RF Test Report

**APPLICANT** : Xiaomi Communications Co., Ltd.  
**EQUIPMENT** : Mobile Phone  
**BRAND NAME** : Xiaomi  
**MODEL NAME** : 23078PND5G  
**FCC ID** : 2AFZZND5G  
**STANDARD** : 47 CFR Part 2, Part 27 Subpart Q  
**CLASSIFICATION** : PCS Licensed Transmitter Held to Ear (PCE)  
**TEST DATE(S)** : May 24, 2023 ~ May 26, 2023

We, Sporton International Inc. (ShenZhen), would like to declare that the tested sample has been evaluated in accordance with the procedures given in ANSI C63.26-2015 and shown compliance with the applicable technical standards.

The test results in this report apply exclusively to the tested model / sample. Without written approval of Sporton International Inc. (ShenZhen), the test report shall not be reproduced except in full.

Jason Jia



Approved by: Jason Jia

**Sporton International Inc. (ShenZhen)**

**1/F, 2/F, Bldg 5, Shiling Industrial Zone, Xinwei Village, Xili, Nanshan, Shenzhen, 518055**

**People's Republic of China**



TABLE OF CONTENTS

REVISION HISTORY.....3
SUMMARY OF TEST RESULT .....4
1 GENERAL DESCRIPTION .....5
1.1 Applicant.....5
1.2 Manufacturer.....5
1.3 Product Feature of Equipment Under Test.....5
1.4 Product Specification of Equipment Under Test.....5
1.5 Modification of EUT .....6
1.6 Maximum EIRP Power and Emission Designator .....6
1.7 Testing Site.....7
1.8 Test Software.....8
1.9 Applied Standards .....8
2 TEST CONFIGURATION OF EQUIPMENT UNDER TEST .....9
2.1 Test Mode.....9
2.2 Connection Diagram of Test System.....10
2.3 Support Unit used in test configuration and system .....10
2.4 Measurement Results Explanation Example.....10
2.5 Frequency List of Low/Middle/High Channels .....11
3 CONDUCTED TEST ITEMS .....12
3.1 Measuring Instruments .....12
3.2 Test Setup .....12
3.3 Test Result of Conducted Test .....12
3.4 Conducted Output Power Measurement .....13
3.5 Peak-to-Average Ratio .....14
3.6 EIRP .....15
3.7 Occupied Bandwidth.....16
3.8 Conducted Band Edge Measurement .....17
3.9 Conducted Spurious Emission Measurement .....18
3.10 Frequency Stability Measurement .....19
4 RADIATED TEST ITEMS .....20
4.1 Measuring Instruments .....20
4.2 Test Setup .....20
4.3 Test Result of Radiated Test .....21
4.4 Radiated Spurious Emission Measurement .....22
5 LIST OF MEASURING EQUIPMENT .....23
6 MEASUREMENT UNCERTAINTY .....24
APPENDIX A. TEST RESULTS OF CONDUCTED TEST
APPENDIX B. TEST RESULTS OF RADIATED TEST
APPENDIX C. TEST SETUP PHOTOGRAPHS



## SUMMARY OF TEST RESULT

Report Section	FCC Rule	Description	Limit	Result	Remark
3.4	§2.1046	Conducted Output Power	—	Report Only	-
3.5	§27.50 (k)(4)	Peak-to-Average Ratio	<13dB	PASS	
3.6	§27.50 (k)(3)	EIRP	EIRP < 1W (30dBm)	PASS	-
3.7	§2.1049	Occupied Bandwidth	—	Report Only	-
3.8	§2.1051 §27.53 (n)(2)	Conducted Band Edge Measurement	-13dBm/MHz	PASS	-
3.9	§2.1051 §27.53 (n)(2)	Conducted Spurious Emission	-13dBm/MHz	PASS	-
3.10	§2.1055 §27.54	Frequency Stability Temperature & Voltage	Within the band	PASS	-
4.4	§2.1053 §27.53 (n)(2)	Radiated Spurious Emission	-13dBm/MHz	PASS	Under limit 31.62 dB at 10344.00 MHz

**Conformity Assessment Condition:**

1. The test results (PASS/FAIL) with all measurement uncertainty excluded are presented against the regulation limits or in accordance with the requirements stipulated by the applicant/manufacture who shall bear all the risks of non-compliance that may potentially occur if measurement uncertainty is taken into account.
2. The measurement uncertainty please refer to each test result in the section "Measurement Uncertainty"

**Disclaimer:**

The product specifications of the EUT presented in the test report that may affect the test assessments are declared by the manufacturer who shall take full responsibility for the authenticity.

# 1 General Description

## 1.1 Applicant

**Xiaomi Communications Co., Ltd.**

#019, 9th Floor, Building 6, 33 Xi'erqi Middle Road, Haidian District, Beijing, China, 100085

## 1.2 Manufacturer

**Xiaomi Communications Co., Ltd.**

#019, 9th Floor, Building 6, 33 Xi'erqi Middle Road, Haidian District, Beijing, China, 100085

## 1.3 Product Feature of Equipment Under Test

Product Feature	
Equipment	Mobile Phone
Brand Name	Xiaomi
Model Name	23078PND5G
FCC ID	2AFZZND5G
IMEI Code	Conducted: 861585060042882/861585060042890 Radiation: 861585060042627/861585060042635
HW Version	P2.0
SW Version	MIUI 14
EUT Stage	Identical Prototype

## 1.4 Product Specification of Equipment Under Test

Product Feature	
Tx/Rx Frequency	5G NR n77/n78: 3450 MHz ~ 3550 MHz
SCS	30kHz
Bandwidth	n77/n78: 10MHz / 15MHz / 20MHz / 25MHz / 30MHz / 40MHz / 50MHz / 60MHz / 70MHz / 80MHz / 90MHz / 100MHz
Antenna Gain	<b>&lt;Ant. 1&gt;</b> 5G NR n77: -7.00 dBi 5G NR n78: -7.00 dBi <b>&lt;Ant. 5&gt;</b> 5G NR n77: -0.26 dBi 5G NR n78: -0.67 dBi <b>&lt;Ant. 6&gt;</b> 5G NR n77: -1.00 dBi 5G NR n78: -1.00 dBi <b>&lt;Ant. 7&gt;</b> 5G NR n77: -6.10 dBi 5G NR n78: -6.10 dBi
Type of Modulation	CP-OFDM: QPSK / 16QAM / 64QAM / 256QAM DFT-s-OFDM: PI/2 BPSK / QPSK / 16QAM / 64QAM / 256QAM

**Remark:**

1. The maximum EIRP is calculated from max output power and max antenna gain, only the maximum EIRP of Ant.5 for 5G NR n77/n78 are shown in the report.
2. 5G NR n77/n78 supports SA mode and n78 supports NSA mode. According to the maximum power between SA and NSA mode, SA covers NSA mode for n78 and 5G NR n78 covers n77.
3. The device supports HPUE mode for 5G NR n77/n78.
4. All the supported EN-DC combinations are verified conducted power, only the EN-DC combination with highest power are shown in the report.
5. The EN-DC mode combination could be referred to the product spec.

### 1.5 Modification of EUT

No modifications are made to the EUT during all test items.

### 1.6 Maximum EIRP Power and Emission Designator

5G NR n77		PI/2 BPSK / QPSK		16QAM/64QAM/256QAM	
BW (MHz)	Frequency Range (MHz)	Maximum EIRP(W)	Emission Designator (99%OBW)	Maximum EIRP(W)	Emission Designator (99%OBW)
10	3455.01 ~ 3544.98	0.3192	8M56G7D	0.2438	8M58W7D
15	3457.50 ~ 3542.49	0.3192	13M6G7D	0.2455	13M6W7D
20	3460.02 ~ 3540.00	0.3170	18M2G7D	0.2460	18M2W7D
25	3462.51 ~ 3537.48	0.3126	23M2G7D	0.2421	23M2W7D
30	3465.00 ~ 3534.99	0.3083	27M8G7D	0.2449	27M9W7D
40	3470.01 ~ 3529.98	0.3141	37M7G7D	0.2432	37M8W7D
50	3475.02 ~ 3525.00	0.3133	47M3G7D	0.2449	47M4W7D
60	3480.00 ~ 3519.99	0.3155	57M6G7D	0.2455	57M9W7D
70	3485.01 ~ 3514.98	0.2972	67M4G7D	0.2312	67M6W7D
80	3490.02 ~ 3510.00	0.2972	77M3G7D	0.2355	77M4W7D
90	3495.00 ~ 3504.99	0.2972	87M4G7D	0.2323	87M5W7D
100	3500.01	0.3199	97M4G7D	0.2483	97M5W7D

5G NR n78		PI/2 BPSK / QPSK		16QAM/64QAM/256QAM	
BW (MHz)	Frequency Range (MHz)	Maximum EIRP(W)	Emission Designator (99%OBW)	Maximum EIRP(W)	Emission Designator (99%OBW)
10	3455.01 ~ 3544.98	0.3597	8M56G7D	0.2871	8M58W7D
15	3457.50 ~ 3542.49	0.3556	13M6G7D	0.2818	13M6W7D
20	3460.02 ~ 3540.00	0.3614	18M2G7D	0.2884	18M2W7D
25	3462.51 ~ 3537.48	0.3581	23M2G7D	0.2897	23M2W7D
30	3465.00 ~ 3534.99	0.3614	27M8G7D	0.3020	27M9W7D
40	3470.01 ~ 3529.98	0.3606	37M7G7D	0.3069	37M8W7D
50	3475.02 ~ 3525.00	0.3622	47M3G7D	0.2938	47M4W7D
60	3480.00 ~ 3519.99	0.3606	57M6G7D	0.2938	57M9W7D
70	3485.01 ~ 3514.98	0.3573	67M4G7D	0.2793	67M6W7D
80	3490.02 ~ 3510.00	0.3639	77M3G7D	0.2818	77M4W7D
90	3495.00 ~ 3504.99	0.3648	87M4G7D	0.2818	87M5W7D
100	3500.01	0.3707	97M4G7D	0.2818	97M5W7D

**Note:**

1. 5G NR Band n77 overlaps the entire frequency range of Band n78, and n78 power > n77 power, therefore the conducted test results of n78 provided in this report cover n77.
2. All modulations have been tested, and only the worst test results of PSK & QAM are shown in the report.

### 1.7 Testing Site

Sporton International Inc. (Kunshan) is accredited to ISO/IEC 17025:2017 by American Association for Laboratory Accreditation with Certificate Number 5145.02.

<b>Test Firm</b>	Sporton International Inc. (Kunshan)		
<b>Test Site Location</b>	No. 1098, Pengxi North Road, Kunshan Economic Development Zone Jiangsu Province 215300 People's Republic of China TEL : +86-512-57900158		
<b>Test Site No.</b>	<b>Sporton Site No.</b>	<b>FCC Designation No.</b>	<b>FCC Test Firm Registration No.</b>
	TH01-KS	CN1257	314309

Note: Test data subcontracted: Test case of Conducted in section 3 of this report

Sporton International Inc. (ShenZhen) is accredited to ISO/IEC 17025:2017 by American Association for Laboratory Accreditation with Certificate Number 5145.01.

<b>Test Firm</b>	Sporton International Inc. (ShenZhen)		
<b>Test Site Location</b>	101, 1st Floor, Block B, Building 1, No. 2, Tengfeng 4th Road, Fenghuang Community, Fuyong Street, Baoan District, Shenzhen City Guangdong Province China 518103 TEL: +86-755-33202398		
<b>Test Site No.</b>	<b>Sporton Site No.</b>	<b>FCC Designation No.</b>	<b>FCC Test Firm Registration No.</b>
	03CH01-SZ	CN1256	421272

### 1.8 Test Software

Item	Site	Manufacturer	Name	Version
1.	03CH01-SZ	AUDIX	E3	6.2009-8-24

### 1.9 Applied Standards

According to the specifications of the manufacturer, the EUT must comply with the requirements of the following standards:

- ♦ 47 CFR Part 2, Part 27 Subpart Q
- ♦ ANSI C63.26-2015
- ♦ FCC KDB 971168 Power Meas License Digital Systems D01 v03r01
- ♦ FCC KDB 412172 D01 Determining ERP and EIRP v01r01

**Remark:**

1. All test items were verified and recorded according to the standards and without any deviation during the test.
2. This EUT has also been tested and complied with the requirements of FCC Part 15, Subpart B, recorded in a separate test report.



## 2 Test Configuration of Equipment Under Test

### 2.1 Test Mode

Antenna port conducted and radiated test items listed below are performed according to KDB 971168 D01 Power Meas. License Digital Systems v03r01 with maximum output power.

For radiated measurement, pre-scanned flip open and close state in three orthogonal panels X, Y, Z.

The worst cases (Z plane) were recorded in this report.

Test Cases	Band	Bandwidth (MHz)	Modulation	RB #	Test Channel
		eg. 5M, 10M, 15M, 20M	eg. PI/2 BPSK, QPSK, 16QAM, 64QAM, 256QAM	1RB, Partial RB, Full RB	L/M/H
Max. Output Power	5G n77	10M, 15M, 20M, 25M, 30M, 40M, 50M, 60M, 70M, 80M, 90M, 100M	All Modulations	1RB, Full RB	L, M, H
	5G n78	10M, 15M, 20M, 25M, 30M, 40M, 50M, 60M, 70M, 80M, 90M, 100M	All Modulations	1RB, Full RB	L, M, H
Peak-to-Average Ratio	5G n78	100M	PI/2 BPSK, QPSK	1RB, Full RB	L, M, H
E.I.R.P	5G n77	10M, 15M, 20M, 25M, 30M, 40M, 50M, 60M, 70M, 80M, 90M, 100M	All Modulations	1RB, Full RB	L, M, H
	5G n78	10M, 15M, 20M, 25M, 30M, 40M, 50M, 60M, 70M, 80M, 90M, 100M	All Modulations	1RB, Full RB	L, M, H
26dB and 99% Bandwidth	5G n78	10M, 15M, 20M, 25M, 30M, 40M, 50M, 60M, 70M, 80M, 90M, 100M	All Modulations	Full RB	M
Conducted Band Edge	5G n78	10M, 50M, 100M	PI/2 BPSK, QPSK	1RB, Full RB	L, H
Conducted Spurious Emission	5G n78	10M, 50M, 100M	PI/2 BPSK, QPSK	1RB	L, M, H
Frequency Stability	5G n78	10M	QPSK	Full RB	M
Radiated Spurious Emission	5G n77	Worst case from maximum power			M
	5G n78	Worst case from maximum power			M

**Note:**

- The device is investigated from 30MHz to 10 times of fundamental signal for radiated spurious emission test under different RB size/offset and modulations in exploratory test. Subsequently, only the worst case emissions are reported.
- Frequency Stability: Normal Voltage = 3.88V; Low Voltage =3.60V; High Voltage =4.47V.
- All test items are based on engineering evaluation.

## 2.2 Connection Diagram of Test System

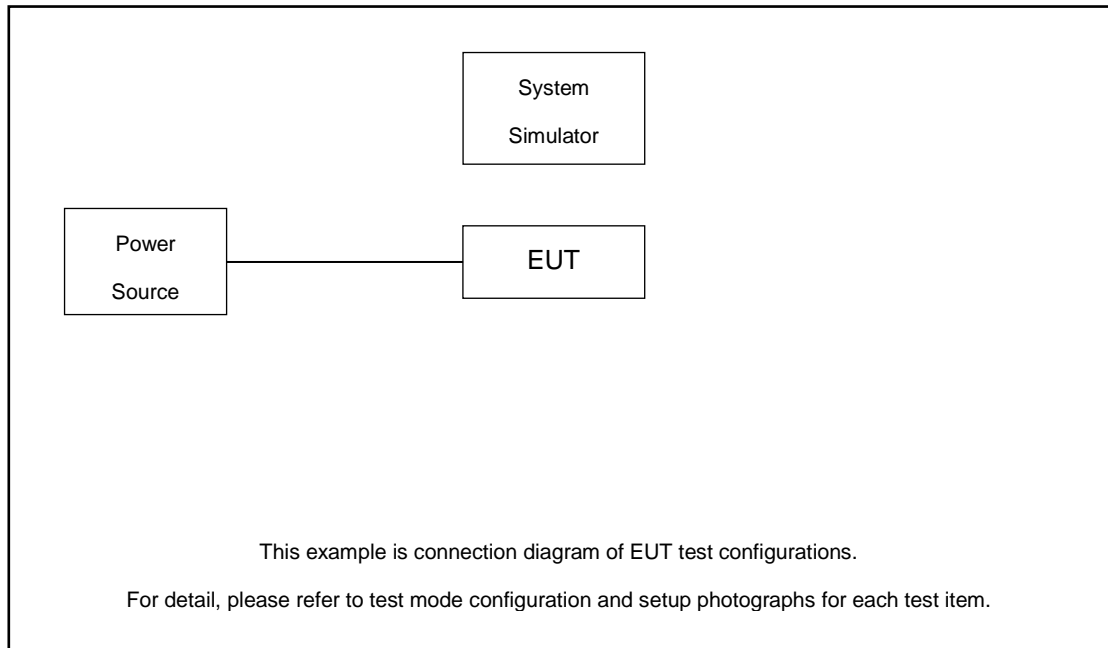

## 2.3 Support Unit used in test configuration and system

Item	Equipment	Trade Name	Model No.	FCC ID	Data Cable	Power Cord
1.	Power Supply	GWINSTEK	PSS-2002	N/A	N/A	Unshielded, 1.8 m
2.	NR Base Station	Anritsu	MT8000A	N/A	N/A	Unshielded, 1.8 m

## 2.4 Measurement Results Explanation Example

### For all conducted test items:

The offset level is set in the spectrum analyzer to compensate the RF cable loss and attenuator factor between RF conducted output port and spectrum analyzer. With the offset compensation, the spectrum analyzer reading level will be exactly the RF output level.

The spectrum analyzer offset is derived from RF cable loss and attenuator factor.

*Offset = RF cable loss + attenuator factor.*

The following shows an offset computation example with RF cable loss 6.5 dB and a 20dB attenuator.

Example :

$$\begin{aligned} \text{Offset(dB)} &= \text{RF cable loss(dB)} + \text{attenuator factor(dB)} \\ &= 6.5 + 20 = 26.5 \text{ (dB)} \end{aligned}$$

## 2.5 Frequency List of Low/Middle/High Channels

5G n77/n78 Channel and Frequency List				
BW [MHz]	Channel/Frequency(MHz)	Lowest	Middle	Highest
100	Channel	-	633334	-
	Frequency	-	3500.01	-
90	Channel	633000	633334	633666
	Frequency	3495	3500.01	3504.99
80	Channel	632668	633334	634000
	Frequency	3490.02	3500.01	3510
70	Channel	632334	633334	634332
	Frequency	3485.01	3500.01	3514.98
60	Channel	632000	633334	634666
	Frequency	3480	3500.01	3519.99
50	Channel	631668	633334	635000
	Frequency	3475.02	3500.01	3525
40	Channel	631334	633334	635332
	Frequency	3470.01	3500.01	3529.98
30	Channel	631000	633334	635666
	Frequency	3465	3500.01	3534.99
25	Channel	630834	633334	635832
	Frequency	3462.51	3500.01	3537.48
20	Channel	630668	633334	636000
	Frequency	3460.02	3500.01	3540
15	Channel	630500	633334	636166
	Frequency	3457.5	3500.01	3542.49
10	Channel	630334	633334	636332
	Frequency	3455.01	3500.01	3544.98

### 3 Conducted Test Items

#### 3.1 Measuring Instruments

See list of measuring instruments of this test report.

#### 3.2 Test Setup

##### 3.2.1 Conducted Output Power

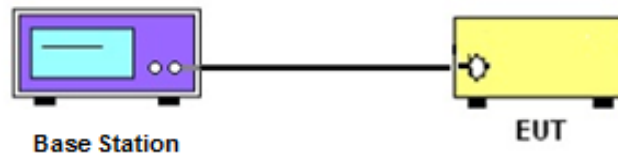

##### 3.2.2 Peak-to-Average Ratio, Occupied / 26dB Bandwidth, Band-Edge and Conducted Spurious Emission

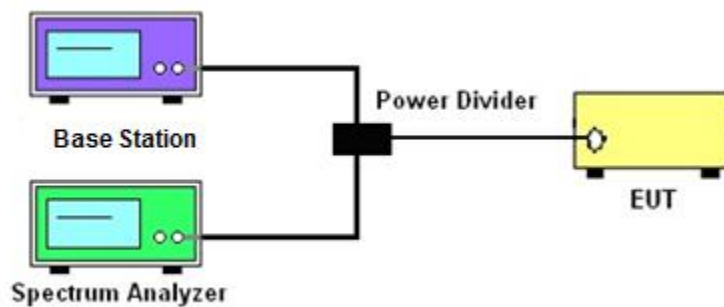

##### 3.2.3 Frequency Stability

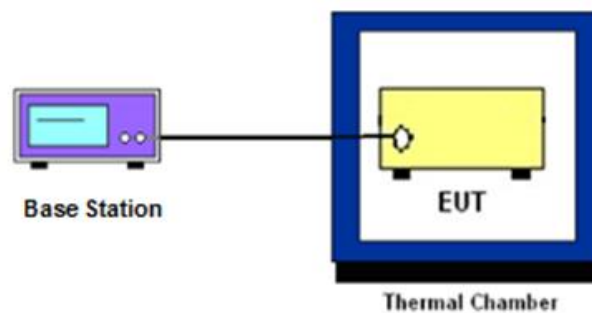

### 3.3 Test Result of Conducted Test

Please refer to Appendix A.



## **3.4 Conducted Output Power Measurement**

### **3.4.1 Description of the Conducted Output Power Measurement**

A base station simulator was used to establish communication with the EUT. Its parameters were set to transmit the maximum power on the EUT. The measured power in the radio frequency on the transmitter output terminals shall be reported.

### **3.4.2 Test Procedures**

1. The testing follows ANSI C63.26 Section 5.2
2. The transmitter output port was connected to the system simulator.
3. Set EUT at maximum power through the system simulator.
4. Select lowest, middle, and highest channels for each band and different modulation.
5. Measure and record the power level from the system simulator.

## 3.5 Peak-to-Average Ratio

### 3.5.1 Description of the PAR Measurement

Power Complementary Cumulative Distribution Function (CCDF) curves provide a means for characterizing the power peaks of a digitally modulated signal on a statistical basis. A CCDF curve depicts the probability of the peak signal amplitude exceeding the average power level. Most contemporary measurement instrumentation include the capability to produce CCDF curves for an input signal provided that the instrument's resolution bandwidth can be set wide enough to accommodate the entire input signal bandwidth. In measuring transmissions in this band using an average power technique, the peak-to-average ratio (PAR) of the transmission may not exceed 13 dB.

### 3.5.2 Test Procedures

1. The testing follows ANSI C63.26 Section 5.2.3.4 (CCDF).
2. The EUT was connected to spectrum and system simulator via a power divider.
3. Set the CCDF (Complementary Cumulative Distribution Function) option in spectrum analyzer.
4. The highest RF powers were measured and recorded the maximum PAPR level associated with a probability of 0.1 %.
5. Record the deviation as Peak to Average Ratio.

## 3.6 EIRP

### 3.6.1 Description of EIRP Limit

#### § 27.50 (k)(3)

Mobile devices are limited to 1Watt (30 dBm) EIRP. Mobile devices operating in these bands must employ a means for limiting power to the minimum necessary for successful communications

### 3.6.2 Test Procedures

1. According to KDB 412172 D01 Power Approach,
2.  $EIRP = P_T + G_T - L_C$ ,  $ERP = EIRP - 2.15$ , where  
 $P_T$  = transmitter output power in dBm  
 $G_T$  = gain of the transmitting antenna in dBi  
 $L_C$  = signal attenuation in the connecting cable between the transmitter and antenna in dB

## 3.7 Occupied Bandwidth

### 3.7.1 Description of Occupied Bandwidth Measurement

The occupied bandwidth is the width of a frequency band such that, below the lower and above the upper frequency limits, the mean powers emitted are each equal to a specified percentage 0.5% of the total mean transmitted power.

The 26 dB emission bandwidth is defined as the frequency range between two points, one above and one below the carrier frequency, at which the spectral density of the emission is attenuated 26 dB below the maximum in-band spectral density of the modulated signal. Spectral density (power per unit bandwidth) is to be measured with a detector of resolution bandwidth equal to approximately 1.0% of the emission bandwidth.

### 3.7.2 Test Procedures

1. The testing follows ANSI C63.26 Section 5.4
2. The EUT was connected to spectrum analyzer and system simulator via a power divider.
3. The spectrum analyzer center frequency is set to the nominal EUT channel center frequency. The span range for the spectrum analyzer shall be between two and five times the anticipated OBW.
4. The nominal resolution bandwidth (RBW) shall be in the range of 1 to 5 % of the anticipated OBW, and the VBW shall be at least 3 times the RBW.
5. Set the detection mode to peak, and the trace mode to max hold.
6. Determine the reference value: Set the EUT to transmit a modulated signal. Allow the trace to stabilize. Set the spectrum analyzer marker to the highest level of the displayed trace.  
(this is the reference value)
7. Determine the “-26 dB down amplitude” as equal to (Reference Value – X).
8. Place two markers, one at the lowest and the other at the highest frequency of the envelope of the spectral display such that each marker is at or slightly below the “-X dB down amplitude” determined in step 6. If a marker is below this “-X dB down amplitude” value it shall be placed as close as possible to this value. The OBW is the positive frequency difference between the two markers.
9. Use the 99 % power bandwidth function of the spectrum analyzer and report the measured bandwidth.





## 3.8 Conducted Band Edge Measurement

### 3.8.1 Description of Conducted Band Edge Measurement

#### § 27.53 (n)(2)

For mobile operations in the 3450-3550 MHz band, the conducted power of any emission outside the licensee's authorized bandwidth shall not exceed  $-13$  dBm/MHz.

Compliance with this paragraph is based on the use of measurement instrumentation employing a resolution bandwidth of 1 megahertz or greater. However, in the 1 megahertz bands immediately outside and adjacent to the licensee's frequency block, a resolution bandwidth of at least one percent of the emission bandwidth of the fundamental emission of the transmitter may be employed, but limited to a maximum of 200 kHz. In the bands between 1 and 5 MHz removed from the licensee's frequency block, the minimum resolution bandwidth for the measurement shall be 500 kHz.

### 3.8.2 Test Procedures

1. The testing follows ANSI C63.26 section 5.7
2. The EUT was connected to spectrum analyzer and system simulator via a power divider.
3. The band edges of low and high channels for the highest RF powers were measured.
4. Set RBW  $\geq$  1% EBW but limited to a maximum of 200 kHz in the 1MHz band immediately outside and adjacent to the band edge.
5. Beyond the 1 MHz and 5 MHz removed from the band edge, set RBW  $\geq$  500KHz.
6. Beyond the 5 MHz removed from the band edge, set RBW = 1MHz.
7. Set spectrum analyzer with RMS detector.
8. The RF fundamental frequency should be excluded against the limit line in the operating frequency band.
9. Checked that all the results comply with the emission limit line.

## 3.9 Conducted Spurious Emission Measurement

### 3.9.1 Description of Conducted Spurious Emission Measurement

The power of any emission outside of the authorized operating frequency ranges shall not exceed -13 dBm/MHz.

It is measured by means of a calibrated spectrum analyzer and scanned from 9 kHz up to a frequency including its 10<sup>th</sup> harmonic.

### 3.9.2 Test Procedures

1. The testing follows ANSI C63.26 section 5.7
2. The EUT was connected to spectrum analyzer and system simulator via a power divider.
3. The RF output of EUT was connected to the spectrum analyzer by RF cable and attenuator. The path loss was compensated to the results for each measurement.
4. The middle channel for the highest RF power within the transmitting frequency was measured.
5. The conducted spurious emission for the whole frequency range was taken.
6. Make the measurement with the spectrum analyzer's RBW = 1MHz, VBW = 3MHz.
7. Set spectrum analyzer with RMS detector.
8. Taking the record of maximum spurious emission.
9. The RF fundamental frequency should be excluded against the limit line in the operating frequency band.
10. Checked that all the results comply with the emission limit line.

## 3.10 Frequency Stability Measurement

### 3.10.1 Description of Frequency Stability Measurement

The frequency stability shall be measured by variation of ambient temperature and variation of primary supply voltage to ensure that the fundamental emission stays within the authorized frequency block.

### 3.10.2 Test Procedures for Temperature Variation

1. The testing follows ANSI C63.26 section 5.6.4
2. The EUT was set up in the thermal chamber and connected with the system simulator.
3. With power OFF, the temperature was decreased to  $-30^{\circ}\text{C}$  and the EUT was stabilized before testing. Power was applied and the maximum change in frequency was recorded within one minute.
4. With power OFF, the temperature was raised in  $10^{\circ}\text{C}$  step up to  $50^{\circ}\text{C}$ . The EUT was stabilized at each step for at least half an hour. Power was applied and the maximum frequency change was recorded within one minute.

### 3.10.3 Test Procedures for Voltage Variation

1. The testing follows ANSI C63.26 section 5.6.5.
2. The EUT was placed in a temperature chamber at  $20\pm 5^{\circ}\text{C}$  and connected with the system simulator.
3. The power supply voltage to the EUT was varied from 85% to 115% of the nominal value for other than hand carried battery equipment.
4. For hand carried, battery powered equipment, reduce the primary ac or dc supply voltage to the battery operating end point, which shall be specified by the manufacturer.
5. The variation in frequency was measured for the worst case.

## 4 Radiated Test Items

### 4.1 Measuring Instruments

See list of measuring instruments of this test report.

### 4.2 Test Setup

#### 4.2.1 For radiated test below 30MHz



#### 4.2.2 For radiated test from 30MHz to 1GHz

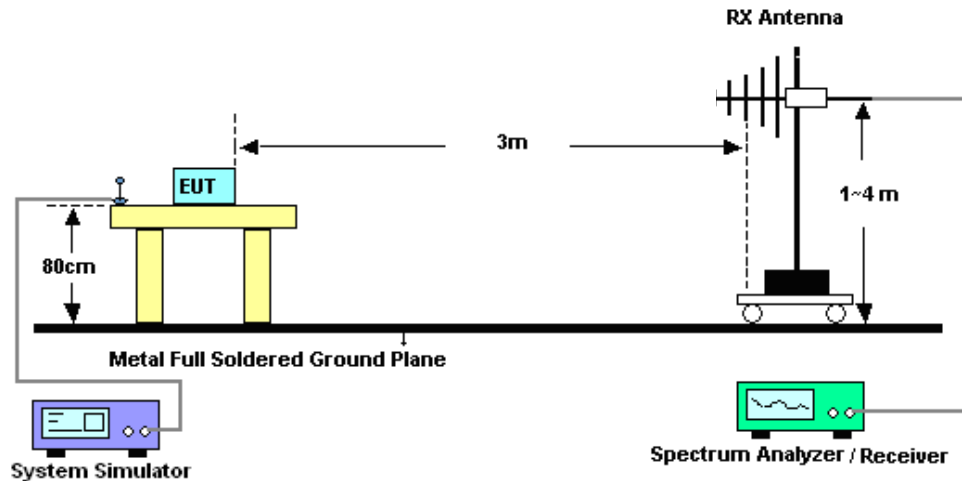

#### 4.2.3 For radiated test above 1GHz



### 4.3 Test Result of Radiated Test

The low frequency, which started from 9 kHz to 30MHz, was pre-scanned and the result which was 20dB lower than the limit line was not reported.

Please refer to Appendix B.

## 4.4 Radiated Spurious Emission Measurement

### 4.4.1 Description of Radiated Spurious Emission

The radiated spurious emission was measured by substitution method according to ANSI/TIA-603-E. The power of any emission outside of the authorized operating frequency ranges shall not exceed -13 dBm/MHz.

The spectrum is scanned from 30 MHz up to a frequency including its 10th harmonic.

### 4.4.2 Test Procedures

1. The testing follows ANSI C63.26 Section 5.5
2. The EUT was placed on a turntable with 0.8 meter height for frequency below 1GHz and 1.5 meter height for frequency above 1GHz respectively above ground.
3. The EUT was set 3 meters from the receiving antenna mounted on the antenna tower.
4. The table was rotated 360 degrees to determine the position of the highest spurious emission.
5. The height of the receiving antenna is varied between 1m to 4m to search the maximum spurious emission for both horizontal and vertical polarizations.
6. During the measurement, the system simulator parameters were set to force the EUT transmitting at maximum output power.
7. Make the measurement with the spectrum analyzer's RBW = 1MHz, VBW = 3MHz, taking the record of maximum spurious emission.
8. A horn antenna was substituted in place of the EUT and was driven by a signal generator.
9. Tune the output power of signal generator to the same emission level with EUT maximum spurious emission.  
$$\text{EIRP (dBm)} = \text{S.G. Power} - \text{Tx Cable Loss} + \text{Tx Antenna Gain}$$
$$\text{ERP (dBm)} = \text{EIRP} - 2.15$$
10. The RF fundamental frequency should be excluded against the limit line in the operating frequency band.



## 5 List of Measuring Equipment

Instrument	Manufacturer	Model No.	Serial No.	Characteristics	Calibration Date	Test Date	Due Date	Remark
Spectrum Analyzer	R&S	FSV40	101078	10Hz~40GHz	Apr. 06, 2023	May 26, 2023	Apr. 05, 2024	Conducted (TH01-SZ)
Power Divider	TOJOIN	PS-2SM-04 265	60.06.020.007 7	0.4GHz~26.5GHz	Dec. 25, 2022	May 26, 2023	Dec. 24, 2023	Conducted (TH01-SZ)
Thermal Chamber	Ten Billion Hongzhangroup	LP-150U	H2014081803	-40~+150°C	Jul. 07, 2022	May 26, 2023	Jul. 06, 2023	Conducted (TH01-SZ)
EMI Test Receiver&SA	Agilent	N9038A	MY52260185	20Hz~26.5GHz	Dec. 26, 2022	May 24, 2023	Dec. 25, 2023	Radiation (03CH01-SZ)
EXA Spectrum Analyzer	KEYSIGHT	N9010A	MY55150213	10Hz~44GHz	Jul. 07, 2022	May 24, 2023	Jul. 06, 2023	Radiation (03CH01-SZ)
Loop Antenna	R&S	HFH2-Z2	100354	9kHz~30MHz	Jul. 28, 2022	May 24, 2023	Jul. 27, 2024	Radiation (03CH01-SZ)
HF Amplifier	KEYSIGHT	83017A	MY53270105	0.5GHz~26.5Ghz	Oct. 19, 2022	May 24, 2023	Oct. 18, 2023	Radiation (03CH01-SZ)
Bilog Antenna	TeseQ	CBL6112D	35407	30MHz-2GHz	Sep. 28, 2021	May 24, 2023	Sep. 27, 2023	Radiation (03CH01-SZ)
Double Ridge Horn Antenna	ETS-Lindgren	3117	00119436	1GHz~18GHz	Jul. 07, 2022	May 24, 2023	Jul. 06, 2023	Radiation (03CH01-SZ)
SHF-EHF Horn	com-power	AH-840	101071	18Ghz-40GHz	Apr. 08,2023	May 24, 2023	Apr. 07,2024	Radiation (03CH01-SZ)
LF Amplifier	Burgeon	BPA-530	102209	0.01~3000Mhz	Apr. 04, 2023	May 24, 2023	Apr. 03, 2024	Radiation (03CH01-SZ)
HF Amplifier	MITEQ	AMF-7D-00 101800-30-1 0P-R	1943528	1GHz~18GHz	Oct. 19, 2022	May 24, 2023	Oct. 18, 2023	Radiation (03CH01-SZ)
HF Amplifier	MITEQ	TTA1840-35 -HG	1871923	18GHz~40GHz	Jul. 06, 2022	May 24, 2023	Jul. 05, 2023	Radiation (03CH01-SZ)
AC Power Source	Chroma	61601	61601000198 5	N/A	Nov. 10, 2022	May 24, 2023	Nov. 09, 2023	Radiation (03CH01-SZ)
Turn Table	EM	EM1000	N/A	0~360 degree	NCR	May 24, 2023	NCR	Radiation (03CH01-SZ)
Antenna Mast	EM	EM1000	N/A	1 m~4 m	NCR	May 24, 2023	NCR	Radiation (03CH01-SZ)

NCR: No Calibration Required

## 6 Measurement Uncertainty

The measurement uncertainties shown below were calculated in accordance with the requirements of ANSI 63.26-2015. All the measurement uncertainty value were shown with a coverage K=2 to indicate 95% level of confidence. The measurement data show herein meets or exceeds the CISPR measurement uncertainty values specified in CISPR 16-4-2 and can be compared directly to specified limit to determine compliance.

### Uncertainty of Conducted Measurement

Test Item	Uncertainty
Conducted Power	±1.34 dB
Conducted Emissions	±1.34 dB
Occupied Channel Bandwidth	±0.13 %

### Uncertainty of Radiated Emission Measurement (30 MHz ~ 1000 MHz)

Measuring Uncertainty for a Level of Confidence of 95% (U = 2Uc(y))	2.48dB
---	--------

### Uncertainty of Radiated Emission Measurement (1 GHz ~ 18 GHz)

Measuring Uncertainty for a Level of Confidence of 95% (U = 2Uc(y))	3.53dB
---	--------

### Uncertainty of Radiated Emission Measurement (18 GHz ~ 40 GHz)

Measuring Uncertainty for a Level of Confidence of 95% (U = 2Uc(y))	4.02dB
---	--------

----- THE END -----





## Appendix A. Test Results of Conducted Test

Test Engineer :	Smile Wang	Temperature :	22~23°C
		Relative Humidity :	40~42%

# FR1 N77-Ant 5

## Transmitter Conducted Output Power And EIRP, $(G_T - L_C) = -0.26\text{dBi}$

NR Band	SCS	BandWidth	Arfcn	Freq(MHz)	Modulation	RB	Conducted Power(dBm)	EIRP(dBm)	EIRP(W)
77	30	10	630334	3455.01	DFT-s-OFDM PI/2 BPSK	1@1	25.13	24.87	0.3069
77	30	10	630334	3455.01	DFT-s-OFDM QPSK	1@1	25.3	25.04	0.3192
77	30	10	630334	3455.01	DFT-s-OFDM 16 QAM	1@1	24.13	23.87	0.2438
77	30	10	633334	3500.01	DFT-s-OFDM PI/2 BPSK	1@1	25.1	24.84	0.3048
77	30	10	633334	3500.01	DFT-s-OFDM QPSK	1@1	25.16	24.9	0.3090
77	30	10	633334	3500.01	DFT-s-OFDM 16 QAM	1@1	24.09	23.83	0.2415
77	30	10	636332	3544.98	DFT-s-OFDM PI/2 BPSK	1@1	25.15	24.89	0.3083
77	30	10	636332	3544.98	DFT-s-OFDM QPSK	1@1	25.13	24.87	0.3069
77	30	10	636332	3544.98	DFT-s-OFDM 16 QAM	1@1	24.1	23.84	0.2421
77	30	15	630500	3457.5	DFT-s-OFDM PI/2 BPSK	1@1	25.16	24.9	0.3090
77	30	15	630500	3457.5	DFT-s-OFDM QPSK	1@1	25.22	24.96	0.3133
77	30	15	630500	3457.5	DFT-s-OFDM 16 QAM	1@1	24.16	23.9	0.2455
77	30	15	633334	3500.01	DFT-s-OFDM PI/2 BPSK	1@1	25.14	24.88	0.3076
77	30	15	633334	3500.01	DFT-s-OFDM QPSK	1@1	25.24	24.98	0.3148
77	30	15	633334	3500.01	DFT-s-OFDM 16 QAM	1@1	24.16	23.9	0.2455
77	30	15	636166	3542.49	DFT-s-OFDM PI/2 BPSK	1@1	25.15	24.89	0.3083
77	30	15	636166	3542.49	DFT-s-OFDM QPSK	1@1	25.3	25.04	0.3192
77	30	15	636166	3542.49	DFT-s-OFDM 16 QAM	1@1	24.15	23.89	0.2449
77	30	20	630668	3460.02	DFT-s-OFDM PI/2 BPSK	1@1	25.15	24.89	0.3083
77	30	20	630668	3460.02	DFT-s-OFDM QPSK	1@1	25.27	25.01	0.3170
77	30	20	630668	3460.02	DFT-s-OFDM 16 QAM	1@1	24.13	23.87	0.2438
77	30	20	633334	3500.01	DFT-s-OFDM PI/2 BPSK	1@1	25.15	24.89	0.3083
77	30	20	633334	3500.01	DFT-s-OFDM QPSK	1@1	25.21	24.95	0.3126
77	30	20	633334	3500.01	DFT-s-OFDM 16 QAM	1@1	24.15	23.89	0.2449
77	30	20	636000	3540	DFT-s-OFDM PI/2 BPSK	1@1	25.17	24.91	0.3097
77	30	20	636000	3540	DFT-s-OFDM QPSK	1@1	25.22	24.96	0.3133
77	30	20	636000	3540	DFT-s-OFDM 16 QAM	1@1	24.17	23.91	0.2460
77	30	25	630834	3462.51	DFT-s-OFDM PI/2 BPSK	1@1	25.06	24.8	0.3020
77	30	25	630834	3462.51	DFT-s-OFDM QPSK	1@1	25.21	24.95	0.3126
77	30	25	630834	3462.51	DFT-s-OFDM 16 QAM	1@1	23.95	23.69	0.2339
77	30	25	633334	3500.01	DFT-s-OFDM PI/2 BPSK	1@1	25.11	24.85	0.3055
77	30	25	633334	3500.01	DFT-s-OFDM QPSK	1@1	25.15	24.89	0.3083
77	30	25	633334	3500.01	DFT-s-OFDM 16 QAM	1@1	23.97	23.71	0.2350
77	30	25	635832	3537.48	DFT-s-OFDM PI/2 BPSK	1@1	25.11	24.85	0.3055
77	30	25	635832	3537.48	DFT-s-OFDM QPSK	1@1	25.15	24.89	0.3083
77	30	25	635832	3537.48	DFT-s-OFDM 16 QAM	1@1	24.1	23.84	0.2421
77	30	30	631000	3465	DFT-s-OFDM PI/2 BPSK	1@1	25.02	24.76	0.2992
77	30	30	631000	3465	DFT-s-OFDM QPSK	1@1	25.06	24.8	0.3020

77	30	30	631000	3465	DFT-s-OFDM 16 QAM	1@1	24.05	23.79	0.2393
77	30	30	633334	3500.01	DFT-s-OFDM PI/2 BPSK	1@1	25.12	24.86	0.3062
77	30	30	633334	3500.01	DFT-s-OFDM QPSK	1@1	25.14	24.88	0.3076
77	30	30	633334	3500.01	DFT-s-OFDM 16 QAM	1@1	24.15	23.89	0.2449
77	30	30	635666	3534.99	DFT-s-OFDM PI/2 BPSK	1@1	25.08	24.82	0.3034
77	30	30	635666	3534.99	DFT-s-OFDM QPSK	1@1	25.15	24.89	0.3083
77	30	30	635666	3534.99	DFT-s-OFDM 16 QAM	1@1	24.07	23.81	0.2404
77	30	40	631334	3470.01	DFT-s-OFDM PI/2 BPSK	1@1	25.04	24.78	0.3006
77	30	40	631334	3470.01	DFT-s-OFDM QPSK	1@1	25	24.74	0.2979
77	30	40	631334	3470.01	DFT-s-OFDM 16 QAM	1@1	24.07	23.81	0.2404
77	30	40	633334	3500.01	DFT-s-OFDM PI/2 BPSK	1@1	25.13	24.87	0.3069
77	30	40	633334	3500.01	DFT-s-OFDM QPSK	1@1	25.16	24.9	0.3090
77	30	40	633334	3500.01	DFT-s-OFDM 16 QAM	1@1	24.08	23.82	0.2410
77	30	40	635332	3529.98	DFT-s-OFDM PI/2 BPSK	1@1	25.1	24.84	0.3048
77	30	40	635332	3529.98	DFT-s-OFDM QPSK	1@1	25.23	24.97	0.3141
77	30	40	635332	3529.98	DFT-s-OFDM 16 QAM	1@1	24.12	23.86	0.2432
77	30	50	631668	3475.02	DFT-s-OFDM PI/2 BPSK	1@1	25.1	24.84	0.3048
77	30	50	631668	3475.02	DFT-s-OFDM QPSK	1@1	25.11	24.85	0.3055
77	30	50	631668	3475.02	DFT-s-OFDM 16 QAM	1@1	24.09	23.83	0.2415
77	30	50	633334	3500.01	DFT-s-OFDM PI/2 BPSK	1@1	25.06	24.8	0.3020
77	30	50	633334	3500.01	DFT-s-OFDM QPSK	1@1	25.12	24.86	0.3062
77	30	50	633334	3500.01	DFT-s-OFDM 16 QAM	1@1	24.1	23.84	0.2421
77	30	50	635000	3525	DFT-s-OFDM PI/2 BPSK	1@1	25.22	24.96	0.3133
77	30	50	635000	3525	DFT-s-OFDM QPSK	1@1	25.22	24.96	0.3133
77	30	50	635000	3525	DFT-s-OFDM 16 QAM	1@1	24.15	23.89	0.2449
77	30	60	632000	3480	DFT-s-OFDM PI/2 BPSK	1@1	25.1	24.84	0.3048
77	30	60	632000	3480	DFT-s-OFDM QPSK	1@1	25.22	24.96	0.3133
77	30	60	632000	3480	DFT-s-OFDM 16 QAM	1@1	24.1	23.84	0.2421
77	30	60	633334	3500.01	DFT-s-OFDM PI/2 BPSK	1@1	25.06	24.8	0.3020
77	30	60	633334	3500.01	DFT-s-OFDM QPSK	1@1	25.1	24.84	0.3048
77	30	60	633334	3500.01	DFT-s-OFDM 16 QAM	1@1	24.09	23.83	0.2415
77	30	60	634666	3519.99	DFT-s-OFDM PI/2 BPSK	1@1	25.15	24.89	0.3083
77	30	60	634666	3519.99	DFT-s-OFDM QPSK	1@1	25.25	24.99	0.3155
77	30	60	634666	3519.99	DFT-s-OFDM 16 QAM	1@1	24.16	23.9	0.2455
77	30	70	632334	3485.01	DFT-s-OFDM PI/2 BPSK	1@1	24.93	24.67	0.2931
77	30	70	632334	3485.01	DFT-s-OFDM QPSK	1@1	24.91	24.65	0.2917
77	30	70	632334	3485.01	DFT-s-OFDM 16 QAM	1@1	23.9	23.64	0.2312
77	30	70	633334	3500.01	DFT-s-OFDM PI/2 BPSK	1@1	24.93	24.67	0.2931
77	30	70	633334	3500.01	DFT-s-OFDM QPSK	1@1	24.94	24.68	0.2938
77	30	70	633334	3500.01	DFT-s-OFDM 16 QAM	1@1	23.89	23.63	0.2307
77	30	70	634332	3514.98	DFT-s-OFDM PI/2 BPSK	1@1	24.93	24.67	0.2931
77	30	70	634332	3514.98	DFT-s-OFDM QPSK	1@1	24.99	24.73	0.2972
77	30	70	634332	3514.98	DFT-s-OFDM 16 QAM	1@1	23.9	23.64	0.2312
77	30	80	632668	3490.02	DFT-s-OFDM PI/2 BPSK	1@1	24.97	24.71	0.2958

77	30	80	632668	3490.02	DFT-s-OFDM QPSK	1@1	24.96	24.7	0.2951
77	30	80	632668	3490.02	DFT-s-OFDM 16 QAM	1@1	23.94	23.68	0.2333
77	30	80	633334	3500.01	DFT-s-OFDM PI/2 BPSK	1@1	24.96	24.7	0.2951
77	30	80	633334	3500.01	DFT-s-OFDM QPSK	1@1	24.97	24.71	0.2958
77	30	80	633334	3500.01	DFT-s-OFDM 16 QAM	1@1	23.91	23.65	0.2317
77	30	80	634000	3510	DFT-s-OFDM PI/2 BPSK	1@1	24.96	24.7	0.2951
77	30	80	634000	3510	DFT-s-OFDM QPSK	1@1	24.99	24.73	0.2972
77	30	80	634000	3510	DFT-s-OFDM 16 QAM	1@1	23.98	23.72	0.2355
77	30	90	633000	3495	DFT-s-OFDM PI/2 BPSK	1@1	24.87	24.61	0.2891
77	30	90	633000	3495	DFT-s-OFDM QPSK	1@1	24.95	24.69	0.2944
77	30	90	633000	3495	DFT-s-OFDM 16 QAM	1@1	23.91	23.65	0.2317
77	30	90	633334	3500.01	DFT-s-OFDM PI/2 BPSK	1@1	24.95	24.69	0.2944
77	30	90	633334	3500.01	DFT-s-OFDM QPSK	1@1	24.96	24.7	0.2951
77	30	90	633334	3500.01	DFT-s-OFDM 16 QAM	1@1	23.92	23.66	0.2323
77	30	90	633666	3504.99	DFT-s-OFDM PI/2 BPSK	1@1	24.95	24.69	0.2944
77	30	90	633666	3504.99	DFT-s-OFDM QPSK	1@1	24.99	24.73	0.2972
77	30	90	633666	3504.99	DFT-s-OFDM 16 QAM	1@1	23.92	23.66	0.2323
77	30	100	633334	3500.01	DFT-s-OFDM PI/2 BPSK	135@67	25.18	24.92	0.3105
77	30	100	633334	3500.01	DFT-s-OFDM PI/2 BPSK	1@1	25.16	24.9	0.3090
77	30	100	633334	3500.01	DFT-s-OFDM PI/2 BPSK	1@271	24.85	24.59	0.2877
77	30	100	633334	3500.01	DFT-s-OFDM QPSK	135@67	25.17	24.91	0.3097
77	30	100	633334	3500.01	DFT-s-OFDM QPSK	1@1	25.31	25.05	0.3199
77	30	100	633334	3500.01	DFT-s-OFDM QPSK	1@271	24.9	24.64	0.2911
77	30	100	633334	3500.01	DFT-s-OFDM 16 QAM	135@67	24.18	23.92	0.2466
77	30	100	633334	3500.01	DFT-s-OFDM 16 QAM	1@1	24.21	23.95	0.2483
77	30	100	633334	3500.01	DFT-s-OFDM 16 QAM	1@271	23.79	23.53	0.2254
77	30	100	633334	3500.01	DFT-s-OFDM 64 QAM	135@67	22.65	22.39	0.1734
77	30	100	633334	3500.01	DFT-s-OFDM 64 QAM	1@1	22.66	22.4	0.1738
77	30	100	633334	3500.01	DFT-s-OFDM 64 QAM	1@271	22.35	22.09	0.1618
77	30	100	633334	3500.01	DFT-s-OFDM 256 QAM	135@67	20.69	20.43	0.1104
77	30	100	633334	3500.01	DFT-s-OFDM 256 QAM	1@1	20.24	19.98	0.0995
77	30	100	633334	3500.01	DFT-s-OFDM 256 QAM	1@271	19.97	19.71	0.0935
77	30	100	633334	3500.01	CP-OFDM QPSK	137@68	23.64	23.38	0.2178
77	30	100	633334	3500.01	CP-OFDM QPSK	1@1	23.72	23.46	0.2218
77	30	100	633334	3500.01	CP-OFDM QPSK	1@271	23.27	23.01	0.2000

# FR1 N78-Ant 5

## Transmitter Conducted Output Power And EIRP, (G<sub>T</sub> - L<sub>C</sub>)=-0.67dBi

NR Band	SCS	BandWidth	Arfcn	Freq(MHz)	Modulation	RB	Conducted Power(dBm)	EIRP(dBm)	EIRP(W)
78	30	10	630334	3455.01	DFT-s-OFDM PI/2 BPSK	1@1	26.1	25.43	0.3491
78	30	10	630334	3455.01	DFT-s-OFDM QPSK	1@1	26.14	25.47	0.3524
78	30	10	630334	3455.01	DFT-s-OFDM 16 QAM	1@1	25.17	24.5	0.2818
78	30	10	633334	3500.01	DFT-s-OFDM PI/2 BPSK	1@1	26.08	25.41	0.3475
78	30	10	633334	3500.01	DFT-s-OFDM QPSK	1@1	26.03	25.36	0.3436
78	30	10	633334	3500.01	DFT-s-OFDM 16 QAM	1@1	25.16	24.49	0.2812
78	30	10	636332	3544.98	DFT-s-OFDM PI/2 BPSK	1@1	26.12	25.45	0.3508
78	30	10	636332	3544.98	DFT-s-OFDM QPSK	1@1	26.23	25.56	0.3597
78	30	10	636332	3544.98	DFT-s-OFDM 16 QAM	1@1	25.25	24.58	0.2871
78	30	15	630500	3457.5	DFT-s-OFDM PI/2 BPSK	1@1	26.14	25.47	0.3524
78	30	15	630500	3457.5	DFT-s-OFDM QPSK	1@1	26.12	25.45	0.3508
78	30	15	630500	3457.5	DFT-s-OFDM 16 QAM	1@1	25.16	24.49	0.2812
78	30	15	633334	3500.01	DFT-s-OFDM PI/2 BPSK	1@1	26.08	25.41	0.3475
78	30	15	633334	3500.01	DFT-s-OFDM QPSK	1@1	26.06	25.39	0.3459
78	30	15	633334	3500.01	DFT-s-OFDM 16 QAM	1@1	25.14	24.47	0.2799
78	30	15	636166	3542.49	DFT-s-OFDM PI/2 BPSK	1@1	26.16	25.49	0.3540
78	30	15	636166	3542.49	DFT-s-OFDM QPSK	1@1	26.18	25.51	0.3556
78	30	15	636166	3542.49	DFT-s-OFDM 16 QAM	1@1	25.17	24.5	0.2818
78	30	20	630668	3460.02	DFT-s-OFDM PI/2 BPSK	1@1	26.16	25.49	0.3540
78	30	20	630668	3460.02	DFT-s-OFDM QPSK	1@1	26.14	25.47	0.3524
78	30	20	630668	3460.02	DFT-s-OFDM 16 QAM	1@1	25.21	24.54	0.2844
78	30	20	633334	3500.01	DFT-s-OFDM PI/2 BPSK	1@1	26.15	25.48	0.3532
78	30	20	633334	3500.01	DFT-s-OFDM QPSK	1@1	26.16	25.49	0.3540
78	30	20	633334	3500.01	DFT-s-OFDM 16 QAM	1@1	25.15	24.48	0.2805
78	30	20	636000	3540	DFT-s-OFDM PI/2 BPSK	1@1	26.13	25.46	0.3516
78	30	20	636000	3540	DFT-s-OFDM QPSK	1@1	26.25	25.58	0.3614
78	30	20	636000	3540	DFT-s-OFDM 16 QAM	1@1	25.27	24.6	0.2884
78	30	25	630834	3462.51	DFT-s-OFDM PI/2 BPSK	1@1	26.12	25.45	0.3508
78	30	25	630834	3462.51	DFT-s-OFDM QPSK	1@1	26.14	25.47	0.3524
78	30	25	630834	3462.51	DFT-s-OFDM 16 QAM	1@1	25.27	24.6	0.2884
78	30	25	633334	3500.01	DFT-s-OFDM PI/2 BPSK	1@1	26.07	25.4	0.3467
78	30	25	633334	3500.01	DFT-s-OFDM QPSK	1@1	26.11	25.44	0.3499
78	30	25	633334	3500.01	DFT-s-OFDM 16 QAM	1@1	25.29	24.62	0.2897
78	30	25	635832	3537.48	DFT-s-OFDM PI/2 BPSK	1@1	26.11	25.44	0.3499
78	30	25	635832	3537.48	DFT-s-OFDM QPSK	1@1	26.21	25.54	0.3581
78	30	25	635832	3537.48	DFT-s-OFDM 16 QAM	1@1	25.24	24.57	0.2864

78	30	30	631000	3465	DFT-s-OFDM PI/2 BPSK	1@1	26.18	25.51	0.3556
78	30	30	631000	3465	DFT-s-OFDM QPSK	1@1	26.24	25.57	0.3606
78	30	30	631000	3465	DFT-s-OFDM 16 QAM	1@1	25.47	24.8	0.3020
78	30	30	633334	3500.01	DFT-s-OFDM PI/2 BPSK	1@1	26.12	25.45	0.3508
78	30	30	633334	3500.01	DFT-s-OFDM QPSK	1@1	26.13	25.46	0.3516
78	30	30	633334	3500.01	DFT-s-OFDM 16 QAM	1@1	25.34	24.67	0.2931
78	30	30	635666	3534.99	DFT-s-OFDM PI/2 BPSK	1@1	26.15	25.48	0.3532
78	30	30	635666	3534.99	DFT-s-OFDM QPSK	1@1	26.25	25.58	0.3614
78	30	30	635666	3534.99	DFT-s-OFDM 16 QAM	1@1	25.4	24.73	0.2972
78	30	40	631334	3470.01	DFT-s-OFDM PI/2 BPSK	1@1	26.21	25.54	0.3581
78	30	40	631334	3470.01	DFT-s-OFDM QPSK	1@1	26.23	25.56	0.3597
78	30	40	631334	3470.01	DFT-s-OFDM 16 QAM	1@1	25.54	24.87	0.3069
78	30	40	633334	3500.01	DFT-s-OFDM PI/2 BPSK	1@1	26.12	25.45	0.3508
78	30	40	633334	3500.01	DFT-s-OFDM QPSK	1@1	26.24	25.57	0.3606
78	30	40	633334	3500.01	DFT-s-OFDM 16 QAM	1@1	25.48	24.81	0.3027
78	30	40	635332	3529.98	DFT-s-OFDM PI/2 BPSK	1@1	26.2	25.53	0.3573
78	30	40	635332	3529.98	DFT-s-OFDM QPSK	1@1	26.19	25.52	0.3565
78	30	40	635332	3529.98	DFT-s-OFDM 16 QAM	1@1	25.29	24.62	0.2897
78	30	50	631668	3475.02	DFT-s-OFDM PI/2 BPSK	1@1	26.24	25.57	0.3606
78	30	50	631668	3475.02	DFT-s-OFDM QPSK	1@1	26.25	25.58	0.3614
78	30	50	631668	3475.02	DFT-s-OFDM 16 QAM	1@1	25.35	24.68	0.2938
78	30	50	633334	3500.01	DFT-s-OFDM PI/2 BPSK	1@1	26.16	25.49	0.3540
78	30	50	633334	3500.01	DFT-s-OFDM QPSK	1@1	26.16	25.49	0.3540
78	30	50	633334	3500.01	DFT-s-OFDM 16 QAM	1@1	25.32	24.65	0.2917
78	30	50	635000	3525	DFT-s-OFDM PI/2 BPSK	1@1	26.24	25.57	0.3606
78	30	50	635000	3525	DFT-s-OFDM QPSK	1@1	26.26	25.59	0.3622
78	30	50	635000	3525	DFT-s-OFDM 16 QAM	1@1	25.35	24.68	0.2938
78	30	60	632000	3480	DFT-s-OFDM PI/2 BPSK	1@1	26.19	25.52	0.3565
78	30	60	632000	3480	DFT-s-OFDM QPSK	1@1	26.19	25.52	0.3565
78	30	60	632000	3480	DFT-s-OFDM 16 QAM	1@1	25.33	24.66	0.2924
78	30	60	633334	3500.01	DFT-s-OFDM PI/2 BPSK	1@1	26.16	25.49	0.3540
78	30	60	633334	3500.01	DFT-s-OFDM QPSK	1@1	26.15	25.48	0.3532
78	30	60	633334	3500.01	DFT-s-OFDM 16 QAM	1@1	25.32	24.65	0.2917
78	30	60	634666	3519.99	DFT-s-OFDM PI/2 BPSK	1@1	26.18	25.51	0.3556
78	30	60	634666	3519.99	DFT-s-OFDM QPSK	1@1	26.24	25.57	0.3606
78	30	60	634666	3519.99	DFT-s-OFDM 16 QAM	1@1	25.35	24.68	0.2938
78	30	70	632334	3485.01	DFT-s-OFDM PI/2 BPSK	1@1	26.13	25.46	0.3516
78	30	70	632334	3485.01	DFT-s-OFDM QPSK	1@1	26.2	25.53	0.3573
78	30	70	632334	3485.01	DFT-s-OFDM 16 QAM	1@1	25.13	24.46	0.2793
78	30	70	633334	3500.01	DFT-s-OFDM PI/2 BPSK	1@1	26.14	25.47	0.3524
78	30	70	633334	3500.01	DFT-s-OFDM QPSK	1@1	26.17	25.5	0.3548
78	30	70	633334	3500.01	DFT-s-OFDM 16 QAM	1@1	25.1	24.43	0.2773
78	30	70	634332	3514.98	DFT-s-OFDM PI/2 BPSK	1@1	26.13	25.46	0.3516
78	30	70	634332	3514.98	DFT-s-OFDM QPSK	1@1	26.19	25.52	0.3565

78	30	70	634332	3514.98	DFT-s-OFDM 16 QAM	1@1	25.11	24.44	0.2780
78	30	80	632668	3490.02	DFT-s-OFDM PI/2 BPSK	1@1	26.2	25.53	0.3573
78	30	80	632668	3490.02	DFT-s-OFDM QPSK	1@1	26.24	25.57	0.3606
78	30	80	632668	3490.02	DFT-s-OFDM 16 QAM	1@1	25.17	24.5	0.2818
78	30	80	633334	3500.01	DFT-s-OFDM PI/2 BPSK	1@1	26.19	25.52	0.3565
78	30	80	633334	3500.01	DFT-s-OFDM QPSK	1@1	26.24	25.57	0.3606
78	30	80	633334	3500.01	DFT-s-OFDM 16 QAM	1@1	25.13	24.46	0.2793
78	30	80	634000	3510	DFT-s-OFDM PI/2 BPSK	1@1	26.28	25.61	0.3639
78	30	80	634000	3510	DFT-s-OFDM QPSK	1@1	26.12	25.45	0.3508
78	30	80	634000	3510	DFT-s-OFDM 16 QAM	1@1	25.15	24.48	0.2805
78	30	90	633000	3495	DFT-s-OFDM PI/2 BPSK	1@1	26.15	25.48	0.3532
78	30	90	633000	3495	DFT-s-OFDM QPSK	1@1	26.21	25.54	0.3581
78	30	90	633000	3495	DFT-s-OFDM 16 QAM	1@1	25.17	24.5	0.2818
78	30	90	633334	3500.01	DFT-s-OFDM PI/2 BPSK	1@1	26.12	25.45	0.3508
78	30	90	633334	3500.01	DFT-s-OFDM QPSK	1@1	26.21	25.54	0.3581
78	30	90	633334	3500.01	DFT-s-OFDM 16 QAM	1@1	25.12	24.45	0.2786
78	30	90	633666	3504.99	DFT-s-OFDM PI/2 BPSK	1@1	26.29	25.62	0.3648
78	30	90	633666	3504.99	DFT-s-OFDM QPSK	1@1	26.14	25.47	0.3524
78	30	90	633666	3504.99	DFT-s-OFDM 16 QAM	1@1	25.15	24.48	0.2805
78	30	100	633334	3500.01	DFT-s-OFDM PI/2 BPSK	135@67	26.15	25.48	0.3532
78	30	100	633334	3500.01	DFT-s-OFDM PI/2 BPSK	1@1	26.36	25.69	0.3707
78	30	100	633334	3500.01	DFT-s-OFDM PI/2 BPSK	1@271	26.04	25.37	0.3443
78	30	100	633334	3500.01	DFT-s-OFDM QPSK	135@67	26.07	25.4	0.3467
78	30	100	633334	3500.01	DFT-s-OFDM QPSK	1@1	26.11	25.44	0.3499
78	30	100	633334	3500.01	DFT-s-OFDM QPSK	1@271	26.13	25.46	0.3516
78	30	100	633334	3500.01	DFT-s-OFDM 16 QAM	135@67	25.12	24.45	0.2786
78	30	100	633334	3500.01	DFT-s-OFDM 16 QAM	1@1	25.17	24.5	0.2818
78	30	100	633334	3500.01	DFT-s-OFDM 16 QAM	1@271	24.99	24.32	0.2704
78	30	100	633334	3500.01	DFT-s-OFDM 64 QAM	135@67	23.89	23.22	0.2099
78	30	100	633334	3500.01	DFT-s-OFDM 64 QAM	1@1	23.93	23.26	0.2118
78	30	100	633334	3500.01	DFT-s-OFDM 64 QAM	1@271	23.68	23.01	0.2000
78	30	100	633334	3500.01	DFT-s-OFDM 256 QAM	135@67	21.85	21.18	0.1312
78	30	100	633334	3500.01	DFT-s-OFDM 256 QAM	1@1	21.75	21.08	0.1282
78	30	100	633334	3500.01	DFT-s-OFDM 256 QAM	1@271	21.49	20.82	0.1208
78	30	100	633334	3500.01	CP-OFDM QPSK	137@68	24.88	24.21	0.2636
78	30	100	633334	3500.01	CP-OFDM QPSK	1@1	24.92	24.25	0.2661
78	30	100	633334	3500.01	CP-OFDM QPSK	1@271	24.55	23.88	0.2443

## Frequency Stability

NR Band	SCS (kHz)	Bandwidth (MHz)	Arfcn	Freq (MHz)	Modulation	RB	Deviation (ppm)	Verdict	Environment
78	30	10	633334	3500.01	DFT-s-OFDM QPSK	24@0	0.0021	PASS	NV
78	30	10	633334	3500.01	DFT-s-OFDM QPSK	24@0	-0.0009	PASS	LV
78	30	10	633334	3500.01	DFT-s-OFDM QPSK	24@0	0.0014	PASS	HV
78	30	10	633334	3500.01	DFT-s-OFDM QPSK	24@0	-0.0021	PASS	-30°C
78	30	10	633334	3500.01	DFT-s-OFDM QPSK	24@0	0.0025	PASS	-20°C
78	30	10	633334	3500.01	DFT-s-OFDM QPSK	24@0	0.0026	PASS	-10°C
78	30	10	633334	3500.01	DFT-s-OFDM QPSK	24@0	-0.0013	PASS	0°C
78	30	10	633334	3500.01	DFT-s-OFDM QPSK	24@0	0.0016	PASS	10°C
78	30	10	633334	3500.01	DFT-s-OFDM QPSK	24@0	-0.0017	PASS	20°C
78	30	10	633334	3500.01	DFT-s-OFDM QPSK	24@0	0.0029	PASS	30°C
78	30	10	633334	3500.01	DFT-s-OFDM QPSK	24@0	0.0011	PASS	40°C
78	30	10	633334	3500.01	DFT-s-OFDM QPSK	24@0	0.0015	PASS	50°C



## Peak to Average Ratio

NR Band	SCS (kHz)	Bandwidth (MHz)	Arfcn	Freq (MHz)	Modulation	RB	Result (dB)	Limit (dB)	Verdict
78	30	100	633334	3500.01	DFT-s-OFDM PI/2 BPSK	270@0	10.06	13	PASS
78	30	100	633334	3500.01	DFT-s-OFDM PI/2 BPSK	1@0	7.51	13	PASS
78	30	100	633334	3500.01	DFT-s-OFDM QPSK	270@0	8.49	13	PASS
78	30	100	633334	3500.01	DFT-s-OFDM QPSK	1@0	8.95	13	PASS

N78(100M)\_DFT-s-OFDM\_PI\_2-BPSK\_Outer\_Full\_Mid\_CH



N78(100M)\_DFT-s-OFDM\_PI\_2-BPSK\_Edge\_1RB\_Left\_Mid\_CH

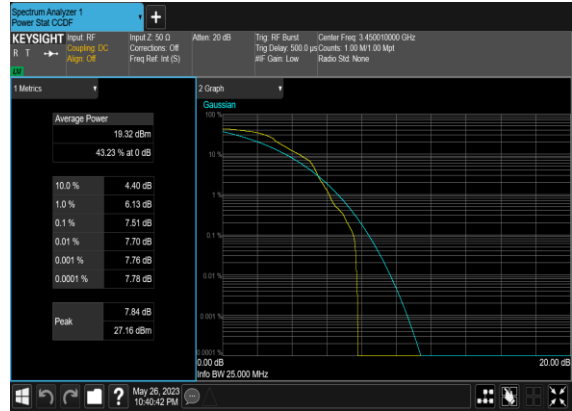

N78(100M)\_DFT-s-OFDM\_QPSK\_Outer\_Full\_Mid\_CH



N78(100M)\_DFT-s-OFDM\_QPSK\_Edge\_1RB\_Left\_Mid\_CH

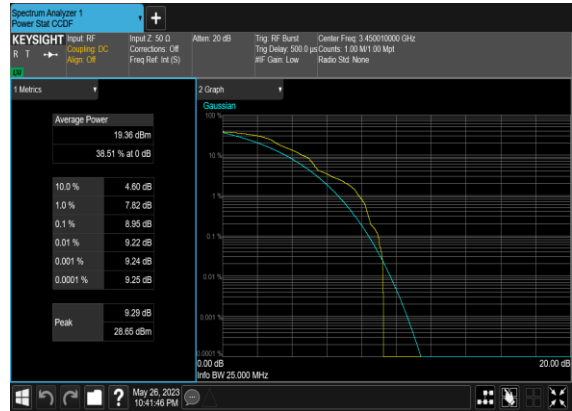

## Occupied Bandwidth

NR Band	SCS (kHz)	Bandwidth (MHz)	Arfcn	Freq (MHz)	Modulation	RB	OBW (MHz)	26dB BW (MHz)
78	30	10	633334	3500.01	CP-OFDM QPSK	24@0	8.5628	9.23
78	30	10	633334	3500.01	CP-OFDM 16 QAM	24@0	8.5691	9.157
78	30	10	633334	3500.01	CP-OFDM 64 QAM	24@0	8.5789	9.184
78	30	10	633334	3500.01	CP-OFDM 256 QAM	24@0	8.5653	9.188
78	30	15	633334	3500.01	CP-OFDM QPSK	38@0	13.566	14.1
78	30	15	633334	3500.01	CP-OFDM 16 QAM	38@0	13.578	14.23
78	30	15	633334	3500.01	CP-OFDM 64 QAM	38@0	13.542	14.21
78	30	15	633334	3500.01	CP-OFDM 256 QAM	38@0	13.538	14.26
78	30	20	633334	3500.01	CP-OFDM QPSK	51@0	18.218	18.99
78	30	20	633334	3500.01	CP-OFDM 16 QAM	51@0	18.227	18.86
78	30	20	633334	3500.01	CP-OFDM 64 QAM	51@0	18.228	18.9
78	30	20	633334	3500.01	CP-OFDM 256 QAM	51@0	18.129	18.88
78	30	25	633334	3500.01	CP-OFDM QPSK	65@0	23.189	24.07
78	30	25	633334	3500.01	CP-OFDM 16 QAM	65@0	23.111	24.09
78	30	25	633334	3500.01	CP-OFDM 64 QAM	65@0	23.157	23.93
78	30	25	633334	3500.01	CP-OFDM 256 QAM	65@0	23.208	23.96
78	30	30	633334	3500.01	CP-OFDM QPSK	78@0	27.799	29.06
78	30	30	633334	3500.01	CP-OFDM 16 QAM	78@0	27.851	28.89
78	30	30	633334	3500.01	CP-OFDM 64 QAM	78@0	27.891	28.93
78	30	30	633334	3500.01	CP-OFDM 256 QAM	78@0	27.789	28.85
78	30	40	633334	3500.01	CP-OFDM QPSK	106@0	37.733	39.12
78	30	40	633334	3500.01	CP-OFDM 16 QAM	106@0	37.804	39.62
78	30	40	633334	3500.01	CP-OFDM 64 QAM	106@0	37.788	39.14
78	30	40	633334	3500.01	CP-OFDM 256 QAM	106@0	37.791	39.12
78	30	50	633334	3500.01	CP-OFDM QPSK	133@0	47.295	49.02

78	30	50	633334	3500.01	CP-OFDM 16 QAM	133@0	47.374	49.04
78	30	50	633334	3500.01	CP-OFDM 64 QAM	133@0	47.424	49.08
78	30	50	633334	3500.01	CP-OFDM 256 QAM	133@0	47.337	49.01
78	30	60	633334	3500.01	CP-OFDM QPSK	162@0	57.615	59.62
78	30	60	633334	3500.01	CP-OFDM 16 QAM	162@0	57.89	59.63
78	30	60	633334	3500.01	CP-OFDM 64 QAM	162@0	57.725	59.73
78	30	60	633334	3500.01	CP-OFDM 256 QAM	162@0	57.592	59.71
78	30	70	633334	3500.01	CP-OFDM QPSK	189@0	67.408	69.45
78	30	70	633334	3500.01	CP-OFDM 16 QAM	189@0	67.606	69.6
78	30	70	633334	3500.01	CP-OFDM 64 QAM	189@0	67.429	69.57
78	30	70	633334	3500.01	CP-OFDM 256 QAM	189@0	67.322	69.62
78	30	80	633334	3500.01	CP-OFDM QPSK	217@0	77.326	80.0
78	30	80	633334	3500.01	CP-OFDM 16 QAM	217@0	77.284	79.91
78	30	80	633334	3500.01	CP-OFDM 64 QAM	217@0	77.371	79.89
78	30	80	633334	3500.01	CP-OFDM 256 QAM	217@0	77.33	79.89
78	30	90	633334	3500.01	CP-OFDM QPSK	245@0	87.415	90.2
78	30	90	633334	3500.01	CP-OFDM 16 QAM	245@0	87.4	90.16
78	30	90	633334	3500.01	CP-OFDM 64 QAM	245@0	87.531	90.12
78	30	90	633334	3500.01	CP-OFDM 256 QAM	245@0	87.21	90.22
78	30	100	633334	3500.01	CP-OFDM QPSK	273@0	97.432	100.4
78	30	100	633334	3500.01	CP-OFDM 16 QAM	273@0	97.484	100.5
78	30	100	633334	3500.01	CP-OFDM 64 QAM	273@0	97.404	100.5
78	30	100	633334	3500.01	CP-OFDM 256 QAM	273@0	97.261	100.5

### N78(10M)\_CP-OFDM\_QPSK\_Outer\_Full\_Mid\_CH

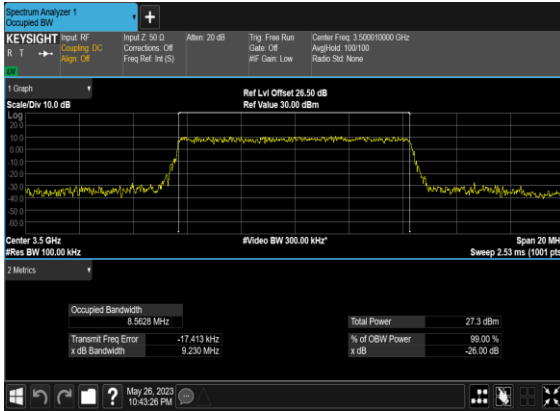

### N78(10M)\_CP-OFDM\_16QAM\_Outer\_Full\_Mid\_CH

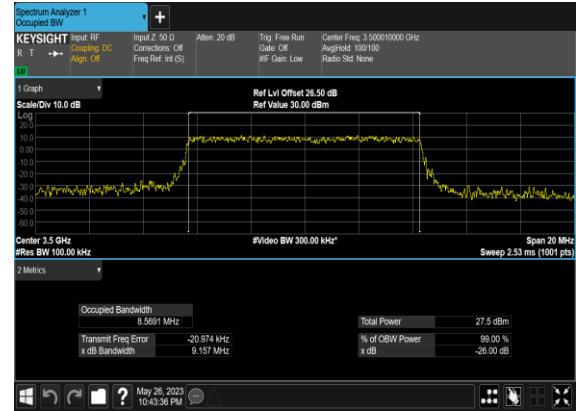

### N78(10M)\_CP-OFDM\_64QAM\_Outer\_Full\_Mid\_CH

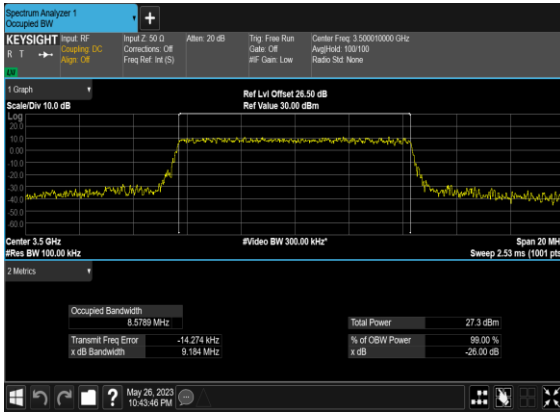

### N78(10M)\_CP-OFDM\_256QAM\_Outer\_Full\_Mid\_CH

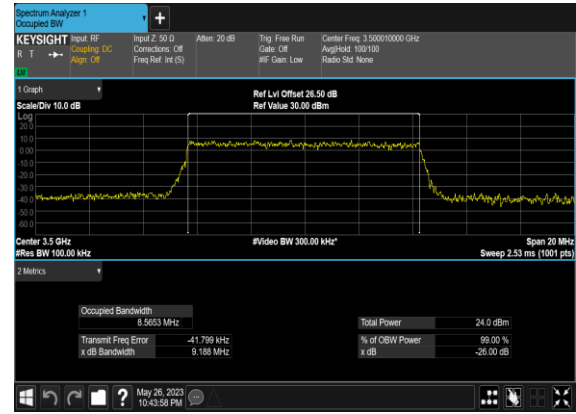

### N78(15M)\_CP-OFDM\_QPSK\_Outer\_Full\_Mid\_CH

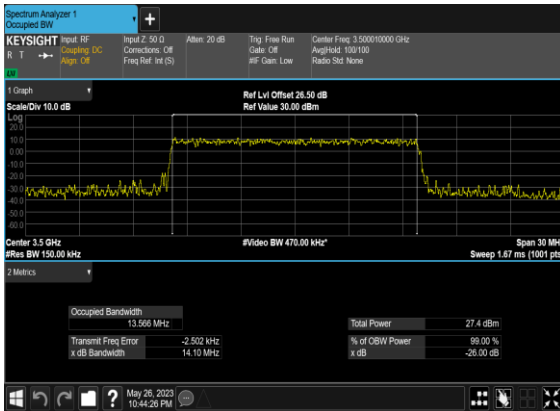

### N78(15M)\_CP-OFDM\_16QAM\_Outer\_Full\_Mid\_CH

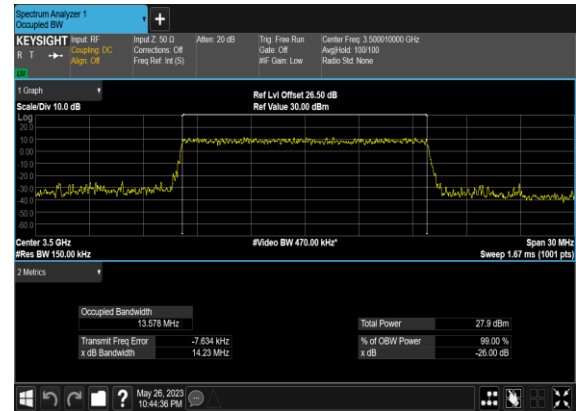

### N78(15M)\_CP-OFDM\_64 QAM\_Outer\_Full\_Mid\_CH

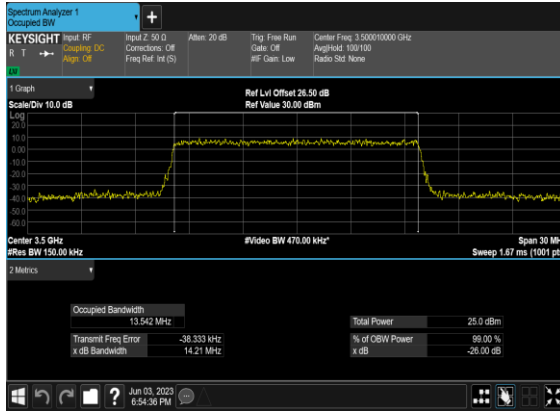

### N78(15M)\_CP-OFDM\_256 QAM\_Outer\_Full\_Mid\_CH

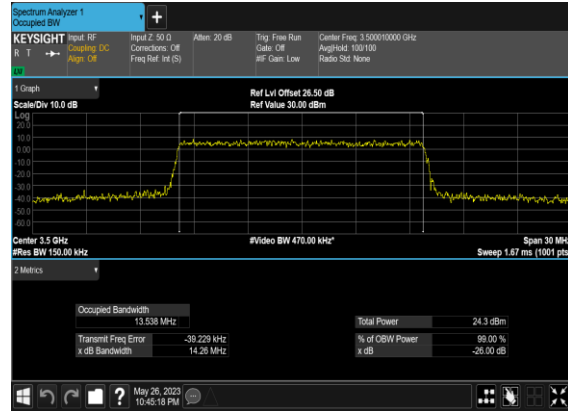

### N78(20M)\_CP- OFDM\_QPSK\_Outer\_Full\_Mid\_CH

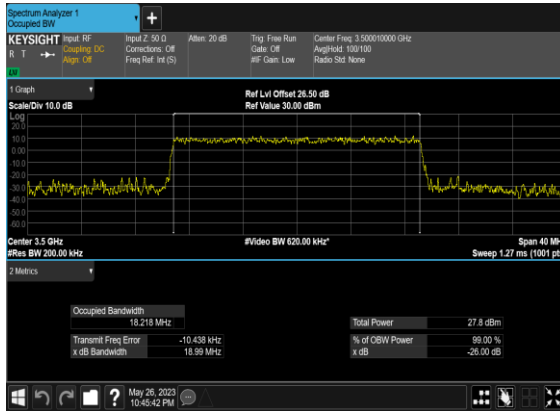

### N78(20M)\_CP-OFDM\_16 QAM\_Outer\_Full\_Mid\_CH

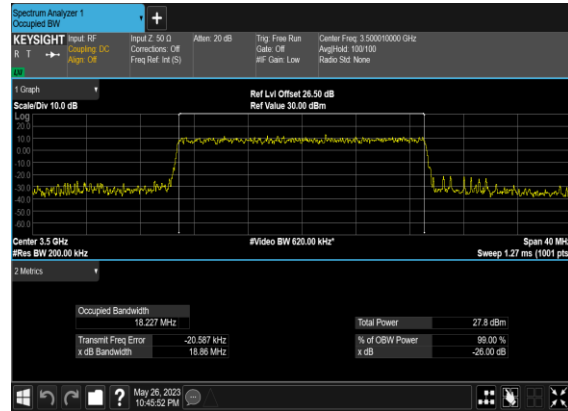

### N78(20M)\_CP-OFDM\_64 QAM\_Outer\_Full\_Mid\_CH

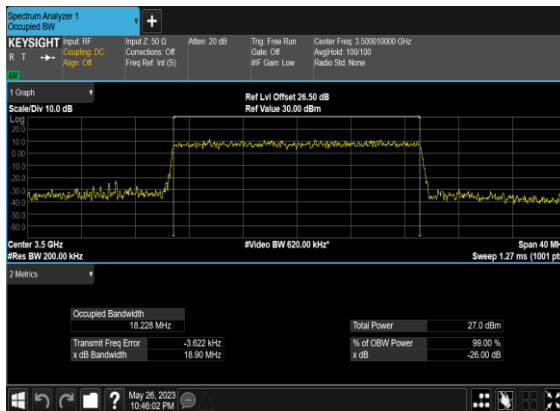

### N78(20M)\_CP-OFDM\_256 QAM\_Outer\_Full\_Mid\_CH

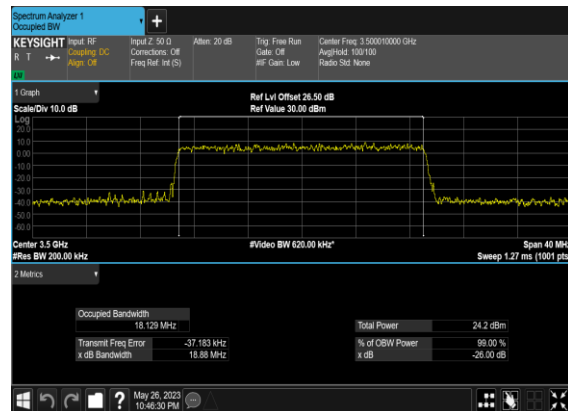

### N78(25M)\_CP-OFDM\_QPSK\_Outer\_Full\_Mid\_CH

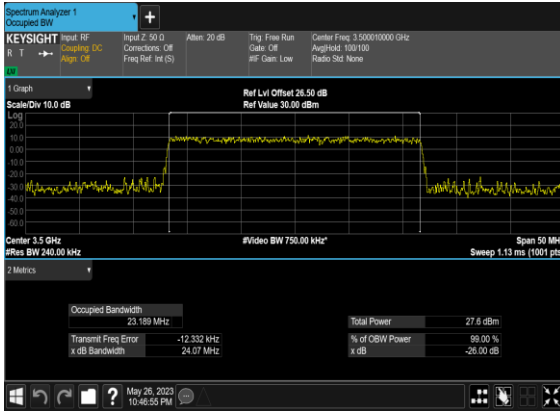

### N78(25M)\_CP-OFDM\_16 QAM\_Outer\_Full\_Mid\_CH

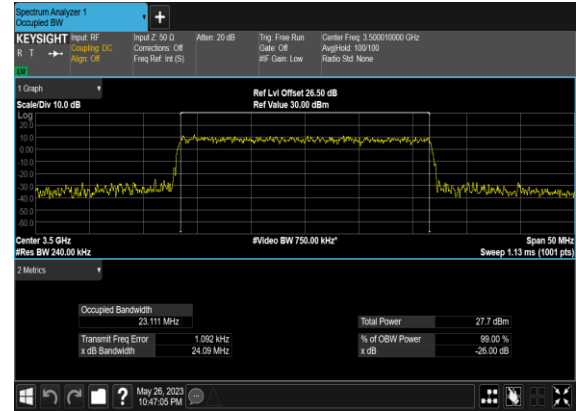

### N78(25M)\_CP-OFDM\_64 QAM\_Outer\_Full\_Mid\_CH

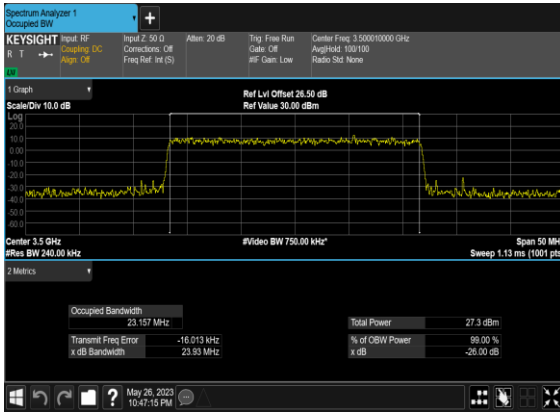

### N78(25M)\_CP-OFDM\_256 QAM\_Outer\_Full\_Mid\_CH

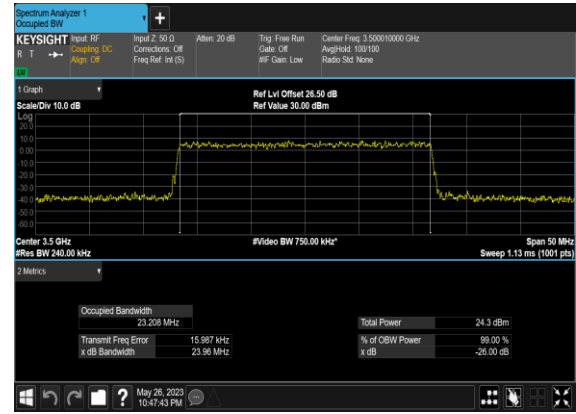

### N78(30M)\_CP-OFDM\_QPSK\_Outer\_Full\_Mid\_CH

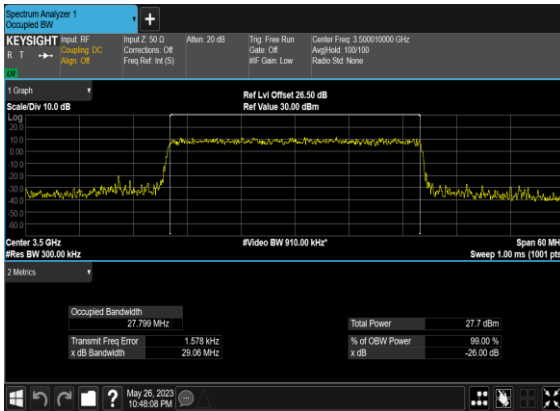

### N78(30M)\_CP-OFDM\_16 QAM\_Outer\_Full\_Mid\_CH

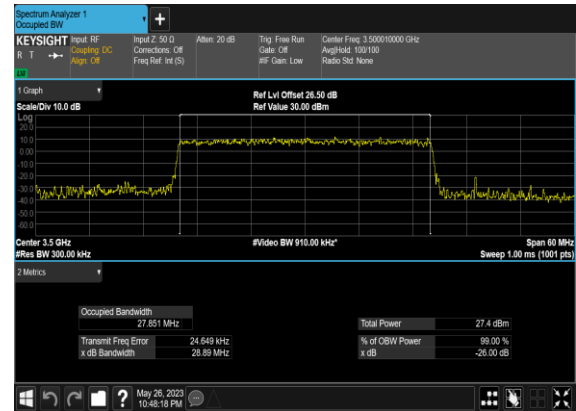

### N78(30M)\_CP-OFDM\_64 QAM\_Outer\_Full\_Mid\_CH

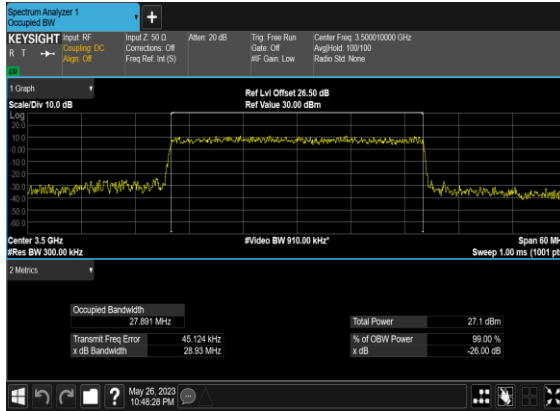

### N78(30M)\_CP-OFDM\_256 QAM\_Outer\_Full\_Mid\_CH

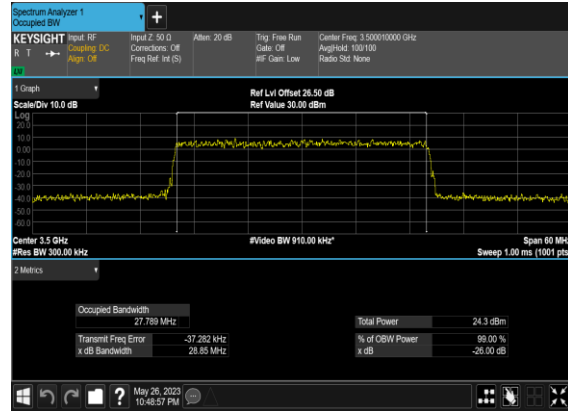

### N78(40M)\_CP- OFDM\_QPSK\_Outer\_Full\_Mid\_CH

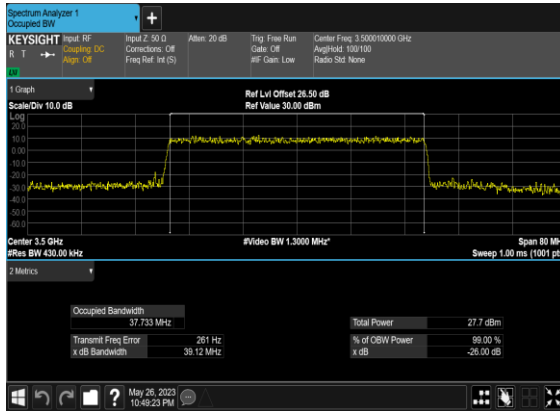

### N78(40M)\_CP-OFDM\_16 QAM\_Outer\_Full\_Mid\_CH

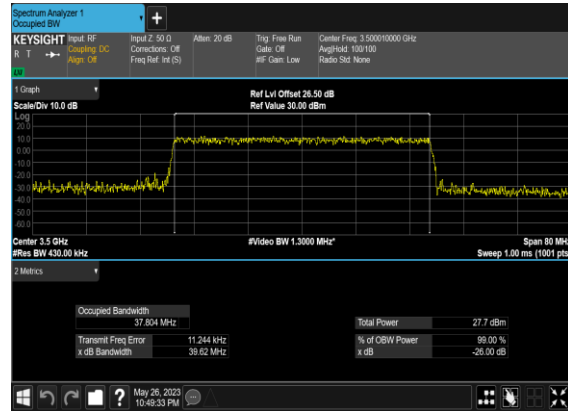

### N78(40M)\_CP-OFDM\_64 QAM\_Outer\_Full\_Mid\_CH

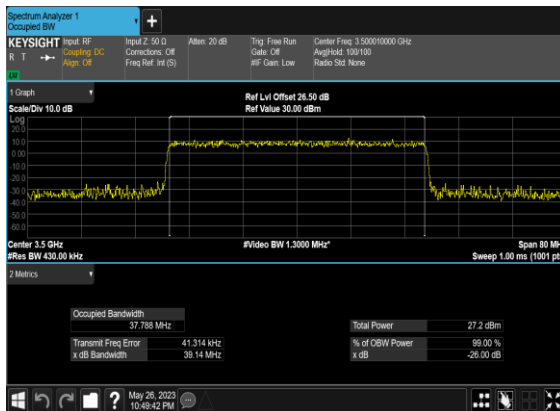

### N78(40M)\_CP-OFDM\_256 QAM\_Outer\_Full\_Mid\_CH

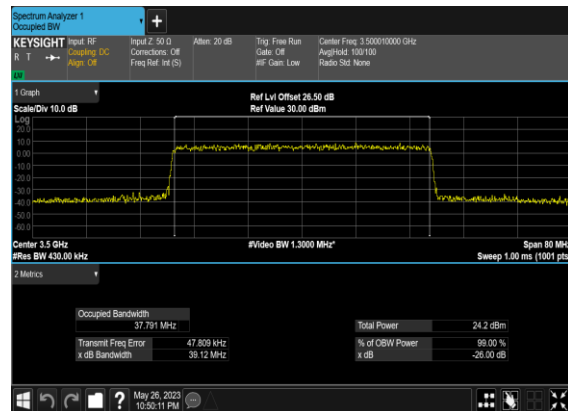



### N78(50M)\_CP- OFDM\_QPSK\_Outer\_Full\_Mid\_CH

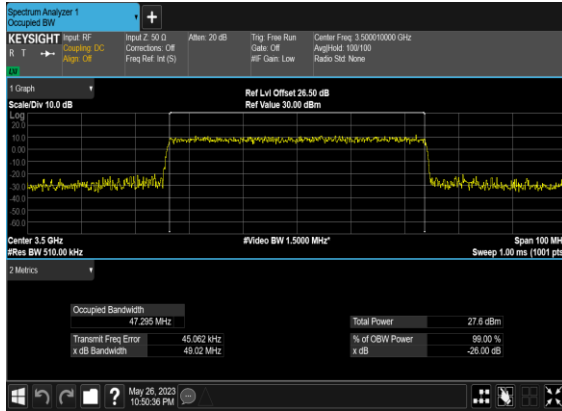

### N78(50M)\_CP-OFDM\_16 QAM\_Outer\_Full\_Mid\_CH

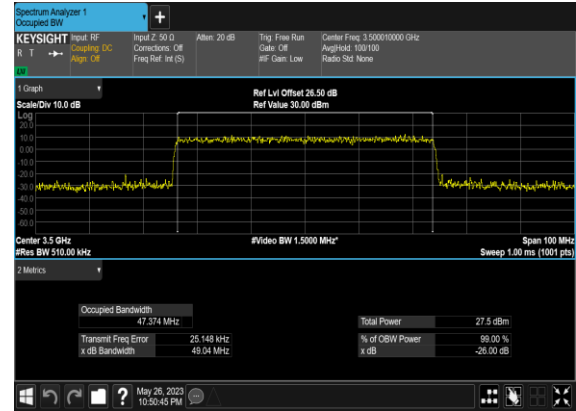

### N78(50M)\_CP-OFDM\_64 QAM\_Outer\_Full\_Mid\_CH

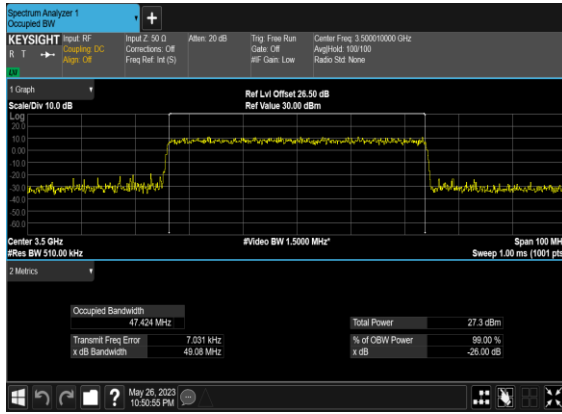

### N78(50M)\_CP-OFDM\_256 QAM\_Outer\_Full\_Mid\_CH

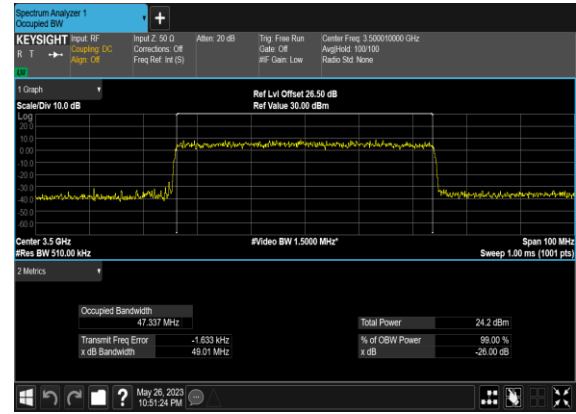

### N78(60M)\_CP- OFDM\_QPSK\_Outer\_Full\_Mid\_CH

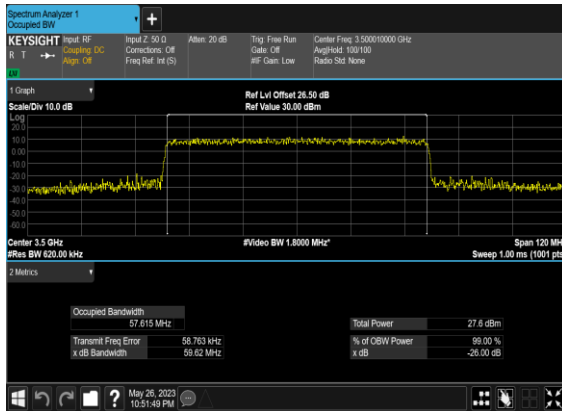

### N78(60M)\_CP-OFDM\_16 QAM\_Outer\_Full\_Mid\_CH

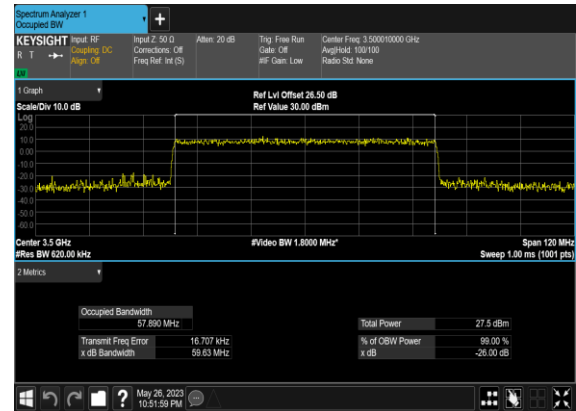

### N78(60M)\_CP-OFDM\_64 QAM\_Outer\_Full\_Mid\_CH

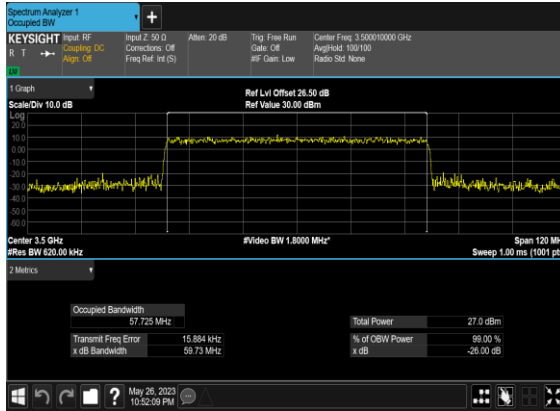

### N78(60M)\_CP-OFDM\_256 QAM\_Outer\_Full\_Mid\_CH

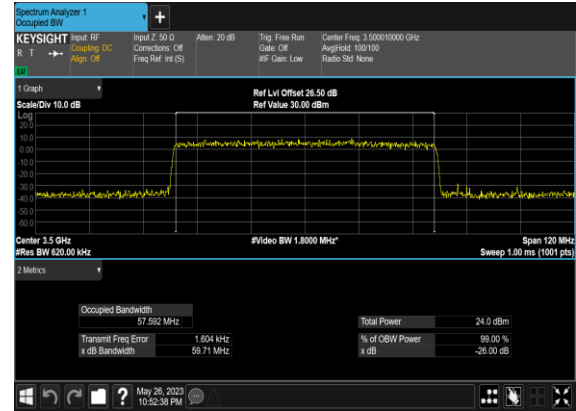

### N78(70M)\_CP- OFDM\_QPSK\_Outer\_Full\_Mid\_CH

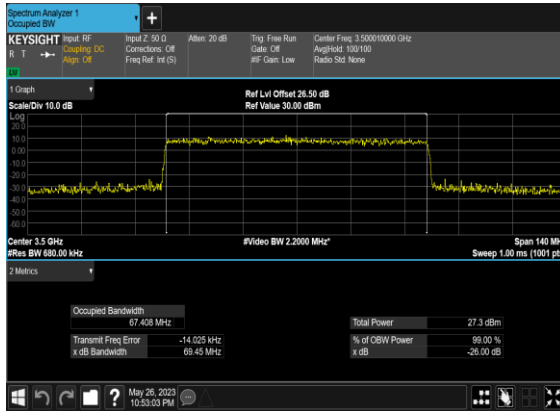

### N78(70M)\_CP-OFDM\_16 QAM\_Outer\_Full\_Mid\_CH

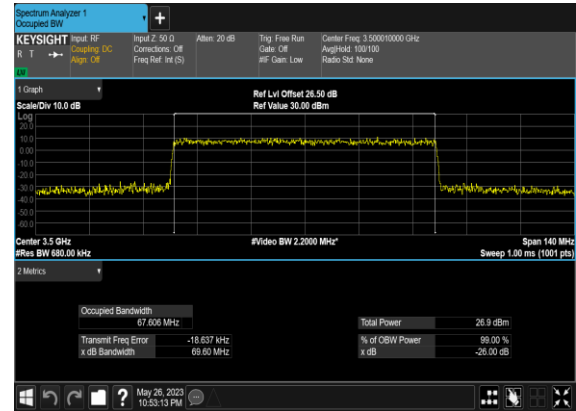

### N78(70M)\_CP-OFDM\_64 QAM\_Outer\_Full\_Mid\_CH

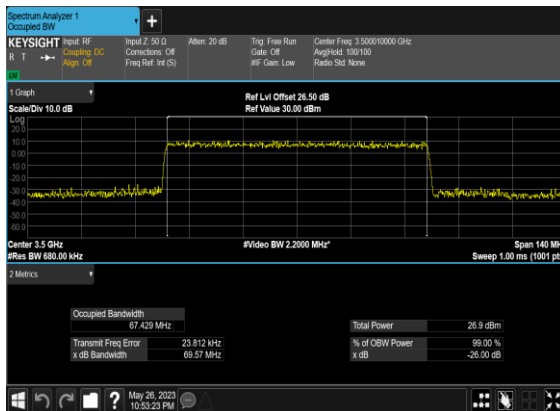

### N78(70M)\_CP-OFDM\_256 QAM\_Outer\_Full\_Mid\_CH

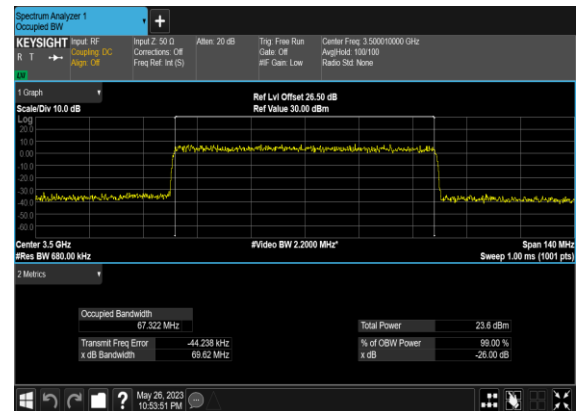

### N78(80M)\_CP-OFDM\_QPSK\_Outer\_Full\_Mid\_CH

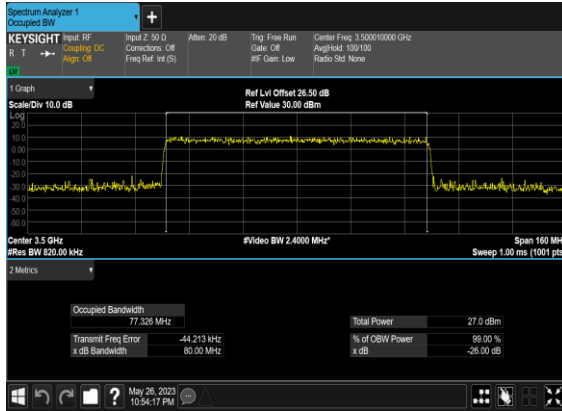

### N78(80M)\_CP-OFDM\_16QAM\_Outer\_Full\_Mid\_CH

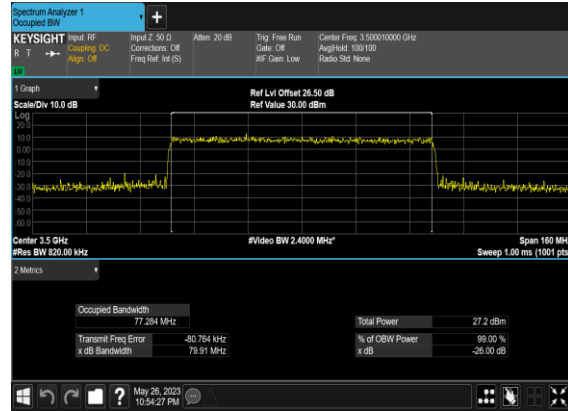

### N78(80M)\_CP-OFDM\_64QAM\_Outer\_Full\_Mid\_CH

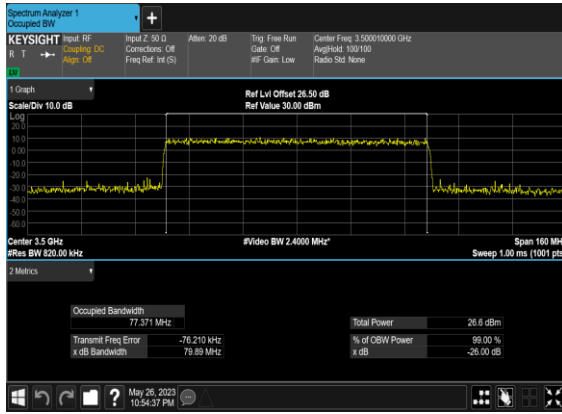

### N78(80M)\_CP-OFDM\_256QAM\_Outer\_Full\_Mid\_CH

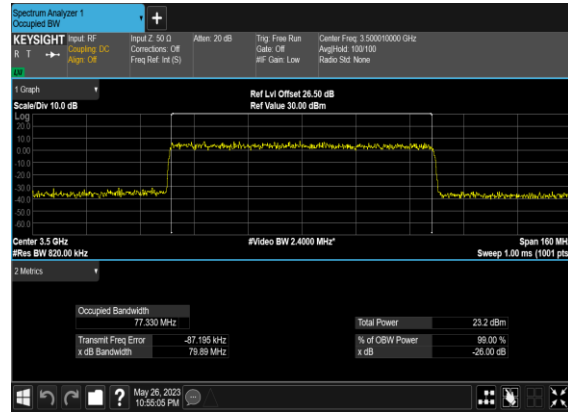

### N78(90M)\_CP-OFDM\_QPSK\_Outer\_Full\_Mid\_CH

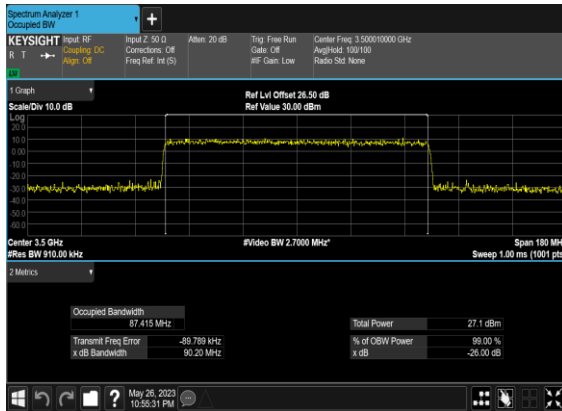

### N78(90M)\_CP-OFDM\_16QAM\_Outer\_Full\_Mid\_CH

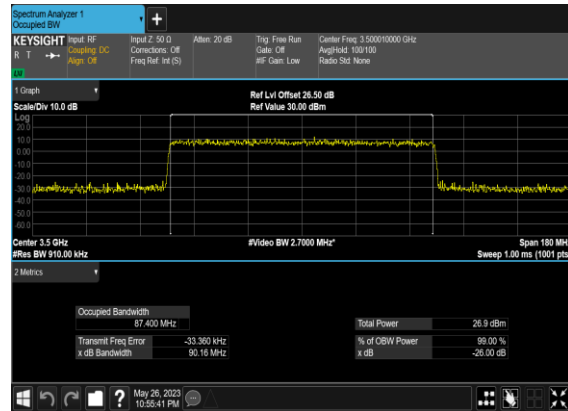

### N78(90M)\_CP-OFDM\_64 QAM\_Outer\_Full\_Mid\_CH

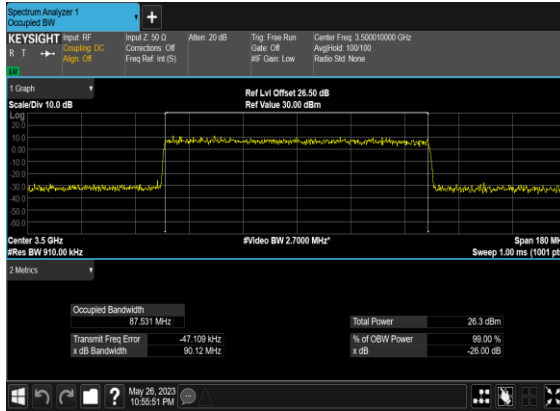

### N78(90M)\_CP-OFDM\_256 QAM\_Outer\_Full\_Mid\_CH

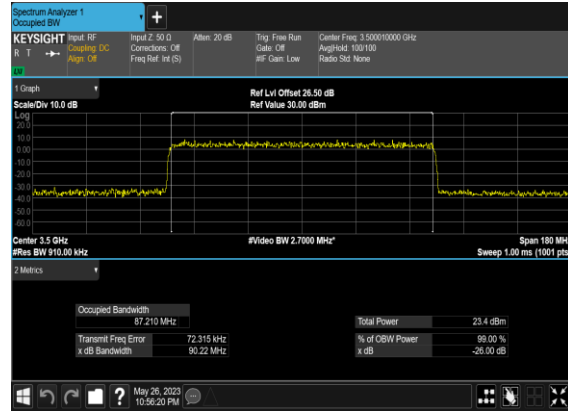

### N78(100M)\_CP- OFDM\_QPSK\_Outer\_Full\_Mid\_CH

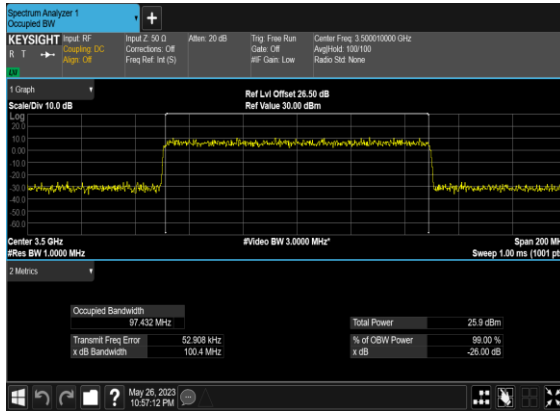

### N78(100M)\_CP-OFDM\_16 QAM\_Outer\_Full\_Mid\_CH

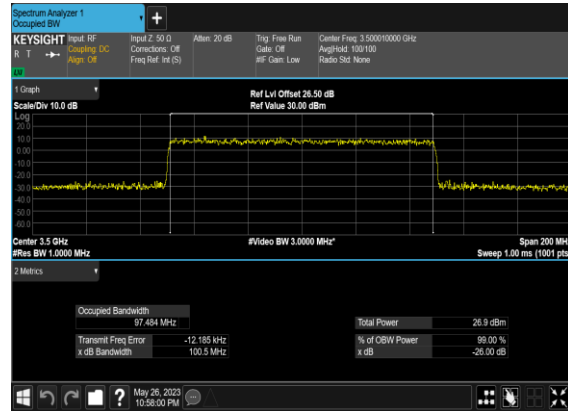

### N78(100M)\_CP-OFDM\_64 QAM\_Outer\_Full\_Mid\_CH

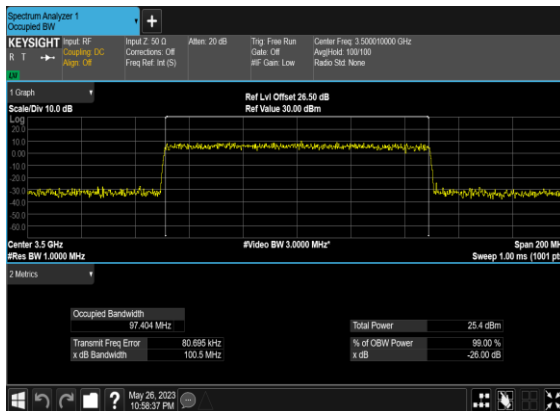

### N78(100M)\_CP-OFDM\_256 QAM\_Outer\_Full\_Mid\_CH

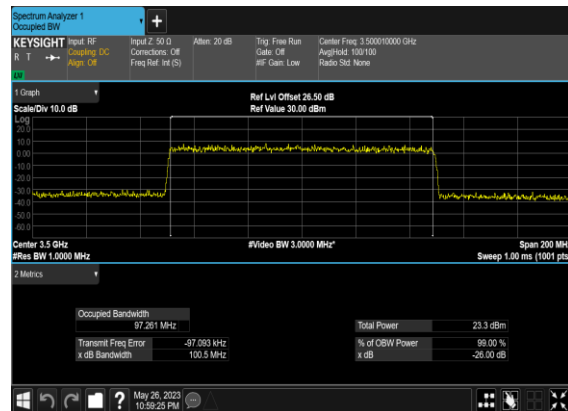

## Conducted Spurious Emissions

NR Band	SCS (kHz)	Bandwidth (MHz)	Arfcn	Freq (MHz)	Modulation	RB	Result	Verdict
78	30	10	630334	3455.01	DFT-s-OFDM BPSK	1@0	see graph	---
78	30	10	630334	3455.01	DFT-s-OFDM BPSK	1@0	see graph	PASS
78	30	10	630334	3455.01	DFT-s-OFDM BPSK	1@0	see graph	PASS
78	30	10	630334	3455.01	DFT-s-OFDM QPSK	1@0	see graph	---
78	30	10	630334	3455.01	DFT-s-OFDM QPSK	1@0	see graph	PASS
78	30	10	630334	3455.01	DFT-s-OFDM QPSK	1@0	see graph	PASS
78	30	10	633334	3500.01	DFT-s-OFDM BPSK	1@0	see graph	---
78	30	10	633334	3500.01	DFT-s-OFDM BPSK	1@0	see graph	PASS
78	30	10	633334	3500.01	DFT-s-OFDM BPSK	1@0	see graph	PASS
78	30	10	633334	3500.01	DFT-s-OFDM QPSK	1@0	see graph	---
78	30	10	633334	3500.01	DFT-s-OFDM QPSK	1@0	see graph	PASS
78	30	10	633334	3500.01	DFT-s-OFDM QPSK	1@0	see graph	PASS
78	30	10	636332	3544.98	DFT-s-OFDM BPSK	1@0	see graph	---
78	30	10	636332	3544.98	DFT-s-OFDM BPSK	1@0	see graph	PASS
78	30	10	636332	3544.98	DFT-s-OFDM BPSK	1@0	see graph	PASS
78	30	10	636332	3544.98	DFT-s-OFDM QPSK	1@0	see graph	---
78	30	10	636332	3544.98	DFT-s-OFDM QPSK	1@0	see graph	PASS
78	30	10	636332	3544.98	DFT-s-OFDM QPSK	1@0	see graph	PASS
78	30	50	631668	3475.02	DFT-s-OFDM BPSK	1@0	see graph	---
78	30	50	631668	3475.02	DFT-s-OFDM BPSK	1@0	see graph	PASS
78	30	50	631668	3475.02	DFT-s-OFDM BPSK	1@0	see graph	PASS
78	30	50	631668	3475.02	DFT-s-OFDM QPSK	1@0	see graph	---

78	30	50	631668	3475.02	DFT-s-OFDM QPSK	1@0	see graph	PASS
78	30	50	631668	3475.02	DFT-s-OFDM QPSK	1@0	see graph	PASS
78	30	50	633334	3500.01	DFT-s-OFDM BPSK	1@0	see graph	---
78	30	50	633334	3500.01	DFT-s-OFDM BPSK	1@0	see graph	PASS
78	30	50	633334	3500.01	DFT-s-OFDM BPSK	1@0	see graph	PASS
78	30	50	633334	3500.01	DFT-s-OFDM QPSK	1@0	see graph	---
78	30	50	633334	3500.01	DFT-s-OFDM QPSK	1@0	see graph	PASS
78	30	50	633334	3500.01	DFT-s-OFDM QPSK	1@0	see graph	PASS
78	30	50	635000	3525.0	DFT-s-OFDM BPSK	1@0	see graph	---
78	30	50	635000	3525.0	DFT-s-OFDM BPSK	1@0	see graph	PASS
78	30	50	635000	3525.0	DFT-s-OFDM BPSK	1@0	see graph	PASS
78	30	50	635000	3525.0	DFT-s-OFDM QPSK	1@0	see graph	---
78	30	50	635000	3525.0	DFT-s-OFDM QPSK	1@0	see graph	PASS
78	30	50	635000	3525.0	DFT-s-OFDM QPSK	1@0	see graph	PASS
78	30	100	633334	3500.01	DFT-s-OFDM BPSK	1@0	see graph	---
78	30	100	633334	3500.01	DFT-s-OFDM BPSK	1@0	see graph	PASS
78	30	100	633334	3500.01	DFT-s-OFDM BPSK	1@0	see graph	PASS
78	30	100	633334	3500.01	DFT-s-OFDM QPSK	1@0	see graph	---
78	30	100	633334	3500.01	DFT-s-OFDM QPSK	1@0	see graph	PASS
78	30	100	633334	3500.01	DFT-s-OFDM QPSK	1@0	see graph	PASS

N78(10M)\_DFT-s-OFDM\_BPSK\_Edge\_1RB\_Left\_Low\_CH

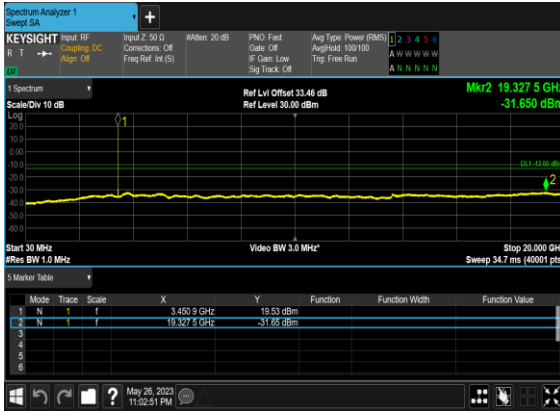

N78(10M)\_DFT-s-OFDM\_BPSK\_Edge\_1RB\_Left\_Low\_CH

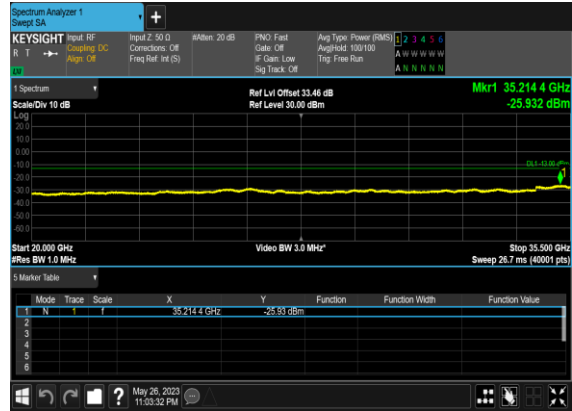

N78(10M)\_DFT-s-OFDM\_QPSK\_Edge\_1RB\_Left\_Low\_CH

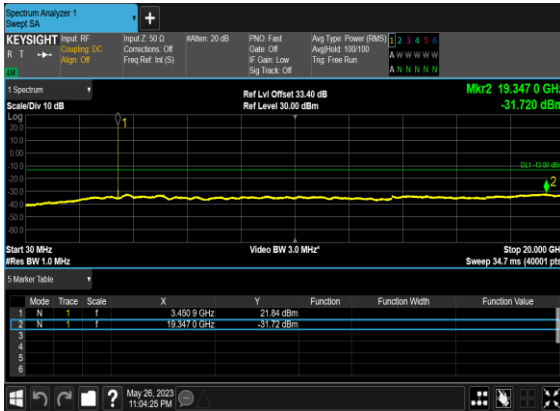

N78(10M)\_DFT-s-OFDM\_QPSK\_Edge\_1RB\_Left\_Low\_CH

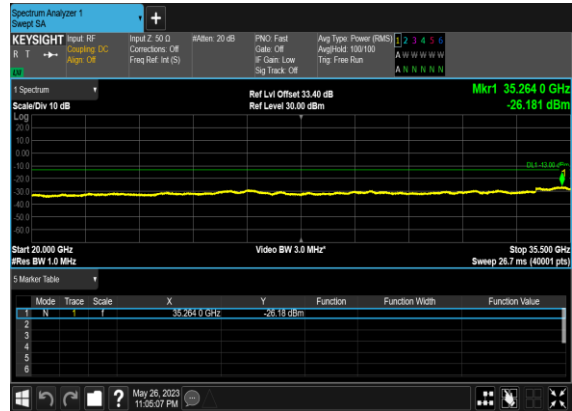

N78(10M)\_DFT-s-OFDM\_BPSK\_Edge\_1RB\_Left\_Mid\_CH

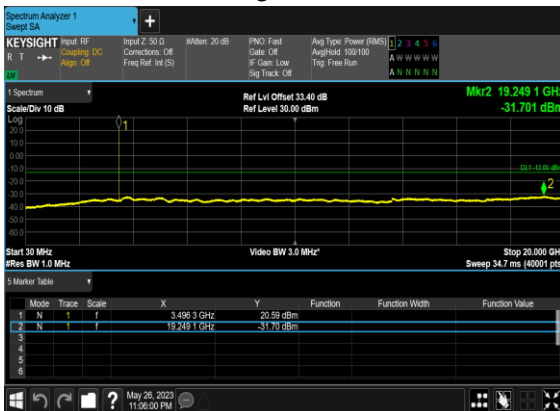

N78(10M)\_DFT-s-OFDM\_BPSK\_Edge\_1RB\_Left\_Mid\_CH

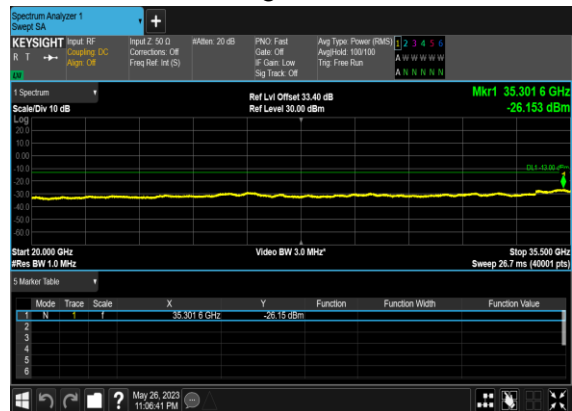

### N78(10M)\_DFT-s-OFDM\_QPSK\_Edge\_1RB\_Left\_Mid\_CH

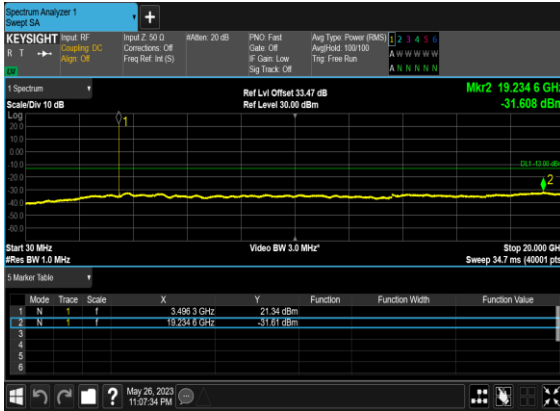

### N78(10M)\_DFT-s-OFDM\_QPSK\_Edge\_1RB\_Left\_Mid\_CH

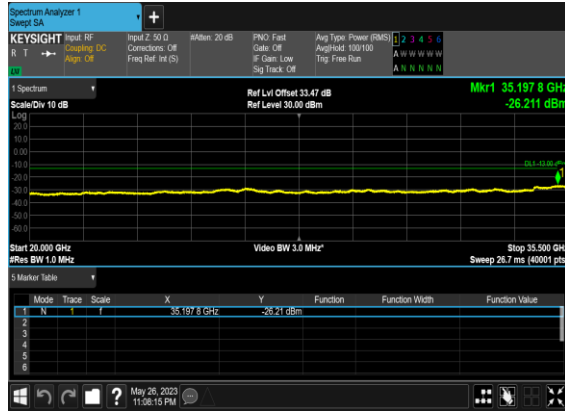

### N78(10M)\_DFT-s-OFDM\_BPSK\_Edge\_1RB\_Left\_High\_CH

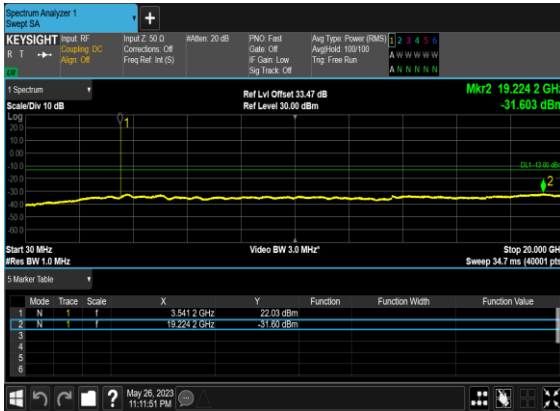

### N78(10M)\_DFT-s-OFDM\_BPSK\_Edge\_1RB\_Left\_High\_CH

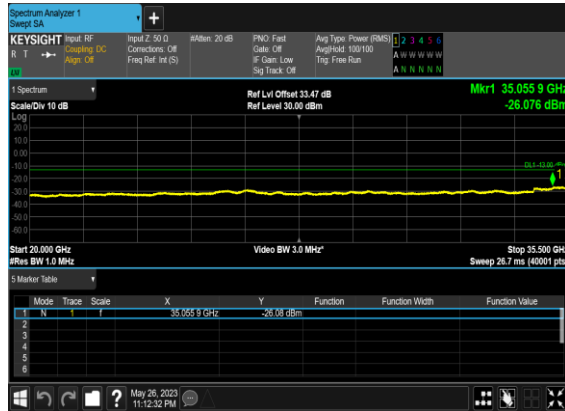

### N78(10M)\_DFT-s-OFDM\_QPSK\_Edge\_1RB\_Left\_High\_CH

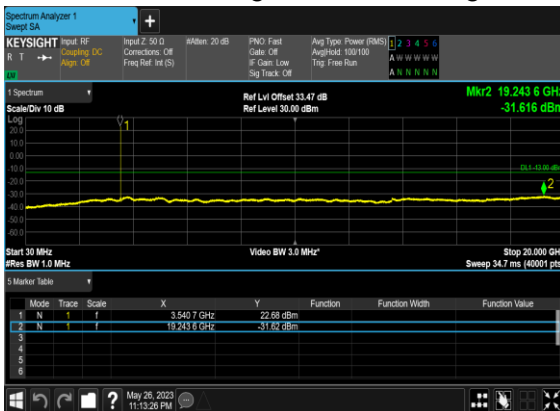

### N78(10M)\_DFT-s-OFDM\_QPSK\_Edge\_1RB\_Left\_High\_CH

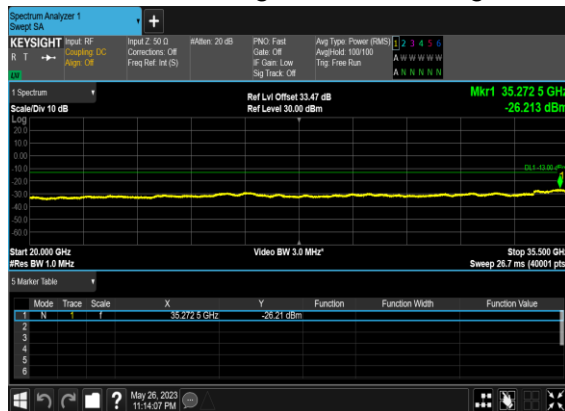



### N78(50M)\_DFT-s-OFDM\_BPSK\_Edge\_1RB\_Left\_Low\_CH

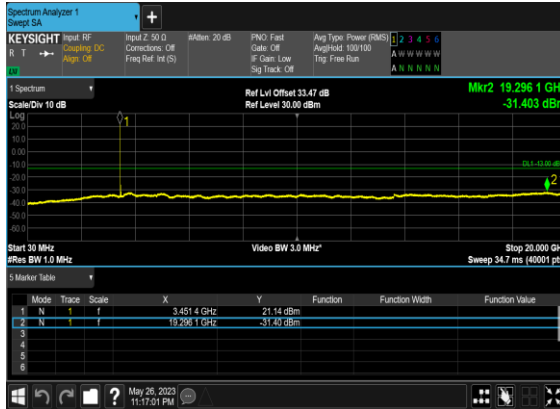

### N78(50M)\_DFT-s-OFDM\_BPSK\_Edge\_1RB\_Left\_Low\_CH

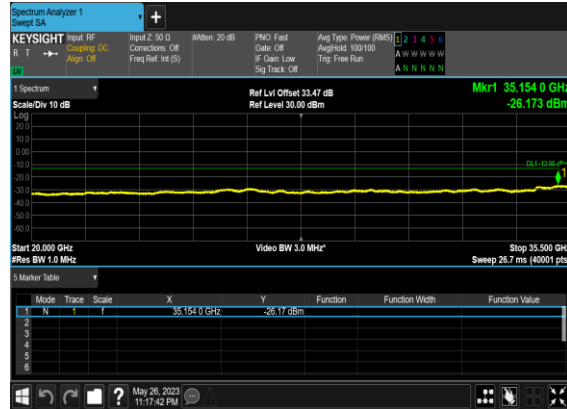

### N78(50M)\_DFT-s-OFDM\_QPSK\_Edge\_1RB\_Left\_Low\_CH

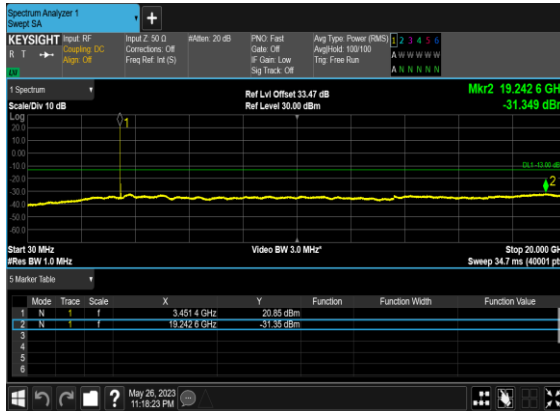

### N78(50M)\_DFT-s-OFDM\_QPSK\_Edge\_1RB\_Left\_Low\_CH

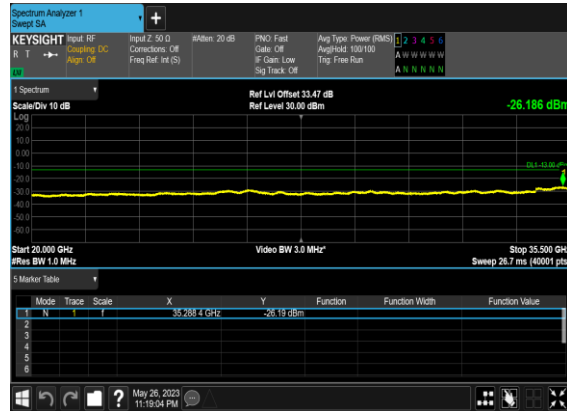

### N78(50M)\_DFT-s-OFDM\_BPSK\_Edge\_1RB\_Left\_Mid\_CH

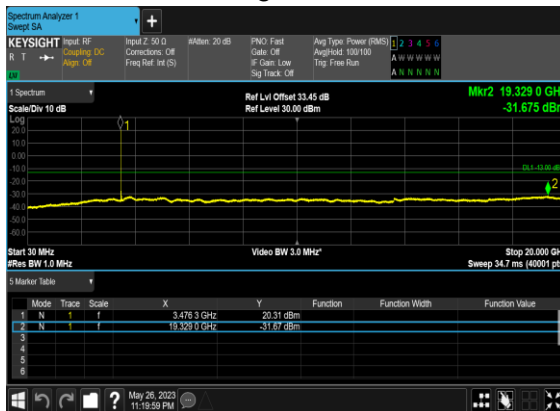

### N78(50M)\_DFT-s-OFDM\_BPSK\_Edge\_1RB\_Left\_Mid\_CH

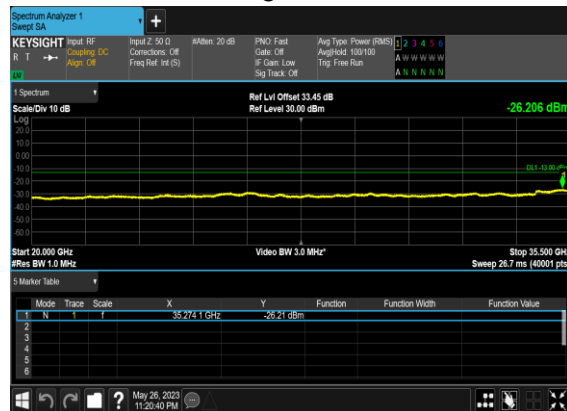

### N78(50M)\_DFT-s-OFDM\_QPSK\_Edge\_1RB\_Left\_Mid\_CH

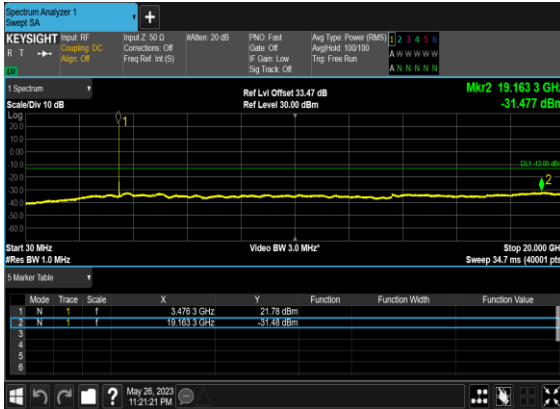

### N78(50M)\_DFT-s-OFDM\_QPSK\_Edge\_1RB\_Left\_Mid\_CH

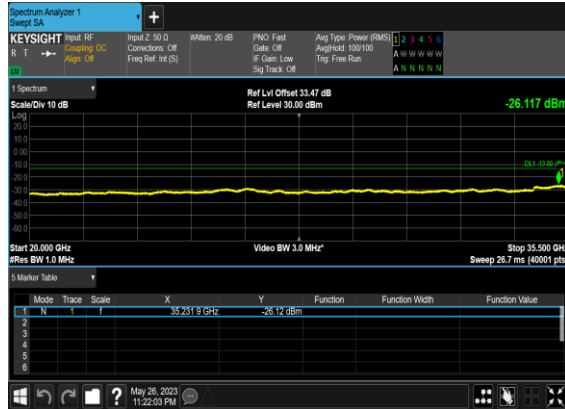

### N78(50M)\_DFT-s-OFDM\_BPSK\_Edge\_1RB\_Left\_High\_CH

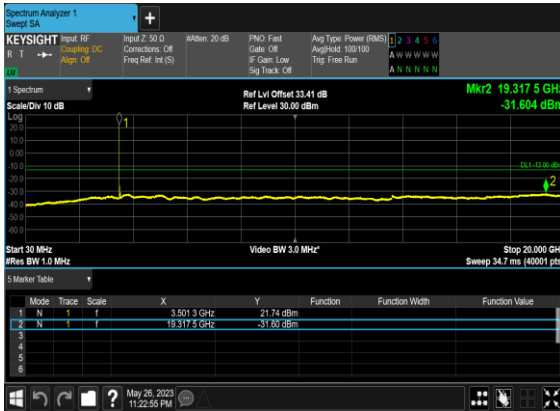

### N78(50M)\_DFT-s-OFDM\_BPSK\_Edge\_1RB\_Left\_High\_CH

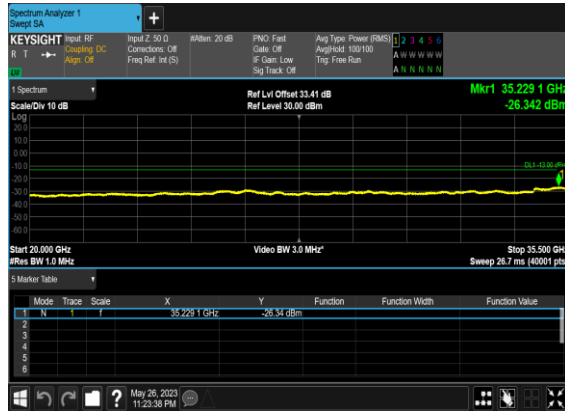

### N78(50M)\_DFT-s-OFDM\_QPSK\_Edge\_1RB\_Left\_High\_CH

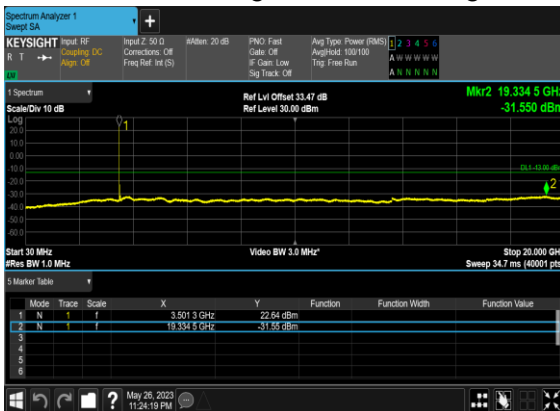

### N78(50M)\_DFT-s-OFDM\_QPSK\_Edge\_1RB\_Left\_High\_CH

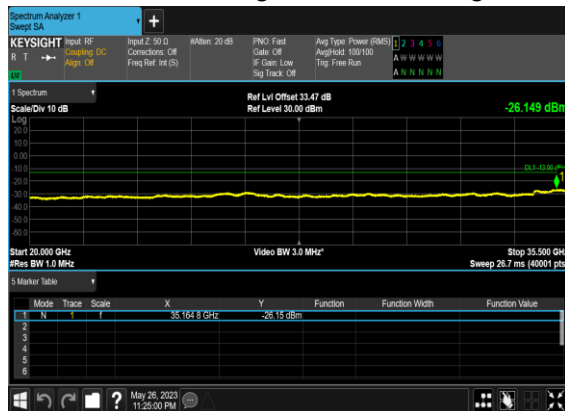

### N78(100M)\_DFT-s-OFDM\_BPSK\_Edge\_1RB\_Left\_Mid\_CH

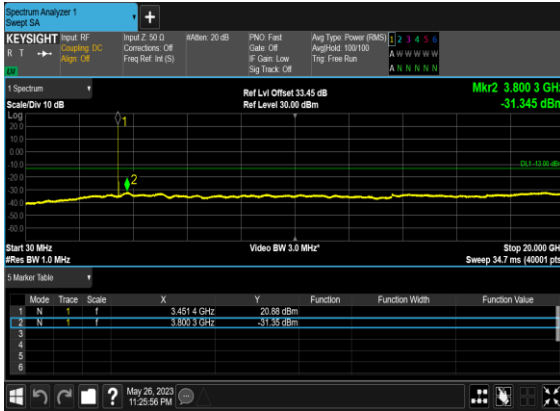

### N78(100M)\_DFT-s-OFDM\_BPSK\_Edge\_1RB\_Left\_Mid\_CH

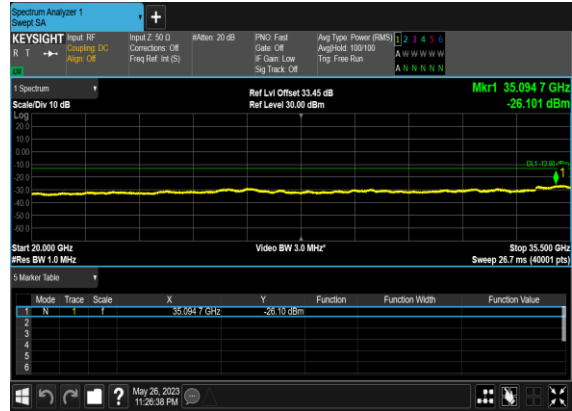

### N78(100M)\_DFT-s-OFDM\_QPSK\_Edge\_1RB\_Left\_Mid\_CH

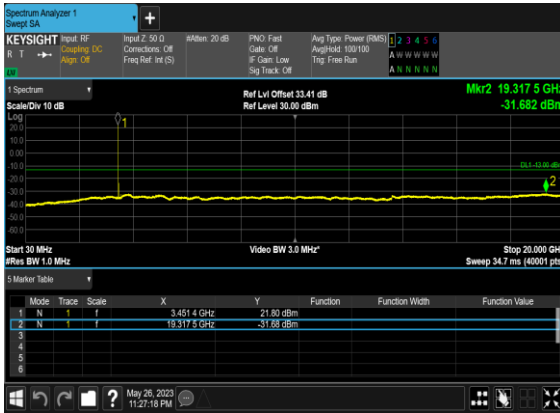

### N78(100M)\_DFT-s-OFDM\_QPSK\_Edge\_1RB\_Left\_Mid\_CH

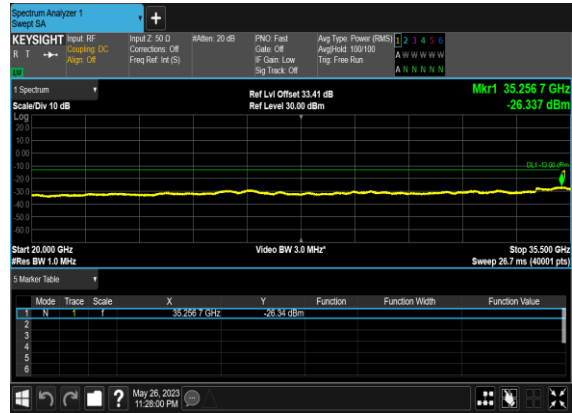

## Conducted Band Edge

NR Band	SCS (kHz)	Bandwidth (MHz)	Arfcn	Freq (MHz)	Modulation	RB	Result	Verdict
78	30	10	630334	3455.01	DFT-s-OFDM BPSK	1@0	see graph	PASS
78	30	10	630334	3455.01	DFT-s-OFDM QPSK	1@0	see graph	PASS
78	30	10	630334	3455.01	DFT-s-OFDM BPSK	24@0	see graph	PASS
78	30	10	630334	3455.01	DFT-s-OFDM QPSK	24@0	see graph	PASS
78	30	10	636332	3544.98	DFT-s-OFDM BPSK	1@23	see graph	PASS
78	30	10	636332	3544.98	DFT-s-OFDM QPSK	1@23	see graph	PASS
78	30	10	636332	3544.98	DFT-s-OFDM BPSK	24@0	see graph	PASS
78	30	10	636332	3544.98	DFT-s-OFDM QPSK	24@0	see graph	PASS
78	30	50	631668	3475.02	DFT-s-OFDM BPSK	1@0	see graph	PASS
78	30	50	631668	3475.02	DFT-s-OFDM QPSK	1@0	see graph	PASS
78	30	50	631668	3475.02	DFT-s-OFDM BPSK	128@0	see graph	PASS
78	30	50	631668	3475.02	DFT-s-OFDM QPSK	128@0	see graph	PASS
78	30	50	635000	3525.0	DFT-s-OFDM BPSK	1@132	see graph	PASS
78	30	50	635000	3525.0	DFT-s-OFDM QPSK	1@132	see graph	PASS
78	30	50	635000	3525.0	DFT-s-OFDM BPSK	128@0	see graph	PASS
78	30	50	635000	3525.0	DFT-s-OFDM QPSK	128@0	see graph	PASS
78	30	100	633334	3500.01	DFT-s-OFDM BPSK	1@0	see graph	PASS
78	30	100	633334	3500.01	DFT-s-OFDM QPSK	1@0	see graph	PASS
78	30	100	633334	3500.01	DFT-s-OFDM BPSK	1@272	see graph	PASS
78	30	100	633334	3500.01	DFT-s-OFDM QPSK	1@272	see graph	PASS
78	30	100	633334	3500.01	DFT-s-OFDM BPSK	270@0	see graph	PASS
78	30	100	633334	3500.01	DFT-s-OFDM QPSK	270@0	see graph	PASS

### N78(10M)\_DFT-s-OFDM\_BPSK\_Edge\_1RB\_Left\_Low\_CH

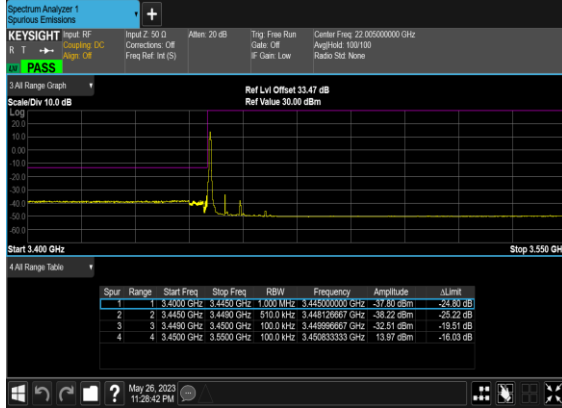

### N78(10M)\_DFT-s-OFDM\_QPSK\_Edge\_1RB\_Left\_Low\_CH

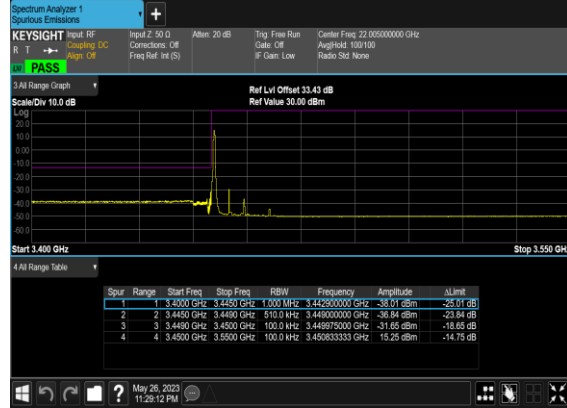

### N78(10M)\_DFT-s-OFDM\_BPSK\_Outer\_Full\_Low\_CH

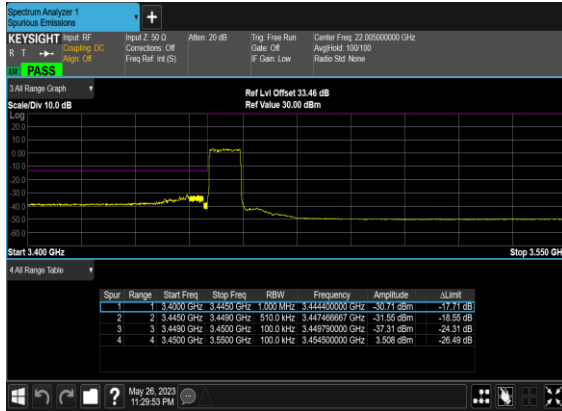

### N78(10M)\_DFT-s-OFDM\_QPSK\_Outer\_Full\_Low\_CH

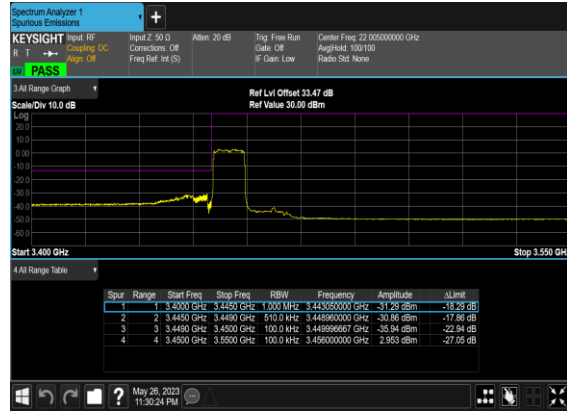

### N78(10M)\_DFT-s-OFDM\_BPSK\_Edge\_1RB\_Right\_High\_CH

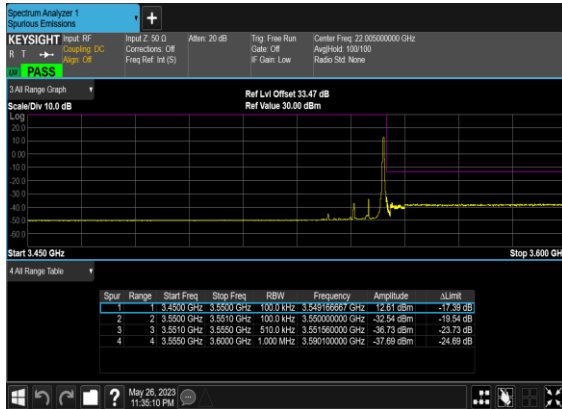

### N78(10M)\_DFT-s-OFDM\_QPSK\_Edge\_1RB\_Right\_High\_CH

