



RF TEST REPORT

Applicant Xiaomi Communications Co., Ltd.
FCC ID 2AFZZNC4L
Product Mobile Phone
Brand Redmi
Model 2212ARNC4L
Report No. R2209A0813-R2
Issue Date November 17, 2022

TA Technology (Shanghai) Co., Ltd. tested the above equipment in accordance with the requirements in **FCC CFR47 Part 2 (2021)/ FCC CFR 47 Part 24E (2021)**. The test results show that the equipment tested is capable of demonstrating compliance with the requirements as documented in this report.

Prepared by: Xu Ying

Approved by: Xu Kai

TA Technology (Shanghai) Co., Ltd.

Building 3, No.145, Jintang Rd, Pudong Shanghai, P.R.China

TEL: +86-021-50791141/2/3

FAX: +86-021-50791141/2/3-8000



TABLE OF CONTENT

1. Test Laboratory	4
1.1. Notes of the test report	4
1.2. Test facility	4
1.3. Testing Location	4
2. General Description of Equipment under Test	5
2.1. Applicant and Manufacturer Information	5
2.2. General information	5
3. Applied Standards	7
4. Test Configuration	8
5. Test Case	10
5.1. RF Power Output and Effective Isotropic Radiated Power	10
5.2. Occupied Bandwidth	11
5.3. Band Edge Compliance	12
5.4. Peak-to-Average Power Ratio (PAPR)	13
5.5. Frequency Stability	14
5.6. Spurious Emissions at Antenna Terminals	16
5.7. Radiated Spurious Emission	17
6. Test Results	20
6.1. RF Power Output and Effective Isotropic Radiated Power	20
6.2. Occupied Bandwidth	30
6.3. Band Edge Compliance	43
6.4. Peak-to-Average Power Ratio (PAPR)	57
6.5. Frequency Stability	59
6.6. Spurious Emissions at Antenna Terminals	63
6.7. Radiated Spurious Emission	68
7. Main Test Instruments	74
ANNEX A: The EUT Appearance	75
ANNEX B: Test Setup Photos	76



Summary of measurement results

No.	Test Case	Clause in FCC rules	Verdict
1	RF Power Output and Effective Isotropic Radiated Power	2.1046 24.232(c)	PASS
2	Occupied Bandwidth	2.1049	PASS
3	Band Edge Compliance	2.1051 /24.238(a)	PASS
4	Peak-to-Average Power Ratio	24.232/KDB 971168 D01(5.7)	PASS
5	Frequency Stability	2.1055 / 24.235	PASS
6	Spurious Emissions at Antenna Terminals	2.1051 / 24.238(a)	PASS
7	Radiated Spurious Emission	2.1053 / 24.238(a)	PASS
Date of Testing: October 11, 2022 ~ October 24, 2022 Date of Sample Received: October 8, 2022			
Note: PASS: The EUT complies with the essential requirements in the standard. FAIL: The EUT does not comply with the essential requirements in the standard. All indications of Pass/Fail in this report are opinions expressed by TA Technology (Shanghai) Co., Ltd. based on interpretations and/or observations of test results. Measurement Uncertainties were not taken into account and are published for informational purposes only.			



1. Test Laboratory

1.1. Notes of the test report

This report shall not be reproduced in full or partial, without the written approval of **TA Technology (Shanghai) Co., Ltd.** The results documented in this report apply only to the tested sample, under the conditions and modes of operation as described herein .Measurement Uncertainties were not taken into account and are published for informational purposes only. This report is written to support regulatory compliance of the applicable standards stated above.

1.2. Test facility

FCC (Designation number: CN1179, Test Firm Registration Number: 446626)

TA Technology (Shanghai) Co., Ltd. has been listed on the US Federal Communications Commission list of test facilities recognized to perform measurements.

A2LA (Certificate Number: 3857.01)

TA Technology (Shanghai) Co., Ltd. has been listed by American Association for Laboratory Accreditation to perform measurement.

1.3. Testing Location

Company: TA Technology (Shanghai) Co., Ltd.
Address: Building 3, No.145, Jintang Rd, Pudong Shanghai, P.R.China
City: Shanghai
Post code: 201201
Country: P. R. China
Contact: Xu Kai
Telephone: +86-021-50791141/2/3
Fax: +86-021-50791141/2/3-8000
Website: <http://www.ta-shanghai.com>
E-mail: xukai@ta-shanghai.com

2. General Description of Equipment under Test

2.1. Applicant and Manufacturer Information

Applicant	Xiaomi Communications Co., Ltd.
Applicant address	#019, 9th Floor, Building 6, 33 Xi'erqi Middle Road, Haidian District, Beijing, China, 100085
Manufacturer	Xiaomi Communications Co., Ltd.
Manufacturer address	#019, 9th Floor, Building 6, 33 Xi'erqi Middle Road, Haidian District, Beijing, China, 100085

2.2. General information

EUT Description			
Model	2212ARNC4L		
IMEI	IMEI 1: 861591060034168 IMEI 2: 861591060034176		
Hardware Version	P1.1		
Software Version	MIUI 13		
Antenna Type	PIFA Antenna		
Antenna Gain	Band	Low Antenna	Upper Antenna
	GSM 1900	0.4 dBi	-1 dBi
	WCDMA Band II	0.4 dBi	-1 dBi
	LTE Band 2	0.4 dBi	-1 dBi
Test Mode(s)	GSM1900; WCDMA Band II; LTE Band 2;		
Test Modulation	(GSM/GPRS)GMSK, (EGPRS) GMSK/ 8PSK; (WCDMA) BPSK, QPSK,16QAM; (LTE) QPSK, 16QAM, 64QAM;		
GPRS Multislot Class	12		
EGPRS Multislot Class	12		
HSDPA UE Category	4		
HSUPA UE Category	5		
LTE Category	5		
Maximum E.I.R.P	GSM 1900:	30.38 dBm	
	WCDMA Band II:	23.72 dBm	
	LTE Band 2:	23.85 dBm	
Rated Power Supply Voltage	3.85V		
Operating Voltage	Minimum: 3.65V Maximum: 4.20V		
Operating Temperature	Lowest: 0°C Highest: +40°C		
Testing Temperature	Lowest: -30°C Highest: +50°C		
Operating Frequency Range(s)	Band	Tx (MHz)	Rx (MHz)



	GSM1900	1850 ~ 1910	1930 ~ 1990
	WCDMA Band II	1850 ~ 1910	1930 ~ 1990
	LTE Band 2	1850 ~ 1910	1930 ~ 1990

Note:

1. The EUT is sent from the applicant to TA and the information of the EUT is declared by the applicant.
2. Low antenna and Upper antenna can't transmit simultaneously.



3. Applied Standards

According to the specifications of the manufacturer, it must comply with the requirements of the following standards:

Test standards:

FCC CFR 47 Part 24E (2021)

FCC CFR47 Part 2 (2021)

Reference standard:

ANSI C63.26-2015

KDB 971168 D01 Power Meas License Digital Systems v03r01

4. Test Configuration

There is more than one SIM card slot, each one should be applied throughout the compliance test respectively, and however, only the worst case (SIM 1) will be recorded in this report.

Radiated measurements are performed by rotating the EUT in three different orthogonal test planes. EUT stand-up position (Z axis), lie-down position (X, Y axis). Receiver antenna polarization (horizontal and vertical), the worst emission was found in position (X axis, vertical polarization for Upper Antenna GSM/WCDMA/LTE Band; X axis, horizontal polarization for Low Antenna GSM/WCDMA Band; X axis, vertical polarization for Low Antenna LTE Band) and the worst case was recorded.

All mode and data rates and positions and RB size and modulations were investigated.

Subsequently, only the worst case emissions are reported.

The following testing in GSM/WCDMA/LTE is set based on the maximum RF Output Power.

Test modes are chosen to be reported as the worst case configuration below:

Test items	Modes/Modulation	
	GSM 1900	WCDMA Band II
RF Power Output and Effective Isotropic Radiated Power	GSM GPRS EGPRS	RMC/AMR HSDPA/HSUPA DC-HSDPA
Occupied Bandwidth	GSM GPRS(1Tx slot) EGPRS(1Tx slot)	RMC
Band Edge Compliance	GSM GPRS(1Tx slot) EGPRS(1Tx slot)	RMC
Peak-to-Average Power Ratio	GSM GPRS(1Tx slot) EGPRS(1Tx slot)	RMC
Frequency Stability	GSM GPRS(1Tx slot) EGPRS(1Tx slot)	RMC
Spurious Emissions at Antenna Terminals	GSM	RMC
Radiated Spurious Emission	GSM	RMC



Test modes are chosen to be reported as the worst case configuration below for LTE Band 2:

Test items	Bandwidth (MHz)						Modulation		RB			Test Channel		
	1.4	3	5	10	15	20	QPSK	16QAM/ 64QAM	1	50%	100%	L	M	H
RF Power Output and Effective Isotropic Radiated Power	○	○	○	○	○	○	○	○	○	○	○	○	○	○
Occupied Bandwidth	○	○	○	○	○	○	○	○	-	-	○	○	○	○
Band Edge Compliance	○	○	○	○	○	○	○	○	○	-	○	○	-	○
Peak-to-Average Power Ratio	○	○	○	○	○	○	○	○	-	-	○	○	○	○
Frequency Stability	○	○	○	○	○	○	○	○	○	-	-	-	○	-
Spurious Emissions at Antenna Terminals	○	○	○	○	○	○	○	-	○	-	-	○	○	○
Radiated Spurious Emission	○	-	○	-	-	○	○	-	○	-	-	-	○	-
Note	1. The mark "○" means that this configuration is chosen for testing. 2. The mark "-" means that this configuration is not testing.													

5. Test Case

5.1.RF Power Output and Effective Isotropic Radiated Power

Ambient condition

Temperature	Relative humidity	Pressure
23°C ~25°C	45%~50%	101.5kPa

Methods of Measurement

During the process of the testing, The EUT was connected to the Base Station Simulator with a known loss. The EUT is controlled by the Base Station Simulator test set to ensure max power transmission with proper modulation.

ERP can then be calculated as follows:

$$\text{EIRP (dBm)} = \text{Output Power (dBm)} + \text{Antenna Gain (dBi)}$$

where:dBd refers to gain relative to an ideal dipole.

$$\text{EIRP (dBm)} = \text{ERP (dBm)} + 2.15 \text{ (dB.)}$$

Test Setup

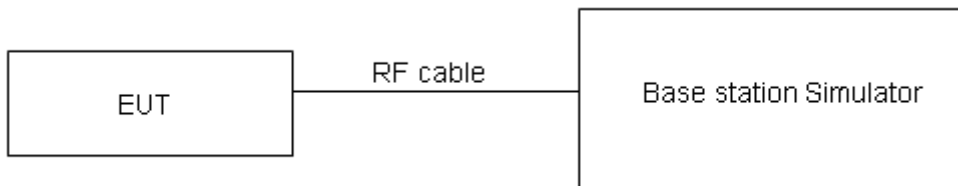

Limits

No specific RF power output requirements in part 2.1046.

Rule Part 24.232(c) Mobile and portable stations are limited to 2 watts EIRP.

Rule Part 24.232(e) Peak transmit power must be measured over any interval of continuous transmission using instrumentation calibrated in terms of an rms-equivalent voltage.

Limit	$\leq 2 \text{ W (33 dBm)}$
-------	-----------------------------

Measurement Uncertainty

The assessed measurement uncertainty to ensure 95% confidence level for the normal distribution is with the coverage factor $k = 2$, $U = 0.4 \text{ dB}$ for RF power output, $k = 2$, $U = 1.19 \text{ dB}$ for EIRP.

Test Results

Refer to the section 6.1 of this report for test data.

5.2.Occupied Bandwidth

Ambient condition

Temperature	Relative humidity	Pressure
23°C ~25°C	45%~50%	101.5kPa

Method of Measurement

The EUT was connected to Spectrum Analyzer and Base Station Simulator via power Splitter. The occupied bandwidth is measured using spectrum analyzer.

RBW is set to $\geq 1\%EBW$, VBW is set to 3x RBW.

99% power and -26dBc occupied bandwidths are recorded. Spectrum analyzer plots are included on the following pages.

Test Setup

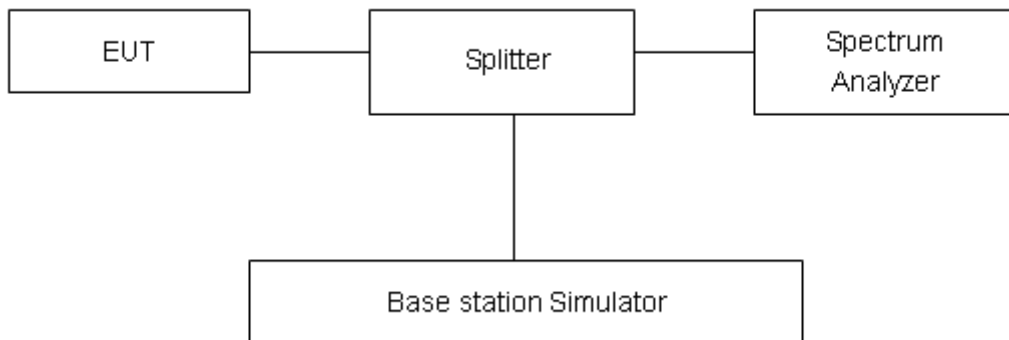

Limits

No specific occupied bandwidth requirements in part 2.1049.

Measurement Uncertainty

The assessed measurement uncertainty to ensure 95% confidence level for the normal distribution is with the coverage factor $k = 2$, $U = 624\text{Hz}$.

Test Results

Refer to the section 6.2 of this report for test data.

5.3. Band Edge Compliance

Ambient condition

Temperature	Relative humidity	Pressure
23°C ~25°C	45%~50%	101.5kPa

Method of Measurement

The EUT was connected to Spectrum Analyzer and Base Station Simulator via power Splitter. The band edge of the lowest and highest channels were measured. The Average detector is used and RBW is set to $\geq 1\%EBW$, VBW is set to 3x RBW.

Spectrum analyzer plots are included on the following pages.

Test Setup

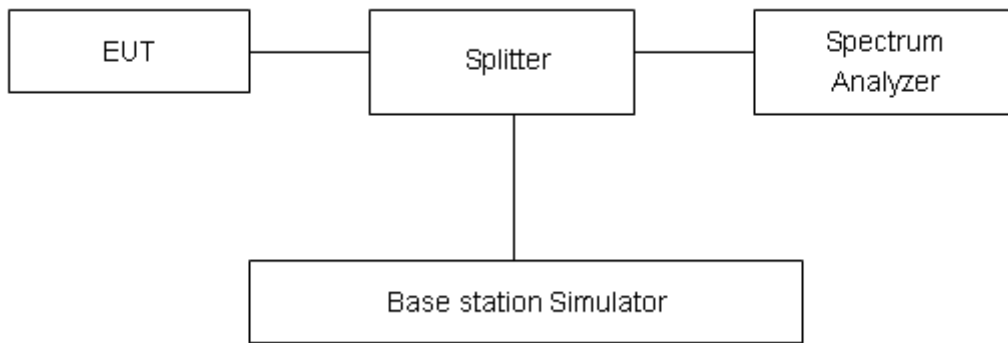

Limits

Rule Part 24.238(a) specifies that “on any frequency outside a licensee’s frequency block, the power of any emission shall be attenuated below the transmitter power (P) by at least $43 + 10 \log_{10} (P)$ dB.”

Limit	-13 dBm
-------	---------

Measurement Uncertainty

The assessed measurement uncertainty to ensure 95% confidence level for the normal distribution is with the coverage factor $k = 1.96$, $U=0.684dB$.

Test Results

Refer to the section 6.3 of this report for test data.

5.4. Peak-to-Average Power Ratio (PAPR)

Ambient condition

Temperature	Relative humidity	Pressure
23°C ~25°C	45%~50%	101.5kPa

Methods of Measurement

Measure the total peak power and record as PPK. And measure the total average power and record as PAvg. Both the peak and average power levels must be expressed in the same logarithmic units (e.g., dBm). Determine the PAPR from:

$$PAPR (dB) = PPK (dBm) - PAvg (dBm).$$

Test Setup

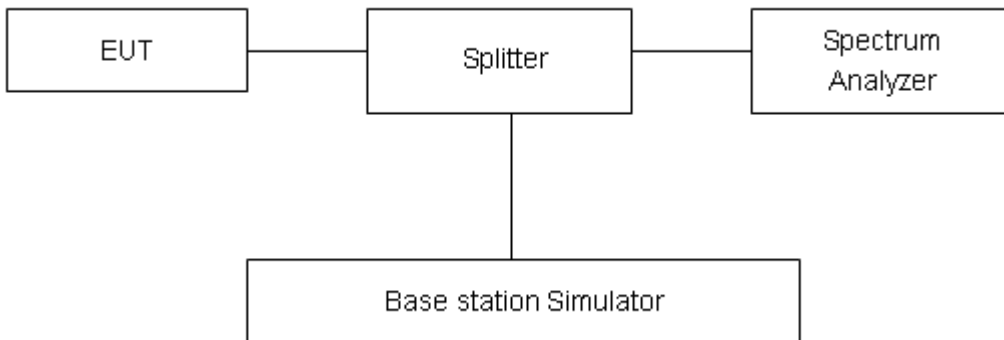

Limits

In measuring transmissions in this band using an average power technique, the peak-to-average ratio (PAR) of the transmission may not exceed 13 dB in 24.232(d).

Measurement Uncertainty

The assessed measurement uncertainty to ensure 95% confidence level for the normal distribution is with the coverage factor $k = 2$, $U = 0.4$ dB.

Test Results

Refer to the section 6.4 of this report for test data.

5.5. Frequency Stability

Ambient condition

Temperature	Relative humidity	Pressure
23°C ~25°C	45%~50%	101.5kPa

Method of Measurement

Frequency Stability (Temperature Variation)

The temperature inside the climate chamber is varied from -30°C to +50°C in 10°C step size,

(1) With all power removed, the temperature was decreased to 0°C and permitted to stabilize for three hours.

(2) Measure the carrier frequency with the test equipment in a “call mode”. These measurements should be made within 1 minute of powering up the mobile station, to prevent significant self warming.

(3) Repeat the above measurements at 10°C increments from -30°C to +50°C. Allow at least 1.5 hours at each temperature, un-powered, before making measurements.

Frequency Stability (Voltage Variation)

The frequency stability shall be measured with variation of primary supply voltage as follows:

Primary Supply Voltage: The primary supply voltage is varied from 85% to 115% of the nominal value for non hand-carried battery and AC powered equipment. For hand-carried, battery-powered equipment, primary supply voltage is reduced to the battery operating end point which shall be specified by the manufacturer.

This transceiver is specified to operate with an input voltage of between 3.65 V and 4.2 V, with a nominal voltage of 3.85V.

Test setup

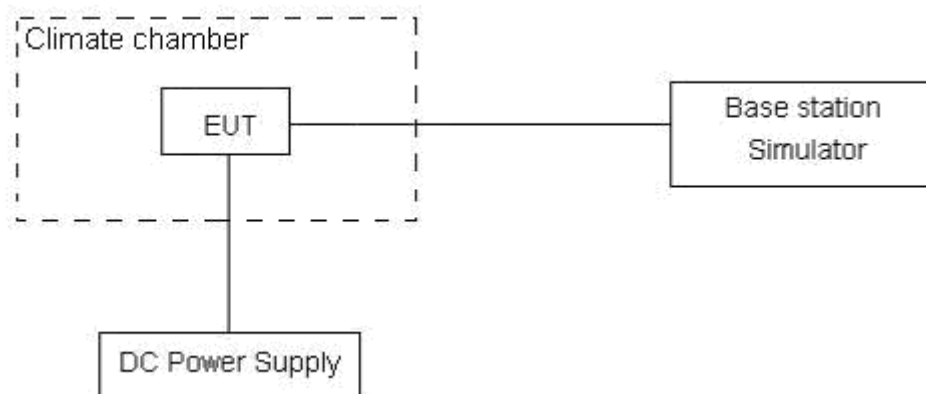



Limits

The frequency stability shall be sufficient to ensure that the fundamental emission stays within the authorized frequency block

Measurement Uncertainty

The assessed measurement uncertainty to ensure 99.75% confidence level for the normal distribution is with the coverage factor $k = 3$, $U = 0.01\text{ppm}$.

Test Results

Refer to the section 6.5 of this report for test data.

5.6. Spurious Emissions at Antenna Terminals

Ambient condition

Temperature	Relative humidity	Pressure
23°C ~25°C	45%~50%	101.5kPa

Method of Measurement

The EUT was connected to Spectrum Analyzer and Base Station Simulator via power Splitter. The measurement is carried out using a spectrum analyzer. The spectrum analyzer scans from 9kHz to the 10th harmonic of the carrier. The peak detector is used.

RBW is set to 1 kHz (0.009MHz~ 0.15 MHz),

RBW is set to 10 kHz (0.15 MHz~ 30 MHz)

RBW is set to 100 kHz (30MHz~1000 MHz)

RBW is set to 1000 kHz (above 1000MHz)

Sweep is set to ATUO.

The modulation mode and RB allocation refer to section 5.1, using the maximum output power configuration.

Test setup

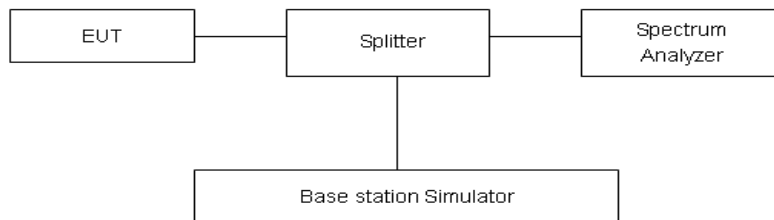

Limits

Rule Part 24.238(a) specifies that “on any frequency outside a licensee’s frequency block, the power of any emission shall be attenuated below the transmitter power (P) by at least 43 + 10 log₁₀ (P) dB.”

Limit	-13 dBm

Measurement Uncertainty

The assessed measurement uncertainty to ensure 99.75% confidence level for the normal distribution is with the coverage factor $k = 1.96$.

Frequency	Uncertainty
9kHz-1GHz	0.684 dB
1GHz-20GHz	1.407 dB

Test Results

Refer to the section 6.6 of this report for test data.

5.7. Radiated Spurious Emission

Ambient condition

Temperature	Relative humidity	Pressure
23°C ~25°C	45%~50%	101.5kPa

Method of Measurement

1. The testing follows FCC KDB 971168 v03r01 Section 5.8 and ANSI C63.26-2015.
2. Below 1GHz: The EUT is placed on a turntable 0.8 meters above the ground in the chamber, 3 meter away from the antenna. The maximal emission value is acquired by adjusting the antenna height, polarisation and turntable azimuth. Normally, the height range of antenna is 1 m to 4 m, the azimuth range of turntable is 0° to 360°, and the receive antenna has two polarizations Vertical (V) and Horizontal (H). Above 1GHz: (Note: the FCC's permission to use 1.5m as an alternative per TCBC Conf call of Dec. 2, 2014.) The EUT is placed on a turntable 1.5 meters above the ground in the chamber, 3 meter away from the antenna. The maximal emission value is acquired by adjusting the antenna height, polarisation and turntable azimuth. Normally, the height range of antenna is 1 m to 4 m, the azimuth range of turntable is 0° to 360°, and the receive antenna has two polarizations Vertical (V) and Horizontal (H).
3. A loop antenna, A log-periodic antenna or horn antenna shall be substituted in place of the EUT. The log-periodic antenna will be driven by a signal generator and the level will be adjusted till the same power value on the spectrum analyzer or receiver. The level of the spurious emissions can be calculated through the level of the signal generator, cable loss, the gain of the substitution antenna and the reading of the spectrum analyzer or receiver.
4. The EUT is then put into continuously transmitting mode at its maximum power level during the test. Set Test Receiver or Spectrum RBW=1MHz, VBW=3MHz, and the maximum value of the receiver should be recorded as (Pr).
5. The EUT shall be replaced by a substitution antenna. In the chamber, an substitution antenna for the frequency band of interest is placed at the reference point of the chamber. An RF Signal source for the frequency band of interest is connected to the substitution antenna with a cable that has been constructed to not interfere with the radiation pattern of the antenna. A power (PMea) is applied to the input of the substitution antenna, and adjust the level of the signal generator output until the value of the receiver reach the previously recorded (Pr). The power of signal source (PMea) is recorded. The test should be performed by rotating the test item and adjusting the receiving antenna polarization.
6. A amplifier should be connected to the Signal Source output port. And the cable should be connect between the Amplifier and the Substitution Antenna. The cable loss (Pcl), the Substitution Antenna Gain (Ga) and the Amplifier Gain (PAg) should be recorded after test.
7. The measurement results are obtained as described below:
$$\text{Power(EIRP)} = \text{PMea} - \text{PAg} - \text{Pcl} + \text{Ga}$$

The measurement results are amend as described below:
$$\text{Power(EIRP)} = \text{PMea} - \text{Pcl} + \text{Ga}$$
8. This value is EIRP since the measurement is calibrated using an antenna of known gain (2.15 dB) and known input power. ERP can be calculated from EIRP by subtracting the gain of the dipole, ERP

= EIRP-2.15dB.

The modulation mode and RB allocation refer to section 5.1, using the maximum output power configuration.

Test setup

9KHz~ 30MHz

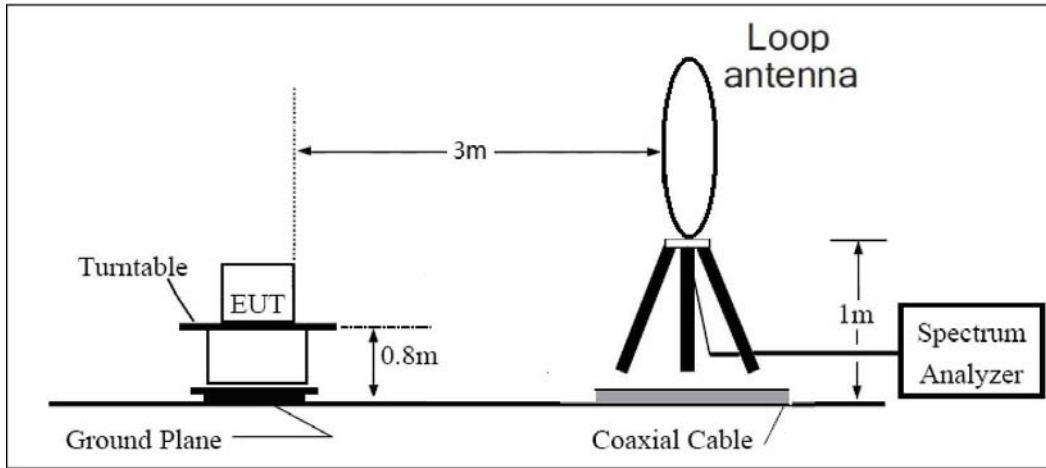

30MHz~ 1GHz

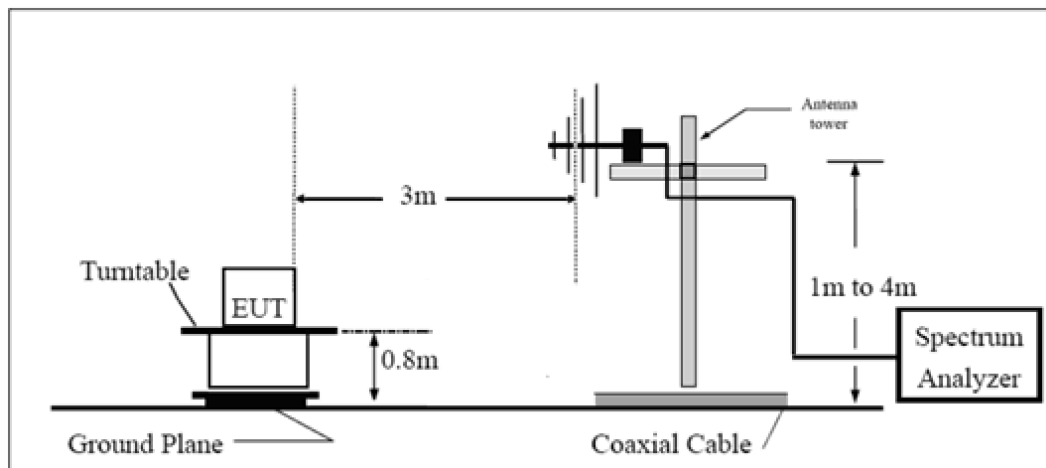

Above 1GHz

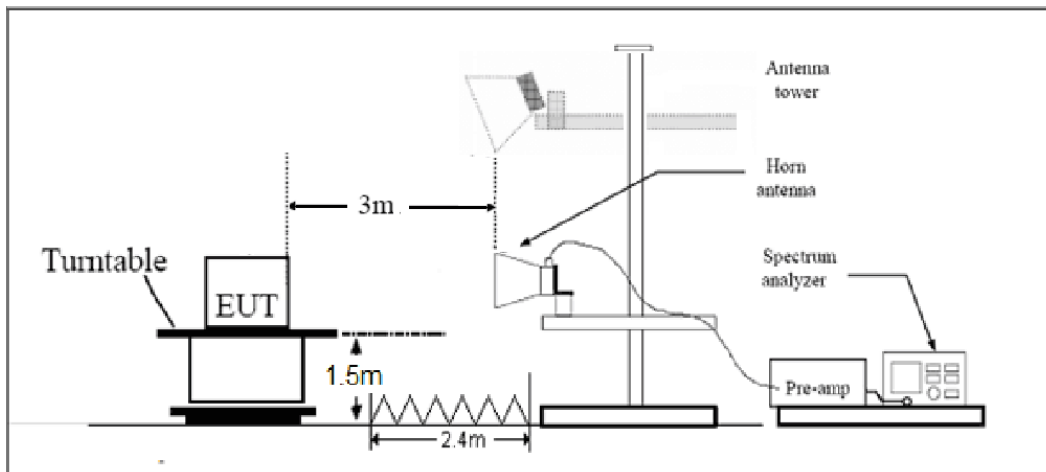

Note: Area side: 2.4mX3.6m

**Limits**

Rule Part 24.238(a) specifies that “on any frequency outside a licensee's frequency block, the power of any emission shall be attenuated below the transmitter power (P) by at least $43 + 10 \log_{10}(P)$ dB.”

Limit	-13 dBm
-------	---------

Measurement Uncertainty

The assessed measurement uncertainty to ensure 95% confidence level for the normal distribution is with the coverage factor $k = 1.96$, $U = 3.55$ dB.

Test Results

Refer to the section 6.7 of this report for test data.

6. Test Results

6.1.RF Power Output and Effective Isotropic Radiated Power

GSM 1900 Low Antenna		Maximum Output Power (dBm)			EIRP(dBm)		
		Channel/Frequency(MHz)			Channel/Frequency(MHz)		
		512/1850.2	661/1880	810/1909.8	512/1850.2	661/1880	810/1909.8
GSM	CS	29.49	29.75	29.64	29.89	30.15	30.04
GPRS/EGPRS (GMSK)	1 Tx Slot	29.70	29.98	29.58	30.10	30.38	29.98
	2 Tx Slots	26.11	26.96	26.82	26.51	27.36	27.22
	3 Tx Slots	22.97	23.85	23.75	23.37	24.25	24.15
	4 Tx Slots	22.02	22.94	22.82	22.42	23.34	23.22
EGPRS (8PSK)	1 Tx Slot	25.43	25.72	25.60	25.83	26.12	26.00
	2 Tx Slots	22.65	22.74	22.61	23.05	23.14	23.01
	3 Tx Slots	19.90	19.73	19.65	20.30	20.13	20.05
	4 Tx Slots	18.80	18.61	18.84	19.20	19.01	19.24

GSM 1900 Upper Antenna		Maximum Output Power (dBm)			EIRP(dBm)		
		Channel/Frequency(MHz)			Channel/Frequency(MHz)		
		512/1850.2	661/1880	810/1909.8	512/1850.2	661/1880	810/1909.8
GSM	CS	29.90	29.75	29.53	28.90	28.75	28.53
GPRS/EGPRS (GMSK)	1 Tx Slot	29.90	29.74	29.52	28.90	28.74	28.52
	2 Tx Slots	26.76	26.54	26.57	25.76	25.54	25.57
	3 Tx Slots	23.59	23.43	23.44	22.59	22.43	22.44
	4 Tx Slots	22.66	22.50	22.53	21.66	21.50	21.53
EGPRS (8PSK)	1 Tx Slot	25.53	25.65	25.62	24.53	24.65	24.62
	2 Tx Slots	22.70	22.75	22.52	21.70	21.75	21.52
	3 Tx Slots	19.62	19.65	19.75	18.62	18.65	18.75
	4 Tx Slots	19.26	19.30	18.83	18.26	18.30	17.83



WCDMA Band II Low Antenna		Maximum Output Power (dBm)			EIRP(dBm)		
		Channel/Frequency(MHz)			Channel/Frequency(MHz)		
		9262/1852.4	9400/1880	9538/1907.6	9262/1852.4	9400/1880	9538/1907.6
RMC	12.2k	23.19	23.19	23.32	23.59	23.59	23.72
AMR	12.2k	23.25	23.07	23.16	23.65	23.47	23.56
HSDPA	Subtest 1	22.17	22.21	22.26	22.57	22.61	22.66
	Subtest 2	22.11	22.19	22.18	22.51	22.59	22.58
	Subtest 3	21.67	21.65	21.78	22.07	22.05	22.18
	Subtest 4	21.69	21.81	21.70	22.09	22.21	22.10
HSUPA	Subtest 1	20.81	20.85	20.96	21.21	21.25	21.36
	Subtest 2	20.19	20.31	20.20	20.59	20.71	20.60
	Subtest 3	20.85	20.53	20.80	21.25	20.93	21.20
	Subtest 4	19.73	19.75	19.78	20.13	20.15	20.18
	Subtest 5	21.35	21.05	21.18	21.75	21.45	21.58
DC-HSDPA	Subtest 1	22.09	22.21	22.30	22.49	22.61	22.70
	Subtest 2	22.05	22.13	22.46	22.45	22.53	22.86
	Subtest 3	21.57	21.73	21.90	21.97	22.13	22.30
	Subtest 4	21.61	21.69	21.74	22.01	22.09	22.14

WCDMA Band II Upper Antenna		Maximum Output Power (dBm)			EIRP(dBm)		
		Channel/Frequency(MHz)			Channel/Frequency(MHz)		
		9262/1852.4	9400/1880	9538/1907.6	9262/1852.4	9400/1880	9538/1907.6
RMC	12.2k	23.02	23.27	23.39	22.02	22.27	22.39
AMR	12.2k	23.02	23.15	23.43	22.02	22.15	22.43
HSDPA	Subtest 1	22.00	22.23	22.31	21.00	21.23	21.31
	Subtest 2	21.98	22.17	22.31	20.98	21.17	21.31
	Subtest 3	21.66	21.83	21.93	20.66	20.83	20.93
	Subtest 4	21.40	21.81	21.81	20.40	20.81	20.81
HSUPA	Subtest 1	20.66	20.73	20.85	19.66	19.73	19.85
	Subtest 2	19.90	20.43	20.47	18.90	19.43	19.47
	Subtest 3	20.56	20.79	20.97	19.56	19.79	19.97
	Subtest 4	19.40	19.83	19.85	18.40	18.83	18.85
	Subtest 5	20.90	21.43	21.35	19.90	20.43	20.35
DC-HSDPA	Subtest 1	21.98	22.25	22.33	20.98	21.25	21.33
	Subtest 2	22.14	22.39	22.33	21.14	21.39	21.33
	Subtest 3	21.50	21.87	21.91	20.50	20.87	20.91
	Subtest 4	21.38	21.67	21.85	20.38	20.67	20.85



LTE Band 2 Low Antenna				Maximum Output Power (dBm)			EIRP(dBm)		
Bandwidth	Modulation	RB allocation	offset	Channel/Frequency(MHz)			Channel/Frequency(MHz)		
				18607/ 1850.7	18900/ 1880	19193/ 1909.3	18607/ 1850.7	18900/ 1880	19193/ 1909.3
1.4MHz	QPSK	1	0	23.14	23.26	23.15	23.54	23.66	23.55
		1	2	23.41	23.41	23.37	23.81	23.81	23.77
		1	5	23.07	23.13	23.20	23.47	23.53	23.60
		3	0	23.19	23.31	23.29	23.59	23.71	23.69
		3	2	23.26	23.33	23.36	23.66	23.73	23.76
		3	3	23.22	23.20	23.25	23.62	23.60	23.65
		6	0	22.24	22.34	22.36	22.64	22.74	22.76
	16QAM	1	0	22.47	22.55	22.45	22.87	22.95	22.85
		1	2	22.69	22.74	22.67	23.09	23.14	23.07
		1	5	22.37	22.42	22.45	22.77	22.82	22.85
		3	0	22.22	22.31	22.36	22.62	22.71	22.76
		3	2	22.35	22.38	22.40	22.75	22.78	22.80
		3	3	22.26	22.28	22.24	22.66	22.68	22.64
		6	0	21.31	21.40	21.40	21.71	21.80	21.80
	64QAM	1	0	21.53	21.49	21.50	21.93	21.89	21.90
		1	2	21.58	21.70	21.72	21.98	22.10	22.12
		1	5	21.25	21.44	21.52	21.65	21.84	21.92
		3	0	21.20	21.33	21.34	21.60	21.73	21.74
		3	2	21.36	21.38	21.39	21.76	21.78	21.79
		3	3	21.25	21.27	21.21	21.65	21.67	21.61
		6	0	20.28	20.37	20.37	20.68	20.77	20.77
Bandwidth	Modulation	RB allocation	offset	Channel/Frequency(MHz)			Channel/Frequency(MHz)		
				18615/ 1851.5	18900/ 1880	19185/ 1908.5	18615/ 1851.5	18900/ 1880	19185/ 1908.5
3MHz	QPSK	1	0	23.16	23.30	23.18	23.56	23.70	23.58
		1	7	23.39	23.44	23.41	23.79	23.84	23.81
		1	14	23.10	23.18	23.24	23.50	23.58	23.64
		8	0	22.29	22.43	22.42	22.69	22.83	22.82
		8	4	22.38	22.43	22.48	22.78	22.83	22.88
		8	7	22.32	22.31	22.35	22.72	22.71	22.75
		15	0	22.24	22.38	22.39	22.64	22.78	22.79
	16QAM	1	0	22.47	22.57	22.48	22.87	22.97	22.88
		1	7	22.69	22.74	22.71	23.09	23.14	23.11
		1	14	22.39	22.46	22.48	22.79	22.86	22.88
		8	0	21.33	21.44	21.48	21.73	21.84	21.88
		8	4	21.46	21.51	21.52	21.86	21.91	21.92
		8	7	21.36	21.40	21.37	21.76	21.80	21.77



	64QAM	15	0	21.34	21.44	21.43	21.74	21.84	21.83	
		1	0	21.56	21.51	21.53	21.96	21.91	21.93	
		1	7	21.61	21.70	21.74	22.01	22.10	22.14	
		1	14	21.27	21.43	21.55	21.67	21.83	21.95	
		8	0	20.31	20.46	20.46	20.71	20.86	20.86	
		8	4	20.47	20.51	20.51	20.87	20.91	20.91	
		8	7	20.35	20.39	20.34	20.75	20.79	20.74	
		15	0	20.31	20.41	20.40	20.71	20.81	20.80	
Bandwidth	Modulation	RB allocation	offset	Channel/Frequency(MHz)			Channel/Frequency(MHz)			
				18625/ 1852.5	18900/ 1880	19175/ 1907.5	18625/ 1852.5	18900/ 1880	19175/ 1907.5	
5MHz	QPSK	1	0	23.13	23.28	23.14	23.53	23.68	23.54	
		1	13	23.37	23.40	23.38	23.77	23.80	23.78	
		1	24	23.07	23.13	23.20	23.47	23.53	23.60	
		12	0	22.26	22.38	22.38	22.66	22.78	22.78	
		12	6	22.36	22.39	22.43	22.76	22.79	22.83	
		12	13	22.30	22.29	22.31	22.70	22.69	22.71	
		25	0	22.24	22.37	22.37	22.64	22.77	22.77	
	16QAM	1	0	22.47	22.53	22.45	22.87	22.93	22.85	
		1	13	22.69	22.72	22.68	23.09	23.12	23.08	
		1	24	22.36	22.44	22.44	22.76	22.84	22.84	
		12	0	21.31	21.40	21.45	21.71	21.80	21.85	
		12	6	21.43	21.46	21.48	21.83	21.86	21.88	
		12	13	21.33	21.35	21.33	21.73	21.75	21.73	
		25	0	21.32	21.40	21.38	21.72	21.80	21.78	
	64QAM	1	0	21.53	21.51	21.50	21.93	21.91	21.90	
		1	13	21.58	21.72	21.71	21.98	22.12	22.11	
		1	24	21.28	21.41	21.51	21.68	21.81	21.91	
		12	0	20.29	20.42	20.47	20.69	20.82	20.87	
		12	6	20.44	20.46	20.47	20.84	20.86	20.87	
		12	13	20.32	20.34	20.30	20.72	20.74	20.70	
		25	0	20.29	20.37	20.35	20.69	20.77	20.75	
	Bandwidth	Modulation	RB allocation	offset	Channel/Frequency(MHz)			Channel/Frequency(MHz)		
					18650/ 1855	18900/ 1880	19150/ 1905	18650/ 1855	18900/ 1880	19150/ 1905
	10MHz	QPSK	1	0	23.15	23.29	23.17	23.55	23.69	23.57
1			25	23.40	23.45	23.42	23.80	23.85	23.82	
1			49	23.09	23.17	23.23	23.49	23.57	23.63	
25			0	22.29	22.43	22.42	22.69	22.83	22.82	
25			13	22.39	22.44	22.47	22.79	22.84	22.87	
25			25	22.32	22.33	22.36	22.72	22.73	22.76	
50			0	22.28	22.39	22.41	22.68	22.79	22.81	
16QAM		1	0	22.51	22.56	22.47	22.91	22.96	22.87	



		1	25	22.73	22.76	22.71	23.13	23.16	23.11
		1	49	22.39	22.46	22.47	22.79	22.86	22.87
		25	0	21.34	21.45	21.49	21.74	21.85	21.89
		25	13	21.45	21.50	21.51	21.85	21.90	21.91
		25	25	21.36	21.40	21.37	21.76	21.80	21.77
		50	0	21.35	21.45	21.42	21.75	21.85	21.82
	64QAM	1	0	21.55	21.50	21.52	21.95	21.90	21.92
		1	25	21.61	21.72	21.74	22.01	22.12	22.14
		1	49	21.27	21.43	21.54	21.67	21.83	21.94
		25	0	20.32	20.47	20.47	20.72	20.87	20.87
		25	13	20.46	20.50	20.50	20.86	20.90	20.90
		25	25	20.35	20.39	20.34	20.75	20.79	20.74
		50	0	20.32	20.42	20.39	20.72	20.82	20.79



Bandwidth	Modulation	RB allocation	offset	Channel/Frequency(MHz)			Channel/Frequency(MHz)		
				18675/ 1857.5	18900/ 1880	19125/ 1902.5	18675/ 1857.5	18900/ 1880	19125/ 1902.5
15MHz	QPSK	1	0	23.14	23.25	23.15	23.54	23.65	23.55
		1	38	23.38	23.44	23.39	23.78	23.84	23.79
		1	74	23.06	23.12	23.19	23.46	23.52	23.59
		36	0	22.27	22.39	22.39	22.67	22.79	22.79
		36	18	22.36	22.39	22.43	22.76	22.79	22.83
		36	39	22.29	22.30	22.32	22.69	22.70	22.72
		75	0	22.26	22.35	22.36	22.66	22.75	22.76
	16QAM	1	0	22.49	22.54	22.45	22.89	22.94	22.85
		1	38	22.71	22.73	22.69	23.11	23.13	23.09
		1	74	22.37	22.42	22.44	22.77	22.82	22.84
		36	0	21.31	21.43	21.46	21.71	21.83	21.86
		36	18	21.42	21.45	21.47	21.82	21.85	21.87
		36	39	21.34	21.36	21.34	21.74	21.76	21.74
		75	0	21.32	21.40	21.38	21.72	21.80	21.78
	64QAM	1	0	21.50	21.48	21.50	21.90	21.88	21.90
		1	38	21.59	21.69	21.72	21.99	22.09	22.12
		1	74	21.28	21.42	21.55	21.68	21.82	21.95
		36	0	20.31	20.49	20.48	20.71	20.89	20.88
		36	18	20.44	20.47	20.49	20.84	20.87	20.89
		36	39	20.33	20.35	20.31	20.73	20.75	20.71
		75	0	20.29	20.37	20.35	20.69	20.77	20.75
Bandwidth	Modulation	RB allocation	offset	Channel/Frequency(MHz)			Channel/Frequency(MHz)		
				18700/ 1860	18900/ 1880	19100/ 1900	18700/ 1860	18900/ 1880	19100/ 1900
20MHz	QPSK	1	0	23.11	23.21	23.12	23.51	23.61	23.52
		1	50	23.37	23.40	23.37	23.77	23.80	23.77
		1	99	23.04	23.11	23.16	23.44	23.51	23.56
		50	0	22.24	22.34	22.35	22.64	22.74	22.75
		50	25	22.34	22.35	22.40	22.74	22.75	22.80
		50	50	22.26	22.25	22.28	22.66	22.65	22.68
		100	0	22.23	22.30	22.32	22.63	22.70	22.72
	16QAM	1	0	22.46	22.50	22.40	22.86	22.90	22.80
		1	50	22.68	22.71	22.65	23.08	23.11	23.05
		1	99	22.34	22.39	22.42	22.74	22.79	22.82
		50	0	21.28	21.39	21.43	21.68	21.79	21.83
		50	25	21.39	21.43	21.44	21.79	21.83	21.84
		50	50	21.31	21.31	21.30	21.71	21.71	21.70
		100	0	21.30	21.36	21.35	21.70	21.76	21.75
	64QAM	1	0	21.48	21.44	21.45	21.88	21.84	21.85



		1	50	21.55	21.67	21.68	21.95	22.07	22.08
		1	99	21.22	21.36	21.49	21.62	21.76	21.89
		50	0	20.26	20.41	20.41	20.66	20.81	20.81
		50	25	20.40	20.43	20.43	20.80	20.83	20.83
		50	50	20.30	20.30	20.27	20.70	20.70	20.67
		100	0	20.27	20.33	20.32	20.67	20.73	20.72

LTE Band 2 Upper Antenna				Maximum Output Power (dBm)			EIRP(dBm)		
Bandwidth	Modulation	RB allocation	offset	Channel/Frequency(MHz)			Channel/Frequency(MHz)		
				18607/ 1850.7	18900/ 1880	19193/ 1909.3	18607/ 1850.7	18900/ 1880	19193/ 1909.3
1.4MHz	QPSK	1	0	23.17	23.24	23.19	22.17	22.24	22.19
		1	2	23.44	23.42	23.44	22.44	22.42	22.44
		1	5	23.09	23.07	23.25	22.09	22.07	22.25
		3	0	23.19	23.31	23.34	22.19	22.31	22.34
		3	2	23.26	23.35	23.40	22.26	22.35	22.40
		3	3	23.19	23.26	23.29	22.19	22.26	22.29
		6	0	22.19	22.38	22.42	21.19	21.38	21.42
	16QAM	1	0	22.48	22.54	22.57	21.48	21.54	21.57
		1	2	22.65	22.79	22.74	21.65	21.79	21.74
		1	5	22.37	22.40	22.58	21.37	21.40	21.58
		3	0	22.24	22.34	22.38	21.24	21.34	21.38
		3	2	22.36	22.39	22.44	21.36	21.39	21.44
		3	3	22.25	22.30	22.29	21.25	21.30	21.29
		6	0	21.29	21.39	21.45	20.29	20.39	20.45
	64QAM	1	0	21.54	21.52	21.41	20.54	20.52	20.41
		1	2	21.76	21.71	21.64	20.76	20.71	20.64
		1	5	21.41	21.43	21.40	20.41	20.43	20.40
		3	0	21.24	21.30	21.41	20.24	20.30	20.41
		3	2	21.36	21.38	21.42	20.36	20.38	20.42
		3	3	21.24	21.29	21.30	20.24	20.29	20.30
		6	0	20.30	20.38	20.44	19.30	19.38	19.44
Bandwidth	Modulation	RB allocation	offset	Channel/Frequency(MHz)			Channel/Frequency(MHz)		
				18615/ 1851.5	18900/ 1880	19185/ 1908.5	18615/ 1851.5	18900/ 1880	19185/ 1908.5
3MHz	QPSK	1	0	23.19	23.28	23.22	22.19	22.28	22.22
		1	7	23.42	23.45	23.48	22.42	22.45	22.48
		1	14	23.12	23.12	23.29	22.12	22.12	22.29
		8	0	22.29	22.43	22.47	21.29	21.43	21.47
		8	4	22.38	22.45	22.52	21.38	21.45	21.52
		8	7	22.29	22.37	22.39	21.29	21.37	21.39
		15	0	22.19	22.42	22.45	21.19	21.42	21.45
	16QAM	1	0	22.48	22.56	22.60	21.48	21.56	21.60



		1	7	22.65	22.79	22.78	21.65	21.79	21.78
		1	14	22.39	22.44	22.61	21.39	21.44	21.61
		8	0	21.35	21.47	21.50	20.35	20.47	20.50
		8	4	21.47	21.52	21.56	20.47	20.52	20.56
		8	7	21.35	21.42	21.42	20.35	20.42	20.42
		15	0	21.32	21.43	21.48	20.32	20.43	20.48
	64QAM	1	0	21.57	21.54	21.44	20.57	20.54	20.44
		1	7	21.79	21.71	21.66	20.79	20.71	20.66
		1	14	21.43	21.42	21.43	20.43	20.42	20.43
		8	0	20.35	20.43	20.53	19.35	19.43	19.53
		8	4	20.47	20.51	20.54	19.47	19.51	19.54
		8	7	20.34	20.41	20.43	19.34	19.41	19.43
		15	0	20.33	20.42	20.47	19.33	19.42	19.47
Bandwidth	Modulation	RB allocation	offset	Channel/Frequency(MHz)			Channel/Frequency(MHz)		
				18625/1852.5	18900/1880	19175/1907.5	18625/1852.5	18900/1880	19175/1907.5
5MHz	QPSK	1	0	23.16	23.26	23.18	22.16	22.26	22.18
		1	13	23.40	23.41	23.45	22.40	22.41	22.45
		1	24	23.09	23.07	23.25	22.09	22.07	22.25
		12	0	22.26	22.38	22.43	21.26	21.38	21.43
		12	6	22.36	22.41	22.47	21.36	21.41	21.47
		12	13	22.27	22.35	22.35	21.27	21.35	21.35
		25	0	22.19	22.41	22.43	21.19	21.41	21.43
	16QAM	1	0	22.48	22.52	22.57	21.48	21.52	21.57
		1	13	22.65	22.77	22.75	21.65	21.77	21.75
		1	24	22.36	22.42	22.57	21.36	21.42	21.57
		12	0	21.33	21.43	21.47	20.33	20.43	20.47
		12	6	21.44	21.47	21.52	20.44	20.47	20.52
		12	13	21.32	21.37	21.38	20.32	20.37	20.38
		25	0	21.30	21.39	21.43	20.30	20.39	20.43
	64QAM	1	0	21.54	21.54	21.41	20.54	20.54	20.41
		1	13	21.76	21.73	21.63	20.76	20.73	20.63
		1	24	21.44	21.40	21.39	20.44	20.40	20.39
		12	0	20.33	20.39	20.54	19.33	19.39	19.54
		12	6	20.44	20.46	20.50	19.44	19.46	19.50
		12	13	20.31	20.36	20.39	19.31	19.36	19.39
		25	0	20.31	20.38	20.42	19.31	19.38	19.42
Bandwidth	Modulation	RB allocation	offset	Channel/Frequency(MHz)			Channel/Frequency(MHz)		
				18650/1855	18900/1880	19150/1905	18650/1855	18900/1880	19150/1905
10MHz	QPSK	1	0	23.18	23.27	23.21	22.18	22.27	22.21
		1	25	23.43	23.46	23.49	22.43	22.46	22.49
		1	49	23.11	23.11	23.28	22.11	22.11	22.28



		25	0	22.29	22.43	22.47	21.29	21.43	21.47	
		25	13	22.39	22.46	22.51	21.39	21.46	21.51	
		25	25	22.29	22.39	22.40	21.29	21.39	21.40	
		50	0	22.23	22.43	22.47	21.23	21.43	21.47	
	16QAM	1	0	22.52	22.55	22.59	21.52	21.55	21.59	
		1	25	22.69	22.81	22.78	21.69	21.81	21.78	
		1	49	22.39	22.44	22.60	21.39	21.44	21.60	
		25	0	21.36	21.48	21.51	20.36	20.48	20.51	
		25	13	21.46	21.51	21.55	20.46	20.51	20.55	
		25	25	21.35	21.42	21.42	20.35	20.42	20.42	
		50	0	21.33	21.44	21.47	20.33	20.44	20.47	
	64QAM	1	0	21.56	21.53	21.43	20.56	20.53	20.43	
		1	25	21.79	21.73	21.66	20.79	20.73	20.66	
		1	49	21.43	21.42	21.42	20.43	20.42	20.42	
		25	0	20.36	20.44	20.54	19.36	19.44	19.54	
		25	13	20.46	20.50	20.53	19.46	19.50	19.53	
		25	25	20.34	20.41	20.43	19.34	19.41	19.43	
		50	0	20.34	20.43	20.46	19.34	19.43	19.46	
	Bandwidth	Modulation	RB allocation	offset	Channel/Frequency(MHz)			Channel/Frequency(MHz)		
					18675/ 1857.5	18900/ 1880	19125/ 1902.5	18675/ 1857.5	18900/ 1880	19125/ 1902.5
	15MHz	QPSK	1	0	23.17	23.23	23.19	22.17	22.23	22.19
1			38	23.41	23.45	23.46	22.41	22.45	22.46	
1			74	23.08	23.06	23.24	22.08	22.06	22.24	
36			0	22.27	22.39	22.44	21.27	21.39	21.44	
36			18	22.36	22.41	22.47	21.36	21.41	21.47	
36			39	22.26	22.36	22.36	21.26	21.36	21.36	
75			0	22.21	22.39	22.42	21.21	21.39	21.42	
16QAM		1	0	22.50	22.53	22.57	21.50	21.53	21.57	
		1	38	22.67	22.78	22.76	21.67	21.78	21.76	
		1	74	22.37	22.40	22.57	21.37	21.40	21.57	
		36	0	21.33	21.46	21.48	20.33	20.46	20.48	
		36	18	21.43	21.46	21.51	20.43	20.46	20.51	
		36	39	21.33	21.38	21.39	20.33	20.38	20.39	
		75	0	21.30	21.39	21.43	20.30	20.39	20.43	
64QAM		1	0	21.51	21.51	21.41	20.51	20.51	20.41	
		1	38	21.77	21.70	21.64	20.77	20.70	20.64	
		1	74	21.44	21.41	21.43	20.44	20.41	20.43	
		36	0	20.35	20.46	20.55	19.35	19.46	19.55	
		36	18	20.44	20.47	20.52	19.44	19.47	19.52	
		36	39	20.32	20.37	20.40	19.32	19.37	19.40	
		75	0	20.31	20.38	20.42	19.31	19.38	19.42	



Bandwidth	Modulation	RB allocation	offset	Channel/Frequency(MHz)			Channel/Frequency(MHz)		
				18700/ 1860	18900/ 1880	19100/ 1900	18700/ 1860	18900/ 1880	19100/ 1900
20MHz	QPSK	1	0	23.14	23.19	23.16	22.14	22.19	22.16
		1	50	23.40	23.41	23.44	22.40	22.41	22.44
		1	99	23.06	23.05	23.21	22.06	22.05	22.21
		50	0	22.24	22.34	22.40	21.24	21.34	21.40
		50	25	22.34	22.37	22.44	21.34	21.37	21.44
		50	50	22.23	22.31	22.32	21.23	21.31	21.32
		100	0	22.18	22.34	22.38	21.18	21.34	21.38
	16QAM	1	0	22.47	22.49	22.52	21.47	21.49	21.52
		1	50	22.64	22.76	22.72	21.64	21.76	21.72
		1	99	22.34	22.37	22.55	21.34	21.37	21.55
		50	0	21.30	21.42	21.45	20.30	20.42	20.45
		50	25	21.40	21.44	21.48	20.40	20.44	20.48
		50	50	21.30	21.33	21.35	20.30	20.33	20.35
		100	0	21.28	21.35	21.40	20.28	20.35	20.40
	64QAM	1	0	21.49	21.47	21.36	20.49	20.47	20.36
		1	50	21.73	21.68	21.60	20.73	20.68	20.60
		1	99	21.38	21.35	21.37	20.38	20.35	20.37
		50	0	20.30	20.38	20.48	19.30	19.38	19.48
		50	25	20.40	20.43	20.46	19.40	19.43	19.46
		50	50	20.29	20.32	20.36	19.29	19.32	19.36
		100	0	20.29	20.34	20.39	19.29	19.34	19.39

6.2.Occupied Bandwidth

Mode	Channel	Frequency (MHz)	99% Power Bandwidth (MHz)	-26dBc Bandwidth(MHz)
GSM 1900 (GMSK)	512	1850.2	0.2464	0.3171
	661	1880.0	0.2466	0.3163
	810	1909.8	0.2460	0.3167
GPRS 1900 (GMSK)	512	1850.2	0.2475	0.3123
	661	1880.0	0.2468	0.3174
	810	1909.8	0.2449	0.3175
EGPRS 1900 (8PSK)	512	1850.2	0.2466	0.3159
	661	1880.0	0.2471	0.3107
	810	1909.8	0.2469	0.3128

Mode	Channel	Frequency (MHz)	99% Power Bandwidth (MHz)	-26dBc Bandwidth(MHz)
WCDMA Band II	9262	1852.4	4.1609	4.6690
	9400	1880	4.1626	4.6800
	9538	1907.6	4.1655	4.6830

LTE Band 2						
RB	Modulation	Bandwidth (MHz)	Channel	Frequency (MHz)	99% Power Bandwidth(MHz)	-26dBc Bandwidth(MHz)
100%	QPSK	1.4	18607	1850.7	1.1017	1.2850
			18900	1880.0	1.0900	1.3190
			19193	1909.3	1.0909	1.3060
		3	18615	1851.5	2.6849	2.9120
			18900	1880	2.6899	2.9140
			19185	1908.5	2.6902	2.9230
		5	18625	1852.5	4.5277	4.8750
			18900	1880	4.5054	4.8670
			19175	1907.5	4.5054	4.9290
		10	18650	1855	8.9934	9.7620
			18900	1880	8.9653	9.7220
			19150	1905	8.9848	9.6920
		15	18675	1857.5	13.4980	14.5060
			18900	1880	13.4660	14.2470



		19125	1902.5	13.4400	14.7430		
		20	18700	1860	17.9280	19.1210	
			18900	1880	17.9800	19.3670	
			19100	1900	17.9570	19.2700	
	16QAM	1.4	18607	1850.7	1.0954	1.2750	
			18900	1880.0	1.0961	1.2940	
			19193	1909.3	1.0949	1.2770	
		3	18615	1851.5	2.6889	2.9330	
			18900	1880	2.6902	2.9370	
			19185	1908.5	2.6947	2.9520	
		5	18625	1852.5	4.5056	4.8900	
			18900	1880	4.5019	4.9110	
			19175	1907.5	4.5146	4.8850	
		10	18650	1855	8.9867	9.6510	
			18900	1880	8.9806	9.6990	
			19150	1905	8.9739	9.6620	
		15	18675	1857.5	13.4690	14.4570	
			18900	1880	13.4590	14.4270	
			19125	1902.5	13.4610	14.5010	
		20	18700	1860	17.9590	19.3570	
			18900	1880	17.9530	19.4120	
			19100	1900	17.9330	19.3030	
		64QAM	1.4	18607	1850.7	1.0900	1.2930
				18900	1880.0	1.0973	1.3040
				19193	1909.3	1.0908	1.2650
			3	18615	1851.5	2.6825	2.9020
				18900	1880	2.6875	2.9080
				19185	1908.5	2.6862	2.9000
	5		18625	1852.5	4.5032	4.8800	
			18900	1880	4.5032	4.9040	
19175			1907.5	4.5106	4.9120		
10	18650		1855	8.9841	9.7760		
	18900		1880	8.9738	9.7260		
	19150		1905	8.9891	9.5950		
15	18675		1857.5	13.4630	14.5740		
	18900		1880	13.4500	14.4320		
	19125		1902.5	13.4310	14.4820		
20	18700		1860	18.0000	19.2450		
	18900		1880	17.9570	19.2240		
	19100		1900	17.9590	19.2770		

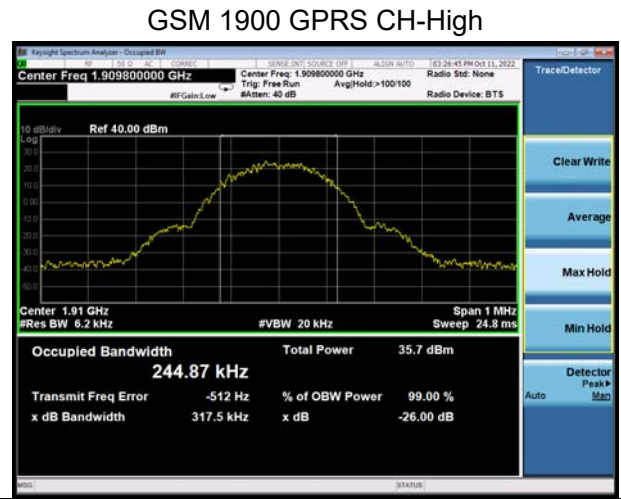
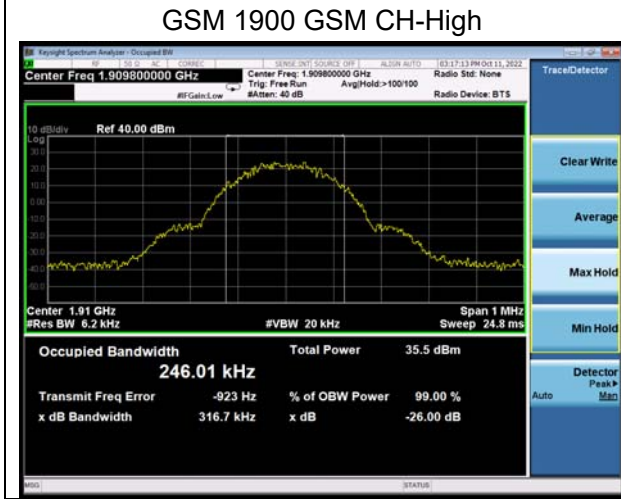
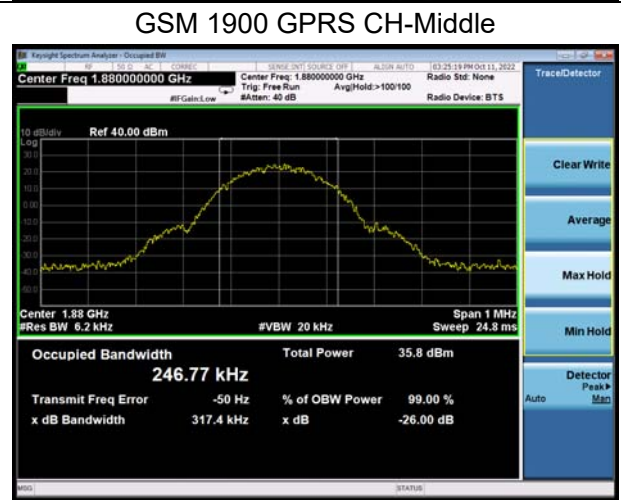
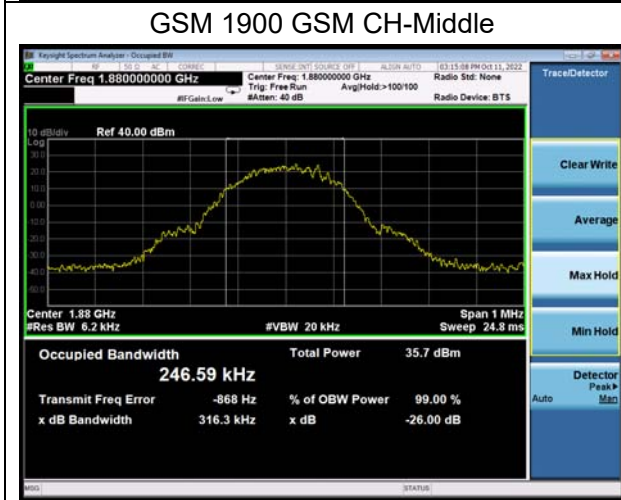
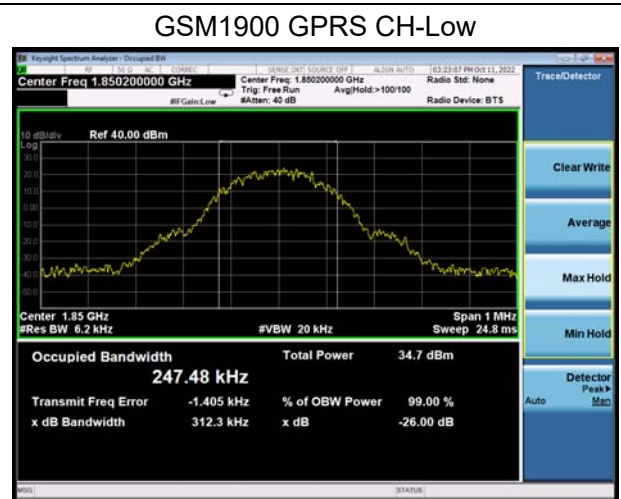
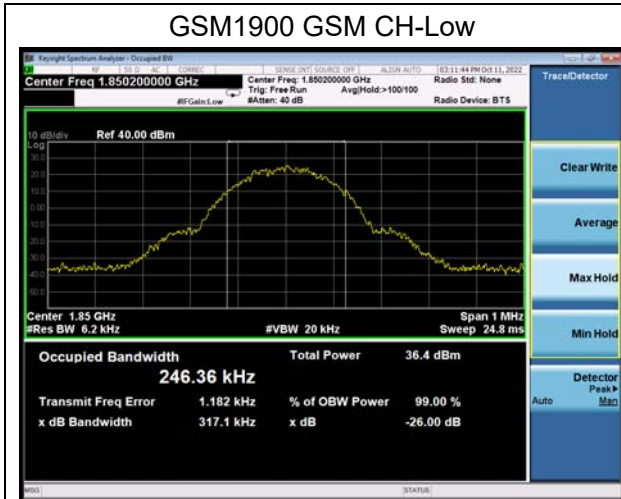

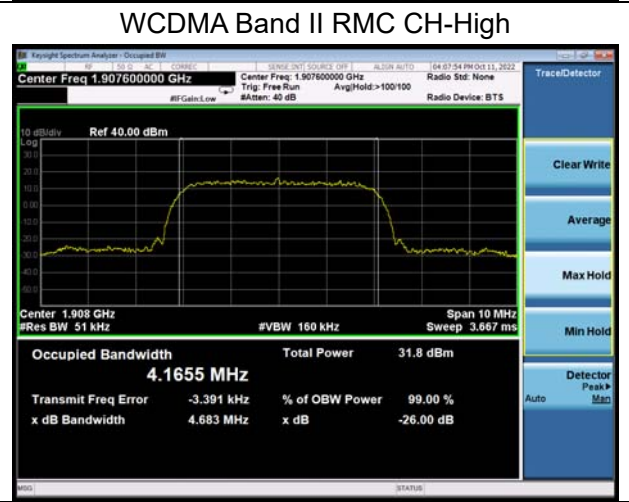
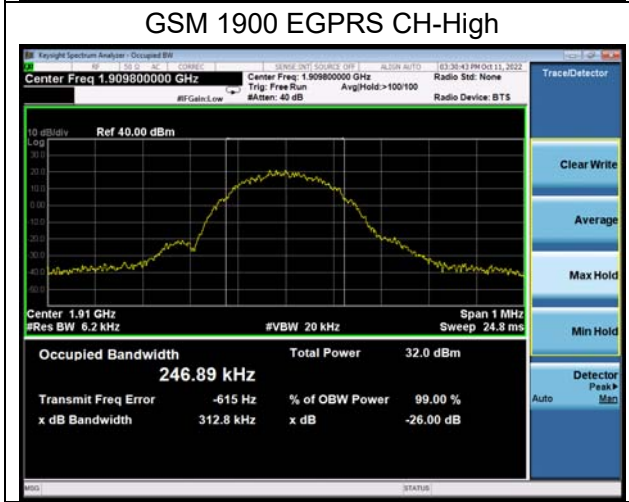
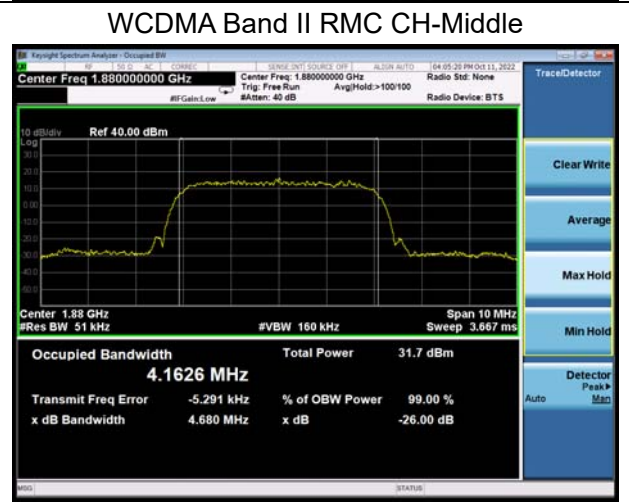
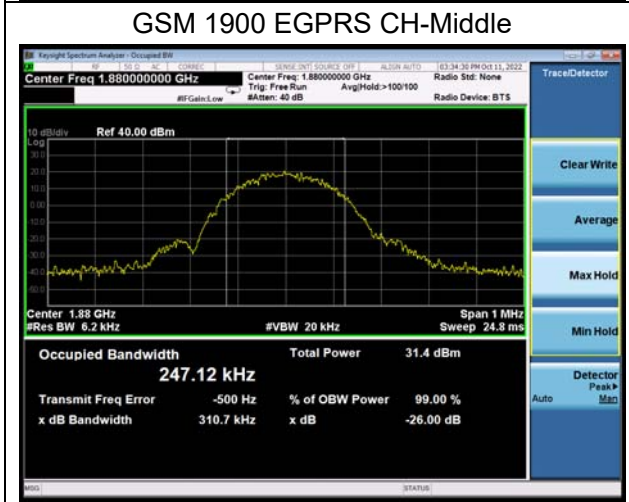
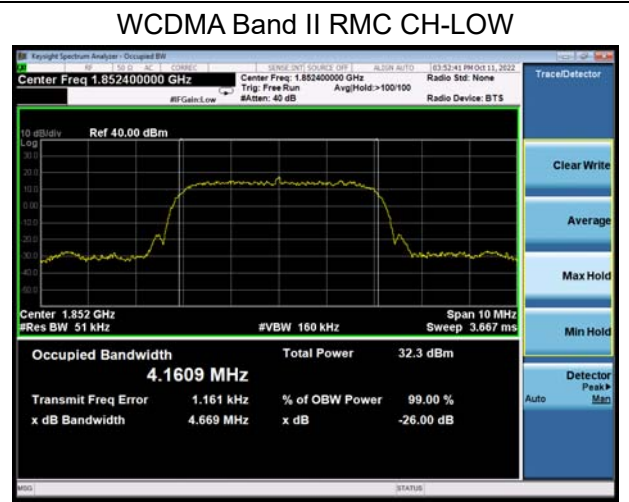
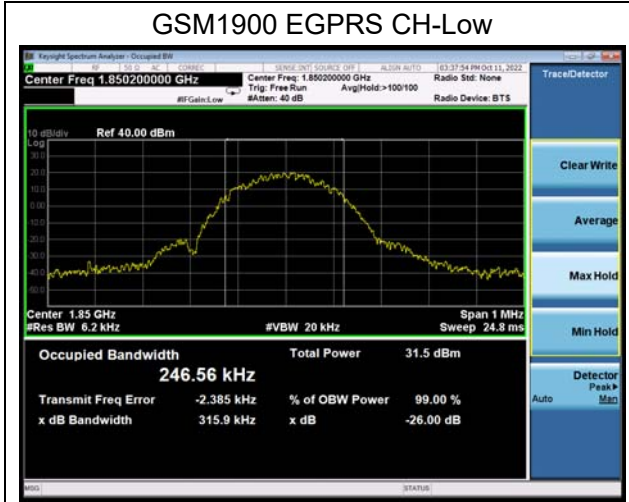

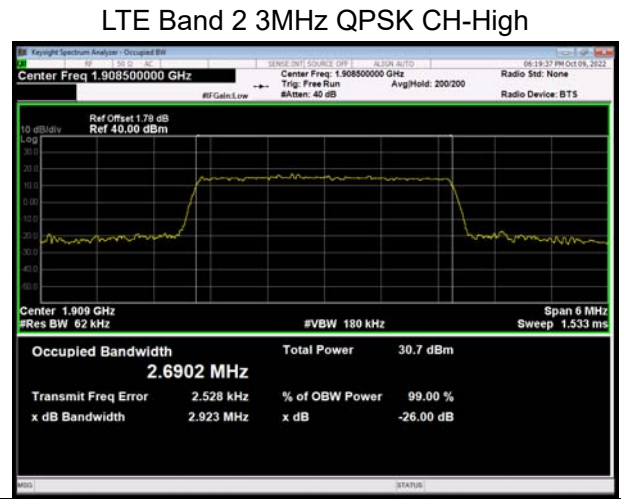
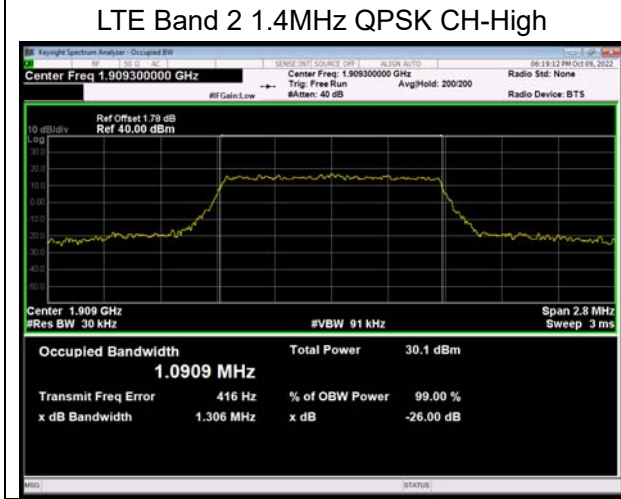
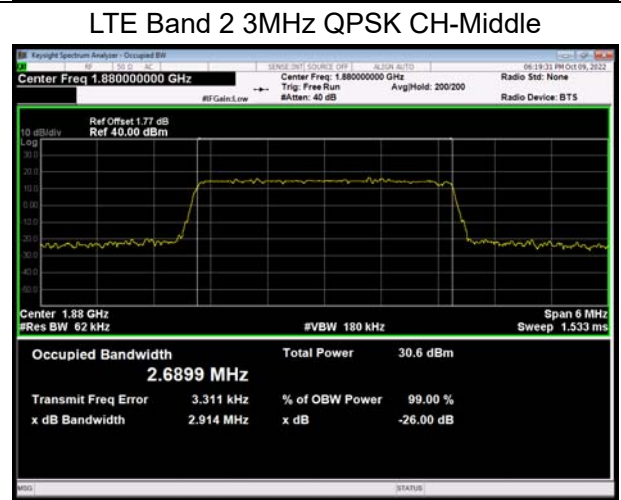
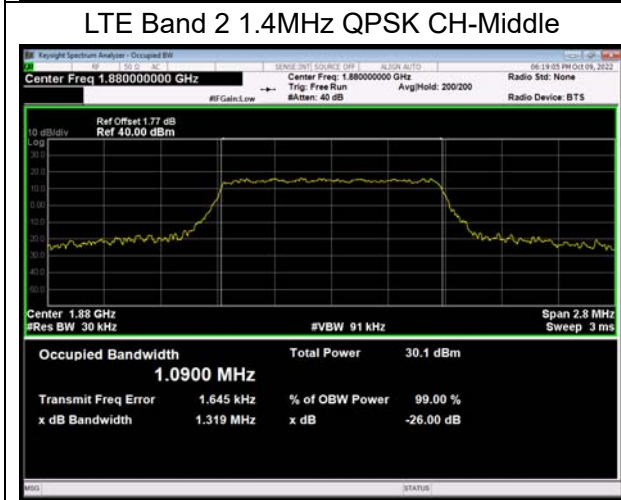
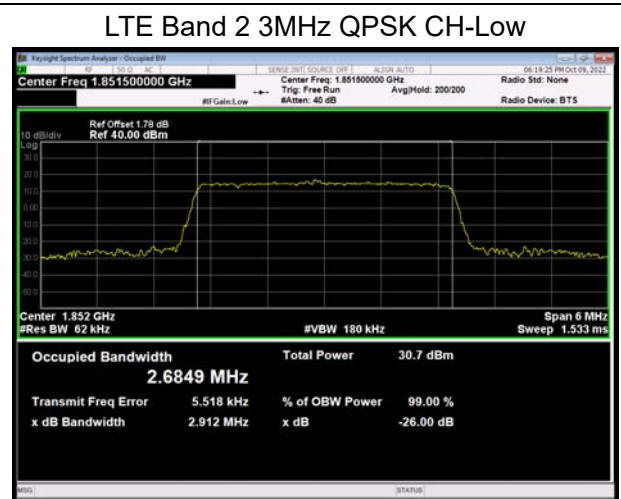
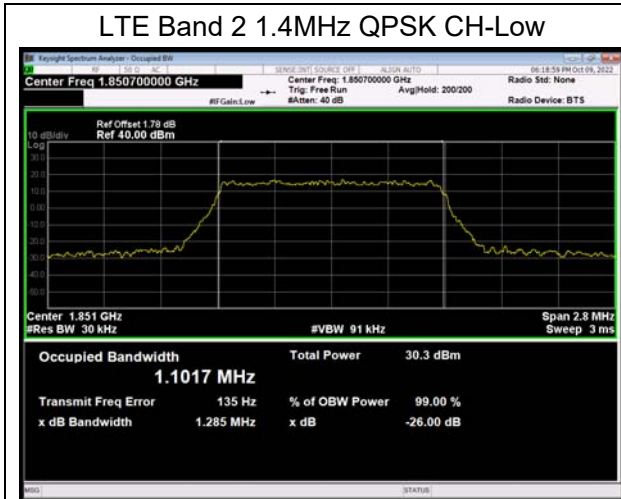

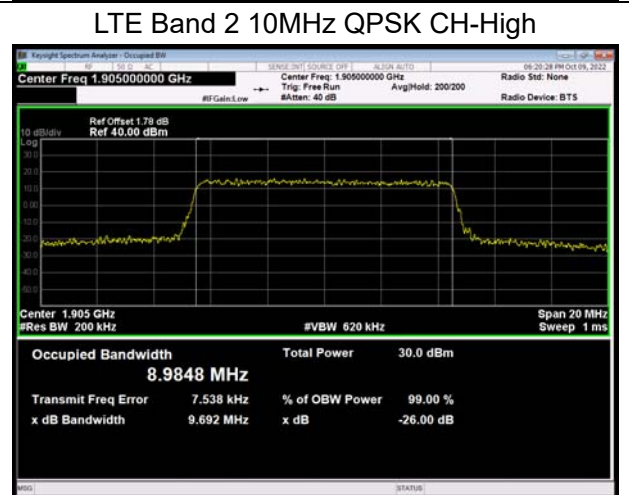
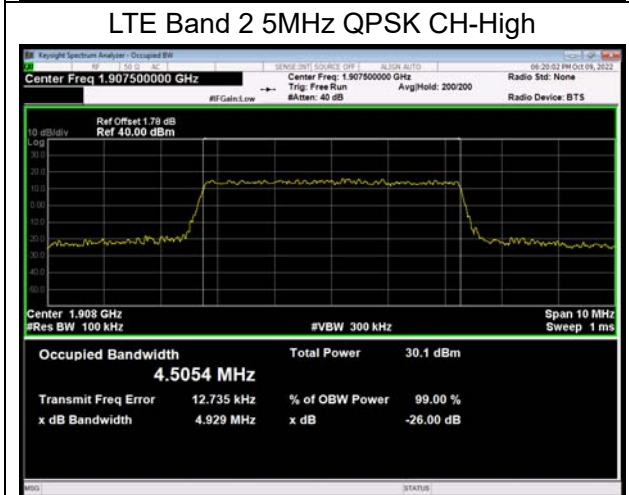
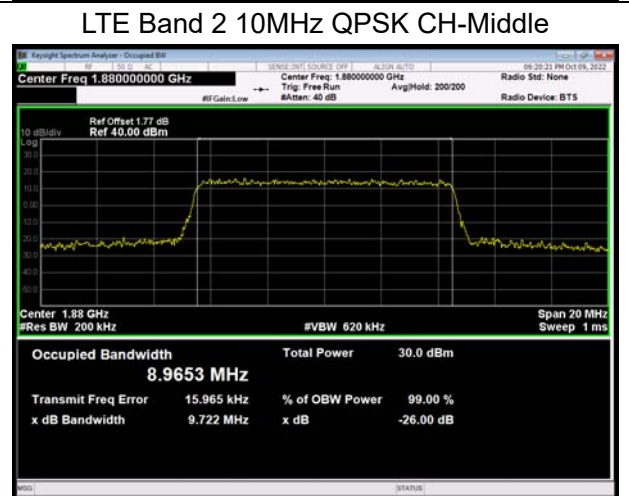
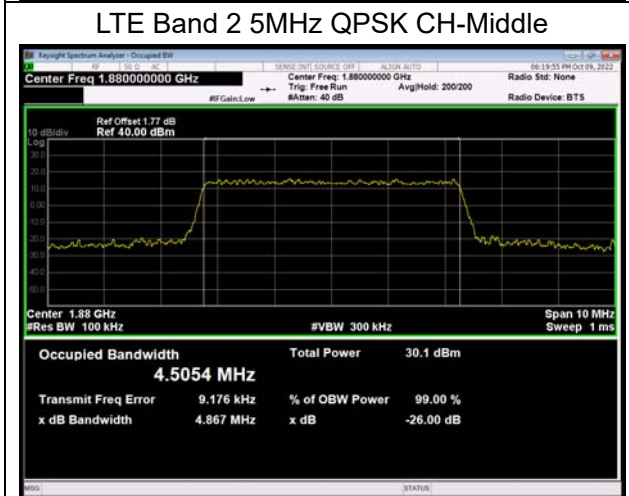
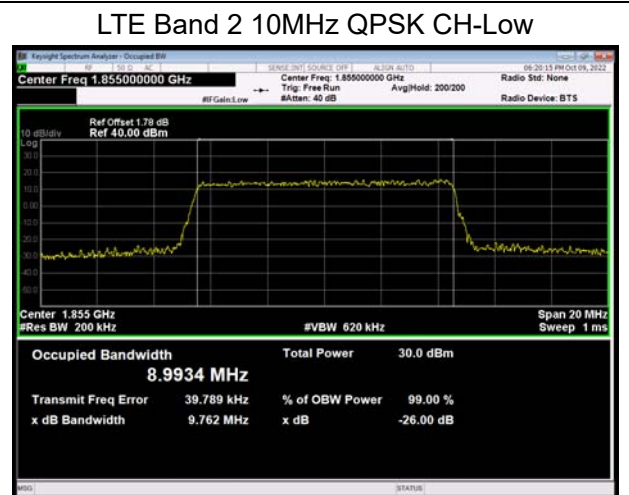
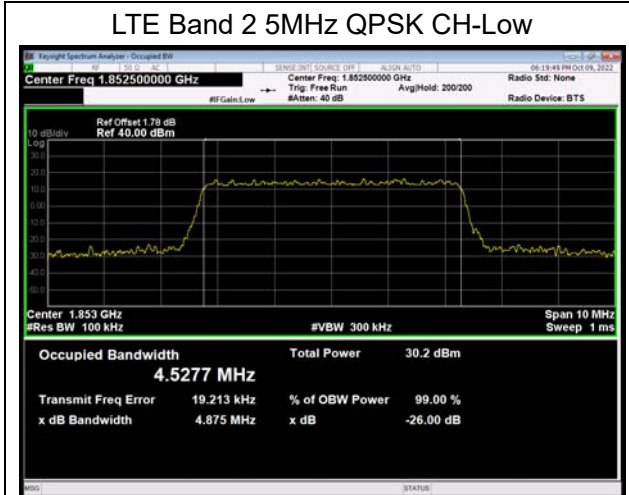

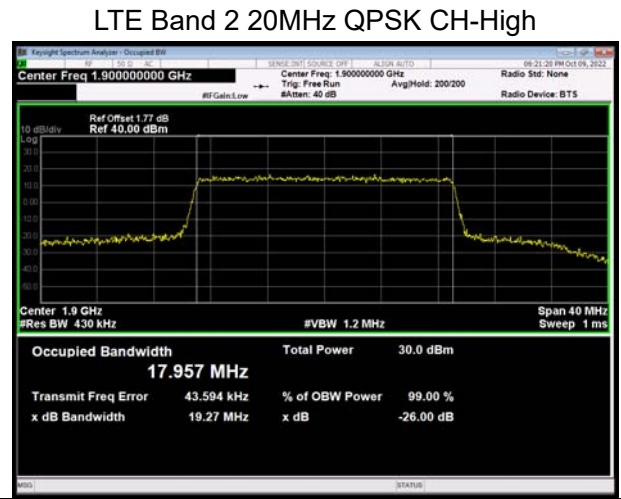
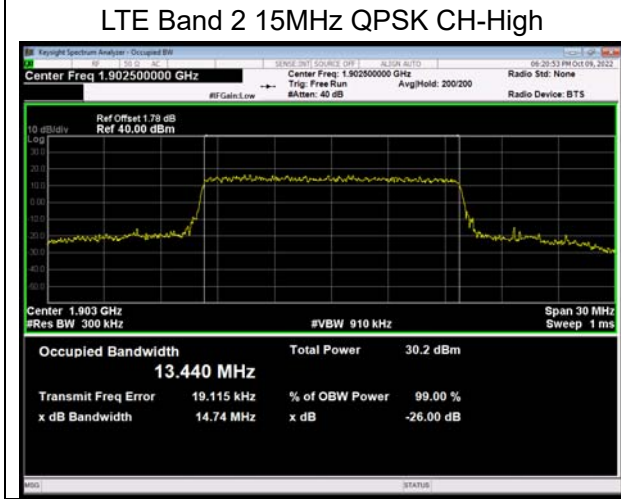
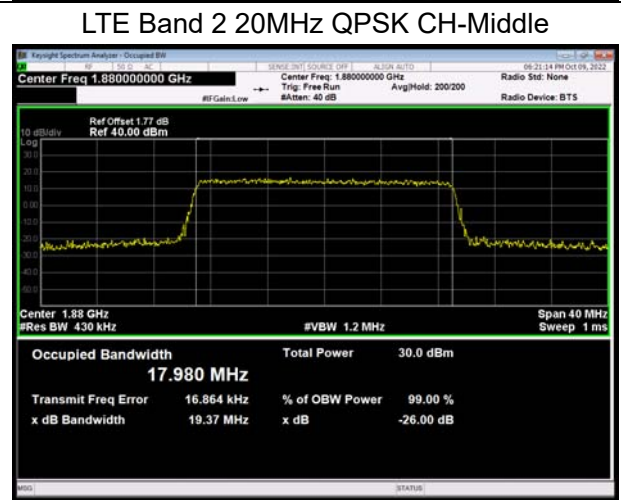
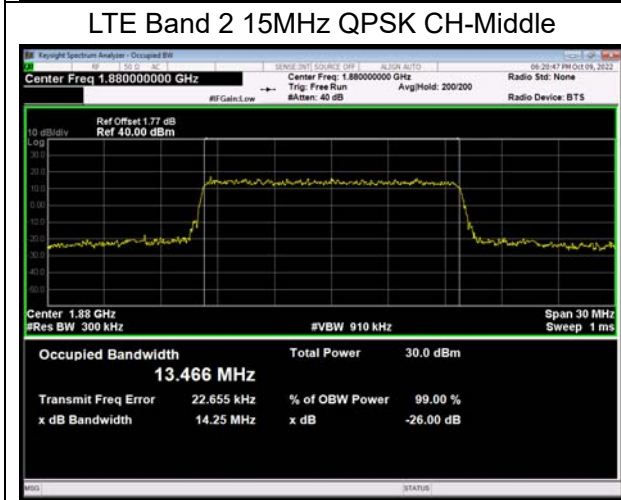
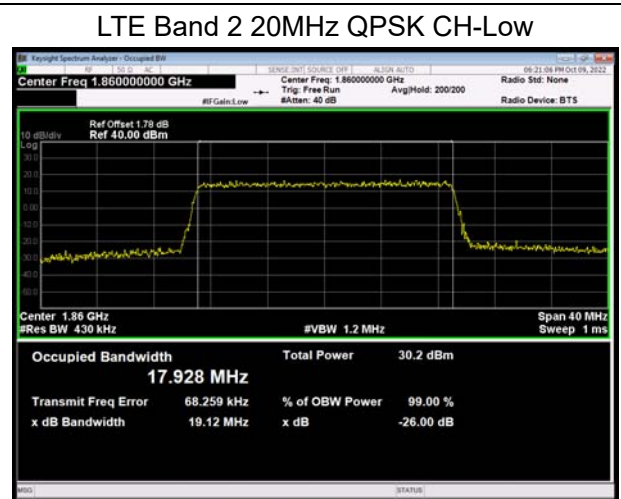
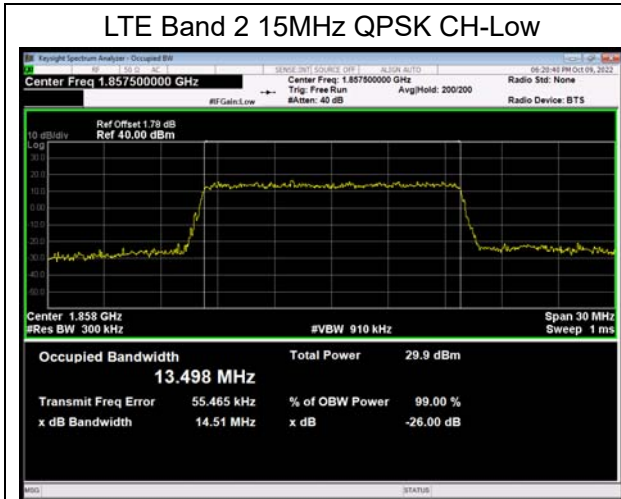

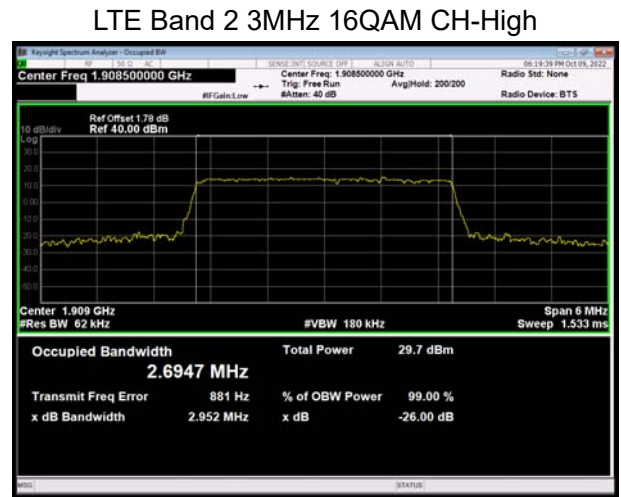
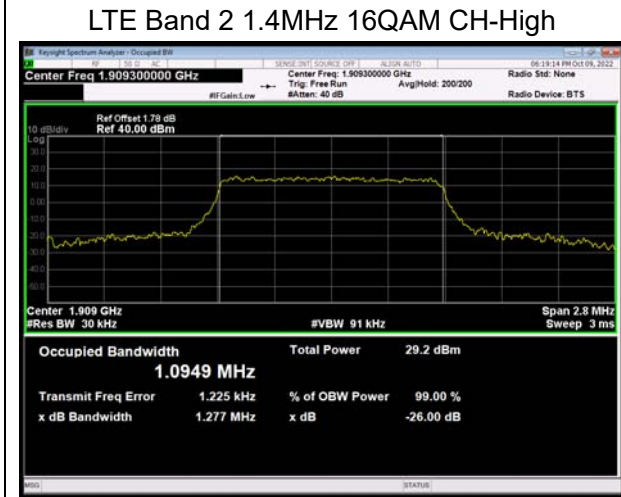
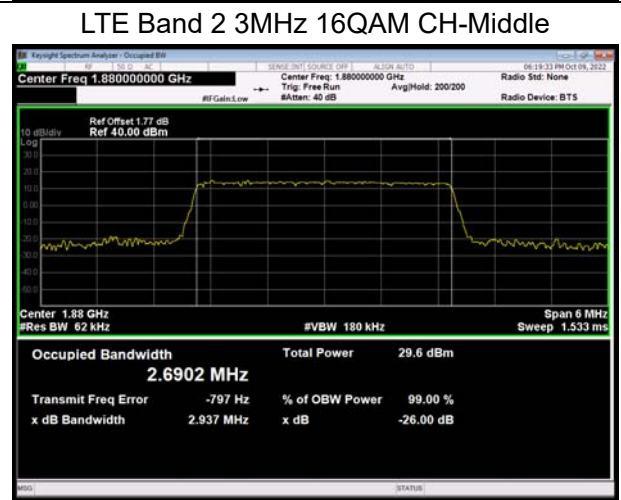
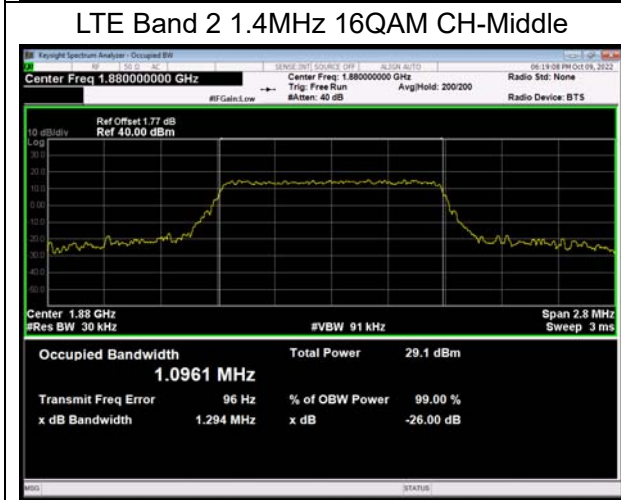
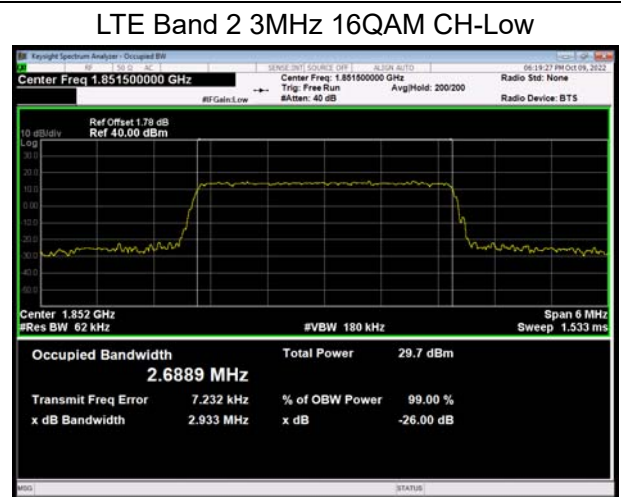
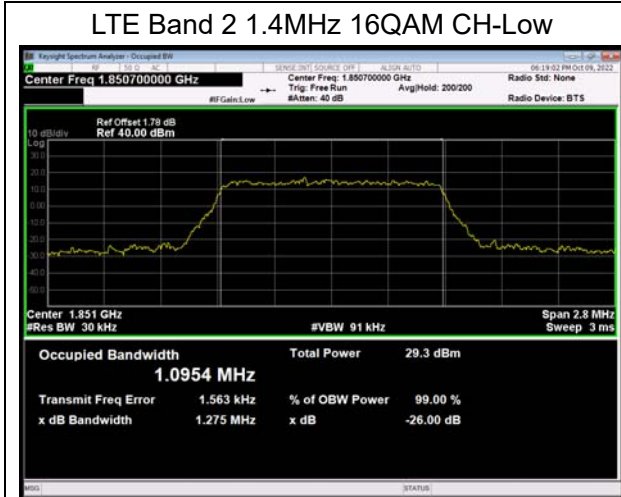

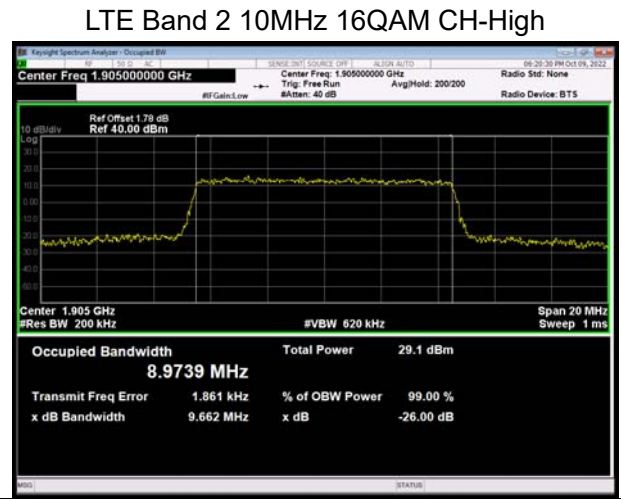
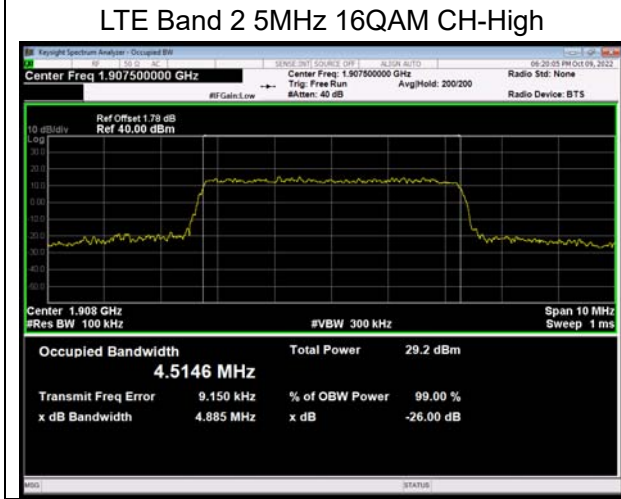
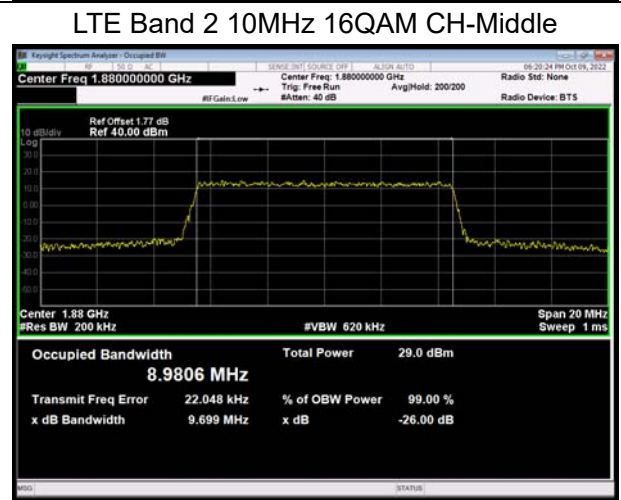
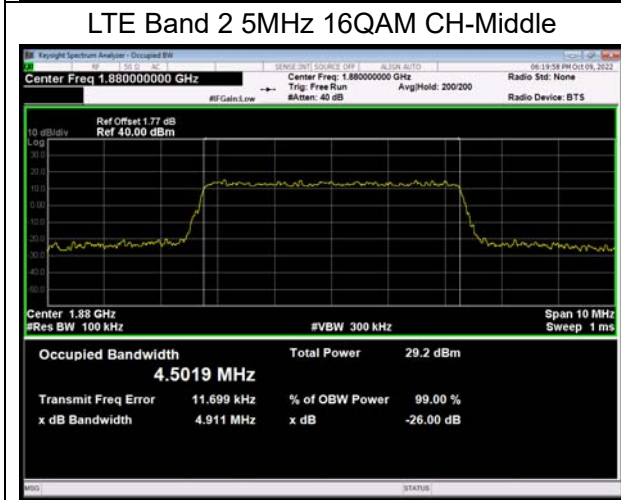
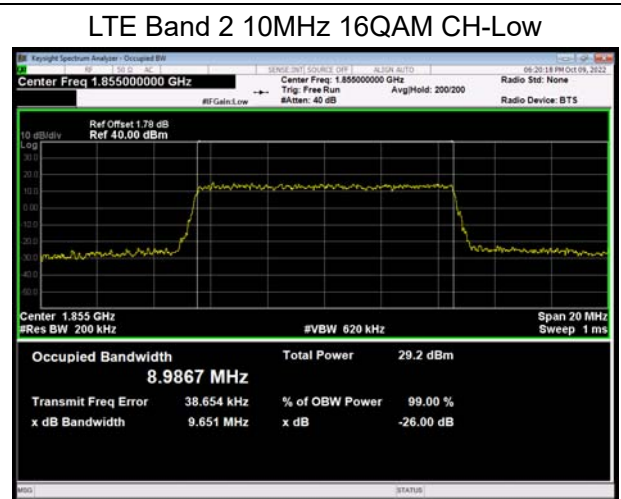
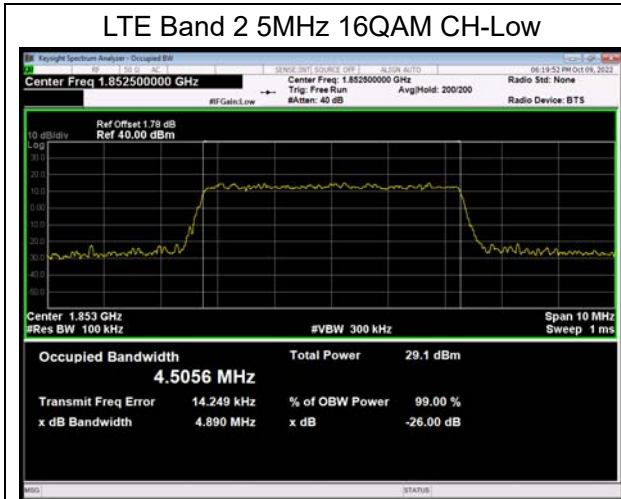



LTE Band 2 15MHz 16QAM CH-Low

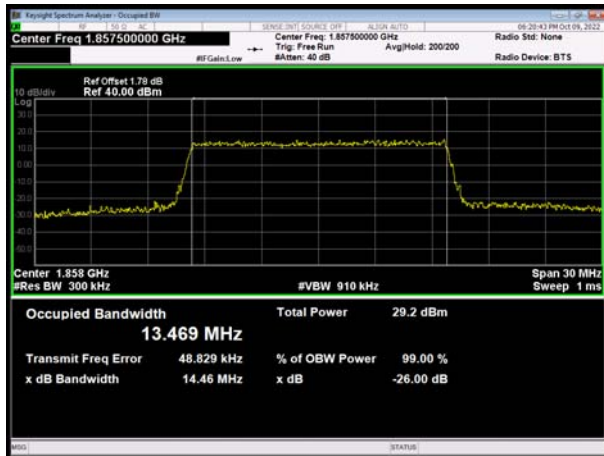

LTE Band 2 20MHz 16QAM CH-Low



LTE Band 2 15MHz 16QAM CH-Middle



LTE Band 2 20MHz 16QAM CH-Middle

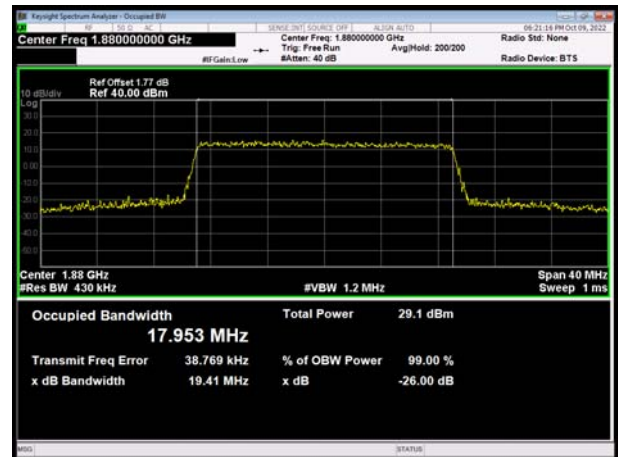

LTE Band 2 15MHz 16QAM CH-High

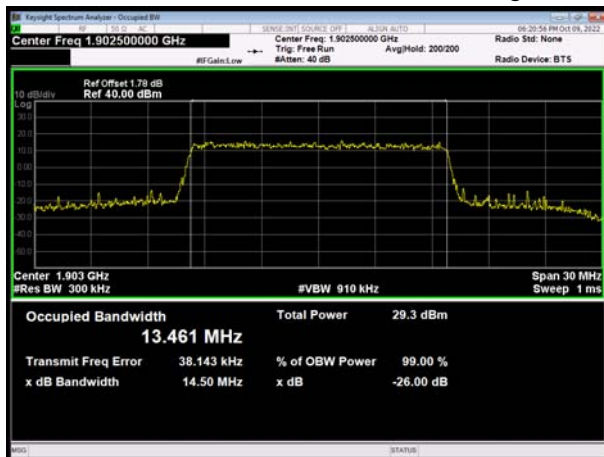

LTE Band 2 20MHz 16QAM CH-High

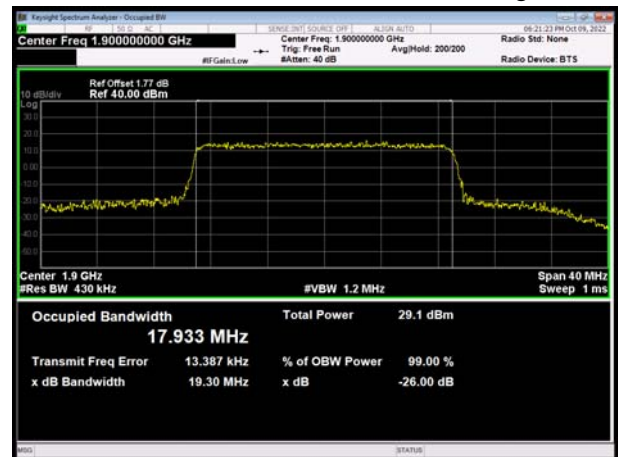



LTE Band 2 1.4MHz 64QAM CH-Low

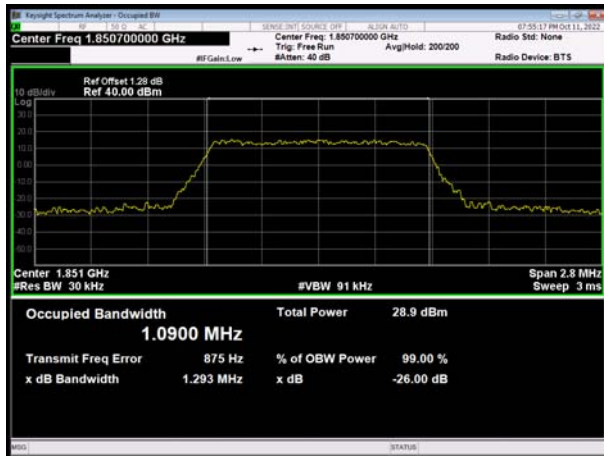

LTE Band 2 3MHz 64QAM CH-Low



LTE Band 2 1.4MHz 64QAM CH-Middle

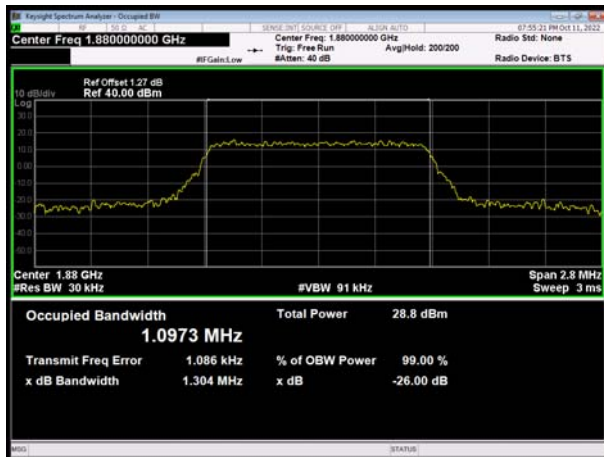

LTE Band 2 3MHz 64QAM CH-Middle

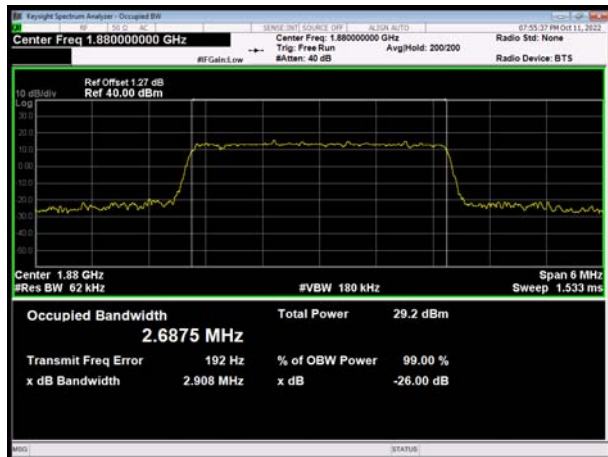

LTE Band 2 1.4MHz 64QAM CH-High

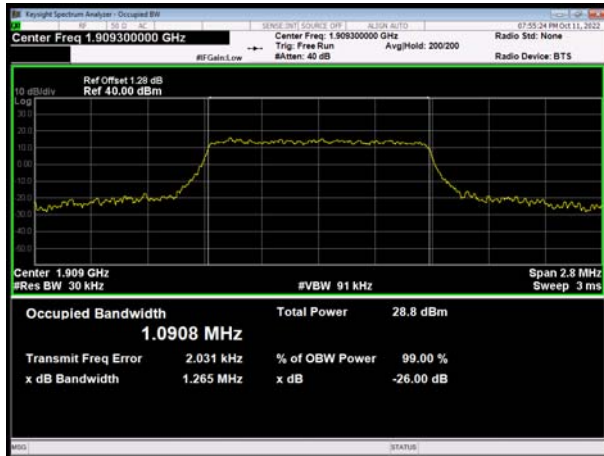

LTE Band 2 3MHz 64QAM CH-High

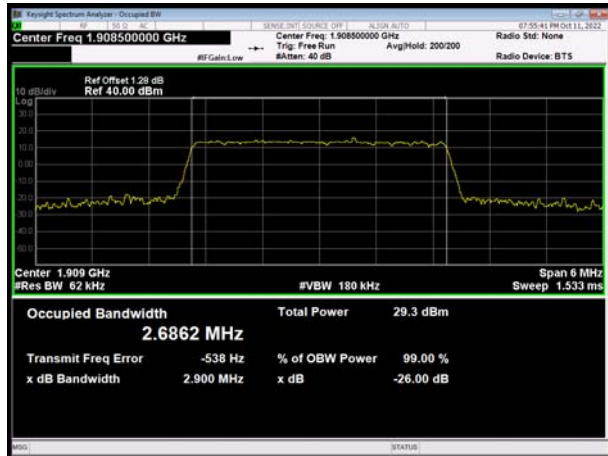

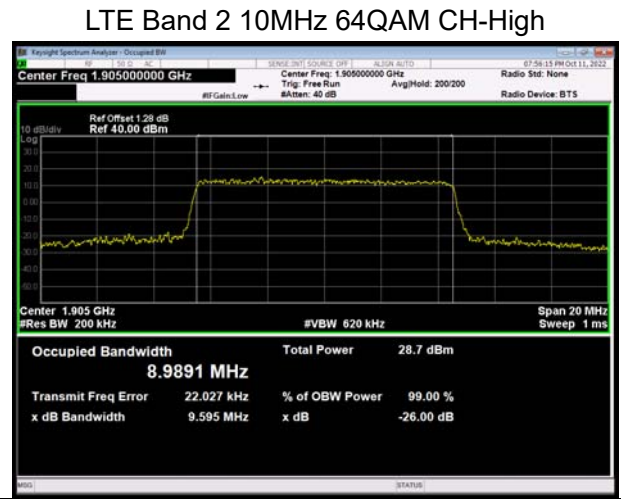
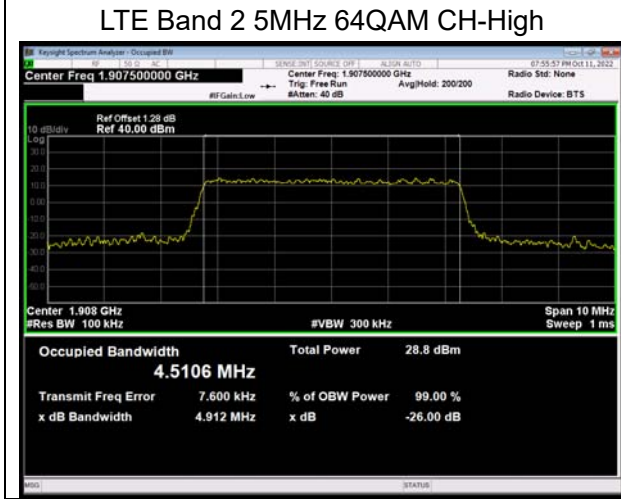
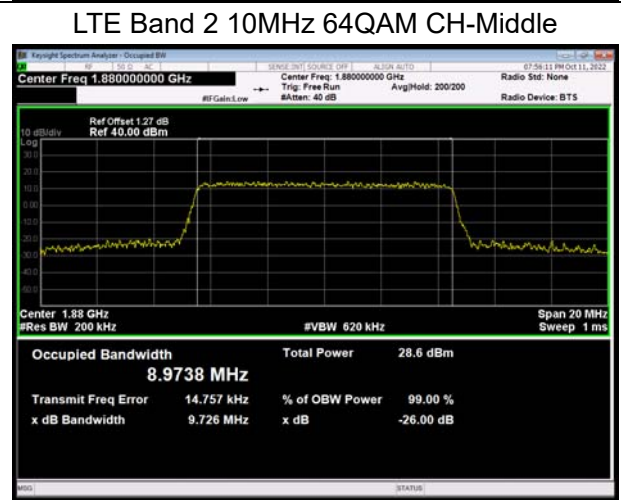
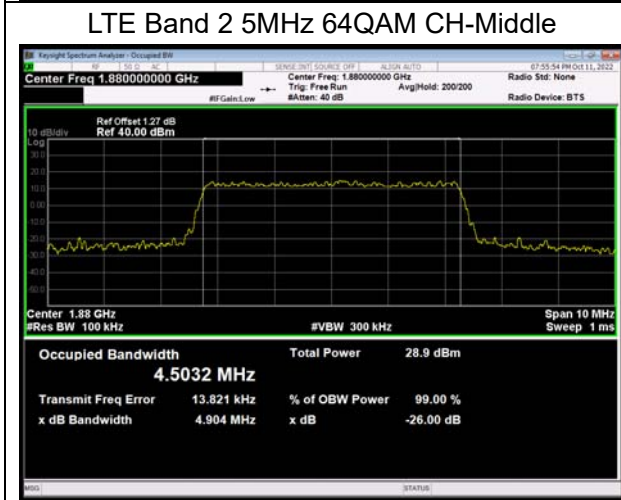
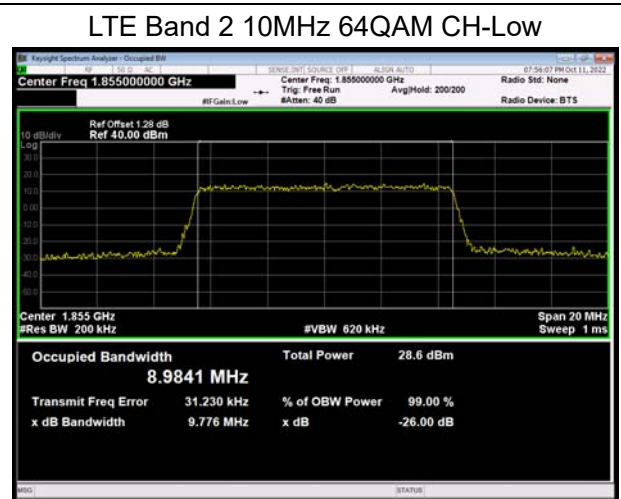
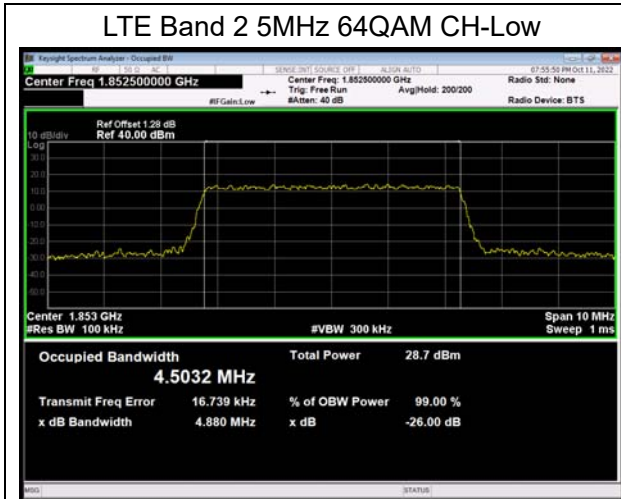

LTE Band 2 15MHz 64QAM CH-Low

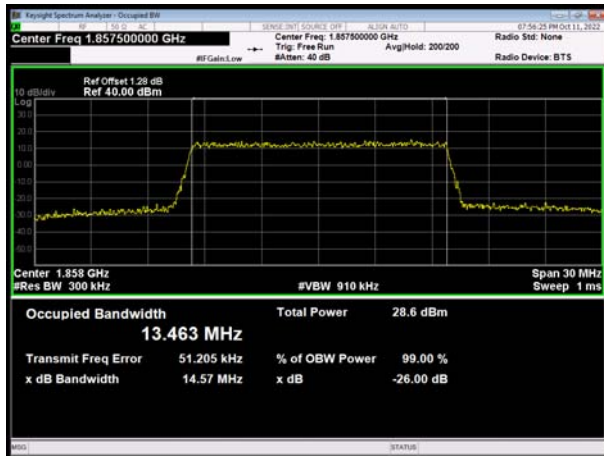

LTE Band 2 20MHz 64QAM CH-Low

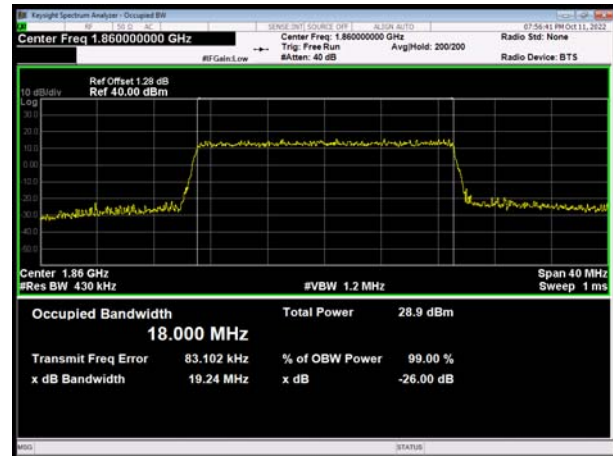

LTE Band 2 15MHz 64QAM CH-Middle

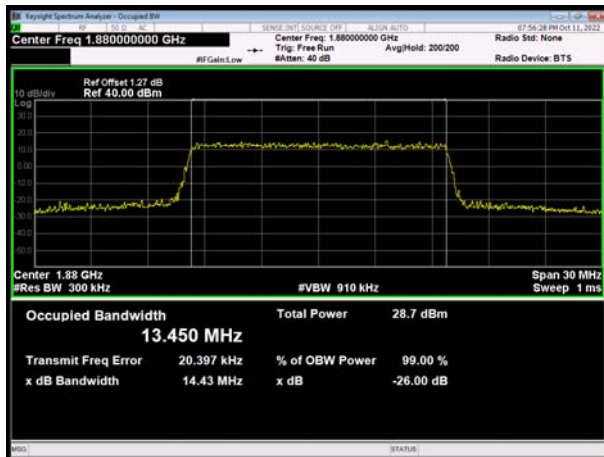

LTE Band 2 20MHz 64QAM CH-Middle



LTE Band 2 15MHz 64QAM CH-High

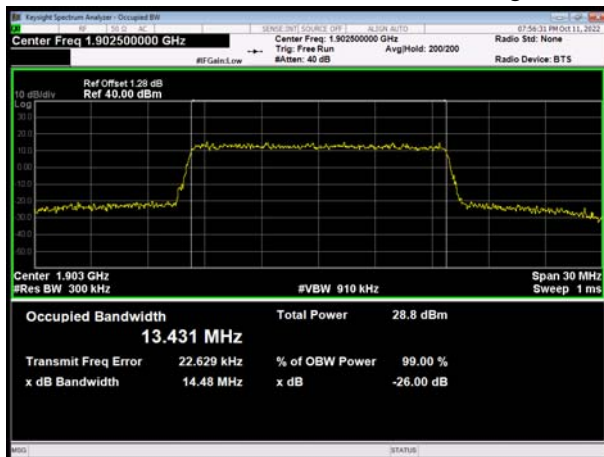

LTE Band 2 20MHz 64QAM CH-High

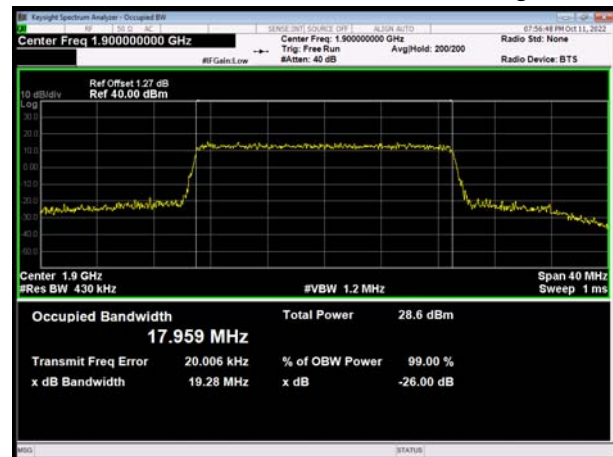

6.3. Band Edge Compliance

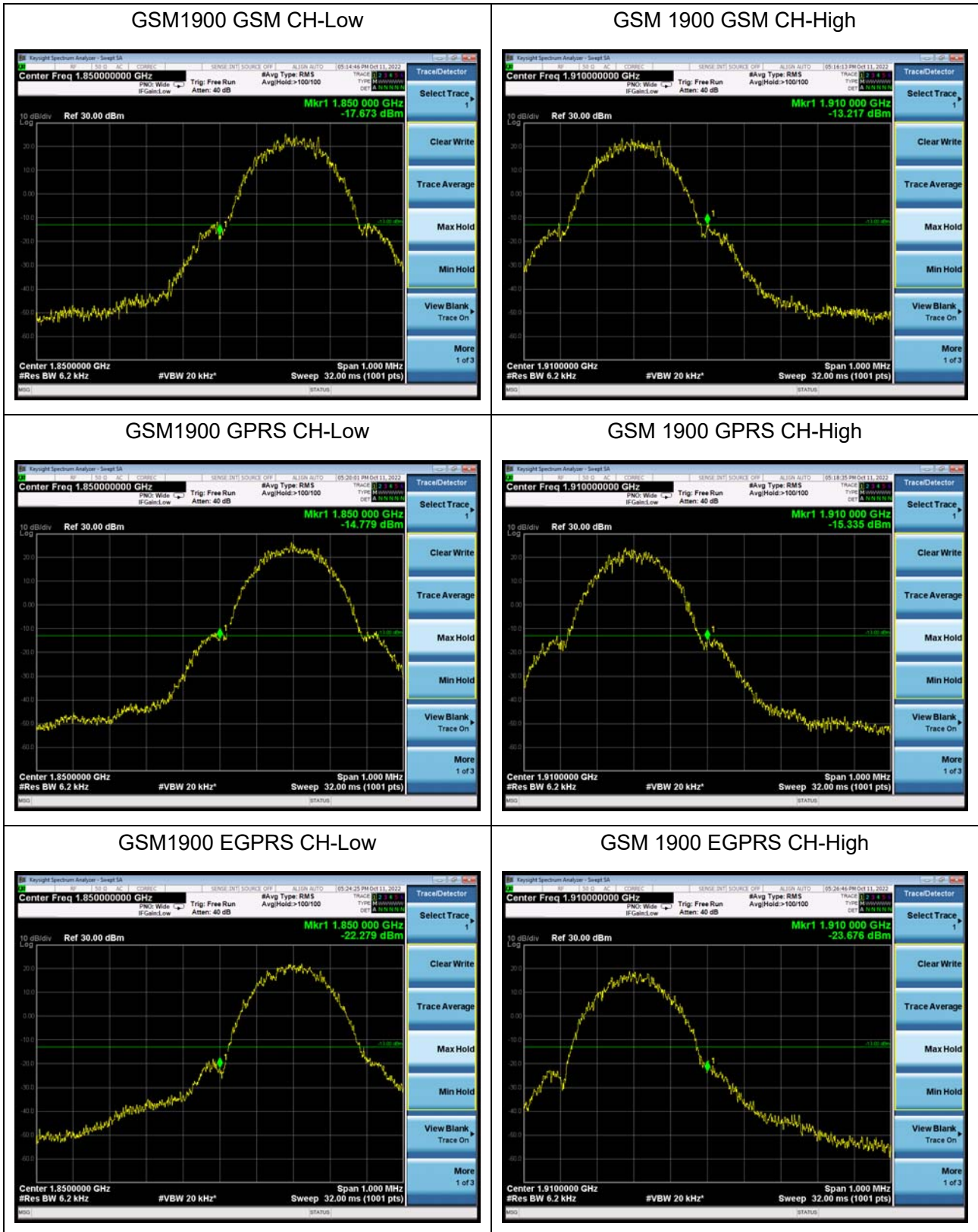



WCDMA Band II RMC CH-Low

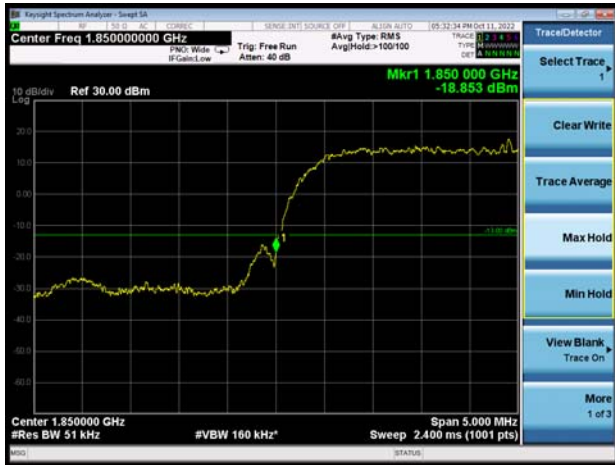

WCDMA Band II RMC CH-High





LTE Band 2 1.4MHz QPSK 1RB CH-Low



LTE Band 2 1.4MHz QPSK 1RB CH-High



LTE Band 2 1.4MHz QPSK 100%RB CH-Low

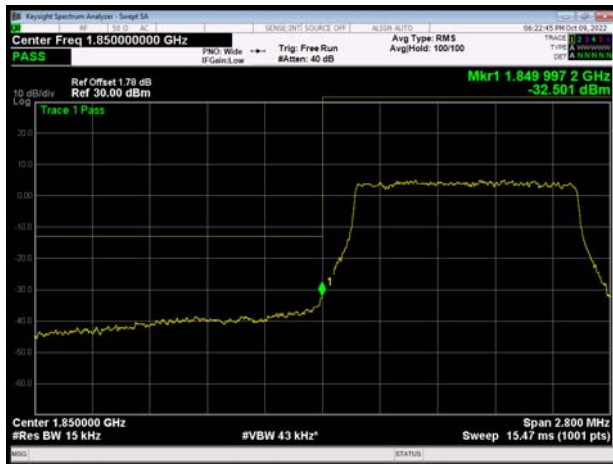

LTE Band 2 1.4MHz QPSK 100%RB CH-High



LTE Band 2 3MHz QPSK 1RB CH-Low

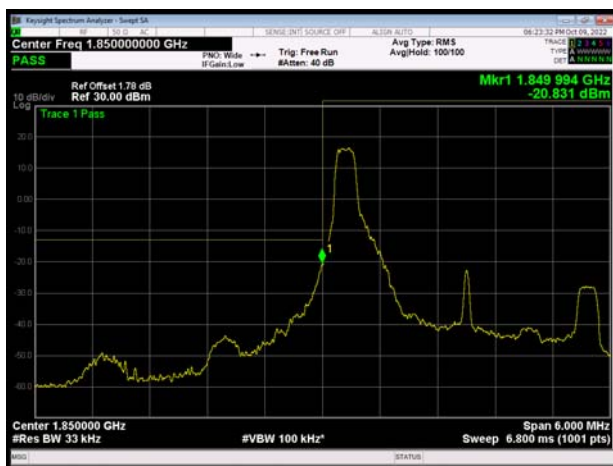

LTE Band 2 3MHz QPSK 1RB CH-High

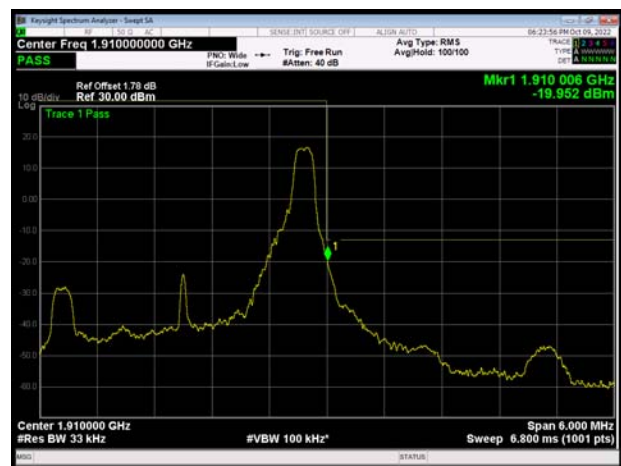



LTE Band 2 3MHz QPSK 100%RB CH-Low

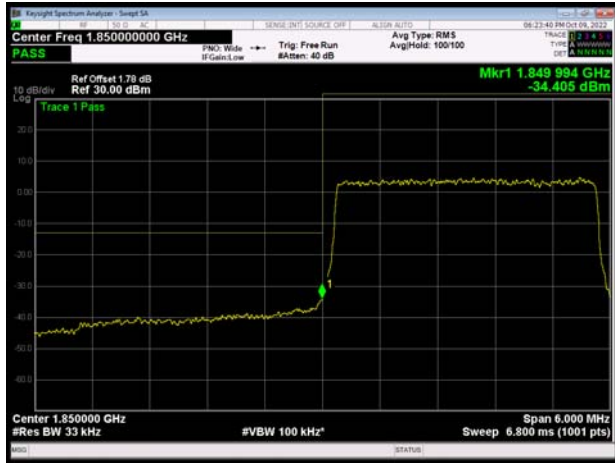

LTE Band 2 3MHz QPSK 100%RB CH-High

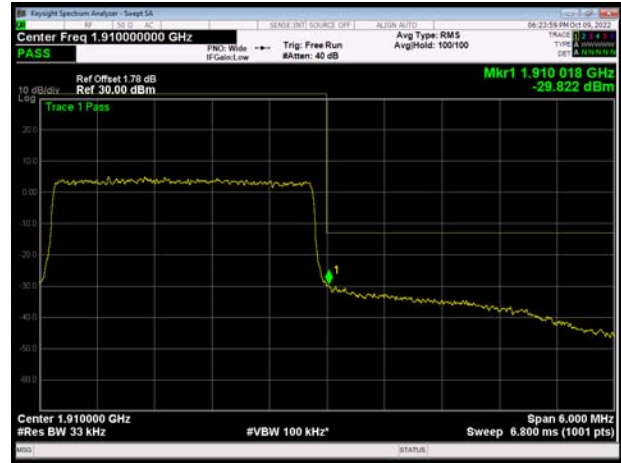

LTE Band 2 5MHz QPSK 1RB CH-Low



LTE Band 2 5MHz QPSK 1RB CH-High

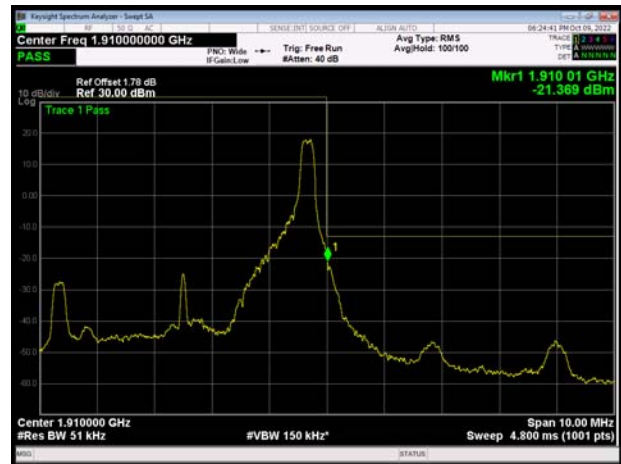

LTE Band 2 5MHz QPSK 100%RB CH-Low

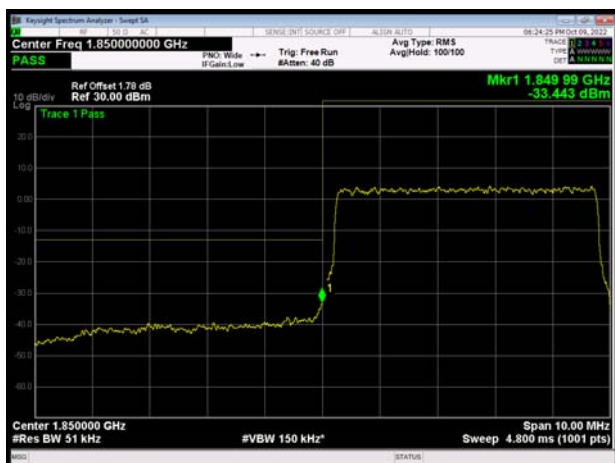

LTE Band 2 5MHz QPSK 100%RB CH-High

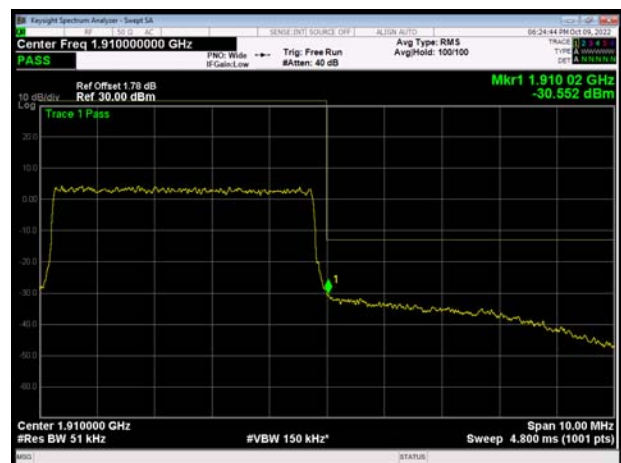



LTE Band 2 10MHz QPSK 1RB CH-Low

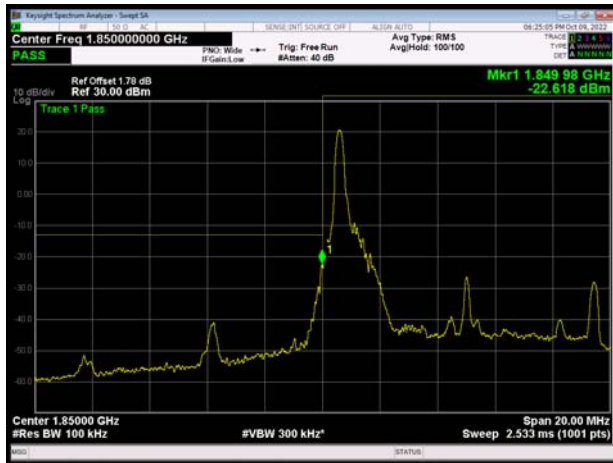

LTE Band 2 10MHz QPSK 1RB CH-High

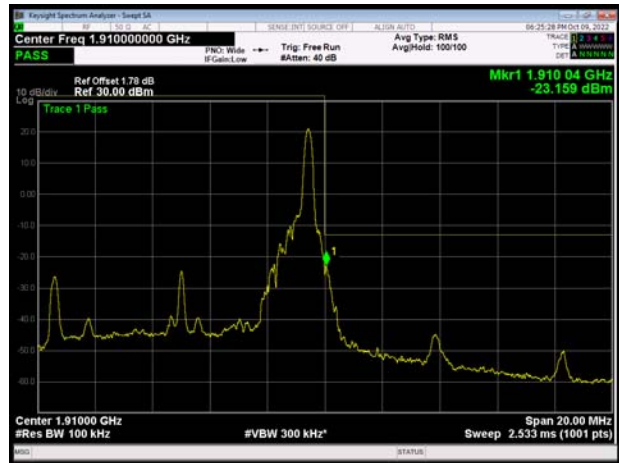

LTE Band 2 10MHz QPSK 100%RB CH-Low

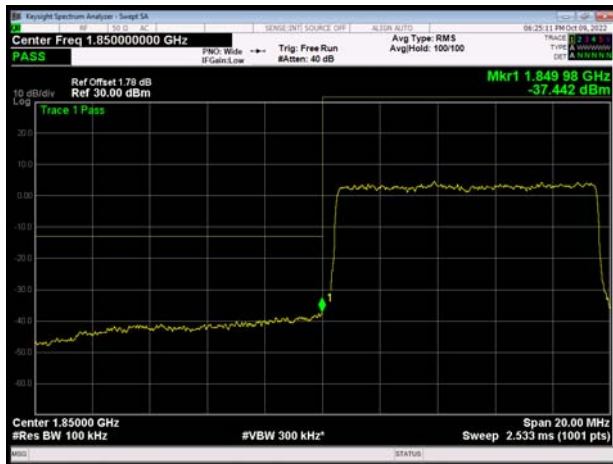

LTE Band 2 10MHz QPSK 100%RB CH-High



LTE Band 2 15MHz QPSK 1RB CH-Low

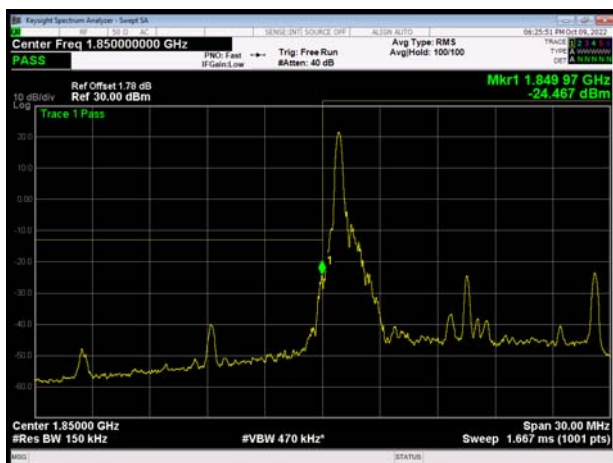

LTE Band 2 15MHz QPSK 1RB CH-High

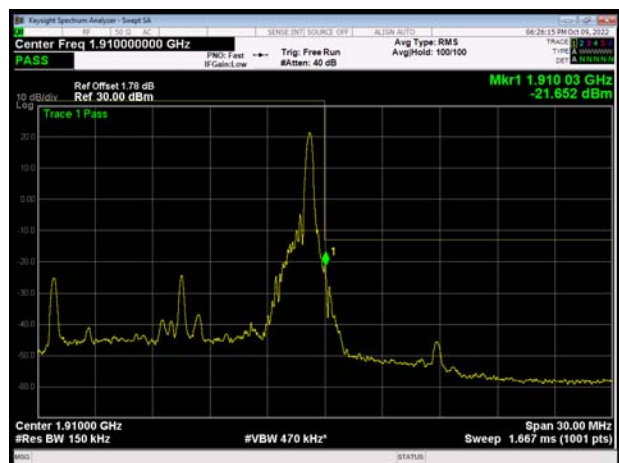



LTE Band 2 15MHz QPSK 100%RB CH-Low



LTE Band 2 15MHz QPSK 100%RB CH-High



LTE Band 2 20MHz QPSK 1RB CH-Low

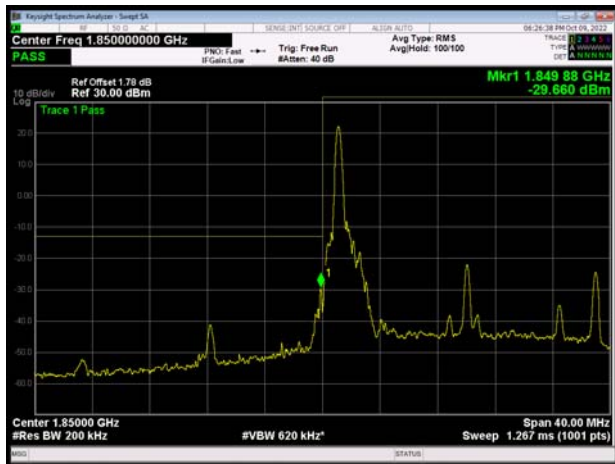

LTE Band 2 20MHz QPSK 1RB CH-High

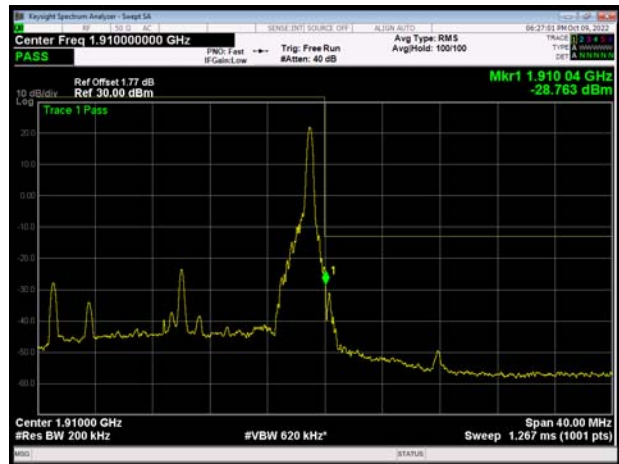

LTE Band 2 20MHz QPSK 100%RB CH-Low

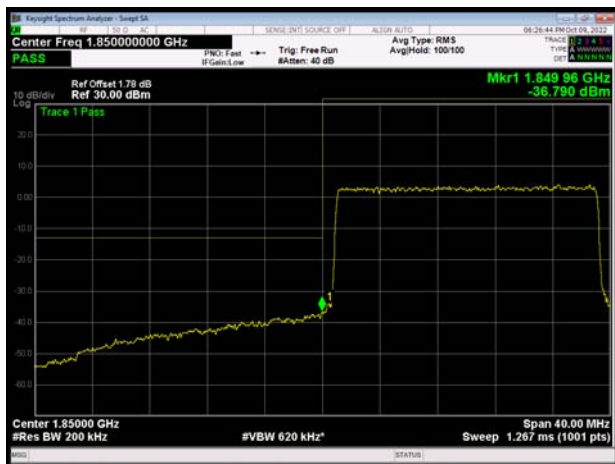

LTE Band 2 20MHz QPSK 100%RB CH-High





LTE Band 2 1.4MHz 16QAM 1RB CH-Low

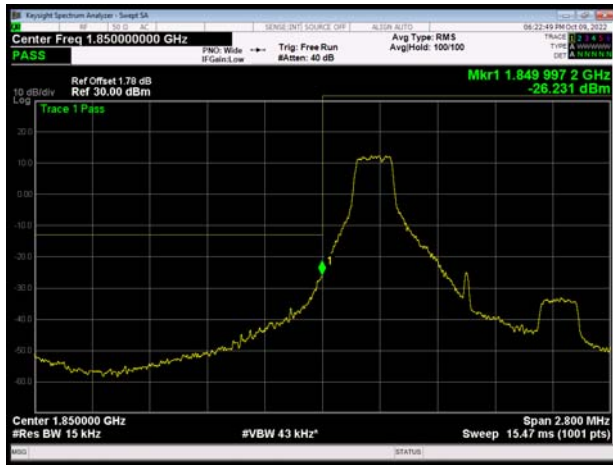

LTE Band 2 1.4MHz 16QAM 1RB CH-High



LTE Band 2 1.4MHz 16QAM 100%RB CH-Low



LTE Band 2 1.4MHz 16QAM 100%RB CH-High



LTE Band 2 3MHz 16QAM 1RB CH-Low

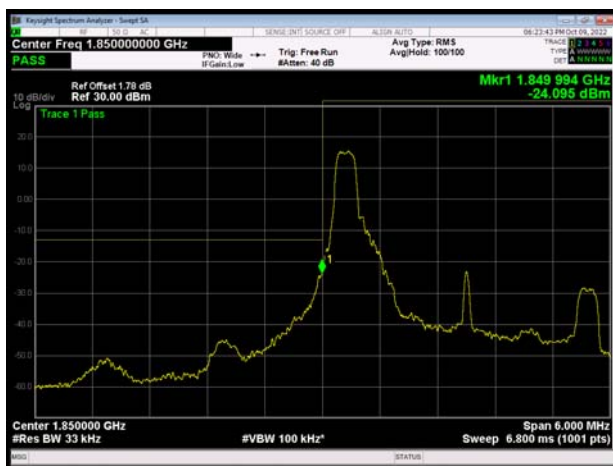

LTE Band 2 3MHz 16QAM 1RB CH-High

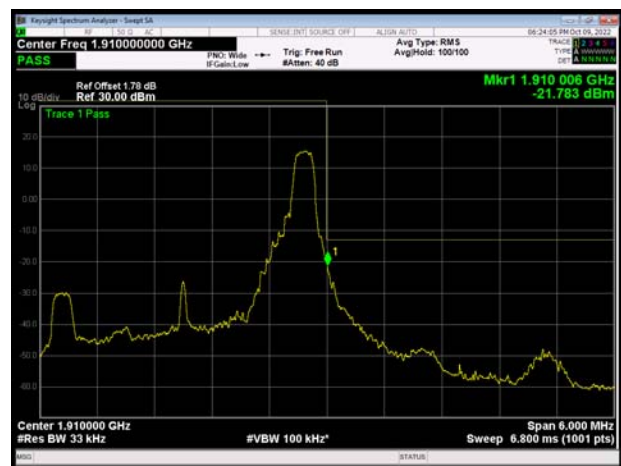



LTE Band 2 3MHz 16QAM 100%RB CH-Low

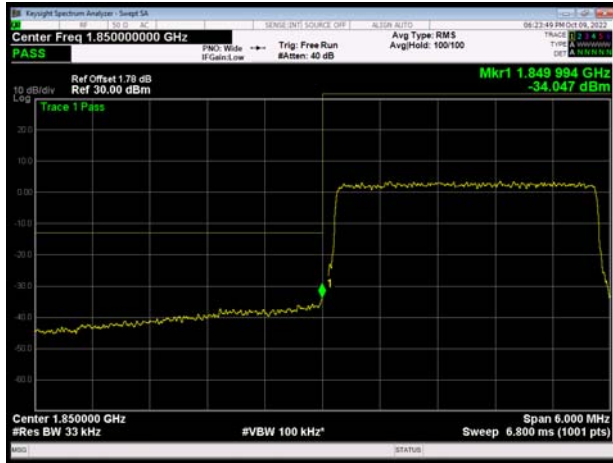

LTE Band 2 3MHz 16QAM 100%RB CH-High

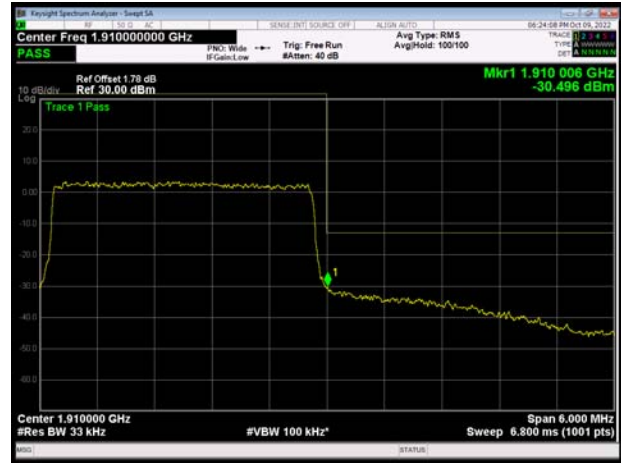

LTE Band 2 5MHz 16QAM 1RB CH-Low

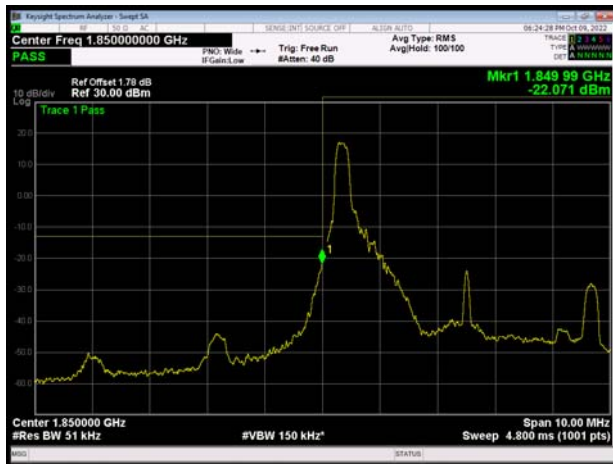

LTE Band 2 5MHz 16QAM 1RB CH-High

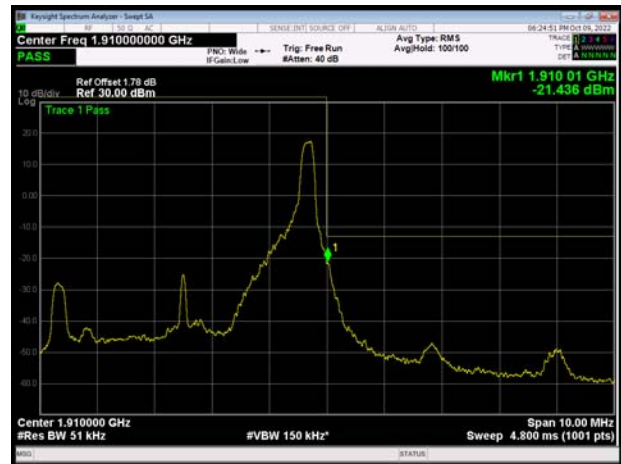

LTE Band 2 5MHz 16QAM 100%RB CH-Low

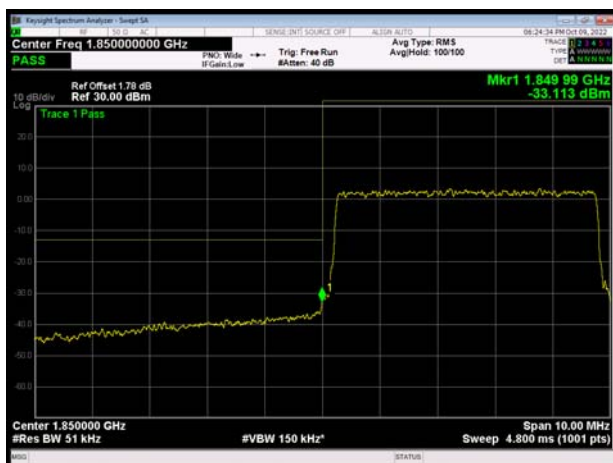

LTE Band 2 5MHz 16QAM 100%RB CH-High

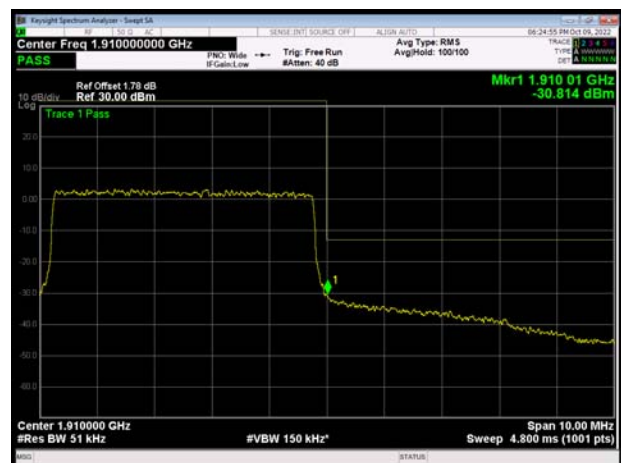

LTE Band 2 10MHz 16QAM 1RB CH-Low

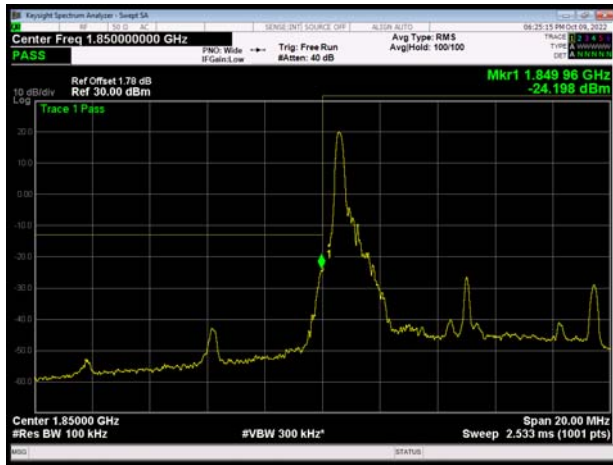

LTE Band 2 10MHz 16QAM 1RB CH-High

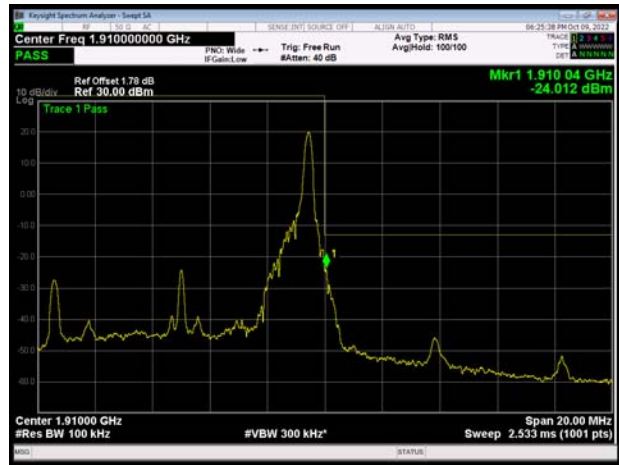

LTE Band 2 10MHz 16QAM 100%RB CH-Low

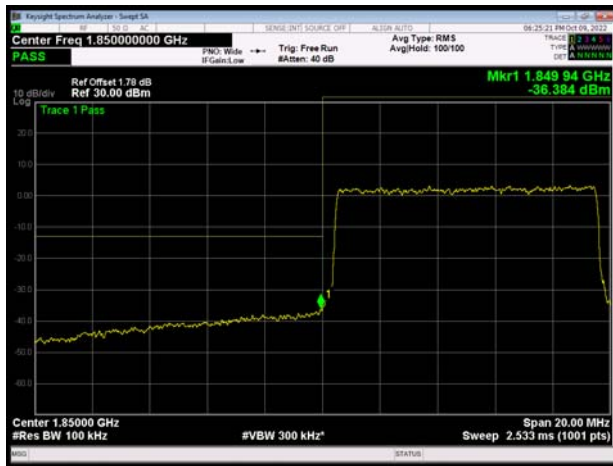

LTE Band 2 10MHz 16QAM 100%RB CH-High

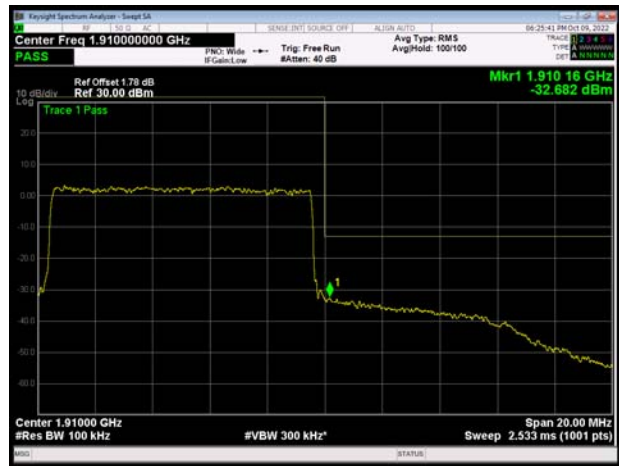

LTE Band 2 15MHz 16QAM 1RB CH-Low

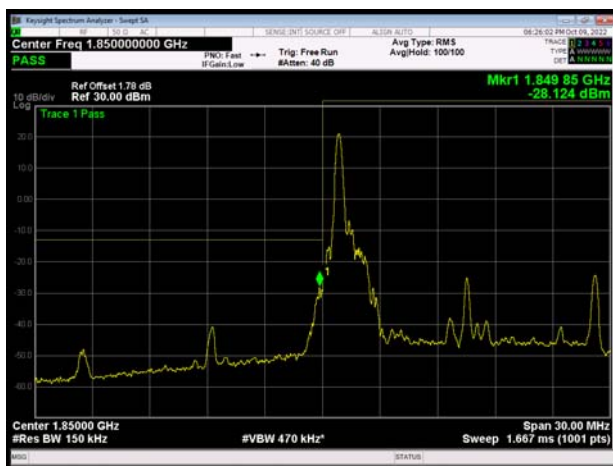

LTE Band 2 15MHz 16QAM 1RB CH-High

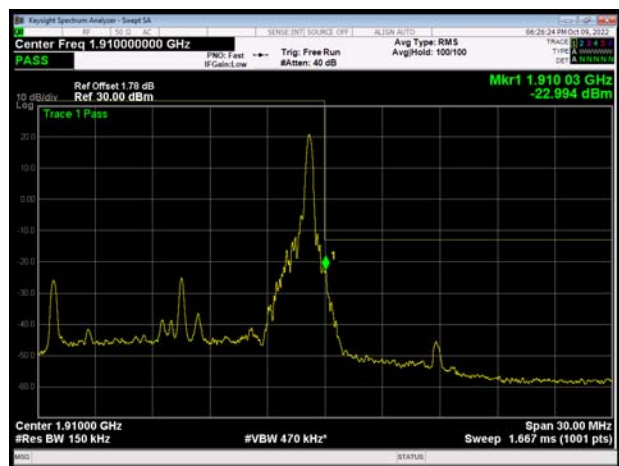



LTE Band 2 15MHz 16QAM 100%RB CH-Low

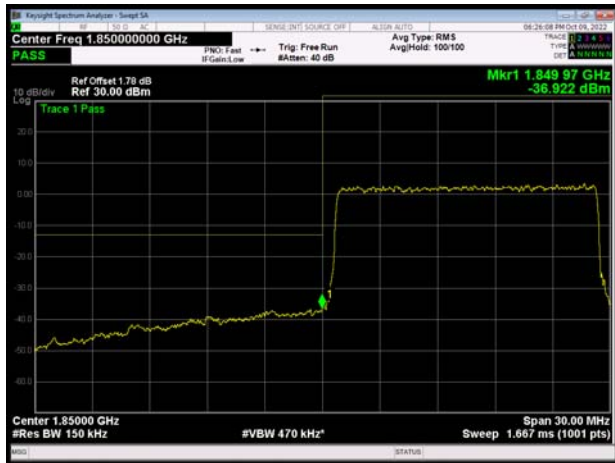

LTE Band 2 15MHz 16QAM 100%RB CH-High



LTE Band 2 20MHz 16QAM 1RB CH-Low



LTE Band 2 20MHz 16QAM 1RB CH-High

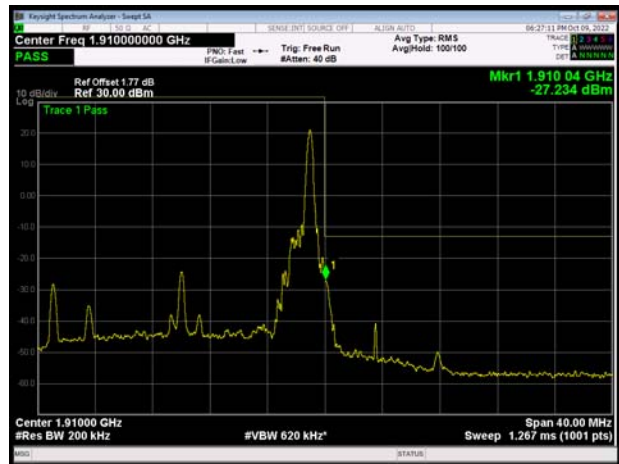

LTE Band 2 20MHz 16QAM 100%RB CH-Low

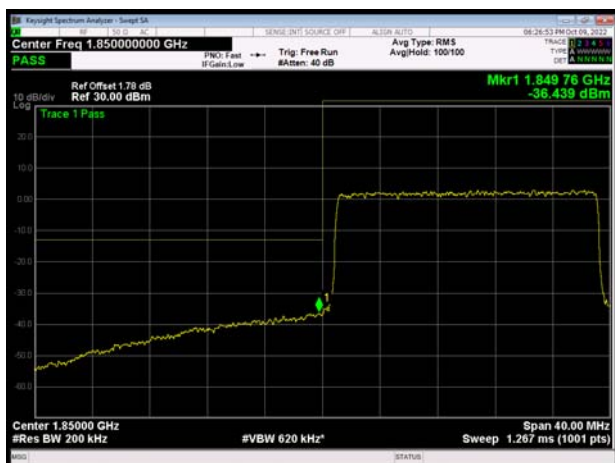

LTE Band 2 20MHz 16QAM 100%RB CH-High

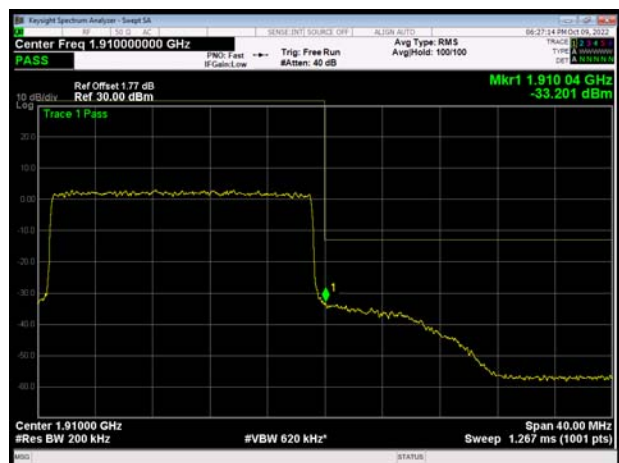

LTE Band 2 1.4MHz 64QAM 1RB CH-Low

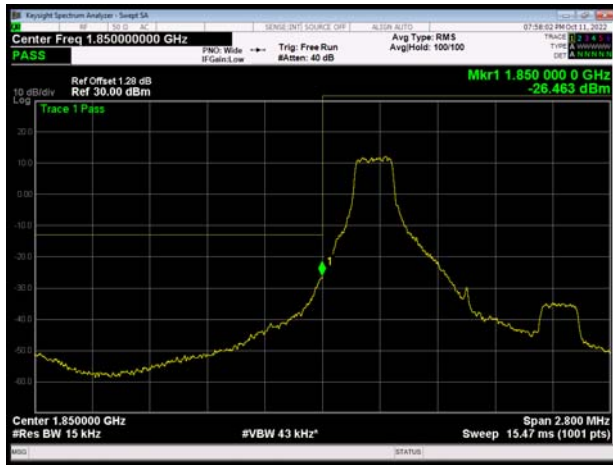

LTE Band 2 1.4MHz 64QAM 1RB CH-High



LTE Band 2 1.4MHz 64QAM 100%RB CH-Low



LTE Band 2 1.4MHz 64QAM 100%RB CH-High



LTE Band 2 3MHz 64QAM 1RB CH-Low



LTE Band 2 3MHz 64QAM 1RB CH-High

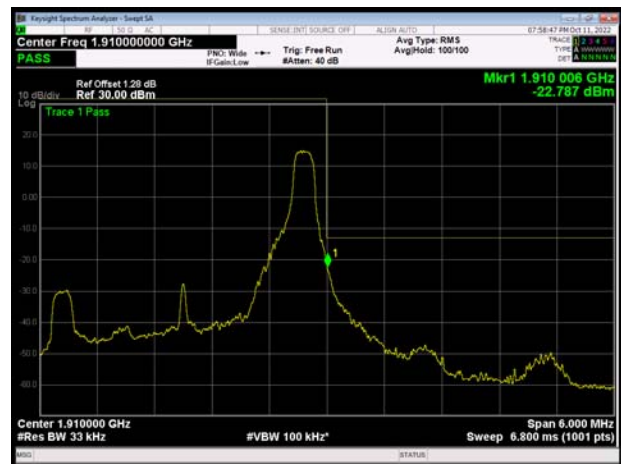



LTE Band 2 3MHz 64QAM 100%RB CH-Low



LTE Band 2 3MHz 64QAM 100%RB CH-High

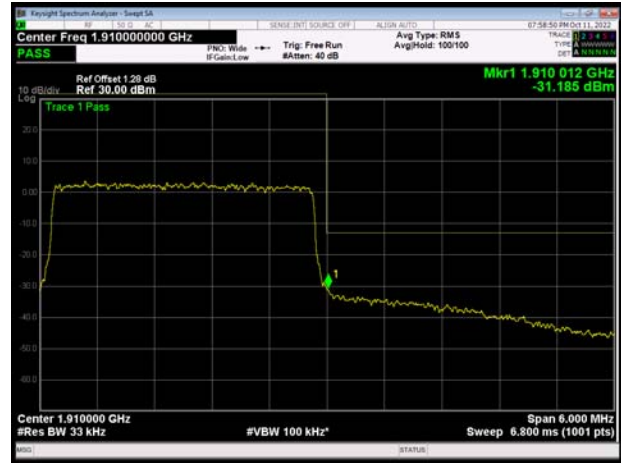

LTE Band 2 5MHz 64QAM 1RB CH-Low

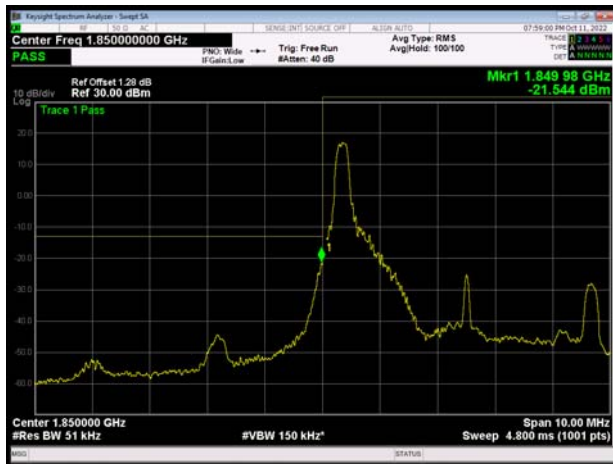

LTE Band 2 5MHz 64QAM 1RB CH-High

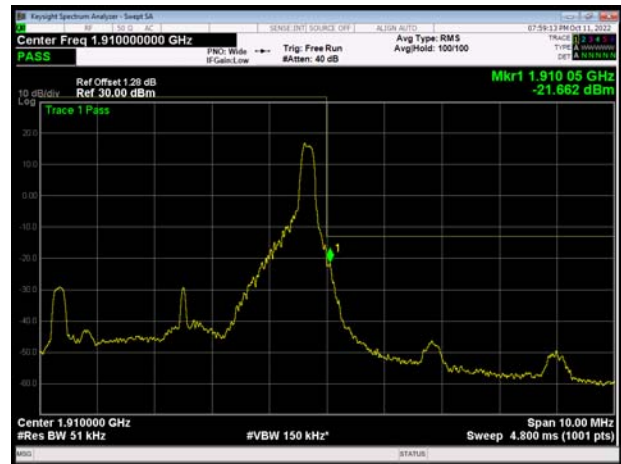

LTE Band 2 5MHz 64QAM 100%RB CH-Low

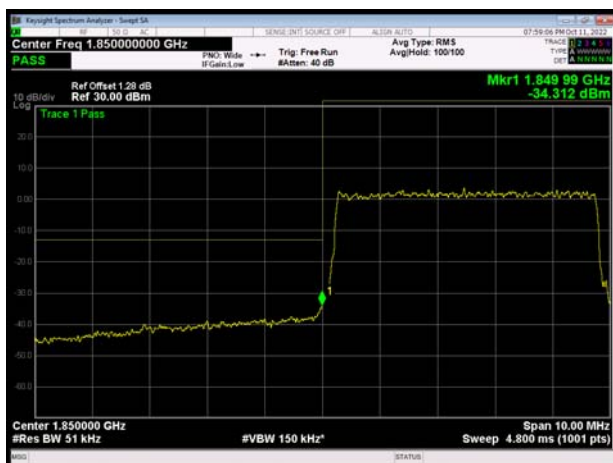

LTE Band 2 5MHz 64QAM 100%RB CH-High

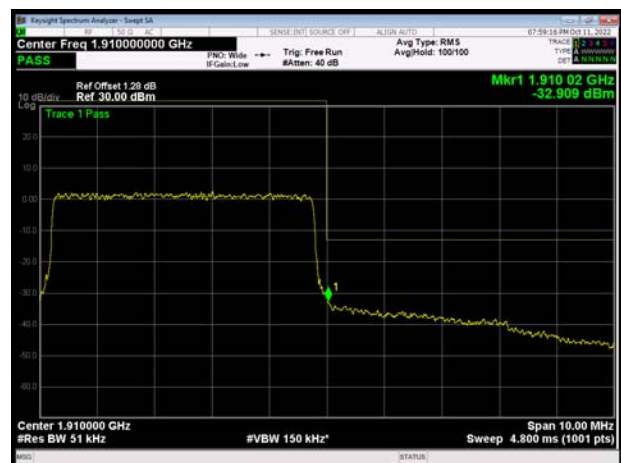



LTE Band 2 10MHz 64QAM 1RB CH-Low

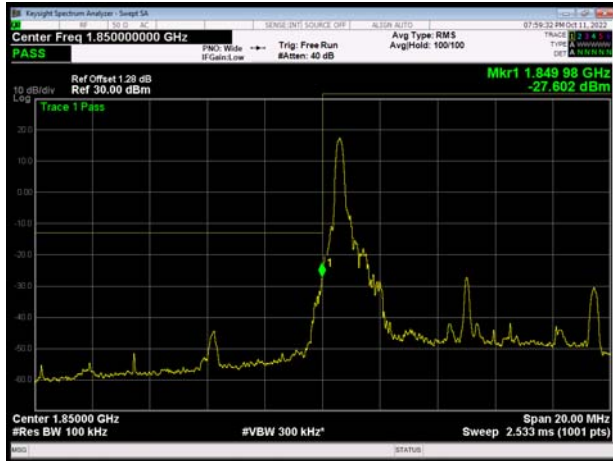

LTE Band 2 10MHz 64QAM 1RB CH-High

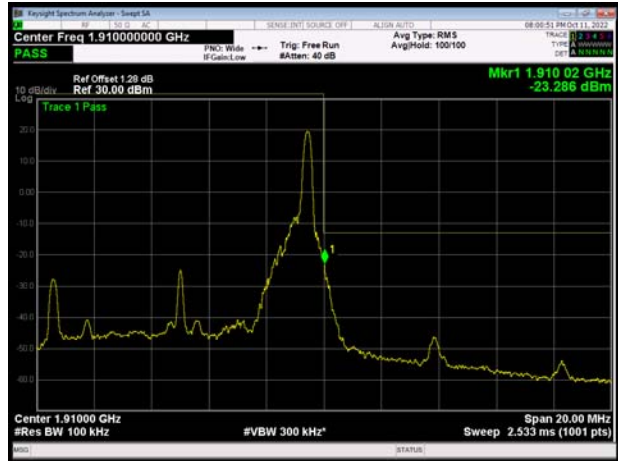

LTE Band 2 10MHz 64QAM 100%RB CH-Low

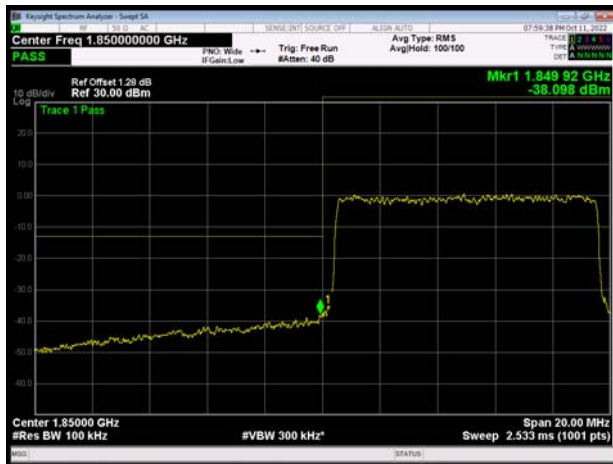

LTE Band 2 10MHz 64QAM 100%RB CH-High

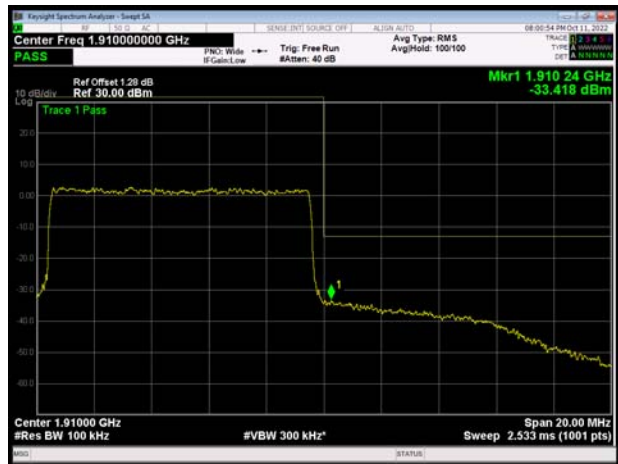

LTE Band 2 15MHz 64QAM 1RB CH-Low



LTE Band 2 15MHz 64QAM 1RB CH-High





LTE Band 2 15MHz 64QAM 100%RB CH-Low

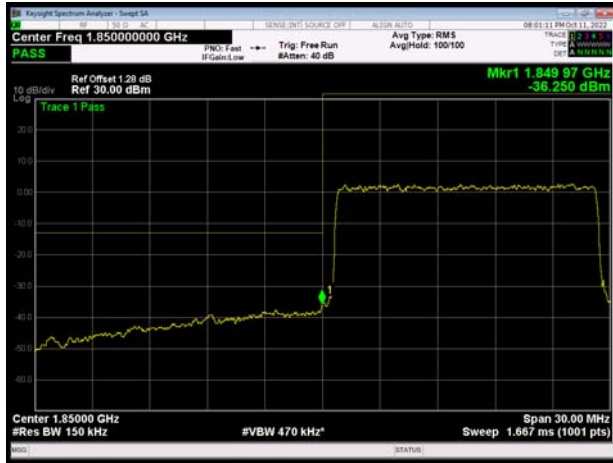

LTE Band 2 15MHz 64QAM 100%RB CH-High



LTE Band 2 20MHz 64QAM 1RB CH-Low

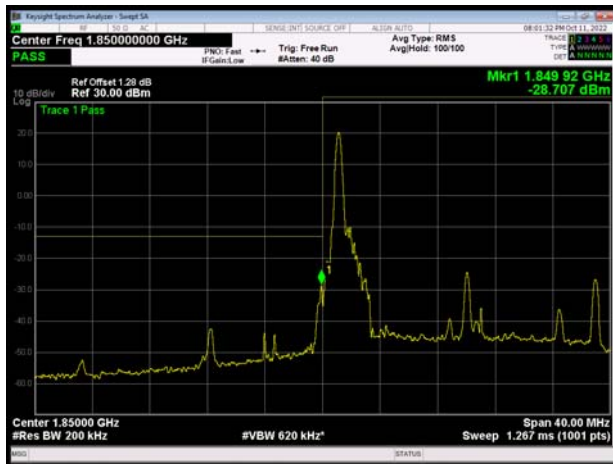

LTE Band 2 20MHz 64QAM 1RB CH-High

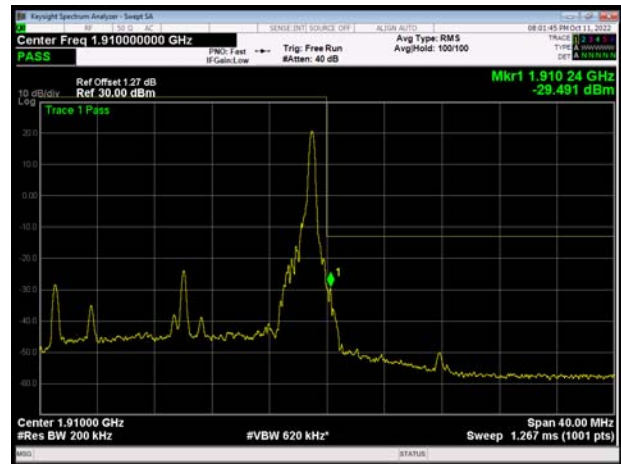

LTE Band 2 20MHz 64QAM 100%RB CH-Low

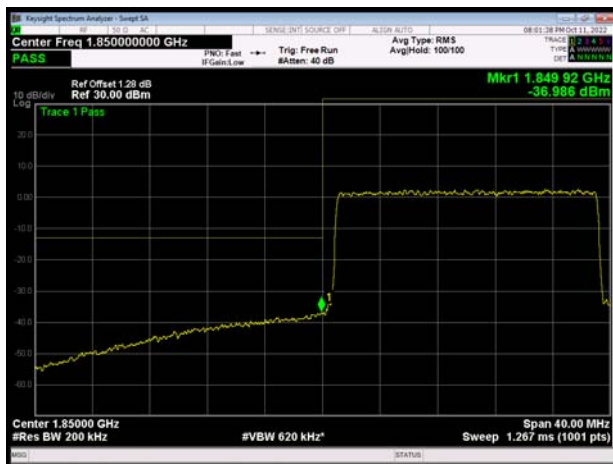

LTE Band 2 20MHz 64QAM 100%RB CH-High



6.4. Peak-to-Average Power Ratio (PAPR)

Mode	Channel	Frequency (MHz)	Peak(dBm)	Avg(dBm)	PAPR(dB)	Limit(dB)	Conclusion
GSM 1900 (GMSK)	512	1850.2	29.59	26.96	2.63	≤13	PASS
	661	1880	29.39	26.78	2.61	≤13	PASS
	810	1909.8	29.21	26.59	2.62	≤13	PASS
GPRS 1900 (GMSK)	512	1850.2	29.61	26.99	2.62	≤13	PASS
	661	1880	29.37	26.76	2.61	≤13	PASS
	810	1909.8	29.22	26.60	2.62	≤13	PASS
EGPRS 1900 (8PSK)	512	1850.2	28.47	22.92	5.55	≤13	PASS
	661	1880	28.34	22.83	5.51	≤13	PASS
	810	1909.8	28.18	22.65	5.53	≤13	PASS
WCDMA Band II (RMC)	9262	1852.4	26.05	23.05	3.00	≤13	PASS
	9400	1880	25.62	22.82	2.80	≤13	PASS
	9538	1907.6	25.45	22.77	2.68	≤13	PASS

LTE Band 2								
Modulation	Bandwidth (MHz)	Channel	Frequency (MHz)	Peak (dBm)	Avg (dBm)	PAPR (dB)	Limit (dB)	Conclusion
QPSK	1.4	18607	1850.7	27.36	22.11	5.25	≤13	PASS
		18900	1880.0	26.79	22.12	4.67	≤13	PASS
		19193	1909.3	26.73	22.18	4.55	≤13	PASS
	3	18615	1851.5	27.39	22.11	5.28	≤13	PASS
		18900	1880	26.80	22.07	4.73	≤13	PASS
		19185	1908.5	26.78	22.12	4.66	≤13	PASS
	5	18625	1852.5	27.52	22.11	5.41	≤13	PASS
		18900	1880	26.98	22.12	4.86	≤13	PASS
		19175	1907.5	26.85	22.12	4.73	≤13	PASS
	10	18650	1855	27.51	22.15	5.36	≤13	PASS
		18900	1880	27.07	22.16	4.91	≤13	PASS
		19150	1905	26.91	22.16	4.75	≤13	PASS
	15	18675	1857.5	27.79	22.15	5.64	≤13	PASS
		18900	1880	27.44	22.15	5.29	≤13	PASS
		19125	1902.5	27.32	22.19	5.13	≤13	PASS
	20	18700	1860	27.40	22.01	5.39	≤13	PASS
		18900	1880	27.31	22.05	5.26	≤13	PASS
		19100	1900	27.27	22.07	5.20	≤13	PASS
16QAM	1.4	18607	1850.7	27.22	21.20	6.02	≤13	PASS



		18900	1880.0	26.68	21.18	5.50	≤13	PASS	
		19193	1909.3	26.61	21.21	5.40	≤13	PASS	
	3	18615	1851.5	27.32	21.18	6.14	≤13	PASS	
		18900	1880	26.70	21.11	5.59	≤13	PASS	
		19185	1908.5	26.72	21.20	5.52	≤13	PASS	
	5	18625	1852.5	27.30	21.19	6.11	≤13	PASS	
		18900	1880	26.86	21.18	5.68	≤13	PASS	
		19175	1907.5	26.72	21.22	5.50	≤13	PASS	
	10	18650	1855	27.35	21.22	6.13	≤13	PASS	
		18900	1880	26.91	21.21	5.70	≤13	PASS	
		19150	1905	26.76	21.21	5.55	≤13	PASS	
	15	18675	1857.5	27.41	21.17	6.24	≤13	PASS	
		18900	1880	27.05	21.15	5.90	≤13	PASS	
		19125	1902.5	26.94	21.20	5.74	≤13	PASS	
	20	18700	1860	27.34	21.19	6.15	≤13	PASS	
		18900	1880	27.10	21.11	5.99	≤13	PASS	
		19100	1900	27.03	21.13	5.90	≤13	PASS	
	64QAM	1.4	18607	1850.7	26.83	20.77	6.06	≤13	PASS
			18900	1880.0	26.28	20.75	5.53	≤13	PASS
			19193	1909.3	26.38	20.85	5.53	≤13	PASS
		3	18615	1851.5	26.90	20.76	6.14	≤13	PASS
			18900	1880	26.40	20.72	5.68	≤13	PASS
			19185	1908.5	26.31	20.32	5.99	≤13	PASS
		5	18625	1852.5	26.82	18.52	8.30	≤13	PASS
18900			1880	26.28	17.67	8.61	≤13	PASS	
19175			1907.5	26.30	19.14	7.16	≤13	PASS	
10		18650	1855	27.03	20.81	6.22	≤13	PASS	
		18900	1880	26.57	20.77	5.80	≤13	PASS	
		19150	1905	26.40	20.73	5.67	≤13	PASS	
15		18675	1857.5	27.13	20.79	6.34	≤13	PASS	
		18900	1880	26.68	20.72	5.96	≤13	PASS	
		19125	1902.5	26.63	20.78	5.85	≤13	PASS	
20		18700	1860	27.02	20.76	6.26	≤13	PASS	
		18900	1880	26.73	20.66	6.07	≤13	PASS	
		19100	1900	26.70	20.72	5.98	≤13	PASS	

6.5. Frequency Stability

	Condition		Freq.Error (Hz)	Freq.Error (Hz)	Frequency Stability (ppm)	Frequency Stability (ppm)	Verdict
	Temperature	Voltage	GMSK	8PSK	GMSK	8PSK	
GSM1900	Normal (25°C)	Normal	9.57	9.18	0.00509	0.00488	PASS
	Extreme (50°C)		12.86	1.98	0.00684	0.00105	PASS
	Extreme (40°C)		9.98	1.89	0.00531	0.00101	PASS
	Extreme (30°C)		10.40	5.38	0.00553	0.00286	PASS
	Extreme (20°C)		17.93	11.37	0.00953	0.00605	PASS
	Extreme (10°C)		10.55	3.73	0.00561	0.00199	PASS
	Extreme (0°C)		10.56	14.38	0.00562	0.00765	PASS
	Extreme (-10°C)		3.70	8.15	0.00197	0.00434	PASS
	Extreme (-20°C)		2.99	13.92	0.00159	0.00741	PASS
	Extreme (-30°C)		13.80	14.69	0.00734	0.00781	PASS
	25°C		LV	10.80	11.84	0.00574	0.00630
		HV	5.29	15.63	0.00281	0.00831	PASS

	Condition		Freq.Error (Hz)	Freq.Error (Hz)	Frequency Stability (ppm)	Frequency Stability (ppm)	Verdict
	Temperature	Voltage	BPSK	QPSK	BPSK	QPSK	
WCDMA Band II	Normal (25°C)	Normal	5.97	14.58	0.00318	0.00776	PASS
	Extreme (50°C)		12.14	8.92	0.00645	0.00475	PASS
	Extreme (40°C)		1.72	17.18	0.00092	0.00914	PASS
	Extreme (30°C)		5.39	7.31	0.00287	0.00389	PASS
	Extreme (20°C)		8.52	10.11	0.00453	0.00538	PASS
	Extreme (10°C)		2.17	13.27	0.00115	0.00706	PASS
	Extreme (0°C)		9.42	14.40	0.00501	0.00766	PASS
	Extreme (-10°C)		8.12	10.77	0.00432	0.00573	PASS
	Extreme (-20°C)		16.40	4.23	0.00872	0.00225	PASS
	Extreme (-30°C)		5.65	9.27	0.00300	0.00493	PASS
	25°C		LV	13.18	10.25	0.00701	0.00545
		HV	16.40	17.54	0.00872	0.00933	PASS



LTE Band 2								
Condition		Freq.Error	Freq.Error	Freq.Error	Frequency	Frequency	Frequency	Verdict
BANDWIDTH	1.4MHz	(Hz)	(Hz)	(Hz)	Stability	Stability	Stability	
Temperature	Voltage	64QAM	16QAM	QPSK	(ppm)	(ppm)	(ppm)	
Normal (25°C)	Normal	10.56	1.51	12.07	0.00562	0.00080	0.00642	PASS
Extreme (50°C)		8.73	13.64	2.86	0.00465	0.00725	0.00152	PASS
Extreme (40°C)		1.39	4.12	15.03	0.00074	0.00219	0.00800	PASS
Extreme (30°C)		5.15	4.60	12.72	0.00274	0.00245	0.00676	PASS
Extreme (20°C)		14.71	4.17	1.48	0.00782	0.00222	0.00079	PASS
Extreme (10°C)		1.14	9.04	1.67	0.00060	0.00481	0.00089	PASS
Extreme (0°C)		16.61	17.78	16.84	0.00884	0.00946	0.00896	PASS
Extreme (-10°C)		13.15	8.44	13.11	0.00700	0.00449	0.00697	PASS
Extreme (-20°C)		14.51	17.19	9.30	0.00772	0.00914	0.00495	PASS
Extreme (-30°C)		10.25	1.55	4.63	0.00545	0.00082	0.00246	PASS
25°C	LV	12.87	13.73	12.39	0.00684	0.00730	0.00659	PASS
	HV	8.33	10.34	9.20	0.00443	0.00550	0.00490	PASS
Condition		Freq.Error	Freq.Error	Freq.Error	Frequency	Frequency	Frequency	Verdict
BANDWIDTH	3MHz	(Hz)	(Hz)	(Hz)	Stability	Stability	Stability	
Temperature	Voltage	64QAM	16QAM	QPSK	(ppm)	(ppm)	(ppm)	
Normal (25°C)	Normal	6.44	4.06	3.22	0.00343	0.00216	0.00171	PASS
Extreme (50°C)		6.60	1.34	2.28	0.00351	0.00071	0.00121	PASS
Extreme (40°C)		13.76	10.42	14.91	0.00732	0.00554	0.00793	PASS
Extreme (30°C)		14.40	8.42	13.09	0.00766	0.00448	0.00696	PASS
Extreme (20°C)		3.04	1.26	9.19	0.00162	0.00067	0.00489	PASS
Extreme (10°C)		11.29	17.98	11.06	0.00601	0.00956	0.00588	PASS
Extreme (0°C)		1.83	4.49	16.90	0.00097	0.00239	0.00899	PASS
Extreme (-10°C)		2.55	13.45	13.46	0.00136	0.00715	0.00716	PASS
Extreme (-20°C)		3.80	17.05	12.11	0.00202	0.00907	0.00644	PASS
Extreme (-30°C)		11.30	9.40	13.17	0.00601	0.00500	0.00701	PASS
25°C	LV	8.80	3.11	13.75	0.00468	0.00165	0.00732	PASS
	HV	15.20	12.83	5.83	0.00809	0.00682	0.00310	PASS
Condition		Freq.Error	Freq.Error	Freq.Error	Frequency	Frequency	Frequency	Verdict
BANDWIDTH	5MHz	(Hz)	(Hz)	(Hz)	Stability	Stability	Stability	
Temperature	Voltage	64QAM	16QAM	QPSK	(ppm)	(ppm)	(ppm)	
Normal (25°C)	Normal	8.10	2.27	7.47	0.00431	0.00121	0.00397	PASS
Extreme (50°C)		1.70	6.43	17.94	0.00091	0.00342	0.00954	PASS



Extreme (40°C)		9.64	4.40	1.39	0.00513	0.00234	0.00074	PASS
Extreme (30°C)		10.16	2.55	9.57	0.00541	0.00135	0.00509	PASS
Extreme (20°C)		15.78	3.09	4.12	0.00839	0.00164	0.00219	PASS
Extreme (10°C)		5.70	17.30	11.82	0.00303	0.00920	0.00629	PASS
Extreme (0°C)		6.28	16.23	1.22	0.00334	0.00863	0.00065	PASS
Extreme (-10°C)		14.77	11.57	10.83	0.00786	0.00615	0.00576	PASS
Extreme (-20°C)		7.58	6.80	11.53	0.00403	0.00362	0.00613	PASS
Extreme (-30°C)		3.82	11.76	9.59	0.00203	0.00626	0.00510	PASS
25°C	LV	4.49	8.51	5.53	0.00239	0.00453	0.00294	PASS
	HV	16.22	9.17	11.69	0.00863	0.00488	0.00622	PASS
Condition		Freq.Error	Freq.Error	Freq.Error	Frequency	Frequency	Frequency	Verdict
BANDWIDTH	10MHz	(Hz)	(Hz)	(Hz)	Stability (ppm)	Stability (ppm)	Stability (ppm)	
Temperature	Voltage	64QAM	16QAM	QPSK	64QAM	16QAM	QPSK	
Normal (25°C)	Normal	8.77	8.50	16.73	0.00467	0.00452	0.00890	PASS
Extreme (50°C)		16.24	7.45	8.13	0.00864	0.00396	0.00432	PASS
Extreme (40°C)		2.24	17.28	16.13	0.00119	0.00919	0.00858	PASS
Extreme (30°C)		13.58	14.40	2.09	0.00722	0.00766	0.00111	PASS
Extreme (20°C)		1.20	8.72	2.30	0.00064	0.00464	0.00122	PASS
Extreme (10°C)		4.12	6.54	4.71	0.00219	0.00348	0.00250	PASS
Extreme (0°C)		10.28	2.81	14.97	0.00547	0.00150	0.00796	PASS
Extreme (-10°C)		14.51	4.26	3.46	0.00772	0.00227	0.00184	PASS
Extreme (-20°C)		14.41	2.77	6.51	0.00767	0.00147	0.00346	PASS
Extreme (-30°C)		5.03	5.49	6.05	0.00267	0.00292	0.00322	PASS
25°C	LV	14.01	15.27	2.46	0.00745	0.00812	0.00131	PASS
	HV	15.20	2.08	11.01	0.00808	0.00111	0.00585	PASS
Condition		Freq.Error	Freq.Error	Freq.Error	Frequency	Frequency	Frequency	Verdict
BANDWIDTH	15MHz	(Hz)	(Hz)	(Hz)	Stability (ppm)	Stability (ppm)	Stability (ppm)	
Temperature	Voltage	64QAM	16QAM	QPSK	64QAM	16QAM	QPSK	
Normal (25°C)	Normal	16.68	2.30	10.66	0.00887	0.00123	0.00567	PASS
Extreme (50°C)		7.24	13.01	8.58	0.00385	0.00692	0.00457	PASS
Extreme (40°C)		4.57	2.00	10.06	0.00243	0.00106	0.00535	PASS
Extreme (30°C)		9.07	13.41	6.81	0.00482	0.00713	0.00362	PASS
Extreme (20°C)		5.48	1.97	13.83	0.00292	0.00105	0.00736	PASS
Extreme (10°C)		5.15	9.73	7.65	0.00274	0.00518	0.00407	PASS
Extreme (0°C)		3.81	8.77	4.06	0.00203	0.00466	0.00216	PASS
Extreme (-10°C)		9.05	3.69	17.55	0.00482	0.00196	0.00933	PASS
Extreme (-20°C)		15.98	7.95	7.97	0.00850	0.00423	0.00424	PASS
Extreme (-30°C)		9.94	15.30	16.35	0.00529	0.00814	0.00870	PASS
25°C	LV	1.60	13.34	1.81	0.00085	0.00710	0.00096	PASS



	HV	8.61	10.63	14.75	0.00458	0.00566	0.00784	PASS
Condition		Freq.Error	Freq.Error	Freq.Error	Frequency	Frequency	Frequency	Verdict
BANDWIDTH	20MHz	(Hz)	(Hz)	(Hz)	Stability	Stability	Stability	
Temperature	Voltage	64QAM	16QAM	QPSK	64QAM	16QAM	QPSK	
Normal (25°C)	Normal	8.75	17.88	17.85	0.00465	0.00951	0.00949	PASS
Extreme (50°C)		7.14	10.47	12.23	0.00380	0.00557	0.00651	PASS
Extreme (40°C)		14.77	12.82	1.58	0.00785	0.00682	0.00084	PASS
Extreme (30°C)		3.70	9.23	15.75	0.00197	0.00491	0.00838	PASS
Extreme (20°C)		17.82	1.94	13.94	0.00948	0.00103	0.00742	PASS
Extreme (10°C)		4.09	12.82	9.00	0.00218	0.00682	0.00479	PASS
Extreme (0°C)		12.11	9.18	2.93	0.00644	0.00488	0.00156	PASS
Extreme (-10°C)		3.58	9.57	6.13	0.00190	0.00509	0.00326	PASS
Extreme (-20°C)		11.11	7.22	2.60	0.00591	0.00384	0.00138	PASS
Extreme (-30°C)		9.10	7.07	14.63	0.00484	0.00376	0.00778	PASS
25°C	LV	4.11	2.98	11.39	0.00219	0.00159	0.00606	PASS
	HV	15.20	16.17	1.46	0.00809	0.00860	0.00078	PASS

6.6. Spurious Emissions at Antenna Terminals

Sweep the whole frequency band through the range from 9kHz to the 10th harmonic of the carrier, the emissions more than 20 dB below the limit are not reported. The signal beyond the limit is carrier.

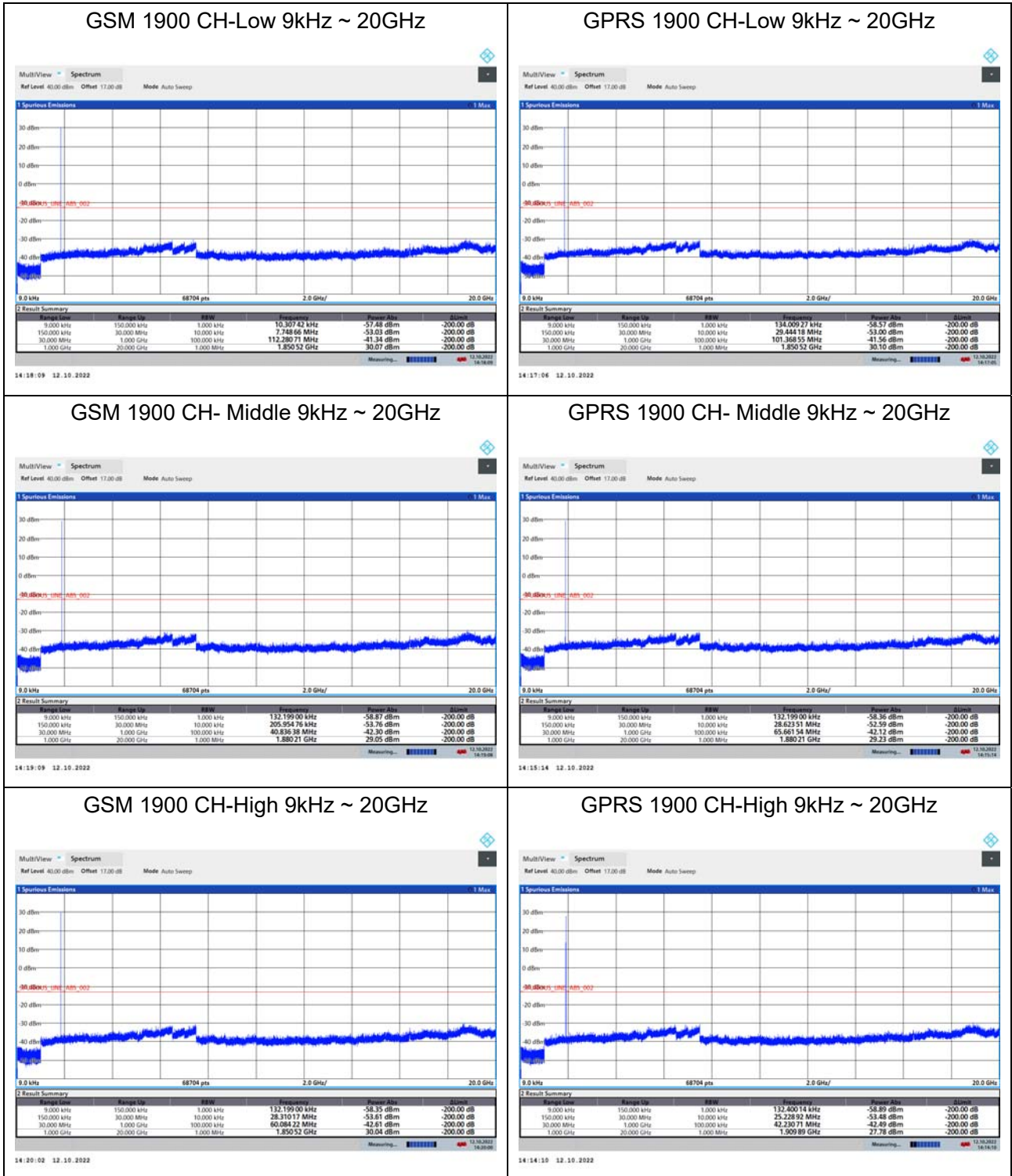



EGPRS 1900 CH-Low 9kHz ~ 20GHz

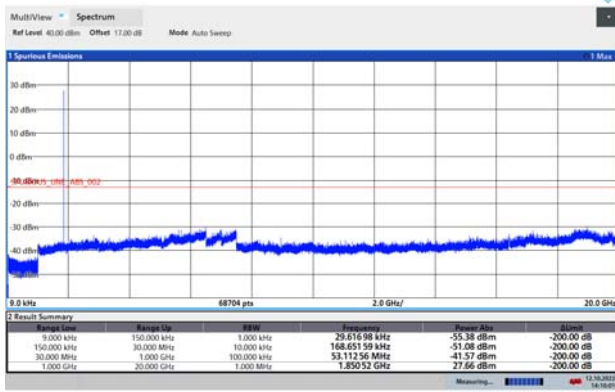

14:10:01 12.10.2022

WCDMA BAND II CH-Low 9kHz ~ 20GHz

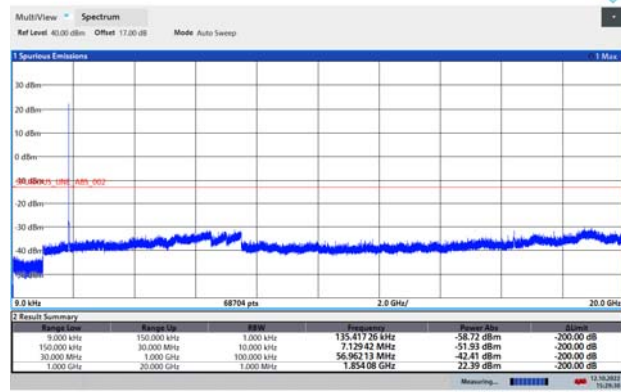

15:29:31 12.10.2022

EGPRS 1900 CH- Middle 9kHz ~ 20GHz

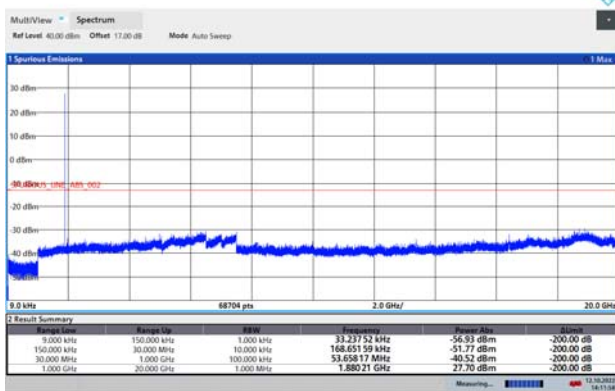

14:11:59 12.10.2022

WCDMA BAND II CH- Middle 9kHz ~ 20GHz

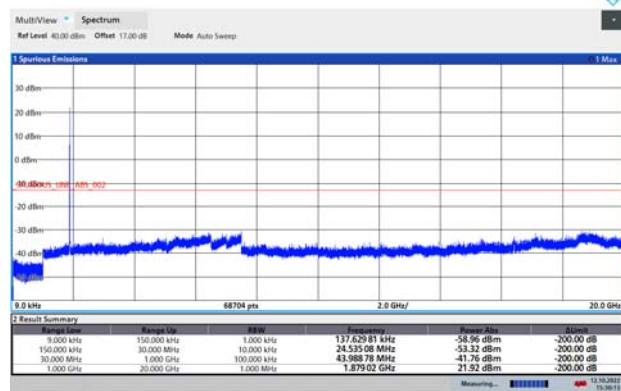

15:30:14 12.10.2022

EGPRS 1900 CH-High 9kHz ~ 20GHz

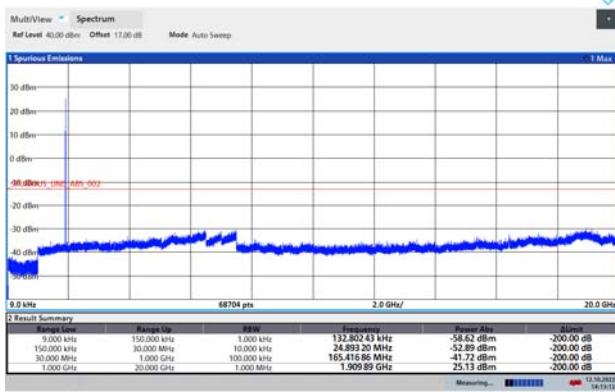

14:13:12 12.10.2022

WCDMA BAND II CH-High 9kHz ~ 20GHz

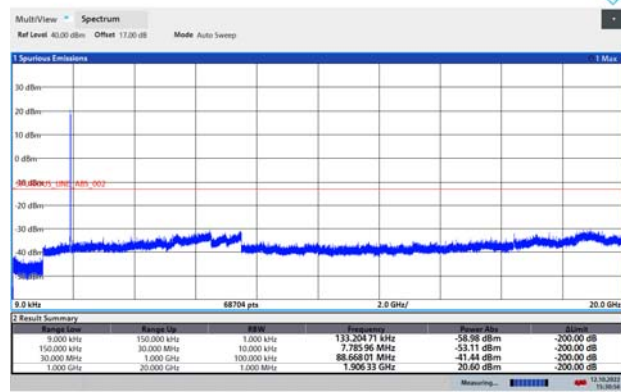

15:30:57 12.10.2022

LTE Band 2 1.4MHz CH-Low 9kHz~20GHz

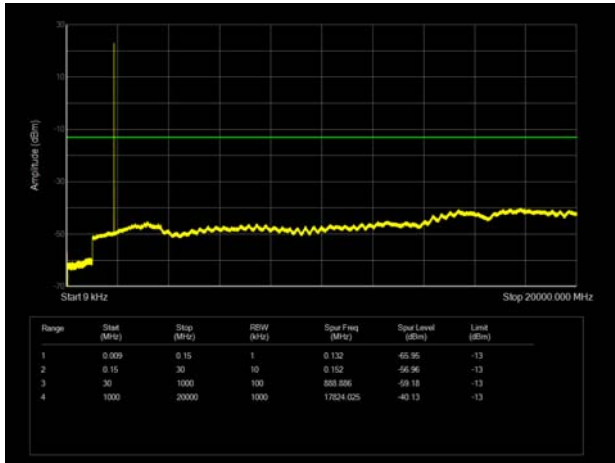

LTE Band 2 3MHz CH-Low 9kHz~20GHz

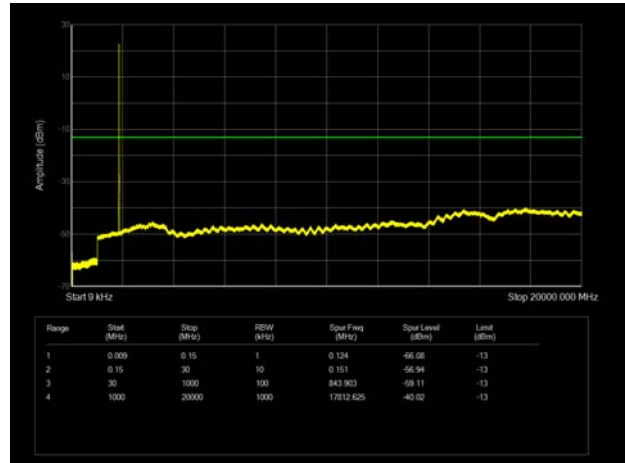

LTE Band 2 1.4MHz CH-Middle 9kHz~20GHz

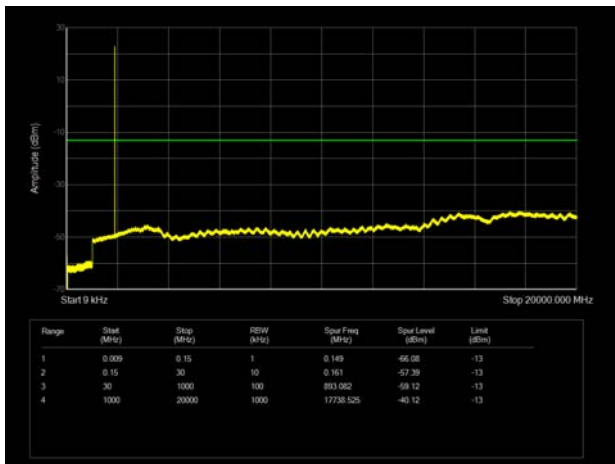

LTE Band 2 3MHz CH-Middle 9kHz~20GHz

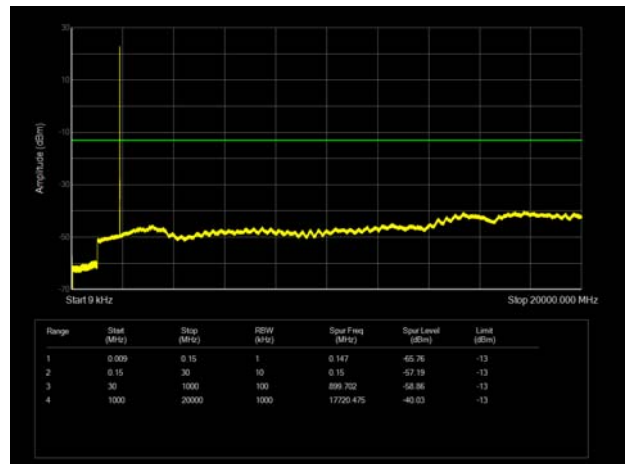

LTE Band 2 1.4MHz CH-High 9kHz~20GHz

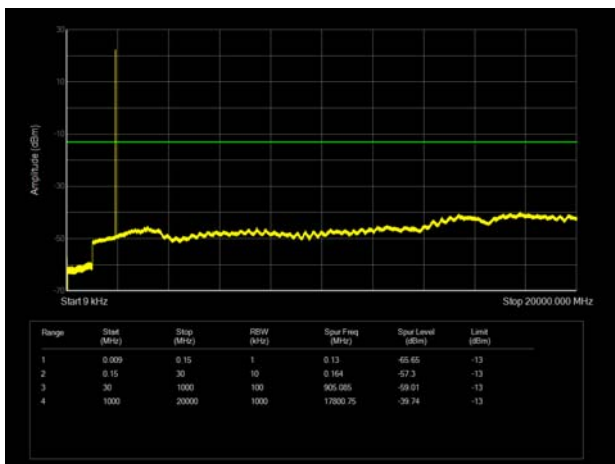

LTE Band 2 3MHz CH-High 9kHz~20GHz

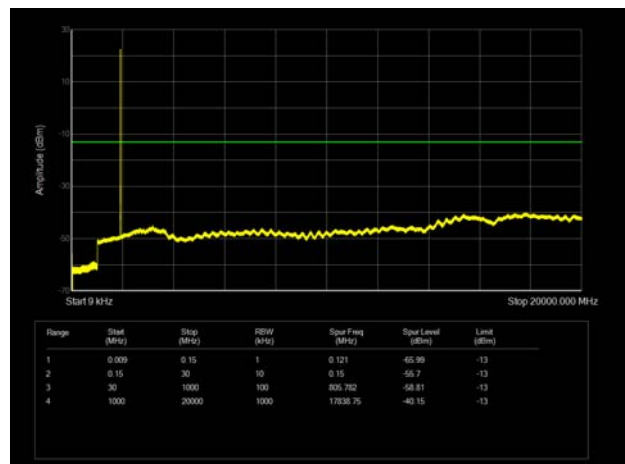

LTE Band 2 5MHz CH-Low 9kHz~20GHz

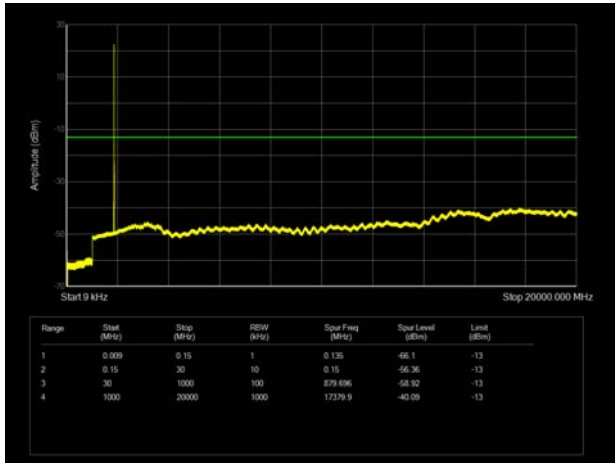

LTE Band 2 10MHz CH-Low 9kHz~20GHz

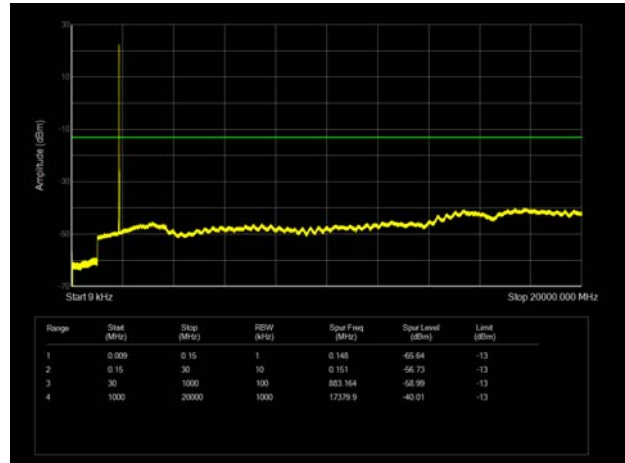

LTE Band 2 5MHz CH-Middle 9kHz~20GHz

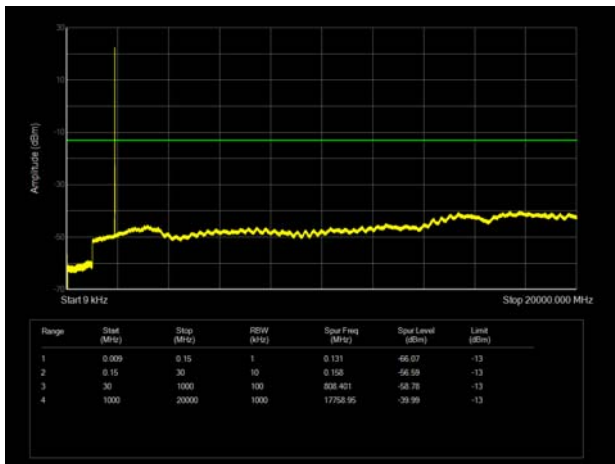

LTE Band 2 10MHz CH-Middle 9kHz~20GHz

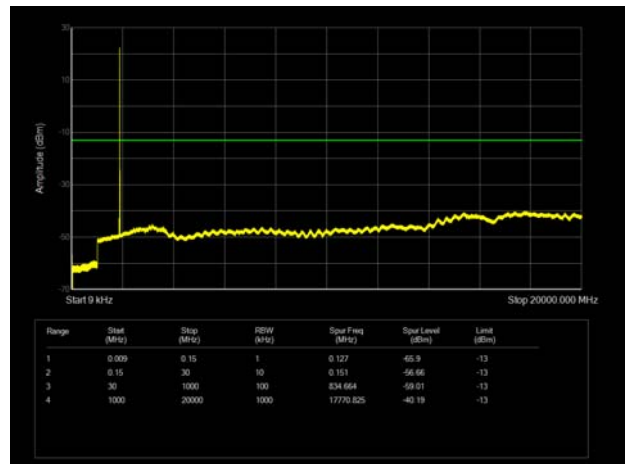

LTE Band 2 5MHz CH-High 9kHz~20GHz

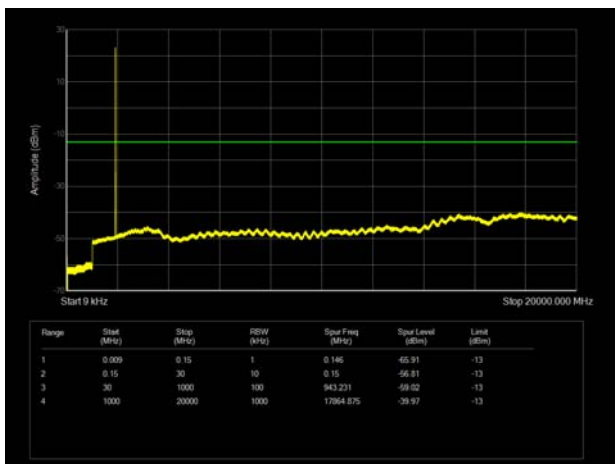

LTE Band 2 10MHz CH-High 9kHz~20GHz

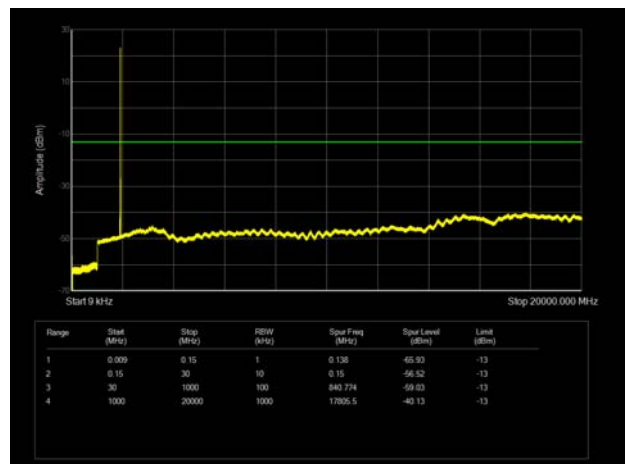

LTE Band 2 15MHz CH-Low 9kHz~20GHz

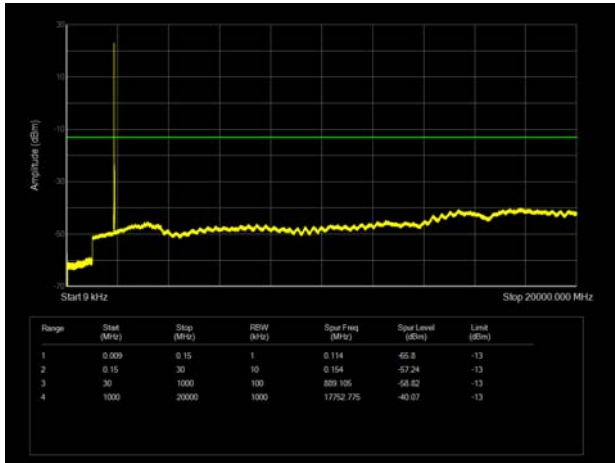

LTE Band 2 20MHz CH-Low 9kHz~20GHz

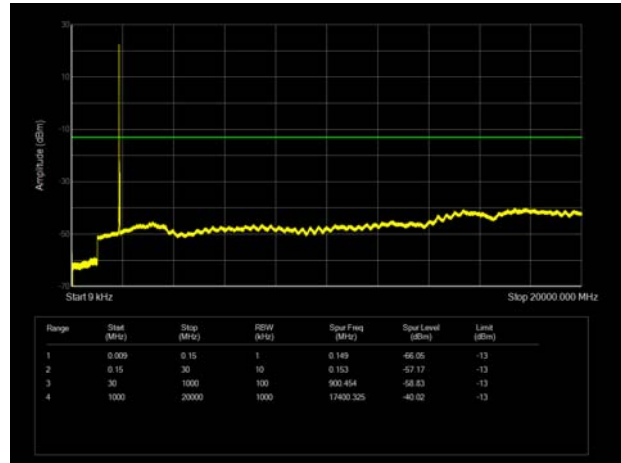

LTE Band 2 15MHz CH-Middle 9kHz~20GHz

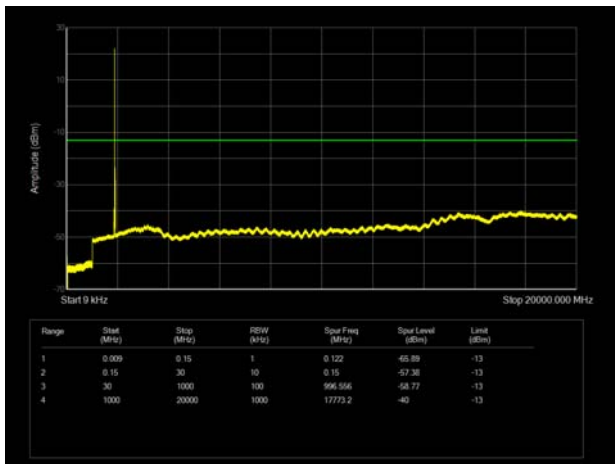

LTE Band 2 20MHz CH-Middle 9kHz~20GHz

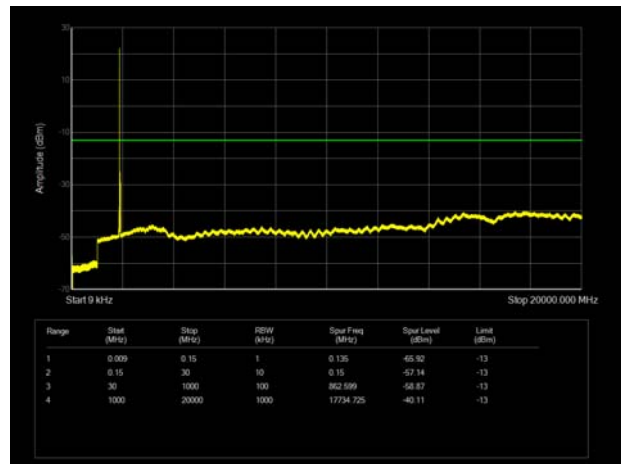

LTE Band 2 15MHz CH-High 9kHz~20GHz

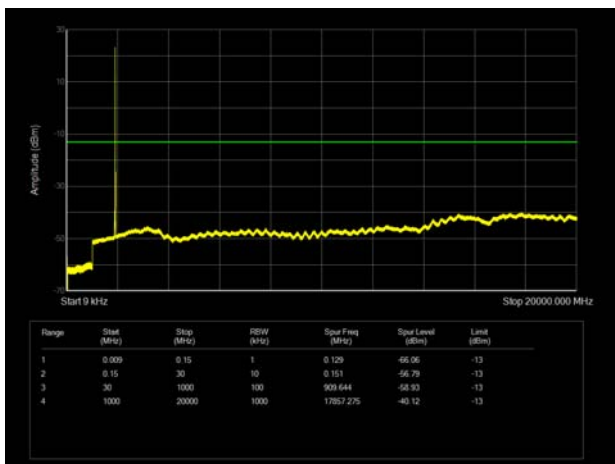

LTE Band 2 20MHz CH-High 9kHz~20GHz

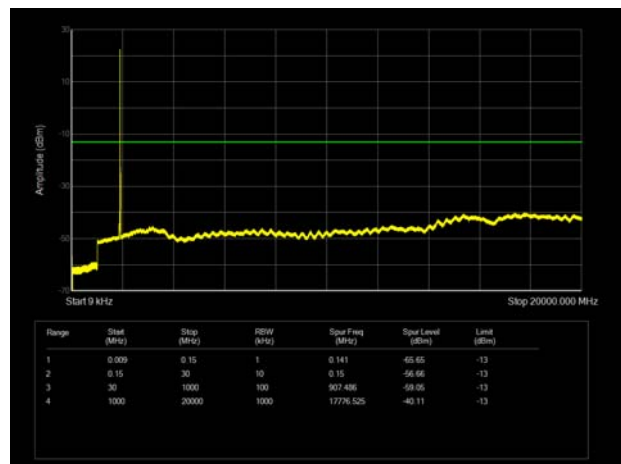

6.7. Radiated Spurious Emission

Sweep the whole frequency band through the range from 9kHz to the 10th harmonic of the carrier, the emissions below the noise floor will not be recorded in the report.

Upper Antenna

GSM 1900 CH-Middle

Harmonic	Frequency (MHz)	SG (dBm)	Cable Loss (dB)	Gain (dBi)	Antenna Polarization	EIRP Level (dBm)	Limit (dBm)	Margin (dB)	Azimuth (deg)
2	3760.00	-60.50	2.60	12.50	Vertical	-50.60	-13.00	37.60	29
3	5640.00	-61.26	3.30	12.50	Vertical	-52.06	-13.00	39.06	67
4	7520.00	-55.17	4.20	12.20	Vertical	-47.17	-13.00	34.17	158
5	9400.00	-52.92	4.30	11.10	Vertical	-46.12	-13.00	33.12	43
6	11280.00	-49.24	5.90	11.90	Vertical	-43.24	-13.00	30.24	201
7	13160.00	-51.91	5.70	14.00	Vertical	-43.61	-13.00	30.61	289
8	15040.00	-50.34	5.80	13.10	Vertical	-43.04	-13.00	30.04	127
9	16920.00	-50.64	6.10	14.60	Vertical	-42.14	-13.00	29.14	309
10	18800.00	-	-	-	-	-	-	-	-

Note: 1. The other Spurious RF Radiated emissions level is no more than noise floor.
 2. The worst emission was found in the antenna is Vertical position.

WCDMA Band II CH-Middle

Harmonic	Frequency (MHz)	SG (dBm)	Cable Loss (dB)	Gain (dBi)	Antenna Polarization	EIRP Level (dBm)	Limit (dBm)	Margin (dB)	Azimuth (deg)
2	3760.00	-62.81	2.60	12.50	Vertical	-52.91	-13.00	39.91	23
3	5640.00	-64.25	3.30	12.50	Vertical	-55.05	-13.00	42.05	61
4	7520.00	-58.22	4.20	12.20	Vertical	-50.22	-13.00	37.22	157
5	9400.00	-51.19	4.30	11.10	Vertical	-44.39	-13.00	31.39	16
6	11280.00	-49.77	5.90	11.90	Vertical	-43.77	-13.00	30.77	215
7	13160.00	-52.84	5.70	14.00	Vertical	-44.54	-13.00	31.54	301
8	15040.00	-52.21	5.80	13.10	Vertical	-44.91	-13.00	31.91	269
9	16920.00	-49.73	6.10	14.60	Vertical	-41.23	-13.00	28.23	58
10	18800.00	-	-	-	-	-	-	-	-

Note: 1. The other Spurious RF Radiated emissions level is no more than noise floor.
 2. The worst emission was found in the antenna is Vertical position.

LTE Band 2 1.4MHz CH-Middle

Harmonic	Frequency (MHz)	SG (dBm)	Cable Loss (dB)	Gain (dBi)	Antenna Polarization	EIRP Level (dBm)	Limit (dBm)	Margin (dB)	Azimuth (deg)
2	3759.40	-59.95	2.60	12.50	Vertical	-50.05	-13.00	37.05	90
3	5638.60	-63.66	3.30	12.50	Vertical	-54.46	-13.00	41.46	181
4	7520.00	-58.68	4.20	12.20	Vertical	-50.68	-13.00	37.68	0
5	9400.00	-50.26	4.30	11.10	Vertical	-43.46	-13.00	30.46	122
6	11280.00	-50.54	5.90	11.90	Vertical	-44.54	-13.00	31.54	250
7	13160.00	-53.09	5.70	14.00	Vertical	-44.79	-13.00	31.79	310
8	15040.00	-52.98	5.80	13.10	Vertical	-45.68	-13.00	32.68	45
9	16920.00	-50.06	6.10	14.60	Vertical	-41.56	-13.00	28.56	180
10	18800.00	-	-	-	-	-	-	-	-

Note: 1.The other Spurious RF Radiated emissions level is no more than noise floor.
 2. The worst emission was found in the antenna is Vertical position.

LTE Band 2 5MHz CH-Middle

Harmonic	Frequency (MHz)	SG (dBm)	Cable Loss (dB)	Gain (dBi)	Antenna Polarization	EIRP Level (dBm)	Limit (dBm)	Margin (dB)	Azimuth (deg)
2	3755.63	-61.43	2.60	12.50	Vertical	-51.53	-13.00	38.53	112
3	5633.63	-60.94	3.30	12.50	Vertical	-51.74	-13.00	38.74	311
4	7510.00	-58.41	4.20	12.20	Vertical	-50.41	-13.00	37.41	45
5	9387.50	-48.37	4.30	11.10	Vertical	-41.57	-13.00	28.57	135
6	11265.00	-51.63	5.90	11.90	Vertical	-45.63	-13.00	32.63	158
7	13142.00	-52.73	5.70	14.00	Vertical	-44.43	-13.00	31.43	236
8	15020.00	-51.33	5.80	13.10	Vertical	-44.03	-13.00	31.03	312
9	16897.50	-50.16	6.10	14.60	Vertical	-41.66	-13.00	28.66	77
10	18800.00	-	-	-	-	-	-	-	-

Note: 1.The other Spurious RF Radiated emissions level is no more than noise floor.
 2. The worst emission was found in the antenna is Vertical position.



LTE Band 2 20MHz CH-Middle

Harmonic	Frequency (MHz)	SG (dBm)	Cable Loss (dB)	Gain (dBi)	Antenna Polarization	EIRP Level (dBm)	Limit (dBm)	Margin (dB)	Azimuth (deg)
2	3742.13	-62.89	2.60	12.50	Vertical	-52.99	-13.00	39.99	155
3	5613.38	-60.29	3.30	12.50	Vertical	-51.09	-13.00	38.09	18
4	7484.63	-59.17	4.20	12.20	Vertical	-51.17	-13.00	38.17	311
5	9355.33	-47.45	4.30	11.10	Vertical	-40.65	-13.00	27.65	169
6	11226.39	-51.39	5.90	11.90	Vertical	-45.39	-13.00	32.39	122
7	13097.46	-52.62	5.70	14.00	Vertical	-44.32	-13.00	31.32	269
8	14968.52	-51.72	5.80	13.10	Vertical	-44.42	-13.00	31.42	133
9	16938.59	-50.96	6.10	14.60	Vertical	-42.46	-13.00	29.46	182
10	18800.00	-	-	-	-	-	-	-	-

Note: 1. The other Spurious RF Radiated emissions level is no more than noise floor.

2. The worst emission was found in the antenna is Vertical position.

**Low Antenna**

GSM 1900 CH-Middle

Harmonic	Frequency (MHz)	SG (dBm)	Cable Loss (dB)	Gain (dBi)	Antenna Polarization	EIRP Level (dBm)	Limit (dBm)	Margin (dB)	Azimuth (deg)
2	3760.00	-58.73	2.60	12.50	Horizontal	-48.83	-13.00	35.83	43
3	5640.00	-44.03	3.30	12.50	Horizontal	-34.83	-13.00	21.83	300
4	7520.00	-58.84	4.20	12.20	Horizontal	-50.84	-13.00	37.84	0
5	9400.00	-51.94	4.30	11.10	Horizontal	-45.14	-13.00	32.14	36
6	11280.00	-49.86	5.90	11.90	Horizontal	-43.86	-13.00	30.86	270
7	13160.00	-51.12	5.70	14.00	Horizontal	-42.82	-13.00	29.82	96
8	15040.00	-50.96	5.80	13.10	Horizontal	-43.66	-13.00	30.66	139
9	16920.00	-49.53	6.10	14.60	Horizontal	-41.03	-13.00	28.03	55
10	18800.00	-	-	-	-	-	-	-	-

Note: 1.The other Spurious RF Radiated emissions level is no more than noise floor.

2. The worst emission was found in the antenna is Horizontal position.

WCDMA Band II CH-Middle

Harmonic	Frequency (MHz)	SG (dBm)	Cable Loss (dB)	Gain (dBi)	Antenna Polarization	EIRP Level (dBm)	Limit (dBm)	Margin (dB)	Azimuth (deg)
2	3760.00	-57.54	2.60	12.50	Horizontal	-47.64	-13.00	34.64	180
3	5640.00	-47.91	3.30	12.50	Horizontal	-38.71	-13.00	25.71	25
4	7520.00	-58.04	4.20	12.20	Horizontal	-50.04	-13.00	37.04	322
5	9400.00	-49.01	4.30	11.10	Horizontal	-42.21	-13.00	29.21	290
6	11280.00	-51.03	5.90	11.90	Horizontal	-45.03	-13.00	32.03	272
7	13160.00	-53.14	5.70	14.00	Horizontal	-44.84	-13.00	31.84	135
8	15040.00	-50.71	5.80	13.10	Horizontal	-43.41	-13.00	30.41	28
9	16920.00	-50.56	6.10	14.60	Horizontal	-42.06	-13.00	29.06	18
10	18800.00	-	-	-	-	-	-	-	-

Note: 1.The other Spurious RF Radiated emissions level is no more than noise floor.

2. The worst emission was found in the antenna is Horizontal position.

LTE Band 2 1.4MHz CH-Middle

Harmonic	Frequency (MHz)	SG (dBm)	Cable Loss (dB)	Gain (dBi)	Antenna Polarization	EIRP Level (dBm)	Limit (dBm)	Margin (dB)	Azimuth (deg)
2	3759.00	-57.78	2.60	12.50	Vertical	-47.88	-13.00	34.88	135
3	5638.60	-38.65	3.30	12.50	Vertical	-29.45	-13.00	16.45	181
4	7520.00	-58.32	4.20	12.20	Vertical	-50.32	-13.00	37.32	0
5	9400.00	-46.63	4.30	11.10	Vertical	-39.83	-13.00	26.83	122
6	11280.00	-50.16	5.90	11.90	Vertical	-44.16	-13.00	31.16	250
7	13160.00	-51.77	5.70	14.00	Vertical	-43.47	-13.00	30.47	310
8	15040.00	-52.82	5.80	13.10	Vertical	-45.52	-13.00	32.52	45
9	16920.00	-50.57	6.10	14.60	Vertical	-42.07	-13.00	29.07	180
10	18800.00	-	-	-	-	-	-	-	-

Note: 1.The other Spurious RF Radiated emissions level is no more than noise floor.
 2. The worst emission was found in the antenna is Vertical position.

LTE Band 2 5MHz CH-Middle

Harmonic	Frequency (MHz)	SG (dBm)	Cable Loss (dB)	Gain (dBi)	Antenna Polarization	EIRP Level (dBm)	Limit (dBm)	Margin (dB)	Azimuth (deg)
2	3755.63	-57.44	2.60	12.50	Vertical	-47.54	-13.00	34.54	285
3	5633.63	-49.22	3.30	12.50	Vertical	-40.02	-13.00	27.02	311
4	7510.00	-58.65	4.20	12.20	Vertical	-50.65	-13.00	37.65	0
5	9387.50	-49.00	4.30	11.10	Vertical	-42.20	-13.00	29.20	135
6	11265.00	-51.16	5.90	11.90	Vertical	-45.16	-13.00	32.16	158
7	13142.00	-53.46	5.70	14.00	Vertical	-45.16	-13.00	32.16	246
8	15020.00	-52.08	5.80	13.10	Vertical	-44.78	-13.00	31.78	312
9	16897.50	-50.59	6.10	14.60	Vertical	-42.09	-13.00	29.09	85
10	18800.00	-	-	-	-	-	-	-	-

Note: 1.The other Spurious RF Radiated emissions level is no more than noise floor.
 2. The worst emission was found in the antenna is Vertical position.

LTE Band 2 20MHz CH-Middle

Harmonic	Frequency (MHz)	SG (dBm)	Cable Loss (dB)	Gain (dBi)	Antenna Polarization	EIRP Level (dBm)	Limit (dBm)	Margin (dB)	Azimuth (deg)
2	3742.13	-61.86	2.60	12.50	Vertical	-51.96	-13.00	38.96	155
3	5613.38	-53.48	3.30	12.50	Vertical	-44.28	-13.00	31.28	15
4	7484.63	-58.83	4.20	12.20	Vertical	-50.83	-13.00	37.83	312
5	9355.33	-50.45	4.30	11.10	Vertical	-43.65	-13.00	30.65	256
6	11226.39	-50.66	5.90	11.90	Vertical	-44.66	-13.00	31.66	133
7	13097.46	-52.67	5.70	14.00	Vertical	-44.37	-13.00	31.37	275
8	14968.52	-50.64	5.80	13.10	Vertical	-43.34	-13.00	30.34	135
9	16938.59	-50.21	6.10	14.60	Vertical	-41.71	-13.00	28.71	180
10	18800.00	-	-	-	-	-	-	-	-

Note: 1.The other Spurious RF Radiated emissions level is no more than noise floor.

2. The worst emission was found in the antenna is Vertical position.



7. Main Test Instruments

Name	Manufacturer	Type	Serial Number	Calibration Date	Expiration Date
Base Station Simulator	R&S	CMW500	150415	2022-05-14	2023-05-13
TRILOG Broadband Antenna	SCHWARZBECK	VULB 9163	1023	2020-05-05	2023-05-04
Spectrum Analyzer	Key sight	N9020A	MY50510203	2021-12-12	2022-12-11
Universal Radio Communication Tester	Key sight	E5515C	GB444400275	2021-12-12	2022-12-11
Signal Analyzer	R&S	FSV3030	101411	2021-12-12	2022-12-11
Climatic Chamber	ESPEC	SU-242	93000506	2021-12-12	2022-12-11
Spectrum Analyzer	R&S	FSV30	104028	2021-12-12	2022-12-11
Horn Antenna	Schwarzbeck	BBHA 9120D	1594	2020-12-17	2023-12-16
Horn Antenna	ETS-Lindgren	3160-09	00102643	2021-10-10	2024-10-09
Software	R&S	EMC32	10.35.10	/	/

*****END OF REPORT *****



ANNEX A: The EUT Appearance

The EUT Appearance is submitted separately.



ANNEX B: Test Setup Photos

The Test Setup Photos is submitted separately.