



Test Report No.: W7L-P23080006RF06



FCC TEST REPORT (PART 27)



Applicant:	Xiaomi Communications Co., Ltd.
Address:	#019, 9th Floor, Building 6, 33 Xi'erqi Middle Road, Haidian District, Beijing, China, 100085

Manufacturer or Supplier:	Xiaomi Communications Co., Ltd.
Address:	#019, 9th Floor, Building 6, 33 Xi'erqi Middle Road, Haidian District, Beijing, China, 100085
Product:	Mobile Phone
Brand Name:	Redmi
Model Name:	23100RN82L
FCC ID:	2AFZZN82L
Date of tests:	Aug. 07, 2023 ~ Sep. 12, 2023

The tests have been carried out according to the requirements of the following standard:

- FCC Part 27 ANSI/TIA/EIA-603-D
- FCC Part 2 ANSI/TIA/EIA-603-E ANSI C63.26-2015

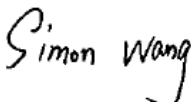
CONCLUSION: The submitted sample was found to COMPLY with the test requirement

Prepared by Simon Wang Engineer / Mobile Department	Approved by Luke Lu Manager / Mobile Department
 Date: Sep. 12, 2023	 Date: Sep. 12, 2023

This report is governed by, and incorporates by reference, the Conditions of Testing as posted at the date of issuance of this report at <http://www.bureauveritas.com/home/about-us/our-business/cps/about-us/terms-conditions/> and is intended for your exclusive use. Any copying or replication of this report to or for any other person or entity, or use of our name or trademark, is permitted only with our prior written permission. This report sets forth our findings solely with respect to the test samples identified herein. The results set forth in this report are not indicative or representative of the quality or characteristics of the lot from which a test sample was taken or any similar or identical product unless specifically and expressly noted. Our report includes all of the tests requested by you and the results thereof based upon the information that you provided to us. Measurement uncertainty is only provided upon request for accredited tests. Statements of conformity are based on simple acceptance criteria without taking measurement uncertainty into account, unless otherwise requested in writing. You have 60 days from date of issuance of this report to notify us of any material error or omission caused by our negligence or if you require measurement uncertainty; provided, however, that such notice shall be in writing and shall specifically address the issue you wish to raise. A failure to raise such issue within the prescribed time shall constitute your unqualified acceptance of the completeness of this report, the tests conducted and the correctness of the report contents.



TABLE OF CONTENTS

RELEASE CONTROL RECORD	4
1 SUMMARY OF TEST RESULTS	5
1.1 MEASUREMENT UNCERTAINTY	6
1.2 TEST SITE AND INSTRUMENTS	7
2 GENERAL INFORMATION	8
2.1 GENERAL DESCRIPTION OF EUT	8
2.2 CONFIGURATION OF SYSTEM UNDER TEST	11
2.3 DESCRIPTION OF SUPPORT UNITS	12
2.4 TEST ITEM AND TEST CONFIGURATION	12
2.5 GENERAL DESCRIPTION OF APPLIED STANDARDS	16
3 TEST TYPES AND RESULTS	17
3.1 OUTPUT POWER MEASUREMENT	17
3.1.1 LIMITS OF OUTPUT POWER MEASUREMENT	17
3.1.2 TEST PROCEDURES	17
3.1.3 TEST SETUP	18
3.1.4 TEST RESULTS	19
3.2 FREQUENCY STABILITY MEASUREMENT	45
3.2.1 LIMITS OF FREQUENCY STABILITY MEASUREMENT	45
3.2.2 TEST PROCEDURE	45
3.2.3 TEST SETUP	45
3.2.4 TEST RESULTS	46
3.3 OCCUPIED BANDWIDTH MEASUREMENT	47
3.3.1 LIMITS OF OCCUPIED BANDWIDTH MEASUREMENT	47
3.3.2 TEST SETUP	47
3.3.3 TEST PROCEDURES	47
3.3.4 TEST RESULTS	48
3.4 BAND EDGE MEASUREMENT	49
3.4.1 LIMITS OF BAND EDGE MEASUREMENT	49
3.4.2 TEST SETUP	50
3.4.3 TEST PROCEDURES	51
3.4.4 TEST RESULTS	52
3.5 CONDUCTED SPURIOUS EMISSIONS	53
3.5.1 LIMITS OF CONDUCTED SPURIOUS EMISSIONS MEASUREMENT	53
3.5.2 TEST PROCEDURE	53
3.5.3 TEST SETUP	53
3.5.4 TEST RESULTS	54
3.6 RADIATED EMISSION MEASUREMENT	55
3.6.1 LIMITS OF RADIATED EMISSION MEASUREMENT	55
3.6.2 TEST PROCEDURES	55
3.6.3 DEVIATION FROM TEST STANDARD	56
3.6.4 TEST SETUP	57
3.6.5 TEST RESULTS	59
3.7 PEAK TO AVERAGE RATIO	87
3.7.1 LIMITS OF PEAK TO AVERAGE RATIO MEASUREMENT	87
3.7.2 TEST SETUP	87
3.7.3 TEST PROCEDURES	87
3.7.4 TEST RESULTS	88
4 PHOTOGRAPHS OF THE TEST CONFIGURATION	89



**BUREAU
VERITAS**

Test Report No.:W7L-P23080006RF06

5 INFORMATION ON THE TESTING LABORATORIES	90
6 MODIFICATIONS RECORDERS FOR ENGINEERING CHANGES TO THE EUT BY THE LAB...	91
7 APPENDIX	92
WCDMA BAND4	92
LTE BAND7	106
LTE BAND13	158



Test Report No.:W7L-P23080006RF06

RELEASE CONTROL RECORD

ISSUE NO.	REASON FOR CHANGE	DATE ISSUED
W7L-P23080006RF06	Original release	Sep. 12, 2023

1 SUMMARY OF TEST RESULTS

The EUT has been tested according to the following specifications:

APPLIED STANDARD: FCC PART 27 & PART 2		
STANDARD SECTION	TEST TYPE AND LIMIT	RESULT
§2.1046	Conducted Output Power	Compliance
§27.50(b)(10)	Effective Radiated Power (Band 13)	Compliance
§27.50(d)(4) §27.50(h)(2)	Equivalent Isotropically Radiated Power (WCMDA Band 4)(Band 7)	Compliance
§2.1055 §27.54	Frequency Stability	Compliance
§2.1049	Occupied Bandwidth	Compliance
§2.1051 §27.53(c)(2)(4) §27.53(h) §27.53(m)(4)(6)	Conducted Band Edge Measurements (WCMDA Band 4) (Band 7) (Band 13)	Compliance
§2.1051 §27.53(c)(2)(4) §27.53(h) §27.53(m)(4)(6)	Conducted Spurious Emissions (WCMDA Band 4)(Band 7) (Band 13)	Compliance
§2.1053 §27.53(c)(2)(4) §27.53(f) §27.53(h) §27.53(m)(4)(6)	Radiated Spurious Emissions (WCMDA Band 4)(Band 7) (Band 13)	Compliance
NA	Peak to average ratio	Compliance

1.1 MEASUREMENT UNCERTAINTY

Where relevant, the following measurement uncertainty levels have been estimated for tests performed on the EUT as specified in CISPR 16-4-2:

MEASUREMENT	UNCERTAINTY
Frequency Stability	±76.97Hz
Radiated emissions (9KHz~30MHz)	±2.68dB
Radiated emissions & Radiated Power (30MHz~1GHz)	±4.98dB
Radiated emissions & Radiated Power (1GHz ~6GHz)	±4.70dB
Radiated emissions (6GHz ~18GHz)	±4.60dB
Radiated emissions (18GHz ~40GHz)	±4.12dB
Conducted emissions	±4.01dB
Occupied Channel Bandwidth	±43.58KHz
Conducted Output power	±2.06dB
Band Edge Measurements	±4.70dB

This uncertainty represents an expanded uncertainty expressed at approximately the 95% confidence level using a coverage factor of k=2.

1.2 TEST SITE AND INSTRUMENTS

Equipment	Manufacturer	Model No.	Serial No.	Last Cal.	Next Cal.
MXE EMI Receiver	KEYSIGHT	N9038A-544	MY54450026	Mar. 28,23	Mar. 27,24
EXA Signal Analyzer	KEYSIGHT	N9010A-544	MY54510355	May.10,23	May.09,24
Loop Antenna	Schwarzbeck	FMZB 1519B	00173	Sep.03,22	Sep.02,23
Loop Antenna	Schwarzbeck	FMZB 1519B	00173	Sep.02,23	Sep.01,24
Bilog Antenna	ETS-LINDGRE N	3143B	00161965	Feb. 18,23	Feb. 17,24
Horn Antenna	ETS-LINDGRE N	3117	00168692	Feb. 18,23	Feb. 17,24
Horn Antenna (18GHz-40GHz)	N/A	QWH-SL-18-40-K- SG/QMS-00361	15433	Sep.04, 22	Sep.03, 23
Horn Antenna (18GHz-40GHz)	N/A	QWH-SL-18-40-K- SG/QMS-00361	15433	Sep.03, 23	Sep.02, 24
Radio Communication Analyzer	ANRITSU	MT8820C	6201465426	Feb. 14,23	Feb. 13,24
Signal Pre-Amplifier	EMSI	EMC 9135	980249	May. 06,23	May. 05,24
Signal Pre-Amplifier	EMSI	EMC 012645B	980257	May.10,23	May.09,24
Signal Pre-Amplifier	EMSI	EMC 184045B	980259	Feb. 17,23	Feb.16,24
3m Semi-anechoic Chamber	ETS-LINDGRE N	9m*6m*6m	Euroshieldpn- CT0001143-121 6	May. 22, 23	May. 21,26
Test Software	E3	V 9.160323	N/A	N/A	N/A
Test Software	JS1120	3.1.36	N/A	N/A	N/A
10dB Attenuator	JFW/USA	50HF-010-SMA	50HF-010-SMA	May. 06,23	May. 05,24
Power Meter	Anritsu	ML2495A	1506002	Feb. 14,23	Feb. 13,24
Power Sensor	Anritsu	MA2411B	1339352	Feb. 14,23	Feb. 13,24
Temperature Chamber	ESPEC	SH-242	93000855	May. 06,23	May. 05,24
MXG Analog Microwave Signal Generator	KEYSIGHT	N5183A	MY50143024	Feb. 14,23	Feb. 13,24
Base station R&S CMW500	Rohde&Schwa rz	CMW500	153085	May.10,23	May.09,24
DC Source	Kikusui/JP	PMX18-5A	N/A	Aug. 11,23	Aug. 10,24

- NOTE:**
1. The calibration interval of the above test instruments is 12 months or 36 months and the calibrations are traceable to CEPREI/CHINA, GRGT/CHINA and NIM/CHINA.
 2. The test was performed in 3m Semi-anechoic Chamber and RF Oven Room.
 3. The horn antenna is used only for the measurement of emission frequency above 1GHz if tested.
 4. The FCC Site Registration No. is 525120; The Designation No. is CN1171.

2 GENERAL INFORMATION

2.1 GENERAL DESCRIPTION OF EUT

PRODUCT	Mobile Phone	
BRAND NAME	Redmi	
MODEL NAME	23100RN82L	
NOMINAL VOLTAGE	5Vdc(adapter or host equipment) 3.84Vdc (Li-ion, battery)	
MODULATION TECHNOLOGY	WCDMA IV	BPSK, QPSK
	LTE	QPSK, 16QAM, 64QAM
FREQUENCY RANGE	WCDMA IV	1712.4MHz ~ 1752.6MHz
	LTE Band 7 Channel Bandwidth: 5MHz	2502.5MHz ~ 2567.5MHz
	LTE Band 7 Channel Bandwidth: 10MHz	2505MHz ~ 2565MHz
	LTE Band 7 Channel Bandwidth: 15MHz	2507.5MHz ~ 2562.5MHz
	LTE Band 7 Channel Bandwidth: 20MHz	2510MHz ~ 2560MHz
	LTE Band 13 Channel Bandwidth: 5MHz	779.5MHz ~ 784.5MHz
	LTE Band 13 Channel Bandwidth: 10MHz	782MHz
MAX. EIRP POWER	WCDMA IV	125.89mW
	LTE Band 7 Channel Bandwidth: 5MHz	461.32mW
	LTE Band 7 Channel Bandwidth: 10MHz	463.45mW
	LTE Band 7 Channel Bandwidth: 15MHz	458.14mW
	LTE Band 7 Channel Bandwidth: 20MHz	464.52mW
	LTE Band 13 Channel Bandwidth: 5MHz	41.78mW
	LTE Band 13 Channel Bandwidth: 10MHz	41.98mW
EMISSION DESIGNATOR	WCDMA IV	4M18F9W
	LTE Band 7 Channel Bandwidth: 5MHz	QPSK: 4M50G7D
		16QAM: 4M50W7D
		64QAM: 4M50W7D



Test Report No.:W7L-P23080006RF06

EMISSION DESIGNATOR	LTE Band 7 Channel Bandwidth: 10MHz	QPSK:9M02G7D
		16QAM: 8M99W7D
		64QAM: 9M01W7D
	LTE Band 7 Channel Bandwidth: 15MHz	QPSK: 13M5G7D
		16QAM: 13M5W7D
		64QAM: 13M5W7D
	LTE Band 7 Channel Bandwidth: 20MHz	QPSK: 18M0G7D
		16QAM: 18M0W7D
		64QAM: 18M0W7D
	LTE Band 13 Channel Bandwidth: 5MHz	QPSK: 4M52G7D
		16QAM: 4M52W7D
		64QAM: 4M52W7D
LTE Band 13 Channel Bandwidth: 10MHz	QPSK: 9M00G7D	
	16QAM: 9M01W7D	
	64QAM: 8M99W7D	
ANTENNA TYPE	<p>ANT 0(UP): PIFA Antenna with -4.3dBi gain for WCDMA IV PIFA Antenna with -1.8dBi gain for LTE7 PIFA Antenna with -6.4dBi gain for LTE13</p> <p>ANT 1(DOWN): PIFA Antenna with -3.5dBi gain for WCDMA IV PIFA Antenna with 2dBi gain for LTE7 PIFA Antenna with -5.9dBi gain for LTE13</p>	
HW VERSION	LLDM572	
SW VERSION	MIUI 14	
IMEI	861440060049166 861440060064348 861440060081649	
I/O PORTS	Refer to user's manual	
CABLE SUPPLIED	USB cable1: non-shielded cable, with w/o ferrite core, 1.0 meter USB cable2: non-shielded cable, with w/o ferrite core, 1.0 meter	
EXTREME TEMPERATURE	0-40 °C	
EXTREME VOLTAGE	3.6V - 4.25V	



Test Report No.:W7L-P23080006RF06

NOTE:

1. For a more detailed features description, please refer to the manufacturer's specifications or the user's manual.
2. Physically, the EUT provides two completed transmitter and two receiver.

MODULATION MODE	TX FUNCTION
WCDMA	2TX/2RX
LTE	2TX/2RX

3. For the test results, the EUT had been tested with all conditions. But only the worst case was shown in the test report.

2.2 CONFIGURATION OF SYSTEM UNDER TEST

FOR RADIATION EMISSION TEST

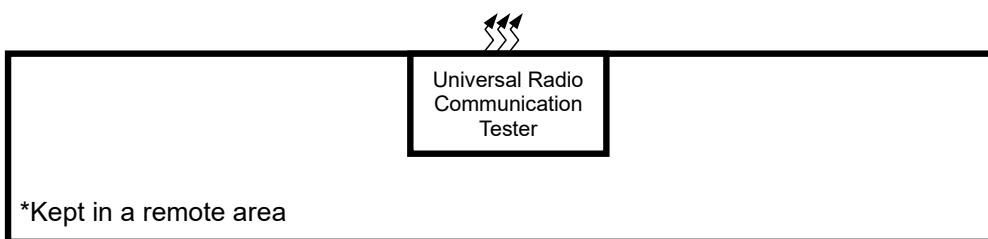
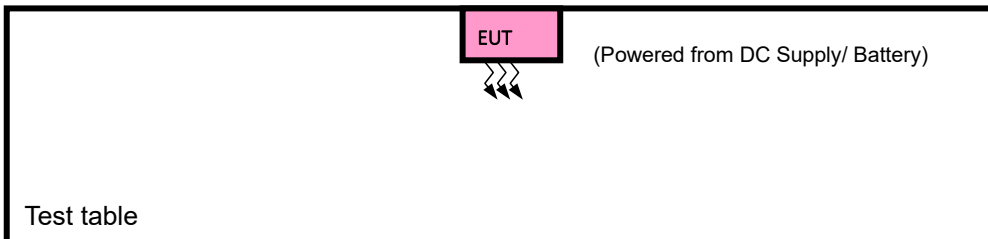
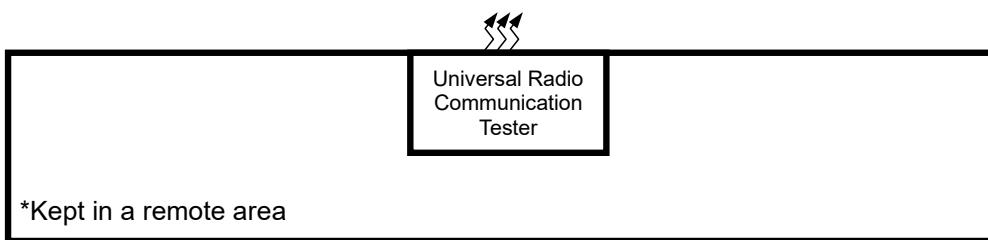
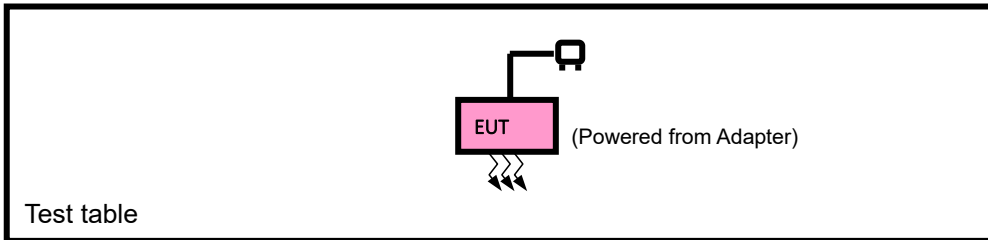

2.3 DESCRIPTION OF SUPPORT UNITS

The EUT has been tested as an independent unit together with other necessary accessories or support units. The following support units or accessories were used to form a representative test configuration during the tests.

NO.	PRODUCT	BRAND	MODEL NO.	SERIAL NO.	FCC ID
1	DC source	LONG WEI	PS-6403D	010934269	N/A

NO.	SIGNAL CABLE DESCRIPTION OF THE ABOVE SUPPORT UNITS
1	DC Line: Unshielded, Detachable 1.8m

2.4 TEST ITEM AND TEST CONFIGURATION

Pre-Scan has been conducted to determine the worst-case mode from all possible combinations between available modulations, data rates, XYZ axis and antenna ports. The worst case was found when positioned on Y-plane for EIRP and X-axis for radiated emission. Following channel(s) was (were) selected for the final test as listed below:

EUT CONFIGURE MODE	DESCRIPTION
A	EUT + Adapter + USB Cable with WCDMA or LTE link
B	EUT + DC source with GSM or WCDMA or LTE link

WCDMA MODE

EUT CONFIGURE MODE	TEST ITEM	AVAILABLE CHANNEL	TESTED CHANNEL	MODE
A	EIRP	1312 to 1513	1312, 1413, 1513	WCDMA
B	FREQUENCY STABILITY	1312 to 1513	1312, 1413, 1513	WCDMA
A	OCCUPIED BANDWIDTH	1312 to 1513	1312, 1413, 1513	WCDMA
A	BAND EDGE	1312 to 1513	1312, 1513	WCDMA
A	PEAK TO AVERAGE RATIO	1312 to 1513	1312, 1413, 1513	WCDMA
A	CONDCUDED EMISSION	1312 to 1513	1312, 1413, 1513	WCDMA
A	RADIATED EMISSION	1312 to 1513	1312, 1413, 1513	WCDMA

LTE BAND 7 MODE

EUT CONFIGURE MODE	TEST ITEM	AVAILABLE CHANNEL	TESTED CHANNEL	CHANNEL BANDWIDT H	MODULATION	MODE		
A	EIRP	20775 to 21425	20775, 21100, 21425	5MHz	QPSK, 16QAM, 64QAM	1 RB / 0 RB Offset		
		20800 to 21400	20800, 21100, 21400	10MHz	QPSK, 16QAM, 64QAM	1 RB / 0RB Offset		
		20825 to 21375	20825, 21100, 21375	15MHz	QPSK, 16QAM, 64QAM	1 RB / 0 RB Offset		
		20850 to 21350	20850, 21100, 21350	20MHz	QPSK, 16QAM, 64QAM	1 RB / 0 RB Offset		
B	FREQUENCY STABILITY	20850 to 21350	20850, 21100, 21350	20MHz	QPSK	100 RB / 0 RB Offset		
A	OCCUPIED BANDWIDTH	20775 to 21425	20775, 21100, 21425	5MHz	QPSK, 16QAM, 64QAM	25 RB / 0 RB Offset		
		20800 to 21400	20800, 21100, 21400	10MHz	QPSK, 16QAM, 64QAM	50 RB / 0 RB Offset		
		20825 to 21375	20825, 21100, 21375	15MHz	QPSK, 16QAM, 64QAM	75 RB / 0 RB Offset		
		20850 to 21350	20850, 21100, 21350	20MHz	QPSK, 16QAM, 64QAM	100 RB / 0 RB Offset		
A	PEAK TO AVERAGE RATIO	20850 to 21350	20850, 21100, 21350	20MHz	QPSK, 16QAM, 64QAM	1 RB / 0 RB Offset 100 RB / 0 RB Offset		
A	BAND EDGE	20775 to 21425	20775	5MHz	QPSK, 16QAM, 64QAM	1 RB / 0 RB Offset 25 RB / 0 RB Offset		
			21425	5MHz	QPSK, 16QAM, 64QAM	1 RB / 24 RB Offset 25 RB / 0 RB Offset		
		20800 to 21400	20800	10MHz	QPSK, 16QAM, 64QAM	1 RB / 0 RB Offset 50 RB / 0 RB Offset		
			21400	10MHz	QPSK, 16QAM, 64QAM	1 RB / 49 RB Offset 50 RB / 0 RB Offset		
		20825 to 21375	20825	15MHz	QPSK, 16QAM, 64QAM	1 RB / 0 RB Offset 75 RB / 0 RB Offset		
			21375	15MHz	QPSK, 16QAM, 64QAM	1 RB / 74 RB Offset 75 RB / 0 RB Offset		
		20850 to 21350	20850	20MHz	QPSK, 16QAM, 64QAM	1 RB / 0 RB Offset 100 RB / 0 RB Offset		
			21350	20MHz	QPSK, 16QAM, 64QAM	1 RB / 99 RB Offset 100 RB / 0 RB Offset		
		A	CONDCUDED EMISSION	20775 to 21425	20775, 21100, 21425	5MHz	QPSK	1 RB / 0 RB Offset
				20800 to 21400	20800, 21100, 21400	10MHz	QPSK	1 RB / 0RB Offset
				20825 to 21375	20825, 21100, 21375	15MHz	QPSK	1 RB / 0 RB Offset
				20850 to 21350	20850, 21100, 21350	20MHz	QPSK	1 RB / 0 RB Offset
A	RADIATED EMISSION	20775 to 21425	21100	5MHz	QPSK	1 RB / 0 RB Offset		
		20800 to 21400	20800, 21100, 21400	10MHz	QPSK	1 RB / 0 RB Offset		
		20825 to 21375	21100	15MHz	QPSK	1 RB / 0 RB Offset		
		20850 to 21350	21100	20MHz	QPSK	1 RB / 0 RB Offset		

Note: This device was tested under all bandwidths, RB configurations and modulations. The worst case was found in QPSK modulation.



Test Report No.:W7L-P23080006RF06

LTE BAND 13 MODE

EUT CONFIGURE MODE	TEST ITEM	AVAILABLE CHANNEL	TESTED CHANNEL	CHANNEL BANDWIDTH	MODULATION	MODE
A	ERP	23205 to 23255	23205, 23230, 23255	5MHz	QPSK,16QAM,64QAM	1 RB / 0 RB Offset
		23230	23230	10MHz	QPSK,16QAM,64QAM	1 RB / 0 RB Offset
B	FREQUENCY STABILITY	23230	23230	10MHz	QPSK,	50 RB / 0 RB Offset
A	OCCUPIED BANDWIDTH	23205 to 23255	23205, 23230, 23255	5MHz	QPSK,16QAM,64QAM	25 RB / 0 RB Offset
		23230	23230	10MHz	QPSK,16QAM,64QAM	50 RB / 0 RB Offset
A	PEAK TO AVERAGE RATIO	23230	23230	10MHz	QPSK,16QAM,64QAM	1 RB / 0 RB Offset 50 RB / 0 RB Offset
A	BAND EDGE	23205 to 23255	23205	5MHz	QPSK,16QAM, 64QAM	1 RB / 0 RB Offset 25 RB / 0 RB Offset
			23255	5MHz	QPSK,16QAM, 64QAM	1 RB / 24 RB Offset 25 RB / 0 RB Offset
		23230	23230	10MHz	QPSK,16QAM, 64QAM	1 RB / 0 RB Offset 1 RB / 49 RB Offset 50 RB / 0 RB Offset
			23230	10MHz	QPSK,16QAM, 64QAM	1 RB / 0 RB Offset
A	CONDCUDED EMISSION	23205 to 23255	23205, 23230, 23255	5MHz	QPSK	1 RB / 0 RB Offset
		23230	23230	10MHz	QPSK	1 RB / 0 RB Offset
A	RADIATED EMISSION	23205 to 23255	23205, 23230, 23255	5MHz	QPSK	1 RB / 0 RB Offset
		23230	23230	10MHz	QPSK	1 RB / 0 RB Offset

Note: This device was tested under all bandwidths, RB configurations and modulations. The worst case was found in QPSK modulation.



Test Report No.:W7L-P23080006RF06

TEST CONDITION:

TEST ITEM	ENVIRONMENTAL CONDITIONS	INPUT POWER	TESTED BY
ERP&EIRP	23deg. C, 70%RH	DC 5V By Adapter	Jace Hu
FREQUENCY STABILITY	See Note	DC 3.6/3.84/4.25 By DC Source	James Fu
OCCUPIED BANDWIDTH	23deg. C, 70%RH	DC 5V By Adapter	James Fu
BAND EDGE	23deg. C, 70%RH	DC 5V By Adapter	James Fu
CONDCUDED EMISSION	23deg. C, 70%RH	DC 5V By Adapter	James Fu
RADIATED EMISSION	23deg. C, 70%RH	DC 5V By Adapter	Jace Hu
PEAK TO AVERAGE RATIO	23deg. C, 70%RH	DC 5V By Adapter	James Fu

Note: LV = Low voltage (3.6V); NV = Normal voltage (3.84V); HV= High voltage (4.25V).
NT = Normal temperature (25°C)



Test Report No.:W7L-P23080006RF06

2.5 GENERAL DESCRIPTION OF APPLIED STANDARDS

The EUT is a RF product. According to the specifications of the manufacturer, it must comply with the requirements of the following standards:

FCC 47 CFR Part 2

FCC 47 CFR Part 27

KDB 971168 D01 Power Meas License Digital Systems v03r01

ANSI/TIA/EIA-603-D

ANSI/TIA/EIA-603-E

ANSI C63.26-2015

NOTE: All test items have been performed and recorded as per the above standards.



3 TEST TYPES AND RESULTS

3.1 OUTPUT POWER MEASUREMENT

3.1.1 LIMITS OF OUTPUT POWER MEASUREMENT

The radiated peak output power shall be according to the specific rule Part 27.50(h)(2) that “User stations are limited to 2 watts” and 27.50(i) specific that “Peak transmit power must be measure over any interval of continuous transmission using instrumentation calibration in terms of rms-equivalent voltage.”

Fixed, mobile, and portable (hand-held) stations operating in the 1710-1755 MHz band and mobile and portable stations operating in the 1695-1710 MHz and 1755-1780 MHz bands are limited to 1-watt EIRP

According to the specific rule Part 27.50(b)(10) Fixed, mobile, and Portable stations (hand-held devices) transmitting in the 776-788 MHz bands are limited to 3 watts ERP.

3.1.2 TEST PROCEDURES

EIRP MEASUREMENT:

Per KDB 971168 D01 Power Meas License Digital Systems v03r01 or subclause 5.2.5.5 of ANSI C63.26-2015, the relevant equation for determining the ERP or EIRP from the conducted RF output power measured using the guidance provided above is:

$$\text{ERP or EIRP} = P_{\text{Meas}} + G_{\text{T}} - L_{\text{C}}$$

Where:

ERP or EIRP = effective radiated power or equivalent isotropically radiated power, respectively
(expressed in the same units as P_{Meas} , typically dBW or dBm).

P_{Meas} = measured transmitter output power or PSD, in dBm or dBW.

G_{T} = gain of the transmitting antenna, in dBd (ERP) or dBi (EIRP).

L_{C} = signal attenuation in the connecting cable between the transmitter and antenna, in dB.

CONDUCTED POWER MEASUREMENT:

- a. The EUT was set up for the maximum power with LTE link data modulation and link up with simulator.
- b. Set the EUT to transmit under low, middle, and high channel and record the power level shown on simulator.



Test Report No.:W7L-P23080006RF06

3.1.3 TEST SETUP

CONDUCTED POWER MEASUREMENT:

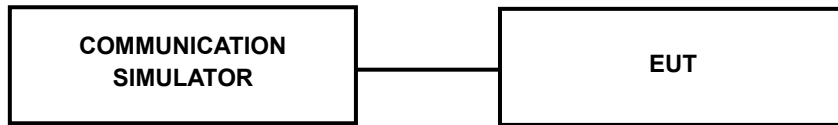

For the actual test configuration, please refer to the attached file (Test Setup Photo).

3.1.4 TEST RESULTS

CONDUCTED OUTPUT POWER (dBm)

ANT0(UP):

Band	WCDMA IV		
	1312	1413	1513
Channel	1712.4	1732.6	1752.6
Frequency (MHz)	1712.4	1732.6	1752.6
RMC 12.2K	24.26	24.41	24.27
HSDPA Subtest-1	23.48	23.36	23.34
HSDPA Subtest-2	23.42	23.46	23.41
HSDPA Subtest-3	22.51	22.36	22.36
HSDPA Subtest-4	22.51	22.37	22.35
DC-HSDPA Subtest-1	23.42	23.40	23.40
DC-HSDPA Subtest-2	23.52	23.41	23.41
DC-HSDPA Subtest-3	22.45	22.38	22.41
DC-HSDPA Subtest-4	22.50	22.45	22.35
HSUPA Subtest-1	21.50	21.44	21.36
HSUPA Subtest-2	21.46	21.40	21.40
HSUPA Subtest-3	22.46	22.41	22.44
HSUPA Subtest-4	20.93	20.89	20.91
HSUPA Subtest-5	22.49	22.44	22.41
HSPA+ Subtest-1	21.50	21.48	21.46

LTE Band 7

Band/BW	Modulation	RB Size	RB Offset	Low CH 20775	Mid CH 21100	High CH 21425
				Frequency 2502.5 MHz	Frequency 2535 MHz	Frequency 2567.5 MHz
7/5	QPSK	1	0	24.09	24.14	24.10
		1	12	24.28	24.37	24.46
		1	24	24.17	24.34	24.26
		12	0	23.41	23.16	23.18
		12	6	23.39	23.31	23.55
		12	13	23.43	23.35	23.47
		25	0	23.33	23.38	23.39
	16QAM	1	0	23.19	23.26	23.12
		1	12	23.45	23.48	23.58
		1	24	23.18	23.17	23.26
		12	0	22.30	22.27	22.37
		12	6	22.43	22.45	22.59
		12	13	22.37	22.46	22.41
		25	0	22.20	22.42	22.37
	64QAM	1	0	21.96	22.03	22.05
		1	12	22.31	22.18	22.39
		1	24	22.17	22.18	22.25
		12	0	21.15	21.04	20.98
		12	6	21.40	21.43	21.47
		12	13	21.38	21.21	21.31
		25	0	21.16	21.20	21.11



Test Report No.:W7L-P23080006RF06

Band/BW	Modulation	RB Size	RB Offset	Low CH 20800	Mid CH 21100	High CH 21400
				Frequency 2505 MHz	Frequency 2535 MHz	Frequency 2565 MHz
7/ 10	QPSK	1	0	24.14	24.13	24.16
		1	24	24.31	24.35	24.40
		1	49	24.28	24.37	24.19
		25	0	23.33	23.16	23.20
		25	12	23.34	23.35	23.56
		25	25	23.53	23.41	23.44
		50	0	23.33	23.33	23.42
	16QAM	1	0	23.10	23.29	23.17
		1	24	23.51	23.50	23.54
		1	49	23.25	23.20	23.33
		25	0	22.26	22.24	22.34
		25	12	22.45	22.45	22.49
		25	25	22.38	22.51	22.48
		50	0	22.27	22.37	22.33
	64QAM	1	0	22.07	22.01	22.05
		1	24	22.35	22.22	22.34
		1	49	22.10	22.18	22.21
		25	0	21.05	20.99	21.03
		25	12	21.37	21.48	21.46
		25	25	21.37	21.30	21.23
		50	0	21.18	21.28	21.15

Band/BW	Modulation	RB Size	RB Offset	Low CH 20825	Mid CH 21100	High CH 21375
				Frequency 2507.5 MHz	Frequency 2535 MHz	Frequency 2562.5 MHz
7/ 15	QPSK	1	0	24.05	24.13	24.14
		1	37	24.21	24.40	24.41
		1	74	24.18	24.32	24.30
		36	0	23.41	23.16	23.18
		36	19	23.36	23.31	23.61
		36	39	23.53	23.44	23.45
		75	0	23.38	23.34	23.31
	16QAM	1	0	23.09	23.23	23.08
		1	37	23.55	23.46	23.65
		1	74	23.20	23.19	23.30
		36	0	22.29	22.31	22.29
		36	19	22.52	22.47	22.49
		36	39	22.33	22.50	22.42
		75	0	22.22	22.42	22.34
	64QAM	1	0	21.99	22.02	22.06
		1	37	22.26	22.25	22.39
		1	74	22.11	22.15	22.18
		36	0	21.15	20.96	21.01
		36	19	21.33	21.49	21.47
		36	39	21.28	21.25	21.27
		75	0	21.13	21.27	21.12

Band/BW	Modulation	RB Size	RB Offset	Low CH 20850	Mid CH 21100	High CH 21350
				Frequency 2510 MHz	Frequency 2535 MHz	Frequency 2560 MHz
7/ 20	QPSK	1	0	24.16	24.15	24.18
		1	50	24.33	24.45	24.47
		1	99	24.28	24.42	24.30
		50	0	23.43	23.21	23.30
		50	25	23.54	23.46	23.65
		50	50	23.42	23.40	23.52
		100	0	23.41	23.40	23.43
	16QAM	1	0	23.19	23.31	23.20
		1	50	23.56	23.54	23.65
		1	99	23.28	23.29	23.34
		50	0	22.35	22.35	22.37
		50	25	22.53	22.50	22.61
		50	50	22.44	22.54	22.49
		100	0	22.29	22.47	22.42
	64QAM	1	0	22.08	22.11	22.16
		1	50	22.37	22.29	22.46
		1	99	22.21	22.22	22.25
		50	0	21.16	21.06	21.08
		50	25	21.44	21.53	21.57
		50	50	21.38	21.30	21.31
		100	0	21.22	21.29	21.21



**BUREAU
VERITAS**

Test Report No.:W7L-P23080006RF06

LTE Band 13

Band/BW	Modulation	RB Size	RB Offset	Low CH 23205	Mid CH 23230	High CH 23255
				Frequency 779.5 MHz	Frequency 782.0 MHz	Frequency 784.5 MHz
13/ 5	QPSK	1	0	24.10	24.06	24.05
		1	12	24.25	24.26	24.27
		1	24	24.03	24.03	23.98
		12	0	23.18	23.13	23.22
		12	6	23.24	23.15	23.20
		12	13	23.08	23.12	23.11
		25	0	23.18	23.13	23.15
	16QAM	1	0	23.26	23.28	23.21
		1	12	23.22	23.23	23.22
		1	24	23.12	23.11	23.11
		12	0	22.20	22.15	22.14
		12	6	22.11	22.10	22.17
		12	13	22.06	22.15	22.08
		25	0	22.12	22.04	22.08
	64QAM	1	0	22.15	22.09	22.13
		1	12	22.14	22.20	22.21
		1	24	22.15	22.11	22.17
		12	0	20.94	21.00	21.04
		12	6	21.25	21.24	21.30
		12	13	20.96	20.90	20.90
		25	0	21.10	21.16	21.13



Test Report No.:W7L-P23080006RF06

Band/BW	Modulation	RB Size	RB Offset	/	Mid CH 23230	/
				/	Frequency 782.0 MHz	/
13/ 10	QPSK	1	0	/	24.12	/
		1	24	/	24.30	/
		1	49	/	24.08	/
		25	0	/	23.23	/
		25	12	/	23.27	/
		25	25	/	23.18	/
		50	0	/	23.20	/
	16QAM	1	0	/	23.30	/
		1	24	/	23.28	/
		1	49	/	23.21	/
		25	0	/	22.21	/
		25	12	/	22.22	/
		25	25	/	22.18	/
		50	0	/	22.13	/
	64QAM	1	0	/	22.18	/
		1	24	/	22.25	/
		1	49	/	22.20	/
		25	0	/	21.05	/
		25	12	/	21.32	/
		25	25	/	20.99	/
		50	0	/	21.18	/



**BUREAU
VERITAS**

Test Report No.:W7L-P23080006RF06

ANT1(DOWN):

Band	WCDMA IV		
	1312	1413	1513
Channel	1712.4	1732.6	1752.6
Frequency (MHz)	1712.4	1732.6	1752.6
RMC 12.2K	24.50	24.44	24.43
HSDPA Subtest-1	23.42	23.44	23.40
HSDPA Subtest-2	23.43	23.35	23.40
HSDPA Subtest-3	22.42	22.40	22.35
HSDPA Subtest-4	22.45	22.39	22.40
DC-HSDPA Subtest-1	23.43	23.40	23.43
DC-HSDPA Subtest-2	23.40	23.38	23.42
DC-HSDPA Subtest-3	22.41	22.36	22.36
DC-HSDPA Subtest-4	22.41	22.35	22.37
HSUPA Subtest-1	20.97	21.04	21.08
HSUPA Subtest-2	21.02	21.05	21.08
HSUPA Subtest-3	22.03	22.07	22.05
HSUPA Subtest-4	20.55	20.55	20.57
HSUPA Subtest-5	22.00	22.06	22.06
HSPA+ Subtest-1	21.07	21.01	21.06

LTE Band 7

Band/BW	Modulation	RB Size	RB Offset	Low CH 20775	Mid CH 21100	High CH 21425
				Frequency 2502.5 MHz	Frequency 2535 MHz	Frequency 2567.5 MHz
7/5	QPSK	1	0	24.40	24.38	24.42
		1	12	24.50	24.40	24.64
		1	24	24.24	24.28	24.41
		12	0	23.37	23.45	23.56
		12	6	23.39	23.21	23.59
		12	13	23.16	23.37	23.63
		25	0	23.37	23.45	23.53
	16QAM	1	0	23.48	23.25	23.44
		1	12	23.16	23.28	23.63
		1	24	23.31	23.44	23.43
		12	0	22.36	22.47	22.53
		12	6	22.42	22.42	22.63
		12	13	22.23	22.33	22.57
		25	0	22.25	22.34	22.57
	64QAM	1	0	22.32	22.19	22.39
		1	12	22.27	22.18	22.39
		1	24	22.21	22.27	22.32
		12	0	21.35	21.25	21.11
		12	6	21.38	21.33	21.48
		12	13	21.37	21.36	21.40
		25	0	21.43	21.58	21.44

Band/BW	Modulation	RB Size	RB Offset	Low CH 20800	Mid CH 21100	High CH 21400
				Frequency 2505 MHz	Frequency 2535 MHz	Frequency 2565 MHz
7/ 10	QPSK	1	0	24.36	24.33	24.33
		1	24	24.57	24.35	24.66
		1	49	24.31	24.34	24.48
		25	0	23.35	23.39	23.64
		25	12	23.40	23.22	23.66
		25	25	23.16	23.31	23.62
		50	0	23.36	23.51	23.55
	16QAM	1	0	23.41	23.37	23.42
		1	24	23.20	23.27	23.66
		1	49	23.37	23.44	23.39
		25	0	22.32	22.42	22.59
		25	12	22.47	22.34	22.59
		25	25	22.17	22.40	22.57
		50	0	22.24	22.36	22.52
	64QAM	1	0	22.38	22.28	22.44
		1	24	22.32	22.13	22.42
		1	49	22.26	22.26	22.33
		25	0	21.34	21.24	21.16
		25	12	21.32	21.36	21.44
		25	25	21.45	21.37	21.39
		50	0	21.51	21.63	21.44

Band/BW	Modulation	RB Size	RB Offset	Low CH 20825	Mid CH 21100	High CH 21375
				Frequency 2507.5 MHz	Frequency 2535 MHz	Frequency 2562.5 MHz
7/ 15	QPSK	1	0	24.30	24.35	24.40
		1	37	24.59	24.36	24.61
		1	74	24.27	24.28	24.48
		36	0	23.35	23.43	23.53
		36	19	23.35	23.27	23.62
		36	39	23.13	23.37	23.55
		75	0	23.32	23.53	23.56
	16QAM	1	0	23.44	23.26	23.37
		1	37	23.23	23.29	23.64
		1	74	23.29	23.36	23.41
		36	0	22.31	22.44	22.62
		36	19	22.40	22.36	22.55
		36	39	22.18	22.40	22.55
		75	0	22.27	22.33	22.53
	64QAM	1	0	22.32	22.27	22.41
		1	37	22.32	22.16	22.44
		1	74	22.20	22.18	22.31
		36	0	21.35	21.26	21.17
		36	19	21.29	21.32	21.42
		36	39	21.35	21.44	21.39
		75	0	21.52	21.55	21.46

Band/BW	Modulation	RB Size	RB Offset	Low CH 20850	Mid CH 21100	High CH 21350
				Frequency 2510 MHz	Frequency 2535 MHz	Frequency 2560 MHz
7/ 20	QPSK	1	0	24.40	24.41	24.43
		1	50	24.60	24.46	24.67
		1	99	24.32	24.35	24.49
		50	0	23.40	23.39	23.65
		50	25	23.46	23.48	23.68
		50	50	23.24	23.43	23.64
		100	0	23.37	23.53	23.62
	16QAM	1	0	23.52	23.37	23.48
		1	50	23.26	23.31	23.69
		1	99	23.41	23.45	23.50
		50	0	22.43	22.49	22.64
		50	25	22.51	22.42	22.66
		50	50	22.29	22.42	22.62
		100	0	22.35	22.43	22.59
	64QAM	1	0	22.41	22.29	22.44
		1	50	22.33	22.25	22.46
		1	99	22.31	22.28	22.38
		50	0	21.37	21.34	21.23
		50	25	21.38	21.37	21.50
		50	50	21.46	21.48	21.42
		100	0	21.53	21.63	21.47



**BUREAU
VERITAS**

Test Report No.:W7L-P23080006RF06

LTE Band 13

Band/BW	Modulation	RB Size	RB Offset	Low CH 23205	Mid CH 23230	High CH 23255
				Frequency 779.5 MHz	Frequency 782.0 MHz	Frequency 784.5 MHz
13/ 5	QPSK	1	0	24.03	24.02	23.99
		1	12	24.20	24.26	24.22
		1	24	24.05	24.07	24.06
		12	0	23.11	23.15	23.09
		12	6	23.18	23.20	23.17
		12	13	23.07	23.09	23.12
		25	0	23.16	23.23	23.13
	16QAM	1	0	23.04	23.03	23.09
		1	12	23.17	23.20	23.27
		1	24	23.13	23.12	23.16
		12	0	22.13	22.10	22.10
		12	6	22.11	22.16	22.15
		12	13	22.12	22.06	22.09
		25	0	22.12	22.13	22.17
	64QAM	1	0	22.13	22.08	22.09
		1	12	22.10	22.03	22.07
		1	24	22.08	22.16	22.08
		12	0	21.10	21.09	21.20
		12	6	21.19	21.17	21.11
		12	13	21.13	21.10	21.04
		25	0	21.02	21.08	21.00



Test Report No.:W7L-P23080006RF06

Band/BW	Modulation	RB Size	RB Offset	/	Mid CH 23230	/
				/	Frequency 782.0 MHz	/
13/ 10	QPSK	1	0	/	24.05	/
		1	24	/	24.28	/
		1	49	/	24.07	/
		25	0	/	23.16	/
		25	12	/	23.26	/
		25	25	/	23.13	/
		50	0	/	23.24	/
	16QAM	1	0	/	23.13	/
		1	24	/	23.28	/
		1	49	/	23.19	/
		25	0	/	22.16	/
		25	12	/	22.21	/
		25	25	/	22.14	/
		50	0	/	22.22	/
	64QAM	1	0	/	22.16	/
		1	24	/	22.14	/
		1	49	/	22.19	/
		25	0	/	21.21	/
		25	12	/	21.22	/
		25	25	/	21.16	/
		50	0	/	21.10	/



**BUREAU
VERITAS**

Test Report No.:W7L-P23080006RF06

EIRP

ANT0(UP):

WCDMA IV

Channel	Frequency (MHz)	Conducted Power (dBm)	G _T -L _c (dB)	EIRP (dBm)	EIRP (mW)	Limit (W)
1312	1712.4	24.26	-4.3	19.96	99.08	1
1413	1732.6	24.41	-4.3	20.11	102.57	1
1513	1752.6	24.27	-4.3	19.97	99.31	1

LTE BAND 7

CHANNEL BANDWIDTH: 5MHz QPSK

Channel	Frequency (MHz)	Conducted Power (dBm)	G _T -L _c (dB)	EIRP (dBm)	EIRP (mW)	Limit (W)
20775	2502.5	24.28	-1.8	22.48	177.01	2
21100	2535.0	24.37	-1.8	22.57	180.72	2
21425	2567.5	24.46	-1.8	22.66	184.5	2

CHANNEL BANDWIDTH: 5MHz 16QAM

Channel	Frequency (MHz)	Conducted Power (dBm)	G _T -L _c (dB)	EIRP (dBm)	EIRP (mW)	Limit (W)
20775	2502.5	23.45	-1.8	21.65	146.22	2
21100	2535.0	23.48	-1.8	21.68	147.23	2
21425	2567.5	23.58	-1.8	21.78	150.66	2

CHANNEL BANDWIDTH: 5MHz 64QAM

Channel	Frequency (MHz)	Conducted Power (dBm)	G _T -L _c (dB)	EIRP (dBm)	EIRP (mW)	Limit (W)
20775	2502.5	22.31	-1.8	20.51	112.46	2
21100	2535	22.18	-1.8	20.38	109.14	2
21425	2567.5	22.39	-1.8	20.59	114.55	2

CHANNEL BANDWIDTH: 10MHz QPSK

Channel	Frequency (MHz)	Conducted Power (dBm)	G _T -L _c (dB)	EIRP (dBm)	EIRP (mW)	Limit (W)
20800	2505.0	24.31	-1.8	22.51	178.24	2
21100	2535.0	24.37	-1.8	22.57	180.72	2
21400	2565.0	24.4	-1.8	22.6	181.97	2

CHANNEL BANDWIDTH: 10MHz 16QAM

Channel	Frequency (MHz)	Conducted Power (dBm)	G _T -L _c (dB)	EIRP (dBm)	EIRP (mW)	Limit (W)
20800	2505.0	23.51	-1.8	21.71	148.25	2
21100	2535.0	23.5	-1.8	21.7	147.91	2
21400	2565.0	23.54	-1.8	21.74	149.28	2

CHANNEL BANDWIDTH: 10MHz 64QAM

Channel	Frequency (MHz)	Conducted Power (dBm)	G _T -L _c (dB)	EIRP (dBm)	EIRP (mW)	Limit (W)
20800	2505	22.35	-1.8	20.55	113.5	2
21100	2535	22.22	-1.8	20.42	110.15	2
21400	2565	22.34	-1.8	20.54	113.24	2



Test Report No.:W7L-P23080006RF06

CHANNEL BANDWIDTH: 15MHz QPSK

Channel	Frequency (MHz)	Conducted Power (dBm)	G _T -L _c (dB)	EIRP (dBm)	EIRP (mW)	Limit (W)
20825	2507.5	24.21	-1.8	22.41	174.18	2
21100	2535.0	24.4	-1.8	22.6	181.97	2
21375	2562.5	24.41	-1.8	22.61	182.39	2

CHANNEL BANDWIDTH: 15MHz 16QAM

Channel	Frequency (MHz)	Conducted Power (dBm)	G _T -L _c (dB)	EIRP (dBm)	EIRP (mW)	Limit (W)
20825	2507.5	23.55	-1.8	21.75	149.62	2
21100	2535.0	23.46	-1.8	21.66	146.55	2
21375	2562.5	23.65	-1.8	21.85	153.11	2

CHANNEL BANDWIDTH: 15MHz 64QAM

Channel	Frequency (MHz)	Conducted Power (dBm)	G _T -L _c (dB)	EIRP (dBm)	EIRP (mW)	Limit (W)
20825	2507.5	22.26	-1.8	20.46	111.17	2
21100	2535	22.25	-1.8	20.45	110.92	2
21375	2562.5	22.39	-1.8	20.59	114.55	2



**BUREAU
VERITAS**

Test Report No.:W7L-P23080006RF06

CHANNEL BANDWIDTH: 20MHz QPSK

Channel	Frequency (MHz)	Conducted Power (dBm)	G _T -L _c (dB)	EIRP (dBm)	EIRP (mW)	Limit (W)
20850	2510.0	24.33	-1.8	22.53	179.06	2
21100	2535.0	24.45	-1.8	22.65	184.08	2
21350	2560.0	24.47	-1.8	22.67	184.93	2

CHANNEL BANDWIDTH: 20MHz 16QAM

Channel	Frequency (MHz)	Conducted Power (dBm)	G _T -L _c (dB)	EIRP (dBm)	EIRP (mW)	Limit (W)
20850	2510.0	23.56	-1.8	21.76	149.97	2
21100	2535.0	23.54	-1.8	21.74	149.28	2
21350	2560.0	23.65	-1.8	21.85	153.11	2

CHANNEL BANDWIDTH: 20MHz 64QAM

Channel	Frequency (MHz)	Conducted Power (dBm)	G _T -L _c (dB)	EIRP (dBm)	EIRP (mW)	Limit (W)
20850	2510	22.37	-1.8	20.57	114.02	2
21100	2535	22.29	-1.8	20.49	111.94	2
21350	2560	22.46	-1.8	20.66	116.41	2

REMARKS: ERP Output Power (dBm) = EIRP (dBm) -2.15(dB).



**BUREAU
VERITAS**

Test Report No.:W7L-P23080006RF06

LTE BAND 13

CHANNEL BANDWIDTH: 5MHz QPSK

Channel	Frequency (MHz)	Conducted Power (dBm)	G _T -L _c (dB)	ERP (dBm)	ERP (mW)	Limit (W)
23205	779.5	24.25	-6.4	15.7	37.15	3
23230	782	24.26	-6.4	15.71	37.24	3
23255	784.5	24.27	-6.4	15.72	37.33	3

CHANNEL BANDWIDTH: 5MHz 16QAM

Channel	Frequency (MHz)	Conducted Power (dBm)	G _T -L _c (dB)	ERP (dBm)	ERP (mW)	Limit (W)
23205	779.5	23.26	-6.4	14.71	29.58	3
23230	782	23.28	-6.4	14.73	29.72	3
23255	784.5	23.22	-6.4	14.67	29.31	3

CHANNEL BANDWIDTH: 5MHz 64QAM

Channel	Frequency (MHz)	Conducted Power (dBm)	G _T -L _c (dB)	ERP (dBm)	ERP (mW)	Limit (W)
23205	779.5	22.15	-6.4	13.6	22.91	3
23230	782	22.2	-6.4	13.65	23.17	3
23255	784.5	22.21	-6.4	13.66	23.23	3

CHANNEL BANDWIDTH: 10MHz QPSK

Channel	Frequency (MHz)	Conducted Power (dBm)	G _T -L _c (dB)	ERP (dBm)	ERP (mW)	Limit (W)
-	-	-	-	-	-	-
23230	782	24.3	-6.4	15.75	37.58	3
-	-	-	-	-	-	-

CHANNEL BANDWIDTH: 10MHz 16QAM

Channel	Frequency (MHz)	Conducted Power (dBm)	G _T -L _c (dB)	ERP (dBm)	ERP (mW)	Limit (W)
-	-	-	-	-	-	-
23230	782	23.3	-6.4	14.75	29.85	3
-	-	-	-	-	-	-

CHANNEL BANDWIDTH: 10MHz 64QAM

Channel	Frequency (MHz)	Conducted Power (dBm)	G _T -L _c (dB)	ERP (dBm)	ERP (mW)	Limit (W)
-	-	-	-	-	-	-
23230	782	22.25	-6.4	13.7	23.44	3
-	-	-	-	-	-	-

REMARKS: ERP Output Power (dBm) = EIRP (dBm) -2.15(dB).

ANT1(DOWN):

WCDMA IV

Channel	Frequency (MHz)	Conducted Power (dBm)	G _T -L _c (dB)	EIRP (dBm)	EIRP (mW)	Limit (W)
1312	1712.4	24.5	-3.5	21	125.89	1
1413	1732.6	24.44	-3.5	20.94	124.17	1
1513	1752.6	24.43	-3.5	20.93	123.88	1

LTE BAND 7

CHANNEL BANDWIDTH: 5MHz QPSK

Channel	Frequency (MHz)	Conducted Power (dBm)	G _T -L _c (dB)	EIRP (dBm)	EIRP (mW)	Limit (W)
20775	2502.5	24.5	2	26.5	446.68	2
21100	2535.0	24.4	2	26.4	436.52	2
21425	2567.5	24.64	2	26.64	461.32	2

CHANNEL BANDWIDTH: 5MHz 16QAM

Channel	Frequency (MHz)	Conducted Power (dBm)	G _T -L _c (dB)	EIRP (dBm)	EIRP (mW)	Limit (W)
20775	2502.5	23.48	2	25.48	353.18	2
21100	2535.0	23.44	2	25.44	349.95	2
21425	2567.5	23.63	2	25.63	365.59	2

CHANNEL BANDWIDTH: 5MHz 64QAM

Channel	Frequency (MHz)	Conducted Power (dBm)	G _T -L _c (dB)	EIRP (dBm)	EIRP (mW)	Limit (W)
20775	2502.5	22.32	2	24.32	270.4	2
21100	2535	22.27	2	24.27	267.3	2
21425	2567.5	22.39	2	24.39	274.79	2

CHANNEL BANDWIDTH: 10MHz QPSK

Channel	Frequency (MHz)	Conducted Power (dBm)	G _T -L _c (dB)	EIRP (dBm)	EIRP (mW)	Limit (W)
20800	2505.0	24.57	2	26.57	453.94	2
21100	2535.0	24.35	2	26.35	431.52	2
21400	2565.0	24.66	2	26.66	463.45	2

CHANNEL BANDWIDTH: 10MHz 16QAM

Channel	Frequency (MHz)	Conducted Power (dBm)	G _T -L _c (dB)	EIRP (dBm)	EIRP (mW)	Limit (W)
20800	2505.0	23.41	2	25.41	347.54	2
21100	2535.0	23.44	2	25.44	349.95	2
21400	2565.0	23.66	2	25.66	368.13	2

CHANNEL BANDWIDTH: 10MHz 64QAM

Channel	Frequency (MHz)	Conducted Power (dBm)	G _T -L _c (dB)	EIRP (dBm)	EIRP (mW)	Limit (W)
20800	2505	22.38	2	24.38	274.16	2
21100	2535	22.28	2	24.28	267.92	2
21400	2565	22.44	2	24.44	277.97	2

CHANNEL BANDWIDTH: 15MHz QPSK

Channel	Frequency (MHz)	Conducted Power (dBm)	G _T -L _c (dB)	EIRP (dBm)	EIRP (mW)	Limit (W)
20825	2507.5	24.59	2	26.59	456.04	2
21100	2535.0	24.36	2	26.36	432.51	2
21375	2562.5	24.61	2	26.61	458.14	2

CHANNEL BANDWIDTH: 15MHz 16QAM

Channel	Frequency (MHz)	Conducted Power (dBm)	G _T -L _c (dB)	EIRP (dBm)	EIRP (mW)	Limit (W)
20825	2507.5	23.44	2	25.44	349.95	2
21100	2535.0	23.36	2	25.36	343.56	2
21375	2562.5	23.64	2	25.64	366.44	2

CHANNEL BANDWIDTH: 15MHz 64QAM

Channel	Frequency (MHz)	Conducted Power (dBm)	G _T -L _c (dB)	EIRP (dBm)	EIRP (mW)	Limit (W)
20825	2507.5	22.32	2	24.32	270.4	2
21100	2535	22.27	2	24.27	267.3	2
21375	2562.5	22.44	2	24.44	277.97	2



**BUREAU
VERITAS**

Test Report No.:W7L-P23080006RF06

CHANNEL BANDWIDTH: 20MHz QPSK

Channel	Frequency (MHz)	Conducted Power (dBm)	G _T -L _c (dB)	EIRP (dBm)	EIRP (mW)	Limit (W)
20850	2510.0	24.6	2	26.6	457.09	2
21100	2535.0	24.46	2	26.46	442.59	2
21350	2560.0	24.67	2	26.67	464.52	2

CHANNEL BANDWIDTH: 20MHz 16QAM

Channel	Frequency (MHz)	Conducted Power (dBm)	G _T -L _c (dB)	EIRP (dBm)	EIRP (mW)	Limit (W)
20850	2510.0	23.52	2	25.52	356.45	2
21100	2535.0	23.45	2	25.45	350.75	2
21350	2560.0	23.69	2	25.69	370.68	2

CHANNEL BANDWIDTH: 20MHz 64QAM

Channel	Frequency (MHz)	Conducted Power (dBm)	G _T -L _c (dB)	EIRP (dBm)	EIRP (mW)	Limit (W)
20850	2510	22.41	2	24.41	276.06	2
21100	2535	22.29	2	24.29	268.53	2
21350	2560	22.46	2	24.46	279.25	2

REMARKS: ERP Output Power (dBm) = EIRP (dBm) -2.15(dB).



**BUREAU
VERITAS**

Test Report No.:W7L-P23080006RF06

LTE BAND 13

CHANNEL BANDWIDTH: 5MHz QPSK

Channel	Frequency (MHz)	Conducted Power (dBm)	G _T -L _c (dB)	ERP (dBm)	ERP (mW)	Limit (W)
23205	779.5	24.2	-5.9	16.15	41.21	3
23230	782	24.26	-5.9	16.21	41.78	3
23255	784.5	24.22	-5.9	16.17	41.4	3

CHANNEL BANDWIDTH: 5MHz 16QAM

Channel	Frequency (MHz)	Conducted Power (dBm)	G _T -L _c (dB)	ERP (dBm)	ERP (mW)	Limit (W)
23205	779.5	23.17	-5.9	15.12	32.51	3
23230	782	23.2	-5.9	15.15	32.73	3
23255	784.5	23.27	-5.9	15.22	33.27	3

CHANNEL BANDWIDTH: 5MHz 64QAM

Channel	Frequency (MHz)	Conducted Power (dBm)	G _T -L _c (dB)	ERP (dBm)	ERP (mW)	Limit (W)
23205	779.5	22.13	-5.9	14.08	25.59	3
23230	782	22.16	-5.9	14.11	25.76	3
23255	784.5	22.09	-5.9	14.04	25.35	3



Test Report No.:W7L-P23080006RF06

CHANNEL BANDWIDTH: 10MHz QPSK

Channel	Frequency (MHz)	Conducted Power (dBm)	G _T -L _c (dB)	ERP (dBm)	ERP (mW)	Limit (W)
-	-	-	-	-	-	-
23230	782	24.28	-5.9	16.23	41.98	3
-	-	-	-	-	-	-

CHANNEL BANDWIDTH: 10MHz 16QAM

Channel	Frequency (MHz)	Conducted Power (dBm)	G _T -L _c (dB)	ERP (dBm)	ERP (mW)	Limit (W)
-	-	-	-	-	-	-
23230	782	23.28	-5.9	15.23	33.34	3
-	-	-	-	-	-	-

CHANNEL BANDWIDTH: 10MHz 64QAM

Channel	Frequency (MHz)	Conducted Power (dBm)	G _T -L _c (dB)	ERP (dBm)	ERP (mW)	Limit (W)
-	-	-	-	-	-	-
23230	782	22.19	-5.9	14.14	25.94	3
-	-	-	-	-	-	-

REMARKS: ERP Output Power (dBm) = EIRP (dBm) -2.15(dB).

3.2 FREQUENCY STABILITY MEASUREMENT

3.2.1 LIMITS OF FREQUENCY STABILITY MEASUREMENT

The frequency stability shall be sufficient to ensure that the fundamental emissions stay within the authorized bands of operation.

3.2.2 TEST PROCEDURE

- a. The device is placed at the oven room. The oven room could control the temperatures and humidity. Power warms up is at least 15 min and power applied should perform before recording frequency error.
- b. EUT is connected the external power supply to control the DC input power. The test voltage range is from minimum to maximum working voltage. Each step shall be recording the frequency error rate.
- c. The temperature range step is 10 degrees in this test items. All temperature levels shall be holding $\pm 0.5^{\circ}\text{C}$ during the measurement testing. Each temperature step shall be at least 0.5 hours, consider the EUT could be test under the stability condition.

NOTE: The frequency error was recorded frequency error from the communication simulator.

3.2.3 TEST SETUP

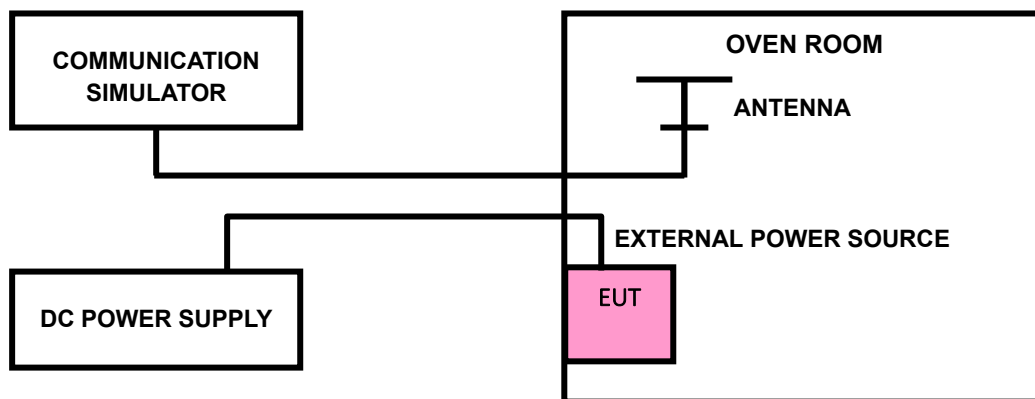



Test Report No.:W7L-P23080006RF06

3.2.4 TEST RESULTS

Please Refer to Appendix Of this test report.