

System Check_750MHz

DUT: D750V3-SN:1099

Communication System: UID 0, CW (0); Frequency: 750 MHz; Duty Cycle: 1:1

Medium: HSL_750_230513 Medium parameters used: $f = 750$ MHz; $\sigma = 0.888$ S/m; $\epsilon_r = 40.879$; $\rho = 1000$ kg/m³

Ambient Temperature : 23.3 °C; Liquid Temperature : 22.4 °C

DASY5 Configuration:

- Probe: ES3DV3 - SN3191; ConvF(6.52, 5.92, 6.43); Calibrated: 2023/2/17
- Sensor-Surface: 3mm (Mechanical Surface Detection)
- Electronics: DAE4 Sn1437; Calibrated: 2022/11/23
- Phantom: SAM (Front) with CRP v5.0; Type: QD000P40CD; Serial: TP:1795
- Measurement SW: DASY52, Version 52.10 (3); SEMCAD X Version 14.6.13 (7474)

Pin=250mW/Area Scan (61x61x1): Interpolated grid: dx=1.500 mm, dy=1.500 mm
Maximum value of SAR (interpolated) = 2.51 W/kg

Pin=250mW/Zoom Scan (5x5x7)/Cube 0: Measurement grid: dx=8mm, dy=8mm, dz=5mm

Reference Value = 54.56 V/m; Power Drift = 0.10 dB

Peak SAR (extrapolated) = 3.10 W/kg

SAR(1 g) = 2.17 W/kg; SAR(10 g) = 1.45 W/kg

Maximum value of SAR (measured) = 2.52 W/kg

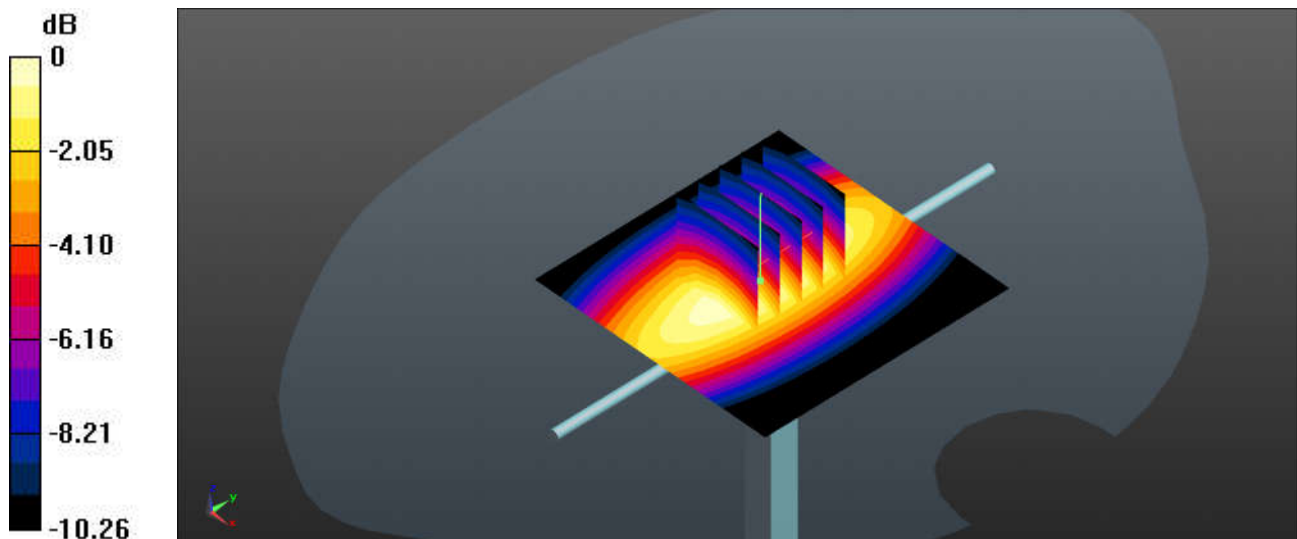

0 dB = 2.52 W/kg

System Check_750MHz

DUT: D750V3-SN:1099

Communication System: UID 0, CW (0); Frequency: 750 MHz; Duty Cycle: 1:1

Medium: HSL_750_230523 Medium parameters used: $f = 750 \text{ MHz}$; $\sigma = 0.878 \text{ S/m}$; $\epsilon_r = 40.673$; $\rho = 1000 \text{ kg/m}^3$

Ambient Temperature : 23.3 °C; Liquid Temperature : 22.6 °C

DASY5 Configuration:

- Probe: ES3DV3 - SN3191; ConvF(6.52, 5.92, 6.43); Calibrated: 2023/2/17
- Sensor-Surface: 3mm (Mechanical Surface Detection)
- Electronics: DAE4 Sn1437; Calibrated: 2022/11/23
- Phantom: SAM (Front) with CRP v5.0; Type: QD000P40CD; Serial: TP:1795
- Measurement SW: DASY52, Version 52.10 (3); SEMCAD X Version 14.6.13 (7474)

Pin=250mW/Area Scan (61x61x1): Interpolated grid: $dx=1.500 \text{ mm}$, $dy=1.500 \text{ mm}$
Maximum value of SAR (interpolated) = 2.39 W/kg

Pin=250mW/Zoom Scan (5x5x7)/Cube 0: Measurement grid: $dx=8\text{mm}$, $dy=8\text{mm}$, $dz=5\text{mm}$
Reference Value = 54.21 V/m; Power Drift = -0.01 dB
Peak SAR (extrapolated) = 2.92 W/kg
SAR(1 g) = 2.06 W/kg; SAR(10 g) = 1.37 W/kg
Maximum value of SAR (measured) = 2.38 W/kg

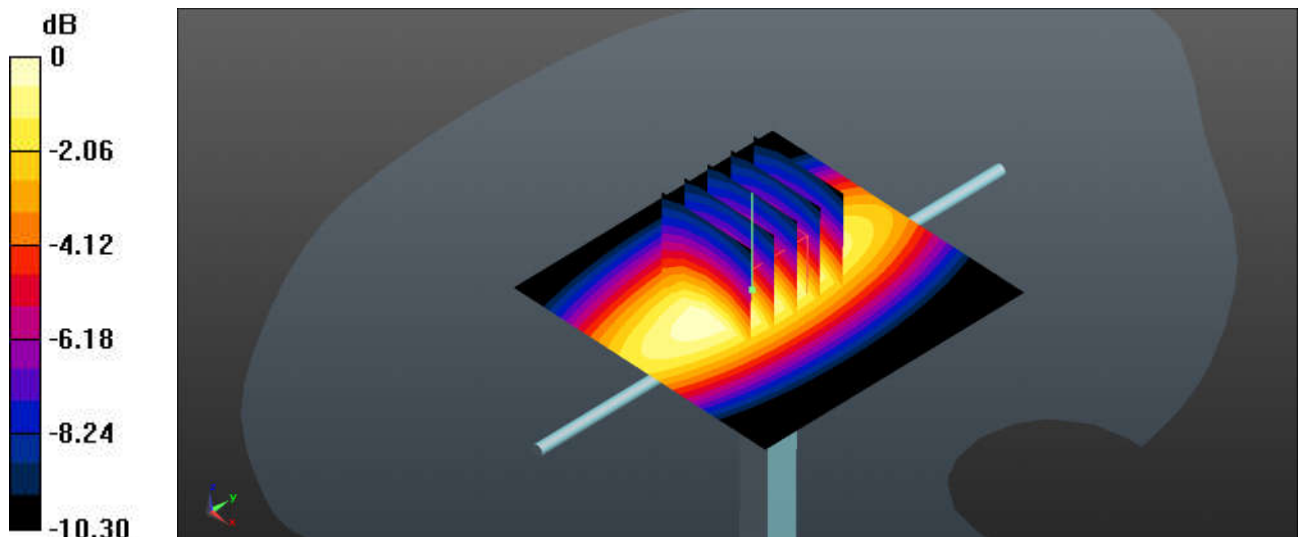

0 dB = 2.38 W/kg

System Check_835MHz

DUT: D835V2-SN:4d162

Communication System: UID 0, CW (0); Frequency: 835 MHz; Duty Cycle: 1:1

Medium: HSL_835_230514 Medium parameters used: $f = 835$ MHz; $\sigma = 0.911$ S/m; $\epsilon_r = 42.404$; $\rho = 1000$ kg/m³

Ambient Temperature : 23.2 °C; Liquid Temperature : 22.3 °C

DASY5 Configuration:

- Probe: ES3DV3 - SN3191; ConvF(6.58, 5.99, 6.22); Calibrated: 2023/2/17
- Sensor-Surface: 3mm (Mechanical Surface Detection)
- Electronics: DAE4 Sn1437; Calibrated: 2022/11/23
- Phantom: SAM (Front) with CRP v5.0; Type: QD000P40CD; Serial: TP:1795
- Measurement SW: DASY52, Version 52.10 (3); SEMCAD X Version 14.6.13 (7474)

Pin=250mW/Area Scan (61x61x1): Interpolated grid: dx=1.500 mm, dy=1.500 mm
Maximum value of SAR (interpolated) = 2.93 W/kg

Pin=250mW/Zoom Scan (5x5x7)/Cube 0: Measurement grid: dx=8mm, dy=8mm, dz=5mm
Reference Value = 58.22 V/m; Power Drift = 0.04 dB
Peak SAR (extrapolated) = 3.61 W/kg
SAR(1 g) = 2.52 W/kg; SAR(10 g) = 1.67 W/kg
Maximum value of SAR (measured) = 2.93 W/kg

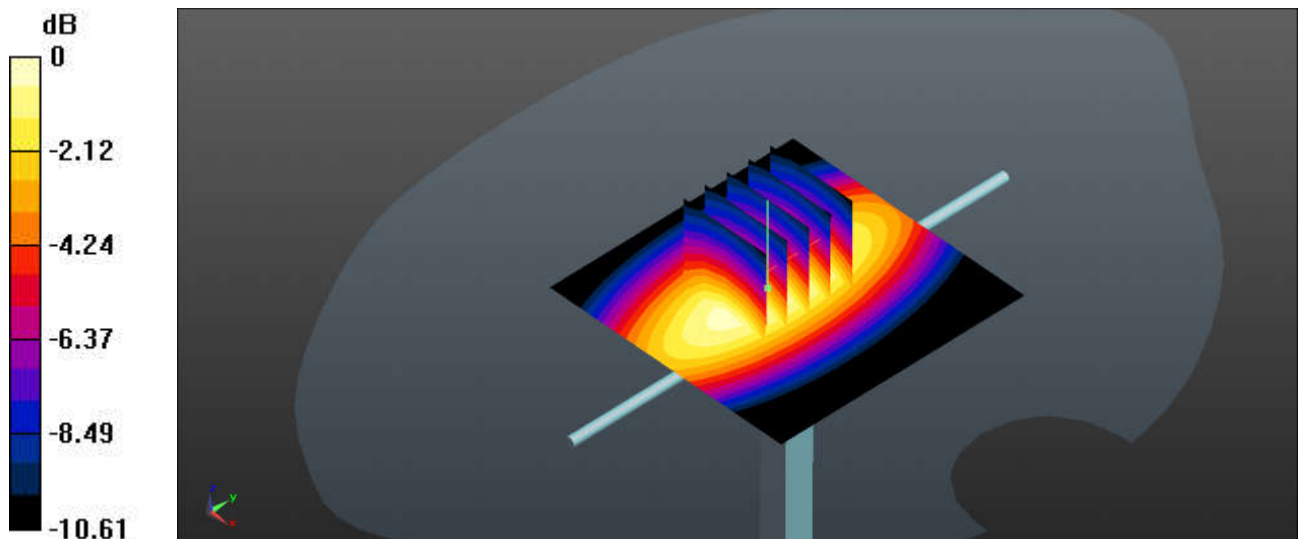

0 dB = 2.93 W/kg

System Check_835MHz

DUT: D835V2-SN:4d162

Communication System: UID 0, CW (0); Frequency: 835 MHz; Duty Cycle: 1:1

Medium: HSL_835_230524 Medium parameters used: $f = 835$ MHz; $\sigma = 0.908$ S/m; $\epsilon_r = 41.378$; $\rho = 1000$ kg/m³

Ambient Temperature : 23.3 °C; Liquid Temperature : 22.4 °C

DASY5 Configuration:

- Probe: ES3DV3 - SN3191; ConvF(6.58, 5.99, 6.22); Calibrated: 2023/2/17
- Sensor-Surface: 3mm (Mechanical Surface Detection)
- Electronics: DAE4 Sn1437; Calibrated: 2022/11/23
- Phantom: SAM (Front) with CRP v5.0; Type: QD000P40CD; Serial: TP:1795
- Measurement SW: DASY52, Version 52.10 (3); SEMCAD X Version 14.6.13 (7474)

Pin=250mW/Area Scan (61x61x1): Interpolated grid: dx=1.500 mm, dy=1.500 mm
Maximum value of SAR (interpolated) = 2.78 W/kg

Pin=250mW/Zoom Scan (5x5x7)/Cube 0: Measurement grid: dx=8mm, dy=8mm, dz=5mm
Reference Value = 56.60 V/m; Power Drift = 0.09 dB
Peak SAR (extrapolated) = 3.44 W/kg
SAR(1 g) = 2.39 W/kg; SAR(10 g) = 1.57 W/kg
Maximum value of SAR (measured) = 2.79 W/kg

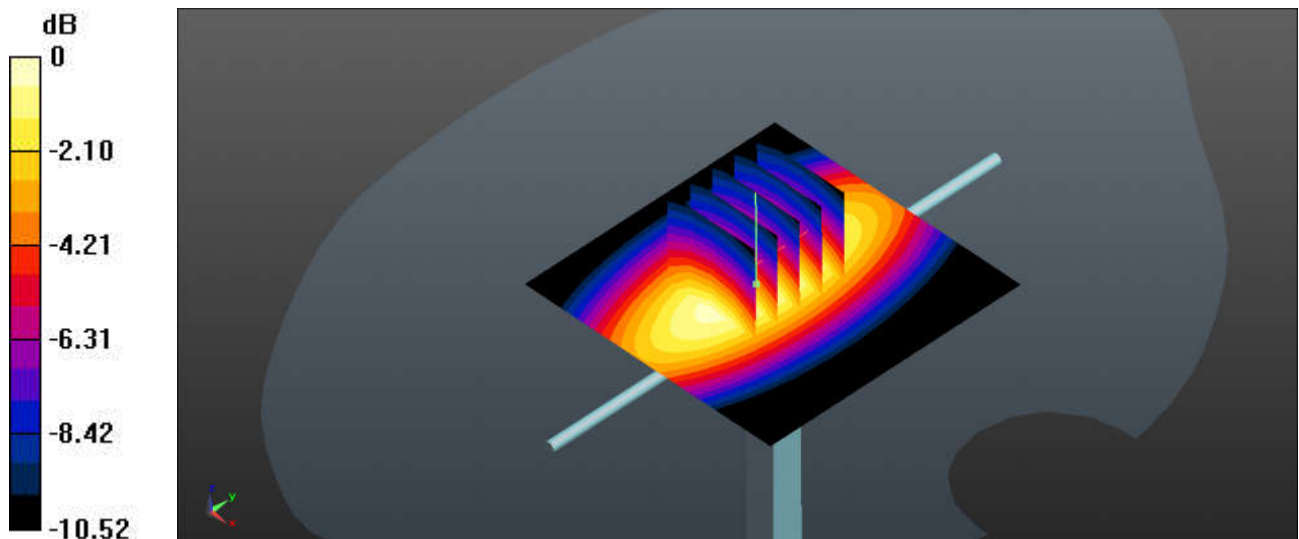

0 dB = 2.79 W/kg

System Check_1750MHz

DUT: D1750V2-SN:1137

Communication System: UID 0, CW; Frequency: 1750 MHz; Duty Cycle: 1:1

Medium: HSL_1750_230515 Medium parameters used: $f = 1750$ MHz; $\sigma = 1.383$ S/m; $\epsilon_r = 41.3$; $\rho = 1000$ kg/m³

Ambient Temperature : 23.3 °C; Liquid Temperature : 22.3 °C

DASY5 Configuration:

- Probe: ES3DV3 - SN3191; ConvF(5.68, 5.08, 5.5); Calibrated: 2023/2/17
- Sensor-Surface: 3mm (Mechanical Surface Detection)
- Electronics: DAE4 Sn1437; Calibrated: 2022/11/23
- Phantom: SAM (Front) with CRP v5.0; Type: QD000P40CD; Serial: TP:1795
- Measurement SW: DASY52, Version 52.10 (3); SEMCAD X Version 14.6.13 (7474)

Pin=250mW/Area Scan (61x71x1): Interpolated grid: dx=1.500 mm, dy=1.500 mm
Maximum value of SAR (interpolated) = 12.5 W/kg

Pin=250mW/Zoom Scan (5x5x7)/Cube 0: Measurement grid: dx=8mm, dy=8mm, dz=5mm
Reference Value = 92.68 V/m; Power Drift = 0.10 dB
Peak SAR (extrapolated) = 16.7 W/kg
SAR(1 g) = 9.41 W/kg; SAR(10 g) = 5.08 W/kg
Maximum value of SAR (measured) = 11.5 W/kg

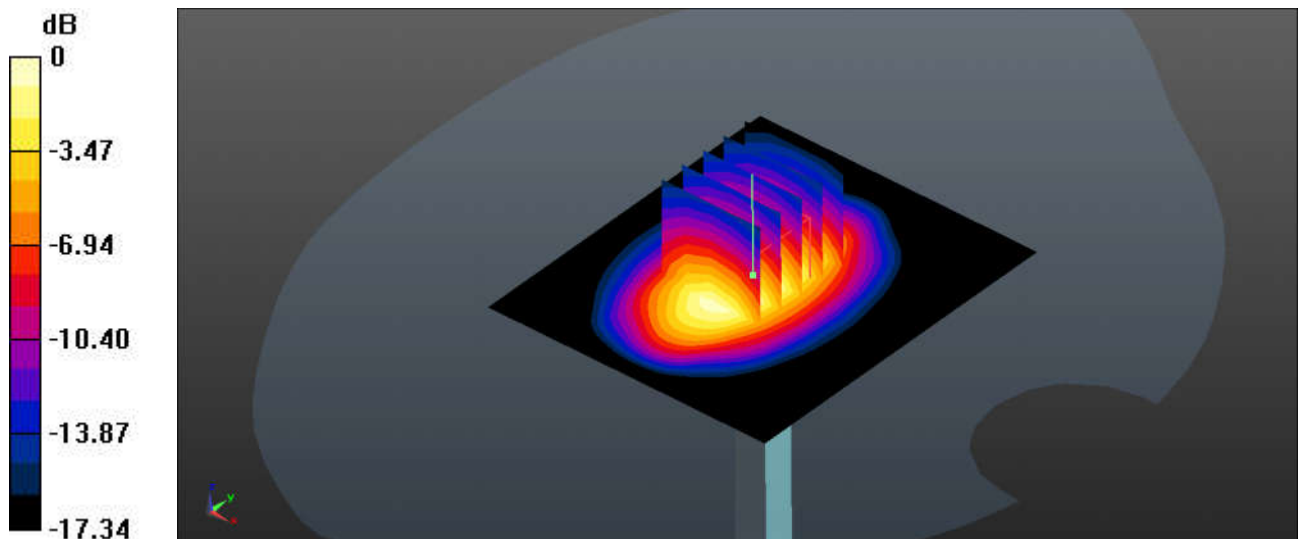

0 dB = 11.5 W/kg

System Check_1750MHz

DUT: D1750V2-SN:1137

Communication System: UID 0, CW; Frequency: 1750 MHz; Duty Cycle: 1:1

Medium: HSL_1750_230525 Medium parameters used: $f = 1750$ MHz; $\sigma = 1.362$ S/m; $\epsilon_r = 41.482$; $\rho = 1000$ kg/m³

Ambient Temperature : 23.6 °C; Liquid Temperature : 22.5 °C

DASY5 Configuration:

- Probe: ES3DV3 - SN3191; ConvF(5.68, 5.08, 5.5); Calibrated: 2023/2/17
- Sensor-Surface: 3mm (Mechanical Surface Detection)
- Electronics: DAE4 Sn1437; Calibrated: 2022/11/23
- Phantom: SAM (Front) with CRP v5.0; Type: QD000P40CD; Serial: TP:1795
- Measurement SW: DASY52, Version 52.10 (3); SEMCAD X Version 14.6.13 (7474)

Pin=250mW/Area Scan (61x61x1): Interpolated grid: dx=1.500 mm, dy=1.500 mm
Maximum value of SAR (interpolated) = 11.4 W/kg

Pin=250mW/Zoom Scan (5x5x7)/Cube 0: Measurement grid: dx=8mm, dy=8mm, dz=5mm
Reference Value = 88.84 V/m; Power Drift = 0.12 dB
Peak SAR (extrapolated) = 14.2 W/kg
SAR(1 g) = 9.13 W/kg; SAR(10 g) = 4.82 W/kg
Maximum value of SAR (measured) = 11.5 W/kg

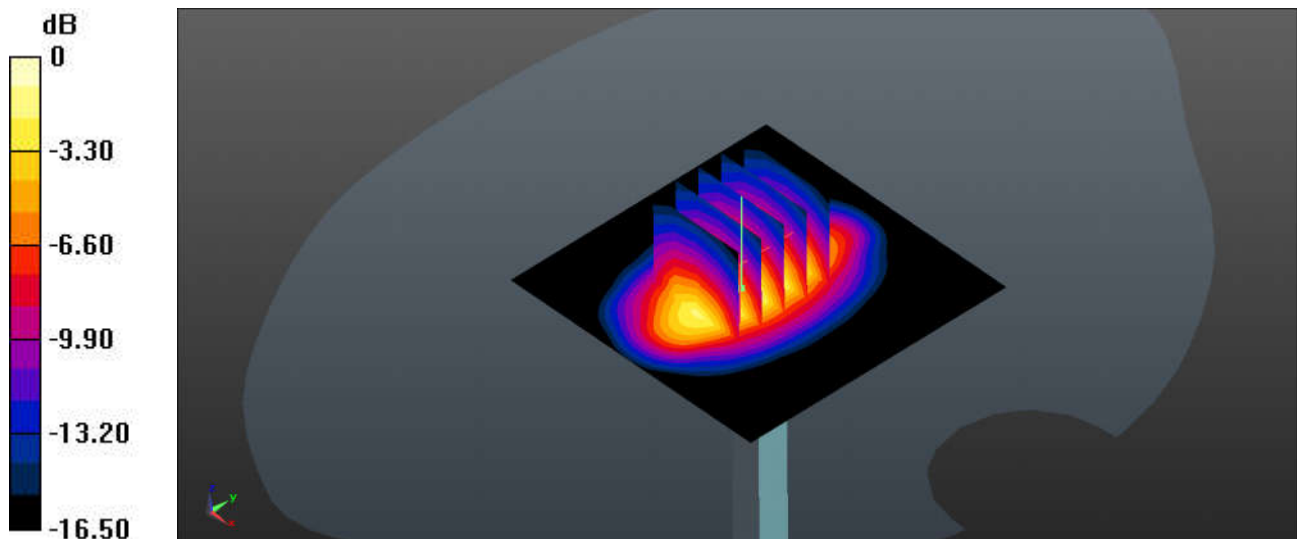

0 dB = 11.5 W/kg

System Check_1900MHz

DUT: D1900V2-SN:5d182

Communication System: UID 0, CW; Frequency: 1900 MHz; Duty Cycle: 1:1

Medium: HSL_1900_230516 Medium parameters used: $f = 1900$ MHz; $\sigma = 1.412$ S/m; $\epsilon_r = 38.427$; $\rho = 1000$ kg/m³

Ambient Temperature : 23.4 °C; Liquid Temperature : 22.3 °C

DASY5 Configuration:

- Probe: ES3DV3 - SN3191; ConvF(5.36, 4.85, 5.23); Calibrated: 2023/2/17
- Sensor-Surface: 3mm (Mechanical Surface Detection)
- Electronics: DAE4 Sn1437; Calibrated: 2022/11/23
- Phantom: SAM (Front) with CRP v5.0; Type: QD000P40CD; Serial: TP:1795
- Measurement SW: DASY52, Version 52.10 (3); SEMCAD X Version 14.6.13 (7474)

Pin=250mW/Area Scan (61x61x1): Interpolated grid: dx=1.500 mm, dy=1.500 mm
Maximum value of SAR (interpolated) = 13.3 W/kg

Pin=250mW/Zoom Scan (5x5x7)/Cube 0: Measurement grid: dx=8mm, dy=8mm, dz=5mm

Reference Value = 97.39 V/m; Power Drift = 0.09 dB

Peak SAR (extrapolated) = 18.3 W/kg

SAR(1 g) = 10.3 W/kg; SAR(10 g) = 5.41 W/kg

Maximum value of SAR (measured) = 12.9 W/kg

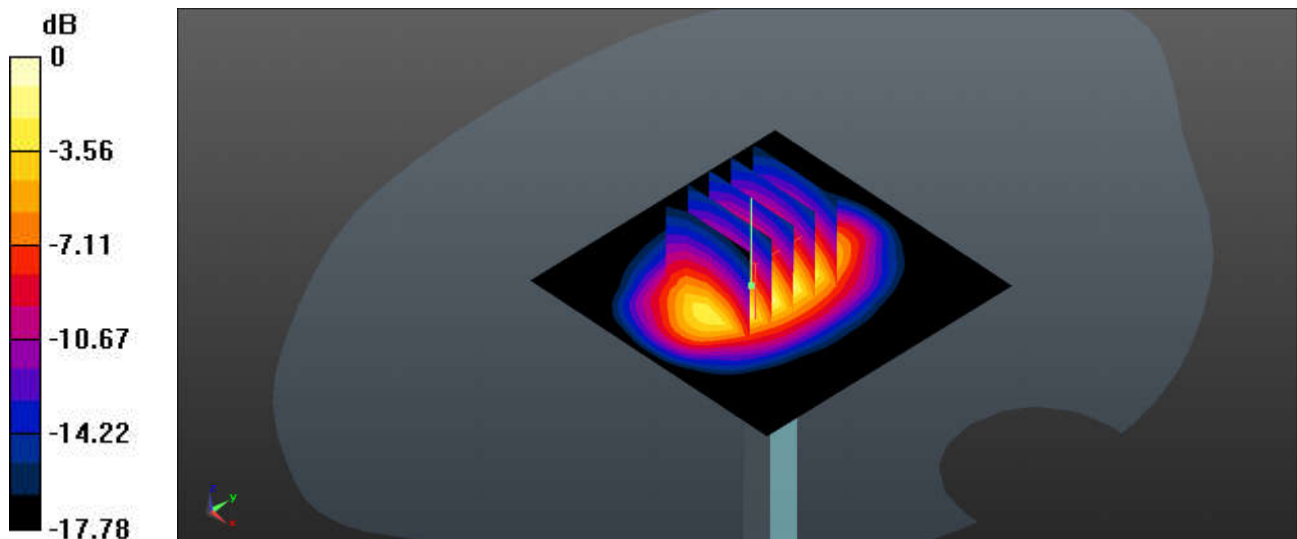

0 dB = 12.9 W/kg

System Check_1900MHz

DUT: D1900V2-SN:5d182

Communication System: UID 0, CW; Frequency: 1900 MHz; Duty Cycle: 1:1

Medium: HSL_1900_230526 Medium parameters used: $f = 1900$ MHz; $\sigma = 1.428$ S/m; $\epsilon_r = 41.216$; $\rho = 1000$ kg/m³

Ambient Temperature : 23.2 °C; Liquid Temperature : 22.4 °C

DASY5 Configuration:

- Probe: ES3DV3 - SN3191; ConvF(5.36, 4.85, 5.23); Calibrated: 2023/2/17
- Sensor-Surface: 3mm (Mechanical Surface Detection)
- Electronics: DAE4 Sn1437; Calibrated: 2022/11/23
- Phantom: SAM (Front) with CRP v5.0; Type: QD000P40CD; Serial: TP:1795
- Measurement SW: DASY52, Version 52.10 (3); SEMCAD X Version 14.6.13 (7474)

Pin=250mW/Area Scan (61x61x1): Interpolated grid: dx=1.500 mm, dy=1.500 mm
Maximum value of SAR (interpolated) = 12.5 W/kg

Pin=250mW/Zoom Scan (5x5x7)/Cube 0: Measurement grid: dx=8mm, dy=8mm, dz=5mm
Reference Value = 92.24 V/m; Power Drift = 0.11 dB
Peak SAR (extrapolated) = 17.5 W/kg
SAR(1 g) = 9.68 W/kg; SAR(10 g) = 5.03 W/kg
Maximum value of SAR (measured) = 12.2 W/kg

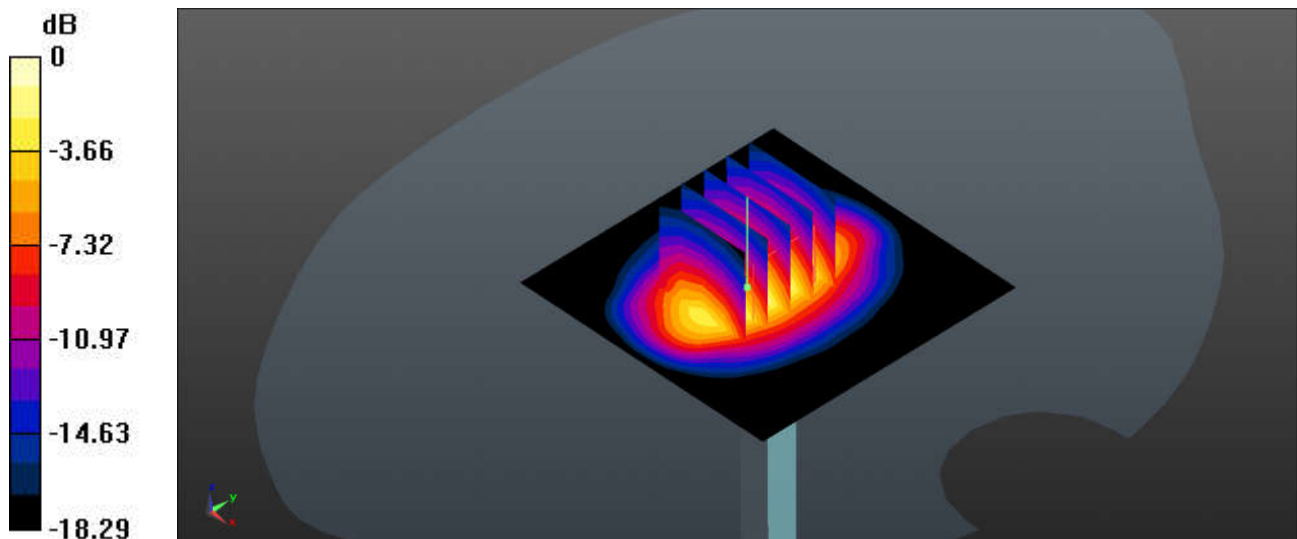

0 dB = 12.2 W/kg

System Check_2450MHz

DUT: D2450V2-SN:924

Communication System: UID 0, CW; Frequency: 2450 MHz; Duty Cycle: 1:1

Medium: HSL_2450_230520 Medium parameters used: $f = 2450$ MHz; $\sigma = 1.823$ S/m; $\epsilon_r = 37.961$; $\rho = 1000$ kg/m³

Ambient Temperature : 23.3 °C; Liquid Temperature : 22.5 °C

DASY5 Configuration:

- Probe: ES3DV3 - SN3191; ConvF(4.89, 4.46, 4.77); Calibrated: 2023/2/17
- Sensor-Surface: 3mm (Mechanical Surface Detection)
- Electronics: DAE4 Sn1437; Calibrated: 2022/11/23
- Phantom: SAM (Front) with CRP v5.0; Type: QD000P40CD; Serial: TP:1795
- Measurement SW: DASY52, Version 52.10 (3); SEMCAD X Version 14.6.13 (7474)

Pin=250mW/Area Scan (81x81x1): Interpolated grid: dx=1.200 mm, dy=1.200 mm
Maximum value of SAR (interpolated) = 16.8 W/kg

Pin=250mW/Zoom Scan (7x7x7)/Cube 0: Measurement grid: dx=5mm, dy=5mm, dz=5mm
Reference Value = 95.08 V/m; Power Drift = 0.18 dB
Peak SAR (extrapolated) = 26.5 W/kg
SAR(1 g) = 12.7 W/kg; SAR(10 g) = 5.87 W/kg
Maximum value of SAR (measured) = 16.7 W/kg

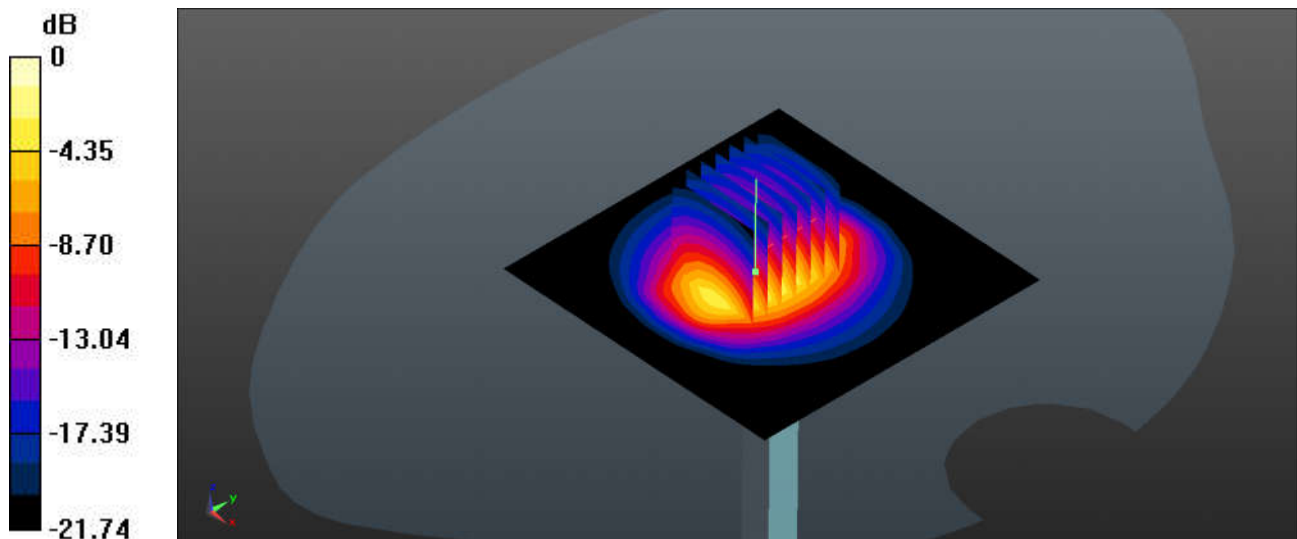

0 dB = 16.7 W/kg

System Check_2450MHz

DUT: D2450V2-SN:924

Communication System: UID 0, CW; Frequency: 2450 MHz; Duty Cycle: 1:1

Medium: HSL_2450_230527 Medium parameters used: $f = 2450$ MHz; $\sigma = 1.804$ S/m; $\epsilon_r = 37.483$; $\rho = 1000$ kg/m³

Ambient Temperature : 23.3 °C; Liquid Temperature : 22.3 °C

DASY5 Configuration:

- Probe: ES3DV3 - SN3191; ConvF(4.89, 4.46, 4.77); Calibrated: 2023/2/17
- Sensor-Surface: 3mm (Mechanical Surface Detection)
- Electronics: DAE4 Sn1437; Calibrated: 2022/11/23
- Phantom: SAM (Front) with CRP v5.0; Type: QD000P40CD; Serial: TP:1795
- Measurement SW: DASY52, Version 52.10 (3); SEMCAD X Version 14.6.13 (7474)

Pin=250mW/Area Scan (81x81x1): Interpolated grid: dx=1.200 mm, dy=1.200 mm
Maximum value of SAR (interpolated) = 21.3 W/kg

Pin=250mW/Zoom Scan (7x7x7)/Cube 0: Measurement grid: dx=5mm, dy=5mm, dz=5mm

Reference Value = 88.31 V/m; Power Drift = 0.01 dB

Peak SAR (extrapolated) = 30.2 W/kg

SAR(1 g) = 13.7 W/kg; SAR(10 g) = 6.14 W/kg

Maximum value of SAR (measured) = 21.6 W/kg

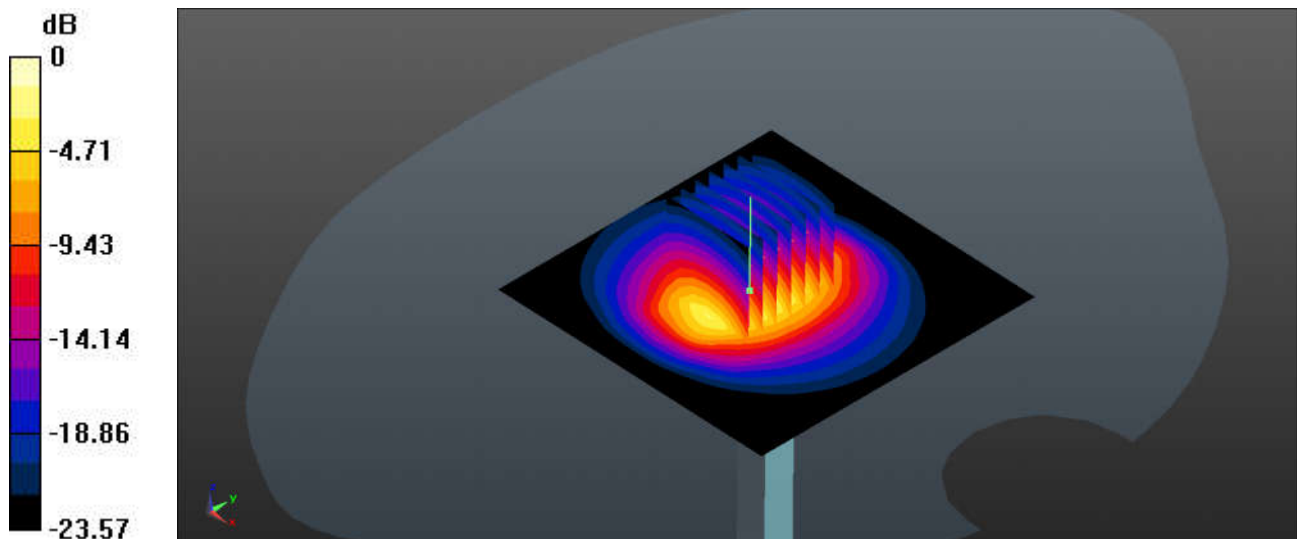

0 dB = 21.6 W/kg

System Check_2600MHz

DUT: D2600V2-SN:1070

Communication System: UID 0, CW (0); Frequency: 2600 MHz; Duty Cycle: 1:1

Medium: HSL_2600_230516 Medium parameters used: $f = 2600$ MHz; $\sigma = 1.934$ S/m; $\epsilon_r = 37.621$; $\rho = 1000$ kg/m³

Ambient Temperature : 23.5 °C; Liquid Temperature : 22.4 °C

DASY5 Configuration:

- Probe: ES3DV3 - SN3191; ConvF(4.83, 4.44, 4.75); Calibrated: 2023/2/17
- Sensor-Surface: 3mm (Mechanical Surface Detection)
- Electronics: DAE4 Sn1437; Calibrated: 2022/11/23
- Phantom: SAM (Front) with CRP v5.0; Type: QD000P40CD; Serial: TP:1795
- Measurement SW: DASY52, Version 52.10 (3); SEMCAD X Version 14.6.13 (7474)

Pin=250mW/Area Scan (71x81x1): Interpolated grid: dx=1.200 mm, dy=1.200 mm
Maximum value of SAR (interpolated) = 18.2 W/kg

Pin=250mW/Zoom Scan (7x7x7)/Cube 0: Measurement grid: dx=5mm, dy=5mm, dz=5mm
Reference Value = 98.95 V/m; Power Drift = -0.16 dB
Peak SAR (extrapolated) = 28.7 W/kg
SAR(1 g) = 13 W/kg; SAR(10 g) = 5.79 W/kg
Maximum value of SAR (measured) = 17.4 W/kg

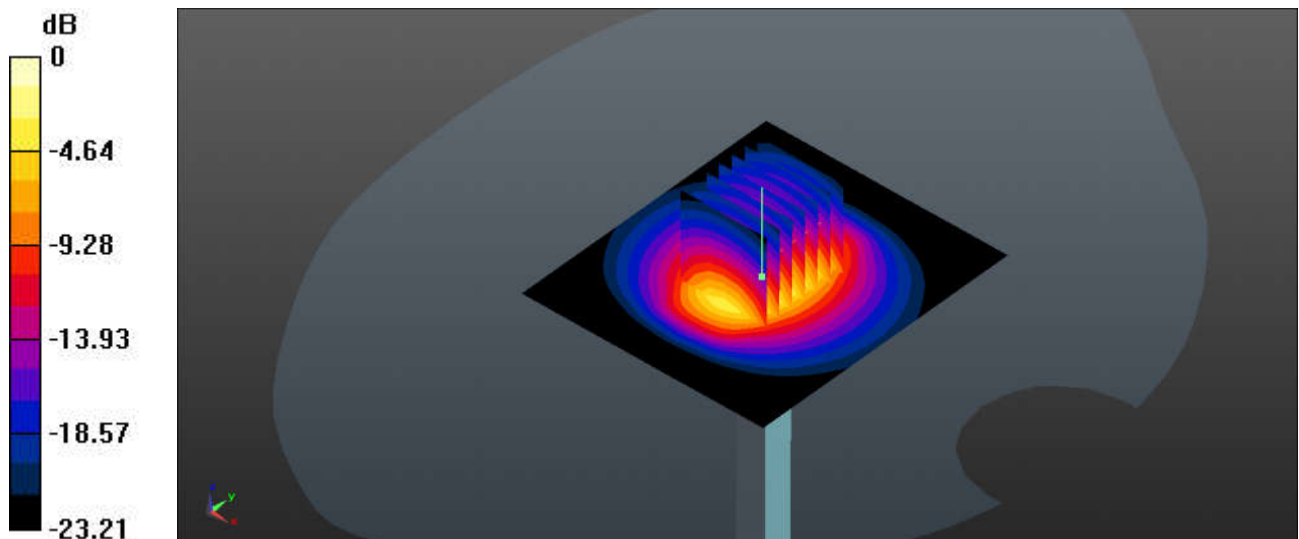

0 dB = 17.4 W/kg

System Check_2600MHz

DUT: D2600V2-SN:1070

Communication System: UID 0, CW (0); Frequency: 2600 MHz; Duty Cycle: 1:1

Medium: HSL_2600_230528 Medium parameters used: $f = 2600$ MHz; $\sigma = 1.915$ S/m; $\epsilon_r = 39.536$; $\rho = 1000$ kg/m³

Ambient Temperature : 23.5 °C; Liquid Temperature : 22.2 °C

DASY5 Configuration:

- Probe: ES3DV3 - SN3191; ConvF(4.83, 4.44, 4.75); Calibrated: 2023/2/17
- Sensor-Surface: 3mm (Mechanical Surface Detection)
- Electronics: DAE4 Sn1437; Calibrated: 2022/11/23
- Phantom: SAM (Front) with CRP v5.0; Type: QD000P40CD; Serial: TP:1795
- Measurement SW: DASY52, Version 52.10 (3); SEMCAD X Version 14.6.13 (7474)

Pin=250mW/Area Scan (71x71x1): Interpolated grid: dx=1.200 mm, dy=1.200 mm
Maximum value of SAR (interpolated) = 23.0 W/kg

Pin=250mW/Zoom Scan (7x7x7)/Cube 0: Measurement grid: dx=5mm, dy=5mm, dz=5mm

Reference Value = 104.1 V/m; Power Drift = 0.10 dB

Peak SAR (extrapolated) = 32.7 W/kg

SAR(1 g) = 14.1 W/kg; SAR(10 g) = 6.09 W/kg

Maximum value of SAR (measured) = 22.7 W/kg

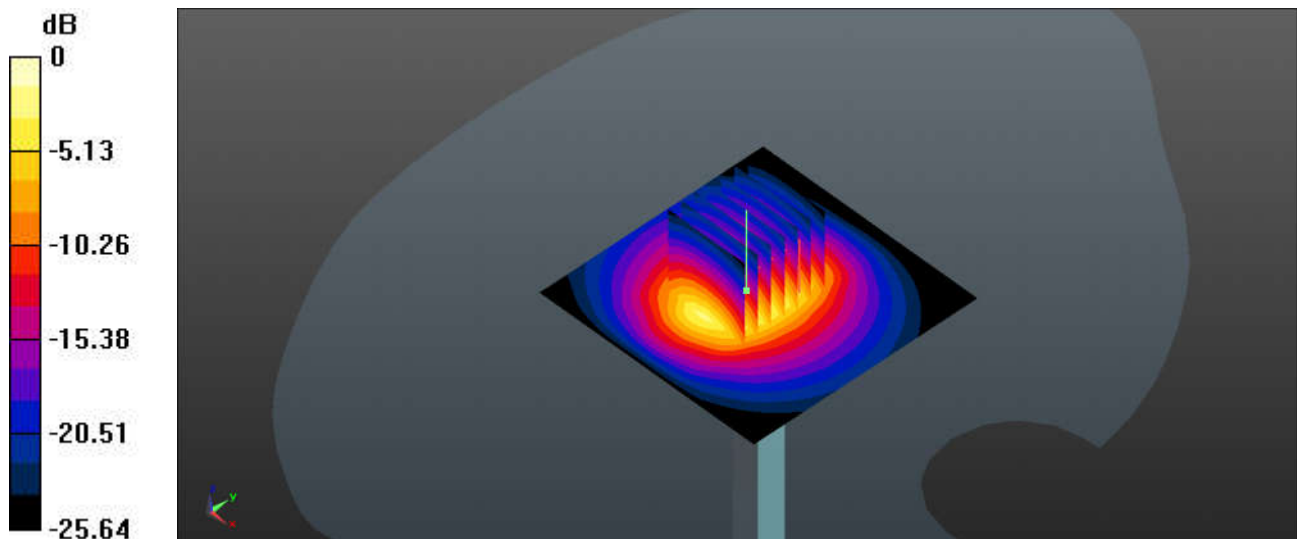

0 dB = 22.7 W/kg

System Check_3500MHz

DUT: D3500V2-SN:1037

Communication System: UID 0, CW (0); Frequency: 3500 MHz; Duty Cycle: 1:1

Medium: HSL_3500_230517 Medium parameters used: $f = 3500$ MHz; $\sigma = 2.933$ S/m; $\epsilon_r = 39.225$; $\rho = 1000$ kg/m³

Ambient Temperature : 23.3 °C; Liquid Temperature : 22.6 °C

DASY5 Configuration:

- Probe: EX3DV4 - SN3887; ConvF(6.57, 6.57, 6.57); Calibrated: 2022/10/28
- Sensor-Surface: 1.4mm (Mechanical Surface Detection)
- Electronics: DAE4 Sn679; Calibrated: 2022/6/6
- Phantom: SAM (Front) with CRP v5.0; Type: QD000P40CD; Serial: TP:1795
- Measurement SW: DASY52, Version 52.10 (3); SEMCAD X Version 14.6.13 (7474)

Pin=100mW/Area Scan (61x61x1): Interpolated grid: dx=1.200 mm, dy=1.200 mm

Maximum value of SAR (interpolated) = 13.0 W/kg

Pin=100mW/Zoom Scan (7x7x7)/Cube 0: Measurement grid: dx=5mm, dy=5mm, dz=1.4mm

Reference Value = 68.34 V/m; Power Drift = 0.17 dB

Peak SAR (extrapolated) = 18.3 W/kg

SAR(1 g) = 6.7 W/kg; SAR(10 g) = 2.53 W/kg

Maximum value of SAR (measured) = 13.3 W/kg

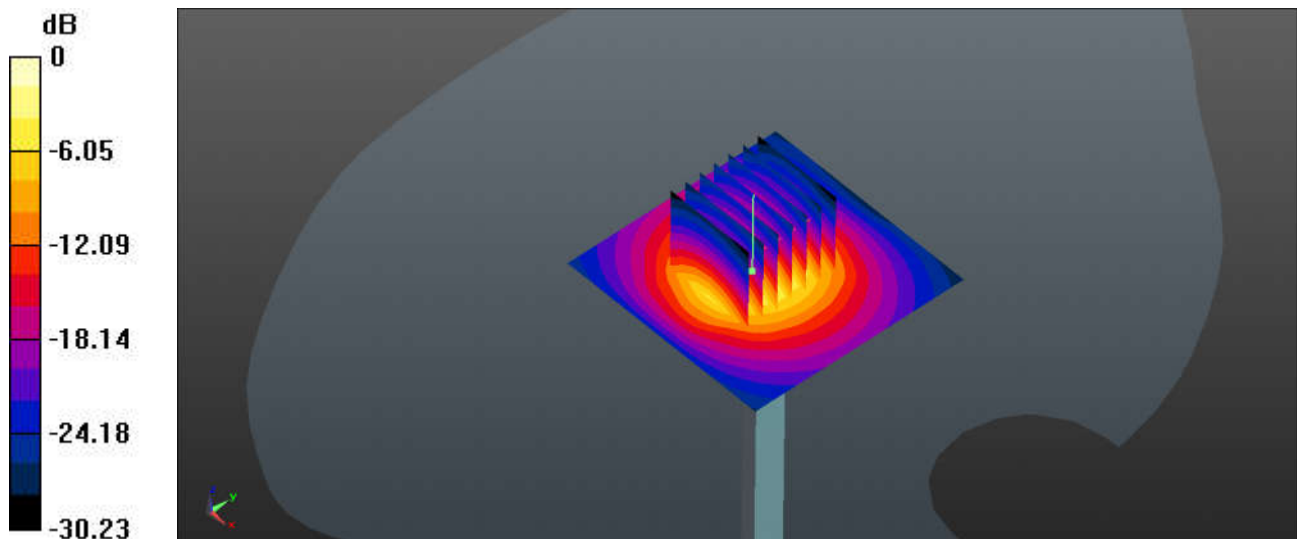

0 dB = 13.3 W/kg

System Check_3500MHz

DUT: D3500V2-SN:1037

Communication System: UID 0, CW (0); Frequency: 3500 MHz; Duty Cycle: 1:1

Medium: HSL_3500_230529 Medium parameters used: $f = 3500$ MHz; $\sigma = 2.935$ S/m; $\epsilon_r = 39.303$; $\rho = 1000$ kg/m³

Ambient Temperature : 23.5 °C; Liquid Temperature : 22.3 °C

DASY5 Configuration:

- Probe: EX3DV4 - SN3887; ConvF(6.57, 6.57, 6.57); Calibrated: 2022/10/28
- Sensor-Surface: 1.4mm (Mechanical Surface Detection)
- Electronics: DAE4 Sn679; Calibrated: 2022/6/6
- Phantom: SAM (Front) with CRP v5.0; Type: QD000P40CD; Serial: TP:1795
- Measurement SW: DASY52, Version 52.10 (3); SEMCAD X Version 14.6.13 (7474)

Pin=100mW/Area Scan (61x61x1): Interpolated grid: dx=1.200 mm, dy=1.200 mm
Maximum value of SAR (interpolated) = 15.0 W/kg

Pin=100mW/Zoom Scan (7x7x7)/Cube 0: Measurement grid: dx=5mm, dy=5mm, dz=1.4mm
Reference Value = 69.40 V/m; Power Drift = 0.10 dB
Peak SAR (extrapolated) = 19.9 W/kg
SAR(1 g) = 7.19 W/kg; SAR(10 g) = 2.71 W/kg
Maximum value of SAR (measured) = 14.9 W/kg

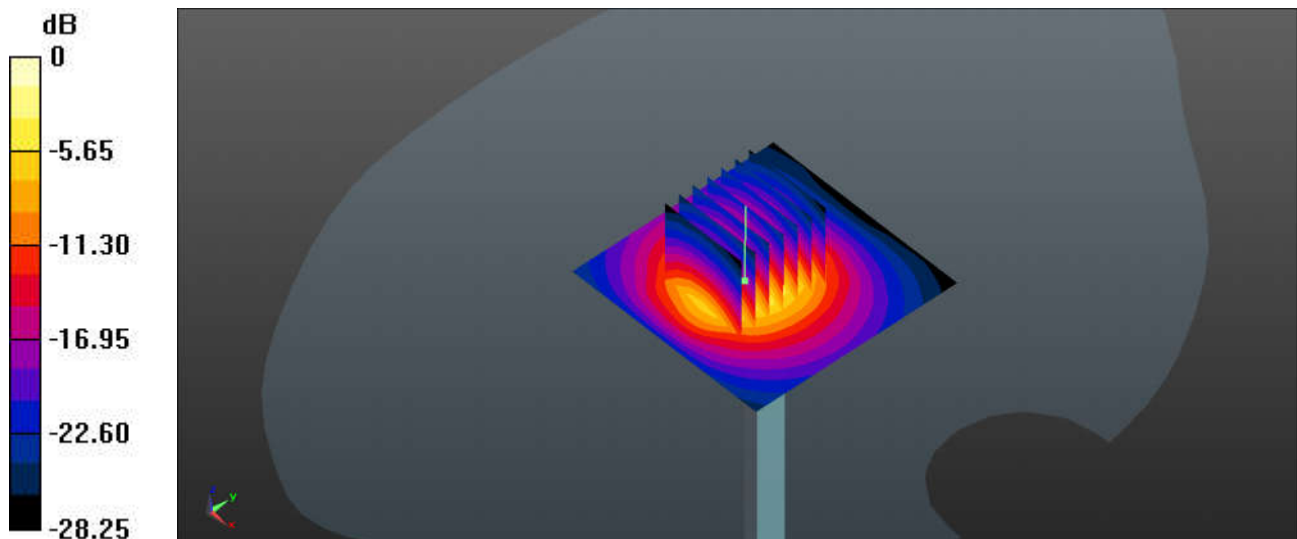

0 dB = 14.9 W/kg

System Check_3700MHz

DUT: D3700V2-SN:1008

Communication System: UID 0, CW (0); Frequency: 3700 MHz; Duty Cycle: 1:1

Medium: HSL_3700_230518 Medium parameters used: $f = 3700$ MHz; $\sigma = 3.031$ S/m; $\epsilon_r = 39.117$; $\rho = 1000$ kg/m³

Ambient Temperature : 23.3°C; Liquid Temperature : 22.2 °C

DASY5 Configuration:

- Probe: EX3DV4 - SN3887; ConvF(6.35, 6.35, 6.35); Calibrated: 2022/10/28
- Sensor-Surface: 1.4mm (Mechanical Surface Detection)
- Electronics: DAE4 Sn679; Calibrated: 2022/6/6
- Phantom: SAM (Front) with CRP v5.0; Type: QD000P40CD; Serial: TP:1795
- Measurement SW: DASY52, Version 52.10 (3); SEMCAD X Version 14.6.13 (7474)

Pin=100mW/Area Scan (61x61x1): Interpolated grid: dx=1.200 mm, dy=1.200 mm
Maximum value of SAR (interpolated) = 13.5 W/kg

Pin=100mW/Zoom Scan (7x7x7)/Cube 0: Measurement grid: dx=5mm, dy=5mm, dz=1.4mm
Reference Value = 69.82 V/m; Power Drift = -0.08 dB
Peak SAR (extrapolated) = 18.4 W/kg
SAR(1 g) = 6.53 W/kg; SAR(10 g) = 2.39 W/kg
Maximum value of SAR (measured) = 13.3 W/kg

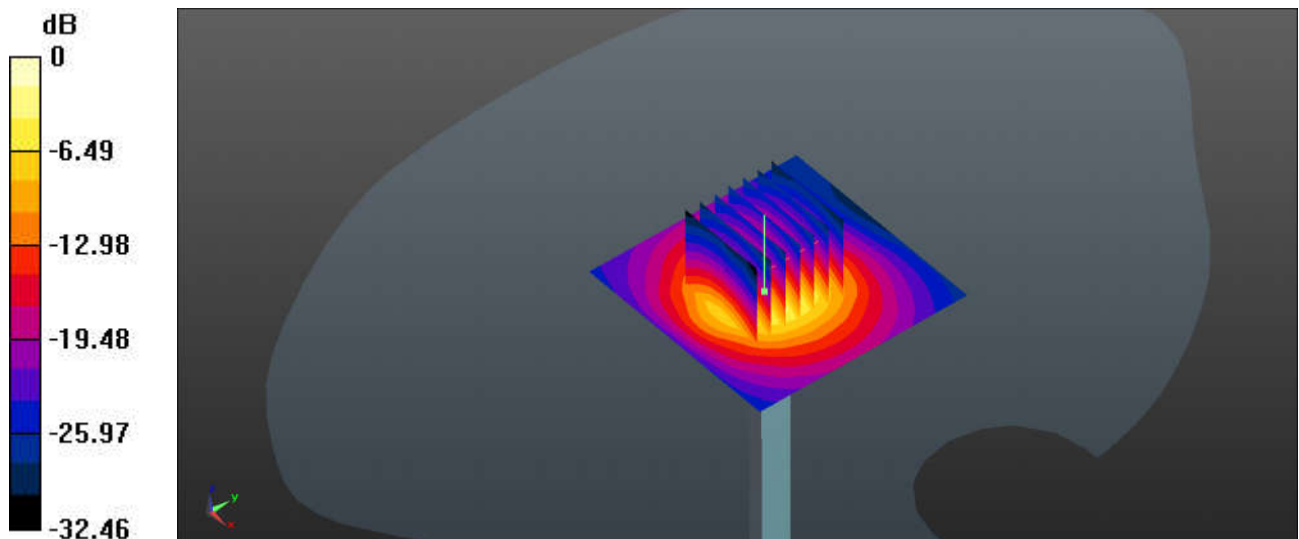

0 dB = 13.3 W/kg

System Check_3700MHz

DUT: D3700V2-SN:1008

Communication System: UID 0, CW (0); Frequency: 3700 MHz; Duty Cycle: 1:1

Medium: HSL_3700_230530 Medium parameters used: $f = 3700$ MHz; $\sigma = 3.041$ S/m; $\epsilon_r = 36.377$; $\rho = 1000$ kg/m³

Ambient Temperature : 23.4°C; Liquid Temperature : 22.7 °C

DASY5 Configuration:

- Probe: EX3DV4 - SN3887; ConvF(6.35, 6.35, 6.35); Calibrated: 2022/10/28
- Sensor-Surface: 1.4mm (Mechanical Surface Detection)
- Electronics: DAE4 Sn679; Calibrated: 2022/6/6
- Phantom: SAM (Front) with CRP v5.0; Type: QD000P40CD; Serial: TP:1795
- Measurement SW: DASY52, Version 52.10 (3); SEMCAD X Version 14.6.13 (7474)

Pin=100mW/Area Scan (61x61x1): Interpolated grid: dx=1.200 mm, dy=1.200 mm
Maximum value of SAR (interpolated) = 15.3 W/kg

Pin=100mW/Zoom Scan (7x7x7)/Cube 0: Measurement grid: dx=5mm, dy=5mm, dz=1.4mm
Reference Value = 74.26 V/m; Power Drift = 0.00 dB
Peak SAR (extrapolated) = 20.9 W/kg
SAR(1 g) = 6.79 W/kg; SAR(10 g) = 2.52 W/kg
Maximum value of SAR (measured) = 15.4 W/kg

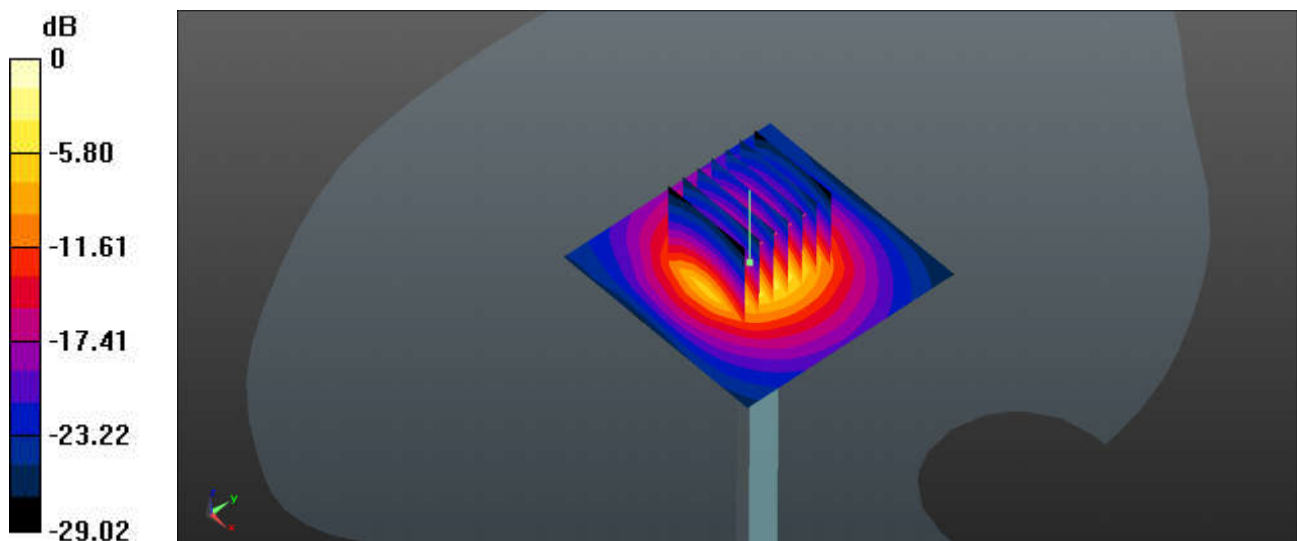

0 dB = 15.4 W/kg

System Check_3900MHz

DUT: D3900V2-SN:1022

Communication System: UID 0, CW (0); Frequency: 3900 MHz; Duty Cycle: 1:1

Medium: HSL_3900_230519 Medium parameters used: $f = 3900$ MHz; $\sigma = 3.214$ S/m; $\epsilon_r = 39.072$; $\rho = 1000$ kg/m³

Ambient Temperature : 23.6 °C; Liquid Temperature : 22.4 °C

DASY5 Configuration:

- Probe: EX3DV4 - SN3887; ConvF(6.13, 6.13, 6.13); Calibrated: 2022/10/28
- Sensor-Surface: 1.4mm (Mechanical Surface Detection)
- Electronics: DAE4 Sn679; Calibrated: 2022/6/6
- Phantom: SAM (Front) with CRP v5.0; Type: QD000P40CD; Serial: TP:1795
- Measurement SW: DASY52, Version 52.10 (3); SEMCAD X Version 14.6.13 (7474)

Pin=100mW/Area Scan (61x61x1): Interpolated grid: dx=1.200 mm, dy=1.200 mm
Maximum value of SAR (interpolated) = 12.5 W/kg

Pin=100mW/Zoom Scan (7x7x7)/Cube 0: Measurement grid: dx=5mm, dy=5mm, dz=1.4mm
Reference Value = 67.30 V/m; Power Drift = 0.02 dB
Peak SAR (extrapolated) = 17.2 W/kg
SAR(1 g) = 6.28 W/kg; SAR(10 g) = 2.24 W/kg
Maximum value of SAR (measured) = 12.5 W/kg

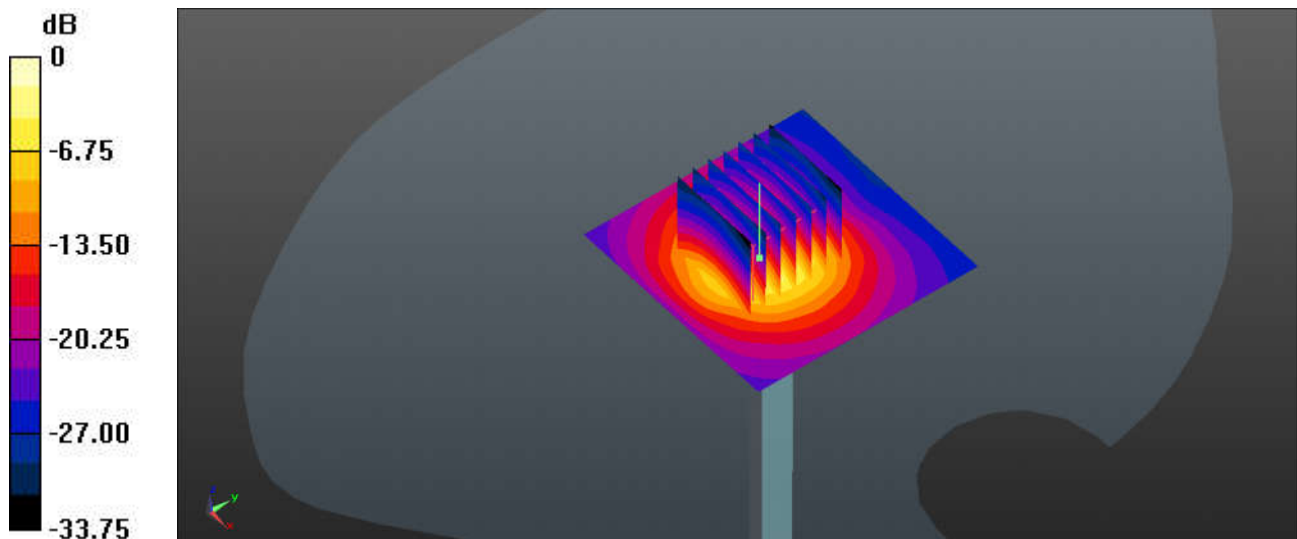

0 dB = 12.5 W/kg

System Check_3900MHz

DUT: D3900V2-SN:1022

Communication System: UID 0, CW (0); Frequency: 3900 MHz; Duty Cycle: 1:1

Medium: HSL_3900_230531 Medium parameters used: $f = 3900$ MHz; $\sigma = 3.199$ S/m; $\epsilon_r = 36.16$; $\rho = 1000$ kg/m³

Ambient Temperature : 23.6 °C; Liquid Temperature : 22.5 °C

DASY5 Configuration:

- Probe: EX3DV4 - SN3887; ConvF(6.13, 6.13, 6.13); Calibrated: 2022/10/28
- Sensor-Surface: 1.4mm (Mechanical Surface Detection)
- Electronics: DAE4 Sn679; Calibrated: 2022/6/6
- Phantom: SAM (Front) with CRP v5.0; Type: QD000P40CD; Serial: TP:1795
- Measurement SW: DASY52, Version 52.10 (3); SEMCAD X Version 14.6.13 (7474)

Pin=100mW/Area Scan (61x61x1): Interpolated grid: dx=1.200 mm, dy=1.200 mm

Maximum value of SAR (interpolated) = 15.1 W/kg

Pin=100mW/Zoom Scan (7x7x7)/Cube 0: Measurement grid: dx=5mm, dy=5mm, dz=1.4mm

Reference Value = 69.33 V/m; Power Drift = 0.12 dB

Peak SAR (extrapolated) = 21.2 W/kg

SAR(1 g) = 6.66 W/kg; SAR(10 g) = 2.33 W/kg

Maximum value of SAR (measured) = 15.5 W/kg

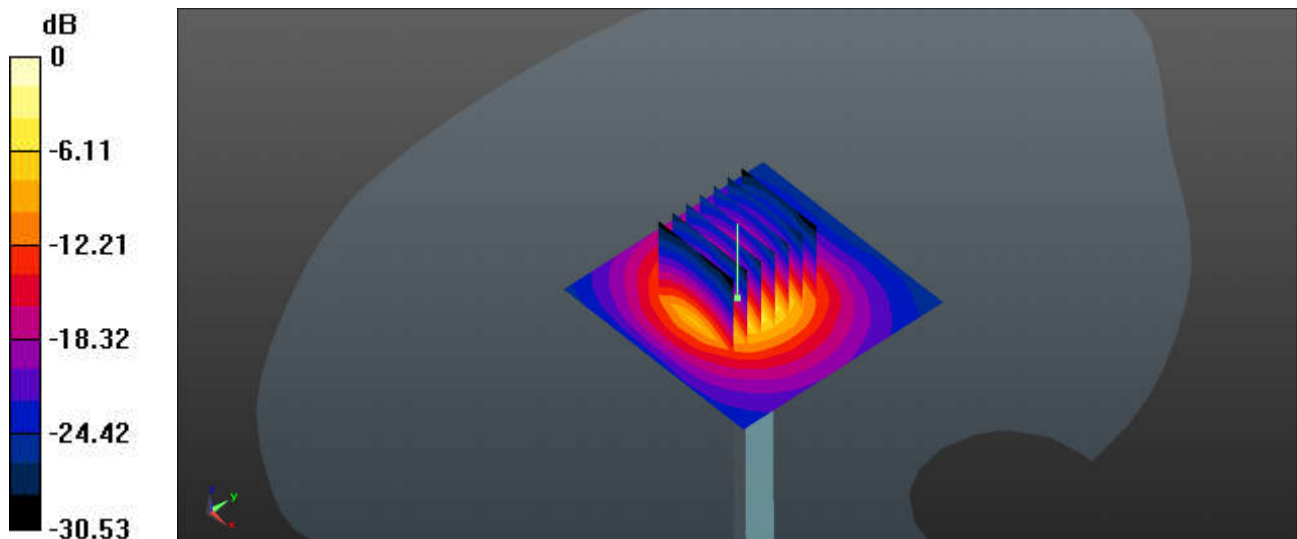

0 dB = 15.5 W/kg

System Check_5250MHz

DUT: D5GHzV2-SN:1341

Communication System: UID 0, CW; Frequency: 5250 MHz; Duty Cycle: 1:1

Medium: HSL_5250_230519 Medium parameters used: $f = 5250$ MHz; $\sigma = 4.841$ S/m; $\epsilon_r = 35.356$; $\rho = 1000$ kg/m³

Ambient Temperature : 23.4 °C; Liquid Temperature : 22.3 °C

DASY5 Configuration:

- Probe: EX3DV4 - SN3887; ConvF(4.8, 4.8, 4.8); Calibrated: 2022/10/28
- Sensor-Surface: 1.4mm (Mechanical Surface Detection)
- Electronics: DAE4 Sn679; Calibrated: 2022/6/6
- Phantom: SAM (Front) with CRP v5.0; Type: QD000P40CD; Serial: TP:1795
- Measurement SW: DASY52, Version 52.10 (3); SEMCAD X Version 14.6.13 (7474)

Pin=100mW/Area Scan (71x71x1): Interpolated grid: dx=1.000 mm, dy=1.000 mm
Maximum value of SAR (interpolated) = 20.4 W/kg

Pin=100mW/Zoom Scan (7x7x7)/Cube 0: Measurement grid: dx=4mm, dy=4mm, dz=1.4mm
Reference Value = 72.43 V/m; Power Drift = -0.01 dB
Peak SAR (extrapolated) = 33.1 W/kg
SAR(1 g) = 8.52 W/kg; SAR(10 g) = 2.4 W/kg
Maximum value of SAR (measured) = 20.5 W/kg

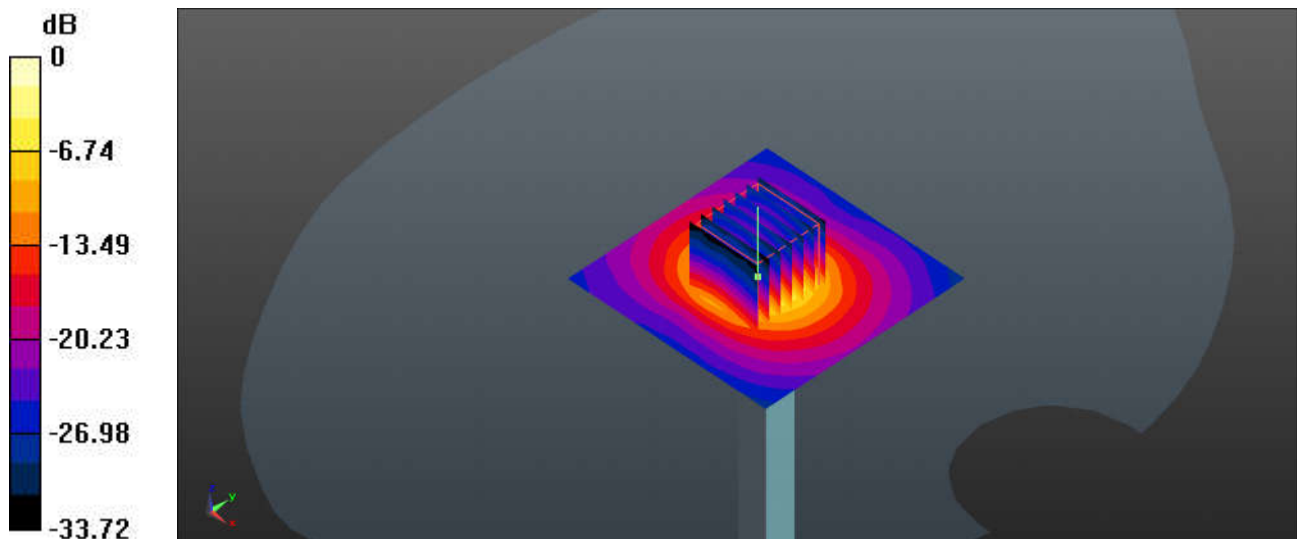

0 dB = 20.5 W/kg

System Check_5250MHz

DUT: D5GHzV2-SN:1341

Communication System: UID 0, CW; Frequency: 5250 MHz; Duty Cycle: 1:1

Medium: HSL_5250_230601 Medium parameters used: $f = 5250$ MHz; $\sigma = 4.554$ S/m; $\epsilon_r = 37.035$; $\rho = 1000$ kg/m³

Ambient Temperature : 23.2 °C; Liquid Temperature : 22.4 °C

DASY5 Configuration:

- Probe: EX3DV4 - SN3887; ConvF(4.8, 4.8, 4.8); Calibrated: 2022/10/28
- Sensor-Surface: 1.4mm (Mechanical Surface Detection)
- Electronics: DAE4 Sn679; Calibrated: 2022/6/6
- Phantom: SAM (Front) with CRP v5.0; Type: QD000P40CD; Serial: TP:1795
- Measurement SW: DASY52, Version 52.10 (3); SEMCAD X Version 14.6.13 (7474)

Pin=100mW/Area Scan (71x71x1): Interpolated grid: dx=1.000 mm, dy=1.000 mm
Maximum value of SAR (interpolated) = 20.4 W/kg

Pin=100mW/Zoom Scan (7x7x7)/Cube 0: Measurement grid: dx=4mm, dy=4mm, dz=1.4mm
Reference Value = 67.99 V/m; Power Drift = 0.17 dB
Peak SAR (extrapolated) = 33.9 W/kg
SAR(1 g) = 8.56 W/kg; SAR(10 g) = 2.41 W/kg
Maximum value of SAR (measured) = 20.7 W/kg

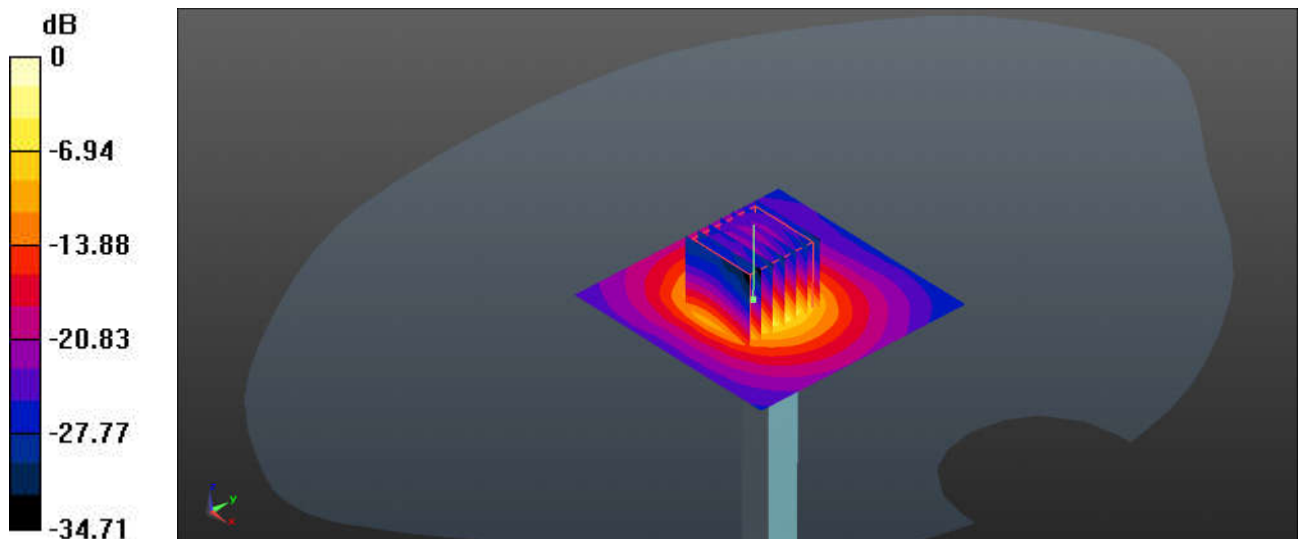

0 dB = 20.7 W/kg

System Check_5600MHz

DUT: D5GHzV2-SN:1341

Communication System: UID 0, CW; Frequency: 5600 MHz; Duty Cycle: 1:1

Medium: HSL_5600_230522 Medium parameters used: $f = 5600$ MHz; $\sigma = 5.002$ S/m; $\epsilon_r = 36.115$; $\rho = 1000$ kg/m³

Ambient Temperature : 23.5 °C; Liquid Temperature : 22.5 °C

DASY5 Configuration:

- Probe: EX3DV4 - SN3887; ConvF(4.19, 4.19, 4.19); Calibrated: 2022/10/28
- Sensor-Surface: 1.4mm (Mechanical Surface Detection)
- Electronics: DAE4 Sn679; Calibrated: 2022/6/6
- Phantom: SAM (Front) with CRP v5.0; Type: QD000P40CD; Serial: TP:1795
- Measurement SW: DASY52, Version 52.10 (3); SEMCAD X Version 14.6.13 (7474)

Pin=100mW/Area Scan (71x71x1): Interpolated grid: dx=1.000 mm, dy=1.000 mm
Maximum value of SAR (interpolated) = 22.7 W/kg

Pin=100mW/Zoom Scan (7x7x7)/Cube 0: Measurement grid: dx=4mm, dy=4mm, dz=1.4mm
Reference Value = 68.74 V/m; Power Drift = 0.07 dB
Peak SAR (extrapolated) = 37.3 W/kg
SAR(1 g) = 9.06 W/kg; SAR(10 g) = 2.55 W/kg
Maximum value of SAR (measured) = 22.3 W/kg

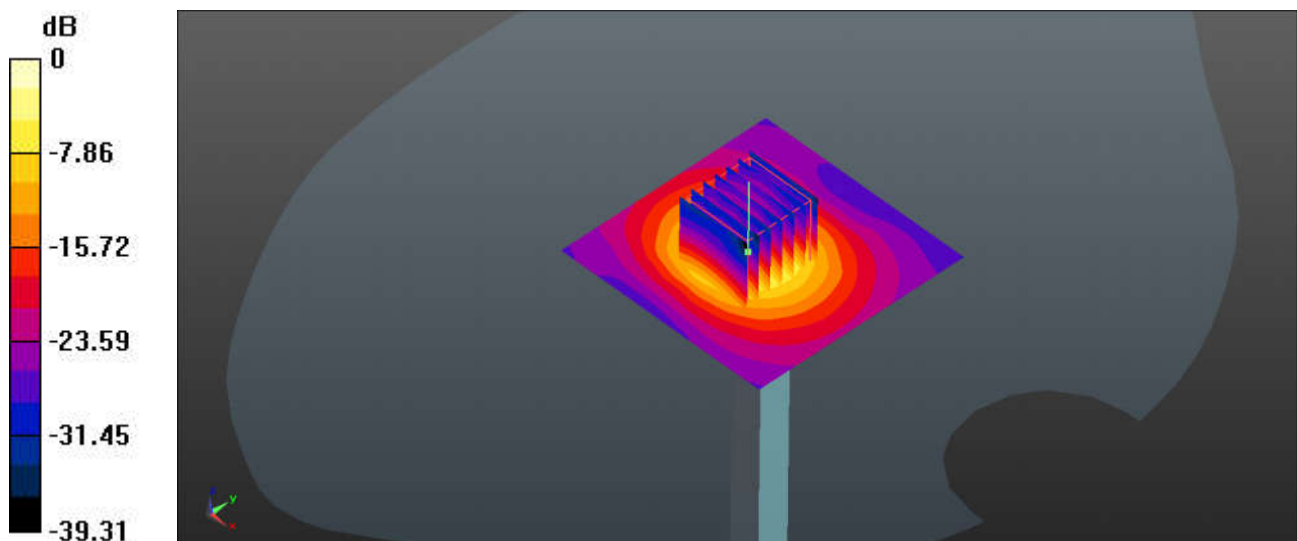

0 dB = 22.3 W/kg

System Check_5600MHz

DUT: D5GHzV2-SN:1341

Communication System: UID 0, CW; Frequency: 5600 MHz; Duty Cycle: 1:1

Medium: HSL_5600_230602 Medium parameters used: $f = 5600$ MHz; $\sigma = 4.856$ S/m; $\epsilon_r = 36.517$; $\rho = 1000$ kg/m³

Ambient Temperature : 23.5 °C; Liquid Temperature : 22.3 °C

DASY5 Configuration:

- Probe: EX3DV4 - SN3887; ConvF(4.19, 4.19, 4.19); Calibrated: 2022/10/28
- Sensor-Surface: 1.4mm (Mechanical Surface Detection)
- Electronics: DAE4 Sn679; Calibrated: 2022/6/6
- Phantom: SAM (Front) with CRP v5.0; Type: QD000P40CD; Serial: TP:1795
- Measurement SW: DASY52, Version 52.10 (3); SEMCAD X Version 14.6.13 (7474)

Pin=100mW/Area Scan (71x71x1): Interpolated grid: dx=1.000 mm, dy=1.000 mm
Maximum value of SAR (interpolated) = 22.1 W/kg

Pin=100mW/Zoom Scan (7x7x7)/Cube 0: Measurement grid: dx=4mm, dy=4mm, dz=1.4mm
Reference Value = 68.74 V/m; Power Drift = 0.09 dB
Peak SAR (extrapolated) = 36.2 W/kg
SAR(1 g) = 8.8 W/kg; SAR(10 g) = 2.48 W/kg
Maximum value of SAR (measured) = 21.6 W/kg

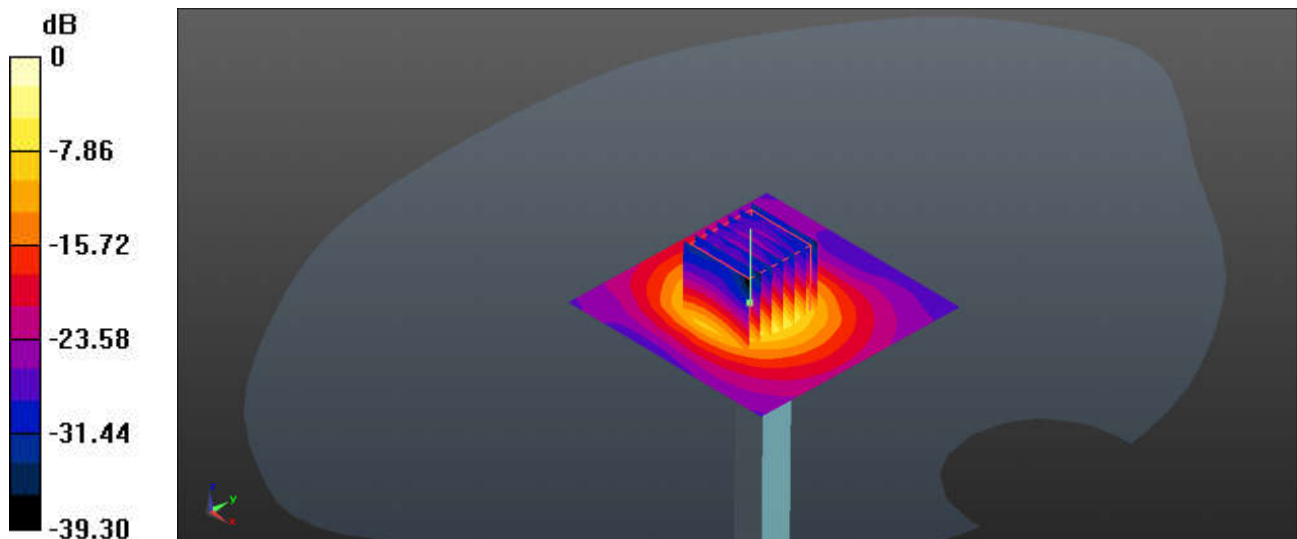

0 dB = 21.6 W/kg

System Check_5750MHz

DUT: D5GHzV2-SN:1341

Communication System: UID 0, CW; Frequency: 5750 MHz; Duty Cycle: 1:1

Medium: HSL_5750_230523 Medium parameters used: $f = 5750$ MHz; $\sigma = 5.358$ S/m; $\epsilon_r = 34.497$; $\rho = 1000$ kg/m³

Ambient Temperature : 23.5 °C; Liquid Temperature : 22.6 °C

DASY5 Configuration:

- Probe: EX3DV4 - SN3887; ConvF(4.34, 4.34, 4.34); Calibrated: 2022/10/28
- Sensor-Surface: 1.4mm (Mechanical Surface Detection)
- Electronics: DAE4 Sn679; Calibrated: 2022/6/6
- Phantom: SAM (Front) with CRP v5.0; Type: QD000P40CD; Serial: TP:1795
- Measurement SW: DASY52, Version 52.10 (3); SEMCAD X Version 14.6.13 (7474)

Pin=100mW/Area Scan (71x71x1): Interpolated grid: dx=1.000 mm, dy=1.000 mm
Maximum value of SAR (interpolated) = 22.7 W/kg

Pin=100mW/Zoom Scan (7x7x7)/Cube 0: Measurement grid: dx=4mm, dy=4mm, dz=1.4mm
Reference Value = 65.34 V/m; Power Drift = 0.12 dB
Peak SAR (extrapolated) = 38.8 W/kg
SAR(1 g) = 8.66 W/kg; SAR(10 g) = 2.15 W/kg
Maximum value of SAR (measured) = 22.9 W/kg

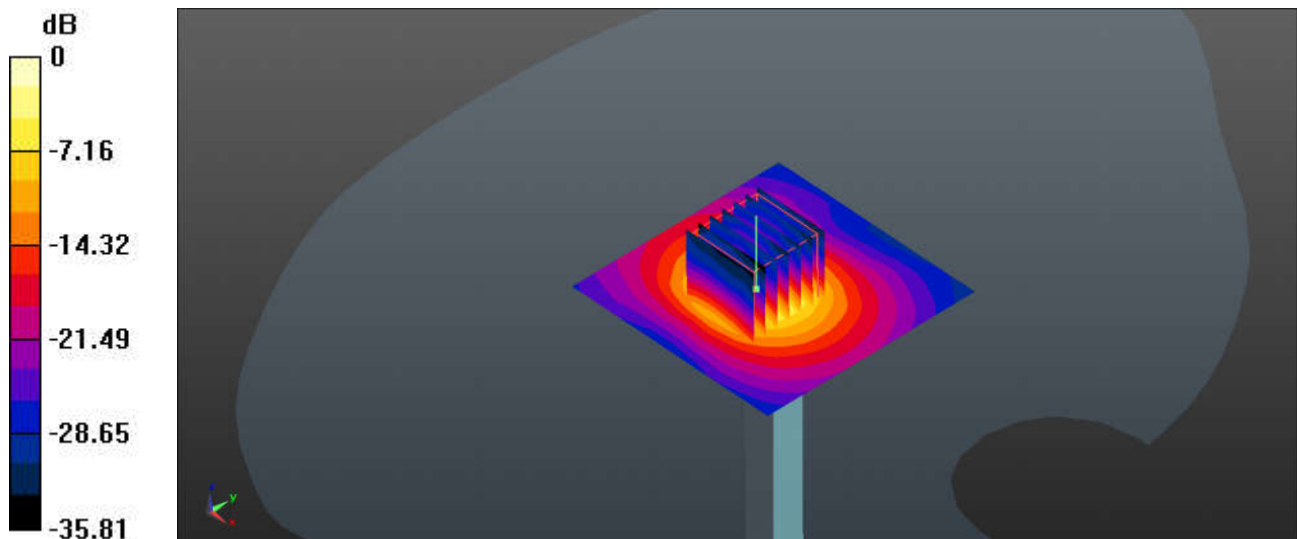

0 dB = 22.9 W/kg

System Check_5750MHz

DUT: D5GHzV2-SN:1341

Communication System: UID 0, CW; Frequency: 5750 MHz; Duty Cycle: 1:1

Medium: HSL_5750_230603 Medium parameters used: $f = 5750$ MHz; $\sigma = 5.014$ S/m; $\epsilon_r = 36.603$; $\rho = 1000$ kg/m³

Ambient Temperature : 23.6 °C; Liquid Temperature : 22.6 °C

DASY5 Configuration:

- Probe: EX3DV4 - SN3887; ConvF(4.34, 4.34, 4.34); Calibrated: 2022/10/28
- Sensor-Surface: 1.4mm (Mechanical Surface Detection)
- Electronics: DAE4 Sn679; Calibrated: 2022/6/6
- Phantom: SAM (Front) with CRP v5.0; Type: QD000P40CD; Serial: TP:1795
- Measurement SW: DASY52, Version 52.10 (3); SEMCAD X Version 14.6.13 (7474)

Pin=100mW/Area Scan (71x71x1): Interpolated grid: dx=1.000 mm, dy=1.000 mm
Maximum value of SAR (interpolated) = 21.1 W/kg

Pin=100mW/Zoom Scan (7x7x7)/Cube 0: Measurement grid: dx=4mm, dy=4mm, dz=1.4mm
Reference Value = 54.99 V/m; Power Drift = 0.08 dB
Peak SAR (extrapolated) = 33.9 W/kg
SAR(1 g) = 8.22 W/kg; SAR(10 g) = 2.32 W/kg
Maximum value of SAR (measured) = 20.2 W/kg

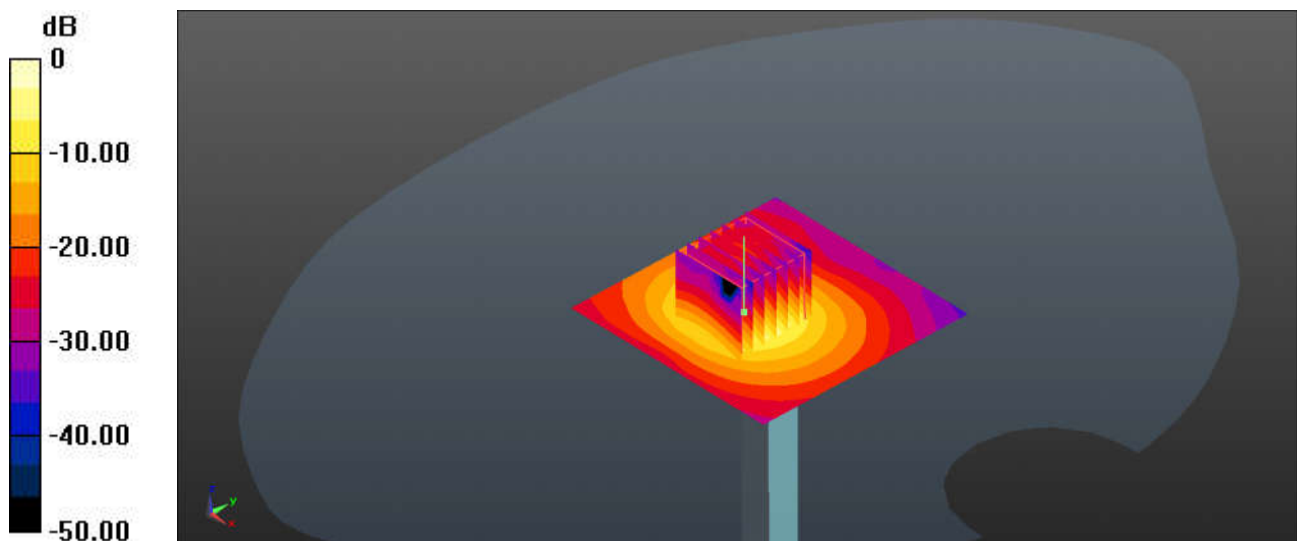

0 dB = 20.2 W/kg

System Check_3500MHz

DUT: D3500V2-SN:1037

Communication System: UID 0, CW (0); Frequency: 3500 MHz; Duty Cycle: 1:1

Medium: HSL_3500_230612 Medium parameters used: $f = 3500$ MHz; $\sigma = 2.868$ S/m; $\epsilon_r = 36.972$; $\rho = 1000$ kg/m³

Ambient Temperature : 23.2 °C; Liquid Temperature : 22.4 °C

DASY5 Configuration:

- Probe: EX3DV4 - SN3887; ConvF(6.57, 6.57, 6.57); Calibrated: 2022/10/28
- Sensor-Surface: 1.4mm (Mechanical Surface Detection)
- Electronics: DAE4 Sn1437; Calibrated: 2022/11/23
- Phantom: SAM (Front) with CRP v5.0; Type: QD000P40CD; Serial: TP:1795
- Measurement SW: DASY52, Version 52.10 (3); SEMCAD X Version 14.6.13 (7474)

Pin=100mW/Area Scan (61x61x1): Interpolated grid: dx=1.200 mm, dy=1.200 mm
Maximum value of SAR (interpolated) = 12.6 W/kg

Pin=100mW/Zoom Scan (7x7x7)/Cube 0: Measurement grid: dx=5mm, dy=5mm, dz=1.4mm
Reference Value = 64.77 V/m; Power Drift = 0.08 dB
Peak SAR (extrapolated) = 16.8 W/kg
SAR(1 g) = 6.34 W/kg; SAR(10 g) = 2.44 W/kg
Maximum value of SAR (measured) = 12.4 W/kg

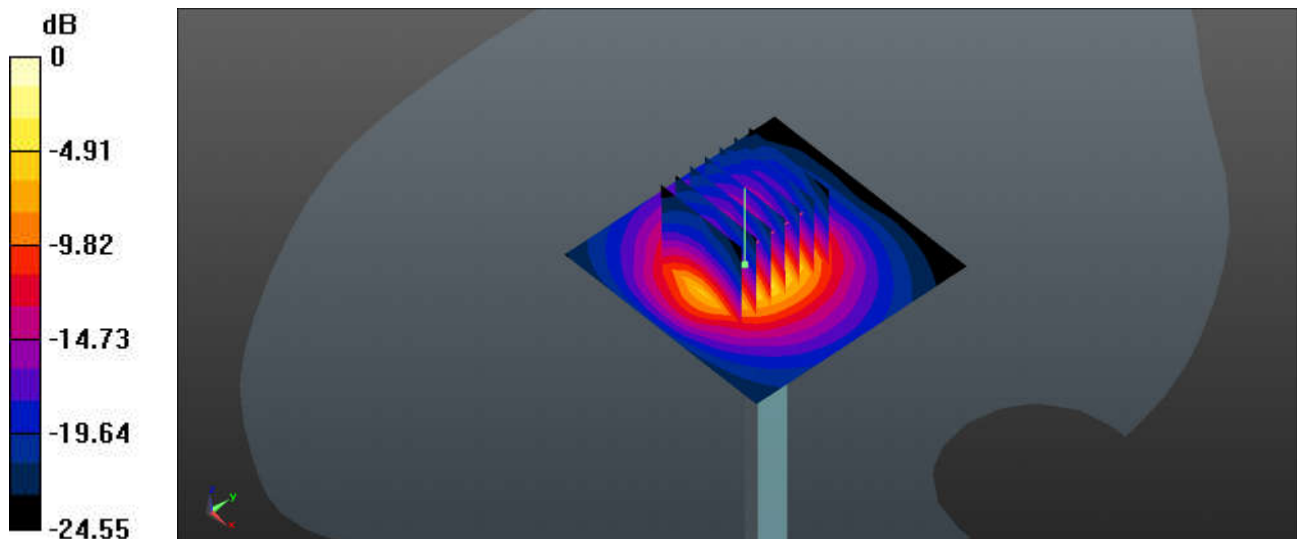

0 dB = 12.4 W/kg

System Check_3700MHz

DUT: D3700V2-SN:1008

Communication System: UID 0, CW (0); Frequency: 3700 MHz; Duty Cycle: 1:1

Medium: HSL_3700_230612 Medium parameters used: $f = 3700$ MHz; $\sigma = 3.011$ S/m; $\epsilon_r = 36.767$; $\rho = 1000$ kg/m³

Ambient Temperature : 23.3 °C; Liquid Temperature : 22.5 °C

DASY5 Configuration:

- Probe: EX3DV4 - SN3887; ConvF(6.35, 6.35, 6.35); Calibrated: 2022/10/28
- Sensor-Surface: 1.4mm (Mechanical Surface Detection)
- Electronics: DAE4 Sn1437; Calibrated: 2022/11/23
- Phantom: SAM (Front) with CRP v5.0; Type: QD000P40CD; Serial: TP:1795
- Measurement SW: DASY52, Version 52.10 (3); SEMCAD X Version 14.6.13 (7474)

Pin=100mW/Area Scan (61x61x1): Interpolated grid: dx=1.200 mm, dy=1.200 mm
Maximum value of SAR (interpolated) = 12.9 W/kg

Pin=100mW/Zoom Scan (7x7x7)/Cube 0: Measurement grid: dx=5mm, dy=5mm, dz=1.4mm
Reference Value = 65.75 V/m; Power Drift = 0.03 dB
Peak SAR (extrapolated) = 17.8 W/kg
SAR(1 g) = 6.38 W/kg; SAR(10 g) = 2.37 W/kg
Maximum value of SAR (measured) = 12.8 W/kg

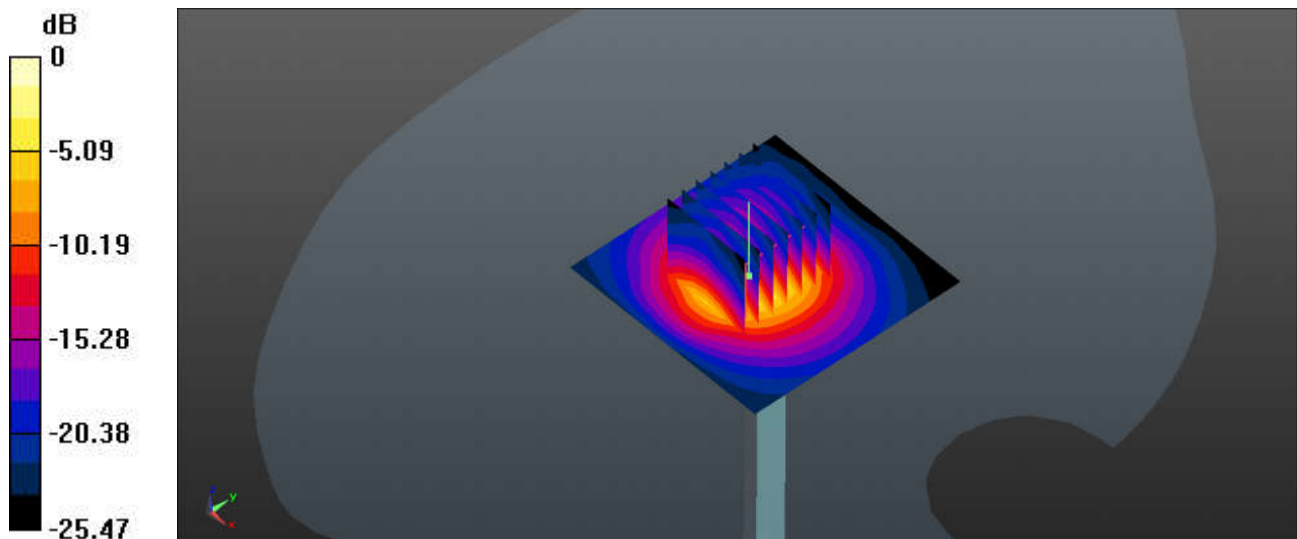

0 dB = 12.8 W/kg

System Check_3900MHz

DUT: D3900V2-SN:1022

Communication System: UID 0, CW (0); Frequency: 3900 MHz; Duty Cycle: 1:1

Medium: HSL_3900_230613 Medium parameters used: $f = 3900$ MHz; $\sigma = 3.165$ S/m; $\epsilon_r = 36.566$; $\rho = 1000$ kg/m³

Ambient Temperature : 23.3 °C; Liquid Temperature : 22.6 °C

DASY5 Configuration:

- Probe: EX3DV4 - SN3887; ConvF(6.13, 6.13, 6.13); Calibrated: 2022/10/28
- Sensor-Surface: 1.4mm (Mechanical Surface Detection)
- Electronics: DAE4 Sn1437; Calibrated: 2022/11/23
- Phantom: SAM (Front) with CRP v5.0; Type: QD000P40CD; Serial: TP:1795
- Measurement SW: DASY52, Version 52.10 (3); SEMCAD X Version 14.6.13 (7474)

Pin=100mW/Area Scan (61x61x1): Interpolated grid: dx=1.200 mm, dy=1.200 mm
Maximum value of SAR (interpolated) = 12.4 W/kg

Pin=100mW/Zoom Scan (7x7x7)/Cube 0: Measurement grid: dx=5mm, dy=5mm, dz=1.4mm
Reference Value = 66.97 V/m; Power Drift = -0.09 dB
Peak SAR (extrapolated) = 17.2 W/kg
SAR(1 g) = 6.19 W/kg; SAR(10 g) = 2.23 W/kg
Maximum value of SAR (measured) = 12.5 W/kg

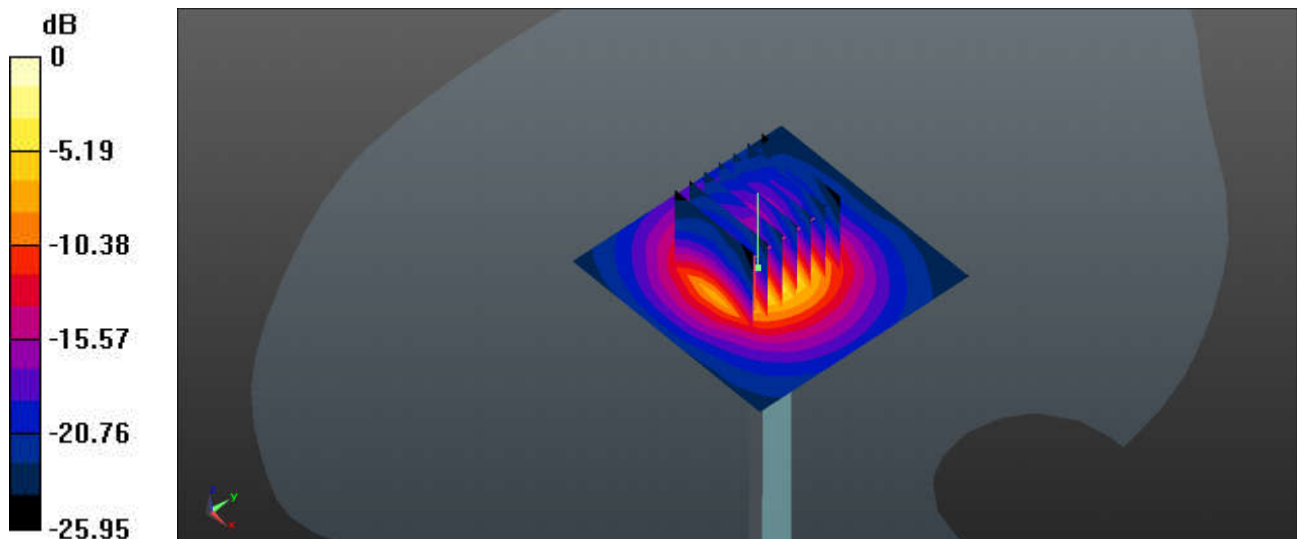

0 dB = 12.5 W/kg