



SAR TEST REPORT

No. I19Z62195-SEM01

For

Xiaomi Communications Co., Ltd.

Mobile Phone

Model name: M2001J2G /M2001J1G

With

Hardware Version: P2.2

Software Version: MIUI 11

FCC ID: 2AFZZJAG

Issued Date: 2020-3-3

Note:

The test results in this test report relate only to the devices specified in this report. This report shall not be reproduced except in full without the written approval of CTTL.

The report must not be used by the client to claim product certification, approval, or endorsement by NVLAP, NIST, or any agency of the U.S. Government.

Test Laboratory:

CTTL, Telecommunication Technology Labs, CAICT

No. 51, Xueyuan Road, Haidian District, Beijing, P. R. China 100191.

Tel:+86(0)10-62304633-2512, Fax:+86(0)10-62304633-2504

Email: ctl_terminals@caict.ac.cn, website: www.caict.ac.cn

**REPORT HISTORY**

Report Number	Revision	Issue Date	Description
I19Z62195-SEM01	Rev.0	2020-2-24	Initial creation of test report
I19Z62195-SEM01	Rev.0	2020-3-3	Update the information on section 2 of test report. Update the information on section 13 of test report.

TABLE OF CONTENT

1 TEST LABORATORY	5
1.1 TESTING LOCATION	5
1.2 TESTING ENVIRONMENT.....	5
1.3 PROJECT DATA	5
1.4 SIGNATURE.....	5
2 STATEMENT OF COMPLIANCE	6
3 CLIENT INFORMATION	8
3.1 APPLICANT INFORMATION	8
3.2 MANUFACTURER INFORMATION	8
4 EQUIPMENT UNDER TEST (EUT) AND ANCILLARY EQUIPMENT (AE)	9
4.1 ABOUT EUT	9
4.2 INTERNAL IDENTIFICATION OF EUT USED DURING THE TEST	9
4.3 INTERNAL IDENTIFICATION OF AE USED DURING THE TEST	9
5 TEST METHODOLOGY	10
5.1 APPLICABLE LIMIT REGULATIONS	10
5.2 APPLICABLE MEASUREMENT STANDARDS.....	10
6 SPECIFIC ABSORPTION RATE (SAR).....	11
6.1 INTRODUCTION.....	11
6.2 SAR DEFINITION.....	11
7 TISSUE SIMULATING LIQUIDS	12
7.1 TARGETS FOR TISSUE SIMULATING LIQUID	12
7.2 DIELECTRIC PERFORMANCE	12
8 SYSTEM VERIFICATION	16
8.1 SYSTEM SETUP.....	16
8.2 SYSTEM VERIFICATION.....	17
9 MEASUREMENT PROCEDURES	18
9.1 TESTS TO BE PERFORMED	18
9.2 GENERAL MEASUREMENT PROCEDURE.....	20
9.3 WCDMA MEASUREMENT PROCEDURES FOR SAR	21
9.4 SAR MEASUREMENT FOR LTE.....	22
9.5 BLUETOOTH & WI-FI MEASUREMENT PROCEDURES FOR SAR	24
9.6 POWER DRIFT.....	24
10 AREA SCAN BASED 1-G SAR.....	25
10.1 REQUIREMENT OF KDB.....	25
10.2 FAST SAR ALGORITHMS	25

11 CONDUCTED OUTPUT POWER	26
11.1 GSM MEASUREMENT RESULT	26
11.2 WCDMA MEASUREMENT RESULT.....	30
11.4 LTE MEASUREMENT RESULT	33
11.4 WI-FI MEASUREMENT RESULT.....	82
11.4 BT MEASUREMENT RESULT	86
12 SIMULTANEOUS TX SAR CONSIDERATIONS	87
12.1 INTRODUCTION.....	87
12.2 TRANSMIT ANTENNA SEPARATION DISTANCES	87
12.3 SAR MEASUREMENT POSITIONS	88
12.4 STANDALONE SAR TEST EXCLUSION CONSIDERATIONS	88
13 EVALUATION OF SIMULTANEOUS	89
14 SAR TEST RESULT	91
14.1 SAR RESULTS FOR SECOND ANTENNA	92
14.2 SAR RESULTS FOR MAIN ANTENNA	100
14.3 SAR RESULTS FOR STANDARD PROCEDURE	110
14.4 WLAN EVALUATION FOR 2.4G	120
14.5 WLAN EVALUATION FOR 5G.....	127
14.6 SAR RESULTS FOR BT	136
15 SAR MEASUREMENT VARIABILITY	138
16 MEASUREMENT UNCERTAINTY	139
16.1 MEASUREMENT UNCERTAINTY FOR NORMAL SAR TESTS (300MHZ~3GHZ).....	139
16.2 MEASUREMENT UNCERTAINTY FOR NORMAL SAR TESTS (3~6GHZ)	140
16.3 MEASUREMENT UNCERTAINTY FOR FAST SAR TESTS (300MHZ~3GHZ)	141
16.4 MEASUREMENT UNCERTAINTY FOR FAST SAR TESTS (3~6GHZ).....	142
17 MAIN TEST INSTRUMENTS	143
ANNEX A GRAPH RESULTS	144
ANNEX B SYSTEM VERIFICATION RESULTS	212
ANNEX C SAR MEASUREMENT SETUP	226
ANNEX D POSITION OF THE WIRELESS DEVICE IN RELATION TO THE PHANTOM	232
ANNEX E EQUIVALENT MEDIA RECIPES	235
ANNEX F SYSTEM VALIDATION	236
ANNEX G PROBE CALIBRATION CERTIFICATE	237
ANNEX H DIPOLE CALIBRATION CERTIFICATE	256
ANNEX I SENSOR TRIGGERING DATA SUMMARY	319
ANNEX I ACCREDITATION CERTIFICATE	322

1 Test Laboratory

1.1 Testing Location

Company Name:	CTTL(Shouxiang)
Address:	No. 51 Shouxiang Science Building, Xueyuan Road, Haidian District, Beijing, P. R. China100191

1.2 Testing Environment

Temperature:	18°C~25°C,
Relative humidity:	30%~ 70%
Ground system resistance:	< 0.5 Ω
Ambient noise & Reflection:	< 0.012 W/kg

1.3 Project Data

Project Leader:	Qi Dianyuan
Test Engineer:	Lin Xiaojun
Testing Start Date:	January 6, 2020
Testing End Date:	January 13, 2020

1.4 Signature



Lin Xiaojun

(Prepared this test report)

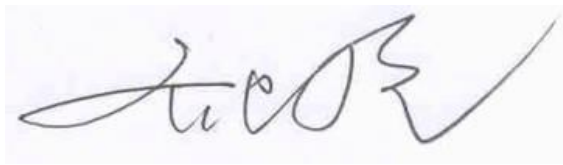

Qi Dianyuan

(Reviewed this test report)

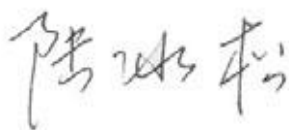

Lu Bingsong

Deputy Director of the laboratory

(Approved this test report)

2 Statement of Compliance

The maximum results of SAR found during testing for Xiaomi Communications Co., Ltd. Mobile Phone M2001J2G /M2001J1G are as follows:

Table 2.1: Highest Reported SAR (1g)

Exposure Configuration	Antenna	Technology Band	Highest Reported SAR 1g(W/kg)	Equipment Class
Head (Separation Distance 0mm)	Main antenna	PCS 1900	0.11	PCE
		UMTS FDD 5	0.24	
		UMTS FDD 4	0.23	
		UMTS FDD 2	0.20	
		LTE Band 2	0.14	
		LTE Band 4	0.11	
		LTE Band 5	0.25	
		LTE Band 7	0.13	
	LTE Band 38	0.07		
	Secondary antenna	GSM 850	0.82	
		PCS 1900	0.70	
		UMTS FDD 5	0.80	
		UMTS FDD 4	0.89	
		UMTS FDD 2	0.72	
		LTE Band 2	0.75	
		LTE Band 4	0.67	
		LTE Band 5	0.79	
LTE Band 7	0.92			
LTE Band 38	0.99			
BT antenna	Bluetooth	0.69	DTS	
WiFi antenna	WLAN 2.4 GHz	0.72	UNII	
	WLAN 5 GHz	1.09		
Hotspot (Separation Distance 10mm)	Main antenna	PCS 1900	0.88	PCE
		UMTS FDD 5	0.47	
		UMTS FDD 4	0.97	
		UMTS FDD 2	0.93	
		LTE Band 2	0.93	
		LTE Band 4	0.91	
		LTE Band 5	0.41	
		LTE Band 7	0.78	
	LTE Band 38	0.62		
	Secondary antenna	GSM 850	0.09	
		PCS 1900	0.39	
		UMTS FDD 5	0.27	
		UMTS FDD 4	0.40	
		UMTS FDD 2	0.79	
		LTE Band 2	0.53	
		LTE Band 4	0.22	
		LTE Band 5	0.25	
LTE Band 7		0.80		
LTE Band 38	0.52			

	BT antenna	Bluetooth	0.34	DTS
	WiFi antenna	WLAN 2.4 GHz	1.10	
			WLAN 5 GHz	0.35
Body-worn (Separation Distance 15mm)	Main antenna	PCS 1900	0.28	PCE
		UMTS FDD 4	1.02	
		UMTS FDD 2	0.96	
		LTE Band 2	0.85	
		LTE Band 4	0.66	
		LTE Band 7	0.62	
		LTE Band 38	0.62	

The SAR values found for the Mobile Phone are below the maximum recommended levels of 1.6 W/kg as averaged over any 1g tissue according to the ANSI C95.1-1992.

For body operation, this device has been tested and meets FCC RF exposure guidelines when used with any accessory that contains no metal and which provides a minimum separation distance of 10 mm for hotspot and 15mm for body worn between this device and the body of the user. Use of other accessories may not ensure compliance with FCC RF exposure guidelines.

The EUT battery must be fully charged and checked periodically during the test to ascertain uniform power output.

The measurement together with the test system set-up is described in annex C of this test report. A detailed description of the equipment under test can be found in chapter 4 of this test report. The highest reported SAR value is obtained at the case of **(Table 2.1)**, and the values are: **1.10 W/kg(1g)**.

Table 2.2: The sum of reported SAR values for main antenna and WiFi2.4G

	Position	Main antenna	WiFi2.4G	Sum
Highest reported SAR value for Head	Right hand, Tilt	0.82	0.72	1.54
Highest reported SAR value for Body	Top 10mm	0.58	0.56	1.14

According to the above tables, the highest sum of reported SAR values is **1.54 W/kg (1g)**. The detail for simultaneous transmission consideration is described in chapter 13.

According to the KDB648474 D04, the UMPC mini-tablet procedures must also be applied to test the SAR of all surfaces and edges with an antenna located at ≤ 25 mm from that surface or edge, in direct contact with a flat phantom, for 10-g extremity SAR according to the body-equivalent tissue dielectric parameters in KDB Publication 865664 D01 to address interactive hand use exposure conditions. When hotspot mode applies, 10-g extremity SAR is required only for the surfaces and edges with hotspot mode 1-g reported SAR > 1.2 W/kg

Table 2.4: 0mm Reported SAR for phablet (10g)

Exposure Configuration	Technology Band	Highest Reported SAR 10g(W/kg)	Limit 10g (W/kg)
Hotspot (Separation Distance 0mm)	WCDMA1900	1.71	4.0
Hotspot (Separation Distance 0mm)	WCDMA1700	2.32	4.0
Hotspot (Separation Distance 0mm)	LTE Band2	0.80	4.0
Hotspot (Separation Distance 0mm)	LTE Band4	2.36	4.0
Hotspot (Separation Distance 0mm)	LTE Band7	2.20	4.0

The detail for 0mm test data is described in chapter 14.2.

3 Client Information

3.1 Applicant Information

Company Name:	Xiaomi Communications Co., Ltd.
Address/Post:	#019, 9th Floor, Building 6, 33 Xi'erqi Middle Road, Haidian District, Beijing, China, 100085
Contact Person:	jiaoxiaogang
Contact Email:	mi-compliance@xiaomi.com
Telephone:	010-60606666-8088
Fax	010-60606666-1101

3.2 Manufacturer Information

Company Name:	Xiaomi Communications Co., Ltd.
Address/Post:	#019, 9th Floor, Building 6, 33 Xi'erqi Middle Road, Haidian District, Beijing, China, 100085
Contact Person:	jiaoxiaogang
Contact Email:	mi-compliance@xiaomi.com
Telephone:	010-60606666-8088
Fax	010-60606666-1101

4 Equipment Under Test (EUT) and Ancillary Equipment (AE)

4.1 About EUT

Description:	Mobile Phone
Model name:	M2001J2G /M2001J1G
Operating mode(s):	GSM 850/900/1800/1900, UMTS FDD 1/2/4/5/8, BT, Wi-Fi(2.4G/5G), LTE Band 1/2/3/4/5/7/8/20/28/32/38
Tested Tx Frequency:	824 – 849 MHz (GSM 850)
	1850 – 1910 MHz (GSM 1900)
	824–849 MHz (WCDMA 850 Band V)
	1710 – 1755 MHz (WCDMA 1700 Band IV)
	1850–1910 MHz (WCDMA1900 Band II)
	1860 – 1900 MHz (LTE Band 2)
	1710-1755 MHz (LTE Band 4)
	824-849 MHz (LTE Band 5)
	2502.5 – 2567.5 MHz(LTE Band 7)
	2570 – 2620 MHz (LTE Band 38)
	2412 – 2462 MHz (Wi-Fi 2.4G)
5.15 – 5.825 GHz(Wi-Fi 5G)	
GPRS/EGPRS Multislot Class:	33
GPRS capability Class:	B
Test device Production information:	Production unit
Device type:	Portable device
Antenna type:	Integrated antenna
Hotspot mode:	Support

4.2 Internal Identification of EUT used during the test

EUT ID*	IMEI	HW	SW Version
EUT1	860211040037055	P2.2	MIUI 11
EUT2	860211040037113	P2.2	MIUI 11
EUT3	860211040037352	P2.2	MIUI 11
EUT4	860211040037659	P2.2	MIUI 11
EUT5	860211040064216	P2.2	MIUI 11
EUT6	860211040064075	P2.2	MIUI 11
EUT7	261543040045756	P2.2	MIUI 11
EUT8	861543040045772	P2.2	MIUI 11
EUT9	860211040037758	P2.2	MIUI 11
EUT10	860211040037311	P2.2	MIUI 11

*EUT ID: is used to identify the test sample in the lab internally.

Note: It is performed to test SAR with the EUT1~8 and conducted power with the EUT9~10.

4.3 Internal Identification of AE used during the test

AE ID*	Description	Model	SN	Manufacturer
AE1	Battery	Li-ion	BM4M	Ningde Amperex Technology Ltd.
AE2	Headset	EM023	/	One more acoustics technology co., LTD

*AE ID: is used to identify the test sample in the lab internally.

5 TEST METHODOLOGY

5.1 Applicable Limit Regulations

ANSI C95.1–1992: IEEE Standard for Safety Levels with Respect to Human Exposure to Radio Frequency Electromagnetic Fields, 3 kHz to 300 GHz.

It specifies the maximum exposure limit of **1.6 W/kg** as averaged over any 1 gram of tissue for portable devices being used within 20 cm of the user in the uncontrolled environment.

5.2 Applicable Measurement Standards

IEEE 1528–2013: Recommended Practice for Determining the Peak Spatial-Average Specific Absorption Rate (SAR) in the Human Head from Wireless Communications Devices: Measurement Techniques.

KDB447498 D01: General RF Exposure Guidance v06: Mobile and Portable Devices RF Exposure Procedures and Equipment Authorization Policies.

KDB648474 D04 Handset SAR v01r03: SAR Evaluation Considerations for Wireless Handsets.

KDB941225 D01 SAR test for 3G devices v03r01: SAR Measurement Procedures for 3G Devices

KDB941225 D05 SAR for LTE Devices v02r05: SAR Evaluation Considerations for LTE Devices

KDB941225 D06 Hotspot Mode SAR v02r01: SAR Evaluation Procedures for Portable Devices with Wireless Router Capabilities

KDB248227 D01 802.11 Wi-Fi SAR v02r02: SAR GUIDANCE FOR IEEE 802.11 (Wi-Fi) TRANSMITTERS

KDB865664 D01 SAR measurement 100 MHz to 6 GHz v01r04: SAR Measurement Requirements for 100 MHz to 6 GHz.

KDB865664 D02 RF Exposure Reporting v01r02: RF Exposure Compliance Reporting and Documentation Considerations

6 Specific Absorption Rate (SAR)

6.1 Introduction

SAR is related to the rate at which energy is absorbed per unit mass in an object exposed to a radio field. The SAR distribution in a biological body is complicated and is usually carried out by experimental techniques or numerical modeling. The standard recommends limits for two tiers of groups, occupational/controlled and general population/uncontrolled, based on a person's awareness and ability to exercise control over his or her exposure. In general, occupational/controlled exposure limits are higher than the limits for general population/uncontrolled.

6.2 SAR Definition

The SAR definition is the time derivative (rate) of the incremental energy (dW) absorbed by (dissipated in) an incremental mass (dm) contained in a volume element (dv) of a given density (ρ). The equation description is as below:

$$SAR = \frac{d}{dt} \left(\frac{dW}{dm} \right) = \frac{d}{dt} \left(\frac{dW}{\rho dv} \right)$$

SAR is expressed in units of Watts per kilogram (W/kg)

SAR measurement can be either related to the temperature elevation in tissue by

$$SAR = c \left(\frac{\delta T}{\delta t} \right)$$

Where: C is the specific heat capacity, δT is the temperature rise and δt is the exposure duration, or related to the electrical field in the tissue by

$$SAR = \frac{\sigma |E|^2}{\rho}$$

Where: σ is the conductivity of the tissue, ρ is the mass density of tissue and E is the RMS electrical field strength.

However for evaluating SAR of low power transmitter, electrical field measurement is typically applied.

7 Tissue Simulating Liquids

7.1 Targets for tissue simulating liquid

Table 7.1: Targets for tissue simulating liquid

Frequency(MHz)	Liquid Type	Conductivity(σ)	$\pm 5\%$ Range	Permittivity(ϵ)	$\pm 5\%$ Range
835	Head	0.90	0.86~0.95	41.5	39.4~43.6
1750	Head	1.37	1.30~1.44	40.08	38.1~42.1
1900	Head	1.40	1.33~1.47	40.0	38.0~42.0
2450	Head	1.80	1.71~1.89	39.2	37.2~41.2
2600	Head	1.96	1.86~2.06	39.01	37.1~41.0
5250	Head	4.71	4.47~4.95	35.93	34.13~37.73
5600	Head	5.07	4.82~5.32	35.53	33.8~37.3
5750	Head	5.22	4.96~5.48	35.36	33.59~37.13

7.2 Dielectric Performance

Table 7.2: Dielectric Performance of Tissue Simulating Liquid

Measurement Date (yyyy-mm-dd)	Type	Frequency	Permittivity ϵ	Drift (%)	Conductivity σ (S/m)	Drift (%)
2020-1-6	Head	835 MHz	41.34	-0.39	0.892	-0.89
2020-1-7	Head	835 MHz	42.26	1.83	0.905	0.56
2020-1-8	Head	1750 MHz	40.66	1.45	1.374	0.29
2020-1-9	Head	1750 MHz	40.07	-0.02	1.397	1.97
2020-1-10	Head	1900 MHz	40.54	1.35	1.4	0.00
2020-1-11	Head	1900 MHz	39.78	-0.55	1.385	-1.07
2020-1-12	Head	2450 MHz	38.43	-1.96	1.777	-1.28
2020-1-13	Head	2450 MHz	39.25	0.13	1.767	-1.83
2020-1-14	Head	2600 MHz	39.12	0.28	1.937	-1.17
2020-1-15	Head	2600 MHz	38.79	-0.56	1.978	0.92
2020-1-16	Head	5250 MHz	35.37	-1.56	4.746	0.76
2020-1-17	Head	5600 MHz	36.1	1.60	5.12	0.99
2020-1-18	Head	5750 MHz	35.36	0.00	5.21	-0.19

Note: The liquid temperature is 22.0°C

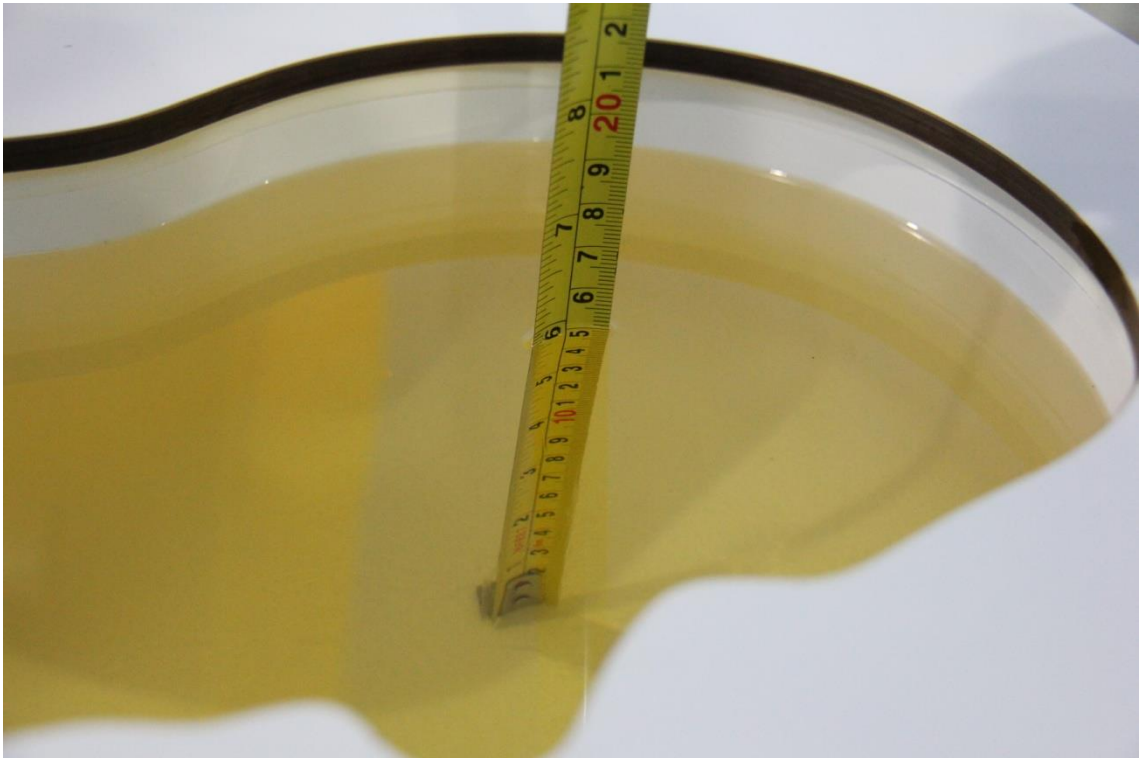

Picture 7-1 Liquid depth in the Head Phantom (835 MHz)



Picture 7-2 Liquid depth in the Head Phantom (1750 MHz)

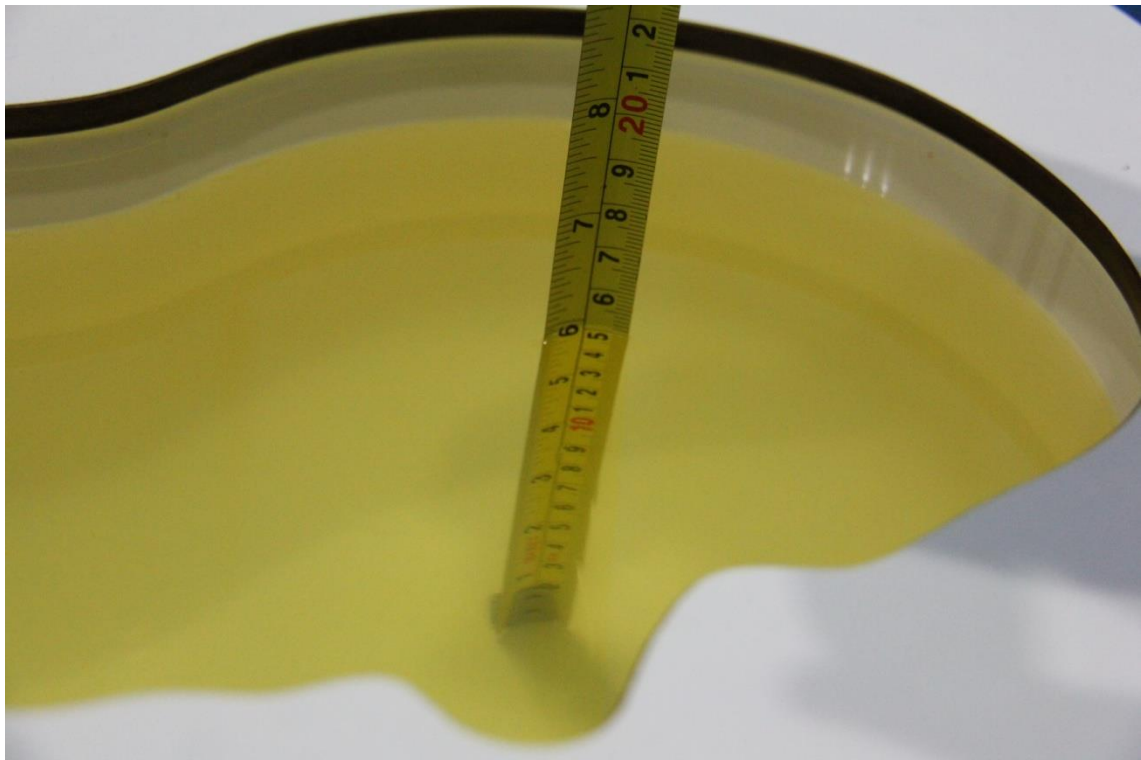

Picture 7-3 Liquid depth in the Head Phantom (1900 MHz)



Picture 7-4 Liquid depth in the Head Phantom (2450MHz)

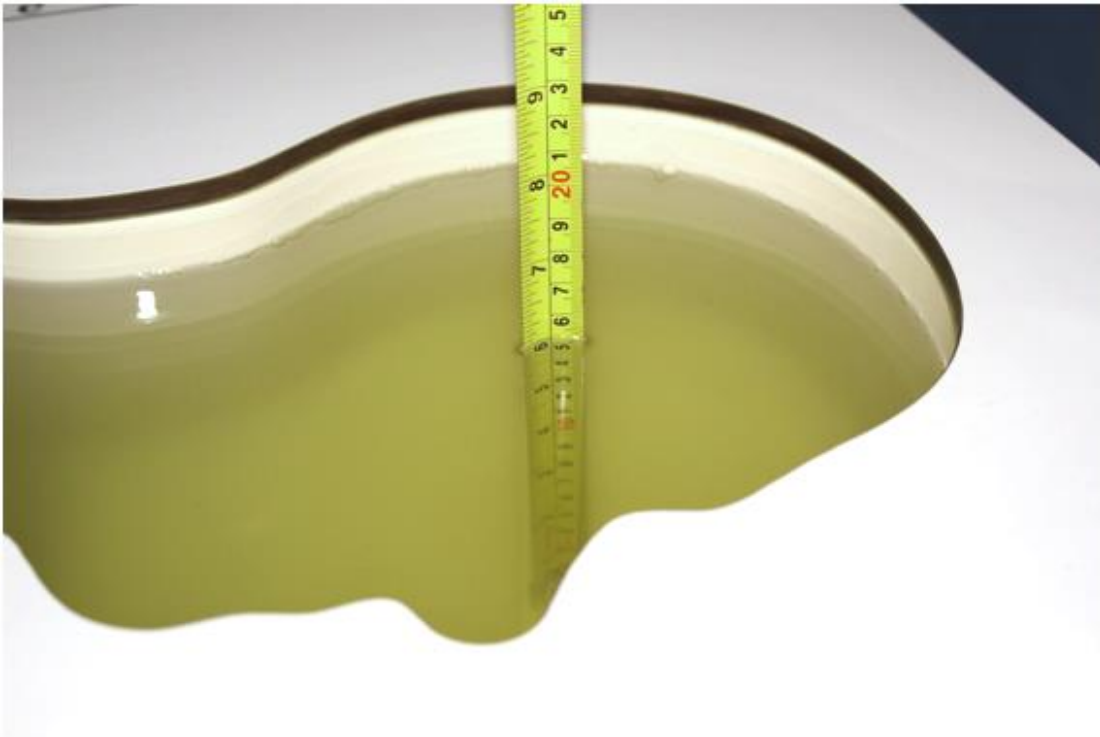

Picture 7-5 Liquid depth in the Head Phantom (2600 MHz)



Picture 7-6 Liquid depth in the Head Phantom (5GHz)

8 System verification

8.1 System Setup

In the simplified setup for system evaluation, the DUT is replaced by a calibrated dipole and the power source is replaced by a continuous wave that comes from a signal generator. The calibrated dipole must be placed beneath the flat phantom section of the SAM twin phantom with the correct distance holder. The distance holder should touch the phantom surface with a light pressure at the reference marking and be oriented parallel to the long side of the phantom. The equipment setup is shown below:

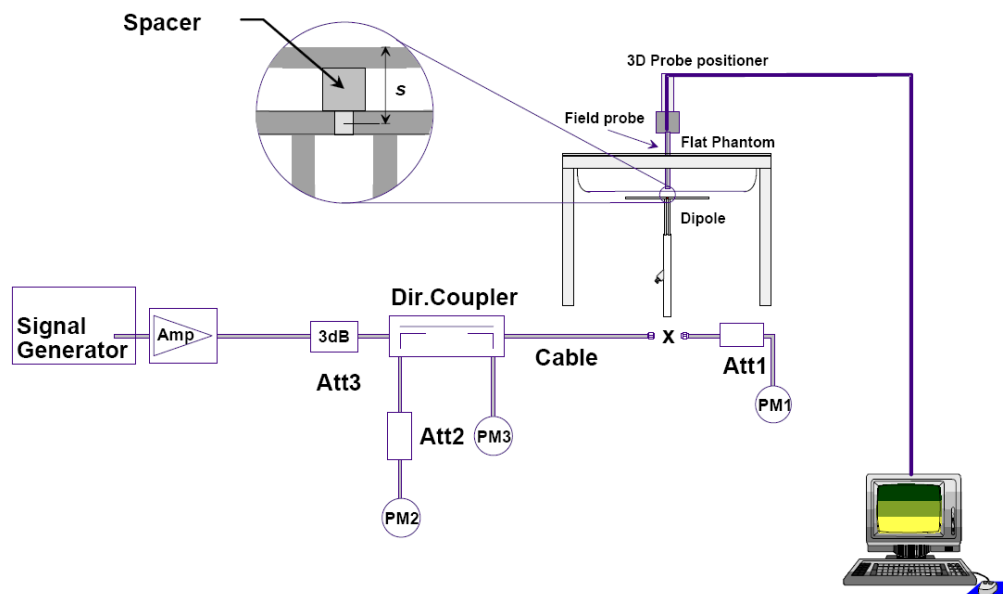

Picture 8.1 System Setup for System Evaluation



Picture 8.2 Photo of Dipole Setup

8.2 System Verification

SAR system verification is required to confirm measurement accuracy, according to the tissue dielectric media, probe calibration points and other system operating parameters required for measuring the SAR of a test device. The system verification must be performed for each frequency band and within the valid range of each probe calibration point required for testing the device.

The system verification results are required that the area scan estimated 1-g SAR is within 3% of the zoom scan 1-g SAR. The details are presented in annex B.

Table 8.1: System Verification of Head

Measurement Date (yyyy-mm-dd)	Frequency	Target value (W/kg)		Measured value(W/kg)		Deviation	
		10 g Average	1 g Average	10 g Average	1 g Average	10 g Average	1 g Average
2020-1-6	835 MHz	6.29	9.70	6.4	9.88	1.75%	1.86%
2020-1-7	835 MHz	6.29	9.70	6.28	9.72	-0.16%	0.21%
2020-1-8	1750 MHz	19.3	36.6	19.4	37.16	0.52%	1.53%
2020-1-9	1750 MHz	19.3	36.6	19.6	36.6	1.55%	0.00%
2020-1-10	1900 MHz	20.8	39.7	20.4	40.48	-1.92%	1.96%
2020-1-11	1900 MHz	20.8	39.7	21.04	39	1.15%	-1.76%
2020-1-12	2450 MHz	24.2	51.6	24.04	52.2	-0.66%	1.16%
2020-1-13	2450 MHz	24.2	51.6	24.12	50.6	-0.33%	-1.94%
2020-1-14	2600 MHz	25.1	55.8	25.6	55.6	1.99%	-0.36%
2020-1-15	2600 MHz	25.1	55.8	24.8	55.8	-1.20%	0.00%
2020-1-16	5250 MHz	23.2	80.4	23.1	81.1	-0.34%	0.90%
2020-1-17	5600 MHz	24.1	84.5	24.4	83.7	1.24%	-0.92%
2020-1-118	5750 MHz	23.0	80.4	23.0	80.2	0.17%	-0.30%

9 Measurement Procedures

9.1 Tests to be performed

In order to determine the highest value of the peak spatial-average SAR of a handset, all device positions, configurations and operational modes shall be tested for each frequency band according to steps 1 to 3 below. A flowchart of the test process is shown in picture 9.1.

Step 1: The tests described in 9.2 shall be performed at the channel that is closest to the centre of the transmit frequency band (f_c) for:

- a) all device positions (cheek and tilt, for both left and right sides of the SAM phantom, as described in annex D),
- b) all configurations for each device position in a), e.g., antenna extended and retracted, and
- c) all operational modes, e.g., analogue and digital, for each device position in a) and configuration in b) in each frequency band.

If more than three frequencies need to be tested according to 11.1 (i.e., $N_c > 3$), then all frequencies, configurations and modes shall be tested for all of the above test conditions.

Step 2: For the condition providing highest peak spatial-average SAR determined in Step 1, perform all tests described in 9.2 at all other test frequencies, i.e., lowest and highest frequencies. In addition, for all other conditions (device position, configuration and operational mode) where the peak spatial-average SAR value determined in Step 1 is within 3 dB of the applicable SAR limit, it is recommended that all other test frequencies shall be tested as well.

Step 3: Examine all data to determine the highest value of the peak spatial-average SAR found in Steps 1 to 2.

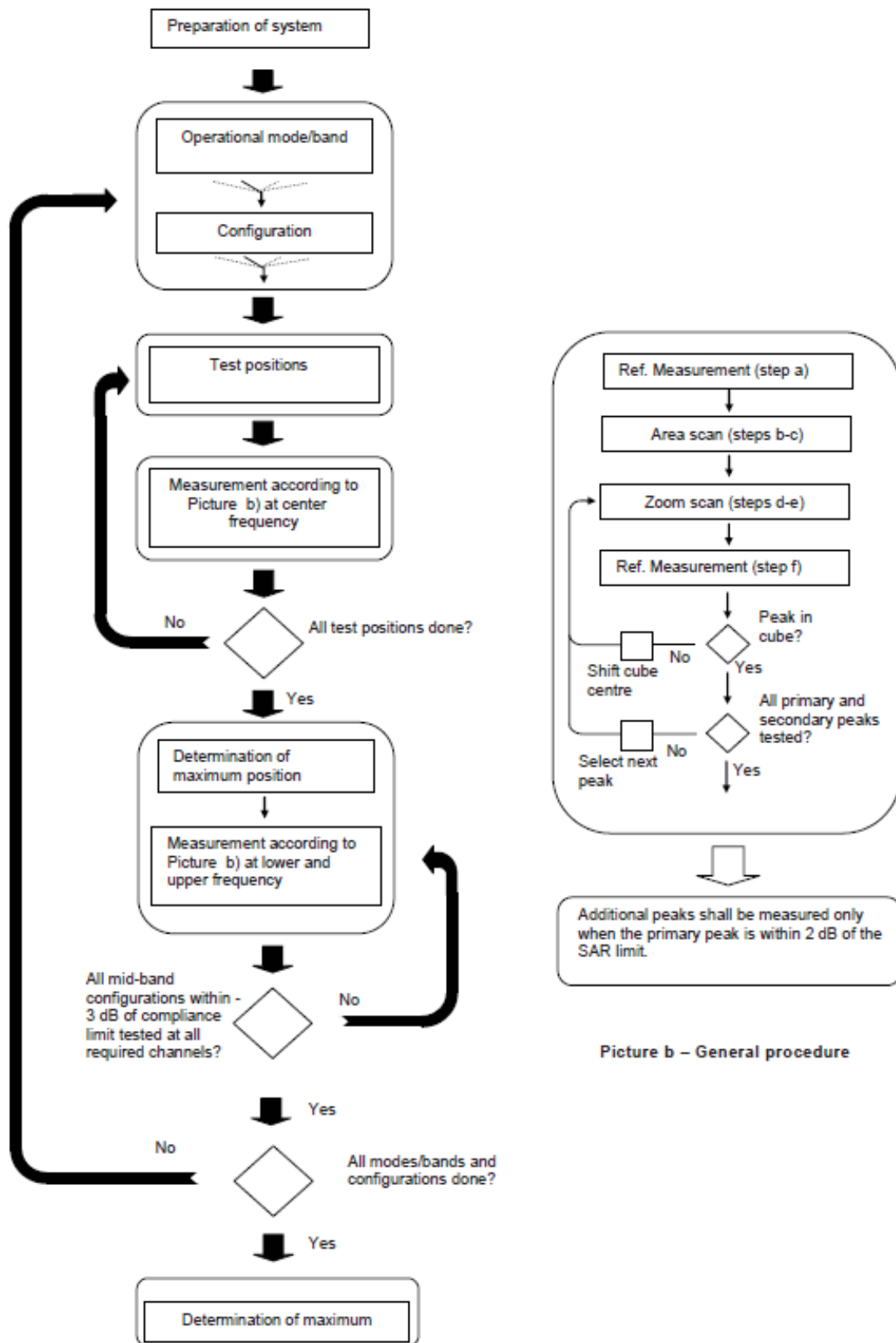

Picture a – Tests to be performed

Picture b – General procedure

Picture 9.1 Block diagram of the tests to be performed

9.2 General Measurement Procedure

The area and zoom scan resolutions specified in the table below must be applied to the SAR measurements and fully documented in SAR reports to qualify for TCB approval. Probe boundary effect error compensation is required for measurements with the probe tip closer than half a probe tip diameter to the phantom surface. Both the probe tip diameter and sensor offset distance must satisfy measurement protocols; to ensure probe boundary effect errors are minimized and the higher fields closest to the phantom surface can be correctly measured and extrapolated to the phantom surface for computing 1-g SAR. Tolerances of the post-processing algorithms must be verified by the test laboratory for the scan resolutions used in the SAR measurements, according to the reference distribution functions specified in IEEE Std 1528-2003. The results should be documented as part of the system validation records and may be requested to support test results when all the measurement parameters in the following table are not satisfied.

		≤ 3 GHz	> 3 GHz	
Maximum distance from closest measurement point (geometric center of probe sensors) to phantom surface		5 ± 1 mm	$\frac{1}{2} \cdot \delta \cdot \ln(2) \pm 0.5$ mm	
Maximum probe angle from probe axis to phantom surface normal at the measurement location		$30^\circ \pm 1^\circ$	$20^\circ \pm 1^\circ$	
Maximum area scan spatial resolution: Δx_{Area} , Δy_{Area}		≤ 2 GHz: ≤ 15 mm 2 – 3 GHz: ≤ 12 mm	3 – 4 GHz: ≤ 12 mm 4 – 6 GHz: ≤ 10 mm	
		When the x or y dimension of the test device, in the measurement plane orientation, is smaller than the above, the measurement resolution must be \leq the corresponding x or y dimension of the test device with at least one measurement point on the test device.		
Maximum zoom scan spatial resolution: Δx_{Zoom} , Δy_{Zoom}		≤ 2 GHz: ≤ 8 mm 2 – 3 GHz: ≤ 5 mm*	3 – 4 GHz: ≤ 5 mm* 4 – 6 GHz: ≤ 4 mm*	
Maximum zoom scan spatial resolution, normal to phantom surface	uniform grid: $\Delta z_{Zoom}(n)$	≤ 5 mm	3 – 4 GHz: ≤ 4 mm 4 – 5 GHz: ≤ 3 mm 5 – 6 GHz: ≤ 2 mm	
	graded grid	$\Delta z_{Zoom}(1)$: between 1 st two points closest to phantom surface	≤ 4 mm	3 – 4 GHz: ≤ 3 mm 4 – 5 GHz: ≤ 2.5 mm 5 – 6 GHz: ≤ 2 mm
		$\Delta z_{Zoom}(n>1)$: between subsequent points	$\leq 1.5 \cdot \Delta z_{Zoom}(n-1)$	
Minimum zoom scan volume	x, y, z	≥ 30 mm	3 – 4 GHz: ≥ 28 mm 4 – 5 GHz: ≥ 25 mm 5 – 6 GHz: ≥ 22 mm	
Note: δ is the penetration depth of a plane-wave at normal incidence to the tissue medium; see draft standard IEEE P1528-2011 for details.				
* When zoom scan is required and the <i>reported</i> SAR from the area scan based 1-g SAR estimation procedures of KDB 447498 is ≤ 1.4 W/kg, ≤ 8 mm, ≤ 7 mm and ≤ 5 mm zoom scan resolution may be applied, respectively, for 2 GHz to 3 GHz, 3 GHz to 4 GHz and 4 GHz to 6 GHz.				

9.3 WCDMA Measurement Procedures for SAR

The following procedures are applicable to WCDMA handsets operating under 3GPP Release99, Release 5 and Release 6. The default test configuration is to measure SAR with an established radio link between the DUT and a communication test set using a 12.2kbps RMC (reference measurement channel) configured in Test Loop Mode 1. SAR is selectively confirmed for other physical channel configurations (DPCCH & DPDCH_n), HSDPA and HSPA (HSUPA/HSDPA) modes according to output power, exposure conditions and device operating capabilities. Both uplink and downlink should be configured with the same RMC or AMR, when required. SAR for Release 5 HSDPA and Release 6 HSPA are measured using the applicable FRC (fixed reference channel) and E-DCH reference channel configurations. Maximum output power is verified according to applicable versions of 3GPP TS 34.121 and SAR must be measured according to these maximum output conditions. When Maximum Power Reduction (MPR) is not implemented according to Cubic Metric (CM) requirements for Release 6 HSPA, the following procedures do not apply.

For Release 5 HSDPA Data Devices:

Sub-test	β_c	β_d	β_d (SF)	β_c/β_d	β_{hs}	CM/dB
1	2/15	15/15	64	2/15	4/15	0.0
2	12/15	15/15	64	12/15	24/25	1.0
3	15/15	8/15	64	15/8	30/15	1.5
4	15/15	4/15	64	15/4	30/15	1.5

For Release 6 HSPA Data Devices

Sub-test	β_c	β_d	β_d (SF)	β_c/β_d	β_{hs}	β_{ec}	β_{ed}	β_{ed} (SF)	β_{ed} (codes)	CM (dB)	MPR (dB)	AG Index	E-TFCI
1	11/15	15/15	64	11/15	22/15	209/225	1039/225	4	1	1.5	1.5	20	75
2	6/15	15/15	64	6/15	12/15	12/15	12/15	4	1	1.5	1.5	12	67
3	15/15	9/15	64	15/9	30/15	30/15	$\beta_{ed1}:47/15$ $\beta_{ed2}:47/15$	4	2	1.5	1.5	15	92
4	2/15	15/15	64	2/15	4/15	4/15	56/75	4	1	1.5	1.5	17	71
5	15/15	15/15	64	15/15	24/15	30/15	134/15	4	1	1.5	1.5	21	81

Rel.8 DC-HSDPA (Cat 24)

SAR test exclusion for Rel.8 DC-HSDPA must satisfy the SAR test exclusion requirements of Rel.5 HSDPA. SAR test exclusion for DC-HSDPA devices is determined by power measurements according to the H-Set 12, Fixed Reference Channel (FRC) configuration in Table C.8.1.12 of 3GPP TS 34.121-1. A primary and a secondary serving HS-DSCH Cell are required to perform the power measurement and for the results to qualify for SAR test exclusion.

9.4 SAR Measurement for LTE

SAR tests for LTE are performed with a base station simulator, Rohde & Schwarz CMW500. Closed loop power control was used so the UE transmits with maximum output power during SAR testing. All powers were measured with the CMW 500.

It is performed for conducted power and SAR based on the KDB941225 D05.

SAR is evaluated separately according to the following procedures for the different test positions in each exposure condition – head, body, body-worn accessories and other use conditions. The procedures in the following subsections are applied separately to test each LTE frequency band.

1) QPSK with 1 RB allocation

Start with the largest channel bandwidth and measure SAR for QPSK with 1 RB allocation, using the RB offset and required test channel combination with the highest maximum output power among RB offsets at the upper edge, middle and lower edge of each required test channel. When the reported SAR is ≤ 0.8 W/kg, testing of the remaining RB offset configurations and required test channels is not required for 1 RB allocation; otherwise, SAR is required for the remaining required test channels and only for the RB offset configuration with the highest output power for that channel. When the reported SAR of a required test channel is > 1.45 W/kg, SAR is required for all three RB offset configurations for that required test channel.

2) QPSK with 50% RB allocation

The procedures required for 1 RB allocation in 1) are applied to measure the SAR for QPSK with 50% RB allocation.

3) QPSK with 100% RB allocation

For QPSK with 100% RB allocation, SAR is not required when the highest maximum output power for 100 % RB allocation is less than the highest maximum output power in 50% and 1 RB allocations and the highest reported SAR for 1 RB and 50% RB allocation in 1) and 2) are ≤ 0.8 W/kg. Otherwise, SAR is measured for the highest output power channel; and if the reported SAR is > 1.45 W/kg, the remaining required test channels must also be tested.

TDD test:

TDD testing is performed using guidance from FCC KDB 941225 D05 v02r05 and the SAR test guidance provided in April 2013 TCB works hop notes. TDD is tested at the highest duty factor using UL-DL configuration 0 with special subframe configuration 6 and applying the FDD LTE procedures in KDB 941225 D05 v02r05. SAR testing is performed using the extended cyclic prefix listed in 3GPP TS 36.211.

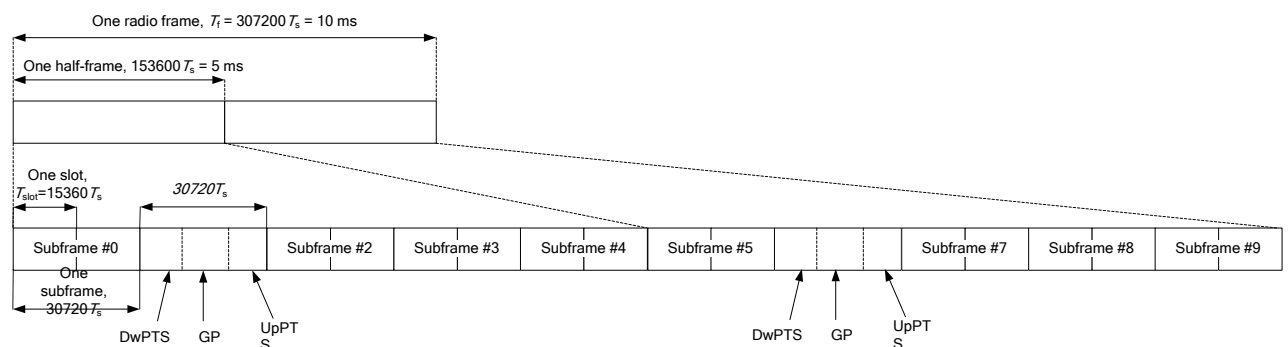

Figure 9.2: Frame structure type 2 (for 5 ms switch-point periodicity)

Table 9.1: Configuration of special subframe (lengths of DwPTS/GP/UpPTS)

Special subframe configuration	Normal cyclic prefix in downlink			Extended cyclic prefix in downlink		
	DwPTS	UpPTS		DwPTS	UpPTS	
		Normal cyclic prefix in uplink	Extended cyclic prefix in uplink		Normal cyclic prefix in uplink	Extended cyclic prefix in uplink
0	$6592 \cdot T_s$	$2192 \cdot T_s$	$2560 \cdot T_s$	$7680 \cdot T_s$	$2192 \cdot T_s$	$2560 \cdot T_s$
1	$19760 \cdot T_s$			$20480 \cdot T_s$		
2	$21952 \cdot T_s$			$23040 \cdot T_s$		
3	$24144 \cdot T_s$			$25600 \cdot T_s$		
4	$26336 \cdot T_s$			$7680 \cdot T_s$		
5	$6592 \cdot T_s$	$4384 \cdot T_s$	$5120 \cdot T_s$	$20480 \cdot T_s$	$4384 \cdot T_s$	$5120 \cdot T_s$
6	$19760 \cdot T_s$			$23040 \cdot T_s$		
7	$21952 \cdot T_s$			$12800 \cdot T_s$		
8	$24144 \cdot T_s$			-		
9	$13168 \cdot T_s$			-		

Table 9.2: Uplink-downlink configurations

Uplink-downlink configuration	Downlink-to-Uplink Switch-point periodicity	Subframe number										
		0	1	2	3	4	5	6	7	8	9	
0	5 ms	D	S	U	U	U	D	S	U	U	U	
1	5 ms	D	S	U	U	D	D	S	U	U	D	
2	5 ms	D	S	U	D	D	D	S	U	D	D	
3	10 ms	D	S	U	U	U	D	D	D	D	D	
4	10 ms	D	S	U	U	D	D	D	D	D	D	
5	10 ms	D	S	U	D	D	D	D	D	D	D	
6	5 ms	D	S	U	U	U	D	S	U	U	D	

Duty factor is calculated by:

$$\begin{aligned}
 \text{Duty factor} &= \text{uplink frame} \cdot 6 + \text{UpPTS} \cdot 2 / \text{one frame length} \\
 &= (30720 \cdot T_s + 6 + 5120 \cdot T_s \cdot 2) / 307200 \cdot T_s \\
 &= 0.633
 \end{aligned}$$

According to the KDB 447498 D01, SAR should be evaluated at more than 3 frequencies for devices supporting transmit bands wider than 100MHz. Oct.2014 FCC-TCB conference notes (Dec. 2014 rev.) specifies the 5 test channels to use for 3GPP band 41 SAR evaluation.

9.5 Bluetooth & Wi-Fi Measurement Procedures for SAR

Normal network operating configurations are not suitable for measuring the SAR of 802.11 transmitters in general. Unpredictable fluctuations in network traffic and antenna diversity conditions can introduce undesirable variations in SAR results. The SAR for these devices should be measured using chipset based test mode software to ensure that the results are consistent and reliable.

Chipset based test mode software is hardware dependent and generally varies among manufacturers. The device operating parameters established in a test mode for SAR measurements must be identical to those programmed in production units, including output power levels, amplifier gain settings and other RF performance tuning parameters. The test frequencies should correspond to actual channel frequencies defined for domestic use. SAR for devices with switched diversity should be measured with only one antenna transmitting at a time during each SAR measurement, according to a fixed modulation and data rate. The same data pattern should be used for all measurements.

9.6 Power Drift

To control the output power stability during the SAR test, DASY4 system calculates the power drift by measuring the E-field at the same location at the beginning and at the end of the measurement for each test position. These drift values can be found in section14 labeled as: (Power Drift [dB]). This ensures that the power drift during one measurement is within 5%.

10 Area Scan Based 1-g SAR

10.1 Requirement of KDB

According to the KDB447498 D01 v05, when the implementation is based the specific polynomial fit algorithm as presented at the 29th Bioelectromagnetics Society meeting (2007) and the estimated 1-gSAR is ≤ 1.2 W/kg, a zoom scan measurement is not required provided it is also not needed for any other purpose; for example, if the peak SAR location required for simultaneous transmission SAR test exclusion can be determined accurately by the SAR system or manually to discriminate between distinctive peaks and scattered noisy SAR distributions from area scans.

There must not be any warning or alert messages due to various measurement concerns identified by the SAR system; for example, noise in measurements, peaks too close to scan boundary, peaks are too sharp, spatial resolution and uncertainty issues etc. The SAR system verification must also demonstrate that the area scan estimated 1-g SAR is within 3% of the zoom scan 1-g SAR (See Annex B). When all the SAR results for each exposure condition in a frequency band and wireless mode are based on estimated 1-g SAR, the 1-g SAR for the highest SAR configuration must be determined by a zoom scan.

10.2 Fast SAR Algorithms

The approach is based on the area scan measurement applying a frequency dependent attenuation parameter. This attenuation parameter was empirically determined by analyzing a large number of phones. The MOTOROLA FAST SAR was developed and validated by the MOTOROLA Research Group in Ft. Lauderdale.

In the initial study, an approximation algorithm based on Linear fit was developed. The accuracy of the algorithm has been demonstrated across a broad frequency range (136-2450 MHz) and for both 1- and 10-g averaged SAR using a sample of 264 SAR measurements from 55 wireless handsets. For the sample size studied, the root-mean-squared errors of the algorithm are 1.2% and 5.8% for 1- and 10-g averaged SAR, respectively. The paper describing the algorithm in detail is expected to be published in August 2004 within the Special Issue of Transactions on MTT.

In the second step, the same research group optimized the fitting algorithm to an Polynomial fit whereby the frequency validity was extended to cover the range 30-6000MHz. Details of this study can be found in the BEMS 2007 Proceedings.

Both algorithms are implemented in DASY software.

11 Conducted Output Power

For Second Antenna, there are two sets of tune-up power, Normal power, Low power for GSM850/WCDMA850/WCDMA1700/WCDMA1900/LTE B2/LTE B4/LTE B5/LTE B7/ LTE B38 under status of receiver on;

Table: Summary of Receiver detection mechanism

Antenna	Normal Power	Receiver on
second ant	Power Level A1	Power Level D1

For Main Antenna, there are three sets of tune-up power, Normal power, Low power for GSM1900/WCDMA1700/WCDMA1900/LTE B2/LTE B4/LTE B 7 under status of sensor on; Low power for GSM1900/WCDMA1700/WCDMA1900/LTE B2/LTE B4/LTE B 7/38 under status of hotspot on;

Table: Summary of Receiver detection mechanism

Antenna	Normal Power	Sensor	Hotspot on
main ant	Power Level A2	Power Level B2	Power Level C2

11.1 GSM Measurement result

During the process of testing, the EUT was controlled via Agilent Digital Radio Communication tester (E5515C) to ensure the maximum power transmission and proper modulation. This result contains conducted output power for the EUT. In all cases, the measured peak output power should be greater and within 5% than EMI measurement.

Table 11.1-1: The conducted power measurement results for 2G - Level A1/A2

GSM 850 Speech (GMSK)	Measured Power (dBm)			Tune up	calculation	Averaged Power (dBm)		
	251	190	128			251	190	128
1 Txslot	32.04	32.64	32.40	33.50	/	/	/	/
GSM 850 GPRS (GMSK)	Measured Power (dBm)				calculation	Averaged Power (dBm)		
	251	190	128			251	190	128
1 Txslot	32.15	32.58	32.30	33.50	-9.03	23.12	23.55	23.27
2 Txslots	29.11	29.41	29.06	30.50	-6.02	23.09	23.39	23.04
3Txslots	26.74	27.64	26.55	28.50	-4.26	22.48	23.38	22.29
4 Txslots	25.06	26.16	24.86	26.50	-3.01	22.05	23.15	21.85
GSM 850 EGPRS (GMSK)	Measured Power (dBm)				calculation	Averaged Power (dBm)		
	251	190	128			251	190	128
1 Txslot	32.21	32.62	32.34	33.50	-9.03	23.18	23.59	23.31
2 Txslots	29.16	29.45	29.12	30.50	-6.02	23.14	23.43	23.10
3Txslots	26.79	27.61	26.57	28.50	-4.26	22.53	23.35	22.31
4 Txslots	25.17	26.22	24.92	26.50	-3.01	22.16	23.21	21.91
GSM 850 EGPRS (8PSK)	Measured Power (dBm)				calculation	Averaged Power (dBm)		
	251	190	128			251	190	128

1 Txslot	26.32	26.56	26.01	27.50	-9.03	17.29	17.53	16.98
2 Txslots	23.27	23.14	23.01	25.00	-6.02	17.25	17.12	16.99
3Txslots	21.32	21.50	20.21	23.20	-4.26	17.06	17.24	15.95
4 Txslots	19.95	20.03	19.53	21.50	-3.01	16.94	17.02	16.52
PCS1900 Speech (GMSK)	Measured Power (dBm)			Tune up	calculation	Averaged Power (dBm)		
	810	661	512			810	661	512
1 Txslot	29.51	29.53	29.51	30.50	/	/	/	/
PCS1900 GPRS (GMSK)	Measured Power (dBm)				calculation	Averaged Power (dBm)		
	810	661	512			810	661	512
1 Txslot	29.13	29.08	29.20	30.50	-9.03	20.10	20.05	20.17
2 Txslots	26.26	26.31	26.26	27.50	-6.02	20.24	20.29	20.24
3Txslots	23.89	24.31	23.78	25.70	-4.26	19.63	20.05	19.52
4 Txslots	22.76	22.47	22.09	24.00	-3.01	19.75	19.46	19.08
PCS1900 EGPRS (GMSK)	Measured Power (dBm)				calculation	Averaged Power (dBm)		
	810	661	512			810	661	512
1 Txslot	29.37	29.20	29.29	30.50	-9.03	20.34	20.17	20.26
2 Txslots	26.38	26.47	26.43	27.50	-6.02	20.36	20.45	20.41
3Txslots	24.07	24.51	23.73	25.70	-4.26	19.81	20.25	19.47
4 Txslots	22.97	22.78	22.12	24.00	-3.01	19.96	19.77	19.11
PCS1900 EGPRS (8PSK)	Measured Power (dBm)				calculation	Averaged Power (dBm)		
	810	661	512			810	661	512
1 Txslot	26.17	25.86	25.81	26.50	-9.03	17.14	16.83	16.78
2 Txslots	22.32	22.16	22.07	24.00	-6.02	16.30	16.14	16.05
3Txslots	21.09	20.98	21.20	22.20	-4.26	16.83	16.72	16.94
4 Txslots	19.32	19.18	19.19	20.50	-3.01	16.31	16.17	16.18

NOTES:

1) Division Factors

To average the power, the division factor is as follows:

1TX-slot = 1 transmit time slot out of 8 time slots=> conducted power divided by (8/1) => -9.03dB

2TX-slots = 2 transmit time slots out of 8 time slots=> conducted power divided by (8/2) => -6.02dB

3TX-slots = 3 transmit time slots out of 8 time slots=> conducted power divided by (8/3) => -4.26dB

4TX-slots = 4 transmit time slots out of 8 time slots=> conducted power divided by (8/4) => -3.01dB

According to the conducted power as above, the body measurements are performed with 1Txslots for GSM850 and 2Txslots GSM1900.

Table 11.1-2: The conducted power measurement results for 2G - Level B2

PCS1900 Speech (GMSK)	Measured Power (dBm)			Tune up	calculation	Averaged Power (dBm)		
	810	661	512			810	661	512
1 Txslot	27.04	27.59	27.61	28.00	/	/	/	/
PCS1900 GPRS (GMSK)	Measured Power (dBm)				calculation	Averaged Power (dBm)		
	810	661	512			810	661	512
1 Txslot	27.15	27.44	27.37	28.00	-9.03	18.12	18.41	18.34

2 Txslots	23.55	23.82	23.69	25.00	-6.02	17.53	17.80	17.67
3Txslots	21.71	21.99	21.91	23.20	-4.26	17.45	17.73	17.65
4 Txslots	20.30	19.78	20.88	22.00	-3.01	17.29	16.77	17.87
PCS1900 EGPRS (GMSK)	Measured Power (dBm)				calculation	Averaged Power (dBm)		
	810	661	512			810	661	512
1 Txslot	27.07	27.32	27.27	28.00	-9.03	18.04	18.29	18.24
2 Txslots	23.46	23.70	23.58	25.00	-6.02	17.44	17.68	17.56
3Txslots	21.65	21.88	21.84	23.20	-4.26	17.39	17.62	17.58
4 Txslots	20.13	19.67	20.77	22.00	-3.01	17.12	16.66	17.76
PCS1900 EGPRS (8PSK)	Measured Power (dBm)				calculation	Averaged Power (dBm)		
	810	661	512			810	661	512
1 Txslot	23.33	23.67	23.45	24.50	-9.03	14.30	14.64	14.42
2 Txslots	19.74	19.85	19.86	21.50	-6.02	13.72	13.83	13.84
3Txslots	18.12	17.95	17.81	19.70	-4.26	13.86	13.69	13.55
4 Txslots	16.68	17.03	17.10	18.50	-3.01	13.67	14.02	14.09

NOTES:

1) Division Factors

To average the power, the division factor is as follows:

1TX-slot = 1 transmit time slot out of 8 time slots=> conducted power divided by (8/1) => -9.03dB

2TX-slots = 2 transmit time slots out of 8 time slots=> conducted power divided by (8/2) => -6.02dB

3TX-slots = 3 transmit time slots out of 8 time slots=> conducted power divided by (8/3) => -4.26dB

4TX-slots = 4 transmit time slots out of 8 time slots=> conducted power divided by (8/4) => -3.01dB

According to the conducted power as above, the body measurements are performed with 1Txslots for GSM1900.

Table 11.1-3: The conducted power measurement results for 2G - Level C2

PCS1900 Speech (GMSK)	Measured Power (dBm)			Tune up	calculation	Averaged Power (dBm)		
	810	661	512			810	661	512
1 Txslot	27.02	27.44	27.52	28.00	/	/	/	/
PCS1900 GPRS (GMSK)	Measured Power (dBm)				calculation	Averaged Power (dBm)		
	810	661	512			810	661	512
1 Txslot	27.09	27.28	27.27	28.00	-9.03	18.06	18.25	18.24
2 Txslots	23.74	23.83	23.78	25.00	-6.02	17.72	17.81	17.76
3Txslots	21.82	21.99	21.99	23.20	-4.26	17.56	17.73	17.73
4 Txslots	20.55	20.06	20.89	22.00	-3.01	17.54	17.05	17.88
PCS1900 EGPRS (GMSK)	Measured Power (dBm)				calculation	Averaged Power (dBm)		
	810	661	512			810	661	512
1 Txslot	27.22	27.41	27.37	28.00	-9.03	18.19	18.38	18.34
2 Txslots	23.88	23.98	23.90	25.00	-6.02	17.86	17.96	17.88
3Txslots	21.97	22.14	22.12	23.20	-4.26	17.71	17.88	17.86
4 Txslots	20.71	20.11	21.01	22.00	-3.01	17.70	17.10	18.00

PCS1900 EGPRS (8PSK)	Measured Power (dBm)				calculation	Averaged Power (dBm)		
	810	661	512			810	661	512
1 Txslot	23.23	23.28	23.11	24.50	-9.03	14.20	14.25	14.08
2 Txslots	19.68	19.78	19.70	21.50	-6.02	13.66	13.76	13.68
3Txslots	17.92	17.68	17.85	19.70	-4.26	13.66	13.42	13.59
4 Txslots	16.69	16.99	16.67	18.50	-3.01	13.68	13.98	13.66

NOTES:

1) Division Factors

To average the power, the division factor is as follows:

1TX-slot = 1 transmit time slot out of 8 time slots=> conducted power divided by (8/1) => -9.03dB

2TX-slots = 2 transmit time slots out of 8 time slots=> conducted power divided by (8/2) => -6.02dB

3TX-slots = 3 transmit time slots out of 8 time slots=> conducted power divided by (8/3) => -4.26dB

4TX-slots = 4 transmit time slots out of 8 time slots=> conducted power divided by (8/4) => -3.01dB

According to the conducted power as above, the body measurements are performed with 1Txslots for GSM1900.

Table 11.1-1: The conducted power measurement results for 2G - Level D1

GSM 850 Speech (GMSK)	Measured Power (dBm)			Tune up	calculation	Averaged Power (dBm)		
	251	190	128			251	190	128
1 Txslot	28.87	28.72	28.79	30.50	/	/	/	/
GSM 850 GPRS (GMSK)	Measured Power (dBm)				calculation	Averaged Power (dBm)		
	251	190	128			251	190	128
1 Txslot	29.04	28.69	28.78	30.50	-9.03	20.01	19.66	19.75
2 Txslots	25.58	25.73	25.63	27.50	-6.02	19.56	19.71	19.61
3Txslots	23.79	23.96	23.78	25.70	-4.26	19.53	19.70	19.52
4 Txslots	22.60	22.67	22.54	24.50	-3.01	19.59	19.66	19.53
GSM 850 EGPRS (GMSK)	Measured Power (dBm)				calculation	Averaged Power (dBm)		
	251	190	128			251	190	128
1 Txslot	28.92	28.69	28.75	30.50	-9.03	19.89	19.66	19.72
2 Txslots	25.50	25.66	25.60	27.50	-6.02	19.48	19.64	19.58
3Txslots	23.72	23.91	23.76	25.70	-4.26	19.46	19.65	19.50
4 Txslots	22.54	22.64	22.52	24.50	-3.01	19.53	19.63	19.51
GSM 850 EGPRS (8PSK)	Measured Power (dBm)				calculation	Averaged Power (dBm)		
	251	190	128			251	190	128
1 Txslot	22.65	22.84	22.63	24.50	-9.03	13.62	13.81	13.60
2 Txslots	19.47	19.67	19.67	21.50	-6.02	13.45	13.65	13.65
3Txslots	18.84	17.95	17.81	19.70	-4.26	14.58	13.69	13.55
4 Txslots	16.61	16.74	17.67	18.50	-3.01	13.60	13.73	14.66

NOTES:

1) Division Factors

To average the power, the division factor is as follows:

1TX-slot = 1 transmit time slot out of 8 time slots=> conducted power divided by (8/1) => -9.03dB
 2TX-slots = 2 transmit time slots out of 8 time slots=> conducted power divided by (8/2) => -6.02dB
 3TX-slots = 3 transmit time slots out of 8 time slots=> conducted power divided by (8/3) => -4.26dB
 4TX-slots = 4 transmit time slots out of 8 time slots=> conducted power divided by (8/4) => -3.01dB

According to the conducted power as above, the body measurements are performed with 1Txslots for GSM850.

11.2 WCDMA Measurement result

Table 11.2-1: The conducted Power for WCDMA- Level A1/A2

Item	band	FDDV result			
	ARFCN	4233 (846.6MHz)	4182 (836.4MHz)	4132 (826.4MHz)	Tune up
WCDMA	\	23.94	23.95	23.79	25.00
HSUPA	1	22.82	22.85	22.83	24.00
	2	20.78	20.86	20.89	22.00
	3	21.83	21.86	21.85	23.00
	4	20.84	20.82	20.79	22.00
	5	22.81	22.88	22.79	24.00
DC-HSDPA	1	22.19	22.31	22.27	24.00
	2	22.17	22.33	22.26	24.00
	3	21.73	21.81	21.74	23.50
	4	21.71	21.79	21.73	23.50
Item	band	FDDIV result			
	ARFCN	1513 (1752.6MHz)	1412 (1732.4MHz)	1312 (1712.4MHz)	
WCDMA	\	23.86	23.84	23.64	25.00
HSUPA	1	22.7	22.78	22.71	24.00
	2	20.8	20.71	20.72	22.00
	3	21.83	21.77	21.76	23.00
	4	20.82	20.78	20.73	22.00
	5	22.81	22.77	22.72	24.00
DC-HSDPA	1	22.11	22.12	22.10	24.00
	2	22.1	22.11	22.12	24.00
	3	21.59	21.64	21.61	23.50
	4	21.6	21.61	21.63	23.50
Item	band	FDDII result			
	ARFCN	9538 (1907.6MHz)	9400 (1880MHz)	9262 (1852.4MHz)	Tune up
WCDMA	\	23.76	23.78	23.72	25.00
HSUPA	1	22.69	22.67	22.66	24.00
	2	20.62	20.65	20.64	22.00
	3	21.63	21.66	21.69	23.00
	4	20.65	20.67	20.66	22.00

	5	22.65	22.64	22.68	24.00
DC-HSDPA	1	22.08	22.12	22.14	24.00
	2	22.1	22.17	22.16	24.00
	3	21.61	21.62	21.67	23.50
	4	21.59	21.61	21.66	23.50

Low power

Table 11.2-2: The conducted Power for WCDMA- Level B2

Item	band	FDDIV result			
	ARFCN	1513 (1752.6MHz)	1412(1732.4MHz)	1312 (1712.4MHz)	Tune up
WCDMA	\	19.85	19.83	19.78	21.00
HSUPA	1	18.7	18.78	18.71	20.00
	2	16.8	16.71	16.72	18.00
	3	17.83	17.77	17.76	19.00
	4	16.82	16.78	16.73	18.00
	5	18.81	18.77	18.72	20.00
DC-HSDPA	1	18.21	18.22	18.20	20.00
	2	18.2	18.21	18.22	20.00
	3	17.69	17.74	17.71	19.50
	4	17.7	17.71	17.73	19.50
Item	band	FDDII result			
	ARFCN	9538 (1907.6MHz)	9400 (1880MHz)	9262 (1852.4MHz)	Tune up
WCDMA	\	19.75	19.84	19.72	21.00
HSUPA	1	18.64	18.62	18.61	20.00
	2	16.57	16.60	16.59	18.00
	3	17.58	17.61	17.64	19.00
	4	16.6	16.62	16.61	18.00
	5	18.6	18.59	18.63	20.00
DC-HSDPA	1	18.03	18.07	18.09	20.00
	2	18.05	18.12	18.11	20.00
	3	17.56	17.57	17.62	19.50
	4	17.54	17.56	17.61	19.50

Table 11.2-3: The conducted Power for WCDMA- Level C2

Item	band	FDDIV result			
	ARFCN	1513 (1752.6MHz)	1412(1732.4MHz)	1312 (1712.4MHz)	Tune up
WCDMA	\	17.36	17.31	17.23	18.50
HSUPA	1	16.2	16.28	16.21	17.50
	2	14.3	14.21	14.22	15.50
	3	15.33	15.27	15.26	16.50
	4	14.32	14.28	14.23	15.50

	5	16.31	16.27	16.22	17.50
DC-HSDPA	1	15.61	15.62	15.60	17.50
	2	15.6	15.61	15.62	17.50
	3	15.09	15.14	15.11	17.00
	4	15.1	15.11	15.13	17.00
Item	band	FDDII result			
	ARFCN	9538 (1907.6MHz)	9400 (1880MHz)	9262 (1852.4MHz)	Tune up
WCDMA	\	16.82	16.79	16.83	18.00
HSUPA	1	15.82	15.80	15.79	17.00
	2	13.75	13.78	13.77	15.00
	3	14.76	14.79	14.82	16.00
	4	13.78	13.80	13.79	15.00
	5	15.78	15.77	15.81	17.00
DC-HSDPA	1	15.41	15.45	15.47	17.00
	2	15.43	15.50	15.49	17.00
	3	14.94	14.95	15.00	16.50
	4	14.92	14.94	14.99	16.50

Table 11.2-1: The conducted Power for WCDMA- Level D1

Item	band	FDDV result			
	ARFCN	4233 (846.6MHz)	4182 (836.4MHz)	4132 (826.4MHz)	Tune up
WCDMA	\	18.43	18.46	18.49	20.00
HSUPA	1	18.87	18.90	18.88	19.00
	2	16.83	16.91	16.94	17.00
	3	17.88	17.91	17.90	18.00
	4	16.89	16.87	16.84	17.00
	5	18.86	18.93	18.84	19.00
DC-HSDPA	1	17.94	18.06	18.02	19.00
	2	17.92	18.08	18.01	19.00
	3	17.48	17.56	17.49	18.50
	4	17.46	17.54	17.48	18.50
Item	band	FDDIV result			
	ARFCN	1513 (1752.6MHz)	1412 (1732.4MHz)	1312 (1712.4MHz)	
WCDMA	\	19.37	19.26	19.14	21.00
HSUPA	1	19.23	19.31	19.24	20.00
	2	17.33	17.24	17.25	18.00
	3	18.36	18.30	18.29	19.00
	4	17.35	17.31	17.26	18.00
	5	19.34	19.30	19.25	20.00
DC-HSDPA	1	18.44	18.45	18.43	20.00
	2	18.43	18.44	18.45	20.00
	3	17.92	17.97	17.94	19.50

Item	4	17.93	17.94	17.96	19.50
	band	FDDII result			
	ARFCN	9538 (1907.6MHz)	9400 (1880MHz)	9262 (1852.4MHz)	Tune up
WCDMA	\	19.04	19.01	18.83	20.50
HSUPA	1	19.19	19.17	19.16	19.50
	2	17.12	17.15	17.14	17.50
	3	18.13	18.16	18.19	18.50
	4	17.15	17.17	17.16	17.50
	5	19.15	19.14	19.18	19.50
DC-HSDPA	1	18.28	18.32	18.34	19.50
	2	18.3	18.37	18.36	19.50
	3	17.81	17.82	17.87	19.00
	4	17.79	17.81	17.86	19.00

11.4 LTE Measurement result

Table 11.4-1: Maximum Power Reduction (MPR) for LTE

Modulation	Channel bandwidth / Transmission bandwidth configuration [RB]						MPR (dB)
	1.4	3	5	10	15	20	
	MHz	MHz	MHz	MHz	MHz	MHz	
QPSK	> 5	> 4	> 8	> 12	> 16	> 18	1
16 QAM	≤ 5	≤ 4	≤ 8	≤ 12	≤ 16	≤ 18	1
16 QAM	> 5	> 4	> 8	> 12	> 16	> 18	2

Table 11.4-2: The tune up for LTE – Level A1/A2

Band	Tune up
LTE Band 2	24
LTE Band 4	24
LTE Band 5	24
LTE Band 38	24

Table 11.4-3: The tune up for LTE – Level A1

Band	Tune up
LTE Band 7	22

Table 11.4-4: The tune up for LTE – Level A2

Band	Tune up
LTE Band 7	24

Table 11.4-5: The tune up for LTE –Level B2

Band	Tune up
LTE Band 2	21

LTE Band 4	21.5
LTE Band 7	21

Table 11.4-6: The tune up for LTE – Level C2

Band	Tune up
LTE Band 2	18
LTE Band 4	18.5
LTE Band 7	21
LTE Band 38	23

Table 11.4-7: The tune up for LTE – Level D1

Band	Tune up
LTE Band 2	20.5
LTE Band 4	20.5
LTE Band 5	20
LTE Band 7	19.5
LTE Band 38	19.5

Table 11.4-8: The conducted Power for LTE- Level A1/A2

Band 2						
Bandwidth (MHz)	RB allocation RB offset (Start RB)	Frequency (MHz)	QPSK	16QAM	64QAM	256QAM
			Actual output power (dBm)	Actual output power (dBm)	Actual output power (dBm)	Actual output power (dBm)
1.4 MHz	1RB High (5)	1909.3	22.37	21.60	20.63	17.49
		1880	22.41	21.77	20.80	17.66
		1850.7	22.41	21.47	20.50	17.36
	1RB Middle (3)	1909.3	22.47	21.60	20.63	17.49
		1880	22.45	21.86	20.89	17.75
		1850.7	22.46	21.53	20.56	17.42
	1RB Low (0)	1909.3	22.44	21.52	20.55	17.41
		1880	22.33	21.79	20.82	17.68
		1850.7	22.37	21.47	20.50	17.36
	3RB High (3)	1909.3	22.37	21.53	20.56	17.42
		1880	22.40	21.65	20.68	17.54
		1850.7	22.38	21.66	20.69	17.55
	3RB Middle (1)	1909.3	22.38	21.54	20.57	17.43
		1880	22.43	21.68	20.71	17.57
		1850.7	22.43	21.65	20.68	17.54
	3RB Low (0)	1909.3	22.34	21.46	20.49	17.35
		1880	22.37	21.62	20.65	17.51
		1850.7	22.36	21.60	20.63	17.49
	6RB (0)	1909.3	21.45	20.57	19.60	17.46
		1880	21.44	20.35	19.38	17.24
		1850.7	21.46	20.62	19.65	17.51

3 MHz	1RB High (14)	1908.5	22.50	21.40	20.43	17.01
		1880	22.54	21.92	20.95	17.53
		1851.5	22.49	21.57	20.60	17.18
	1RB Middle (7)	1908.5	22.40	21.32	20.35	17.33
		1880	22.49	21.84	20.87	17.45
		1851.5	22.42	21.49	20.52	17.10
	1RB Low (0)	1908.5	22.39	21.35	20.38	17.26
		1880	22.44	21.82	20.85	17.43
		1851.5	22.44	21.56	20.59	17.17
	8RB High (7)	1908.5	21.54	20.66	19.69	17.41
		1880	21.51	20.62	19.65	17.37
		1851.5	21.55	20.61	19.64	17.36
	8RB Middle (4)	1908.5	21.54	20.65	19.68	17.40
		1880	21.54	20.62	19.65	17.37
		1851.5	21.57	20.63	19.66	17.38
	8RB Low (0)	1908.5	21.52	20.61	19.64	17.36
		1880	21.48	20.61	19.64	17.36
		1851.5	21.51	20.61	19.64	17.36
15RB (0)	1908.5	21.55	20.58	19.61	17.33	
	1880	21.53	20.59	19.62	17.34	
	1851.5	21.54	20.53	19.56	17.28	
5 MHz	1RB High (24)	1907.5	22.63	21.75	20.78	17.67
		1880	22.55	22.09	21.12	18.01
		1852.5	22.58	21.72	20.75	17.64
	1RB Middle (12)	1907.5	22.53	21.64	20.67	17.56
		1880	22.52	21.97	21.00	17.89
		1852.5	22.50	21.57	20.60	17.49
	1RB Low (0)	1907.5	22.47	21.60	20.63	17.52
		1880	22.42	21.96	20.99	17.88
		1852.5	22.48	21.56	20.59	17.48
	12RB High (13)	1907.5	21.57	20.66	19.69	17.29
		1880	21.60	20.73	19.76	17.36
		1852.5	21.57	20.69	19.72	17.32
	12RB Middle (6)	1907.5	21.58	20.65	19.68	17.28
		1880	21.56	20.73	19.76	17.36
		1852.5	21.63	20.67	19.70	17.30
	12RB Low (0)	1907.5	21.45	20.54	19.57	17.17
		1880	21.50	20.69	19.72	17.32
		1852.5	21.49	20.58	19.61	17.21
25RB (0)	1907.5	21.47	20.51	19.54	17.14	
	1880	21.57	20.60	19.63	17.23	
	1852.5	21.58	20.54	19.57	17.17	
10 MHz	1RB High (49)	1905	22.46	21.61	20.64	17.21
		1880	22.49	21.93	20.96	17.53
		1855	22.40	21.57	20.60	17.17
	1RB Middle (24)	1905	22.38	21.48	20.51	17.08
		1880	22.41	21.93	20.96	17.53
		1855	22.44	21.55	20.58	17.15

	1RB Low (0)	1905	22.49	21.52	20.55	17.12	
		1880	22.48	21.89	20.92	17.49	
		1855	22.36	21.54	20.57	17.14	
	25RB High (25)	1905	21.56	20.60	19.63	17.22	
		1880	21.56	20.63	19.66	17.25	
		1855	21.62	20.73	19.76	17.35	
	25RB Middle (12)	1905	21.60	20.59	19.62	17.21	
		1880	21.56	20.61	19.64	17.23	
		1855	21.63	20.72	19.75	17.34	
	25RB Low (0)	1905	21.56	20.60	19.63	17.22	
		1880	21.49	20.54	19.57	17.16	
		1855	21.46	20.62	19.65	17.24	
	50RB (0)	1905	21.56	20.52	19.55	17.14	
		1880	21.59	20.62	19.65	17.24	
		1855	21.62	20.65	19.68	17.27	
15 MHz	1RB High (74)	1902.5	22.59	21.69	20.72	17.39	
		1880	22.71	22.11	21.14	17.61	
		1857.5	22.71	22.14	21.17	17.64	
	1RB Middle (37)	1902.5	22.68	21.69	20.72	17.19	
		1880	22.69	22.09	21.12	17.59	
		1857.5	22.78	22.15	21.18	17.65	
	1RB Low (0)	1902.5	22.69	21.74	20.77	17.24	
		1880	22.71	22.16	21.19	17.66	
		1857.5	22.76	21.99	21.02	17.49	
	36RB High (38)	1902.5	21.73	20.72	19.75	17.53	
		1880	21.80	20.84	19.87	17.65	
		1857.5	21.83	20.83	19.86	17.64	
	36RB Middle (19)	1902.5	21.81	20.81	19.84	17.62	
		1880	21.80	20.88	19.91	17.69	
		1857.5	21.80	20.81	19.84	17.62	
	36RB Low (0)	1902.5	21.76	20.79	19.82	17.60	
		1880	21.68	20.74	19.77	17.55	
		1857.5	21.70	20.68	19.71	17.49	
	75RB (0)	1902.5	21.78	20.78	19.81	17.59	
		1880	21.75	20.81	19.84	17.62	
		1857.5	21.78	20.79	19.82	17.60	
	20 MHz	1RB High (99)	1900	22.69	22.35	21.38	17.86
			1880	22.68	22.37	21.40	17.88
			1860	22.61	22.14	21.17	17.65
1RB Middle (50)		1900	22.68	22.24	21.27	17.75	
		1880	22.63	22.30	21.33	17.81	
		1860	22.67	22.11	21.14	17.62	
1RB Low (0)		1900	22.68	22.23	21.26	17.74	
		1880	22.65	22.40	21.43	17.91	
		1860	22.68	22.16	21.19	17.67	
50RB High (50)		1900	21.73	20.76	19.79	17.50	
		1880	21.81	20.82	19.85	17.56	
		1860	21.79	20.79	19.82	17.53	

	50RB Middle (25)	1900	21.77	20.81	19.84	17.55
		1880	21.81	20.83	19.86	17.57
		1860	21.83	20.81	19.84	17.55
	50RB Low (0)	1900	21.72	20.76	19.79	17.50
		1880	21.72	20.75	19.78	17.49
		1860	21.72	20.69	19.72	17.43
	100RB (0)	1900	21.77	20.82	19.85	17.56
		1880	21.76	20.77	19.80	17.51
		1860	21.80	20.81	19.84	17.55

Band 4							
Bandwidth (MHz)	RB allocation	Frequency (MHz)	QPSK	16QAM	64QAM	256QAM	
	RB offset (Start RB)		Actual output power (dBm)	Actual output power (dBm)	Actual output power (dBm)	Actual output power (dBm)	
1.4 MHz	1RB High (5)	1754.3	22.41	22.24	20.71	17.91	
		1732.5	22.48	21.57	20.09	17.24	
		1710.7	22.43	21.70	20.21	17.37	
	1RB Middle (3)	1754.3	22.43	22.30	20.77	17.97	
		1732.5	22.34	21.63	20.15	17.30	
		1710.7	22.50	21.78	20.28	17.45	
	1RB Low (0)	1754.3	22.42	22.26	20.73	17.93	
		1732.5	22.39	21.48	20.01	17.15	
		1710.7	22.44	21.70	20.21	17.37	
	3RB High (3)	1754.3	22.42	22.09	20.57	17.76	
		1732.5	22.46	21.74	20.25	17.41	
		1710.7	22.47	21.65	20.16	17.32	
	3RB Middle (1)	1754.3	22.46	22.17	20.65	17.84	
		1732.5	22.48	21.75	20.26	17.42	
		1710.7	22.50	21.73	20.24	17.49	
	3RB Low (0)	1754.3	22.44	22.06	20.55	17.82	
		1732.5	22.44	21.71	20.22	17.47	
		1710.7	22.45	21.63	20.15	17.39	
	6RB (0)	1754.3	21.55	20.82	19.39	17.28	
		1732.5	21.52	20.74	19.32	17.16	
		1710.7	21.53	20.83	19.40	17.31	
	3 MHz	1RB High (14)	1753.5	22.98	22.37	20.83	17.53
			1732.5	22.63	21.65	20.16	17.31
			1711.5	22.54	21.47	20.00	17.22
		1RB Middle (7)	1753.5	22.41	22.27	20.74	17.43
			1732.5	22.60	21.60	20.12	17.36
			1711.5	22.43	21.47	20.00	17.25
1RB Low (0)		1753.5	22.41	22.27	20.74	17.43	
		1732.5	22.44	21.56	20.08	17.32	
		1711.5	22.40	21.50	20.02	17.26	
8RB		1753.5	21.69	21.06	19.61	17.48	

	High (7)	1732.5	21.64	20.76	19.33	17.18	
		1711.5	21.62	20.74	19.32	17.16	
	8RB Middle (4)	1753.5	21.66	21.08	19.63	17.50	
		1732.5	21.64	20.70	19.28	17.12	
	8RB Low (0)	1711.5	21.63	20.84	19.41	17.26	
		1753.5	21.57	20.98	19.54	17.40	
		1732.5	21.58	20.62	19.20	17.04	
	15RB (0)	1711.5	21.57	20.83	19.40	17.25	
		1753.5	21.63	20.98	19.54	17.40	
		1732.5	21.63	20.61	19.20	17.03	
	5 MHz	1RB High (24)	1711.5	21.61	20.75	19.33	17.17
			1752.5	22.80	22.20	20.68	17.56
1732.5			22.64	22.23	20.70	17.58	
1RB Middle (12)		1712.5	22.51	21.76	20.27	17.15	
		1752.5	22.76	22.10	20.58	17.46	
		1732.5	22.56	22.12	20.60	17.48	
1RB Low (0)		1712.5	22.58	21.72	20.23	17.11	
		1752.5	22.59	22.03	20.52	17.40	
		1732.5	22.47	22.06	20.55	17.43	
12RB High (13)		1712.5	22.50	21.76	20.27	17.15	
		1752.5	21.91	21.06	19.61	17.45	
		1732.5	21.69	20.85	19.42	17.24	
12RB Middle (6)		1712.5	21.64	20.73	19.31	17.12	
		1752.5	21.81	21.03	19.59	17.42	
		1732.5	21.69	20.85	19.42	17.24	
12RB Low (0)		1712.5	21.75	20.78	19.35	17.17	
		1752.5	21.73	20.97	19.53	17.36	
		1732.5	21.54	20.72	19.30	17.11	
25RB (0)		1712.5	21.73	20.78	19.35	17.17	
		1752.5	21.76	20.97	19.53	17.36	
		1732.5	21.65	20.75	19.32	17.14	
10 MHz		1RB High (49)	1712.5	21.70	20.70	19.28	17.09
			1750	22.88	21.84	20.34	17.60
			1732.5	22.51	22.04	20.53	17.80
	1RB Middle (24)	1715	22.49	21.55	20.07	17.31	
		1750	22.73	21.79	20.29	17.55	
		1732.5	22.44	22.00	20.49	17.76	
	1RB Low (0)	1715	22.63	21.59	20.11	17.35	
		1750	22.63	21.69	20.20	17.45	
		1732.5	22.48	21.96	20.45	17.72	
	25RB High (25)	1715	22.42	21.48	20.01	17.24	
		1750	21.89	21.01	19.57	17.40	
		1732.5	21.68	20.77	19.34	17.16	
	25RB Middle (12)	1715	21.62	20.69	19.27	17.08	
		1750	21.83	20.91	19.47	17.30	
		1732.5	21.70	20.75	19.33	17.14	
	25RB	1715	21.70	20.79	19.36	17.18	
			1750	21.77	20.87	19.44	17.26

	Low (0)	1732.5	21.58	20.62	19.20	17.01	
		1715	21.68	20.78	19.35	17.17	
	50RB (0)	1750	21.82	20.85	19.42	17.24	
		1732.5	21.67	20.71	19.29	17.10	
		1715	21.71	20.72	19.30	17.11	
		1747.5	22.99	22.47	20.93	17.78	
15 MHz	1RB High (74)	1732.5	22.75	21.80	20.30	17.11	
		1717.5	22.71	22.09	20.57	17.40	
		1747.5	22.89	22.39	20.85	17.70	
	1RB Middle (37)	1732.5	22.68	21.74	20.25	17.05	
		1717.5	22.77	22.09	20.57	17.40	
		1747.5	22.95	22.33	20.80	17.64	
	1RB Low (0)	1732.5	22.77	21.85	20.35	17.16	
		1717.5	22.65	22.13	20.61	17.44	
		1747.5	22.09	21.08	19.63	17.63	
	36RB High (38)	1732.5	21.85	20.80	19.37	17.35	
		1717.5	21.66	20.77	19.34	17.32	
		1747.5	22.03	21.04	19.60	17.59	
	36RB Middle (19)	1732.5	21.83	20.87	19.44	17.42	
		1717.5	21.79	20.88	19.45	17.43	
		1747.5	22.04	21.01	19.57	17.56	
	36RB Low (0)	1732.5	21.83	20.76	19.33	17.31	
		1717.5	21.82	20.94	19.50	17.49	
		1747.5	22.02	21.00	19.56	17.55	
	75RB (0)	1732.5	21.83	20.87	19.44	17.42	
		1717.5	21.79	20.90	19.47	17.45	
		1745	23.06	22.58	21.03	17.73	
	20 MHz	1RB High (99)	1732.5	22.83	22.25	20.72	17.40
			1720	22.91	22.32	20.79	17.47
			1745	22.81	22.36	20.83	17.51
1RB Middle (50)		1732.5	22.62	22.12	20.60	17.27	
		1720	22.58	22.19	20.67	17.34	
		1745	22.79	22.32	20.79	17.47	
1RB Low (0)		1732.5	22.65	22.15	20.63	17.30	
		1720	22.57	22.20	20.68	17.35	
		1745	22.11	21.13	19.68	17.59	
50RB High (50)		1732.5	21.78	20.84	19.41	17.30	
		1720	21.74	20.83	19.40	17.29	
		1745	22.06	21.10	19.65	17.56	
50RB Middle (25)		1732.5	21.87	20.84	19.41	17.30	
		1720	21.77	20.87	19.44	17.33	
		1745	21.95	20.99	19.55	17.45	
50RB Low (0)		1732.5	21.81	20.79	19.36	17.25	
		1720	21.86	20.92	19.48	17.38	
		1745	22.03	21.09	19.64	17.55	
100RB (0)		1732.5	21.85	20.85	19.42	17.31	
		1720	21.82	20.85	19.42	17.31	

Band 5							
Bandwidth (MHz)	RB allocation	Frequency (MHz)	QPSK	16QAM	64QAM	256QAM	
	RB offset (Start RB)		Actual output power (dBm)	Actual output power (dBm)	Actual output power (dBm)	Actual output power (dBm)	
1.4 MHz	1RB High (5)	848.3	22.49	21.90	21.39	17.63	
		836.5	22.56	21.59	21.09	17.32	
		824.7	22.42	21.72	21.22	17.45	
	1RB Middle (3)	848.3	22.57	21.98	21.47	17.71	
		836.5	22.63	21.69	21.19	17.42	
		824.7	22.60	21.79	21.29	17.52	
	1RB Low (0)	848.3	22.49	21.96	21.46	17.69	
		836.5	22.55	21.56	21.06	17.29	
		824.7	22.52	21.66	21.16	17.39	
	3RB High (3)	848.3	22.50	21.77	21.27	17.50	
		836.5	22.51	21.77	21.27	17.50	
		824.7	22.51	21.69	21.19	17.42	
	3RB Middle (1)	848.3	22.60	21.90	21.39	17.63	
		836.5	22.55	21.85	21.34	17.58	
		824.7	22.55	21.68	21.18	17.41	
	3RB Low (0)	848.3	22.51	21.81	21.30	17.54	
		836.5	22.48	21.74	21.23	17.47	
		824.7	22.53	21.66	21.16	17.39	
	6RB (0)	848.3	21.54	20.46	19.99	17.22	
		836.5	21.61	20.78	20.30	17.15	
		824.7	21.60	20.74	20.26	17.23	
	3 MHz	1RB High (14)	847.5	22.59	21.51	21.02	17.28
			836.5	22.60	22.03	21.52	17.50
			825.5	22.52	21.66	21.16	17.13
1RB Middle (7)		847.5	22.57	21.64	21.14	17.11	
		836.5	22.60	22.01	21.51	17.48	
		825.5	22.59	21.66	21.16	17.13	
1RB Low (0)		847.5	22.57	21.62	21.13	17.09	
		836.5	22.60	22.07	21.56	17.54	
		825.5	22.57	21.73	21.23	17.20	
8RB High (7)		847.5	21.68	20.75	20.27	17.43	
		836.5	21.72	20.78	20.30	17.46	
		825.5	21.65	20.74	20.26	17.42	
8RB Middle (4)		847.5	21.72	20.81	20.33	17.49	
		836.5	21.72	20.80	20.32	17.48	
		825.5	21.73	20.79	20.31	17.47	
8RB Low (0)		847.5	21.65	20.74	20.26	17.42	
		836.5	21.65	20.74	20.26	17.42	
		825.5	21.68	20.71	20.23	17.39	
15RB (0)		847.5	21.67	20.65	20.18	17.33	
		836.5	21.72	20.76	20.28	17.44	
		825.5	21.73	20.70	20.22	17.38	

5 MHz	1RB High (24)	846.5	22.68	21.86	21.35	17.51	
		836.5	22.74	21.79	21.29	17.44	
		826.5	22.60	22.14	21.63	17.79	
	1RB Middle (12)	846.5	22.64	21.88	21.38	17.53	
		836.5	22.65	21.85	21.35	17.50	
		826.5	22.62	22.16	21.65	17.81	
	1RB Low (0)	846.5	22.77	21.90	21.39	17.55	
		836.5	22.71	21.82	21.32	17.47	
		826.5	22.64	22.18	21.67	17.83	
	12RB High (13)	846.5	21.67	20.76	20.28	17.31	
		836.5	21.75	20.77	20.29	17.32	
		826.5	21.72	20.84	20.36	17.39	
	12RB Middle (6)	846.5	21.74	20.79	20.31	17.34	
		836.5	21.69	20.78	20.30	17.33	
		826.5	21.77	20.91	20.42	17.46	
	12RB Low (0)	846.5	21.78	20.86	20.38	17.41	
		836.5	21.61	20.79	20.31	17.34	
		826.5	21.74	20.89	20.41	17.44	
	25RB (0)	846.5	21.76	20.71	20.23	17.26	
		836.5	21.69	20.73	20.25	17.28	
		826.5	21.76	20.81	20.33	17.36	
	10 MHz	1RB High (49)	844.0	22.57	22.06	21.55	17.98
			836.5	22.45	21.71	21.21	17.63
			829.0	22.63	21.57	21.07	17.49
1RB Middle (24)		844.0	22.62	22.11	21.60	18.03	
		836.5	22.52	21.66	21.16	17.58	
		829.0	22.49	21.52	21.02	17.44	
1RB Low (0)		844.0	22.62	22.10	21.59	18.02	
		836.5	22.48	21.61	21.11	17.53	
		829.0	22.51	21.73	21.23	17.65	
25RB High (25)		844.0	21.70	20.78	20.30	17.43	
		836.5	21.69	20.82	20.34	17.47	
		829.0	21.74	20.77	20.29	17.42	
25RB Middle (12)		844.0	21.68	20.74	20.26	17.39	
		836.5	21.74	20.78	20.30	17.43	
		829.0	21.77	20.80	20.32	17.45	
25RB Low (0)		844.0	21.64	20.69	20.22	17.34	
		836.5	21.66	20.79	20.32	17.44	
		829.0	21.72	20.73	20.25	17.38	
50RB (0)		844.0	21.68	20.73	20.25	17.38	
		836.5	21.61	20.70	20.22	17.35	
		829.0	21.74	20.70	20.22	17.35	

Band 38						
Bandwidth (MHz)	RB allocation	Frequency (MHz)	QPSK	16QAM	64QAM	256QAM
	RB offset (Start RB)		Actual output power (dBm)	Actual output power (dBm)	Actual output power (dBm)	Actual output power (dBm)
5 MHz	1RB High (24)	2617.5	22.61	21.64	20.69	17.30
		2595	22.74	21.72	20.77	17.38
		2572.5	22.64	21.55	20.61	17.21
	1RB Middle (12)	2617.5	22.52	21.57	20.63	17.23
		2595	22.65	21.66	20.71	17.32
		2572.5	22.28	21.47	20.54	17.13
	1RB Low (0)	2617.5	22.47	21.57	20.63	17.23
		2595	22.59	21.58	20.64	17.24
		2572.5	22.23	21.51	20.57	17.17
	12RB High (13)	2617.5	21.72	20.68	19.78	17.50
		2595	21.77	20.72	19.82	17.54
		2572.5	21.35	20.54	19.64	17.36
	12RB Middle (6)	2617.5	21.72	20.74	19.83	17.56
		2595	21.77	20.71	19.80	17.53
		2572.5	21.32	20.58	19.68	17.40
	12RB Low (0)	2617.5	21.64	20.64	19.74	17.46
		2595	21.69	20.61	19.71	17.43
		2572.5	21.32	20.48	19.59	17.30
	25RB (0)	2617.5	21.68	20.68	19.78	17.50
		2595	21.72	20.72	19.82	17.54
		2572.5	21.28	20.48	19.58	17.30
10 MHz	1RB High (49)	2615	22.60	21.66	20.72	17.16
		2595	22.64	21.73	20.78	17.23
		2575	22.50	21.59	20.65	17.09
	1RB Middle (24)	2615	22.59	21.59	20.65	17.09
		2595	22.56	21.64	20.69	17.14
		2575	22.42	21.54	20.60	17.04
	1RB Low (0)	2615	22.53	21.59	20.65	17.09
		2595	22.56	21.69	20.74	17.19
		2575	22.34	21.56	20.62	17.06
	25RB High (25)	2615	21.69	20.74	19.84	17.56
		2595	21.74	20.78	19.87	17.60
		2575	21.57	20.61	19.71	17.43
	25RB Middle (12)	2615	21.72	20.71	19.81	17.53
		2595	21.76	20.75	19.84	17.57
		2575	21.54	20.62	19.72	17.44
	25RB Low (0)	2615	21.72	20.72	19.82	17.54
		2595	21.66	20.65	19.75	17.47
		2575	21.51	20.54	19.65	17.36
	50RB (0)	2615	21.73	20.71	19.81	17.53
		2595	21.77	20.81	19.90	17.63
		2575	21.54	20.56	19.66	17.38

15 MHz	1RB High (74)	2612.5	22.80	21.74	20.79	17.43
		2595	22.93	21.89	20.94	17.58
		2577.5	22.78	21.79	20.84	17.48
	1RB Middle (37)	2612.5	22.76	21.78	20.83	17.47
		2595	22.87	21.89	20.94	17.58
		2577.5	22.76	21.83	20.87	17.52
	1RB Low (0)	2612.5	22.76	21.77	20.82	17.46
		2595	22.80	21.87	20.91	17.56
		2577.5	22.78	21.77	20.82	17.46
	36RB High (38)	2612.5	21.91	20.89	19.98	17.71
		2595	22.01	20.87	19.96	17.69
		2577.5	21.90	20.94	20.02	17.76
	36RB Middle (19)	2612.5	21.87	20.83	19.92	17.65
		2595	21.97	20.92	20.01	17.74
		2577.5	21.89	20.94	20.02	17.76
	36RB Low (0)	2612.5	21.87	20.88	19.97	17.70
		2595	21.87	20.93	20.02	17.75
		2577.5	21.86	20.85	19.94	17.67
75RB (0)	2612.5	21.86	20.84	19.93	17.66	
	2595	21.94	21.03	20.11	17.85	
	2577.5	21.91	20.91	19.99	17.73	
20 MHz	1RB High (99)	2610	22.86	21.74	20.79	17.47
		2595	22.85	22.01	21.05	17.74
		2580	22.83	21.76	20.81	17.49
	1RB Middle (50)	2610	22.79	21.72	20.77	17.45
		2595	22.82	21.96	21.01	17.69
		2580	22.75	21.74	20.79	17.47
	1RB Low (0)	2610	22.85	21.70	20.76	17.43
		2595	22.74	21.97	21.01	17.70
		2580	22.71	21.76	20.81	17.49
	50RB High (50)	2610	21.90	20.95	20.03	17.77
		2595	21.95	21.00	20.09	17.82
		2580	21.90	20.88	19.97	17.70
	50RB Middle (25)	2610	21.93	20.98	20.07	17.80
		2595	21.97	21.01	20.09	17.83
		2580	21.92	20.91	19.99	17.73
	50RB Low (0)	2610	21.88	20.89	19.98	17.71
		2595	21.91	20.94	20.03	17.76
		2580	21.82	20.80	19.89	17.62
100RB (0)	2610	21.95	20.95	20.04	17.77	
	2595	21.99	20.97	20.05	17.79	
	2580	21.92	20.90	19.98	17.72	

Table 11.4-9: The conducted Power for LTE- Level A1

Band 7							
Bandwidth (MHz)	RB allocation	Frequency (MHz)	QPSK	16QAM	64QAM	256QAM	
	RB offset (Start RB)		Actual output power (dBm)	Actual output power (dBm)	Actual output power (dBm)	Actual output power (dBm)	
5 MHz	1RB High (24)	2567.5	20.96	20.18	19.10	16.05	
		2535	20.91	20.45	19.35	16.32	
		2502.5	21.04	20.19	19.10	16.06	
	1RB Middle (12)	2567.5	20.94	20.07	18.99	15.94	
		2535	20.94	20.48	19.37	16.35	
		2502.5	20.99	20.11	19.02	15.98	
	1RB Low (0)	2567.5	20.99	20.15	19.07	16.02	
		2535	20.92	20.43	19.32	16.30	
		2502.5	20.95	20.04	18.96	15.91	
	12RB High (13)	2567.5	20.01	19.14	18.10	15.90	
		2535	19.99	19.17	18.13	15.93	
		2502.5	20.11	19.14	18.10	15.90	
	12RB Middle (6)	2567.5	20.02	19.11	18.07	15.87	
		2535	20.00	19.15	18.12	15.91	
		2502.5	20.11	19.17	18.13	15.93	
	12RB Low (0)	2567.5	20.02	19.11	18.08	15.87	
		2535	19.98	19.15	18.11	15.91	
		2502.5	20.10	19.17	18.13	15.93	
	25RB (0)	2567.5	20.05	19.06	18.03	15.82	
		2535	20.01	19.08	18.04	15.84	
		2502.5	20.11	19.06	18.03	15.82	
	10 MHz	1RB High (49)	2565	20.97	19.75	18.69	16.04
			2535	20.96	20.39	19.29	16.68
			2505	20.83	20.02	18.94	16.31
1RB Middle (24)		2565	20.80	19.96	18.88	16.25	
		2535	20.93	20.36	19.26	16.65	
		2505	20.94	20.02	18.94	16.31	
1RB Low (0)		2565	20.79	19.93	18.85	16.22	
		2535	20.91	20.35	19.26	16.64	
		2505	20.84	19.99	18.91	16.28	
25RB High (25)		2565	20.02	19.07	18.04	15.77	
		2535	19.98	19.05	18.02	15.75	
		2505	20.12	19.20	18.16	15.90	
25RB Middle (12)		2565	20.04	19.08	18.04	15.78	
		2535	20.00	19.01	17.98	15.71	
		2505	20.12	19.26	18.22	15.96	
25RB Low (0)		2565	19.99	19.10	18.07	15.80	
		2535	19.98	18.98	17.96	15.68	
		2505	20.00	19.12	18.08	15.82	
50RB (0)		2565	20.00	19.05	18.02	15.75	
		2535	19.97	19.05	18.02	15.75	

15 MHz	1RB High (74)	2505	20.07	19.14	18.11	15.84
		2562.5	20.83	19.65	18.59	15.35
		2535	21.21	20.58	19.47	16.28
	1RB Middle (37)	2507.5	21.26	20.57	19.46	16.27
		2562.5	21.11	20.23	19.14	15.93
		2535	21.26	20.59	19.48	16.29
	1RB Low (0)	2507.5	21.25	20.75	19.63	16.45
		2562.5	21.07	20.06	18.98	15.76
		2535	21.19	20.61	19.50	16.31
	36RB High (38)	2507.5	21.23	20.66	19.54	16.36
		2562.5	20.16	19.22	18.18	16.05
		2535	20.21	19.26	18.21	16.09
	36RB Middle (19)	2507.5	20.29	19.28	18.23	16.11
		2562.5	20.19	19.20	18.16	16.03
		2535	20.22	19.26	18.22	16.09
	36RB Low (0)	2507.5	20.34	19.33	18.28	16.16
		2562.5	20.14	19.12	18.09	15.95
		2535	20.20	19.25	18.21	16.08
	75RB (0)	2507.5	20.25	19.22	18.18	16.05
		2562.5	20.15	19.19	18.15	16.02
		2535	20.16	19.24	18.19	16.07
20 MHz	1RB High (99)	2507.5	20.29	19.29	18.24	16.12
		2560	20.91	20.28	19.18	15.81
		2535	21.19	20.62	19.51	16.15
	1RB Middle (50)	2510	21.20	20.76	19.64	16.29
		2560	21.10	20.80	19.68	16.33
		2535	21.18	20.61	19.50	16.14
	1RB Low (0)	2510	21.14	20.74	19.62	16.27
		2560	21.09	20.67	19.56	16.20
		2535	21.41	20.55	19.44	16.08
	50RB High (50)	2510	21.25	20.92	19.80	16.45
		2560	20.18	19.21	18.17	15.96
		2535	20.21	19.20	18.16	15.95
	50RB Middle (25)	2510	20.26	19.32	18.27	16.07
		2560	20.17	19.22	18.18	15.97
		2535	20.20	19.21	18.17	15.96
	50RB Low (0)	2510	20.30	19.37	18.32	16.12
		2560	20.11	19.15	18.12	15.90
		2535	20.23	19.19	18.15	15.94
	100RB (0)	2510	20.23	19.27	18.23	16.02
		2560	20.18	19.18	18.14	15.93
		2535	20.22	19.19	18.15	15.94
		2510	20.33	19.36	18.31	16.11

Table 11.4-10: The conducted Power for LTE- Level A2

Band 7							
Bandwidth (MHz)	RB allocation	Frequency (MHz)	QPSK	16QAM	64QAM	256QAM	
	RB offset (Start RB)		Actual output power (dBm)	Actual output power (dBm)	Actual output power (dBm)	Actual output power (dBm)	
5 MHz	1RB High (24)	2567.5	22.66	21.88	20.80	17.45	
		2535	22.61	22.15	21.05	17.72	
		2502.5	22.74	21.89	20.80	17.46	
	1RB Middle (12)	2567.5	22.64	21.77	20.69	17.34	
		2535	22.64	22.18	21.07	17.75	
		2502.5	22.69	21.81	20.72	17.38	
	1RB Low (0)	2567.5	22.69	21.85	20.77	17.42	
		2535	22.62	22.13	21.02	17.70	
		2502.5	22.65	21.74	20.66	17.31	
	12RB High (13)	2567.5	21.71	20.84	19.80	17.30	
		2535	21.69	20.87	19.83	17.33	
		2502.5	21.81	20.84	19.80	17.30	
	12RB Middle (6)	2567.5	21.72	20.81	19.77	17.27	
		2535	21.70	20.85	19.82	17.31	
		2502.5	21.81	20.87	19.83	17.33	
	12RB Low (0)	2567.5	21.72	20.81	19.78	17.27	
		2535	21.68	20.85	19.81	17.31	
		2502.5	21.80	20.87	19.83	17.33	
	25RB (0)	2567.5	21.75	20.76	19.73	17.22	
		2535	21.71	20.78	19.74	17.24	
		2502.5	21.81	20.76	19.73	17.22	
	10 MHz	1RB High (49)	2565	22.67	21.45	20.39	17.44
			2535	22.66	22.09	20.99	18.08
			2505	22.53	21.72	20.64	17.71
1RB Middle (24)		2565	22.50	21.66	20.58	17.65	
		2535	22.63	22.06	20.96	18.05	
		2505	22.64	21.72	20.64	17.71	
1RB Low (0)		2565	22.49	21.63	20.55	17.62	
		2535	22.61	22.05	20.96	18.04	
		2505	22.54	21.69	20.61	17.68	
25RB High (25)		2565	21.72	20.77	19.74	17.17	
		2535	21.68	20.75	19.72	17.15	
		2505	21.82	20.90	19.86	17.30	
25RB Middle (12)		2565	21.74	20.78	19.74	17.18	
		2535	21.70	20.71	19.68	17.11	
		2505	21.82	20.96	19.92	17.36	
25RB Low (0)		2565	21.69	20.80	19.77	17.20	
		2535	21.68	20.68	19.66	17.08	
		2505	21.70	20.82	19.78	17.22	
50RB (0)		2565	21.70	20.75	19.72	17.15	
		2535	21.67	20.75	19.72	17.15	

15 MHz	1RB High (74)	2505	21.77	20.84	19.81	17.24
		2562.5	22.53	21.35	20.29	17.55
		2535	22.91	22.28	21.17	17.68
	1RB Middle (37)	2507.5	22.96	22.27	21.16	17.67
		2562.5	22.81	21.93	20.84	17.33
		2535	22.96	22.29	21.18	17.69
	1RB Low (0)	2507.5	22.95	22.45	21.33	17.85
		2562.5	22.77	21.76	20.68	17.16
		2535	22.89	22.31	21.20	17.71
	36RB High (38)	2507.5	22.93	22.36	21.24	17.76
		2562.5	21.86	20.92	19.88	17.45
		2535	21.91	20.96	19.91	17.49
	36RB Middle (19)	2507.5	21.99	20.98	19.93	17.51
		2562.5	21.89	20.90	19.86	17.43
		2535	21.92	20.96	19.92	17.49
	36RB Low (0)	2507.5	22.04	21.03	19.98	17.56
		2562.5	21.84	20.82	19.79	17.35
		2535	21.90	20.95	19.91	17.48
	75RB (0)	2507.5	21.95	20.92	19.88	17.45
		2562.5	21.85	20.89	19.85	17.42
		2535	21.86	20.94	19.89	17.47
20 MHz	1RB High (99)	2507.5	21.99	20.99	19.94	17.52
		2560	22.61	21.98	20.88	17.21
		2535	22.89	22.32	21.21	17.55
	1RB Middle (50)	2510	22.90	22.46	21.34	17.69
		2560	22.80	22.50	21.38	17.73
		2535	22.88	22.31	21.20	17.54
	1RB Low (0)	2510	22.84	22.44	21.32	17.67
		2560	22.79	22.37	21.26	17.60
		2535	22.92	22.25	21.14	17.48
	50RB High (50)	2510	22.89	22.62	21.50	17.85
		2560	21.88	20.91	19.87	17.36
		2535	21.91	20.90	19.86	17.35
	50RB Middle (25)	2510	21.96	21.02	19.97	17.47
		2560	21.87	20.92	19.88	17.37
		2535	21.90	20.91	19.87	17.36
	50RB Low (0)	2510	22.00	21.07	20.02	17.52
		2560	21.81	20.85	19.82	17.30
		2535	21.93	20.89	19.85	17.34
	100RB (0)	2510	21.93	20.97	19.93	17.42
		2560	21.88	20.88	19.84	17.33
		2535	21.92	20.89	19.85	17.34
		2510	22.03	21.06	20.01	17.51

Table 11.4-12: The conducted Power for LTE-Level B2

Band 2							
Bandwidth (MHz)	RB allocation	Frequency (MHz)	QPSK	16QAM	64QAM	256QAM	
	RB offset (Start RB)		Actual output power (dBm)	Actual output power (dBm)	Actual output power (dBm)	Actual output power (dBm)	
1.4 MHz	1RB High (5)	1909.3	19.37	19.51	19.81	17.22	
		1880	19.44	19.61	19.92	17.32	
		1850.7	19.46	19.81	20.12	17.52	
	1RB Middle (3)	1909.3	19.45	19.57	19.87	17.28	
		1880	19.52	19.67	19.98	17.38	
		1850.7	19.51	19.86	20.17	17.57	
	1RB Low (0)	1909.3	19.36	19.44	19.74	17.15	
		1880	19.44	19.56	19.86	17.27	
		1850.7	19.40	19.83	20.14	17.54	
	3RB High (3)	1909.3	19.41	19.67	19.98	17.38	
		1880	19.39	19.54	19.84	17.25	
		1850.7	19.43	19.67	19.98	17.38	
	3RB Middle (1)	1909.3	19.44	19.71	20.02	17.42	
		1880	19.44	19.54	19.84	17.25	
		1850.7	19.48	19.75	20.06	17.46	
	3RB Low (0)	1909.3	19.36	19.64	19.95	17.35	
		1880	19.37	19.49	19.79	17.20	
		1850.7	19.44	19.65	19.96	17.36	
	6RB (0)	1909.3	19.46	19.64	19.95	17.35	
		1880	19.45	19.62	19.93	17.33	
		1850.7	19.47	19.40	19.70	17.11	
	3 MHz	1RB High (14)	1908.5	19.46	19.58	19.89	17.29
			1880	19.50	19.43	19.73	17.14
			1851.5	19.51	19.97	20.28	17.68
		1RB Middle (7)	1908.5	19.39	19.51	19.81	17.22
			1880	19.41	19.36	19.66	17.07
			1851.5	19.46	19.89	20.20	17.60
1RB Low (0)		1908.5	19.47	19.59	19.90	17.30	
		1880	19.38	19.40	19.70	17.11	
		1851.5	19.50	19.93	20.24	17.64	
8RB High (7)		1908.5	19.56	19.61	19.92	17.32	
		1880	19.57	19.68	19.99	17.39	
		1851.5	19.57	19.65	19.96	17.36	
8RB Middle (4)		1908.5	19.55	19.64	19.95	17.35	
		1880	19.60	19.68	19.99	17.39	
		1851.5	19.56	19.65	19.96	17.36	
8RB Low (0)		1908.5	19.57	19.61	19.92	17.32	
		1880	19.53	19.67	19.98	17.38	
		1851.5	19.54	19.63	19.94	17.34	
15RB (0)		1908.5	19.60	19.53	19.83	17.24	
		1880	19.59	19.59	19.90	17.30	

5 MHz	1RB High (24)	1851.5	19.58	19.62	19.93	17.33
		1907.5	19.57	19.75	20.06	17.46
		1880	19.61	19.82	20.13	17.53
		1852.5	19.53	20.14	20.45	17.85
	1RB Middle (12)	1907.5	19.47	19.62	19.93	17.33
		1880	19.51	19.69	20.00	17.40
		1852.5	19.54	20.00	20.31	17.71
	1RB Low (0)	1907.5	19.44	19.60	19.91	17.31
		1880	19.55	19.70	20.01	17.41
		1852.5	19.43	19.94	20.25	17.65
	12RB High (13)	1907.5	19.56	19.64	19.95	17.35
		1880	19.56	19.66	19.97	17.37
		1852.5	19.61	19.79	20.10	17.50
	12RB Middle (6)	1907.5	19.60	19.67	19.98	17.38
		1880	19.60	19.70	20.01	17.41
		1852.5	19.60	19.75	20.06	17.46
	12RB Low (0)	1907.5	19.47	19.59	19.90	17.30
		1880	19.53	19.63	19.94	17.34
		1852.5	19.52	19.67	19.98	17.38
	25RB (0)	1907.5	19.51	19.51	19.81	17.22
		1880	19.64	19.63	19.94	17.34
1852.5		19.57	19.67	19.98	17.38	
10 MHz	1RB High (49)	1905	19.35	19.54	19.84	17.25
		1880	19.50	19.90	20.21	17.61
		1855	19.41	19.56	19.86	17.27
	1RB Middle (24)	1905	19.38	19.46	19.76	17.17
		1880	19.48	19.91	20.22	17.62
		1855	19.46	19.56	19.86	17.27
	1RB Low (0)	1905	19.44	19.48	19.78	17.19
		1880	19.47	19.94	20.25	17.65
		1855	19.37	19.55	19.85	17.26
	25RB High (25)	1905	19.58	19.63	19.94	17.34
		1880	19.59	19.63	19.94	17.34
		1855	19.62	19.70	20.01	17.41
	25RB Middle (12)	1905	19.57	19.63	19.94	17.34
		1880	19.61	19.67	19.98	17.38
		1855	19.64	19.70	20.01	17.41
	25RB Low (0)	1905	19.58	19.62	19.93	17.33
		1880	19.50	19.55	19.85	17.26
		1855	19.47	19.60	19.91	17.31
	50RB (0)	1905	19.57	19.61	19.92	17.32
		1880	19.56	19.67	19.98	17.38
		1855	19.59	19.64	19.95	17.35
15 MHz	1RB High (74)	1902.5	19.59	19.65	19.96	17.36
		1880	19.73	20.10	20.41	17.81
		1857.5	19.73	20.18	20.49	17.89
	1RB Middle	1902.5	19.64	19.69	20.00	17.40
		1880	19.72	20.09	20.40	17.80

	(37)	1857.5	19.77	20.19	20.50	17.90	
	1RB Low (0)	1902.5	19.76	19.77	20.08	17.48	
		1880	19.71	20.10	20.41	17.81	
		1857.5	19.71	20.06	20.37	17.77	
	36RB High (38)	1902.5	19.72	19.76	20.07	17.47	
		1880	19.83	19.85	20.16	17.56	
		1857.5	19.84	19.83	20.14	17.54	
	36RB Middle (19)	1902.5	19.81	19.87	20.18	17.58	
		1880	19.85	19.88	20.19	17.59	
		1857.5	19.86	19.84	20.15	17.55	
	36RB Low (0)	1902.5	19.79	19.78	20.09	17.49	
		1880	19.71	19.78	20.09	17.49	
		1857.5	19.72	19.72	20.03	17.43	
	75RB (0)	1902.5	19.81	19.83	20.14	17.54	
		1880	19.75	19.87	20.18	17.58	
		1857.5	19.79	19.79	20.10	17.50	
	20 MHz	1RB High (99)	1900	19.68	20.22	20.53	17.93
			1880	19.61	20.11	20.42	17.82
			1860	19.65	20.25	20.57	17.96
		1RB Middle (50)	1900	19.64	20.26	20.58	17.97
			1880	19.67	20.10	20.41	17.81
1860			19.60	20.25	20.57	17.96	
1RB Low (0)		1900	19.66	20.23	20.55	17.94	
		1880	19.65	20.13	20.44	17.84	
		1860	19.59	20.26	20.58	17.97	
50RB High (50)		1900	19.78	19.80	20.11	17.51	
		1880	19.78	19.82	20.13	17.53	
		1860	19.80	19.84	20.15	17.55	
50RB Middle (25)		1900	19.77	19.82	20.13	17.53	
		1880	19.83	19.82	20.13	17.53	
		1860	19.85	19.90	20.21	17.61	
50RB Low (0)		1900	19.73	19.79	20.10	17.50	
		1880	19.75	19.73	20.04	17.44	
		1860	19.72	19.78	20.09	17.49	
100RB (0)		1900	19.74	19.77	20.08	17.48	
		1880	19.83	19.84	20.15	17.55	
		1860	19.81	19.88	20.19	17.59	

Band 4							
Bandwidth (MHz)	RB allocation	Frequency (MHz)	QPSK	16QAM	64QAM	256QAM	
	RB offset (Start RB)		Actual output power (dBm)	Actual output power (dBm)	Actual output power (dBm)	Actual output power (dBm)	
1.4 MHz	1RB High (5)	1754.3	19.97	20.38	20.52	17.38	
		1732.5	19.99	20.08	20.22	17.08	
		1710.7	19.88	20.09	20.23	17.09	
	1RB Middle (3)	1754.3	20.02	20.43	20.57	17.43	
		1732.5	20.06	20.16	20.30	17.16	
		1710.7	19.97	20.15	20.29	17.15	
	1RB Low (0)	1754.3	19.94	20.39	20.53	17.39	
		1732.5	19.96	20.00	20.14	17.00	
		1710.7	19.98	20.12	20.26	17.12	
	3RB High (3)	1754.3	19.99	20.21	20.35	17.21	
		1732.5	19.99	20.22	20.36	17.22	
		1710.7	19.85	20.05	20.19	17.05	
	3RB Middle (1)	1754.3	20.02	20.26	20.40	17.26	
		1732.5	20.01	20.28	20.42	17.28	
		1710.7	19.93	20.14	20.28	17.14	
	3RB Low (0)	1754.3	19.95	20.22	20.36	17.22	
		1732.5	19.92	20.23	20.37	17.23	
		1710.7	19.86	20.09	20.23	17.09	
	6RB (0)	1754.3	19.91	19.79	19.92	17.09	
		1732.5	20.06	20.24	20.38	17.24	
		1710.7	19.97	20.08	20.22	17.08	
	3 MHz	1RB High (14)	1753.5	20.00	20.21	20.35	17.21
			1732.5	20.03	20.22	20.36	17.22
			1711.5	19.96	19.92	20.06	17.02
		1RB Middle (7)	1753.5	19.96	20.43	20.57	17.43
			1732.5	19.90	20.10	20.24	17.10
			1711.5	19.99	19.87	20.00	17.17
1RB Low (0)		1753.5	19.89	20.37	20.51	17.37	
		1732.5	19.93	20.10	20.24	17.10	
		1711.5	20.01	20.00	20.14	17.00	
8RB High (7)		1753.5	20.06	19.95	20.09	17.15	
		1732.5	20.13	20.19	20.33	17.19	
		1711.5	20.05	20.22	20.36	17.22	
8RB Middle (4)		1753.5	20.05	20.00	20.14	17.00	
		1732.5	20.17	20.20	20.34	17.20	
		1711.5	20.11	20.22	20.36	17.22	
8RB Low (0)		1753.5	20.02	19.99	20.13	17.09	
		1732.5	20.10	20.17	20.31	17.17	
		1711.5	20.05	20.19	20.33	17.19	
15RB (0)		1753.5	20.02	19.95	20.09	17.15	
		1732.5	20.13	20.15	20.29	17.15	

5 MHz	1RB High (24)	1711.5	20.08	20.14	20.28	17.14
		1752.5	19.99	20.33	20.47	17.33
		1732.5	20.06	20.71	20.85	17.71
		1712.5	20.01	20.29	20.43	17.29
	1RB Middle (12)	1752.5	19.96	20.25	20.39	17.25
		1732.5	19.98	20.59	20.73	17.59
		1712.5	19.97	20.13	20.27	17.13
	1RB Low (0)	1752.5	20.00	20.29	20.43	17.29
		1732.5	19.96	20.53	20.67	17.53
		1712.5	19.95	20.19	20.33	17.19
	12RB High (13)	1752.5	19.71	19.99	20.13	17.09
		1732.5	20.19	20.33	20.47	17.33
		1712.5	20.08	20.19	20.33	17.19
	12RB Middle (6)	1752.5	19.85	20.03	20.17	17.03
		1732.5	20.17	20.33	20.47	17.33
		1712.5	20.11	20.21	20.35	17.21
	12RB Low (0)	1752.5	19.85	20.06	20.20	17.06
		1732.5	20.04	20.22	20.36	17.22
		1712.5	20.07	20.19	20.33	17.19
	25RB (0)	1752.5	19.70	19.92	20.06	17.12
		1732.5	20.14	20.22	20.36	17.22
1712.5		20.11	20.07	20.21	17.07	
10 MHz	1RB High (49)	1750	20.09	20.16	20.30	17.16
		1732.5	20.00	20.05	20.19	17.05
		1715	20.04	20.44	20.58	17.44
	1RB Middle (24)	1750	20.11	20.07	20.21	17.07
		1732.5	19.98	20.04	20.18	17.04
		1715	20.03	20.46	20.60	17.46
	1RB Low (0)	1750	19.98	20.09	20.23	17.09
		1732.5	19.56	19.99	20.13	17.19
		1715	19.45	20.42	20.56	17.42
	25RB High (25)	1750	20.01	20.16	20.30	17.16
		1732.5	20.14	20.25	20.39	17.25
		1715	20.09	20.21	20.35	17.21
	25RB Middle (12)	1750	20.05	20.17	20.31	17.17
		1732.5	20.17	20.22	20.36	17.22
		1715	20.12	20.19	20.33	17.19
	25RB Low (0)	1750	20.04	20.12	20.26	17.12
		1732.5	20.05	20.07	20.21	17.07
		1715	19.99	20.08	20.22	17.08
	50RB (0)	1750	20.01	20.13	20.27	17.13
		1732.5	20.14	20.13	20.27	17.13
		1715	20.11	20.19	20.33	17.19
15 MHz	1RB High (74)	1747.5	20.30	20.60	20.74	17.60
		1732.5	20.15	20.60	20.74	17.60
		1717.5	20.09	20.08	20.22	17.08
	1RB Middle	1747.5	20.26	20.63	20.77	17.63
		1732.5	20.22	20.65	20.79	17.65

	(37)	1717.5	20.10	20.15	20.29	17.15	
	1RB Low (0)	1747.5	20.34	20.69	20.83	17.69	
		1732.5	20.28	20.70	20.84	17.70	
		1717.5	20.21	20.24	20.38	17.24	
	36RB High (38)	1747.5	20.29	20.38	20.52	17.38	
		1732.5	20.31	20.28	20.42	17.28	
		1717.5	20.29	20.27	20.41	17.27	
	36RB Middle (19)	1747.5	20.24	20.33	20.47	17.33	
		1732.5	20.35	20.33	20.47	17.33	
		1717.5	20.33	20.32	20.46	17.32	
	36RB Low (0)	1747.5	20.29	20.38	20.52	17.38	
		1732.5	20.31	20.28	20.42	17.28	
		1717.5	20.25	20.25	20.39	17.25	
	75RB (0)	1747.5	20.25	20.29	20.43	17.29	
		1732.5	20.21	20.25	20.39	17.25	
		1717.5	20.28	20.31	20.45	17.31	
	20 MHz	1RB High (99)	1745	20.25	20.64	20.78	17.64
			1732.5	20.21	20.82	20.96	17.82
			1720	20.16	20.71	20.85	17.71
		1RB Middle (50)	1745	20.10	20.58	20.72	17.58
			1732.5	20.18	20.72	20.86	17.72
1720			19.99	20.67	20.81	17.67	
1RB Low (0)		1745	20.20	20.48	20.62	17.48	
		1732.5	20.23	20.87	20.91	17.87	
		1720	20.16	20.82	20.96	17.82	
50RB High (50)		1745	20.32	20.25	20.39	17.25	
		1732.5	20.32	20.34	20.48	17.34	
		1720	20.30	20.32	20.46	17.32	
50RB Middle (25)		1745	20.29	20.23	20.37	17.23	
		1732.5	20.36	20.39	20.53	17.39	
		1720	20.31	20.38	20.52	17.38	
50RB Low (0)		1745	20.31	20.23	20.37	17.23	
		1732.5	20.33	20.34	20.48	17.34	
		1720	20.30	20.22	20.36	17.22	
100RB (0)		1745	20.24	20.20	20.34	17.20	
		1732.5	20.30	20.28	20.42	17.28	
		1720	20.29	20.35	20.49	17.35	

Band 7							
Bandwidth (MHz)	RB allocation	Frequency (MHz)	QPSK	16QAM	64QAM	256QAM	
	RB offset (Start RB)		Actual output power (dBm)	Actual output power (dBm)	Actual output power (dBm)	Actual output power (dBm)	
5 MHz	1RB High (24)	2567.5	19.61	19.79	19.40	17.31	
		2535	19.52	19.72	19.33	17.24	
		2502.5	19.57	20.17	19.78	17.69	
	1RB Middle (12)	2567.5	19.53	19.68	19.30	17.20	
		2535	19.50	19.70	19.31	17.22	
		2502.5	19.57	20.12	19.73	17.64	
	1RB Low (0)	2567.5	19.53	19.72	19.33	17.24	
		2535	19.52	19.71	19.32	17.23	
		2502.5	19.54	20.06	19.67	17.58	
	12RB High (13)	2567.5	19.65	19.71	19.32	17.23	
		2535	19.57	19.67	19.29	17.19	
		2502.5	19.73	19.86	19.47	17.38	
	12RB Middle (6)	2567.5	19.62	19.72	19.33	17.24	
		2535	19.57	19.70	19.31	17.22	
		2502.5	19.72	19.86	19.47	17.38	
	12RB Low (0)	2567.5	19.63	19.72	19.33	17.24	
		2535	19.61	19.68	19.30	17.20	
		2502.5	19.68	19.86	19.47	17.38	
	25RB (0)	2567.5	19.60	19.62	19.24	17.14	
		2535	19.57	19.62	19.24	17.14	
		2502.5	19.73	19.79	19.40	17.31	
	10 MHz	1RB High (49)	2565	19.58	20.01	19.62	17.53
			2535	19.39	19.53	19.15	17.05
			2505	19.50	19.47	19.09	17.09
1RB Middle (24)		2565	19.46	19.90	19.51	17.42	
		2535	19.46	19.60	19.22	17.12	
		2505	19.48	19.61	19.23	17.13	
1RB Low (0)		2565	19.44	19.97	19.58	17.49	
		2535	19.39	19.62	19.24	17.14	
		2505	19.49	19.53	19.15	17.05	
25RB High (25)		2565	19.64	19.69	19.30	17.21	
		2535	19.55	19.71	19.32	17.23	
		2505	19.71	19.74	19.35	17.26	
25RB Middle (12)		2565	19.65	19.70	19.31	17.22	
		2535	19.61	19.74	19.35	17.26	
		2505	19.75	19.77	19.38	17.29	
25RB Low (0)		2565	19.59	19.67	19.29	17.19	
		2535	19.56	19.75	19.36	17.27	
		2505	19.69	19.67	19.29	17.19	
50RB (0)		2565	19.64	19.70	19.31	17.22	
		2535	19.59	19.62	19.24	17.14	
		2505	19.73	19.70	19.31	17.22	

15 MHz	1RB High (74)	2562.5	19.76	19.81	19.42	17.33	
		2535	19.82	20.23	19.83	17.75	
		2507.5	19.87	20.15	19.76	17.67	
	1RB Middle (37)	2562.5	19.72	19.76	19.37	17.28	
		2535	19.86	20.30	19.90	17.82	
		2507.5	19.87	20.33	19.93	17.85	
	1RB Low (0)	2562.5	19.81	19.76	19.37	17.28	
		2535	19.89	20.27	19.87	17.79	
		2507.5	19.90	20.42	20.02	17.94	
	36RB High (38)	2562.5	19.79	19.83	19.44	17.35	
		2535	19.82	19.90	19.51	17.42	
		2507.5	19.94	19.94	19.55	17.46	
	36RB Middle (19)	2562.5	19.84	19.87	19.48	17.39	
		2535	19.85	19.94	19.55	17.46	
		2507.5	19.98	19.94	19.55	17.46	
	36RB Low (0)	2562.5	19.79	19.85	19.46	17.37	
		2535	19.86	19.91	19.52	17.43	
		2507.5	19.90	19.88	19.49	17.40	
	75RB (0)	2562.5	19.80	19.81	19.42	17.33	
		2535	19.81	19.88	19.49	17.40	
		2507.5	19.92	19.95	19.56	17.47	
	20 MHz	1RB High (99)	2560	19.71	20.32	19.92	17.84
			2535	19.80	20.48	20.08	18.00
			2510	19.82	20.23	19.83	17.75
		1RB Middle (50)	2560	19.76	20.34	19.94	17.86
			2535	19.82	20.35	19.95	17.87
			2510	19.82	20.25	19.85	17.77
1RB Low (0)		2560	19.77	20.38	19.98	17.90	
		2535	19.89	20.45	20.05	17.97	
		2510	19.79	20.29	19.89	17.81	
50RB High (50)		2560	19.80	19.84	19.45	17.36	
		2535	19.85	19.83	19.44	17.35	
		2510	19.91	19.90	19.51	17.42	
50RB Middle (25)		2560	19.80	19.85	19.46	17.37	
		2535	19.88	19.91	19.52	17.43	
		2510	19.97	19.96	19.57	17.48	
50RB Low (0)		2560	19.80	19.81	19.42	17.33	
		2535	19.89	19.90	19.51	17.42	
		2510	19.90	19.87	19.48	17.39	
100RB (0)		2560	19.79	19.82	19.43	17.34	
		2535	19.85	19.87	19.48	17.39	
		2510	19.93	19.93	19.54	17.45	

Table 11.4-13: The conducted Power for LTE-Level C2

Band 2							
Bandwidth (MHz)	RB allocation	Frequency (MHz)	QPSK	16QAM	64QAM	256QAM	
	RB offset (Start RB)		Actual output power (dBm)	Actual output power (dBm)	Actual output power (dBm)	Actual output power (dBm)	
1.4 MHz	1RB High (5)	1909.3	16.35	16.55	16.85	16.12	
		1880	16.43	16.62	16.92	16.19	
		1850.7	16.46	16.90	17.21	16.47	
	1RB Middle (3)	1909.3	16.43	16.57	16.87	16.14	
		1880	16.48	16.67	16.97	16.24	
		1850.7	16.53	16.96	17.27	16.53	
	1RB Low (0)	1909.3	16.37	16.50	16.80	16.07	
		1880	16.45	16.58	16.88	16.15	
		1850.7	16.45	16.89	17.20	16.46	
	3RB High (3)	1909.3	16.40	16.65	16.95	16.22	
		1880	16.38	16.55	16.85	16.12	
		1850.7	16.46	16.70	17.00	16.27	
	3RB Middle (1)	1909.3	16.42	16.69	16.99	16.26	
		1880	16.44	16.52	16.82	16.09	
		1850.7	16.50	16.76	17.06	16.33	
	3RB Low (0)	1909.3	16.34	16.61	16.91	16.18	
		1880	16.38	16.47	16.77	16.04	
		1850.7	16.48	16.71	17.01	16.28	
	6RB (0)	1909.3	16.49	16.64	16.94	16.21	
		1880	16.49	16.62	16.92	16.19	
		1850.7	16.54	16.45	16.75	16.02	
	3 MHz	1RB High (14)	1908.5	16.48	16.61	16.91	16.18
			1880	16.50	16.41	16.71	16.08
			1851.5	16.58	17.01	17.32	16.58
		1RB Middle (7)	1908.5	16.43	16.57	16.87	16.14
			1880	16.40	16.33	16.63	16.10
			1851.5	16.52	16.94	17.25	16.51
1RB Low (0)		1908.5	16.47	16.60	16.90	16.17	
		1880	16.41	16.39	16.69	16.06	
		1851.5	16.54	16.98	17.29	16.55	
8RB High (7)		1908.5	16.59	16.62	16.92	16.19	
		1880	16.56	16.72	17.02	16.29	
		1851.5	16.63	16.72	17.02	16.29	
8RB Middle (4)		1908.5	16.60	16.64	16.94	16.21	
		1880	16.59	16.71	17.01	16.28	
		1851.5	16.63	16.72	17.02	16.29	
8RB Low (0)		1908.5	16.55	16.60	16.90	16.17	
		1880	16.56	16.67	16.97	16.24	
		1851.5	16.57	16.65	16.95	16.22	
15RB (0)		1908.5	16.56	16.54	16.84	16.11	
		1880	16.58	16.60	16.90	16.17	

5 MHz	1RB High (24)	1851.5	16.59	16.65	16.95	16.22
		1907.5	16.62	16.73	17.03	16.30
		1880	16.63	16.82	17.12	16.39
	1RB Middle (12)	1852.5	16.55	17.23	17.54	16.80
		1907.5	16.55	16.67	16.97	16.24
		1880	16.54	16.65	16.95	16.22
	1RB Low (0)	1852.5	16.55	17.11	17.42	16.68
		1907.5	16.48	16.64	16.94	16.21
		1880	16.51	16.64	16.94	16.21
	12RB High (13)	1852.5	16.48	17.04	17.35	16.61
		1907.5	16.61	16.62	16.92	16.19
		1880	16.59	16.68	16.98	16.25
	12RB Middle (6)	1852.5	16.60	16.75	17.05	16.32
		1907.5	16.64	16.64	16.94	16.21
		1880	16.59	16.65	16.95	16.22
	12RB Low (0)	1852.5	16.61	16.76	17.06	16.33
		1907.5	16.51	16.53	16.83	16.10
		1880	16.55	16.66	16.96	16.23
	25RB (0)	1852.5	16.50	16.65	16.95	16.22
		1907.5	16.50	16.45	16.75	16.02
		1880	16.60	16.62	16.92	16.19
10 MHz	1RB High (49)	1852.5	16.59	16.69	16.99	16.26
		1905	16.43	16.55	16.85	16.12
		1880	16.57	16.54	16.84	16.11
	1RB Middle (24)	1855	16.68	16.97	17.28	16.54
		1905	16.43	16.49	16.79	16.06
		1880	16.43	16.47	16.77	16.04
	1RB Low (0)	1855	16.52	16.99	17.30	16.56
		1905	16.40	16.56	16.86	16.13
		1880	16.50	16.34	16.64	16.11
	25RB High (25)	1855	16.56	16.97	17.28	16.54
		1905	16.60	16.65	16.95	16.22
		1880	16.61	16.64	16.94	16.21
	25RB Middle (12)	1855	16.61	16.70	17.00	16.27
		1905	16.60	16.67	16.97	16.24
		1880	16.65	16.65	16.95	16.22
	25RB Low (0)	1855	16.65	16.67	16.97	16.24
		1905	16.55	16.62	16.92	16.19
		1880	16.56	16.53	16.83	16.10
	50RB (0)	1855	16.54	16.60	16.90	16.17
		1905	16.56	16.60	16.90	16.17
		1880	16.58	16.58	16.88	16.15
15 MHz	1RB High (74)	1855	16.63	16.64	16.94	16.21
		1902.5	16.70	16.75	17.05	16.32
		1880	16.72	17.14	17.45	16.71
	1RB Middle	1857.5	16.73	17.25	17.56	16.82
1902.5		16.74	16.71	17.01	16.28	
		1880	16.73	17.11	17.42	16.68

	(37)	1857.5	16.75	17.31	17.62	16.88	
	1RB Low (0)	1902.5	16.82	16.79	17.09	16.36	
		1880	16.82	17.13	17.44	16.70	
		1857.5	16.71	17.21	17.52	16.78	
	36RB High (38)	1902.5	16.75	16.76	17.06	16.33	
		1880	16.83	16.87	17.17	16.44	
		1857.5	16.87	16.83	17.13	16.40	
	36RB Middle (19)	1902.5	16.84	16.86	17.16	16.43	
		1880	16.82	16.90	17.21	16.47	
		1857.5	16.87	16.81	17.11	16.38	
	36RB Low (0)	1902.5	16.81	16.79	17.09	16.36	
		1880	16.72	16.77	17.07	16.34	
		1857.5	16.74	16.74	17.04	16.31	
	75RB (0)	1902.5	16.84	16.82	17.12	16.39	
		1880	16.79	16.85	17.15	16.42	
		1857.5	16.79	16.83	17.13	16.40	
	20 MHz	1RB High (99)	1900	16.77	17.15	17.46	16.72
			1880	16.63	17.22	17.53	16.79
			1860	16.73	17.17	17.48	16.74
		1RB Middle (50)	1900	16.72	17.17	17.48	16.74
			1880	16.68	17.29	17.60	16.86
1860			16.71	17.16	17.47	16.73	
1RB Low (0)		1900	16.69	17.13	17.44	16.70	
		1880	16.67	17.32	17.63	16.89	
		1860	16.76	17.31	17.62	16.88	
50RB High (50)		1900	16.75	16.77	17.07	16.34	
		1880	16.84	16.86	17.16	16.43	
		1860	16.83	16.87	17.17	16.44	
50RB Middle (25)		1900	16.77	16.77	17.07	16.34	
		1880	16.82	16.88	17.19	16.45	
		1860	16.86	16.89	17.20	16.46	
50RB Low (0)		1900	16.75	16.73	17.03	16.30	
		1880	16.72	16.75	17.05	16.32	
		1860	16.75	16.78	17.08	16.35	
100RB (0)		1900	16.78	16.81	17.11	16.38	
		1880	16.88	16.85	17.15	16.42	
		1860	16.86	16.87	17.17	16.44	

Band 4							
Bandwidth (MHz)	RB allocation	Frequency (MHz)	QPSK	16QAM	64QAM	256QAM	
	RB offset (Start RB)		Actual output power (dBm)	Actual output power (dBm)	Actual output power (dBm)	Actual output power (dBm)	
1.4 MHz	1RB High (5)	1754.3	16.91	17.06	17.22	16.56	
		1732.5	17.02	17.20	17.36	16.60	
		1710.7	16.88	17.27	17.44	16.67	
	1RB Middle (3)	1754.3	16.96	17.12	17.28	16.52	
		1732.5	17.05	17.23	17.39	16.63	
		1710.7	16.96	17.34	17.51	16.74	
	1RB Low (0)	1754.3	16.90	17.03	17.19	16.53	
		1732.5	16.99	17.15	17.31	16.55	
		1710.7	16.93	17.24	17.41	16.64	
	3RB High (3)	1754.3	16.92	17.19	17.35	16.59	
		1732.5	16.94	17.06	17.22	16.52	
		1710.7	16.90	17.19	17.35	16.59	
	3RB Middle (1)	1754.3	16.92	17.24	17.41	16.64	
		1732.5	16.97	17.14	17.30	16.54	
		1710.7	17.02	17.23	17.39	16.63	
	3RB Low (0)	1754.3	16.87	17.17	17.33	16.57	
		1732.5	16.91	17.02	17.18	16.52	
		1710.7	16.97	17.20	17.36	16.60	
	6RB (0)	1754.3	16.98	17.21	17.37	16.61	
		1732.5	17.01	17.15	17.31	16.55	
		1710.7	16.99	16.96	17.12	16.53	
	3 MHz	1RB High (14)	1753.5	17.03	17.05	17.21	16.65
			1732.5	17.10	17.58	17.75	16.98
			1711.5	16.94	17.03	17.19	16.73
		1RB Middle (7)	1753.5	16.92	17.03	17.19	16.63
			1732.5	16.99	17.41	17.58	16.81
			1711.5	16.89	16.97	17.13	16.57
1RB Low (0)		1753.5	16.89	16.99	17.15	16.59	
		1732.5	16.96	17.39	17.56	16.79	
		1711.5	16.98	17.10	17.26	16.52	
8RB High (7)		1753.5	17.09	17.19	17.35	16.59	
		1732.5	17.12	17.16	17.32	16.56	
		1711.5	17.03	17.14	17.30	16.54	
8RB Middle (4)		1753.5	17.05	17.16	17.32	16.56	
		1732.5	17.12	17.25	17.42	16.65	
		1711.5	17.06	17.15	17.31	16.55	
8RB Low (0)		1753.5	17.02	17.13	17.29	16.53	
		1732.5	17.08	17.19	17.35	16.59	
		1711.5	17.02	17.13	17.29	16.53	
15RB (0)		1753.5	17.05	17.09	17.25	16.59	
		1732.5	17.12	17.15	17.31	16.55	

5 MHz	1RB High (24)	1711.5	17.05	17.05	17.21	16.64
		1752.5	17.14	17.30	17.47	16.70
		1732.5	17.15	17.57	17.74	16.97
		1712.5	17.04	17.15	17.31	16.55
	1RB Middle (12)	1752.5	17.06	17.22	17.38	16.62
		1732.5	17.08	17.47	17.64	16.87
		1712.5	16.93	16.88	17.04	16.68
	1RB Low (0)	1752.5	17.13	17.28	17.45	16.68
		1732.5	17.01	17.44	17.61	16.84
		1712.5	16.98	17.07	17.23	16.57
	12RB High (13)	1752.5	17.09	17.21	17.37	16.61
		1732.5	17.19	17.33	17.50	16.73
		1712.5	17.13	17.19	17.35	16.59
	12RB Middle (6)	1752.5	17.10	17.24	17.41	16.64
		1732.5	17.11	17.34	17.51	16.74
		1712.5	17.09	17.21	17.37	16.61
	12RB Low (0)	1752.5	17.08	17.19	17.35	16.59
		1732.5	17.00	17.22	17.38	16.62
		1712.5	17.07	17.18	17.34	16.58
	25RB (0)	1752.5	17.12	17.18	17.34	16.58
		1732.5	17.10	17.20	17.36	16.60
1712.5		17.08	17.07	17.23	16.57	
10 MHz	1RB High (49)	1750	16.78	17.10	17.26	16.53
		1732.5	17.05	17.46	17.63	16.86
		1715	17.04	17.06	17.22	16.56
	1RB Middle (24)	1750	16.89	17.00	17.16	16.60
		1732.5	17.02	17.45	17.62	16.85
		1715	16.95	17.11	17.27	16.51
	1RB Low (0)	1750	16.91	17.00	17.16	16.60
		1732.5	16.92	17.38	17.55	16.78
		1715	16.82	17.06	17.22	16.66
	25RB High (25)	1750	17.08	17.17	17.33	16.57
		1732.5	17.14	17.21	17.37	16.61
		1715	17.13	17.24	17.41	16.64
	25RB Middle (12)	1750	17.09	17.13	17.29	16.53
		1732.5	17.15	17.21	17.37	16.61
		1715	17.12	17.23	17.39	16.63
	25RB Low (0)	1750	17.07	17.10	17.26	16.50
		1732.5	17.06	17.07	17.23	16.57
		1715	17.00	17.10	17.26	16.51
	50RB (0)	1750	17.02	17.00	17.16	16.52
		1732.5	17.12	17.18	17.34	16.58
		1715	17.08	17.16	17.32	16.56
15 MHz	1RB High (74)	1747.5	17.24	17.50	17.67	16.90
		1732.5	17.03	17.17	17.33	16.57
		1717.5	17.18	17.56	17.73	16.96
	1RB Middle	1747.5	17.25	17.57	17.74	16.97
		1732.5	17.05	17.18	17.34	16.58

	(37)	1717.5	17.17	17.55	17.72	16.95	
	1RB Low (0)	1747.5	17.31	17.76	17.93	17.16	
		1732.5	17.17	17.20	17.36	16.60	
		1717.5	17.25	17.63	17.80	17.03	
	36RB High (38)	1747.5	17.27	17.31	17.48	16.71	
		1732.5	17.27	17.32	17.49	16.72	
		1717.5	17.26	17.31	17.48	16.71	
	36RB Middle (19)	1747.5	17.25	17.26	17.43	16.66	
		1732.5	17.31	17.37	17.54	16.77	
		1717.5	17.26	17.40	17.57	16.80	
	36RB Low (0)	1747.5	17.28	17.29	17.46	16.69	
		1732.5	17.27	17.28	17.45	16.68	
		1717.5	17.23	17.33	17.50	16.73	
	75RB (0)	1747.5	17.21	17.25	17.42	16.65	
		1732.5	17.22	17.30	17.47	16.70	
		1717.5	17.28	17.36	17.53	16.76	
	20 MHz	1RB High (99)	1745	17.33	17.76	17.93	17.16
			1732.5	17.27	17.88	17.96	17.28
			1720	17.14	17.88	17.85	17.28
		1RB Middle (50)	1745	17.13	17.66	17.83	17.06
			1732.5	17.19	17.83	18.00	17.23
1720			17.00	17.81	17.98	17.21	
1RB Low (0)		1745	17.24	17.67	17.84	17.07	
		1732.5	17.25	17.85	17.92	17.25	
		1720	17.11	17.81	17.98	17.21	
50RB High (50)		1745	17.35	17.32	17.49	16.72	
		1732.5	17.29	17.33	17.50	16.73	
		1720	17.25	17.32	17.49	16.72	
50RB Middle (25)		1745	17.29	17.29	17.46	16.69	
		1732.5	17.33	17.40	17.57	16.80	
		1720	17.33	17.36	17.53	16.76	
50RB Low (0)		1745	17.29	17.29	17.46	16.69	
		1732.5	17.27	17.34	17.51	16.74	
		1720	17.27	17.35	17.52	16.75	
100RB (0)		1745	17.24	17.27	17.44	16.67	
		1732.5	17.28	17.34	17.51	16.74	
		1720	17.26	17.36	17.53	16.76	

Band 7							
Bandwidth (MHz)	RB allocation	Frequency (MHz)	QPSK	16QAM	64QAM	256QAM	
	RB offset (Start RB)		Actual output power (dBm)	Actual output power (dBm)	Actual output power (dBm)	Actual output power (dBm)	
5 MHz	1RB High (24)	2567.5	19.67	19.89	20.11	17.42	
		2535	19.62	19.78	20.00	17.31	
		2502.5	19.64	20.26	20.48	17.79	
	1RB Middle (12)	2567.5	19.57	19.76	19.98	17.29	
		2535	19.55	19.76	19.98	17.29	
		2502.5	19.66	20.15	20.37	17.68	
	1RB Low (0)	2567.5	19.61	19.79	20.01	17.32	
		2535	19.58	19.76	19.98	17.29	
		2502.5	19.57	20.15	20.37	17.68	
	12RB High (13)	2567.5	19.72	19.80	20.02	17.33	
		2535	19.67	19.76	19.98	17.29	
		2502.5	19.78	19.90	20.12	17.43	
	12RB Middle (6)	2567.5	19.68	19.79	20.01	17.32	
		2535	19.65	19.75	19.97	17.28	
		2502.5	19.76	19.91	20.13	17.44	
	12RB Low (0)	2567.5	19.70	19.78	20.00	17.31	
		2535	19.65	19.72	19.94	17.25	
		2502.5	19.77	19.89	20.11	17.42	
	25RB (0)	2567.5	19.70	19.67	19.89	17.20	
		2535	19.64	19.68	19.90	17.21	
		2502.5	19.78	19.83	20.05	17.36	
	10 MHz	1RB High (49)	2565	19.65	19.56	19.77	17.09
			2535	19.56	20.05	20.27	17.58
			2505	19.61	19.76	19.98	17.29
1RB Middle (24)		2565	19.52	19.54	19.75	17.07	
		2535	19.55	19.98	20.20	17.51	
		2505	19.61	19.68	19.90	17.21	
1RB Low (0)		2565	19.46	19.56	19.77	17.09	
		2535	19.51	20.02	20.24	17.55	
		2505	19.53	19.80	20.02	17.33	
25RB High (25)		2565	19.72	19.77	19.99	17.30	
		2535	19.64	19.67	19.89	17.20	
		2505	19.79	19.93	20.15	17.46	
25RB Middle (12)		2565	19.73	19.79	20.01	17.32	
		2535	19.71	19.75	19.97	17.28	
		2505	19.82	19.94	20.16	17.47	
25RB Low (0)		2565	19.71	19.77	19.99	17.30	
		2535	19.64	19.74	19.96	17.27	
		2505	19.69	19.83	20.05	17.36	
50RB (0)		2565	19.73	19.76	19.98	17.29	
		2535	19.64	19.71	19.93	17.24	
		2505	19.74	19.87	20.09	17.40	

15 MHz	1RB High (74)	2562.5	19.93	20.50	20.72	18.03	
		2535	19.86	19.86	20.08	17.39	
		2507.5	19.92	20.35	20.57	17.88	
	1RB Middle (37)	2562.5	19.94	20.30	20.52	17.83	
		2535	19.85	19.93	20.15	17.46	
		2507.5	19.97	20.38	20.60	17.91	
	1RB Low (0)	2562.5	19.91	20.21	20.43	17.74	
		2535	19.82	19.82	20.04	17.35	
		2507.5	19.97	20.41	20.63	17.94	
	36RB High (38)	2562.5	19.91	19.87	20.09	17.40	
		2535	19.91	19.92	20.14	17.45	
		2507.5	20.01	20.06	20.28	17.59	
	36RB Middle (19)	2562.5	19.92	19.90	20.12	17.43	
		2535	19.92	19.95	20.17	17.48	
		2507.5	20.11	20.12	20.34	17.65	
	36RB Low (0)	2562.5	19.90	19.86	20.08	17.39	
		2535	19.90	19.89	20.11	17.42	
		2507.5	19.93	19.98	20.20	17.51	
	75RB (0)	2562.5	19.91	19.90	20.12	17.43	
		2535	19.90	19.89	20.11	17.42	
		2507.5	20.02	20.07	20.29	17.60	
	20 MHz	1RB High (99)	2560	19.98	20.37	20.59	17.90
			2535	19.95	20.37	20.59	17.90
			2510	20.01	20.61	20.84	18.14
		1RB Middle (50)	2560	19.90	20.48	20.70	18.01
			2535	20.01	20.36	20.58	17.89
			2510	19.97	20.58	20.81	18.11
1RB Low (0)		2560	19.92	20.49	20.71	18.02	
		2535	20.02	20.40	20.62	17.93	
		2510	20.05	20.54	20.76	18.07	
50RB High (50)		2560	19.95	19.95	20.17	17.48	
		2535	20.02	19.97	20.19	17.50	
		2510	20.05	20.05	20.27	17.58	
50RB Middle (25)		2560	19.95	19.96	20.18	17.49	
		2535	20.01	19.98	20.20	17.51	
		2510	20.10	20.13	20.35	17.66	
50RB Low (0)		2560	19.93	19.94	20.16	17.47	
		2535	19.99	20.00	20.22	17.53	
		2510	20.00	20.06	20.28	17.59	
100RB (0)		2560	19.94	19.96	20.18	17.49	
		2535	19.98	19.96	20.18	17.49	
		2510	20.09	20.09	20.31	17.62	

Band 38						
Bandwidth (MHz)	RB allocation	Frequency (MHz)	QPSK	16QAM	64QAM	256QAM
	RB offset (Start RB)		Actual output power (dBm)	Actual output power (dBm)	Actual output power (dBm)	Actual output power (dBm)
5 MHz	1RB High (24)	2617.5	21.63	21.85	21.32	17.31
		2595	21.63	21.67	21.14	17.31
		2572.5	21.62	21.44	20.92	17.30
	1RB Middle (12)	2617.5	21.60	21.79	21.26	17.28
		2595	21.60	21.58	21.05	17.28
		2572.5	21.58	21.22	20.70	17.26
	1RB Low (0)	2617.5	21.53	21.77	21.24	17.21
		2595	21.53	21.59	21.06	17.21
		2572.5	21.60	21.15	20.63	17.28
	12RB High (13)	2617.5	21.73	20.75	20.64	17.41
		2595	21.76	20.76	20.65	17.44
		2572.5	21.45	20.61	20.51	17.13
	12RB Middle (6)	2617.5	21.75	20.76	20.65	17.43
		2595	21.75	20.79	20.68	17.43
		2572.5	21.42	20.55	20.56	17.10
	12RB Low (0)	2617.5	21.63	20.73	20.62	17.31
		2595	21.66	20.67	20.57	17.34
		2572.5	21.36	20.58	20.58	17.04
	25RB (0)	2617.5	21.70	20.72	20.61	17.38
		2595	21.75	20.76	20.65	17.43
		2572.5	21.33	20.61	20.51	17.01
10 MHz	1RB High (49)	2615	21.50	21.75	21.22	17.18
		2595	21.70	21.73	21.20	17.38
		2575	21.54	21.54	21.01	17.22
	1RB Middle (24)	2615	21.63	21.66	21.13	17.31
		2595	21.62	21.67	21.14	17.30
		2575	21.54	21.55	21.02	17.22
	1RB Low (0)	2615	21.50	21.74	21.21	17.18
		2595	21.61	21.63	21.10	17.29
		2575	21.52	21.54	21.01	17.20
	25RB High (25)	2615	21.73	20.84	20.73	17.41
		2595	21.79	20.79	20.68	17.47
		2575	21.69	20.66	20.56	17.37
	25RB Middle (12)	2615	21.75	20.78	20.67	17.43
		2595	21.79	20.82	20.71	17.47
		2575	21.73	20.68	20.58	17.41
	25RB Low (0)	2615	21.69	20.69	20.59	17.37
		2595	21.70	20.73	20.62	17.38
		2575	21.71	20.62	20.52	17.39
	50RB (0)	2615	21.72	20.78	20.67	17.40
		2595	21.77	20.78	20.67	17.45
		2575	21.72	20.67	20.57	17.40

15 MHz	1RB High (74)	2612.5	21.76	21.75	21.22	17.44
		2595	21.74	21.17	20.65	17.42
		2577.5	21.81	21.90	21.37	17.49
	1RB Middle (37)	2612.5	21.71	21.82	21.29	17.39
		2595	21.85	21.88	21.35	17.53
		2577.5	21.76	21.85	21.32	17.44
	1RB Low (0)	2612.5	21.76	21.83	21.30	17.44
		2595	21.80	21.96	21.42	17.48
		2577.5	21.74	21.75	21.22	17.42
	36RB High (38)	2612.5	21.91	20.90	20.79	17.59
		2595	22.00	21.11	20.99	17.68
		2577.5	21.91	20.93	20.82	17.59
	36RB Middle (19)	2612.5	21.86	20.84	20.73	17.54
		2595	21.99	21.03	20.92	17.67
		2577.5	21.90	20.92	20.81	17.58
	36RB Low (0)	2612.5	21.86	20.86	20.75	17.54
		2595	21.87	20.83	20.72	17.55
		2577.5	21.85	20.87	20.76	17.53
75RB (0)	2612.5	21.86	20.88	20.77	17.54	
	2595	21.94	21.01	20.90	17.62	
	2577.5	21.89	20.88	20.77	17.57	
20 MHz	1RB High (99)	2610	21.95	21.72	21.19	17.63
		2595	21.89	22.00	21.46	17.57
		2580	21.81	21.83	21.30	17.49
	1RB Middle (50)	2610	21.80	21.72	21.19	17.48
		2595	21.82	21.95	21.41	17.50
		2580	21.72	21.73	21.20	17.40
	1RB Low (0)	2610	21.84	21.74	21.21	17.52
		2595	21.81	21.57	21.04	17.49
		2580	21.75	21.78	21.25	17.43
	50RB High (50)	2610	21.93	20.96	20.85	17.61
		2595	21.97	21.01	20.90	17.65
		2580	21.92	20.89	20.78	17.60
	50RB Middle (25)	2610	21.94	20.99	20.88	17.62
		2595	21.99	21.02	20.91	17.67
		2580	21.93	20.92	20.81	17.61
	50RB Low (0)	2610	21.89	20.90	20.79	17.57
		2595	21.92	20.94	20.83	17.60
		2580	21.82	20.83	20.72	17.50
100RB (0)	2610	21.96	20.96	20.85	17.64	
	2595	21.91	20.99	20.88	17.59	
	2580	21.93	20.92	20.81	17.61	

Table 11.4-14: The conducted Power for LTE- Level D1

Band 2							
Bandwidth (MHz)	RB allocation	Frequency (MHz)	QPSK	16QAM	64QAM	256QAM	
	RB offset (Start RB)		Actual output power (dBm)	Actual output power (dBm)	Actual output power (dBm)	Actual output power (dBm)	
1.4 MHz	1RB High (5)	1909.3	18.59	18.69	18.60	17.76	
		1880	18.59	18.75	18.66	17.82	
		1850.7	18.57	18.87	18.78	17.94	
	1RB Middle (3)	1909.3	18.65	18.72	18.63	17.79	
		1880	18.65	18.78	18.69	17.85	
		1850.7	18.54	18.94	18.85	18.01	
	1RB Low (0)	1909.3	18.59	18.66	18.57	17.73	
		1880	18.62	18.69	18.60	17.76	
		1850.7	18.55	18.83	18.74	17.90	
	3RB High (3)	1909.3	18.54	18.86	18.77	17.93	
		1880	18.56	18.66	18.57	17.73	
		1850.7	18.55	18.70	18.61	17.77	
	3RB Middle (1)	1909.3	18.59	18.89	18.80	17.96	
		1880	18.55	18.71	18.62	17.78	
		1850.7	18.52	18.75	18.66	17.82	
	3RB Low (0)	1909.3	18.50	18.84	18.75	17.91	
		1880	18.50	18.65	18.56	17.72	
		1850.7	18.55	18.69	18.60	17.76	
	6RB (0)	1909.3	18.63	18.84	18.75	17.91	
		1880	18.62	18.71	18.62	17.78	
		1850.7	18.53	18.53	18.54	17.60	
	3 MHz	1RB High (14)	1908.5	18.68	18.79	18.70	17.86
			1880	18.66	18.58	18.59	17.65
			1851.5	18.60	18.97	18.88	18.04
		1RB Middle (7)	1908.5	18.54	18.72	18.63	17.79
			1880	18.54	18.51	18.52	17.58
			1851.5	18.52	18.90	18.81	17.97
1RB Low (0)		1908.5	18.53	18.77	18.68	17.84	
		1880	18.54	18.52	18.53	17.59	
		1851.5	18.56	18.95	18.86	18.02	
8RB High (7)		1908.5	18.70	18.81	18.72	17.88	
		1880	18.72	18.78	18.69	17.85	
		1851.5	18.65	18.68	18.59	17.75	
8RB Middle (4)		1908.5	18.70	18.84	18.75	17.91	
		1880	18.71	18.85	18.76	17.92	
		1851.5	18.63	18.72	18.63	17.79	
8RB Low (0)		1908.5	18.68	18.82	18.73	17.89	
		1880	18.69	18.77	18.68	17.84	
		1851.5	18.56	18.66	18.57	17.73	
15RB (0)		1908.5	18.74	18.73	18.64	17.80	
		1880	18.75	18.74	18.65	17.81	

5 MHz	1RB High (24)	1851.5	18.59	18.66	18.57	17.73	
		1907.5	18.76	18.94	18.85	18.01	
		1880	18.74	18.94	18.85	18.01	
	1RB Middle (12)	1852.5	18.61	19.13	19.04	18.20	
		1907.5	18.71	18.86	18.77	17.93	
		1880	18.65	18.82	18.73	17.89	
	1RB Low (0)	1852.5	18.55	19.10	19.01	18.17	
		1907.5	18.71	18.91	18.82	17.98	
		1880	18.67	18.81	18.72	17.88	
	12RB High (13)	1852.5	18.57	18.98	18.89	18.05	
		1907.5	18.74	18.88	18.79	17.95	
		1880	18.76	18.81	18.72	17.88	
	12RB Middle (6)	1852.5	18.66	18.77	18.68	17.84	
		1907.5	18.74	18.89	18.80	17.96	
		1880	18.78	18.90	18.81	17.97	
	12RB Low (0)	1852.5	18.67	18.78	18.69	17.85	
		1907.5	18.71	18.80	18.71	17.87	
		1880	18.69	18.74	18.65	17.81	
	25RB (0)	1852.5	18.58	18.65	18.56	17.72	
		1907.5	18.71	18.69	18.60	17.76	
		1880	18.75	18.74	18.65	17.81	
	10 MHz	1RB High (49)	1852.5	18.61	18.68	18.59	17.75
			1905	18.74	18.79	18.70	17.86
			1880	18.58	18.63	18.54	17.70
1RB Middle (24)		1855	18.60	19.11	19.02	18.18	
		1905	18.56	18.79	18.70	17.86	
		1880	18.53	18.60	18.51	17.67	
1RB Low (0)		1855	18.56	18.93	18.84	18.00	
		1905	18.72	18.79	18.70	17.86	
		1880	18.64	18.62	18.53	17.69	
25RB High (25)		1855	18.57	19.03	18.94	18.10	
		1905	18.77	18.95	18.86	18.02	
		1880	18.79	18.81	18.72	17.88	
25RB Middle (12)		1855	18.70	18.75	18.66	17.82	
		1905	18.79	18.92	18.83	17.99	
		1880	18.82	18.77	18.68	17.84	
25RB Low (0)		1855	18.69	18.69	18.60	17.76	
		1905	18.72	18.90	18.81	17.97	
		1880	18.70	18.67	18.58	17.74	
50RB (0)		1855	18.53	18.56	18.54	17.70	
		1905	18.81	18.88	18.79	17.95	
		1880	18.76	18.73	18.64	17.80	
15 MHz		1RB High (74)	1855	18.69	18.73	18.64	17.80
			1902.5	19.03	19.28	19.19	18.35
			1880	18.79	18.83	18.74	17.90
	1RB Middle	1857.5	18.85	19.28	19.19	18.35	
		1902.5	19.03	19.48	19.39	18.55	
		1880	18.85	18.84	18.75	17.91	

	(37)	1857.5	18.85	19.22	19.13	18.29	
	1RB Low (0)	1902.5	19.01	19.52	19.43	18.59	
		1880	18.89	18.93	18.84	18.00	
		1857.5	18.81	19.12	19.03	18.19	
	36RB High (38)	1902.5	18.98	18.98	18.89	18.05	
		1880	19.04	19.00	18.91	18.07	
		1857.5	18.97	18.99	18.90	18.06	
	36RB Middle (19)	1902.5	19.09	19.06	18.97	18.13	
		1880	19.03	19.01	18.92	18.08	
		1857.5	18.92	18.97	18.88	18.04	
	36RB Low (0)	1902.5	19.03	19.02	18.93	18.09	
		1880	18.88	18.86	18.77	17.93	
		1857.5	18.79	18.84	18.75	17.91	
	75RB (0)	1902.5	19.06	19.07	18.98	18.14	
		1880	19.02	19.01	18.92	18.08	
		1857.5	18.94	18.91	18.82	17.98	
	20 MHz	1RB High (99)	1900	19.20	19.61	19.52	18.68
			1880	19.14	19.61	19.52	18.68
			1860	19.01	19.50	19.41	18.57
		1RB Middle (50)	1900	19.17	19.61	19.52	18.68
			1880	19.14	19.62	19.53	18.69
1860			19.03	19.50	19.41	18.57	
1RB Low (0)		1900	19.15	19.54	19.45	18.61	
		1880	19.02	19.56	19.47	18.63	
		1860	18.95	19.54	19.45	18.61	
50RB High (50)		1900	19.25	19.18	19.09	18.25	
		1880	19.20	19.24	19.15	18.31	
		1860	19.18	19.13	19.04	18.20	
50RB Middle (25)		1900	19.26	19.19	19.10	18.26	
		1880	19.26	19.30	19.21	18.37	
		1860	19.34	19.10	19.01	18.17	
50RB Low (0)		1900	19.21	19.16	19.07	18.23	
		1880	19.13	19.12	19.03	18.19	
		1860	19.03	18.98	18.89	18.05	
100RB (0)		1900	19.23	19.21	19.12	18.28	
		1880	19.22	19.25	19.16	18.32	
		1860	19.09	19.08	18.99	18.15	

Band 4							
Bandwidth (MHz)	RB allocation	Frequency (MHz)	QPSK	16QAM	64QAM	256QAM	
	RB offset (Start RB)		Actual output power (dBm)	Actual output power (dBm)	Actual output power (dBm)	Actual output power (dBm)	
1.4 MHz	1RB High (5)	1754.3	18.80	18.91	18.96	18.18	
		1732.5	18.95	19.08	19.13	18.35	
		1710.7	18.78	18.75	18.80	18.02	
	1RB Middle (3)	1754.3	18.84	18.96	19.01	18.23	
		1732.5	19.00	19.12	19.17	18.39	
		1710.7	18.84	18.82	18.87	18.09	
	1RB Low (0)	1754.3	18.80	18.89	18.94	18.16	
		1732.5	18.94	19.03	19.08	18.30	
		1710.7	18.83	18.76	18.81	18.03	
	3RB High (3)	1754.3	18.83	19.06	19.11	18.33	
		1732.5	18.89	18.98	19.03	18.25	
		1710.7	18.78	18.68	18.73	17.95	
	3RB Middle (1)	1754.3	18.85	19.14	19.19	18.41	
		1732.5	18.91	19.05	19.10	18.32	
		1710.7	18.88	18.70	18.75	17.97	
	3RB Low (0)	1754.3	18.80	19.05	19.10	18.32	
		1732.5	18.82	18.93	18.98	18.20	
		1710.7	18.84	18.70	18.75	17.97	
	6RB (0)	1754.3	18.88	19.06	19.11	18.33	
		1732.5	18.92	19.06	19.11	18.33	
		1710.7	18.57	18.56	18.61	17.83	
	3 MHz	1RB High (14)	1753.5	18.88	18.99	19.04	18.26
			1732.5	18.95	18.94	18.99	18.21
			1711.5	18.84	19.29	19.34	18.56
		1RB Middle (7)	1753.5	18.80	18.95	19.00	18.22
			1732.5	18.87	18.86	18.91	18.13
			1711.5	18.91	19.21	19.26	18.48
1RB Low (0)		1753.5	18.81	18.95	19.00	18.22	
		1732.5	18.80	18.86	18.91	18.13	
		1711.5	18.89	19.23	19.28	18.50	
8RB High (7)		1753.5	18.97	19.03	19.08	18.30	
		1732.5	19.00	19.11	19.16	18.38	
		1711.5	18.83	18.54	18.59	17.81	
8RB Middle (4)		1753.5	18.92	19.01	19.06	18.28	
		1732.5	19.00	19.15	19.20	18.42	
		1711.5	18.79	18.51	18.56	17.78	
8RB Low (0)		1753.5	18.94	18.92	18.97	18.19	
		1732.5	18.97	19.09	19.14	18.36	
		1711.5	18.73	18.51	18.56	17.78	
15RB (0)		1753.5	18.91	18.90	18.95	18.17	
		1732.5	19.04	19.06	19.11	18.33	

5 MHz	1RB High (24)	1711.5	18.75	18.55	18.60	17.82
		1752.5	19.05	19.15	19.20	18.42
		1732.5	19.06	19.23	19.28	18.50
	1RB Middle (12)	1712.5	18.94	19.51	19.56	18.78
		1752.5	18.99	19.12	19.17	18.39
		1732.5	18.99	19.15	19.20	18.42
	1RB Low (0)	1712.5	18.89	19.35	19.40	18.62
		1752.5	18.96	19.15	19.20	18.42
		1732.5	18.98	19.12	19.17	18.39
	12RB High (13)	1712.5	18.85	19.38	19.43	18.65
		1752.5	19.01	19.08	19.13	18.35
		1732.5	19.05	19.14	19.19	18.41
	12RB Middle (6)	1712.5	19.01	19.16	19.21	18.43
		1752.5	19.05	19.04	19.09	18.31
		1732.5	19.03	19.10	19.15	18.37
	12RB Low (0)	1712.5	19.00	19.12	19.17	18.39
		1752.5	18.94	19.05	19.10	18.32
		1732.5	18.93	19.01	19.06	18.28
	25RB (0)	1712.5	18.96	19.08	19.13	18.35
		1752.5	19.03	18.95	19.00	18.22
		1732.5	19.02	19.04	19.09	18.31
10 MHz	1RB High (49)	1712.5	18.93	19.03	19.08	18.30
		1750	18.82	18.97	19.02	18.24
		1732.5	18.74	18.89	18.94	18.16
	1RB Middle (24)	1715	18.93	19.37	19.42	18.64
		1750	18.85	18.80	18.85	18.07
		1732.5	18.79	18.88	18.93	18.15
	1RB Low (0)	1715	18.87	19.29	19.34	18.56
		1750	18.77	18.93	18.98	18.20
		1732.5	18.81	18.82	18.87	18.09
	25RB High (25)	1715	18.77	19.26	19.31	18.53
		1750	18.96	18.99	19.04	18.26
		1732.5	19.06	19.06	19.11	18.33
	25RB Middle (12)	1715	19.01	19.04	19.09	18.31
		1750	18.97	19.02	19.07	18.29
		1732.5	19.05	19.05	19.10	18.32
	25RB Low (0)	1715	19.00	19.03	19.08	18.30
		1750	18.90	19.00	19.05	18.27
		1732.5	18.96	18.93	18.98	18.20
	50RB (0)	1715	18.89	18.91	18.96	18.18
		1750	18.89	18.96	19.01	18.23
		1732.5	19.01	19.02	19.07	18.29
15 MHz	1RB High (74)	1715	18.98	19.02	19.07	18.29
		1747.5	19.02	19.39	19.44	18.66
		1732.5	18.99	19.03	19.08	18.30
	1RB Middle	1717.5	19.13	19.48	19.53	18.75
		1747.5	19.09	19.49	19.54	18.76
		1732.5	19.05	19.04	19.09	18.31

	(37)	1717.5	19.07	19.49	19.54	18.76	
	1RB Low (0)	1747.5	19.24	19.59	19.64	18.86	
		1732.5	19.19	19.23	19.28	18.50	
		1717.5	19.20	19.59	19.64	18.86	
	36RB High (38)	1747.5	19.22	19.18	19.23	18.45	
		1732.5	19.19	19.18	19.23	18.45	
		1717.5	19.21	19.25	19.30	18.52	
	36RB Middle (19)	1747.5	19.23	19.16	19.21	18.43	
		1732.5	19.25	19.24	19.29	18.51	
		1717.5	19.25	19.30	19.35	18.57	
	36RB Low (0)	1747.5	19.18	19.17	19.22	18.44	
		1732.5	19.19	19.18	19.23	18.45	
		1717.5	19.16	19.20	19.25	18.47	
	75RB (0)	1747.5	19.17	19.14	19.19	18.41	
		1732.5	19.16	19.16	19.21	18.43	
		1717.5	19.14	19.28	19.33	18.55	
	20 MHz	1RB High (99)	1745	19.17	19.55	19.60	18.82
			1732.5	19.15	19.73	19.78	18.90
			1720	19.10	19.62	19.67	18.89
		1RB Middle (50)	1745	19.00	19.46	19.51	18.73
			1732.5	19.09	19.61	19.66	18.88
1720			19.00	19.57	19.62	18.84	
1RB Low (0)		1745	19.12	19.62	19.67	18.89	
		1732.5	19.14	19.74	19.79	18.91	
		1720	19.11	19.66	19.71	18.93	
50RB High (50)		1745	19.26	19.21	19.26	18.48	
		1732.5	19.22	19.24	19.29	18.51	
		1720	19.20	19.23	19.28	18.50	
50RB Middle (25)		1745	19.18	19.16	19.21	18.43	
		1732.5	19.18	19.30	19.35	18.57	
		1720	19.22	19.26	19.31	18.53	
50RB Low (0)		1745	19.21	19.20	19.25	18.47	
		1732.5	19.23	19.30	19.35	18.57	
		1720	19.17	19.25	19.30	18.52	
100RB (0)		1745	19.13	19.17	19.22	18.44	
		1732.5	19.17	19.21	19.26	18.48	
		1720	19.22	19.28	19.33	18.55	

Band 5							
Bandwidth (MHz)	RB allocation	Frequency (MHz)	QPSK	16QAM	64QAM	256QAM	
	RB offset (Start RB)		Actual output power (dBm)	Actual output power (dBm)	Actual output power (dBm)	Actual output power (dBm)	
1.4 MHz	1RB High (5)	848.3	18.00	18.13	18.61	17.62	
		836.5	18.10	18.26	18.51	17.52	
		824.7	18.02	18.35	18.40	17.41	
	1RB Middle (3)	848.3	18.12	18.22	18.84	17.85	
		836.5	18.15	18.32	18.32	17.33	
		824.7	18.10	18.47	18.47	17.48	
	1RB Low (0)	848.3	18.00	18.10	18.86	17.87	
		836.5	18.03	18.20	18.40	17.41	
		824.7	18.01	18.41	18.41	17.42	
	3RB High (3)	848.3	18.07	18.38	18.70	17.71	
		836.5	18.05	18.20	18.50	17.51	
		824.7	18.03	18.36	18.51	17.52	
	3RB Middle (1)	848.3	18.09	18.35	18.59	17.60	
		836.5	18.08	18.20	18.60	17.61	
		824.7	18.11	18.42	18.57	17.58	
	3RB Low (0)	848.3	18.03	18.33	18.55	17.56	
		836.5	18.03	18.16	18.50	17.51	
		824.7	18.08	18.34	18.55	17.56	
	6RB (0)	848.3	18.08	18.28	18.45	17.46	
		836.5	18.12	18.29	18.36	17.37	
		824.7	18.12	18.04	18.36	17.37	
	3 MHz	1RB High (14)	847.5	18.08	18.20	18.94	17.95
			836.5	18.05	18.01	18.46	17.47
			825.5	18.11	18.61	18.44	17.45
1RB Middle (7)		847.5	18.07	18.17	18.92	17.93	
		836.5	18.03	18.04	18.52	17.53	
		825.5	18.13	18.55	18.48	17.49	
1RB Low (0)		847.5	18.10	18.25	18.65	17.66	
		836.5	18.03	18.10	18.55	17.56	
		825.5	18.15	18.59	18.47	17.48	
8RB High (7)		847.5	18.17	18.25	18.55	17.56	
		836.5	18.14	18.28	18.30	17.31	
		825.5	18.18	18.25	18.58	17.59	
8RB Middle (4)		847.5	18.19	18.30	18.64	17.65	
		836.5	18.21	18.36	18.34	17.35	
		825.5	18.20	18.32	18.58	17.59	
8RB Low (0)		847.5	18.16	18.27	18.54	17.55	
		836.5	18.13	18.27	18.49	17.50	
		825.5	18.16	18.30	18.52	17.53	
15RB (0)		847.5	18.14	18.17	18.44	17.45	
		836.5	18.24	18.26	18.48	17.49	

5 MHz	1RB High (24)	825.5	18.19	18.30	18.35	17.36
		846.5	18.18	18.34	18.67	17.68
		836.5	18.24	18.57	18.61	17.62
		826.5	18.11	18.20	18.45	17.46
	1RB Middle (12)	846.5	18.11	18.31	18.66	17.67
		836.5	18.15	18.71	18.70	17.71
		826.5	18.10	18.30	18.64	17.65
	1RB Low (0)	846.5	18.23	18.37	18.80	17.81
		836.5	18.17	18.78	18.88	17.89
		826.5	18.18	18.34	18.64	17.65
	12RB High (13)	846.5	18.18	18.25	18.54	17.55
		836.5	18.20	18.39	18.53	17.54
		826.5	18.21	18.26	18.55	17.56
	12RB Middle (6)	846.5	18.21	18.34	18.53	17.54
		836.5	18.19	18.33	18.52	17.53
		826.5	18.28	18.29	18.65	17.66
	12RB Low (0)	846.5	18.27	18.35	18.62	17.63
		836.5	18.18	18.35	18.55	17.56
		826.5	18.22	18.23	18.50	17.51
	25RB (0)	846.5	18.22	18.25	18.40	17.41
		836.5	18.14	18.26	18.49	17.50
826.5		18.17	18.24	18.55	17.56	
10 MHz	1RB High (49)	844.0	18.05	18.13	18.72	17.73
		836.5	18.02	18.23	18.58	17.59
		829.0	18.11	18.47	18.54	17.55
	1RB Middle (24)	844.0	18.04	18.17	19.26	18.27
		836.5	18.02	18.10	18.62	17.63
		829.0	18.04	18.48	18.45	17.46
	1RB Low (0)	844.0	18.05	18.26	18.66	17.67
		836.5	18.00	18.16	18.51	17.52
		829.0	18.01	18.50	18.65	17.66
	25RB High (25)	844.0	18.19	18.33	18.63	17.64
		836.5	18.20	18.29	18.58	17.59
		829.0	18.17	18.33	18.55	17.56
	25RB Middle (12)	844.0	18.13	18.30	18.61	17.62
		836.5	18.19	18.22	18.53	17.54
		829.0	18.22	18.29	18.56	17.57
	25RB Low (0)	844.0	18.14	18.25	18.45	17.46
		836.5	18.17	18.23	18.48	17.49
		829.0	18.10	18.21	18.56	17.57
	50RB (0)	844.0	18.13	18.21	18.50	17.51
		836.5	18.14	18.14	18.43	17.44
		829.0	18.25	18.28	18.62	17.63

Band 7							
Bandwidth (MHz)	RB allocation	Frequency (MHz)	QPSK	16QAM	64QAM	256QAM	
	RB offset (Start RB)		Actual output power (dBm)	Actual output power (dBm)	Actual output power (dBm)	Actual output power (dBm)	
5 MHz	1RB High (24)	2567.5	17.56	17.72	18.17	16.18	
		2535	17.57	17.69	17.68	16.15	
		2502.5	17.65	18.09	17.96	16.55	
	1RB Middle (12)	2567.5	17.60	17.51	17.85	15.97	
		2535	17.60	17.65	17.89	16.11	
		2502.5	17.63	18.08	17.92	16.54	
	1RB Low (0)	2567.5	17.58	17.62	18.00	16.08	
		2535	17.59	17.79	17.76	16.25	
		2502.5	17.60	18.07	17.85	16.53	
	12RB High (13)	2567.5	17.66	17.70	17.68	16.16	
		2535	17.63	17.73	17.66	16.19	
		2502.5	17.78	17.87	17.96	16.33	
	12RB Middle (6)	2567.5	17.60	17.69	17.67	16.15	
		2535	17.63	17.67	17.64	16.13	
		2502.5	17.74	17.85	17.91	16.31	
	12RB Low (0)	2567.5	17.63	17.65	17.70	16.11	
		2535	17.64	17.69	17.69	16.15	
		2502.5	17.76	17.85	17.91	16.31	
	25RB (0)	2567.5	17.62	17.60	17.71	16.06	
		2535	17.66	17.66	17.67	16.12	
		2502.5	17.76	17.76	17.90	16.22	
	10 MHz	1RB High (49)	2565	17.54	17.56	17.40	16.02
			2535	17.51	17.56	17.82	16.02
			2505	17.67	18.03	18.07	16.49
1RB Middle (24)		2565	17.58	17.54	17.74	16.00	
		2535	17.55	17.52	17.83	15.98	
		2505	17.62	17.90	17.88	16.36	
1RB Low (0)		2565	17.58	17.55	17.73	16.01	
		2535	17.50	17.70	17.85	16.16	
		2505	17.55	17.95	17.95	16.41	
25RB High (25)		2565	17.64	17.74	17.77	16.20	
		2535	17.67	17.65	17.64	16.11	
		2505	17.76	17.78	17.79	16.24	
25RB Middle (12)		2565	17.67	17.78	17.73	16.24	
		2535	17.69	17.67	17.70	16.13	
		2505	17.76	17.78	17.88	16.24	
25RB Low (0)		2565	17.64	17.73	17.75	16.19	
		2535	17.66	17.68	17.56	16.14	
		2505	17.68	17.68	17.83	16.14	
50RB (0)		2565	17.63	17.71	17.68	16.17	
		2535	17.65	17.60	17.73	16.06	
		2505	17.72	17.77	17.85	16.23	

15 MHz	1RB High (74)	2562.5	17.71	18.30	17.95	16.76
		2535	17.72	17.73	18.04	16.19
		2507.5	17.81	18.23	18.13	16.69
	1RB Middle (37)	2562.5	17.76	18.23	18.19	16.69
		2535	17.78	17.82	18.04	16.28
		2507.5	17.83	18.38	18.01	16.84
	1RB Low (0)	2562.5	17.72	18.13	17.64	16.59
		2535	17.77	17.71	18.05	16.17
		2507.5	17.85	18.27	18.03	16.73
	36RB High (38)	2562.5	17.80	17.79	17.89	16.25
		2535	17.80	17.84	17.89	16.30
		2507.5	17.91	17.99	17.93	16.45
	36RB Middle (19)	2562.5	17.81	17.80	17.87	16.26
		2535	17.81	17.88	17.82	16.34
		2507.5	17.94	17.99	18.06	16.45
	36RB Low (0)	2562.5	17.78	17.76	17.88	16.22
		2535	17.81	17.84	17.91	16.30
		2507.5	17.86	17.93	17.92	16.39
	75RB (0)	2562.5	17.80	17.80	17.81	16.26
		2535	17.80	17.85	17.86	16.31
		2507.5	17.87	17.99	18.01	16.45
20 MHz	1RB High (99)	2560	17.74	18.35	17.64	16.81
		2535	17.79	18.39	18.03	16.85
		2510	17.78	18.26	18.06	16.72
	1RB Middle (50)	2560	17.73	18.30	18.15	16.76
		2535	17.79	18.35	17.99	16.81
		2510	17.77	18.22	18.16	16.68
	1RB Low (0)	2560	17.78	18.44	17.90	16.90
		2535	17.81	18.51	18.06	16.97
		2510	17.79	18.25	18.05	16.71
	50RB High (50)	2560	17.74	17.84	17.79	16.30
		2535	17.84	17.87	17.86	16.33
		2510	17.93	17.91	18.00	16.37
	50RB Middle (25)	2560	17.77	17.83	17.79	16.29
		2535	17.87	17.90	17.91	16.36
		2510	17.97	17.93	18.08	16.39
	50RB Low (0)	2560	17.74	17.82	17.77	16.28
		2535	17.84	17.86	17.91	16.32
		2510	17.87	17.84	18.01	16.30
	100RB (0)	2560	17.77	17.86	17.85	16.32
		2535	17.82	17.90	17.78	16.36
		2510	17.92	17.96	18.10	16.42

Band 38							
Bandwidth (MHz)	RB allocation	Frequency (MHz)	QPSK	16QAM	64QAM	256QAM	
	RB offset (Start RB)		Actual output power (dBm)	Actual output power (dBm)	Actual output power (dBm)	Actual output power (dBm)	
5 MHz	1RB High (24)	2617.5	17.53	18.01	17.63	17.93	
		2595	17.54	17.76	17.68	17.68	
		2572.5	17.51	17.84	17.62	17.76	
	1RB Middle (12)	2617.5	17.59	17.90	17.61	17.82	
		2595	17.58	17.70	17.63	17.62	
		2572.5	17.50	17.82	17.56	17.74	
	1RB Low (0)	2617.5	17.52	17.88	17.52	17.80	
		2595	17.55	17.69	17.61	17.61	
		2572.5	17.50	17.82	17.62	17.74	
	12RB High (13)	2617.5	17.63	17.68	17.72	17.60	
		2595	17.60	17.66	17.77	17.58	
		2572.5	17.59	17.57	17.73	17.49	
	12RB Middle (6)	2617.5	17.61	17.71	17.73	17.63	
		2595	17.61	17.68	17.77	17.60	
		2572.5	17.61	17.57	17.74	17.49	
	12RB Low (0)	2617.5	17.52	17.59	17.68	17.51	
		2595	17.55	17.56	17.74	17.48	
		2572.5	17.61	17.58	17.73	17.50	
	25RB (0)	2617.5	17.58	17.59	17.67	17.51	
		2595	17.60	17.61	17.79	17.53	
		2572.5	17.59	17.58	17.72	17.50	
	10 MHz	1RB High (49)	2615	17.56	17.83	17.66	17.75
			2595	17.50	17.88	17.89	17.80
			2575	17.57	17.93	17.83	17.85
1RB Middle (24)		2615	17.57	17.80	17.66	17.72	
		2595	17.52	17.85	17.86	17.77	
		2575	17.56	17.50	17.84	17.42	
1RB Low (0)		2615	17.52	17.71	17.67	17.63	
		2595	17.59	17.99	17.93	17.91	
		2575	17.53	17.87	17.97	17.79	
25RB High (25)		2615	17.55	17.55	17.55	17.47	
		2595	17.59	17.61	17.62	17.53	
		2575	17.57	17.61	17.62	17.53	
25RB Middle (12)		2615	17.59	17.61	17.63	17.53	
		2595	17.63	17.61	17.70	17.53	
		2575	17.59	17.61	17.66	17.53	
25RB Low (0)		2615	17.57	17.57	17.66	17.49	
		2595	17.52	17.52	17.58	17.44	
		2575	17.56	17.58	17.67	17.50	
50RB (0)		2615	17.55	17.55	17.63	17.47	
		2595	17.60	17.61	17.72	17.53	
		2575	17.57	17.59	17.67	17.51	

15 MHz	1RB High (74)	2612.5	17.51	17.90	17.75	17.82
		2595	17.65	18.08	17.86	18.00
		2577.5	17.61	17.93	17.81	17.85
	1RB Middle (37)	2612.5	17.53	17.93	17.77	17.85
		2595	17.61	18.09	17.88	18.01
		2577.5	17.54	17.92	17.94	17.84
	1RB Low (0)	2612.5	17.54	17.93	17.80	17.85
		2595	17.59	18.10	18.02	18.02
		2577.5	17.54	17.96	17.97	17.88
	36RB High (38)	2612.5	17.78	17.76	17.87	17.68
		2595	17.80	17.78	17.88	17.70
		2577.5	17.73	17.80	17.87	17.72
	36RB Middle (19)	2612.5	17.69	17.72	17.75	17.64
		2595	17.78	17.80	17.90	17.72
		2577.5	17.78	17.82	17.90	17.74
	36RB Low (0)	2612.5	17.68	17.71	17.89	17.63
		2595	17.72	17.72	17.91	17.64
		2577.5	17.69	17.75	17.86	17.67
75RB (0)	2612.5	17.71	17.74	17.85	17.66	
	2595	17.78	17.85	17.98	17.77	
	2577.5	17.75	17.77	17.95	17.69	
20 MHz	1RB High (99)	2610	17.77	18.00	17.91	17.92
		2595	17.74	18.18	17.85	18.10
		2580	17.71	17.94	17.85	17.86
	1RB Middle (50)	2610	17.64	17.98	17.86	17.90
		2595	17.75	18.11	17.94	18.03
		2580	17.65	17.91	17.85	17.83
	1RB Low (0)	2610	17.71	17.95	18.03	17.87
		2595	17.71	18.09	17.97	18.01
		2580	17.73	18.07	18.06	17.99
	50RB High (50)	2610	17.76	17.79	17.83	17.71
		2595	17.80	17.86	17.89	17.78
		2580	17.75	17.75	17.85	17.67
	50RB Middle (25)	2610	17.77	17.81	17.88	17.73
		2595	17.83	17.89	17.92	17.81
		2580	17.78	17.76	17.88	17.68
	50RB Low (0)	2610	17.70	17.75	17.87	17.67
		2595	17.75	17.80	17.87	17.72
		2580	17.72	17.71	17.89	17.63
100RB (0)	2610	17.78	17.82	17.96	17.74	
	2595	17.81	17.80	18.02	17.72	
	2580	17.79	17.79	17.99	17.71	

The conducted power measurement results of uplink LTE CA Conduced Power are as below:

Level A1/A2

LTE CA Class	PCC							SCC				Power	
	PCC Band width (MHz)	CC UL RB size	CC UL RB offset	CC DL RB size	CC DL RB offset	PCC UL Channel	PCC DL Channel	SCC Band width (MHz)	CC UL RB size	CC UL RB offset	SCC DL Channel	Rel 8 LTETx Power (dBm)	10 UL LTE CA Tx Power (dBm)
38C	20	1	99	100	0	38150	38150	20	1	0	37952	22.86	22.61

Level A2

LTE CA Class	PCC							SCC				Power	
	PCC Band width (MHz)	CC UL RB size	CC UL RB offset	CC DL RB size	CC DL RB offset	PCC UL Channel	PCC DL Channel	SCC Band width (MHz)	CC UL RB size	CC UL RB offset	SCC DL Channel	Rel 8 LTETx Power (dBm)	10 UL LTE CA Tx Power (dBm)
7C	20	1	0	100	0	21350	3350	20	1	0	21152	22.92	22.59

Level A1

LTE CA Class	PCC							SCC				Power	
	PCC Band width (MHz)	CC UL RB size	CC UL RB offset	CC DL RB size	CC DL RB offset	PCC UL Channel	PCC DL Channel	SCC Band width (MHz)	CC UL RB size	CC UL RB offset	SCC DL Channel	Rel 8 LTETx Power (dBm)	10 UL LTE CA Tx Power (dBm)
7C	20	1	0	100	0	21350	3350	20	1	0	21152	21.41	21.22

Level C2

LTE CA Class	PCC							SCC				Power	
	PCC Band width (MHz)	CC UL RB size	CC UL RB offset	CC DL RB size	CC DL RB offset	PCC UL Channel	PCC DL Channel	SCC Band width (MHz)	CC UL RB size	CC UL RB offset	SCC DL Channel	Rel 8 LTETx Power (dBm)	10 UL LTE CA Tx Power (dBm)
7C	20	1	99	100	0	21350	3350	20	1	0	21152	19.89	16.89
38C	20	1	99	100	0	38150	38150	20	1	0	37952	21.95	21.73

Level D1

LTE CA Class	PCC							SCC				Power	
	PCC Band width (MHz)	CC UL RB size	CC UL RB offset	CC DL RB size	CC DL RB offset	PCC UL Channel	PCC DL Channel	SCC Band width (MHz)	CC UL RB size	CC UL RB offset	SCC DL Channel	Rel 8 LTETx Power (dBm)	10 UL LTE CA Tx Power (dBm)
7C	20	1	0	100	0	21350	3350	20	1	0	21152	17.81	17.70
38C	20	1	99	100	0	38150	38150	20	1	0	37952	17.77	17.63

The conducted power measurement results of downlink LTE CA Conduted Power are as below
(2CA)

Level A1/A2:

DL LTE CA Class	PCC								SCC			Power	
	PCC Band	PCC Bandwidth (MHz)	PCC UL RB size	PCC UL RB offset	PCC DL RB size	PCC DL RB offset	PCC UL Channel	Frequency	SCC Band	SCC Bandwidth (MHz)	SCC DL Channel	Rel 8 LTETx Power(dBm)	Rel 10 DL LTE CA Tx Power(dBm)
38C	38	20	1	99	100	0	38150	2610	38	20	37952	22.86	22.37
38A-28A	38	15	1	74	75	0	38000	2595	28	20	9460	22.93	22.58

Level A2:

DL LTE CA Class	PCC								SCC			Power	
	PCC Band	PCC Bandwidth (MHz)	PCC UL RB size	PCC UL RB offset	PCC DL RB size	PCC DL RB offset	PCC UL Channel	Frequency	SCC Band	SCC Bandwidth (MHz)	SCC DL Channel	Rel 8 LTETx Power(dBm)	Rel 10 DL LTE CA Tx Power(dBm)
7A-7A	7	15	1	74	75	0	20825	2507.5	7	20	3350	22.96	22.48

Level A1:

DL LTE CA Class	PCC								SCC			Power	
	PCC Band	PCC Bandwidth (MHz)	PCC UL RB size	PCC UL RB offset	PCC DL RB size	PCC DL RB offset	PCC UL Channel	Frequency	SCC Band	SCC Bandwidth (MHz)	SCC DL Channel	Rel 8 LTETx Power(dBm)	Rel 10 DL LTE CA Tx Power(dBm)
7A-7A	7	15	36	19	75	0	20825	2507.5	7	20	3350	20.42	20.21

Level B2:

DL LTE CA Class	PCC								SCC			Power	
	PCC Band	PCC Bandwidth (MHz)	PCC UL RB size	PCC UL RB offset	PCC DL RB size	PCC DL RB offset	PCC UL Channel	Frequency	SCC Band	SCC Bandwidth (MHz)	SCC DL Channel	Rel 8 LTETx Power(dBm)	Rel 10 DL LTE CA Tx Power(dBm)
7A-7A	7	15	36	19	75	0	20825	2507.5	7	20	3350	19.98	19.33

Level C2:

DL LTE CA Class	PCC								SCC			Power	
	PCC Band	PCC Bandwidth (MHz)	PCC UL RB size	PCC UL RB offset	PCC DL RB size	PCC DL RB offset	PCC UL Channel	Frequency	SCC Band	SCC Bandwidth (MHz)	SCC DL Channel	Rel 8 LTETx Power(dBm)	Rel 10 DL LTE CA Tx Power(dBm)
7A-7A	7	15	36	19	75	0	20825	2507.5	7	20	3350	20.11	19.89
38C	38	20	1	99	100	0	38150	2610	38	20	37952	21.95	21.47
38A-28A	38	15	36	38	75	0	38000	2595	28	20	9460	22	21.53

Level D1:

DL LTE CA Class	PCC								SCC			Power	
	PCC Band	PCC Bandwidth (MHz)	PCC UL RB size	PCC UL RB offset	PCC DL RB size	PCC DL RB offset	PCC UL Channel	Frequency	SCC Band	SCC Bandwidth (MHz)	SCC DL Channel	Rel 8 LTETx Power(dBm)	Rel 10 DL LTE CA Tx Power(dBm)
7A-7A	7	15	36	19	75	0	20825	2507.5	7	20	3350	17.99	17.53

The conducted power measurement results of downlink LTE CA Conduted Power are as below
(3CA)

Level A1/A2:

DL LTE CA Class	PCC								SCC			SCC			Power	
	PCC Band	PCC Bandwidth (MHz)	PCC UL RB size	PCC UL RB offset	PCC DL RB size	PCC DL RB offset	PCC UL Channel	Frequency	SCC Band	SCC Bandwidth (MHz)	SCC DL Channel	SCC Band	SCC Bandwidth (MHz)	SCC DL Channel	Rel 8 LTETx Power(dBm)	Rel 10 DL LTE CA Tx Power(dBm)
5A-1A-7A	5	5	1	0	25	0	20625	846.5	1	20	300	7	20	3100	22.77	20.32
5A-3A-7A	5	5	1	0	25	0	20625	846.5	3	20	1575	7	20	3100	22.77	20.46

Level A2:

DL LTE CA Class	PCC								SCC			SCC			Power	
	PCC Band	PCC Bandwidth (MHz)	PCC UL RB size	PCC UL RB offset	PCC DL RB size	PCC DL RB offset	PCC UL Channel	Frequency	SCC Band	SCC Bandwidth (MHz)	SCC DL Channel	SCC Band	SCC Bandwidth (MHz)	SCC DL Channel	Rel 8 LTETx Power(dBm)	Rel 10 DL LTE CA Tx Power(dBm)
7A-3A-8A	7	15	1	74	75	0	20825	2507.5	3	20	1575	8	10	3625	22.96	20.26
7A-1A-5A	7	15	1	74	75	0	20825	2507.5	1	20	300	5	10	2525	22.96	20.37
7A-3A-5A	7	15	1	74	75	0	20825	2507.5	3	20	1575	5	10	2525	22.96	20.18

Level A1:



DL LTE CA Class	PCC							SCC			SCC			Power		
	PCC Band	PCC Bandwidth (MHz)	PCC UL RB size	PCC UL RB offset	PCC DL RB size	PCC DL RB offset	PCC UL Channel	Frequency	SCC Band	SCC Bandwidth (MHz)	SCC DL Channel	SCC Band	SCC Bandwidth (MHz)	SCC DL Channel	Rel 8 LTE Tx Power(dBm)	Rel 10 DL LTE CA Tx Power(dBm)
7A-3A-8A	7	15	36	19	75	0	20825	2507.5	3	20	1575	8	10	3625	20.42	20.11
7A-1A-5A	7	15	36	19	75	0	20825	2507.5	1	20	300	5	10	2525	20.42	20.03
7A-3A-5A	7	15	36	19	75	0	20825	2507.5	3	20	1575	5	10	2525	20.42	20.18

Level B2:

DL LTE CA Class	PCC							SCC			SCC			Power		
	PCC Band	PCC Bandwidth (MHz)	PCC UL RB size	PCC UL RB offset	PCC DL RB size	PCC DL RB offset	PCC UL Channel	Frequency	SCC Band	SCC Bandwidth (MHz)	SCC DL Channel	SCC Band	SCC Bandwidth (MHz)	SCC DL Channel	Rel 8 LTE Tx Power(dBm)	Rel 10 DL LTE CA Tx Power(dBm)
7A-3A-8A	7	15	36	19	75	0	20825	2507.5	3	20	1575	8	10	3625	19.98	19.58
7A-1A-5A	7	15	36	19	75	0	20825	2507.5	1	20	300	5	10	2525	19.98	19.43
7A-3A-5A	7	15	36	19	75	0	20825	2507.5	3	20	1575	5	10	2525	19.98	19.62

Level C2:

DL LTE CA Class	PCC							SCC			SCC			Power		
	PCC Band	PCC Bandwidth (MHz)	PCC UL RB size	PCC UL RB offset	PCC DL RB size	PCC DL RB offset	PCC UL Channel	Frequency	SCC Band	SCC Bandwidth (MHz)	SCC DL Channel	SCC Band	SCC Bandwidth (MHz)	SCC DL Channel	Rel 8 LTE Tx Power(dBm)	Rel 10 DL LTE CA Tx Power(dBm)
7A-3A-8A	7	15	36	19	75	0	20825	2507.5	3	20	1575	8	10	3625	20.11	19.86
7A-1A-5A	7	15	36	19	75	0	20825	2507.5	1	20	300	5	10	2525	20.11	19.95
7A-3A-5A	7	15	36	19	75	0	20825	2507.5	3	20	1575	5	10	2525	20.11	19.75

Level D1:

DL LTE CA Class	PCC							SCC			SCC			Power		
	PCC Band	PCC Bandwidth (MHz)	PCC UL RB size	PCC UL RB offset	PCC DL RB size	PCC DL RB offset	PCC UL Channel	Frequency	SCC Band	SCC Bandwidth (MHz)	SCC DL Channel	SCC Band	SCC Bandwidth (MHz)	SCC DL Channel	Rel 8 LTE Tx Power(dBm)	Rel 10 DL LTE CA Tx Power(dBm)
7A-3A-8A	7	15	36	19	75	0	20825	2507.5	3	20	1575	8	10	3625	17.99	17.52
7A-1A-5A	7	15	36	19	75	0	20825	2507.5	1	20	300	5	10	2525	17.99	17.6
7A-3A-5A	7	15	36	19	75	0	20825	2507.5	3	20	1575	5	10	2525	17.99	17.39

The conducted power measurement results of downlink LTE CA Conducted Power are as below (4CA)

Level A2:

DL LTE CA Class	PCC							SCC			SCC			Power					
	PCC Band	PCC Bandwidth (MHz)	PCC UL RB size	PCC UL RB offset	PCC DL RB size	PCC DL RB offset	PCC UL Channel	Frequency	SCC Band	SCC Bandwidth (MHz)	SCC DL Channel	SCC Band	SCC Bandwidth (MHz)	SCC DL Channel	Rel 8 LTE Tx Power(dBm)	Rel 10 DL LTE CA Tx Power(dBm)			
7A-1A-3A-28A	7	15	1	74	75	0	20825	2507.5	1	20	300	3	20	1575	28	20	9460	22.96	22.61
7C-3A-28A	7	15	1	74	75	0	20825	2507.5	7	15	2975	3	20	1575	28	20	9460	22.96	22.54

Level A1:

DL LTE CA Class	PCC							SCC			SCC			Power					
	PCC Band	PCC Bandwidth (MHz)	PCC UL RB size	PCC UL RB offset	PCC DL RB size	PCC DL RB offset	PCC UL Channel	Frequency	SCC Band	SCC Bandwidth (MHz)	SCC DL Channel	SCC Band	SCC Bandwidth (MHz)	SCC DL Channel	Rel 8 LTE Tx Power(dBm)	Rel 10 DL LTE CA Tx Power(dBm)			
7A-1A-3A-28A	7	15	36	19	75	0	20825	2507.5	1	20	300	3	20	1575	28	20	9460	30.42	20.14
7C-3A-28A	7	15	36	19	75	0	20825	2507.5	7	15	2975	3	20	1575	28	20	9460	30.42	20.23

Level B2:

DL LTE CA Class	PCC							SCC			SCC			Power					
	PCC Band	PCC Bandwidth (MHz)	PCC UL RB size	PCC UL RB offset	PCC DL RB size	PCC DL RB offset	PCC UL Channel	Frequency	SCC Band	SCC Bandwidth (MHz)	SCC DL Channel	SCC Band	SCC Bandwidth (MHz)	SCC DL Channel	Rel 8 LTE Tx Power(dBm)	Rel 10 DL LTE CA Tx Power(dBm)			
7A-1A-3A-28A	7	15	36	19	75	0	20825	2507.5	1	20	300	3	20	1575	28	20	9460	19.98	19.58
7C-3A-28A	7	15	36	19	75	0	20825	2507.5	7	15	2975	3	20	1575	28	20	9460	19.98	19.67

Level C2:

DL LTE CA Class	PCC							SCC			SCC			Power					
	PCC Band	PCC Bandwidth (MHz)	PCC UL RB size	PCC UL RB offset	PCC DL RB size	PCC DL RB offset	PCC UL Channel	Frequency	SCC Band	SCC Bandwidth (MHz)	SCC DL Channel	SCC Band	SCC Bandwidth (MHz)	SCC DL Channel	Rel 8 LTE Tx Power(dBm)	Rel 10 DL LTE CA Tx Power(dBm)			
7A-1A-3A-28A	7	15	36	19	75	0	20825	2507.5	1	20	300	3	20	1575	28	20	9460	30.11	19.87
7C-3A-28A	7	15	36	19	75	0	20825	2507.5	7	15	2975	3	20	1575	28	20	9460	30.11	19.75

Level D1:

DL LTE CA Class	PCC							SCC			SCC			Power					
	PCC Band	PCC Bandwidth (MHz)	PCC UL RB size	PCC UL RB offset	PCC DL RB size	PCC DL RB offset	PCC UL Channel	Frequency	SCC Band	SCC Bandwidth (MHz)	SCC DL Channel	SCC Band	SCC Bandwidth (MHz)	SCC DL Channel	Rel 8 LTE Tx Power(dBm)	Rel 10 DL LTE CA Tx Power(dBm)			
7A-1A-3A-28A	7	15	36	19	75	0	20825	2507.5	1	20	300	3	20	1575	28	20	9460	17.99	17.72
7C-3A-28A	7	15	36	19	75	0	20825	2507.5	7	15	2975	3	20	1575	28	20	9460	17.99	17.61



The conducted power measurement results of downlink LTE CA Conduced Power are as below
(5CA)

Level A2:

DL LTE CA Class	PCC							SCC			SCC			SCC			SCC			Power		
	PCC Band	PCC Bandwidth (MHz)	PCC UL RB size	PCC UL RB offset	PCC DL RB size	PCC DL RB offset	PCC UL Channel	Frequency	SCC Band	SCC Bandwidth (MHz)	SCC DL Channel	SCC Band	SCC Bandwidth (MHz)	SCC DL Channel	SCC Band	SCC Bandwidth (MHz)	SCC DL Channel	SCC Band	SCC Bandwidth (MHz)	SCC DL Channel	Rel 8 LTE Power (dBm)	Rel 14 LTE Power (dBm)
7C-3C-20A	7	15	1	74	75	0	20825	2507.5	7	15	2975	3	20	1476	3	20	1674	20	20	6300	22.96	22.43
7C-3C-1A	7	15	1	74	75	0	20825	2507.5	7	15	2975	3	20	1476	3	20	1674	1	20	300	22.96	22.4
7C-1A-3A-20A	7	15	1	74	75	0	20825	2507.5	7	15	2975	1	20	300	3	20	1575	20	20	6300	22.96	22.36
7A-1A-3A-20A-32A	7	15	1	74	75	0	20825	2507.5	1	20	300	3	20	1575	20	20	6300	32	20	10140	22.96	22.59
7A-3C-20A-32A	7	15	1	74	75	0	20825	2507.5	3	20	1476	3	20	1674	20	20	6300	32	20	10140	22.96	22.71

Level A1:

DL LTE CA Class	PCC							SCC			SCC			SCC			SCC			Power		
	PCC Band	PCC Bandwidth (MHz)	PCC UL RB size	PCC UL RB offset	PCC DL RB size	PCC DL RB offset	PCC UL Channel	Frequency	SCC Band	SCC Bandwidth (MHz)	SCC DL Channel	SCC Band	SCC Bandwidth (MHz)	SCC DL Channel	SCC Band	SCC Bandwidth (MHz)	SCC DL Channel	SCC Band	SCC Bandwidth (MHz)	SCC DL Channel	Rel 8 LTE Power (dBm)	Rel 14 LTE Power (dBm)
7C-3C-20A	7	15	36	19	75	0	20825	2507.5	7	15	2975	3	20	1476	3	20	1674	20	20	6300	20.42	20.14
7C-3C-1A	7	15	36	19	75	0	20825	2507.5	7	15	2975	3	20	1476	3	20	1674	1	20	300	20.42	20.31
7C-1A-3A-20A	7	15	36	19	75	0	20825	2507.5	7	15	2975	1	20	300	3	20	1575	20	20	6300	20.42	20.22
7A-1A-3A-20A-32A	7	15	36	19	75	0	20825	2507.5	1	20	300	3	20	1575	20	20	6300	32	20	10140	20.42	22.16
7A-3C-20A-32A	7	15	36	19	75	0	20825	2507.5	3	20	1476	3	20	1674	20	20	6300	32	20	10140	20.42	22.08

Level B2:

DL LTE CA Class	PCC							SCC			SCC			SCC			SCC			Power		
	PCC Band	PCC Bandwidth (MHz)	PCC UL RB size	PCC UL RB offset	PCC DL RB size	PCC DL RB offset	PCC UL Channel	Frequency	SCC Band	SCC Bandwidth (MHz)	SCC DL Channel	SCC Band	SCC Bandwidth (MHz)	SCC DL Channel	SCC Band	SCC Bandwidth (MHz)	SCC DL Channel	SCC Band	SCC Bandwidth (MHz)	SCC DL Channel	Rel 8 LTE Power (dBm)	Rel 14 LTE Power (dBm)
7C-3C-20A	7	15	36	19	75	0	20825	2507.5	7	15	2975	3	20	1476	3	20	1674	20	20	6300	19.98	19.48
7C-3C-1A	7	15	36	19	75	0	20825	2507.5	7	15	2975	3	20	1476	3	20	1674	1	20	300	19.98	19.52
7C-1A-3A-20A	7	15	36	19	75	0	20825	2507.5	7	15	2975	1	20	300	3	20	1575	20	20	6300	19.98	19.71
7A-1A-3A-20A-32A	7	15	36	19	75	0	20825	2507.5	1	20	300	3	20	1575	20	20	6300	32	20	10140	19.98	19.58
7A-3C-20A-32A	7	15	36	19	75	0	20825	2507.5	3	20	1476	3	20	1674	20	20	6300	32	20	10140	19.98	19.46

Level C2:

DL LTE CA Class	PCC							SCC			SCC			SCC			SCC			Power		
	PCC Band	PCC Bandwidth (MHz)	PCC UL RB size	PCC UL RB offset	PCC DL RB size	PCC DL RB offset	PCC UL Channel	Frequency	SCC Band	SCC Bandwidth (MHz)	SCC DL Channel	SCC Band	SCC Bandwidth (MHz)	SCC DL Channel	SCC Band	SCC Bandwidth (MHz)	SCC DL Channel	SCC Band	SCC Bandwidth (MHz)	SCC DL Channel	Rel 8 LTE Power (dBm)	Rel 14 LTE Power (dBm)
7C-3C-20A	7	15	36	19	75	0	20825	2507.5	7	15	2975	3	20	1476	3	20	1674	20	20	6300	20.11	19.86
7C-3C-1A	7	15	36	19	75	0	20825	2507.5	7	15	2975	3	20	1476	3	20	1674	1	20	300	20.11	19.84
7C-1A-3A-20A	7	15	36	19	75	0	20825	2507.5	7	15	2975	1	20	300	3	20	1575	20	20	6300	20.11	19.58
7A-1A-3A-20A-32A	7	15	36	19	75	0	20825	2507.5	1	20	300	3	20	1575	20	20	6300	32	20	10140	20.11	19.93
7A-3C-20A-32A	7	15	36	19	75	0	20825	2507.5	3	20	1476	3	20	1674	20	20	6300	32	20	10140	20.11	19.74

Level D1:

DL LTE CA Class	PCC							SCC			SCC			SCC			SCC			Power		
	PCC Band	PCC Bandwidth (MHz)	PCC UL RB size	PCC UL RB offset	PCC DL RB size	PCC DL RB offset	PCC UL Channel	Frequency	SCC Band	SCC Bandwidth (MHz)	SCC DL Channel	SCC Band	SCC Bandwidth (MHz)	SCC DL Channel	SCC Band	SCC Bandwidth (MHz)	SCC DL Channel	SCC Band	SCC Bandwidth (MHz)	SCC DL Channel	Rel 8 LTE Power (dBm)	Rel 14 LTE Power (dBm)
7C-3C-20A	7	15	36	19	75	0	20825	2507.5	7	15	2975	3	20	1476	3	20	1674	20	20	6300	17.99	17.73
7C-3C-1A	7	15	36	19	75	0	20825	2507.5	7	15	2975	3	20	1476	3	20	1674	1	20	300	17.99	17.52
7C-1A-3A-20A	7	15	36	19	75	0	20825	2507.5	7	15	2975	1	20	300	3	20	1575	20	20	6300	17.99	17.38
7A-1A-3A-20A-32A	7	15	36	19	75	0	20825	2507.5	1	20	300	3	20	1575	20	20	6300	32	20	10140	17.99	17.42
7A-3C-20A-32A	7	15	36	19	75	0	20825	2507.5	3	20	1476	3	20	1674	20	20	6300	32	20	10140	17.99	17.61

11.4 Wi-Fi Measurement result

For Wifi antenna, there are four sets of tune-up power, Normal power and Low power (Receiver on / Head Simultaneous / Body Simultaneous)

Table: Summary of Receiver detection mechanism

Antenna	Normal Power	Receiver on	Head Simultaneous	Body Simultaneous
WiFi Ant MIMO	Power Level A3	Power Level B3	Power Level C3	Power Level D3

The average conducted power for Wi-Fi is as following:

WLAN 2.4GHz MIMO-Power Level A3

2.4GHz		Tune up
FCC		
802.11b(dBm)		
Channel\data rate	1Mbps	23.00
11(2462MHz)	22.13	23.00
6(2437MHz)	22.28	23.00
1(2412MHz)	22.20	23.00
802.11g(dBm)		
Channel\data rate	6Mbps	
11(2462MHz)	21.05	22.00
6(2437MHz)	21.29	22.00
1(2412MHz)	21.23	22.00
802.11n(dBm)-20MHz		
Channel\data rate	MCS0	
11(2462MHz)	19.94	21.00
6(2437MHz)	20.12	21.00
1(2412MHz)	20.13	21.00
802.11n(dBm)-40MHz		
Channel\data rate	MCS0	
9(2452MHz)	20.60	21.00
6(2437MHz)	20.34	21.00
3(2422MHz)	20.38	21.00
802.11ax-20 RU26		
Channel\ rate	MCS0	
1	17.83	18.50
6	17.63	18.50
11	17.66	18.50
802.11ax-20 RU52		
Channel\ rate	MCS0	
1	17.98	18.50
6	17.71	18.50
11	17.82	18.50
802.11ax-20 RU106		
Channel\ rate	MCS0	
1	18.14	18.50
6	17.92	18.50
11	18.01	18.50
802.11ax-20 RU242		
Channel\ rate	MCS0	
1	17.72	18.50
6	17.52	18.50
11	17.65	18.50
802.11ax-40 RU242		
Channel\ rate	MCS0	
3	19.13	19.50
6	18.78	19.50
9	18.97	19.50
802.11ax-40 RU484		
Channel\ rate	MCS0	
3	19.24	19.50
6	18.86	19.50
9	18.98	19.50



WLAN 5GHz MIMO-Power Level A3

5GHz		
802.11a(dBm)		Tune up
Channel\data rate	6Mbps	
36(5180 MHz)	18.89	19.50
40(5200 MHz)	18.91	19.50
44(5220 MHz)	18.94	19.50
48(5240 MHz)	19.05	19.50
52(5260 MHz)	19.12	20.00
56(5280 MHz)	18.90	20.00
60(5300 MHz)	18.83	20.00
64(5320 MHz)	18.80	20.00
100(5500 MHz)	18.55	19.50
104(5520 MHz)	18.52	19.50
108(5540 MHz)	18.51	19.50
112(5560 MHz)	18.48	19.50
116(5580 MHz)	18.45	19.50
120(5600 MHz)	18.42	19.50
124(5620 MHz)	18.40	19.50
128(5640 MHz)	18.41	19.50
132(5660 MHz)	18.43	19.50
136(5680 MHz)	18.45	19.50
140(5700 MHz)	18.46	19.50
144(5720 MHz)	18.42	19.50
149(5745 MHz)	20.76	21.50
153(5765 MHz)	20.79	21.50
157(5785 MHz)	20.99	21.50
161(5805 MHz)	20.93	21.50
165(5825 MHz)	20.96	21.50

WLAN 2.4GHz MIMO-Power Level B3

2.4GHz		Tune up
FCC		
802.11b(dBm)		
Channel\data rate	1Mbps	
11(2462MHz)	16.64	17.50
6(2437MHz)	16.79	17.50
1(2412MHz)	16.71	17.50
802.11g(dBm)		
Channel\data rate	6Mbps	
11(2462MHz)	15.56	16.50
6(2437MHz)	15.80	16.50
1(2412MHz)	15.74	16.50
802.11n(dBm)-20MHz		
Channel\data rate	MCS0	
11(2462MHz)	14.45	15.50
6(2437MHz)	14.63	15.50
1(2412MHz)	14.64	15.50
802.11n(dBm)-40MHz		
Channel\data rate	MCS0	
9(2452MHz)	15.11	16.00
6(2437MHz)	14.85	16.00
3(2422MHz)	14.89	16.00
802.11ax-20 RU26		
Channel rate	MCS0	
1	11.50	12.00
6	11.30	12.00
11	11.33	12.00
802.11ax-20 RU52		
Channel rate	MCS0	
1	11.65	12.00
6	11.38	12.00
11	11.49	12.00
802.11ax-20 RU106		
Channel rate	MCS0	
1	11.42	12.00
6	11.19	12.00
11	11.28	12.00
802.11ax-20 RU242		
Channel rate	MCS0	
1	11.40	12.00
6	11.19	12.00
11	11.33	12.00
802.11ax-40 RU242		
Channel rate	MCS0	
3	12.40	13.00
6	12.06	13.00
9	12.25	13.00
802.11ax-40 RU484		
Channel rate	MCS0	
3	12.51	13.00
6	12.14	13.00
9	12.25	13.00



WLAN 5GHz MIMO-Power Level B3

5GHz		
802.11a(dBm)		Tune up
Channel\data rate	6Mbps	
36(5180 MHz)	16.04	17.00
40(5200 MHz)	16.06	17.00
44(5220 MHz)	16.09	17.00
48(5240 MHz)	16.20	17.00
52(5260 MHz)	16.27	17.00
56(5280 MHz)	16.05	17.00
60(5300 MHz)	15.98	17.00
64(5320 MHz)	15.95	17.00
100(5500 MHz)	15.75	16.50
104(5520 MHz)	15.67	16.50
108(5540 MHz)	15.66	16.50
112(5560 MHz)	15.63	16.50
116(5580 MHz)	15.60	16.50
120(5600 MHz)	15.57	16.50
124(5620 MHz)	15.55	16.50
128(5640 MHz)	15.56	16.50
132(5660 MHz)	15.58	16.50
136(5680 MHz)	15.60	16.50
140(5700 MHz)	15.61	16.50
144(5720 MHz)	15.57	16.50
149(5745 MHz)	17.82	18.50
153(5765 MHz)	17.83	18.50
157(5785 MHz)	17.89	18.50
161(5805 MHz)	17.79	18.50
165(5825 MHz)	17.83	18.50

WLAN 2.4GHz MIMO-Power Level C3

2.4GHz		Tune up
FCC		
802.11b(dBm)		
Channel\data rate	1Mbps	
11(2462MHz)	13.78	14.50
6(2437MHz)	13.93	14.50
1(2412MHz)	13.85	14.50
802.11g(dBm)		
Channel\data rate	6Mbps	
11(2462MHz)	12.70	13.50
6(2437MHz)	12.94	13.50
1(2412MHz)	12.88	13.50
802.11n(dBm)-20MHz		
Channel\data rate	MCS0	
11(2462MHz)	11.59	12.50
6(2437MHz)	11.77	12.50
1(2412MHz)	11.78	12.50
802.11n(dBm)-40MHz		
Channel\data rate	MCS0	
9(2452MHz)	12.25	13.00
6(2437MHz)	11.99	13.00
3(2422MHz)	12.03	13.00
802.11ax-20 RU26		
Channel\ rate	MCS0	
1	8.56	9.00
6	8.36	9.00
11	8.39	9.00
802.11ax-20 RU52		
Channel\ rate	MCS0	
1	8.61	9.00
6	8.44	9.00
11	8.55	9.00
802.11ax-20 RU106		
Channel\ rate	MCS0	
1	8.77	9.00
6	8.65	9.00
11	8.73	9.00
802.11ax-20 RU242		
Channel\ rate	MCS0	
1	8.45	9.00
6	8.25	9.00
11	8.38	9.00
802.11ax-40 RU242		
Channel\ rate	MCS0	
3	9.42	10.00
6	9.07	10.00
9	9.26	10.00
802.11ax-40 RU484		
Channel\ rate	MCS0	
3	9.53	10.00
6	9.15	10.00
9	9.26	10.00



WLAN 5GHz MIMO-Power Level C3

5GHz		
802.11a(dBm)		Tune up
Channel	data rate	6Mbps
36(5180 MHz)	11.55	12.50
40(5200 MHz)	11.57	12.50
44(5220 MHz)	11.60	12.50
48(5240 MHz)	11.71	12.50
52(5260 MHz)	11.78	12.50
56(5280 MHz)	11.56	12.50
60(5300 MHz)	11.49	12.50
64(5320 MHz)	11.46	12.50
100(5500 MHz)	11.31	12.00
104(5520 MHz)	11.18	12.00
108(5540 MHz)	11.17	12.00
112(5560 MHz)	11.14	12.00
116(5580 MHz)	11.11	12.00
120(5600 MHz)	11.08	12.00
124(5620 MHz)	11.06	12.00
128(5640 MHz)	11.07	12.00
132(5660 MHz)	11.09	12.00
136(5680 MHz)	11.11	12.00
140(5700 MHz)	11.12	12.00
144(5720 MHz)	11.08	12.00
149(5745 MHz)	12.80	13.50
153(5765 MHz)	12.88	13.50
157(5785 MHz)	12.95	13.50
161(5805 MHz)	12.83	13.50
165(5825 MHz)	12.87	13.50

WLAN 2.4GHz MIMO-Power Level D3

2.4GHz		Tune up
FCC		
802.11b(dBm)		
Channel	data rate	1Mbps
11(2462MHz)	20.36	21.00
6(2437MHz)	20.51	21.00
1(2412MHz)	20.43	21.00
802.11g(dBm)		
Channel	data rate	6Mbps
11(2462MHz)	19.28	20.00
6(2437MHz)	19.52	20.00
1(2412MHz)	19.46	20.00
802.11n(dBm)-20MHz		
Channel	data rate	MCS0
11(2462MHz)	18.17	19.00
6(2437MHz)	18.35	19.00
1(2412MHz)	18.36	19.00
802.11n(dBm)-40MHz		
Channel	data rate	MCS0
9(2452MHz)	18.83	19.50
6(2437MHz)	18.57	19.50
3(2422MHz)	18.61	19.50
802.11ax-20 RU26		
Channel	rate	MCS0
1	15.53	16.00
6	15.33	16.00
11	15.37	16.00
802.11ax-20 RU52		
Channel	rate	MCS0
1	15.68	16.00
6	15.42	16.00
11	15.53	16.00
802.11ax-20 RU106		
Channel	rate	MCS0
1	15.75	16.00
6	15.62	16.00
11	15.71	16.00
802.11ax-20 RU242		
Channel	rate	MCS0
1	15.43	16.00
6	15.22	16.00
11	15.36	16.00
802.11ax-40 RU242		
Channel	rate	MCS0
3	16.53	17.00
6	16.19	17.00
9	16.38	17.00
802.11ax-40 RU484		
Channel	rate	MCS0
3	16.54	17.00
6	16.27	17.00
9	16.38	17.00

11.4 BT Measurement result

The average conducted power for BT is as following:

Normal Power

ANT3	0 (2402)	39 (2440)	78 (2480)	Tune up
	18.98	18.94	18.86	19.5
ANT4	0 (2402)	39 (2440)	78 (2480)	Tune up
	18.17	18.09	17.14	18.5

Low Power

ANT3	0 (2402)	39 (2440)	78 (2480)	Tune up
	10.16	11.05	10.21	11.5

12 Simultaneous TX SAR Considerations

12.1 Introduction

The following procedures adopted from “FCC SAR Considerations for Cell Phones with Multiple Transmitters” are applicable to handsets with built-in unlicensed transmitters such as 802.11 a/b/g and Bluetooth devices which may simultaneously transmit with the licensed transmitter. For this device, the BT and Wi-Fi can transmit simultaneous with other transmitters.

12.2 Transmit Antenna Separation Distances

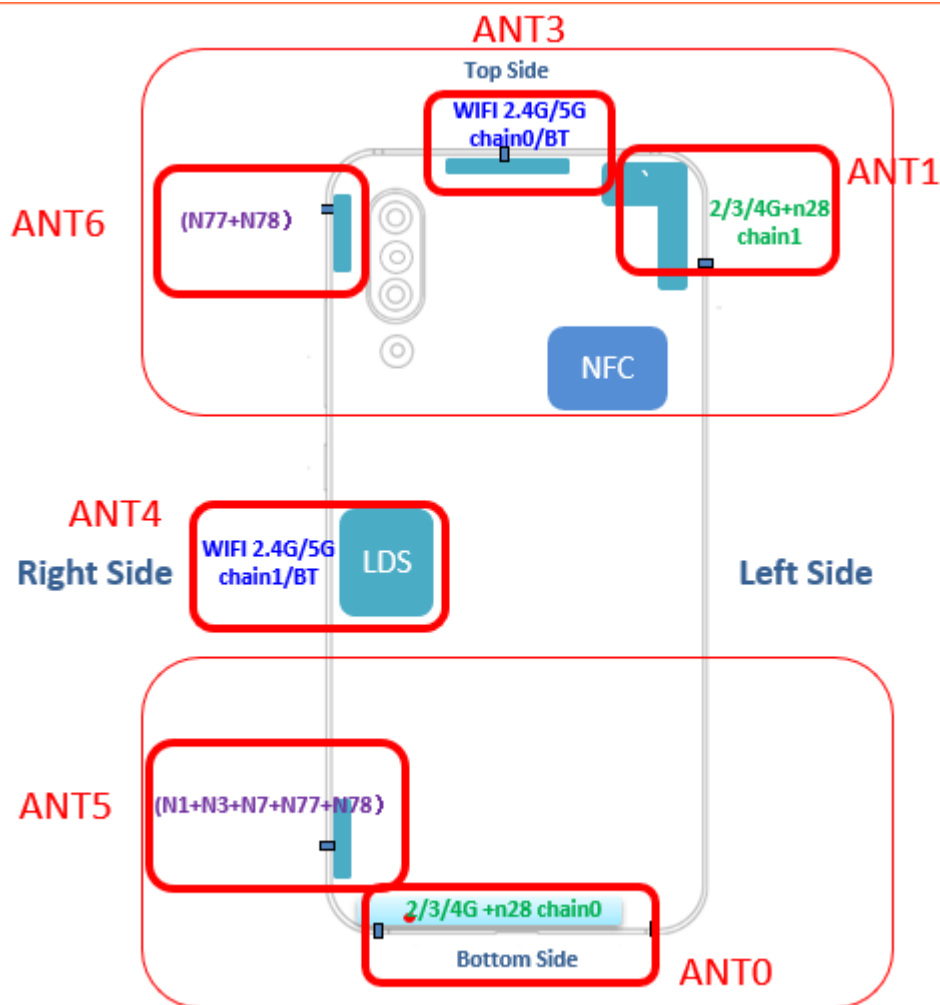

Picture 12.1 Antenna Locations

12.3 SAR Measurement Positions

According to the KDB941225 D06 Hot Spot SAR v01, the edges with less than 2.5 cm distance to the antennas need to be tested for SAR.

SAR measurement positions						
Mode	Front	Rear	Left edge	Right edge	Top edge	Bottom edge
Secondary antenna	Yes	Yes	Yes	No	Yes	No
Main antenna	Yes	Yes	Yes	Yes	No	Yes
WLAN	Yes	Yes	No	Yes	Yes	No

12.4 Standalone SAR Test Exclusion Considerations

Standalone 1-g head or body SAR evaluation by measurement or numerical simulation is not required when the corresponding SAR Exclusion Threshold condition, listed below, is satisfied. The 1-g SAR test exclusion threshold for 100 MHz to 6 GHz at test separation distances ≤ 50 mm are determined by:

$[(\text{max. power of channel, including tune-up tolerance, mW}) / (\text{min. test separation distance, mm})] \cdot [\sqrt{f(\text{GHz})}] \leq 3.0$ for 1-g SAR, where

- $f(\text{GHz})$ is the RF channel transmit frequency in GHz
- Power and distance are rounded to the nearest mW and mm before calculation
- The result is rounded to one decimal place for comparison

Table 12.1: Standalone SAR test exclusion considerations

Band/Mode	F(GHz)	Position	SAR test exclusion threshold(mW)	RF output power		SAR test exclusion
				dBm	mW	
Bluetooth	2.441	Head	9.60	19.5	89.13	No
		Body	19.20	19.5	89.13	No
2.4GHz WLAN	2.45	Head	9.58	17.5	56.23	No
		Body	19.17	23	199.53	No
5GHz WLAN	5.2	Head	6.58	17	50.12	No
		Body	13.16	19.5	89.13	No
	5.3	Head	6.52	17	50.12	No
		Body	13.03	20	100	No
	5.6	Head	6.34	16.5	44.67	No
		Body	12.68	19.5	89.13	No
	5.8	Head	6.23	18.5	70.79	No
		Body	12.46	21.5	141.25	No

13 Evaluation of Simultaneous

Main antenna

Table 13.1: The sum of reported SAR values for main antenna and WiFi2.4G+5G

	Position	Main antenna	WiFi2.4G	WiFi5G	Sum
Highest reported SAR value for Head	Right hand, Tilt	0.14	0.33	0.18	0.65
Highest reported SAR value for Body	Rear 10mm	0.49	0.12	0.35	0.96

Table 13.2: The sum of reported SAR values for main antenna and WiFi2.4G

	Position	Main antenna	WiFi2.4G	Sum
Highest reported SAR value for Head	Right hand, Tilt	0.14	0.72	0.86
Highest reported SAR value for Body	Bottom 10mm	0.93	/	0.93

Table 13.3: The sum of reported SAR values for main antenna and WiFi5G

	Position	Main antenna	WiFi5G	Sum
Highest reported SAR value for Head	Left hand, Tilt	0.15	0.31	0.46
Highest reported SAR value for Body	Bottom 10mm	0.93	/	0.93

Table 13.4: The sum of reported SAR values for main antenna and WiFi5G+BT

	Position	Main antenna	WiFi5G	BT	Sum
Highest reported SAR value for Head	Left hand, Tilt	0.15	0.31	0.13	0.59
Highest reported SAR value for Body	Bottom 10mm	0.93	/	/	0.93

Table 13.5: The sum of reported SAR values for WiFi2.4G and WiFi5G

	Position	WiFi2.4G	WiFi5G	Sum
Highest reported SAR value for Head	Right hand, Tilt	0.18	0.72	0.90
Highest reported SAR value for Body	Rear 10mm	0.35	0.33	0.68

Table 13.6: The sum of reported SAR values for WiFi5G and BT

	Position	WiFi5G	BT	Sum
Highest reported SAR value for Head	Left hand, Tilt	1.09	0.13	1.22
Highest reported SAR value for Body	Rear 10mm	0.35	0.03	0.38

Second antenna

Table 13.7: The sum of reported SAR values for main antenna and WiFi2.4G+5G

	Position	Main antenna	WiFi2.4G	WiFi5G	Sum
Highest reported SAR value for Head	Right hand, Tilt	0.82	0.33	0.18	1.33
Highest reported SAR value for Body	Rear 10mm	0.48	0.12	0.35	0.95

Table 13.8: The sum of reported SAR values for main antenna and WiFi2.4G

	Position	Main antenna	WiFi2.4G	Sum
Highest reported SAR value for Head	Right hand, Tilt	0.82	0.72	1.54
Highest reported SAR value for Body	Top 10mm	0.58	0.56	1.14

Table 13.9: The sum of reported SAR values for main antenna and WiFi5G

	Position	Main antenna	WiFi5G	Sum
Highest reported SAR value for Head	Right hand, Cheek	0.99	0.14	1.13
Highest reported SAR value for Body	Rear 10mm	0.48	0.35	0.83

Table 13.4: The sum of reported SAR values for main antenna and WiFi5G+BT

	Position	Main antenna	WiFi5G	BT	Sum
Highest reported SAR value for Head	Right hand, Cheek	0.99	0.14	0.11	1.24
Highest reported SAR value for Body	Rear 10mm	0.48	0.35	0.03	0.86

Conclusion:

According to the above tables, the sum of reported SAR values is <math>< 1.6\text{W/kg}</math>. So the simultaneous transmission SAR with volume scans is not required.

14 SAR Test Result

It is determined by user manual for the distance between the EUT and the phantom bottom. The distance is 10 mm or 15mm and just applied to the condition of body worn accessory.

It is performed for all SAR measurements with area scan based 1-g SAR estimation (Fast SAR). A zoom scan measurement is added when the estimated 1-gSAR is the highest measured SAR in each exposure configuration, wireless mode and frequency band combination or more than 1.2W/kg.

The calculated SAR is obtained by the following formula:

$$\text{Reported SAR} = \text{Measured SAR} \times 10^{(P_{\text{Target}} - P_{\text{Measured}})/10}$$

Where P_{Target} is the power of manufacturing upper limit;

P_{Measured} is the measured power in chapter 11.

Table 14.1: Duty Cycle

Mode	Duty Cycle
Speech for GSM	1:8.3
GPRS&EGPRS for GSM850- Normal Power	1:8.3
GPRS&EGPRS for 1900- Normal Power	1:4
GPRS&EGPRS for GSM1900-Low Power	1:8.3
WCDMA<E FDD	1:1
LTE TDD	1:1.58

Note:

J1: This data is variant product, carry out spot checks.

B1: This data is 8+128G, carry out spot checks.

ANT0: This data is single shot by wifi.

14.1 SAR results for Second antenna

Table 14.1-1: SAR Values (GSM 850 MHz Band - Head)

Ambient Temperature: 22.9°C						Liquid Temperature: 22.5°C					
Frequency		Side	Test Position	Figure No.	Conducted Power (dBm)	Max. tune-up Power (dBm)	Measured SAR(10g) (W/kg)	Reported SAR(10g) (W/kg)	Measured SAR(1g) (W/kg)	Reported SAR(1g) (W/kg)	Power Drift (dB)
Ch.	MHz										
190	836.6	Left	Touch	/	28.72	30.50	0.104	0.16	0.193	0.29	0.05
190	836.6	Left	Tilt	/	28.72	30.50	0.1	0.15	0.189	0.28	0.03
190	836.6	Right	Touch	/	28.72	30.50	0.239	0.36	0.468	0.71	0.00
251	848.8	Right	Tilt	Fig.1	28.87	30.50	0.259	0.38	0.566	0.82	0.07
190	836.6	Right	Tilt	/	28.72	30.50	0.257	0.39	0.521	0.78	-0.03
128	824.2	Right	Tilt	/	28.79	30.50	0.241	0.36	0.494	0.73	0.08
251	848.8	Right	Tilt	J1	28.87	30.50	0.233	0.34	0.460	0.67	-0.14
251	848.8	Right	Tilt	B1	28.87	30.50	0.214	0.31	0.431	0.63	0.02

Table 14.1-2: SAR Values (GSM 850 MHz Band - Body)

Ambient Temperature: 22.9°C						Liquid Temperature: 22.5°C					
Frequency		Mode (number of timeslots)	Test Position	Figure No.	Conducted Power (dBm)	Max. tune-up Power (dBm)	Measured SAR(10g) (W/kg)	Reported SAR(10g) (W/kg)	Measured SAR(1g) (W/kg)	Reported SAR(1g) (W/kg)	Power Drift (dB)
Ch.	MHz										
190	836.6	GPRS (1)	Front	/	32.58	33.50	0.036	0.04	0.059	0.07	-0.13
251	848.8	GPRS (1)	Rear	/	32.15	33.50	0.037	0.05	0.061	0.08	-0.05
190	836.6	GPRS (1)	Rear	/	32.58	33.50	0.038	0.05	0.063	0.08	-0.13
128	824.2	GPRS (1)	Rear	Fig.2	32.30	33.50	0.042	0.06	0.071	0.09	0.02
190	836.6	GPRS (1)	Left	/	32.58	33.50	0.032	0.04	0.06	0.07	-0.03
190	836.6	GPRS (1)	Top	/	32.58	33.50	0.034	0.04	0.057	0.07	-0.06
128	824.2	EGPRS (1)	Rear	/	32.34	30.50	0.034	0.02	0.062	0.04	0.14

Note: The distance between the EUT and the phantom bottom is 10mm.

Table 14.1-3: SAR Values (GSM 1900 MHz Band - Head)

Ambient Temperature: 22.9°C						Liquid Temperature: 22.5°C					
Frequency		Side	Test Position	Figure No.	Conducted Power (dBm)	Max. tune-up Power (dBm)	Measured SAR(10g) (W/kg)	Reported SAR(10g) (W/kg)	Measured SAR(1g) (W/kg)	Reported SAR(1g) (W/kg)	Power Drift (dB)
Ch.	MHz										
661	1880	Left	Touch	/	29.69	30.50	0.093	0.11	0.162	0.20	-0.12
661	1880	Left	Tilt	/	29.69	30.50	0.079	0.10	0.142	0.17	0.13
810	1909.8	Right	Touch	/	29.56	30.50	0.252	0.31	0.513	0.64	-0.11
661	1880	Right	Touch	/	29.69	30.50	0.249	0.30	0.495	0.60	-0.05
512	1850.2	Right	Touch	Fig.3	29.43	30.50	0.286	0.37	0.55	0.70	-0.11
661	1880	Right	Tilt	/	29.69	30.50	0.235	0.28	0.487	0.59	0.11

Table 14.1-4: SAR Values (GSM 1900 MHz Band - Body)

Frequency		Mode (number of timeslots)	Test Position	Figure No.	Conducted Power (dBm)	Max. tune-up Power (dBm)	Measured SAR(10g) (W/kg)	Reported SAR(10g) (W/kg)	Measured SAR(1g) (W/kg)	Reported SAR(1g) (W/kg)	Power Drift (dB)
Ch.	MHz										
Ambient Temperature: 22.9 °C		Liquid Temperature: 22.5 °C									
661	1880	GPRS (2)	Front	/	26.31	27.50	0.091	0.12	0.16	0.21	-0.09
661	1880	GPRS (2)	Rear	/	26.31	27.50	0.089	0.12	0.157	0.21	0.13
810	1909.8	GPRS (2)	Left	/	26.26	27.50	0.109	0.14	0.221	0.29	0.02
661	1880	GPRS (2)	Left	/	26.31	27.50	0.123	0.16	0.265	0.35	-0.06
512	1850.2	GPRS (2)	Left	Fig.4	26.26	27.50	0.147	0.20	0.294	0.39	0.13
661	1880	GPRS (2)	Top	/	26.31	27.50	0.075	0.10	0.143	0.19	-0.12
810	1909.8	EGPRS (2)	Left	/	26.43	27.50	0.131	0.17	0.274	0.35	0.08

Note1: The distance between the EUT and the phantom bottom is 10mm

Table 14.1-5: SAR Values (WCDMA 1900 MHz Band - Head)

Frequency		Side	Test Position	Figure No.	Conducted Power (dBm)	Max. tune-up Power (dBm)	Measured SAR(10g) (W/kg)	Reported SAR(10g) (W/kg)	Measured SAR(1g) (W/kg)	Reported SAR(1g) (W/kg)	Power Drift (dB)
Ch.	MHz										
Ambient Temperature: 22.9 °C		Liquid Temperature: 22.5 °C									
9800	1880	Left	Touch	/	19.01	20.50	0.123	0.17	0.2	0.28	0.07
9800	1880	Left	Tilt	/	19.01	20.50	0.084	0.12	0.141	0.20	0.01
9938	1907.6	Right	Touch	/	19.04	20.50	0.246	0.34	0.449	0.63	0.06
9800	1880	Right	Touch	/	19.01	20.50	0.256	0.36	0.469	0.66	-0.09
9662	1852.4	Right	Touch	Fig.5	18.83	20.50	0.269	0.40	0.492	0.72	0.00
9800	1880	Right	Tilt	/	19.01	20.50	0.22	0.31	0.416	0.59	-0.09

Table 14.1-6: SAR Values (WCDMA 1900 MHz Band - Body)

Frequency		Test Position	Figure No.	Conducted Power (dBm)	Max. tune-up Power (dBm)	Measured SAR(10g) (W/kg)	Reported SAR(10g) (W/kg)	Measured SAR(1g) (W/kg)	Reported SAR(1g) (W/kg)	Power Drift (dB)	
Ch.	MHz										
Ambient Temperature: 22.9 °C		Liquid Temperature: 22.5 °C									
9800	1880	Front	/	23.78	25.00	0.176	0.23	0.343	0.45	-0.01	
9800	1880	Rear	/	23.78	25.00	0.183	0.24	0.365	0.48	0.00	
9938	1907.6	Left	/	23.76	25.00	0.235	0.31	0.541	0.72	-0.01	
9800	1880	Left	Fig.6	23.78	25.00	0.269	0.36	0.593	0.79	-0.04	
9662	1852.4	Left	/	23.72	25.00	0.25	0.34	0.56	0.75	-0.07	
9800	1880	Top	/	23.78	25.00	0.203	0.27	0.435	0.58	-0.08	

Note1: The distance between the EUT and the phantom bottom is 10mm

Table 14.1-7: SAR Values (WCDMA 1700 MHz Band - Head)

Frequency		Side	Test Position	Figure No.	Conducted Power (dBm)	Max. tune-up Power (dBm)	Measured SAR(10g) (W/kg)	Reported SAR(10g) (W/kg)	Measured SAR(1g) (W/kg)	Reported SAR(1g) (W/kg)	Power Drift (dB)
Ch.	MHz										
Ambient Temperature: 22.9 °C Liquid Temperature: 22.5°C											
1412	1732.4	Left	Touch	/	19.26	21.00	0.138	0.21	0.218	0.33	-0.12
1412	1732.4	Left	Tilt	/	19.26	21.00	0.188	0.28	0.325	0.49	0.11
1513	1752.6	Right	Touch	Fig.7	19.37	21.00	0.326	0.47	0.609	0.89	-0.04
1412	1732.4	Right	Touch	/	19.26	21.00	0.3	0.45	0.558	0.83	-0.09
1312	1712.4	Right	Touch	/	19.14	21.00	0.221	0.34	0.41	0.63	-0.12
1412	1732.4	Right	Tilt	/	19.26	21.00	0.263	0.39	0.48	0.72	-0.12

Table 14.1-8: SAR Values (WCDMA 1700 MHz Band - Body)

Frequency		Test Position	Figure No.	Conducted Power (dBm)	Max. tune-up Power (dBm)	Measured SAR(10g) (W/kg)	Reported SAR(10g) (W/kg)	Measured SAR(1g) (W/kg)	Reported SAR(1g) (W/kg)	Power Drift (dB)
Ch.	MHz									
Ambient Temperature: 22.9 °C Liquid Temperature: 22.5°C										
1412	1732.5	Front	/	23.84	25.00	0.057	0.07	0.095	0.12	-0.10
1412	1732.5	Rear	/	23.84	25.00	0.075	0.10	0.123	0.16	0.07
1513	1752.6	Left	/	23.86	25.00	0.11	0.14	0.183	0.24	-0.02
1412	1732.5	Left	/	23.84	25.00	0.147	0.19	0.261	0.34	-0.03
1312	1712.4	Left	Fig.8	23.64	25.00	0.155	0.21	0.29	0.40	0.12
1412	1732.5	Top	/	23.84	25.00	0.134	0.18	0.246	0.32	-0.06

Note1: The distance between the EUT and the phantom bottom is 10mm

Table 14.1-9: SAR Values (WCDMA 850 MHz Band - Head)

Frequency		Side	Test Position	Figure No.	Conducted Power (dBm)	Max. tune-up Power (dBm)	Measured SAR(10g) (W/kg)	Reported SAR(10g) (W/kg)	Measured SAR(1g) (W/kg)	Reported SAR(1g) (W/kg)	Power Drift (dB)
Ch.	MHz										
Ambient Temperature: 22.9 °C Liquid Temperature: 22.5°C											
4182	836.4	Left	Touch	/	18.46	20.00	0.116	0.17	0.215	0.31	0.03
4182	836.4	Left	Tilt	/	18.46	20.00	0.123	0.18	0.235	0.34	-0.04
4182	836.4	Right	Touch	/	18.46	20.00	0.24	0.34	0.474	0.68	-0.01
4233	846.6	Right	Tilt	/	18.43	20.00	0.242	0.35	0.533	0.77	0.08
4182	836.4	Right	Tilt	/	18.46	20.00	0.257	0.37	0.545	0.78	0.02
4132	826.4	Right	Tilt	Fig.9	18.49	20.00	0.259	0.37	0.568	0.80	0.09

Table 14.1-10: SAR Values (WCDMA 850 MHz Band - Body)

Ambient Temperature: 22.9 °C						Liquid Temperature: 22.5 °C				
Frequency		Test Position	Figure No.	Conducted Power (dBm)	Max. tune-up Power (dBm)	Measured SAR(10g) (W/kg)	Reported SAR(10g) (W/kg)	Measured SAR(1g) (W/kg)	Reported SAR(1g) (W/kg)	Power Drift (dB)
Ch.	MHz									
4233	846.6	Front	/	23.94	25.00	0.107	0.14	0.164	0.21	0.09
4182	836.4	Front	Fig.10	23.95	25.00	0.116	0.15	0.213	0.27	-0.13
4132	826.4	Front	/	23.79	25.00	0.116	0.15	0.177	0.23	0.07
4182	836.4	Rear	/	23.95	25.00	0.094	0.12	0.136	0.17	0.04
4182	836.4	Left	/	23.95	25.00	0.08	0.10	0.135	0.17	0.04
4182	836.4	Top	/	23.95	25.00	0.089	0.11	0.189	0.24	-0.05

Note: The distance between the EUT and the phantom bottom is 10mm.

Table 14.1-11: SAR Values (LTE Band2 - Head)

Ambient Temperature: 22.9 °C						Liquid Temperature: 22.5 °C						
Frequency		Mode	Side	Test Position	Figure No.	Conducted Power (dBm)	Max. tune-up Power (dBm)	Measured SAR(10g) (W/kg)	Reported SAR(10g) (W/kg)	Measured SAR(1g) (W/kg)	Reported SAR(1g) (W/kg)	Power Drift (dB)
Ch.	MHz											
19100	1900	1RB_High	Left	Touch	/	19.20	20.50	0.083	0.11	0.141	0.19	0.09
19100	1900	1RB_High	Left	Tilt	/	19.20	20.50	0.279	0.38	0.495	0.67	-0.03
19100	1900	1RB_High	Right	Touch	Fig.11	19.20	20.50	0.284	0.38	0.554	0.75	-0.09
19100	1900	1RB_High	Right	Tilt	/	19.20	20.50	0.197	0.27	0.367	0.50	-0.02
18700	1860	50RB_Mid	Left	Touch	/	19.34	20.50	0.099	0.13	0.168	0.22	0.05
18700	1860	50RB_Mid	Left	Tilt	/	19.34	20.50	0.264	0.34	0.448	0.59	-0.04
18700	1860	50RB_Mid	Right	Touch	/	19.34	20.50	0.199	0.26	0.386	0.50	0.09
18700	1860	50RB_Mid	Right	Tilt	/	19.34	20.50	0.173	0.23	0.349	0.46	0.04

Note1: The LTE mode is QPSK_20MHz.

Table 14.1-12: SAR Values (LTE Band2 - Body)

Ambient Temperature: 22.9 °C						Liquid Temperature: 22.5 °C					
Frequency		Mode	Test Position	Figure No.	Conducted Power (dBm)	Max. tune-up Power (dBm)	Measured SAR(10g) (W/kg)	Reported SAR(10g) (W/kg)	Measured SAR(1g) (W/kg)	Reported SAR(1g) (W/kg)	Power Drift (dB)
Ch.	MHz										
19100	1900	1RB_High	Front	/	22.69	24.00	0.144	0.19	0.294	0.40	-0.05
19100	1900	1RB_High	Rear	/	22.69	24.00	0.115	0.16	0.241	0.33	0.12
19100	1900	1RB_High	Left	/	22.69	24.00	0.146	0.20	0.328	0.44	0.12
19100	1900	1RB_High	Top	/	22.69	24.00	0.076	0.10	0.174	0.24	-0.09
18700	1860	50RB_Mid	Front	/	21.83	23.00	0.089	0.12	0.175	0.23	0.05
18700	1860	50RB_Mid	Rear	/	21.83	23.00	0.101	0.13	0.199	0.26	-0.03
18700	1860	50RB_Mid	Left	Fig.12	21.83	23.00	0.189	0.25	0.407	0.53	-0.01
18700	1860	50RB_Mid	Top	/	21.83	23.00	0.089	0.12	0.198	0.26	-0.12

Note1: The distance between the EUT and the phantom bottom is 10mm

Note2: The LTE mode is QPSK_20MHz.

Table 14.1-13: SAR Values (LTE Band4 - Head)

Ambient Temperature: 22.9 °C						Liquid Temperature: 22.5 °C						
Frequency		Mode	Side	Test Position	Figure No.	Conducted Power (dBm)	Max. tune-up Power (dBm)	Measured SAR(10g) (W/kg)	Reported SAR(10g) (W/kg)	Measured SAR(1g) (W/kg)	Reported SAR(1g) (W/kg)	Power Drift (dB)
Ch.	MHz											
20300	1745	1RB_High	Left	Touch	/	19.17	20.50	0.083	0.11	0.149	0.20	0.08
20300	1745	1RB_High	Left	Tilt	/	19.17	20.50	0.083	0.11	0.159	0.22	0.02
20300	1745	1RB_High	Right	Touch	Fig.13	19.17	20.50	0.258	0.35	0.494	0.67	-0.07
20300	1745	1RB_High	Right	Tilt	/	19.17	20.50	0.199	0.27	0.422	0.57	-0.08
20300	1745	50RB_High	Left	Touch	/	19.26	20.50	0.064	0.09	0.113	0.15	-0.05
20300	1745	50RB_High	Left	Tilt	/	19.26	20.50	0.055	0.07	0.106	0.14	0.10
20300	1745	50RB_High	Right	Touch	/	19.26	20.50	0.127	0.17	0.245	0.33	-0.11
20300	1745	50RB_High	Right	Tilt	/	19.26	20.50	0.091	0.12	0.196	0.26	-0.09

Note1: The LTE mode is QPSK_20MHz.

Table 14.1-14: SAR Values (LTE Band2 - Body)

Ambient Temperature: 22.9 °C						Liquid Temperature: 22.5 °C					
Frequency		Mode	Test Position	Figure No.	Conduct ed Power (dBm)	Max. tune-up Power (dBm)	Measured SAR(10g) (W/kg)	Reported SAR(10g) (W/kg)	Measured SAR(1g) (W/kg)	Reported SAR(1g) (W/kg)	Power Drift (dB)
Ch.	MHz										
20300	1745	1RB_High	Front	/	23.06	24.00	0.06	0.07	0.098	0.12	-0.01
20300	1745	1RB_High	Rear	/	23.06	24.00	0.067	0.08	0.107	0.13	0.04
20300	1745	1RB_High	Left	Fig.14	23.06	24.00	0.098	0.12	0.181	0.22	-0.12
20300	1745	1RB_High	Top	/	23.06	24.00	0.094	0.12	0.177	0.22	0.01
20300	1745	50RB_High	Front	/	22.11	23.00	0.045	0.06	0.073	0.09	-0.07
20300	1745	50RB_High	Rear	/	22.11	23.00	0.06	0.07	0.101	0.12	-0.05
20300	1745	50RB_High	Left	/	22.11	23.00	0.089	0.11	0.161	0.20	-0.05
20300	1745	50RB_High	Top	/	22.11	23.00	0.077	0.09	0.143	0.18	0.11

Note1: The distance between the EUT and the phantom bottom is 10mm

Note2: The LTE mode is QPSK_20MHz.

Table 14.1-15: SAR Values (LTE Band5 - Head)

Ambient Temperature: 22.9 °C						Liquid Temperature: 22.5 °C						
Frequency		Mode	Side	Test Position	Figure No.	Conducted Power (dBm)	Max. tune-up Power (dBm)	Measured SAR(10g) (W/kg)	Reported SAR(10g) (W/kg)	Measured SAR(1g) (W/kg)	Reported SAR(1g) (W/kg)	Power Drift (dB)
Ch.	MHz											
20450	829	1RB_High	Left	Touch	/	18.11	20.00	0.096	0.15	0.186	0.29	0.05
20450	829	1RB_High	Left	Tilt	/	18.11	20.00	0.095	0.15	0.192	0.30	-0.03
20450	829	1RB_High	Right	Touch	/	18.11	20.00	0.227	0.35	0.469	0.72	-0.06
20450	829	1RB_High	Right	Tilt	Fig.15	18.11	20.00	0.239	0.37	0.514	0.79	0.04
20450	829	25RB_Mid	Left	Touch	/	18.22	20.00	0.071	0.11	0.137	0.21	-0.09
20450	829	25RB_Mid	Left	Tilt	/	18.22	20.00	0.070	0.11	0.140	0.21	0.14
20450	829	25RB_Mid	Right	Touch	/	18.22	20.00	0.169	0.25	0.353	0.53	-0.03
20450	829	25RB_Mid	Right	Tilt	/	18.22	20.00	0.178	0.27	0.380	0.57	0.06

Note1: The LTE mode is QPSK_10MHz.

Table 14.1-16: SAR Values (LTE Band5 - Body)

Ambient Temperature: 22.9 °C						Liquid Temperature: 22.5 °C					
Frequency		Mode	Test Position	Figure No.	Conducted Power (dBm)	Max. tune-up Power (dBm)	Measured SAR(10g) (W/kg)	Reported SAR(10g) (W/kg)	Measured SAR(1g) (W/kg)	Reported SAR(1g) (W/kg)	Power Drift (dB)
Ch.	MHz										
20450	829	1RB_High	Front	/	22.63	24.00	0.099	0.14	0.183	0.25	0.11
20450	829	1RB_High	Rear	/	22.63	24.00	0.087	0.12	0.156	0.21	0.09
20450	829	1RB_High	Left	Fig.16	22.63	24.00	0.074	0.10	0.180	0.25	-0.01
20450	829	1RB_High	Top	/	22.63	24.00	0.074	0.10	0.164	0.22	0.08
20450	829	25RB_Mid	Front	/	21.77	23.00	0.074	0.10	0.136	0.18	-0.01
20450	829	25RB_Mid	Rear	/	21.77	23.00	0.064	0.08	0.116	0.15	-0.10
20450	829	25RB_Mid	Left	/	21.77	23.00	0.055	0.07	0.134	0.18	-0.12
20450	829	25RB_Mid	Top	/	21.77	23.00	0.055	0.07	0.123	0.16	0.04
20450	829	1RB_High	Left	J1	22.63	24.00	0.070	0.10	0.167	0.23	0.03
20450	829	1RB_High	Left	B1	22.63	24.00	0.059	0.08	0.142	0.19	0.07

Note1: The distance between the EUT and the phantom bottom is 10mm.

Note2: The LTE mode is QPSK_10MHz.

Table 14.1-17: SAR Values (LTE Band7 - Head)

Ambient Temperature: 22.9 °C						Liquid Temperature: 22.5 °C						
Frequency		Mode	Side	Test Position	Figure No.	Conducted Power (dBm)	Max. tune-up Power (dBm)	Measured SAR(10g) (W/kg)	Reported SAR(10g) (W/kg)	Measured SAR(1g) (W/kg)	Reported SAR(1g) (W/kg)	Power Drift (dB)
Ch.	MHz											
21100	2535	1RB_Low	Left	Touch	/	17.81	19.50	0.095	0.14	0.204	0.30	0.05
21100	2535	1RB_Low	Left	Tilt	/	17.81	19.50	0.082	0.12	0.188	0.28	-0.12

21350	2560	1RB_Low	Right	Touch	/	17.78	19.50	0.246	0.37	0.607	0.90	0.07
21100	2535	1RB_Low	Right	Touch	Fig.17	17.81	19.50	0.255	0.38	0.621	0.92	0.16
20850	2510	1RB_Low	Right	Touch	/	17.79	19.50	0.228	0.34	0.589	0.87	0.09
21100	2535	1RB_Low	Right	Tilt	/	17.81	19.50	0.159	0.23	0.363	0.54	0.12
20850	2510	50RB_Mid	Left	Touch	/	17.97	19.50	0.076	0.11	0.160	0.23	-0.07
20850	2510	50RB_Mid	Left	Tilt	/	17.97	19.50	0.067	0.10	0.155	0.22	0.03
21350	2560	50RB_Mid	Right	Touch	/	17.77	19.50	0.231	0.34	0.579	0.86	0.07
21100	2535	50RB_Mid	Right	Touch	/	17.87	19.50	0.211	0.31	0.534	0.78	0.09
20850	2510	50RB_Mid	Right	Touch	/	17.97	19.50	0.240	0.34	0.599	0.85	-0.07
20850	2510	50RB_Mid	Right	Tilt	/	17.97	19.50	0.133	0.19	0.308	0.44	0.19
20850	2510	100RB	Right	Touch	/	17.92	19.50	0.203	0.29	0.496	0.71	0.07
21350	2560	1RB_Low	Right	Touch	UL CA	17.70	19.50	0.219	0.33	0.537	0.81	0.07
21100	2535	1RB_Low	Right	Touch	J1	17.81	19.50	0.218	0.32	0.573	0.85	0.14
21100	2535	1RB_Low	Right	Touch	B1	17.81	19.50	0.239	0.35	0.601	0.89	-0.07

Note1: The LTE mode is QPSK_20MHz.

Table 14.1-18: SAR Values (LTE Band7 - Body)

Ambient Temperature: 22.9°C						Liquid Temperature: 22.5°C					
Frequency		Mode	Test Position	Figure No.	Conduc ted Power (dBm)	Max. tune-up Power (dBm)	Measured SAR(10g) (W/kg)	Reported SAR(10g) (W/kg)	Measured SAR(1g) (W/kg)	Reported SAR(1g) (W/kg)	Power Drift (dB)
Ch.	MHz										
21100	2535	1RB_Low	Front	/	21.41	22.00	0.131	0.15	0.228	0.26	0.00
21100	2535	1RB_Low	Rear	/	21.41	22.00	0.147	0.17	0.243	0.28	-0.03
21350	2560	1RB_Low	Left	/	21.10	22.00	0.294	0.36	0.637	0.78	0.03
21100	2535	1RB_Low	Left	Fig.18	21.41	22.00	0.313	0.36	0.695	0.80	0.09
20850	2510	1RB_Low	Left	/	21.25	22.00	0.286	0.34	0.621	0.74	0.03
21100	2535	1RB_Low	Top	/	21.41	22.00	0.057	0.07	0.105	0.12	-0.03
20850	2510	50RB_Mid	Front	/	20.30	21.00	0.108	0.13	0.189	0.22	0.02
20850	2510	50RB_Mid	Rear	/	20.30	21.00	0.127	0.15	0.227	0.27	0.12
20850	2510	50RB_Mid	Left	/	20.30	21.00	0.265	0.31	0.550	0.65	0.13
20850	2510	50RB_Mid	Top	/	20.30	21.00	0.053	0.06	0.100	0.12	0.01
20850	2510	100RB	Left	/	20.33	21.00	0.221	0.26	0.533	0.62	0.08
21350	2560	1RB_Low	Left	ULCA	21.22	22.00	0.171	0.20	0.391	0.47	-0.16
21100	2535	1RB_Low	Left	J1	21.41	22.00	0.286	0.33	0.620	0.71	0.04
21100	2535	1RB_Low	Left	B1	21.41	22.00	0.297	0.34	0.648	0.74	0.00

Note1: The distance between the EUT and the phantom bottom is 10mm

Note2: The LTE mode is QPSK_20MHz.

Table 14.1-19: SAR Values (LTE Band38 - Head)

Frequency		Mode	Side	Test Position	Figure No.	Ambient Temperature: 22.9 °C		Liquid Temperature: 22.5 °C				Power Drift (dB)
Ch.	MHz					Conducted Power (dBm)	Max. tune-up Power (dBm)	Measured SAR(10g) (W/kg)	Reported SAR(10g) (W/kg)	Measured SAR(1g) (W/kg)	Reported SAR(1g) (W/kg)	
38150	2610	1RB_High	Left	Touch	/	17.77	19.50	0.089	0.13	0.212	0.32	0.05
38150	2610	1RB_High	Left	Tilt	/	17.77	19.50	0.071	0.11	0.176	0.26	-0.04
38150	2610	1RB_High	Right	Touch	Fig.19	17.77	19.50	0.245	0.36	0.663	0.99	0.03
38000	2595	1RB-Mid	Right	Touch		17.75	19.50	0.223	0.33	0.617	0.92	0.06
37850	2580	1RB_Low	Right	Touch		17.73	19.50	0.209	0.31	0.604	0.91	-0.03
38150	2610	1RB_High	Right	Tilt	/	17.77	19.50	0.166	0.25	0.492	0.73	-0.09
38000	2595	50RB_Mid	Left	Touch	/	17.83	19.50	0.064	0.09	0.148	0.22	0.11
38000	2595	50RB_Mid	Left	Tilt	/	17.83	19.50	0.052	0.08	0.126	0.19	0.04
38000	2595	50RB_Mid	Right	Touch	/	17.83	19.50	0.200	0.29	0.480	0.71	-0.01
38000	2595	50RB_Mid	Right	Tilt	/	17.83	19.50	0.114	0.17	0.320	0.47	0.04
38000	2595	100RB	Right	Touch		17.81	19.50	0.186	0.27	0.437	0.64	-0.07
38150	2610	1RB_High	Right	Touch	UL CA	17.63	19.50	0.179	0.28	0.537	0.83	0.07

Note1: The LTE mode is QPSK_20MHz.

Table 14.1-20: SAR Values (LTE Band38 - Body)

Frequency		Mode	Test Position	Figure No.	Ambient Temperature: 22.9 °C		Liquid Temperature: 22.5 °C				Power Drift (dB)
Ch.	MHz				Conducted Power (dBm)	Max. tune-up Power (dBm)	Measured SAR(10g) (W/kg)	Reported SAR(10g) (W/kg)	Measured SAR(1g) (W/kg)	Reported SAR(1g) (W/kg)	
38150	2610	1RB_High	Front	/	22.86	24.00	0.090	0.12	0.154	0.20	0.00
38150	2610	1RB_High	Rear	/	22.86	24.00	0.088	0.11	0.152	0.20	0.04
38150	2610	1RB_High	Left	Fig.20	22.86	24.00	0.170	0.22	0.398	0.52	0.02
38150	2610	1RB_High	Top	/	22.86	24.00	0.030	0.04	0.051	0.07	0.03
38000	2595	50RB_Mid	Front	/	21.97	23.00	0.066	0.08	0.115	0.15	0.13
38000	2595	50RB_Mid	Rear	/	21.97	23.00	0.065	0.08	0.116	0.15	0.10
38000	2595	50RB_Mid	Left	/	21.97	23.00	0.128	0.16	0.266	0.34	-0.07
38000	2595	50RB_Mid	Top	/	21.97	23.00	0.023	0.03	0.038	0.05	-0.07
38150	2610	1RB_High	Left	UL CA	22.61	24.00	0.143	0.20	0.317	0.44	0.07

Note1: The distance between the EUT and the phantom bottom is 10mm.

Note2: The LTE mode is QPSK_20MHz.

14.2 SAR results for Main antenna

Table 14.2-1: SAR Values (GSM 1900 MHz Band - Head)

Ambient Temperature: 22.9 °C						Liquid Temperature: 22.5°C					
Frequency		Side	Test Position	Figure No.	Conducted Power (dBm)	Max. tune-up Power (dBm)	Measured SAR(10g) (W/kg)	Reported SAR(10g) (W/kg)	Measured SAR(1g) (W/kg)	Reported SAR(1g) (W/kg)	Power Drift (dB)
Ch.	MHz										
661	1880	Left	Touch	/	29.69	30.5	0.013	0.02	0.021	0.03	0.05
661	1880	Left	Tilt	/	29.69	30.5	0.025	0.03	0.047	0.06	0.14
810	1909.8	Right	Touch	/	29.56	30.5	0.033	0.04	0.060	0.07	0.03
661	1880	Right	Touch	/	29.69	30.5	0.034	0.04	0.075	0.09	0.05
512	1850.2	Right	Touch	Fig.21	29.43	30.5	0.049	0.06	0.083	0.11	0.07
661	1880	Right	Tilt	/	29.69	30.5	0.023	0.03	0.042	0.05	0.08

Table 14.2-2: SAR Values (GSM 1900 MHz Band - Body)

Ambient Temperature: 22.9 °C						Liquid Temperature: 22.5°C					
Frequency		Mode (number of timeslots)	Test Position	Figure No.	Conducted Power (dBm)	Max. tune-up Power (dBm)	Measured SAR(10g) (W/kg)	Reported SAR(10g) (W/kg)	Measured SAR(1g) (W/kg)	Reported SAR(1g) (W/kg)	Power Drift (dB)
Ch.	MHz										
661	1880	GPRS (1)	Front	/	27.28	28	0.167	0.20	0.338	0.40	0.10
661	1880	GPRS (1)	Rear	/	27.28	28	0.163	0.19	0.330	0.39	-0.05
661	1880	GPRS (1)	Left	/	27.28	28	0.015	0.02	0.030	0.04	0.12
661	1880	GPRS (1)	Right	/	27.28	28	0.019	0.02	0.034	0.04	-0.13
810	1909.8	GPRS (1)	Bottom	/	27.09	28	0.364	0.45	0.741	0.91	0.09
661	1880	GPRS (1)	Bottom	/	27.28	28	0.349	0.41	0.712	0.84	0.12
512	1850.2	GPRS (1)	Bottom	Fig.22	27.27	28	0.366	0.43	0.747	0.88	-0.03
512	1850.2	EGPRS (1)	Bottom	/	27.37	28	0.361	0.42	0.700	0.81	-0.03

Note1: The distance between the EUT and the phantom bottom is 10mm

Table 14.2-3: SAR Values (WCDMA 1900 MHz Band - Head)

Ambient Temperature: 22.9 °C						Liquid Temperature: 22.5°C					
Frequency		Side	Test Position	Figure No.	Conducted Power (dBm)	Max. tune-up Power (dBm)	Measured SAR(10g) (W/kg)	Reported SAR(10g) (W/kg)	Measured SAR(1g) (W/kg)	Reported SAR(1g) (W/kg)	Power Drift (dB)
Ch.	MHz										
9800	1880	Left	Touch	/	23.78	25	0.075	0.10	0.111	0.15	-0.01
9800	1880	Left	Tilt	/	23.78	25	0.069	0.09	0.110	0.15	0.13
9938	1907.6	Right	Touch	/	23.76	25	0.076	0.10	0.118	0.16	0.10
9800	1880	Right	Touch	/	23.78	25	0.101	0.13	0.158	0.21	-0.06
9662	1852.4	Right	Touch	Fig.23	23.72	25	0.106	0.14	0.168	0.23	0.07
9800	1880	Right	Tilt	/	23.78	25	0.060	0.08	0.097	0.13	-0.05
9662	1852.4	Right	Touch	J1	23.72	25	0.097	0.13	0.143	0.19	0.09
9662	1852.4	Right	Touch	B1	23.72	25	0.100	0.13	0.143	0.19	0.07

Table 14.2-4: SAR Values (WCDMA 1900 MHz Band - Body)

Frequency		Test Position	Figure No.	Ambient Temperature: 22.9 °C		Liquid Temperature: 22.5 °C				Power Drift (dB)
Ch.	MHz			Conducted Power (dBm)	Max. tune-up Power (dBm)	Measured SAR(10g) (W/kg)	Reported SAR(10g) (W/kg)	Measured SAR(1g) (W/kg)	Reported SAR(1g) (W/kg)	
9800	1880	Front	/	16.79	18	0.153	0.20	0.303	0.40	-0.05
9800	1880	Rear	/	16.79	18	0.165	0.22	0.312	0.41	-0.01
9800	1880	Left	/	16.79	18	0.013	0.02	0.023	0.03	-0.01
9800	1880	Right	/	16.79	18	0.017	0.02	0.027	0.04	0.09
9938	1907.6	Bottom	/	16.82	18	0.333	0.44	0.665	0.87	0.06
9800	1880	Bottom	/	16.79	18	0.347	0.46	0.696	0.92	0.04
9662	1852.4	Bottom	Fig.24	16.83	18	0.356	0.47	0.713	0.93	0.08
9662	1852.4	Bottom	Note2	19.72	21	1.24	1.67	2.88	3.87	-0.06
9662	1852.4	Bottom	Note2	19.72	21	1.27	1.71	2.91	3.91	0.15
9662	1852.4	Bottom	Note2	19.72	21	0.614	0.82	1.49	2.00	0.03

Note1: The distance between the EUT and the phantom bottom is 10mm

Note2: The distance between the EUT and the phantom bottom is 0mm

Table 14.2-5: SAR Values (WCDMA 1900 MHz Band - Body)

Frequency		Test Position	Figure No.	Ambient Temperature: 22.9 °C		Liquid Temperature: 22.5 °C				Power Drift (dB)
Ch.	MHz			Conducted Power (dBm)	Max. tune-up Power (dBm)	Measured SAR(10g) (W/kg)	Reported SAR(10g) (W/kg)	Measured SAR(1g) (W/kg)	Reported SAR(1g) (W/kg)	
9938	1907.6	Front	/	23.76	25	0.411	0.55	0.748	1.00	-0.07
9800	1880	Front	/	23.78	25	0.374	0.50	0.668	0.88	-0.08
9662	1852.4	Front	Fig.25	23.72	25	0.421	0.57	0.757	1.02	-0.02
9938	1907.6	Rear	/	23.76	25	0.356	0.47	0.589	0.78	-0.06
9800	1880	Rear	/	23.78	25	0.403	0.53	0.689	0.91	-0.13
9662	1852.4	Rear	/	23.72	25	0.407	0.55	0.694	0.93	0.12
9662	1852.4	Front	J1	23.72	25	0.379	0.51	0.711	0.95	0.03
9662	1852.4	Front	B1	23.72	25	0.394	0.53	0.728	0.98	0.07

Note1: The distance between the EUT and the phantom bottom is 15mm

Table 14.2-6: SAR Values (WCDMA 1700 MHz Band - Head)

Frequency		Side	Test Position	Figure No.	Ambient Temperature: 22.9 °C		Liquid Temperature: 22.5 °C				Power Drift (dB)
Ch.	MHz				Conducted Power (dBm)	Max. tune-up Power (dBm)	Measured SAR(10g) (W/kg)	Reported SAR(10g) (W/kg)	Measured SAR(1g) (W/kg)	Reported SAR(1g) (W/kg)	
1412	1732.4	Left	Touch	/	23.84	25	0.048	0.06	0.073	0.10	0.13
1412	1732.4	Left	Tilt	/	23.84	25	0.041	0.05	0.067	0.09	0.00
1513	1752.6	Right	Touch	/	23.86	25	0.084	0.11	0.132	0.17	0.12
1412	1732.4	Right	Touch	Fig.26	23.84	25	0.095	0.12	0.152	0.20	-0.08

1312	1712.4	Right	Touch	/	23.64	25	0.083	0.11	0.133	0.18	-0.10
1412	1732.4	Right	Tilt	/	23.84	25	0.046	0.06	0.082	0.11	-0.13

Table 14.2-7: SAR Values (WCDMA 1700 MHz Band - Body)

Ambient Temperature: 22.9°C						Liquid Temperature: 22.5°C				
Frequency		Test Position	Figure No.	Conducted Power (dBm)	Max. tune-up Power (dBm)	Measured SAR(10g) (W/kg)	Reported SAR(10g) (W/kg)	Measured SAR(1g) (W/kg)	Reported SAR(1g) (W/kg)	Power Drift (dB)
Ch.	MHz									
1412	1732.5	Front	/	17.31	18.5	0.199	0.26	0.390	0.51	-0.07
1412	1732.5	Rear	/	17.31	18.5	0.196	0.26	0.371	0.49	-0.10
1412	1732.5	Left	/	17.31	18.5	0.019	0.02	0.034	0.04	0.06
1412	1732.5	Right	/	17.31	18.5	0.014	0.02	0.023	0.03	0.08
1513	1752.6	Bottom	Fig.27	17.36	18.5	0.377	0.49	0.745	0.97	-0.02
1412	1732.5	Bottom	/	17.31	18.5	0.345	0.45	0.691	0.91	-0.12
1312	1712.4	Bottom	/	17.23	18.5	0.292	0.39	0.569	0.76	-0.09
1513	1752.6	Front	Note2	19.85	21	1.72	2.24	3.92	5.11	-0.03
1412	1732.5	Front	Note2	19.83	21	1.77	2.32	4.42	5.79	0.05
1312	1712.4	Front	Note2	19.78	21	1.59	2.11	3.51	4.65	0.05
1513	1752.6	Rear	Note2	19.85	21	1.37	1.79	3.29	4.29	0.07
1412	1732.5	Rear	Note2	19.83	21	1.68	2.20	3.80	4.97	0.07
1312	1712.4	Rear	Note2	19.78	21	1.32	1.75	3.11	4.12	-0.19
1513	1752.6	Bottom	Note2	19.83	21	0.648	0.85	1.60	2.09	0.18
1513	1752.6	Bottom	J1	17.36	18.5	0.344	0.45	0.714	0.93	0.06
1513	1752.6	Bottom	B1	17.36	18.5	0.317	0.41	0.691	0.90	0.17

Note1: The distance between the EUT and the phantom bottom is 10mm

Note2: The distance between the EUT and the phantom bottom is 0mm

Table 14.2-8: SAR Values (WCDMA 1700 MHz Band - Body)

Ambient Temperature: 22.9°C						Liquid Temperature: 22.5°C				
Frequency		Test Position	Figure No.	Conducted Power (dBm)	Max. tune-up Power (dBm)	Measured SAR(10g) (W/kg)	Reported SAR(10g) (W/kg)	Measured SAR(1g) (W/kg)	Reported SAR(1g) (W/kg)	Power Drift (dB)
Ch.	MHz									
1513	1752.6	Front	Fig.28	23.86	25	0.419	0.54	0.739	0.96	-0.03
1412	1732.5	Front	/	23.84	25	0.408	0.53	0.734	0.96	0.02
1312	1712.4	Front	/	23.64	25	0.303	0.41	0.581	0.79	-0.03
1513	1752.6	Rear	/	23.86	25	0.415	0.54	0.724	0.94	0.02
1412	1732.5	Rear	/	23.84	25	0.402	0.53	0.698	0.91	0.01
1312	1712.4	Rear	/	23.64	25	0.344	0.47	0.596	0.82	-0.10

Note1: The distance between the EUT and the phantom bottom is 15mm

Table 14.2-9: SAR Values (WCDMA 850 MHz Band - Head)

Ambient Temperature: 22.9 °C						Liquid Temperature: 22.5 °C					
Frequency		Side	Test Position	Figure No.	Conducted Power (dBm)	Max. tune-up Power (dBm)	Measured SAR(10g) (W/kg)	Reported SAR(10g) (W/kg)	Measured SAR(1g) (W/kg)	Reported SAR(1g) (W/kg)	Power Drift (dB)
Ch.	MHz										
4233	846.6	Left	Touch	Fig.29	23.94	25	0.143	0.18	0.187	0.24	0.04
4182	836.4	Left	Touch	/	23.95	25	0.138	0.18	0.179	0.23	-0.11
4132	826.4	Left	Touch	/	23.79	25	0.127	0.17	0.166	0.22	0.02
4182	836.4	Left	Tilt	/	23.95	25	0.085	0.11	0.106	0.13	-0.06
4182	836.4	Right	Touch	/	23.95	25	0.094	0.12	0.118	0.15	0.10
4182	836.4	Right	Tilt	/	23.95	25	0.083	0.11	0.111	0.14	-0.13

Table 14.2-10: SAR Values (WCDMA 850 MHz Band - Body)

Ambient Temperature: 22.9 °C						Liquid Temperature: 22.5 °C					
Frequency		Test Position	Figure No.	Conducted Power (dBm)	Max. tune-up Power (dBm)	Measured SAR(10g) (W/kg)	Reported SAR(10g) (W/kg)	Measured SAR(1g) (W/kg)	Reported SAR(1g) (W/kg)	Power Drift (dB)	
Ch.	MHz										
4182	836.4	Front	/	23.95	25	0.135	0.17	0.259	0.33	-0.10	
4233	846.6	Rear	/	23.94	25	0.146	0.19	0.283	0.36	-0.13	
4182	836.4	Rear	Fig.30	23.95	25	0.146	0.19	0.286	0.36	0.00	
4132	826.4	Rear	/	23.79	25	0.131	0.17	0.255	0.34	0.06	
4182	836.4	Left	/	23.95	25	0.042	0.05	0.073	0.09	-0.11	
4182	836.4	Right	/	23.95	25	0.028	0.04	0.050	0.06	-0.05	
4182	836.4	Bottom	/	23.95	25	0.066	0.08	0.161	0.21	-0.02	

Note: The distance between the EUT and the phantom bottom is 10mm.

Table 14.2-11: SAR Values (LTE Band2 - Head)

Ambient Temperature: 22.9 °C						Liquid Temperature: 22.5 °C						
Frequency		Mode	Side	Test Position	Figure No.	Conducted Power (dBm)	Max. tune-up Power (dBm)	Measured SAR(10g) (W/kg)	Reported SAR(10g) (W/kg)	Measured SAR(1g) (W/kg)	Reported SAR(1g) (W/kg)	Power Drift (dB)
Ch.	MHz											
19100	1900	1RB_High	Left	Touch	/	22.69	24	0.046	0.06	0.072	0.10	-0.11
19100	1900	1RB_High	Left	Tilt	/	22.69	24	0.041	0.06	0.071	0.10	0.05
19100	1900	1RB_High	Right	Touch	Fig.31	22.69	24	0.063	0.09	0.102	0.14	0.09
19100	1900	1RB_High	Right	Tilt	/	22.69	24	0.030	0.04	0.050	0.07	-0.09
18700	1860	50RB_Mid	Left	Touch	/	21.83	23	0.047	0.06	0.072	0.09	-0.09
18700	1860	50RB_Mid	Left	Tilt	/	21.83	23	0.039	0.05	0.067	0.09	0.04
18700	1860	50RB_Mid	Right	Touch	/	21.83	23	0.054	0.07	0.088	0.12	0.07
18700	1860	50RB_Mid	Right	Tilt	/	21.83	23	0.045	0.06	0.076	0.10	0.00

Note1: The LTE mode is QPSK_20MHz.

Table 14.2-12: SAR Values (LTE Band2 - Body)

Frequency		Mode	Test Position	Figure No.	Conduct ed Power (dBm)	Max. tune-up Power (dBm)	Ambient Temperature: 22.9 °C		Liquid Temperature: 22.5°C		Power Drift (dB)
Ch.	MHz						Measured SAR(10g) (W/kg)	Reported SAR(10g) (W/kg)	Measured SAR(1g) (W/kg)	Reported SAR(1g) (W/kg)	
19100	1900	1RB_High	Front	/	16.77	18	0.133	0.18	0.259	0.34	0.13
19100	1900	1RB_High	Rear	/	16.77	18	0.148	0.20	0.280	0.37	-0.11
19100	1900	1RB_High	Left	/	16.77	18	0.011	0.01	0.020	0.03	0.06
19100	1900	1RB_High	Right	/	16.77	18	0.012	0.02	0.020	0.03	0.05
19100	1900	1RB_High	Bottom	Fig.32	16.77	18	0.350	0.46	0.697	0.93	-0.13
18900	1880	1RB_Mid	Bottom	/	16.68	18	0.327	0.44	0.642	0.87	0.05
18700	1860	1RB_Low	Bottom	/	16.76	18	0.319	0.42	0.601	0.80	-0.07
18700	1860	50RB_Mid	Front	/	16.86	18	0.133	0.17	0.264	0.34	-0.11
18700	1860	50RB_Mid	Rear	/	16.86	18	0.139	0.18	0.263	0.34	-0.12
18700	1860	50RB_Mid	Left	/	16.86	18	0.010	0.01	0.018	0.02	0.06
18700	1860	50RB_Mid	Right	/	16.86	18	0.013	0.02	0.021	0.03	0.03
18700	1860	50RB_Mid	Bottom	/	16.86	18	0.286	0.37	0.579	0.75	-0.10
18900	1880	100RB	Bottom	/	16.88	18	0.274	0.35	0.561	0.73	0.06
19100	1900	1RB_High	Bottom	Note2	19.68	21	0.590	0.80	1.390	1.88	0.02

Note1: The distance between the EUT and the phantom bottom is 10mm

Note2: The distance between the EUT and the phantom bottom is 0mm

Note3: The LTE mode is QPSK_20MHz.

Table 14.2-13: SAR Values (LTE Band2 - Body)

Frequency		Mode	Test Position	Figure No.	Conduct ed Power (dBm)	Max. tune-up Power (dBm)	Ambient Temperature: 22.9 °C		Liquid Temperature: 22.5°C		Power Drift (dB)
Ch.	MHz						Measured SAR(10g) (W/kg)	Reported SAR(10g) (W/kg)	Measured SAR(1g) (W/kg)	Reported SAR(1g) (W/kg)	
19100	1900	1RB_High	Front	Fig.33	22.69	24	0.347	0.47	0.628	0.85	-0.09
18900	1880	1RB_High	Front	/	22.68	24	0.315	0.43	0.561	0.76	-0.11
18700	1860	1RB_Low	Front	/	22.68	24	0.280	0.38	0.501	0.68	0.04
19100	1900	1RB_High	Rear	/	22.69	24	0.312	0.42	0.541	0.73	-0.13
18700	1860	50RB_Mid	Front	/	21.83	23	0.280	0.37	0.510	0.67	0.12
18700	1860	50RB_Mid	Rear	/	21.83	23	0.293	0.38	0.508	0.67	0.11
18700	1860	100RB	Front	/	21.80	23	0.280	0.37	0.500	0.66	0.08

Note1: The distance between the EUT and the phantom bottom is 15mm

Note2: The LTE mode is QPSK_20MHz.

Table 14.2-14: SAR Values (LTE Band4 - Head)

Ambient Temperature: 22.9°C						Liquid Temperature: 22.5°C						
Frequency		Mode	Side	Test Position	Figure No.	Conducted Power (dBm)	Max. tune-up Power (dBm)	Measured SAR(10g) (W/kg)	Reported SAR(10g) (W/kg)	Measured SAR(1g) (W/kg)	Reported SAR(1g) (W/kg)	Power Drift (dB)
Ch.	MHz											
20300	1745	1RB_High	Left	Touch	/	23.06	24	0.042	0.05	0.066	0.08	-0.11
20300	1745	1RB_High	Left	Tilt	/	23.06	24	0.039	0.05	0.057	0.07	0.03
20300	1745	1RB_High	Right	Touch	Fig.34	23.06	24	0.056	0.07	0.089	0.11	-0.05
20300	1745	1RB_High	Right	Tilt	/	23.06	24	0.039	0.05	0.066	0.08	0.08
20300	1745	50RB_High	Left	Touch	/	22.11	23	0.037	0.05	0.054	0.07	0.01
20300	1745	50RB_High	Left	Tilt	/	22.11	23	0.034	0.04	0.046	0.06	0.09
20300	1745	50RB_High	Right	Touch	/	22.11	23	0.053	0.07	0.088	0.11	0.06
20300	1745	50RB_High	Right	Tilt	/	22.11	23	0.034	0.04	0.062	0.08	-0.11

Note1: The LTE mode is QPSK_20MHz.

Table 14.2-15: SAR Values (LTE Band4 - Body)

Ambient Temperature: 22.9°C						Liquid Temperature: 22.5°C					
Frequency		Mode	Test Position	Figure No.	Conduct ed Power (dBm)	Max. tune-up Power (dBm)	Measured SAR(10g) (W/kg)	Reported SAR(10g) (W/kg)	Measured SAR(1g) (W/kg)	Reported SAR(1g) (W/kg)	Power Drift (dB)
Ch.	MHz										
20300	1745	1RB_High	Front	/	17.33	18.5	0.191	0.25	0.378	0.49	0.11
20300	1745	1RB_High	Rear	/	17.33	18.5	0.197	0.26	0.371	0.49	0.12
20300	1745	1RB_High	Left	/	17.33	18.5	0.018	0.02	0.033	0.04	-0.12
20300	1745	1RB_High	Right	/	17.33	18.5	0.013	0.02	0.021	0.03	0.01
20300	1745	1RB_High	Bottom	Fig.35	17.33	18.5	0.354	0.46	0.697	0.91	0.02
20175	1732.5	1RB_High	Bottom	/	17.27	18.5	0.329	0.44	0.622	0.83	0.05
20300	1720	1RB_High	Bottom	/	17.14	18.5	0.301	0.41	0.577	0.79	-0.04
20300	1745	50RB_High	Front	/	17.35	18.5	0.159	0.21	0.313	0.41	0.01
20300	1745	50RB_High	Rear	/	17.35	18.5	0.154	0.20	0.289	0.38	0.03
20300	1745	50RB_High	Left	/	17.35	18.5	0.016	0.02	0.029	0.04	-0.01
20300	1745	50RB_High	Right	/	17.35	18.5	0.011	0.01	0.018	0.02	0.03
20300	1745	50RB_High	Bottom	/	17.35	18.5	0.310	0.40	0.608	0.79	0.04
20175	1732.5	100RB	Bottom	/	17.34	18.5	0.289	0.38	0.564	0.74	-0.13
20300	1745	1RB_High	Front	Note2	20.25	21.5	1.770	2.36	4.280	5.71	0.05
20175	1732.5	1RB_Mid	Front	Note2	20.18	21.5	1.510	2.05	3.680	4.99	0.07
20300	1720	1RB_Low	Front	Note2	20.16	21.5	1.430	1.95	3.190	4.34	-0.03
20300	1745	1RB_High	Rear	Note2	20.25	21.5	1.760	2.35	3.960	5.28	0.05
20175	1732.5	1RB_Mid	Rear	Note2	20.18	21.5	1.510	2.05	3.400	4.61	0.07
20300	1720	1RB_Low	Rear	Note2	20.16	21.5	1.440	1.96	2.950	4.02	0.12
20300	1745	1RB_High	Bottom	Note2	20.25	21.5	1.180	1.57	3.170	4.23	0.06

Note1: The distance between the EUT and the phantom bottom is 10mm

Note2: The distance between the EUT and the phantom bottom is 0mm

Note3: The LTE mode is QPSK_20MHz.

Table 14.2-16: SAR Values (LTE Band4 - Body)

Ambient Temperature: 22.9 °C						Liquid Temperature: 22.5°C					
Frequency		Mode	Test Position	Figure No.	Conducted Power (dBm)	Max. tune-up Power (dBm)	Measured SAR(10g) (W/kg)	Reported SAR(10g) (W/kg)	Measured SAR(1g) (W/kg)	Reported SAR(1g) (W/kg)	Power Drift (dB)
Ch.	MHz										
20300	1745	1RB_High	Front	Fig.36	23.06	24	0.296	0.37	0.528	0.66	0.03
20300	1745	1RB_High	Rear	/	23.06	24	0.305	0.38	0.518	0.64	-0.03
20300	1745	50RB_High	Front	/	22.11	23	0.246	0.30	0.438	0.54	0.04
20300	1745	50RB_High	Rear	/	22.11	23	0.238	0.29	0.405	0.50	0.04

Note1: The distance between the EUT and the phantom bottom is 15mm

Note2: The LTE mode is QPSK_20MHz.

Table 14.2-17: SAR Values (LTE Band5 - Head)

Ambient Temperature: 22.9 °C						Liquid Temperature: 22.5°C						
Frequency		Mode	Side	Test Position	Figure No.	Conducted Power (dBm)	Max. tune-up Power (dBm)	Measured SAR(10g) (W/kg)	Reported SAR(10g) (W/kg)	Measured SAR(1g) (W/kg)	Reported SAR(1g) (W/kg)	Power Drift (dB)
Ch.	MHz											
20450	829	1RB_High	Left	Touch	Fig.37	22.63	24	0.138	0.19	0.180	0.25	0.09
20450	829	1RB_High	Left	Tilt	/	22.63	24	0.083	0.11	0.106	0.15	-0.04
20450	829	1RB_High	Right	Touch	/	22.63	24	0.086	0.12	0.107	0.15	0.09
20450	829	1RB_High	Right	Tilt	/	22.63	24	0.076	0.10	0.105	0.14	0.02
20450	829	25RB_Mid	Left	Touch	/	21.77	23	0.110	0.15	0.145	0.19	-0.09
20450	829	25RB_Mid	Left	Tilt	/	21.77	23	0.068	0.09	0.086	0.11	0.07
20450	829	25RB_Mid	Right	Touch	/	21.77	23	0.068	0.09	0.085	0.11	-0.06
20450	829	25RB_Mid	Right	Tilt	/	21.77	23	0.062	0.08	0.082	0.11	-0.09

Note1: The LTE mode is QPSK_10MHz.

Table 14.2-18: SAR Values (LTE Band5 - Body)

Ambient Temperature: 22.9 °C						Liquid Temperature: 22.5°C					
Frequency		Mode	Test Position	Figure No.	Conducted Power (dBm)	Max. tune-up Power (dBm)	Measured SAR(10g) (W/kg)	Reported SAR(10g) (W/kg)	Measured SAR(1g) (W/kg)	Reported SAR(1g) (W/kg)	Power Drift (dB)
Ch.	MHz										
20450	829	1RB_High	Front	Fig.38	22.63	24	0.182	0.25	0.302	0.41	-0.12
20450	829	1RB_High	Rear	/	22.63	24	0.170	0.23	0.274	0.38	0.06
20450	829	1RB_High	Left	/	22.63	24	0.042	0.06	0.065	0.09	0.11
20450	829	1RB_High	Right	/	22.63	24	0.031	0.04	0.047	0.06	0.12
20450	829	1RB_High	Bottom	/	22.63	24	0.114	0.16	0.267	0.37	0.11

20450	829	25RB_Mid	Front	/	21.77	23	0.150	0.20	0.247	0.33	0.06
20450	829	25RB_Mid	Rear	/	21.77	23	0.142	0.19	0.231	0.31	0.06
20450	829	25RB_Mid	Left	/	21.77	23	0.033	0.04	0.052	0.07	-0.06
20450	829	25RB_Mid	Right	/	21.77	23	0.025	0.03	0.037	0.05	-0.11
20450	829	25RB_Mid	Bottom	/	21.77	23	0.088	0.12	0.184	0.24	-0.05

Note1: The distance between the EUT and the phantom bottom is 10mm.

Note2: The LTE mode is QPSK_10MHz.

Table 14.2-19: SAR Values (LTE Band7 - Head)

Ambient Temperature: 22.9°C Liquid Temperature: 22.5°C

Frequency		Mode	Side	Test Position	Figure No.	Conducted Power (dBm)	Max. tune-up Power (dBm)	Measured SAR(10g) (W/kg)	Reported SAR(10g) (W/kg)	Measured SAR(1g) (W/kg)	Reported SAR(1g) (W/kg)	Power Drift (dB)
Ch.	MHz											
21100	2535	1RB_Low	Left	Touch	/	22.92	24	0.045	0.06	0.078	0.10	0.04
21100	2535	1RB_Low	Left	Tilt	/	22.92	24	0.054	0.07	0.100	0.13	-0.01
21100	2535	1RB_Low	Right	Touch	Fig.99	22.92	24	0.058	0.07	0.103	0.13	0.04
21100	2535	1RB_Low	Right	Tilt	/	22.92	24	0.037	0.05	0.066	0.08	0.01
20850	2510	50RB_Mid	Left	Touch	/	22.00	23	0.042	0.05	0.073	0.09	0.13
20850	2510	50RB_Mid	Left	Tilt	/	22.00	23	0.042	0.05	0.078	0.10	-0.01
20850	2510	50RB_Mid	Right	Touch	/	22.00	23	0.044	0.06	0.078	0.10	-0.09
20850	2510	50RB_Mid	Right	Tilt	/	22.00	23	0.025	0.03	0.042	0.05	-0.13
20850	2510	100RB	Right	Touch	/	22.59	23	0.047	0.05	0.089	0.10	-0.17
21350	2560	1RB_Low	Right	Touch	UL CA	22.92	24	0.045	0.06	0.078	0.10	0.04

Note1: The LTE mode is QPSK_20MHz.

Table 14.2-20: SAR Values (LTE Band7 - Body)

Ambient Temperature: 22.9°C Liquid Temperature: 22.5°C

Frequency		Mode	Test Position	Figure No.	Conducted Power (dBm)	Max. tune-up Power (dBm)	Measured SAR(10g) (W/kg)	Reported SAR(10g) (W/kg)	Measured SAR(1g) (W/kg)	Reported SAR(1g) (W/kg)	Power Drift (dB)
Ch.	MHz										
21100	2535	1RB_Low	Front	/	20.02	21	0.185	0.23	0.326	0.41	-0.02
21100	2535	1RB_Low	Rear	/	20.02	21	0.217	0.27	0.388	0.49	0.10
21100	2535	1RB_Low	Left	/	20.02	21	0.041	0.05	0.063	0.08	-0.07
21100	2535	1RB_Low	Right	/	20.02	21	0.054	0.07	0.090	0.11	-0.06
21100	2535	1RB_Low	Bottom	Fig.40	20.02	21	0.289	0.36	0.626	0.78	0.02
20850	2510	50RB_Mid	Front	/	20.10	21	0.164	0.20	0.318	0.39	0.07
20850	2510	50RB_Mid	Rear	/	20.10	21	0.180	0.22	0.350	0.43	-0.04
20850	2510	50RB_Mid	Left	/	20.10	21	0.040	0.05	0.064	0.08	-0.13
20850	2510	50RB_Mid	Right	/	20.10	21	0.042	0.05	0.072	0.09	-0.05
20850	2510	50RB_Mid	Bottom	/	20.10	21	0.243	0.30	0.476	0.59	0.05
21350	2560	1RB_Low	Bottom	Note2	19.77	21	1.640	2.18	5.370	7.13	0.05

21100	2535	1RB_Low	Bottom	Note2	19.89	21	1.700	2.20	5.450	7.04	0.09
20850	2510	1RB_High	Bottom	Note2	19.82	21	1.640	2.15	5.350	7.02	0.01
21350	2560	1RB_Low	Bottom	UL CA	19.89	21	0.256	0.33	0.597	0.77	-0.05

Note1: The distance between the EUT and the phantom bottom is 10mm

Note2: The distance between the EUT and the phantom bottom is 0mm

Note3: The LTE mode is QPSK_20MHz.

Table 14.2-21: SAR Values (LTE Band7 - Body)

Ambient Temperature: 22.9 °C						Liquid Temperature: 22.5 °C					
Frequency		Mode	Test Position	Figure No.	Conducted Power (dBm)	Max. tune-up Power (dBm)	Measured SAR(10g) (W/kg)	Reported SAR(10g) (W/kg)	Measured SAR(1g) (W/kg)	Reported SAR(1g) (W/kg)	Power Drift (dB)
Ch.	MHz										
21100	2535	1RB_Low	Front	/	22.92	24	0.205	0.26	0.407	0.52	-0.09
21100	2535	1RB_Low	Rear	Fig.41	22.92	24	0.240	0.31	0.484	0.62	-0.07
20850	2510	50RB_Mid	Front	/	22.00	23	0.181	0.23	0.397	0.50	-0.13
20850	2510	50RB_Mid	Rear	/	22.00	23	0.199	0.25	0.437	0.55	-0.10
21350	2560	1RB_Low	Bottom	UL CA	22.59	24	0.212	0.29	0.437	0.60	0.07

Note1: The distance between the EUT and the phantom bottom is 15mm

Note2: The LTE mode is QPSK_20MHz.

Table 14.2-22: SAR Values (LTE Band38 - Head)

Ambient Temperature: 22.9 °C						Liquid Temperature: 22.5 °C						
Frequency		Mode	Side	Test Position	Figure No.	Conducted Power (dBm)	Max. tune-up Power (dBm)	Measured SAR(10g) (W/kg)	Reported SAR(10g) (W/kg)	Measured SAR(1g) (W/kg)	Reported SAR(1g) (W/kg)	Power Drift (dB)
Ch.	MHz											
38150	2610	1RB_High	Left	Touch	/	22.86	24	0.029	0.04	0.050	0.06	0.08
38150	2610	1RB_High	Left	Tilt	/	22.86	24	0.027	0.04	0.053	0.07	-0.10
38150	2610	1RB_High	Right	Touch	Fig.42	22.86	24	0.033	0.04	0.056	0.07	-0.02
38150	2610	1RB_High	Right	Tilt	/	22.86	24	0.021	0.03	0.036	0.05	0.09
38000	2595	50RB_Mid	Left	Touch	/	21.97	23	0.026	0.03	0.043	0.05	0.00
38000	2595	50RB_Mid	Left	Tilt	/	21.97	23	0.024	0.03	0.045	0.06	-0.03
38000	2595	50RB_Mid	Right	Touch	/	21.97	23	0.028	0.04	0.047	0.06	0.07
38000	2595	50RB_Mid	Right	Tilt	/	21.97	23	0.030	0.04	0.032	0.04	-0.03
38150	2610	1RB_High	Right	Touch	UL CA	22.61	24	0.017	0.02	0.029	0.04	0.09

Note1: The LTE mode is QPSK_20MHz.

Table 14.2-23: SAR Values (LTE Band38 - Body)

Frequency		Mode	Test Position	Figure No.	Conducted Power (dBm)	Max. tune-up Power (dBm)	Measured SAR(10g) (W/kg)	Reported SAR(10g) (W/kg)	Measured SAR(1g) (W/kg)	Reported SAR(1g) (W/kg)	Power Drift (dB)
Ch.	MHz										
Ambient Temperature: 22.9 °C					Liquid Temperature: 22.5 °C						
38150	2610	1RB_High	Front	/	21.95	23	0.167	0.21	0.309	0.39	0.04
38150	2610	1RB_High	Rear	/	21.95	23	0.132	0.17	0.271	0.35	-0.03
38150	2610	1RB_High	Left	/	21.95	23	0.040	0.05	0.076	0.10	0.01
38150	2610	1RB_High	Right	/	21.95	23	0.024	0.03	0.045	0.06	-0.12
38150	2610	1RB_High	Bottom	Fig.43	21.95	23	0.215	0.27	0.484	0.62	0.05
38000	2595	50RB_Mid	Front	/	21.99	23	0.117	0.15	0.248	0.31	-0.04
38000	2595	50RB_Mid	Rear	/	21.99	23	0.117	0.15	0.227	0.29	-0.06
38000	2595	50RB_Mid	Left	/	21.99	23	0.032	0.04	0.059	0.07	-0.07
38000	2595	50RB_Mid	Right	/	21.99	23	0.051	0.06	0.100	0.13	-0.05
38000	2595	50RB_Mid	Top	/	21.99	23	0.187	0.24	0.425	0.54	0.06
38150	2610	1RB_High	Bottom	UL CA	21.73	23	0.134	0.18	0.286	0.38	0.17

Note1: The distance between the EUT and the phantom bottom is 10mm.

Note2: The LTE mode is QPSK_20MHz.

Table 14.2-24: SAR Values (LTE Band38 - Body)

Frequency		Mode	Test Position	Figure No.	Conducted Power (dBm)	Max. tune-up Power (dBm)	Measured SAR(10g) (W/kg)	Reported SAR(10g) (W/kg)	Measured SAR(1g) (W/kg)	Reported SAR(1g) (W/kg)	Power Drift (dB)
Ch.	MHz										
Ambient Temperature: 22.9 °C					Liquid Temperature: 22.5 °C						
38150	2610	1RB_High	Front	Fig.44	22.86	24	0.115	0.15	0.233	0.30	-0.07
38150	2610	1RB_High	Rear	/	22.86	24	0.091	0.12	0.205	0.27	-0.11
38000	2595	50RB_Mid	Front	/	21.97	23	0.080	0.10	0.187	0.24	-0.13
38000	2595	50RB_Mid	Rear	/	21.97	23	0.080	0.10	0.172	0.22	0.03
38150	2610	1RB_High	Front	UL CA	22.61	24	0.096	0.13	0.192	0.26	0.07

Note1: The distance between the EUT and the phantom bottom is 15mm.

Note2: The LTE mode is QPSK_20MHz.

14.3 SAR results for Standard procedure

There is zoom scan measurement to be added for the highest measured SAR in each exposure configuration/band.

Table 14.3-1: SAR Values (GSM 850 MHz Band - Head)

Ambient Temperature: 22.9 °C						Liquid Temperature: 22.5 °C					
Frequency		Side	Test Position	Figure No.	Conducted Power (dBm)	Max. tune-up Power (dBm)	Measured SAR(10g) (W/kg)	Reported SAR(10g) (W/kg)	Measured SAR(1g) (W/kg)	Reported SAR(1g) (W/kg)	Power Drift (dB)
Ch.	MHz										
251	848.8	Right	Tilt	Fig.1	28.87	30.50	0.259	0.38	0.566	0.82	0.07

Table 14.3-2: SAR Values (GSM 850 MHz Band - Body)

Ambient Temperature: 22.9 °C						Liquid Temperature: 22.5 °C					
Frequency		Mode (number of timeslots)	Test Position	Figure No.	Conducted Power (dBm)	Max. tune-up Power (dBm)	Measured SAR(10g) (W/kg)	Reported SAR(10g) (W/kg)	Measured SAR(1g) (W/kg)	Reported SAR(1g) (W/kg)	Power Drift (dB)
Ch.	MHz										
128	824.2	GPRS (1)	Rear	Fig.2	32.30	33.50	0.042	0.06	0.071	0.09	0.02

Note: The distance between the EUT and the phantom bottom is 10mm.

Table 14.3-3: SAR Values (GSM 1900 MHz Band - Head)

Ambient Temperature: 22.9 °C						Liquid Temperature: 22.5 °C					
Frequency		Side	Test Position	Figure No.	Conducted Power (dBm)	Max. tune-up Power (dBm)	Measured SAR(10g) (W/kg)	Reported SAR(10g) (W/kg)	Measured SAR(1g) (W/kg)	Reported SAR(1g) (W/kg)	Power Drift (dB)
Ch.	MHz										
512	1850.2	Right	Touch	Fig.3	29.43	30.50	0.286	0.37	0.55	0.70	-0.11

Table 14.3-4: SAR Values (GSM 1900 MHz Band - Body)

Ambient Temperature: 22.9 °C						Liquid Temperature: 22.5 °C					
Frequency		Mode (number of timeslots)	Test Position	Figure No.	Conducted Power (dBm)	Max. tune-up Power (dBm)	Measured SAR(10g) (W/kg)	Reported SAR(10g) (W/kg)	Measured SAR(1g) (W/kg)	Reported SAR(1g) (W/kg)	Power Drift (dB)
Ch.	MHz										
512	1850.2	GPRS (2)	Left	Fig.4	26.26	27.50	0.147	0.20	0.294	0.39	0.13

Note1: The distance between the EUT and the phantom bottom is 10mm

Table 14.3-5: SAR Values (WCDMA 1900 MHz Band - Head)

Ambient Temperature: 22.9 °C						Liquid Temperature: 22.5 °C					
Frequency		Side	Test Position	Figure No.	Conducted Power (dBm)	Max. tune-up Power (dBm)	Measured SAR(10g) (W/kg)	Reported SAR(10g) (W/kg)	Measured SAR(1g) (W/kg)	Reported SAR(1g) (W/kg)	Power Drift (dB)
Ch.	MHz										
9662	1852.4	Right	Touch	Fig.5	18.83	20.50	0.269	0.40	0.492	0.72	0.00

Table 14.3-6: SAR Values (WCDMA 1900 MHz Band - Body)

Frequency		Test Position	Figure No.	Conducted Power (dBm)	Max. tune-up Power (dBm)	Measured SAR(10g) (W/kg)	Reported SAR(10g) (W/kg)	Measured SAR(1g) (W/kg)	Reported SAR(1g) (W/kg)	Power Drift (dB)
Ch.	MHz									
		Ambient Temperature: 22.9 °C				Liquid Temperature: 22.5 °C				
9800	1880	Left	Fig.6	23.78	25.00	0.269	0.36	0.593	0.79	-0.04

Note1: The distance between the EUT and the phantom bottom is 10mm

Table 14.3-7: SAR Values (WCDMA 1700 MHz Band - Head)

Frequency		Side	Test Position	Figure No.	Conducted Power (dBm)	Max. tune-up Power (dBm)	Measured SAR(10g) (W/kg)	Reported SAR(10g) (W/kg)	Measured SAR(1g) (W/kg)	Reported SAR(1g) (W/kg)	Power Drift (dB)
Ch.	MHz										
		Ambient Temperature: 22.9 °C				Liquid Temperature: 22.5 °C					
1513	1752.6	Right	Touch	Fig.7	19.37	21.00	0.326	0.47	0.609	0.89	-0.04

Table 14.3-8: SAR Values (WCDMA 1700 MHz Band - Body)

Frequency		Test Position	Figure No.	Conducted Power (dBm)	Max. tune-up Power (dBm)	Measured SAR(10g) (W/kg)	Reported SAR(10g) (W/kg)	Measured SAR(1g) (W/kg)	Reported SAR(1g) (W/kg)	Power Drift (dB)
Ch.	MHz									
		Ambient Temperature: 22.9 °C				Liquid Temperature: 22.5 °C				
1312	1712.4	Left	Fig.8	23.64	25.00	0.155	0.21	0.29	0.40	0.12

Note1: The distance between the EUT and the phantom bottom is 10mm

Table 14.3-9: SAR Values (WCDMA 850 MHz Band - Head)

Frequency		Side	Test Position	Figure No.	Conducted Power (dBm)	Max. tune-up Power (dBm)	Measured SAR(10g) (W/kg)	Reported SAR(10g) (W/kg)	Measured SAR(1g) (W/kg)	Reported SAR(1g) (W/kg)	Power Drift (dB)
Ch.	MHz										
		Ambient Temperature: 22.9 °C				Liquid Temperature: 22.5 °C					
4132	826.4	Right	Tilt	Fig.9	18.49	20.00	0.259	0.37	0.568	0.80	0.09

Table 14.3-10: SAR Values (WCDMA 850 MHz Band - Body)

Frequency		Test Position	Figure No.	Conducted Power (dBm)	Max. tune-up Power (dBm)	Measured SAR(10g) (W/kg)	Reported SAR(10g) (W/kg)	Measured SAR(1g) (W/kg)	Reported SAR(1g) (W/kg)	Power Drift (dB)
Ch.	MHz									
		Ambient Temperature: 22.9 °C				Liquid Temperature: 22.5 °C				
4182	836.4	Front	Fig.10	23.95	25.00	0.116	0.15	0.213	0.27	-0.13

Note: The distance between the EUT and the phantom bottom is 10mm.

Table 14.3-11: SAR Values (LTE Band2 - Head)

Ambient Temperature: 22.9 °C						Liquid Temperature: 22.5 °C						
Frequency		Mode	Side	Test Position	Figure No.	Conducted Power (dBm)	Max. tune-up Power (dBm)	Measured SAR(10g) (W/kg)	Reported SAR(10g) (W/kg)	Measured SAR(1g) (W/kg)	Reported SAR(1g) (W/kg)	Power Drift (dB)
Ch.	MHz											
19100	1900	1RB_High	Right	Touch	Fig.11	19.20	20.50	0.284	0.38	0.554	0.75	-0.09

Note1: The LTE mode is QPSK_20MHz.

Table 14.3-12: SAR Values (LTE Band2 - Body)

Ambient Temperature: 22.9 °C						Liquid Temperature: 22.5 °C					
Frequency		Mode	Test Position	Figure No.	Conducted Power (dBm)	Max. tune-up Power (dBm)	Measured SAR(10g) (W/kg)	Reported SAR(10g) (W/kg)	Measured SAR(1g) (W/kg)	Reported SAR(1g) (W/kg)	Power Drift (dB)
Ch.	MHz										
18700	1860	50RB_Mid	Left	Fig.12	21.83	23.00	0.189	0.25	0.407	0.53	-0.01

Note1: The distance between the EUT and the phantom bottom is 10mm

Note2: The LTE mode is QPSK_20MHz.

Table 14.3-13: SAR Values (LTE Band4 - Head)

Ambient Temperature: 22.9 °C						Liquid Temperature: 22.5 °C						
Frequency		Mode	Side	Test Position	Figure No.	Conducted Power (dBm)	Max. tune-up Power (dBm)	Measured SAR(10g) (W/kg)	Reported SAR(10g) (W/kg)	Measured SAR(1g) (W/kg)	Reported SAR(1g) (W/kg)	Power Drift (dB)
Ch.	MHz											
20300	1745	1RB_High	Right	Touch	Fig.13	19.17	20.50	0.258	0.35	0.494	0.67	-0.07

Note1: The LTE mode is QPSK_20MHz.

Table 14.3-14: SAR Values (LTE Band2 - Body)

Ambient Temperature: 22.9 °C						Liquid Temperature: 22.5 °C					
Frequency		Mode	Test Position	Figure No.	Conducted Power (dBm)	Max. tune-up Power (dBm)	Measured SAR(10g) (W/kg)	Reported SAR(10g) (W/kg)	Measured SAR(1g) (W/kg)	Reported SAR(1g) (W/kg)	Power Drift (dB)
Ch.	MHz										
20300	1745	1RB_High	Left	Fig.14	23.06	24.00	0.098	0.12	0.181	0.22	-0.12

Note1: The distance between the EUT and the phantom bottom is 10mm

Note2: The LTE mode is QPSK_20MHz.

Table 14.3-15: SAR Values (LTE Band5 - Head)

Ambient Temperature: 22.9 °C						Liquid Temperature: 22.5 °C						
Frequency		Mode	Side	Test Position	Figure No.	Conducted Power (dBm)	Max. tune-up Power	Measured SAR(10g) (W/kg)	Reported SAR(10g) (W/kg)	Measured SAR(1g) (W/kg)	Reported SAR(1g) (W/kg)	Power Drift (dB)
Ch.	MHz											

							(dBm)					
20450	829	1RB_High	Right	Tilt	Fig.15	18.11	20.00	0.239	0.37	0.514	0.79	0.04

Note1: The LTE mode is QPSK_10MHz.

Table 14.3-16: SAR Values (LTE Band5 - Body)

Ambient Temperature: 22.9 °C						Liquid Temperature: 22.5 °C					
Frequency		Mode	Test Position	Figure No.	Conducted Power (dBm)	Max. tune-up Power (dBm)	Measured SAR(10g) (W/kg)	Reported SAR(10g) (W/kg)	Measured SAR(1g) (W/kg)	Reported SAR(1g) (W/kg)	Power Drift (dB)
Ch.	MHz										
20450	829	1RB_High	Left	Fig.16	22.63	24.00	0.074	0.10	0.180	0.25	-0.01

Note1: The distance between the EUT and the phantom bottom is 10mm.

Note2: The LTE mode is QPSK_10MHz.

Table 14.3-17: SAR Values (LTE Band7 - Head)

Ambient Temperature: 22.9 °C						Liquid Temperature: 22.5 °C						
Frequency		Mode	Side	Test Position	Figure No.	Conducted Power (dBm)	Max. tune-up Power (dBm)	Measured SAR(10g) (W/kg)	Reported SAR(10g) (W/kg)	Measured SAR(1g) (W/kg)	Reported SAR(1g) (W/kg)	Power Drift (dB)
Ch.	MHz											
21100	2535	1RB_Low	Right	Touch	Fig.17	17.81	19.50	0.255	0.38	0.621	0.92	0.16

Note1: The LTE mode is QPSK_20MHz.

Table 14.3-18: SAR Values (LTE Band7 - Body)

Ambient Temperature: 22.9 °C						Liquid Temperature: 22.5 °C					
Frequency		Mode	Test Position	Figure No.	Conducted Power (dBm)	Max. tune-up Power (dBm)	Measured SAR(10g) (W/kg)	Reported SAR(10g) (W/kg)	Measured SAR(1g) (W/kg)	Reported SAR(1g) (W/kg)	Power Drift (dB)
Ch.	MHz										
21100	2535	1RB_Low	Left	Fig.18	21.41	22.00	0.313	0.36	0.695	0.80	0.09

Note1: The distance between the EUT and the phantom bottom is 10mm

Note2: The LTE mode is QPSK_20MHz.

Table 14.3-19: SAR Values (LTE Band38 - Head)

Ambient Temperature: 22.9 °C						Liquid Temperature: 22.5 °C						
Frequency		Mode	Side	Test Position	Figure No.	Conducted Power (dBm)	Max. tune-up Power (dBm)	Measured SAR(10g) (W/kg)	Reported SAR(10g) (W/kg)	Measured SAR(1g) (W/kg)	Reported SAR(1g) (W/kg)	Power Drift (dB)
Ch.	MHz											

38150	2610	1RB_High	Right	Touch	Fig.19	17.77	19.50	0.245	0.36	0.663	0.99	0.03
-------	------	----------	-------	-------	--------	-------	-------	-------	-------------	-------	-------------	------

Note1: The LTE mode is QPSK_20MHz.

Table 14.3-20: SAR Values (LTE Band38 - Body)

Ambient Temperature: 22.9 °C						Liquid Temperature: 22.5 °C					
Frequency		Mode	Test Position	Figure No.	Conducted Power (dBm)	Max. tune-up Power (dBm)	Measured SAR(10g) (W/kg)	Reported SAR(10g) (W/kg)	Measured SAR(1g) (W/kg)	Reported SAR(1g) (W/kg)	Power Drift (dB)
Ch.	MHz										
38150	2610	1RB_High	Left	Fig.20	22.86	24.00	0.170	0.22	0.398	0.52	0.02

Note1: The distance between the EUT and the phantom bottom is 10mm.

Note2: The LTE mode is QPSK_20MHz.

Table 14.3-21: SAR Values (GSM 1900 MHz Band - Head)

Ambient Temperature: 22.9 °C						Liquid Temperature: 22.5 °C					
Frequency		Side	Test Position	Figure No.	Conducted Power (dBm)	Max. tune-up Power (dBm)	Measured SAR(10g) (W/kg)	Reported SAR(10g) (W/kg)	Measured SAR(1g) (W/kg)	Reported SAR(1g) (W/kg)	Power Drift (dB)
Ch.	MHz										
512	1850.2	Right	Touch	Fig.21	29.43	30.5	0.049	0.06	0.083	0.11	0.07

Table 14.3-22: SAR Values (GSM 1900 MHz Band - Body)

Ambient Temperature: 22.9 °C						Liquid Temperature: 22.5 °C					
Frequency		Mode (number of timeslots)	Test Position	Figure No.	Conducted Power (dBm)	Max. tune-up Power (dBm)	Measured SAR(10g) (W/kg)	Reported SAR(10g) (W/kg)	Measured SAR(1g) (W/kg)	Reported SAR(1g) (W/kg)	Power Drift (dB)
Ch.	MHz										
512	1850.2	GPRS (1)	Bottom	Fig.22	27.27	28	0.366	0.43	0.747	0.88	-0.03

Note1: The distance between the EUT and the phantom bottom is 10mm

Table 14.3-23: SAR Values (WCDMA 1900 MHz Band - Head)

Ambient Temperature: 22.9 °C						Liquid Temperature: 22.5 °C					
Frequency		Side	Test Position	Figure No.	Conducted Power (dBm)	Max. tune-up Power (dBm)	Measured SAR(10g) (W/kg)	Reported SAR(10g) (W/kg)	Measured SAR(1g) (W/kg)	Reported SAR(1g) (W/kg)	Power Drift (dB)
Ch.	MHz										
9662	1852.4	Right	Touch	Fig.23	23.72	25	0.106	0.14	0.168	0.23	0.07

Table 14.3-24: SAR Values (WCDMA 1900 MHz Band - Body)

Ambient Temperature: 22.9 °C						Liquid Temperature: 22.5 °C					
Frequency		Test Position	Figure No.	Conducted Power (dBm)	Max. tune-up Power (dBm)	Measured SAR(10g) (W/kg)	Reported SAR(10g) (W/kg)	Measured SAR(1g) (W/kg)	Reported SAR(1g) (W/kg)	Power Drift (dB)	
Ch.	MHz										
9662	1852.4	Bottom	Fig.24	16.83	18	0.356	0.47	0.713	0.93	0.08	

Note1: The distance between the EUT and the phantom bottom is 10mm

Table 14.3-25: SAR Values (WCDMA 1900 MHz Band - Body)

Frequency		Test Position	Figure No.	Conducted Power (dBm)	Max. tune-up Power (dBm)	Ambient Temperature: 22.9 °C		Liquid Temperature: 22.5 °C		Power Drift (dB)
Ch.	MHz					Measured SAR(10g) (W/kg)	Reported SAR(10g) (W/kg)	Measured SAR(1g) (W/kg)	Reported SAR(1g) (W/kg)	
9662	1852.4	Front	Fig.25	23.72	25	0.421	0.57	0.757	1.02	-0.02

Note1: The distance between the EUT and the phantom bottom is 15mm

Table 14.3-26: SAR Values (WCDMA 1700 MHz Band - Head)

Frequency		Side	Test Position	Figure No.	Conducted Power (dBm)	Max. tune-up Power (dBm)	Ambient Temperature: 22.9 °C		Liquid Temperature: 22.5 °C		Power Drift (dB)
Ch.	MHz						Measured SAR(10g) (W/kg)	Reported SAR(10g) (W/kg)	Measured SAR(1g) (W/kg)	Reported SAR(1g) (W/kg)	
1412	1732.4	Right	Touch	Fig.26	23.84	25	0.095	0.12	0.152	0.20	-0.08

Table 14.3-27: SAR Values (WCDMA 1700 MHz Band - Body)

Frequency		Test Position	Figure No.	Conducted Power (dBm)	Max. tune-up Power (dBm)	Ambient Temperature: 22.9 °C		Liquid Temperature: 22.5 °C		Power Drift (dB)
Ch.	MHz					Measured SAR(10g) (W/kg)	Reported SAR(10g) (W/kg)	Measured SAR(1g) (W/kg)	Reported SAR(1g) (W/kg)	
1513	1752.6	Bottom	Fig.27	17.36	18.5	0.377	0.49	0.745	0.97	-0.02

Note1: The distance between the EUT and the phantom bottom is 10mm

Table 14.3-28: SAR Values (WCDMA 1700 MHz Band - Body)

Frequency		Test Position	Figure No.	Conducted Power (dBm)	Max. tune-up Power (dBm)	Ambient Temperature: 22.9 °C		Liquid Temperature: 22.5 °C		Power Drift (dB)
Ch.	MHz					Measured SAR(10g) (W/kg)	Reported SAR(10g) (W/kg)	Measured SAR(1g) (W/kg)	Reported SAR(1g) (W/kg)	
1513	1752.6	Front	Fig.28	23.86	25	0.419	0.54	0.739	0.96	-0.03

Note1: The distance between the EUT and the phantom bottom is 15mm

Table 14.3-29: SAR Values (WCDMA 850 MHz Band - Head)

Frequency		Side	Test Position	Figure No.	Conducted Power (dBm)	Max. tune-up Power (dBm)	Ambient Temperature: 22.9 °C		Liquid Temperature: 22.5 °C		Power Drift (dB)
Ch.	MHz						Measured SAR(10g) (W/kg)	Reported SAR(10g) (W/kg)	Measured SAR(1g) (W/kg)	Reported SAR(1g) (W/kg)	
4233	846.6	Left	Touch	Fig.29	23.94	25	0.143	0.18	0.187	0.24	0.04

Table 14.3-30: SAR Values (WCDMA 850 MHz Band - Body)

Ambient Temperature: 22.9 °C						Liquid Temperature: 22.5 °C				
Frequency		Test Position	Figure No.	Conducted Power (dBm)	Max. tune-up Power (dBm)	Measured SAR(10g) (W/kg)	Reported SAR(10g) (W/kg)	Measured SAR(1g) (W/kg)	Reported SAR(1g) (W/kg)	Power Drift (dB)
Ch.	MHz									
4182	836.4	Rear	Fig.30	23.95	25	0.146	0.19	0.286	0.36	0.00

Note: The distance between the EUT and the phantom bottom is 10mm.

Table 14.3-31: SAR Values (LTE Band2 - Head)

Ambient Temperature: 22.9 °C						Liquid Temperature: 22.5 °C						
Frequency		Mode	Side	Test Position	Figure No.	Conducted Power (dBm)	Max. tune-up Power (dBm)	Measured SAR(10g) (W/kg)	Reported SAR(10g) (W/kg)	Measured SAR(1g) (W/kg)	Reported SAR(1g) (W/kg)	Power Drift (dB)
Ch.	MHz											
19100	1900	1RB_High	Right	Touch	Fig.31	22.69	24	0.063	0.09	0.102	0.14	0.09

Note1: The LTE mode is QPSK_20MHz.

Table 14.3-32: SAR Values (LTE Band2 - Body)

Ambient Temperature: 22.9 °C						Liquid Temperature: 22.5 °C					
Frequency		Mode	Test Position	Figure No.	Conducted Power (dBm)	Max. tune-up Power (dBm)	Measured SAR(10g) (W/kg)	Reported SAR(10g) (W/kg)	Measured SAR(1g) (W/kg)	Reported SAR(1g) (W/kg)	Power Drift (dB)
Ch.	MHz										
19100	1900	1RB_High	Bottom	Fig.32	16.77	18	0.350	0.46	0.697	0.93	-0.13

Note1: The distance between the EUT and the phantom bottom is 10mm

Note2: The LTE mode is QPSK_20MHz.

Table 14.3-33: SAR Values (LTE Band2 - Body)

Ambient Temperature: 22.9 °C						Liquid Temperature: 22.5 °C					
Frequency		Mode	Test Position	Figure No.	Conducted Power (dBm)	Max. tune-up Power (dBm)	Measured SAR(10g) (W/kg)	Reported SAR(10g) (W/kg)	Measured SAR(1g) (W/kg)	Reported SAR(1g) (W/kg)	Power Drift (dB)
Ch.	MHz										
19100	1900	1RB_High	Front	Fig.33	22.69	24	0.347	0.47	0.628	0.85	-0.09

Note1: The distance between the EUT and the phantom bottom is 15mm

Note2: The LTE mode is QPSK_20MHz.

Table 14.3-34: SAR Values (LTE Band4 - Head)

Ambient Temperature: 22.9 °C						Liquid Temperature: 22.5 °C						
Frequency		Mode	Side	Test Position	Figure No.	Conducted Power (dBm)	Max. tune-up Power	Measured SAR(10g) (W/kg)	Reported SAR(10g) (W/kg)	Measured SAR(1g) (W/kg)	Reported SAR(1g) (W/kg)	Power Drift (dB)
Ch.	MHz											

							(dBm)					
20300	1745	1RB_High	Right	Touch	Fig.34	23.06	24	0.056	0.07	0.089	0.11	-0.05

Note1: The LTE mode is QPSK_20MHz.

Table 14.3-35: SAR Values (LTE Band2 - Body)

Ambient Temperature: 22.9 °C						Liquid Temperature: 22.5°C					
Frequency		Mode	Test Position	Figure No.	Conducted Power (dBm)	Max. tune-up Power (dBm)	Measured SAR(10g) (W/kg)	Reported SAR(10g) (W/kg)	Measured SAR(1g) (W/kg)	Reported SAR(1g) (W/kg)	Power Drift (dB)
Ch.	MHz										
20300	1745	1RB_High	Bottom	Fig.35	17.33	18.5	0.354	0.46	0.697	0.91	0.02

Note1: The distance between the EUT and the phantom bottom is 10mm

Note2: The LTE mode is QPSK_20MHz.

Table 14.3-36: SAR Values (LTE Band2 - Body)

Ambient Temperature: 22.9 °C						Liquid Temperature: 22.5°C					
Frequency		Mode	Test Position	Figure No.	Conducted Power (dBm)	Max. tune-up Power (dBm)	Measured SAR(10g) (W/kg)	Reported SAR(10g) (W/kg)	Measured SAR(1g) (W/kg)	Reported SAR(1g) (W/kg)	Power Drift (dB)
Ch.	MHz										
20300	1745	1RB_High	Front	Fig.36	23.06	24	0.296	0.37	0.528	0.66	0.03

Note1: The distance between the EUT and the phantom bottom is 15mm

Note2: The LTE mode is QPSK_20MHz.

Table 14.3-37: SAR Values (LTE Band5 - Head)

Ambient Temperature: 22.9 °C						Liquid Temperature: 22.5°C						
Frequency		Mode	Side	Test Position	Figure No.	Conducted Power (dBm)	Max. tune-up Power (dBm)	Measured SAR(10g) (W/kg)	Reported SAR(10g) (W/kg)	Measured SAR(1g) (W/kg)	Reported SAR(1g) (W/kg)	Power Drift (dB)
Ch.	MHz											
20450	829	1RB_High	Left	Touch	Fig.37	22.63	24	0.138	0.19	0.180	0.25	0.09

Note1: The LTE mode is QPSK_10MHz.

Table 14.3-38: SAR Values (LTE Band5 - Body)

Ambient Temperature: 22.9 °C						Liquid Temperature: 22.5°C					
Frequency		Mode	Test Position	Figure No.	Conducted Power (dBm)	Max. tune-up Power (dBm)	Measured SAR(10g) (W/kg)	Reported SAR(10g) (W/kg)	Measured SAR(1g) (W/kg)	Reported SAR(1g) (W/kg)	Power Drift (dB)
Ch.	MHz										
20450	829	1RB_High	Front	Fig.38	22.63	24	0.182	0.25	0.302	0.41	-0.12

Note1: The distance between the EUT and the phantom bottom is 10mm.

Note2: The LTE mode is QPSK_10MHz.

Table 14.3-39: SAR Values (LTE Band7 - Head)

Ambient Temperature: 22.9 °C						Liquid Temperature: 22.5 °C						
Frequency		Mode	Side	Test Position	Figure No.	Conducted Power (dBm)	Max. tune-up Power (dBm)	Measured SAR(10g) (W/kg)	Reported SAR(10g) (W/kg)	Measured SAR(1g) (W/kg)	Reported SAR(1g) (W/kg)	Power Drift (dB)
Ch.	MHz											
21100	2535	1RB_Low	Right	Touch	Fig.99	22.92	24	0.058	0.07	0.103	0.13	0.04

Note1: The LTE mode is QPSK_20MHz.

Table 14.3-40: SAR Values (LTE Band7 - Body)

Ambient Temperature: 22.9 °C						Liquid Temperature: 22.5 °C					
Frequency		Mode	Test Position	Figure No.	Conducted Power (dBm)	Max. tune-up Power (dBm)	Measured SAR(10g) (W/kg)	Reported SAR(10g) (W/kg)	Measured SAR(1g) (W/kg)	Reported SAR(1g) (W/kg)	Power Drift (dB)
Ch.	MHz										
21100	2535	1RB_Low	Bottom	Fig.40	20.02	21	0.289	0.36	0.626	0.78	0.02

Note1: The distance between the EUT and the phantom bottom is 10mm

Note2: The LTE mode is QPSK_20MHz.

Table 14.3-41: SAR Values (LTE Band7 - Body)

Ambient Temperature: 22.9 °C						Liquid Temperature: 22.5 °C					
Frequency		Mode	Test Position	Figure No.	Conducted Power (dBm)	Max. tune-up Power (dBm)	Measured SAR(10g) (W/kg)	Reported SAR(10g) (W/kg)	Measured SAR(1g) (W/kg)	Reported SAR(1g) (W/kg)	Power Drift (dB)
Ch.	MHz										
21100	2535	1RB_Low	Rear	Fig.41	22.92	24	0.240	0.31	0.484	0.62	-0.07

Note1: The distance between the EUT and the phantom bottom is 15mm

Note2: The LTE mode is QPSK_20MHz.

Table 14.3-42: SAR Values (LTE Band38 - Head)

Ambient Temperature: 22.9 °C						Liquid Temperature: 22.5 °C						
Frequency		Mode	Side	Test Position	Figure No.	Conducted Power (dBm)	Max. tune-up Power (dBm)	Measured SAR(10g) (W/kg)	Reported SAR(10g) (W/kg)	Measured SAR(1g) (W/kg)	Reported SAR(1g) (W/kg)	Power Drift (dB)
Ch.	MHz											
38150	2610	1RB_High	Right	Touch	Fig.42	22.86	24	0.033	0.04	0.056	0.07	-0.02

Note1: The LTE mode is QPSK_20MHz.

Table 14.3-43: SAR Values (LTE Band38 - Body)

Ambient Temperature: 22.9 °C						Liquid Temperature: 22.5 °C					
------------------------------	--	--	--	--	--	-----------------------------	--	--	--	--	--

Frequency		Mode	Test Position	Figure No.	Conducted Power (dBm)	Max. tune-up Power (dBm)	Measured SAR(10g) (W/kg)	Reported SAR(10g) (W/kg)	Measured SAR(1g) (W/kg)	Reported SAR(1g) (W/kg)	Power Drift (dB)
Ch.	MHz										
38150	2610	1RB_High	Bottom	Fig.43	21.95	23	0.215	0.27	0.484	0.62	0.05

Note1: The distance between the EUT and the phantom bottom is 10mm.

Note2: The LTE mode is QPSK_20MHz.

Table 14.3-44: SAR Values (LTE Band38 - Body)

Ambient Temperature: 22.9°C						Liquid Temperature: 22.5°C					
Frequency		Mode	Test Position	Figure No.	Conducted Power (dBm)	Max. tune-up Power (dBm)	Measured SAR(10g) (W/kg)	Reported SAR(10g) (W/kg)	Measured SAR(1g) (W/kg)	Reported SAR(1g) (W/kg)	Power Drift (dB)
Ch.	MHz										
38150	2610	1RB_High	Front	Fig.44	22.86	24	0.115	0.15	0.233	0.30	-0.07

Note1: The distance between the EUT and the phantom bottom is 15mm.

Note2: The LTE mode is QPSK_20MHz.

14.4 WLAN Evaluation for 2.4G

According to the KDB248227 D01, SAR is measured for 2.4GHz 802.11b DSSS using the initial test position procedure.

Head Evaluation -Receiver on

Table 14.4-1: SAR Values (WLAN - Head)– 802.11b (Fast SAR)

Frequency		Side	Test Position	Figure No.	Conducted Power (dBm)	Max. tune-up Power (dBm)	Ambient Temperature: 22.9 °C		Liquid Temperature: 22.5 °C		Power Drift (dB)
MHz	Ch.						Measured SAR(10g) (W/kg)	Reported SAR(10g) (W/kg)	Measured SAR(1g) (W/kg)	Reported SAR(1g)(W/kg)	
2437	6	Left	Touch	/	16.79	17.5	0.099	0.12	0.213	0.25	-0.09
2437	6	Left	Tilt	/	16.79	17.5	0.160	0.19	0.367	0.43	0.04
2437	6	Right	Touch	/	16.79	17.5	0.109	0.13	0.234	0.28	-0.03
2437	6	Right	Tilt	/	16.79	17.5	0.268	0.32	0.637	0.75	-0.05
2437	6	Right	Tilt	J1	16.79	17.5	0.243	0.29	0.604	0.71	0.05
2437	6	Right	Tilt	B1	16.79	17.5	0.207	0.24	0.563	0.66	0.04
2437	6	Right	Tilt	ANT0	15.08	15.5	0.225	0.25	0.589	0.65	0.05

As shown above table, the initial test position for head is “Right Tilt”. So the head SAR of WLAN is presented as below:

Table 14.4-2: SAR Values (WLAN - Head)– 802.11b (Full SAR)

Frequency		Side	Test Position	Figure No.	Conducted Power (dBm)	Max. tune-up Power (dBm)	Ambient Temperature: 22.9 °C		Liquid Temperature: 22.5 °C		Power Drift (dB)
MHz	Ch.						Measured SAR(10g) (W/kg)	Reported SAR(10g) (W/kg)	Measured SAR(1g) (W/kg)	Reported SAR(1g)(W/kg)	
2437	6	Left	Tilt	/	16.79	17.5	0.216	0.25	0.497	0.59	0.04
2437	6	Right	Tilt	Fig.45	16.79	17.5	0.248	0.29	0.611	0.72	-0.05

Note1: When the reported SAR of the initial test position is > 0.4 W/kg, SAR is repeated for the 802.11 transmission mode configuration tested in the initial test position using subsequent highest estimated 1-g SAR conditions determined by area scans, on the highest maximum output power channel, until the reported SAR is ≤ 0.8 W/kg.

Note2: For all positions/configurations tested using the initial test position and subsequent test positions, when the reported SAR is > 0.8 W/kg, SAR is measured for these test positions/configurations on the subsequent next highest measured output power channel until the reported SAR is ≤ 1.2 W/kg or all required channels are tested.

According to the KDB248227 D01, The reported SAR must be scaled to 100% transmission duty factor to determine compliance at the maximum tune-up tolerance limit. The scaled reported SAR is presented as below.

Table 14.4-3: SAR Values (WLAN - Head) – 802.11b (Scaled Reported SAR)

Frequency		Side	Test Position	Ambient Temperature: 22.9 °C		Liquid Temperature: 22.5 °C	
MHz	Ch.			Actual duty factor	maximum duty factor	Reported SAR (1g)(W/kg)	Scaled reported SAR (1g)(W/kg)
2437	6	Right	Tilt	100%	100%	0.72	0.72

SAR is not required for OFDM because the 802.11b adjusted SAR ≤ 1.2 W/kg.

Head Evaluation – Head Simultaneous

Table 14.4-4: SAR Values (WLAN - Head)– 802.11b (Fast SAR)

Frequency		Side	Test Position	Figure No.	Ambient Temperature: 22.9 °C		Liquid Temperature: 22.5°C				Power Drift (dB)
MHz	Ch.				Conducted Power (dBm)	Max. tune-up Power (dBm)	Measured SAR(10g) (W/kg)	Reported SAR(10g) (W/kg)	Measured SAR(1g) (W/kg)	Reported SAR(1g)(W/kg)	
2437	6	Left	Touch	/	13.93	14.5	0.048	0.05	0.098	0.11	-0.09
2437	6	Left	Tilt	/	13.93	14.5	0.067	0.08	0.139	0.16	0.04
2437	6	Right	Touch	/	13.93	14.5	0.053	0.06	0.108	0.12	-0.03
2437	6	Right	Tilt	/	13.93	14.5	0.131	0.15	0.317	0.36	-0.05

As shown above table, the initial test position for head is “Right Tilt”. So the head SAR of WLAN is presented as below:

Table 14.4-5: SAR Values (WLAN - Head)– 802.11b (Full SAR)

Frequency		Side	Test Position	Figure No.	Ambient Temperature: 22.9 °C		Liquid Temperature: 22.5°C				Power Drift (dB)
MHz	Ch.				Conducted Power (dBm)	Max. tune-up Power (dBm)	Measured SAR(10g) (W/kg)	Reported SAR(10g) (W/kg)	Measured SAR(1g) (W/kg)	Reported SAR(1g)(W/kg)	
2437	6	Right	Tilt	Fig.46	13.93	14.5	0.118	0.13	0.293	0.33	-0.05

Note1: When the reported SAR of the initial test position is > 0.4 W/kg, SAR is repeated for the 802.11 transmission mode configuration tested in the initial test position using subsequent highest estimated 1-g SAR conditions determined by area scans, on the highest maximum output power channel, until the reported SAR is \leq 0.8 W/kg.

Note2: For all positions/configurations tested using the initial test position and subsequent test positions, when the reported SAR is > 0.8 W/kg, SAR is measured for these test positions/configurations on the subsequent next highest measured output power channel until the reported SAR is \leq 1.2 W/kg or all required channels are tested.

According to the KDB248227 D01, The reported SAR must be scaled to 100% transmission duty factor to determine compliance at the maximum tune-up tolerance limit. The scaled reported SAR is presented as below.

Table 14.4-6: SAR Values (WLAN - Head) – 802.11b (Scaled Reported SAR)

Frequency		Side	Test Position	Ambient Temperature: 22.9 °C		Liquid Temperature: 22.5°C		Reported SAR (1g)(W/kg)	Scaled reported SAR (1g)(W/kg)
MHz	Ch.			Actual duty factor	maximum duty factor				
2437	6	Right	Tilt	100%	100%	0.33	0.33		

SAR is not required for OFDM because the 802.11b adjusted SAR \leq 1.2 W/kg.

Body Evaluation -Normal Power

Table 14.4-7: SAR Values (WLAN - Body)– 802.11b (Fast SAR)

Frequency		Test Position	Figure No.	Ambient Temperature: 22.9 °C		Liquid Temperature: 22.5 °C				Power Drift (dB)
MHz	Ch.			Conducted Power (dBm)	Max. tune-up Power (dBm)	Measured SAR(10g) (W/kg)	Reported SAR(10g) (W/kg)	Measured SAR(1g) (W/kg)	Reported SAR(1g)(W/kg)	
2437	6	Front	/	22.28	23	0.171	0.20	0.337	0.40	-0.03
2437	6	Rear	/	22.28	23	0.202	0.24	0.377	0.44	-0.13
2437	6	Left	/	22.28	23	0.034	0.04	0.064	0.08	0.06
2437	6	Right	/	22.28	23	0.068	0.08	0.149	0.18	-0.02
2462	11	Top	/	22.20	23	0.429	0.52	0.862	1.04	0.11
2437	6	Top	/	22.28	23	0.427	0.50	0.874	1.03	-0.09
2437	6	Top	J1	22.20	23	0.394	0.47	0.834	1.00	0.05
2437	6	Top	B1	22.20	23	0.413	0.50	0.847	1.02	0.05
2437	6	Top	ANT0	20.01	20.5	0.424	0.47	0.867	0.97	0.04

As shown above table, the initial test position for body is “Top”. So the body SAR of WLAN is presented as below:

Table 14.8-8: SAR Values (WLAN - Body)– 802.11b (Full SAR)

Frequency		Test Position	Figure No.	Ambient Temperature: 22.9 °C		Liquid Temperature: 22.5 °C				Power Drift (dB)
MHz	Ch.			Conducted Power (dBm)	Max. tune-up Power (dBm)	Measured SAR(10g) (W/kg)	Reported SAR(10g) (W/kg)	Measured SAR(1g) (W/kg)	Reported SAR(1g)(W/kg)	
2437	6	Rear	/	22.28	23	0.194	0.23	0.365	0.43	-0.13
2462	11	Top	Fig.47	22.20	23	0.431	0.52	0.913	1.10	-0.03
2437	6	Top	/	22.28	23	0.406	0.48	0.858	1.01	-0.09

Note1: When the reported SAR of the initial test position is > 0.4 W/kg, SAR is repeated for the 802.11 transmission mode configuration tested in the initial test position using subsequent highest estimated 1-g SAR conditions determined by area scans, on the highest maximum output power channel, until the reported SAR is ≤ 0.8 W/kg.

Note2: For all positions/configurations tested using the initial test position and subsequent test positions, when the reported SAR is > 0.8 W/kg, SAR is measured for these test positions/configurations on the subsequent next highest measured output power channel until the reported SAR is ≤ 1.2 W/kg or all required channels are tested.

According to the KDB248227 D01, The reported SAR must be scaled to 100% transmission duty factor to determine compliance at the maximum tune-up tolerance limit. The scaled reported SAR is presented as below.

Table 14.4-9: SAR Values (WLAN - Body) – 802.11b (Scaled Reported SAR)

Frequency		Test Position	Actual duty factor	maximum duty factor	Reported SAR (1g)(W/kg)	Scaled reported SAR (1g)(W/kg)
MHz	Ch.					
		Ambient Temperature: 22.9 °C		Liquid Temperature: 22.5 °C		
2462	11	Top	100%	100%	1.10	1.10

SAR is not required for OFDM because the 802.11b adjusted SAR \leq 1.2 W/kg.

Body Evaluation - Body Simultaneous

Table 14.4-10: SAR Values (WLAN - Body)– 802.11b (Fast SAR)

Frequency		Test Position	Figure No.	Conducted Power (dBm)	Max. tune-up Power (dBm)	Measured SAR(10g) (W/kg)	Reported SAR(10g) (W/kg)	Measured SAR(1g) (W/kg)	Reported SAR(1g)(W/kg)	Power Drift (dB)
MHz	Ch.									
		Ambient Temperature: 22.9 °C		Liquid Temperature: 22.5 °C						
2437	6	Front	/	20.51	21	0.099	0.11	0.196	0.22	-0.03
2437	6	Rear	/	20.51	21	0.165	0.18	0.310	0.35	-0.13
2437	6	Left	/	20.51	21	0.020	0.02	0.037	0.04	0.06
2437	6	Right	/	20.51	21	0.040	0.04	0.087	0.10	-0.02
2462	11	Top	/	20.51	21	0.244	0.27	0.515	0.58	-0.09
2437	6	Top	/	20.51	21	0.099	0.11	0.196	0.22	-0.03

As shown above table, the initial test position for body is “Top”. So the body SAR of WLAN is presented as below:

Table 14.4-11: SAR Values (WLAN - Body)– 802.11b (Full SAR)

Frequency		Test Position	Figure No.	Conducted Power (dBm)	Max. tune-up Power (dBm)	Measured SAR(10g) (W/kg)	Reported SAR(10g) (W/kg)	Measured SAR(1g) (W/kg)	Reported SAR(1g)(W/kg)	Power Drift (dB)
MHz	Ch.									
		Ambient Temperature: 22.9 °C		Liquid Temperature: 22.5 °C						
2437	6	Rear	/	20.51	21	0.157	0.18	0.297	0.33	-0.13
2437	6	Top	Fig.48	20.51	21	0.236	0.26	0.500	0.56	-0.09

Note1: When the reported SAR of the initial test position is > 0.4 W/kg, SAR is repeated for the 802.11 transmission mode configuration tested in the initial test position using subsequent highest estimated 1-g SAR conditions determined by area scans, on the highest maximum output power channel, until the reported SAR is \leq 0.8 W/kg.

Note2: For all positions/configurations tested using the initial test position and subsequent test positions, when the reported SAR is > 0.8 W/kg, SAR is measured for these test positions/configurations on the subsequent next highest measured output power channel until the reported SAR is \leq 1.2 W/kg or all required channels are tested.

According to the KDB248227 D01, The reported SAR must be scaled to 100% transmission duty factor to determine compliance at the maximum tune-up tolerance limit. The scaled reported SAR is presented as below.

Table 14.4-12: SAR Values (WLAN - Body) – 802.11b (Scaled Reported SAR)

Frequency		Test Position	Actual duty factor	maximum duty factor	Reported SAR (1g)(W/kg)	Scaled reported SAR (1g)(W/kg)
MHz	Ch.					
		Ambient Temperature: 22.9°C		Liquid Temperature: 22.5°C		
2437	6	Top	100%	100%	0.56	0.56

SAR is not required for OFDM because the 802.11b adjusted SAR \leq 1.2 W/kg.

Body Evaluation - Body Simultaneous

Table 14.4-13: SAR Values (WLAN - Body)– 802.11b (Fast SAR)

Frequency		Test Position	Figure No.	Conducted Power (dBm)	Max. tune-up Power (dBm)	Measured SAR(10g) (W/kg)	Reported SAR(10g) (W/kg)	Measured SAR(1g) (W/kg)	Reported SAR(1g)(W/kg)	Power Drift (dB)
MHz	Ch.									
		Ambient Temperature: 22.9°C		Liquid Temperature: 22.5°C						
2437	6	Front	/	16.79	17.5	0.043	0.05	0.087	0.10	-0.03
2437	6	Rear	/	16.79	17.5	0.054	0.06	0.099	0.12	-0.13
2437	6	Left	/	16.79	17.5	0.009	0.01	0.016	0.02	0.06
2437	6	Right	/	16.79	17.5	0.017	0.02	0.038	0.04	-0.02
2462	11	Top	/	16.79	17.5	0.109	0.13	0.231	0.27	-0.09
2437	6	Top	/	16.79	17.5	0.043	0.05	0.087	0.10	-0.03

As shown above table, the initial test position for body is “Top”. So the body SAR of WLAN is presented as below:

Table 14.4-14: SAR Values (WLAN - Body)– 802.11b (Full SAR)

Frequency		Test Position	Figure No.	Conducted Power (dBm)	Max. tune-up Power (dBm)	Measured SAR(10g) (W/kg)	Reported SAR(10g) (W/kg)	Measured SAR(1g) (W/kg)	Reported SAR(1g)(W/kg)	Power Drift (dB)
MHz	Ch.									
		Ambient Temperature: 22.9°C		Liquid Temperature: 22.5°C						
2437	6	Top	Fig.49	16.79	17.5	0.103	0.12	0.221	0.26	-0.09

Note1: When the reported SAR of the initial test position is > 0.4 W/kg, SAR is repeated for the 802.11 transmission mode configuration tested in the initial test position using subsequent highest estimated 1-g SAR conditions determined by area scans, on the highest maximum output power channel, until the reported SAR is \leq 0.8 W/kg.

Note2: For all positions/configurations tested using the initial test position and subsequent test positions, when the reported SAR is > 0.8 W/kg, SAR is measured for these test positions/configurations on the subsequent next highest measured output power channel until the reported SAR is \leq 1.2 W/kg or all required channels are tested.

According to the KDB248227 D01, The reported SAR must be scaled to 100% transmission duty factor to determine compliance at the maximum tune-up tolerance limit. The scaled reported SAR is presented as below.

Table 14.4-15: SAR Values (WLAN - Body) – 802.11b (Scaled Reported SAR)

Frequency		Test Position	Actual duty factor	maximum duty factor	Reported SAR (1g)(W/kg)	Scaled reported SAR (1g)(W/kg)
MHz	Ch.					
2437	6	Top	100%	100%	0.26	0.26

SAR is not required for OFDM because the 802.11b adjusted SAR ≤ 1.2 W/kg.

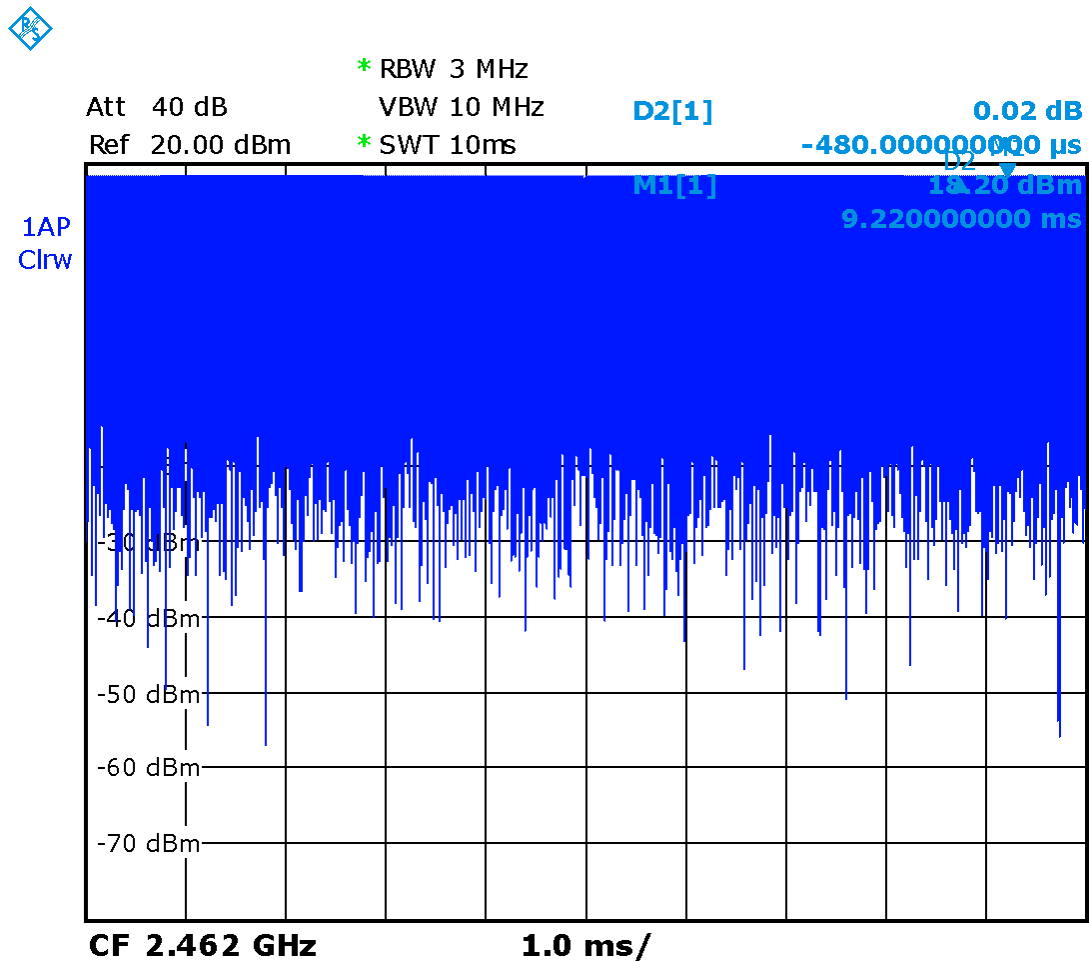

Picture 14.1 Duty factor plot for Head

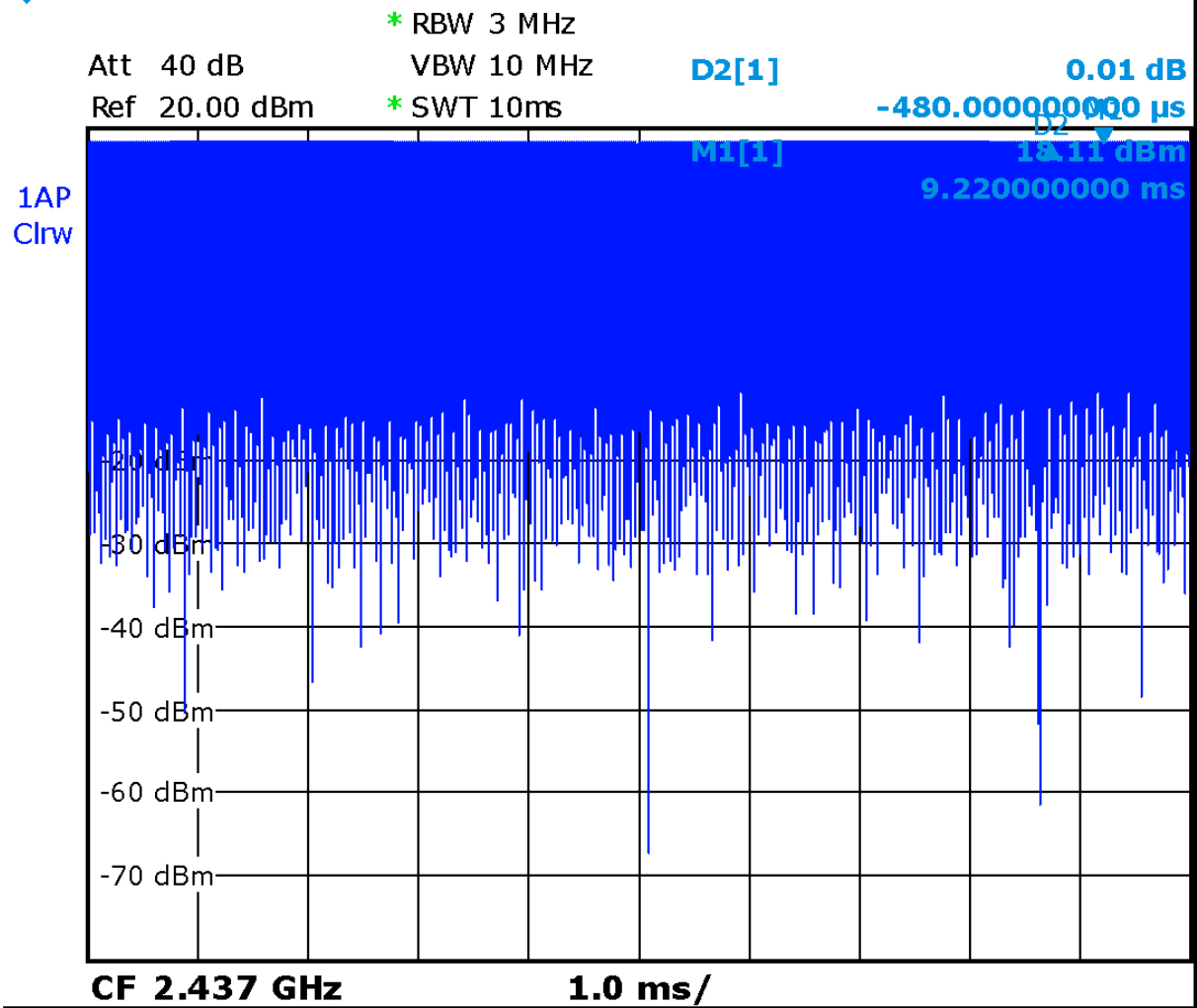

Picture 14.1 Duty factor plot for Body

14.5 WLAN Evaluation For 5G

Table 14.4-1: OFDM mode specified maximum output power of WLAN antenna

802.11 mode	a	g	n		ac				ax	
Ch. BW(MHz)	20	20	20	40	20	40	80	160	20	40
U-NII-1	X		X	X	X	X	X		X	X
U-NII-2A	X		X	X	X	X	X		X	X
U-NII-2C	X		X	X	X	X	X		X	X
U-NII-3	X		X	X	X	X	X		X	X
§ 15.247 (5.8/ GHz)										

X: maximum(conducted) output power(mW), including tolerance, specified for production units

Table 14.4-2: Maximum output power specified of WLAN antenna-Head Receiver on

802.11 mode	a	g	n		ac				ax	
Ch. BW(MHz)	20	20	20	40	20	40	80	160	20	40
U-NII-1	50		45	45	45	45	45		45	45
U-NII-2A	50		45	45	45	45	45		45	45
U-NII-2C	45		40	40	40	40	40		40	40
U-NII-3	71		63	63	63	63	63		63	63
§ 15.247 (5.8 GHz)										

- The maximum output power specified for production units is the same for all channels, modulations and data rates in each channel bandwidth configuration of the 802.11a/g/n/ac modes.
- The blue highlighted cells represent highest output configurations in each standalone or aggregated frequency band, with tune-up tolerance included.

Table 14.4-3: Maximum output power specified of WLAN antenna-Head Simultaneous

802.11 mode	a	g	n		ac				ax	
Ch. BW(MHz)	20	20	20	40	20	40	80	160	20	40
U-NII-1	18		16	16	16	16	16		16	16
U-NII-2A	18		16	16	16	16	16		16	16
U-NII-2C	16		14	14	14	14	14		14	14
U-NII-3	22		20	20	20	20	20		20	20
§ 15.247 (5.8 GHz)										

- The maximum output power specified for production units is the same for all channels, modulations and data rates in each channel bandwidth configuration of the 802.11a/g/n/ac modes.
- The blue highlighted cells represent highest output configurations in each standalone or aggregated frequency band, with tune-up tolerance included.

Table 14.4-4: Maximum output power specified of WLAN antenna-Body Normal Power

802.11 mode	a	g	n		ac				ax	
Ch. BW(MHz)	20	20	20	40	20	40	80	160	20	40
U-NII-1	89		79	79	79	79	79		79	79
U-NII-2A	100		89	89	89	89	89		89	89
U-NII-2C	89		79	79	79	79	79		79	79
U-NII-3	141		126	126	126	126	126		126	126
§ 15.247 (5.8 GHz)										
<ul style="list-style-type: none"> The maximum output power specified for production units is the same for all channels, modulations and data rates in each channel bandwidth configuration of the 802.11a/g/n/ac modes. The blue highlighted cells represent highest output configurations in each standalone or aggregated frequency band, with tune-up tolerance included. 										

Table 14.4-5: Maximum output power measured of WLAN antenna, for the applicable OFDM configurations according to the default power measurement procedures for selection initial test configurations - Head Receiver on

802.11 mode	a	n		ac			ax	
BW(MHz)	20	20	40	20	40	80	20	40
U-NII-1	36/40/44/48 40/40/41/42	36/40 /44/4 8 Lower power	38/46 Lower power	36/40/ 44/48 Lower power	38/46 Lower power	42 Lower power	36/40/44/ 48 Lower power	36/40/44/4 8 Lower power
U-NII-2A	52/56/60/64 42/40/40/39	52/56 /60/6 4 Lower power	54/62 Lower power	52/56/ 60/64 Lower power	54/62 Lower power	58 Lower power	52/56/60/ 64 Lower power	52/56/60/6 4 Lower power
U-NII-2C	100/104/108/112/116 /120/124/128/132/136/140/144 38/37/37/37/36/36/36 /36/36/36/36/36	100/1 04/10 8/112 116/1 32/13 6/140 Lower power	102/11 0/118/1 26/134/ 142 Lower power	100/1 04/10 8/112 116/1 32/13 6/140 Lower power	102/1 10/13 4 Lower power	106/1 22/13 8 Lower power	100/104/1 08/112/11 6/120/124 /128/132/ 136/140/1 44 Lower power	100/104/10 8/112/116/1 20/124/128 /132/136/1 40/144 Lower power
U-NII-3	149/153/157/161 61/61/63/60	149/1 53/15 7/161 Lower power	151/15 9 Lower power	149/1 53/15 7/161 Lower power	151/1 59 Lower power	155 Lower power	149/153/1 57/161 Lower power	149/153/15 7/161 Lower power

		power		power				
<ul style="list-style-type: none"> ● The bold numbers is the maximum output measured power (mW). ● Channels with measured maximum power within 0.25dB are considered to have the same measured output. ● Channels selected for initial test configuration are highlighted in yellow. 								

Table 14.4-6: Maximum output power measured of WLAN antenna, for the applicable OFDM configurations according to the default power measurement procedures for selection initial test configurations - Head Simultaneous

802.11 mode	a	n		ac			ax	
BW(MHz)	20	20	40	20	40	80	20	40
U-NII-1	36/40/44/ 48 14/14/14/15	36/40/ 44/48 Lower power	38/46 Lower power	36/40/ 44/48 Lower power	38/46 Lower power	42 Lower power	36/40/44/48 Lower power	36/40/44/ 48 Lower power
U-NII-2A	52 /56/60/64 15/14/14/14/	52/56/ 60/64 Lower power	54/62 Lower power	52/56/ 60/64 Lower power	54/62 Lower power	58 Lower power	52/56/60/64 Lower power	52/56/60/ 64 Lower power
U-NII-2C	100 /104/108/112/116 /120/124/128/132/13 6/140/144 14/13/13/13/13/13/13 /13/13/13/13/13	100/1 04/10 8/112 116/1 32/13 6/140 Lower power	102/11 0/118/1 26/134/ 142 Lower power	100/1 04/10 8/112 116/1 32/13 6/140 Lower power	102/1 10/13 4 Lower power	106/1 22/13 8 Lower power	100/104/10 8/112/116/1 20/124/128/ 132/136/14 0/144 Lower power	100/104/1 08/112/11 6/120/124 /128/132/ 136/140/1 44 Lower power
U-NII-3	149/153/ 157 /161 19/19/20/19	149/1 53/15 7/161 Lower power	151/15 9 Lower power	149/1 53/15 7/161 Lower power	151/1 59 Lower power	155 Lower power	149/153/15 7/161 Lower power	149/153/1 57/161 Lower power

<ul style="list-style-type: none"> ● The bold numbers is the maximum output measured power (mW). ● Channels with measured maximum power within 0.25dB are considered to have the same measured output. ● Channels selected for initial test configuration are highlighted in yellow. 								
---	--	--	--	--	--	--	--	--

Table 14.4-7: Maximum output power measured of WLAN antenna, for the applicable OFDM configurations according to the default power measurement procedures for selection initial test configurations - Body Normal Power

802.11 mode	a	n		ac			ax	
		20	20	40	20	40	80	20
U-NII-1	36/40/44/ 48 77/78/78/80	36/40 /44/4 8 Lower power	38/46 Lower power	36/40/ 44/48 Lower power	38/46 Lower power	42 Lower power	36/40/44/4 8 Lower power	36/40/44/48 Lower power
U-NII-2A	52 /56/60/64 82/78/76/76	52/56 /60/6 4 Lower power	54/62 Lower power	52/56/ 60/64 Lower power	54/62 Lower power	58 Lower power	52/56/60/6 4 Lower power	52/56/60/64 Lower power
U-NII-2C	100 /104/108/112/116 /120/124/128/132/13 6/140/144 72/71/71/70/70/69 /69/70/70/70/70	100/1 04/10 8/112 116/1 32/13 6/140 Lower power	102/11 0/118/1 26/134/ 142 Lower power	100/1 04/10 8/112 116/1 32/13 6/140 Lower power	102/1 10/13 4 Lower power	106/1 22/13 8 Lower power	100/104/1 08/112/11 6/120/124/ 128/132/1 36/140/14 4 Lower power	100/104/108 /112/116/120 /124/128/13 2/136/140/1 44 Lower power
U-NII-3	149/153/ 157 /161 119/120/126/124	149/1 53/15 7/161 Lower power	151/15 9 Lower power	149/1 53/15 7/161 Lower power	151/1 59 Lower power	155 Lower power	149/153/1 57/161 Lower power	149/153/157 /161 Lower power

- The **bold numbers** is the maximum output measured power (mW).
- Channels with measured maximum power within 0.25dB are considered to have the same measured output.
- Channels selected for initial test configuration are **highlighted in yellow**.

Table 14.4-8: Reported SAR of initial test configuration for Head Receiver on

802.11 mode	a	n		ac			ax	
BW(MHz)	20	20	40	20	40	80	20	40
U-NII-2A	52/56/60/64 0.37	52/56/60/6 4	54/62	52/56/60/ 64	54/62	58	52/56/60/6 4	52/56/60/ 64
U-NII-2C	100/104/108/112 116/120/124/128 132/136/140/144 0.86	100/104/10 8/112 116/132/13 6/140	102/110/1 18/126/1 34/142	100/104/ 108/112 116/132/ 136/140	102/110 /134	106/122 /138	100/104/10 8/112	100/104/ 108/112
U-NII-3	149/153/157/161 1.09	149/153/15 7/161	151/159	149/153/ 157/161	151/159	155	149/153/15 7/161	149/153/ 157/161

Highest measured output power channel tested initially are in yellow highlight.

Table 14.4-9: Reported SAR of initial test configuration for Head Receiver on

802.11 mode	a	n		ac			ax	
BW(MHz)	20	20	40	20	40	80	20	40
U-NII-2C	100/104/108/112 116/120/122/124/128 132/136/140/144 0.85	100/104/ 108/112 116/132/ 136/140	102/110/1 18/126/1 34/142	100/104/ 108/112 116/132/ 136/140	102/110 /134	106/122 /138	100/104/10 8/112	100/104/ 108/112
U-NII-3	149/153/157/1615 1.08	149/153/ 157/161	151/159	149/153/ 157/161	151/159	155	149/153/15 7/161	149/153/ 157/161

Highest measured output power channel tested initially are in green highlight.

Table 14.4-10: Reported SAR of initial test configuration for Head Simultaneous

802.11 mode	a	n		ac			ax	
BW(MHz)	20	20	40	20	40	80	20	40
U-NII-2A	52/56/60/64 0.10	52/56/60/64	54/62	52/56/60/6 4	54/62	58	52/56/6 0/64	52/56/60/ 64
U-NII-2C	100/104/108/112 116/120/124/128 132/136/140/144 0.24	100/104/108 /112 116/132/136 /140	102/110/11 8/126/134/ 142	100/104/10 8/112 116/132/13 6/140	102/11 0/134	106/122 /138	100/104 /108/11 2	100/104/ 108/112
U-NII-3	149/153/157/161 0.31	149/153/157 /161	151/159	149/153/15 7/161	151/1 59	155	149/153 /157/16 1	149/153/ 157/161

Highest measured output power channel tested initially are in yellow highlight.

Table 14.4-11: Reported SAR of initial test configuration for Body – Normal Power

802.11 mode	a	n		ac			ax	
BW(MHz)	20	20	40	20	40	80	20	40
U-NII-1	36/40/44/48 0.35	36/40/44/48	38/46	36/40/44/48	38/46	42	36/40/44/48	36/40/44/48
U-NII-2A	52/56/60/64 0.18	52/56/60/64	54/62	52/56/60/64	54/62	58	52/56/60/64	52/56/60/64
U-NII-2C	100/104/108/112 116/120/124/128 132/136/140/144 0.16	100/104/108 /112 116/132/136 /140	102/110/118/126/134/142	100/104/108 /112 116/132/136 /140	102/110/134	106/122/138	100/104/108/112	100/104/108/112
U-NII-3	149/153/157/161 0.33	149/153/157/161	151/159	149/153/157/161	151/159	155	149/153/157/161	149/153/157/161

Highest measured output power channel tested initially are in **yellow highlight**.

Table 14.4-12: SAR Values (WLAN 5G – Head Receiver on)

Frequency		Side	Test Position	Figure No.	Conducted Power (dBm)	Max. tune-up Power (dBm)	Measured SAR(10g) (W/kg)	Reported SAR(10g) (W/kg)	Measured SAR(1g) (W/kg)	Reported SAR(1g) (W/kg)	Power Drift (dB)
Ch.	MHz										
52	5260	Left	Touch	/	16.27	17	0.100	0.12	0.310	0.37	-0.07
52	5260	Left	Tilt	/	16.27	17	0.100	0.12	0.310	0.37	0.03
52	5260	Right	Touch	/	16.27	17	0.103	0.12	0.293	0.35	0.01
52	5260	Right	Tilt	/	16.27	17	0.103	0.12	0.295	0.35	0.00
100	5500	Left	Touch	/	15.75	16.5	0.129	0.15	0.425	0.51	-0.11
100	5500	Left	Tilt	/	15.75	16.5	0.196	0.23	0.721	0.86	-0.11
112	5560	Left	Tilt	/	15.63	16.5	0.192	0.23	0.697	0.85	0.07
100	5500	Right	Touch	/	15.75	16.5	0.123	0.15	0.407	0.48	-0.08
100	5500	Right	Tilt	/	15.75	16.5	0.126	0.15	0.419	0.50	-0.13
157	5785	Left	Touch	/	17.99	18.5	0.162	0.18	0.567	0.64	-0.03
157	5785	Left	Tilt	Fig.50	17.99	18.5	0.252	0.28	0.972	1.09	0.09
153	5765	Left	Tilt	/	17.83	18.5	0.222	0.26	0.928	1.08	0.07
157	5785	Right	Touch	/	17.99	18.5	0.155	0.17	0.417	0.47	0.01
157	5785	Right	Tilt	/	17.99	18.5	0.201	0.23	0.561	0.63	0.12
157	5785	Left	Tilt	J1	17.99	18.5	0.220	0.25	0.932	1.05	0.07
157	5785	Left	Tilt	B1	17.99	18.5	0.237	0.27	0.946	1.06	0.07
157	5785	Left	Tilt	ANT0	14.88	15.5	0.227	0.26	0.934	1.08	0.02

Table 14.4-12: SAR Values (WLAN 5G – Head Simultaneous)

Frequency		Side	Test Position	Figure No.	Conducted Power (dBm)	Max. tune-up Power (dBm)	Measured SAR(10g) (W/kg)	Reported SAR(10g) (W/kg)	Measured SAR(1g) (W/kg)	Reported SAR(1g) (W/kg)	Power Drift (dB)
Ch.	MHz										
52	5260	Left	Touch	/	11.78	12.5	0.027	0.03	0.088	0.10	0.03
52	5260	Left	Tilt	/	11.78	12.5	0.027	0.03	0.088	0.10	-0.02
52	5260	Right	Touch	/	11.78	12.5	0.028	0.03	0.083	0.10	0.08
52	5260	Right	Tilt	/	11.78	12.5	0.028	0.03	0.084	0.10	0.07
100	5500	Left	Touch	/	11.31	12	0.035	0.04	0.121	0.14	0.06
100	5500	Left	Tilt	/	11.31	12	0.053	0.06	0.206	0.24	0.06
100	5500	Right	Touch	/	11.31	12	0.033	0.04	0.116	0.14	0.11
100	5500	Right	Tilt	/	11.31	12	0.034	0.04	0.119	0.14	0.13
157	5785	Left	Touch	/	12.95	13.5	0.044	0.05	0.162	0.18	0.07
157	5785	Left	Tilt	Fig.51	12.95	13.5	0.068	0.08	0.277	0.31	-0.12
157	5785	Right	Touch	/	12.95	13.5	0.042	0.05	0.119	0.14	0.05
157	5785	Right	Tilt	/	12.95	13.5	0.054	0.06	0.160	0.18	-0.10

Table 14.4-13: SAR Values (WLAN 5G – Body Normal Power)

Frequency		Test Position	Figure No.	Conducted Power (dBm)	Max. tune-up Power (dBm)	Measured SAR(10g) (W/kg)	Reported SAR(10g) (W/kg)	Measured SAR(1g) (W/kg)	Reported SAR(1g) (W/kg)	Power Drift (dB)
Ch.	MHz									
48	5240	Front	/	19.05	19.5	0.031	0.03	0.083	0.09	0.04
48	5240	Rear	Fig.52	19.05	19.5	0.090	0.10	0.312	0.35	0.02
48	5240	Right	/	19.05	19.5	0.032	0.04	0.089	0.10	-0.08
48	5240	Top	/	19.05	19.5	0.039	0.04	0.089	0.10	0.10
48	5240	Front	Note2	19.05	19.5	0.021	0.02	0.054	0.06	0.09
48	5240	Rear	Note2	19.05	19.5	0.062	0.07	0.157	0.17	0.08
52	5260	Front	/	19.12	20	0.020	0.02	0.048	0.06	-0.09
52	5260	Rear	/	19.12	20	0.061	0.07	0.145	0.18	-0.04
52	5260	Front	Note3	19.12	20	0.455	0.56	1.680	2.06	0.10
52	5260	Rear	Note3	19.12	20	0.367	0.45	1.340	1.64	0.07
52	5260	Right	Note3	19.12	20	0.184	0.23	0.809	0.99	0.05
52	5260	Top	Note3	19.12	20	0.445	0.54	1.570	1.92	0.07
100	5500	Front	/	18.55	19.5	0.021	0.03	0.054	0.07	0.08
100	5500	Rear	/	18.55	19.5	0.051	0.06	0.128	0.16	0.04
100	5500	Front	Note3	18.55	19.5	0.510	0.63	2.080	2.59	0.06
100	5500	Rear	Note3	18.55	19.5	0.436	0.54	1.330	1.66	0.01
100	5500	Right	Note3	18.55	19.5	0.159	0.20	0.530	0.66	-0.14
100	5500	Top	Note3	18.55	19.5	0.415	0.52	1.400	1.74	0.05
157	5785	Front	/	20.99	21.5	0.056	0.06	0.149	0.17	0.00
157	5785	Rear	/	20.99	21.5	0.010	0.01	0.293	0.33	-0.04
157	5785	Right	/	20.99	21.5	0.009	0.01	0.016	0.02	0.13

157	5785	Top	/	20.99	21.5	0.026	0.03	0.063	0.07	-0.08
157	5785	Front	Note2	20.99	21.5	0.035	0.04	0.088	0.10	0.11
157	5785	Rear	Note2	20.99	21.5	0.061	0.07	0.169	0.19	0.02
48	5240	Rear	ANT0	17.34	18	0.093	0.11	0.275	0.32	0.06
48	5240	Rear	J1	19.05	19.5	0.082	0.09	0.303	0.34	0.07
48	5240	Rear	B1	19.05	19.5	0.079	0.09	0.294	0.33	0.03

Note: The distance between the EUT and the phantom bottom is 10mm.

Note2: The distance between the EUT and the phantom bottom is 15mm.

Note3: The distance between the EUT and the phantom bottom is 0mm.

According to the KDB248227 D01, The reported SAR must be scaled to 100% transmission duty factor to determine compliance at the maximum tune-up tolerance limit. The scaled reported SAR is presented as below.

Table 14.4-14: SAR Values (WLAN 5G – Head Receiver on) (Scaled Reported SAR)

Frequency		Side	Test Position	Actual duty factor	maximum duty factor	Reported SAR (1g) (W/kg)	Scaled reported SAR (1g) (W/kg)
Ch.	MHz						
157	5785	Left	Tilt	100%	100%	1.09	1.09

Table 14.4-15: SAR Values (WLAN 5G – Head Simultaneous) (Scaled Reported SAR)

Frequency		Side	Test Position	Actual duty factor	maximum duty factor	Reported SAR (1g) (W/kg)	Scaled reported SAR (1g) (W/kg)
Ch.	MHz						
157	5785	Left	Tilt	100%	100%	0.31	0.31

Table 14.4-16 SAR Values (WLAN 5G – Body Normal Power) (Scaled Reported SAR)

Frequency		Test Position	D (mm)	Actual duty factor	maximum duty factor	Reported SAR (1g) (W/kg)	Scaled reported SAR (1g) (W/kg)
Ch.	MHz						
48	5240	Rear	10	100%	100%	0.35	0.35

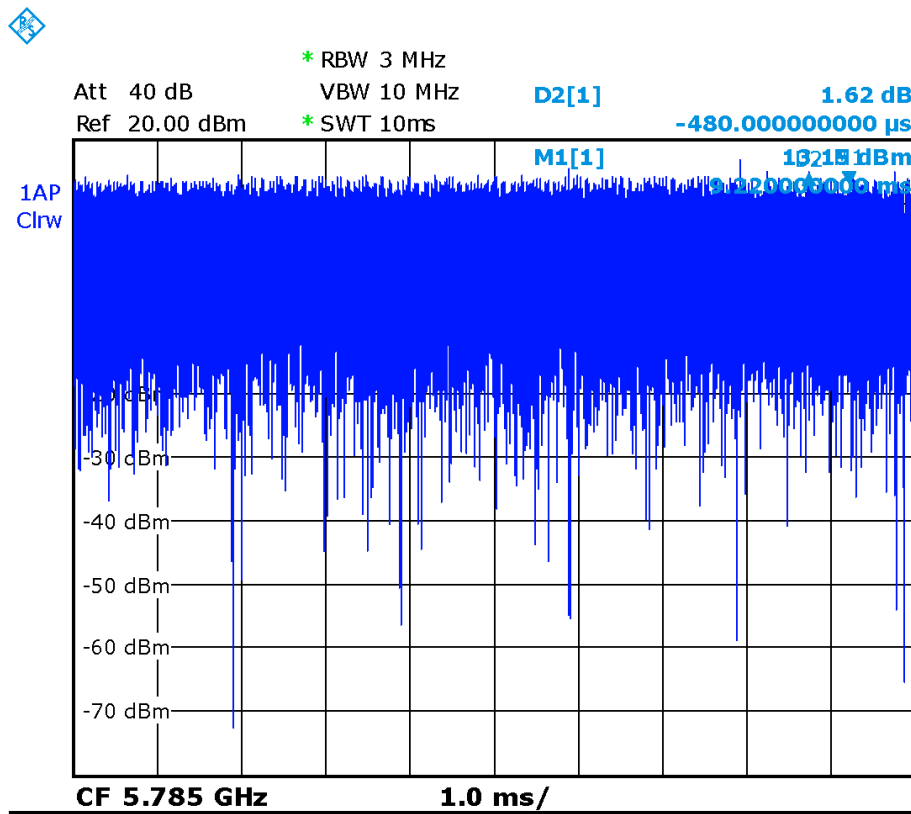

Picture 14.2 The plot of duty factor for Head

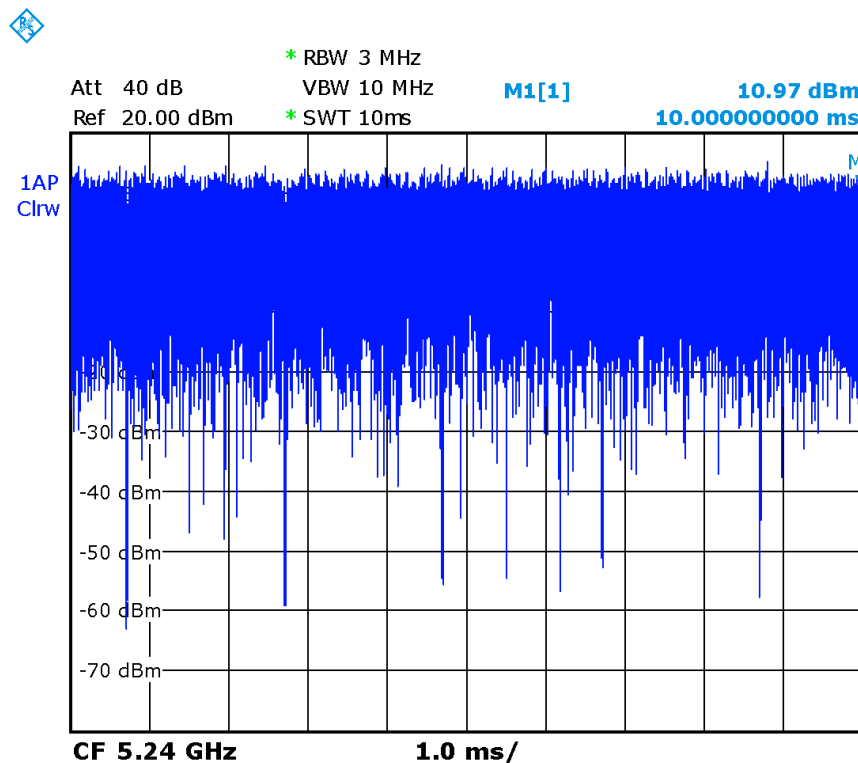

Picture 14.3 The plot of duty factor for Body

14.6 SAR results for BT

Normal Power

Table 14.6-1: SAR Values (BT – Head ANT3)

Frequency		Side	Test Position	Figure No.	Conducted Power (dBm)	Max. tune-up Power (dBm)	Measured SAR(10g) (W/kg)	Reported SAR(10g) (W/kg)	Measured SAR(1g) (W/kg)	Reported SAR(1g) (W/kg)	Power Drift (dB)
Ch.	MHz										
Ambient Temperature: 22.9°C Liquid Temperature: 22.5°C											
39	2440	Left	Touch	/	18.94	19.5	0.134	0.15	0.298	0.34	0.05
39	2440	Left	Tilt	/	18.94	19.5	0.194	0.22	0.451	0.51	0.09
39	2440	Right	Touch	/	18.94	19.5	0.176	0.20	0.388	0.44	0.17
78	2480	Right	Tilt	/	18.86	19.5	0.234	0.27	0.586	0.68	0.04
39	2440	Right	Tilt	/	18.94	19.5	0.221	0.25	0.567	0.65	-0.06
0	2402	Right	Tilt	Fig.53	18.98	19.5	0.259	0.29	0.611	0.69	0.03

Table 14.6-2: SAR Values (BT – Body ANT3)

Frequency		Test Position	Figure No.	Conducted Power (dBm)	Max. tune-up Power (dBm)	Measured SAR(10g) (W/kg)	Reported SAR(10g) (W/kg)	Measured SAR(1g) (W/kg)	Reported SAR(1g) (W/kg)	Power Drift (dB)
Ch.	MHz									
Ambient Temperature: 22.9°C Liquid Temperature: 22.5°C										
39	2440	Front	/	18.94	19.5	0.061	0.07	0.125	0.14	-0.05
39	2440	Rear	/	18.94	19.5	0.077	0.09	0.140	0.16	0.06
39	2440	Right	/	18.94	19.5	0.013	0.01	0.024	0.03	-0.08
78	2480	Top	/	18.86	19.5	0.127	0.15	0.283	0.33	0.04
39	2440	Top	/	18.94	19.5	0.111	0.13	0.261	0.30	0.07
0	2402	Top	Fig.54	18.98	19.5	0.145	0.16	0.304	0.34	0.02

Note1: The distance between the EUT and the phantom bottom is 10mm

Table 14.6-3: SAR Values (BT – Head ANT4)

Frequency		Side	Test Position	Figure No.	Conducted Power (dBm)	Max. tune-up Power (dBm)	Measured SAR(10g) (W/kg)	Reported SAR(10g) (W/kg)	Measured SAR(1g) (W/kg)	Reported SAR(1g) (W/kg)	Power Drift (dB)
Ch.	MHz										
Ambient Temperature: 22.9°C Liquid Temperature: 22.5°C											
78	2480	Left	Touch	/	18.14	18.5	<0.01	<0.01	<0.01	<0.01	0.12
39	2440	Left	Touch	/	18.09	18.5	<0.01	<0.01	<0.01	<0.01	0.03
0	2402	Left	Touch	/	18.17	18.5	<0.01	<0.01	<0.01	<0.01	0.04
39	2440	Left	Tilt	/	18.17	18.5	<0.01	<0.01	<0.01	<0.01	-0.05
39	2440	Right	Touch	/	18.17	18.5	<0.01	<0.01	<0.01	<0.01	-0.04
39	2440	Right	Tilt	/	18.17	18.5	<0.01	<0.01	<0.01	<0.01	0.00

Table 14.6-2: SAR Values (BT – Body ANT4)

Frequency		Test Position	Figure No.	Ambient Temperature: 22.9 °C		Liquid Temperature: 22.5 °C				Power Drift (dB)
Ch.	MHz			Conducted Power (dBm)	Max. tune-up Power (dBm)	Measured SAR(10g) (W/kg)	Reported SAR(10g) (W/kg)	Measured SAR(1g) (W/kg)	Reported SAR(1g) (W/kg)	
78	2480	Front	/	18.14	18.5	<0.01	<0.01	<0.01	<0.01	-0.09
39	2440	Front	/	18.09	18.5	<0.01	<0.01	<0.01	<0.01	0.06
0	2402	Front	/	18.17	18.5	<0.01	<0.01	<0.01	<0.01	-0.08
39	2440	Rear	/	18.17	18.5	<0.01	<0.01	<0.01	<0.01	0.04
39	2440	Right	/	18.17	18.5	<0.01	<0.01	<0.01	<0.01	-0.05

Note1: The distance between the EUT and the phantom bottom is 10mm

Low Power
Table 14.6-1: SAR Values (BT – Head ANT3)

Frequency		Side	Test Position	Figure No.	Ambient Temperature: 22.9 °C		Liquid Temperature: 22.5 °C				Power Drift (dB)
Ch.	MHz				Conducted Power (dBm)	Max. tune-up Power (dBm)	Measured SAR(10g) (W/kg)	Reported SAR(10g) (W/kg)	Measured SAR(1g) (W/kg)	Reported SAR(1g) (W/kg)	
39	2440	Left	Touch	/	11.05	11.5	0.034	0.04	0.079	0.09	0.03
39	2440	Left	Tilt	/	11.05	11.5	0.049	0.05	0.120	0.13	-0.03
39	2440	Right	Touch	/	11.05	11.5	0.044	0.05	0.103	0.11	0.05
78	2480	Right	Tilt	/	10.16	11.5	0.051	0.07	0.127	0.17	0.06
39	2440	Right	Tilt	Fig.55	11.05	11.5	0.065	0.07	0.162	0.18	0.10
0	2402	Right	Tilt	/	10.21	11.5	0.049	0.07	0.121	0.16	0.09

Table 14.6-2: SAR Values (BT – Body ANT3)

Frequency		Test Position	Figure No.	Ambient Temperature: 22.9 °C		Liquid Temperature: 22.5 °C				Power Drift (dB)
Ch.	MHz			Conducted Power (dBm)	Max. tune-up Power (dBm)	Measured SAR(10g) (W/kg)	Reported SAR(10g) (W/kg)	Measured SAR(1g) (W/kg)	Reported SAR(1g) (W/kg)	
39	2440	Front	/	11.05	11.5	0.012	0.01	0.025	0.03	0.07
39	2440	Rear	/	11.05	11.5	0.015	0.02	0.028	0.03	0.09
39	2440	Right	/	11.05	11.5	0.000	0.00	0.000	0.00	-0.11
78	2480	Top	/	10.16	11.5	0.021	0.03	0.046	0.06	0.02
39	2440	Top	Fig.56	11.05	11.5	0.028	0.03	0.060	0.07	-0.12
0	2402	Top	/	10.21	11.5	0.020	0.03	0.045	0.06	0.03

Note1: The distance between the EUT and the phantom bottom is 10mm

15 SAR Measurement Variability

SAR measurement variability must be assessed for each frequency band, which is determined by the SAR probe calibration point and tissue-equivalent medium used for the device measurements. When both head and body tissue-equivalent media are required for SAR measurements in a frequency band, the variability measurement procedures should be applied to the tissue medium with the highest measured SAR, using the highest measured SAR configuration for that tissue-equivalent medium.

The following procedures are applied to determine if repeated measurements are required.

- 1) Repeated measurement is not required when the original highest measured SAR is < 0.80 W/kg; steps 2) through 4) do not apply.
- 2) When the original highest measured SAR is ≥ 0.80 W/kg, repeat that measurement once.
- 3) Perform a second repeated measurement only if the ratio of largest to smallest SAR for the original and first repeated measurements is > 1.20 or when the original or repeated measurement is ≥ 1.45 W/kg ($\sim 10\%$ from the 1-g SAR limit).
- 4) Perform a third repeated measurement only if the original, first or second repeated measurement is ≥ 1.5 W/kg and the ratio of largest to smallest SAR for the original, first and second repeated measurements is > 1.20 .

Table 15.1: SAR Measurement Variability for WLAN 5G – Head Receiver on (1g)

Frequency		Side	Test Position	Original SAR (W/kg)	First Repeated SAR (W/kg)	The Ratio	Second Repeated SAR (W/kg)
Ch.	MHz						
157	5785	Left	Tilt	1.09	0.994	1.10	/

16 Measurement Uncertainty

16.1 Measurement Uncertainty for Normal SAR Tests (300MHz~3GHz)

No.	Error Description	Type	Uncertainty value	Probably Distribution	Div.	(Ci) 1g	(Ci) 10g	Std. Unc. (1g)	Std. Unc. (10g)	Degree of freedom
Measurement system										
1	Probe calibration	B	6.0	N	1	1	1	6.0	6.0	∞
2	Isotropy	B	4.7	R	$\sqrt{3}$	0.7	0.7	1.9	1.9	∞
3	Boundary effect	B	1.0	R	$\sqrt{3}$	1	1	0.6	0.6	∞
4	Linearity	B	4.7	R	$\sqrt{3}$	1	1	2.7	2.7	∞
5	Detection limit	B	1.0	N	1	1	1	0.6	0.6	∞
6	Readout electronics	B	0.3	R	$\sqrt{3}$	1	1	0.3	0.3	∞
7	Response time	B	0.8	R	$\sqrt{3}$	1	1	0.5	0.5	∞
8	Integration time	B	2.6	R	$\sqrt{3}$	1	1	1.5	1.5	∞
9	RF ambient conditions-noise	B	0	R	$\sqrt{3}$	1	1	0	0	∞
10	RFambient conditions-reflection	B	0	R	$\sqrt{3}$	1	1	0	0	∞
11	Probe positioned mech. restrictions	B	0.4	R	$\sqrt{3}$	1	1	0.2	0.2	∞
12	Probe positioning with respect to phantom shell	B	2.9	R	$\sqrt{3}$	1	1	1.7	1.7	∞
13	Post-processing	B	1.0	R	$\sqrt{3}$	1	1	0.6	0.6	∞
Test sample related										
14	Test sample positioning	A	3.3	N	1	1	1	3.3	3.3	71
15	Device holder uncertainty	A	3.4	N	1	1	1	3.4	3.4	5
16	Drift of output power	B	5.0	R	$\sqrt{3}$	1	1	2.9	2.9	∞
Phantom and set-up										
17	Phantom uncertainty	B	4.0	R	$\sqrt{3}$	1	1	2.3	2.3	∞
18	Liquid conductivity (target)	B	5.0	R	$\sqrt{3}$	0.64	0.43	1.8	1.2	∞
19	Liquid conductivity (meas.)	A	2.06	N	1	0.64	0.43	1.32	0.89	43
20	Liquid permittivity (target)	B	5.0	R	$\sqrt{3}$	0.6	0.49	1.7	1.4	∞
21	Liquid permittivity (meas.)	A	1.6	N	1	0.6	0.49	1.0	0.8	521

Combined standard uncertainty	$u_c = \sqrt{\sum_{i=1}^{21} c_i^2 u_i^2}$							9.55	9.43	257
Expanded uncertainty (confidence interval of 95 %)	$u_e = 2u_c$							19.1	18.9	

16.2 Measurement Uncertainty for Normal SAR Tests (3~6GHz)

No.	Error Description	Type	Uncertainty value	Probably Distribution	Div.	(Ci) 1g	(Ci) 10g	Std. Unc. (1g)	Std. Unc. (10g)	Degree of freedom
Measurement system										
1	Probe calibration	B	6.55	N	1	1	1	6.55	6.55	∞
2	Isotropy	B	4.7	R	$\sqrt{3}$	0.7	0.7	1.9	1.9	∞
3	Boundary effect	B	2.0	R	$\sqrt{3}$	1	1	1.2	1.2	∞
4	Linearity	B	4.7	R	$\sqrt{3}$	1	1	2.7	2.7	∞
5	Detection limit	B	1.0	R	$\sqrt{3}$	1	1	0.6	0.6	∞
6	Readout electronics	B	0.3	R	$\sqrt{3}$	1	1	0.3	0.3	∞
7	Response time	B	0.8	R	$\sqrt{3}$	1	1	0.5	0.5	∞
8	Integration time	B	2.6	R	$\sqrt{3}$	1	1	1.5	1.5	∞
9	RF ambient conditions-noise	B	0	R	$\sqrt{3}$	1	1	0	0	∞
10	RFambient conditions-reflection	B	0	R	$\sqrt{3}$	1	1	0	0	∞
11	Probe positioned mech. restrictions	B	0.8	R	$\sqrt{3}$	1	1	0.5	0.5	∞
12	Probe positioning with respect to phantom shell	B	6.7	R	$\sqrt{3}$	1	1	3.9	3.9	∞
13	Post-processing	B	4.0	R	$\sqrt{3}$	1	1	2.3	2.3	∞
Test sample related										
14	Test sample positioning	A	3.3	N	1	1	1	3.3	3.3	71
15	Device holder uncertainty	A	3.4	N	1	1	1	3.4	3.4	5
16	Drift of output power	B	5.0	R	$\sqrt{3}$	1	1	2.9	2.9	∞
Phantom and set-up										
17	Phantom uncertainty	B	4.0	R	$\sqrt{3}$	1	1	2.3	2.3	∞
18	Liquid conductivity (target)	B	5.0	R	$\sqrt{3}$	0.64	0.43	1.8	1.2	∞
19	Liquid conductivity (meas.)	A	2.06	N	1	0.64	0.43	1.32	0.89	43
20	Liquid permittivity	B	5.0	R	$\sqrt{3}$	0.6	0.49	1.7	1.4	∞

	(target)									
21	Liquid permittivity (meas.)	A	1.6	N	1	0.6	0.49	1.0	0.8	521
Combined standard uncertainty		$u_c = \sqrt{\sum_{i=1}^{21} c_i^2 u_i^2}$						10.7	10.6	257
Expanded uncertainty (confidence interval of 95 %)		$u_e = 2u_c$						21.4	21.1	

16.3 Measurement Uncertainty for Fast SAR Tests (300MHz~3GHz)

No.	Error Description	Type	Uncertainty value	Probably Distribution	Div.	(Ci) 1g	(Ci) 10g	Std. Unc. (1g)	Std. Unc. (10g)	Degree of freedom
Measurement system										
1	Probe calibration	B	6.0	N	1	1	1	6.0	6.0	∞
2	Isotropy	B	4.7	R	$\sqrt{3}$	0.7	0.7	1.9	1.9	∞
3	Boundary effect	B	1.0	R	$\sqrt{3}$	1	1	0.6	0.6	∞
4	Linearity	B	4.7	R	$\sqrt{3}$	1	1	2.7	2.7	∞
5	Detection limit	B	1.0	R	$\sqrt{3}$	1	1	0.6	0.6	∞
6	Readout electronics	B	0.3	R	$\sqrt{3}$	1	1	0.3	0.3	∞
7	Response time	B	0.8	R	$\sqrt{3}$	1	1	0.5	0.5	∞
8	Integration time	B	2.6	R	$\sqrt{3}$	1	1	1.5	1.5	∞
9	RF ambient conditions-noise	B	0	R	$\sqrt{3}$	1	1	0	0	∞
10	RFambient conditions-reflection	B	0	R	$\sqrt{3}$	1	1	0	0	∞
11	Probe positioned mech. Restrictions	B	0.4	R	$\sqrt{3}$	1	1	0.2	0.2	∞
12	Probe positioning with respect to phantom shell	B	2.9	R	$\sqrt{3}$	1	1	1.7	1.7	∞
13	Post-processing	B	1.0	R	$\sqrt{3}$	1	1	0.6	0.6	∞
14	Fast SAR z-Approximation	B	7.0	R	$\sqrt{3}$	1	1	4.0	4.0	∞
Test sample related										
15	Test sample positioning	A	3.3	N	1	1	1	3.3	3.3	71
16	Device holder uncertainty	A	3.4	N	1	1	1	3.4	3.4	5
17	Drift of output power	B	5.0	R	$\sqrt{3}$	1	1	2.9	2.9	∞
Phantom and set-up										
18	Phantom uncertainty	B	4.0	R	$\sqrt{3}$	1	1	2.3	2.3	∞

19	Liquid conductivity (target)	B	5.0	R	$\sqrt{3}$	0.64	0.43	1.8	1.2	∞
20	Liquid conductivity (meas.)	A	2.06	N	1	0.64	0.43	1.32	0.89	43
21	Liquid permittivity (target)	B	5.0	R	$\sqrt{3}$	0.6	0.49	1.7	1.4	∞
22	Liquid permittivity (meas.)	A	1.6	N	1	0.6	0.49	1.0	0.8	521
Combined standard uncertainty		$u_c = \sqrt{\sum_{i=1}^{22} c_i^2 u_i^2}$						10.4	10.3	257
Expanded uncertainty (confidence interval of 95 %)		$u_e = 2u_c$						20.8	20.6	

16.4 Measurement Uncertainty for Fast SAR Tests (3~6GHz)

No.	Error Description	Type	Uncertainty value	Probably Distribution	Div.	(Ci) 1g	(Ci) 10g	Std. Unc. (1g)	Std. Unc. (10g)	Degree of freedom
Measurement system										
1	Probe calibration	B	6.55	N	1	1	1	6.55	6.55	∞
2	Isotropy	B	4.7	R	$\sqrt{3}$	0.7	0.7	1.9	1.9	∞
3	Boundary effect	B	2.0	R	$\sqrt{3}$	1	1	1.2	1.2	∞
4	Linearity	B	4.7	R	$\sqrt{3}$	1	1	2.7	2.7	∞
5	Detection limit	B	1.0	R	$\sqrt{3}$	1	1	0.6	0.6	∞
6	Readout electronics	B	0.3	R	$\sqrt{3}$	1	1	0.3	0.3	∞
7	Response time	B	0.8	R	$\sqrt{3}$	1	1	0.5	0.5	∞
8	Integration time	B	2.6	R	$\sqrt{3}$	1	1	1.5	1.5	∞
9	RF ambient conditions-noise	B	0	R	$\sqrt{3}$	1	1	0	0	∞
10	RF ambient conditions-reflection	B	0	R	$\sqrt{3}$	1	1	0	0	∞
11	Probe positioned mech. Restrictions	B	0.8	R	$\sqrt{3}$	1	1	0.5	0.5	∞
12	Probe positioning with respect to phantom shell	B	6.7	R	$\sqrt{3}$	1	1	3.9	3.9	∞
13	Post-processing	B	1.0	R	$\sqrt{3}$	1	1	0.6	0.6	∞
14	Fast SAR z-Approximation	B	14.0	R	$\sqrt{3}$	1	1	8.1	8.1	∞
Test sample related										
15	Test sample positioning	A	3.3	N	1	1	1	3.3	3.3	71

16	Device holder uncertainty	A	3.4	N	1	1	1	3.4	3.4	5
17	Drift of output power	B	5.0	R	$\sqrt{3}$	1	1	2.9	2.9	∞
Phantom and set-up										
18	Phantom uncertainty	B	4.0	R	$\sqrt{3}$	1	1	2.3	2.3	∞
19	Liquid conductivity (target)	B	5.0	R	$\sqrt{3}$	0.64	0.43	1.8	1.2	∞
20	Liquid conductivity (meas.)	A	2.06	N	1	0.64	0.43	1.32	0.89	43
21	Liquid permittivity (target)	B	5.0	R	$\sqrt{3}$	0.6	0.49	1.7	1.4	∞
22	Liquid permittivity (meas.)	A	1.6	N	1	0.6	0.49	1.0	0.8	521
Combined standard uncertainty		$u_c = \sqrt{\sum_{i=1}^{22} c_i^2 u_i^2}$						13.5	13.4	257
Expanded uncertainty (confidence interval of 95 %)		$u_e = 2u_c$						27.0	26.8	

17 MAIN TEST INSTRUMENTS

Table 17.1: List of Main Instruments

No.	Name	Type	Serial Number	Calibration Date	Valid Period
01	Network analyzer	N5239A	MY55491241	June 10, 2019	One year
02	Power meter	NRP2	106277	September 4, 2019	One year
03	Power sensor	NRP8S	104291		
04	Signal Generator	E4438C	MG3700A	June 18, 2019	One Year
05	Amplifier	60S1G4	0331848	No Calibration Requested	
06	BTS	CMW500	166370	June 27, 2019	One year
07	E-field Probe	SPEAG EX3DV4	3617	January 31, 2019	One year
08	DAE	SPEAG DAE4	1289	April 11,2019	One year
09	Dipole Validation Kit	SPEAG D835V2	4d069	July 18,2019	One year
10	Dipole Validation Kit	SPEAG D1750V2	1003	July 16,2019	One year
11	Dipole Validation Kit	SPEAG D1900V2	5d101	July 17,2019	One year
12	Dipole Validation Kit	SPEAG D2450V2	853	July 17,2019	One year
13	Dipole Validation Kit	SPEAG D2600V2	1012	July 17,2019	One year
14	Dipole Validation Kit	SPEAG D5GHZV2	1060	July 22, 2019	One year

END OF REPORT BODY

ANNEX A Graph Results

GSM850_CH251 Right Tilt

Date: 1/6/2020

Electronics: DAE4 Sn1289

Medium: head 835 MHz

Medium parameters used: $f = 848.8$; $\sigma = 0.905$ mho/m; $\epsilon_r = 41.32$; $\rho = 1000$ kg/m³

Ambient Temperature: 22.5°C, Liquid Temperature: 22.3°C

Communication System: GSM850 848.8 Duty Cycle: 1: 8.3

Probe: EX3DV4 – SN3617 ConvF(9.75,9.75,9.75)

Area Scan (71x121x1): Interpolated grid: dx=1.000 mm, dy=1.000 mm

Maximum value of SAR (interpolated) = 1.3 W/kg

Zoom Scan (7x7x7)/Cube 0: Measurement grid: dx=5mm, dy=5mm, dz=5mm

Reference Value = 16.49 V/m; Power Drift = 0.07 dB

Peak SAR (extrapolated) = 1.62 W/kg

SAR(1 g) = 0.566 W/kg; SAR(10 g) = 0.259 W/kg

Maximum value of SAR (measured) = 1.05 W/kg

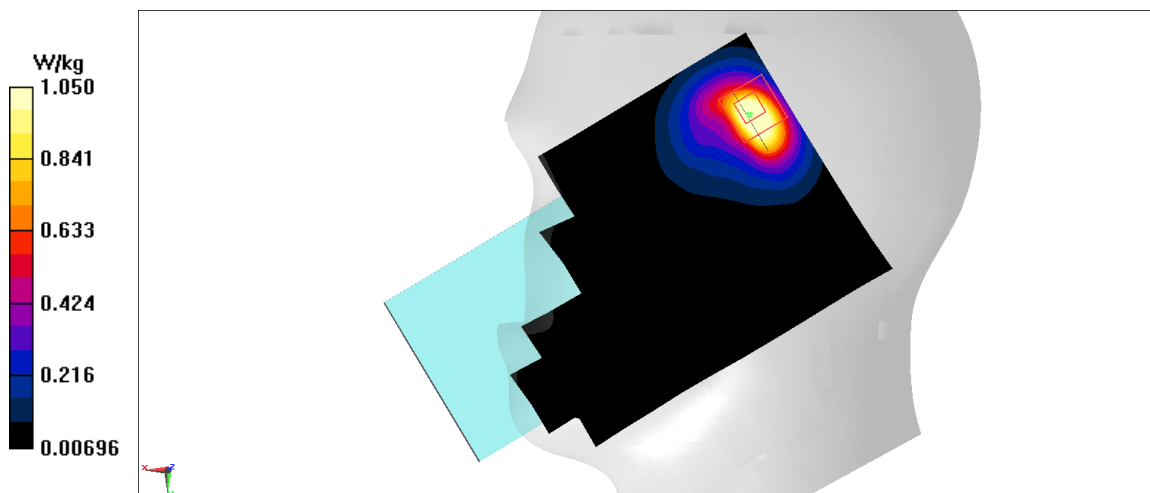

Fig A.1

GSM850_CH128 Rear

Date: 1/6/2020

Electronics: DAE4 Sn1289

Medium: body 835 MHz

Medium parameters used: $f = 824.2$; $\sigma = 0.882$ mho/m; $\epsilon_r = 41.35$; $\rho = 1000$ kg/m³

Ambient Temperature: 22.5°C, Liquid Temperature: 22.3°C

Communication System: GSM850 824.2 Duty Cycle: 1: 8.3

Probe: EX3DV4 – SN3617 ConvF(9.75,9.75,9.75)

Area Scan (71x121x1): Interpolated grid: dx=1.000 mm, dy=1.000 mm

Maximum value of SAR (interpolated) = 0.0738 W/kg

Zoom Scan (7x7x7)/Cube 0: Measurement grid: dx=5mm, dy=5mm, dz=5mm

Reference Value = 4.679 V/m; Power Drift = 0.02 dB

Peak SAR (extrapolated) = 0.123 W/kg

SAR(1 g) = 0.071 W/kg; SAR(10 g) = 0.042 W/kg

Maximum value of SAR (measured) = 0.076 W/kg

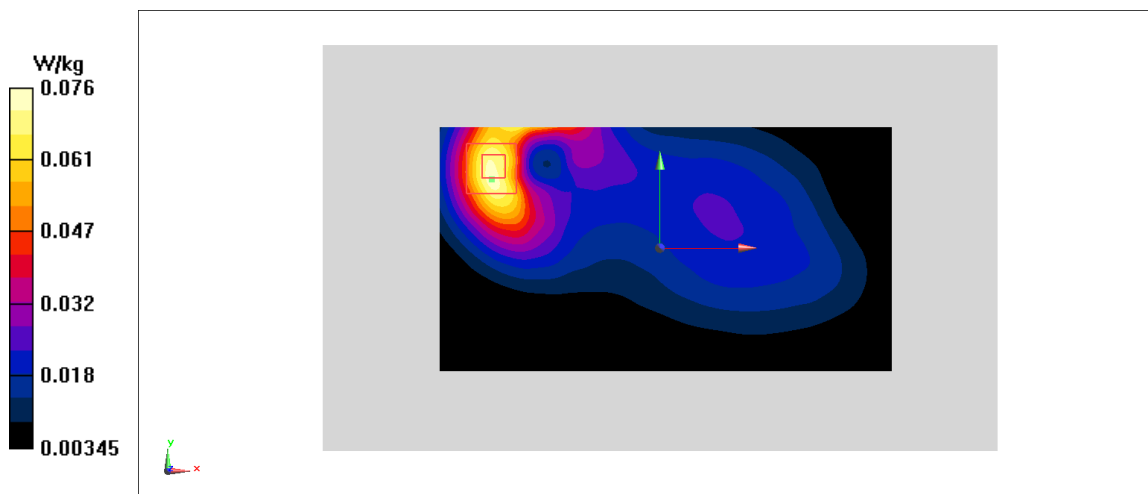
**Fig A.2**

PCS1900_CH512 Right Cheek

Date: 1/10/2020

Electronics: DAE4 Sn1289

Medium: head 1900 MHz

Medium parameters used: $f = 1850.2$; $\sigma = 1.352$ mho/m; $\epsilon_r = 40.6$; $\rho = 1000$ kg/m³

Ambient Temperature: 22.5°C, Liquid Temperature: 22.3°C

Communication System: PCS1900 1850.2 Duty Cycle: 1: 8.3

Probe: EX3DV4 – SN3617 ConvF(8.14,8.14,8.14)

Area Scan (71x121x1): Interpolated grid: dx=1.000 mm, dy=1.000 mm

Maximum value of SAR (interpolated) = 1.01 W/kg

Zoom Scan (7x7x7)/Cube 0: Measurement grid: dx=5mm, dy=5mm, dz=5mm

Reference Value = 8.165 V/m; Power Drift = -0.11 dB

Peak SAR (extrapolated) = 1.16 W/kg

SAR(1 g) = 0.55 W/kg; SAR(10 g) = 0.286 W/kg

Maximum value of SAR (measured) = 0.908 W/kg

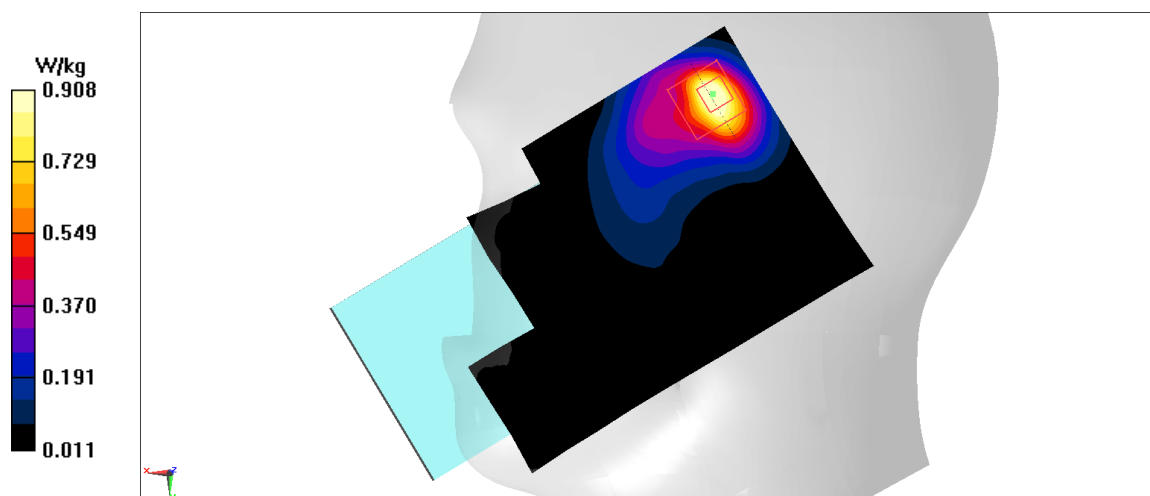

Fig A.3

PCS1900_CH512 Left

Date: 1/10/2020

Electronics: DAE4 Sn1289

Medium: body 1900 MHz

Medium parameters used: $f = 1850.2$; $\sigma = 1.352$ mho/m; $\epsilon_r = 40.6$; $\rho = 1000$ kg/m³

Ambient Temperature: 22.5°C, Liquid Temperature: 22.3°C

Communication System: PCS1900 1850.2 Duty Cycle: 1: 4

Probe: EX3DV4 – SN3617 ConvF(8.14,8.14,8.14)

Area Scan (71x121x1): Interpolated grid: dx=1.000 mm, dy=1.000 mm

Maximum value of SAR (interpolated) = 0.338 W/kg

Zoom Scan (7x7x7)/Cube 0: Measurement grid: dx=5mm, dy=5mm, dz=5mm

Reference Value = 11.63 V/m; Power Drift = 0.13 dB

Peak SAR (extrapolated) = 0.562 W/kg

SAR(1 g) = 0.294 W/kg; SAR(10 g) = 0.147 W/kg

Maximum value of SAR (measured) = 0.333 W/kg

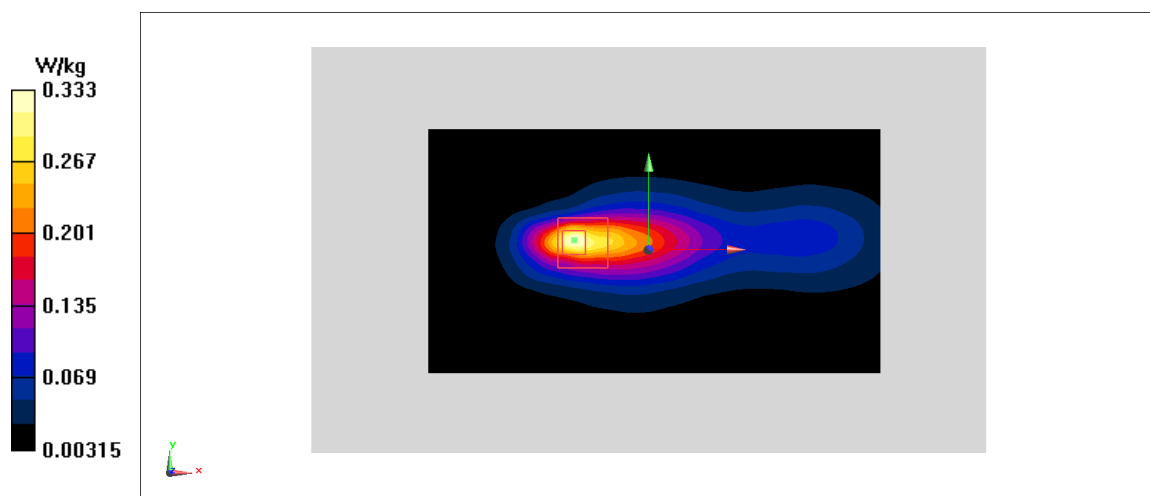
**Fig A.4**

WCDMA1900-BII_CH9262 Right Cheek

Date: 1/10/2020

Electronics: DAE4 Sn1289

Medium: head 1900 MHz

Medium parameters used: $f = 1852.4$; $\sigma = 1.354$ mho/m; $\epsilon_r = 40.6$; $\rho = 1000$ kg/m³

Ambient Temperature: 22.5°C, Liquid Temperature: 22.3°C

Communication System: WCDMA1900-BII 1852.4 Duty Cycle: 1: 1

Probe: EX3DV4 – SN3617 ConvF(8.14,8.14,8.14)

Area Scan (71x121x1): Interpolated grid: dx=1.000 mm, dy=1.000 mm

Maximum value of SAR (interpolated) = 0.891 W/kg

Zoom Scan (7x7x7)/Cube 0: Measurement grid: dx=5mm, dy=5mm, dz=5mm

Reference Value = 10.17 V/m; Power Drift = 0 dB

Peak SAR (extrapolated) = 1.08 W/kg

SAR(1 g) = 0.492 W/kg; SAR(10 g) = 0.269 W/kg

Maximum value of SAR (measured) = 0.866 W/kg

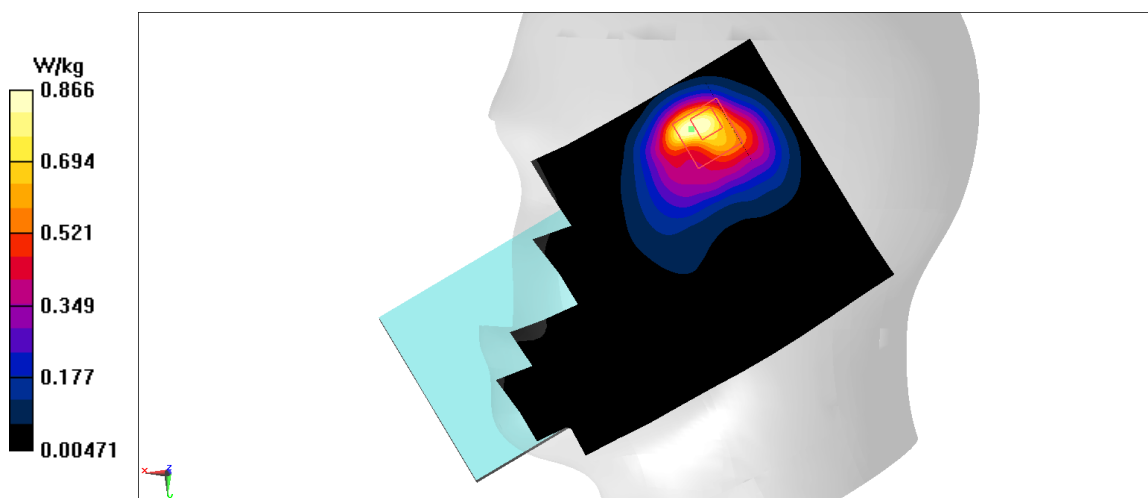

Fig A.5

WCDMA1900-BII_CH9400 Left

Date: 1/10/2020

Electronics: DAE4 Sn1289

Medium: body 1900 MHz

Medium parameters used: $f = 1880$; $\sigma = 1.381$ mho/m; $\epsilon_r = 40.56$; $\rho = 1000$ kg/m³

Ambient Temperature: 22.5°C, Liquid Temperature: 22.3°C

Communication System: WCDMA1900-BII 1880 Duty Cycle: 1: 1

Probe: EX3DV4 – SN3617 ConvF(8.14,8.14,8.14)

Area Scan (71x121x1): Interpolated grid: dx=1.000 mm, dy=1.000 mm

Maximum value of SAR (interpolated) = 0.735 W/kg

Zoom Scan (7x7x7)/Cube 0: Measurement grid: dx=5mm, dy=5mm, dz=5mm

Reference Value = 9.762 V/m; Power Drift = -0.04 dB

Peak SAR (extrapolated) = 1.26 W/kg

SAR(1 g) = 0.593 W/kg; SAR(10 g) = 0.269 W/kg

Maximum value of SAR (measured) = 0.658 W/kg

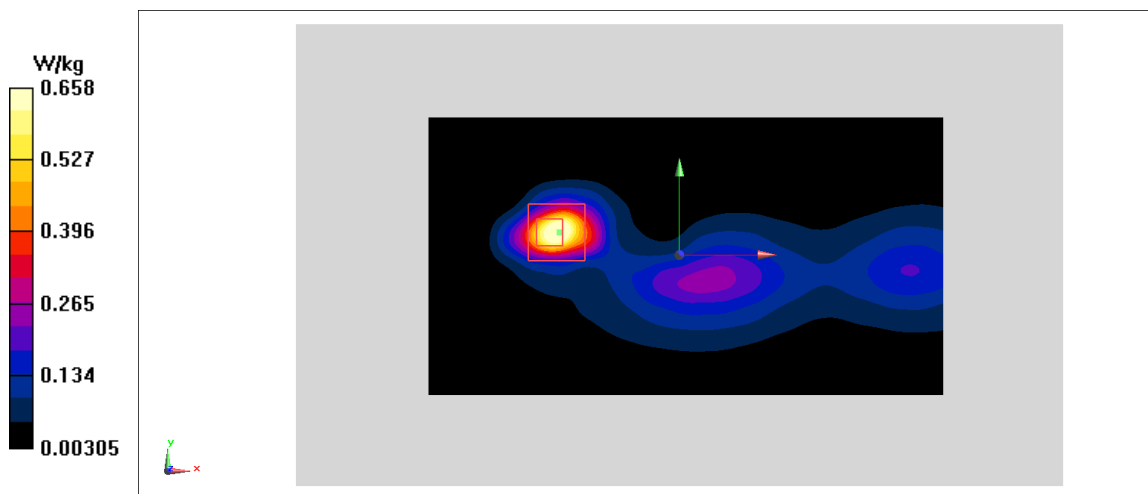

Fig A.6

WCDMA1700-BIV_CH1513 Right Cheek

Date: 1/8/2020

Electronics: DAE4 Sn1289

Medium: head 1750 MHz

Medium parameters used: $f = 1752.6$; $\sigma = 1.377$ mho/m; $\epsilon_r = 40.66$; $\rho = 1000$ kg/m³

Ambient Temperature: 22.5°C, Liquid Temperature: 22.3°C

Communication System: WCDMA1700-BIV 1752.6 Duty Cycle: 1: 1

Probe: EX3DV4 – SN3617 ConvF(8.38,8.38,8.38)

Area Scan (71x121x1): Interpolated grid: dx=1.000 mm, dy=1.000 mm

Maximum value of SAR (interpolated) = 1.08 W/kg

Zoom Scan (7x7x7)/Cube 0: Measurement grid: dx=5mm, dy=5mm, dz=5mm

Reference Value = 11.93 V/m; Power Drift = -0.04 dB

Peak SAR (extrapolated) = 1.41 W/kg

SAR(1 g) = 0.609 W/kg; SAR(10 g) = 0.326 W/kg

Maximum value of SAR (measured) = 1.02 W/kg

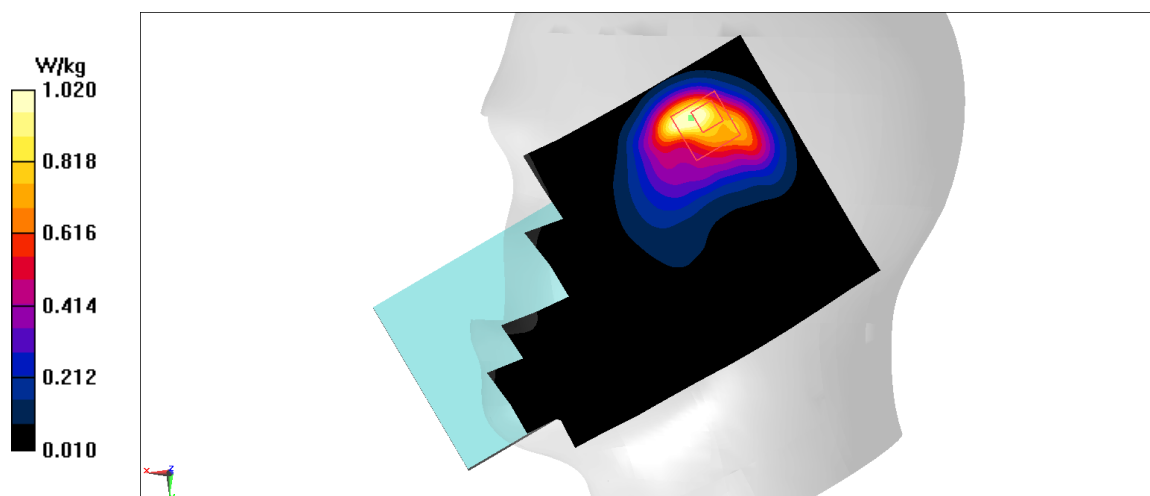

Fig A.7

WCDMA1700-BIV_CH1312 Left

Date: 1/8/2020

Electronics: DAE4 Sn1289

Medium: body 1750 MHz

Medium parameters used: $f = 1712.4$; $\sigma = 1.338$ mho/m; $\epsilon_r = 40.71$; $\rho = 1000$ kg/m³

Ambient Temperature: 22.5°C, Liquid Temperature: 22.3°C

Communication System: WCDMA1700-BIV 1712.4 Duty Cycle: 1: 1

Probe: EX3DV4 – SN3617 ConvF(8.38,8.38,8.38)

Area Scan (71x121x1): Interpolated grid: dx=1.000 mm, dy=1.000 mm

Maximum value of SAR (interpolated) = 0.316 W/kg

Zoom Scan (7x7x7)/Cube 0: Measurement grid: dx=5mm, dy=5mm, dz=5mm

Reference Value = 13.08 V/m; Power Drift = 0.12 dB

Peak SAR (extrapolated) = 0.53 W/kg

SAR(1 g) = 0.29 W/kg; SAR(10 g) = 0.155 W/kg

Maximum value of SAR (measured) = 0.331 W/kg

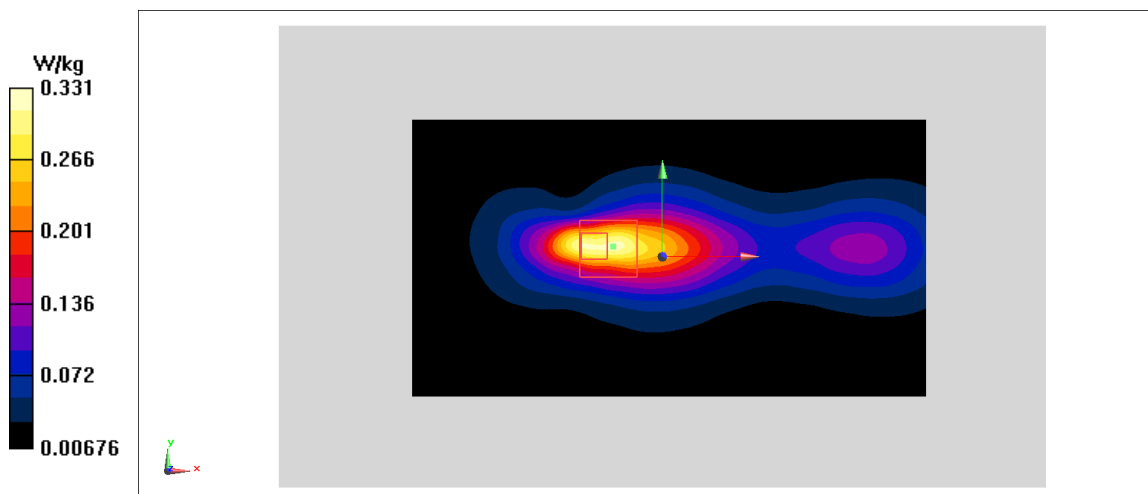

Fig A.8

WCDMA850-BV_CH4132 Right Tilt

Date: 1/7/2020

Electronics: DAE4 Sn1289

Medium: head 835 MHz

Medium parameters used: $f = 826.4$; $\sigma = 0.896$ mho/m; $\epsilon_r = 42.27$; $\rho = 1000$ kg/m³

Ambient Temperature: 22.5°C, Liquid Temperature: 22.3°C

Communication System: WCDMA850-BV 826.4 Duty Cycle: 1:1

Probe: EX3DV4 – SN3617 ConvF(9.75,9.75,9.75)

Area Scan (71x121x1): Interpolated grid: dx=1.000 mm, dy=1.000 mm

Maximum value of SAR (interpolated) = 1.31 W/kg

Zoom Scan (7x7x7)/Cube 0: Measurement grid: dx=5mm, dy=5mm, dz=5mm

Reference Value = 16.77 V/m; Power Drift = 0.09 dB

Peak SAR (extrapolated) = 1.65 W/kg

SAR(1 g) = 0.568 W/kg; SAR(10 g) = 0.259 W/kg

Maximum value of SAR (measured) = 1.05 W/kg

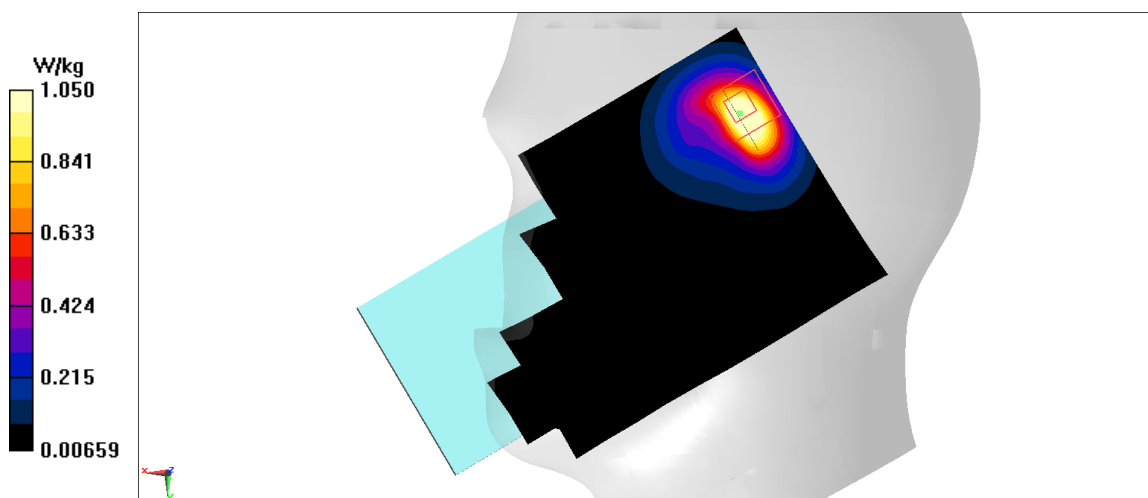

Fig A.9

WCDMA850-BV_CH4183 Front

Date: 1/7/2020

Electronics: DAE4 Sn1289

Medium: body 835 MHz

Medium parameters used: $f = 836.6$; $\sigma = 0.907$ mho/m; $\epsilon_r = 42.26$; $\rho = 1000$ kg/m³

Ambient Temperature: 22.5°C, Liquid Temperature: 22.3°C

Communication System: WCDMA850-BV 836.6 Duty Cycle: 1:1

Probe: EX3DV4 – SN3617 ConvF(9.75,9.75,9.75)

Area Scan (71x121x1): Interpolated grid: dx=1.000 mm, dy=1.000 mm

Maximum value of SAR (interpolated) = 0.208 W/kg

Zoom Scan (7x7x7)/Cube 0: Measurement grid: dx=5mm, dy=5mm, dz=5mm

Reference Value = 6.033 V/m; Power Drift = -0.13 dB

Peak SAR (extrapolated) = 0.414 W/kg

SAR(1 g) = 0.213 W/kg; SAR(10 g) = 0.116 W/kg

Maximum value of SAR (measured) = 0.221 W/kg

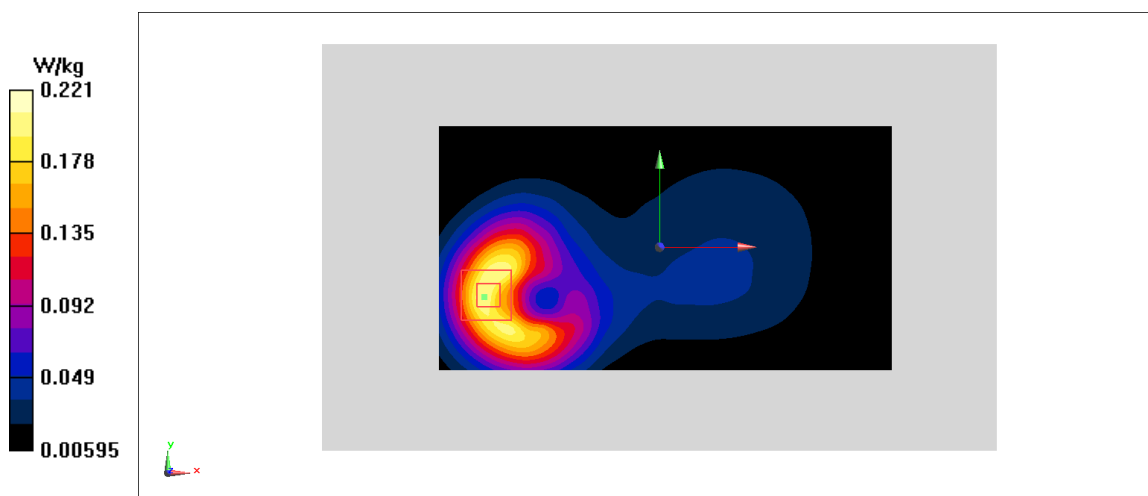
**Fig A.10**

LTE1900-FDD2_CH19100 Right Cheek

Date: 1/11/2020

Electronics: DAE4 Sn1289

Medium: head 1900 MHz

Medium parameters used: $f = 1900 \text{ MHz}$; $\sigma = 1.385 \text{ mho/m}$; $\epsilon_r = 39.78$; $\rho = 1000 \text{ kg/m}^3$

Ambient Temperature: 22.5°C , Liquid Temperature: 22.3°C

Communication System: LTE1900-FDD2 1900 MHz Duty Cycle: 1:1

Probe: EX3DV4 – SN3617 ConvF(8.14,8.14,8.14)

Area Scan (71x121x1): Interpolated grid: $dx=1.000 \text{ mm}$, $dy=1.000 \text{ mm}$

Maximum value of SAR (interpolated) = 0.983 W/kg

Zoom Scan (7x7x7)/Cube 0: Measurement grid: $dx=5\text{mm}$, $dy=5\text{mm}$, $dz=5\text{mm}$

Reference Value = 9.53 V/m ; Power Drift = -0.09 dB

Peak SAR (extrapolated) = 1.13 W/kg

SAR(1 g) = 0.554 W/kg ; SAR(10 g) = 0.284 W/kg

Maximum value of SAR (measured) = 0.885 W/kg

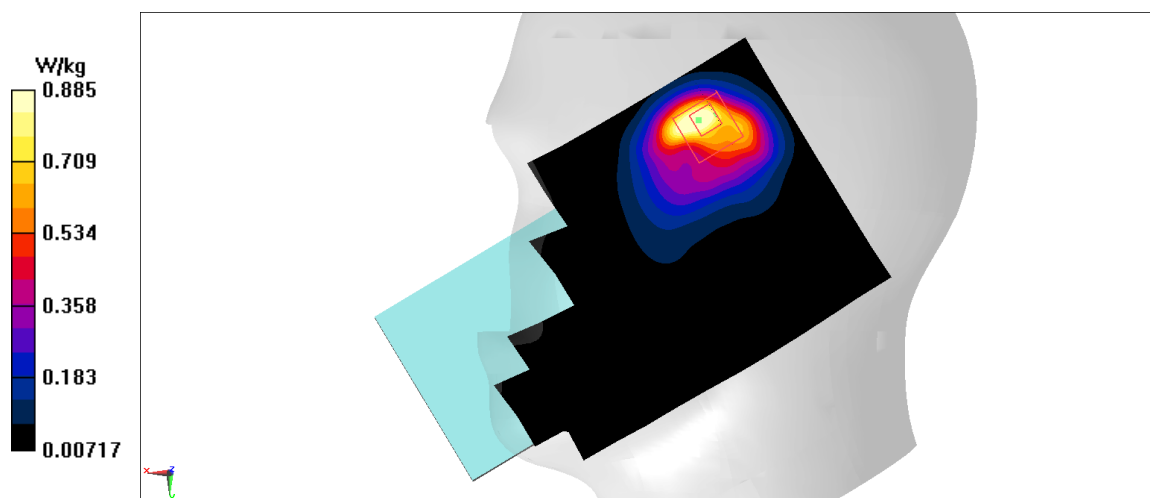

Fig A.11

LTE1900-FDD2_CH18700 Left

Date: 1/11/2020

Electronics: DAE4 Sn1289

Medium: body 1900 MHz

Medium parameters used: $f = 1860$ MHz; $\sigma = 1.347$ mho/m; $\epsilon_r = 39.83$; $\rho = 1000$ kg/m³

Ambient Temperature: 22.5°C, Liquid Temperature: 22.3°C

Communication System: LTE1900-FDD2 1860 MHz Duty Cycle: 1:1

Probe: EX3DV4 – SN3617 ConvF(8.14,8.14,8.14)

Area Scan (71x121x1): Interpolated grid: dx=1.000 mm, dy=1.000 mm

Maximum value of SAR (interpolated) = 0.504 W/kg

Zoom Scan (7x7x7)/Cube 0: Measurement grid: dx=5mm, dy=5mm, dz=5mm

Reference Value = 7.496 V/m; Power Drift = -0.01 dB

Peak SAR (extrapolated) = 0.861 W/kg

SAR(1 g) = 0.407 W/kg; SAR(10 g) = 0.189 W/kg

Maximum value of SAR (measured) = 0.449 W/kg

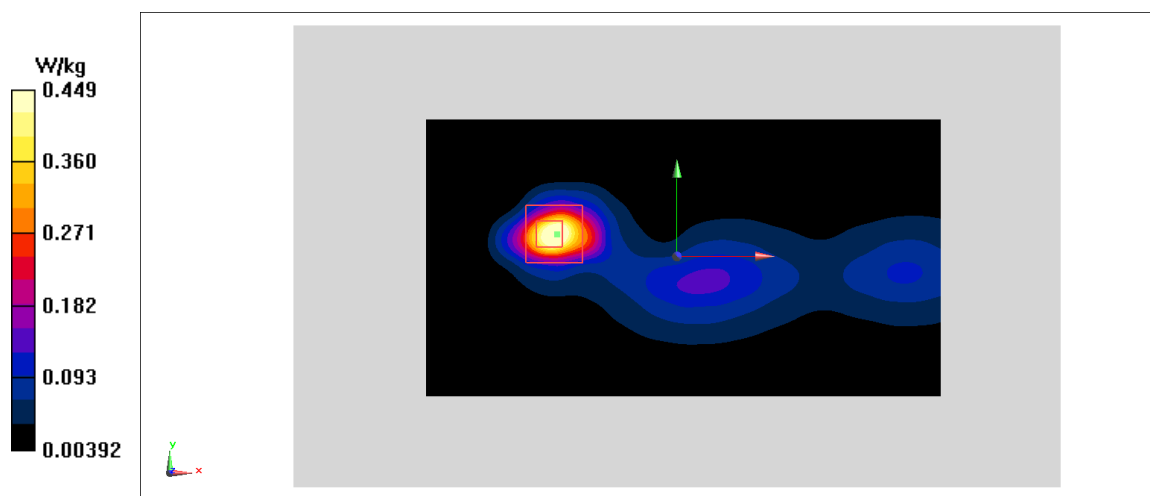

Fig A.12

LTE1700-FDD4_CH20300 Right Cheek

Date: 1/9/2020

Electronics: DAE4 Sn1289

Medium: head 1750 MHz

Medium parameters used: $f = 1745 \text{ MHz}$; $\sigma = 1.392 \text{ mho/m}$; $\epsilon_r = 40.08$; $\rho = 1000 \text{ kg/m}^3$

Ambient Temperature: 22.5°C , Liquid Temperature: 22.3°C

Communication System: LTE1700-FDD4 1745 MHz Duty Cycle: 1:1

Probe: EX3DV4 – SN3617 ConvF(8.38,8.38,8.38)

Area Scan (71x121x1): Interpolated grid: $dx=1.000 \text{ mm}$, $dy=1.000 \text{ mm}$

Maximum value of SAR (interpolated) = 0.84 W/kg

Zoom Scan (7x7x7)/Cube 0: Measurement grid: $dx=5\text{mm}$, $dy=5\text{mm}$, $dz=5\text{mm}$

Reference Value = 10.33 V/m ; Power Drift = -0.07 dB

Peak SAR (extrapolated) = 1.06 W/kg

SAR(1 g) = 0.494 W/kg ; SAR(10 g) = 0.258 W/kg

Maximum value of SAR (measured) = 0.824 W/kg

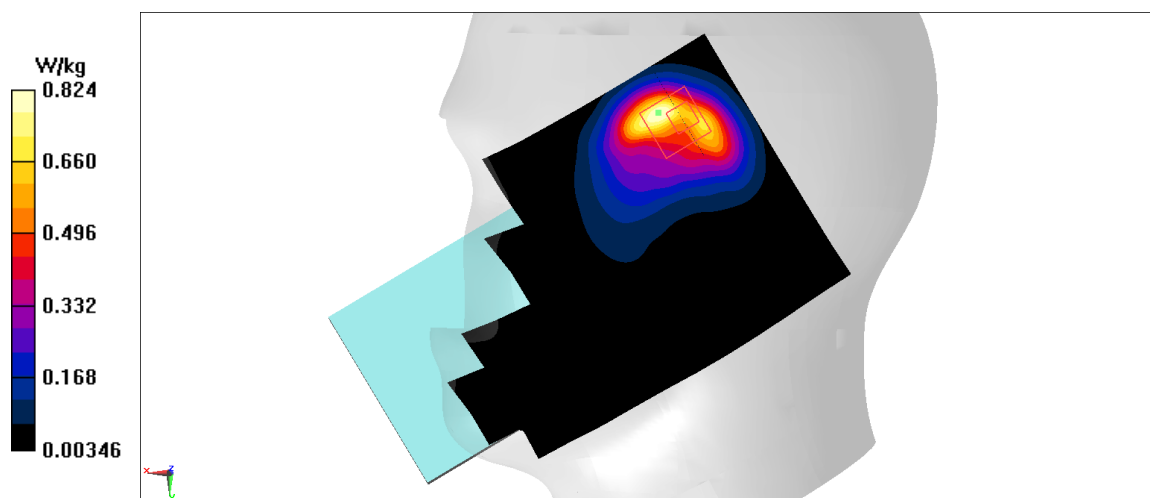

Fig A.13

LTE1700-FDD4_CH20300 Left

Date: 1/9/2020

Electronics: DAE4 Sn1289

Medium: body 1750 MHz

Medium parameters used: $f = 1745$ MHz; $\sigma = 1.392$ mho/m; $\epsilon_r = 40.08$; $\rho = 1000$ kg/m³

Ambient Temperature: 22.5°C, Liquid Temperature: 22.3°C

Communication System: LTE1700-FDD4 1745 MHz Duty Cycle: 1:1

Probe: EX3DV4 – SN3617 ConvF(8.38,8.38,8.38)

Area Scan (71x121x1): Interpolated grid: dx=1.000 mm, dy=1.000 mm

Maximum value of SAR (interpolated) = 0.188 W/kg

Zoom Scan (7x7x7)/Cube 0: Measurement grid: dx=5mm, dy=5mm, dz=5mm

Reference Value = 6.716 V/m; Power Drift = -0.12 dB

Peak SAR (extrapolated) = 0.319 W/kg

SAR(1 g) = 0.181 W/kg; SAR(10 g) = 0.098 W/kg

Maximum value of SAR (measured) = 0.196 W/kg

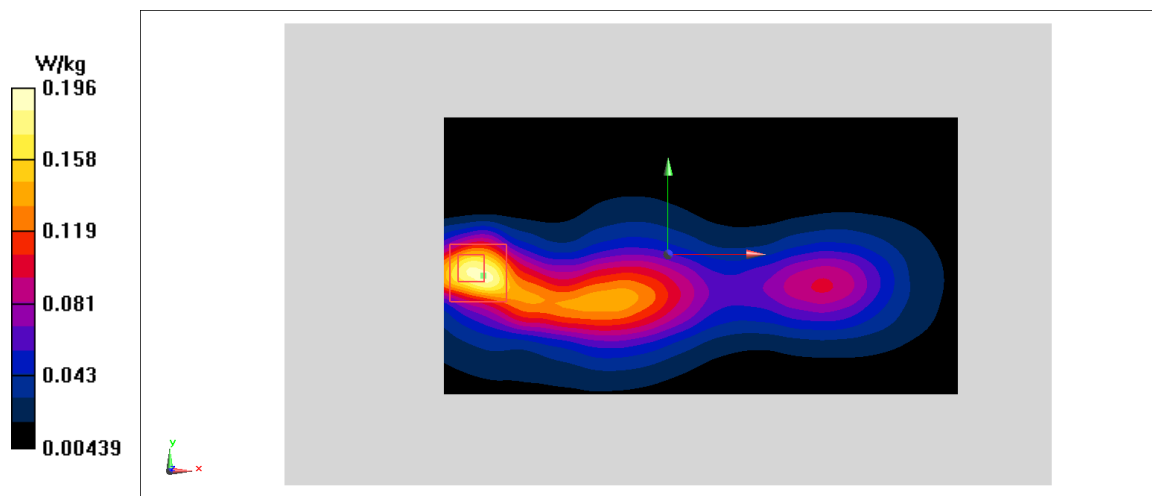

Fig A.14

LTE850-FDD5_CH20450 Right Tilt

Date: 1/6/2020

Electronics: DAE4 Sn1289

Medium: head 835 MHz

Medium parameters used: $f = 829$ MHz; $\sigma = 0.886$ mho/m; $\epsilon_r = 41.35$; $\rho = 1000$ kg/m³

Ambient Temperature: 22.5°C, Liquid Temperature: 22.3°C

Communication System: LTE850-FDD5 829 MHz Duty Cycle: 1: 1

Probe: EX3DV4 – SN3617 ConvF(9.75,9.75,9.75)

Area Scan (71x121x1): Interpolated grid: dx=1.000 mm, dy=1.000 mm

Maximum value of SAR (interpolated) = 0.744 W/kg

Zoom Scan (7x7x7)/Cube 0: Measurement grid: dx=5mm, dy=5mm, dz=5mm

Reference Value = 16.83 V/m; Power Drift = 0.04 dB

Peak SAR (extrapolated) = 1.51 W/kg

SAR(1 g) = 0.514 W/kg; SAR(10 g) = 0.239 W/kg

Maximum value of SAR (measured) = 1.02 W/kg

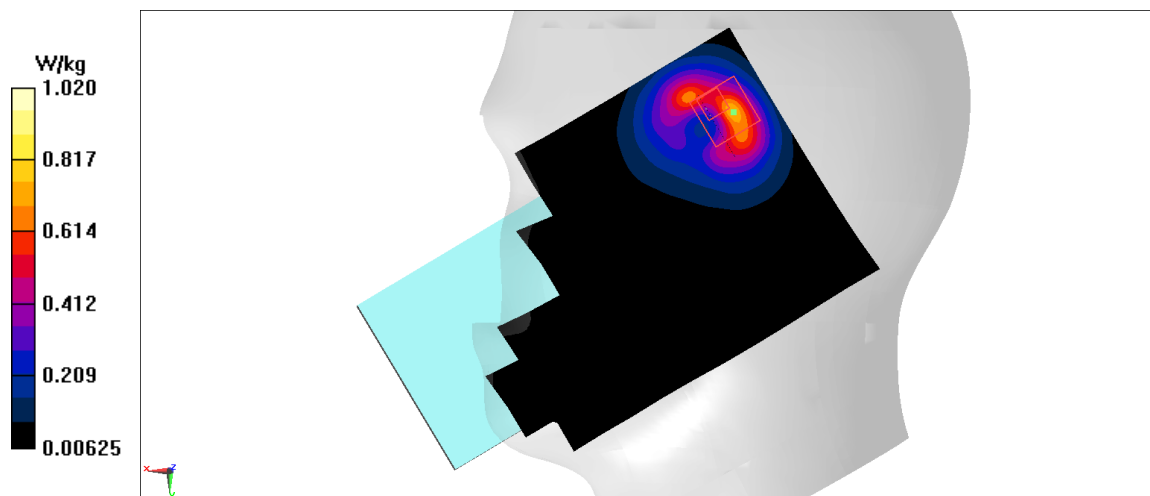

Fig A.15

LTE850-FDD5_CH20450 Left

Date: 1/6/2020

Electronics: DAE4 Sn1289

Medium: body 835 MHz

Medium parameters used: $f = 829$ MHz; $\sigma = 0.886$ mho/m; $\epsilon_r = 41.35$; $\rho = 1000$ kg/m³

Ambient Temperature: 22.5°C, Liquid Temperature: 22.3°C

Communication System: LTE850-FDD5 829 MHz Duty Cycle: 1: 1

Probe: EX3DV4 – SN3617 ConvF(9.75,9.75,9.75)

Area Scan (71x121x1): Interpolated grid: dx=1.000 mm, dy=1.000 mm

Maximum value of SAR (interpolated) = 0.296 W/kg

Zoom Scan (7x7x7)/Cube 0: Measurement grid: dx=5mm, dy=5mm, dz=5mm

Reference Value = 5.995 V/m; Power Drift = -0.01 dB

Peak SAR (extrapolated) = 0.366 W/kg

SAR(1 g) = 0.18 W/kg; SAR(10 g) = 0.074 W/kg

Maximum value of SAR (measured) = 0.277 W/kg

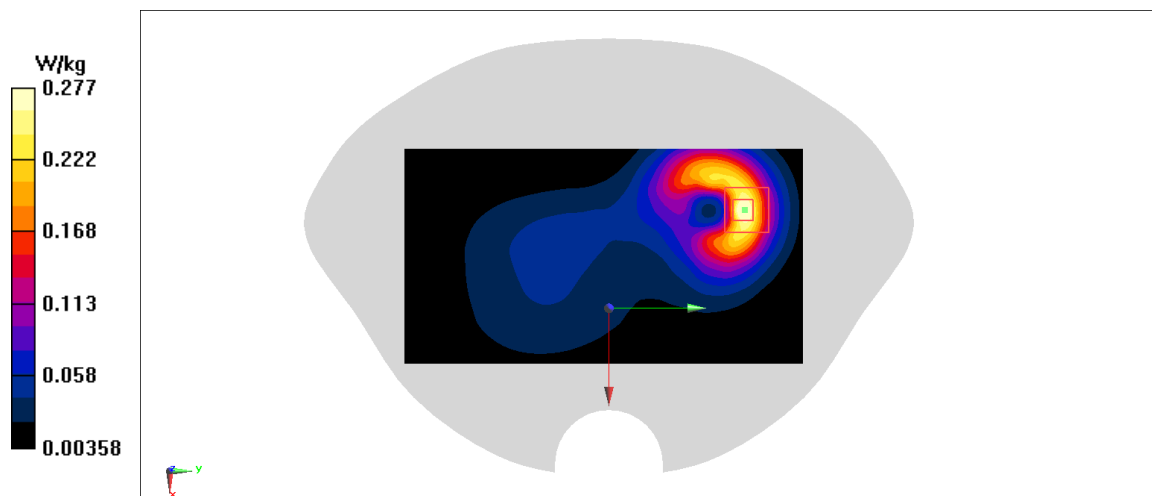
**Fig A.16**

LTE2500-FDD7_CH21100 Right Cheek

Date: 1/15/2020

Electronics: DAE4 Sn1289

Medium: head 2600 MHz

Medium parameters used: $f = 2535$ MHz; $\sigma = 1.916$ mho/m; $\epsilon_r = 38.87$; $\rho = 1000$ kg/m³

Ambient Temperature: 22.5°C, Liquid Temperature: 22.3°C

Communication System: LTE2500-FDD7 2535 MHz Duty Cycle: 1:1

Probe: EX3DV4 – SN3617 ConvF(7.19,7.19,7.19)

Area Scan (71x121x1): Interpolated grid: dx=1.000 mm, dy=1.000 mm

Maximum value of SAR (interpolated) = 1.24 W/kg

Zoom Scan (7x7x7)/Cube 0: Measurement grid: dx=5mm, dy=5mm, dz=5mm

Reference Value = 6.351 V/m; Power Drift = 0.16 dB

Peak SAR (extrapolated) = 1.59 W/kg

SAR(1 g) = 0.621 W/kg; SAR(10 g) = 0.255 W/kg

Maximum value of SAR (measured) = 1.2 W/kg

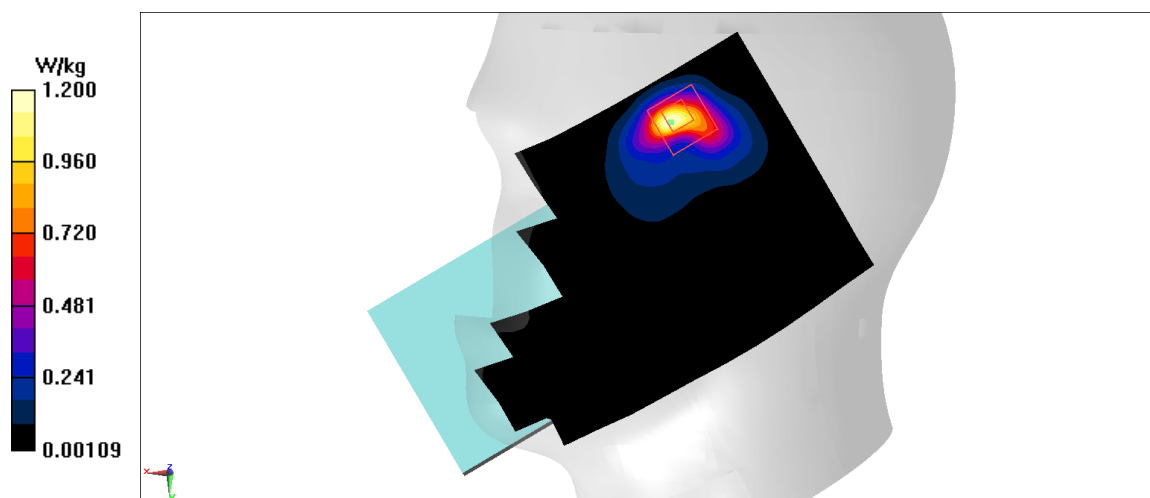

Fig A.17

LTE2500-FDD7_CH21100 Left

Date: 1/15/2020

Electronics: DAE4 Sn1289

Medium: body 2600 MHz

Medium parameters used: $f = 2535$ MHz; $\sigma = 1.916$ mho/m; $\epsilon_r = 38.87$; $\rho = 1000$ kg/m³

Ambient Temperature: 22.5°C, Liquid Temperature: 22.3°C

Communication System: LTE2500-FDD7 2535 MHz Duty Cycle: 1:1

Probe: EX3DV4 – SN3617 ConvF(7.19,7.19,7.19)

Area Scan (71x121x1): Interpolated grid: dx=1.000 mm, dy=1.000 mm

Maximum value of SAR (interpolated) = 1.09 W/kg

Zoom Scan (7x7x7)/Cube 0: Measurement grid: dx=5mm, dy=5mm, dz=5mm

Reference Value = 10.53 V/m; Power Drift = 0.09 dB

Peak SAR (extrapolated) = 1.51 W/kg

SAR(1 g) = 0.695 W/kg; SAR(10 g) = 0.313 W/kg

Maximum value of SAR (measured) = 1.17 W/kg

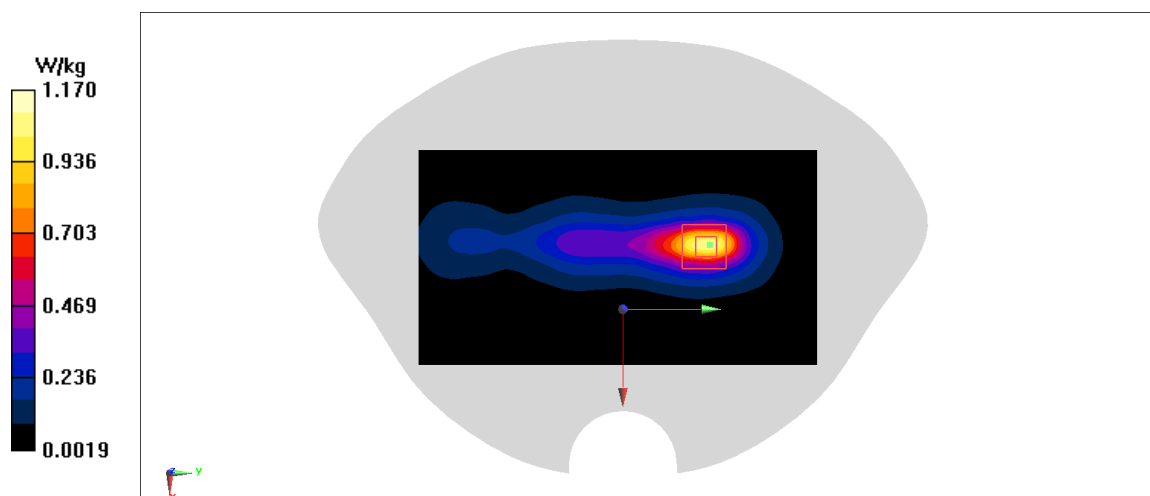

Fig A.18

LTE2600-TDD38_CH38150 Right Cheek

Date: 1/14/2020

Electronics: DAE4 Sn1289

Medium: head 2600 MHz

Medium parameters used: $f = 2610$ MHz; $\sigma = 1.947$ mho/m; $\epsilon_r = 39.11$; $\rho = 1000$ kg/m³

Ambient Temperature: 22.5°C, Liquid Temperature: 22.3°C

Communication System: LTE2600-TDD38 2610 MHz Duty Cycle: 1:1.58

Probe: EX3DV4 – SN3617 ConvF(7.19,7.19,7.19)

Area Scan (71x121x1): Interpolated grid: dx=1.000 mm, dy=1.000 mm

Maximum value of SAR (interpolated) = 1.64 W/kg

Zoom Scan (7x7x7)/Cube 0: Measurement grid: dx=5mm, dy=5mm, dz=5mm

Reference Value = 4.124 V/m; Power Drift = 0.03 dB

Peak SAR (extrapolated) = 1.71 W/kg

SAR(1 g) = 0.663 W/kg; SAR(10 g) = 0.245 W/kg

Maximum value of SAR (measured) = 1.14 W/kg

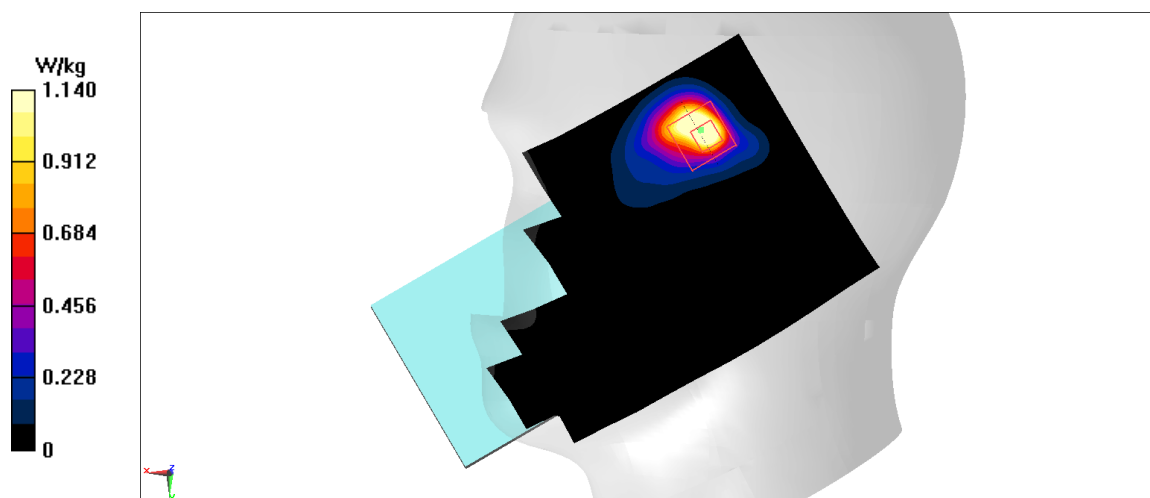

Fig A.19

LTE2600-TDD38_CH38150 Left

Date: 1/14/2020

Electronics: DAE4 Sn1289

Medium: head 2600 MHz

 Medium parameters used: $f = 2610$ MHz; $\sigma = 1.947$ mho/m; $\epsilon_r = 39.11$; $\rho = 1000$ kg/m³

Ambient Temperature: 22.5°C, Liquid Temperature: 22.3°C

Communication System: LTE2600-TDD38 2610 MHz Duty Cycle: 1:1.58

Probe: EX3DV4 – SN3617 ConvF(7.49,7.49,7.49)

Area Scan (71x121x1): Interpolated grid: dx=1.000 mm, dy=1.000 mm

Maximum value of SAR (interpolated) = 0.633 W/kg

Zoom Scan (7x7x7)/Cube 0: Measurement grid: dx=5mm, dy=5mm, dz=5mm

Reference Value = 7.669 V/m; Power Drift = 0.02 dB

Peak SAR (extrapolated) = 0.895 W/kg

SAR(1 g) = 0.398 W/kg; SAR(10 g) = 0.17 W/kg

Maximum value of SAR (measured) = 0.661 W/kg

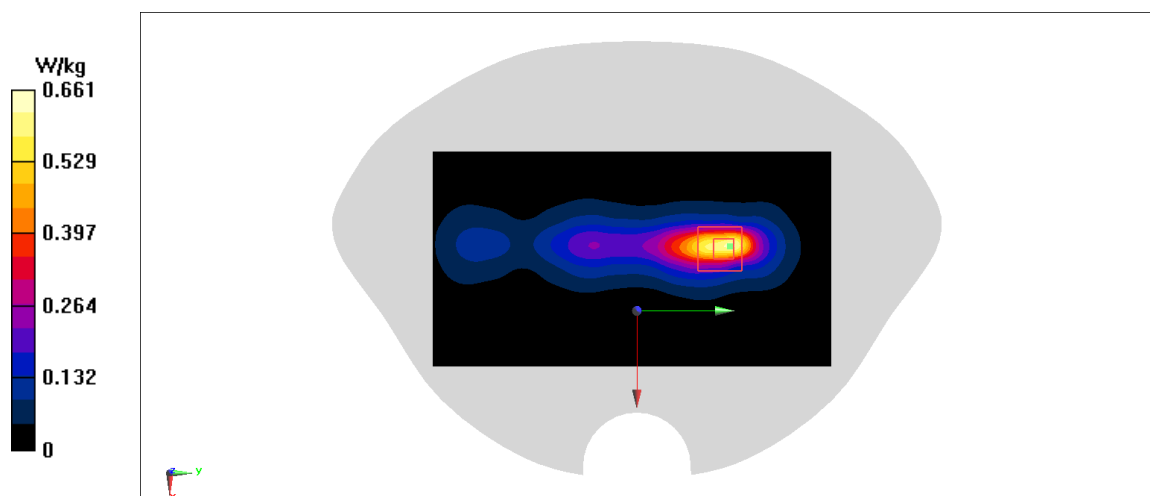
Fig A.20

PCS1900_CH512 Right Cheek

Date: 1/10/2020

Electronics: DAE4 Sn1289

Medium: head 1900 MHz

Medium parameters used: $f = 1850.2$; $\sigma = 1.352$ mho/m; $\epsilon_r = 40.6$; $\rho = 1000$ kg/m³

Ambient Temperature: 22.5°C, Liquid Temperature: 22.3°C

Communication System: PCS1900 1850.2 Duty Cycle: 1: 8.3

Probe: EX3DV4 – SN3617 ConvF(8.14,8.14,8.14)

Area Scan (71x121x1): Interpolated grid: dx=1.000 mm, dy=1.000 mm

Maximum value of SAR (interpolated) = 0.112 W/kg

Zoom Scan (7x7x7)/Cube 0: Measurement grid: dx=5mm, dy=5mm, dz=5mm

Reference Value = 2.515 V/m; Power Drift = 0.07 dB

Peak SAR (extrapolated) = 0.129 W/kg

SAR(1 g) = 0.083 W/kg; SAR(10 g) = 0.049 W/kg

Maximum value of SAR (measured) = 0.112 W/kg

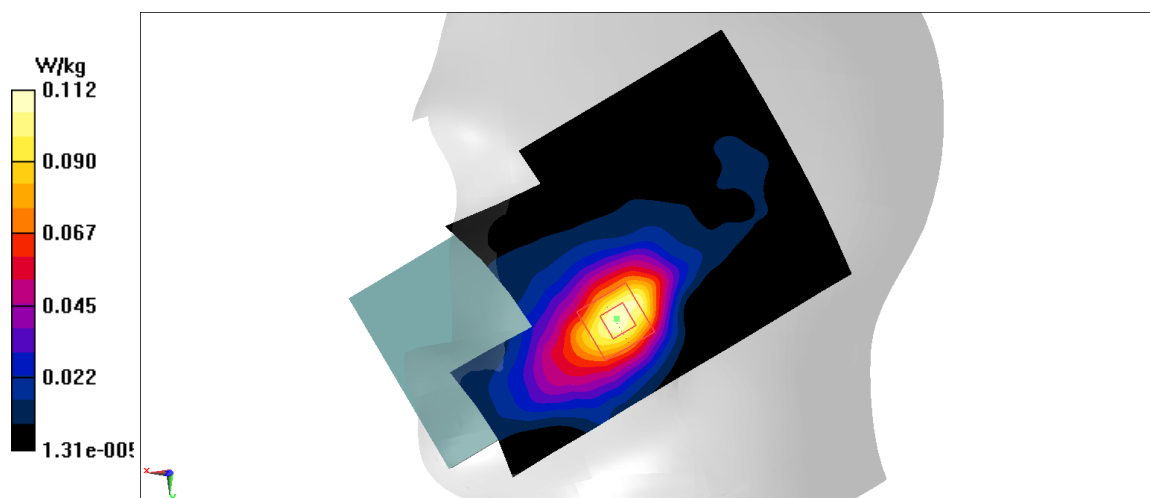

Fig A.21

PCS1900_CH512 Bottom

Date: 1/10/2020

Electronics: DAE4 Sn1289

Medium: body 1900 MHz

Medium parameters used: $f = 1850.2$; $\sigma = 1.352$ mho/m; $\epsilon_r = 40.6$; $\rho = 1000$ kg/m³

Ambient Temperature: 22.5°C, Liquid Temperature: 22.3°C

Communication System: PCS1900 1850.2 Duty Cycle: 1: 8.3

Probe: EX3DV4 – SN3617 ConvF(8.14,8.14,8.14)

Area Scan (71x121x1): Interpolated grid: dx=1.000 mm, dy=1.000 mm

Maximum value of SAR (interpolated) = 1.18 W/kg

Zoom Scan (7x7x7)/Cube 0: Measurement grid: dx=5mm, dy=5mm, dz=5mm

Reference Value = 24.98 V/m; Power Drift = -0.03 dB

Peak SAR (extrapolated) = 1.43 W/kg

SAR(1 g) = 0.747 W/kg; SAR(10 g) = 0.366 W/kg

Maximum value of SAR (measured) = 1.12 W/kg

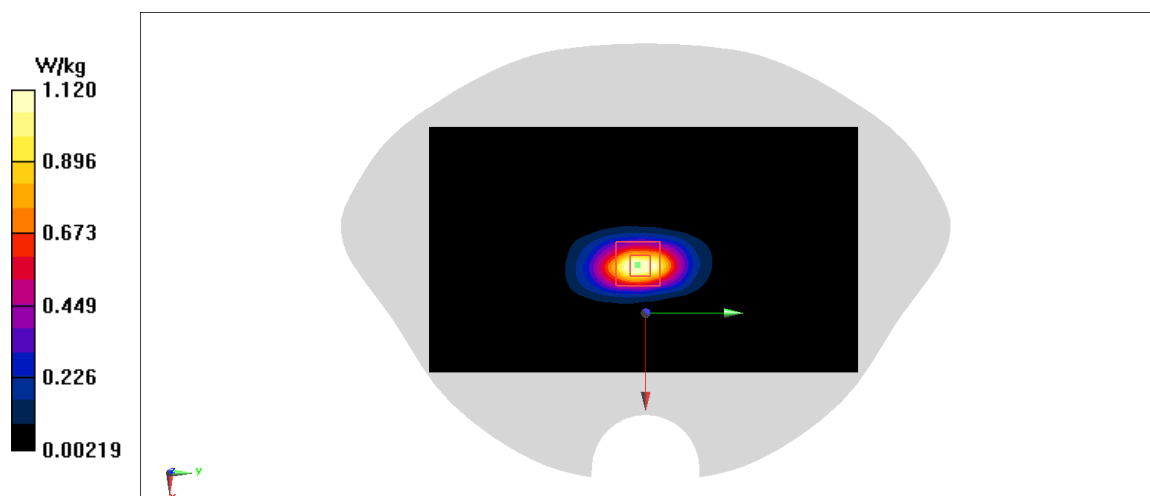

Fig A.22

PCS1900_CH661 Front

Date: 1/10/2020

Electronics: DAE4 Sn1289

Medium: body 1900 MHz

Medium parameters used: $f = 1880$; $\sigma = 1.381$ mho/m; $\epsilon_r = 40.56$; $\rho = 1000$ kg/m³

Ambient Temperature: 22.5°C, Liquid Temperature: 22.3°C

Communication System: PCS1900 1880 Duty Cycle: 1: 4

Probe: EX3DV4 – SN3617 ConvF(8.14,8.14,8.14)

Area Scan (71x121x1): Interpolated grid: dx=1.000 mm, dy=1.000 mm

Maximum value of SAR (interpolated) = 0.299 W/kg

Zoom Scan (7x7x7)/Cube 0: Measurement grid: dx=5mm, dy=5mm, dz=5mm

Reference Value = 4.575 V/m; Power Drift = 0.08 dB

Peak SAR (extrapolated) = 0.364 W/kg

SAR(1 g) = 0.213 W/kg; SAR(10 g) = 0.116 W/kg

Maximum value of SAR (measured) = 0.304 W/kg

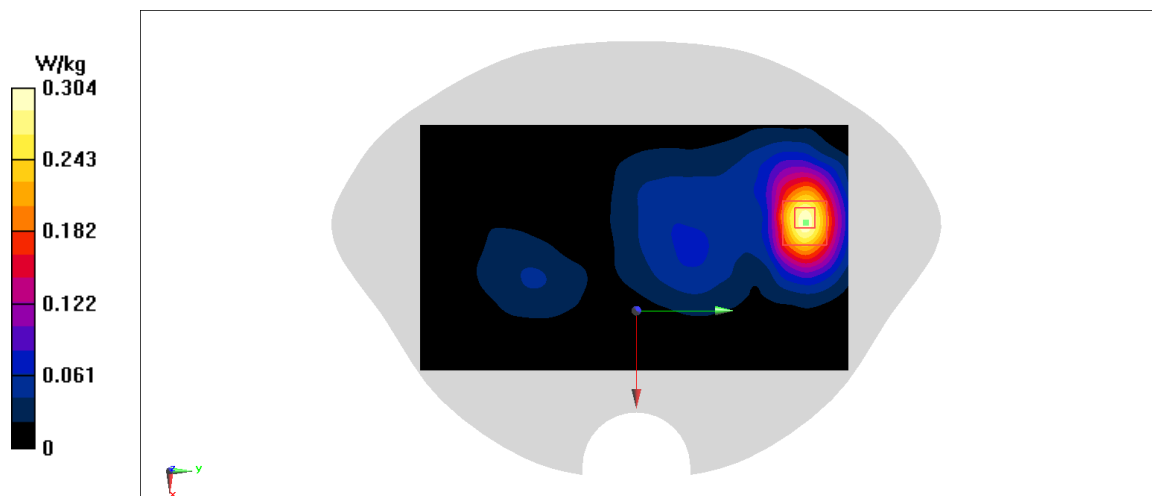

Fig A.23

WCDMA1900-BII_CH9262 Right Cheek

Date: 1/10/2020

Electronics: DAE4 Sn1289

Medium: head 1900 MHz

Medium parameters used: $f = 1852.4$; $\sigma = 1.354$ mho/m; $\epsilon_r = 40.6$; $\rho = 1000$ kg/m³

Ambient Temperature: 22.5°C, Liquid Temperature: 22.3°C

Communication System: WCDMA1900-BII 1852.4 Duty Cycle: 1: 1

Probe: EX3DV4 – SN3617 ConvF(8.14,8.14,8.14)

Area Scan (71x121x1): Interpolated grid: dx=1.000 mm, dy=1.000 mm

Maximum value of SAR (interpolated) = 0.223 W/kg

Zoom Scan (7x7x7)/Cube 0: Measurement grid: dx=5mm, dy=5mm, dz=5mm

Reference Value = 3.306 V/m; Power Drift = 0.07 dB

Peak SAR (extrapolated) = 0.248 W/kg

SAR(1 g) = 0.168 W/kg; SAR(10 g) = 0.106 W/kg

Maximum value of SAR (measured) = 0.208 W/kg

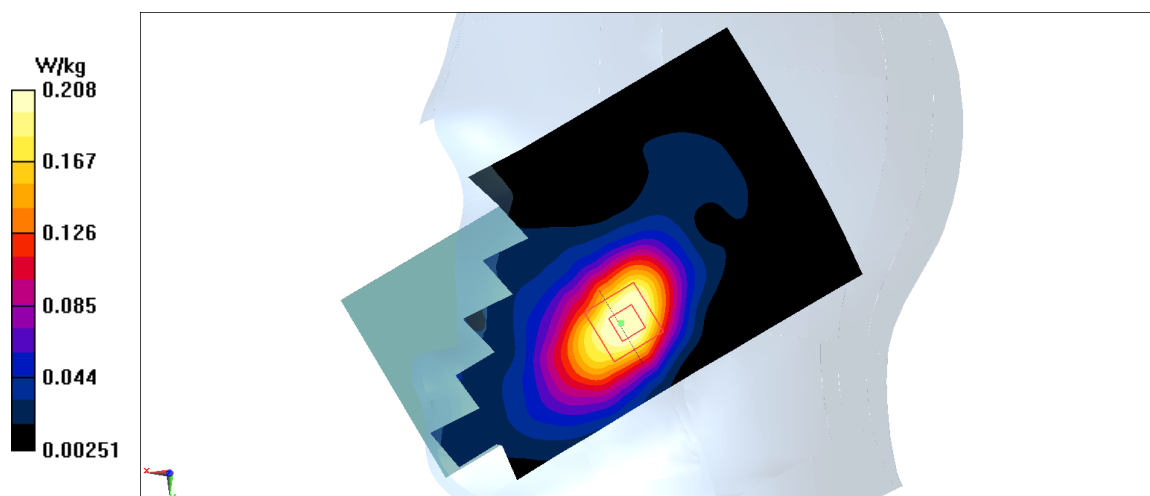

Fig A.24

WCDMA1900-BII_CH9262 Bottom

Date: 1/10/2020

Electronics: DAE4 Sn1289

Medium: body 1900 MHz

 Medium parameters used: $f = 1852.4$; $\sigma = 1.354$ mho/m; $\epsilon_r = 40.6$; $\rho = 1000$ kg/m³

Ambient Temperature: 22.5°C, Liquid Temperature: 22.3°C

Communication System: WCDMA1900-BII 1852.4 Duty Cycle: 1: 1

Probe: EX3DV4 – SN3617 ConvF(8.14,8.14,8.14)

Area Scan (71x121x1): Interpolated grid: dx=1.000 mm, dy=1.000 mm

Maximum value of SAR (interpolated) = 1.18 W/kg

Zoom Scan (7x7x7)/Cube 0: Measurement grid: dx=5mm, dy=5mm, dz=5mm

Reference Value = 19.59 V/m; Power Drift = 0.08 dB

Peak SAR (extrapolated) = 1.36 W/kg

SAR(1 g) = 0.713 W/kg; SAR(10 g) = 0.356 W/kg

Maximum value of SAR (measured) = 1.1 W/kg

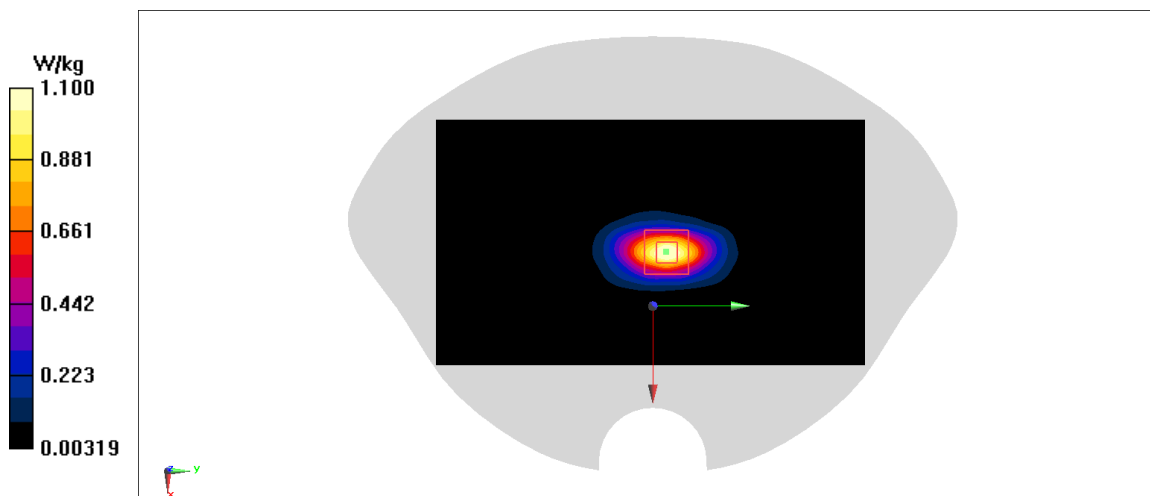

Fig A.25

WCDMA1900-BII_CH9262 Front

Date: 1/10/2020

Electronics: DAE4 Sn1289

Medium: body 1900 MHz

Medium parameters used: $f = 1852.4$; $\sigma = 1.354$ mho/m; $\epsilon_r = 40.6$; $\rho = 1000$ kg/m³

Ambient Temperature: 22.5°C, Liquid Temperature: 22.3°C

Communication System: WCDMA1900-BII 1852.4 Duty Cycle: 1: 1

Probe: EX3DV4 – SN3617 ConvF(8.14,8.14,8.14)

Area Scan (71x121x1): Interpolated grid: dx=1.000 mm, dy=1.000 mm

Maximum value of SAR (interpolated) = 1.1 W/kg

Zoom Scan (7x7x7)/Cube 0: Measurement grid: dx=5mm, dy=5mm, dz=5mm

Reference Value = 9.391 V/m; Power Drift = -0.02 dB

Peak SAR (extrapolated) = 1.31 W/kg

SAR(1 g) = 0.757 W/kg; SAR(10 g) = 0.421 W/kg

Maximum value of SAR (measured) = 1.03 W/kg

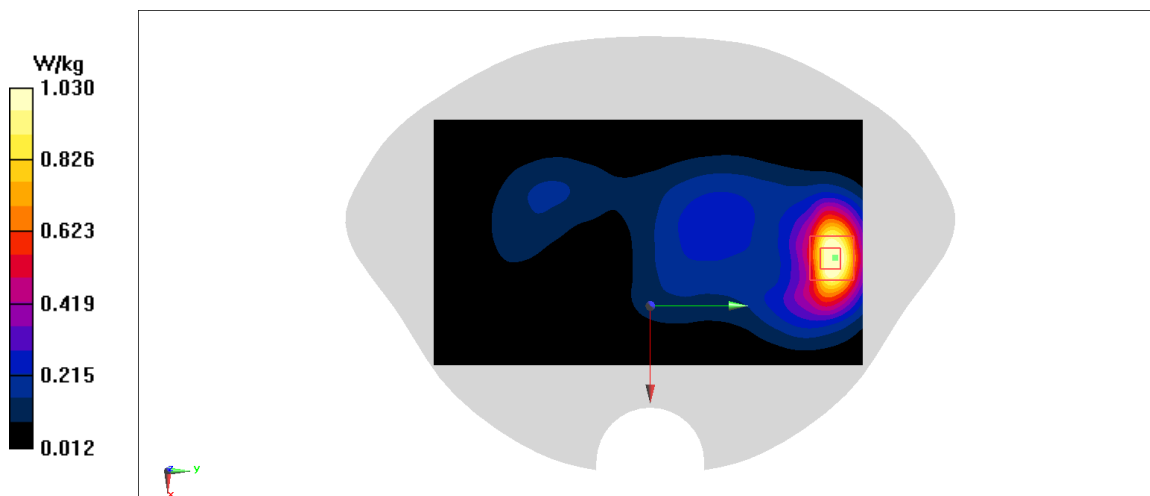

Fig A.26

WCDMA1700-BIV_CH1412 Right Cheek

Date: 1/8/2020

Electronics: DAE4 Sn1289

Medium: head 1750 MHz

Medium parameters used: $f = 1732.4$; $\sigma = 1.357$ mho/m; $\epsilon_r = 40.68$; $\rho = 1000$ kg/m³

Ambient Temperature: 22.5°C, Liquid Temperature: 22.3°C

Communication System: WCDMA1700-BIV 1732.4 Duty Cycle: 1: 1

Probe: EX3DV4 – SN3617 ConvF(8.38,8.38,8.38)

Area Scan (71x121x1): Interpolated grid: dx=1.000 mm, dy=1.000 mm

Maximum value of SAR (interpolated) = 0.219 W/kg

Zoom Scan (7x7x7)/Cube 0: Measurement grid: dx=5mm, dy=5mm, dz=5mm

Reference Value = 4.501 V/m; Power Drift = -0.08 dB

Peak SAR (extrapolated) = 0.235 W/kg

SAR(1 g) = 0.152 W/kg; SAR(10 g) = 0.095 W/kg

Maximum value of SAR (measured) = 0.162 W/kg

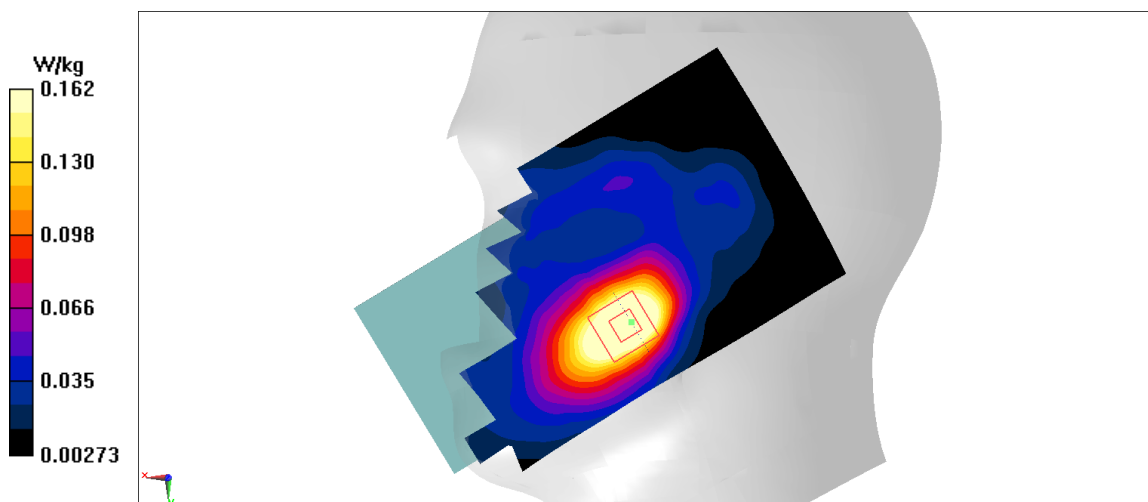

Fig A.27

WCDMA1700-BIV_CH1513 Bottom

Date: 1/8/2020

Electronics: DAE4 Sn1289

Medium: body 1750 MHz

Medium parameters used: $f = 1752.6$; $\sigma = 1.377$ mho/m; $\epsilon_r = 40.66$; $\rho = 1000$ kg/m³

Ambient Temperature: 22.5°C, Liquid Temperature: 22.3°C

Communication System: WCDMA1700-BIV 1752.6 Duty Cycle: 1: 1

Probe: EX3DV4 – SN3617 ConvF(8.38,8.38,8.38)

Area Scan (71x121x1): Interpolated grid: dx=1.000 mm, dy=1.000 mm

Maximum value of SAR (interpolated) = 1.19 W/kg

Zoom Scan (7x7x7)/Cube 0: Measurement grid: dx=5mm, dy=5mm, dz=5mm

Reference Value = 19.5 V/m; Power Drift = -0.02 dB

Peak SAR (extrapolated) = 1.4 W/kg

SAR(1 g) = 0.745 W/kg; SAR(10 g) = 0.377 W/kg

Maximum value of SAR (measured) = 1.14 W/kg

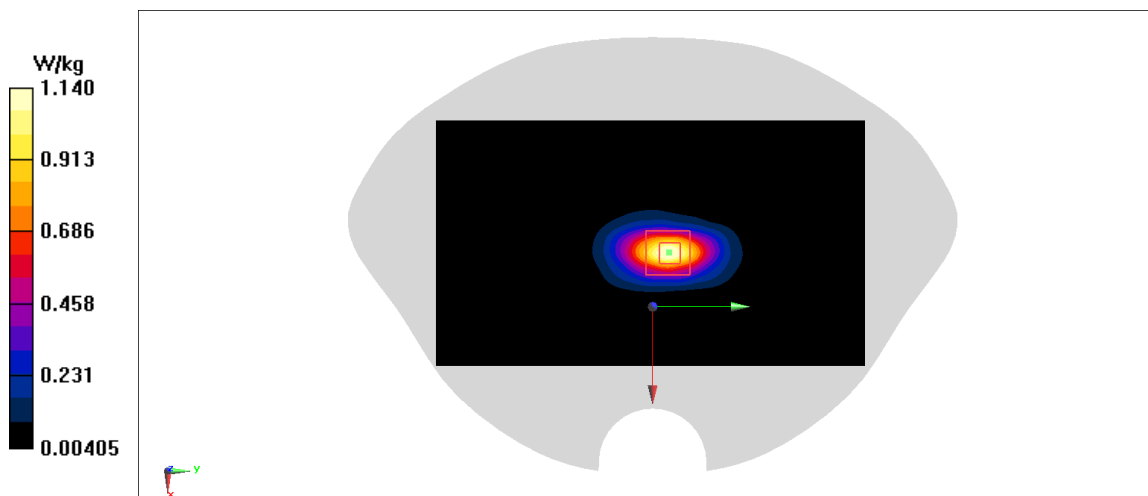

Fig A.28

WCDMA1700-BIV_CH1513 Front

Date: 1/8/2020

Electronics: DAE4 Sn1289

Medium: body 1750 MHz

Medium parameters used: $f = 1752.6$; $\sigma = 1.377$ mho/m; $\epsilon_r = 40.66$; $\rho = 1000$ kg/m³

Ambient Temperature: 22.5°C, Liquid Temperature: 22.3°C

Communication System: WCDMA1700-BIV 1752.6 Duty Cycle: 1: 1

Probe: EX3DV4 – SN3617 ConvF(8.38,8.38,8.38)

Area Scan (71x121x1): Interpolated grid: dx=1.000 mm, dy=1.000 mm

Maximum value of SAR (interpolated) = 1.08 W/kg

Zoom Scan (7x7x7)/Cube 0: Measurement grid: dx=5mm, dy=5mm, dz=5mm

Reference Value = 5.447 V/m; Power Drift = -0.03 dB

Peak SAR (extrapolated) = 1.26 W/kg

SAR(1 g) = 0.739 W/kg; SAR(10 g) = 0.419 W/kg

Maximum value of SAR (measured) = 1.04 W/kg

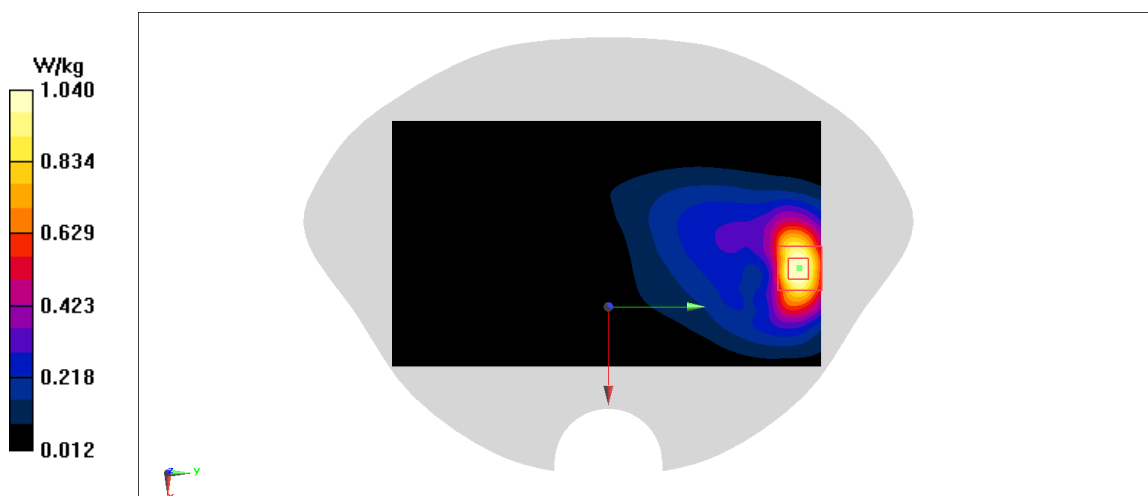

Fig A.29

WCDMA850-BV_CH4233 Left Cheek

Date: 1/7/2020

Electronics: DAE4 Sn1289

Medium: head 835 MHz

Medium parameters used: $f = 846.6$; $\sigma = 0.916$ mho/m; $\epsilon_r = 42.25$; $\rho = 1000$ kg/m³

Ambient Temperature: 22.5°C, Liquid Temperature: 22.3°C

Communication System: WCDMA850-BV 846.6 Duty Cycle: 1:1

Probe: EX3DV4 – SN3617 ConvF(9.75,9.75,9.75)

Area Scan (71x121x1): Interpolated grid: dx=1.000 mm, dy=1.000 mm

Maximum value of SAR (interpolated) = 0.252 W/kg

Zoom Scan (7x7x7)/Cube 0: Measurement grid: dx=5mm, dy=5mm, dz=5mm

Reference Value = 6.165 V/m; Power Drift = 0.04 dB

Peak SAR (extrapolated) = 0.273 W/kg

SAR(1 g) = 0.187 W/kg; SAR(10 g) = 0.143 W/kg

Maximum value of SAR (measured) = 0.219 W/kg

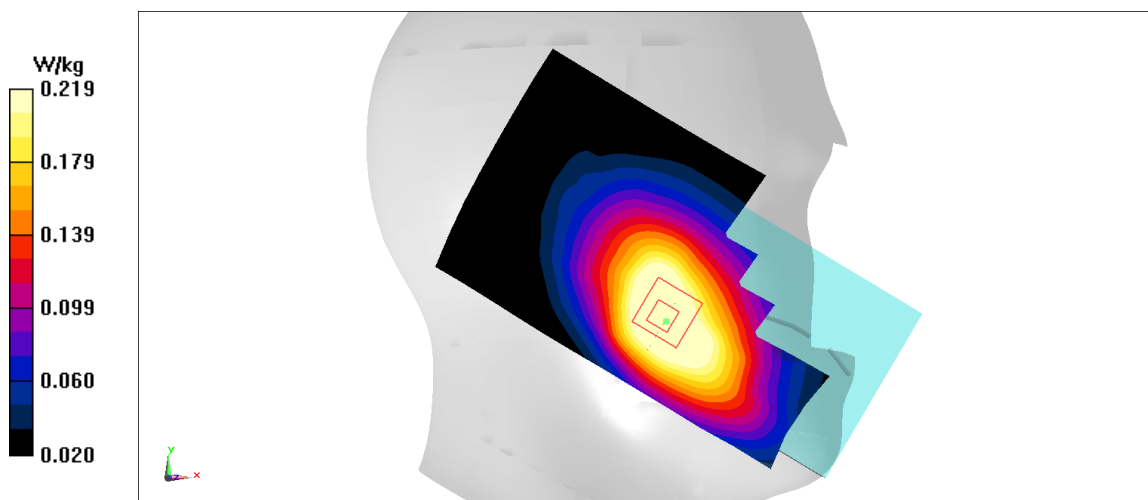

Fig A.30

WCDMA850-BV_CH4183 Rear

Date: 1/7/2020

Electronics: DAE4 Sn1289

Medium: body 835 MHz

Medium parameters used: $f = 836.6$; $\sigma = 0.907$ mho/m; $\epsilon_r = 42.26$; $\rho = 1000$ kg/m³

Ambient Temperature: 22.5°C, Liquid Temperature: 22.3°C

Communication System: WCDMA850-BV 836.6 Duty Cycle: 1:1

Probe: EX3DV4 – SN3617 ConvF(9.75,9.75,9.75)

Area Scan (71x121x1): Interpolated grid: dx=1.000 mm, dy=1.000 mm

Maximum value of SAR (interpolated) = 0.517 W/kg

Zoom Scan (7x7x7)/Cube 0: Measurement grid: dx=5mm, dy=5mm, dz=5mm

Reference Value = 13.69 V/m; Power Drift = 0 dB

Peak SAR (extrapolated) = 0.624 W/kg

SAR(1 g) = 0.366 W/kg; SAR(10 g) = 0.215 W/kg

Maximum value of SAR (measured) = 0.393 W/kg

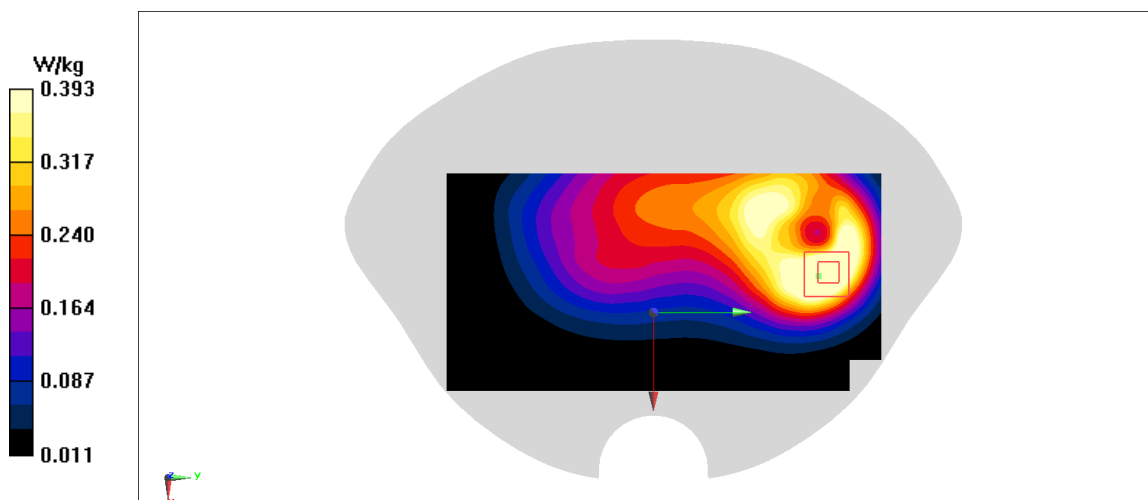

Fig A.31

LTE1900-FDD2_CH19100 Right Cheek

Date: 1/11/2020

Electronics: DAE4 Sn1289

Medium: head 1900 MHz

Medium parameters used: $f = 1900$ MHz; $\sigma = 1.385$ mho/m; $\epsilon_r = 39.78$; $\rho = 1000$ kg/m³

Ambient Temperature: 22.5°C, Liquid Temperature: 22.3°C

Communication System: LTE1900-FDD2 1900 MHz Duty Cycle: 1:1

Probe: EX3DV4 – SN3617 ConvF(8.14,8.14,8.14)

Area Scan (71x121x1): Interpolated grid: dx=1.000 mm, dy=1.000 mm

Maximum value of SAR (interpolated) = 0.149 W/kg

Zoom Scan (7x7x7)/Cube 0: Measurement grid: dx=5mm, dy=5mm, dz=5mm

Reference Value = 4.846 V/m; Power Drift = 0.09 dB

Peak SAR (extrapolated) = 0.161 W/kg

SAR(1 g) = 0.102 W/kg; SAR(10 g) = 0.063 W/kg

Maximum value of SAR (measured) = 0.14 W/kg

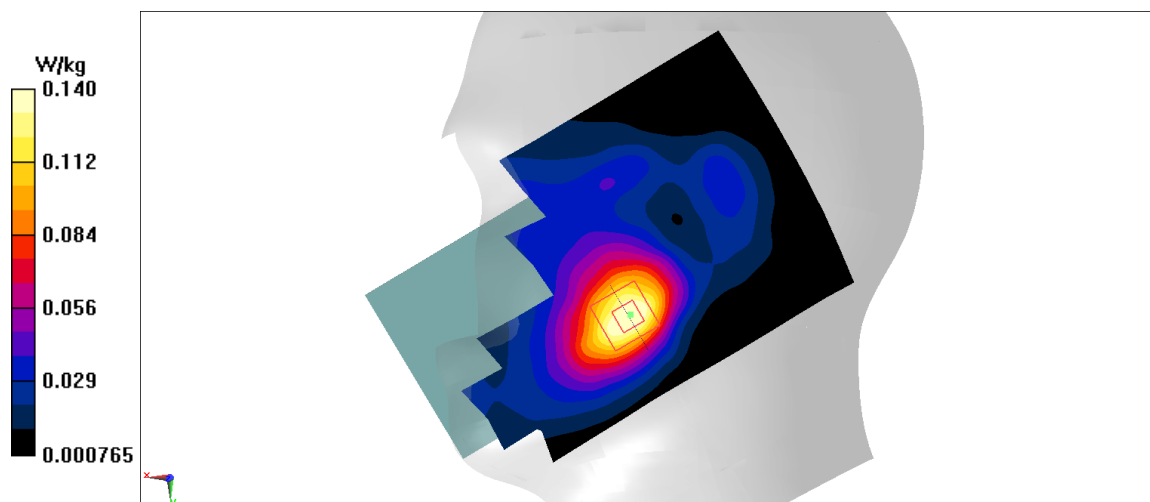

Fig A.32

LTE1900-FDD2_CH19100 Bottom

Date: 1/11/2020

Electronics: DAE4 Sn1289

Medium: body 1900 MHz

Medium parameters used: $f = 1900 \text{ MHz}$; $\sigma = 1.385 \text{ mho/m}$; $\epsilon_r = 39.78$; $\rho = 1000 \text{ kg/m}^3$

Ambient Temperature: 22.5°C , Liquid Temperature: 22.3°C

Communication System: LTE1900-FDD2 1900 MHz Duty Cycle: 1:1

Probe: EX3DV4 – SN3617 ConvF(8.14,8.14,8.14)

Area Scan (71x121x1): Interpolated grid: $dx=1.000 \text{ mm}$, $dy=1.000 \text{ mm}$

Maximum value of SAR (interpolated) = 1.09 W/kg

Zoom Scan (7x7x7)/Cube 0: Measurement grid: $dx=5\text{mm}$, $dy=5\text{mm}$, $dz=5\text{mm}$

Reference Value = 14.46 V/m ; Power Drift = -0.13 dB

Peak SAR (extrapolated) = 1.33 W/kg

SAR(1 g) = 0.697 W/kg ; SAR(10 g) = 0.35 W/kg

Maximum value of SAR (measured) = 1.06 W/kg

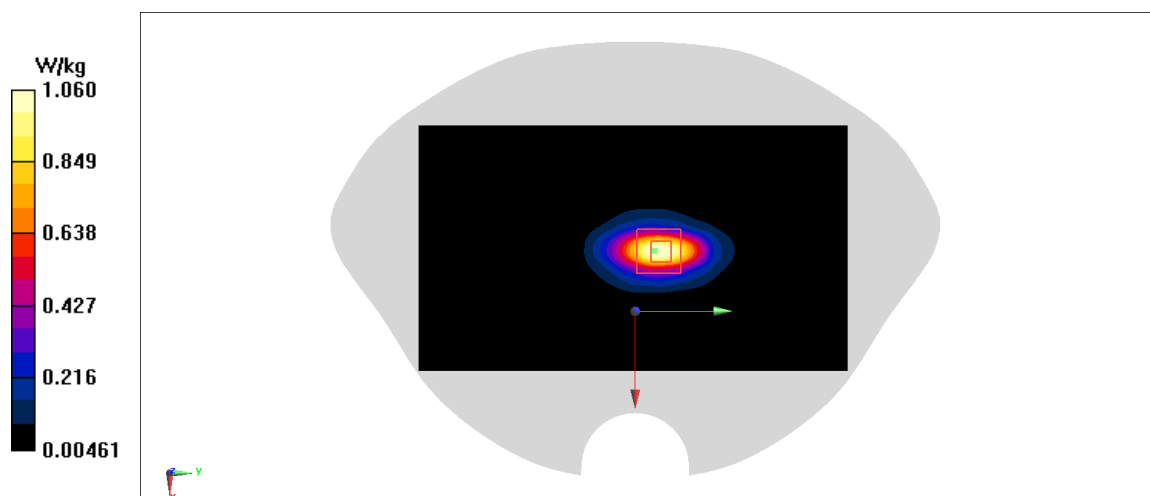

Fig A.33

LTE1900-FDD2_CH19100 Front

Date: 1/11/2020

Electronics: DAE4 Sn1289

Medium: body 1900 MHz

Medium parameters used: $f = 1900$ MHz; $\sigma = 1.385$ mho/m; $\epsilon_r = 39.78$; $\rho = 1000$ kg/m³

Ambient Temperature: 22.5°C, Liquid Temperature: 22.3°C

Communication System: LTE1900-FDD2 1900 MHz Duty Cycle: 1:1

Probe: EX3DV4 – SN3617 ConvF(8.14,8.14,8.14)

Area Scan (71x121x1): Interpolated grid: dx=1.000 mm, dy=1.000 mm

Maximum value of SAR (interpolated) = 0.874 W/kg

Zoom Scan (7x7x7)/Cube 0: Measurement grid: dx=5mm, dy=5mm, dz=5mm

Reference Value = 8.651 V/m; Power Drift = -0.09 dB

Peak SAR (extrapolated) = 1.09 W/kg

SAR(1 g) = 0.628 W/kg; SAR(10 g) = 0.347 W/kg

Maximum value of SAR (measured) = 0.882 W/kg

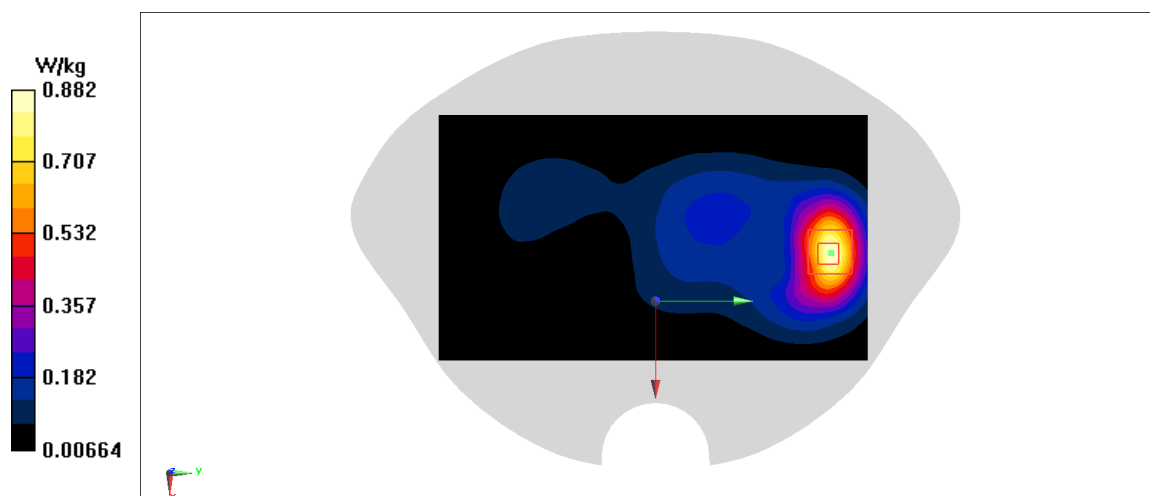

Fig A.34

LTE1700-FDD4_CH20300 Right Cheek

Date: 1/9/2020

Electronics: DAE4 Sn1289

Medium: head 1750 MHz

Medium parameters used: $f = 1745$ MHz; $\sigma = 1.392$ mho/m; $\epsilon_r = 40.08$; $\rho = 1000$ kg/m³

Ambient Temperature: 22.5°C, Liquid Temperature: 22.3°C

Communication System: LTE1700-FDD4 1745 MHz Duty Cycle: 1:1

Probe: EX3DV4 – SN3617 ConvF(8.38,8.38,8.38)

Area Scan (71x121x1): Interpolated grid: dx=1.000 mm, dy=1.000 mm

Maximum value of SAR (interpolated) = 0.128 W/kg

Zoom Scan (7x7x7)/Cube 0: Measurement grid: dx=5mm, dy=5mm, dz=5mm

Reference Value = 4.8 V/m; Power Drift = -0.05 dB

Peak SAR (extrapolated) = 0.137 W/kg

SAR(1 g) = 0.089 W/kg; SAR(10 g) = 0.056 W/kg

Maximum value of SAR (measured) = 0.12 W/kg

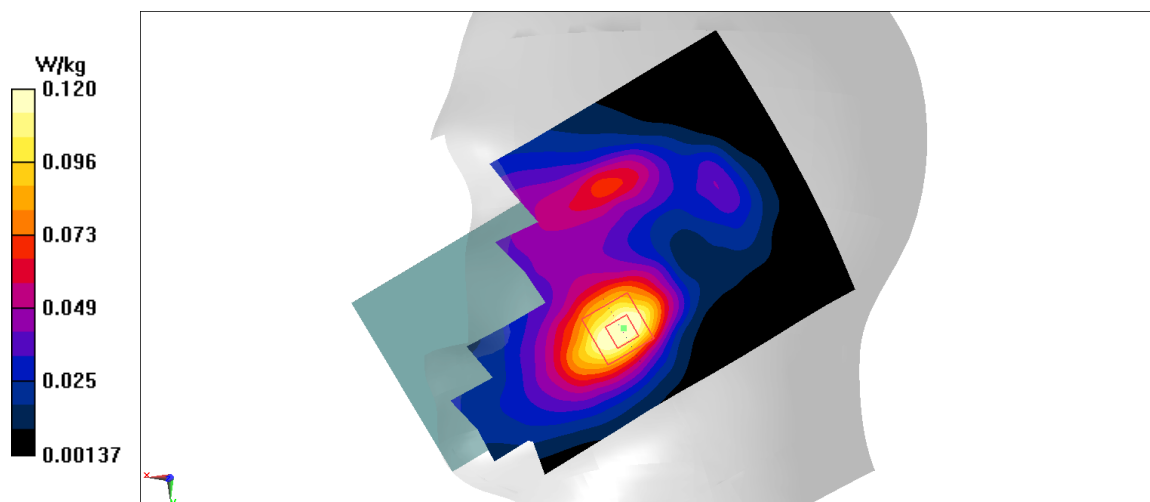

Fig A.35

LTE1700-FDD4_CH20300 Bottom

Date: 1/9/2020

Electronics: DAE4 Sn1289

Medium: body 1750 MHz

Medium parameters used: $f = 1745 \text{ MHz}$; $\sigma = 1.392 \text{ mho/m}$; $\epsilon_r = 40.08$; $\rho = 1000 \text{ kg/m}^3$

Ambient Temperature: 22.5°C , Liquid Temperature: 22.3°C

Communication System: LTE1700-FDD4 1745 MHz Duty Cycle: 1:1

Probe: EX3DV4 – SN3617 ConvF(8.38,8.38,8.38)

Area Scan (71x121x1): Interpolated grid: $dx=1.000 \text{ mm}$, $dy=1.000 \text{ mm}$

Maximum value of SAR (interpolated) = 1.08 W/kg

Zoom Scan (7x7x7)/Cube 0: Measurement grid: $dx=5\text{mm}$, $dy=5\text{mm}$, $dz=5\text{mm}$

Reference Value = 14.66 V/m ; Power Drift = 0.02 dB

Peak SAR (extrapolated) = 1.31 W/kg

SAR(1 g) = 0.697 W/kg ; SAR(10 g) = 0.354 W/kg

Maximum value of SAR (measured) = 1.05 W/kg

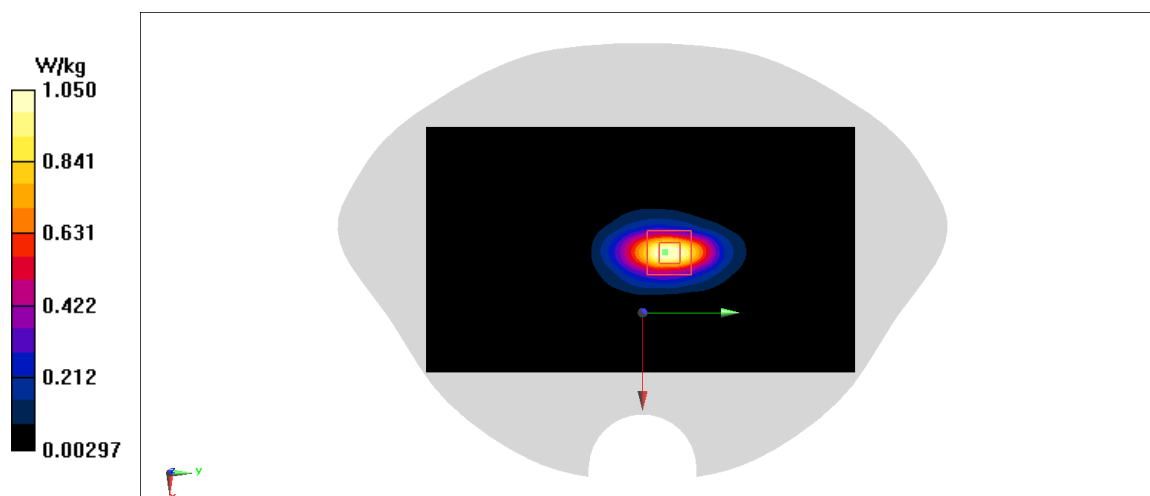

Fig A.36

LTE1700-FDD4_CH20300 Front

Date: 1/9/2020

Electronics: DAE4 Sn1289

Medium: body 1750 MHz

Medium parameters used: $f = 1745$ MHz; $\sigma = 1.392$ mho/m; $\epsilon_r = 40.08$; $\rho = 1000$ kg/m³

Ambient Temperature: 22.5°C, Liquid Temperature: 22.3°C

Communication System: LTE1700-FDD4 1745 MHz Duty Cycle: 1:1

Probe: EX3DV4 – SN3617 ConvF(8.38,8.38,8.38)

Area Scan (71x121x1): Interpolated grid: dx=1.000 mm, dy=1.000 mm

Maximum value of SAR (interpolated) = 0.711 W/kg

Zoom Scan (7x7x7)/Cube 0: Measurement grid: dx=5mm, dy=5mm, dz=5mm

Reference Value = 5.508 V/m; Power Drift = 0.03 dB

Peak SAR (extrapolated) = 0.912 W/kg

SAR(1 g) = 0.528 W/kg; SAR(10 g) = 0.296 W/kg

Maximum value of SAR (measured) = 0.718 W/kg

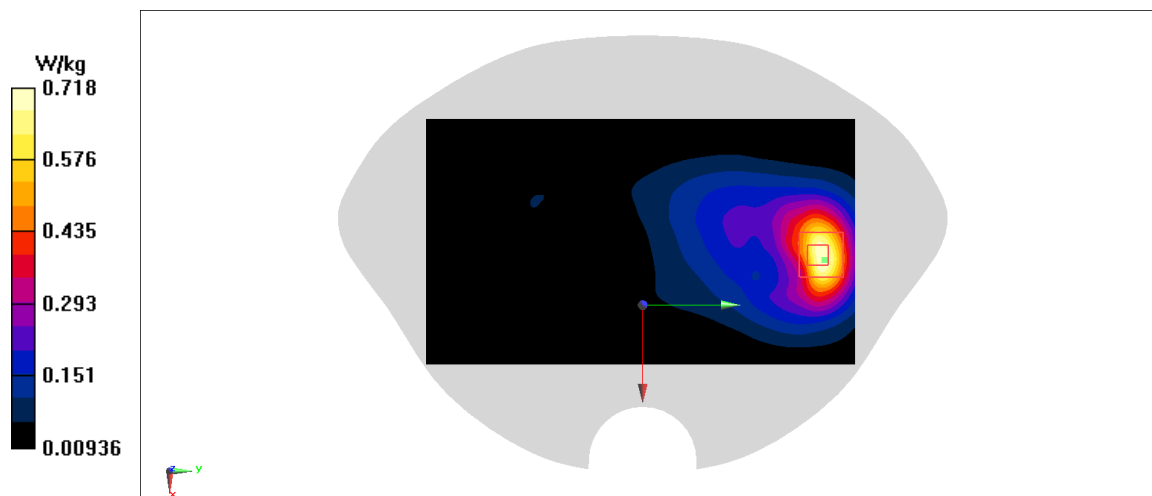

Fig A.37

LTE850-FDD5_CH20450 Left Cheek

Date: 1/6/2020

Electronics: DAE4 Sn1289

Medium: head 835 MHz

Medium parameters used: $f = 829$ MHz; $\sigma = 0.886$ mho/m; $\epsilon_r = 41.35$; $\rho = 1000$ kg/m³

Ambient Temperature: 22.5°C, Liquid Temperature: 22.3°C

Communication System: LTE850-FDD5 829 MHz Duty Cycle: 1: 1

Probe: EX3DV4 – SN3617 ConvF(9.75,9.75,9.75)

Area Scan (71x121x1): Interpolated grid: dx=1.000 mm, dy=1.000 mm

Maximum value of SAR (interpolated) = 0.218 W/kg

Zoom Scan (7x7x7)/Cube 0: Measurement grid: dx=5mm, dy=5mm, dz=5mm

Reference Value = 6.023 V/m; Power Drift = 0.09 dB

Peak SAR (extrapolated) = 0.236 W/kg

SAR(1 g) = 0.18 W/kg; SAR(10 g) = 0.138 W/kg

Maximum value of SAR (measured) = 0.216 W/kg

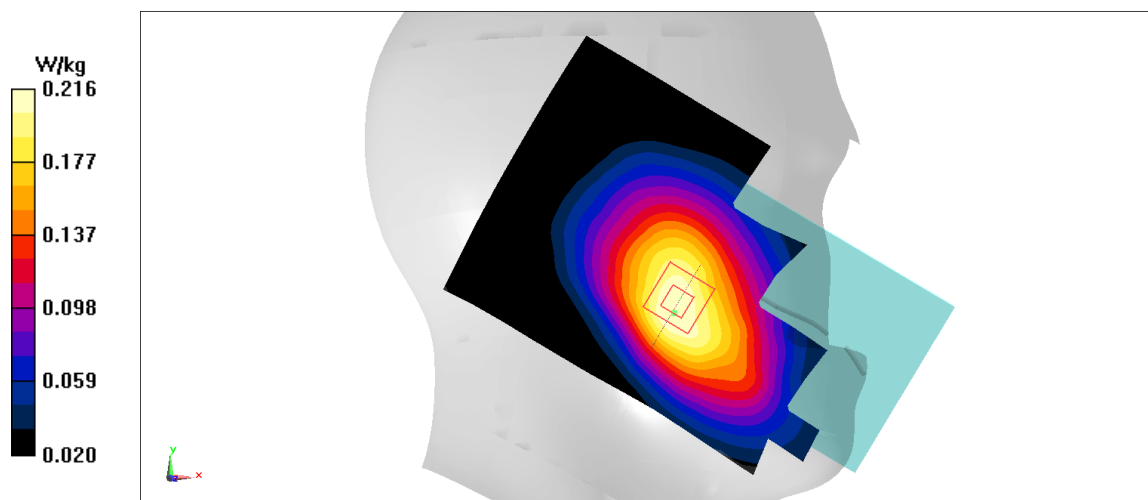

Fig A.38

LTE850-FDD5_CH20450 Front

Date: 1/6/2020

Electronics: DAE4 Sn1289

Medium: body 835 MHz

Medium parameters used: $f = 829 \text{ MHz}$; $\sigma = 0.886 \text{ mho/m}$; $\epsilon_r = 41.35$; $\rho = 1000 \text{ kg/m}^3$

Ambient Temperature: 22.5°C , Liquid Temperature: 22.3°C

Communication System: LTE850-FDD5 829 MHz Duty Cycle: 1: 1

Probe: EX3DV4 – SN3617 ConvF(9.75,9.75,9.75)

Area Scan (71x121x1): Interpolated grid: $dx=1.000 \text{ mm}$, $dy=1.000 \text{ mm}$

Maximum value of SAR (interpolated) = 0.366 W/kg

Zoom Scan (7x7x7)/Cube 0: Measurement grid: $dx=5\text{mm}$, $dy=5\text{mm}$, $dz=5\text{mm}$

Reference Value = 12.2 V/m ; Power Drift = -0.12 dB

Peak SAR (extrapolated) = 0.518 W/kg

SAR(1 g) = 0.302 W/kg ; SAR(10 g) = 0.182 W/kg

Maximum value of SAR (measured) = 0.435 W/kg

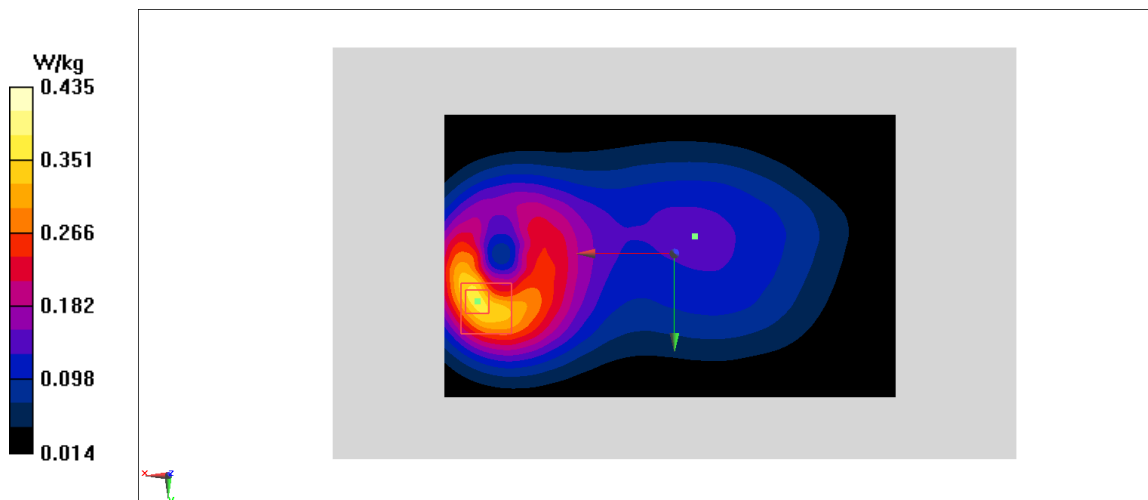

Fig A.39

LTE2500-FDD7_CH21100 Right Cheek

Date: 1/15/2020

Electronics: DAE4 Sn1289

Medium: head 2600 MHz

Medium parameters used: $f = 2535$ MHz; $\sigma = 1.916$ mho/m; $\epsilon_r = 38.87$; $\rho = 1000$ kg/m³

Ambient Temperature: 22.5°C, Liquid Temperature: 22.3°C

Communication System: LTE2500-FDD7 2535 MHz Duty Cycle: 1:1

Probe: EX3DV4 – SN3617 ConvF(7.19,7.19,7.19)

Area Scan (71x121x1): Interpolated grid: dx=1.000 mm, dy=1.000 mm

Maximum value of SAR (interpolated) = 0.152 W/kg

Zoom Scan (7x7x7)/Cube 0: Measurement grid: dx=5mm, dy=5mm, dz=5mm

Reference Value = 1.831 V/m; Power Drift = 0.04 dB

Peak SAR (extrapolated) = 0.17 W/kg

SAR(1 g) = 0.103 W/kg; SAR(10 g) = 0.058 W/kg

Maximum value of SAR (measured) = 0.138 W/kg

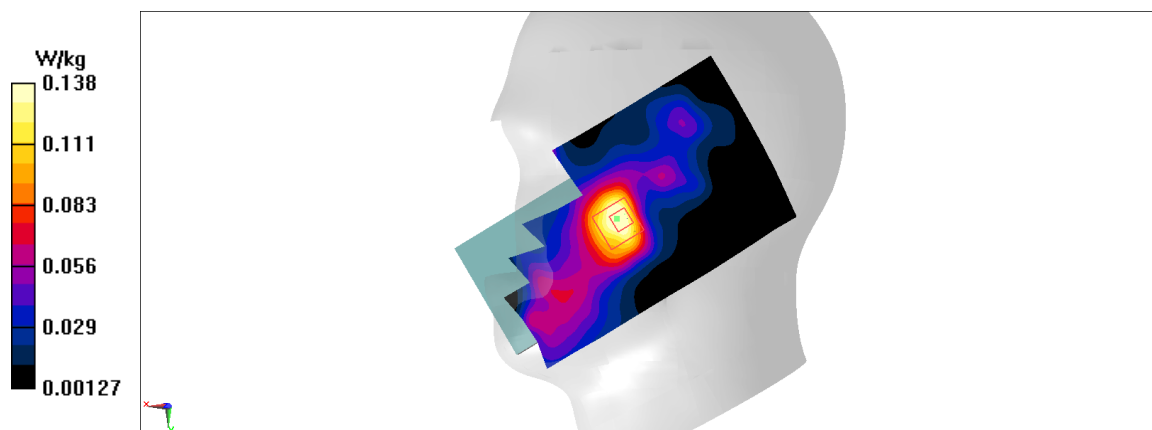
**Fig A.40**

LTE2500-FDD7_CH21100 Bottom

Date: 1/15/2020

Electronics: DAE4 Sn1289

Medium: body 2600 MHz

Medium parameters used: $f = 2535$ MHz; $\sigma = 1.916$ mho/m; $\epsilon_r = 38.87$; $\rho = 1000$ kg/m³

Ambient Temperature: 22.5°C, Liquid Temperature: 22.3°C

Communication System: LTE2500-FDD7 2535 MHz Duty Cycle: 1:1

Probe: EX3DV4 – SN3617 ConvF(7.19,7.19,7.19)

Area Scan (71x121x1): Interpolated grid: dx=1.000 mm, dy=1.000 mm

Maximum value of SAR (interpolated) = 1.01 W/kg

Zoom Scan (7x7x7)/Cube 0: Measurement grid: dx=5mm, dy=5mm, dz=5mm

Reference Value = 3.961 V/m; Power Drift = 0.02 dB

Peak SAR (extrapolated) = 1.26 W/kg

SAR(1 g) = 0.626 W/kg; SAR(10 g) = 0.289 W/kg

Maximum value of SAR (measured) = 0.978 W/kg

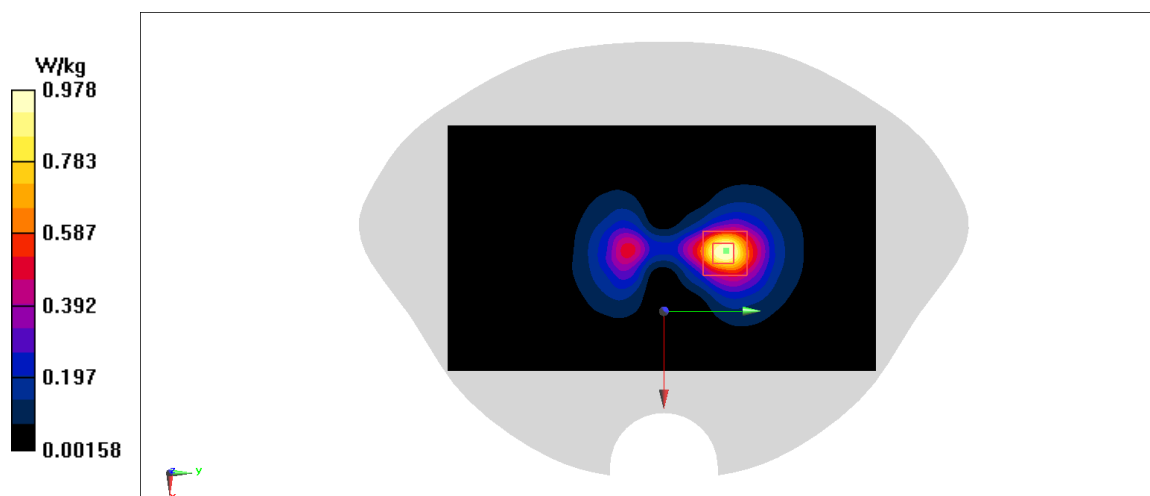

Fig A.41

LTE2500-FDD7_CH21100 Rear

Date: 1/15/2020

Electronics: DAE4 Sn1289

Medium: body 2600 MHz

Medium parameters used: $f = 2535$ MHz; $\sigma = 1.916$ mho/m; $\epsilon_r = 38.87$; $\rho = 1000$ kg/m³

Ambient Temperature: 22.5°C, Liquid Temperature: 22.3°C

Communication System: LTE2500-FDD7 2535 MHz Duty Cycle: 1:1

Probe: EX3DV4 – SN3617 ConvF(7.19,7.19,7.19)

Area Scan (71x121x1): Interpolated grid: dx=1.000 mm, dy=1.000 mm

Maximum value of SAR (interpolated) = 0.714 W/kg

Zoom Scan (7x7x7)/Cube 0: Measurement grid: dx=5mm, dy=5mm, dz=5mm

Reference Value = 6.771 V/m; Power Drift = -0.07 dB

Peak SAR (extrapolated) = 0.958 W/kg

SAR(1 g) = 0.484 W/kg; SAR(10 g) = 0.24 W/kg

Maximum value of SAR (measured) = 0.758 W/kg

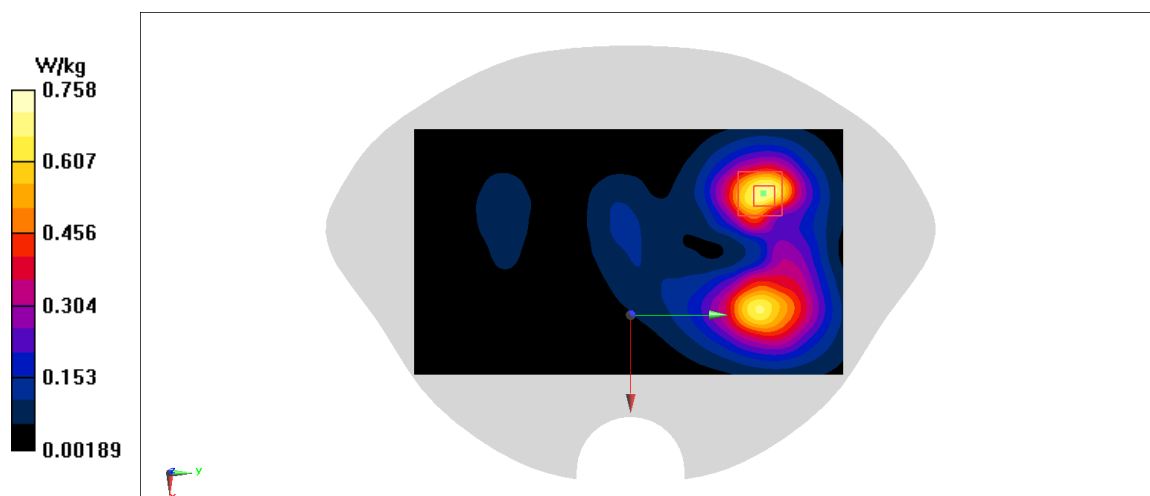
**Fig A.42**

LTE2600-TDD38_CH38150 Right Cheek

Date: 1/14/2020

Electronics: DAE4 Sn1289

Medium: head 2600 MHz

Medium parameters used: $f = 2610$ MHz; $\sigma = 1.947$ mho/m; $\epsilon_r = 39.11$; $\rho = 1000$ kg/m³

Ambient Temperature: 22.5°C, Liquid Temperature: 22.3°C

Communication System: LTE2600-TDD38 2610 MHz Duty Cycle: 1:1

Probe: EX3DV4 – SN3617 ConvF(7.19,7.19,7.19)

Area Scan (71x121x1): Interpolated grid: dx=1.000 mm, dy=1.000 mm

Maximum value of SAR (interpolated) = 0.1 W/kg

Zoom Scan (7x7x7)/Cube 0: Measurement grid: dx=5mm, dy=5mm, dz=5mm

Reference Value = 1.353 V/m; Power Drift = -0.02 dB

Peak SAR (extrapolated) = 0.091 W/kg

SAR(1 g) = 0.056 W/kg; SAR(10 g) = 0.033 W/kg

Maximum value of SAR (measured) = 0.0767 W/kg

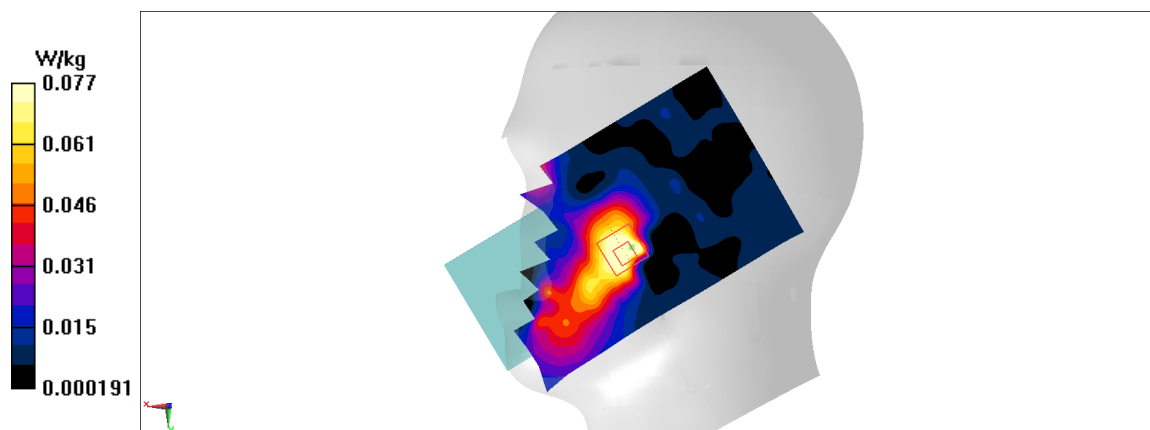

Fig A.43

LTE2600-TDD38_CH38150 Bottom

Date: 1/14/2020

Electronics: DAE4 Sn1289

Medium: head 2600 MHz

Medium parameters used: $f = 2610$ MHz; $\sigma = 1.947$ mho/m; $\epsilon_r = 39.11$; $\rho = 1000$ kg/m³

Ambient Temperature: 22.5°C, Liquid Temperature: 22.3°C

Communication System: LTE2600-TDD38 2610 MHz Duty Cycle: 1:1

Probe: EX3DV4 – SN3617 ConvF(7.49,7.49,7.49)

Area Scan (71x121x1): Interpolated grid: dx=1.000 mm, dy=1.000 mm

Maximum value of SAR (interpolated) = 0.696 W/kg

Zoom Scan (7x7x7)/Cube 0: Measurement grid: dx=5mm, dy=5mm, dz=5mm

Reference Value = 9.309 V/m; Power Drift = 0.05 dB

Peak SAR (extrapolated) = 1.05 W/kg

SAR(1 g) = 0.484 W/kg; SAR(10 g) = 0.215 W/kg

Maximum value of SAR (measured) = 0.81 W/kg

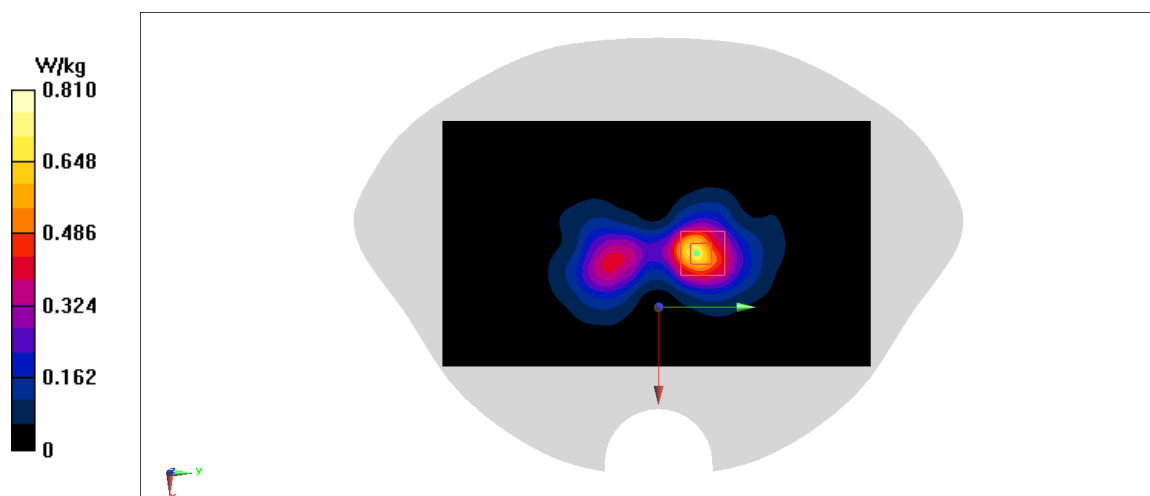

Fig A.44

LTE2600-TDD38_CH38150 Front

Date: 1/14/2020

Electronics: DAE4 Sn1289

Medium: head 2600 MHz

Medium parameters used: $f = 2610$ MHz; $\sigma = 1.947$ mho/m; $\epsilon_r = 39.11$; $\rho = 1000$ kg/m³

Ambient Temperature: 22.5°C, Liquid Temperature: 22.3°C

Communication System: LTE2600-TDD38 2610 MHz Duty Cycle: 1:1

Probe: EX3DV4 – SN3617 ConvF(7.49,7.49,7.49)

Area Scan (71x121x1): Interpolated grid: dx=1.000 mm, dy=1.000 mm

Maximum value of SAR (interpolated) = 0.367 W/kg

Zoom Scan (7x7x7)/Cube 0: Measurement grid: dx=5mm, dy=5mm, dz=5mm

Reference Value = 4.288 V/m; Power Drift = -0.07 dB

Peak SAR (extrapolated) = 0.48 W/kg

SAR(1 g) = 0.233 W/kg; SAR(10 g) = 0.115 W/kg

Maximum value of SAR (measured) = 0.367 W/kg

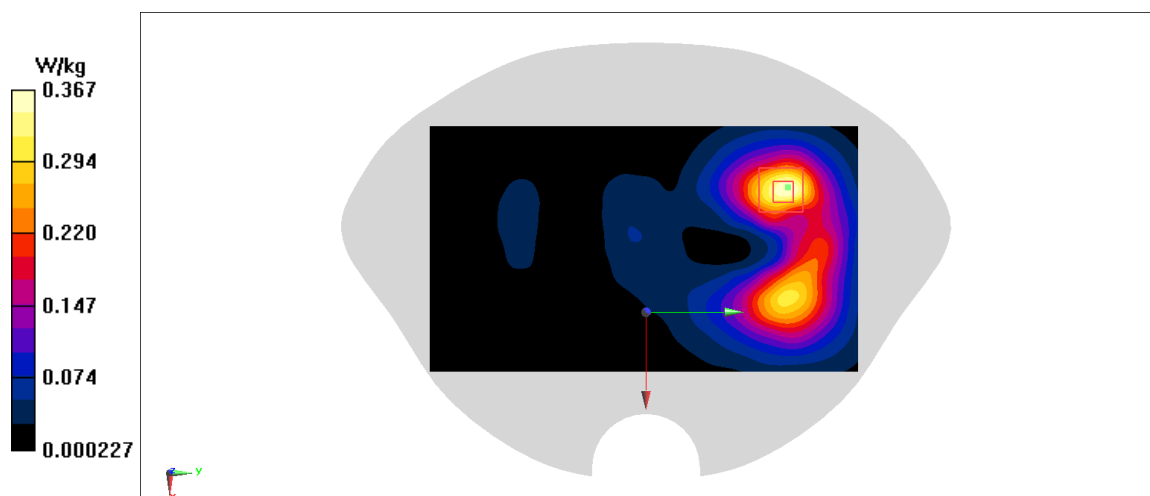

Fig A.45

WLAN2450_CH6 Right Tilt

Date: 1/12/2020

Electronics: DAE4 Sn1289

Medium: head 2450 MHz

Medium parameters used: $f = 2437$; $\sigma = 1.765$ mho/m; $\epsilon_r = 38.45$; $\rho = 1000$ kg/m³

Ambient Temperature: 22.5°C, Liquid Temperature: 22.3°C

Communication System: WLAN2450 2437 Duty Cycle: 1:1

Probe: EX3DV4 – SN3617 ConvF(7.62,7.62,7.62)

Area Scan (71x121x1): Interpolated grid: dx=1.000 mm, dy=1.000 mm

Maximum value of SAR (interpolated) = 1.1 W/kg

Zoom Scan (7x7x7)/Cube 0: Measurement grid: dx=5mm, dy=5mm, dz=5mm

Reference Value = 15.16 V/m; Power Drift = -0.05 dB

Peak SAR (extrapolated) = 1.6 W/kg

SAR(1 g) = 0.611 W/kg; SAR(10 g) = 0.248 W/kg

Maximum value of SAR (measured) = 1.19 W/kg

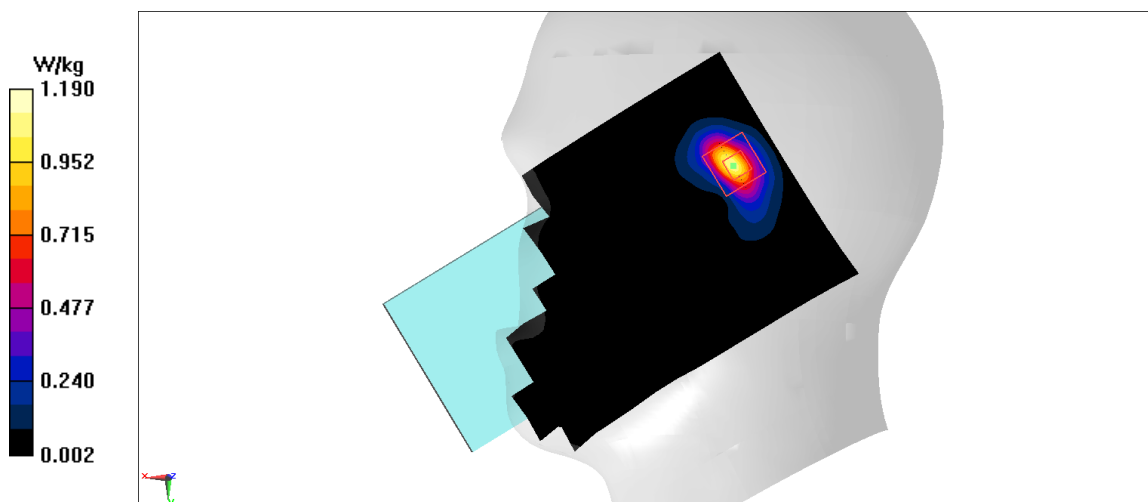

Fig A.46

WLAN2450_CH11 Top

Date: 1/13/2020

Electronics: DAE4 Sn1289

Medium: head 2450 MHz

Medium parameters used: $f = 2462$; $\sigma = 1.788$ mho/m; $\epsilon_r = 39.12$; $\rho = 1000$ kg/m³

Ambient Temperature: 22.5°C, Liquid Temperature: 22.3°C

Communication System: WLAN2450 2462 Duty Cycle: 1:1

Probe: EX3DV4 – SN3617 ConvF(7.79,7.79,7.79)

Area Scan (71x121x1): Interpolated grid: dx=1.000 mm, dy=1.000 mm

Maximum value of SAR (interpolated) = 1.39 W/kg

Zoom Scan (7x7x7)/Cube 0: Measurement grid: dx=5mm, dy=5mm, dz=5mm

Reference Value = 11.38 V/m; Power Drift = -0.03 dB

Peak SAR (extrapolated) = 1.92 W/kg

SAR(1 g) = 0.913 W/kg; SAR(10 g) = 0.431 W/kg

Maximum value of SAR (measured) = 1.51 W/kg

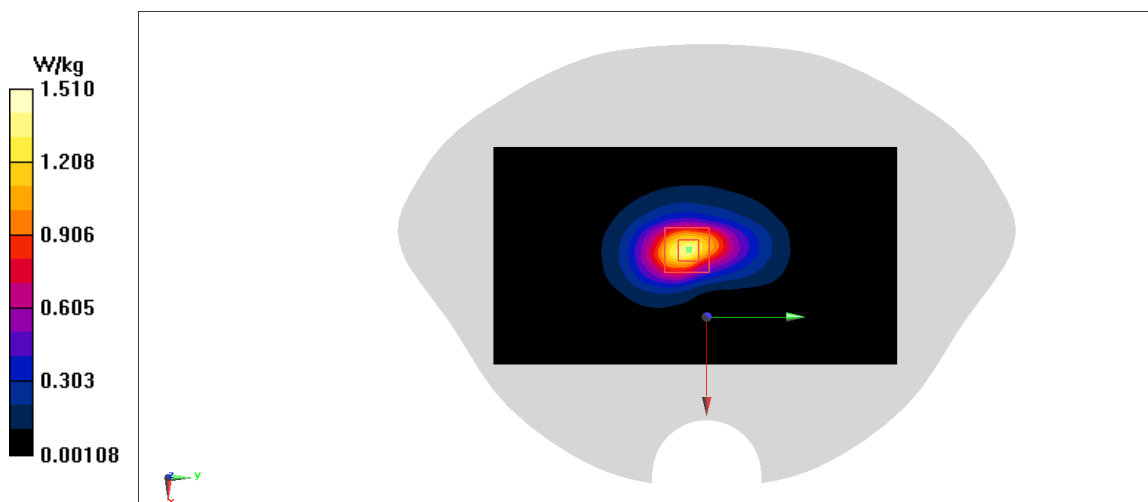

Fig A.47

WLAN5G_CH157 Left Tilt

Date: 1/18/2020

Electronics: DAE4 Sn1289

Medium: head 5 GHz

Medium parameters used: $f = 5785$; $\sigma = 5.24$ mho/m; $\epsilon_r = 35.33$; $\rho = 1000$ kg/m³

Ambient Temperature: 22.5°C, Liquid Temperature: 22.3°C

Communication System: WLAN5G 5785 Duty Cycle: 1:1

Probe: EX3DV4 – SN3617 ConvF(5.07,5.07,5.07)

Area Scan (71x121x1): Interpolated grid: dx=1.000 mm, dy=1.000 mm

Maximum value of SAR (interpolated) = 4.28 W/kg

Zoom Scan (7x7x7)/Cube 0: Measurement grid: dx=5mm, dy=5mm, dz=5mm

Reference Value = 27.73 V/m; Power Drift = 0.09 dB

Peak SAR (extrapolated) = 5.18 W/kg

SAR(1 g) = 0.972 W/kg; SAR(10 g) = 0.252 W/kg

Maximum value of SAR (measured) = 3.09 W/kg

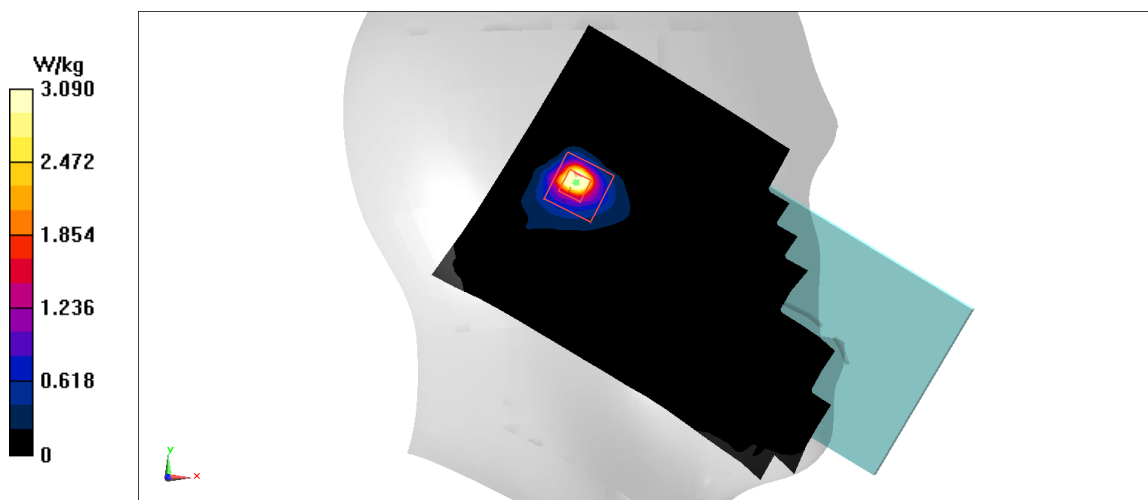

Fig A.48

WLAN5G_CH48 Rear

Date: 1/16/2020

Electronics: DAE4 Sn1289

Medium: head 5 GHz

Medium parameters used: $f = 5240$; $\sigma = 4.736$ mho/m; $\epsilon_r = 35.38$; $\rho = 1000$ kg/m³

Ambient Temperature: 22.5°C, Liquid Temperature: 22.3°C

Communication System: WLAN5G 5240 Duty Cycle: 1:1

Probe: EX3DV4 – SN3617 ConvF(5.39,5.39,5.39)

Area Scan (71x121x1): Interpolated grid: dx=1.000 mm, dy=1.000 mm

Maximum value of SAR (interpolated) = 0.875 W/kg

Zoom Scan (7x7x7)/Cube 0: Measurement grid: dx=5mm, dy=5mm, dz=5mm

Reference Value = 2.614 V/m; Power Drift = 0.02 dB

Peak SAR (extrapolated) = 1.26 W/kg

SAR(1 g) = 0.312 W/kg; SAR(10 g) = 0.09 W/kg

Maximum value of SAR (measured) = 0.775 W/kg

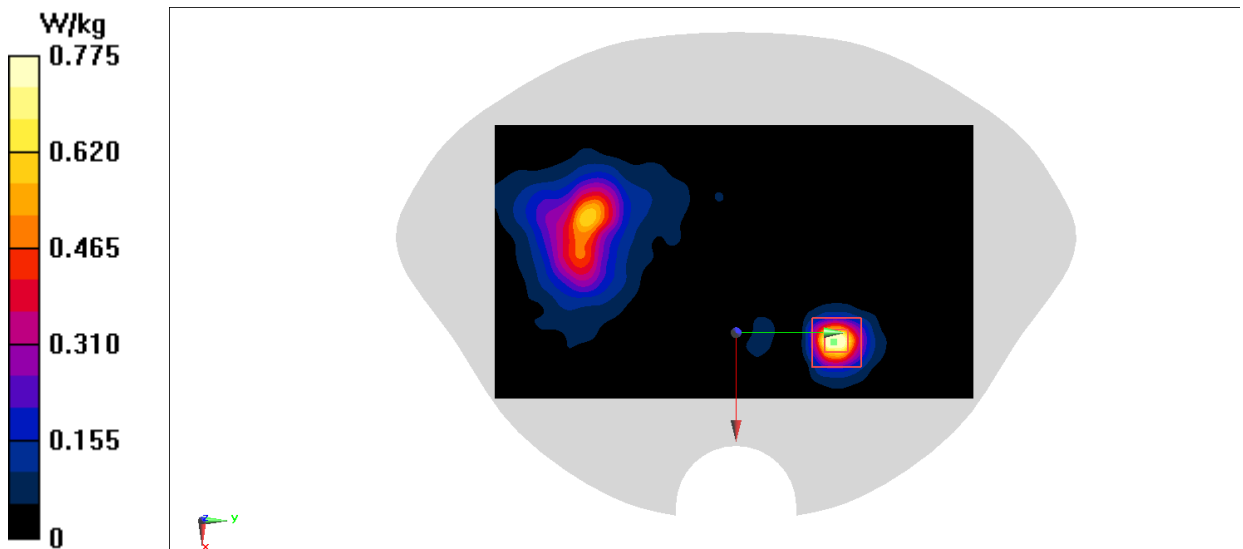

Fig A.49

BT_CH0 Right Tilt

Date: 1/9/2020

Electronics: DAE4 Sn1289

Medium: head 2450 MHz

Medium parameters used: $f = 2402$; $\sigma = 1.777$ mho/m; $\epsilon_r = 38.43$; $\rho = 1000$ kg/m³

Ambient Temperature: 22.5°C, Liquid Temperature: 22.3°C

Communication System: BT Duty Cycle: 1:1

Probe: EX3DV4 – SN3617 ConvF(7.62,7.62,7.62)

Area Scan (71x121x1): Interpolated grid: dx=1.000 mm, dy=1.000 mm

Maximum value of SAR (interpolated) = 1.05 W/kg

Zoom Scan (7x7x7)/Cube 0: Measurement grid: dx=5mm, dy=5mm, dz=5mm

Reference Value = 9.287 V/m; Power Drift = 0.03 dB

Peak SAR (extrapolated) = 1.48 W/kg

SAR(1 g) = 0.611 W/kg; SAR(10 g) = 0.259 W/kg

Maximum value of SAR (measured) = 1.15 W/kg

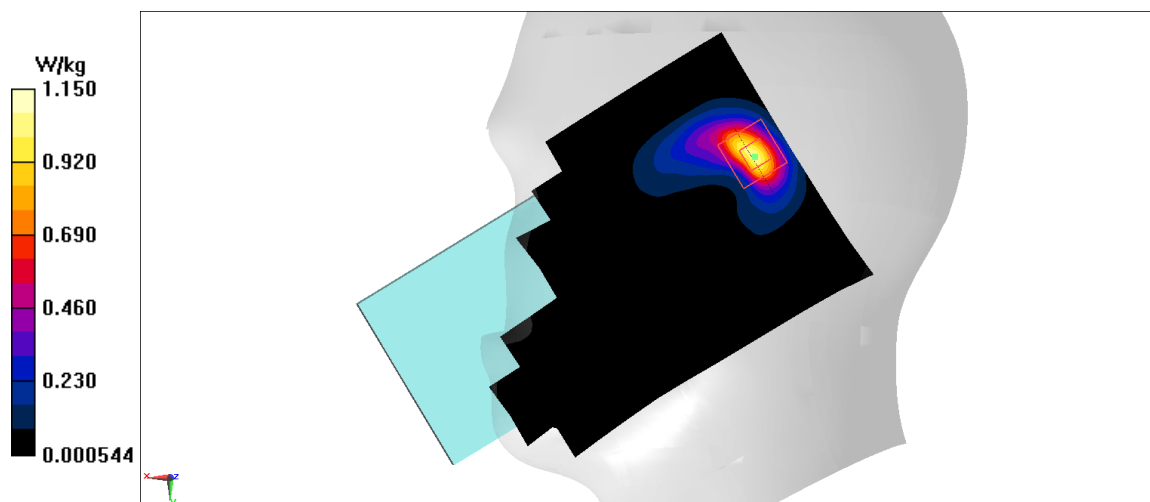

Fig A.50

BT_CH0 Top

Date: 1/9/2020

Electronics: DAE4 Sn1289

Medium: head 2450 MHz

Medium parameters used: $f = 2402$; $\sigma = 1.777$ mho/m; $\epsilon_r = 38.43$; $\rho = 1000$ kg/m³

Ambient Temperature: 22.5°C, Liquid Temperature: 22.3°C

Communication System: BT Duty Cycle: 1:1

Probe: EX3DV4 – SN3617 ConvF(7.79,7.79,7.79)

Area Scan (71x121x1): Interpolated grid: dx=1.000 mm, dy=1.000 mm

Maximum value of SAR (interpolated) = 0.405 W/kg

Zoom Scan (7x7x7)/Cube 0: Measurement grid: dx=5mm, dy=5mm, dz=5mm

Reference Value = 7.966 V/m; Power Drift = 0.017 dB

Peak SAR (extrapolated) = 0.617 W/kg

SAR(1 g) = 0.304 W/kg; SAR(10 g) = 0.145 W/kg

Maximum value of SAR (measured) = 0.495 W/kg

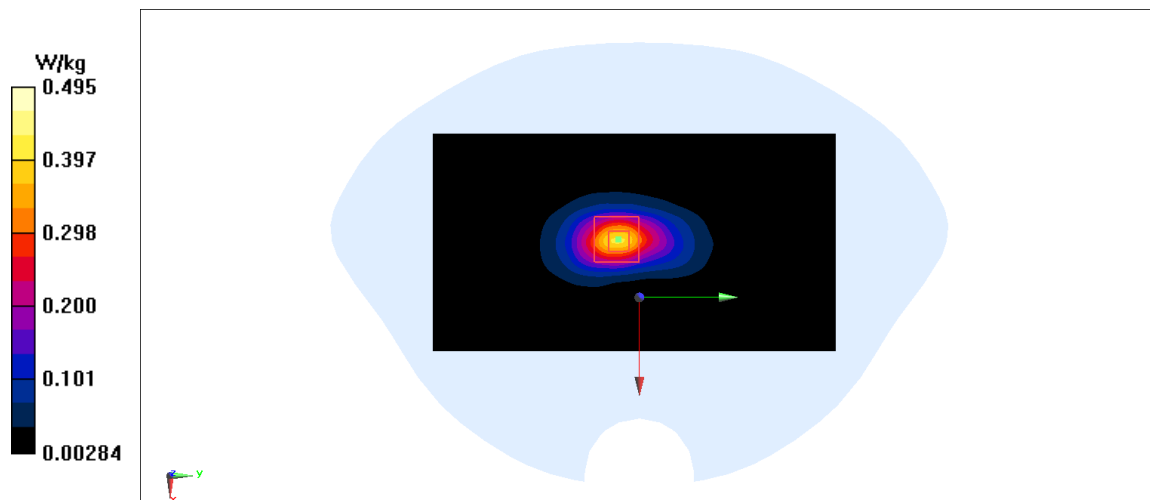

Fig A.51

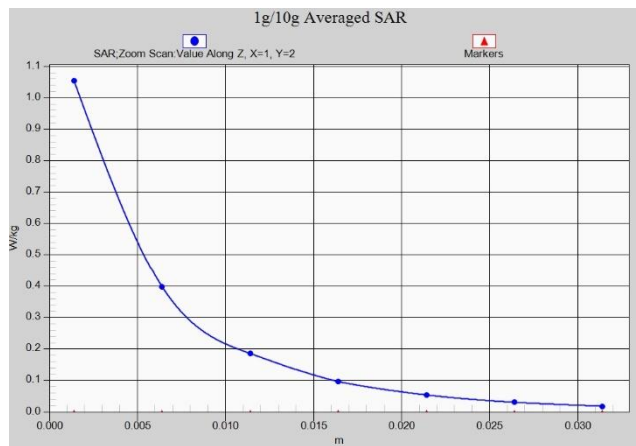

Fig. 1-1 Z-Scan at power reference point (GSM850)

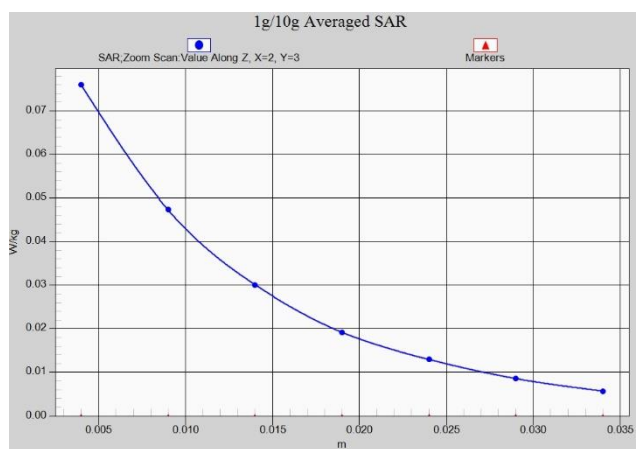

Fig. 1-2 Z-Scan at power reference point (GSM850)

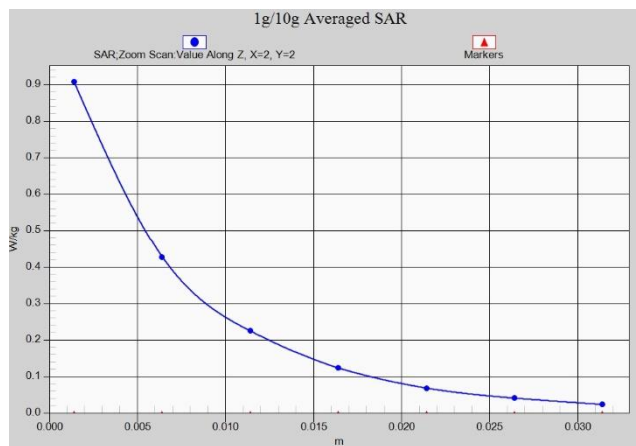

Fig. 1-3 Z-Scan at power reference point (PCS1900)

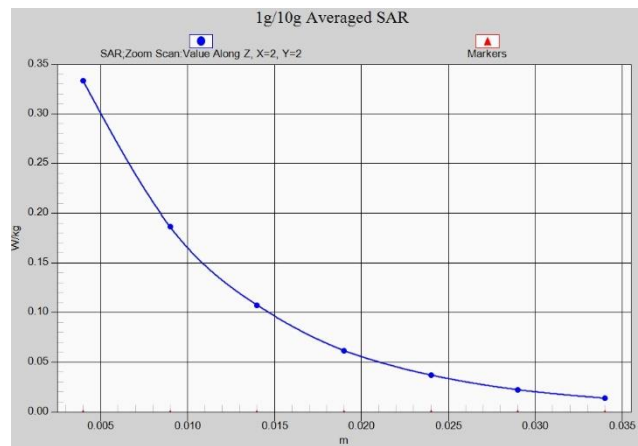

Fig. 1-4 Z-Scan at power reference point (PCS1900)

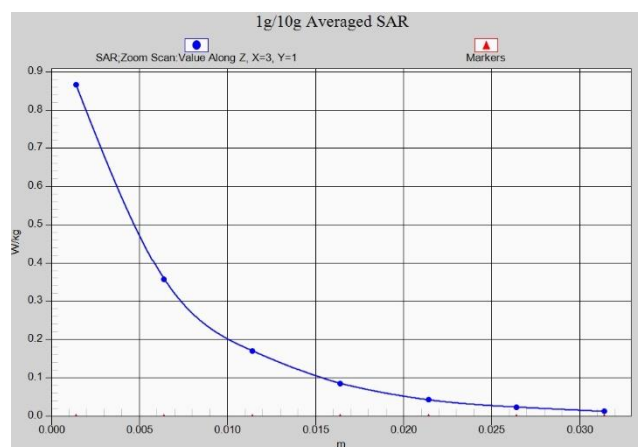

Fig. 1-5 Z-Scan at power reference point (WCDMA1900)

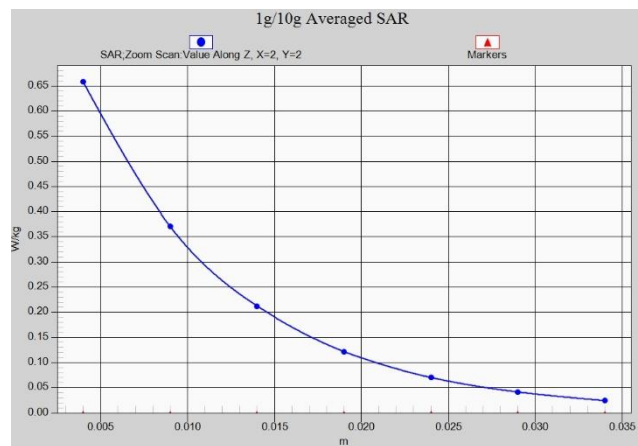

Fig. 1-6 Z-Scan at power reference point (WCDMA1900)

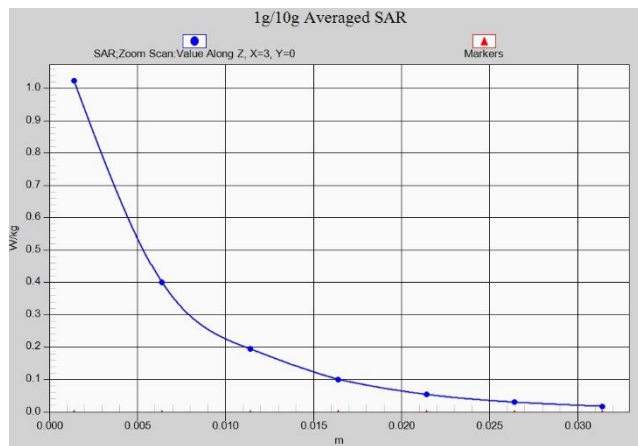

Fig. 1-7 Z-Scan at power reference point (WCDMA1700)

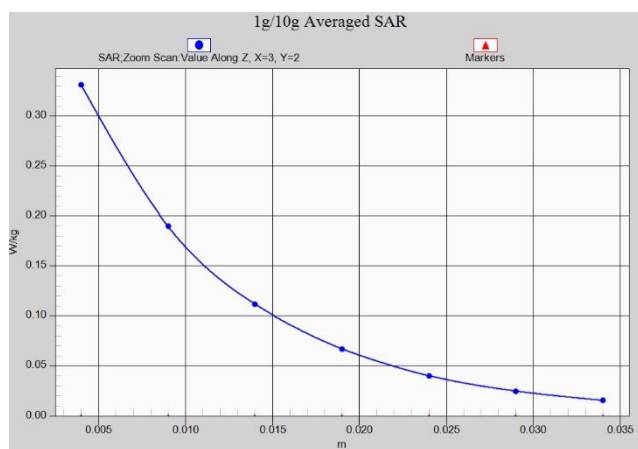

Fig. 1-8 Z-Scan at power reference point (WCDMA1700)

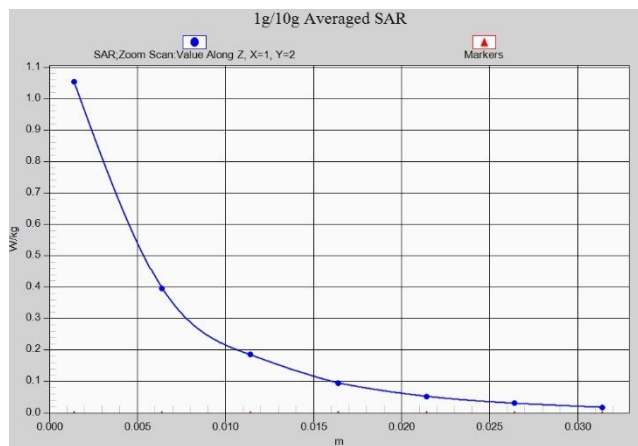

Fig. 1-9 Z-Scan at power reference point (WCDMA850)

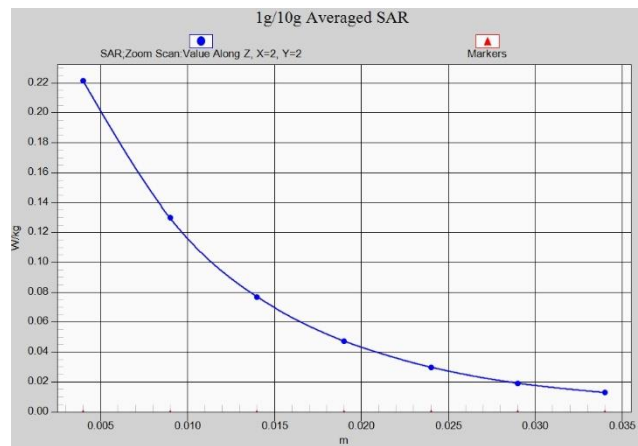

Fig. 1-10 Z-Scan at power reference point (WCDMA850)

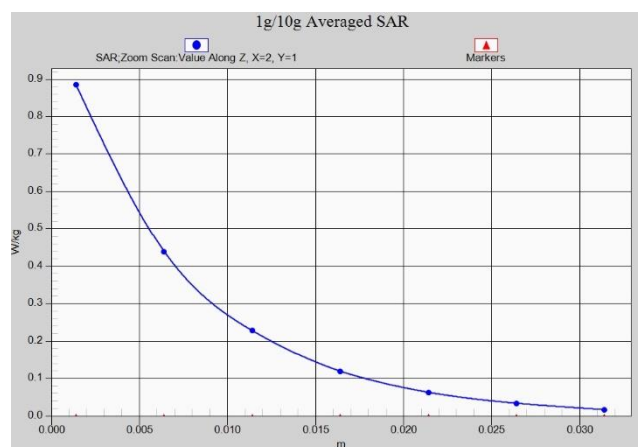

Fig. 1-11 Z-Scan at power reference point (LTE Band2)

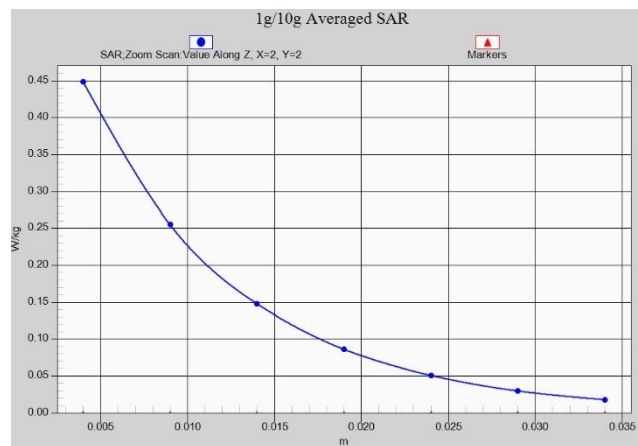

Fig. 1-12 Z-Scan at power reference point (LTE Band2)

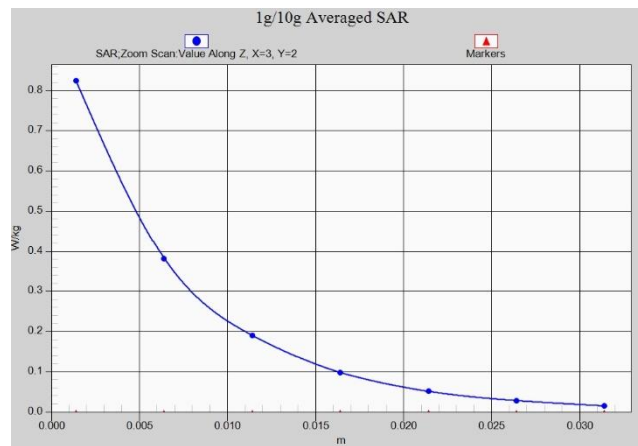

Fig. 1-13 Z-Scan at power reference point (LTE Band4)

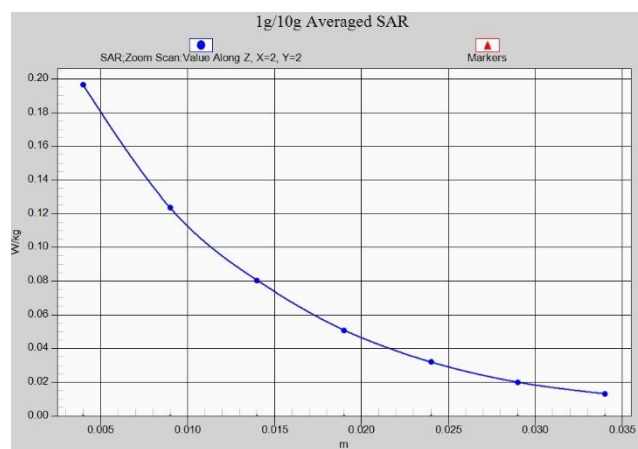

Fig. 1-14 Z-Scan at power reference point (LTE Band4)

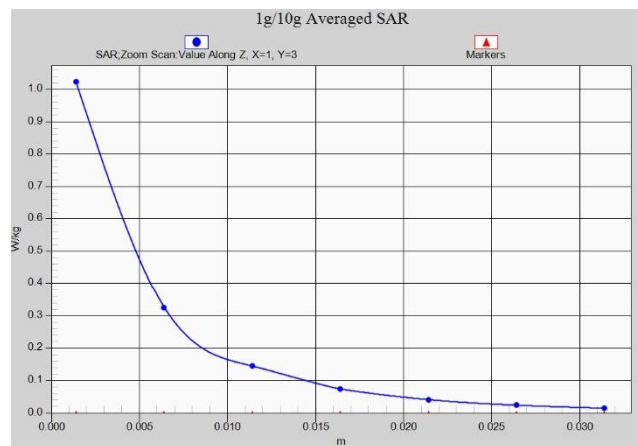

Fig. 1-15 Z-Scan at power reference point (LTE Band5)

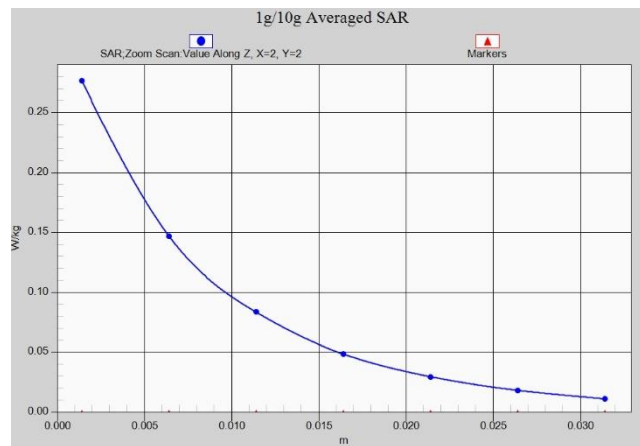

Fig. 1-16 Z-Scan at power reference point (LTE Band5)

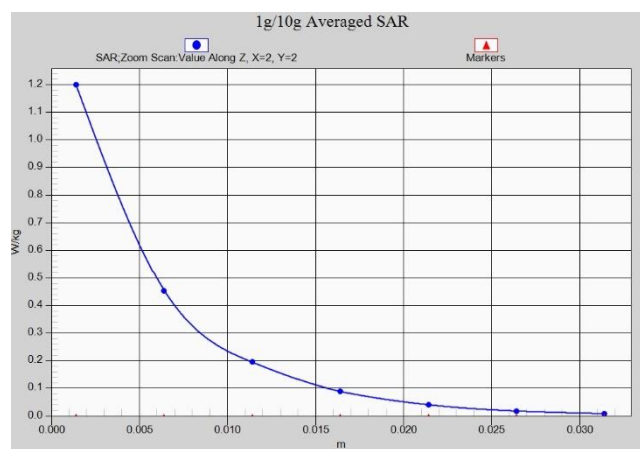

Fig. 1-17 Z-Scan at power reference point (LTE Band 7)

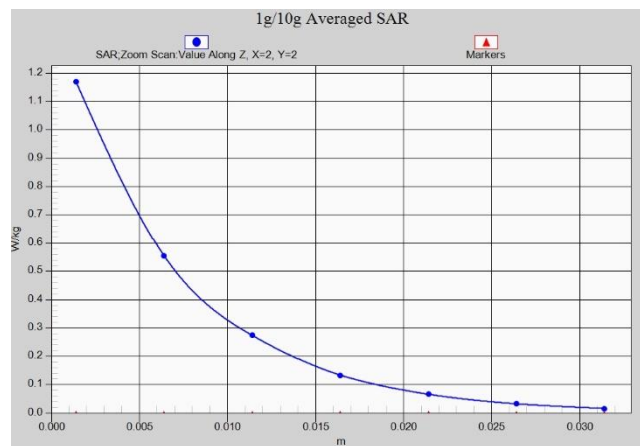

Fig. 1-18 Z-Scan at power reference point (LTE Band 7)