



BUREAU VERITAS

Test Report No.: RF200106W008-5



ACCREDITED

Certificate # 3939.01

FCC TEST REPORT (PART 24)

Applicant:	Xiaomi Communications Co., Ltd.
Address:	#019, 9th Floor, Building 6, 33 Xi'erqi Middle Road, Haidian District, Beijing, China,10085

Manufacturer or Supplier	Xiaomi Communications Co., Ltd.
Address	#019, 9th Floor, Building 6, 33 Xi'erqi Middle Road, Haidian District, Beijing, China,10085
Product	Mobile Phone
Brand Name	Redmi
Model Name	M2003J6A1G
FCC ID	2AFZZJ6A1G
Date of tests	Jan. 07, 2020 ~ Feb. 29, 2020

The tests have been carried out according to the requirements of the following standard:

- FCC PART 24, Subpart E FCC PART 2
 ANSI/TIA/EIA-603-D ANSI/TIA/EIA-603-E ANSI C63.26-2015

CONCLUSION: The submitted sample was found to COMPLY with the test requirement

Prepared by Alex Chen
Engineer / Mobile Department

Approved by Luke Lu
Manager / Mobile Department

Date: Feb. 29, 2020

Date: Feb. 29, 2020

This report is governed by, and incorporates by reference, CPS Conditions of Service as posted at the date of issuance of this report at <http://www.bureauveritas.com/home/about-us/our-business/cps/about-us/terms-conditions> and is intended for your exclusive use. Any copying or replication of this report to or for any other person or entity, or use of our name or trademark, is permitted only with our prior written permission. This report sets forth our findings solely with respect to the test samples identified herein. The results set forth in this report are not indicative or representative of the quality or characteristics of the lot from which a test sample was taken or any similar or identical product unless specifically and expressly noted. Our report includes all of the tests requested by you and the results thereof based upon the information that you provided to us. Measurement uncertainty is only provided upon request for accredited tests. You have 60 days from date of issuance of this report to notify us of any material error or omission caused by our negligence or if you require measurement uncertainty; provided, however, that such notice shall be in writing and shall specifically address the issue you wish to raise. A failure to raise such issue within the prescribed time shall constitute your unqualified acceptance of the completeness of this report, the tests conducted and the correctness of the report contents.



TABLE OF CONTENTS

RELEASE CONTROL RECORD 4

1 SUMMARY OF TEST RESULTS 5

1.1 MEASUREMENT UNCERTAINTY 5

1.2 TEST SITE AND INSTRUMENTS 6

2 GENERAL INFORMATION 7

2.1 GENERAL DESCRIPTION OF EUT 7

2.2 CONFIGURATION OF SYSTEM UNDER TEST 9

2.3 DESCRIPTION OF SUPPORT UNITS 11

2.4 TEST ITEM AND TEST CONFIGURATION 11

2.5 EUT OPERATING CONDITIONS 14

2.6 GENERAL DESCRIPTION OF APPLIED STANDARDS 14

3 TEST TYPES AND RESULTS 15

3.1 OUTPUT POWER MEASUREMENT 15

3.1.1 LIMITS OF OUTPUT POWER MEASUREMENT 15

3.1.2 TEST PROCEDURES 15

3.1.3 TEST SETUP 16

3.1.4 TEST RESULTS 18

3.2 FREQUENCY STABILITY MEASUREMENT 32

3.2.1 LIMITS OF FREQUENCY STABILITY MEASUREMENT 32

3.2.2 TEST PROCEDURE 32

3.2.3 TEST SETUP 32

3.2.4 TEST RESULTS 33

3.3 OCCUPIED BANDWIDTH MEASUREMENT 42

3.3.1 TEST PROCEDURES 42

3.3.2 TEST SETUP 42

3.3.3 TEST RESULTS 43

3.4 BAND EDGE MEASUREMENT 50

3.4.1 LIMITS OF BAND EDGE MEASUREMENT 50

3.4.2 TEST SETUP 50

3.4.3 TEST PROCEDURES 51

3.4.4 TEST RESULTS 52

3.5 CONDUCTED SPURIOUS EMISSIONS 71

3.5.1 LIMITS OF CONDUCTED SPURIOUS EMISSIONS MEASUREMENT 71

3.5.2 TEST PROCEDURE 71

3.5.3 TEST SETUP 71

3.5.4 TEST RESULTS 72

3.6 RADIATED EMISSION MEASUREMENT 81

3.6.1 LIMITS OF RADIATED EMISSION MEASUREMENT 81

3.6.2 TEST PROCEDURES 81

3.6.3 DEVIATION FROM TEST STANDARD 81

3.6.4 TEST SETUP 82

3.6.5 TEST RESULTS 83

3.7 PEAK TO AVERAGE RATIO 119

3.7.1 LIMITS OF PEAK TO AVERAGE RATIO MEASUREMENT 119

3.7.2 TEST SETUP 119

3.7.3 TEST PROCEDURES 119

3.7.4 TEST RESULTS 120



BUREAU VERITAS Test Report No.: RF200106W008-5

4	INFORMATION ON THE TESTING LABORATORIES.....	135
5	APPENDIX A – MODIFICATIONS RECORDERS FOR ENGINEERING CHANGES TO THE EUT BY THE LAB	136



BUREAU
VERITAS

Test Report No.: RF200106W008-5

RELEASE CONTROL RECORD

ISSUE NO.	REASON FOR CHANGE	DATE ISSUED
RF200106W008-5	Original release	Feb. 29, 2020



1 SUMMARY OF TEST RESULTS

The EUT has been tested according to the following specifications:

APPLIED STANDARD: FCC Part 24 & Part 2		
STANDARD SECTION	TEST TYPE	RESULT
2.1046 24.232	Equivalent Isotropic Radiated Power	Compliance
2.1055 24.235	Frequency Stability	Compliance
2.1049 24.238(b)	Occupied Bandwidth	Compliance
24.232(d)	Peak to average ratio	Compliance
24.238(b)	Band Edge Measurements	Compliance
2.1051 24.238	Conducted Spurious Emissions	Compliance
2.1053 24.238	Radiated Spurious Emissions	Compliance

1.1 MEASUREMENT UNCERTAINTY

Where relevant, the following measurement uncertainty levels have been estimated for tests performed on the EUT as specified in CISPR 16-4-2:

MEASUREMENT	UNCERTAINTY
Frequency Stability	± 76.97Hz
Radiated emissions & Radiated Power (30MHz~1GMHz)	±4.98dB
Radiated emissions & Radiated Power (1GMHz ~6GMHz)	±4.70dB
Radiated emissions (6GMHz ~18GMHz)	±4.60dB
Radiated emissions (18GMHz ~40GMHz)	±4.12dB
Conducted emissions	±4.01dB
Occupied Channel Bandwidth	±43.58KHz
Conducted Output power	±2.06dB
Band Edge Measurements	±4.70dB
Peak to average ratio	±0.76dB

This uncertainty represents an expanded uncertainty expressed at approximately the 95% confidence level using a coverage factor of k=2.



1.2 TEST SITE AND INSTRUMENTS

Equipment	Manufacturer	Model No.	Serial No.	Last Cal.	Next Cal.
MXE EMI Receiver	KEYSIGHT	N9038A-544	MY54450026	Feb. 26,20	Feb. 25,21
EXA Signal Analyzer	KEYSIGHT	N9010A-526	MY54510322	Feb. 26,20	Feb. 25,21
Bilog Antenna	ETS-LINDGREN	3143B	00161965	Feb. 26,20	Feb. 25,21
Horn Antenna (1GHz-18GHz)	ETS-LINDGREN	3117	00168692	Nov. 30, 19	Nov. 29, 20
Horn Antenna (18GHz-40GHz)	N/A	QWH-SL-18-40-K-SG/QMS-00361	15433	Nov. 21, 19	Nov. 20, 20
Radio Communication Analyzer	ANRITSU	MT8820C	6201465426	Feb. 26,20	Feb. 25,21
Signal Pre-Amplifier	EMSI	EMC 9135	980249	Jul. 08,19	Jul. 09,20
Signal Pre-Amplifier	EMSI	EMC 012645B	980257	Jul. 08,19	Jul. 09,20
Signal Pre-Amplifier	EMSI	EMC 184045B	980259	Jul. 08,19	Jul. 09,20
3m Semi-anechoic Chamber	ETS-LINDGREN	9m*6m*6m	Euroshieldpn-CT0001143-1216	Feb. 26,20	Feb. 25,21
Test Software	E3	V 9.160323	N/A	N/A	N/A
Test Software	ADT	ADT_Radiated_V7.6.15.9.2	N/A	N/A	N/A
10dB Attenuator	JFW/USA	50HF-010-SM A	1505	Jul. 08,19	Jul. 09,20
Power Meter	Anritsu	ML2495A	1506002	Feb. 26,20	Feb. 25,21
Power Sensor	Anritsu	MA2411B	1339352	Feb. 26,20	Feb. 25,21
Humid & Temp Programmable Tester	Juyi	ITH-120-45-CP-AR	IAA1504-001	Jul. 08,19	Jul. 09,20
MXG Analog Microwave Signal Generator	KEYSIGHT	N5183A	MY50143024	Feb. 26,20	Feb. 25,21
Power Divider	MCLI/USA	PS2-15	24880	Jul. 09,19	Jul. 08,20

- NOTE:**
1. The calibration interval of the above test instruments is 12 months or 24 months and the calibrations are traceable to CEPREI/CHINA, GRGT/CHINA and NIM/CHINA.
 2. The test was performed in 3m Semi-anechoic Chamber and RF Oven Room.
 3. The horn antenna is used only for the measurement of emission frequency above 1GHz if tested.
 4. The FCC Site Registration No. is 525120; The Designation No. is CN1171.



2 GENERAL INFORMATION

2.1 GENERAL DESCRIPTION OF EUT

PRODUCT	Mobile Phone	
BRAND NAME	Redmi	
MODEL NAME	M2003J6A1G	
POWER SUPPLY	5V/9V/10V/12Vdc (adapter or host equipment) 3.87Vdc (Li-ion, battery)	
MODULATION TYPE	GSM, GPRS: GMSK EDGE: 8PSK WCDMA : BPSK, QPSK LTE Band 2: QPSK, 16QAM, 64QAM	
FREQUENCY RANGE	GSM, GPRS, EDGE	1850.2MHz ~ 1909.8MHz
	WCDMA	1852.4MHz ~ 1907.6MHz
	LTE Band 2 Channel Bandwidth: 1.4MHz	1850.7MHz ~ 1909.3MHz
	LTE Band 2 Channel Bandwidth: 3MHz	1851.5MHz ~ 1908.5MHz
	LTE Band 2 Channel Bandwidth: 5MHz	1852.5MHz ~ 1907.5MHz
	LTE Band 2 Channel Bandwidth: 10MHz	1855.0MHz ~ 1905.0MHz
	LTE Band 2 Channel Bandwidth: 15MHz	1857.5MHz ~ 1902.5MHz
	LTE Band 2 Channel Bandwidth: 20MHz	1860.0MHz ~ 1900.0MHz
	MAX. EIRP POWER	GSM
EDGE		332mW
WCDMA		172mW
LTE Band 2 Channel Bandwidth: 1.4MHz		166mW
LTE Band 2 Channel Bandwidth: 3MHz		167mW
LTE Band 2 Channel Bandwidth: 5MHz		165mW
LTE Band 2 Channel Bandwidth: 10MHz		166mW
LTE Band 2 Channel Bandwidth: 15MHz		166mW
LTE Band 2 Channel Bandwidth: 20MHz		167mW



EMISSION DESIGNATOR	GSM	245KGXW
	EDGE	246KG7W
	WCDMA	4M16F9W
	LTE Band 2 Channel Bandwidth: 1.4MHz	QPSK: 1M09G7D
		16QAM: 1M09W7D
		64QAM: 1M09W7D
	LTE Band 2 Channel Bandwidth: 3MHz	QPSK: 2M69G7D
		16QAM: 2M68W7D
		64QAM: 2M68W7D
	LTE Band 2 Channel Bandwidth: 5MHz	QPSK: 4M49G7D
		16QAM: 4M49W7D
		64QAM: 4M47W7D
	LTE Band 2 Channel Bandwidth: 10MHz	QPSK: 8M96G7D
16QAM: 8M96W7D		
64QAM: 8M96W7D		
LTE Band 2 Channel Bandwidth: 15MHz	QPSK: 13M4G7D	
	16QAM: 13M4W7D	
	64QAM: 13M4W7D	
LTE Band 2 Channel Bandwidth: 20MHz	QPSK: 17M9G7D	
	16QAM: 18M0W7D	
	64QAM: 18M0W7D	
ANTENNA TYPE	Main Antenna(ANT 0): Fixed Internal Antenna with -0.5dBi gain for GSM 1900/WCDMA B2/LTE Band 2	
IMEI CODE	86590904	
HW VERSION	P1.1	
SW VERSION	MIUI 11	
I/O PORTS	Refer to user's manual	



NOTE:

1. For a more detailed features description, please refer to the manufacturer's specifications or the user's manual.
2. For the test results, the EUT had been tested with all conditions. But only the worst case was shown in test report.
3. The EUT incorporates a SISO function. Physically, the EUT provides one completed transmitter and one receiver.

MODULATION MODE	TX FUNCTION
GSM/GPRS/EDGE	1TX/1RX diversity
WCDMA	1TX/1RX diversity
LTE	1TX/1RX diversity

List of Accessory:

ACCESSORIES	BRAND	MODEL	MANUFACTURER	SPECIFICATION
AC Adapter 1	MI	MDY-11-EQ	HUIZHOU BYD ELECTRONIC CO., LTD.	I/P: 100 - 240Vac, 600mA, O/P: 5Vdc, 3000mA/9V,2230mA/12V,1670mA/10V, 2250mA
AC Adapter 2	MI	MDY-11-EQ	Jiangsu Chenyang Electron Co., Ltd.	I/P: 100 - 240Vac, 600mA, O/P: 5Vdc, 3000mA/9V,2230mA/12V,1670mA/10V, 2250mA
Battery	MI	BN55	SUNWODA	Rating :3.87Vdc, 4920mAh, Li-ion, Y
USB Cable 1	MI	H73312	Weihai HongLin Technology Group Co., Ltd.	1.0 meter, non-shielded cable, without ferrite core
USB Cable 2	MI	L73312	Luxshare Precision Industry Co., Ltd.	1.0 meter, non-shielded cable, without ferrite core



2.2 CONFIGURATION OF SYSTEM UNDER TEST

FOR RADIATION EMISSION TEST

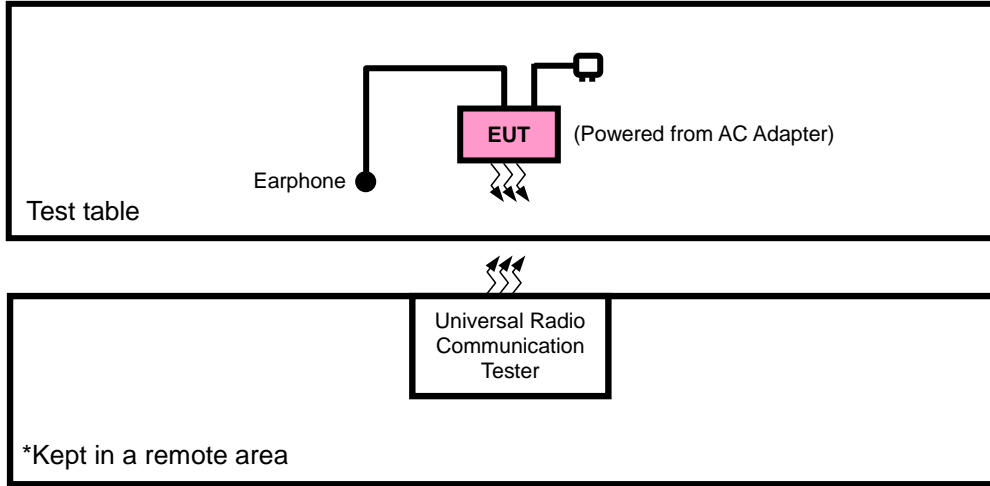



2.3 DESCRIPTION OF SUPPORT UNITS

The EUT has been tested as an independent unit together with other necessary accessories or support units. The following support units or accessories were used to form a representative test configuration during the tests.

NO.	PRODUCT	BRAND	MODEL NO.	SERIAL NO.	FCC ID
1	DC source	LONG WEI	PS-6403D	010934269	N/A

NO.	SIGNAL CABLE DESCRIPTION OF THE ABOVE SUPPORT UNITS
1	DC Line: Unshielded, Detachable 1.8m

2.4 TEST ITEM AND TEST CONFIGURATION

Pre-Scan has been conducted to determine the worst-case mode from all possible combinations between available modulations, data rates, XYZ axis and antenna ports

The worst case in EIRP and radiated emission was found when positioned on X-plane for GSM/EDGE/WCDMA/ LTE. Following channel(s) was (were) selected for the final test as listed below:

EUT CONFIGURE MODE	DESCRIPTION
A	EUT + Adapter + USB Cable with GSM ,WCDMA or LTE link
B	EUT + Battery with GSM ,WCDMA or LTE link

GSM MODE

EUT CONFIGURE MODE	TEST ITEM	AVAILABLE CHANNEL	TESTED CHANNEL	MODE
B	EIRP	512 to 810	512, 661, 810	GSM, EDGE
B	FREQUENCY STABILITY	512 to 810	512, 810	GSM, EDGE
B	OCCUPIED BANDWIDTH	512 to 810	512, 661, 810	GSM, EDGE
B	PEAK TO AVERAGE RATIO	512 to 810	512, 661, 810	GSM, EDGE
B	BAND EDGE	512 to 810	512, 810	GSM, EDGE
B	CONDCUDED EMISSION	512 to 810	512, 661, 810	GSM, EDGE
A	RADIATED EMISSION	512 to 810	512, 661, 810	GSM, EDGE



WCDMA MODE

EUT CONFIGURE MODE	TEST ITEM	AVAILABLE CHANNEL	TESTED CHANNEL	MODE
B	EIRP	9262 to 9538	9262, 9400, 9538	WCDMA
B	FREQUENCY STABILITY	9262 to 9538	9262, 9538	WCDMA
B	OCCUPIED BANDWIDTH	9262 to 9538	9262, 9400, 9538	WCDMA
B	PEAK TO AVERAGE RATIO	9262 to 9538	9262, 9400, 9538	WCDMA
B	BAND EDGE	9262 to 9538	9262, 9538	WCDMA
B	CONDCUDED EMISSION	9262 to 9538	9262, 9400, 9538	WCDMA
A	RADIATED EMISSION	9262 to 9538	9262, 9400, 9538	WCDMA

LTE BAND 2

EUT CONFIGURE MODE	TEST ITEM	AVAILABLE CHANNEL	TESTED CHANNEL	CHANNEL BANDWIDTH	MODULATION	MODE
B	EIRP	18607 to 19193	18607, 18900, 19193	1.4MHz	QPSK,16QAM, 64QAM	1 RB / 0 RB Offset
		18615 to 19185	18615, 18900, 19185	3MHz	QPSK,16QAM, 64QAM	1 RB / 0 RB Offset
		18625 to 19175	18625, 18900, 19175	5MHz	QPSK,16QAM, 64QAM	1 RB / 0 RB Offset
		18650 to 19150	18650, 18900, 19150	10MHz	QPSK,16QAM, 64QAM	1 RB / 0 RB Offset
		18675 to 19125	18675, 18900, 19125	15MHz	QPSK,16QAM, 64QAM	1 RB / 0 RB Offset
		18700 to 19100	18700, 18900, 19100	20MHz	QPSK,16QAM, 64QAM	1 RB / 0 RB Offset
B	FREQUENCY STABILITY	18607 to 19193	18607, 19193	1.4MHz	QPSK	1 RB / 0 RB Offset
		18615 to 19185	18615, 19185	3MHz	QPSK	1 RB / 0 RB Offset
		18625 to 19175	18625, 19175	5MHz	QPSK	1 RB / 0 RB Offset
		18650 to 19150	18650, 19150	10MHz	QPSK	1 RB / 0 RB Offset
		18675 to 19125	18675, 19125	15MHz	QPSK	1 RB / 0 RB Offset
		18700 to 19100	18700, 19100	20MHz	QPSK	1 RB / 0 RB Offset
B	OCCUPIED BANDWIDTH	18607 to 19193	18607, 18900, 19193	1.4MHz	QPSK,16QAM, 64QAM	6 RB / 0 RB Offset
		18615 to 19185	18615, 18900, 19185	3MHz	QPSK,16QAM, 64QAM	15 RB / 0 RB Offset
		18625 to 19175	18625, 18900, 19175	5MHz	QPSK,16QAM, 64QAM	25 RB / 0 RB Offset
		18650 to 19150	18650, 18900, 19150	10MHz	QPSK,16QAM, 64QAM	50 RB / 0 RB Offset
		18675 to 19125	18675, 18900, 19125	15MHz	QPSK,16QAM, 64QAM	75 RB / 0 RB Offset
		18700 to 19100	18700, 18900, 19100	20MHz	QPSK,16QAM, 64QAM	100 RB / 0 RB Offset
B	PEAK TO AVERAGE RATIO	18607 to 19193	18607, 18900, 19193	1.4MHz	QPSK,16QAM, 64QAM	1 RB / 0 RB Offset
		18615 to 19185	18615, 18900, 19185	3MHz	QPSK,16QAM, 64QAM	1 RB / 0 RB Offset
		18625 to 19175	18625, 18900, 19175	5MHz	QPSK,16QAM, 64QAM	1 RB / 0 RB Offset
		18650 to 19150	18650, 18900, 19150	10MHz	QPSK,16QAM, 64QAM	1 RB / 0 RB Offset
		18675 to 19125	18675, 18900, 19125	15MHz	QPSK,16QAM, 64QAM	1 RB / 0 RB Offset
		18700 to 19100	18700, 18900, 19100	20MHz	QPSK,16QAM, 64QAM	1 RB / 0 RB Offset



B	BAND EDGE	18607 to 19193	18607	1.4MHz	QPSK,16QAM, 64QAM	1 RB / 0 RB Offset		
			19193	1.4MHz	QPSK,16QAM, 64QAM	6 RB / 0 RB Offset		
		18615 to 19185	18615	3MHz	QPSK,16QAM, 64QAM	1 RB / 5 RB Offset		
			19185	3MHz	QPSK,16QAM, 64QAM	6 RB / 0 RB Offset		
		18625 to 19175	18625	5MHz	QPSK,16QAM, 64QAM	1 RB / 0 RB Offset		
			19175	5MHz	QPSK,16QAM, 64QAM	15 RB / 0 RB Offset		
		18650 to 19150	18650	10MHz	QPSK,16QAM, 64QAM	1 RB / 14 RB Offset		
			19150	10MHz	QPSK,16QAM, 64QAM	15 RB / 0 RB Offset		
		18675 to 19125	18675	15MHz	QPSK,16QAM, 64QAM	1 RB / 0 RB Offset		
			19125	15MHz	QPSK,16QAM, 64QAM	25 RB / 0 RB Offset		
		18700 to 19100	18700	20MHz	QPSK,16QAM, 64QAM	1 RB / 24 RB Offset		
			19100	20MHz	QPSK,16QAM, 64QAM	25 RB / 0 RB Offset		
		B	CONDCUETED EMISSION	18607 to 19193	18607, 18900, 19193	1.4MHz	QPSK	1 RB / 0 RB Offset
				18615 to 19185	18615, 18900, 19185	3MHz	QPSK	50 RB / 0 RB Offset
				18625 to 19175	18625, 18900, 19175	5MHz	QPSK	1 RB / 49 RB Offset
				18650 to 19150	18650, 18900, 19150	10MHz	QPSK	50 RB / 0 RB Offset
18675 to 19125	18675, 18900, 19125			15MHz	QPSK	1 RB / 0 RB Offset		
18700 to 19100	18700, 18900, 19100			20MHz	QPSK	75 RB / 0 RB Offset		
A	RADIATED EMISSION	18607 to 19193	18900	1.4MHz	QPSK	1 RB / 0 RB Offset		
		18615 to 19185	18900	3MHz	QPSK	1 RB / 0 RB Offset		
		18625 to 19175	18900	5MHz	QPSK	1 RB / 0 RB Offset		
		18650 to 19150	18650, 18900, 19150	10MHz	QPSK	1 RB / 0 RB Offset		
		18675 to 19125	18900	15MHz	QPSK	1 RB / 0 RB Offset		
		18700 to 19100	18900	20MHz	QPSK	1 RB / 0 RB Offset		

TEST CONDITION:

TEST ITEM	ENVIRONMENTAL CONDITIONS	INPUT POWER	TESTED BY
EIRP	25deg. C, 57%RH	DC 3.87V By Battery	Jacky Liu
FREQUENCY STABILITY	23deg. C, 61%RH	DC 3.6V/3.87V/4.45V	Harris Wang
OCCUPIED BANDWIDTH	23deg. C, 61%RH	DC 3.87V By Battery	Harris Wang
PEAK TO AVERAGE RATIO	23deg. C, 61%RH	DC 3.87V By Battery	Harris Wang
BAND EDGE	23deg. C, 61%RH	DC 3.87V By Battery	Harris Wang
CONDCUETED EMISSION	23deg. C, 61%RH	DC 3.87V By Battery	Harris Wang
RADIATED EMISSION	23deg. C, 70%RH	DC 5/9/10/12V By Adapter	Jacky Liu



2.5 EUT OPERATING CONDITIONS

The EUT makes a call to the communication simulator. The communication simulator station system controlled a EUT to export maximum output power under transmission mode and specific channel frequency

2.6 GENERAL DESCRIPTION OF APPLIED STANDARDS

The EUT is a RF product. According to the specifications of the manufacturer, it must comply with the requirements of the following standards:

FCC 47 CFR Part 2

FCC 47 CFR Part 24

KDB 971168 D01 Power Meas License Digital Systems v03r01

ANSI/TIA/EIA-603-D

ANSI/TIA/EIA-603-E

ANSI C63.26-2015

NOTE: All test items have been performed and recorded as per the above standards.



3 TEST TYPES AND RESULTS

3.1 OUTPUT POWER MEASUREMENT

3.1.1 LIMITS OF OUTPUT POWER MEASUREMENT

Mobile and portable stations are limited to 2 watts EIRP.

3.1.2 TEST PROCEDURES

EIRP MEASUREMENT:

- a. All measurements were done at low, middle and high operational frequency range. RBW and VBW is 1MHz for GSM & GPRS, 5MHz for WCDMA mode and 10MHz for LTE mode.
- b. Substitution method is used for E.I.R.P measurement. In the semi-anechoic chamber, EUT placed on the 0.8m height of Turn Table, rotated the table around 360 degrees to search the maximum radiation power and receiver antenna shall be rotated vertical and horizontal polarization and moved height from 1m to 4m to find the maximum polar radiated power. The “Read Value” is the spectrum reading the maximum power value.
- c. The substitution horn antenna is substituted for EUT at the same position and signals generator export the CW signal to the substitution antenna via a tx cable. Rotated the Turn Table and moved receiving antenna to find the maximum radiation power. Adjust output power level of S.G to get a Value of spectrum reading equal to “Read Value“ of step b. Record the power level of S.G
- d. $EIRP = \text{Output power level of S.G} - \text{TX cable loss} + \text{Antenna gain of substitution horn.}$

CONDUCTED POWER MEASUREMENT:

The EUT was set up for the maximum power with WCDMA link data modulation and link up with simulator. Set the EUT to transmit under low, middle and high channel and record the power level shown on simulator.



3.1.3 TEST SETUP

EIRP / ERP Measurement:

<Radiated Emission below or equal 1 GHz>

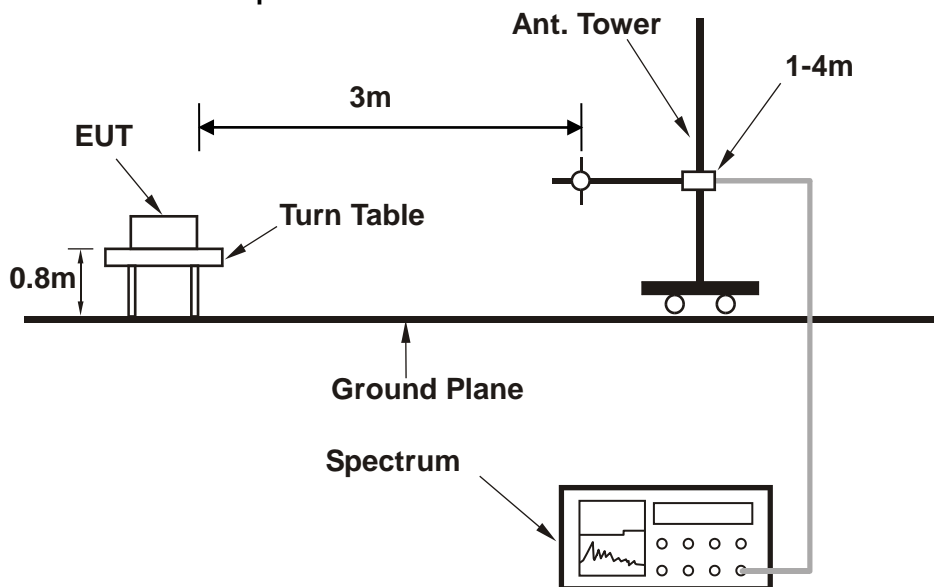

<Frequency Range above 1GHz>

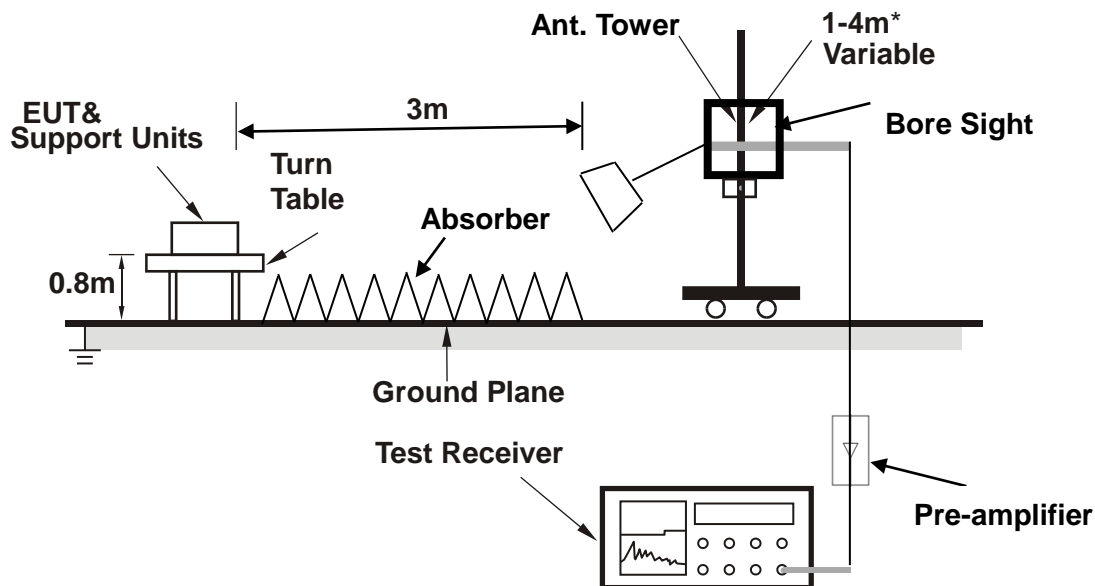

Note: Above 1G is a directional antenna

Depends on the EUT height and the antenna 3dB beamwidth both, refer to section 7.3 of CISPR 16-2-3.

For the actual test configuration, please refer to the attached file (Test Setup Photo).



CONDUCTED POWER MEASUREMENT:





3.1.4 TEST RESULTS

CONDUCTED OUTPUT POWER (dBm)

Band	GSM1900			Max. Tune-up Power
Channel	512	661	810	
Frequency	1850.2	1880	1909.8	
GSM	29.80	29.85	29.73	30.50
GPRS 1Tx Slot	29.79	29.84	29.72	30.50
GPRS 2Tx Slot	26.11	26.16	26.04	28.00
GPRS 3Tx Slot	24.65	24.70	24.58	26.00
GPRS 4Tx Slot	23.19	23.24	23.12	25.00
EDGE 1Tx Slot (MCS9)	25.66	25.71	25.59	27.50
EDGE 2Tx Slot (MCS9)	22.53	22.58	22.46	24.00
EDGE 3Tx Slot (MCS9)	20.71	20.76	20.64	22.50
EDGE 4Tx Slot (MCS9)	19.63	19.68	19.56	21.50

Band	WCDMA II			Max. Tune-up Power
TX Channel	9262	9400	9538	
Rx Channel	9662	9800	9938	
Frequency	1852.4	1880	1907.6	
RMC 12.2K	22.88	22.77	22.86	24.00
HSDPA Subtest-1	21.92	21.83	21.89	22.50
HSDPA Subtest-2	21.89	21.80	21.86	22.50
HSDPA Subtest-3	21.38	21.29	21.35	22.50
HSDPA Subtest-4	21.33	21.24	21.30	22.50
DC-HSDPA Subtest-1	21.89	21.80	21.85	22.50
DC-HSDPA Subtest-2	21.88	21.77	21.83	22.50
DC-HSDPA Subtest-3	21.36	21.30	21.33	22.50
DC-HSDPA Subtest-4	21.34	21.28	21.31	22.50
HSUPA Subtest-1	21.87	21.78	21.84	22.50
HSUPA Subtest-2	19.86	19.77	19.83	21.50
HSUPA Subtest-3	20.91	20.82	20.88	22.00
HSUPA Subtest-4	19.82	19.73	19.79	21.50
HSUPA Subtest-5	21.80	21.71	21.77	22.50
HSPA+ Subtest-1	19.41	19.38	19.42	21.00



LTE Band 2								
BW	MCS Index	RB Size	RB Offset	Low	Mid	High	3GPP MPR (dB)	Max. Tune-up (dBm)
		Channel		Low CH 18700	Mid CH 18900	High CH 19100		
		Frequency (MHz)		Frequency 1860 MHz	Frequency 1880 MHz	Frequency 1900 MHz		
20M	QPSK	1	0	22.65	22.74	22.63	0	24
		1	50	22.59	22.68	22.57	0	24
		1	99	22.43	22.52	22.41	0	24
		50	0	21.60	21.69	21.58	1	23
		50	25	21.56	21.65	21.54	1	23
		50	50	21.52	21.61	21.50	1	23
		100	0	21.57	21.66	21.55	1	23
	16QAM	1	0	21.97	22.06	21.95	1	23
		1	50	21.85	21.94	21.83	1	23
		1	99	21.68	21.77	21.66	1	23
		50	0	20.73	20.82	20.71	2	22
		50	25	20.71	20.80	20.69	2	22
		50	50	20.62	20.71	20.60	2	22
		100	0	20.64	20.73	20.62	2	22
	64QAM	1	0	20.83	20.92	20.81	2	22
		1	50	20.75	20.84	20.73	2	22
		1	99	20.60	20.69	20.58	2	22
		50	0	19.66	19.75	19.64	3	21
		50	25	19.69	19.78	19.67	3	21
		50	50	19.59	19.68	19.57	3	21
		100	0	19.64	19.73	19.62	3	21



BW	MCS Index	Channel		Low CH 18675	Mid CH 18900	High CH 19125	3GPP MPR	Max. Tune-up
		Frequency (MHz)		Frequency 1857.5 MHz	Frequency 1880 MHz	Frequency 1902.5 MHz		
15M	QPSK	1	0	22.64	22.70	22.55	0	24
		1	37	22.55	22.65	22.51	0	24
		1	74	22.41	22.51	22.37	0	24
		36	0	21.54	21.64	21.57	1	23
		36	19	21.55	21.63	21.49	1	23
		36	39	21.44	21.54	21.48	1	23
		75	0	21.56	21.62	21.52	1	23
	16QAM	1	0	21.94	22.05	21.89	1	23
		1	37	21.81	21.89	21.81	1	23
		1	74	21.62	21.75	21.63	1	23
		36	0	20.71	20.74	20.70	2	22
		36	19	20.63	20.76	20.64	2	22
		36	39	20.59	20.65	20.58	2	22
		75	0	20.63	20.68	20.54	2	22
	64QAM	1	0	20.77	20.89	20.77	2	22
		1	37	20.73	20.77	20.68	2	22
		1	74	20.54	20.61	20.56	2	22
		36	0	19.65	19.73	19.56	3	21
		36	19	19.62	19.70	19.61	3	21
		36	39	19.57	19.67	19.53	3	21
		75	0	19.62	19.65	19.61	3	21



BW	MCS Index	Channel		Low CH 18650	Mid CH 18900	High CH 19150	3GPP MPR	Max. Tune-up
		Frequency (MHz)		Frequency 1855 MHz	Frequency 1880 MHz	Frequency 1905 MHz		
10M	QPSK	1	0	22.57	22.70	22.58	0	24
		1	24	22.57	22.60	22.56	0	24
		1	49	22.35	22.48	22.36	0	24
		25	0	21.57	21.63	21.56	1	23
		25	12	21.54	21.58	21.49	1	23
		25	25	21.46	21.53	21.48	1	23
		50	0	21.56	21.64	21.47	1	23
	16QAM	1	0	21.90	21.98	21.89	1	23
		1	24	21.82	21.88	21.81	1	23
		1	49	21.66	21.70	21.61	1	23
		25	0	20.67	20.74	20.69	2	22
		25	12	20.69	20.72	20.68	2	22
		25	25	20.54	20.67	20.55	2	22
		50	0	20.62	20.65	20.61	2	22
	64QAM	1	0	20.75	20.88	20.76	2	22
		1	24	20.72	20.78	20.71	2	22
		1	49	20.58	20.62	20.53	2	22
		25	0	19.60	19.67	19.62	3	21
		25	12	19.68	19.76	19.59	3	21
		25	25	19.54	19.60	19.51	3	21
		50	0	19.63	19.67	19.60	3	21



BW	MCS Index	Channel		Low CH 18625	Mid CH 18900	High CH 19175	3GPP MPR	Max. Tune-up
		Frequency (MHz)		Frequency 1852.5 MHz	Frequency 1880 MHz	Frequency 1907.5 MHz		
5M	QPSK	1	0	22.60	22.67	22.58	0	24
		1	12	22.57	22.60	22.55	0	24
		1	24	22.38	22.44	22.40	0	24
		12	0	21.56	21.64	21.53	1	23
		12	6	21.48	21.64	21.49	1	23
		12	13	21.48	21.56	21.49	1	23
		25	0	21.51	21.64	21.50	1	23
	16QAM	1	0	21.90	22.01	21.93	1	23
		1	12	21.77	21.92	21.78	1	23
		1	24	21.66	21.69	21.64	1	23
		12	0	20.65	20.76	20.63	2	22
		12	6	20.65	20.78	20.63	2	22
		12	13	20.55	20.66	20.58	2	22
		25	0	20.58	20.66	20.57	2	22
	64QAM	1	0	20.76	20.87	20.79	2	22
		1	12	20.67	20.82	20.67	2	22
		1	24	20.52	20.68	20.56	2	22
		12	0	19.62	19.70	19.56	3	21
		12	6	19.61	19.77	19.65	3	21
		12	13	19.55	19.63	19.49	3	21
		25	0	19.58	19.71	19.59	3	21



BW	MCS Index	Channel		Low CH 18615	Mid CH 18900	High CH 19185	3GPP MPR	Max. Tune-up
		Frequency (MHz)		Frequency 1851.5 MHz	Frequency 1880 MHz	Frequency 1908.5 MHz		
3M	QPSK	1	0	22.59	22.72	22.57	0	24
		1	12	22.52	22.63	22.55	0	24
		1	24	22.37	22.45	22.36	0	24
		12	0	21.53	21.64	21.56	1	23
		12	6	21.48	21.63	21.48	1	23
		12	13	21.44	21.60	21.48	1	23
		25	0	21.53	21.61	21.47	1	23
	16QAM	1	0	21.89	22.05	21.93	1	23
		1	12	21.80	21.89	21.79	1	23
		1	24	21.66	21.69	21.65	1	23
		12	0	20.65	20.78	20.66	2	22
		12	6	20.68	20.74	20.67	2	22
		12	13	20.60	20.64	20.55	2	22
		25	0	20.58	20.65	20.60	2	22
	64QAM	1	0	20.82	20.90	20.73	2	22
		1	12	20.70	20.76	20.67	2	22
		1	24	20.59	20.63	20.56	2	22
		12	0	19.61	19.73	19.57	3	21
		12	6	19.67	19.70	19.66	3	21
		12	13	19.51	19.64	19.52	3	21
		25	0	19.62	19.65	19.61	3	21



BW	MCS Index	Channel		Low CH 18700	Mid CH 18900	High CH 19100	3GPP MPR	Max. Tune-up
		Frequency (MHz)		Frequency 1860 MHz	Frequency 1880 MHz	Frequency 1900 MHz		
1.4M	QPSK	1	0	22.57	22.70	22.58	0	24
		1	12	22.56	22.62	22.55	0	24
		1	24	22.41	22.45	22.36	0	24
		12	0	22.54	22.61	22.56	1	23
		12	6	22.55	22.63	22.46	1	23
		12	13	22.47	22.53	22.44	1	23
		25	0	21.56	21.60	21.53	1	23
	16QAM	1	0	21.92	21.99	21.90	1	23
		1	12	21.83	21.86	21.81	1	23
		1	24	21.63	21.69	21.65	1	23
		12	0	21.69	21.77	21.66	2	22
		12	6	21.63	21.79	21.64	2	22
		12	13	21.58	21.66	21.59	2	22
		25	0	20.58	20.71	20.57	2	22
	64QAM	1	0	20.76	20.87	20.79	2	22
		1	12	20.67	20.82	20.68	2	22
		1	24	20.58	20.61	20.56	2	22
		12	0	20.58	20.69	20.56	3	21
		12	6	20.63	20.76	20.61	3	21
		12	13	20.54	20.60	20.56	3	21
		25	0	19.60	19.68	19.57	3	21



EIRP POWER (dBm)

GSM

Channel	Frequency (MHz)	Conducted Power (dBm)	G _T -L _c (dB)	EIRP (dBm)	EIRP (mW)	Limit (W)
512	1850.2	29.80	-0.50	29.30	851.14	2
661	1880.0	29.85	-0.50	29.35	860.99	2
810	1909.8	29.73	-0.50	29.23	837.53	2

REMARKS: 1. EIRP Output Power (dBm) = SPA LVL (dBm) + Correction Factor (dB).
 2. Correction factor (dB) = Free Space Loss + Antenna Factor + Cable Loss

EDGE

Channel	Frequency (MHz)	Conducted Power (dBm)	G _T -L _c (dB)	EIRP (dBm)	EIRP (mW)	Limit (W)
512	1850.2	25.66	-0.50	25.16	328.10	2
661	1880.0	25.71	-0.50	25.21	331.89	2
810	1909.8	25.59	-0.50	25.09	322.85	2

REMARKS: 1. EIRP Output Power (dBm) = SPA LVL (dBm) + Correction Factor (dB).
 2. Correction factor (dB) = Free Space Loss + Antenna Factor + Cable Loss

WCDMA

Channel	Frequency (MHz)	Conducted Power (dBm)	G _T -L _c (dB)	EIRP (dBm)	EIRP (mW)	Limit (W)
9262	1852.4	22.80	-0.50	22.30	169.82	2
9400	1880.0	22.77	-0.50	22.27	168.66	2
9538	1907.6	22.86	-0.50	22.36	172.19	2

REMARKS: 1. EIRP Output Power (dBm) = SPA LVL (dBm) + Correction Factor (dB).
 2. Correction factor (dB) = Free Space Loss + Antenna Factor + Cable Loss



LTE BAND 2

CHANNEL BANDWIDTH: 1.4MHz QPSK

Channel	Frequency (MHz)	Conducted Power (dBm)	G _T -L _c (dB)	EIRP (dBm)	EIRP (mW)	Limit (W)
18607	1850.7	22.57	-0.50	22.07	161.06	2
18900	1880.0	22.70	-0.50	22.20	165.96	2
19193	1908.3	22.58	-0.50	22.08	161.44	2

CHANNEL BANDWIDTH: 1.4MHz 16QAM

Channel	Frequency (MHz)	Conducted Power (dBm)	G _T -L _c (dB)	EIRP (dBm)	EIRP (mW)	Limit (W)
18607	1850.7	21.92	-0.50	21.42	138.68	2
18900	1880.0	21.99	-0.50	21.49	140.93	2
19193	1908.3	21.90	-0.50	21.40	138.04	2

CHANNEL BANDWIDTH: 1.4MHz 64QAM

Channel	Frequency (MHz)	Conducted Power (dBm)	G _T -L _c (dB)	EIRP (dBm)	EIRP (mW)	Limit (W)
18607	1850.7	20.76	-0.50	20.26	106.17	2
18900	1880.0	20.87	-0.50	20.37	108.89	2
19193	1908.3	20.79	-0.50	20.29	106.91	2



CHANNEL BANDWIDTH: 3MHz QPSK

Channel	Frequency (MHz)	Conducted Power (dBm)	G _T -L _c (dB)	EIRP (dBm)	EIRP (mW)	Limit (W)
18615	1851.5	22.59	-0.50	22.09	161.81	2
18900	1880.0	22.72	-0.50	22.22	166.72	2
19185	1908.5	22.57	-0.50	22.07	161.06	2

CHANNEL BANDWIDTH: 3MHz 16QAM

Channel	Frequency (MHz)	Conducted Power (dBm)	G _T -L _c (dB)	EIRP (dBm)	EIRP (mW)	Limit (W)
18615	1851.5	21.89	-0.50	21.39	137.72	2
18900	1880.0	22.05	-0.50	21.55	142.89	2
19185	1908.5	21.93	-0.50	21.43	139.00	2

CHANNEL BANDWIDTH: 3MHz 64QAM

Channel	Frequency (MHz)	Conducted Power (dBm)	G _T -L _c (dB)	EIRP (dBm)	EIRP (mW)	Limit (W)
18615	1851.5	20.82	-0.50	20.32	107.65	2
18900	1880.0	20.90	-0.50	20.40	109.65	2
19185	1908.5	20.73	-0.50	20.23	105.44	2



CHANNEL BANDWIDTH: 5MHz QPSK

Channel	Frequency (MHz)	Conducted Power (dBm)	G _T -L _c (dB)	EIRP (dBm)	EIRP (mW)	Limit (W)
18625	1852.5	22.60	-0.50	22.10	162.18	2
18900	1880.0	22.67	-0.50	22.17	164.82	2
19175	1907.5	22.58	-0.50	22.08	161.44	2

CHANNEL BANDWIDTH: 5MHz 16QAM

Channel	Frequency (MHz)	Conducted Power (dBm)	G _T -L _c (dB)	EIRP (dBm)	EIRP (mW)	Limit (W)
18625	1852.5	21.90	-0.50	21.40	138.04	2
18900	1880.0	22.01	-0.50	21.51	141.58	2
19175	1907.5	21.93	-0.50	21.43	139.00	2

CHANNEL BANDWIDTH: 5MHz 64QAM

Channel	Frequency (MHz)	Conducted Power (dBm)	G _T -L _c (dB)	EIRP (dBm)	EIRP (mW)	Limit (W)
18625	1852.5	20.76	-0.50	20.26	106.17	2
18900	1880.0	20.87	-0.50	20.37	108.89	2
19175	1907.5	20.79	-0.50	20.29	106.91	2



CHANNEL BANDWIDTH: 10MHz QPSK

Channel	Frequency (MHz)	Conducted Power (dBm)	G _T -L _C (dB)	EIRP (dBm)	EIRP (mW)	Limit (W)
18650	1855.0	22.57	-0.50	22.07	161.06	2
18900	1880.0	22.70	-0.50	22.20	165.96	2
19150	1905.0	22.58	-0.50	22.08	161.44	2

CHANNEL BANDWIDTH: 10MHz 16QAM

Channel	Frequency (MHz)	Conducted Power (dBm)	G _T -L _C (dB)	EIRP (dBm)	EIRP (mW)	Limit (W)
18650	1855.0	21.90	-0.50	21.40	138.04	2
18900	1880.0	21.98	-0.50	21.48	140.60	2
19150	1905.0	21.89	-0.50	21.39	137.72	2

CHANNEL BANDWIDTH: 10MHz 64QAM

Channel	Frequency (MHz)	Conducted Power (dBm)	G _T -L _C (dB)	EIRP (dBm)	EIRP (mW)	Limit (W)
18650	1855.0	20.75	-0.50	20.25	105.93	2
18900	1880.0	20.88	-0.50	20.38	109.14	2
19150	1905.0	20.76	-0.50	20.26	106.17	2



CHANNEL BANDWIDTH: 15MHz QPSK

Channel	Frequency (MHz)	Conducted Power (dBm)	G _T -L _c (dB)	EIRP (dBm)	EIRP (mW)	Limit (W)
18675	1857.5	22.64	-0.50	22.14	163.68	2
18900	1880.0	22.70	-0.50	22.20	165.96	2
19125	1902.5	22.55	-0.50	22.05	160.32	2

CHANNEL BANDWIDTH: 15MHz 16QAM

Channel	Frequency (MHz)	Conducted Power (dBm)	G _T -L _c (dB)	EIRP (dBm)	EIRP (mW)	Limit (W)
18675	1857.5	21.94	-0.50	21.44	139.32	2
18900	1880.0	22.02	-0.50	21.52	141.91	2
19125	1902.5	21.89	-0.50	21.39	137.72	2

CHANNEL BANDWIDTH: 15MHz 64QAM

Channel	Frequency (MHz)	Conducted Power (dBm)	G _T -L _c (dB)	EIRP (dBm)	EIRP (mW)	Limit (W)
18675	1857.5	20.77	-0.50	20.27	106.41	2
18900	1880.0	20.89	-0.50	20.39	109.4	2
19125	1902.5	20.77	-0.50	20.27	106.41	2



CHANNEL BANDWIDTH: 20MHz QPSK

Channel	Frequency (MHz)	Conducted Power (dBm)	G _T -L _c (dB)	EIRP (dBm)	EIRP (mW)	Limit (W)
18675	1857.5	22.65	-0.50	22.15	164.06	2
18900	1880.0	22.74	-0.50	22.24	167.49	2
19125	1902.5	22.63	-0.50	22.13	163.31	2

CHANNEL BANDWIDTH: 20MHz 16QAM

Channel	Frequency (MHz)	Conducted Power (dBm)	G _T -L _c (dB)	EIRP (dBm)	EIRP (mW)	Limit (W)
18675	1857.5	21.97	-0.50	21.47	140.28	2
18900	1880.0	22.06	-0.50	21.56	143.22	2
19125	1902.5	21.95	-0.50	21.45	139.64	2

CHANNEL BANDWIDTH: 20MHz 64QAM

Channel	Frequency (MHz)	Conducted Power (dBm)	G _T -L _c (dB)	EIRP (dBm)	EIRP (mW)	Limit (W)
18675	1857.5	20.83	-0.50	20.33	107.89	2
18900	1880.0	20.92	-0.50	20.42	110.15	2
19125	1902.5	20.81	-0.50	20.31	107.4	2

- REMARKS:** 1. EIRP Output Power (dBm) = SPA LVL (dBm) + Correction Factor (dB).
 2. Correction factor (dB) = Free Space Loss + Antenna Factor + Cable Loss



3.2 FREQUENCY STABILITY MEASUREMENT

3.2.1 LIMITS OF FREQUENCY STABILITY MEASUREMENT

The frequency stability shall be sufficient to ensure that the fundamental emission stays within the authorized frequency block.

3.2.2 TEST PROCEDURE

- a. Device is placed at the oven room. The oven room could control the temperatures and humidity. Power warm up is at least 15 min and power applied should perform before recording frequency error.
- b. EUT is connected the external power supply to control the DC input power. The test voltage range is from minimum to maximum working voltage. Each step shall be record the frequency error rate.
- c. The temperature range step is 10 degrees in this test items. All temperature levels shall be hold the $\pm 0.5^{\circ}\text{C}$ during the measurement testing. The each temperature step shall be at least 0.5 hours, consider the EUT could be test under the stability condition.

NOTE: The frequency error was recorded frequency error from the communication simulator.

3.2.3 TEST SETUP

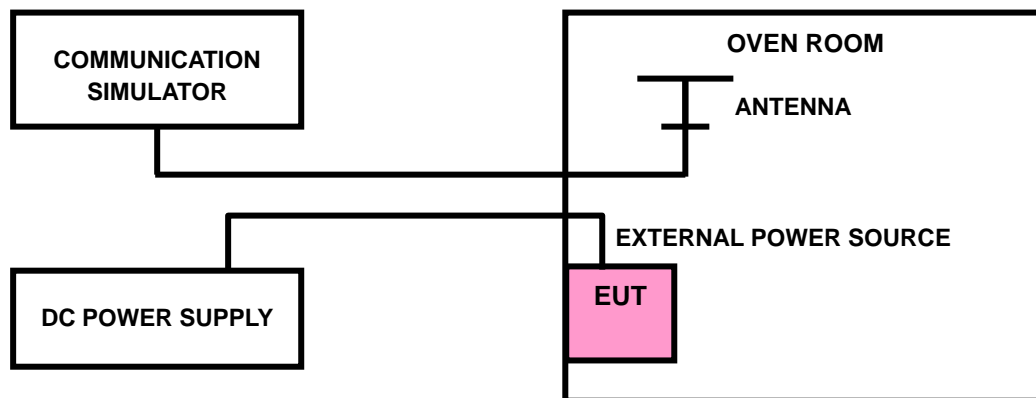



3.2.4 TEST RESULTS

GSM1900

FREQUENCY ERROR VS. VOLTAGE

VOLTAGE (Volts)	FREQUENCY ERROR (ppm)		LIMIT (ppm)
	Low Channel	High Channel	
V_{nor}	0.0009	0.0012	2.5
V_{min}	-0.0011	-0.0012	2.5
V_{max}	0.0009	0.0011	2.5

NOTE: The applicant defined the normal working voltage of the battery is from V_{min} to V_{max} .

FREQUENCY ERROR vs. TEMPERATURE.

TEMP. (°C)	FREQUENCY ERROR (ppm)		LIMIT (ppm)
	Low Channel	High Channel	
-30	-0.0055	-0.0053	2.5
-20	-0.0051	-0.0048	2.5
-10	-0.0046	-0.0044	2.5
0	-0.0037	-0.0035	2.5
10	-0.0030	-0.0028	2.5
20	-0.0022	-0.0020	2.5
30	-0.0017	-0.0015	2.5
40	-0.0014	-0.0012	2.5
50	-0.0004	-0.0002	2.5



EDGE 1900

FREQUENCY ERROR VS. VOLTAGE

VOLTAGE (Volts)	FREQUENCY ERROR (ppm)		LIMIT (ppm)
	Low Channel	High Channel	
V_{nor}	0.0012	0.0011	2.5
V_{min}	-0.0013	-0.0012	2.5
V_{max}	0.0010	0.0009	2.5

NOTE: The applicant defined the normal working voltage of the battery is from V_{min} to V_{max} .

FREQUENCY ERROR vs. TEMPERATURE.

TEMP. (°C)	FREQUENCY ERROR (ppm)		LIMIT (ppm)
	Low Channel	High Channel	
-30	-0.0057	-0.0053	2.5
-20	-0.0050	-0.0047	2.5
-10	-0.0045	-0.0043	2.5
0	-0.0038	-0.0036	2.5
10	-0.0029	-0.0027	2.5
20	-0.0024	-0.0022	2.5
30	-0.0017	-0.0016	2.5
40	-0.0012	-0.0011	2.5
50	-0.0005	-0.0004	2.5



WCDMA BAND II

FREQUENCY ERROR VS. VOLTAGE

VOLTAGE (Volts)	FREQUENCY ERROR (ppm)		LIMIT (ppm)
	Low Channel	High Channel	
V_{nor}	0.0009	0.0011	2.5
V_{min}	-0.0011	-0.0009	2.5
V_{max}	0.0011	0.0011	2.5

NOTE: The applicant defined the normal working voltage of the battery is from V_{min} to V_{max} .

FREQUENCY ERROR vs. TEMPERATURE.

TEMP. (°C)	FREQUENCY ERROR (ppm)		LIMIT (ppm)
	Low Channel	High Channel	
-30	-0.0050	-0.0052	2.5
-20	-0.0046	-0.0046	2.5
-10	-0.0038	-0.0037	2.5
0	-0.0033	-0.0034	2.5
10	-0.0023	-0.0020	2.5
20	-0.0018	-0.0017	2.5
30	-0.0015	-0.0018	2.5
40	-0.0008	-0.0010	2.5
50	-0.0002	-0.0002	2.5



LTE BAND 2

FREQUENCY ERROR VS. VOLTAGE

VOLTAGE (Volts)	1.4MHz		LIMIT (ppm)
	FREQUENCY ERROR (ppm)		
	Low Channel	High Channel	
V _{nor}	0.0022	0.0025	2.5
V _{min}	-0.0031	-0.0030	2.5
V _{max}	0.0021	0.0021	2.5

NOTE: The applicant defined the normal working voltage of the battery is from V_{min} to V_{max}.

FREQUENCY ERROR vs. TEMPERATURE.

TEMP. (°C)	1.4MHz		LIMIT (ppm)
	FREQUENCY ERROR (ppm)		
	Low Channel	High Channel	
-30	-0.0119	-0.0111	2.5
-20	-0.0100	-0.0109	2.5
-10	-0.0083	-0.0082	2.5
0	-0.0077	-0.0072	2.5
10	-0.0053	-0.0053	2.5
20	-0.0038	-0.0037	2.5
30	-0.0037	-0.0030	2.5
40	-0.0021	-0.0021	2.5
50	-0.0002	-0.0004	2.5



FREQUENCY ERROR VS. VOLTAGE

VOLTAGE (Volts)	3MHz		LIMIT (ppm)
	FREQUENCY ERROR (ppm)		
	Low Channel	High Channel	
V _{nor}	0.0022	0.0021	2.5
V _{min}	-0.0022	-0.0025	2.5
V _{max}	0.0018	0.0017	2.5

NOTE: The applicant defined the normal working voltage of the battery is from V_{min} to V_{max}.

FREQUENCY ERROR vs. TEMPERATURE.

TEMP. (°C)	3MHz		LIMIT (ppm)
	FREQUENCY ERROR (ppm)		
	Low Channel	High Channel	
-30	-0.0123	-0.0111	2.5
-20	-0.0110	-0.0103	2.5
-10	-0.0081	-0.0082	2.5
0	-0.0074	-0.0072	2.5
10	-0.0055	-0.0054	2.5
20	-0.0042	-0.0044	2.5
30	-0.0035	-0.0033	2.5
40	-0.0018	-0.0017	2.5
50	-0.0002	-0.0001	2.5



FREQUENCY ERROR VS. VOLTAGE

VOLTAGE (Volts)	5MHz		LIMIT (ppm)
	FREQUENCY ERROR (ppm)		
	Low Channel	High Channel	
V _{nor}	0.0022	0.0023	2.5
V _{min}	-0.0023	-0.0031	2.5
V _{max}	0.0021	0.0020	2.5

NOTE: The applicant defined the normal working voltage of the battery is from V_{min} to V_{max}.

FREQUENCY ERROR vs. TEMPERATURE.

TEMP. (°C)	5MHz		LIMIT (ppm)
	FREQUENCY ERROR (ppm)		
	Low Channel	High Channel	
-30	-0.0117	-0.0119	2.5
-20	-0.0104	-0.0105	2.5
-10	-0.0083	-0.0082	2.5
0	-0.0078	-0.0073	2.5
10	-0.0051	-0.0052	2.5
20	-0.0040	-0.0043	2.5
30	-0.0035	-0.0026	2.5
40	-0.0020	-0.0016	2.5
50	-0.0005	-0.0003	2.5



FREQUENCY ERROR VS. VOLTAGE

VOLTAGE (Volts)	10MHz		LIMIT (ppm)
	FREQUENCY ERROR (ppm)		
	Low Channel	High Channel	
V _{nor}	0.0024	0.0024	2.5
V _{min}	-0.0031	-0.0030	2.5
V _{max}	0.0026	0.0024	2.5

NOTE: The applicant defined the normal working voltage of the battery is from V_{min} to V_{max}.

FREQUENCY ERROR vs. TEMPERATURE.

TEMP. (°C)	10MHz		LIMIT (ppm)
	FREQUENCY ERROR (ppm)		
	Low Channel	High Channel	
-30	-0.0118	-0.0113	2.5
-20	-0.0107	-0.0108	2.5
-10	-0.0083	-0.0082	2.5
0	-0.0075	-0.0073	2.5
10	-0.0045	-0.0047	2.5
20	-0.0043	-0.0041	2.5
30	-0.0024	-0.0027	2.5
40	-0.0021	-0.0020	2.5
50	-0.0002	-0.0004	2.5



FREQUENCY ERROR VS. VOLTAGE

VOLTAGE (Volts)	15MHz		LIMIT (ppm)
	FREQUENCY ERROR (ppm)		
	Low Channel	High Channel	
V _{nor}	0.0025	0.0026	2.5
V _{min}	-0.0030	-0.0030	2.5
V _{max}	0.0026	0.0026	2.5

NOTE: The applicant defined the normal working voltage of the battery is from V_{min} to V_{max}.

FREQUENCY ERROR vs. TEMPERATURE.

TEMP. (°C)	15MHz		LIMIT (ppm)
	FREQUENCY ERROR (ppm)		
	Low Channel	High Channel	
-30	-0.0112	-0.0121	2.5
-20	-0.0099	-0.0102	2.5
-10	-0.0082	-0.0083	2.5
0	-0.0076	-0.0072	2.5
10	-0.0049	-0.0048	2.5
20	-0.0038	-0.0042	2.5
30	-0.0032	-0.0041	2.5
40	-0.0021	-0.0021	2.5
50	-0.0002	-0.0005	2.5



FREQUENCY ERROR VS. VOLTAGE

VOLTAGE (Volts)	20MHz		LIMIT (ppm)
	FREQUENCY ERROR (ppm)		
	Low Channel	High Channel	
V _{nor}	0.0025	0.0023	2.5
V _{min}	-0.0031	-0.0030	2.5
V _{max}	0.0024	0.0024	2.5

NOTE: The applicant defined the normal working voltage of the battery is from V_{min} to V_{max}.

FREQUENCY ERROR vs. TEMPERATURE.

TEMP. (°C)	20MHz		LIMIT (ppm)
	FREQUENCY ERROR (ppm)		
	Low Channel	High Channel	
-30	-0.0120	-0.0119	2.5
-20	-0.0103	-0.0097	2.5
-10	-0.0081	-0.0083	2.5
0	-0.0075	-0.0073	2.5
10	-0.0056	-0.0052	2.5
20	-0.0039	-0.0039	2.5
30	-0.0036	-0.0041	2.5
40	-0.0015	-0.0014	2.5
50	-0.0004	-0.0006	2.5



3.3 OCCUPIED BANDWIDTH MEASUREMENT

3.3.1 TEST PROCEDURES

The EUT makes a call to the communication simulator. All measurements were done at low, middle and high operational frequency range. The communication simulator station system controlled a EUT to export maximum output power under transmission mode and specific channel frequency. Use OBW measurement function of Spectrum analyzer to measure 99 % occupied bandwidth.

3.3.2 TEST SETUP

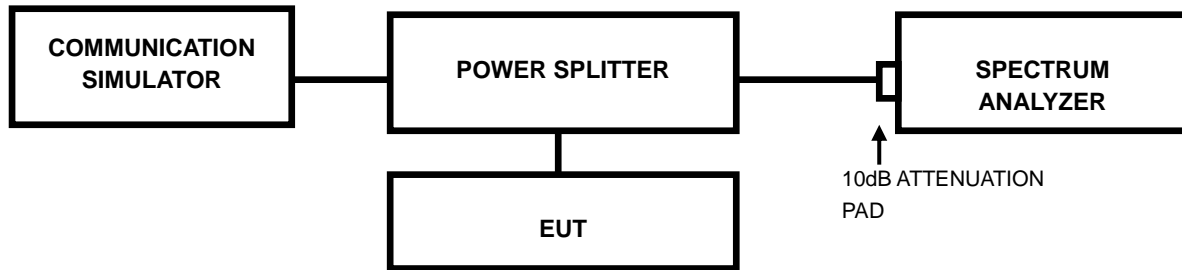



3.3.3 TEST RESULTS

Channel	Frequency (MHz)	99% Occupied bandwidth (kHz)		Channel	Frequency (MHz)	99% Occupied bandwidth (MHz)
		GSM	EDGE			WCDMA
512	1850.2	243.730	245.970	9262	1852.4	4.156
661	1880.0	243.540	241.260	9400	1880.0	4.148
810	1909.8	245.420	244.910	9538	1907.6	4.160
Channel	Frequency (MHz)	26dB bandwidth (kHz)		CHANNEL	FREQUENCY (MHz)	26dB bandwidth (MHz)
		GSM	EDGE			WCDMA
512	1850.2	316.600	317.900	9262	1852.4	4.734
661	1880.0	312.100	315.000	9400	1880.0	4.741
810	1909.8	320.000	312.000	9538	1907.6	4.754

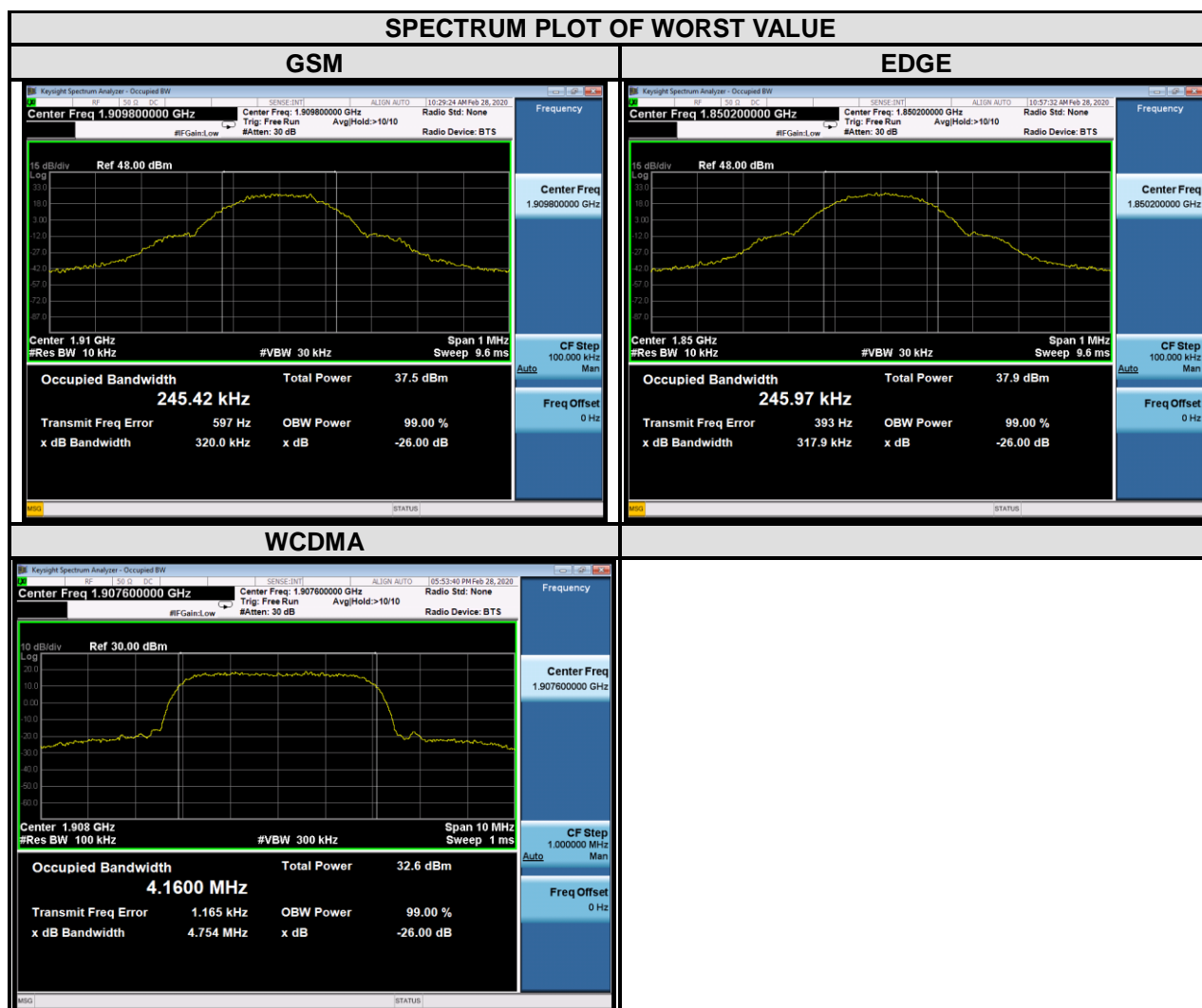



**BUREAU
VERITAS**

Test Report No.: RF200106W008-5

LTE band 2				
Channel Bandwidth : 1.4MHz				
Channel	Frequency (MHz)	99% Occupied bandwidth (MHz)		
		QPSK	16QAM	64QAM
18607	1850.7	1.09	1.09	1.09
18900	1880	1.08	1.08	1.08
19193	1909.3	1.08	1.09	1.08
CHANNEL	Frequency (MHz)	26 dB bandwidth (MHz)		
		QPSK	16QAM	64QAM
18607	1850.7	1.22	1.23	1.22
18900	1880	1.23	1.22	1.21
19193	1909.3	1.23	1.23	1.24





**BUREAU
VERITAS**

Test Report No.: RF200106W008-5

LTE band 2				
Channel Bandwidth : 3MHz				
Channel	Frequency (MHz)	99% Occupied bandwidth (MHz)		
		QPSK	16QAM	64QAM
18615	1851.5	2.69	2.68	2.68
18900	1880	2.69	2.68	2.68
19185	1908.5	2.69	2.68	2.68
CHANNEL	Frequency (MHz)	26 dB bandwidth (MHz)		
		QPSK	16QAM	64QAM
18615	1851.5	2.94	2.94	2.95
18900	1880	2.95	2.96	2.97
19185	1908.5	2.95	2.95	2.95

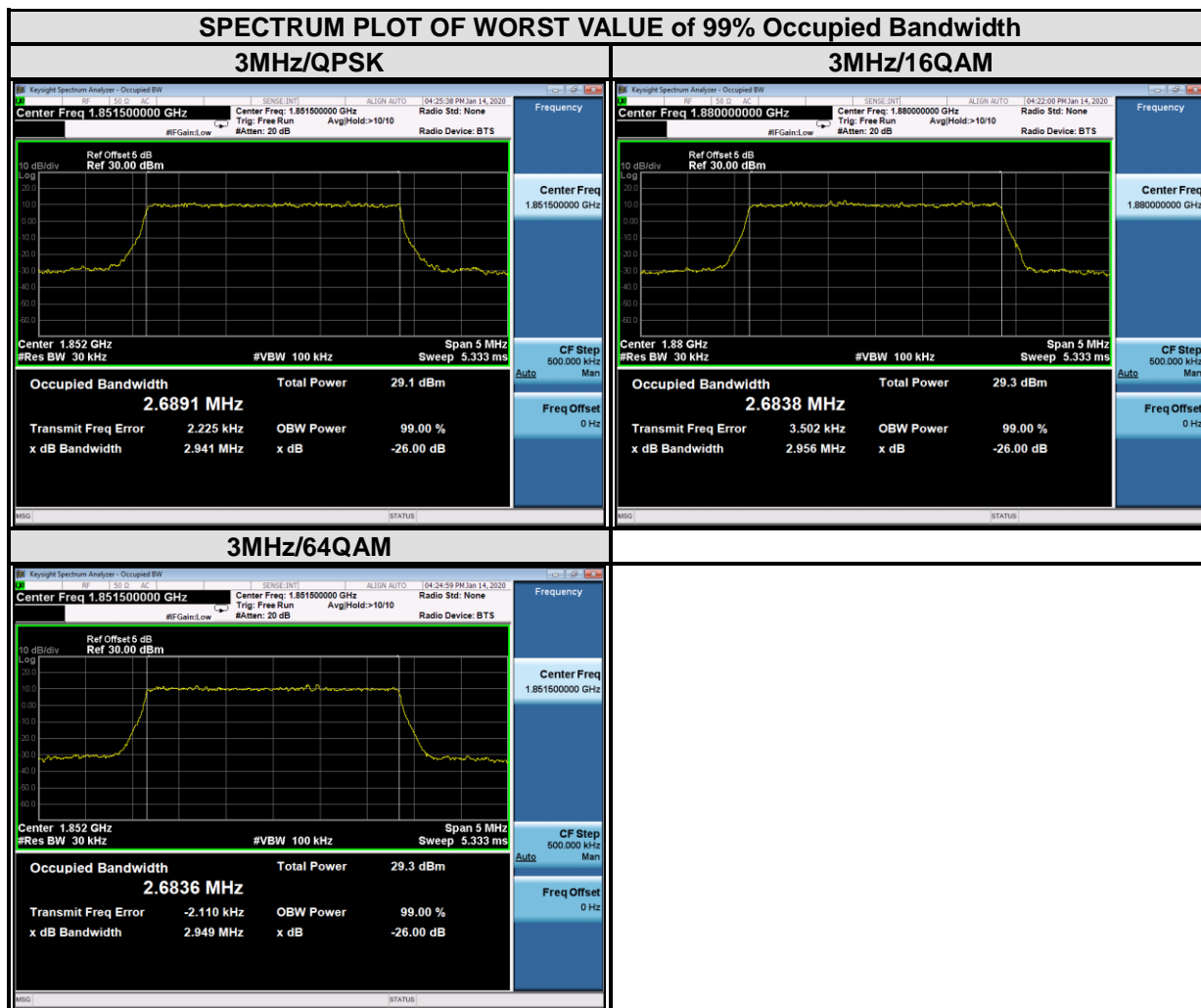



LTE band 2				
Channel Bandwidth : 5MHz				
Channel	Frequency (MHz)	99% Occupied bandwidth (MHz)		
		QPSK	16QAM	64QAM
18625	1852.5	4.47	4.49	4.47
18900	1880	4.49	4.48	4.47
19175	1907.5	4.47	4.47	4.47
CHANNEL	Frequency (MHz)	26 dB bandwidth (MHz)		
		QPSK	16QAM	64QAM
18625	1852.5	4.84	4.91	4.88
18900	1880	4.91	4.88	4.84
19175	1907.5	4.89	4.92	4.92





LTE band 2				
Channel Bandwidth : 10MHz				
Channel	Frequency (MHz)	99% Occupied bandwidth (MHz)		
		QPSK	16QAM	64QAM
18650	1855	8.94	8.96	8.96
18900	1880	8.96	8.95	8.95
19150	1905	8.94	8.96	8.95
CHANNEL	Frequency (MHz)	26 dB bandwidth (MHz)		
		QPSK	16QAM	64QAM
18650	1855	9.75	9.63	9.58
18900	1880	9.76	9.69	9.66
19150	1905	9.64	9.69	9.58





LTE band 2				
Channel Bandwidth : 15MHz				
Channel	Frequency (MHz)	99% Occupied bandwidth (MHz)		
		QPSK	16QAM	64QAM
18675	1857.5	13.39	13.37	13.35
18900	1880	13.40	13.38	13.37
19125	1902.5	13.40	13.41	13.41
CHANNEL	Frequency (MHz)	26 dB bandwidth (MHz)		
		QPSK	16QAM	64QAM
18675	1857.5	14.39	14.34	14.28
18900	1880	14.44	14.36	14.39
19125	1902.5	14.53	14.30	14.49

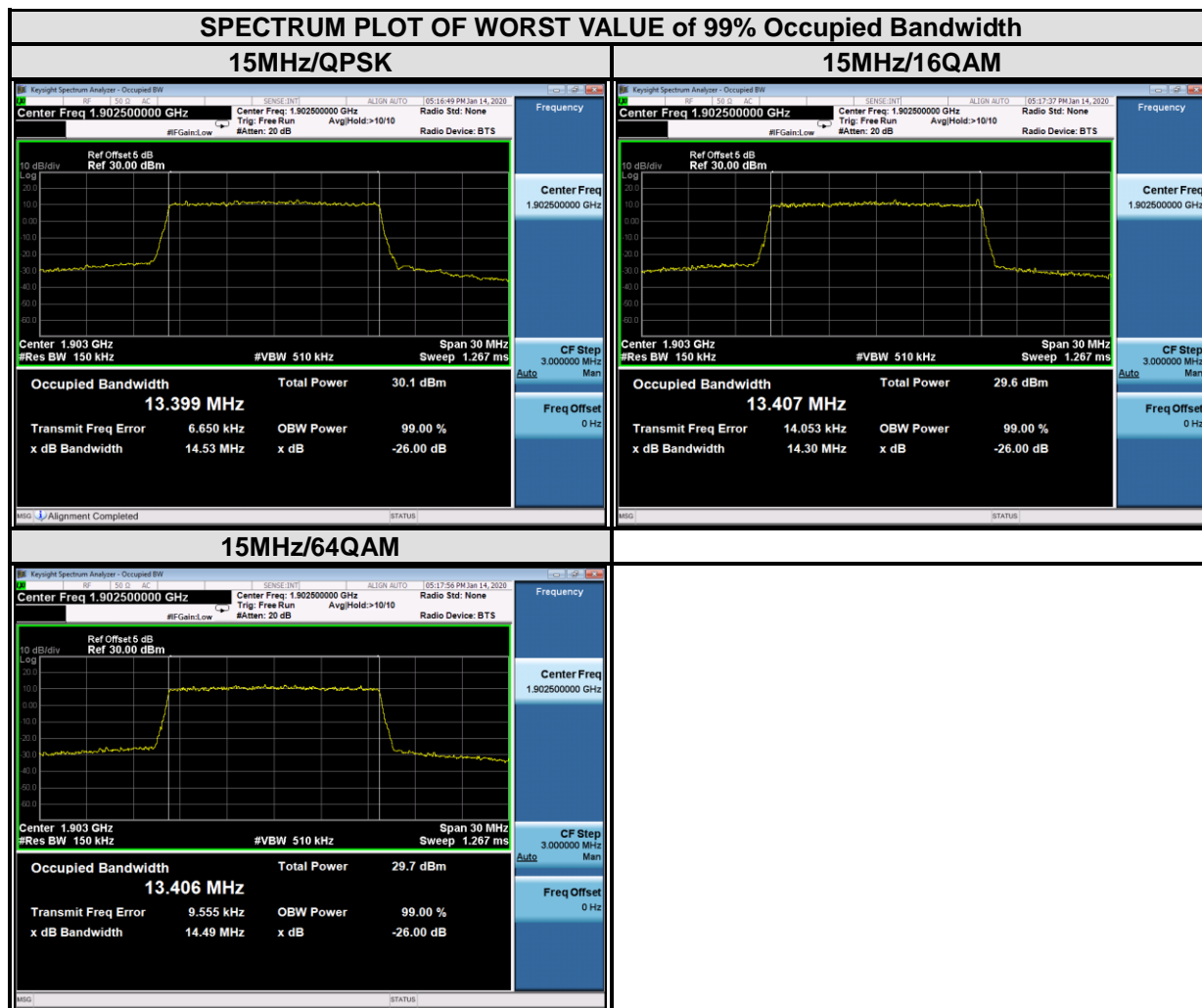



LTE band 2				
Channel Bandwidth : 20MHz				
Channel	Frequency (MHz)	99% Occupied bandwidth (MHz)		
		QPSK	16QAM	64QAM
18700	1860	17.88	17.91	17.94
18900	1880	17.87	17.91	17.90
19100	1900	17.94	17.95	17.97
CHANNEL	Frequency (MHz)	26 dB bandwidth (MHz)		
		QPSK	16QAM	64QAM
18700	1860	19.08	19.37	19.26
18900	1880	19.12	19.24	19.25
19100	1900	19.33	19.29	19.26

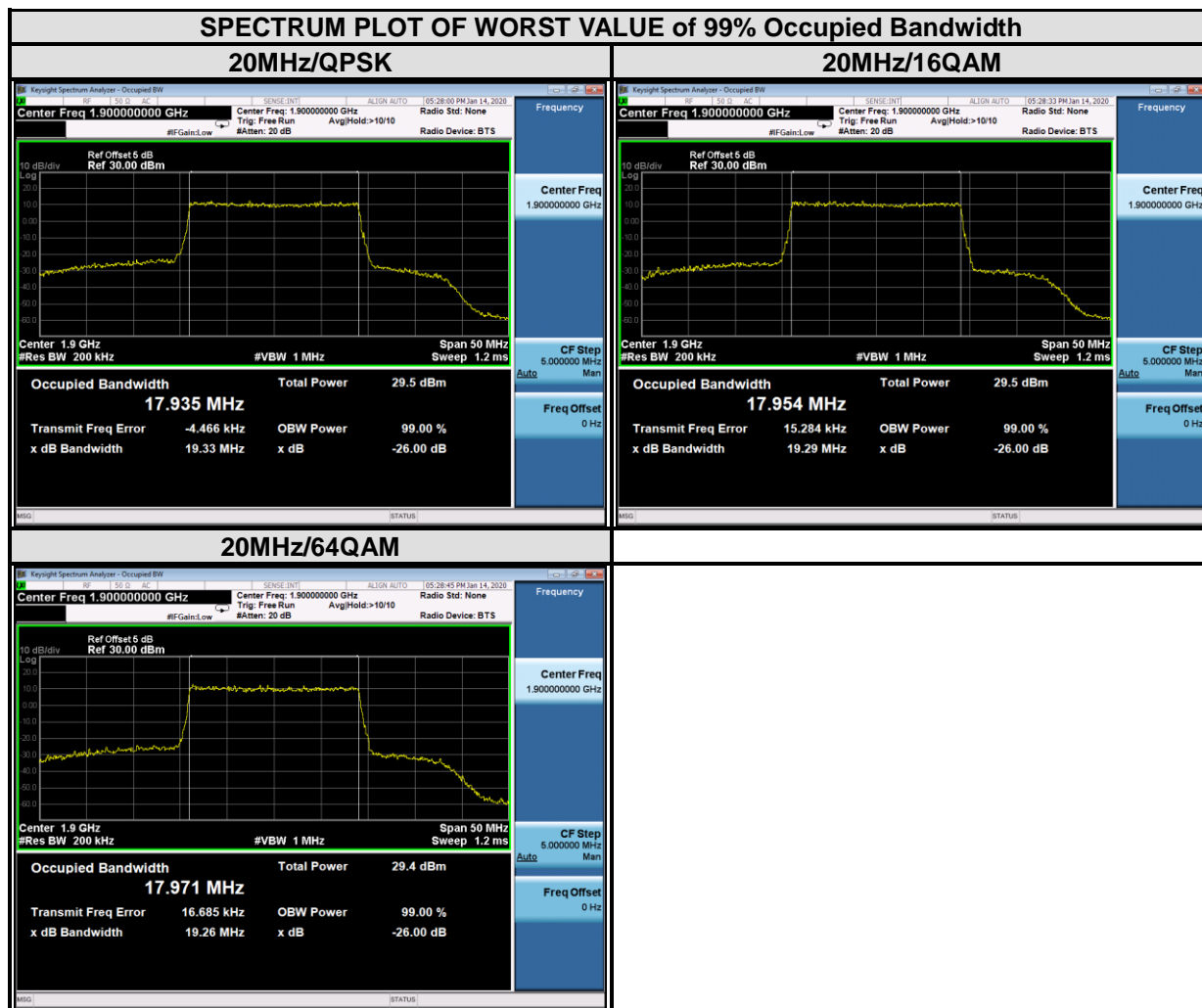



3.4 BAND EDGE MEASUREMENT

3.4.1 LIMITS OF BAND EDGE MEASUREMENT

Power of any emission outside of the authorized operating frequency ranges must be attenuated below the transmitting power (P) by a factor of at least $43 + 10 \log(P)$ dB. In the 1 MHz bands immediately outside and adjacent to the frequency block a resolution bandwidth of at least one percent of the emission bandwidth of the fundamental emission of the transmitter may be employed.

3.4.2 TEST SETUP

