

# FCC SAR Test Report

**Report No.** : SA190719C19  
**Applicant** : Xiaomi Communications Co., Ltd.  
**Address** : The Rainbow City of China Resources,NO.68,Qinghe Middle Street,Haidian District,Beijing,China  
**Product** : Mobile Phone  
**FCC ID** : 2AFZZF3BG  
**Brand** : XIAOMI  
**Model No.** : M1904F3BG  
**Standards** : FCC 47 CFR Part 2 (2.1093), IEEE C95.1:1992, IEEE Std 1528:2013  
 KDB 865664 D01 v01r04, KDB 865664 D02 v01r02, KDB 248227 D01 v02r02,  
 KDB 447498 D01 v06, KDB 648474 D04 v01r03, KDB 941225 D01 v03r01,  
 KDB 941225 D05 v02r05, KDB 941225 D05A v01r02, KDB 941225 D06 v02r01  
**Sample Received Date** : Jul. 19, 2019  
**Date of Testing** : Jul. 24, 2019 ~ Aug. 08, 2019  
**Lab Address** : No. 47-2, 14th Ling, Chia Pau Vil., Lin Kou Dist.,New Taipei City, Taiwan, R.O.C.  
**Test Location** : No. 19, Hwa Ya 2nd Rd, Wen Hwa Vil, Kwei Shan Dist., Taoyuan City 33383, Taiwan (R.O.C)

**CERTIFICATION:** The above equipment have been tested by **Bureau Veritas Consumer Products Services (H.K.) Ltd., Taoyuan Branch–Lin Kou Laboratories**, and found compliance with the requirement of the above standards. The test record, data evaluation & Equipment Under Test (EUT) configurations represented herein are true and accurate accounts of the measurements of the sample’s SAR characteristics under the conditions specified in this report. It should not be reproduced except in full, without the written approval of our laboratory. The client should not use it to claim product certification, approval, or endorsement by TAF or any government agencies.

**Prepared By :** Rona Chen  
 Rona Chen / Specialist  
**Approved By :** Gordon Lin  
 Gordon Lin / Manager



This report is for your exclusive use. Any copying or replication of this report to or for any other person or entity, or use of our name or trademark, is permitted only with our prior written permission. This report sets forth our findings solely with respect to the test samples identified herein. The results set forth in this report are not indicative or representative of the quality or characteristics of the lot from which a test sample was taken or any similar or identical product unless specifically and expressly noted. Our report includes all of the tests requested by you and the results thereof based upon the information that you provided to us. You have 60 days from date of issuance of this report to notify us of any material error or omission caused by our negligence, provided, however, that such notice shall be in writing and shall specifically address the issue you wish to raise. A failure to raise such issue within the prescribed time shall constitute your unqualified acceptance of the completeness of this report, the tests conducted and the correctness of the report contents. Unless specific mention, the uncertainty of measurement has been explicitly taken into account to declare the compliance or non-compliance to the specification.

## Table of Contents

Release Control Record .....	3
1. Summary of Maximum SAR Value .....	4
2. Description of Equipment Under Test .....	5
3. SAR Measurement System .....	7
3.1 Definition of Specific Absorption Rate (SAR) .....	7
3.2 SPEAG DASY6 System .....	7
3.2.1 Robot .....	8
3.2.2 Probes .....	9
3.2.3 Data Acquisition Electronics (DAE) .....	9
3.2.4 Phantoms .....	9
3.2.5 Device Holder .....	10
3.2.6 System Validation Dipoles .....	10
3.2.7 Tissue Simulating Liquids .....	11
3.3 SAR System Verification .....	13
3.4 SAR Measurement Procedure .....	14
3.4.1 Area & Zoom Scan Procedure .....	14
3.4.2 Volume Scan Procedure .....	14
3.4.3 Power Drift Monitoring .....	15
3.4.4 Spatial Peak SAR Evaluation .....	15
3.4.5 SAR Averaged Methods .....	15
4. SAR Measurement Evaluation .....	16
4.1 EUT Configuration and Setting .....	16
4.2 EUT Testing Position .....	28
4.2.1 Head Exposure Conditions .....	28
4.2.2 Body-worn Accessory Exposure Conditions .....	30
4.2.3 Hotspot Mode Exposure Conditions .....	31
4.2.4 Product Specific (Phablet) Exposure Conditions .....	32
4.3 Tissue Verification .....	33
4.4 System Validation .....	34
4.5 System Verification .....	35
4.6 Maximum Output Power .....	37
4.6.1 Maximum Target Conducted Power .....	37
4.6.2 Measured Conducted Power Result .....	44
4.7 SAR Testing Results .....	72
4.7.1 SAR Test Reduction Considerations .....	72
4.7.2 SAR Results for Head Exposure Condition .....	77
4.7.3 SAR Results for Body-worn Exposure Condition (Test Separation Distance is 15 mm) .....	83
4.7.4 SAR Results for Hotspot Exposure Condition (Test Separation Distance is 10 mm) .....	87
4.7.5 SAR Results for Product Specific (Phablet) Exposure Condition (Test Separation Distance is 0 mm) .....	92
4.7.6 SAR Measurement Variability .....	94
4.7.7 Simultaneous Multi-band Transmission Evaluation .....	95
5. Calibration of Test Equipment .....	100
6. Measurement Uncertainty .....	101
7. Information of the Testing Laboratories .....	102
Appendix A. SAR Plots of System Verification	
Appendix B. SAR Plots of SAR Measurement	
Appendix C. Calibration Certificate for Probe and Dipole	
Appendix D. Photographs of EUT and Setup	



### 1. Summary of Maximum SAR Value

Equipment Class	Mode	Highest SAR-1g Head (W/kg)	Highest SAR-1g Body-worn Tested at 15 mm (W/kg)	Highest SAR-1g Hotspot Tested at 10 mm (W/kg)	Highest SAR-10g Product Specific Tested at 0 mm (W/kg)
PCE	GSM850	0.69	0.13	0.27	N/A
	GSM1900	0.93	0.49	1.11	1.76
	WCDMA II	1.19	1.15	0.94	3.15
	WCDMA IV	1.14	0.72	0.75	3.11
	WCDMA V	0.88	0.15	0.32	N/A
	LTE 2	0.87	1.04	0.87	2.30
	LTE 4	0.95	0.78	0.87	2.89
	LTE 5	0.82	0.12	0.23	N/A
	LTE 7	1.01	0.88	1.08	3.02
LTE 38	1.19	0.42	1.01	N/A	
DTS	2.4G WLAN	1.19	0.16	0.69	N/A
NII	5.2G WLAN	N/A	N/A	0.22	N/A
	5.3G WLAN	0.11	0.03	N/A	0.81
	5.6G WLAN	0.21	0.02	N/A	1.58
	5.8G WLAN	0.17	0.01	0.33	N/A
DSS	Bluetooth	0.07	0.00	0.01	N/A
DXX	NFC	N/A	N/A	N/A	N/A

Highest Simultaneous Transmission SAR	Highest SAR-1g Head (W/kg)	Highest SAR-1g Body-worn Tested at 15 mm (W/kg)	Highest SAR-1g Hotspot Tested at 10 mm (W/kg)	Highest SAR-10g Product Specific Tested at 0 mm (W/kg)
	1.55	1.29	1.11	3.31

**Note:**

- The SAR criteria (**Head & Body: SAR-1g 1.6 W/kg, and Extremity: SAR-10g 4.0 W/kg**) for general population/uncontrolled exposure is specified in FCC 47 CFR part 2 (2.1093) and ANSI/IEEE C95.1-1992.

## 2. Description of Equipment Under Test

<b>EUT Type</b>	Mobile Phone
<b>FCC ID</b>	2AFZZF3BG
<b>Brand Name</b>	XIAOMI
<b>Model Name</b>	M1904F3BG
<b>Tx Frequency Bands (Unit: MHz)</b>	GSM850 : 824.2 ~ 848.8 GSM1900 : 1850.2 ~ 1909.8 WCDMA Band II : 1852.4 ~ 1907.6 WCDMA Band IV : 1712.4 ~ 1752.6 WCDMA Band V : 826.4 ~ 846.6 LTE Band 2 : 1850.7 ~ 1909.3 (BW: 1.4M, 3M, 5M, 10M, 15M, 20M) LTE Band 4 : 1710.7 ~ 1754.3 (BW: 1.4M, 3M, 5M, 10M, 15M, 20M) LTE Band 5 : 824.7 ~ 848.3 (BW: 1.4M, 3M, 5M, 10M) LTE Band 7 : 2502.5 ~ 2567.5 (BW: 5M, 10M, 15M, 20M) LTE Band 38 : 2572.5 ~ 2617.5 (BW: 5M, 10M, 15M, 20M) WLAN : 2412 ~ 2462, 5180 ~ 5240, 5260 ~ 5320, 5500 ~ 5700, 5745 ~ 5825 Bluetooth : 2402 ~ 2480 NFC : 13.56
<b>Uplink Modulations</b>	GSM & GPRS : GMSK EDGE : 8PSK WCDMA : QPSK LTE : QPSK, 16QAM, 64QAM 802.11b : DSSS 802.11a/g/n/ac : OFDM Bluetooth : GFSK, $\pi/4$ -DQPSK, 8-DPSK NFC : ASK
<b>Maximum Tune-up Conducted Power (Unit: dBm)</b>	Please refer to section 4.6.1 of this report
<b>Antenna Type</b>	Fixed Internal Antenna
<b>EUT Stage</b>	Identical Prototype

**Note:**

- The above EUT information is declared by manufacturer and for more detailed features description please refers to the manufacturer's specifications or User's Manual.

**WWAN scenarios:**

Power Table	Test Scenario	Receiver	Hotspot	SAR P-sensor	WIFI State
Power Table-1	Standalone Head	On	Off	NA	Off
Power Table-2	Combine Head	On	Off	NA	On
Power Table-3	Standalone Body-Worn-15mm	Off	Off	On	Off
Power Table-4	Combine Body-Worn-15mm	Off	Off	On	On
Power Table-5	Standalone extremity limb	Off	Off	On	Off
Power Table-6	Combine extremity limb	Off	Off	On	On
Power Table-7	Hotspot	NA	On	NA	NA

# FCC SAR Test Report

## WLAN scenarios:

Power Table	Test Scenario	Receiver	Hotspot	SAR P-sensor	WWAN
Power Table-1	Standalone Head	On	NA	NA	Off
	Standalone Body-Worn-15mm	Off	Off	On	Off
	Standalone extremity limb	Off	Off	On	Off
Power Table-2	Combine Head	On	NA	NA	On
Power Table-3	Combine Body-Worn-15mm	Off	Off	On	On
Power Table-4	Combine extremity limb	Off	Off	On	On
Power Table-5	Hotspot	Off	On	On	NA

## List of Accessory:

Battery	Brand Name	MI
	Model Name	BM4F
	Power Rating	3.85 Vdc, 4030 mAh
	Type	Li-ion
Earphone	Brand Name	MI
	Model Name	EM023
	Signal Line Type	1.25 meter non-shielded cable without ferrite core

### **3. SAR Measurement System**

#### **3.1 Definition of Specific Absorption Rate (SAR)**

SAR is related to the rate at which energy is absorbed per unit mass in an object exposed to a radio field. The SAR distribution in a biological body is complicated and is usually carried out by experimental techniques or numerical modeling. The standard recommends limits for two tiers of groups, occupational/controlled and general population/uncontrolled, based on a person's awareness and ability to exercise control over his or her exposure. In general, occupational/controlled exposure limits are higher than the limits for general population/uncontrolled.

The SAR definition is the time derivative (rate) of the incremental energy (dW) absorbed by (dissipated in) an incremental mass (dm) contained in a volume element (dv) of a given density ( $\rho$ ). The equation description is as below:

$$\text{SAR} = \frac{d}{dt} \left( \frac{dW}{dm} \right) = \frac{d}{dt} \left( \frac{dW}{\rho dv} \right)$$

SAR is expressed in units of Watts per kilogram (W/kg)

SAR measurement can be related to the electrical field in the tissue by

$$\text{SAR} = \frac{\sigma |E|^2}{\rho}$$

Where:  $\sigma$  is the conductivity of the tissue,  $\rho$  is the mass density of the tissue and E is the RMS electrical field strength.

#### **3.2 SPEAG DASY6 System**

DASY6 system consists of high precision robot, probe alignment sensor, phantom, robot controller, controlled measurement server and near-field probe. The robot includes six axes that can move to the precision position of the DASY6 software defined. The DASY6 software can define the area that is detected by the probe. The robot is connected to controlled box. Controlled measurement server is connected to the controlled robot box. The DAE includes amplifier, signal multiplexing, AD converter, offset measurement and surface detection. It is connected to the Electro-optical coupler (ECO). The ECO performs the conversion from the optical into digital electric signal of the DAE and transfers data to the PC.

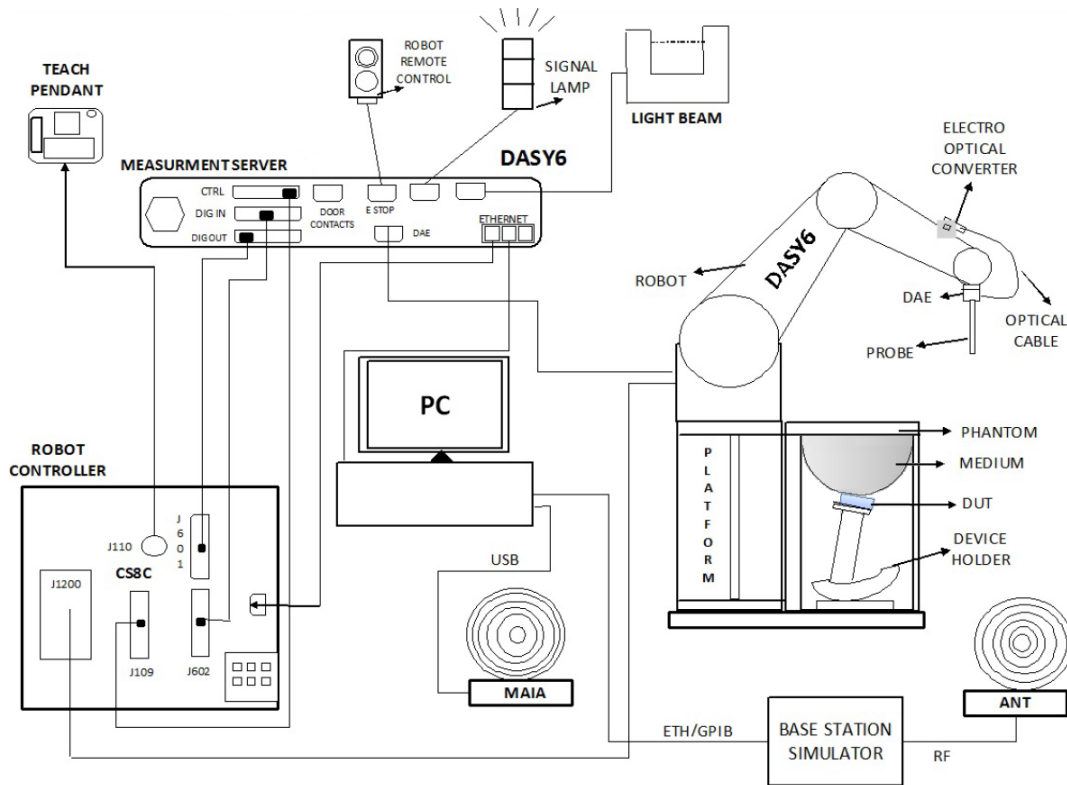

Fig-3.1 SPEAG DASY6 System Setup

### 3.2.1 Robot

The DASY6 systems use the high precision robots from Stäubli SA (France). For the 6-axis controller system, the robot controller version of CS8c from Stäubli is used. The Stäubli robot series have many features that are important for our application:

- High precision (repeatability  $\pm 0.035$  mm)
- High reliability (industrial design)
- Jerk-free straight movements
- Low ELF interference (the closed metallic construction shields against motor control fields)



Fig-3.2 SPEAG DASY6 System



## FCC SAR Test Report

### 3.2.2 Probes

The SAR measurement is conducted with the dosimetric probe. The probe is specially designed and calibrated for use in liquid with high permittivity. The dosimetric probe has special calibration in liquid at different frequency.

<b>Model</b>	EX3DV4	
<b>Construction</b>	Symmetrical design with triangular core. Built-in shielding against static charges. PEEK enclosure material (resistant to organic solvents, e.g., DGBE).	
<b>Frequency</b>	4 MHz to 10 GHz Linearity: $\pm 0.2$ dB	
<b>Directivity</b>	$\pm 0.1$ dB in TSL (rotation around probe axis) $\pm 0.3$ dB in TSL (rotation normal to probe axis)	
<b>Dynamic Range</b>	10 $\mu$ W/g to 100 mW/g Linearity: $\pm 0.2$ dB (noise: typically $< 1$ $\mu$ W/g)	
<b>Dimensions</b>	Overall length: 337 mm (Tip: 20 mm) Tip diameter: 2.5 mm (Body: 12 mm) Typical distance from probe tip to dipole centers: 1 mm	

### 3.2.3 Data Acquisition Electronics (DAE)

<b>Model</b>	DAE3, DAE4	
<b>Construction</b>	Signal amplifier, multiplexer, A/D converter and control logic. Serial optical link for communication with DASY embedded system (fully remote controlled). Two step probe touch detector for mechanical surface detection and emergency robot stop.	
<b>Measurement Range</b>	-100 to +300 mV (16 bit resolution and two range settings: 4mV, 400mV)	
<b>Input Offset Voltage</b>	$< 5$ $\mu$ V (with auto zero)	
<b>Input Bias Current</b>	$< 50$ fA	
<b>Dimensions</b>	60 x 60 x 68 mm	

### 3.2.4 Phantoms

<b>Model</b>	Twin SAM	
<b>Construction</b>	The shell corresponds to the specifications of the Specific Anthropomorphic Mannequin (SAM) phantom defined in IEEE 1528 and IEC 62209-1. It enables the dosimetric evaluation of left and right hand phone usage as well as body mounted usage at the flat phantom region. A cover prevents evaporation of the liquid. Reference markings on the phantom allow the complete setup of all predefined phantom positions and measurement grids by teaching three points with the robot.	
<b>Material</b>	Vinylester, glass fiber reinforced (VE-GF)	
<b>Shell Thickness</b>	2 $\pm$ 0.2 mm (6 $\pm$ 0.2 mm at ear point)	
<b>Dimensions</b>	Length: 1000 mm Width: 500 mm Height: adjustable feet	
<b>Filling Volume</b>	approx. 25 liters	

# FCC SAR Test Report

<b>Model</b>	ELI	
<b>Construction</b>	Phantom for compliance testing of handheld and body-mounted wireless devices in the frequency range of 30 MHz to 6 GHz. ELI is fully compatible with the IEC 62209-2 standard and all known tissue simulating liquids. ELI has been optimized regarding its performance and can be integrated into our standard phantom tables. A cover prevents evaporation of the liquid. Reference markings on the phantom allow installation of the complete setup, including all predefined phantom positions and measurement grids, by teaching three points. The phantom is compatible with all SPEAG dosimetric probes and dipoles.	
<b>Material</b>	Vinylester, glass fiber reinforced (VE-GF)	
<b>Shell Thickness</b>	2.0 ± 0.2 mm (bottom plate)	
<b>Dimensions</b>	Major axis: 600 mm Minor axis: 400 mm	
<b>Filling Volume</b>	approx. 30 liters	

### 3.2.5 Device Holder

<b>Model</b>	Mounting Device	
<b>Construction</b>	In combination with the Twin SAM Phantom or ELI4, the Mounting Device enables the rotation of the mounted transmitter device in spherical coordinates. Rotation point is the ear opening point. Transmitter devices can be easily and accurately positioned according to IEC, IEEE, FCC or other specifications. The device holder can be locked for positioning at different phantom sections (left head, right head, flat).	
<b>Material</b>	POM	

<b>Model</b>	Laptop Extensions Kit	
<b>Construction</b>	Simple but effective and easy-to-use extension for Mounting Device that facilitates the testing of larger devices according to IEC 62209-2 (e.g., laptops, cameras, etc.). It is lightweight and fits easily on the upper part of the Mounting Device in place of the phone positioner.	
<b>Material</b>	POM, Acrylic glass, Foam	

### 3.2.6 System Validation Dipoles

<b>Model</b>	D-Serial	
<b>Construction</b>	Symmetrical dipole with 1/4 balun. Enables measurement of feedpoint impedance with NWA. Matched for use near flat phantoms filled with tissue simulating solutions.	
<b>Frequency</b>	750 MHz to 5800 MHz	
<b>Return Loss</b>	> 20 dB	
<b>Power Capability</b>	> 100 W (f < 1GHz), > 40 W (f > 1GHz)	

**3.2.7 Tissue Simulating Liquids**

For SAR measurement of the field distribution inside the phantom, the phantom must be filled with homogeneous tissue simulating liquid to a depth of at least 15 cm. For head SAR testing, the liquid height from the ear reference point (ERP) of the phantom to the liquid top surface is larger than 15 cm. For body SAR testing, the liquid height from the center of the flat phantom to the liquid top surface is larger than 15 cm. The nominal dielectric values of the tissue simulating liquids in the phantom and the tolerance of 5% are listed in Table-3.1.

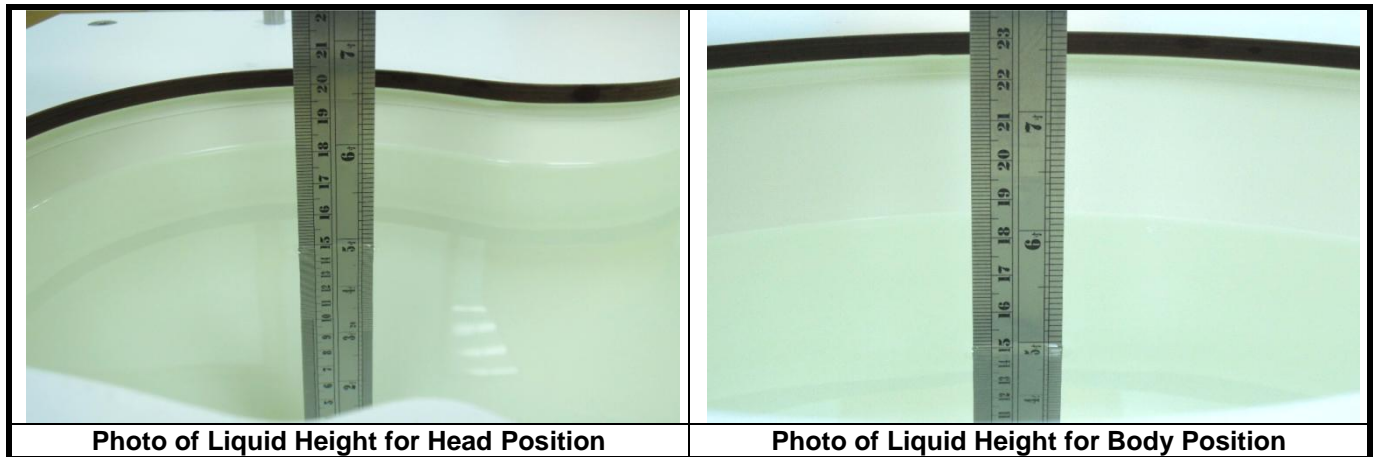

The dielectric properties of the head tissue simulating liquids are defined in IEEE1528, and KDB 865664 D01 Appendix A. For the body tissue simulating liquids, the dielectric properties are defined in KDB 865664 D01 Appendix A. The dielectric properties of the tissue simulating liquids were verified prior to the SAR evaluation using a dielectric assessment kit and a network analyzer.

## FCC SAR Test Report

**Table-3.1 Targets of Tissue Simulating Liquid**

Frequency (MHz)	Target Permittivity	Range of $\pm 5\%$	Target Conductivity	Range of $\pm 5\%$
750	41.9	39.8 ~ 44.0	0.89	0.85 ~ 0.93
835	41.5	39.4 ~ 43.6	0.90	0.86 ~ 0.95
900	41.5	39.4 ~ 43.6	0.97	0.92 ~ 1.02
1450	40.5	38.5 ~ 42.5	1.20	1.14 ~ 1.26
1640	40.3	38.3 ~ 42.3	1.29	1.23 ~ 1.35
1750	40.1	38.1 ~ 42.1	1.37	1.30 ~ 1.44
1800	40.0	38.0 ~ 42.0	1.40	1.33 ~ 1.47
1900	40.0	38.0 ~ 42.0	1.40	1.33 ~ 1.47
2000	40.0	38.0 ~ 42.0	1.40	1.33 ~ 1.47
2300	39.5	37.5 ~ 41.5	1.67	1.59 ~ 1.75
2450	39.2	37.2 ~ 41.2	1.80	1.71 ~ 1.89
2600	39.0	37.1 ~ 41.0	1.96	1.86 ~ 2.06
3500	37.9	36.0 ~ 39.8	2.91	2.76 ~ 3.06
5200	36.0	34.2 ~ 37.8	4.66	4.43 ~ 4.89
5300	35.9	34.1 ~ 37.7	4.76	4.52 ~ 5.00
5500	35.6	33.8 ~ 37.4	4.96	4.71 ~ 5.21
5600	35.5	33.7 ~ 37.3	5.07	4.82 ~ 5.32
5800	35.3	33.5 ~ 37.1	5.27	5.01 ~ 5.53

The following table gives the recipes for tissue simulating liquids.

**Table-3.2 Recipes of Tissue Simulating Liquid**

Tissue Type	Bactericide	DGBE	HEC	NaCl	Sucrose	Triton X-100	Water	Diethylene Glycol Mono-hexylether
H750	0.2	-	0.2	1.5	56.0	-	42.1	-
H835	0.2	-	0.2	1.5	57.0	-	41.1	-
H900	0.2	-	0.2	1.4	58.0	-	40.2	-
H1450	-	43.3	-	0.6	-	-	56.1	-
H1640	-	45.8	-	0.5	-	-	53.7	-
H1750	-	47.0	-	0.4	-	-	52.6	-
H1800	-	44.5	-	0.3	-	-	55.2	-
H1900	-	44.5	-	0.2	-	-	55.3	-
H2000	-	44.5	-	0.1	-	-	55.4	-
H2300	-	44.9	-	0.1	-	-	55.0	-
H2450	-	45.0	-	0.1	-	-	54.9	-
H2600	-	45.1	-	0.1	-	-	54.8	-
H3500	-	8.0	-	0.2	-	20.0	71.8	-
H5G	-	-	-	-	-	17.2	65.5	17.3

### **3.3 SAR System Verification**

The system check verifies that the system operates within its specifications. It is performed daily or before every SAR measurement. The system check uses normal SAR measurements in the flat section of the phantom with a matched dipole at a specified distance. The system verification setup is shown as below.

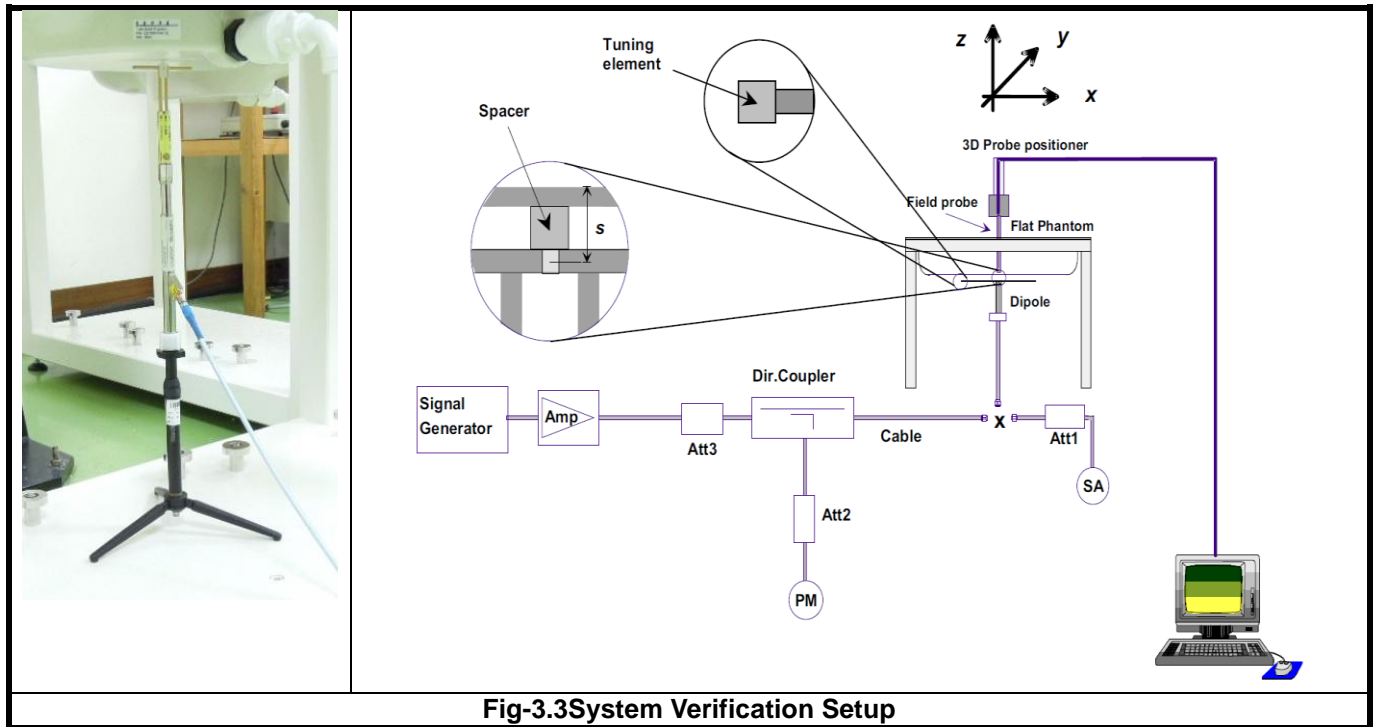

**Fig-3.3 System Verification Setup**

The validation dipole is placed beneath the flat phantom with the specific spacer in place. The distance spacer is touch the phantom surface with a light pressure at the reference marking and be oriented parallel to the long side of the phantom. The spectrum analyzer measures the forward power at the location of the system check dipole connector. The signal generator is adjusted for the desired forward power (250 mW is used for 700 MHz to 3 GHz, 100 mW is used for 3.5 GHz to 6 GHz) at the dipole connector and the power meter is read at that level. After connecting the cable to the dipole, the signal generator is readjusted for the same reading at power meter.

After system check testing, the SAR result will be normalized to 1W forward input power and compared with the reference SAR value derived from validation dipole certificate report. The deviation of system check should be within 10 %.

**3.4 SAR Measurement Procedure**

According to the SAR test standard, the recommended procedure for assessing the peak spatial-average SAR value consists of the following steps:

- (a) Power reference measurement
- (b) Area scan
- (c) Zoom scan
- (d) Power drift measurement

The SAR measurement procedures for each of test conditions are as follows:

- (a) Make EUT to transmit maximum output power
- (b) Measure conducted output power through RF cable
- (c) Place the EUT in the specific position of phantom
- (d) Perform SAR testing steps on the DASY system
- (e) Record the SAR value

**3.4.1 Area & Zoom Scan Procedure**

First Area Scan is used to locate the approximate location(s) of the local peak SAR value(s). The measurement grid within an Area Scan is defined by the grid extent, grid step size and grid offset. Next, in order to determine the EM field distribution in a three-dimensional spatial extension, Zoom Scan is required. The Zoom Scan is performed around the highest E-field value to determine the averaged SAR-distribution over 10 g. According to KDB 865664D01, the resolution for Area and Zoom scan is specified in the table below.

Items	<= 2 GHz	2-3 GHz	3-4 GHz	4-5 GHz	5-6 GHz
Area Scan ( $\Delta x, \Delta y$ )	<= 15 mm	<= 12 mm	<= 12 mm	<= 10 mm	<= 10 mm
Zoom Scan ( $\Delta x, \Delta y$ )	<= 8 mm	<= 5 mm	<= 5 mm	<= 4 mm	<= 4 mm
Zoom Scan ( $\Delta z$ )	<= 5 mm	<= 5 mm	<= 4 mm	<= 3 mm	<= 2 mm
Zoom Scan Volume	>= 30 mm	>= 30 mm	>= 28 mm	>= 25 mm	>= 22 mm

**Note:**

When zoom scan is required and report SAR is <=1.4 W/kg, the zoom scan resolution of  $\Delta x / \Delta y$  (2-3GHz: <= 8 mm, 3-4GHz: <= 7 mm, 4-6GHz: <= 5 mm) may be applied.

**3.4.2 Volume Scan Procedure**

The volume scan is used for assess overlapping SAR distributions for antennas transmitting in different frequency bands. It is equivalent to an oversized zoom scan used in standalone measurements. The measurement volume will be used to enclose all the simultaneous transmitting antennas. For antennas transmitting simultaneously in different frequency bands, the volume scan is measured separately in each frequency band. In order to sum correctly to compute the 1g aggregate SAR, the EUT remain in the same test position for all measurements and all volume scan use the same spatial resolution and grid spacing. When all volume scan were completed, the software, SEMCAD postprocessor can combine and subsequently superpose these measurement data to calculating the multiband SAR.

### 3.4.3 Power Drift Monitoring

All SAR testing is under the EUT install full charged battery and transmit maximum output power. In DASY measurement software, the power reference measurement and power drift measurement procedures are used for monitoring the power drift of EUT during SAR test. Both these procedures measure the field at a specified reference position before and after the SAR testing. The software will calculate the field difference in dB. If the power drift more than 5%, the SAR will be retested.

### 3.4.4 Spatial Peak SAR Evaluation

The procedure for spatial peak SAR evaluation has been implemented according to the test standard. It can be conducted for 1g and 10g, as well as for user-specific masses. The DASY software includes all numerical procedures necessary to evaluate the spatial peak SAR value.

The base for the evaluation is a "cube" measurement. The measured volume must include the 1g and 10g cubes with the highest averaged SAR values. For that purpose, the center of the measured volume is aligned to the interpolated peak SAR value of a previously performed area scan.

The entire evaluation of the spatial peak values is performed within the post-processing engine (SEMCAD). The system always gives the maximum values for the 1g and 10g cubes. The algorithm to find the cube with highest averaged SAR is divided into the following stages:

- (a) Extraction of the measured data (grid and values) from the Zoom Scan
- (b) Calculation of the SAR value at every measurement point based on all stored data (A/D values and measurement parameters)
- (c) Generation of a high-resolution mesh within the measured volume
- (d) Interpolation of all measured values from the measurement grid to the high-resolution grid
- (e) Extrapolation of the entire 3-D field distribution to the phantom surface over the distance from sensor to surface
- (f) Calculation of the averaged SAR within masses of 1g and 10g

### 3.4.5 SAR Averaged Methods

In DASY, the interpolation and extrapolation are both based on the modified Quadratic Shepard's method. The interpolation scheme combines a least-square fitted function method and a weighted average method which are the two basic types of computational interpolation and approximation.

Extrapolation routines are used to obtain SAR values between the lowest measurement points and the inner phantom surface. The extrapolation distance is determined by the surface detection distance and the probe sensor offset. The uncertainty increases with the extrapolation distance. To keep the uncertainty within 1% for the 1 g and 10 g cubes, the extrapolation distance should not be larger than 5 mm.



## 4. SAR Measurement Evaluation

### 4.1 EUT Configuration and Setting

#### <Considerations Related to Proximity Sensor>

The device supports WWAN, WLAN, and Bluetooth capabilities. It is designed with a proximity sensor which can trigger/not trigger power reduction for GSM, WCDMA and LTE on Rear Face and Bottom Side, and WLAN on Front Face, Rear Face and Bottom Side of EUT for SAR compliance. Others RF capability (Bluetooth) have no power reduction. The power levels for all wireless technologies and the power reduction please refer to section 4.6 of this report.

#### Proximity Sensor Triggering Distances (KDB 616217 D04 §6.2)

The proximity sensor triggering distance was determined per KDB 616217 for rear face and applicable edge. Summary for power verification per distance was tabulated in the below table.

Output Power Verification in dBm for EUT Front Face											
Distance (mm)	15	16	17	18	19	20	21	22	23	24	25
WLAN 2.4G	14.6	14.8	14.9	14.6	14.8	15.0	19.5	19.0	19.4	19.0	19.2
WLAN 5.2G	12.0	12.3	12.5	12.2	12.1	12.2	17.2	17.0	17.2	17.2	17.0
WLAN 5.3G	12.5	12.2	12.2	12.2	12.2	12.3	17.0	17.4	17.5	17.3	17.3
WLAN 5.6G	12.3	12.3	12.1	12.5	12.3	12.5	18.5	18.1	18.2	18.1	18.0
WLAN 5.8G	12.2	12.2	12.2	12.0	12.5	12.3	17.3	17.1	17.0	17.4	17.3

Output Power Verification in dBm for EUT Rear Face											
Distance (mm)	19	20	21	22	23	24	25	26	27	28	29
WCDMA II	20.0	20.0	19.7	19.7	19.8	19.9	22.7	22.5	22.5	22.6	22.5
WCDMA IV	19.7	19.6	20.0	19.5	19.8	19.5	21.8	22.0	22.0	21.9	21.9
LTE 2	20.5	20.2	20.6	20.4	20.5	20.7	21.8	21.8	22.0	21.9	22.0
LTE 4	20.8	20.6	20.6	20.7	20.7	20.8	21.7	21.5	22.0	22.0	21.5
LTE 7	21.0	20.9	20.9	20.9	21.0	21.0	22.4	22.0	22.1	22.0	22.1
WLAN 2.4G	14.8	14.6	14.9	14.7	14.7	14.7	19.0	19.3	19.4	19.0	19.1
WLAN 5.2G	12.3	12.1	12.4	12.0	12.0	12.4	17.2	17.4	17.0	17.1	17.3
WLAN 5.3G	12.2	12.5	12.4	12.2	12.4	12.4	17.1	17.4	17.2	17.5	17.3
WLAN 5.6G	12.5	12.1	12.2	12.5	12.2	12.2	18.0	18.2	18.3	18.1	18.3
WLAN 5.8G	12.3	12.1	12.0	12.2	12.0	12.1	17.4	17.1	17.1	17.5	17.0

Output Power Verification in dBm for EUT Bottom Edge											
Distance (mm)	26	27	28	29	30	31	32	33	34	35	36
WCDMA II	19.6	19.5	19.5	19.5	20.0	19.8	22.8	22.6	22.7	22.6	22.9
WCDMA IV	19.6	19.8	19.5	19.5	19.9	19.9	21.7	21.8	22.0	22.0	21.9
LTE 2	20.3	20.2	20.3	20.2	20.5	20.2	21.8	21.9	21.6	21.9	21.8
LTE 4	20.9	20.6	20.8	21.1	21.0	21.1	21.5	21.5	21.6	21.5	22.0
LTE 7	21.0	21.0	20.7	20.9	20.9	20.7	22.0	22.0	22.1	22.0	22.4
WLAN 2.4G	15.0	14.8	14.5	14.9	14.8	14.7	19.1	19.2	19.3	19.4	19.5
WLAN 5.2G	12.3	12.2	12.5	12.1	12.4	12.5	17.3	17.5	17.2	17.5	17.1
WLAN 5.3G	12.0	12.3	12.1	12.0	12.1	12.0	17.2	17.5	17.2	17.3	17.1
WLAN 5.6G	12.1	12.2	12.5	12.5	12.2	12.5	18.3	18.3	18.4	18.2	18.4
WLAN 5.8G	12.4	12.2	12.2	12.1	12.3	12.2	17.0	17.0	17.1	17.0	17.4

#### Proximity Sensor Coverage (KDB 616217 D04 §6.3)

Since the proximity sensor is collocated with antenna in one component, the procedure for proximity sensor coverage is not required.



**Proximity Sensor Tilt Angle Influences(KDB 616217 D04 §6.4)**

The proximity sensor tilt angle influence was determined per KDB 616217 for applicable edge. Summary for proximity sensor tilt angle influence is shown in below.

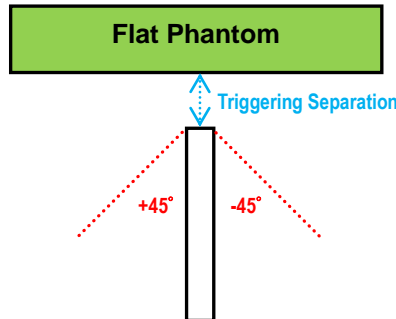

Orientation	Separation Distance (mm)	Tilt Angle										
		-45°	-40°	-30°	-20°	-10°	0°	10°	20°	30°	40°	45°
Bottom Edge	31	On	On	On	On	On	On	On	On	On	On	On

**Summary for Proximity Sensor Triggering Test**

According to the procedures noticed in KDB 616217 D04, the proximity sensor triggering distance is 24 mm for EUT Rear Face, and 31 mm for Bottom Side. The separation distance of 24 mm determined by the smallest triggering distance on Bottom Side is used to access the tilt angle influence and the sensor does not release during ±45 degree. Therefore, the smallest separation distance for tilt angle influence is 31 mm for the Bottom Side. The conservation triggering distances based on the separation distance for the sensor trigger / not triggered as EUT with power reduction at 0 mm.

The power reduction is depends on the proximity sensor input. For a steady SAR test, the power reduction was enabled or disabled manually by engineering software during SAR testing.

### <Connections between EUT and System Simulator>

For WWAN SAR testing, the EUT was linked and controlled by base station emulator. Communication between the EUT and the emulator was established by air link. The distance between the EUT and the communicating antenna of the emulator is larger than 50 cm and the output power radiated from the emulator antenna is at least 30 dB smaller than the output power of EUT. The EUT was set from the emulator to radiate maximum output power during SAR testing.

### <Considerations Related to GSM / GPRS / EDGE for Setup and Testing>

The maximum multi-slot capability supported by this device is as below.

1. This EUT is class B device
2. This EUT supports GPRS multi-slot class 12 (max. uplink: 4, max. downlink: 4, total timeslots: 5)
3. This EUT supports EDGE multi-slot class 12 (max. uplink: 4, max. downlink: 4, total timeslots: 5)

For GSM850 frequency band, the power control level is set to 5 for GSM mode and GPRS (GMSK: CS1), and set to 8 for EDGE (GMSK: MCS1, 8PSK: MCS9). For GSM1900 frequency band, the power control level is set to 0 for GSM mode and GPRS (GMSK: CS1), and set to 2 for EDGE (GMSK: MCS1, 8PSK: MCS9).

SAR test reduction for GPRS and EDGE modes is determined by the source-based time-averaged output power specified for production units, including tune-up tolerance. The data mode with highest specified time-averaged output power should be tested for SAR compliance in the applicable exposure conditions. For modes with the same specified maximum output power and tolerance, the higher number time-slot configuration should be tested.

### <Considerations Related to WCDMA for Setup and Testing>

#### WCDMA Handsets Head SAR

SAR for next to the ear head exposure is measured using a 12.2 kbps RMC with TPC bits configured to all "1's". The 3G SAR test reduction procedure is applied to AMR configurations with 12.2 kbps RMC as the primary mode.

#### WCDMA Handsets Body-worn SAR

SAR for body-worn configurations is measured using a 12.2 kbps RMC with TPC bits configured to all "1's". The 3G SAR test reduction procedure is applied to other spreading codes and multiple DPDCH<sub>n</sub> configurations supported by the handset with 12.2 kbps RMC as the primary mode.

#### Handsets with Release 5 HSDPA

The 3G SAR test reduction procedure is applied to HSDPA body-worn configurations with 12.2 kbps RMC as the primary mode. Otherwise, SAR is measured for HSDPA using the HSDPA body SAR procedures in the "Release 5 HSDPA Data Devices", for the highest reported SAR body-worn exposure configuration in 12.2 kbps RMC. Handsets with both HSDPA and HSUPA are tested according to Release 6 HSPA test procedures.

#### Handsets with Release 6 HSUPA

The 3G SAR test reduction procedure is applied to HSPA (HSUPA/HSDPA with RMC) body-worn configurations with 12.2 kbps RMC as the primary mode. Otherwise, SAR is measured for HSPA using the HSPA body SAR procedures in the "Release 6 HSPA Data Devices", for the highest reported body-worn exposure SAR configuration in 12.2 kbps RMC. When VOIP is applicable for next to the ear head exposure in HSPA, the 3G SAR test reduction procedure is applied to HSPA with 12.2 kbps RMC as the primary mode; otherwise, the same HSPA configuration used for body-worn measurements is tested for next to the ear head exposure.

#### Release 5 HSDPA Data Devices

The 3G SAR test reduction procedure is applied to body SAR with 12.2 kbps RMC as the primary mode. Otherwise, body SAR for HSDPA is measured using an FRC with H-Set 1 in Sub-test 1 and a 12.2 kbps RMC configured in Test Loop Mode 1, for the highest reported SAR configuration in 12.2 kbps RMC without HSDPA. HSDPA is configured according to the applicable UE category of a test device. The number of HS-DSCH/HS-PDSCHs, HARQ processes, minimum inter-TTI interval, transport block sizes and RV coding sequence are defined by the H-set. To maintain a consistent test configuration and stable transmission conditions, QPSK is used in the H-set for SAR testing. HS-DPCCH should be configured with a CQI feedback cycle of 4 ms and a CQI repetition factor of 2 to maintain a constant rate of active CQI slots. DPCCH and DPDCH gain factors ( $\beta_c$ ,  $\beta_d$ ), and HS-DPCCH power offset parameters ( $\Delta_{ACK}$ ,  $\Delta_{NACK}$ ,  $\Delta_{CQI}$ ) are set according to values indicated in below. The CQI value is determined by the UE category, transport block size, number of HS-PDSCHs and modulation used in the H-set.

# FCC SAR Test Report

Sub-test	$\beta_c$	$\beta_d$	$\beta_d$ (SF)	$\beta_c/\beta_d$	$\beta_{HS}^{(1)(2)}$	CM <sup>(3)</sup> (dB)	MPR <sup>(3)</sup> (dB)
1	2/15	15/15	64	2/15	4/15	0.0	0.0
2	12/15 <sup>(4)</sup>	15/15 <sup>(4)</sup>	64	12/15 <sup>(4)</sup>	24/15	1.0	0.0
3	15/15	8/15	64	15/8	30/15	1.5	0.5
4	15/15	4/15	64	15/4	30/15	1.5	0.5

Note 1:  $\Delta_{ACK}$ ,  $\Delta_{NACK}$  and  $\Delta_{CQI} = 30/15$  with  $\beta_{HS} = 30/15 * \beta_c$ .

Note 2: For the HS-DPCCH power mask requirement test in clause 5.2C, 5.7A, and the Error Vector Magnitude (EVM) with HS-DPCCH test in clause 5.13.1A, and HSDPA EVM with phase discontinuity in clause 5.13.1AA,  $\Delta_{ACK}$  and  $\Delta_{NACK} = 30/15$  with  $\beta_{HS} = 30/15 * \beta_c$ , and  $\Delta_{CQI} = 24/15$  with  $\beta_{HS} = 24/15 * \beta_c$ .

Note 3: CM = 1 for  $\beta_c/\beta_d = 12/15, \beta_{HS}/\beta_c = 24/15$ . For all other combinations of DPDCH, DPCCH and HS-DPCCH the MPR is based on the relative CM difference. This is applicable for only UEs that support HSDPA in release 6 and later releases.

Note 4: For subtest 2 the  $\beta_c/\beta_d$  ratio of 12/15 for the TFC during the measurement period (TF1, TF0) is achieved by setting the signalled gain factors for the reference TFC (TF1, TF1) to  $\beta_c = 11/15$  and  $\beta_d = 15/15$ .

## Release 6 HSPA Data Devices

The 3G SAR test reduction procedure is applied to body SAR with 12.2 kbps RMC as the primary mode. Otherwise, body SAR for HSPA is measured with E-DCH Sub-test 5, using H-Set 1 and QPSK for FRC and a 12.2 kbps RMC configured in Test Loop Mode 1 and power control algorithm 2, according to the highest reported body SAR configuration in 12.2 kbps RMC without HSPA. When VOIP applies to head exposure, the 3G SAR test reduction procedure is applied with 12.2 kbps RMC as the primary mode. Otherwise, the same HSPA configuration used for body SAR measurements are applied to head exposure testing. Due to inner loop power control requirements in HSPA, a communication test set is required for output power and SAR tests. The 12.2 kbps RMC, FRC H-set 1 and E-DCH configurations for HSPA are configured according to the  $\beta$  values indicated in below.

Sub-test	$\beta_c$	$\beta_d$	$\beta_d$ (SF)	$\beta_c/\beta_d$	$\beta_{HS}^{(1)}$	$\beta_{ec}$	$\beta_{ed}^{(4)(5)}$	$\beta_{ed}$ (SF)	$\beta_{ed}$ (Codes)	CM <sup>(2)</sup> (dB)	MPR <sup>(2)(6)</sup> (dB)	AG <sup>(5)</sup> Index	E-TFCI
1	11/15 <sup>(3)</sup>	15/15 <sup>(3)</sup>	64	11/15 <sup>(3)</sup>	22/15	209/225	1309/225	4	1	1.0	0.0	20	75
2	6/15	15/15	64	6/15	12/15	12/15	94/75	4	1	3.0	2.0	12	67
3	15/15	9/15	64	15/9	30/15	30/15	$\beta_{ed1}: 47/15$ $\beta_{ed2}: 47/15$	4 4	2	2.0	1.0	15	92
4	2/15	15/15	64	2/15	4/15	2/15	56/75	4	1	3.0	2.0	17	71
5	15/15	0	-	-	5/15	5/15	47/15	4	1	1.0	0.0	12	67

Note 1: For sub-test 1 to 4,  $\Delta_{ACK}$ ,  $\Delta_{NACK}$  and  $\Delta_{CQI} = 30/15$  with  $\beta_{HS} = 30/15 * \beta_c$ . For sub-test 5,  $\Delta_{ACK}$ ,  $\Delta_{NACK}$  and  $\Delta_{CQI} = 5/15$  with  $\beta_{HS} = 5/15 * \beta_c$ .

Note 2: CM = 1 for  $\beta_c/\beta_d = 12/15, \beta_{HS}/\beta_c = 24/15$ . For all other combinations of DPDCH, DPCCH, HS-DPCCH, E-DPCCH and E-DPCCH the MPR is based on the relative CM difference.

Note 3: For subtest 1 the  $\beta_c/\beta_d$  ratio of 11/15 for the TFC during the measurement period (TF1, TF0) is achieved by setting the signalled gain factors for the reference TFC (TF1, TF1) to  $\beta_c = 10/15$  and  $\beta_d = 15/15$ .

Note 4: In case of testing by UE using E-DPDCH Physical Layer category 1, Sub-test 3 is omitted according to TS25.306 Table 5.1g.

Note 5:  $\beta_{ed}$  can not be set directly; it is set by Absolute Grant Value.

Note 6: For subtests 2, 3 and 4, UE may perform E-DPDCH power scaling at max power which could results in slightly smaller MPR values.

## DC-HSDPA SAR Guidance

The 3G SAR test reduction procedure is applied to DC-HSDPA with 12.2 kbps RMC as the primary mode. Otherwise, when SAR is required for Rel. 5 HSDPA, SAR is required for Rel. 8 DC-HSDPA. Power is measured for DC-HSDPA according to the H-Set 12, FRC configuration in Table C.8.1.12 of 3GPP TS 34.121-1 to determine SAR test reduction. A primary and a secondary serving HS-DSCH Cell are required to perform the power measurement and for the results to be acceptable.

## <Considerations Related to LTE for Setup and Testing>

This device contains LTE transmitter which follows 3GPP standards, is category 3, supports both QPSK and QAM modulations, and supported LTE band and channel bandwidth is listed in below. The output power was tested per 3GPP TS 36.521-1 maximum transmit procedures for both QPSK and QAM modulation. The results please refer to section 4.6 of this report.

EUT Supported LTE Band and Channel Bandwidth						
LTE Band	BW 1.4 MHz	BW 3 MHz	BW 5 MHz	BW 10 MHz	BW 15 MHz	BW 20 MHz
2	V	V	V	V	V	V
4	V	V	V	V	V	V
5	V	V	V	V		
7			V	V	V	V
38			V	V	V	V

The LTE maximum power reduction (MPR) in accordance with 3GPP TS 36.101 is active all times during LTE operation. The allowed MPR for the maximum output power is specified in below.

Modulation	Channel Bandwidth / RB Configurations						LTE MPR Setting (dB)
	BW 1.4 MHz	BW 3 MHz	BW 5 MHz	BW 10 MHz	BW 15 MHz	BW 20 MHz	
QPSK	> 5	> 4	> 8	> 12	> 16	> 18	1
16QAM	<= 5	<= 4	<= 8	<= 12	<= 16	<= 18	1
16QAM	> 5	> 4	> 8	> 12	> 16	> 18	2
64QAM	<= 5	<= 4	<= 8	<= 12	<= 16	<= 18	2
64QAM	> 5	> 4	> 8	> 12	> 16	> 18	3

**Note:** MPR is according to the standard and implemented in the circuit (mandatory).

In addition, the device is compliant with additional maximum power reduction (A-MPR) requirements defined in 3GPP TS 36.101 section 6.2.4 that was disabled for all FCC compliance testing.

During LTE SAR testing, the related parameters of operating band, channel bandwidth, uplink channel number, modulation type, and RB was set in base station simulator. When the EUT has registered and communicated to base station simulator, the simulator set to make EUT transmitting the maximum radiated power.

# FCC SAR Test Report

## TDD-LTE Setup Configurations

According to KDB 941225 D05, SAR testing for TDD-LTE device must be tested using a fixed periodic duty factor according to the highest transmission duty factor implemented for the device and supported by the defined 3GPP TDD-LTE configurations. The TDD-LTE of this device supports frame structure type 2 defined in 3GPP TS 36.211 section 4.2, and the frame structure configuration can be referred to below.

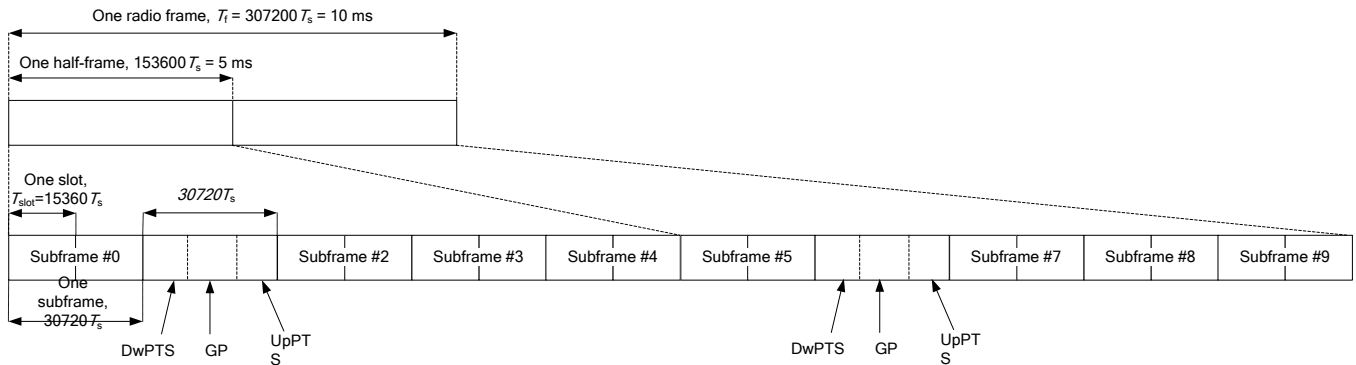

3GPP TS 36.211 Figure 4.2-1: Frame Structure Type 2

Special Subframe Configuration	Normal Cyclic Prefix in Downlink			Extended Cyclic Prefix in Downlink		
	DwPTS	UpPTS		DwPTS	UpPTS	
		Normal Cyclic Prefix in Uplink	Extended Cyclic Prefix in Uplink		Normal Cyclic Prefix in Uplink	Extended Cyclic Prefix in Uplink
0	$6592 \cdot T_s$	$2192 \cdot T_s$	$2560 \cdot T_s$	$7680 \cdot T_s$	$2192 \cdot T_s$	$2560 \cdot T_s$
1	$19760 \cdot T_s$			$20480 \cdot T_s$		
2	$21952 \cdot T_s$			$23040 \cdot T_s$		
3	$24144 \cdot T_s$			$25600 \cdot T_s$		
4	$26336 \cdot T_s$			$7680 \cdot T_s$		
5	$6592 \cdot T_s$	$4384 \cdot T_s$	$5120 \cdot T_s$	$20480 \cdot T_s$	$4384 \cdot T_s$	$5120 \cdot T_s$
6	$19760 \cdot T_s$			$23040 \cdot T_s$		
7	$21952 \cdot T_s$			$12800 \cdot T_s$		
8	$24144 \cdot T_s$			-		
9	$13168 \cdot T_s$	-	-	-	-	-

3GPP TS 36.211 Table 4.2-1: Configuration of Special Subframe

Uplink-Downlink Configuration	Downlink-to-Uplink Switch-Point Periodicity	Subframe Number										
		0	1	2	3	4	5	6	7	8	9	
0	5 ms	D	S	U	U	U	D	S	U	U	U	
1	5 ms	D	S	U	U	D	D	S	U	U	D	
2	5 ms	D	S	U	D	D	D	S	U	D	D	
3	10 ms	D	S	U	U	U	D	D	D	D	D	
4	10 ms	D	S	U	U	D	D	D	D	D	D	
5	10 ms	D	S	U	D	D	D	D	D	D	D	
6	5 ms	D	S	U	U	U	D	S	U	U	D	

3GPP TS 36.211 Table 4.2-2: Uplink-Downlink Configurations

# FCC SAR Test Report

The variety of different TD-LTE uplink-downlink configurations allows a network operator to allocate the network's capacity between uplink and downlink traffic to meet the needs of the network. The uplink duty cycle of these seven configurations can readily be computed and shown in below.

UL-DL Configuration	0	1	2	3	4	5	6
Highest Duty-Cycle	63.33%	43.33%	23.33%	31.67%	21.67%	11.67%	53.33%

Considering the highest transmission duty cycle, TDD-LTE was tested using Uplink-Downlink Configuration 0 with 6 uplink subframe and 2 special subframe. The special subframe was set to special subframe configuration 7 using extended cyclic prefix uplink. Therefore, SAR testing for TDD-LTE was performed at the maximum output power with highest transmission duty cycle of 63.33%.

## LTE Downlink Carrier Aggregation(CA)Setup Configurations

LTE Carrier Aggregation (CA) was defined in 3GPP release 10 and higher. The LTE device in CA mode has one Primary Component Carrier (PCC) and one or more Secondary Component Carriers (SCC). PCC acts as the anchor carrier and can optionally cross-schedule data transmission on SCC. The RRC connection is only handled by one cell, the PCC for downlink and uplink communications. After making a data connection to the PCC, the LTE device adds the SCC on the downlink only. All uplink communications and acknowledgements remain identical to release 8 specifications on the PCC. The combinations of downlink carrier aggregation supported by this device are listed in below.

### LTE CA Configurations and Bandwidth Combination Sets defined for Intra-Band Contiguous CA

Downlink CA Configuration	Component carriers in order of increasing carrier frequency			Maximum Aggregated Bandwidth (MHz)	Bandwidth Combination Set
	Channel bandwidths for carrier-1 (MHz)	Channel bandwidths for carrier-2 (MHz)	Channel bandwidths for carrier-3 (MHz)		
CA_7C	15	15		40	0
	20	20			
	10	20			
	15	15, 20		40	1
	20	10, 15, 20			
	15	10, 15			
CA_38C	20	15, 20		40	2
	15	15			
	20	20			

### LTE CA Configurations and Bandwidth Combination Sets defined for Intra-Band Non-Contiguous CA

Downlink CA Configuration	Component Carriers in order of Increasing Carrier Frequency			Maximum Aggregated Bandwidth (MHz)	Bandwidth Combination Set
	Channel Bandwidths for Carrier-1 (MHz)	Channel Bandwidths for Carrier-2 (MHz)	Channel Bandwidths for Carrier-3 (MHz)		
CA_7A-7A	5	15		40	0
	10	10, 15			
	15	15, 20			
	20	20			
	5, 10, 15, 20	5, 10, 15, 20		40	1
	5, 10, 15, 20	5, 10		30	2
	10, 15, 20	10, 15, 20		40	3

**<SAR Test Exclusion Evaluations for LTE Downlink CA>**

According to Nov 2017 TCB Workshop, SAR test exclusion for LTE downlink Carrier Aggregation is determined by power measurements according to the number of component carriers (CCs) supported by the product implementation. The downlink Carrier Aggregation configurations are tabulated in separate columns. DL CA would be listed in the columns corresponding to Intra Band contiguous, Intra Band Non-contiguous. The CA/CC combinations in each columns are sorted so that frequency bands listed in subsequent columns on each row are ascending subsets, as following LTE Downlink CA table and LTE Downlink CA table ; i.e., columns to the right correspond to increasing number of frequency bands and CCs.

LTE Downlink CA-Configure	Intra Band	
	2CC Non-Contiguous	
	CA_7C	CA_7A-7A
CA_38C		

- Only yellow highlighted cells need power measurement.

**LTE Uplink Carrier Aggregation (CA) Setup Configurations**

This device supports LTE uplink CA for band 41 only with a maximum of two 20 MHz carrier components in the uplink. The maximum output power for uplink intra-band contiguous CA specified in Table 6.2.2A-1 of 3GPP TS 36.101 is the same as single carrier specified in Table 6.2.2-1 of 3GPP TS 36.101. In Table 6.2.3A-1 of 3GPP TS 36.101, the MPR (maximum power reduction) for several dB is allowed due to modulation and contiguously aggregated transmit bandwidth configuration. All the RF parameters in this device have followed above 3GPP criteria.

**LTE CA Configurations and Bandwidth Combination Sets defined for Intra-Band Contiguous CA**

Uplink CA Configuration	Component carriers in order of increasing carrier frequency			Maximum Aggregated Bandwidth (MHz)	Bandwidth Combination Set
	Channel bandwidths for carrier-1 (MHz)	Channel bandwidths for carrier-2 (MHz)	Channel bandwidths for carrier-3 (MHz)		
CA_7C	15	15		40	0
	20	20			
	10	20		40	1
	15	15, 20			
	20	10, 15, 20			
	15	10, 15			
CA_38C	20	15, 20		40	2
	15	15			
	20	20		40	0



### <Considerations Related to WLAN for Setup and Testing>

In general, various vendor specific external test software and chipset based internal test modes are typically used for SAR measurement. These chipset based test mode utilities are generally hardware and manufacturer dependent, and often include substantial flexibility to reconfigure or reprogram a device. A Wi-Fi device must be configured to transmit continuously at the required data rate, channel bandwidth and signal modulation, using the highest transmission duty factor supported by the test mode tools for SAR measurement. The test frequencies established using test mode must correspond to the actual channel frequencies. When 802.11 frame gaps are accounted for in the transmission, a maximum transmission duty factor of 92 - 96% is typically achievable in most test mode configurations. A minimum transmission duty factor of 85% is required to avoid certain hardware and device implementation issues related to wide range SAR scaling. In addition, a periodic transmission duty factor is required for current generation SAR systems to measure SAR correctly. The reported SAR must be scaled to 100% transmission duty factor to determine compliance at the maximum tune-up tolerance limit.

According to KDB 248227 D01, this device has installed WLAN engineering testing software which can provide continuous transmitting RF signal. During WLAN SAR testing, this device was operated to transmit continuously at the maximum transmission duty with specified transmission mode, operating frequency, lowest data rate, and maximum output power.

### Initial Test Configuration

An initial test configuration is determined for OFDM transmission modes in 2.4 GHz and 5 GHz bands according to the channel bandwidth, modulation and data rate combination(s) with the highest maximum output power specified for production units in each standalone and aggregated frequency band. When the same maximum power is specified for multiple transmission modes in a frequency band, the largest channel bandwidth, lowest order modulation, lowest data rate and lowest order 802.11a/g/n/ac mode is used for SAR measurement, on the highest measured output power channel in the initial test configuration, for each frequency band.

### Subsequent Test Configuration

SAR measurement requirements for the remaining 802.11 transmission mode configurations that have not been tested in the initial test configuration are determined separately for each standalone and aggregated frequency band, in each exposure condition, according to the maximum output power specified for production units. Additional power measurements may be required to determine if SAR measurements are required for subsequent highest output power channels in a subsequent test configuration. When the highest reported SAR for the initial test configuration according to the initial test position or fixed exposure position requirements, is adjusted by the ratio of the subsequent test configuration to initial test configuration specified maximum output power and the adjusted SAR is  $\leq 1.2$  W/kg, SAR is not required for that subsequent test configuration.

### **SAR Test Configuration and Channel Selection**

When multiple channel bandwidth configurations in a frequency band have the same specified maximum output power, the initial test configuration is using largest channel bandwidth, lowest order modulation, lowest data rate, and lowest order 802.11 mode (i.e., 802.11a is chosen over 802.11n then 802.11ac or 802.11g is chosen over 802.11n). After an initial test configuration is determined, if multiple test channels have the same measured maximum output power, the channel chosen for SAR measurement is determined according to the following.

- 1) The channel closest to mid-band frequency is selected for SAR measurement.
- 2) For channels with equal separation from mid-band frequency; for example, high and low channels or two mid-band channels, the higher frequency (number) channel is selected for SAR measurement.

### **Test Reduction for U-NII-1 (5.2 GHz) and U-NII-2A (5.3 GHz) Bands**

For devices that operate in both U-NII bands using the same transmitter and antenna(s), SAR test reduction is determined according to the following.

- 1) When the same maximum output power is specified for both bands, begin SAR measurement in U-NII-2A band by applying the OFDM SAR requirements. If the highest reported SAR for a test configuration is  $\leq 1.2$  W/kg, SAR is not required for U-NII-1 band for that configuration (802.11 mode and exposure condition).
- 2) When different maximum output power is specified for the bands, begin SAR measurement in the band with higher specified maximum output power. The highest reported SAR for the tested configuration is adjusted by the ratio of lower to higher specified maximum output power for the two bands. When the adjusted SAR is  $\leq 1.2$  W/kg, SAR is not required for the band with lower maximum output power in that test configuration.

### **<Considerations Related to Bluetooth for Setup and Testing>**

This device has installed Bluetooth engineering testing software which can provide continuous transmitting RF signal. During Bluetooth SAR testing, this device was operated to transmit continuously at the maximum transmission duty with specified transmission mode, operating frequency, lowest data rate, and maximum output power.

The Bluetooth call box has been used during SAR measurement and the EUT was set to DH5 mode at the maximum output power. Its duty factor was calculated as below and the measured SAR for Bluetooth would be scaled to the 100% transmission duty factor to determine compliance.

## FCC SAR Test Report



**Time-domain plot for Bluetooth transmission signal**

The duty factor of Bluetooth signal has been calculated as following.

Duty Factor = 100 %

## 4.2 EUT Testing Position

### 4.2.1 Head Exposure Conditions

Head exposure is limited to next to the ear voice mode operations. Head SAR compliance is tested according to the test positions defined in IEEE Std 1528-2003 using the SAM phantom illustrated as below.

1. Define two imaginary lines on the handset
  - (a) The vertical centerline passes through two points on the front side of the handset - the midpoint of the width  $w_t$  of the handset at the level of the acoustic output, and the midpoint of the width  $w_b$  of the bottom of the handset.
  - (b) The horizontal line is perpendicular to the vertical centerline and passes through the center of the acoustic output. The horizontal line is also tangential to the face of the handset at point A.
  - (c) The two lines intersect at point A. Note that for many handsets, point A coincides with the center of the acoustic output; however, the acoustic output may be located elsewhere on the horizontal line. Also note that the vertical centerline is not necessarily parallel to the front face of the handset, especially for clamshell handsets, handsets with flip covers, and other irregularly shaped handsets.

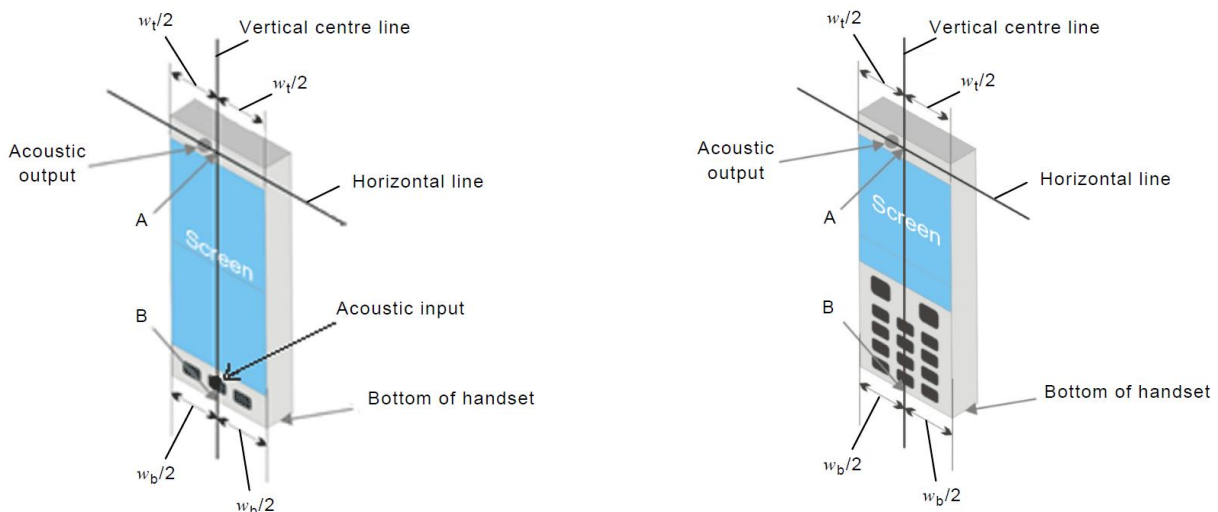

**Fig-4.1 Illustration for Handset Vertical and Horizontal Reference Lines**

**2. Cheek Position**

- (a) To position the device with the vertical center line of the body of the device and the horizontal line crossing the center piece in a plane parallel to the sagittal plane of the phantom. While maintaining the device in this plane, align the vertical center line with the reference plane containing the three ear and mouth reference point (M: Mouth, RE: Right Ear, and LE: Left Ear) and align the center of the ear piece with the line RE-LE.
- (b) To move the device towards the phantom with the ear piece aligned with the line LE-RE until the phone touched the ear. While maintaining the device in the reference plane and maintaining the phone contact with the ear, move the bottom of the phone until any point on the front side is in contact with the cheek of the phantom or until contact with the ear is lost (see Fig-4.2).

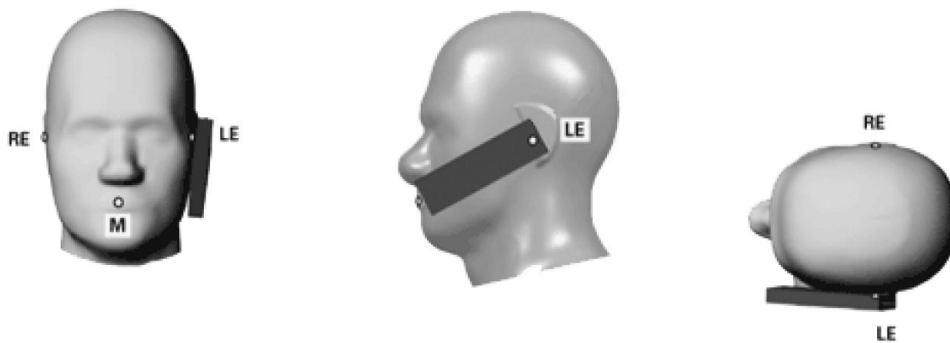

**Fig-4.2 Illustration for Cheek Position**

**3. Tilted Position**

- (a) To position the device in the “cheek” position described above.
- (b) While maintaining the device the reference plane described above and pivoting against the ear, moves it outward away from the mouth by an angle of 15 degrees or until contact with the ear is lost (see Fig-4.3).

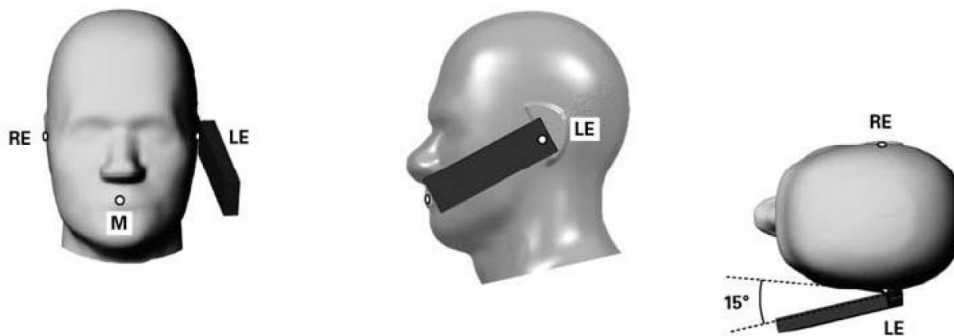

**Fig-4.3 Illustration for Tilted Position**

**4.2.2 Body-worn Accessory Exposure Conditions**

Body-worn accessory exposure is typically related to voice mode operations when handsets are carried in body-worn accessories. The body-worn accessory procedures in KDB 447498 D01 are used to test for body-worn accessory SAR compliance, without a headset connected to it. This enables the test results for such configuration to be compatible with that required for hotspot mode when the body-worn accessory test separation distance is greater than or equal to that required for hotspot mode. When the reported SAR for a body-worn accessory, measured without a headset connected to the handset, is  $> 1.2 \text{ W/kg}$ , the highest reported SAR configuration for that wireless mode and frequency band should be repeated for that body-worn accessory with a headset attached to the handset.

Body-worn accessories that do not contain metallic or conductive components may be tested according to worst-case exposure configurations, typically according to the smallest test separation distance required for the group of body-worn accessories with similar operating and exposure characteristics. All body-worn accessories containing metallic components are tested in conjunction with the host device.

Body-worn accessory SAR compliance is based on a single minimum test separation distance for all wireless and operating modes applicable to each body-worn accessory used by the host, and according to the relevant voice and/or data mode transmissions and operations. If a body-worn accessory supports voice only operations in its normal and expected use conditions, testing of data mode for body-worn compliance is not required.

A conservative minimum test separation distance for supporting off-the-shelf body-worn accessories that may be acquired by users of consumer handsets is used to test for body-worn accessory SAR compliance. This distance is determined by the handset manufacturer, according to the requirements of Supplement C 01-01. Devices that are designed to operate on the body of users using lanyards and straps, or without requiring additional body-worn accessories, will be tested using a conservative minimum test separation distance  $\leq 5 \text{ mm}$  to support compliance.

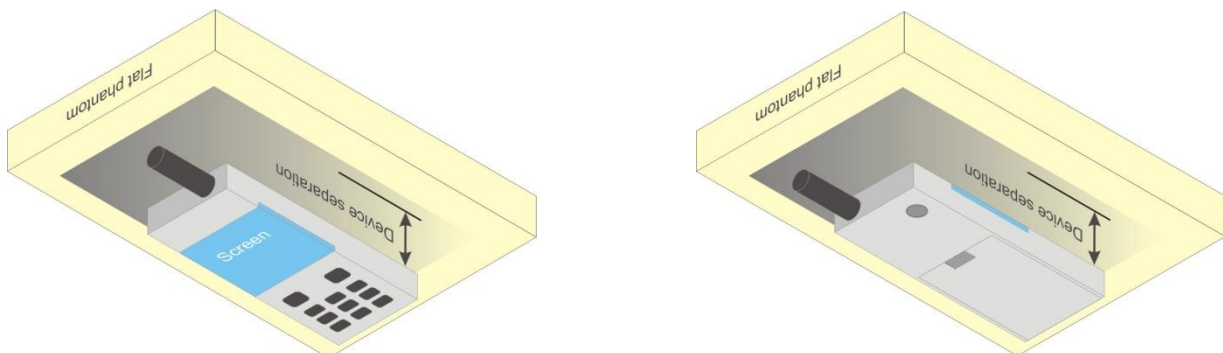

**Fig-4.4 Illustration for Body Worn Position**

**4.2.3 Hotspot Mode Exposure Conditions**

For handsets that support hotspot mode operations, with wireless router capabilities and various web browsing functions, the relevant hand and body exposure conditions are tested according to the hotspot SAR procedures in KDB 941225 D06. A test separation distance of 10 mm is required between the phantom and all surfaces and edges with a transmitting antenna located within 25 mm from that surface or edge. When the form factor of a handset is smaller than 9 cm x 5 cm, a test separation distance of 5 mm (instead of 10 mm) is required for testing hotspot mode. When the separation distance required for body-worn accessory testing is larger than or equal to that tested for hotspot mode, in the same wireless mode and for the same surface of the phone, the hotspot mode SAR data may be used to support body-worn accessory SAR compliance for that particular configuration (surface).

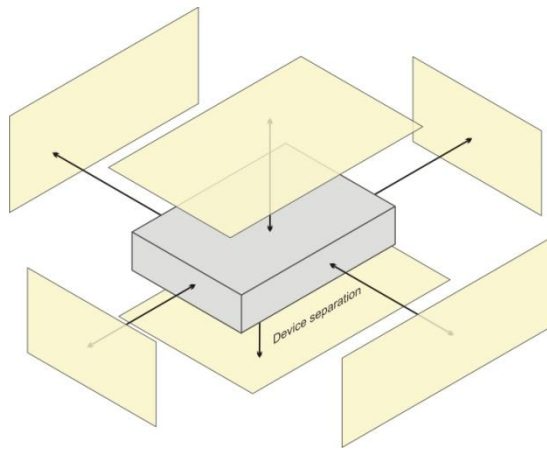

Based on the antenna location shown on appendix D of this report, the SAR testing required for hotspot mode is listed as below.

Antenna	Front Face	Rear Face	Left Side	Right Side	Top Side	Bottom Side
WWAN (Main) Ant-0	V	V	V	V		V
WWAN (DIV) Ant-1	V	V	V		V	
WLAN / BT	V	V		V	V	



### 4.2.4 Product Specific (Phablet) Exposure Conditions

For smart phones with a display diagonal dimension  $> 15$  cm or an overall diagonal dimension  $> 16$  cm that provide similar mobile web access and multimedia support found in mini-tablets or UMPC mini-tablets that support voice calls next to the ear, the following Phablet procedures should be applied to evaluate SAR compliance for each applicable wireless mode and frequency band. Devices marketed as Phablets, regardless of form factors and operating characteristics must be tested as a Phablet to determine SAR compliance.

1. The normally required head and body-worn accessory SAR test procedures for handsets, including hotspot mode, must be applied.
2. The UMPC mini-tablet procedures must also be applied to test the SAR of all surfaces and edges with an antenna located at  $\leq 25$  mm from that surface or edge, in direct contact with a flat phantom, for 10-g extremity SAR according to the body-equivalent tissue dielectric parameters in KDB 865664 to address interactive hand use exposure conditions. The UMPC mini-tablet 1-g SAR at 5 mm is not required. When hotspot mode applies, 10-g extremity SAR is required only for the surfaces and edges with hotspot mode 1-g SAR  $> 1.2$  W/kg. The normal tablet procedures in KDB 616217 are required when the over diagonal dimension of the device is  $> 20$  cm. Hotspot mode SAR is not required when normal tablet procedures are applied. Extremity 10-g SAR is also not required for the front (top) surface of large form factor full size tablets. The more conservative tablet SAR results can be used to support the 10-g extremity SAR for Phablet mode.
3. The simultaneous transmission operating configurations applicable to voice and data transmissions for both phone and mini-tablet modes must be taken into consideration separately for 1-g and 10-g SAR to determine the simultaneous transmission SAR test exclusion and measurement requirements for the relevant wireless mode and exposure conditions.



**4.3 Tissue Verification**

The measuring results for tissue simulating liquid are shown as below.

<Head / Body>

Test Date	Frequency (MHz)	Liquid Temp. (°C)	Measured Conductivity ( $\sigma$ )	Measured Permittivity ( $\epsilon_r$ )	Target Conductivity ( $\sigma$ )	Target Permittivity ( $\epsilon_r$ )	Conductivity Deviation (%)	Permittivity Deviation (%)
Jul. 24, 2019	835	23.3	0.928	41.992	0.9	41.5	3.11	1.19
Jul. 25, 2019	835	23.2	0.921	42.338	0.9	41.5	2.33	2.02
Jul. 25, 2019	835	23.3	0.916	40.658	0.9	41.5	1.78	-2.03
Aug. 03, 2019	835	23.3	0.919	41.728	0.9	41.5	2.11	0.55
Jul. 30, 2019	1750	23.3	1.321	40.14	1.37	40.1	-3.58	0.10
Aug. 02, 2019	1750	23.2	1.333	39.645	1.37	40.1	-2.70	-1.13
Aug. 05, 2019	1750	23.1	1.32	39.741	1.37	40.1	-3.65	-0.90
Jul. 24, 2019	1900	23.1	1.456	39.753	1.4	40	4.00	-0.62
Jul. 25, 2019	1900	23.3	1.46	38.759	1.4	40	4.29	-3.10
Jul. 30, 2019	1900	23.3	1.451	39.609	1.4	40	3.64	-0.98
Aug. 02, 2019	1900	23.2	1.461	39.136	1.4	40	4.36	-2.16
Aug. 05, 2019	1900	23.1	1.447	39.229	1.4	40	3.36	-1.93
Jul. 25, 2019	2450	23.3	1.883	38.286	1.8	39.2	4.61	-2.33
Jul. 26, 2019	2450	23.2	1.874	38.646	1.8	39.2	4.11	-1.41
Jul. 31, 2019	2450	23.1	1.885	38.34	1.8	39.2	4.72	-2.19
Aug. 06, 2019	2450	23.2	1.882	38.31	1.8	39.2	4.56	-2.27
Aug. 07, 2019	2450	23.3	1.887	38.326	1.8	39.2	4.83	-2.23
Jul. 24, 2019	2600	23.1	2.043	37.843	1.96	39	4.23	-2.97
Jul. 29, 2019	2600	23.3	2.036	37.736	1.96	39	3.88	-3.24
Jul. 31, 2019	2600	23.1	2.045	37.845	1.96	39	4.34	-2.96
Jul. 31, 2019	2600	23.3	2.026	37.53	1.96	39	3.37	-3.77
Aug. 03, 2019	2600	23.3	2.025	37.423	1.96	39	3.32	-4.04
Aug. 06, 2019	2600	23.1	2.047	38.553	1.96	39	4.44	-1.15
Jul. 27, 2019	5250	23.5	4.665	36.681	4.71	35.9	-0.96	2.18
Jul. 31, 2019	5250	23.3	4.788	35.102	4.71	35.9	1.66	-2.22
Aug. 06, 2019	5250	23.3	4.828	36.023	4.71	35.9	2.51	0.34
Aug. 07, 2019	5250	23.3	4.795	35.269	4.71	35.9	1.80	-1.76
Jul. 26, 2019	5600	23.2	5.025	34.997	5.07	35.5	-0.89	-1.42
Aug. 06, 2019	5600	23.3	5.216	35.485	5.07	35.5	2.88	-0.04
Aug. 07, 2019	5600	23.3	5.178	34.66	5.07	35.5	2.13	-2.37
Jul. 27, 2019	5750	23.5	5.084	36.412	5.22	35.4	-2.61	2.86
Aug. 06, 2019	5750	23.3	5.354	35.468	5.22	35.4	2.57	0.19
Aug. 07, 2019	5750	23.3	5.34	34.366	5.22	35.4	2.30	-2.92

# FCC SAR Test Report

## <Extremity>

Test Date	Frequency (MHz)	Liquid Temp. (°C)	Measured Conductivity ( $\sigma$ )	Measured Permittivity ( $\epsilon_r$ )	Target Conductivity ( $\sigma$ )	Target Permittivity ( $\epsilon_r$ )	Conductivity Deviation (%)	Permittivity Deviation (%)
Aug. 08, 2019	1750	23.3	1.333	39.672	1.37	40.1	-2.70	-1.07
Aug. 08, 2019	1900	23.3	1.461	39.134	1.4	40	4.36	-2.17
Aug. 08, 2019	2600	23.1	2.039	38.539	1.96	39	4.03	-1.18
Jul. 27, 2019	5250	23.5	4.665	36.681	4.71	35.9	-0.96	2.18
Aug. 07, 2019	5250	23.3	4.795	35.269	4.71	35.9	1.80	-1.76
Jul. 26, 2019	5600	23.2	5.025	34.997	5.07	35.5	-0.89	-1.42
Aug. 07, 2019	5600	23.3	5.178	34.66	5.07	35.5	2.13	-2.37

### Note:

The dielectric properties of the tissue simulating liquid must be measured within 24 hours before the SAR testing and within  $\pm 5\%$  of the target values. Liquid temperature during the SAR testing must be within  $\pm 2^\circ\text{C}$ .

## 4.4 System Validation

The SAR measurement system was validated according to procedures in KDB 865664 D01. The validation status in tabulated summary is as below.

### <Head / Body>

Test Date	Probe S/N	Calibration Point	Measured Conductivity ( $\sigma$ )	Measured Permittivity ( $\epsilon_r$ )	Validation for CW			Validation for Modulation		
					Sensitivity Range	Probe Linearity	Probe Isotropy	Modulation Type	Duty Factor	PAR
Jul. 24, 2019	7537	835	0.928	41.992	Pass	Pass	Pass	N/A	N/A	N/A
Jul. 25, 2019	7537	835	0.921	42.338	Pass	Pass	Pass	GMSK	Pass	N/A
Jul. 25, 2019	7472	835	0.916	40.658	Pass	Pass	Pass	GMSK	Pass	N/A
Aug. 03, 2019	3971	835	0.919	41.728	Pass	Pass	Pass	GMSK	Pass	N/A
Jul. 30, 2019	7472	1750	1.321	40.14	Pass	Pass	Pass	N/A	N/A	N/A
Aug. 02, 2019	3971	1750	1.333	39.645	Pass	Pass	Pass	N/A	N/A	N/A
Aug. 05, 2019	7537	1750	1.32	39.741	Pass	Pass	Pass	N/A	N/A	N/A
Jul. 24, 2019	7472	1900	1.456	39.753	Pass	Pass	Pass	N/A	N/A	N/A
Jul. 25, 2019	7472	1900	1.46	38.759	Pass	Pass	Pass	N/A	N/A	N/A
Jul. 30, 2019	7472	1900	1.451	39.609	Pass	Pass	Pass	GMSK	Pass	N/A
Aug. 02, 2019	3971	1900	1.461	39.136	Pass	Pass	Pass	N/A	N/A	N/A
Aug. 05, 2019	7537	1900	1.447	39.229	Pass	Pass	Pass	GMSK	Pass	N/A
Jul. 25, 2019	7472	2450	1.883	38.286	Pass	Pass	Pass	OFDM	N/A	Pass
Jul. 26, 2019	3650	2450	1.874	38.646	Pass	Pass	Pass	OFDM	N/A	Pass
Jul. 31, 2019	7472	2450	1.885	38.34	Pass	Pass	Pass	OFDM	N/A	Pass
Aug. 06, 2019	3971	2450	1.882	38.31	Pass	Pass	Pass	OFDM	N/A	Pass
Aug. 07, 2019	3971	2450	1.887	38.326	Pass	Pass	Pass	OFDM	N/A	Pass
Jul. 24, 2019	7472	2600	2.043	37.843	Pass	Pass	Pass	N/A	N/A	N/A
Jul. 29, 2019	7472	2600	2.036	37.736	Pass	Pass	Pass	N/A	N/A	N/A
Jul. 31, 2019	7472	2600	2.045	37.845	Pass	Pass	Pass	N/A	N/A	N/A
Jul. 31, 2019	3650	2600	2.026	37.53	Pass	Pass	Pass	N/A	N/A	N/A
Aug. 03, 2019	3971	2600	2.025	37.423	Pass	Pass	Pass	N/A	N/A	N/A
Aug. 06, 2019	7537	2600	2.047	38.553	Pass	Pass	Pass	N/A	N/A	N/A
Jul. 27, 2019	3650	5250	4.665	36.681	Pass	Pass	Pass	OFDM	N/A	Pass
Jul. 31, 2019	3650	5250	4.788	35.102	Pass	Pass	Pass	OFDM	N/A	Pass
Aug. 06, 2019	3971	5250	4.828	36.023	Pass	Pass	Pass	OFDM	N/A	Pass
Aug. 07, 2019	3971	5250	4.795	35.269	Pass	Pass	Pass	OFDM	N/A	Pass
Jul. 26, 2019	3650	5600	5.025	34.997	Pass	Pass	Pass	OFDM	N/A	Pass
Aug. 06, 2019	3971	5600	5.216	35.485	Pass	Pass	Pass	OFDM	N/A	Pass
Aug. 07, 2019	3971	5600	5.178	34.66	Pass	Pass	Pass	OFDM	N/A	Pass
Jul. 27, 2019	3650	5750	5.084	36.412	Pass	Pass	Pass	OFDM	N/A	Pass
Aug. 06, 2019	3971	5750	5.354	35.468	Pass	Pass	Pass	OFDM	N/A	Pass
Aug. 07, 2019	3971	5750	5.34	34.366	Pass	Pass	Pass	OFDM	N/A	Pass

# FCC SAR Test Report

## <Extremity>

Test Date	Probe S/N	Calibration Point	Measured Conductivity ( $\sigma$ )	Measured Permittivity ( $\epsilon_r$ )	Validation for CW			Validation for Modulation		
					Sensitivity Range	Probe Linearity	Probe Isotropy	Modulation Type	Duty Factor	PAR
Aug. 08, 2019	3971	1750	1.333	39.672	Pass	Pass	Pass	N/A	N/A	N/A
Aug. 08, 2019	3971	1900	1.461	39.134	Pass	Pass	Pass	GMSK	Pass	N/A
Aug. 08, 2019	3971	2600	2.039	38.539	Pass	Pass	Pass	N/A	N/A	N/A
Jul. 27, 2019	3650	5250	4.665	36.681	Pass	Pass	Pass	OFDM	N/A	Pass
Aug. 07, 2019	3971	5250	4.795	35.269	Pass	Pass	Pass	OFDM	N/A	Pass
Jul. 26, 2019	3650	5600	5.025	34.997	Pass	Pass	Pass	OFDM	N/A	Pass
Aug. 07, 2019	3971	5600	5.178	34.66	Pass	Pass	Pass	OFDM	N/A	Pass

## 4.5 System Verification

The measuring result for system verification is tabulated as below.

## <Head / Body>

Test Date	Frequency (MHz)	1W Target SAR-1g (W/kg)	Measured SAR-1g (W/kg)	Normalized to 1W SAR-1g (W/kg)	Deviation (%)	Dipole S/N	Probe S/N	DAE S/N
Jul. 24, 2019	835	9.44	2.27	9.08	-3.81	4d121	7537	1585
Jul. 25, 2019	835	9.44	2.41	9.64	2.12	4d121	7537	1585
Jul. 25, 2019	835	9.44	2.42	9.68	2.54	4d121	7472	579
Aug. 03, 2019	835	9.44	2.36	9.44	0.00	4d121	3971	1431
Jul. 30, 2019	1750	36.90	9.42	37.68	2.11	1055	7472	579
Aug. 02, 2019	1750	36.90	9.39	37.56	1.79	1055	3971	1431
Aug. 05, 2019	1750	36.90	8.92	35.68	-3.31	1055	7537	1585
Jul. 24, 2019	1900	40.20	9.95	39.80	-1.00	5d036	7472	579
Jul. 25, 2019	1900	40.20	10.3	41.20	2.49	5d036	7472	579
Jul. 30, 2019	1900	40.20	10.2	40.80	1.49	5d036	7472	579
Aug. 02, 2019	1900	40.20	10.1	40.40	0.50	5d036	3971	1431
Aug. 05, 2019	1900	40.20	10	40.00	-0.50	5d036	7537	1585
Jul. 25, 2019	2450	51.50	13.2	52.80	2.52	737	7472	579
Jul. 26, 2019	2450	51.50	12.8	51.20	-0.58	737	3650	861
Jul. 31, 2019	2450	51.50	13.5	54.00	4.85	737	7472	579
Aug. 06, 2019	2450	51.50	13	52.00	0.97	737	3971	1431
Aug. 07, 2019	2450	51.50	13.1	52.40	1.75	737	3971	1431
Jul. 24, 2019	2600	55.70	13.3	53.20	-4.49	1020	7472	3971
Jul. 29, 2019	2600	55.70	13.1	52.40	-5.92	1020	7472	579
Jul. 31, 2019	2600	55.70	14.9	59.60	7.00	1020	7472	579
Jul. 31, 2019	2600	55.70	13.7	54.80	-1.62	1020	3650	861
Aug. 03, 2019	2600	55.70	13.4	53.60	-3.77	1020	3971	1431
Aug. 06, 2019	2600	55.70	14.3	57.20	2.69	1020	7537	1585
Jul. 27, 2019	5250	80.70	7.59	75.90	-5.95	1019	3650	861
Jul. 31, 2019	5250	80.70	7.79	77.90	-3.47	1019	3650	861
Aug. 06, 2019	5250	80.70	8.02	80.20	-0.62	1019	3971	1431
Aug. 07, 2019	5250	80.70	7.97	79.70	-1.24	1019	3971	1431
Jul. 26, 2019	5600	85.80	8.27	82.70	-3.61	1019	3650	861
Aug. 06, 2019	5600	85.80	8.88	88.80	3.50	1019	3971	1431
Aug. 07, 2019	5600	85.80	9.1	91.00	6.06	1019	3971	1431
Jul. 27, 2019	5750	81.50	8.37	83.70	2.70	1019	3650	861
Aug. 06, 2019	5750	81.50	8.31	83.10	1.96	1019	3971	1431
Aug. 07, 2019	5750	81.50	8.12	81.20	-0.37	1019	3971	1431

## FCC SAR Test Report

### <Extremity>

Test Date	Frequency (MHz)	1W Target SAR-1g (W/kg)	Measured SAR-1g (W/kg)	Normalized to 1W SAR-1g (W/kg)	Deviation (%)	Dipole S/N	Probe S/N	DAE S/N
Aug. 08, 2019	1750	19.30	4.97	19.88	3.01	1055	3971	1431
Aug. 08, 2019	1900	20.90	5.27	21.08	0.86	5d036	3971	1431
Aug. 08, 2019	2600	25.00	6.08	24.32	-2.72	1020	3971	1431
Jul. 27, 2019	5250	23.20	2.19	21.90	-5.60	1019	3650	861
Aug. 07, 2019	5250	23.20	2.3	23.00	-0.86	1019	3971	1431
Jul. 26, 2019	5600	24.50	2.35	23.50	-4.08	1019	3650	861
Aug. 07, 2019	5600	24.50	2.6	26.00	6.12	1019	3971	1431

### Note:

Comparing to the reference SAR value provided by SPEAG, the validation data should be within its specification of 10 %. The result indicates the system check can meet the variation criterion and the plots can be referred to Appendix A of this report.

# FCC SAR Test Report

## 4.6 Maximum Output Power

### 4.6.1 Maximum Target Conducted Power

The maximum conducted average power (Unit: dBm) including tune-up tolerance is shown as below.

Mode		WWAN (Main) Ant-0															
		Full Power		Head Standalone		Head WLAN On		Body Standalone		Body WLAN On		Extremity Standalone		Extremity WLAN On		Hotspot On	
2G Band	Power Reduction Scenario	Full Power	Full Power	Power Table -1		Power Table-2		Power Table-3		Power Table-4		Power Table-5		Power Table-6		Power Table-7	
	Tune-up Limit (dBm)	Max. Tune-up Limit (dBm)															
		Burst-Averaged	Frame-Averaged	Burst-Averaged	Frame-Averaged	Burst-Averaged	Frame-Averaged	Burst-Averaged	Frame-Averaged	Burst-Averaged	Frame-Averaged	Burst-Averaged	Frame-Averaged	Burst-Averaged	Frame-Averaged	Burst-Averaged	Frame-Averaged
GSM850	GSM (GMSK, 1Tx-slot)	33.5	24.5	33.5	24.5	33.5	24.5	33.5	24.5	33.5	24.5	33.5	24.5	33.5	24.5	33.5	24.5
	GPRS (GMSK, 1Tx-slot)	33.5	24.5	33.5	24.5	33.5	24.5	33.5	24.5	33.5	24.5	33.5	24.5	33.5	24.5	33.5	24.5
	GPRS (GMSK, 2Tx-slot)	30.5	24.5	30.5	24.5	30.5	24.5	30.5	24.5	30.5	24.5	30.5	24.5	30.5	24.5	30.5	24.5
	GPRS (GMSK, 3Tx-slot)	28.7	24.44	28.7	24.44	28.7	24.44	28.7	24.44	28.7	24.44	28.7	24.44	28.7	24.44	28.7	24.44
	GPRS (GMSK, 4Tx-slot)	27.5	24.5	27.5	24.5	27.5	24.5	27.5	24.5	27.5	24.5	27.5	24.5	27.5	24.5	27.5	24.5
	EDGE (8PSK, 1Tx-slot)	27.5	18.5	27.5	18.5	27.5	18.5	27.5	18.5	27.5	18.5	27.5	18.5	27.5	18.5	27.5	18.5
	EDGE (8PSK, 2Tx-slot)	24.5	18.5	24.5	18.5	24.5	18.5	24.5	18.5	24.5	18.5	24.5	18.5	24.5	18.5	24.5	18.5
	EDGE (8PSK, 3Tx-slot)	22.7	18.44	22.7	18.44	22.7	18.44	22.7	18.44	22.7	18.44	22.7	18.44	22.7	18.44	22.7	18.44
	EDGE (8PSK, 4Tx-slot)	21.5	18.5	21.5	18.5	21.5	18.5	21.5	18.5	21.5	18.5	21.5	18.5	21.5	18.5	21.5	18.5
GSM1900	GSM (GMSK, 1Tx-slot)	30.5	21.5	30.5	21.5	30.5	21.5	30.5	21.5	30.5	21.5	30.5	21.5	30.5	21.5	28.0	19.0
	GPRS (GMSK, 1Tx-slot)	30.5	21.5	30.5	21.5	30.5	21.5	30.5	21.5	30.5	21.5	30.5	21.5	30.5	21.5	28.0	19.0
	GPRS (GMSK, 2Tx-slot)	27.5	21.5	27.5	21.5	27.5	21.5	27.5	21.5	27.5	21.5	27.5	21.5	27.5	21.5	25.0	19.0
	GPRS (GMSK, 3Tx-slot)	25.7	21.44	25.7	21.44	25.7	21.44	25.7	21.44	25.7	21.44	25.7	21.44	25.7	21.44	23.2	18.94
	GPRS (GMSK, 4Tx-slot)	24.5	21.5	24.5	21.5	24.5	21.5	24.5	21.5	24.5	21.5	24.5	21.5	24.5	21.5	22.0	19.0
	EDGE (8PSK, 1Tx-slot)	26.5	17.5	26.5	17.5	26.5	17.5	26.5	17.5	26.5	17.5	26.5	17.5	26.5	17.5	26.5	17.5
	EDGE (8PSK, 2Tx-slot)	23.5	17.5	23.5	17.5	23.5	17.5	23.5	17.5	23.5	17.5	23.5	17.5	23.5	17.5	23.5	17.5
	EDGE (8PSK, 3Tx-slot)	21.7	17.44	21.7	17.44	21.7	17.44	21.7	17.44	21.7	17.44	21.7	17.44	21.7	17.44	21.7	17.44
	EDGE (8PSK, 4Tx-slot)	20.5	17.5	20.5	17.5	20.5	17.5	20.5	17.5	20.5	17.5	20.5	17.5	20.5	17.5	20.5	17.5

# FCC SAR Test Report

Mode		WWAN (DIV) Ant-1															
		Full Power		Head Standalone		Head WLAN On		Body Standalone		Body WLAN On		Extremity Standalone		Extremity WLAN On		Hotspot On	
2G Band	Power Reduction Scenario	Full Power	Full Power	Power Table-1		Power Table-2		Power Table-3		Power Table-4		Power Table-5		Power Table-6		Power Table-7	
	Tune-up Limit (dBm)	Max. Tune-up Limit (dBm)															
		Burst-Averaged	Frame-Averaged	Burst-Averaged	Frame-Averaged	Burst-Averaged	Frame-Averaged	Burst-Averaged	Frame-Averaged	Burst-Averaged	Frame-Averaged	Burst-Averaged	Frame-Averaged	Burst-Averaged	Frame-Averaged	Burst-Averaged	Frame-Averaged
GSM850	GSM (GMSK, 1Tx-slot)	33.5	24.5	33.5	24.5	33.5	24.5	33.5	24.5	33.5	24.5	33.5	24.5	33.5	24.5	33.5	24.5
	GPRS (GMSK, 1Tx-slot)	33.5	24.5	33.5	24.5	33.5	24.5	33.5	24.5	33.5	24.5	33.5	24.5	33.5	24.5	33.5	24.5
	GPRS (GMSK, 2Tx-slot)	30.5	24.5	30.5	24.5	30.5	24.5	30.5	24.5	30.5	24.5	30.5	24.5	30.5	24.5	30.5	24.5
	GPRS (GMSK, 3Tx-slot)	28.7	24.44	28.7	24.44	28.7	24.44	28.7	24.44	28.7	24.44	28.7	24.44	28.7	24.44	28.7	24.44
	GPRS (GMSK, 4Tx-slot)	27.5	24.5	27.5	24.5	27.5	24.5	27.5	24.5	27.5	24.5	27.5	24.5	27.5	24.5	27.5	24.5
	EDGE (8PSK, 1Tx-slot)	27.5	18.5	27.5	18.5	27.5	18.5	27.5	18.5	27.5	18.5	27.5	18.5	27.5	18.5	27.5	18.5
	EDGE (8PSK, 2Tx-slot)	24.5	18.5	24.5	18.5	24.5	18.5	24.5	18.5	24.5	18.5	24.5	18.5	24.5	18.5	24.5	18.5
	EDGE (8PSK, 3Tx-slot)	22.7	18.44	22.7	18.44	22.7	18.44	22.7	18.44	22.7	18.44	22.7	18.44	22.7	18.44	22.7	18.44
	EDGE (8PSK, 4Tx-slot)	21.5	18.5	21.5	18.5	21.5	18.5	21.5	18.5	21.5	18.5	21.5	18.5	21.5	18.5	21.5	18.5
GSM1900	GSM (GMSK, 1Tx-slot)	30.5	21.5	30.0	21.0	30.0	21.0	30.5	21.5	30.5	21.5	30.5	21.5	30.5	21.5	30.0	21.0
	GPRS (GMSK, 1Tx-slot)	30.5	21.5	30.0	21.0	30.0	21.0	30.5	21.5	30.5	21.5	30.5	21.5	30.5	21.5	30.0	21.0
	GPRS (GMSK, 2Tx-slot)	27.5	21.5	27.0	21.0	27.0	21.0	27.5	21.5	27.5	21.5	27.5	21.5	27.5	21.5	27.0	21.0
	GPRS (GMSK, 3Tx-slot)	25.7	21.44	25.2	20.94	25.2	20.94	25.7	21.44	25.7	21.44	25.7	21.44	25.7	21.44	25.2	20.94
	GPRS (GMSK, 4Tx-slot)	24.5	21.5	24.0	21.0	24.0	21.0	24.5	21.5	24.5	21.5	24.5	21.5	24.5	21.5	24.0	21.0
	EDGE (8PSK, 1Tx-slot)	26.5	17.5	26.5	17.5	26.5	17.5	26.5	17.5	26.5	17.5	26.5	17.5	26.5	17.5	26.5	17.5
	EDGE (8PSK, 2Tx-slot)	23.5	17.5	23.5	17.5	23.5	17.5	23.5	17.5	23.5	17.5	23.5	17.5	23.5	17.5	23.5	17.5
	EDGE (8PSK, 3Tx-slot)	21.7	17.44	21.7	17.44	21.7	17.44	21.7	17.44	21.7	17.44	21.7	17.44	21.7	17.44	21.7	17.44
	EDGE (8PSK, 4Tx-slot)	20.5	17.5	20.5	17.5	20.5	17.5	20.5	17.5	20.5	17.5	20.5	17.5	20.5	17.5	20.5	17.5

**Note:**

- SAR testing was performed on the maximum frame-averaged power mode.
- The frame-averaged power is linearly proportion to the slot number configured and it is linearly scaled the maximum burst-averaged power based on time slots. The calculated method is shown as below:

$$\text{Frame-averaged power} = 10 \times \log (\text{Burst-averaged power mW} \times \text{Slot used} / 8)$$

# FCC SAR Test Report

Mode		WWAN (Main) Ant-0							
		Full Power	Head Standalone	Head WLAN On	Body Standalone	Body WLAN On	Extremity Standalone	Extremity WLAN On	Hotspot On
3G Band	Power Reduction Scenario	Full Power	Power Table-1	Power Table-2	Power Table-3	Power Table-4	Power Table-5	Power Table-6	Power Table-7
WCDMA II	RMC 12.2K	24.5	24.5	24.5	24.5	24.5	21.5	21.5	18.5
	HSDPA Subtest-1	23.5	23.5	23.5	23.5	23.5	20.5	20.5	17.5
	HSUPA Subtest-1	23.5	23.5	23.5	23.5	23.5	20.5	20.5	17.5
	DC-HSDPA Subtest-1	23.5	23.5	23.5	23.5	23.5	20.5	20.5	17.5
WCDMA IV	RMC 12.2K	23.5	23.5	23.5	23.5	23.5	21.5	21.5	19.5
	HSDPA Subtest-1	22.5	22.5	22.5	22.5	22.5	20.5	20.5	18.5
	HSUPA Subtest-1	22.5	22.5	22.5	22.5	22.5	20.5	20.5	18.5
	DC-HSDPA Subtest-1	22.5	22.5	22.5	22.5	22.5	20.5	20.5	18.5
WCDMA V	RMC 12.2K	24.5	24.5	24.5	24.5	24.5	24.5	24.5	24.5
	HSDPA Subtest-1	23.5	23.5	23.5	23.5	23.5	23.5	23.5	23.5
	HSUPA Subtest-1	23.5	23.5	23.5	23.5	23.5	23.5	23.5	23.5
	DC-HSDPA Subtest-1	23.5	23.5	23.5	23.5	23.5	23.5	23.5	23.5

Mode		WWAN (DIV) Ant-1							
		Full Power	Head Standalone	Head WLAN On	Body Standalone	Body WLAN On	Extremity Standalone	Extremity WLAN On	Hotspot On
3G Band	Power Reduction Scenario	Full Power	Power Table-1	Power Table-2	Power Table-3	Power Table-4	Power Table-5	Power Table-6	Power Table-7
WCDMA II	RMC 12.2K	24.5	21.0	21.0	24.5	24.5	24.5	24.5	21.0
	HSDPA Subtest-1	23.5	20.0	20.0	23.5	23.5	23.5	23.5	20.0
	HSUPA Subtest-1	23.5	20.0	20.0	23.5	23.5	23.5	23.5	20.0
	DC-HSDPA Subtest-1	23.5	20.0	20.0	23.5	23.5	23.5	23.5	20.0
WCDMA IV	RMC 12.2K	23.5	22.0	22.0	23.5	23.5	23.5	23.5	22.0
	HSDPA Subtest-1	22.5	21.0	21.0	22.5	22.5	22.5	22.5	21.0
	HSUPA Subtest-1	22.5	21.0	21.0	22.5	22.5	22.5	22.5	21.0
	DC-HSDPA Subtest-1	22.5	21.0	21.0	22.5	22.5	22.5	22.5	21.0
WCDMA V	RMC 12.2K	24.5	24.5	24.5	24.5	24.5	24.5	24.5	24.5
	HSDPA Subtest-1	23.5	23.5	23.5	23.5	23.5	23.5	23.5	23.5
	HSUPA Subtest-1	23.5	23.5	23.5	23.5	23.5	23.5	23.5	23.5
	DC-HSDPA Subtest-1	23.5	23.5	23.5	23.5	23.5	23.5	23.5	23.5

# FCC SAR Test Report

Mode						WWAN (Main) Ant-0							
						Full Power	Head Standalone	Head WLAN On	Body Standalone	Body WLAN On	Extremity Standalone	Extremity WLAN On	Hotspot On
4G Band	Full Power					Full Power	Power Table-1	Power Table-2	Power Table-3	Power Table-4	Power Table-5	Power Table-6	Power Table-7
	BW (MHz)	Modulation	RB Size	RB Offset	MPR (dB)								
LTE 2	20	QPSK	1	0/49/99	0	23.5	23.5	23.5	23.5	23.5	21.5	21.5	18.0
	20	16QAM	1	0/49/99	1	22.5	22.5	22.5	22.5	22.5	21.5	21.5	18.0
	20	64QAM	1	0/49/99	2	21.5	21.5	21.5	21.5	21.5	21.5	21.5	18.0
LTE 4	20	QPSK	1	0/49/99	0	23.5	23.5	23.5	23.5	23.5	22.0	22.0	20.0
	20	16QAM	1	0/49/99	1	22.5	22.5	22.5	22.5	22.5	22.0	22.0	20.0
	20	64QAM	1	0/49/99	2	21.5	21.5	21.5	21.5	21.5	21.5	21.5	20.0
LTE 5	10	QPSK	1	0/25/49	0	23.5	23.5	23.5	23.5	23.5	23.5	23.5	23.5
	10	16QAM	1	0/25/49	1	22.5	22.5	22.5	22.5	22.5	22.5	22.5	22.5
	10	64QAM	1	0/25/49	2	21.5	21.5	21.5	21.5	21.5	21.5	21.5	21.5
LTE 7	20	QPSK	1	0/49/99	0	23.5	23.5	23.5	23.5	23.5	22.0	22.0	22.0
	20	16QAM	1	0/49/99	1	22.5	22.5	22.5	22.5	22.5	22.0	22.0	22.0
	20	64QAM	1	0/49/99	2	21.5	21.5	21.5	21.5	21.5	21.5	21.5	21.5
LTE 38	20	QPSK	1	0/49/99	0	23.5	23.5	23.5	23.5	23.5	23.5	23.5	23.5
	20	16QAM	1	0/49/99	1	22.5	22.5	22.5	22.5	22.5	22.5	22.5	22.5
	20	64QAM	1	0/49/99	2	21.5	21.5	21.5	21.5	21.5	21.5	21.5	21.5

Mode						WWAN (DIV) Ant-1							
						Full Power	Head Standalone	Head WLAN On	Body Standalone	Body WLAN On	Extremity Standalone	Extremity WLAN On	Hotspot On
4G Band	Full Power					Full Power	Power Table-1	Power Table-2	Power Table-3	Power Table-4	Power Table-5	Power Table-6	Power Table-7
	BW (MHz)	Modulation	RB Size	RB Offset	MPR (dB)								
LTE 2	20	QPSK	1	0/49/99	0	23.5	20.0	20.0	23.5	23.5	23.5	23.5	20.0
	20	16QAM	1	0/49/99	1	22.5	20.0	20.0	22.5	22.5	22.5	22.5	20.0
	20	64QAM	1	0/49/99	2	21.5	20.0	20.0	21.5	21.5	21.5	21.5	20.0
LTE 4	20	QPSK	1	0/49/99	0	23.5	22.0	22.0	23.5	23.5	23.5	23.5	22.0
	20	16QAM	1	0/49/99	1	22.5	22.0	22.0	22.5	22.5	22.5	22.5	22.0
	20	64QAM	1	0/49/99	2	21.5	21.5	21.5	21.5	21.5	21.5	21.5	21.5
LTE 5	10	QPSK	1	0/25/49	0	23.5	23.5	23.5	23.5	23.5	23.5	23.5	23.5
	10	16QAM	1	0/25/49	1	22.5	22.5	22.5	22.5	22.5	22.5	22.5	22.5
	10	64QAM	1	0/25/49	2	21.5	21.5	21.5	21.5	21.5	21.5	21.5	21.5
LTE 7	20	QPSK	1	0/49/99	0	23.5	17.5	17.5	23.5	23.5	23.5	23.5	17.5
	20	16QAM	1	0/49/99	1	22.5	17.5	17.5	22.5	22.5	22.5	22.5	17.5
	20	64QAM	1	0/49/99	2	21.5	17.5	17.5	21.5	21.5	21.5	21.5	17.5
LTE 38	20	QPSK	1	0/49/99	0	23.5	19.5	19.5	23.5	23.5	23.5	23.5	19.5
	20	16QAM	1	0/49/99	1	22.5	19.5	19.5	22.5	22.5	22.5	22.5	19.5
	20	64QAM	1	0/49/99	2	21.5	19.5	19.5	21.5	21.5	21.5	21.5	19.5



# FCC SAR Test Report

Power Reduction Scenario			WLAN 2.4GHz					
			Full Power	Head Standalone & Body Standalone & Extremity	Head WWAN On	Body WWAN On	Extremity WWAN On	Hotspot On
			Full Power	Power Table-1	Power Table-2	Power Table-3	Power Table-4	Power Table-5
Mode	Ch	Freq.	Max. Tune-up	Max. Tune-up	Max. Tune-up	Max. Tune-up	Max. Tune-up	Max. Tune-up
802.11b	1	2412	19.5	16.5	15.0	19.5	17.5	15.0
	6	2437	19.5	16.5	15.0	19.5	17.5	15.0
	11	2462	19.5	16.5	15.0	19.5	17.5	15.0
802.11g	1	2412	16.5	16.5	15.0	16.5	16.5	15.0
	6	2437	16.5	16.5	15.0	16.5	16.5	15.0
	11	2462	16.5	16.5	15.0	16.5	16.5	15.0
802.11n HT20	1	2412	16.0	16.0	15.0	16.0	16.0	15.0
	6	2437	16.0	16.0	15.0	16.0	16.0	15.0
	11	2462	16.0	16.0	15.0	16.0	16.0	15.0

Power Reduction Scenario			WLAN 5.2GHz					
			Full Power	Head Standalone & Body Standalone & Extremity	Head WWAN On	Body WWAN On	Extremity WWAN On	Hotspot On
			Full Power	Power Table-1	Power Table-2	Power Table-3	Power Table-4	Power Table-5
Mode	Ch	Freq.	Max. Tune-up	Max. Tune-up	Max. Tune-up	Max. Tune-up	Max. Tune-up	Max. Tune-up
802.11a	36	5180	17.5	12.5	12.5	12.5	12.5	12.5
	40	5200	17.5	12.5	12.5	12.5	12.5	12.5
	44	5220	17.5	12.5	12.5	12.5	12.5	12.5
	48	5240	17.5	12.5	12.5	12.5	12.5	12.5
802.11n HT20	36	5180	16.0	12.5	12.5	12.5	12.5	12.5
	40	5200	16.0	12.5	12.5	12.5	12.5	12.5
	44	5220	16.0	12.5	12.5	12.5	12.5	12.5
	48	5240	16.0	12.5	12.5	12.5	12.5	12.5
802.11n HT40	38	5190	15.5	12.5	12.5	12.5	12.5	12.5
	46	5230	15.5	12.5	12.5	12.5	12.5	12.5
802.11ac VHT80	42	5210	14.0	12.0	12.0	12.0	12.0	12.0

# FCC SAR Test Report

Power Reduction Scenario			WLAN 5.3GHz					
			Full Power	Head Standalone & Body Standalone & Extremity	Head WWAN On	Body WWAN On	Extremity WWAN On	Hotspot On
			Full Power	Power Table-1	Power Table-2	Power Table-3	Power Table-4	Power Table-5
Mode	Ch	Freq.	Max. Tune-up	Max. Tune-up	Max. Tune-up	Max. Tune-up	Max. Tune-up	Max. Tune-up
802.11a	52	5260	17.5	12.5	12.5	12.5	12.5	12.5
	56	5280	17.5	12.5	12.5	12.5	12.5	12.5
	60	5300	17.5	12.5	12.5	12.5	12.5	12.5
	64	5320	17.5	12.5	12.5	12.5	12.5	12.5
802.11n HT20	52	5260	16.5	12.5	12.5	12.5	12.5	12.5
	56	5280	16.5	12.5	12.5	12.5	12.5	12.5
	60	5300	16.5	12.5	12.5	12.5	12.5	12.5
	64	5320	16.5	12.5	12.5	12.5	12.5	12.5
802.11n HT40	54	5270	15.5	12.5	12.5	12.5	12.5	12.5
	62	5310	15.5	12.5	12.5	12.5	12.5	12.5
802.11ac VHT80	58	5290	14.0	12.0	12.0	12.0	12.0	12.0

Power Reduction Scenario			WLAN 5.6GHz					
			Full Power	Head Standalone & Body Standalone & Extremity	Head WWAN On	Body WWAN On	Extremity WWAN On	Hotspot On
			Full Power	Power Table-1	Power Table-2	Power Table-3	Power Table-4	Power Table-5
Mode	Ch	Freq.	Max. Tune-up	Max. Tune-up	Max. Tune-up	Max. Tune-up	Max. Tune-up	Max. Tune-up
802.11a	100	5500	18.5	12.5	12.5	12.5	12.5	12.5
	116	5580	18.5	12.5	12.5	12.5	12.5	12.5
	120	5600	18.5	12.5	12.5	12.5	12.5	12.5
	124	5620	18.5	12.5	12.5	12.5	12.5	12.5
	132	5660	18.5	12.5	12.5	12.5	12.5	12.5
	140	5700	18.5	12.5	12.5	12.5	12.5	12.5
	144	5720	18.5	12.5	12.5	12.5	12.5	12.5
802.11n HT20	100	5500	17.5	12.5	12.5	12.5	12.5	12.5
	116	5580	17.5	12.5	12.5	12.5	12.5	12.5
	120	5600	17.5	12.5	12.5	12.5	12.5	12.5
	124	5620	17.5	12.5	12.5	12.5	12.5	12.5
	132	5660	17.5	12.5	12.5	12.5	12.5	12.5
	140	5700	17.5	12.5	12.5	12.5	12.5	12.5
802.11n HT40	102	5510	16.5	12.5	12.5	12.5	12.5	12.5
	110	5550	16.5	12.5	12.5	12.5	12.5	12.5
	118	5590	16.5	12.5	12.5	12.5	12.5	12.5
	126	5630	16.5	12.5	12.5	12.5	12.5	12.5
	134	5670	16.5	12.5	12.5	12.5	12.5	12.5
	142	5710	16.5	12.5	12.5	12.5	12.5	12.5
802.11ac VHT80	106	5530	15.0	12.0	12.0	12.0	12.0	12.0
	122	5610	15.0	12.0	12.0	12.0	12.0	12.0
	138	5690	15.0	12.0	12.0	12.0	12.0	12.0

# FCC SAR Test Report

Power Reduction Scenario			WLAN 5.8GHz					
			Full Power	Head Standalone & Body Standalone & Extremity	Head WWAN On	Body WWAN On	Extremity WWAN On	Hotspot On
			Full Power	Power Table-1	Power Table-2	Power Table-3	Power Table-4	Power Table-5
Mode	Ch	Freq.	Max. Tune-up	Max. Tune-up	Max. Tune-up	Max. Tune-up	Max. Tune-up	Max. Tune-up
802.11a	149	5745	17.5	12.5	12.5	12.5	12.5	12.5
	153	5765	17.5	12.5	12.5	12.5	12.5	12.5
	157	5785	17.5	12.5	12.5	12.5	12.5	12.5
	161	5805	17.5	12.5	12.5	12.5	12.5	12.5
	165	5825	17.5	12.5	12.5	12.5	12.5	12.5
802.11n HT20	149	5745	16.5	12.5	12.5	12.5	12.5	12.5
	153	5765	16.5	12.5	12.5	12.5	12.5	12.5
	157	5785	16.5	12.5	12.5	12.5	12.5	12.5
	161	5805	16.5	12.5	12.5	12.5	12.5	12.5
	165	5825	16.5	12.5	12.5	12.5	12.5	12.5
802.11n HT40	151	5755	16.5	12.5	12.5	12.5	12.5	12.5
	159	5795	16.5	12.5	12.5	12.5	12.5	12.5
802.11ac VHT80	155	5775	14.0	12.0	12.0	12.0	12.0	12.0

Bluetooth			
Mode	Ch	Freq.	Max. Tune-up
BR / EDR	0	2402	12.0
	39	2441	12.0
	78	2480	12.0
LE	0	2402	6.0
	19	2440	5.5
	39	2480	6.0

# FCC SAR Test Report

## 4.6.2 Measured Conducted Power Result

The measuring conducted average power (Unit: dBm) is shown as below.

### <WWNA (Main) Ant-0 & WWAN (DIV) Ant-1\_Full Power>

Band	GSM850			GSM1900		
Channel	128	189	251	512	661	810
Frequency (MHz)	824.2	836.4	848.8	1850.2	1880.0	1909.8
<b>Maximum Burst-Averaged Output Power</b>						
GSM (GMSK, 1Tx-slot)	32.47	<b>32.68</b>	32.58	29.09	<b>29.32</b>	29.22
GPRS (GMSK, 1Tx-slot)	32.22	32.61	32.51	29.10	29.31	29.23
GPRS (GMSK, 2Tx-slot)	29.22	29.37	29.33	25.97	26.13	25.97
GPRS (GMSK, 3Tx-slot)	27.27	27.55	27.33	24.27	24.29	24.08
GPRS (GMSK, 4Tx-slot)	26.22	<b>26.33</b>	26.31	22.93	<b>22.95</b>	22.69
EDGE (8PSK, 1Tx-slot)	29.08	29.31	29.45	26.06	26.11	26.02
EDGE (8PSK, 2Tx-slot)	27.26	27.33	27.27	24.26	24.52	24.27
EDGE (8PSK, 3Tx-slot)	26.23	25.86	26.12	25.23	25.19	25.11
EDGE (8PSK, 4Tx-slot)	23.21	23.02	23.22	22.12	22.13	22.12

Band	WCDMA Band II			WCDMA Band IV			WCDMA Band V			3GPP MPR (dB)
Channel	9262	9400	9538	1312	1413	1513	4132	4182	4233	
Frequency (MHz)	1852.4	1880.0	1907.6	1712.4	1732.6	1752.6	826.4	836.4	846.6	
RMC 12.2K	22.93	<b>23.00</b>	22.97	22.04	22.05	<b>22.10</b>	23.67	23.79	<b>23.81</b>	-
HSDPA Subtest-1	21.55	21.68	21.65	20.58	20.75	20.71	21.56	21.68	21.66	0
HSDPA Subtest-2	21.83	21.89	21.81	20.72	20.87	20.86	21.69	21.79	21.77	0
HSDPA Subtest-3	21.39	21.41	21.37	20.26	20.39	20.37	21.21	21.31	21.28	0.5
HSDPA Subtest-4	21.39	21.47	21.38	20.28	20.42	20.45	21.23	21.31	21.31	0.5
DC-HSDPA Subtest-1	21.51	21.61	21.58	20.52	20.70	20.65	21.51	21.62	21.62	0
DC-HSDPA Subtest-2	21.76	21.82	21.74	20.66	20.82	20.80	21.63	21.73	21.71	0
DC-HSDPA Subtest-3	21.32	21.34	21.30	20.20	20.34	20.31	21.15	21.25	21.22	0.5
DC-HSDPA Subtest-4	21.32	21.40	21.31	20.22	20.37	20.39	21.17	21.25	21.25	0.5
HSUPA Subtest-1	22.35	22.38	22.35	21.25	21.38	21.35	22.35	22.43	22.47	0
HSUPA Subtest-2	20.37	20.41	20.36	19.26	19.41	19.38	20.39	20.47	20.51	2
HSUPA Subtest-3	21.38	21.41	21.39	20.26	20.38	20.37	21.37	21.47	21.46	1
HSUPA Subtest-4	20.38	20.43	20.38	19.27	19.41	19.37	20.41	20.47	20.51	2
HSUPA Subtest-5	22.41	22.46	22.41	21.27	21.41	21.38	22.41	22.51	22.53	0

# FCC SAR Test Report

LTE Band 2																	
BW	MCS Index	RB Size	RB Offset	Low	Mid	High	3GPP MPR (dB)	BW	MCS Index	RB Size	RB Offset	Low	Mid	High	3GPP MPR (dB)		
		Channel		18700	18900	19100				Channel		18675	18900	19125			
		Frequency (MHz)		1860.0	1880.0	1900.0				Frequency (MHz)		1857.5	1880.0	1902.5			
20M	QPSK	1	0	22.14	22.00	21.92	0	15M	QPSK	1	0	22.13	21.96	21.84	0		
		1	50	22.06	21.92	21.84	0			1	37	22.02	21.89	21.78	0		
		1	99	21.98	21.84	21.76	0			1	74	21.96	21.83	21.72	0		
		50	0	21.01	20.87	20.79	1			36	0	20.95	20.82	20.78	1		
		50	25	21.15	21.01	20.93	1			36	19	21.14	20.99	20.88	1		
		50	50	21.08	20.94	20.86	1			36	39	21.00	20.87	20.84	1		
	16QAM	100	0	21.07	20.93	20.85	1		75	0	21.06	20.89	20.82	1			
		1	0	21.49	21.35	21.27	1		16QAM	1	0	21.46	21.34	21.21	1		
		1	50	21.34	21.20	21.12	1			1	37	21.30	21.15	21.10	1		
		1	99	21.31	21.17	21.09	1			1	74	21.25	21.15	21.06	1		
		50	0	20.30	20.16	20.08	2			36	0	20.28	20.08	20.07	2		
		50	25	20.30	20.16	20.08	2			36	19	20.22	20.12	20.03	2		
	50	50	20.25	20.11	20.03	2	36			39	20.22	20.05	20.01	2			
	64QAM	100	0	20.21	20.07	19.99	2		75	0	20.20	20.02	19.91	2			
		64QAM	1	0	20.35	20.21	20.13		2	1	0	20.29	20.18	20.09	2		
			1	50	20.29	20.15	20.07		2	1	37	20.27	20.08	20.02	2		
			1	99	20.32	20.18	20.10		2	1	74	20.26	20.10	20.08	2		
			50	0	19.41	19.27	19.19		3	36	0	19.40	19.25	19.11	3		
			50	25	19.43	19.29	19.21		3	36	19	19.36	19.21	19.15	3		
	50		50	19.40	19.26	19.18	3		36	39	19.38	19.25	19.14	3			
	100	0	19.44	19.30	19.22	3	75		0	19.42	19.22	19.21	3				
	10M	QPSK	1	0	22.06	21.96	21.87		0	5M	QPSK	1	0	22.09	21.93	21.87	0
			1	24	22.04	21.84	21.83		0			1	12	22.04	21.84	21.82	0
			1	49	21.90	21.80	21.71		0			1	24	21.93	21.76	21.75	0
25			0	20.98	20.81	20.77	1	12	0			20.97	20.82	20.74	1		
25			12	21.13	20.94	20.88	1	12	6			21.07	21.00	20.88	1		
25			25	21.02	20.86	20.84	1	12	13			21.04	20.89	20.85	1		
16QAM		50	0	21.06	20.91	20.77	1	25	0		21.01	20.91	20.80	1			
		16QAM	1	0	21.42	21.27	21.21	1	1		0	21.42	21.30	21.25	1		
			1	24	21.31	21.14	21.10	1	1		12	21.26	21.18	21.07	1		
			1	49	21.29	21.10	21.04	1	1		24	21.29	21.09	21.07	1		
			25	0	20.24	20.08	20.06	2	12		0	20.22	20.10	20.00	2		
			25	12	20.28	20.08	20.07	2	12		6	20.24	20.14	20.02	2		
25			25	20.17	20.07	19.98	2	12	13		20.18	20.06	20.01	2			
64QAM		50	0	20.19	19.99	19.98	2	25	0		20.15	20.00	19.94	2			
		64QAM	1	0	20.27	20.17	20.08	2	1		0	20.28	20.16	20.11	2		
			1	24	20.26	20.09	20.05	2	1		12	20.21	20.13	20.01	2		
			1	49	20.30	20.11	20.05	2	1		24	20.24	20.17	20.08	2		
			25	0	19.35	19.19	19.17	3	12		0	19.37	19.22	19.11	3		
			25	12	19.42	19.27	19.13	3	12		6	19.35	19.28	19.19	3		
25			25	19.35	19.18	19.12	3	12	13		19.36	19.21	19.10	3			
50		0	19.43	19.24	19.20	3	25	0	19.38		19.28	19.19	3				
3M		QPSK	1	0	22.08	21.98	21.86	0	1.4M		QPSK	1	0	22.06	21.96	21.87	0
			1	7	21.99	21.87	21.82	0				1	2	22.03	21.86	21.82	0
			1	14	21.92	21.77	21.71	0				1	5	21.96	21.77	21.71	0
	8		0	20.94	20.82	20.77	1	3		0		21.95	21.79	21.77	0		
	8		3	21.07	20.99	20.87	1	3		1		22.14	21.99	21.85	0		
	8		7	21.00	20.93	20.84	1	3		3		22.03	21.86	21.80	0		
	16QAM	15	0	21.03	20.88	20.77	1	6		0	21.06	20.87	20.83	1			
		16QAM	1	0	21.41	21.34	21.25	1		1	0	21.44	21.28	21.22	1		
			1	7	21.29	21.15	21.08	1		1	2	21.32	21.12	21.10	1		
			1	14	21.29	21.09	21.08	1		1	5	21.26	21.09	21.08	1		
			8	0	20.22	20.12	20.03	2		3	0	21.26	21.11	21.03	1		
			8	3	20.27	20.10	20.06	2		3	1	21.22	21.15	21.03	1		
	8		7	20.23	20.04	19.98	2	3		3	21.21	21.06	21.02	1			
	64QAM	15	0	20.15	19.99	19.97	2	6		0	20.15	20.05	19.94	2			
		64QAM	1	0	20.34	20.19	20.05	2		1	0	20.28	20.16	20.11	2		
			1	7	20.24	20.07	20.01	2		1	2	20.21	20.13	20.02	2		
			1	14	20.31	20.12	20.08	2		1	5	20.30	20.10	20.08	2		
			8	0	19.36	19.25	19.12	3		3	0	20.33	20.21	20.11	2		
			8	3	19.41	19.21	19.20	3		3	1	20.37	20.27	20.15	2		
	8		7	19.32	19.22	19.13	3	3		3	20.35	20.18	20.17	2			
	15	0	19.42	19.22	19.21	3	6	0		19.40	19.25	19.17	3				

# FCC SAR Test Report

LTE Band 4															
BW	MCS Index	RB Size	RB Offset	Low	Mid	High	3GPP MPR (dB)	BW	MCS Index	RB Size	RB Offset	Low	Mid	High	3GPP MPR (dB)
		Channel		20050	20175	20300				Channel		20025	20175	20325	
		Frequency (MHz)		1720.0	1732.5	1745.0				Frequency (MHz)		1717.5	1732.5	1747.5	
20M	QPSK	1	0	22.01	21.97	21.98	0	15M	QPSK	1	0	22.00	21.93	21.90	0
		1	50	21.90	21.86	21.87	0			1	37	21.86	21.83	21.81	0
		1	99	21.86	21.82	21.83	0			1	74	21.84	21.81	21.79	0
		50	0	20.86	20.82	20.83	1			36	0	20.80	20.77	20.82	1
		50	25	20.85	20.81	20.82	1			36	19	20.84	20.79	20.77	1
		50	50	20.87	20.83	20.84	1			36	39	20.79	20.76	20.82	1
	100	0	20.94	20.90	20.91	1	75		0	20.93	20.86	20.88	1		
	16QAM	1	0	21.07	21.03	21.04	1		16QAM	1	0	21.04	21.02	20.98	1
		1	50	21.17	21.13	21.14	1			1	37	21.13	21.08	21.12	1
		1	99	21.27	21.23	21.24	1			1	74	21.21	21.21	21.21	1
		50	0	19.90	19.86	19.87	2			36	0	19.88	19.78	19.86	2
		50	25	19.96	19.92	19.93	2			36	19	19.88	19.88	19.88	2
		50	50	20.00	19.96	19.97	2			36	39	19.97	19.90	19.95	2
	100	0	20.02	19.98	19.99	2	75		0	20.01	19.93	19.91	2		
	64QAM	1	0	19.95	19.91	19.92	2		64QAM	1	0	19.89	19.88	19.88	2
		1	50	19.97	19.93	19.94	2			1	37	19.95	19.86	19.89	2
		1	99	19.91	19.87	19.88	2			1	74	19.85	19.79	19.86	2
		50	0	18.99	18.95	18.96	3			36	0	18.98	18.93	18.88	3
50		25	19.02	18.98	18.99	3	36	19		18.95	18.90	18.93	3		
50		50	19.01	18.97	18.98	3	36	39		18.99	18.96	18.94	3		
100	0	19.05	19.01	19.02	3	75	0	19.03	18.93	19.01	3				
10M	QPSK	1	0	21.93	21.93	21.93	0	5M	QPSK	1	0	21.96	21.90	21.93	0
		1	24	21.88	21.78	21.86	0			1	12	21.88	21.78	21.85	0
		1	49	21.78	21.78	21.78	0			1	24	21.81	21.74	21.82	0
		25	0	20.83	20.76	20.81	1			12	0	20.82	20.77	20.78	1
		25	12	20.83	20.74	20.77	1			12	6	20.77	20.80	20.77	1
		25	25	20.81	20.75	20.82	1			12	13	20.83	20.78	20.83	1
	50	0	20.93	20.88	20.83	1	25		0	20.88	20.88	20.86	1		
	16QAM	1	0	21.00	20.95	20.98	1		16QAM	1	0	21.00	20.98	21.02	1
		1	24	21.14	21.07	21.12	1			1	12	21.09	21.11	21.09	1
		1	49	21.25	21.16	21.19	1			1	24	21.25	21.15	21.22	1
		25	0	19.84	19.78	19.85	2			12	0	19.82	19.80	19.79	2
		25	12	19.94	19.84	19.92	2			12	6	19.90	19.90	19.87	2
		25	25	19.92	19.92	19.92	2			12	13	19.93	19.91	19.95	2
	50	0	20.00	19.90	19.98	2	25		0	19.96	19.91	19.94	2		
	64QAM	1	0	19.87	19.87	19.87	2		64QAM	1	0	19.88	19.86	19.90	2
		1	24	19.94	19.87	19.92	2			1	12	19.89	19.91	19.88	2
		1	49	19.89	19.80	19.83	2			1	24	19.83	19.86	19.86	2
		25	0	18.93	18.87	18.94	3			12	0	18.95	18.90	18.88	3
25		12	19.01	18.96	18.91	3	12	6		18.94	18.97	18.97	3		
25		25	18.96	18.89	18.92	3	12	13		18.97	18.92	18.90	3		
50	0	19.04	18.95	19.00	3	25	0	18.99	18.99	18.99	3				
3M	QPSK	1	0	21.95	21.95	21.92	0	1.4M	QPSK	1	0	21.93	21.93	21.93	0
		1	7	21.83	21.81	21.85	0			1	2	21.87	21.80	21.85	0
		1	14	21.80	21.75	21.78	0			1	5	21.84	21.75	21.78	0
		8	0	20.79	20.77	20.81	1			3	0	21.80	21.74	21.81	0
		8	3	20.77	20.79	20.76	1			3	1	21.84	21.79	21.74	0
		8	7	20.79	20.82	20.82	1			3	3	21.82	21.75	21.78	0
	15	0	20.90	20.85	20.83	1	6		0	20.93	20.84	20.89	1		
	16QAM	1	0	20.99	21.02	21.02	1		16QAM	1	0	21.02	20.96	20.99	1
		1	7	21.12	21.08	21.10	1			1	2	21.15	21.05	21.12	1
		1	14	21.25	21.15	21.23	1			1	5	21.22	21.15	21.23	1
		8	0	19.82	19.82	19.82	2			3	0	20.86	20.81	20.82	1
		8	3	19.93	19.86	19.91	2			3	1	20.88	20.91	20.88	1
		8	7	19.98	19.89	19.92	2			3	3	20.96	20.91	20.96	1
	15	0	19.96	19.90	19.97	2	6		0	19.96	19.96	19.94	2		
	64QAM	1	0	19.94	19.89	19.84	2		64QAM	1	0	19.88	19.86	19.90	2
		1	7	19.92	19.85	19.88	2			1	2	19.89	19.91	19.89	2
		1	14	19.90	19.81	19.86	2			1	5	19.89	19.79	19.86	2
		8	0	18.94	18.93	18.89	3			3	0	19.91	19.89	19.88	2
8		3	19.00	18.90	18.98	3	3	1		19.96	19.84	19.93	2		
8		7	18.93	18.93	18.93	3	3	3		19.96	18.89	19.91	2		
15	0	19.03	18.93	19.01	3	6	0	19.01	18.96	18.97	3				

# FCC SAR Test Report

LTE Band 5															
BW	MCS Index	RB Size	RB Offset	Low	Mid	High	3GPP MPR (dB)	BW	MCS Index	RB Size	RB Offset	Low	Mid	High	3GPP MPR (dB)
		Channel		20450	20525	20600				Channel		20425	20525	20625	
		Frequency (MHz)		829.0	836.5	844.0				Frequency (MHz)		826.5	836.5	846.5	
10M	QPSK	1	0	22.25	<b>22.30</b>	22.24	0	5M	QPSK	1	0	22.20	22.23	22.19	0
		1	24	22.21	22.26	22.20	0			1	12	22.19	22.18	22.18	0
		1	49	22.17	22.21	22.15	0			1	24	22.11	22.13	22.14	0
		25	0	21.34	<b>21.39</b>	21.33	1			12	0	21.30	21.34	21.28	1
		25	12	21.33	21.38	21.32	1			12	6	21.25	21.37	21.27	1
		25	25	21.30	21.35	21.29	1			12	13	21.26	21.30	21.28	1
	50	0	21.31	<b>21.36</b>	21.30	1	25		0	21.25	21.34	21.25	1		
	16QAM	1	0	21.49	<b>21.54</b>	21.48	1		16QAM	1	0	21.42	21.49	21.46	1
		1	24	21.47	21.52	21.46	1			1	12	21.39	21.50	21.41	1
		1	49	21.43	21.48	21.42	1			1	24	21.41	21.40	21.40	1
		25	0	20.50	20.55	20.49	2			12	0	20.42	20.49	20.41	2
		25	12	20.46	20.51	20.45	2			12	6	20.40	20.49	20.39	2
		25	25	20.45	20.50	20.44	2			12	13	20.38	20.45	20.42	2
	50	0	20.43	20.48	20.42	2	25		0	20.37	20.41	20.37	2		
	64QAM	1	0	20.56	<b>20.61</b>	20.55	2		64QAM	1	0	20.49	20.56	20.53	2
		1	24	20.54	20.59	20.53	2			1	12	20.46	<b>20.57</b>	20.47	2
		1	49	20.47	20.48	20.42	2			1	24	20.35	20.47	20.40	2
		25	0	19.43	19.48	19.42	3			12	0	19.39	19.43	19.34	3
		25	12	19.39	19.44	19.38	3			12	6	19.31	19.43	19.36	3
		25	25	19.41	19.46	19.40	3			12	13	19.37	19.41	19.32	3
	50	0	19.37	19.42	19.36	3	25		0	19.31	19.40	19.33	3		
BW	MCS Index	RB Size	RB Offset	Low	Mid	High	3GPP MPR (dB)	BW	MCS Index	RB Size	RB Offset	Low	Mid	High	3GPP MPR (dB)
		Channel		20415	20525	20635				Channel		20407	20525	20643	
		Frequency (MHz)		825.5	836.5	847.5				Frequency (MHz)		824.7	836.5	848.3	
3M	QPSK	1	0	22.19	22.28	22.18	0	1.4M	QPSK	1	0	22.17	22.26	22.19	0
		1	7	22.14	22.21	22.18	0			1	2	22.18	22.20	22.18	0
		1	14	22.10	22.14	22.10	0			1	5	22.14	22.14	22.10	0
		8	0	21.27	21.34	21.31	1			3	0	22.28	22.31	22.31	0
		8	3	21.25	21.36	21.26	1			3	1	22.32	<b>22.36</b>	22.24	0
		8	7	21.22	21.34	21.27	1			3	3	22.25	22.27	22.23	0
	15	0	21.27	21.31	21.22	1	6		0	21.30	21.30	21.28	1		
	16QAM	1	0	21.41	21.53	21.46	1		16QAM	1	0	21.44	21.47	21.43	1
		1	7	21.42	21.47	21.42	1			1	2	21.45	21.44	21.44	1
		1	14	21.41	21.40	21.41	1			1	5	21.38	21.40	21.41	1
		8	0	20.42	20.51	20.44	2			3	0	21.46	<b>21.50</b>	21.44	1
		8	3	20.43	20.45	20.43	2			3	1	21.38	<b>21.50</b>	21.40	1
		8	7	20.43	20.43	20.39	2			3	3	21.41	21.45	21.43	1
	15	0	20.37	20.40	20.40	2	6		0	20.37	20.46	20.37	2		
	64QAM	1	0	20.55	<b>20.59</b>	20.47	2		64QAM	1	0	20.49	20.56	20.53	2
		1	7	20.49	20.51	20.47	2			1	2	20.46	<b>20.57</b>	20.48	2
		1	14	20.42	20.42	20.40	2			1	5	20.41	20.40	20.40	2
		8	0	19.38	19.46	19.35	3			3	0	20.35	20.42	20.34	2
		8	3	19.37	19.36	19.37	3			3	1	20.33	20.42	20.32	2
		8	7	19.33	19.42	19.35	3			3	3	20.36	20.38	20.39	2
	15	0	19.35	19.34	19.35	3	6		0	19.33	19.37	19.31	3		

# FCC SAR Test Report

LTE Band 7															
BW	MCS Index	RB Size	RB Offset	Low	Mid	High	3GPP MPR (dB)	BW	MCS Index	RB Size	RB Offset	Low	Mid	High	3GPP MPR (dB)
		Channel		20850	21100	21350				Channel		20825	21100	21375	
		Frequency (MHz)		2510.0	2535.0	2560.0				Frequency (MHz)		2507.5	2535.0	2562.5	
20M	QPSK	1	0	22.24	22.36	22.25	0	15M	QPSK	1	0	22.23	22.32	22.17	0
		1	50	22.29	22.41	22.30	0			1	37	22.25	22.38	22.24	0
		1	99	22.16	22.28	22.17	0			1	74	22.14	22.27	22.13	0
		50	0	21.21	21.33	21.22	1			36	0	21.15	21.28	21.21	1
		50	25	21.23	21.35	21.26	1			36	19	21.22	21.33	21.19	1
		50	50	21.25	21.37	21.26	1			36	39	21.17	21.30	21.24	1
	100	0	21.25	21.37	21.26	1	75		0	21.24	21.33	21.23	1		
	16QAM	1	0	21.53	21.65	21.54	1		16QAM	1	0	21.50	21.64	21.48	1
		1	50	21.48	21.60	21.49	1			1	37	21.44	21.55	21.47	1
		1	99	21.47	21.59	21.48	1			1	74	21.41	21.57	21.45	1
		50	0	20.20	20.32	20.21	2			36	0	20.18	20.24	20.20	2
		50	25	20.23	20.35	20.24	2			36	19	20.15	20.31	20.19	2
		50	50	20.23	20.35	20.24	2			36	39	20.20	20.29	20.22	2
	100	0	20.22	20.34	20.23	2	75		0	20.21	20.29	20.15	2		
	64QAM	1	0	20.23	20.35	20.24	2		64QAM	1	0	20.17	20.32	20.20	2
		1	50	20.26	20.38	20.27	2			1	37	20.24	20.31	20.22	2
		1	99	20.20	20.32	20.21	2			1	74	20.14	20.24	20.19	2
		50	0	19.33	19.45	19.34	3			36	0	19.32	19.43	19.26	3
		50	25	19.36	19.48	19.37	3			36	19	19.29	19.40	19.31	3
		50	50	19.32	19.44	19.33	3			36	39	19.30	19.43	19.29	3
	100	0	19.38	19.50	19.39	3	75		0	19.36	19.42	19.38	3		
BW	MCS Index	RB Size	RB Offset	Low	Mid	High	3GPP MPR (dB)	BW	MCS Index	RB Size	RB Offset	Low	Mid	High	3GPP MPR (dB)
		Channel		20800	21100	21400				Channel		20775	21100	21425	
		Frequency (MHz)		2505.0	2535.0	2565.0				Frequency (MHz)		2502.5	2535.0	2567.5	
10M	QPSK	1	0	22.16	22.32	22.20	0	5M	QPSK	1	0	22.19	22.29	22.20	0
		1	24	22.27	22.33	22.29	0			1	12	22.27	22.33	22.28	0
		1	49	22.08	22.24	22.12	0			1	24	22.11	22.20	22.16	0
		25	0	21.18	21.27	21.20	1			12	0	21.17	21.28	21.17	1
		25	12	21.21	21.28	21.19	1			12	6	21.15	21.34	21.19	1
		25	25	21.19	21.29	21.24	1			12	13	21.21	21.32	21.25	1
	50	0	21.24	21.35	21.18	1	25		0	21.19	21.35	21.21	1		
	16QAM	1	0	21.46	21.57	21.48	1		16QAM	1	0	21.46	21.60	21.52	1
		1	24	21.45	21.54	21.47	1			1	12	21.40	21.58	21.44	1
		1	49	21.45	21.52	21.43	1			1	24	21.45	21.51	21.46	1
		25	0	20.14	20.24	20.19	2			12	0	20.12	20.26	20.13	2
		25	12	20.21	20.27	20.23	2			12	6	20.17	20.33	20.18	2
		25	25	20.15	20.31	20.19	2			12	13	20.16	20.30	20.22	2
	50	0	20.20	20.26	20.22	2	25		0	20.16	20.27	20.18	2		
	64QAM	1	0	20.15	20.31	20.19	2		64QAM	1	0	20.16	20.30	20.22	2
		1	24	20.23	20.32	20.25	2			1	12	20.18	20.36	20.21	2
		1	49	20.18	20.25	20.16	2			1	24	20.12	20.31	20.19	2
		25	0	19.27	19.37	19.32	3			12	0	19.29	19.40	19.26	3
		25	12	19.35	19.46	19.29	3			12	6	19.28	19.47	19.35	3
		25	25	19.27	19.36	19.27	3			12	13	19.28	19.39	19.25	3
	50	0	19.37	19.44	19.37	3	25		0	19.32	19.48	19.36	3		



# FCC SAR Test Report

LTE Band 38																	
BW	MCS Index	RB Size	RB Offset	Low	Mid	High	3GPP MPR (dB)	BW	MCS Index	RB Size	RB Offset	Low	Mid	High	3GPP MPR (dB)		
		Channel		37850	38000	38150				Channel		37825	38000	38175			
		Frequency (MHz)		2580	2595	2610				Frequency (MHz)		2577.5	2595	2612.5			
20M	QPSK	1	0	22.62	22.45	22.56	0	15M	QPSK	1	0	22.61	22.41	22.48	0		
		1	50	22.50	22.33	22.44	0			1	37	22.46	22.30	22.38	0		
		1	99	22.49	22.32	22.43	0			1	74	22.47	22.31	22.39	0		
		50	0	21.50	21.33	21.44	1			36	0	21.44	21.28	21.43	1		
		50	25	21.54	21.37	21.48	1			36	19	21.53	21.35	21.43	1		
		50	50	21.51	21.34	21.45	1			36	39	21.43	21.27	21.43	1		
	100	0	21.54	21.37	21.48	1	75		0	21.53	21.33	21.45	1				
	16QAM	1	0	21.56	21.39	21.50	1		16QAM	1	0	21.53	21.38	21.44	1		
		1	50	21.50	21.33	21.44	1			1	37	21.46	21.28	21.42	1		
		1	99	21.48	21.31	21.42	1			1	74	21.42	21.29	21.39	1		
		50	0	20.55	20.38	20.49	2			36	0	20.53	20.30	20.48	2		
		50	25	20.54	20.37	20.48	2			36	19	20.46	20.33	20.43	2		
		50	50	20.50	20.33	20.44	2			36	39	20.47	20.27	20.42	2		
	100	0	20.51	20.34	20.45	2	75		0	20.50	20.29	20.37	2				
	64QAM	1	0	20.59	20.42	20.53	2		64QAM	1	0	20.53	20.39	20.49	2		
		1	50	20.54	20.37	20.48	2			1	37	20.52	20.30	20.43	2		
		1	99	20.60	20.43	20.54	2			1	74	20.54	20.35	20.52	2		
		50	0	19.55	19.38	19.49	3			36	0	19.54	19.36	19.41	3		
		50	25	19.52	19.35	19.46	3			36	19	19.45	19.27	19.40	3		
		50	50	19.56	19.39	19.50	3			36	39	19.54	19.38	19.46	3		
	100	0	19.58	19.41	19.52	3	75		0	19.56	19.33	19.51	3				
	10M	QPSK	1	0	22.54	22.41	22.51		0	5M	QPSK	1	0	22.57	22.38	22.51	0
			1	24	22.48	22.25	22.43		0			1	12	22.48	22.25	22.42	0
			1	49	22.41	22.28	22.38		0			1	24	22.44	22.24	22.42	0
25			0	21.47	21.27	21.42	1	12	0			21.46	21.28	21.39	1		
25			12	21.52	21.30	21.43	1	12	6			21.46	21.36	21.43	1		
25			25	21.45	21.26	21.43	1	12	13			21.47	21.29	21.44	1		
50		0	21.53	21.35	21.40	1	25	0	21.48		21.35	21.43	1				
16QAM		1	0	21.49	21.31	21.44	1	16QAM	1		0	21.49	21.34	21.48	1		
		1	24	21.47	21.27	21.42	1		1		12	21.42	21.31	21.39	1		
		1	49	21.46	21.24	21.37	1		1		24	21.46	21.23	21.40	1		
		25	0	20.49	20.30	20.47	2		12		0	20.47	20.32	20.41	2		
		25	12	20.52	20.29	20.47	2		12		6	20.48	20.35	20.42	2		
		25	25	20.42	20.29	20.39	2		12		13	20.43	20.28	20.42	2		
50		0	20.49	20.26	20.44	2	25	0	20.45		20.27	20.40	2				
64QAM		1	0	20.51	20.38	20.48	2	64QAM	1		0	20.52	20.37	20.51	2		
		1	24	20.51	20.31	20.46	2		1		12	20.46	20.35	20.42	2		
		1	49	20.58	20.36	20.49	2		1		24	20.52	20.42	20.52	2		
		25	0	19.49	19.30	19.47	3		12		0	19.51	19.33	19.41	3		
		25	12	19.51	19.33	19.38	3		12		6	19.44	19.34	19.44	3		
		25	25	19.51	19.31	19.44	3		12		13	19.52	19.34	19.42	3		
50		0	19.57	19.35	19.50	3	25	0	19.52		19.39	19.49	3				

# FCC SAR Test Report

## <WWAN (DIV) Ant-1\_Head Standalone (Power Table-1) & Head WLAN On (Power Table-2)>

Band	GSM1900		
Channel	512	661	810
Frequency (MHz)	1850.2	1880.0	1909.8
<b>Maximum Burst-Averaged Output Power</b>			
GSM (GMSK, 1Tx-slot)	28.61	<b>28.78</b>	28.71
GPRS (GMSK, 1Tx-slot)	28.63	28.77	28.69
GPRS (GMSK, 2Tx-slot)	25.51	25.71	25.68
GPRS (GMSK, 3Tx-slot)	23.58	23.86	23.75
GPRS (GMSK, 4Tx-slot)	22.39	<b>22.79</b>	22.56
EDGE (8PSK, 1Tx-slot)	25.01	25.29	25.18
EDGE (8PSK, 2Tx-slot)	23.44	23.72	23.61
EDGE (8PSK, 3Tx-slot)	25.11	25.33	25.23
EDGE (8PSK, 4Tx-slot)	22.03	22.24	22.14

Band	WCDMA Band II			WCDMA Band IV			3GPP MPR (dB)
Channel	9262	9400	9538	1312	1413	1513	
Frequency (MHz)	1852.4	1880.0	1907.6	1712.4	1732.6	1752.6	
RMC 12.2K	19.67	<b>19.87</b>	19.71	20.79	20.81	<b>20.92</b>	-
HSDPA Subtest-1	18.66	18.71	18.63	19.73	19.76	19.74	0
HSDPA Subtest-2	18.71	<b>18.77</b>	18.71	19.79	19.79	<b>19.81</b>	0
HSDPA Subtest-3	18.15	18.29	18.19	19.27	19.33	19.29	0.5
HSDPA Subtest-4	18.16	18.28	18.15	19.25	19.31	19.27	0.5
DC-HSDPA Subtest-1	18.63	18.64	18.57	19.69	19.70	19.72	0
DC-HSDPA Subtest-2	18.62	18.70	18.64	19.75	19.73	19.79	0
DC-HSDPA Subtest-3	18.11	18.22	18.13	19.23	19.27	19.27	0.5
DC-HSDPA Subtest-4	18.13	18.21	18.05	19.21	19.25	19.25	0.5
HSUPA Subtest-1	18.63	18.72	18.68	19.62	19.77	19.77	0
HSUPA Subtest-2	16.67	16.74	16.71	17.61	17.70	17.73	2
HSUPA Subtest-3	17.11	17.21	17.31	18.59	18.74	18.74	1
HSUPA Subtest-4	16.59	16.66	16.63	17.63	17.72	17.73	2
HSUPA Subtest-5	18.62	18.70	18.66	19.70	19.70	19.80	0

# FCC SAR Test Report

LTE Band 2															
BW	MCS Index	RB Size	RB Offset	Low	Mid	High	3GPP MPR (dB)	BW	MCS Index	RB Size	RB Offset	Low	Mid	High	3GPP MPR (dB)
		Channel		18700	18900	19100				Channel		18675	18900	19125	
		Frequency (MHz)		1860.0	1880.0	1900.0				Frequency (MHz)		1857.5	1880.0	1902.5	
20M	QPSK	1	0	18.93	18.87	18.82	0	15M	QPSK	1	0	18.91	18.87	18.77	0
		1	50	18.89	18.83	18.79	0			1	37	18.86	18.74	18.77	0
		1	99	18.85	18.79	18.75	0			1	74	18.76	18.73	18.66	0
		50	0	18.89	18.83	18.79	0			36	0	18.88	18.77	18.73	0
		50	25	18.91	18.85	18.81	0			36	19	18.86	18.83	18.70	0
		50	50	18.88	18.82	18.78	0			36	39	18.78	18.74	18.68	0
	100	0	18.87	18.81	18.77	0	75		0	18.84	18.73	18.68	0		
	16QAM	1	0	18.74	18.68	18.64	0		16QAM	1	0	18.64	18.67	18.58	0
		1	50	18.87	18.81	18.77	0			1	37	18.79	18.77	18.76	0
		1	99	18.89	18.83	18.79	0			1	74	18.89	18.82	18.75	0
		50	0	18.69	18.63	18.59	0			36	0	18.60	18.54	18.53	0
		50	25	18.73	18.67	18.63	0			36	19	18.67	18.65	18.61	0
		50	50	18.65	18.59	18.55	0			36	39	18.61	18.49	18.50	0
	100	0	18.62	18.56	18.52	0	75		0	18.62	18.51	18.50	0		
	64QAM	1	0	18.71	18.65	18.61	0		64QAM	1	0	18.70	18.62	18.61	0
		1	50	18.82	18.76	18.72	0			1	37	18.79	18.76	18.65	0
		1	99	18.81	18.75	18.71	0			1	74	18.80	18.75	18.64	0
		50	0	18.69	18.63	18.59	0			36	0	18.63	18.57	18.51	0
50		25	18.69	18.63	18.59	0	36	19		18.62	18.60	18.53	0		
50		50	18.63	18.57	18.53	0	36	39		18.61	18.56	18.53	0		
100	0	18.70	18.64	18.60	0	75	0	18.69	18.62	18.54	0				
10M	QPSK	1	0	18.91	18.68	18.69	0	5M	QPSK	1	0	18.73	18.70	18.79	0
		1	24	18.78	18.62	18.64	0			1	12	18.79	18.78	18.51	0
		1	49	18.67	18.69	18.54	0			1	24	18.77	18.60	18.59	0
		25	0	18.84	18.79	18.74	0			12	0	18.77	18.68	18.63	0
		25	12	18.74	18.77	18.69	0			12	6	18.80	18.67	18.72	0
		25	25	18.82	18.65	18.58	0			12	13	18.86	18.61	18.54	0
	50	0	18.74	18.76	18.53	0	25		0	18.80	18.72	18.55	0		
	16QAM	1	0	18.60	18.54	18.49	0		16QAM	1	0	18.68	18.61	18.54	0
		1	24	18.73	18.62	18.62	0			1	12	18.74	18.64	18.53	0
		1	49	18.76	18.70	18.68	0			1	24	18.66	18.74	18.68	0
		25	0	18.56	18.42	18.53	0			12	0	18.50	18.44	18.48	0
		25	12	18.61	18.52	18.47	0			12	6	18.62	18.48	18.53	0
		25	25	18.54	18.45	18.38	0			12	13	18.59	18.51	18.47	0
	50	0	18.59	18.51	18.35	0	25		0	18.58	18.42	18.49	0		
	64QAM	1	0	18.58	18.55	18.45	0		64QAM	1	0	18.51	18.54	18.50	0
		1	24	18.78	18.64	18.62	0			1	12	18.71	18.66	18.52	0
		1	49	18.68	18.68	18.70	0			1	24	18.71	18.53	18.63	0
		25	0	18.60	18.57	18.45	0			12	0	18.49	18.56	18.37	0
25		12	18.63	18.53	18.48	0	12	6		18.55	18.46	18.41	0		
25		25	18.55	18.55	18.43	0	12	13		18.46	18.53	18.51	0		
50	0	18.67	18.52	18.57	0	25	0	18.52	18.52	18.46	0				
3M	QPSK	1	0	18.83	18.71	18.68	0	1.4M	QPSK	1	0	18.83	18.73	18.72	0
		1	7	18.69	18.59	18.67	0			1	2	18.75	18.70	18.68	0
		1	14	18.77	18.63	18.60	0			1	5	18.74	18.66	18.65	0
		8	0	18.74	18.80	18.79	0			3	0	18.85	18.78	18.67	0
		8	3	18.75	18.64	18.73	0			3	1	18.73	18.74	18.63	0
		8	7	18.71	18.63	18.59	0			3	3	18.73	18.72	18.54	0
	15	0	18.79	18.73	18.56	0	6		0	18.72	18.62	18.71	0		
	16QAM	1	0	18.59	18.55	18.58	0		16QAM	1	0	18.65	18.55	18.55	0
		1	7	18.71	18.71	18.60	0			1	2	18.68	18.67	18.69	0
		1	14	18.80	18.74	18.61	0			1	5	18.75	18.69	18.66	0
		8	0	18.68	18.52	18.46	0			3	0	18.68	18.53	18.44	0
		8	3	18.57	18.49	18.48	0			3	1	18.56	18.65	18.56	0
		8	7	18.53	18.40	18.41	0			3	3	18.62	18.47	18.46	0
	15	0	18.45	18.43	18.44	0	6		0	18.40	18.47	18.37	0		
	64QAM	1	0	18.55	18.41	18.51	0		64QAM	1	0	18.67	18.65	18.42	0
		1	7	18.60	18.53	18.63	0			1	2	18.73	18.63	18.50	0
		1	14	18.67	18.65	18.58	0			1	5	18.68	18.64	18.60	0
		8	0	18.59	18.53	18.34	0			3	0	18.62	18.53	18.59	0
8		3	18.64	18.54	18.47	0	3	1		18.47	18.57	18.40	0		
8		7	18.47	18.52	18.39	0	3	3		18.54	18.53	18.40	0		
15	0	18.56	18.51	18.58	0	6	0	18.53	18.62	18.40	0				

# FCC SAR Test Report

LTE Band 4															
BW	MCS Index	RB Size	RB Offset	Low	Mid	High	3GPP MPR (dB)	BW	MCS Index	RB Size	RB Offset	Low	Mid	High	3GPP MPR (dB)
		Channel		20050	20175	20300				Channel		20025	20175	20325	
		Frequency (MHz)		1720.0	1732.5	1745.0				Frequency (MHz)		1717.5	1732.5	1747.5	
20M	QPSK	1	0	20.73	20.71	20.69	0	15M	QPSK	1	0	20.69	20.67	20.69	0
		1	50	20.71	20.69	20.66	0			1	37	20.62	20.67	20.59	0
		1	99	20.68	20.66	20.63	0			1	74	20.63	20.61	20.59	0
		50	0	20.66	20.64	20.61	0			36	0	20.56	20.58	20.54	0
		50	25	20.61	20.59	20.56	0			36	19	20.63	20.61	20.65	0
		50	50	20.70	20.68	20.65	0			36	39	20.51	20.59	20.56	0
	100	0	20.68	20.66	20.63	0	75		0	20.60	20.64	20.58	0		
	16QAM	1	0	20.58	20.56	20.53	0		1	0	20.53	20.55	20.47	0	
		1	50	20.69	20.67	20.64	0		1	37	20.62	20.59	20.62	0	
		1	99	20.51	20.49	20.46	0		1	74	20.51	20.39	20.37	0	
		50	0	20.18	20.16	20.13	0.5		36	0	20.16	20.16	20.10	0.5	
		50	25	20.13	20.11	20.08	0.5		36	19	20.05	20.03	20.03	0.5	
		50	50	20.15	20.13	20.10	0.5		36	39	20.15	20.07	20.09	0.5	
	100	0	20.10	20.08	20.05	0.5	75		0	20.08	20.10	20.09	0.5		
	64QAM	1	0	20.57	20.55	20.52	0.5		1	0	20.47	20.49	20.46	0.5	
		1	50	20.64	20.62	20.59	0.5		1	37	20.61	20.55	20.55	0.5	
		1	99	20.48	20.46	20.43	0.5		1	74	20.40	20.46	20.39	0.5	
		50	0	20.11	20.09	20.06	1.5		36	0	20.07	20.04	20.02	1.5	
50		25	20.08	20.06	20.03	1.5	36	19	20.05	20.15	20.13	1.5			
50		50	20.06	20.04	20.07	1.5	36	39	20.01	20.15	20.11	1.5			
100	0	20.08	20.04	20.01	1.5	75	0	20.06	20.01	20.07	1.5				
10M	QPSK	1	0	20.68	20.56	20.62	0	5M	QPSK	1	0	20.60	20.49	20.43	0
		1	24	20.68	20.59	20.46	0			1	12	20.54	20.57	20.47	0
		1	49	20.59	20.49	20.52	0			1	24	20.47	20.48	20.34	0
		25	0	20.58	20.46	20.47	0			12	0	20.50	20.50	20.36	0
		25	12	20.59	20.61	20.62	0			12	6	20.56	20.56	20.56	0
		25	25	20.50	20.54	20.34	0			12	13	20.57	20.43	20.43	0
	50	0	20.55	20.43	20.50	0	25		0	20.63	20.48	20.51	0		
	16QAM	1	0	20.41	20.45	20.34	0		1	0	20.52	20.44	20.44	0	
		1	24	20.54	20.53	20.49	0		1	12	20.60	20.57	20.63	0	
		1	49	20.33	20.45	20.39	0		1	24	20.34	20.45	20.44	0	
		25	0	20.09	20.03	20.12	0.5		12	0	20.09	20.03	20.12	0.5	
		25	12	20.17	20.09	20.11	0.5		12	6	20.03	20.04	20.09	0.5	
		25	25	20.08	20.13	20.01	0.5		12	13	20.04	20.18	20.22	0.5	
	50	0	20.07	20.19	20.17	0.5	25		0	20.13	20.19	20.03	0.5		
	64QAM	1	0	20.48	20.51	20.46	0.5		1	0	20.32	20.49	20.34	0.5	
		1	24	20.41	20.52	20.47	0.5		1	12	20.56	20.46	20.50	0.5	
		1	49	20.39	20.32	20.33	0.5		1	24	20.27	20.40	20.33	0.5	
		25	0	20.06	20.01	20.11	1.5		12	0	20.09	20.13	20.19	1.5	
25		12	20.01	20.07	20.13	1.5	12	6	20.12	20.11	20.07	1.5			
25		25	20.19	20.12	20.07	1.5	12	13	20.09	20.13	20.07	1.5			
50	0	20.21	20.23	20.12	1.5	25	0	20.19	20.22	20.15	1.5				
3M	QPSK	1	0	20.57	20.63	20.57	0	1.4M	QPSK	1	0	20.60	20.58	20.57	0
		1	7	20.61	20.64	20.43	0			1	2	20.60	20.61	20.46	0
		1	14	20.50	20.47	20.47	0			1	5	20.64	20.49	20.56	0
		8	0	20.52	20.54	20.47	0			3	0	20.50	20.60	20.47	0
		8	3	20.61	20.58	20.50	0			3	1	20.60	20.52	20.51	0
		8	7	20.52	20.47	20.44	0			3	3	20.50	20.57	20.52	0
	15	0	20.55	20.54	20.54	0	6		0	20.56	20.53	20.45	0		
	16QAM	1	0	20.46	20.41	20.44	0		1	0	20.43	20.45	20.45	0	
		1	7	20.55	20.50	20.49	0		1	2	20.60	20.56	20.50	0	
		1	14	20.43	20.47	20.36	0		1	5	20.37	20.30	20.42	0	
		8	0	20.13	20.22	20.09	0.5		3	0	20.03	20.10	20.04	0	
		8	3	20.06	20.07	20.13	0.5		3	1	20.09	20.11	20.13	0	
		8	7	20.19	20.11	20.28	0.5		3	3	20.15	20.05	20.12	0	
	15	0	20.12	20.02	20.23	0.5	6		0	20.22	20.06	20.09	0.5		
	64QAM	1	0	20.48	20.47	20.42	0.5		1	0	20.35	20.51	20.30	0.5	
		1	7	20.54	20.49	20.38	0.5		1	2	20.41	20.58	20.47	0.5	
		1	14	20.38	20.26	20.41	0.5		1	5	20.34	20.42	20.38	0.5	
		8	0	20.01	20.18	20.13	1.5		3	0	20.31	20.33	20.40	0.5	
8		3	20.01	20.22	20.13	1.5	3	1	20.29	20.13	20.16	0.5			
8		7	20.13	20.03	20.19	1.5	3	3	20.05	20.10	20.04	0.5			
15	0	20.02	20.22	20.31	1.5	6	0	20.11	20.19	20.05	1.5				

# FCC SAR Test Report

LTE Band 7																	
BW	MCS Index	RB Size	RB Offset	Low	Mid	High	3GPP MPR (dB)	BW	MCS Index	RB Size	RB Offset	Low	Mid	High	3GPP MPR (dB)		
		Channel		20850	21100	21350				Channel		20825	21100	21375			
		Frequency (MHz)		2510.0	2535.0	2560.0				Frequency (MHz)		2507.5	2535.0	2562.5			
20M	QPSK	1	0	16.23	16.54	16.37	0	15M	QPSK	1	0	16.17	16.50	16.39	0		
		1	50	16.30	16.62	16.40	0			1	37	16.21	16.49	16.37	0		
		1	99	16.17	16.38	16.27	0			1	74	16.17	16.37	16.24	0		
		50	0	16.27	16.48	16.37	0			36	0	16.21	16.47	16.34	0		
		50	25	16.22	16.43	16.32	0			36	19	16.28	16.45	16.41	0		
		50	50	16.31	16.52	16.41	0			36	39	16.21	16.35	16.32	0		
		100	0	16.12	16.33	16.22	0			75	0	16.05	16.23	16.15	0		
	16QAM	1	0	16.27	16.48	16.37	0		16QAM	1	0	16.17	16.38	16.35	0		
		1	50	16.21	16.42	16.31	0			1	37	16.11	16.40	16.23	0		
		1	99	16.21	16.42	16.31	0			1	74	16.17	16.37	16.21	0		
		50	0	16.11	16.32	16.21	0			36	0	16.01	16.31	16.21	0		
		50	25	16.17	16.38	16.27	0			36	19	16.10	16.35	16.23	0		
		50	50	16.18	16.39	16.28	0			36	39	16.10	16.39	16.27	0		
		100	0	16.13	16.34	16.23	0			75	0	16.09	16.24	16.22	0		
	64QAM	1	0	16.23	16.44	16.33	0		64QAM	1	0	16.21	16.40	16.25	0		
		1	50	16.20	16.41	16.30	0			1	37	16.11	16.39	16.25	0		
		1	99	16.31	16.39	16.33	0			1	74	16.29	16.31	16.33	0		
		50	0	16.21	16.42	16.31	0			36	0	16.13	16.36	16.21	0		
		50	25	16.17	16.38	16.27	0			36	19	16.16	16.34	16.25	0		
		50	50	16.20	16.41	16.30	0			36	39	16.10	16.39	16.23	0		
		100	0	16.13	16.34	16.23	0			75	0	16.03	16.30	16.18	0		
	10M	QPSK	1	0	16.08	16.45	16.34		0	5M	QPSK	1	0	16.12	16.51	16.21	0
			1	24	16.20	16.46	16.27		0			1	12	16.16	16.32	16.14	0
			1	49	16.10	16.33	16.11		0			1	24	16.02	16.18	16.16	0
25			0	16.20	16.40	16.26	0	12	0			16.13	16.38	16.12	0		
25			12	16.27	16.41	16.17	0	12	6			16.19	16.37	16.35	0		
25			25	16.10	16.32	16.14	0	12	13			16.13	16.29	16.07	0		
50			0	15.95	16.27	16.14	0	25	0			16.05	16.31	16.03	0		
16QAM		1	0	16.17	16.38	16.16	0	16QAM	1		0	16.03	16.27	16.23	0		
		1	24	16.12	16.31	16.10	0		1		12	16.04	16.25	16.22	0		
		1	49	16.05	16.28	16.07	0		1		24	16.00	16.33	16.14	0		
		25	0	16.03	16.26	16.11	0		12		0	16.10	16.27	15.98	0		
		25	12	15.96	16.18	16.17	0		12		6	15.93	16.19	16.18	0		
		25	25	16.15	16.25	16.16	0		12		13	16.03	16.22	16.21	0		
		50	0	15.97	16.18	16.10	0		25		0	16.05	16.17	16.18	0		
64QAM		1	0	16.13	16.42	16.23	0	64QAM	1		0	16.16	16.34	16.26	0		
		1	24	16.02	16.36	16.12	0		1		12	16.17	16.32	16.16	0		
		1	49	16.22	16.27	16.16	0		1		24	16.24	16.25	16.12	0		
		25	0	16.18	16.31	16.18	0		12		0	16.16	16.19	16.23	0		
		25	12	16.01	16.18	16.11	0		12		6	15.95	16.28	16.25	0		
		25	25	16.03	16.24	16.25	0		12		13	16.03	16.20	16.17	0		
		50	0	15.99	16.12	16.18	0		25		0	15.90	16.18	16.09	0		

# FCC SAR Test Report

## LTE Band 38

BW	MCS Index	RB Size	RB Offset	Low	Mid	High	3GPP MPR (dB)	BW	MCS Index	RB Size	RB Offset	Low	Mid	High	3GPP MPR (dB)		
		Channel		37850	38000	38150				Channel		37825	38000	38175			
		Frequency (MHz)		2580	2595	2610				Frequency (MHz)		2577.5	2595	2612.5			
20M	QPSK	1	0	18.11	17.91	17.93	0	15M	QPSK	1	0	18.06	17.84	17.87	0		
		1	50	18.05	17.85	17.80	0			1	37	18.00	17.85	17.80	0		
		1	99	17.93	17.73	17.68	0			1	74	17.93	17.71	17.63	0		
		50	0	18.06	17.86	17.81	0			36	0	18.04	17.79	17.80	0		
		50	25	18.08	17.88	17.83	0			36	19	18.07	17.80	17.75	0		
		50	50	18.06	17.86	17.81	0			36	39	17.99	17.85	17.76	0		
	100	0	18.07	17.87	17.82	0	75		0	18.02	17.87	17.81	0				
	16QAM	1	0	18.03	17.83	17.78	0		1	0	17.96	17.81	17.75	0			
		1	50	18.05	17.85	17.80	0		1	37	18.00	17.79	17.77	0			
		1	99	17.94	17.74	17.69	0		1	74	17.91	17.65	17.65	0			
		50	0	17.96	17.76	17.71	0		36	0	17.86	17.69	17.65	0			
		50	25	17.94	17.74	17.69	0		36	19	17.91	17.64	17.69	0			
		50	50	17.86	17.66	17.61	0		36	39	17.85	17.61	17.58	0			
	100	0	17.88	17.68	17.63	0	75		0	17.88	17.60	17.60	0				
	64QAM	1	0	17.93	17.73	17.68	0		1	0	17.87	17.68	17.60	0			
		1	50	18.02	17.82	17.77	0		1	37	17.95	17.73	17.73	0			
		1	99	18.03	17.83	17.78	0		1	74	17.93	17.77	17.68	0			
		50	0	17.99	17.79	17.74	0		36	0	17.93	17.72	17.69	0			
		50	25	18.02	17.82	17.77	0		36	19	17.98	17.75	17.68	0			
		50	50	18.05	17.85	17.80	0		36	39	17.99	17.83	17.80	0			
	100	0	17.97	17.77	17.72	0	75		0	17.89	17.72	17.71	0				
	BW	MCS Index	RB Size	RB Offset	Low	Mid	High		3GPP MPR (dB)	BW	MCS Index	RB Size	RB Offset	Low	Mid	High	3GPP MPR (dB)
			Channel		37800	38000	38200					Channel		37775	38000	38225	
			Frequency (MHz)		2575	2595	2615					Frequency (MHz)		2572.5	2595	2617.5	
10M	QPSK	1	0	17.95	17.75	17.76	0	5M	QPSK	1	0	17.97	17.82	17.74	0		
		1	24	17.88	17.77	17.75	0			1	12	17.80	17.77	17.56	0		
		1	49	17.73	17.55	17.63	0			1	24	17.85	17.62	17.69	0		
		25	0	17.94	17.75	17.64	0			12	0	17.86	17.77	17.61	0		
		25	12	18.01	17.65	17.70	0			12	6	18.06	17.83	17.52	0		
		25	25	17.97	17.67	17.70	0			12	13	17.89	17.68	17.65	0		
	50	0	17.92	17.79	17.77	0	25		0	17.93	17.65	17.53	0				
	16QAM	1	0	17.90	17.79	17.76	0		1	0	17.89	17.64	17.60	0			
		1	24	17.91	17.81	17.60	0		1	12	18.04	17.75	17.70	0			
		1	49	17.82	17.62	17.65	0		1	24	17.88	17.68	17.57	0			
		25	0	17.87	17.63	17.58	0		12	0	17.84	17.61	17.56	0			
		25	12	17.71	17.63	17.59	0		12	6	17.88	17.57	17.53	0			
		25	25	17.69	17.61	17.66	0		12	13	17.69	17.59	17.54	0			
	50	0	17.68	17.53	17.78	0	25		0	17.73	17.51	17.62	0				
	64QAM	1	0	17.84	17.54	17.56	0		1	0	17.80	17.62	17.56	0			
		1	24	17.85	17.75	17.64	0		1	12	17.91	17.69	17.57	0			
		1	49	17.97	17.62	17.60	0		1	24	17.87	17.67	17.60	0			
		25	0	17.89	17.60	17.59	0		12	0	17.83	17.58	17.52	0			
		25	12	17.87	17.82	17.60	0		12	6	17.88	17.66	17.54	0			
		25	25	17.93	17.74	17.68	0		12	13	17.98	17.69	17.68	0			
	50	0	17.89	17.74	17.63	0	25		0	17.87	17.71	17.57	0				

# FCC SAR Test Report

## <WWNA (Main) Ant-0\_Extremity Standalone (Power Table-5) & Extremity WLAN On (Power Table-6)>

Band Channel	WCDMA Band II			WCDMA Band IV			3GPP MPR (dB)
	9262 Frequency (MHz)	9400	9538	1312	1413	1513	
RMC 12.2K	1852.4	1880.0	1907.6	1712.4	1732.6	1752.6	-
HSDPA Subtest-1	19.95	<b>20.02</b>	19.98	19.87	19.98	<b>20.01</b>	0
HSDPA Subtest-2	18.96	19.01	18.94	18.53	18.95	18.96	0
HSDPA Subtest-3	18.99	19.03	18.96	18.88	19.02	18.97	0
HSDPA Subtest-4	18.55	18.57	18.50	18.42	18.56	18.52	0.5
HSDPA Subtest-4	18.53	18.59	18.52	18.39	18.53	18.47	0.5
DC-HSDPA Subtest-1	18.92	18.97	18.88	18.51	18.92	18.92	0
DC-HSDPA Subtest-2	18.95	18.98	18.83	18.81	18.95	18.89	0
DC-HSDPA Subtest-3	18.48	18.53	18.43	18.33	18.52	18.45	0.5
DC-HSDPA Subtest-4	18.45	18.52	18.41	18.31	18.46	18.43	0.5
HSUPA Subtest-1	19.32	19.37	19.30	19.21	19.35	19.33	0
HSUPA Subtest-2	17.30	17.35	17.28	17.25	17.38	17.35	2
HSUPA Subtest-3	18.33	18.38	18.31	18.21	18.35	18.32	1
HSUPA Subtest-4	17.31	17.36	17.29	17.21	17.35	17.32	2
HSUPA Subtest-5	19.31	19.36	19.29	19.19	19.33	19.30	0

# FCC SAR Test Report

LTE Band 2															
BW	MCS Index	RB Size	RB Offset	Low	Mid	High	3GPP MPR (dB)	BW	MCS Index	RB Size	RB Offset	Low	Mid	High	3GPP MPR (dB)
		Channel		18700	18900	19100				Channel		18675	18900	19125	
		Frequency (MHz)		1860.0	1880.0	1900.0				Frequency (MHz)		1857.5	1880.0	1902.5	
20M	QPSK	1	0	20.69	20.65	20.63	0	15M	QPSK	1	0	20.61	20.60	20.62	0
		1	50	20.65	20.61	20.58	0			1	37	20.61	20.55	20.55	0
		1	99	20.61	20.56	20.53	0			1	74	20.54	20.52	20.47	0
		50	0	20.55	20.51	20.49	0			36	0	20.46	20.42	20.41	0
		50	25	20.62	20.55	20.52	0			36	19	20.57	20.51	20.48	0
		50	50	20.55	20.48	20.46	0			36	39	20.50	20.47	20.36	0
	100	0	20.54	20.46	20.43	0	75		0	20.45	20.41	20.34	0		
	16QAM	1	0	20.67	20.61	20.59	0		16QAM	1	0	20.66	20.53	20.59	0
		1	50	20.68	20.64	20.61	0			1	37	20.66	20.63	20.57	0
		1	99	20.66	20.63	20.58	0			1	74	20.66	20.62	20.56	0
		50	0	20.65	20.60	20.56	0			36	0	20.65	20.58	20.53	0
		50	25	20.64	20.61	20.60	0			36	19	20.59	20.57	20.59	0
		50	50	20.68	20.62	20.59	0			36	39	20.64	20.54	20.58	0
	100	0	20.66	20.61	20.57	0	75		0	20.59	20.61	20.55	0		
	64QAM	1	0	20.54	20.50	20.47	0		64QAM	1	0	20.50	20.42	20.42	0
		1	50	20.67	20.64	20.60	0			1	37	20.61	20.63	20.59	0
		1	99	20.58	20.51	20.47	0			1	74	20.57	20.43	20.44	0
		50	0	19.72	19.65	19.62	0			36	0	19.64	19.59	19.55	0
50		25	19.83	19.74	19.70	0	36	19		19.78	19.67	19.65	0		
50		50	19.68	19.64	19.61	0	36	39		19.58	19.62	19.57	0		
100	0	19.70	19.66	19.62	0	75	0	19.69	19.61	19.59	0				
10M	QPSK	1	0	20.64	20.49	20.50	0	5M	QPSK	1	0	20.65	20.53	20.49	0
		1	24	20.52	20.53	20.41	0			1	12	20.57	20.50	20.36	0
		1	49	20.52	20.45	20.34	0			1	24	20.51	20.44	20.28	0
		25	0	20.33	20.48	20.25	0			12	0	20.45	20.49	20.29	0
		25	12	20.47	20.37	20.37	0			12	6	20.61	20.53	20.20	0
		25	25	20.40	20.38	20.32	0			12	13	20.37	20.30	20.27	0
	50	0	20.44	20.31	20.32	0	25		0	20.45	20.37	20.22	0		
	16QAM	1	0	20.47	20.55	20.49	0		16QAM	1	0	20.56	20.39	20.54	0
		1	24	20.45	20.57	20.47	0			1	12	20.52	20.51	20.44	0
		1	49	20.55	20.48	20.43	0			1	24	20.48	20.58	20.46	0
		25	0	20.47	20.43	20.46	0			12	0	20.53	20.42	20.48	0
		25	12	20.47	20.45	20.42	0			12	6	20.64	20.50	20.50	0
		25	25	20.59	20.49	20.45	0			12	13	20.53	20.49	20.48	0
	50	0	20.59	20.39	20.47	0	25		0	20.54	20.54	20.46	0		
	64QAM	1	0	20.54	20.28	20.32	0		64QAM	1	0	20.38	20.34	20.26	0
		1	24	20.53	20.45	20.47	0			1	12	20.61	20.49	20.46	0
		1	49	20.58	20.43	20.32	0			1	24	20.38	20.30	20.43	0
		25	0	19.58	19.53	19.52	0			12	0	19.65	19.56	19.52	0
25		12	19.70	19.52	19.51	0	12	6		19.64	19.58	19.51	0		
25		25	19.55	19.51	19.56	0	12	13		19.61	19.60	19.52	0		
50	0	19.55	19.52	19.53	0	25	0	19.59	19.52	19.62	0				
3M	QPSK	1	0	20.55	20.51	20.51	0	1.4M	QPSK	1	0	20.51	20.47	20.51	0
		1	7	20.51	20.59	20.48	0			1	2	20.61	20.43	20.39	0
		1	14	20.52	20.41	20.29	0			1	5	20.53	20.46	20.52	0
		8	0	20.40	20.28	20.37	0			3	0	20.41	20.48	20.40	0
		8	3	20.42	20.39	20.44	0			3	1	20.46	20.42	20.34	0
		8	7	20.42	20.43	20.38	0			3	3	20.43	20.40	20.32	0
	15	0	20.36	20.32	20.32	0	6		0	20.47	20.41	20.29	0		
	16QAM	1	0	20.49	20.40	20.47	0		16QAM	1	0	20.61	20.46	20.40	0
		1	7	20.52	20.44	20.49	0			1	2	20.60	20.57	20.48	0
		1	14	20.53	20.61	20.38	0			1	5	20.58	20.60	20.48	0
		8	0	20.49	20.46	20.52	0			3	0	20.57	20.44	20.51	0
		8	3	20.42	20.56	20.45	0			3	1	20.42	20.54	20.50	0
		8	7	20.55	20.47	20.51	0			3	3	20.63	20.53	20.58	0
	15	0	20.54	20.46	20.49	0	6		0	20.43	20.53	20.47	0		
	64QAM	1	0	20.39	20.44	20.36	0		64QAM	1	0	20.41	20.34	20.37	0
		1	7	20.47	20.43	20.40	0			1	2	20.47	20.52	20.52	0
		1	14	20.55	20.41	20.34	0			1	5	20.58	20.38	20.41	0
		8	0	19.63	19.56	19.51	0			3	0	19.56	19.54	19.60	0
8		3	19.69	19.66	19.52	0	3	1		19.68	19.57	19.63	0		
8		7	19.56	19.53	19.51	0	3	3		19.56	19.58	19.53	0		
15	0	19.53	19.51	19.52	0	6	0	19.60	19.52	19.56	0				



# FCC SAR Test Report

LTE Band 4															
BW	MCS Index	RB Size	RB Offset	Low	Mid	High	3GPP MPR (dB)	BW	MCS Index	RB Size	RB Offset	Low	Mid	High	3GPP MPR (dB)
		Channel		20050	20175	20300				Channel		20025	20175	20325	
		Frequency (MHz)		1720.0	1732.5	1745.0				Frequency (MHz)		1717.5	1732.5	1747.5	
20M	QPSK	1	0	21.09	21.08	20.93	0	15M	QPSK	1	0	21.06	21.02	20.91	0
		1	50	21.07	21.05	20.89	0			1	37	20.98	20.96	20.81	0
		1	99	21.01	21.02	20.87	0			1	74	20.96	20.96	20.84	0
		50	0	21.00	21.00	20.86	0			36	0	20.92	20.98	20.86	0
		50	25	20.96	20.97	20.82	0			36	19	20.91	20.95	20.75	0
		50	50	21.04	21.03	20.90	0			36	39	20.97	21.00	20.89	0
	16QAM	100	0	21.05	21.01	20.89	0		75	0	20.96	20.99	20.82	0	
		1	0	21.03	21.02	20.87	0		1	0	20.96	20.92	20.81	0	
		1	50	21.04	21.03	20.90	0		1	37	20.99	21.00	20.84	0	
		1	99	20.97	20.96	20.83	0		1	74	20.87	20.87	20.74	0	
		50	0	20.68	20.65	20.54	0.5		36	0	20.65	20.64	20.52	0.5	
		50	25	20.65	20.63	20.50	0.5		36	19	20.61	20.53	20.50	0.5	
	64QAM	50	50	20.58	20.57	20.41	0.5		36	39	20.55	20.47	20.35	0.5	
		100	0	20.62	20.59	20.46	0.5		75	0	20.54	20.56	20.41	0.5	
		1	0	20.67	20.66	20.51	0.5		1	0	20.64	20.62	20.49	0.5	
		1	50	20.74	20.72	20.59	0.5		1	37	20.68	20.71	20.53	0.5	
		1	99	20.52	20.52	20.40	0.5		1	74	20.47	20.46	20.39	0.5	
		50	0	19.66	19.64	19.49	1.5		36	0	19.58	19.55	19.48	1.5	
10M	QPSK	50	25	19.64	19.63	19.50	1.5	5M	QPSK	36	19	19.56	19.60	19.47	1.5
		50	50	19.60	19.58	19.47	1.5			36	39	19.53	19.50	19.38	1.5
		100	0	19.67	19.64	19.53	1.5			75	0	19.60	19.64	19.51	1.5
		1	0	20.92	20.98	20.84	0			1	0	20.99	20.95	20.62	0
		1	24	20.94	20.89	20.85	0			1	12	20.83	20.90	20.73	0
		1	49	20.87	20.88	20.73	0			1	24	20.97	20.90	20.65	0
	16QAM	25	0	20.94	20.93	20.70	0		12	0	20.89	20.84	20.57	0	
		25	12	20.87	20.76	20.69	0		12	6	20.75	20.81	20.58	0	
		25	25	20.93	20.78	20.76	0		12	13	20.86	20.83	20.69	0	
		50	0	20.93	20.82	20.84	0		25	0	20.91	20.90	20.75	0	
		1	0	20.89	20.83	20.77	0		1	0	20.87	20.89	20.79	0	
		1	24	20.85	20.95	20.68	0		1	12	20.81	20.92	20.78	0	
	64QAM	1	49	20.85	20.90	20.69	0		1	24	20.96	20.82	20.67	0	
		25	0	20.58	20.54	20.45	0.5		12	0	20.57	20.59	20.34	0.5	
		25	12	20.61	20.55	20.33	0.5		12	6	20.58	20.57	20.35	0.5	
		25	25	20.47	20.34	20.20	0.5		12	13	20.56	20.37	20.35	0.5	
		50	0	20.54	20.50	20.28	0.5		25	0	20.49	20.44	20.36	0.5	
		1	0	20.49	20.49	20.30	0.5		1	0	20.47	20.60	20.41	0.5	
3M	QPSK	1	24	20.72	20.68	20.45	0.5	1.4M	QPSK	1	12	20.60	20.61	20.52	0.5
		1	49	20.37	20.39	20.40	0.5			1	24	20.39	20.48	20.33	0.5
		25	0	19.49	19.54	19.39	1.5			12	0	19.54	19.52	19.42	1.5
		25	12	19.49	19.51	19.44	1.5			12	6	19.44	19.56	19.32	1.5
		25	25	19.50	19.46	19.40	1.5			12	13	19.39	19.49	19.30	1.5
		50	0	19.51	19.61	19.40	1.5			25	0	19.56	19.62	19.37	1.5
	16QAM	1	0	20.89	20.83	20.77	0		1	0	20.87	20.89	20.79	0	
		1	7	21.00	20.99	20.78	0		1	2	20.97	20.91	20.80	0	
		1	14	20.82	20.93	20.78	0		1	5	20.90	20.81	20.71	0	
		8	0	20.81	20.83	20.78	0		3	0	20.86	20.93	20.76	0	
		8	3	20.86	20.87	20.79	0		3	1	20.89	20.88	20.67	0	
		8	7	20.98	20.80	20.82	0		3	3	20.95	20.94	20.81	0	
	64QAM	15	0	20.85	20.92	20.71	0		6	0	20.94	20.88	20.74	0	
		1	0	20.99	20.91	20.73	0		1	0	20.88	20.77	20.70	0	
		1	7	20.89	20.83	20.75	0		1	2	20.82	20.86	20.84	0	
		1	14	20.86	20.73	20.71	0		1	5	20.83	20.76	20.72	0	
		8	0	20.53	20.56	20.52	0.5		3	0	20.58	20.49	20.37	0	
		8	3	20.50	20.52	20.35	0.5		3	1	20.56	20.53	20.31	0	
3M	16QAM	8	7	20.37	20.37	20.25	0.5	3	3	20.42	20.53	20.31	0		
		15	0	20.48	20.36	20.42	0.5	6	0	20.51	20.50	20.30	0.5		
		1	0	20.55	20.51	20.41	0.5	1	0	20.56	20.49	20.36	0.5		
		1	7	20.53	20.61	20.48	0.5	1	2	20.68	20.62	20.53	0.5		
		1	14	20.36	20.43	20.34	0.5	1	5	20.40	20.36	20.35	0.5		
		8	0	19.47	19.46	19.38	1.5	3	0	20.55	20.53	20.40	0.5		
	64QAM	8	3	19.63	19.58	19.43	1.5	3	1	20.55	20.55	20.39	0.5		
		8	7	19.41	19.40	19.42	1.5	3	3	20.46	20.46	20.33	0.5		
		15	0	19.61	19.55	19.41	1.5	6	0	19.66	19.52	19.32	1.5		

# FCC SAR Test Report

LTE Band 7																	
BW	MCS Index	RB Size	RB Offset	Low	Mid	High	3GPP MPR (dB)	BW	MCS Index	RB Size	RB Offset	Low	Mid	High	3GPP MPR (dB)		
		Channel		20850	21100	21350				Channel		20825	21100	21375			
		Frequency (MHz)		2510.0	2535.0	2560.0				Frequency (MHz)		2507.5	2535.0	2562.5			
20M	QPSK	1	0	20.85	20.98	20.89	0	15M	QPSK	1	0	20.91	21.11	20.85	0		
		1	50	20.93	21.12	20.95	0			1	37	20.93	20.90	20.90	0		
		1	99	20.81	20.87	20.74	0			1	74	20.72	20.82	20.71	0		
		50	0	20.86	20.96	20.87	0			36	0	20.80	20.89	20.77	0		
		50	25	20.83	20.93	20.87	0			36	19	20.83	20.83	20.81	0		
		50	50	20.88	20.97	20.91	0			36	39	20.90	20.93	20.72	0		
	100	0	20.87	20.96	20.89	0	75		0	20.86	20.91	20.77	0				
	16QAM	1	0	21.06	21.11	20.97	0		1	0	21.06	21.10	20.87	0			
		1	50	20.97	21.03	20.82	0		1	37	20.95	21.00	20.73	0			
		1	99	20.92	21.01	20.90	0		1	74	20.90	20.93	20.81	0			
		50	0	20.48	20.53	20.43	0.5		36	0	20.39	20.44	20.33	0.5			
		50	25	20.43	20.52	20.44	0.5		36	19	20.40	20.48	20.44	0.5			
		50	50	20.51	20.51	20.41	0.5		36	39	20.49	20.45	20.34	0.5			
	100	0	20.44	20.52	20.34	0.5	75		0	20.38	20.43	20.30	0.5				
	64QAM	1	0	20.66	20.68	20.65	0.5		1	0	20.65	20.58	20.61	0.5			
		1	50	20.48	20.55	20.38	0.5		1	37	20.38	20.52	20.37	0.5			
		1	99	20.50	20.51	20.44	0.5		1	74	20.47	20.42	20.37	0.5			
		50	0	19.54	19.57	19.53	1.5		36	0	19.64	19.61	19.53	1.5			
		50	25	19.51	19.56	19.58	1.5		36	19	19.55	19.58	19.67	1.5			
		50	50	19.55	19.55	19.52	1.5		36	39	19.52	19.64	19.53	1.5			
	100	0	19.52	19.51	19.57	1.5	75		0	19.57	19.58	19.58	1.5				
	10M	QPSK	1	0	20.90	21.07	20.79		0	5M	QPSK	1	0	20.87	20.95	20.80	0
			1	24	20.88	20.98	20.87		0			1	12	20.87	20.86	20.72	0
			1	49	20.81	20.87	20.67		0			1	24	20.80	20.74	20.63	0
25			0	20.76	20.93	20.85	0	12	0			20.83	20.82	20.86	0		
25			12	20.85	20.89	20.77	0	12	6			20.75	20.73	20.75	0		
25			25	20.83	20.95	20.69	0	12	13			20.81	20.91	20.69	0		
50		0	20.89	20.86	20.74	0	25	0	20.80		20.92	20.69	0				
16QAM		1	0	21.06	21.04	20.89	0	1	0		20.88	20.99	20.84	0			
		1	24	20.87	20.96	20.80	0	1	12		20.78	20.87	20.64	0			
		1	49	20.86	20.91	20.89	0	1	24		20.82	20.86	20.67	0			
		25	0	20.44	20.48	20.40	0.5	12	0		20.48	20.32	20.23	0.5			
		25	12	20.41	20.46	20.44	0.5	12	6		20.23	20.30	20.40	0.5			
		25	25	20.47	20.47	20.40	0.5	12	13		20.38	20.47	20.23	0.5			
50		0	20.36	20.45	20.27	0.5	25	0	20.36		20.43	20.16	0.5				
64QAM		1	0	20.64	20.66	20.62	0.5	1	0		20.64	20.58	20.52	0.5			
		1	24	20.40	20.49	20.34	0.5	1	12		20.32	20.38	20.33	0.5			
		1	49	20.48	20.45	20.35	0.5	1	24		20.37	20.34	20.32	0.5			
		25	0	19.59	19.58	19.63	1.5	12	0		19.51	19.69	19.63	1.5			
		25	12	19.57	19.65	19.64	1.5	12	6		19.54	19.56	19.64	1.5			
		25	25	19.62	19.58	19.55	1.5	12	13		19.60	19.56	19.61	1.5			
50		0	19.60	19.59	19.57	1.5	25	0	19.54		19.59	19.65	1.5				

# FCC SAR Test Report

## <WWNA (Main) Ant-0\_Hotspot On (Power Table-7)>

Band	GSM1900		
Channel	512	661	810
Frequency (MHz)	1850.2	1880.0	1909.8
<b>Maximum Burst-Averaged Output Power</b>			
GSM (GMSK, 1Tx-slot)	<b>26.89</b>	26.87	26.83
GPRS (GMSK, 1Tx-slot)	<b>26.89</b>	26.85	26.88
GPRS (GMSK, 2Tx-slot)	23.73	23.91	23.81
GPRS (GMSK, 3Tx-slot)	21.99	22.16	21.92
GPRS (GMSK, 4Tx-slot)	20.70	20.92	20.64
EDGE (8PSK, 1Tx-slot)	23.89	23.90	23.91
EDGE (8PSK, 2Tx-slot)	21.89	21.93	21.94
EDGE (8PSK, 3Tx-slot)	25.48	25.59	25.37
EDGE (8PSK, 4Tx-slot)	22.45	22.56	22.38

Band	WCDMA Band II			WCDMA Band IV			3GPP MPR (dB)
Channel	9262	9400	9538	1312	1413	1513	
Frequency (MHz)	1852.4	1880.0	1907.6	1712.4	1732.6	1752.6	
RMC 12.2K	17.49	<b>17.52</b>	17.41	18.33	18.52	<b>18.63</b>	-
HSDPA Subtest-1	16.51	16.56	16.41	17.36	17.57	17.52	0
HSDPA Subtest-2	16.44	16.55	16.62	17.65	17.75	17.77	0
HSDPA Subtest-3	16.07	16.10	16.08	17.01	17.05	17.11	0.5
HSDPA Subtest-4	16.04	16.07	16.11	17.03	17.04	17.02	0.5
DC-HSDPA Subtest-1	16.44	16.49	16.34	17.31	17.52	17.47	0
DC-HSDPA Subtest-2	16.39	16.48	16.55	17.63	17.70	17.72	0
DC-HSDPA Subtest-3	16.12	16.07	16.01	17.02	17.03	17.06	0.5
DC-HSDPA Subtest-4	16.03	16.00	16.04	17.01	17.00	16.97	0.5
HSUPA Subtest-1	15.53	15.51	15.52	17.39	17.47	17.50	0
HSUPA Subtest-2	14.52	14.46	14.51	15.61	15.57	15.63	2
HSUPA Subtest-3	16.11	16.05	16.01	16.43	16.50	16.49	1
HSUPA Subtest-4	14.63	14.52	14.53	15.44	15.51	15.55	2
HSUPA Subtest-5	16.62	16.50	16.45	17.40	17.50	17.53	0

# FCC SAR Test Report

LTE Band 2															
BW	MCS Index	RB Size	RB Offset	Low	Mid	High	3GPP MPR (dB)	BW	MCS Index	RB Size	RB Offset	Low	Mid	High	3GPP MPR (dB)
		Channel		18700	18900	19100				Channel		18675	18900	19125	
		Frequency (MHz)		1860.0	1880.0	1900.0				Frequency (MHz)		1857.5	1880.0	1902.5	
20M	QPSK	1	0	17.18	16.93	16.89	0	15M	QPSK	1	0	17.17	16.93	16.81	0
		1	50	17.04	16.91	16.87	0			1	37	17.02	16.88	16.83	0
		1	99	17.02	16.89	16.85	0			1	74	16.94	16.89	16.83	0
		50	0	17.15	17.02	16.98	0			36	0	17.06	16.92	16.94	0
		50	25	17.16	17.03	16.99	0			36	19	17.08	16.94	16.95	0
		50	50	17.08	16.95	16.91	0			36	39	17.08	16.85	16.82	0
	100	0	17.14	17.01	16.97	0	75		0	17.14	16.99	16.89	0		
	16QAM	1	0	17.14	16.84	16.80	0		16QAM	1	0	17.14	16.84	16.75	0
		1	50	17.16	16.91	16.86	0			1	37	17.11	16.82	16.76	0
		1	99	17.11	16.92	16.80	0			1	74	17.10	16.91	16.71	0
		50	0	17.00	16.82	16.76	0			36	0	16.92	16.82	16.69	0
		50	25	16.96	16.75	16.74	0			36	19	16.87	16.67	16.72	0
		50	50	16.96	16.71	16.72	0			36	39	16.91	16.68	16.64	0
	100	0	16.87	16.61	16.63	0	75		0	16.85	16.52	16.62	0		
	64QAM	1	0	16.92	16.67	16.61	0		64QAM	1	0	16.83	16.60	16.58	0
		1	50	17.06	16.83	16.84	0			1	37	16.98	16.78	16.75	0
		1	99	17.04	16.80	16.76	0			1	74	16.94	16.77	16.72	0
		50	0	17.05	16.72	16.78	0			36	0	16.99	16.68	16.71	0
50		25	17.01	16.82	16.73	0	36	19		16.93	16.75	16.63	0		
50		50	17.02	16.79	16.80	0	36	39		17.02	16.76	16.80	0		
100	0	17.04	16.80	16.71	0	75	0	16.94	16.74	16.65	0				
10M	QPSK	1	0	16.99	16.69	16.69	0	5M	QPSK	1	0	17.06	16.74	16.65	0
		1	24	16.83	16.71	16.74	0			1	12	17.04	16.80	16.65	0
		1	49	16.80	16.81	16.74	0			1	24	16.81	16.73	16.63	0
		25	0	17.15	16.84	16.77	0			12	0	17.00	16.85	16.69	0
		25	12	17.01	16.97	16.82	0			12	6	17.03	16.94	16.80	0
		25	25	16.96	16.88	16.83	0			12	13	16.88	16.86	16.66	0
	50	0	17.10	16.90	16.86	0	25		0	17.10	16.76	16.74	0		
	16QAM	1	0	17.02	16.69	16.65	0		16QAM	1	0	17.13	16.65	16.63	0
		1	24	17.00	16.72	16.72	0			1	12	17.01	16.84	16.68	0
		1	49	17.02	16.88	16.72	0			1	24	17.07	16.76	16.67	0
		25	0	16.88	16.67	16.65	0			12	0	16.85	16.76	16.73	0
		25	12	16.87	16.57	16.61	0			12	6	16.83	16.60	16.49	0
		25	25	16.80	16.59	16.58	0			12	13	16.83	16.58	16.65	0
	50	0	16.84	16.41	16.55	0	25		0	16.82	16.45	16.48	0		
	64QAM	1	0	16.85	16.52	16.53	0		64QAM	1	0	16.79	16.49	16.53	0
		1	24	16.82	16.61	16.69	0			1	12	16.86	16.74	16.75	0
		1	49	16.87	16.61	16.72	0			1	24	16.90	16.64	16.57	0
		25	0	16.94	16.57	16.66	0			12	0	16.85	16.54	16.60	0
25		12	16.81	16.63	16.67	0	12	6		16.95	16.65	16.64	0		
25		25	16.91	16.77	16.63	0	12	13		16.90	16.73	16.61	0		
50	0	16.99	16.61	16.49	0	25	0	16.87	16.74	16.49	0				
3M	QPSK	1	0	17.15	16.74	16.81	0	1.4M	QPSK	1	0	17.10	16.87	16.70	0
		1	7	16.92	16.77	16.74	0			1	2	16.88	16.75	16.79	0
		1	14	17.02	16.79	16.69	0			1	5	16.93	16.78	16.79	0
		8	0	17.07	16.89	16.91	0			3	0	17.06	16.95	16.78	0
		8	3	17.08	16.98	16.86	0			3	1	17.02	16.85	16.82	0
		8	7	16.97	16.84	16.86	0			3	3	16.94	16.85	16.74	0
	15	0	17.06	16.87	16.73	0	6		0	16.96	16.97	16.88	0		
	16QAM	1	0	17.13	16.76	16.63	0		16QAM	1	0	17.09	16.70	16.72	0
		1	7	17.12	16.81	16.68	0			1	2	17.12	16.81	16.79	0
		1	14	16.89	16.89	16.69	0			1	5	17.00	16.84	16.72	0
		8	0	16.97	16.70	16.52	0			3	0	16.87	16.62	16.65	0
		8	3	16.83	16.59	16.64	0			3	1	16.91	16.66	16.55	0
		8	7	16.75	16.65	16.58	0			3	3	16.82	16.60	16.49	0
	15	0	16.76	16.52	16.57	0	6		0	16.84	16.41	16.42	0		
	64QAM	1	0	16.84	16.61	16.54	0		64QAM	1	0	16.82	16.50	16.54	0
		1	7	16.97	16.80	16.71	0			1	2	16.91	16.73	16.66	0
		1	14	17.02	16.62	16.66	0			1	5	16.98	16.73	16.61	0
		8	0	17.00	16.69	16.59	0			3	0	16.91	16.49	16.69	0
8		3	16.95	16.63	16.61	0	3	1		16.92	16.65	16.61	0		
8		7	16.91	16.63	16.63	0	3	3		16.99	16.70	16.79	0		
15	0	16.97	16.74	16.64	0	6	0	16.85	16.67	16.58	0				

# FCC SAR Test Report

LTE Band 4															
BW	MCS Index	RB Size	RB Offset	Low	Mid	High	3GPP MPR (dB)	BW	MCS Index	RB Size	RB Offset	Low	Mid	High	3GPP MPR (dB)
		Channel		20050	20175	20300				Channel		20025	20175	20325	
		Frequency (MHz)		1720.0	1732.5	1745.0				Frequency (MHz)		1717.5	1732.5	1747.5	
20M	QPSK	1	0	18.83	18.79	18.74	0	15M	QPSK	1	0	18.80	18.69	18.69	0
		1	50	18.72	18.69	18.64	0			1	37	18.70	18.68	18.64	0
		1	99	18.58	18.55	18.50	0			1	74	18.56	18.51	18.45	0
		50	0	18.74	18.71	18.66	0			36	0	18.74	18.70	18.60	0
		50	25	18.72	18.69	18.64	0			36	19	18.74	18.77	18.68	0
		50	50	18.80	18.77	18.72	0			36	39	18.72	18.60	18.54	0
	100	0	18.71	18.68	18.63	0	75		0	18.65	18.59	18.56	0		
	16QAM	1	0	18.81	18.69	18.67	0		16QAM	1	0	18.77	18.64	18.65	0
		1	50	18.66	18.61	18.64	0			1	37	18.66	18.68	18.49	0
		1	99	18.56	18.53	18.42	0			1	74	18.41	18.42	18.35	0
		50	0	18.70	18.71	18.60	0			36	0	18.61	18.60	18.56	0
		50	25	18.76	18.70	18.66	0			36	19	18.68	18.69	18.56	0
		50	50	18.62	18.60	18.60	0			36	39	18.58	18.54	18.50	0
	100	0	18.66	18.64	18.63	0	75		0	18.67	18.54	18.63	0		
	64QAM	1	0	18.76	18.73	18.68	0		64QAM	1	0	18.73	18.62	18.66	0
		1	50	18.69	18.64	18.60	0			1	37	18.57	18.54	18.54	0
		1	99	18.48	18.50	18.42	0			1	74	18.47	18.45	18.47	0
		50	0	18.73	18.70	18.59	0			36	0	18.59	18.68	18.52	0
50		25	18.72	18.73	18.67	0	36	19		18.70	18.59	18.62	0		
50		50	18.65	18.65	18.58	0	36	39		18.69	18.65	18.54	0		
100	0	18.68	18.66	18.63	0	75	0	18.61	18.68	18.52	0				
10M	QPSK	1	0	18.68	18.74	18.45	0	5M	QPSK	1	0	18.71	18.66	18.70	0
		1	24	18.70	18.51	18.42	0			1	12	18.60	18.54	18.45	0
		1	49	18.49	18.39	18.21	0			1	24	18.42	18.39	18.32	0
		25	0	18.73	18.55	18.45	0			12	0	18.65	18.66	18.60	0
		25	12	18.65	18.68	18.51	0			12	6	18.71	18.66	18.60	0
		25	25	18.66	18.60	18.36	0			12	13	18.58	18.56	18.59	0
	50	0	18.56	18.61	18.37	0	25		0	18.63	18.47	18.48	0		
	16QAM	1	0	18.68	18.49	18.56	0		16QAM	1	0	18.75	18.58	18.65	0
		1	24	18.42	18.53	18.45	0			1	12	18.60	18.54	18.56	0
		1	49	18.37	18.45	18.37	0			1	24	18.41	18.39	18.33	0
		25	0	18.48	18.53	18.56	0			12	0	18.64	18.56	18.40	0
		25	12	18.66	18.64	18.53	0			12	6	18.53	18.64	18.54	0
		25	25	18.54	18.52	18.49	0			12	13	18.57	18.55	18.49	0
	50	0	18.50	18.53	18.55	0	25		0	18.63	18.55	18.49	0		
	64QAM	1	0	18.65	18.61	18.60	0		64QAM	1	0	18.53	18.71	18.62	0
		1	24	18.56	18.54	18.49	0			1	12	18.48	18.46	18.48	0
		1	49	18.37	18.27	18.31	0			1	24	18.41	18.46	18.25	0
		25	0	18.58	18.49	18.39	0			12	0	18.63	18.67	18.45	0
25		12	18.60	18.56	18.49	0	12	6		18.59	18.53	18.64	0		
25		25	18.56	18.60	18.49	0	12	13		18.60	18.56	18.46	0		
50	0	18.57	18.59	18.53	0	25	0	18.54	18.59	18.48	0				
3M	QPSK	1	0	18.72	18.63	18.51	0	1.4M	QPSK	1	0	18.73	18.70	18.55	0
		1	7	18.57	18.48	18.38	0			1	2	18.66	18.56	18.59	0
		1	14	18.46	18.50	18.33	0			1	5	18.42	18.44	18.42	0
		8	0	18.66	18.48	18.52	0			3	0	18.60	18.50	18.58	0
		8	3	18.69	18.68	18.38	0			3	1	18.66	18.70	18.61	0
		8	7	18.50	18.64	18.41	0			3	3	18.52	18.67	18.42	0
	15	0	18.60	18.57	18.47	0	6		0	18.70	18.56	18.56	0		
	16QAM	1	0	18.69	18.54	18.43	0		16QAM	1	0	18.71	18.47	18.55	0
		1	7	18.54	18.41	18.58	0			1	2	18.52	18.46	18.57	0
		1	14	18.38	18.53	18.27	0			1	5	18.40	18.29	18.36	0
		8	0	18.49	18.60	18.40	0			3	0	18.59	18.49	18.55	0
		8	3	18.61	18.62	18.52	0			3	1	18.67	18.55	18.51	0
		8	7	18.55	18.41	18.57	0			3	3	18.43	18.42	18.49	0
	15	0	18.53	18.58	18.44	0	6		0	18.55	18.59	18.50	0		
	64QAM	1	0	18.60	18.58	18.55	0		64QAM	1	0	18.62	18.66	18.60	0
		1	7	18.53	18.62	18.44	0			1	2	18.57	18.52	18.45	0
		1	14	18.44	18.26	18.29	0			1	5	18.37	18.46	18.36	0
		8	0	18.62	18.58	18.58	0			3	0	18.59	18.64	18.48	0
8		3	18.55	18.59	18.60	0	3	1		18.58	18.67	18.58	0		
8		7	18.50	18.52	18.50	0	3	3		18.58	18.53	18.49	0		
15	0	18.47	18.59	18.49	0	6	0	18.65	18.52	18.44	0				

# FCC SAR Test Report

LTE Band 7															
BW	MCS Index	RB Size	RB Offset	Low	Mid	High	3GPP MPR (dB)	BW	MCS Index	RB Size	RB Offset	Low	Mid	High	3GPP MPR (dB)
		Channel		20850	21100	21350				Channel		20825	21100	21375	
		Frequency (MHz)		2510.0	2535.0	2560.0				Frequency (MHz)		2507.5	2535.0	2562.5	
20M	QPSK	1	0	20.74	20.77	20.73	0	15M	QPSK	1	0	20.70	20.56	20.68	0
		1	50	20.83	20.86	20.82	0			1	37	20.69	20.77	20.81	0
		1	99	20.58	20.61	20.57	0			1	74	20.46	20.48	20.47	0
		50	0	20.78	20.81	20.77	0			36	0	20.57	20.61	20.67	0
		50	25	20.74	20.77	20.73	0			36	19	20.65	20.78	20.75	0
		50	50	20.80	20.83	20.79	0			36	39	20.62	20.64	20.60	0
	100	0	20.79	20.82	20.78	0	75		0	20.64	20.72	20.64	0		
	16QAM	1	0	20.80	20.83	20.79	0		1	0	20.67	20.66	20.70	0	
		1	50	20.81	20.84	20.80	0		1	37	20.69	20.75	20.59	0	
		1	99	20.69	20.72	20.68	0		1	74	20.52	20.57	20.49	0	
		50	0	20.35	20.38	20.34	0.5		36	0	20.20	20.30	20.20	0.5	
		50	25	20.44	20.47	20.43	0.5		36	19	20.30	20.33	20.21	0.5	
		50	50	20.31	20.34	20.30	0.5		36	39	20.24	20.29	20.18	0.5	
	100	0	20.33	20.36	20.32	0.5	75		0	20.11	20.14	20.15	0.5		
	64QAM	1	0	20.44	20.47	20.43	0.5		64QAM	1	0	20.33	20.37	20.29	0.5
		1	50	20.39	20.42	20.38	0.5			1	37	20.24	20.27	20.19	0.5
		1	99	20.30	20.33	20.29	0.5			1	74	20.09	20.26	20.25	0.5
		50	0	20.08	20.11	20.07	1.5			36	0	20.03	20.03	20.02	1.5
		50	25	20.16	20.19	20.15	1.5			36	19	20.09	20.09	20.05	1.5
		50	50	20.03	20.06	20.02	1.5			36	39	20.11	20.13	20.08	1.5
	100	0	20.06	20.09	20.05	1.5	75		0	20.09	20.19	20.12	1.5		
BW	MCS Index	RB Size	RB Offset	Low	Mid	High	3GPP MPR (dB)	BW	MCS Index	RB Size	RB Offset	Low	Mid	High	3GPP MPR (dB)
		Channel		20800	21100	21400				Channel		20775	21100	21425	
		Frequency (MHz)		2505.0	2535.0	2565.0				Frequency (MHz)		2502.5	2535.0	2567.5	
10M	QPSK	1	0	20.68	20.64	20.61	0	5M	QPSK	1	0	20.62	20.60	20.54	0
		1	24	20.72	20.67	20.62	0			1	12	20.67	20.69	20.64	0
		1	49	20.47	20.53	20.35	0			1	24	20.52	20.36	20.41	0
		25	0	20.71	20.73	20.58	0			12	0	20.61	20.72	20.67	0
		25	12	20.65	20.66	20.69	0			12	6	20.64	20.69	20.68	0
		25	25	20.55	20.63	20.65	0			12	13	20.71	20.67	20.55	0
	50	0	20.57	20.68	20.55	0	25		0	20.60	20.78	20.65	0		
	16QAM	1	0	20.69	20.74	20.63	0		16QAM	1	0	20.76	20.65	20.64	0
		1	24	20.62	20.78	20.72	0			1	12	20.64	20.67	20.74	0
		1	49	20.54	20.57	20.45	0			1	24	20.51	20.63	20.50	0
		25	0	20.29	20.32	20.18	0.5			12	0	20.19	20.22	20.28	0.5
		25	12	20.30	20.40	20.27	0.5			12	6	20.26	20.33	20.34	0.5
		25	25	20.26	20.21	20.11	0.5			12	13	20.18	20.32	20.18	0.5
	50	0	20.17	20.23	20.18	0.5	25		0	20.11	20.32	20.14	0.5		
	64QAM	1	0	20.29	20.33	20.34	0.5		64QAM	1	0	20.29	20.41	20.41	0.5
		1	24	20.31	20.33	20.33	0.5			1	12	20.34	20.35	20.23	0.5
		1	49	20.27	20.26	20.16	0.5			1	24	20.11	20.24	20.21	0.5
		25	0	20.05	20.09	20.21	1.5			12	0	20.09	20.22	20.01	1.5
		25	12	20.02	20.06	20.19	1.5			12	6	20.11	20.13	20.08	1.5
		25	25	20.11	20.11	20.17	1.5			12	13	20.12	20.19	20.13	1.5
	50	0	20.08	20.03	20.13	1.5	25		0	20.04	20.02	20.19	1.5		

# FCC SAR Test Report

## <WWNA (DVI) Ant-1\_Hotspot On (Power Table-7)>

Band	GSM1900		
Channel	512	661	810
Frequency (MHz)	1850.2	1880.0	1909.8
<b>Maximum Burst-Averaged Output Power</b>			
GSM (GMSK, 1Tx-slot)	28.61	<b>28.78</b>	28.71
GPRS (GMSK, 1Tx-slot)	28.63	28.77	28.69
GPRS (GMSK, 2Tx-slot)	25.51	25.71	25.68
GPRS (GMSK, 3Tx-slot)	23.58	23.86	23.75
GPRS (GMSK, 4Tx-slot)	22.39	22.79	22.56
EDGE (8PSK, 1Tx-slot)	25.01	25.29	25.18
EDGE (8PSK, 2Tx-slot)	23.44	23.72	23.61
EDGE (8PSK, 3Tx-slot)	25.11	25.33	25.23
EDGE (8PSK, 4Tx-slot)	22.03	22.24	22.14

Band	WCDMA Band II			WCDMA Band IV			3GPP MPR (dB)
Channel	9262	9400	9538	1312	1413	1513	
Frequency (MHz)	1852.4	1880.0	1907.6	1712.4	1732.6	1752.6	
RMC 12.2K	19.67	<b>19.87</b>	19.71	20.79	20.81	<b>20.92</b>	-
HSDPA Subtest-1	18.66	18.71	18.63	19.73	19.76	19.74	0
HSDPA Subtest-2	18.71	<b>18.77</b>	18.71	19.79	19.79	<b>19.81</b>	0
HSDPA Subtest-3	18.15	18.29	18.19	19.27	19.33	19.29	0.5
HSDPA Subtest-4	18.16	18.28	18.15	19.25	19.31	19.27	0.5
DC-HSDPA Subtest-1	18.63	18.64	18.57	19.69	19.70	19.72	0
DC-HSDPA Subtest-2	18.62	18.70	18.64	19.75	19.73	19.79	0
DC-HSDPA Subtest-3	18.11	18.22	18.13	19.23	19.27	19.27	0.5
DC-HSDPA Subtest-4	18.13	18.21	18.05	19.21	19.25	19.25	0.5
HSUPA Subtest-1	18.63	18.72	18.68	19.62	19.77	19.77	0
HSUPA Subtest-2	16.67	16.74	16.71	17.61	17.70	17.73	2
HSUPA Subtest-3	17.11	17.21	17.31	18.59	18.74	18.74	1
HSUPA Subtest-4	16.59	16.66	16.63	17.63	17.72	17.73	2
HSUPA Subtest-5	18.62	18.70	18.66	19.70	19.70	19.80	0



# FCC SAR Test Report

LTE Band 2															
BW	MCS Index	RB Size	RB Offset	Low	Mid	High	3GPP MPR (dB)	BW	MCS Index	RB Size	RB Offset	Low	Mid	High	3GPP MPR (dB)
		Channel		18700	18900	19100				Channel		18675	18900	19125	
		Frequency (MHz)		1860.0	1880.0	1900.0				Frequency (MHz)		1857.5	1880.0	1902.5	
20M	QPSK	1	0	18.93	18.87	18.82	0	15M	QPSK	1	0	18.91	18.87	18.77	0
		1	50	18.89	18.83	18.79	0			1	37	18.86	18.74	18.77	0
		1	99	18.85	18.79	18.75	0			1	74	18.76	18.73	18.66	0
		50	0	18.89	18.83	18.79	0			36	0	18.88	18.77	18.73	0
		50	25	18.91	18.85	18.81	0			36	19	18.86	18.83	18.70	0
		50	50	18.88	18.82	18.78	0			36	39	18.78	18.74	18.68	0
	100	0	18.87	18.81	18.77	0	75		0	18.84	18.73	18.68	0		
	16QAM	1	0	18.74	18.68	18.64	0		16QAM	1	0	18.64	18.67	18.58	0
		1	50	18.87	18.81	18.77	0			1	37	18.79	18.77	18.76	0
		1	99	18.89	18.83	18.79	0			1	74	18.89	18.82	18.75	0
		50	0	18.69	18.63	18.59	0			36	0	18.60	18.54	18.53	0
		50	25	18.73	18.67	18.63	0			36	19	18.67	18.65	18.61	0
		50	50	18.65	18.59	18.55	0			36	39	18.61	18.49	18.50	0
	100	0	18.62	18.56	18.52	0	75		0	18.62	18.51	18.50	0		
	64QAM	1	0	18.71	18.65	18.61	0		64QAM	1	0	18.70	18.62	18.61	0
		1	50	18.82	18.76	18.72	0			1	37	18.79	18.76	18.65	0
		1	99	18.81	18.75	18.71	0			1	74	18.80	18.75	18.64	0
		50	0	18.69	18.63	18.59	0			36	0	18.63	18.57	18.51	0
50		25	18.69	18.63	18.59	0	36	19		18.62	18.60	18.53	0		
50		50	18.63	18.57	18.53	0	36	39		18.61	18.56	18.53	0		
100	0	18.70	18.64	18.60	0	75	0	18.69	18.62	18.54	0				
10M	QPSK	1	0	18.91	18.68	18.69	0	5M	QPSK	1	0	18.73	18.70	18.79	0
		1	24	18.78	18.62	18.64	0			1	12	18.79	18.78	18.51	0
		1	49	18.67	18.69	18.54	0			1	24	18.77	18.60	18.59	0
		25	0	18.84	18.79	18.74	0			12	0	18.77	18.68	18.63	0
		25	12	18.74	18.77	18.69	0			12	6	18.80	18.67	18.72	0
		25	25	18.82	18.65	18.58	0			12	13	18.86	18.61	18.54	0
	50	0	18.74	18.76	18.53	0	25		0	18.80	18.72	18.55	0		
	16QAM	1	0	18.60	18.54	18.49	0		16QAM	1	0	18.68	18.61	18.54	0
		1	24	18.73	18.62	18.62	0			1	12	18.74	18.64	18.53	0
		1	49	18.76	18.70	18.68	0			1	24	18.66	18.74	18.68	0
		25	0	18.56	18.42	18.53	0			12	0	18.50	18.44	18.48	0
		25	12	18.61	18.52	18.47	0			12	6	18.62	18.48	18.53	0
		25	25	18.54	18.45	18.38	0			12	13	18.59	18.51	18.47	0
	50	0	18.59	18.51	18.35	0	25		0	18.58	18.42	18.49	0		
	64QAM	1	0	18.58	18.55	18.45	0		64QAM	1	0	18.51	18.54	18.50	0
		1	24	18.78	18.64	18.62	0			1	12	18.71	18.66	18.52	0
		1	49	18.68	18.68	18.70	0			1	24	18.71	18.53	18.63	0
		25	0	18.60	18.57	18.45	0			12	0	18.49	18.56	18.37	0
25		12	18.63	18.53	18.48	0	12	6		18.55	18.46	18.41	0		
25		25	18.55	18.55	18.43	0	12	13		18.46	18.53	18.51	0		
50	0	18.67	18.52	18.57	0	25	0	18.52	18.52	18.46	0				
3M	QPSK	1	0	18.83	18.71	18.68	0	1.4M	QPSK	1	0	18.83	18.73	18.72	0
		1	7	18.69	18.59	18.67	0			1	2	18.75	18.70	18.68	0
		1	14	18.77	18.63	18.60	0			1	5	18.74	18.66	18.65	0
		8	0	18.74	18.80	18.79	0			3	0	18.85	18.78	18.67	0
		8	3	18.75	18.64	18.73	0			3	1	18.73	18.74	18.63	0
		8	7	18.71	18.63	18.59	0			3	3	18.73	18.72	18.54	0
	15	0	18.79	18.73	18.56	0	6		0	18.72	18.62	18.71	0		
	16QAM	1	0	18.59	18.55	18.58	0		16QAM	1	0	18.65	18.55	18.55	0
		1	7	18.71	18.71	18.60	0			1	2	18.68	18.67	18.69	0
		1	14	18.80	18.74	18.61	0			1	5	18.75	18.69	18.66	0
		8	0	18.68	18.52	18.46	0			3	0	18.68	18.53	18.44	0
		8	3	18.57	18.49	18.48	0			3	1	18.56	18.65	18.56	0
		8	7	18.53	18.40	18.41	0			3	3	18.62	18.47	18.46	0
	15	0	18.45	18.43	18.44	0	6		0	18.40	18.47	18.37	0		
	64QAM	1	0	18.55	18.41	18.51	0		64QAM	1	0	18.67	18.65	18.42	0
		1	7	18.60	18.53	18.63	0			1	2	18.73	18.63	18.50	0
		1	14	18.67	18.65	18.58	0			1	5	18.68	18.64	18.60	0
		8	0	18.59	18.53	18.34	0			3	0	18.62	18.53	18.59	0
8		3	18.64	18.54	18.47	0	3	1		18.47	18.57	18.40	0		
8		7	18.47	18.52	18.39	0	3	3		18.54	18.53	18.40	0		
15	0	18.56	18.51	18.58	0	6	0	18.53	18.62	18.40	0				



# FCC SAR Test Report

LTE Band 4															
BW	MCS Index	RB Size	RB Offset	Low	Mid	High	3GPP MPR (dB)	BW	MCS Index	RB Size	RB Offset	Low	Mid	High	3GPP MPR (dB)
		Channel		20050	20175	20300				Channel		20025	20175	20325	
		Frequency (MHz)		1720.0	1732.5	1745.0				Frequency (MHz)		1717.5	1732.5	1747.5	
20M	QPSK	1	0	20.73	20.71	20.69	0	15M	QPSK	1	0	20.69	20.67	20.69	0
		1	50	20.71	20.69	20.66	0			1	37	20.62	20.67	20.59	0
		1	99	20.68	20.66	20.63	0			1	74	20.63	20.61	20.59	0
		50	0	20.66	20.64	20.61	0			36	0	20.56	20.58	20.54	0
		50	25	20.61	20.59	20.56	0			36	19	20.63	20.61	20.65	0
		50	50	20.70	20.68	20.65	0			36	39	20.51	20.59	20.56	0
	100	0	20.68	20.66	20.63	0	75		0	20.60	20.64	20.58	0		
	16QAM	1	0	20.58	20.56	20.53	0		1	0	20.53	20.55	20.47	0	
		1	50	20.69	20.67	20.64	0		1	37	20.62	20.59	20.62	0	
		1	99	20.51	20.49	20.46	0		1	74	20.51	20.39	20.37	0	
		50	0	20.18	20.16	20.13	0.5		36	0	20.16	20.16	20.10	0.5	
		50	25	20.13	20.11	20.08	0.5		36	19	20.05	20.03	20.03	0.5	
		50	50	20.15	20.13	20.10	0.5		36	39	20.15	20.07	20.09	0.5	
	100	0	20.10	20.08	20.05	0.5	75		0	20.08	20.10	20.09	0.5		
	64QAM	1	0	20.57	20.55	20.52	0.5		64QAM	1	0	20.47	20.49	20.46	0.5
		1	50	20.64	20.62	20.59	0.5			1	37	20.61	20.55	20.55	0.5
		1	99	20.48	20.46	20.43	0.5			1	74	20.40	20.46	20.39	0.5
		50	0	20.11	20.09	20.06	1.5			36	0	20.07	20.04	20.02	1.5
50		25	20.08	20.06	20.03	1.5	36	19		20.05	20.15	20.13	1.5		
50		50	20.06	20.04	20.07	1.5	36	39		20.01	20.15	20.11	1.5		
100	0	20.08	20.04	20.01	1.5	75	0	20.06	20.01	20.07	1.5				
10M	QPSK	1	0	20.68	20.56	20.62	0	5M	QPSK	1	0	20.60	20.49	20.43	0
		1	24	20.68	20.59	20.46	0			1	12	20.54	20.57	20.47	0
		1	49	20.59	20.49	20.52	0			1	24	20.47	20.48	20.34	0
		25	0	20.58	20.46	20.47	0			12	0	20.50	20.50	20.36	0
		25	12	20.59	20.61	20.62	0			12	6	20.56	20.56	20.56	0
		25	25	20.50	20.54	20.34	0			12	13	20.57	20.43	20.43	0
	50	0	20.55	20.43	20.50	0	25		0	20.63	20.48	20.51	0		
	16QAM	1	0	20.41	20.45	20.34	0		16QAM	1	0	20.52	20.44	20.44	0
		1	24	20.54	20.53	20.49	0			1	12	20.60	20.57	20.63	0
		1	49	20.33	20.45	20.39	0			1	24	20.34	20.45	20.44	0
		25	0	20.09	20.03	20.12	0.5			12	0	20.09	20.03	20.12	0.5
		25	12	20.17	20.09	20.11	0.5			12	6	20.03	20.04	20.09	0.5
		25	25	20.08	20.13	20.01	0.5			12	13	20.04	20.18	20.22	0.5
	50	0	20.07	20.19	20.17	0.5	25		0	20.13	20.19	20.03	0.5		
	64QAM	1	0	20.48	20.51	20.46	0.5		64QAM	1	0	20.32	20.49	20.34	0.5
		1	24	20.41	20.52	20.47	0.5			1	12	20.56	20.46	20.50	0.5
		1	49	20.39	20.32	20.33	0.5			1	24	20.27	20.40	20.33	0.5
		25	0	20.06	20.01	20.11	1.5			12	0	20.09	20.13	20.19	1.5
25		12	20.01	20.07	20.13	1.5	12	6		20.12	20.11	20.07	1.5		
25		25	20.19	20.12	20.07	1.5	12	13		20.09	20.13	20.07	1.5		
50	0	20.21	20.23	20.12	1.5	25	0	20.19	20.22	20.15	1.5				
3M	QPSK	1	0	20.57	20.63	20.57	0	1.4M	QPSK	1	0	20.60	20.58	20.57	0
		1	7	20.61	20.64	20.43	0			1	2	20.60	20.61	20.46	0
		1	14	20.50	20.47	20.47	0			1	5	20.64	20.49	20.56	0
		8	0	20.52	20.54	20.47	0			3	0	20.50	20.60	20.47	0
		8	3	20.61	20.58	20.50	0			3	1	20.60	20.52	20.51	0
		8	7	20.52	20.47	20.44	0			3	3	20.50	20.57	20.52	0
	15	0	20.55	20.54	20.54	0	6		0	20.56	20.53	20.45	0		
	16QAM	1	0	20.46	20.41	20.44	0		16QAM	1	0	20.43	20.45	20.45	0
		1	7	20.55	20.50	20.49	0			1	2	20.60	20.56	20.50	0
		1	14	20.43	20.47	20.36	0			1	5	20.37	20.30	20.42	0
		8	0	20.13	20.22	20.09	0.5			3	0	20.03	20.10	20.04	0
		8	3	20.06	20.07	20.13	0.5			3	1	20.09	20.11	20.13	0
		8	7	20.19	20.11	20.28	0.5			3	3	20.15	20.05	20.12	0
	15	0	20.12	20.02	20.23	0.5	6		0	20.22	20.06	20.09	0.5		
	64QAM	1	0	20.48	20.47	20.42	0.5		64QAM	1	0	20.35	20.51	20.30	0.5
		1	7	20.54	20.49	20.38	0.5			1	2	20.41	20.58	20.47	0.5
		1	14	20.38	20.26	20.41	0.5			1	5	20.34	20.42	20.38	0.5
		8	0	20.01	20.18	20.13	1.5			3	0	20.31	20.33	20.40	0.5
8		3	20.01	20.22	20.13	1.5	3	1		20.29	20.13	20.16	0.5		
8		7	20.13	20.03	20.19	1.5	3	3		20.05	20.10	20.04	0.5		
15	0	20.02	20.22	20.31	1.5	6	0	20.11	20.19	20.05	1.5				

# FCC SAR Test Report

LTE Band 7																	
BW	MCS Index	RB Size	RB Offset	Low	Mid	High	3GPP MPR (dB)	BW	MCS Index	RB Size	RB Offset	Low	Mid	High	3GPP MPR (dB)		
		Channel		20850	21100	21350				Channel		20825	21100	21375			
		Frequency (MHz)		2510.0	2535.0	2560.0				Frequency (MHz)		2507.5	2535.0	2562.5			
20M	QPSK	1	0	16.23	16.54	16.47	0	15M	QPSK	1	0	16.17	16.50	16.39	0		
		1	50	16.30	16.62	16.40	0			1	37	16.21	16.49	16.37	0		
		1	99	16.17	16.38	16.27	0			1	74	16.17	16.37	16.24	0		
		50	0	16.27	16.48	16.37	0			36	0	16.21	16.47	16.34	0		
		50	25	16.22	16.43	16.32	0			36	19	16.28	16.45	16.41	0		
		50	50	16.31	16.52	16.41	0			36	39	16.21	16.35	16.32	0		
	100	0	16.12	16.33	16.22	0	75		0	16.05	16.23	16.15	0				
	16QAM	1	0	16.27	16.48	16.37	0		1	0	16.17	16.38	16.35	0			
		1	50	16.21	16.42	16.31	0		1	37	16.11	16.40	16.23	0			
		1	99	16.21	16.42	16.31	0		1	74	16.17	16.37	16.21	0			
		50	0	16.11	16.32	16.21	0		36	0	16.01	16.31	16.21	0			
		50	25	16.17	16.38	16.27	0		36	19	16.10	16.35	16.23	0			
		50	50	16.18	16.39	16.28	0		36	39	16.10	16.39	16.27	0			
	100	0	16.13	16.34	16.23	0	75		0	16.09	16.24	16.22	0				
	64QAM	1	0	16.23	16.44	16.33	0		1	0	16.21	16.40	16.25	0			
		1	50	16.20	16.41	16.30	0		1	37	16.11	16.39	16.25	0			
		1	99	16.31	16.39	16.33	0		1	74	16.29	16.31	16.33	0			
		50	0	16.21	16.42	16.31	0		36	0	16.13	16.36	16.21	0			
		50	25	16.17	16.38	16.27	0		36	19	16.16	16.34	16.25	0			
		50	50	16.20	16.41	16.30	0		36	39	16.10	16.39	16.23	0			
	100	0	16.13	16.34	16.23	0	75		0	16.03	16.30	16.18	0				
	10M	QPSK	1	0	16.08	16.45	16.34		0	5M	QPSK	1	0	16.12	16.51	16.21	0
			1	24	16.20	16.46	16.27		0			1	12	16.16	16.32	16.14	0
			1	49	16.10	16.33	16.11		0			1	24	16.02	16.18	16.16	0
25			0	16.20	16.40	16.26	0	12	0			16.13	16.38	16.12	0		
25			12	16.27	16.41	16.17	0	12	6			16.19	16.37	16.35	0		
25			25	16.10	16.32	16.14	0	12	13			16.13	16.29	16.07	0		
50		0	15.95	16.27	16.14	0	25	0	16.05		16.31	16.03	0				
16QAM		1	0	16.17	16.38	16.16	0	1	0		16.03	16.27	16.23	0			
		1	24	16.12	16.31	16.10	0	1	12		16.04	16.25	16.22	0			
		1	49	16.05	16.28	16.07	0	1	24		16.00	16.33	16.14	0			
		25	0	16.03	16.26	16.11	0	12	0		16.10	16.27	15.98	0			
		25	12	15.96	16.18	16.17	0	12	6		15.93	16.19	16.18	0			
		25	25	16.15	16.25	16.16	0	12	13		16.03	16.22	16.21	0			
50		0	15.97	16.18	16.10	0	25	0	16.05		16.17	16.18	0				
64QAM		1	0	16.13	16.42	16.23	0	1	0		16.16	16.34	16.26	0			
		1	24	16.02	16.36	16.12	0	1	12		16.17	16.32	16.16	0			
		1	49	16.22	16.27	16.16	0	1	24		16.24	16.25	16.12	0			
		25	0	16.18	16.31	16.18	0	12	0		16.16	16.19	16.23	0			
		25	12	16.01	16.18	16.11	0	12	6		15.95	16.28	16.25	0			
		25	25	16.03	16.24	16.25	0	12	13		16.03	16.20	16.17	0			
50		0	15.99	16.12	16.18	0	25	0	15.90		16.18	16.09	0				

# FCC SAR Test Report

## LTE Band 38

BW	MCS Index	RB Size	RB Offset	Low	Mid	High	3GPP MPR (dB)	BW	MCS Index	RB Size	RB Offset	Low	Mid	High	3GPP MPR (dB)		
		Channel		37850	38000	38150				Channel		37825	38000	38175			
		Frequency (MHz)		2580	2595	2610				Frequency (MHz)		2577.5	2595	2612.5			
20M	QPSK	1	0	18.11	17.91	17.93	0	15M	QPSK	1	0	18.06	17.84	17.87	0		
		1	50	18.05	17.85	17.80	0			1	37	18.00	17.85	17.80	0		
		1	99	17.93	17.73	17.68	0			1	74	17.93	17.71	17.63	0		
		50	0	18.06	17.86	17.81	0			36	0	18.04	17.79	17.80	0		
		50	25	18.08	17.88	17.83	0			36	19	18.07	17.80	17.75	0		
		50	50	18.06	17.86	17.81	0			36	39	17.99	17.85	17.76	0		
	100	0	18.07	17.87	17.82	0	75		0	18.02	17.87	17.81	0				
	16QAM	1	0	18.03	17.83	17.78	0		1	0	17.96	17.81	17.75	0			
		1	50	18.05	17.85	17.80	0		1	37	18.00	17.79	17.77	0			
		1	99	17.94	17.74	17.69	0		1	74	17.91	17.65	17.65	0			
		50	0	17.96	17.76	17.71	0		36	0	17.86	17.69	17.65	0			
		50	25	17.94	17.74	17.69	0		36	19	17.91	17.64	17.69	0			
		50	50	17.86	17.66	17.61	0		36	39	17.85	17.61	17.58	0			
	100	0	17.88	17.68	17.63	0	75		0	17.88	17.60	17.60	0				
	64QAM	1	0	17.93	17.73	17.68	0		1	0	17.87	17.68	17.60	0			
		1	50	18.02	17.82	17.77	0		1	37	17.95	17.73	17.73	0			
		1	99	18.03	17.83	17.78	0		1	74	17.93	17.77	17.68	0			
		50	0	17.99	17.79	17.74	0		36	0	17.93	17.72	17.69	0			
		50	25	18.02	17.82	17.77	0		36	19	17.98	17.75	17.68	0			
		50	50	18.05	17.85	17.80	0		36	39	17.99	17.83	17.80	0			
	100	0	17.97	17.77	17.72	0	75		0	17.89	17.72	17.71	0				
	BW	MCS Index	RB Size	RB Offset	Low	Mid	High		3GPP MPR (dB)	BW	MCS Index	RB Size	RB Offset	Low	Mid	High	3GPP MPR (dB)
			Channel		37800	38000	38200					Channel		37775	38000	38225	
			Frequency (MHz)		2575	2595	2615					Frequency (MHz)		2572.5	2595	2617.5	
10M	QPSK	1	0	17.95	17.75	17.76	0	5M	QPSK	1	0	17.97	17.82	17.74	0		
		1	24	17.88	17.77	17.75	0			1	12	17.80	17.77	17.56	0		
		1	49	17.73	17.55	17.63	0			1	24	17.85	17.62	17.69	0		
		25	0	17.94	17.75	17.64	0			12	0	17.86	17.77	17.61	0		
		25	12	18.01	17.65	17.70	0			12	6	18.06	17.83	17.52	0		
		25	25	17.97	17.67	17.70	0			12	13	17.89	17.68	17.65	0		
	50	0	17.92	17.79	17.77	0	25		0	17.93	17.65	17.53	0				
	16QAM	1	0	17.90	17.79	17.76	0		1	0	17.89	17.64	17.60	0			
		1	24	17.91	17.81	17.60	0		1	12	18.04	17.75	17.70	0			
		1	49	17.82	17.62	17.65	0		1	24	17.88	17.68	17.57	0			
		25	0	17.87	17.63	17.58	0		12	0	17.84	17.61	17.56	0			
		25	12	17.71	17.63	17.59	0		12	6	17.88	17.57	17.53	0			
		25	25	17.69	17.61	17.66	0		12	13	17.69	17.59	17.54	0			
	50	0	17.68	17.53	17.78	0	25		0	17.73	17.51	17.62	0				
	64QAM	1	0	17.84	17.54	17.56	0		1	0	17.80	17.62	17.56	0			
		1	24	17.85	17.75	17.64	0		1	12	17.91	17.69	17.57	0			
		1	49	17.97	17.62	17.60	0		1	24	17.87	17.67	17.60	0			
		25	0	17.89	17.60	17.59	0		12	0	17.83	17.58	17.52	0			
		25	12	17.87	17.82	17.60	0		12	6	17.88	17.66	17.54	0			
		25	25	17.93	17.74	17.68	0		12	13	17.98	17.69	17.68	0			
	50	0	17.89	17.74	17.63	0	25		0	17.87	17.71	17.57	0				

# FCC SAR Test Report

## <BT / WLAN Ant\_Full Power>

### <WLAN 2.4G>

Mode	Channel	Frequency (MHz)	Average Power
802.11b	1	2412	18.60
	6	2437	18.75
	11	2462	19.10
802.11g	1	2412	16.22
	6	2437	16.00
	11	2462	16.08
802.11n (HT20)	1	2412	15.66
	6	2437	15.46
	11	2462	15.50

### <WLAN 5.2G>

Mode	Channel	Frequency (MHz)	Average Power
802.11a	36	5180	16.64
	40	5200	16.75
	44	5220	17.01
	48	5240	17.05
802.11n (HT20)	36	5180	15.61
	40	5200	15.63
	44	5220	15.42
	48	5240	15.87
802.11n (HT40)	38	5190	14.96
	46	5230	15.09
802.11ac (VHT80)	42	5210	13.71

### <WLAN 5.3G>

Mode	Channel	Frequency (MHz)	Average Power
802.11a	52	5260	17.05
	56	5280	17.21
	60	5300	17.25
	64	5320	17.21
802.11n (HT20)	52	5260	15.98
	56	5280	15.85
	60	5300	16.02
	64	5320	16.05
802.11n (HT40)	54	5270	15.27
	62	5310	15.41
802.11ac (VHT80)	58	5290	13.95

# FCC SAR Test Report

## <WLAN 5.6G>

Mode	Channel	Frequency (MHz)	Average Power
802.11a	100	5500	18.07
	116	5580	17.93
	120	5600	17.62
	124	5620	17.44
	132	5660	17.12
	140	5700	17.25
	144	5720	16.90
802.11n (HT20)	100	5500	17.01
	116	5580	16.96
	120	5600	16.50
	124	5620	16.30
	132	5660	16.00
	140	5700	16.03
	144	5720	16.06
802.11n (HT40)	102	5510	16.25
	110	5550	16.28
	118	5590	15.79
	126	5630	15.54
	134	5670	15.56
	142	5710	14.85
802.11ac (VHT80)	106	5530	14.84
	122	5610	14.69
	138	5690	13.79

## <WLAN 5.8G>

Mode	Channel	Frequency (MHz)	Average Power
802.11a	149	5745	17.21
	153	5765	17.32
	157	5785	17.34
	161	5805	17.42
	165	5825	17.35
802.11n (HT20)	149	5745	16.28
	153	5765	16.21
	157	5785	16.23
	161	5805	16.32
	165	5825	16.26
802.11n (HT40)	151	5755	16.13
	159	5795	16.38
802.11ac (VHT80)	155	5775	13.86

## <Bluetooth>

Mode	Channel	Frequency (MHz)	Average Power
Bluetooth EDR	0	2402	10.92
	39	2441	10.59
	78	2480	10.61
Bluetooth LE	0	2402	4.21
	19	2440	3.79
	39	2480	4.81

# FCC SAR Test Report

<BT / WLAN Ant\_ Head Standalone & Body Standalone & Extremity (Power Table-1) / Head WWAN On (Power Table-2) / Body WWAN On (Power Table-3) / Extremity WWAN On (Power Table-4) / Hotspot On (Power Table-5)>

## <WLAN 2.4G>

Mode	Channel	Frequency (MHz)	Average Power				
			Head Standalone & Body Standalone & Extremity (Power Table-1)	Head WWAN On (Power Table-2)	Body WWAN On (Power Table-3)	Extremity WWAN On (Power Table-4)	Hotspot On (Power Table-5)
802.11b	1	2412	15.57	14.21	18.60	17.10	14.06
	6	2437	15.51	14.26	18.75	17.15	14.00
	11	2462	16.09	14.76	19.10	17.45	14.56
802.11g	1	2412	16.22	14.70	16.22	16.22	14.70
	6	2437	16.00	14.24	16.00	16.00	14.24
	11	2462	16.08	14.62	16.08	16.08	14.62
802.11n (HT20)	1	2412	15.66	14.57	15.66	15.66	14.57
	6	2437	15.46	14.12	15.46	15.46	14.12
	11	2462	15.50	14.43	15.50	15.50	14.43

## <WLAN 5.2G>

Mode	Channel	Frequency (MHz)	Average Power
			Head Standalone & Body Standalone & Extremity (Power Table-1) / Head WWAN On (Power Table-2) / Body WWAN On (Power Table-3) / Extremity WWAN On (Power Table-4) / Hotspot On (Power Table-5)
802.11a	36	5180	10.90
	40	5200	11.06
	44	5220	11.17
	48	5240	11.40
802.11n (HT20)	36	5180	10.75
	40	5200	10.88
	44	5220	11.12
	48	5240	11.29
802.11n (HT40)	38	5190	11.11
	46	5230	11.46
802.11ac (VHT80)	42	5210	10.82

## <WLAN 5.3G>

Mode	Channel	Frequency (MHz)	Average Power
			Head Standalone & Body Standalone & Extremity (Power Table-1) / Head WWAN On (Power Table-2) / Body WWAN On (Power Table-3) / Extremity WWAN On (Power Table-4) / Hotspot On (Power Table-5)
802.11a	52	5260	11.58
	56	5280	11.75
	60	5300	11.77
	64	5320	11.84
802.11n (HT20)	52	5260	11.40
	56	5280	11.51
	60	5300	11.62
	64	5320	11.64
802.11n (HT40)	54	5270	11.75
	62	5310	11.92
802.11ac (VHT80)	58	5290	11.37

# FCC SAR Test Report

## <WLAN 5.6G>

Mode	Channel	Frequency (MHz)	Average Power
			Head Standalone & Body Standalone & Extremity (Power Table-1) / Head WWAN On (Power Table-2) / Body WWAN On (Power Table-3) / Extremity WWAN On (Power Table-4) / Hotspot On (Power Table-5)
802.11a	100	5500	12.10
	116	5580	12.36
	120	5600	12.31
	124	5620	12.17
	132	5660	11.91
	140	5700	11.40
	144	5720	11.45
802.11n (HT20)	100	5500	11.94
	116	5580	12.21
	120	5600	12.15
	124	5620	12.01
	132	5660	11.71
	140	5700	11.24
	144	5720	11.31
802.11n (HT40)	102	5510	12.34
	110	5550	12.49
	118	5590	12.47
	126	5630	12.27
	134	5670	11.84
	142	5710	11.57
802.11ac (VHT80)	106	5530	11.95
	122	5610	11.92
	138	5690	11.22

## <WLAN 5.8G>

Mode	Channel	Frequency (MHz)	Average Power
			Head Standalone & Body Standalone & Extremity (Power Table-1) / Head WWAN On (Power Table-2) / Body WWAN On (Power Table-3) / Extremity WWAN On (Power Table-4) / Hotspot On (Power Table-5)
802.11a	149	5745	12.01
	153	5765	11.73
	157	5785	12.17
	161	5805	11.90
	165	5825	12.19
802.11n (HT20)	149	5745	11.82
	153	5765	11.53
	157	5785	11.90
	161	5805	11.78
	165	5825	12.04
802.11n (HT40)	151	5755	12.12
	159	5795	12.24
802.11ac (VHT80)	155	5775	11.75

## <Bluetooth>

Mode	Channel	Frequency (MHz)	Average Power
Bluetooth EDR	0	2402	10.92
	39	2441	10.59
	78	2480	10.61
Bluetooth LE	0	2402	4.21
	19	2440	3.79
	39	2480	4.81

## 4.7 SAR Testing Results

### 4.7.1 SAR Test Reduction Considerations

#### <KDB 447498 D01, General RF Exposure Guidance>

Testing of other required channels within the operating mode of a frequency band is not required when the reported SAR for the mid-band or highest output power channel is:

- (1)  $\leq 0.8$  W/kg or 2.0 W/kg, for 1-g or 10-g respectively, when the transmission band is  $\leq 100$  MHz
- (2)  $\leq 0.6$  W/kg or 1.5 W/kg, for 1-g or 10-g respectively, when the transmission band is between 100 MHz and 200 MHz
- (3)  $\leq 0.4$  W/kg or 1.0 W/kg, for 1-g or 10-g respectively, when the transmission band is  $\geq 200$  MHz

When SAR is not measured at the maximum power level allowed for production units, the measured SAR will be scaled to the maximum tune-up tolerance limit to determine compliance. The scaling factor for the tune-up power is defined as maximum tune-up limit (mW) / measured conducted power (mW). The reported SAR would be calculated by measured SAR x tune-up power scaling factor.

The SAR has been measured with highest transmission duty factor supported by the test mode tools for WLAN and/or Bluetooth. When the transmission duty factor could not achieve 100%, the reported SAR will be scaled to 100% transmission duty factor to determine compliance at the maximum tune-up power. The scaling factor for the duty factor is defined as 100% / transmission duty cycle (%). The reported SAR would be calculated by measured SAR x tune-up power scaling factor x duty cycle scaling factor.

#### <KDB 941225 D01, 3G SAR Measurement Procedures>

The mode tested for SAR is referred to as the primary mode. The equivalent modes considered for SAR test reduction are denoted as secondary modes. Both primary and secondary modes must be in the same frequency band. When the maximum output power and tune-up tolerance specified for production units in a secondary mode is  $\leq 1/4$  dB higher than the primary mode or when the highest reported SAR of the primary mode is scaled by the ratio of specified maximum output power and tune-up tolerance of secondary to primary mode and the adjusted SAR is  $\leq 1.2$  W/kg, SAR measurement is not required for the secondary mode.



### <KDB 941225 D05, SAR Evaluation Considerations for LTE Devices>

#### (1) QPSK with 1 RB and 50% RB allocation

Start with the largest channel bandwidth and measure SAR, using the RB offset and required test channel combination with the highest maximum output power among RB offsets at the upper edge, middle and lower edge of each required test channel. When the reported SAR is  $\leq 0.8$  W/kg, testing of the remaining RB offset configurations and required test channels is not required; otherwise, SAR is required for the remaining required test channels and only for the RB offset configuration with the highest output power for that channel. When the reported SAR of a required test channel is  $> 1.45$  W/kg, SAR is required for all three RB offset configurations for that required test channel.

#### (2) QPSK with 100% RB allocation

SAR is not required when the highest maximum output power for 100% RB allocation is less than the highest maximum output power in 50% and 1 RB allocations and the highest reported SAR for 1 RB and 50% RB allocation are  $\leq 0.8$  W/kg. Otherwise, SAR is measured for the highest output power channel; and if the reported SAR is  $> 1.45$  W/kg, the remaining required test channels must also be tested.

#### (3) Higher order modulations

SAR is required only when the highest maximum output power for the configuration in the higher order modulation is  $> 1/2$  dB higher than the same configuration in QPSK or when the reported SAR for the QPSK configuration is  $> 1.45$  W/kg.

#### (4) Other channel bandwidth

SAR is required when the highest maximum output power of the smaller channel bandwidth is  $> 1/2$  dB higher than the equivalent channel configurations in the largest channel bandwidth configuration or the reported SAR of a configuration for the largest channel bandwidth is  $> 1.45$  W/kg.

### <Power Confirmation for SAR Test Exclusion for LTE Downlink CA>

According to KDB 941225 D05A, the uplink maximum output power below was measured with downlink CA active on the channel with highest measured maximum output power when downlink CA is inactive. The downlink SCC channel was paired with the uplink channel as normal operation. For intra-band contiguous CA, the downlink channel spacing between the component carriers was set to multiple of 300 kHz less than the nominal channel spacing per section 5.4.1A of 3GPP TS36.521. For intra-band non-contiguous CA, the downlink channel spacing between the component carriers was set to maximum separation from PCC and remain fully within the downlink transmission band. For Inter-band CA, the SCC downlink channel was set to near the middle of its transmission band.

# FCC SAR Test Report

## Power Measurements for Intra-Band Contiguous Downlink CA

### <WWNA (Main) Ant-0 & WWAN (DIV) Ant-1\_Full Power / Body Standalone (Power Table-3) / Body WLAN On (Power Table-4)>

CA Combination	PCC								SCC1				Power	
	LTE Band	BW (MHz)	UL Channel	UL Freq. (MHz)	RB Size	RB Offset	DL Channel	DL Freq. (MHz)	LTE Band	BW (MHz)	DL Channel	DL Freq. (MHz)	Tx Power withDL-CA Active (dBm)	Single Carrier Tx Power (dBm)
CA_38C	38	20	37850	2580	1	0	37850	2580	38	20	38048	2599.8	22.61	22.62
CA_7A-7A	7	20	21100	2535	1	50	3100	2655	7	20	3350	2680	22.38	22.41

### < WWAN (DIV) Ant-1\_Head Standalone (Power Table-1) / Head WLAN On (Power Table-2)>

CA Combination	PCC								SCC1				Power	
	LTE Band	BW (MHz)	UL Channel	UL Freq. (MHz)	RB Size	RB Offset	DL Channel	DL Freq. (MHz)	LTE Band	BW (MHz)	DL Channel	DL Freq. (MHz)	Tx Power withDL-CA Active (dBm)	Single Carrier Tx Power (dBm)
CA_38C	38	20	37850	2580	1	0	37850	2580	38	20	38048	2599.8	18.08	18.11
CA_7A-7A	7	20	21100	2535	1	50	3100	2655	7	20	3350	2680	16.35	16.62

### <WWNA (Main) Ant-0\_Hotspot On (Power Table-7)>

CA Combination	PCC								SCC1				Power	
	LTE Band	BW (MHz)	UL Channel	UL Freq. (MHz)	RB Size	RB Offset	DL Channel	DL Freq. (MHz)	LTE Band	BW (MHz)	DL Channel	DL Freq. (MHz)	Tx Power withDL-CA Active (dBm)	Single Carrier Tx Power (dBm)
CA_38C	38	20	37850	2580	1	0	37850	2580	38	20	38048	2599.8	22.61	22.62
CA_7A-7A	7	20	21100	2535	1	50	3100	2655	7	20	3350	2680	20.83	20.86

### <WWNA (DIV) Ant-1\_Hotspot On (Power Table-7)>

CA Combination	PCC								SCC1				Power	
	LTE Band	BW (MHz)	UL Channel	UL Freq. (MHz)	RB Size	RB Offset	DL Channel	DL Freq. (MHz)	LTE Band	BW (MHz)	DL Channel	DL Freq. (MHz)	Tx Power withDL-CA Active (dBm)	Single Carrier Tx Power (dBm)
CA_38C	38	20	37850	2580	1	0	37850	2580	38	20	38048	2599.8	18.08	18.11
CA_7A-7A	7	20	21100	2535	1	50	3100	2655	7	20	3350	2680	16.35	16.62

### <WWNA (Main) Ant-0\_Extremity Standalone (Power Table-5) / Extremity WLAN On (Power Table-6)>

CA Combination	PCC								SCC1				Power	
	LTE Band	BW (MHz)	UL Channel	UL Freq. (MHz)	RB Size	RB Offset	DL Channel	DL Freq. (MHz)	LTE Band	BW (MHz)	DL Channel	DL Freq. (MHz)	Tx Power withDL-CA Active (dBm)	Single Carrier Tx Power (dBm)
CA_38C	38	20	37850	2580	1	0	37850	2580	38	20	38048	2599.8	22.61	22.62
CA_7A-7A	7	20	21100	2535	1	50	3100	2655	7	20	3350	2680	21.11	21.12

## Summary for SAR Test Exclusion for LTE Downlink CA

Per power confirmation results in above, the uplink maximum output power with downlink CA active remains within the specified tune-up tolerance and not more than 0.25 dB higher than the maximum output power with downlink CA inactive. According to KDB 941225 D05A, the SAR test exclusion applies to LTE downlink CA operation.

# FCC SAR Test Report

## <Power Confirmation for SAR Testing for LTE Uplink CA>

The conducted power for uplink CA active was measured on the highest reported SAR configuration for each exposure condition with both two carrier components was set to largest channel bandwidth.

## <WWNA (Main) Ant-0 & WWAN (DIV) Ant-1\_Full Power>

PCC							SCC							Power	
Band	BW (MHz)	Modulation	RB Size	RB Offset	UL Channel	UL Frequency (MHz)	Band	BW (MHz)	Modulation	RB Size	RB Offset	UL Channel	UL Frequency (MHz)	Single Carrier Tx Power (dBm)	Tx Power with DL-CA Active (dBm)
7	20	QPSK	1	0	20850	2510	7	20	QPSK	1	99	21048	2529.8	22.24	14.01
			1	99						22.16	22.15				
7	20	QPSK	1	0	21001	2525.1	7	20	QPSK	1	99	21199	2544.9	22.36	13.98
			1	99						22.28	22.27				
7	20	QPSK	1	0	21152	2540.2	7	20	QPSK	1	99	21350	2560	22.25	13.93
			1	99						22.27	22.15				
38	20	QPSK	1	0	37850	2580	38	20	QPSK	1	99	38048	2599.8	22.62	14.03
			1	99						22.49	22.48				
38	20	QPSK	1	0	37901	2585.1	38	20	QPSK	1	99	38099	2604.9	22.45	14.03
			1	99						22.32	22.31				
38	20	QPSK	1	0	37952	2590.2	38	20	QPSK	1	99	38150	2610	22.56	14.08
			1	99						22.43	22.41				

## < WWAN (DIV) Ant-1\_Head Standalone (Power Table-1) / Head WLAN On (Power Table-2)>

PCC							SCC							Power	
Band	BW (MHz)	Modulation	RB Size	RB Offset	UL Channel	UL Frequency (MHz)	Band	BW (MHz)	Modulation	RB Size	RB Offset	UL Channel	UL Frequency (MHz)	Single Carrier Tx Power (dBm)	Tx Power with DL-CA Active (dBm)
7	20	QPSK	1	0	20850	2510	7	20	QPSK	1	99	21048	2529.8	16.23	13.49
			1	99						16.17	16.02				
7	20	QPSK	1	0	21001	2525.1	7	20	QPSK	1	99	21199	2544.9	16.54	13.52
			1	99						16.38	16.19				
7	20	QPSK	1	0	21152	2540.2	7	20	QPSK	1	99	21350	2560	16.47	13.48
			1	99						16.27	16.07				
38	20	QPSK	1	0	37850	2580	38	20	QPSK	1	99	38048	2599.8	18.11	13.51
			1	99						17.93	17.91				
38	20	QPSK	1	0	37901	2585.1	38	20	QPSK	1	99	38099	2604.9	17.91	13.39
			1	99						17.73	17.67				
38	20	QPSK	1	0	37952	2590.2	38	20	QPSK	1	99	38150	2610	17.93	13.44
			1	99						17.68	17.67				

## <WWNA (Main) Ant-0\_Hotspot On (Power Table-7)>

PCC							SCC							Power	
Band	BW (MHz)	Modulation	RB Size	RB Offset	UL Channel	UL Frequency (MHz)	Band	BW (MHz)	Modulation	RB Size	RB Offset	UL Channel	UL Frequency (MHz)	Single Carrier Tx Power (dBm)	Tx Power with DL-CA Active (dBm)
7	20	QPSK	1	0	20850	2510	7	20	QPSK	1	99	21048	2529.8	20.74	14.06
			1	99						20.58	20.52				
7	20	QPSK	1	0	21001	2525.1	7	20	QPSK	1	99	21199	2544.9	20.77	14.08
			1	99						20.61	20.60				
7	20	QPSK	1	0	21152	2540.2	7	20	QPSK	1	99	21350	2560	20.73	14.06
			1	99						20.57	20.55				

**<WWNA (Main) Ant-0 Extremity Standalone (Power Table-5) / Extremity WLAN On (Power Table-6)>**

PCC							SCC							Power	
Band	BW (MHz)	Modulation	RB Size	RB Offset	UL Channel	UL Frequency (MHz)	Band	BW (MHz)	Modulation	RB Size	RB Offset	UL Channel	UL Frequency (MHz)	Single Carrier Tx Power (dBm)	Tx Power with DL-CA Active (dBm)
7	20	QPSK	1	0	20850	2510	7	20	QPSK	1	99	21048	2529.8	20.95	14.12
			1	99						1	0			20.81	20.80
7	20	QPSK	1	0	21001	2525.1	7	20	QPSK	1	99	21199	2544.9	20.98	13.97
			1	99						1	0			20.87	20.84
7	20	QPSK	1	0	21152	2540.2	7	20	QPSK	1	99	21350	2560	20.89	13.96
			1	99						1	0			20.74	20.73

**SAR Measurements for Intra-Band Contiguous CA**

The SAR testing was performed with the single carrier (uplink CA is inactive) for all test positions for each exposure condition. The LTE uplink CA active was verified with maximum output power on the highest SAR configuration of single carrier for each exposure condition. For intra-band contiguous CA, the SCC channel was set to closest available contiguous channel.

**<KDB 248227 D01, SAR Guidance for Wi-Fi Transmitters>**

- (1) For handsets operating next to ear, hotspot mode or mini-tablet configurations, the initial test position procedures were applied. The test position with the highest extrapolated peak SAR will be used as the initial test position. When the reported SAR of initial test position is  $\leq 0.4$  W/kg, SAR testing for remaining test positions is not required. Otherwise, SAR is evaluated at the subsequent highest peak SAR positions until the reported SAR result is  $\leq 0.8$  W/kg or all test positions are measured.
- (2) For WLAN 2.4 GHz, the highest measured maximum output power channel for DSSS was selected for SAR measurement. When the reported SAR is  $\leq 0.8$  W/kg, no further SAR testing is required. Otherwise, SAR is evaluated at the next highest measured output power channel. When any reported SAR is  $> 1.2$  W/kg, SAR is required for the third channel. For OFDM modes (802.11g/n), SAR is not required when the highest reported SAR for DSSS is adjusted by the ratio of OFDM to DSSS specified maximum output power and it is  $\leq 1.2$  W/kg.
- (3) For WLAN 5GHz, the initial test configuration was selected according to the transmission mode with the highest maximum output power. When the reported SAR of initial test configuration is  $> 0.8$  W/kg, SAR is required for the subsequent highest measured output power channel until the reported SAR result is  $\leq 1.2$  W/kg or all required channels are measured. For other transmission modes, SAR is not required when the highest reported SAR for initial test configuration is adjusted by the ratio of subsequent test configuration to initial test configuration specified maximum output power and it is  $\leq 1.2$  W/kg.
- (4) For WLAN MIMO mode, the power-based standalone SAR test exclusion or the sum of SAR provision in KDB 447498 to determine simultaneous transmission SAR test exclusion should be applied. Otherwise, SAR for MIMO mode will be measured with all applicable antennas transmitting simultaneously at the specified maximum output power of MIMO operation.

# FCC SAR Test Report

## 4.7.2 SAR Results for Head Exposure Condition

Plot No.	Band	Mode	Test Position	Ch.	Tx Antenna	Power Table	Max. Tune-up Power (dBm)	Measured Conducted Power (dBm)	Scaling Factor	Power Drift (dB)	Measured SAR-1g (W/kg)	Scaled SAR-1g (W/kg)
	GSM850	GPRS12	Right Cheek	189	Ant 0	Full	27.5	26.33	1.31	0.01	0.073	0.10
	GSM850	GPRS12	Right Tilted	189	Ant 0	Full	27.5	26.33	1.31	0.03	0.038	0.05
	GSM850	GPRS12	Left Cheek	189	Ant 0	Full	27.5	26.33	1.31	0.05	0.055	0.07
	GSM850	GPRS12	Left Tilted	189	Ant 0	Full	27.5	26.33	1.31	0.12	0.044	0.06
	GSM850	GPRS12	Right Cheek	189	Ant 1	Full	27.5	26.33	1.31	-0.01	0.466	0.61
	GSM850	GPRS12	Right Tilted	189	Ant 1	Full	27.5	26.33	1.31	0.03	0.451	0.59
01	GSM850	GPRS12	Left Cheek	189	Ant 1	Full	27.5	26.33	1.31	0.01	0.524	0.69
	GSM850	GPRS12	Left Tilted	189	Ant 1	Full	27.5	26.33	1.31	0.05	0.512	0.67
	GSM850	GPRS12	Left Cheek	128	Ant 1	Full	27.5	26.22	1.34	0.12	0.468	0.63
	GSM850	GPRS12	Left Cheek	251	Ant 1	Full	27.5	26.31	1.32	0.09	0.438	0.58
	GSM1900	GPRS12	Right Cheek	661	Ant 0	Full	24.5	22.95	1.43	0.02	0.035	0.05
	GSM1900	GPRS12	Right Tilted	661	Ant 0	Full	24.5	22.95	1.43	-0.15	0.032	0.05
	GSM1900	GPRS12	Left Cheek	661	Ant 0	Full	24.5	22.95	1.43	0.13	0.05	0.07
	GSM1900	GPRS12	Left Tilted	661	Ant 0	Full	24.5	22.95	1.43	-0.18	0.039	0.06
	GSM1900	GPRS12	Right Cheek	661	Ant 1	1&2	24.0	22.79	1.32	-0.01	0.557	0.74
	GSM1900	GPRS12	Right Tilted	661	Ant 1	1&2	24.0	22.79	1.32	-0.07	0.618	0.82
	GSM1900	GPRS12	Left Cheek	661	Ant 1	1&2	24.0	22.79	1.32	0.04	0.198	0.26
	GSM1900	GPRS12	Left Tilted	661	Ant 1	1&2	24.0	22.79	1.32	0.01	0.195	0.26
	GSM1900	GPRS12	Right Tilted	512	Ant 1	1&2	24.0	22.39	1.45	-0.09	0.635	0.92
02	GSM1900	GPRS12	Right Tilted	810	Ant 1	1&2	24.0	22.56	1.39	0.12	0.672	0.93
	WCDMA II	RMC12.2K	Right Cheek	9400	Ant 0	Full	24.5	23.00	1.41	0.02	0.071	0.10
	WCDMA II	RMC12.2K	Right Tilted	9400	Ant 0	Full	24.5	23.00	1.41	0.08	0.065	0.09
	WCDMA II	RMC12.2K	Left Cheek	9400	Ant 0	Full	24.5	23.00	1.41	0.10	0.101	0.14
	WCDMA II	RMC12.2K	Left Tilted	9400	Ant 0	Full	24.5	23.00	1.41	-0.15	0.078	0.11
	WCDMA II	RMC12.2K	Right Cheek	9400	Ant 1	1&2	21.0	19.87	1.30	0.03	0.796	1.03
03	WCDMA II	RMC12.2K	Right Tilted	9400	Ant 1	1&2	21.0	19.87	1.30	-0.01	0.913	1.19
	WCDMA II	RMC12.2K	Left Cheek	9400	Ant 1	1&2	21.0	19.87	1.30	0.12	0.315	0.41
	WCDMA II	RMC12.2K	Left Tilted	9400	Ant 1	1&2	21.0	19.87	1.30	0.11	0.288	0.37
	WCDMA II	RMC12.2K	Right Cheek	9262	Ant 1	1&2	21.0	19.67	1.36	0.03	0.777	1.06
	WCDMA II	RMC12.2K	Right Cheek	9538	Ant 1	1&2	21.0	19.71	1.35	-0.13	0.771	1.04
	WCDMA II	RMC12.2K	Right Tilted	9262	Ant 1	1&2	21.0	19.67	1.36	0.10	0.843	1.15
	WCDMA II	RMC12.2K	Right Tilted	9538	Ant 1	1&2	21.0	19.71	1.35	-0.06	0.856	1.16
	WCDMA II	RMC12.2K	Right Tilted	9400	Ant 1	1&2	21.0	19.87	1.30	-0.01	0.905	1.18
	WCDMA IV	RMC12.2K	Right Cheek	1513	Ant 0	Full	23.5	22.10	1.38	0.02	0.043	0.06
	WCDMA IV	RMC12.2K	Right Tilted	1513	Ant 0	Full	23.5	22.10	1.38	0.13	0.038	0.05
	WCDMA IV	RMC12.2K	Left Cheek	1513	Ant 0	Full	23.5	22.10	1.38	-0.15	0.077	0.11
	WCDMA IV	RMC12.2K	Left Tilted	1513	Ant 0	Full	23.5	22.10	1.38	0.08	0.051	0.07
	WCDMA IV	RMC12.2K	Right Cheek	1513	Ant 1	1&2	22.0	20.92	1.28	0.12	0.732	0.94
04	WCDMA IV	RMC12.2K	Right Tilted	1513	Ant 1	1&2	22.0	20.92	1.28	-0.07	0.892	1.14
	WCDMA IV	RMC12.2K	Left Cheek	1513	Ant 1	1&2	22.0	20.92	1.28	-0.03	0.246	0.31
	WCDMA IV	RMC12.2K	Left Tilted	1513	Ant 1	1&2	22.0	20.92	1.28	0.15	0.291	0.37
	WCDMA IV	RMC12.2K	Right Cheek	1312	Ant 1	1&2	22.0	20.79	1.32	0.01	0.773	1.02
	WCDMA IV	RMC12.2K	Right Cheek	1413	Ant 1	1&2	22.0	20.81	1.32	-0.11	0.829	1.09
	WCDMA IV	RMC12.2K	Right Tilted	1312	Ant 1	1&2	22.0	20.79	1.32	0.02	0.853	1.13
	WCDMA IV	RMC12.2K	Right Tilted	1413	Ant 1	1&2	22.0	20.81	1.32	0.08	0.832	1.10
	WCDMA IV	RMC12.2K	Right Tilted	1513	Ant 1	1&2	22.0	20.92	1.28	-0.07	0.882	1.13

# FCC SAR Test Report

Plot No.	Band	Mode	Test Position	Ch.	Tx Antenna	Power Table	Max. Tune-up Power (dBm)	Measured Conducted Power (dBm)	Scaling Factor	Power Drift (dB)	Measured SAR-1g (W/kg)	Scaled SAR-1g (W/kg)
	WCDMA V	RMC12.2K	Right Cheek	4233	Ant 0	Full	24.5	23.81	1.17	-0.15	0.126	0.15
	WCDMA V	RMC12.2K	Right Tilted	4233	Ant 0	Full	24.5	23.81	1.17	0.07	0.065	0.08
	WCDMA V	RMC12.2K	Left Cheek	4233	Ant 0	Full	24.5	23.81	1.17	0.10	0.101	0.12
	WCDMA V	RMC12.2K	Left Tilted	4233	Ant 0	Full	24.5	23.81	1.17	0.01	0.082	0.10
	WCDMA V	RMC12.2K	Right Cheek	4233	Ant 1	Full	24.5	23.81	1.17	-0.02	0.696	0.81
	WCDMA V	RMC12.2K	Right Tilted	4233	Ant 1	Full	24.5	23.81	1.17	-0.06	0.685	0.80
	WCDMA V	RMC12.2K	Left Cheek	4233	Ant 1	Full	24.5	23.81	1.17	0.02	0.713	0.83
	WCDMA V	RMC12.2K	Left Tilted	4233	Ant 1	Full	24.5	23.81	1.17	-0.02	0.708	0.83
	WCDMA V	RMC12.2K	Right Cheek	4132	Ant 1	Full	24.5	23.67	1.21	-0.05	0.671	0.81
	WCDMA V	RMC12.2K	Right Cheek	4182	Ant 1	Full	24.5	23.79	1.18	0.13	0.668	0.79
	WCDMA V	RMC12.2K	Right Tilted	4132	Ant 1	Full	24.5	23.67	1.21	0.08	0.653	0.79
	WCDMA V	RMC12.2K	Right Tilted	4182	Ant 1	Full	24.5	23.79	1.18	-0.01	0.623	0.74
05	WCDMA V	RMC12.2K	Left Cheek	4132	Ant 1	Full	24.5	23.67	1.21	-0.07	0.730	0.88
	WCDMA V	RMC12.2K	Left Cheek	4182	Ant 1	Full	24.5	23.79	1.18	0.02	0.675	0.80
	WCDMA V	RMC12.2K	Left Tilted	4132	Ant 1	Full	24.5	23.67	1.21	-0.05	0.713	0.86
	WCDMA V	RMC12.2K	Left Tilted	4182	Ant 1	Full	24.5	23.79	1.18	0.03	0.670	0.79

Plot No.	Band	Mode	Test Position	Ch.	RB#	RB Offset	Tx Antenna	Power Table	Max. Tune-up Power (dBm)	Measured Conducted Power (dBm)	Scaling Factor	Power Drift (dB)	Measured SAR-1g (W/kg)	Scaled SAR-1g (W/kg)
	LTE 2	QPSK20M	Right Cheek	18700	1	0	Ant 0	Full	23.5	22.14	1.37	0.08	0.059	0.08
	LTE 2	QPSK20M	Right Tilted	18700	1	0	Ant 0	Full	23.5	22.14	1.37	-0.02	0.051	0.07
	LTE 2	QPSK20M	Left Cheek	18700	1	0	Ant 0	Full	23.5	22.14	1.37	0.16	0.085	0.12
	LTE 2	QPSK20M	Left Tilted	18700	1	0	Ant 0	Full	23.5	22.14	1.37	0.01	0.039	0.05
	LTE 2	QPSK20M	Right Cheek	18700	50	25	Ant 0	Full	22.5	21.15	1.36	0.15	0.047	0.06
	LTE 2	QPSK20M	Right Tilted	18700	50	25	Ant 0	Full	22.5	21.15	1.36	0.16	0.041	0.06
	LTE 2	QPSK20M	Left Cheek	18700	50	25	Ant 0	Full	22.5	21.15	1.36	-0.05	0.062	0.08
	LTE 2	QPSK20M	Left Tilted	18700	50	25	Ant 0	Full	22.5	21.15	1.36	0.00	<0.001	0.00
	LTE 2	QPSK20M	Right Cheek	18700	1	0	Ant 1	1&2	20.0	18.93	1.28	0.02	0.551	0.71
06	LTE 2	QPSK20M	Right Tilted	18700	1	0	Ant 1	1&2	20.0	18.93	1.28	0.01	0.679	0.87
	LTE 2	QPSK20M	Left Cheek	18700	1	0	Ant 1	1&2	20.0	18.93	1.28	-0.07	0.262	0.34
	LTE 2	QPSK20M	Left Tilted	18700	1	0	Ant 1	1&2	20.0	18.93	1.28	0.17	0.265	0.34
	LTE 2	QPSK20M	Right Cheek	18700	50	25	Ant 1	1&2	20.0	18.91	1.29	0.13	0.533	0.69
	LTE 2	QPSK20M	Right Tilted	18700	50	25	Ant 1	1&2	20.0	18.91	1.29	-0.03	0.662	0.85
	LTE 2	QPSK20M	Left Cheek	18700	50	25	Ant 1	1&2	20.0	18.91	1.29	0.12	0.255	0.33
	LTE 2	QPSK20M	Left Tilted	18700	50	25	Ant 1	1&2	20.0	18.91	1.29	-0.03	0.258	0.33
	LTE 2	QPSK20M	Right Tilted	18900	1	0	Ant 1	1&2	20.0	18.87	1.30	0.05	0.657	0.85
	LTE 2	QPSK20M	Right Tilted	19100	1	0	Ant 1	1&2	20.0	18.82	1.31	0.01	0.656	0.86
	LTE 2	QPSK20M	Right Tilted	18900	50	25	Ant 1	1&2	20.0	18.85	1.30	0.13	0.665	0.86
	LTE 2	QPSK20M	Right Tilted	19100	50	25	Ant 1	1&2	20.0	18.81	1.32	-0.12	0.633	0.84
	LTE 2	QPSK20M	Right Tilted	18700	100	0	Ant 1	1&2	20.0	18.87	1.30	0.18	0.612	0.80

Note: The "< 0.001" means there is no SAR value or the SAR is too low to be measured.

# FCC SAR Test Report

Plot No.	Band	Mode	Test Position	Ch.	RB#	RB Offset	Tx Antenna	Power Table	Max. Tune-up Power (dBm)	Measured Conducted Power (dBm)	Scaling Factor	Power Drift (dB)	Measured SAR-1g (W/kg)	Scaled SAR-1g (W/kg)
	LTE 4	QPSK20M	Right Cheek	20050	1	0	Ant 0	Full	23.5	22.01	1.41	0.02	0.047	0.07
	LTE 4	QPSK20M	Right Tilted	20050	1	0	Ant 0	Full	23.5	22.01	1.41	-0.08	0.043	0.06
	LTE 4	QPSK20M	Left Cheek	20050	1	0	Ant 0	Full	23.5	22.01	1.41	0.12	0.08	0.11
	LTE 4	QPSK20M	Left Tilted	20050	1	0	Ant 0	Full	23.5	22.01	1.41	0.15	0.046	0.06
	LTE 4	QPSK20M	Right Cheek	20050	50	50	Ant 0	Full	22.5	20.87	1.46	-0.11	0.039	0.06
	LTE 4	QPSK20M	Right Tilted	20050	50	50	Ant 0	Full	22.5	20.87	1.46	0.18	0.031	0.05
	LTE 4	QPSK20M	Left Cheek	20050	50	50	Ant 0	Full	22.5	20.87	1.46	0.03	0.068	0.10
	LTE 4	QPSK20M	Left Tilted	20050	50	50	Ant 0	Full	22.5	20.87	1.46	0.05	0.032	0.05
	LTE 4	QPSK20M	Right Cheek	20050	1	0	Ant 1	1&2	22.0	20.73	1.34	0.16	0.531	0.71
	LTE 4	QPSK20M	Right Tilted	20050	1	0	Ant 1	1&2	22.0	20.73	1.34	0.17	0.681	0.91
	LTE 4	QPSK20M	Left Cheek	20050	1	0	Ant 1	1&2	22.0	20.73	1.34	-0.12	0.233	0.31
	LTE 4	QPSK20M	Left Tilted	20050	1	0	Ant 1	1&2	22.0	20.73	1.34	0.05	0.261	0.35
	LTE 4	QPSK20M	Right Cheek	20050	50	50	Ant 1	1&2	22.0	20.70	1.35	0.11	0.519	0.70
	LTE 4	QPSK20M	Right Tilted	20050	50	50	Ant 1	1&2	22.0	20.70	1.35	-0.05	0.669	0.90
	LTE 4	QPSK20M	Left Cheek	20050	50	50	Ant 1	1&2	22.0	20.70	1.35	-0.19	0.226	0.31
	LTE 4	QPSK20M	Left Tilted	20050	50	50	Ant 1	1&2	22.0	20.70	1.35	0.18	0.247	0.33
	LTE 4	QPSK20M	Right Tilted	20175	1	0	Ant 1	1&2	22.0	20.71	1.35	0.09	0.668	0.90
07	LTE 4	QPSK20M	Right Tilted	20300	1	0	Ant 1	1&2	22.0	20.69	1.35	0.03	0.705	0.95
	LTE 4	QPSK20M	Right Tilted	20175	50	50	Ant 1	1&2	22.0	20.68	1.36	0.07	0.662	0.90
	LTE 4	QPSK20M	Right Tilted	20300	50	50	Ant 1	1&2	22.0	20.65	1.36	0.11	0.692	0.94
	LTE 4	QPSK20M	Right Tilted	20050	100	0	Ant 1	1&2	22.0	20.68	1.36	-0.02	0.671	0.91
	LTE 5	QPSK10M	Right Cheek	20525	1	0	Ant 0	Full	23.5	22.30	1.32	0.13	0.063	0.08
	LTE 5	QPSK10M	Right Tilted	20525	1	0	Ant 0	Full	23.5	22.30	1.32	0.00	<0.001	0.00
	LTE 5	QPSK10M	Left Cheek	20525	1	0	Ant 0	Full	23.5	22.30	1.32	-0.03	0.051	0.07
	LTE 5	QPSK10M	Left Tilted	20525	1	0	Ant 0	Full	23.5	22.30	1.32	0.00	<0.001	0.00
	LTE 5	QPSK10M	Right Cheek	20525	25	0	Ant 0	Full	22.5	21.39	1.29	-0.01	0.055	0.07
	LTE 5	QPSK10M	Right Tilted	20525	25	0	Ant 0	Full	22.5	21.39	1.29	0.00	<0.001	0.00
	LTE 5	QPSK10M	Left Cheek	20525	25	0	Ant 0	Full	22.5	21.39	1.29	0.06	0.038	0.05
	LTE 5	QPSK10M	Left Tilted	20525	25	0	Ant 0	Full	22.5	21.39	1.29	0.00	<0.001	0.00
	LTE 5	QPSK10M	Right Cheek	20525	1	0	Ant 1	Full	23.5	22.30	1.32	-0.08	0.608	0.80
	LTE 5	QPSK10M	Right Tilted	20525	1	0	Ant 1	Full	23.5	22.30	1.32	-0.17	0.542	0.72
	LTE 5	QPSK10M	Left Cheek	20525	1	0	Ant 1	Full	23.5	22.30	1.32	-0.04	0.532	0.70
	LTE 5	QPSK10M	Left Tilted	20525	1	0	Ant 1	Full	23.5	22.30	1.32	-0.07	0.448	0.59
	LTE 5	QPSK10M	Right Cheek	20525	25	0	Ant 1	Full	22.5	21.39	1.29	0.13	0.506	0.65
	LTE 5	QPSK10M	Right Tilted	20525	25	0	Ant 1	Full	22.5	21.39	1.29	-0.03	0.451	0.58
	LTE 5	QPSK10M	Left Cheek	20525	25	0	Ant 1	Full	22.5	21.39	1.29	0.11	0.413	0.53
	LTE 5	QPSK10M	Left Tilted	20525	25	0	Ant 1	Full	22.5	21.39	1.29	0.09	0.384	0.50
08	LTE 5	QPSK10M	Right Cheek	20450	1	0	Ant 1	Full	23.5	22.25	1.33	-0.08	0.618	0.82
	LTE 5	QPSK10M	Right Cheek	20600	1	0	Ant 1	Full	23.5	22.24	1.34	-0.03	0.562	0.75
	LTE 5	QPSK10M	Right Cheek	20525	50	0	Ant 1	Full	22.5	21.36	1.30	0.05	0.431	0.56

Note: The "< 0.001" means there is no SAR value or the SAR is too low to be measured.



# FCC SAR Test Report

Plot No.	Uplink Mode	Band	Mode	Test Position	Ch.	RB#	RB Offset	Tx Antenna	Power Table	Max. Tune-up Power (dBm)	Measured Conducted Power (dBm)	Scaling Factor	Power Drift (dB)	Measured SAR-1g (W/kg)	Scaled SAR-1g (W/kg)
	Single Carrier (CA inactive)	LTE 7	QPSK20M	Right Cheek	21100	1	50	Ant 0	Full	23.5	22.41	1.29	0.11	0.068	0.09
		LTE 7	QPSK20M	Right Tilted	21100	1	50	Ant 0	Full	23.5	22.41	1.29	0.15	0.079	0.10
		LTE 7	QPSK20M	Left Cheek	21100	1	50	Ant 0	Full	23.5	22.41	1.29	-0.01	0.082	0.11
		LTE 7	QPSK20M	Left Tilted	21100	1	50	Ant 0	Full	23.5	22.41	1.29	-0.07	0.055	0.07
		LTE 7	QPSK20M	Right Cheek	21100	50	50	Ant 0	Full	22.5	21.37	1.30	0.12	0.057	0.07
		LTE 7	QPSK20M	Right Tilted	21100	50	50	Ant 0	Full	22.5	21.37	1.30	0.06	0.065	0.08
		LTE 7	QPSK20M	Left Cheek	21100	50	50	Ant 0	Full	22.5	21.37	1.30	0.05	0.066	0.09
		LTE 7	QPSK20M	Left Tilted	21100	50	50	Ant 0	Full	22.5	21.37	1.30	0.00	<0.001	0.00
		LTE 7	QPSK20M	Right Cheek	21100	1	50	Ant 1	1&2	17.5	16.62	1.22	-0.03	0.696	0.85
		LTE 7	QPSK20M	Right Tilted	21100	1	50	Ant 1	1&2	17.5	16.62	1.22	-0.15	0.577	0.70
		LTE 7	QPSK20M	Left Cheek	21100	1	50	Ant 1	1&2	17.5	16.62	1.22	0.11	0.253	0.31
		LTE 7	QPSK20M	Left Tilted	21100	1	50	Ant 1	1&2	17.5	16.62	1.22	0.18	0.211	0.26
		LTE 7	QPSK20M	Right Cheek	21100	50	50	Ant 1	1&2	17.5	16.52	1.25	-0.03	0.691	0.86
		LTE 7	QPSK20M	Right Tilted	21100	50	50	Ant 1	1&2	17.5	16.52	1.25	0.05	0.554	0.69
		LTE 7	QPSK20M	Left Cheek	21100	50	50	Ant 1	1&2	17.5	16.52	1.25	0.12	0.251	0.31
		LTE 7	QPSK20M	Left Tilted	21100	50	50	Ant 1	1&2	17.5	16.52	1.25	0.12	0.201	0.25
		LTE 7	QPSK20M	Right Cheek	20850	1	50	Ant 1	1&2	17.5	16.30	1.32	0.12	0.665	0.88
09		LTE 7	QPSK20M	Right Cheek	21350	1	50	Ant 1	1&2	17.5	16.40	1.27	-0.03	0.785	1.01
		LTE 7	QPSK20M	Right Cheek	20850	50	50	Ant 1	1&2	17.5	16.31	1.32	0.12	0.658	0.87
		LTE 7	QPSK20M	Right Cheek	21350	50	50	Ant 1	1&2	17.5	16.41	1.29	-0.03	0.767	0.99
	LTE 7	QPSK20M	Right Cheek	21100	100	0	Ant 1	1&2	17.5	16.33	1.31	-0.03	0.761	1.00	
	2 CC (CA active)	LTE 7	QPSK20M	Right Cheek	PCC:21001 SCC:21199	PCC:1 SCC:1	PCC:99 SCC:0	Ant 1	1&2	17.5	16.19	1.35	0.12	0.596	0.80
		LTE 7	QPSK20M	Right Cheek	PCC:20850 SCC:21048	PCC:1 SCC:1	PCC:99 SCC:0	Ant 1	1&2	17.5	16.02	1.41	0.08	0.563	0.79
		LTE 7	QPSK20M	Right Cheek	PCC:21152 SCC:21350	PCC:1 SCC:1	PCC:99 SCC:0	Ant 1	1&2	17.5	16.07	1.39	-0.01	0.647	0.90

Note: The "< 0.001" means there is no SAR value or the SAR is too low to be measured.



# FCC SAR Test Report

Plot No.	Uplink Mode	Band	Mode	Test Position	Ch.	RB#	RB Offset	Tx Antenna	Power Table	Max. Tune-up Power (dBm)	Measured Conducted Power (dBm)	Scaling Factor	Power Drift (dB)	Measured SAR-1g (W/kg)	Scaled SAR-1g (W/kg)
	Single Carrier (CA inactive)	LTE 38	QPSK20M	Right Cheek	37850	1	0	Ant 0	Full	23.5	22.62	1.22	-0.18	0.037	0.05
		LTE 38	QPSK20M	Right Tilted	37850	1	0	Ant 0	Full	23.5	22.62	1.22	0.02	0.035	0.04
		LTE 38	QPSK20M	Left Cheek	37850	1	0	Ant 0	Full	23.5	22.62	1.22	-0.01	0.031	0.04
		LTE 38	QPSK20M	Left Tilted	37850	1	0	Ant 0	Full	23.5	22.62	1.22	0.00	0.024	0.03
		LTE 38	QPSK20M	Right Cheek	37850	50	25	Ant 0	Full	22.5	21.54	1.25	0.00	0.025	0.03
		LTE 38	QPSK20M	Right Tilted	37850	50	25	Ant 0	Full	22.5	21.54	1.25	0.00	0.029	0.04
		LTE 38	QPSK20M	Left Cheek	37850	50	25	Ant 0	Full	22.5	21.54	1.25	0.00	0.029	0.04
		LTE 38	QPSK20M	Left Tilted	37850	50	25	Ant 0	Full	22.5	21.54	1.25	0.00	<0.001	0.00
		LTE 38	QPSK20M	Right Cheek	37850	1	0	Ant 1	1&2	19.5	18.11	1.38	0.02	0.712	0.98
		LTE 38	QPSK20M	Right Tilted	37850	1	0	Ant 1	1&2	19.5	18.11	1.38	-0.18	0.688	0.95
		LTE 38	QPSK20M	Left Cheek	37850	1	0	Ant 1	1&2	19.5	18.11	1.38	-0.11	0.356	0.49
		LTE 38	QPSK20M	Left Tilted	37850	1	0	Ant 1	1&2	19.5	18.11	1.38	0.05	0.303	0.42
		LTE 38	QPSK20M	Right Cheek	37850	50	25	Ant 1	1&2	19.5	18.08	1.39	0.13	0.698	0.97
		LTE 38	QPSK20M	Right Tilted	37850	50	25	Ant 1	1&2	19.5	18.08	1.39	0.18	0.685	0.95
		LTE 38	QPSK20M	Left Cheek	37850	50	25	Ant 1	1&2	19.5	18.08	1.39	-0.01	0.353	0.49
		LTE 38	QPSK20M	Left Tilted	37850	50	25	Ant 1	1&2	19.5	18.08	1.39	0.02	0.289	0.40
10		LTE 38	QPSK20M	Right Cheek	38000	1	0	Ant 1	1&2	19.5	17.91	1.44	-0.13	0.741	1.07
		LTE 38	QPSK20M	Right Cheek	38150	1	0	Ant 1	1&2	19.5	17.93	1.44	-0.08	0.824	1.19
		LTE 38	QPSK20M	Right Cheek	38000	50	25	Ant 1	1&2	19.5	17.88	1.45	-0.18	0.715	1.04
		LTE 38	QPSK20M	Right Cheek	38150	50	25	Ant 1	1&2	19.5	17.83	1.47	-0.18	0.743	1.09
	LTE 38	QPSK20M	Right Cheek	37850	100	0	Ant 1	1&2	19.5	18.07	1.39	-0.18	0.703	0.98	
	LTE 38	QPSK20M	Right Tilted	38000	1	0	Ant 1	1&2	19.5	17.91	1.44	-0.18	0.712	1.03	
	LTE 38	QPSK20M	Right Tilted	38150	1	0	Ant 1	1&2	19.5	17.93	1.44	-0.18	0.756	1.09	
	LTE 38	QPSK20M	Right Tilted	38000	50	25	Ant 1	1&2	19.5	17.88	1.45	-0.18	0.708	1.03	
	LTE 38	QPSK20M	Right Tilted	38150	50	25	Ant 1	1&2	19.5	17.83	1.47	-0.18	0.701	1.03	
	LTE 38	QPSK20M	Right Tilted	37850	100	0	Ant 1	1&2	19.5	18.07	1.39	-0.18	0.652	0.91	
	LTE 38	QPSK20M	Right Cheek	38150	1	0	Ant 1	1&2	19.5	17.93	1.44	-0.08	0.815	1.17	
	2 CC (CA active)	LTE 38	QPSK20M	Right Cheek	PCC:37850 SCC:38048	PCC:1 SCC:1	PCC:99 SCC:0	Ant 1	1&2	19.5	17.91	1.44	-0.11	0.632	0.91
		LTE 38	QPSK20M	Right Cheek	PCC:37901 SCC:38099	PCC:1 SCC:1	PCC:99 SCC:0	Ant 1	1&2	19.5	17.67	1.52	0.08	0.643	0.98
		LTE 38	QPSK20M	Right Cheek	PCC:37952 SCC:38150	PCC:1 SCC:1	PCC:99 SCC:0	Ant 1	1&2	19.5	17.67	1.52	0.02	0.744	1.13

**Note:** The "< 0.001" means there is no SAR value or the SAR is too low to be measured.

# FCC SAR Test Report

Plot No.	Band	Mode	Test Position	Ch.	Power Table	Duty Cycle	Crest Factor	Max. Tune-up Power (dBm)	Measured Conducted Power (dBm)	Scaling Factor	Power Drift (dB)	Measured SAR-1g (W/kg)	Scaled SAR-1g (W/kg)
	WLAN2.4G	802.11b	Right Cheek	11	1	100.00	1.00	16.5	16.09	1.10	0.02	0.071	0.08
	WLAN2.4G	802.11b	Right Tilted	11	1	100.00	1.00	16.5	16.09	1.10	-0.11	0.065	0.07
11	WLAN2.4G	802.11b	Left Cheek	11	1	100.00	1.00	16.5	16.09	1.10	0.18	1.08	1.19
	WLAN2.4G	802.11b	Left Tilted	11	1	100.00	1.00	16.5	16.09	1.10	0.15	0.427	0.47
	WLAN2.4G	802.11b	Left Cheek	1	1	100.00	1.00	16.5	15.57	1.24	0.01	0.869	1.08
	WLAN2.4G	802.11b	Left Cheek	6	1	100.00	1.00	16.5	15.51	1.26	0.07	0.938	1.18
	WLAN2.4G	802.11b	Left Cheek	11	1	100.00	1.00	16.5	16.09	1.10	0.05	1.05	1.16
	WLAN2.4G	802.11b	Right Cheek	11	2	100.00	1.00	15.0	14.76	1.06	-0.08	0.042	0.04
	WLAN2.4G	802.11b	Right Tilted	11	2	100.00	1.00	15.0	14.76	1.06	0.16	0.038	0.04
12	WLAN2.4G	802.11b	Left Cheek	11	2	100.00	1.00	15.0	14.76	1.06	0	0.636	0.67
	WLAN2.4G	802.11b	Left Tilted	11	2	100.00	1.00	15.0	14.76	1.06	-0.16	0.249	0.26
	WLAN2.4G	802.11b	Left Cheek	1	2	100.00	1.00	15.0	14.21	1.20	-0.19	0.507	0.61
	WLAN2.4G	802.11b	Left Cheek	6	2	100.00	1.00	15.0	14.26	1.19	-0.13	0.552	0.66
	WLAN5.3G	802.11n HT40	Right Cheek	62	1&2	98.40	1.02	12.5	11.92	1.14	0.02	0.031	0.04
	WLAN5.3G	802.11n HT40	Right Tilted	62	1&2	98.40	1.02	12.5	11.92	1.14	0.05	0.029	0.03
13	WLAN5.3G	802.11n HT40	Left Cheek	62	1&2	98.40	1.02	12.5	11.92	1.14	-0.11	0.092	0.11
	WLAN5.3G	802.11n HT40	Left Tilted	62	1&2	98.40	1.02	12.5	11.92	1.14	0.15	0.059	0.07
	WLAN5.3G	802.11n HT40	Left Cheek	54	1&2	98.40	1.02	12.5	11.75	1.19	0.02	0.083	0.10
	WLAN5.6G	802.11n HT40	Right Cheek	110	1&2	98.40	1.02	12.5	12.49	1.00	0.03	0.066	0.07
	WLAN5.6G	802.11n HT40	Right Tilted	110	1&2	98.40	1.02	12.5	12.49	1.00	0.05	0.055	0.06
14	WLAN5.6G	802.11n HT40	Left Cheek	110	1&2	98.40	1.02	12.5	12.49	1.00	0.1	0.209	0.21
	WLAN5.6G	802.11n HT40	Left Tilted	110	1&2	98.40	1.02	12.5	12.49	1.00	-0.13	0.121	0.12
	WLAN5.6G	802.11n HT40	Left Cheek	102	1&2	98.40	1.02	12.5	12.34	1.04	0.07	0.185	0.20
	WLAN5.6G	802.11n HT40	Left Cheek	118	1&2	98.40	1.02	12.5	12.47	1.01	-0.09	0.188	0.19
	WLAN5.6G	802.11n HT40	Left Cheek	126	1&2	98.40	1.02	12.5	12.27	1.05	-0.12	0.175	0.19
	WLAN5.6G	802.11n HT40	Left Cheek	134	1&2	98.40	1.02	12.5	11.84	1.16	0.09	0.143	0.17
	WLAN5.6G	802.11n HT40	Left Cheek	142	1&2	98.40	1.02	12.5	11.57	1.24	0.17	0.126	0.16
	WLAN5.8G	802.11n HT40	Right Cheek	159	1&2	98.40	1.02	12.5	12.24	1.06	0.01	0.053	0.06
	WLAN5.8G	802.11n HT40	Right Tilted	159	1&2	98.40	1.02	12.5	12.24	1.06	-0.08	0.048	0.05
	WLAN5.8G	802.11n HT40	Left Cheek	159	1&2	98.40	1.02	12.5	12.24	1.06	0.13	0.142	0.15
	WLAN5.8G	802.11n HT40	Left Tilted	159	1&2	98.40	1.02	12.5	12.24	1.06	-0.09	0.088	0.10
15	WLAN5.8G	802.11n HT40	Left Cheek	151	1&2	98.40	1.02	12.5	12.12	1.09	-0.10	0.150	0.17
	BT	BDR	Right Cheek	0	-	100.00	1.00	12.0	10.92	1.28	0.04	0.00801	0.01
	BT	BDR	Right Tilted	0	-	100.00	1.00	12.0	10.92	1.28	0.05	0.00404	0.01
	BT	BDR	Left Cheek	0	-	100.00	1.00	12.0	10.92	1.28	0.12	0.034	0.04
	BT	BDR	Left Tilted	0	-	100.00	1.00	12.0	10.92	1.28	-0.03	0.015	0.02
	BT	BDR	Left Cheek	39	-	100.00	1.00	12.0	10.59	1.38	0.07	0.035	0.05
16	BT	BDR	Left Cheek	78	-	100.00	1.00	12.0	10.61	1.38	0.13	0.049	0.07

# FCC SAR Test Report

## 4.7.3 SAR Results for Body-worn Exposure Condition (Test Separation Distance is 15 mm)

Plot No.	Band	Mode	Test Position	Ch.	Tx Antenna	Power Table	Max. Tune-up Power (dBm)	Measured Conducted Power (dBm)	Scaling Factor	Power Drift (dB)	Measured SAR-1g (W/kg)	Scaled SAR-1g (W/kg)
	GSM850	GPRS12	Front Face	189	Ant 0	Full	27.5	26.33	1.31	-0.05	0.079	0.10
	GSM850	GPRS12	Rear Face	189	Ant 0	Full	27.5	26.33	1.31	0.10	0.084	0.11
	GSM850	GPRS12	Front Face	189	Ant 1	Full	27.5	26.33	1.31	-0.08	0.086	0.11
	GSM850	GPRS12	Rear Face	189	Ant 1	Full	27.5	26.33	1.31	0.13	0.091	0.12
17	GSM850	GPRS12	Rear Face	128	Ant 1	Full	27.5	26.22	1.34	-0.09	0.095	<b>0.13</b>
	GSM850	GPRS12	Rear Face	251	Ant 1	Full	27.5	26.31	1.32	0.07	0.093	0.12
	GSM1900	GPRS12	Front Face	661	Ant 0	Full	24.50	22.95	1.43	0.02	0.205	0.29
	GSM1900	GPRS12	Rear Face	661	Ant 0	Full	24.50	22.95	1.43	-0.11	0.296	0.42
	GSM1900	GPRS12	Front Face	661	Ant 1	Full	24.50	22.95	1.43	0.07	0.078	0.11
	GSM1900	GPRS12	Rear Face	661	Ant 1	Full	24.50	22.95	1.43	-0.07	0.121	0.17
18	GSM1900	GPRS12	Rear Face	512	Ant 0	Full	24.50	22.93	1.44	0.01	0.341	<b>0.49</b>
	GSM1900	GPRS12	Rear Face	810	Ant 0	Full	24.50	22.69	1.52	0.08	0.315	0.48
	WCDMA II	RMC12.2K	Front Face	9400	Ant 0	Full	24.5	23.00	1.41	0.05	0.555	0.78
	WCDMA II	RMC12.2K	Rear Face	9400	Ant 0	Full	24.5	23.00	1.41	-0.12	0.791	1.12
	WCDMA II	RMC12.2K	Front Face	9400	Ant 1	Full	24.5	23.00	1.41	0.17	0.242	0.34
	WCDMA II	RMC12.2K	Rear Face	9400	Ant 1	Full	24.5	23.00	1.41	-0.08	0.326	0.46
19	WCDMA II	RMC12.2K	Rear Face	9262	Ant 0	Full	24.5	22.93	1.44	-0.15	0.802	<b>1.15</b>
	WCDMA II	RMC12.2K	Rear Face	9538	Ant 0	Full	24.5	22.97	1.42	0.08	0.731	1.04
	WCDMA II	RMC12.2K	Rear Face	9262	Ant 0	Full	24.5	22.93	1.44	0.02	0.795	1.14
	WCDMA IV	RMC12.2K	Front Face	1513	Ant 0	Full	23.5	22.10	1.38	0.08	0.329	0.45
	WCDMA IV	RMC12.2K	Rear Face	1513	Ant 0	Full	23.5	22.10	1.38	0.05	0.499	0.69
	WCDMA IV	RMC12.2K	Front Face	1513	Ant 1	Full	23.5	22.10	1.38	0.13	0.113	0.16
	WCDMA IV	RMC12.2K	Rear Face	1513	Ant 1	Full	23.5	22.10	1.38	-0.02	0.165	0.23
20	WCDMA IV	RMC12.2K	Rear Face	1312	Ant 0	Full	23.5	22.04	1.40	-0.12	0.512	<b>0.72</b>
	WCDMA IV	RMC12.2K	Rear Face	1413	Ant 0	Full	23.5	22.05	1.40	0.01	0.505	0.71
	WCDMA V	RMC12.2K	Front Face	4233	Ant 0	Full	24.5	23.81	1.17	0.02	0.105	0.12
21	WCDMA V	RMC12.2K	Rear Face	4233	Ant 0	Full	24.5	23.81	1.17	-0.03	0.126	<b>0.15</b>
	WCDMA V	RMC12.2K	Front Face	4233	Ant 1	Full	24.5	23.81	1.17	0.08	0.115	0.13
	WCDMA V	RMC12.2K	Rear Face	4233	Ant 1	Full	24.5	23.81	1.17	-0.05	0.126	0.15
	WCDMA V	RMC12.2K	Rear Face	4132	Ant 0	Full	24.5	23.67	1.21	-0.15	0.088	0.11
	WCDMA V	RMC12.2K	Rear Face	4182	Ant 0	Full	24.5	23.79	1.18	0.03	0.102	0.12

# FCC SAR Test Report

Plot No.	Band	Mode	Test Position	Ch.	RB#	RB Offset	Tx Antenna	Power Table	Max. Tune-up Power (dBm)	Measured Conducted Power (dBm)	Scaling Factor	Power Drift (dB)	Measured SAR-1g (W/kg)	Scaled SAR-1g (W/kg)
	LTE 2	QPSK20M	Front Face	18700	1	0	Ant 0	Full	23.5	22.14	1.37	0.05	0.492	0.67
	LTE 2	QPSK20M	Rear Face	18700	1	0	Ant 0	Full	23.5	22.14	1.37	-0.13	0.732	1.00
	LTE 2	QPSK20M	Front Face	18700	50	25	Ant 0	Full	22.5	21.15	1.36	0.07	0.412	0.56
	LTE 2	QPSK20M	Rear Face	18700	50	25	Ant 0	Full	22.5	21.15	1.36	0.11	0.583	0.79
	LTE 2	QPSK20M	Front Face	18700	1	0	Ant 1	Full	23.5	22.14	1.37	0.17	0.151	0.21
	LTE 2	QPSK20M	Rear Face	18700	1	0	Ant 1	Full	23.5	22.14	1.37	-0.1	0.233	0.32
	LTE 2	QPSK20M	Front Face	18700	50	25	Ant 1	Full	22.5	21.15	1.36	0.08	0.125	0.17
	LTE 2	QPSK20M	Rear Face	18700	50	25	Ant 1	Full	22.5	21.15	1.36	0.03	0.192	0.26
22	LTE 2	QPSK20M	Rear Face	18900	1	0	Ant 0	Full	23.5	22.00	1.41	-0.03	0.740	1.04
	LTE 2	QPSK20M	Rear Face	19100	1	0	Ant 0	Full	23.5	21.92	1.44	0.18	0.701	1.01
	LTE 2	QPSK20M	Rear Face	18700	100	0	Ant 0	Full	22.5	21.07	1.39	-0.13	0.566	0.79
	LTE 4	QPSK20M	Front Face	20050	1	0	Ant 0	Full	23.5	22.01	1.41	0.11	0.363	0.51
	LTE 4	QPSK20M	Rear Face	20050	1	0	Ant 0	Full	23.5	22.01	1.41	-0.06	0.542	0.76
	LTE 4	QPSK20M	Front Face	20050	50	50	Ant 0	Full	22.5	20.87	1.46	0.08	0.302	0.44
	LTE 4	QPSK20M	Rear Face	20050	50	50	Ant 0	Full	22.5	20.87	1.46	0.13	0.451	0.66
	LTE 4	QPSK20M	Front Face	20050	1	0	Ant 1	Full	23.5	22.01	1.41	0.02	0.072	0.10
	LTE 4	QPSK20M	Rear Face	20050	1	0	Ant 1	Full	23.5	22.01	1.41	-0.09	0.116	0.16
	LTE 4	QPSK20M	Front Face	20050	50	50	Ant 1	Full	22.5	20.87	1.46	-0.13	0.061	0.09
	LTE 4	QPSK20M	Rear Face	20050	50	50	Ant 1	Full	22.5	20.87	1.46	0.15	0.103	0.15
	LTE 4	QPSK20M	Rear Face	20175	1	0	Ant 0	Full	23.5	21.97	1.42	-0.16	0.539	0.77
23	LTE 4	QPSK20M	Rear Face	20300	1	0	Ant 0	Full	23.5	21.98	1.42	-0.06	0.547	0.78
	LTE 5	QPSK10M	Front Face	20525	1	0	Ant 0	Full	23.5	22.30	1.32	-0.07	0.075	0.10
	LTE 5	QPSK10M	Rear Face	20525	1	0	Ant 0	Full	23.5	22.30	1.32	-0.03	0.080	0.11
	LTE 5	QPSK10M	Front Face	20525	25	0	Ant 0	Full	22.5	21.39	1.29	0.03	0.055	0.07
	LTE 5	QPSK10M	Rear Face	20525	25	0	Ant 0	Full	22.5	21.39	1.29	-0.06	0.074	0.10
	LTE 5	QPSK10M	Front Face	20525	1	0	Ant 1	Full	23.5	22.30	1.32	-0.08	0.083	0.11
	LTE 5	QPSK10M	Rear Face	20525	1	0	Ant 1	Full	23.5	22.30	1.32	0.02	0.083	0.11
	LTE 5	QPSK10M	Front Face	20525	25	0	Ant 1	Full	22.5	21.39	1.29	0.07	0.072	0.09
	LTE 5	QPSK10M	Rear Face	20525	25	0	Ant 1	Full	22.5	21.39	1.29	-0.13	0.079	0.10
24	LTE 5	QPSK10M	Rear Face	20450	1	0	Ant 1	Full	23.5	22.25	1.33	-0.12	0.090	0.12
	LTE 5	QPSK10M	Rear Face	20600	1	0	Ant 1	Full	23.5	22.24	1.34	0.05	0.089	0.12

# FCC SAR Test Report

Plot No.	Uplink Mode	Band	Mode	Test Position	Ch.	RB#	RB Offset	Tx Antenna	Power Table	Max. Tune-up Power (dBm)	Measured Conducted Power (dBm)	Scaling Factor	Power Drift (dB)	Measured SAR-1g (W/kg)	Scaled SAR-1g (W/kg)
	Single Carrier (CA inactive)	LTE 7	QPSK20M	Front Face	21100	1	50	Ant 0	Full	23.5	22.41	1.29	0.12	0.506	0.65
		LTE 7	QPSK20M	Rear Face	21100	1	50	Ant 0	Full	23.5	22.41	1.29	0.05	0.629	0.81
		LTE 7	QPSK20M	Front Face	21100	50	50	Ant 0	Full	22.5	21.37	1.30	-0.13	0.409	0.53
		LTE 7	QPSK20M	Rear Face	21100	50	50	Ant 0	Full	22.5	21.37	1.30	0.17	0.513	0.67
		LTE 7	QPSK20M	Front Face	21100	1	50	Ant 1	Full	23.5	22.41	1.29	-0.13	0.324	0.42
		LTE 7	QPSK20M	Rear Face	21100	1	50	Ant 1	Full	23.5	22.41	1.29	-0.15	0.316	0.41
		LTE 7	QPSK20M	Front Face	21100	50	50	Ant 1	Full	22.5	21.37	1.30	-0.07	0.267	0.35
		LTE 7	QPSK20M	Rear Face	21100	50	50	Ant 1	Full	22.5	21.37	1.30	-0.09	0.258	0.34
25		LTE 7	QPSK20M	Rear Face	20850	1	50	Ant 0	Full	23.5	22.29	1.32	-0.07	0.666	0.88
		LTE 7	QPSK20M	Rear Face	21350	1	50	Ant 0	Full	23.5	22.30	1.32	0.11	0.626	0.83
	LTE 7	QPSK20M	Rear Face	21100	100	0	Ant 0	Full	22.5	21.37	1.30	0.05	0.629	0.82	
	2 CC (CA active)	LTE 7	QPSK20M	Rear Face	PCC:21001 SCC:21199	PCC:1 SCC:1	PCC:99 SCC:0	Ant 0	Full	23.5	22.27	1.33	0.10	0.497	0.66

Plot No.	Uplink Mode	Band	Mode	Test Position	Ch.	RB#	RB Offset	Tx Antenna	Power Table	Max. Tune-up Power (dBm)	Measured Conducted Power (dBm)	Scaling Factor	Power Drift (dB)	Measured SAR-1g (W/kg)	Scaled SAR-1g (W/kg)
	Single Carrier (CA inactive)	LTE 38	QPSK20M	Front Face	37850	1	0	Ant 0	Full	23.5	22.62	1.22	0.05	0.281	0.34
26		LTE 38	QPSK20M	Rear Face	37850	1	0	Ant 0	Full	23.5	22.62	1.22	-0.1	0.346	0.42
		LTE 38	QPSK20M	Front Face	37850	50	25	Ant 0	Full	22.5	21.54	1.25	-0.03	0.217	0.27
		LTE 38	QPSK20M	Rear Face	37850	50	25	Ant 0	Full	22.5	21.54	1.25	0.01	0.270	0.34
		LTE 38	QPSK20M	Front Face	37850	1	0	Ant 1	Full	23.5	22.62	1.22	-0.09	0.247	0.30
		LTE 38	QPSK20M	Rear Face	37850	1	0	Ant 1	Full	23.5	22.62	1.22	0.05	0.238	0.29
		LTE 38	QPSK20M	Front Face	37850	50	25	Ant 1	Full	22.5	21.54	1.25	0.12	0.204	0.26
		LTE 38	QPSK20M	Rear Face	37850	50	25	Ant 1	Full	22.5	21.54	1.25	-0.08	0.194	0.24
		LTE 38	QPSK20M	Rear Face	38000	1	0	Ant 0	Full	23.5	22.45	1.27	0.09	0.325	0.41
		LTE 38	QPSK20M	Rear Face	38150	1	0	Ant 0	Full	23.5	22.56	1.24	0.13	0.317	0.39
	2 CC (CA active)	LTE 38	QPSK20M	Rear Face	PCC:37850 SCC:38048	PCC:1 SCC:1	PCC:99 SCC:0	Ant 0	Full	23.5	22.48	1.26	-0.06	0.278	0.35

# FCC SAR Test Report

Plot No.	Band	Mode	Test Position	Ch.	Power Table	Duty Cycle	Crest Factor	Max. Tune-up Power (dBm)	Measured Conducted Power (dBm)	Scaling Factor	Power Drift (dB)	Measured SAR-1g (W/kg)	Scaled SAR-1g (W/kg)
	WLAN2.4G	802.11b	Front Face	11	3	100.00	1.00	19.5	19.10	1.10	0.05	0.132	0.15
	WLAN2.4G	802.11b	Rear Face	11	3	100.00	1.00	19.5	19.10	1.10	-0.03	0.127	0.14
	WLAN2.4G	802.11b	Front Face	1	3	100.00	1.00	19.5	18.60	1.23	0.12	0.108	0.13
27	WLAN2.4G	802.11b	Front Face	6	3	100.00	1.00	19.5	18.75	1.19	-0.13	0.134	<b>0.16</b>
	WLAN2.4G	802.11b	Front Face	11	1	100.00	1.00	16.5	16.09	1.10	0.02	0.055	0.06
	WLAN2.4G	802.11b	Rear Face	11	1	100.00	1.00	16.5	16.09	1.10	-0.08	0.053	0.06
	WLAN2.4G	802.11b	Front Face	1	1	100.00	1.00	16.5	15.57	1.24	-0.13	0.045	0.06
28	WLAN2.4G	802.11b	Front Face	6	1	100.00	1.00	16.5	15.51	1.26	-0.02	0.056	<b>0.07</b>
	WLAN5.3G	802.11n HT40	Front Face	62	1&3	98.40	1.02	12.5	11.92	1.14	-0.08	0.006	0.01
	WLAN5.3G	802.11n HT40	Rear Face	62	1&3	98.40	1.02	12.5	11.92	1.14	0.02	0.021	0.02
29	WLAN5.3G	802.11n HT40	Rear Face	54	1&3	98.40	1.02	12.5	11.75	1.19	-0.07	0.028	<b>0.03</b>
	WLAN5.6G	802.11n HT40	Front Face	110	1&3	98.40	1.02	12.5	12.49	1.00	-0.03	0.019	0.02
30	WLAN5.6G	802.11n HT40	Rear Face	110	1&3	98.40	1.02	12.5	12.49	1.00	0.04	0.022	<b>0.02</b>
	WLAN5.6G	802.11n HT40	Rear Face	102	1&3	98.40	1.02	12.5	12.34	1.04	0.12	0.021	0.02
	WLAN5.6G	802.11n HT40	Rear Face	118	1&3	98.40	1.02	12.5	12.47	1.01	0.05	0.019	0.02
	WLAN5.6G	802.11n HT40	Rear Face	126	1&3	98.40	1.02	12.5	12.27	1.05	-0.08	0.016	0.02
	WLAN5.6G	802.11n HT40	Rear Face	134	1&3	98.40	1.02	12.5	11.84	1.16	0.07	0.017	0.02
	WLAN5.6G	802.11n HT40	Rear Face	142	1&3	98.40	1.02	12.5	11.57	1.24	0.01	0.015	0.02
	WLAN5.8G	802.11n HT40	Front Face	159	1&3	98.40	1.02	12.5	12.24	1.06	0.14	0.00779	0.01
31	WLAN5.8G	802.11n HT40	Rear Face	159	1&3	98.40	1.02	12.5	12.24	1.06	-0.02	0.00981	<b>0.01</b>
	WLAN5.8G	802.11n HT40	Rear Face	151	1&3	98.40	1.02	12.5	12.12	1.09	0.06	0.00869	0.01
	BT	BDR	Front Face	0	-	100.00	1.00	12.0	10.92	1.28	-0.05	0.000788	0.00
	BT	BDR	Rear Face	0	-	100.00	1.00	12.0	10.92	1.28	0.12	0.000754	0.00
	BT	BDR	Front Face	39	-	100.00	1.00	12.0	10.59	1.38	0.07	0.000641	0.00
32	BT	BDR	Front Face	78	-	100.00	1.00	12.0	10.61	1.38	-0.03	0.000798	<b>0.00</b>

# FCC SAR Test Report

## 4.7.4 SAR Results for Hotspot Exposure Condition (Test Separation Distance is 10 mm)

Plot No.	Band	Mode	Test Position	Ch.	Tx Antenna	Power Table	Max. Tune-up Power (dBm)	Measured Conducted Power (dBm)	Scaling Factor	Power Drift (dB)	Measured SAR-1g (W/kg)	Scaled SAR-1g (W/kg)
	GSM850	GPRS12	Front Face	189	Ant 0	Full	27.5	26.33	1.31	0.05	0.113	0.15
	GSM850	GPRS12	Rear Face	189	Ant 0	Full	27.5	26.33	1.31	0.01	0.162	0.21
	GSM850	GPRS12	Left Side	189	Ant 0	Full	27.5	26.33	1.31	0	<0.001	0.00
	GSM850	GPRS12	Right Side	189	Ant 0	Full	27.5	26.33	1.31	0.05	0.061	0.08
	GSM850	GPRS12	Bottom Side	189	Ant 0	Full	27.5	26.33	1.31	-0.01	0.123	0.16
	GSM850	GPRS12	Front Face	189	Ant 1	Full	27.5	26.33	1.31	-0.13	0.159	0.21
	GSM850	GPRS12	Rear Face	189	Ant 1	Full	27.5	26.33	1.31	0.08	0.169	0.22
	GSM850	GPRS12	Left Side	189	Ant 1	Full	27.5	26.33	1.31	0.01	0.105	0.14
	GSM850	GPRS12	Top Side	189	Ant 1	Full	27.5	26.33	1.31	-0.03	0.143	0.19
33	GSM850	GPRS12	Rear Face	128	Ant 1	Full	27.5	26.22	1.34	-0.02	0.198	0.27
	GSM850	GPRS12	Rear Face	251	Ant 1	Full	27.5	26.31	1.32	0.14	0.195	0.26
	GSM1900	GPRS12	Front Face	661	Ant 0	7	22.0	20.92	1.28	-0.03	0.286	0.37
	GSM1900	GPRS12	Rear Face	661	Ant 0	7	22.0	20.92	1.28	0.01	0.381	0.49
	GSM1900	GPRS12	Left Side	661	Ant 0	7	22.0	20.92	1.28	0	<0.001	0.00
	GSM1900	GPRS12	Right Side	661	Ant 0	7	22.0	20.92	1.28	0.05	0.054	0.07
	GSM1900	GPRS12	Bottom Side	661	Ant 0	7	22.0	20.92	1.28	-0.02	0.665	0.85
	GSM1900	GPRS12	Front Face	661	Ant 1	7	24.0	22.79	1.32	0.02	0.156	0.21
	GSM1900	GPRS12	Rear Face	661	Ant 1	7	24.0	22.79	1.32	0.17	0.232	0.31
	GSM1900	GPRS12	Left Side	661	Ant 1	7	24.0	22.79	1.32	-0.18	0.205	0.27
	GSM1900	GPRS12	Top Side	661	Ant 1	7	24.0	22.79	1.32	-0.01	0.195	0.26
	GSM1900	GPRS12	Bottom Side	512	Ant 0	7	22.0	20.70	1.35	0.11	0.726	0.98
34	GSM1900	GPRS12	Bottom Side	810	Ant 0	7	22.0	20.64	1.37	-0.04	0.811	1.11
	GSM1900	GPRS12	Bottom Side	810	Ant 0	7	22.0	20.64	1.37	0.03	0.802	1.10
	WCDMA II	RMC12.2K	Front Face	9400	Ant 0	7	18.5	17.52	1.25	0.01	0.235	0.29
	WCDMA II	RMC12.2K	Rear Face	9400	Ant 0	7	18.5	17.52	1.25	-0.07	0.416	0.52
	WCDMA II	RMC12.2K	Left Side	9400	Ant 0	7	18.5	17.52	1.25	0	<0.001	0.00
	WCDMA II	RMC12.2K	Right Side	9400	Ant 0	7	18.5	17.52	1.25	0.02	0.067	0.08
35	WCDMA II	RMC12.2K	Bottom Side	9400	Ant 0	7	18.5	17.52	1.25	-0.05	0.753	0.94
	WCDMA II	RMC12.2K	Front Face	9400	Ant 1	7	21.0	19.87	1.30	-0.08	0.215	0.28
	WCDMA II	RMC12.2K	Rear Face	9400	Ant 1	7	21.0	19.87	1.30	-0.03	0.355	0.46
	WCDMA II	RMC12.2K	Left Side	9400	Ant 1	7	21.0	19.87	1.30	0.02	0.287	0.37
	WCDMA II	RMC12.2K	Top Side	9400	Ant 1	7	21.0	19.87	1.30	0.12	0.252	0.33
	WCDMA II	RMC12.2K	Bottom Side	9262	Ant 0	7	18.5	17.49	1.26	0.13	0.724	0.91
	WCDMA II	RMC12.2K	Bottom Side	9538	Ant 0	7	18.5	17.41	1.29	-0.06	0.722	0.93
	WCDMA IV	RMC12.2K	Front Face	1513	Ant 0	7	19.5	18.63	1.22	-0.11	0.247	0.30
	WCDMA IV	RMC12.2K	Rear Face	1513	Ant 0	7	19.5	18.63	1.22	0.05	0.368	0.45
	WCDMA IV	RMC12.2K	Left Side	1513	Ant 0	7	19.5	18.63	1.22	0.03	0.037	0.05
	WCDMA IV	RMC12.2K	Right Side	1513	Ant 0	7	19.5	18.63	1.22	-0.12	0.041	0.05
	WCDMA IV	RMC12.2K	Bottom Side	1513	Ant 0	7	19.5	18.63	1.22	0.04	0.593	0.72
	WCDMA IV	RMC12.2K	Front Face	1513	Ant 1	7	22.0	20.92	1.28	0.08	0.185	0.24
	WCDMA IV	RMC12.2K	Rear Face	1513	Ant 1	7	22.0	20.92	1.28	0.02	0.293	0.38
	WCDMA IV	RMC12.2K	Left Side	1513	Ant 1	7	22.0	20.92	1.28	-0.01	0.166	0.21
	WCDMA IV	RMC12.2K	Top Side	1513	Ant 1	7	22.0	20.92	1.28	0.13	0.281	0.36
	WCDMA IV	RMC12.2K	Bottom Side	1312	Ant 0	7	19.5	18.33	1.31	-0.03	0.559	0.73
36	WCDMA IV	RMC12.2K	Bottom Side	1413	Ant 0	7	19.5	18.52	1.25	-0.02	0.6	0.75

Note: The "< 0.001" means there is no SAR value or the SAR is too low to be measured.

# FCC SAR Test Report

Plot No.	Band	Mode	Test Position	Ch.	Tx Antenna	Power Table	Max. Tune-up Power (dBm)	Measured Conducted Power (dBm)	Scaling Factor	Power Drift (dB)	Measured SAR-1g (W/kg)	Scaled SAR-1g (W/kg)
	WCDMA V	RMC12.2K	Front Face	4233	Ant 0	Full	24.5	23.81	1.17	0.01	0.196	0.23
	WCDMA V	RMC12.2K	Rear Face	4233	Ant 0	Full	24.5	23.81	1.17	-0.03	0.27	0.32
	WCDMA V	RMC12.2K	Left Side	4233	Ant 0	Full	24.5	23.81	1.17	-0.05	0.065	0.08
	WCDMA V	RMC12.2K	Right Side	4233	Ant 0	Full	24.5	23.81	1.17	-0.11	0.076	0.09
	WCDMA V	RMC12.2K	Bottom Side	4233	Ant 0	Full	24.5	23.81	1.17	0.05	0.186	0.22
	WCDMA V	RMC12.2K	Front Face	4233	Ant 1	Full	24.5	23.81	1.17	0.02	0.241	0.28
37	WCDMA V	RMC12.2K	Rear Face	4233	Ant 1	Full	24.5	23.81	1.17	-0.03	0.271	0.32
	WCDMA V	RMC12.2K	Left Side	4233	Ant 1	Full	24.5	23.81	1.17	-0.15	0.192	0.22
	WCDMA V	RMC12.2K	Top Side	4233	Ant 1	Full	24.5	23.81	1.17	0.02	0.255	0.30
	WCDMA V	RMC12.2K	Rear Face	4132	Ant 1	Full	24.5	23.67	1.21	-0.15	0.171	0.21
	WCDMA V	RMC12.2K	Rear Face	4182	Ant 1	Full	24.5	23.79	1.18	-0.02	0.201	0.24

Plot No.	Band	Mode	Test Position	Ch.	RB#	RB Offset	Tx Antenna	Power Table	Max. Tune-up Power (dBm)	Measured Conducted Power (dBm)	Scaling Factor	Power Drift (dB)	Measured SAR-1g (W/kg)	Scaled SAR-1g (W/kg)
	LTE 2	QPSK20M	Front Face	18700	1	0	Ant 0	7	18.0	17.18	1.21	-0.03	0.269	0.33
	LTE 2	QPSK20M	Rear Face	18700	1	0	Ant 0	7	18.0	17.18	1.21	0.01	0.396	0.48
	LTE 2	QPSK20M	Left Side	18700	1	0	Ant 0	7	18.0	17.18	1.21	0	<0.001	0.00
	LTE 2	QPSK20M	Right Side	18700	1	0	Ant 0	7	18.0	17.18	1.21	-0.05	0.058	0.07
	LTE 2	QPSK20M	Bottom Side	18700	1	0	Ant 0	7	18.0	17.18	1.21	0.07	0.659	0.80
	LTE 2	QPSK20M	Front Face	18700	50	25	Ant 0	7	18.0	17.16	1.21	0.12	0.255	0.31
	LTE 2	QPSK20M	Rear Face	18700	50	25	Ant 0	7	18.0	17.16	1.21	-0.03	0.392	0.47
	LTE 2	QPSK20M	Left Side	18700	50	25	Ant 0	7	18.0	17.16	1.21	0	<0.001	0.00
	LTE 2	QPSK20M	Right Side	18700	50	25	Ant 0	7	18.0	17.16	1.21	-0.08	0.056	0.07
	LTE 2	QPSK20M	Bottom Side	18700	50	25	Ant 0	7	18.0	17.16	1.21	0.01	0.642	0.78
	LTE 2	QPSK20M	Front Face	18700	1	0	Ant 1	7	20.0	18.93	1.28	0.03	0.137	0.18
	LTE 2	QPSK20M	Rear Face	18700	1	0	Ant 1	7	20.0	18.93	1.28	0.08	0.247	0.32
	LTE 2	QPSK20M	Left Side	18700	1	0	Ant 1	7	20.0	18.93	1.28	0.19	0.181	0.23
	LTE 2	QPSK20M	Top Side	18700	1	0	Ant 1	7	20.0	18.93	1.28	0.14	0.191	0.24
	LTE 2	QPSK20M	Front Face	18700	50	25	Ant 1	7	20.0	18.91	1.29	0.03	0.138	0.18
	LTE 2	QPSK20M	Rear Face	18700	50	25	Ant 1	7	20.0	18.91	1.29	0.17	0.196	0.25
	LTE 2	QPSK20M	Left Side	18700	50	25	Ant 1	7	20.0	18.91	1.29	0.02	0.145	0.19
	LTE 2	QPSK20M	Top Side	18700	50	25	Ant 1	7	20.0	18.91	1.29	0.05	0.148	0.19
	LTE 2	QPSK20M	Bottom Side	18900	1	0	Ant 0	7	18.0	16.93	1.28	-0.01	0.66	0.84
38	LTE 2	QPSK20M	Bottom Side	19100	1	0	Ant 0	7	18.0	16.89	1.29	-0.07	0.676	0.87
	LTE 2	QPSK20M	Bottom Side	18700	100	0	Ant 0	7	18.0	17.14	1.22	-0.07	0.623	0.76

Note: The "< 0.001" means there is no SAR value or the SAR is too low to be measured.



# FCC SAR Test Report

Plot No.	Band	Mode	Test Position	Ch.	RB#	RB Offset	Tx Antenna	Power Table	Max. Tune-up Power (dBm)	Measured Conducted Power (dBm)	Scaling Factor	Power Drift (dB)	Measured SAR-1g (W/kg)	Scaled SAR-1g (W/kg)
	LTE 4	QPSK20M	Front Face	20050	1	0	Ant 0	7	20.0	18.83	1.31	-0.08	0.251	0.33
	LTE 4	QPSK20M	Rear Face	20050	1	0	Ant 0	7	20.0	18.83	1.31	0.03	0.376	0.49
	LTE 4	QPSK20M	Left Side	20050	1	0	Ant 0	7	20.0	18.83	1.31	0.01	0.042	0.06
	LTE 4	QPSK20M	Right Side	20050	1	0	Ant 0	7	20.0	18.83	1.31	-0.05	0.041	0.05
	LTE 4	QPSK20M	Bottom Side	20050	1	0	Ant 0	7	20.0	18.83	1.31	0.07	0.616	0.81
	LTE 4	QPSK20M	Front Face	20050	50	50	Ant 0	7	20.0	18.80	1.32	0.12	0.245	0.32
	LTE 4	QPSK20M	Rear Face	20050	50	50	Ant 0	7	20.0	18.80	1.32	-0.06	0.347	0.46
	LTE 4	QPSK20M	Left Side	20050	50	50	Ant 0	7	20.0	18.80	1.32	0.01	0.039	0.05
	LTE 4	QPSK20M	Right Side	20050	50	50	Ant 0	7	20.0	18.80	1.32	0.08	0.037	0.05
	LTE 4	QPSK20M	Bottom Side	20050	50	50	Ant 0	7	20.0	18.80	1.32	-0.02	0.596	0.79
	LTE 4	QPSK20M	Front Face	20050	1	0	Ant 1	7	22.0	20.73	1.34	0.16	0.147	0.20
	LTE 4	QPSK20M	Rear Face	20050	1	0	Ant 1	7	22.0	20.73	1.34	0.02	0.198	0.27
	LTE 4	QPSK20M	Left Side	20050	1	0	Ant 1	7	22.0	20.73	1.34	0.03	0.139	0.19
	LTE 4	QPSK20M	Top Side	20050	1	0	Ant 1	7	22.0	20.73	1.34	-0.18	0.195	0.26
	LTE 4	QPSK20M	Front Face	20050	50	50	Ant 1	7	22.0	20.70	1.35	0.02	0.116	0.16
	LTE 4	QPSK20M	Rear Face	20050	50	50	Ant 1	7	22.0	20.70	1.35	0.11	0.182	0.25
	LTE 4	QPSK20M	Left Side	20050	50	50	Ant 1	7	22.0	20.70	1.35	-0.12	0.116	0.16
	LTE 4	QPSK20M	Top Side	20050	50	50	Ant 1	7	22.0	20.70	1.35	-0.01	0.156	0.21
	LTE 4	QPSK20M	Bottom Side	20175	1	0	Ant 0	7	20.0	18.79	1.32	0.15	0.615	0.81
39	LTE 4	QPSK20M	Bottom Side	20300	1	0	Ant 0	7	20.0	18.74	1.34	-0.04	0.646	0.87
	LTE 4	QPSK20M	Bottom Side	20050	100	0	Ant 0	7	20.0	18.71	1.35	0.03	0.595	0.80
	LTE 5	QPSK10M	Front Face	20525	1	0	Ant 0	Full	23.5	22.30	1.32	0.07	0.101	0.13
	LTE 5	QPSK10M	Rear Face	20525	1	0	Ant 0	Full	23.5	22.30	1.32	-0.02	0.143	0.19
	LTE 5	QPSK10M	Left Side	20525	1	0	Ant 0	Full	23.5	22.30	1.32	0.11	0.077	0.10
	LTE 5	QPSK10M	Right Side	20525	1	0	Ant 0	Full	23.5	22.30	1.32	0.05	0.124	0.16
	LTE 5	QPSK10M	Bottom Side	20525	1	0	Ant 0	Full	23.5	22.30	1.32	-0.03	0.107	0.14
	LTE 5	QPSK10M	Front Face	20525	25	0	Ant 0	Full	22.5	21.39	1.29	0.09	0.079	0.10
	LTE 5	QPSK10M	Rear Face	20525	25	0	Ant 0	Full	22.5	21.39	1.29	0.02	0.123	0.16
	LTE 5	QPSK10M	Left Side	20525	25	0	Ant 0	Full	22.5	21.39	1.29	-0.08	0.042	0.05
	LTE 5	QPSK10M	Right Side	20525	25	0	Ant 0	Full	22.5	21.39	1.29	0.01	0.059	0.08
	LTE 5	QPSK10M	Bottom Side	20525	25	0	Ant 0	Full	22.5	21.39	1.29	-0.05	0.104	0.13
	LTE 5	QPSK10M	Front Face	20525	1	0	Ant 1	Full	23.5	22.30	1.32	-0.03	0.156	0.21
	LTE 5	QPSK10M	Rear Face	20525	1	0	Ant 1	Full	23.5	22.30	1.32	0.08	0.165	0.22
	LTE 5	QPSK10M	Left Side	20525	1	0	Ant 1	Full	23.5	22.30	1.32	0.11	0.088	0.12
	LTE 5	QPSK10M	Top Side	20525	1	0	Ant 1	Full	23.5	22.30	1.32	-0.05	0.157	0.21
	LTE 5	QPSK10M	Front Face	20525	25	0	Ant 1	Full	22.5	21.39	1.29	0.01	0.134	0.17
	LTE 5	QPSK10M	Rear Face	20525	25	0	Ant 1	Full	22.5	21.39	1.29	-0.03	0.147	0.19
	LTE 5	QPSK10M	Left Side	20525	25	0	Ant 1	Full	22.5	21.39	1.29	0.01	0.064	0.08
	LTE 5	QPSK10M	Top Side	20525	25	0	Ant 1	Full	22.5	21.39	1.29	0.05	0.115	0.15
40	LTE 5	QPSK10M	Rear Face	20450	1	0	Ant 1	Full	23.5	22.25	1.33	-0.06	0.174	0.23
	LTE 5	QPSK10M	Rear Face	20600	1	0	Ant 1	Full	23.5	22.24	1.34	-0.12	0.169	0.23

# FCC SAR Test Report

Plot No.	Uplink Mode	Band	Mode	Test Position	Ch.	RB#	RB Offset	Tx Antenna	Power Table	Max. Tune-up Power (dBm)	Measured Conducted Power (dBm)	Scaling Factor	Power Drift (dB)	Measured SAR-1g (W/kg)	Scaled SAR-1g (W/kg)
	Single Carrier (CA inactive)	LTE 7	QPSK20M	Front Face	21100	1	50	Ant 0	7	22.0	20.86	1.30	-0.06	0.528	0.69
		LTE 7	QPSK20M	Rear Face	21100	1	50	Ant 0	7	22.0	20.86	1.30	0.03	0.609	0.79
		LTE 7	QPSK20M	Left Side	21100	1	50	Ant 0	7	22.0	20.86	1.30	0.11	0.361	0.47
		LTE 7	QPSK20M	Right Side	21100	1	50	Ant 0	7	22.0	20.86	1.30	0.05	0.183	0.24
		LTE 7	QPSK20M	Bottom Side	21100	1	50	Ant 0	7	22.0	20.86	1.30	0.09	0.775	1.01
		LTE 7	QPSK20M	Front Face	21100	50	50	Ant 0	7	22.0	20.83	1.31	-0.02	0.521	0.68
		LTE 7	QPSK20M	Rear Face	21100	50	50	Ant 0	7	22.0	20.83	1.31	0.07	0.595	0.78
		LTE 7	QPSK20M	Left Side	21100	50	50	Ant 0	7	22.0	20.83	1.31	0.01	0.357	0.47
		LTE 7	QPSK20M	Right Side	21100	50	50	Ant 0	7	22.0	20.83	1.31	-0.03	0.174	0.23
		LTE 7	QPSK20M	Bottom Side	21100	50	50	Ant 0	7	22.0	20.83	1.31	-0.05	0.767	1.00
		LTE 7	QPSK20M	Front Face	21100	1	50	Ant 1	7	17.5	16.62	1.22	0.12	0.123	0.15
		LTE 7	QPSK20M	Rear Face	21100	1	50	Ant 1	7	17.5	16.62	1.22	-0.01	0.111	0.14
		LTE 7	QPSK20M	Left Side	21100	1	50	Ant 1	7	17.5	16.62	1.22	0.05	0.211	0.26
		LTE 7	QPSK20M	Top Side	21100	1	50	Ant 1	7	17.5	16.62	1.22	-0.02	0.074	0.09
		LTE 7	QPSK20M	Front Face	21100	50	50	Ant 1	7	17.5	16.52	1.25	0.01	0.103	0.13
		LTE 7	QPSK20M	Rear Face	21100	50	50	Ant 1	7	17.5	16.52	1.25	0.09	0.094	0.12
		LTE 7	QPSK20M	Left Side	21100	50	50	Ant 1	7	17.5	16.52	1.25	-0.13	0.189	0.24
		LTE 7	QPSK20M	Top Side	21100	50	50	Ant 1	7	17.5	16.52	1.25	0.08	0.066	0.08
41		LTE 7	QPSK20M	Bottom Side	20850	1	50	Ant 0	7	22.0	20.83	1.31	-0.04	0.822	1.08
		LTE 7	QPSK20M	Bottom Side	21350	1	50	Ant 0	7	22.0	20.82	1.31	0.05	0.732	0.96
	LTE 7	QPSK20M	Bottom Side	20850	50	50	Ant 0	7	22.0	20.80	1.32	-0.11	0.809	1.07	
	LTE 7	QPSK20M	Bottom Side	21350	50	50	Ant 0	7	22.0	20.79	1.32	0.03	0.721	0.95	
	LTE 7	QPSK20M	Bottom Side	21100	100	0	Ant 0	7	22.0	20.82	1.31	-0.08	0.713	0.93	
	LTE 7	QPSK20M	Bottom Side	20850	1	50	Ant 0	7	22.0	20.83	1.31	0.05	0.806	1.06	
	2 CC (CA active)	LTE 7	QPSK20M	Bottom Side	PCC:21001 SCC:21199	PCC:1 SCC:1	PCC:99 SCC:0	Ant 0	7	22.0	20.60	1.38	0.07	0.523	0.72

# FCC SAR Test Report

Plot No.	Uplink Mode	Band	Mode	Test Position	Ch.	RB#	RB Offset	Tx Antenna	Power Table	Max. Tune-up Power (dBm)	Measured Conducted Power (dBm)	Scaling Factor	Power Drift (dB)	Measured SAR-1g (W/kg)	Scaled SAR-1g (W/kg)
42	Single Carrier (CA inactive)	LTE 38	QPSK20M	Front Face	37850	1	0	Ant 0	Full	23.5	22.62	1.22	0.07	0.443	0.54
		LTE 38	QPSK20M	Rear Face	37850	1	0	Ant 0	Full	23.5	22.62	1.22	-0.1	0.545	0.66
		LTE 38	QPSK20M	Left Side	37850	1	0	Ant 0	Full	23.5	22.62	1.22	-0.18	0.389	0.47
		LTE 38	QPSK20M	Right Side	37850	1	0	Ant 0	Full	23.5	22.62	1.22	-0.11	0.139	0.17
		LTE 38	QPSK20M	Bottom Side	37850	1	0	Ant 0	Full	23.5	22.62	1.22	0.01	0.829	1.01
		LTE 38	QPSK20M	Front Face	37850	50	25	Ant 0	Full	22.5	21.54	1.25	0.02	0.401	0.50
		LTE 38	QPSK20M	Rear Face	37850	50	25	Ant 0	Full	22.5	21.54	1.25	-0.15	0.503	0.63
		LTE 38	QPSK20M	Left Side	37850	50	25	Ant 0	Full	22.5	21.54	1.25	0.11	0.331	0.41
		LTE 38	QPSK20M	Right Side	37850	50	25	Ant 0	Full	22.5	21.54	1.25	-0.12	0.121	0.15
		LTE 38	QPSK20M	Bottom Side	37850	50	25	Ant 0	Full	22.5	21.54	1.25	0.02	0.631	0.79
		LTE 38	QPSK20M	Front Face	37850	1	0	Ant 1	7	19.5	18.11	1.38	0.08	0.165	0.23
		LTE 38	QPSK20M	Rear Face	37850	1	0	Ant 1	7	19.5	18.11	1.38	-0.15	0.142	0.20
		LTE 38	QPSK20M	Left Side	37850	1	0	Ant 1	7	19.5	18.11	1.38	-0.01	0.341	0.47
		LTE 38	QPSK20M	Top Side	37850	1	0	Ant 1	7	19.5	18.11	1.38	-0.06	0.166	0.23
		LTE 38	QPSK20M	Front Face	37850	50	25	Ant 1	7	19.5	18.08	1.39	0.17	0.136	0.19
		LTE 38	QPSK20M	Rear Face	37850	50	25	Ant 1	7	19.5	18.08	1.39	0.03	0.145	0.20
		LTE 38	QPSK20M	Left Side	37850	50	25	Ant 1	7	19.5	18.08	1.39	-0.08	0.246	0.34
		LTE 38	QPSK20M	Top Side	37850	50	25	Ant 1	7	19.5	18.08	1.39	0.16	0.102	0.14
		LTE 38	QPSK20M	Bottom Side	38000	1	0	Ant 0	Full	23.5	22.45	1.27	-0.1	0.791	1.00
		LTE 38	QPSK20M	Bottom Side	38150	1	0	Ant 0	Full	23.5	22.56	1.24	-0.03	0.786	0.97
LTE 38	QPSK20M	Bottom Side	37850	100	0	Ant 0	Full	22.5	21.54	1.25	-0.15	0.627	0.78		
LTE 38	QPSK20M	Bottom Side	37850	1	0	Ant 0	Full	23.5	22.62	1.22	0.01	0.822	1.00		
2 CC (CA active)		LTE 38	QPSK20M	Bottom Side	PCC:37850 SCC:38048	PCC:1 SCC:1	PCC:99 SCC:0	Ant 0	Full	23.5	22.48	1.26	-0.03	0.661	0.83
		LTE 38	QPSK20M	Bottom Side	PCC:37901 SCC:38099	PCC:1 SCC:1	PCC:99 SCC:0	Ant 0	Full	23.5	22.31	1.32	0.02	0.581	0.77
		LTE 38	QPSK20M	Bottom Side	PCC:37952 SCC:38150	PCC:1 SCC:1	PCC:99 SCC:0	Ant 0	Full	23.5	22.41	1.29	-0.15	0.587	0.76

Plot No.	Band	Mode	Test Position	Ch.	Power Table	Duty Cycle	Crest Factor	Max. Tune-up Power (dBm)	Measured Conducted Power (dBm)	Scaling Factor	Power Drift (dB)	Measured SAR-1g (W/kg)	Scaled SAR-1g (W/kg)
	WLAN2.4G	802.11b	Front Face	11	5	100.00	1.00	15.0	14.56	1.11	-0.14	0.0891	0.10
	WLAN2.4G	802.11b	Rear Face	11	5	100.00	1.00	15.0	14.56	1.11	-0.08	0.064	0.07
	WLAN2.4G	802.11b	Right Side	11	Full	100.00	1.00	19.5	19.10	1.10	0.05	0.544	0.60
	WLAN2.4G	802.11b	Top Side	11	Full	100.00	1.00	19.5	19.10	1.10	0.12	0.118	0.13
43	WLAN2.4G	802.11b	Right Side	1	Full	100.00	1.00	19.5	18.60	1.23	0.06	0.407	0.50
	WLAN2.4G	802.11b	Right Side	6	Full	100.00	1.00	19.5	18.75	1.19	0.08	0.577	0.69
	WLAN5.2G	802.11n HT40	Front Face	46	5	98.40	1.02	12.5	11.46	1.27	-0.09	0.0153	0.02
	WLAN5.2G	802.11n HT40	Rear Face	46	5	98.40	1.02	12.5	11.46	1.27	-0.09	0.086	0.11
	WLAN5.2G	802.11a	Right Side	48	Full	96.20	1.04	17.5	17.05	1.11	0.12	0.188	0.22
	WLAN5.2G	802.11a	Top Side	48	Full	96.20	1.04	17.5	17.05	1.11	0.02	0.121	0.14
	WLAN5.2G	802.11a	Right Side	36	Full	96.20	1.04	17.5	16.64	1.22	0.05	0.166	0.21
	WLAN5.2G	802.11a	Right Side	40	Full	96.20	1.04	17.5	16.75	1.19	-0.01	0.177	0.22
	WLAN5.2G	802.11a	Right Side	44	Full	96.20	1.04	17.5	17.01	1.12	-0.09	0.152	0.18
	WLAN5.8G	802.11n HT40	Front Face	159	5	98.40	1.02	12.5	12.24	1.06	-0.06	0.0159	0.02
	WLAN5.8G	802.11n HT40	Rear Face	159	5	98.40	1.02	12.5	12.24	1.06	0.03	0.023	0.02
	WLAN5.8G	802.11a	Right Side	161	Full	96.20	1.04	17.5	17.42	1.02	-0.13	0.271	0.29
	WLAN5.8G	802.11a	Top Side	161	Full	96.20	1.04	17.5	17.42	1.02	0.08	0.042	0.04
WLAN5.8G	802.11a	Right Side	149	Full	96.20	1.04	17.5	17.21	1.07	-0.05	0.298	0.33	
WLAN5.8G	802.11a	Right Side	153	Full	96.20	1.04	17.5	17.32	1.04	0.11	0.297	0.32	
WLAN5.8G	802.11a	Right Side	157	Full	96.20	1.04	17.5	17.34	1.04	0.05	0.278	0.30	
WLAN5.8G	802.11a	Right Side	165	Full	96.20	1.04	17.5	17.35	1.04	-0.03	0.261	0.28	

# FCC SAR Test Report

Plot No.	Band	Mode	Test Position	Ch.	Power Table	Duty Cycle	Crest Factor	Max. Tune-up Power (dBm)	Measured Conducted Power (dBm)	Scaling Factor	Power Drift (dB)	Measured SAR-1g (W/kg)	Scaled SAR-1g (W/kg)
	BT	BDR	Front Face	0	-	100.00	1.00	12.0	10.92	1.28	0.03	0.00274	0.00
	BT	BDR	Rear Face	0	-	100.00	1.00	12.0	10.92	1.28	0.05	0.00248	0.00
	BT	BDR	Right Side	0	-	100.00	1.00	12.0	10.92	1.28	-0.11	0.00552	0.01
	BT	BDR	Top Side	0	-	100.00	1.00	12.0	10.92	1.28	0.05	0.00119	0.00
	BT	BDR	Right Side	39	-	100.00	1.00	12.0	10.59	1.38	0.13	0.00411	0.01
46	BT	BDR	Right Side	78	-	100.00	1.00	12.0	10.61	1.38	-0.03	0.00583	0.01

## 4.7.5 SAR Results for Product Specific (Phablet) Exposure Condition (Test Separation Distance is 0 mm)

Plot No.	Band	Mode	Test Position	Ch.	Tx Antenna	Power Table	Max. Tune-up Power (dBm)	Measured Conducted Power (dBm)	Scaling Factor	Power Drift (dB)	Measured SAR-10g (W/kg)	Scaled SAR-10g (W/kg)
	GSM1900	GPRS12	Bottom Side	661	Ant 0	5&6	24.5	22.95	1.43	0.05	1.19	1.70
	GSM1900	GPRS12	Bottom Side	512	Ant 0	5&6	24.5	22.93	1.44	-0.11	1.17	1.68
47	GSM1900	GPRS12	Bottom Side	810	Ant 0	5&6	24.5	22.69	1.52	-0.15	1.16	1.76
	WCDMA II	RMC12.2K	Rear Face	9400	Ant 0	5&6	21.5	20.02	1.41	-0.15	2.16	3.05
	WCDMA II	RMC12.2K	Bottom Side	9400	Ant 0	5&6	21.5	20.02	1.41	0.03	1.57	2.21
	WCDMA II	RMC12.2K	Front Face	9262	Ant 0	5&6	21.5	19.95	1.43	-0.17	1.99	2.85
48	WCDMA II	RMC12.2K	Rear Face	9262	Ant 0	5&6	21.5	19.95	1.43	0.03	2.2	3.15
	WCDMA II	RMC12.2K	Rear Face	9538	Ant 0	5&6	21.5	19.98	1.42	0.05	2.01	2.85
	WCDMA II	RMC12.2K	Bottom Side	9262	Ant 0	5&6	21.5	19.95	1.43	0.03	1.68	2.40
	WCDMA II	RMC12.2K	Bottom Side	9538	Ant 0	5&6	21.5	19.98	1.42	0.03	1.51	2.14
	WCDMA II	RMC12.2K	Rear Face	9262	Ant 0	5&6	21.5	19.95	1.43	0.02	2.18	3.12
	WCDMA IV	RMC12.2K	Bottom Side	1513	Ant 0	5&6	21.5	20.01	1.41	0.08	2.03	2.86
	WCDMA IV	RMC12.2K	Bottom Side	1312	Ant 0	5&6	21.5	19.87	1.46	0.11	2.11	3.08
49	WCDMA IV	RMC12.2K	Bottom Side	1413	Ant 0	5&6	21.5	19.98	1.42	-0.15	2.19	3.11
	WCDMA IV	RMC12.2K	Bottom Side	1413	Ant 0	5&6	21.5	19.98	1.42	0.02	2.17	3.08

Plot No.	Band	Mode	Test Position	Ch.	RB#	RB Offset	Tx Antenna	Power Table	Max. Tune-up Power (dBm)	Measured Conducted Power (dBm)	Scaling Factor	Power Drift (dB)	Measured SAR-10g (W/kg)	Scaled SAR-10g (W/kg)
50	LTE 2	QPSK20M	Rear Face	18700	1	0	Ant 0	5&6	21.5	20.69	1.21	0.06	1.9	2.30
	LTE 2	QPSK20M	Bottom Side	18700	1	0	Ant 0	5&6	21.5	20.69	1.21	0.13	1.47	1.78
	LTE 2	QPSK20M	Rear Face	18700	50	25	Ant 0	5&6	21.5	20.62	1.22	-0.01	1.77	2.16
	LTE 2	QPSK20M	Bottom Side	18700	50	25	Ant 0	5&6	21.5	20.62	1.22	-0.16	1.45	1.77
	LTE 2	QPSK20M	Rear Face	18900	1	0	Ant 0	5&6	21.5	20.65	1.22	-0.08	1.79	2.18
	LTE 2	QPSK20M	Rear Face	19100	1	0	Ant 0	5&6	21.5	20.63	1.22	-0.06	1.73	2.11
	LTE 2	QPSK20M	Rear Face	18900	50	25	Ant 0	5&6	21.5	20.55	1.24	0.15	1.73	2.15
	LTE 2	QPSK20M	Rear Face	19100	50	25	Ant 0	5&6	21.5	20.52	1.25	0.18	1.65	2.06
	LTE 2	QPSK20M	Rear Face	18700	100	0	Ant 0	5&6	21.5	20.54	1.25	0.02	1.71	2.14
	LTE 2	QPSK20M	Rear Face	18700	1	0	Ant 0	5&6	21.5	20.69	1.21	0.01	1.82	2.20
51	LTE 4	QPSK20M	Bottom Side	20050	1	0	Ant 0	5&6	22.0	21.09	1.23	0.16	2.35	2.89
	LTE 4	QPSK20M	Bottom Side	20050	50	50	Ant 0	5&6	22.0	21.04	1.25	0.02	2.3	2.88
	LTE 4	QPSK20M	Bottom Side	20175	1	0	Ant 0	5&6	22.0	21.08	1.24	0.15	2.18	2.70
	LTE 4	QPSK20M	Bottom Side	20300	1	0	Ant 0	5&6	22.0	20.93	1.28	-0.02	2.25	2.88
	LTE 4	QPSK20M	Bottom Side	20175	50	50	Ant 0	5&6	22.0	21.03	1.25	0.15	2.26	2.83
	LTE 4	QPSK20M	Bottom Side	20300	50	50	Ant 0	5&6	22.0	20.90	1.29	0.02	2.23	2.88
	LTE 4	QPSK20M	Bottom Side	20050	100	0	Ant 0	5&6	22.0	21.05	1.24	0.05	2.32	2.88
	LTE 4	QPSK20M	Bottom Side	20050	1	0	Ant 0	5&6	22.0	21.09	1.23	0.15	2.27	2.79

# FCC SAR Test Report

Plot No.	Uplink Mode	Band	Mode	Test Position	Ch.	RB#	RB Offset	Tx Antenna	Power Table	Max. Tune-up Power (dBm)	Measured Conducted Power (dBm)	Scaling Factor	Power Drift (dB)	Measured SAR-10g (W/kg)	Scaled SAR-10g (W/kg)
52	Single Carrier (CA inactive)	LTE 7	QPSK20M	Bottom Side	21100	1	50	Ant 0	5&6	22.0	21.12	1.22	0.01	2.31	2.82
		LTE 7	QPSK20M	Bottom Side	21100	50	50	Ant 0	5&6	22.0	20.97	1.27	-0.08	2.28	2.90
		LTE 7	QPSK20M	Bottom Side	20850	1	50	Ant 0	5&6	22.0	20.93	1.28	0.15	2.36	3.02
		LTE 7	QPSK20M	Bottom Side	21350	1	50	Ant 0	5&6	22.0	20.95	1.27	0.17	2.21	2.81
		LTE 7	QPSK20M	Bottom Side	20850	50	50	Ant 0	5&6	22.0	20.88	1.29	-0.08	2.33	3.01
		LTE 7	QPSK20M	Bottom Side	21350	50	50	Ant 0	5&6	22.0	20.91	1.29	0.15	2.27	2.93
		LTE 7	QPSK20M	Bottom Side	21100	100	0	Ant 0	5&6	22.0	20.96	1.27	0.11	2.26	2.87
		LTE 7	QPSK20M	Bottom Side	20850	1	50	Ant 0	5&6	22.0	20.93	1.28	0.12	2.28	2.92
2 CC (CA active)		LTE 7	QPSK20M	Bottom Side	PCC:21001 SCC:21199	PCC:1 SCC:1	PCC:99 SCC:0	Ant 0	5&6	22.0	20.84	1.31	0.12	2.02	2.65
		LTE 7	QPSK20M	Bottom Side	PCC:20850 SCC:21048	PCC:1 SCC:1	PCC:99 SCC:0	Ant 0	5&6	22.0	20.80	1.32	-0.08	2.09	2.76
		LTE 7	QPSK20M	Bottom Side	PCC:21152 SCC:21350	PCC:1 SCC:1	PCC:99 SCC:0	Ant 0	5&6	22.0	20.73	1.34	0.03	1.98	2.65

Plot No.	Band	Mode	Test Position	Ch.	Power Table	Duty Cycle	Crest Factor	Max. Tune-up Power (dBm)	Measured Conducted Power (dBm)	Scaling Factor	Power Drift (dB)	Measured SAR-10g (W/kg)	Scaled SAR-10g (W/kg)
	WLAN5.3G	802.11n HT40	Front Face	62	1&4	98.40	1.02	12.5	11.92	1.14	-0.02	0.101	0.12
	WLAN5.3G	802.11n HT40	Rear Face	62	1&4	98.40	1.02	12.5	11.92	1.14	0.05	0.074	0.09
53	WLAN5.3G	802.11a	Right Side	60	Full	96.20	1.04	17.5	17.25	1.06	-0.09	0.737	0.81
	WLAN5.3G	802.11a	Top Side	60	Full	96.20	1.04	17.5	17.25	1.06	0.12	0.154	0.17
	WLAN5.3G	802.11a	Right Side	52	Full	96.20	1.04	17.5	17.05	1.11	0.05	0.616	0.71
	WLAN5.3G	802.11a	Right Side	56	Full	96.20	1.04	17.5	17.21	1.07	-0.08	0.692	0.77
	WLAN5.3G	802.11a	Right Side	64	Full	96.20	1.04	17.5	17.21	1.07	0.01	0.673	0.75
	WLAN5.6G	802.11n HT40	Front Face	110	1&4	98.40	1.02	12.5	12.49	1.00	-0.05	0.221	0.23
54	WLAN5.6G	802.11n HT40	Rear Face	110	1&4	98.40	1.02	12.5	12.49	1.00	-0.09	0.157	0.16
	WLAN5.6G	802.11a	Right Side	100	Full	96.20	1.04	18.5	18.07	1.10	0.02	1.290	1.48
	WLAN5.6G	802.11a	Top Side	100	Full	96.20	1.04	18.5	18.07	1.10	-0.06	0.346	0.40
	WLAN5.6G	802.11a	Right Side	116	Full	96.20	1.04	18.5	17.93	1.14	-0.03	1.33	1.58
	WLAN5.6G	802.11a	Right Side	120	Full	96.20	1.04	18.5	17.62	1.22	-0.03	1.130	1.43
	WLAN5.6G	802.11a	Right Side	124	Full	96.20	1.04	18.5	17.44	1.28	0.15	1.160	1.54
	WLAN5.6G	802.11a	Right Side	132	Full	96.20	1.04	18.5	17.12	1.37	0.01	0.993	1.41
	WLAN5.6G	802.11a	Right Side	140	Full	96.20	1.04	18.5	17.25	1.33	-0.08	1.040	1.44
	WLAN5.6G	802.11a	Right Side	144	Full	96.20	1.04	18.5	16.90	1.45	0.02	0.918	1.38

**4.7.6 SAR Measurement Variability**

According to KDB 865664 D01, SAR measurement variability was assessed for each frequency band, which is determined by the SAR probe calibration point and tissue-equivalent medium used for the device measurements. When both head and body tissue-equivalent media are required for SAR measurements in a frequency band, the variability measurement procedures should be applied to the tissue medium with the highest measured SAR, using the highest measured SAR configuration for that tissue-equivalent medium. Alternatively, if the highest measured SAR for both head and body tissue-equivalent media are  $\leq 1.45$  W/kg and the ratio of these highest SAR values, i.e., largest divided by smallest value, is  $\leq 1.10$ , the highest SAR configuration for either head or body tissue-equivalent medium maybe used to perform the repeated measurement. These additional measurements are repeated after the completion of all measurements requiring the same head or body tissue-equivalent medium in a frequency band. The test device should be returned to ambient conditions (normal room temperature) with the battery fully charged before it is re-mounted on the device holder for the repeated measurement(s) to minimize any unexpected variations in the repeated results.

SAR repeated measurement procedure:

1. When the highest measured SAR is  $< 0.80$  W/kg, repeated measurement is not required.
2. When the highest measured SAR is  $\geq 0.80$  W/kg, repeat that measurement once.
3. If the ratio of largest to smallest SAR for the original and first repeated measurements is  $> 1.20$ , or when the original or repeated measurement is  $\geq 1.45$  W/kg, perform a second repeated measurement.
4. If the ratio of largest to smallest SAR for the original, first and second repeated measurements is  $> 1.20$ , and the original, first or second repeated measurement is  $\geq 1.5$  W/kg, perform a third repeated measurement.
5. The same procedures should be adapted for measurements according to extremity and occupational exposure limits by applying a factor of 2.5 for extremity exposure and a factor of 5 for occupational exposure to the corresponding SAR thresholds.

Band	Mode	Test Position	Ch.	Original Measured SAR-1g (W/kg)	1st Repeated SAR-1g (W/kg)	L/S Ratio	2nd Repeated SAR-1g (W/kg)	L/S Ratio	3rd Repeated SAR-1g (W/kg)	L/S Ratio
WCDMA II	RMC12.2K	Right Tilted	9400	0.913	0.905	1.01	N/A	N/A	N/A	N/A
WCDMA IV	RMC12.2K	Right Tilted	1513	0.892	0.882	1.01	N/A	N/A	N/A	N/A
LTE 38	QPSK20M	Right Cheek	38150	0.824	0.815	1.01	N/A	N/A	N/A	N/A
WLAN2.4G	802.11b	Left Cheek	11	1.08	1.05	1.03	N/A	N/A	N/A	N/A
WCDMA II	RMC12.2K	Rear Face	9262	0.802	0.795	1.01	N/A	N/A	N/A	N/A
GSM1900	GPRS12	Bottom Side	810	0.811	0.802	1.01	N/A	N/A	N/A	N/A
LTE 7	QPSK20M	Bottom Side	20850	0.822	0.806	1.02	N/A	N/A	N/A	N/A
LTE 38	QPSK20M	Bottom Side	37850	0.829	0.822	1.01	N/A	N/A	N/A	N/A

Band	Mode	Test Position	Ch.	Original Measured SAR-10g (W/kg)	1st Repeated SAR-10g (W/kg)	L/S Ratio	2nd Repeated SAR-1g (W/kg)	L/S Ratio	3rd Repeated SAR-1g (W/kg)	L/S Ratio
WCDMA II	RMC12.2K	Rear Face	9262	2.2	2.18	1.01	N/A	N/A	N/A	N/A
WCDMA IV	RMC12.2K	Bottom Side	1413	2.19	2.17	1.01	N/A	N/A	N/A	N/A
LTE 4	QPSK20M	Bottom Side	20050	2.35	2.27	1.04	N/A	N/A	N/A	N/A
LTE 7	QPSK20M	Rear Face	20850	2.36	2.28	1.04	N/A	N/A	N/A	N/A

# FCC SAR Test Report

## 4.7.7 Simultaneous Multi-band Transmission Evaluation

### <Possibilities of Simultaneous Transmission>

The simultaneous transmission possibilities for this device are listed as below.

Simultaneous TX Combination	Capable Transmit Configurations	Head Exposure Condition	Body Exposure Condition	Hotspot Exposure Condition
1	WWAN + WLAN 2.4G	Yes	Yes	Yes
2	WWAN + WLAN 5G	Yes	Yes	Yes
3	WWAN + BT	Yes	Yes	Yes
4	WLAN 5G + BT	Yes	Yes	Yes
5	WWAN + WLAN 5G + BT	Yes	Yes	Yes

#### Note :

1. The WLAN 2.4G and WLAN 5G cannot transmit simultaneously.
2. Plot3 is covered by plot5
3. Plot4 is covered by plot5

# FCC SAR Test Report

## <SAR Summation Analysis>

Simultaneous transmission SAR test exclusion is determined for each operating configuration and exposure condition according to the reported standalone SAR of each applicable simultaneous transmitting antenna. When the sum of SAR<sub>1g</sub> of all simultaneously transmitting antennas in an operating mode and exposure condition combination is within the SAR limit(SAR<sub>1g</sub> 1.6 W/kg), the simultaneous transmission SAR is not required. When the sum of SAR<sub>1g</sub> is greater than the SAR limit (SAR<sub>1g</sub> 1.6 W/kg), SAR test exclusion is determined by the SPLSR.

Band	Mode	Position	1g SAR W/kg				Summing result 1g SAR W/kg				
			A	B	C	D	C+D	A+B	A+C	A+D	A+C+D
			Max WWAN	Max WLAN 2.4GHz	Max WLAN 5GHz	BT					
GSM850	Head	Right Cheek	0.61	0.04	0.07	0.01	0.08	0.65	0.68	0.62	0.69
		Right Tilted	0.59	0.04	0.06	0.01	0.07	0.63	0.65	0.60	0.66
		Left Cheek	0.69	0.67	0.21	0.07	0.28	1.36	0.90	0.76	0.97
		Left Tilted	0.67	0.26	0.12	0.02	0.14	0.93	0.79	0.69	0.81
GSM1900	Head	Right Cheek	0.74	0.04	0.07	0.01	0.08	0.78	0.81	0.75	0.82
		Right Tilted	0.93	0.04	0.06	0.01	0.07	0.97	0.99	0.94	1.00
		Left Cheek	0.26	0.67	0.21	0.07	0.28	0.93	0.47	0.33	0.54
		Left Tilted	0.26	0.26	0.12	0.02	0.14	0.52	0.38	0.28	0.40
WCDMA II	Head	Right Cheek	1.06	0.04	0.07	0.01	0.08	1.10	1.13	1.07	1.14
		Right Tilted	1.19	0.04	0.06	0.01	0.07	1.23	1.25	1.20	1.26
		Left Cheek	0.41	0.67	0.21	0.07	0.28	1.08	0.62	0.48	0.69
		Left Tilted	0.37	0.26	0.12	0.02	0.14	0.63	0.49	0.39	0.51
WCDMA IV	Head	Right Cheek	1.09	0.04	0.07	0.01	0.08	1.13	1.16	1.10	1.17
		Right Tilted	1.14	0.04	0.06	0.01	0.07	1.18	1.20	1.15	1.21
		Left Cheek	0.31	0.67	0.21	0.07	0.28	0.98	0.52	0.38	0.59
		Left Tilted	0.37	0.26	0.12	0.02	0.14	0.63	0.49	0.39	0.51
WCDMA V	Head	Right Cheek	0.81	0.04	0.07	0.01	0.08	0.85	0.88	0.82	0.89
		Right Tilted	0.80	0.04	0.06	0.01	0.07	0.84	0.86	0.81	0.87
		Left Cheek	0.88	0.67	0.21	0.07	0.28	1.55	1.09	0.95	1.16
		Left Tilted	0.86	0.26	0.12	0.02	0.14	1.12	0.98	0.88	1.00
LTE 2	Head	Right Cheek	0.71	0.04	0.07	0.01	0.08	0.75	0.78	0.72	0.79
		Right Tilted	0.87	0.04	0.06	0.01	0.07	0.91	0.93	0.88	0.94
		Left Cheek	0.34	0.67	0.21	0.07	0.28	1.01	0.55	0.41	0.62
		Left Tilted	0.34	0.26	0.12	0.02	0.14	0.60	0.46	0.36	0.48
LTE 4	Head	Right Cheek	0.71	0.04	0.07	0.01	0.08	0.75	0.78	0.72	0.79
		Right Tilted	0.95	0.04	0.06	0.01	0.07	0.99	1.01	0.96	1.02
		Left Cheek	0.31	0.67	0.21	0.07	0.28	0.98	0.52	0.38	0.59
		Left Tilted	0.35	0.26	0.12	0.02	0.14	0.61	0.47	0.37	0.49
LTE 5	Head	Right Cheek	0.82	0.04	0.07	0.01	0.08	0.86	0.89	0.83	0.90
		Right Tilted	0.72	0.04	0.06	0.01	0.07	0.76	0.78	0.73	0.79
		Left Cheek	0.70	0.67	0.21	0.07	0.28	1.37	0.91	0.77	0.98
		Left Tilted	0.59	0.26	0.12	0.02	0.14	0.85	0.71	0.61	0.73



# FCC SAR Test Report

Band	Mode	Position	1g SAR W/kg				Summing result 1g SAR W/kg				
			A	B	C	D	C+D	A+B	A+C	A+D	A+C+D
			Max WWAN	Max WLAN 2.4GHz	Max WLAN 5GHz	BT					
LTE 7	Head	Right Cheek	1.01	0.04	0.07	0.01	0.08	1.05	1.08	1.02	1.09
		Right Tilted	0.70	0.04	0.06	0.01	0.07	0.74	0.76	0.71	0.77
		Left Cheek	0.31	0.67	0.21	0.07	0.28	0.98	0.52	0.38	0.59
		Left Tilted	0.26	0.26	0.12	0.02	0.14	0.52	0.38	0.28	0.40
LTE 38	Head	Right Cheek	1.19	0.04	0.07	0.01	0.08	1.23	1.26	1.20	1.27
		Right Tilted	1.09	0.04	0.06	0.01	0.07	1.13	1.15	1.10	1.16
		Left Cheek	0.49	0.67	0.21	0.07	0.28	1.16	0.70	0.56	0.77
		Left Tilted	0.42	0.26	0.12	0.02	0.14	0.68	0.54	0.44	0.56

Band	Mode	Position	1g SAR W/kg				Summing result 1g SAR W/kg				
			A	B	C	D	C+D	A+B	A+C	A+D	A+C+D
			Max WWAN	Max WLAN 2.4GHz	Max WLAN 5GHz	BT					
GSM850	Body-worn	Front Face	0.11	0.16	0.02	0.00	0.02	0.27	0.13	0.11	0.13
		Rear Face	0.13	0.14	0.03	0.00	0.03	0.27	0.16	0.13	0.16
GSM1900	Body-worn	Front Face	0.29	0.16	0.02	0.00	0.02	0.45	0.31	0.29	0.31
		Rear Face	0.49	0.14	0.03	0.00	0.03	0.63	0.52	0.49	0.52
WCDMA II	Body-worn	Front Face	0.78	0.16	0.02	0.00	0.02	0.94	0.80	0.78	0.80
		Rear Face	1.15	0.14	0.03	0.00	0.03	1.29	1.18	1.15	1.18
WCDMA IV	Body-worn	Front Face	0.45	0.16	0.02	0.00	0.02	0.61	0.47	0.45	0.47
		Rear Face	0.72	0.14	0.03	0.00	0.03	0.86	0.75	0.72	0.75
WCDMA V	Body-worn	Front Face	0.13	0.16	0.02	0.00	0.02	0.29	0.15	0.13	0.15
		Rear Face	0.15	0.14	0.03	0.00	0.03	0.29	0.18	0.15	0.18
LTE 2	Body-worn	Front Face	0.67	0.16	0.02	0.00	0.02	0.83	0.69	0.67	0.69
		Rear Face	1.04	0.14	0.03	0.00	0.03	1.18	1.07	1.04	1.07
LTE 4	Body-worn	Front Face	0.51	0.16	0.02	0.00	0.02	0.67	0.53	0.51	0.53
		Rear Face	0.78	0.14	0.03	0.00	0.03	0.92	0.81	0.78	0.81
LTE 5	Body-worn	Front Face	0.11	0.16	0.02	0.00	0.02	0.27	0.13	0.11	0.13
		Rear Face	0.12	0.14	0.03	0.00	0.03	0.26	0.15	0.12	0.15
LTE 7	Body-worn	Front Face	0.65	0.16	0.02	0.00	0.02	0.81	0.67	0.65	0.67
		Rear Face	0.88	0.14	0.03	0.00	0.03	1.02	0.91	0.88	0.91
LTE 38	Body-worn	Front Face	0.34	0.16	0.02	0.00	0.02	0.50	0.36	0.34	0.36
		Rear Face	0.42	0.14	0.03	0.00	0.03	0.56	0.45	0.42	0.45

# FCC SAR Test Report

Band	Mode	Position	1g SAR W/kg				Summing result 1g SAR W/kg				
			A	B	C	D	C+D	A+B	A+C	A+D	A+C+D
			Max WWAN	Max WLAN 2.4GHz	Max WLAN 5GHz	BT					
GSM850	Hotspot	Front Face	0.21	0.10	0.02	0.00	0.02	0.31	0.23	0.21	0.23
		Rear Face	0.27	0.07	0.11	0.00	0.11	0.34	0.38	0.27	0.38
		Left Side	0.14	0.00	0.00	0.00	0.00	0.14	0.14	0.14	0.14
		Right Side	0.08	0.69	0.33	0.01	0.34	0.77	0.41	0.09	0.42
		Top Side	0.19	0.13	0.14	0.00	0.14	0.32	0.33	0.19	0.33
		Bottom Side	0.16	0.00	0.00	0.00	0.00	0.16	0.16	0.16	0.16
GSM1900	Hotspot	Front Face	0.37	0.10	0.02	0.00	0.02	0.47	0.39	0.37	0.39
		Rear Face	0.49	0.07	0.11	0.00	0.11	0.56	0.60	0.49	0.60
		Left Side	0.27	0.00	0.00	0.00	0.00	0.27	0.27	0.27	0.27
		Right Side	0.07	0.69	0.33	0.01	0.34	0.76	0.40	0.08	0.41
		Top Side	0.26	0.13	0.14	0.00	0.14	0.39	0.40	0.26	0.40
		Bottom Side	1.11	0.00	0.00	0.00	0.00	1.11	1.11	1.11	1.11
WCDMA II	Hotspot	Front Face	0.29	0.10	0.02	0.00	0.02	0.39	0.31	0.29	0.31
		Rear Face	0.52	0.07	0.11	0.00	0.11	0.59	0.63	0.52	0.63
		Left Side	0.37	0.00	0.00	0.00	0.00	0.37	0.37	0.37	0.37
		Right Side	0.08	0.69	0.33	0.01	0.34	0.77	0.41	0.09	0.42
		Top Side	0.33	0.13	0.14	0.00	0.14	0.46	0.47	0.33	0.47
		Bottom Side	0.94	0.00	0.00	0.00	0.00	0.94	0.94	0.94	0.94
WCDMA IV	Hotspot	Front Face	0.30	0.10	0.02	0.00	0.02	0.40	0.32	0.30	0.32
		Rear Face	0.45	0.07	0.11	0.00	0.11	0.52	0.56	0.45	0.56
		Left Side	0.21	0.00	0.00	0.00	0.00	0.21	0.21	0.21	0.21
		Right Side	0.05	0.69	0.33	0.01	0.34	0.74	0.38	0.06	0.39
		Top Side	0.36	0.13	0.14	0.00	0.14	0.49	0.50	0.36	0.50
		Bottom Side	0.75	0.00	0.00	0.00	0.00	0.75	0.75	0.75	0.75
WCDMA V	Hotspot	Front Face	0.28	0.10	0.02	0.00	0.02	0.38	0.30	0.28	0.30
		Rear Face	0.32	0.07	0.11	0.00	0.11	0.39	0.43	0.32	0.43
		Left Side	0.22	0.00	0.00	0.00	0.00	0.22	0.22	0.22	0.22
		Right Side	0.09	0.69	0.33	0.01	0.34	0.78	0.42	0.10	0.43
		Top Side	0.30	0.13	0.14	0.00	0.14	0.43	0.44	0.30	0.44
		Bottom Side	0.22	0.00	0.00	0.00	0.00	0.22	0.22	0.22	0.22
LTE 2	Hotspot	Front Face	0.33	0.10	0.02	0.00	0.02	0.43	0.35	0.33	0.35
		Rear Face	0.48	0.07	0.11	0.00	0.11	0.55	0.59	0.48	0.59
		Left Side	0.23	0.00	0.00	0.00	0.00	0.23	0.23	0.23	0.23
		Right Side	0.07	0.69	0.33	0.01	0.34	0.76	0.40	0.08	0.41
		Top Side	0.24	0.13	0.14	0.00	0.14	0.37	0.38	0.24	0.38
		Bottom Side	0.87	0.00	0.00	0.00	0.00	0.87	0.87	0.87	0.87

# FCC SAR Test Report

Band	Mode	Position	1g SAR W/kg				Summing result 1g SAR W/kg				
			A	B	C	D	C+D	A+B	A+C	A+D	A+C+D
			Max WWAN	Max WLAN 2.4GHz	Max WLAN 5GHz	BT					
LTE 4	Hotspot	Front Face	0.33	0.10	0.02	0.00	0.02	0.43	0.35	0.33	0.35
		Rear Face	0.49	0.07	0.11	0.00	0.11	0.56	0.60	0.49	0.60
		Left Side	0.19	0.00	0.00	0.00	0.00	0.19	0.19	0.19	0.19
		Right Side	0.05	0.69	0.33	0.01	0.34	0.74	0.38	0.06	0.39
		Top Side	0.26	0.13	0.14	0.00	0.14	0.39	0.40	0.26	0.40
		Bottom Side	0.87	0.00	0.00	0.00	0.00	0.87	0.87	0.87	0.87
LTE 5	Hotspot	Front Face	0.21	0.10	0.02	0.00	0.02	0.31	0.23	0.21	0.23
		Rear Face	0.23	0.07	0.11	0.00	0.11	0.30	0.34	0.23	0.34
		Left Side	0.12	0.00	0.00	0.00	0.00	0.12	0.12	0.12	0.12
		Right Side	0.16	0.69	0.33	0.01	0.34	0.85	0.49	0.17	0.50
		Top Side	0.21	0.13	0.14	0.00	0.14	0.34	0.35	0.21	0.35
		Bottom Side	0.14	0.00	0.00	0.00	0.00	0.14	0.14	0.14	0.14
LTE 7	Hotspot	Front Face	0.69	0.10	0.02	0.00	0.02	0.79	0.71	0.69	0.71
		Rear Face	0.79	0.07	0.11	0.00	0.11	0.86	0.90	0.79	0.90
		Left Side	0.47	0.00	0.00	0.00	0.00	0.47	0.47	0.47	0.47
		Right Side	0.24	0.69	0.33	0.01	0.34	0.93	0.57	0.25	0.58
		Top Side	0.09	0.13	0.14	0.00	0.14	0.22	0.23	0.09	0.23
		Bottom Side	1.08	0.00	0.00	0.00	0.00	1.08	1.08	1.08	1.08
LTE 38	Hotspot	Front Face	0.54	0.10	0.02	0.00	0.02	0.64	0.56	0.54	0.56
		Rear Face	0.66	0.07	0.11	0.00	0.11	0.73	0.77	0.66	0.77
		Left Side	0.47	0.00	0.00	0.00	0.00	0.47	0.47	0.47	0.47
		Right Side	0.17	0.69	0.33	0.01	0.34	0.86	0.50	0.18	0.51
		Top Side	0.23	0.13	0.14	0.00	0.14	0.36	0.37	0.23	0.37
		Bottom Side	1.01	0.00	0.00	0.00	0.00	1.01	1.01	1.01	1.01

Band	Mode	Position	1g SAR W/kg		Summing result 1g SAR W/kg
			A	B	A+B
			Max WWAN	Max WLAN 5GHz	
GSM1900	Product Specific	Bottom Side	1.76	0.00	1.76
WCDMA II	Product Specific	Rear Face	3.15	0.16	3.31
		Bottom Side	2.40	0.00	2.40
WCDMA IV	Product Specific	Bottom Side	3.11	0.00	3.11
LTE 2	Product Specific	Rear Face	2.30	0.16	2.46
		Bottom Side	1.78	0.00	1.78
LTE 4	Product Specific	Bottom Side	2.89	0.00	2.89
LTE 7	Product Specific	Bottom Side	3.02	0.00	3.02

Test Engineer : Eric Wu, and Willy Chang

**5. Calibration of Test Equipment**

Equipment	Manufacturer	Model	SN	Cal. Date	Cal. Interval
System Validation Dipole	SPEAG	D835V2	4d121	Aug. 23, 2018	1 Year
System Validation Dipole	SPEAG	D1750V2	1055	Aug. 27, 2018	1 Year
System Validation Dipole	SPEAG	D1900V2	5d036	Jan. 25, 2019	1 Year
System Validation Dipole	SPEAG	D2450V2	737	Aug. 24, 2018	1 Year
System Validation Dipole	SPEAG	D2600V2	1020	Aug. 24, 2018	1 Year
System Validation Dipole	SPEAG	D5GHzV2	1019	Mar. 21, 2019	1 Year
Dosimetric E-Field Probe	SPEAG	EX3DV4	3650	May. 20, 2019	1 Year
Dosimetric E-Field Probe	SPEAG	EX3DV4	3971	Mar. 29, 2019	1 Year
Dosimetric E-Field Probe	SPEAG	EX3DV4	7472	Aug. 29, 2018	1 Year
Dosimetric E-Field Probe	SPEAG	EX3DV4	7537	Jun. 18, 2019	1 Year
Data Acquisition Electronics	SPEAG	DAE3	579	Aug. 27, 2018	1 Year
Data Acquisition Electronics	SPEAG	DAE4	1431	Mar. 25, 2019	1 Year
Data Acquisition Electronics	SPEAG	DAE4	861	May. 08, 2019	1 Year
Data Acquisition Electronics	SPEAG	DAE4	1585	Jun. 07, 2019	1 Year
Wireless Communication Test Set	Agilent	E5515C	MY50266628	Dec. 06, 2018	1 Year
Radio Communication Analyzer	Anritsu	MT8820C	6201300638	Jun. 27, 2019	1 Year
Universal Radio Communication Tester	Anritsu	MT8821C	6201502978	Jun. 13, 2019	1 Year
Spectrum Analyzer	R&S	FSL6	102006	Mar. 26, 2019	1 Year
ENA Series Network Analyzer	Agilent	E5071C	MY46214281	Jun. 17, 2019	1 Year
MXG Analog Signal Generator	Agilent	N5181A	MY50143868	Jun. 27, 2019	1 Year
Power Meter	Anritsu	ML2495A	1218009	Jun. 28, 2019	1 Year
Power Sensor	Anritsu	MA2411B	1207252	Jun. 28, 2019	1 Year
Thermometer	YFE	YF-160A	130504591	Mar. 22, 2019	1 Year
Thermometer	YFE	YF-160A	130504591	Mar. 22, 2019	1 Year

## 6. Measurement Uncertainty

According to KDB 865664 D01, SAR measurement uncertainty analysis is required in SAR reports only when the highest measured SAR in a frequency band is  $\geq 1.5$  W/kg for 1-g SAR, and  $\geq 3.75$  W/kg for 10-g SAR. The procedures described in IEEE Std 1528-2013 should be applied. The expanded SAR measurement uncertainty must be  $\leq 30\%$ , for a confidence interval of  $k = 2$ . When the highest measured SAR within a frequency band is  $< 1.5$  W/kg for 1-g and  $< 3.75$  W/kg for 10-g, the extensive SAR measurement uncertainty analysis described in IEEE Std 1528-2013 is not required in SAR reports submitted for equipment approval. Hence, the measurement uncertainty analysis is not required in this SAR report because the test result met the condition.

### **7. Information of the Testing Laboratories**

We, Bureau Veritas Consumer Products Services (H.K.) Ltd., Taoyuan Branch, were founded in 1988 to provide our best service in EMC, Radio, Telecom and Safety consultation. Our laboratories are accredited and approved according to ISO/IEC 17025.

If you have any comments, please feel free to contact us at the following:

**Taiwan HwaYa EMC/RF/Safety Lab:**

Add: No. 19, Hwa Ya 2nd Rd, Wen Hwa Vil., Kwei Shan Hsiang, Taoyuan Hsien 333, Taiwan, R.O.C.

Tel: 886-3-318-3232

Fax: 886-3-327-0892

**Taiwan LinKou EMC/RF Lab:**

Add: No. 47-2, 14th Ling, Chia Pau Vil., Linkou Dist., New Taipei City 244, Taiwan, R.O.C.

Tel: 886-2-2605-2180

Fax: 886-2-2605-1924

**Taiwan HsinChu EMC/RF/Telecom Lab:**

Add: E-2, No.1, Li Hsin 1<sup>st</sup> Road, Hsinchu Science Park, Hsinchu City 30078, Taiwan, R.O.C.

Tel: 886-3-666-8565

Fax: 886-3-666-8323

**Email:** [service.adt@tw.bureauveritas.com](mailto:service.adt@tw.bureauveritas.com)

**Web Site:** [www.bureauveritas-adt.com](http://www.bureauveritas-adt.com)

The road map of all our labs can be found in our web site also.

---END---



## **Appendix A. SAR Plots of System Verification**

The plots for system verification with largest deviation for each SAR system combination are shown as follows.

## System Check\_H835\_190724

**DUT: Dipole 835 MHz; Type: D835V2; SN: 4d121**

Communication System: CW; Frequency: 835 MHz; Duty Cycle: 1:1

Medium: H07T10N1\_0724 Medium parameters used:  $f = 835 \text{ MHz}$ ;  $\sigma = 0.928 \text{ S/m}$ ;  $\epsilon_r = 41.992$ ;  $\rho = 1000 \text{ kg/m}^3$

Ambient Temperature :  $23.8 \text{ }^\circ\text{C}$  ; Liquid Temperature :  $23.3 \text{ }^\circ\text{C}$

DASY5 Configuration:

- Probe: EX3DV4 - SN7537; ConvF(10.48, 10.48, 10.48); Calibrated: 2019/06/18
- Sensor-Surface: 1.4mm (Mechanical Surface Detection)
- Electronics: DAE4 Sn1585; Calibrated: 2019/06/07
- Phantom: SAM Phantom\_1982; Type: QD 000 P41 Ax; Serial: 1982
- Measurement SW: DASY52, Version 52.10 (2); SEMCAD X Version 14.6.12 (7470)

**Pin=250mW/Area Scan (61x61x1):** Interpolated grid:  $dx=1.500 \text{ mm}$ ,  $dy=1.500 \text{ mm}$   
Maximum value of SAR (interpolated) =  $2.98 \text{ W/kg}$

**Pin=250mW/Zoom Scan (5x5x7)/Cube 0:** Measurement grid:  $dx=8\text{mm}$ ,  $dy=8\text{mm}$ ,  $dz=5\text{mm}$   
Reference Value =  $54.09 \text{ V/m}$ ; Power Drift =  $-0.06 \text{ dB}$   
Peak SAR (extrapolated) =  $3.31 \text{ W/kg}$   
**SAR(1 g) =  $2.27 \text{ W/kg}$ ; SAR(10 g) =  $1.5 \text{ W/kg}$**   
Maximum value of SAR (measured) =  $2.98 \text{ W/kg}$

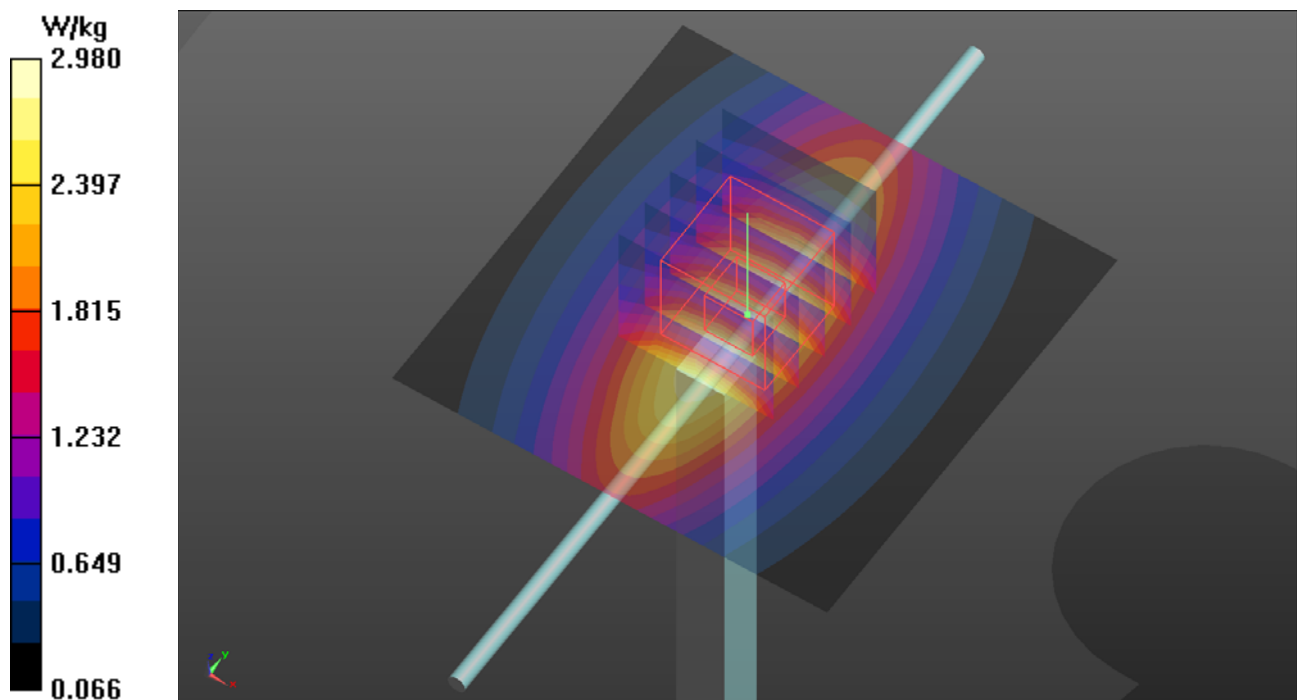



## System Check\_H1750\_190805

**DUT: Dipole 1750 MHz; Type: D1750V2; SN: 1055**

Communication System: CW; Frequency: 1750 MHz; Duty Cycle: 1:1

Medium: H16T20N1\_0805 Medium parameters used:  $f = 1750$  MHz;  $\sigma = 1.32$  S/m;  $\epsilon_r = 39.741$ ;  $\rho = 1000$  kg/m<sup>3</sup>

Ambient Temperature : 23.7 °C ; Liquid Temperature : 23.1 °C

DASY5 Configuration:

- Probe: EX3DV4 - SN7537; ConvF(8.44, 8.44, 8.44); Calibrated: 2019/06/18
- Sensor-Surface: 1.4mm (Mechanical Surface Detection)
- Electronics: DAE4 Sn1585; Calibrated: 2019/06/07
- Phantom: SAM Phantom\_1982; Type: QD 000 P41 Ax; Serial: 1982
- Measurement SW: DASY52, Version 52.10 (2); SEMCAD X Version 14.6.12 (7470)

**Pin=250mW/Area Scan (61x61x1):** Interpolated grid: dx=1.500 mm, dy=1.500 mm  
Maximum value of SAR (interpolated) = 13.8 W/kg

**Pin=250mW/Zoom Scan (5x5x7)/Cube 0:** Measurement grid: dx=8mm, dy=8mm, dz=5mm  
Reference Value = 106.4 V/m; Power Drift = -0.03 dB  
Peak SAR (extrapolated) = 16.3 W/kg  
**SAR(1 g) = 8.92 W/kg; SAR(10 g) = 4.73 W/kg**  
Maximum value of SAR (measured) = 13.8 W/kg

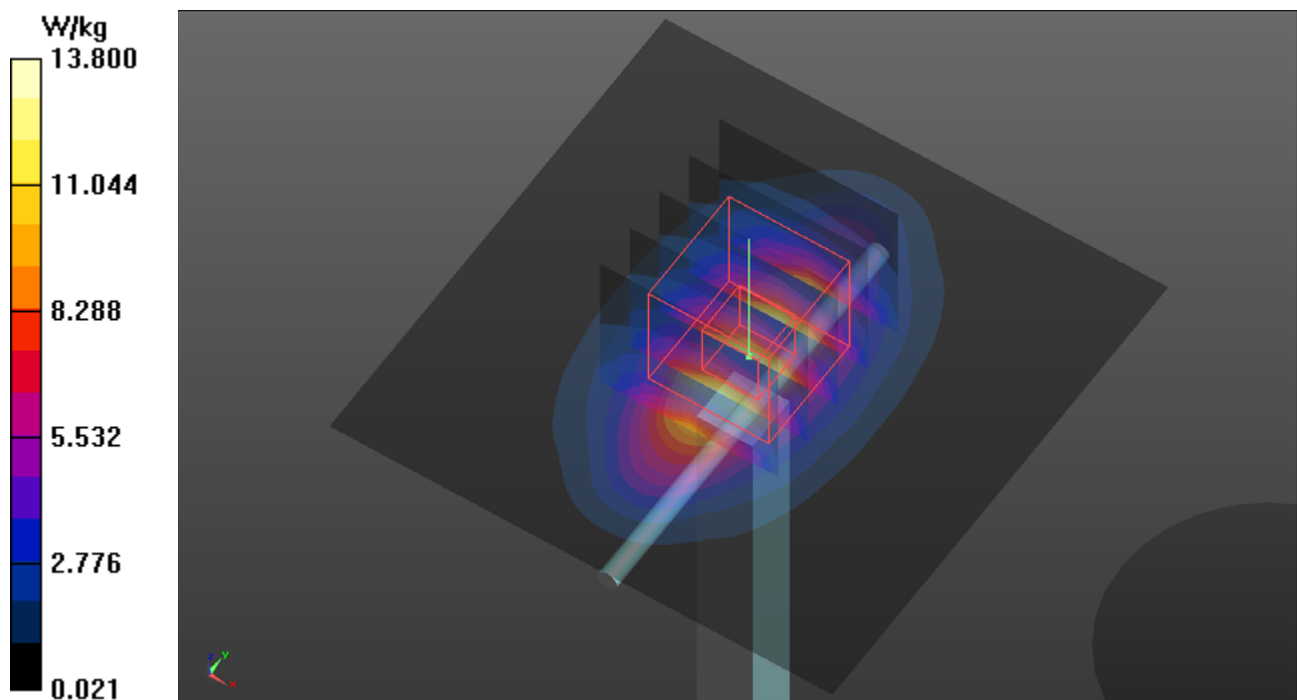

## System Check\_H1900\_190725

**DUT: Dipole 1900 MHz; Type: D1900V2; SN: 5d036**

Communication System: CW; Frequency: 1900 MHz; Duty Cycle: 1:1

Medium: H16T20N1\_0725 Medium parameters used:  $f = 1900$  MHz;  $\sigma = 1.46$  S/m;  $\epsilon_r = 38.759$ ;  $\rho = 1000$  kg/m<sup>3</sup>

Ambient Temperature : 23.6 °C ; Liquid Temperature : 23.3 °C

DASY5 Configuration:

- Probe: EX3DV4 - SN7472; ConvF(8.44, 8.44, 8.44); Calibrated: 2018/08/29
- Sensor-Surface: 1.4mm (Mechanical Surface Detection)
- Electronics: DAE3 Sn579; Calibrated: 2018/08/27
- Phantom: Twin SAM Phantom\_1823; Type: QD000P40CD;
- Measurement SW: DASY52, Version 52.10 (2); SEMCAD X Version 14.6.12 (7470)

**Pin=250mW/Area Scan (61x61x1):** Interpolated grid: dx=1.500 mm, dy=1.500 mm

Maximum value of SAR (interpolated) = 16.3 W/kg

**Pin=250mW/Zoom Scan (5x5x7)/Cube 0:** Measurement grid: dx=8mm, dy=8mm, dz=5mm

Reference Value = 108.9 V/m; Power Drift = -0.07 dB

Peak SAR (extrapolated) = 19.3 W/kg

**SAR(1 g) = 10.3 W/kg; SAR(10 g) = 5.36 W/kg**

Maximum value of SAR (measured) = 16.1 W/kg

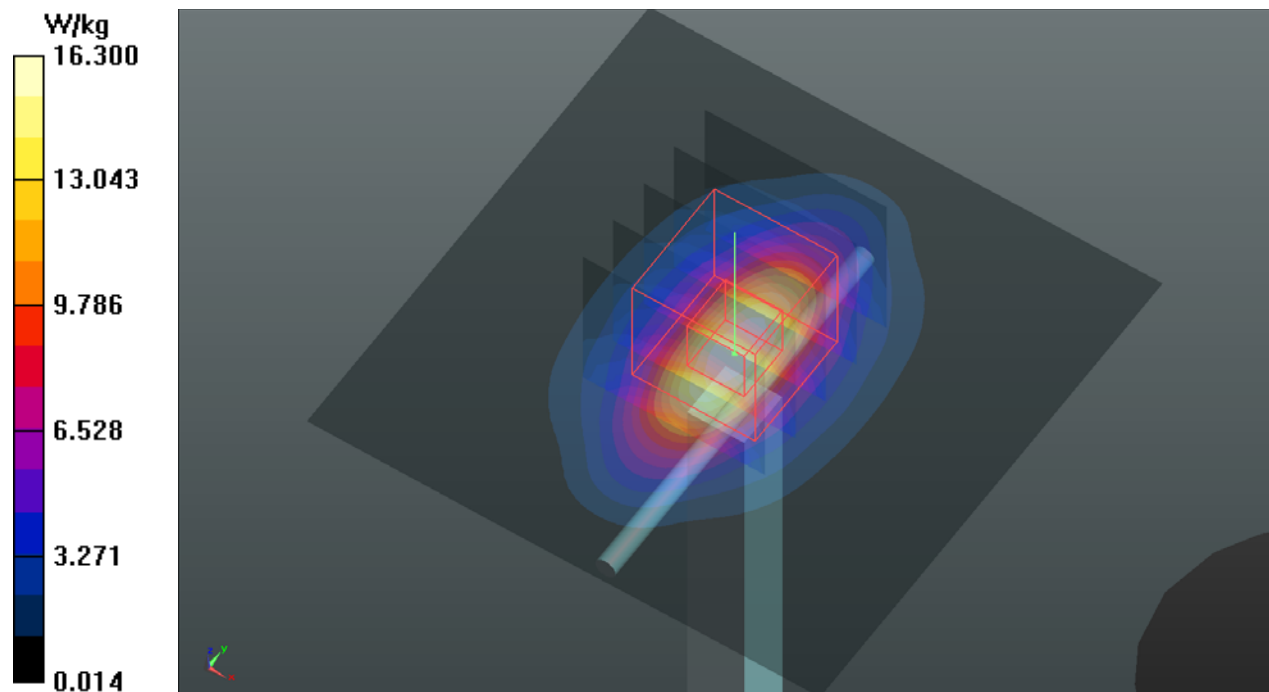

## System Check\_H2450\_190731

**DUT: Dipole 2450 MHz; Type: D2450V2; SN: 737**

Communication System: CW; Frequency: 2450 MHz; Duty Cycle: 1:1

Medium: H19T27N1\_0731 Medium parameters used:  $f = 2450$  MHz;  $\sigma = 1.885$  S/m;  $\epsilon_r = 38.34$ ;  $\rho = 1000$  kg/m<sup>3</sup>

Ambient Temperature : 23.8 °C ; Liquid Temperature : 23.1 °C

DASY5 Configuration:

- Probe: EX3DV4 - SN7472; ConvF(7.71, 7.71, 7.71); Calibrated: 2018/08/29
- Sensor-Surface: 1.4mm (Mechanical Surface Detection)
- Electronics: DAE3 Sn579; Calibrated: 2018/08/27
- Phantom: Twin SAM Phantom\_1823; Type: QD000P40CD;
- Measurement SW: DASY52, Version 52.10 (2); SEMCAD X Version 14.6.12 (7470)

**Pin=250mW/Area Scan (81x81x1):** Interpolated grid: dx=1.200 mm, dy=1.200 mm

Maximum value of SAR (interpolated) = 22.4 W/kg

**Pin=250mW/Zoom Scan (7x7x7)/Cube 0:** Measurement grid: dx=5mm, dy=5mm, dz=5mm

Reference Value = 111.7 V/m; Power Drift = -0.10 dB

Peak SAR (extrapolated) = 27.5 W/kg

**SAR(1 g) = 13.5 W/kg; SAR(10 g) = 6.29 W/kg**

Maximum value of SAR (measured) = 22.5 W/kg

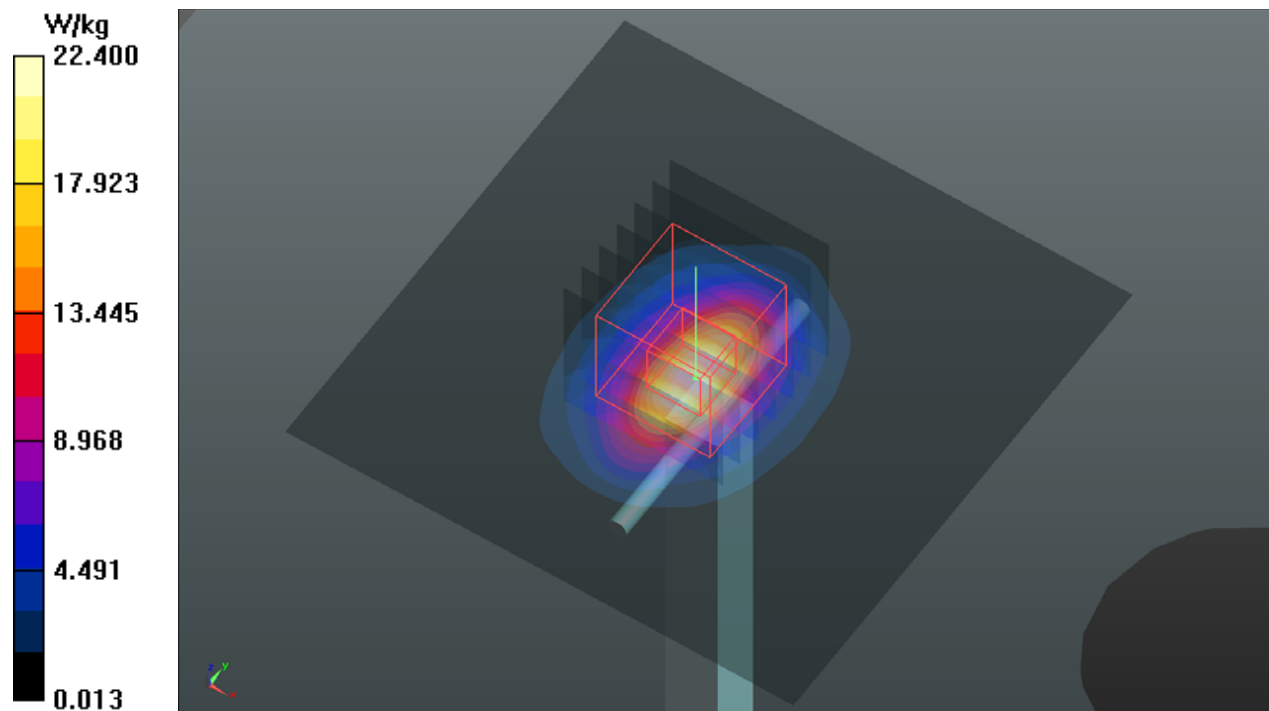

## System Check\_H2600\_190731

**DUT: Dipole 2600 MHz; Type: D2600V2; SN: 1020**

Communication System: CW; Frequency: 2600 MHz; Duty Cycle: 1:1

Medium: H19T27N1\_0731 Medium parameters used:  $f = 2600$  MHz;  $\sigma = 2.045$  S/m;  $\epsilon_r = 37.845$ ;  $\rho = 1000$  kg/m<sup>3</sup>

Ambient Temperature : 23.8 °C ; Liquid Temperature : 23.1 °C

DASY5 Configuration:

- Probe: EX3DV4 - SN7472; ConvF(7.53, 7.53, 7.53); Calibrated: 2018/08/29
- Sensor-Surface: 1.4mm (Mechanical Surface Detection)
- Electronics: DAE3 Sn579; Calibrated: 2018/08/27
- Phantom: Twin SAM Phantom\_1823; Type: QD000P40CD;
- Measurement SW: DASY52, Version 52.10 (2); SEMCAD X Version 14.6.12 (7470)

**Pin=250mW/Area Scan (81x81x1):** Interpolated grid: dx=1.200 mm, dy=1.200 mm

Maximum value of SAR (interpolated) = 26.2 W/kg

**Pin=250mW/Zoom Scan (7x7x7)/Cube 0:** Measurement grid: dx=5mm, dy=5mm, dz=5mm

Reference Value = 117.2 V/m; Power Drift = -0.08 dB

Peak SAR (extrapolated) = 33.7 W/kg

**SAR(1 g) = 14.9 W/kg; SAR(10 g) = 6.59 W/kg**

Maximum value of SAR (measured) = 26.4 W/kg

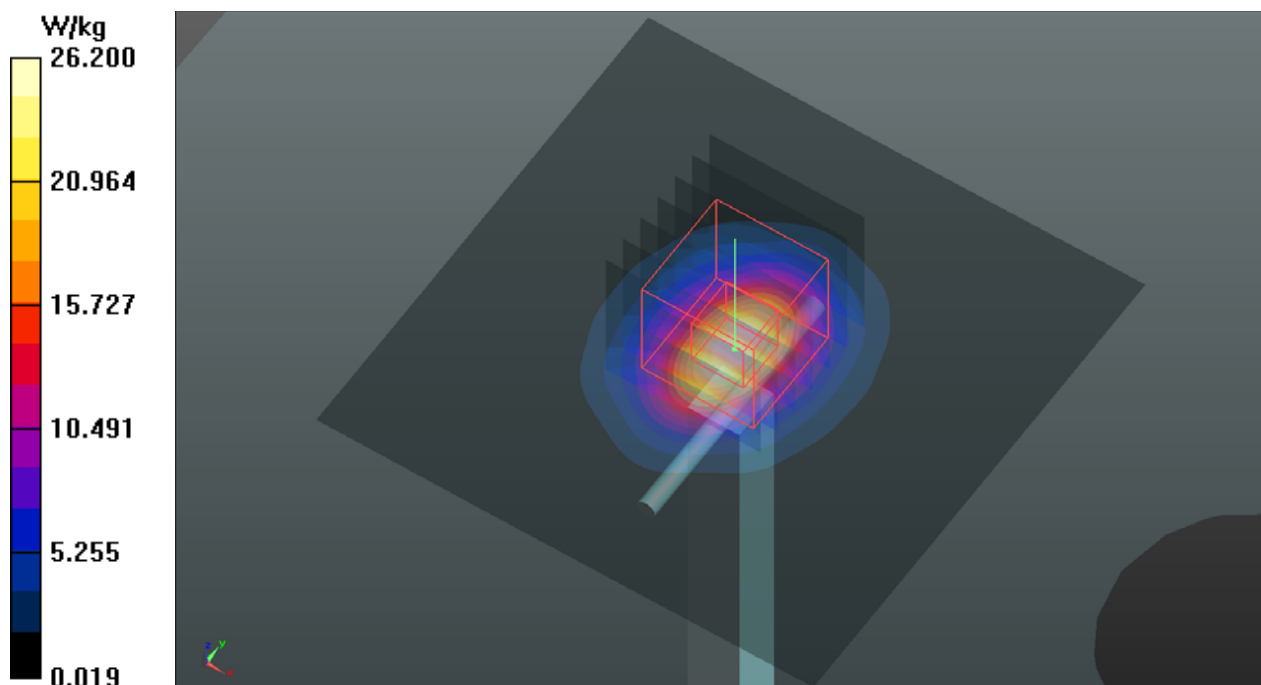

## System Check\_H5250\_190727

**DUT: Dipole 5 GHz; Type: D5GHzV2; SN: 1019**

Communication System: CW; Frequency: 5250 MHz; Duty Cycle: 1:1

Medium: H34T60N2\_0727 Medium parameters used:  $f = 5250$  MHz;  $\sigma = 4.665$  S/m;  $\epsilon_r = 36.681$ ;  $\rho = 1000$  kg/m<sup>3</sup>

Ambient Temperature : 23.8 °C ; Liquid Temperature : 23.5 °C

DASY5 Configuration:

- Probe: EX3DV4 - SN3650; ConvF(5.4, 5.4, 5.4); Calibrated: 2019/05/20
- Sensor-Surface: 1.4mm (Mechanical Surface Detection)
- Electronics: DAE4 Sn861; Calibrated: 2019/05/08
- Phantom: Twin SAM Phantom\_1653; Type: QD000P40;
- Measurement SW: DASY52, Version 52.10 (2); SEMCAD X Version 14.6.12 (7470)

**Pin=100mW/Area Scan (91x91x1):** Interpolated grid: dx=1.000 mm, dy=1.000 mm

Maximum value of SAR (interpolated) = 17.4 W/kg

**Pin=100mW/Zoom Scan (7x7x12)/Cube 0:** Measurement grid: dx=4mm, dy=4mm, dz=2mm

Reference Value = 66.48 V/m; Power Drift = 0.11 dB

Peak SAR (extrapolated) = 30.7 W/kg

**SAR(1 g) = 7.59 W/kg; SAR(10 g) = 2.19 W/kg**

Maximum value of SAR (measured) = 19.1 W/kg

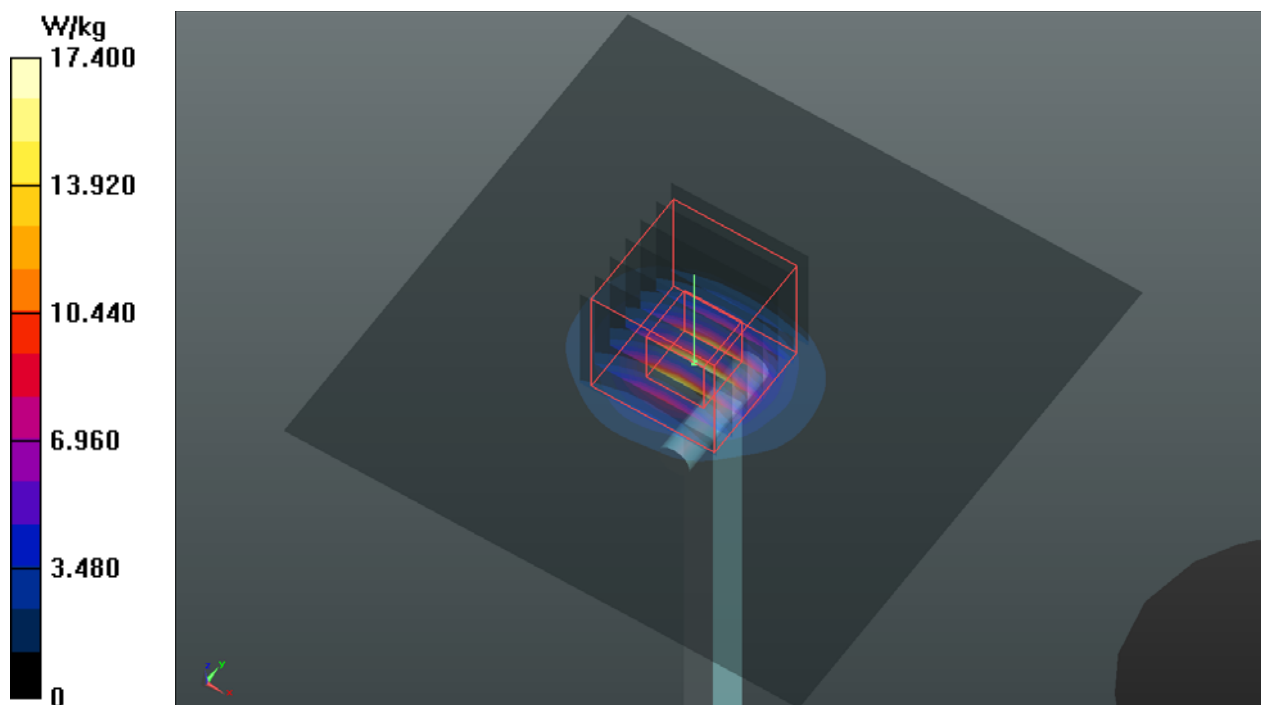

## System Check\_H5600\_190807

**DUT: Dipole 5 GHz; Type: D5GHzV2; SN: 1019**

Communication System: CW; Frequency: 5600 MHz; Duty Cycle: 1:1

Medium: H34T60N2\_0807 Medium parameters used:  $f = 5600$  MHz;  $\sigma = 5.178$  S/m;  $\epsilon_r = 34.66$ ;  $\rho = 1000$  kg/m<sup>3</sup>

Ambient Temperature : 23.8 °C ; Liquid Temperature : 23.3 °C

DASY5 Configuration:

- Probe: EX3DV4 - SN3971; ConvF(4.78, 4.78, 4.78); Calibrated: 2019/03/29
- Sensor-Surface: 1.4mm (Mechanical Surface Detection)
- Electronics: DAE4 Sn1431; Calibrated: 2019/03/25
- Phantom: Twin SAM Phantom\_1496; Type: QD000P40CB;
- Measurement SW: DASY52, Version 52.10 (2); SEMCAD X Version 14.6.12 (7470)

**Pin=100mW/Area Scan (91x91x1):** Interpolated grid: dx=1.000 mm, dy=1.000 mm  
Maximum value of SAR (interpolated) = 22.3 W/kg

**Pin=100mW/Zoom Scan (7x7x12)/Cube 0:** Measurement grid: dx=4mm, dy=4mm, dz=2mm  
Reference Value = 74.38 V/m; Power Drift = -0.14 dB  
Peak SAR (extrapolated) = 42.1 W/kg  
**SAR(1 g) = 9.1 W/kg; SAR(10 g) = 2.6 W/kg**  
Maximum value of SAR (measured) = 23.7 W/kg

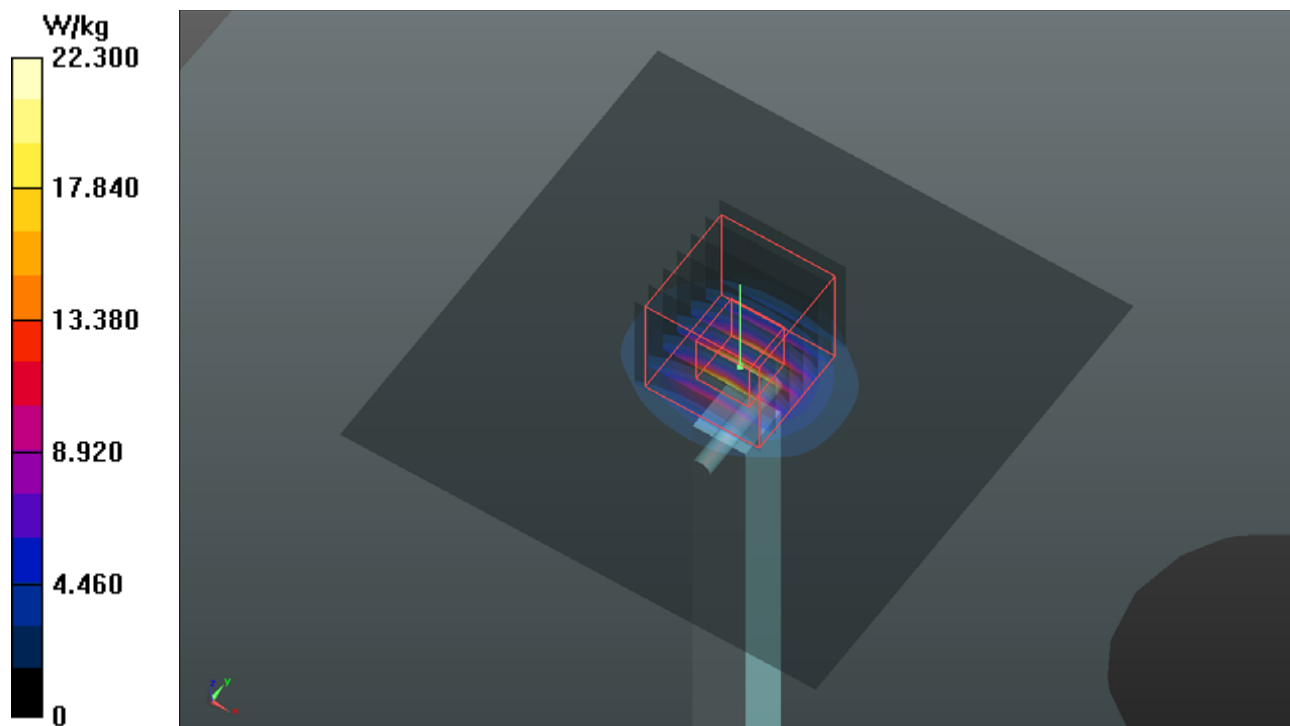

## System Check\_H5750\_190727

**DUT: Dipole 5 GHz; Type: D5GHzV2; SN: 1019**

Communication System: CW; Frequency: 5750 MHz; Duty Cycle: 1:1

Medium: H34T60N2\_0727 Medium parameters used:  $f = 5750$  MHz;  $\sigma = 5.084$  S/m;  $\epsilon_r = 36.412$ ;  $\rho = 1000$  kg/m<sup>3</sup>

Ambient Temperature : 23.8 °C ; Liquid Temperature : 23.5 °C

DASY5 Configuration:

- Probe: EX3DV4 - SN3650; ConvF(5.17, 5.17, 5.17); Calibrated: 2019/05/20
- Sensor-Surface: 1.4mm (Mechanical Surface Detection)
- Electronics: DAE4 Sn861; Calibrated: 2019/05/08
- Phantom: Twin SAM Phantom\_1653; Type: QD000P40CD;
- Measurement SW: DASY52, Version 52.10 (2); SEMCAD X Version 14.6.12 (7470)

**Pin=100mW/Area Scan (91x91x1):** Interpolated grid: dx=1.000 mm, dy=1.000 mm  
Maximum value of SAR (interpolated) = 20.5 W/kg

**Pin=100mW/Zoom Scan (7x7x12)/Cube 0:** Measurement grid: dx=4mm, dy=4mm, dz=2mm  
Reference Value = 72.68 V/m; Power Drift = 0.06 dB  
Peak SAR (extrapolated) = 37.9 W/kg  
**SAR(1 g) = 8.37 W/kg; SAR(10 g) = 2.4 W/kg**  
Maximum value of SAR (measured) = 22.1 W/kg

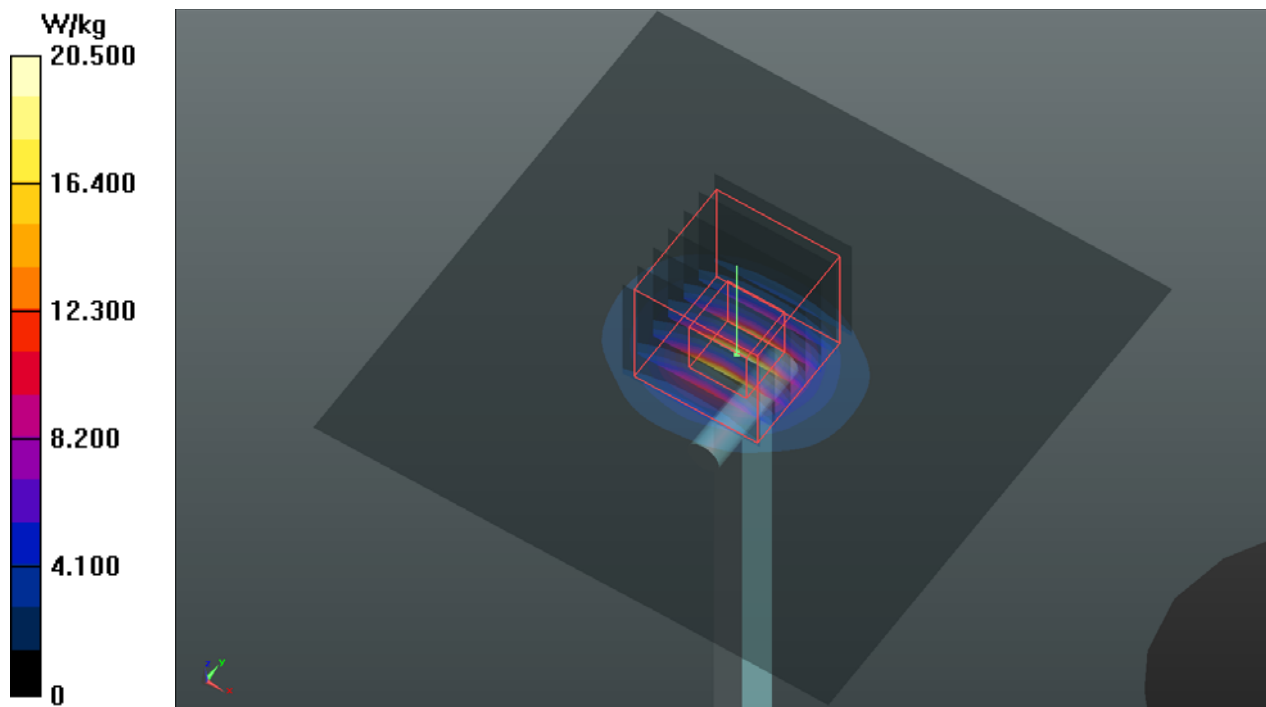

## System Check\_H1750\_190808

**DUT: Dipole 1750 MHz; Type: D1750V2; SN: 1055**

Communication System: CW; Frequency: 1750 MHz; Duty Cycle: 1:1

Medium: H16T20N1\_0808 Medium parameters used:  $f = 1750$  MHz;  $\sigma = 1.333$  S/m;  $\epsilon_r = 39.672$ ;  $\rho = 1000$  kg/m<sup>3</sup>

Ambient Temperature : 23.8 °C ; Liquid Temperature : 23.3 °C

DASY5 Configuration:

- Probe: EX3DV4 - SN3971; ConvF(8.8, 8.8, 8.8); Calibrated: 2019/03/29
- Sensor-Surface: 1.4mm (Mechanical Surface Detection)
- Electronics: DAE4 Sn1431; Calibrated: 2019/03/25
- Phantom: Twin SAM Phantom\_1496; Type: QD000P40CB;
- Measurement SW: DASY52, Version 52.10 (2); SEMCAD X Version 14.6.12 (7470)

**Pin=250mW/Area Scan (61x61x1):** Interpolated grid: dx=1.500 mm, dy=1.500 mm  
Maximum value of SAR (interpolated) = 14.7 W/kg

**Pin=250mW/Zoom Scan (5x5x7)/Cube 0:** Measurement grid: dx=8mm, dy=8mm, dz=5mm  
Reference Value = 107.9 V/m; Power Drift = -0.03 dB  
Peak SAR (extrapolated) = 17.5 W/kg  
**SAR(1 g) = 9.39 W/kg; SAR(10 g) = 4.97 W/kg**  
Maximum value of SAR (measured) = 14.6 W/kg

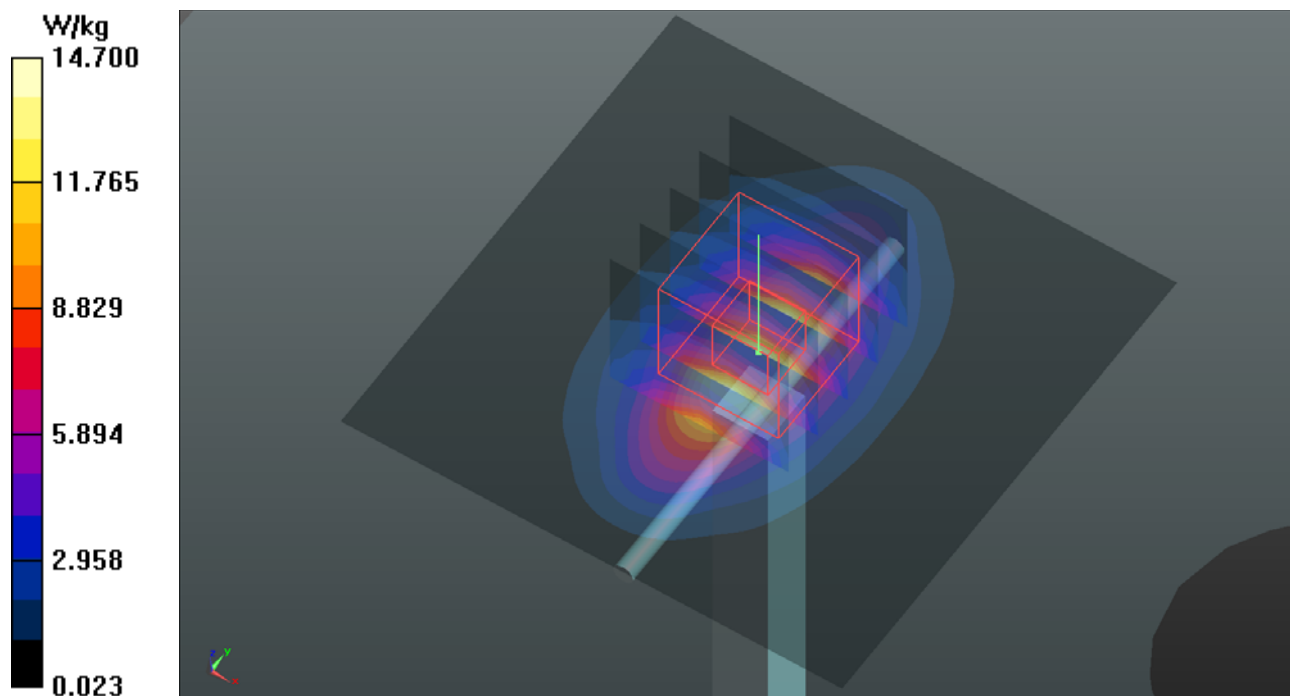



## System Check\_H1900\_190808

**DUT: Dipole 1900 MHz; Type: D1900V2; SN: 5d036**

Communication System: CW; Frequency: 1900 MHz; Duty Cycle: 1:1

Medium: H16T20N1\_0808 Medium parameters used:  $f = 1900$  MHz;  $\sigma = 1.461$  S/m;  $\epsilon_r = 39.134$ ;  $\rho = 1000$  kg/m<sup>3</sup>

Ambient Temperature : 23.8 °C ; Liquid Temperature : 23.3 °C

DASY5 Configuration:

- Probe: EX3DV4 - SN3971; ConvF(8.47, 8.47, 8.47); Calibrated: 2019/03/29
- Sensor-Surface: 1.4mm (Mechanical Surface Detection)
- Electronics: DAE4 Sn1431; Calibrated: 2019/03/25
- Phantom: Twin SAM Phantom\_1496; Type: QD000P40CB;
- Measurement SW: DASY52, Version 52.10 (2); SEMCAD X Version 14.6.12 (7470)

**Pin=250mW/Area Scan (61x61x1):** Interpolated grid: dx=1.500 mm, dy=1.500 mm

Maximum value of SAR (interpolated) = 15.7 W/kg

**Pin=250mW/Zoom Scan (5x5x7)/Cube 0:** Measurement grid: dx=8mm, dy=8mm, dz=5mm

Reference Value = 97.82 V/m; Power Drift = 0.18 dB

Peak SAR (extrapolated) = 19.0 W/kg

**SAR(1 g) = 10.1 W/kg; SAR(10 g) = 5.27 W/kg**

Maximum value of SAR (measured) = 15.8 W/kg

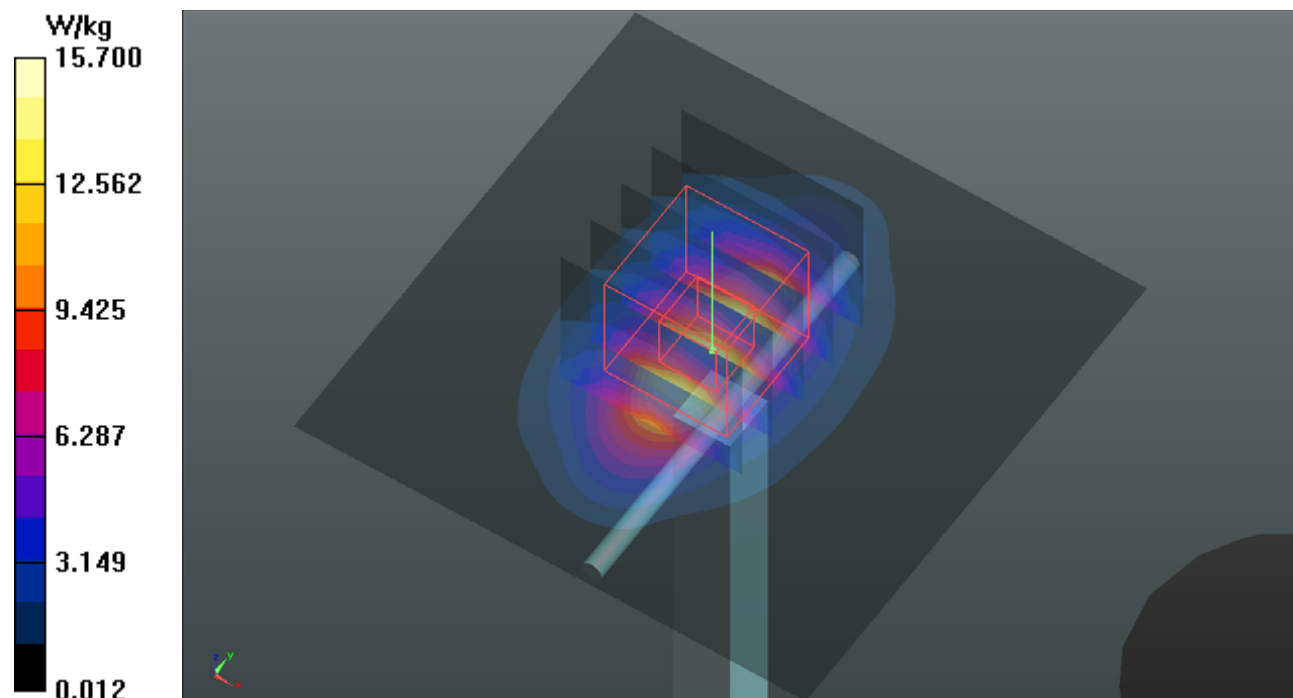

## System Check\_H2600\_190808

**DUT: Dipole 2600 MHz; Type: D2600V2; SN: 1020**

Communication System: CW; Frequency: 2600 MHz; Duty Cycle: 1:1

Medium: H19T27N1\_0808 Medium parameters used:  $f = 2600$  MHz;  $\sigma = 2.039$  S/m;  $\epsilon_r = 38.539$ ;  $\rho = 1000$  kg/m<sup>3</sup>

Ambient Temperature : 23.7 °C ; Liquid Temperature : 23.1 °C

DASY5 Configuration:

- Probe: EX3DV4 - SN3971; ConvF(7.48, 7.48, 7.48); Calibrated: 2019/03/29
- Sensor-Surface: 1.4mm (Mechanical Surface Detection)
- Electronics: DAE4 Sn1431; Calibrated: 2019/03/25
- Phantom: Twin SAM Phantom\_1496; Type: QD000P40CB;
- Measurement SW: DASY52, Version 52.10 (2); SEMCAD X Version 14.6.12 (7470)

**Pin=250mW/Area Scan (81x81x1):** Interpolated grid: dx=1.200 mm, dy=1.200 mm  
Maximum value of SAR (interpolated) = 23.5 W/kg

**Pin=250mW/Zoom Scan (7x7x7)/Cube 0:** Measurement grid: dx=5mm, dy=5mm, dz=5mm  
Reference Value = 103.0 V/m; Power Drift = -0.01 dB  
Peak SAR (extrapolated) = 29.6 W/kg  
**SAR(1 g) = 13.5 W/kg; SAR(10 g) = 6.08 W/kg**  
Maximum value of SAR (measured) = 23.5 W/kg

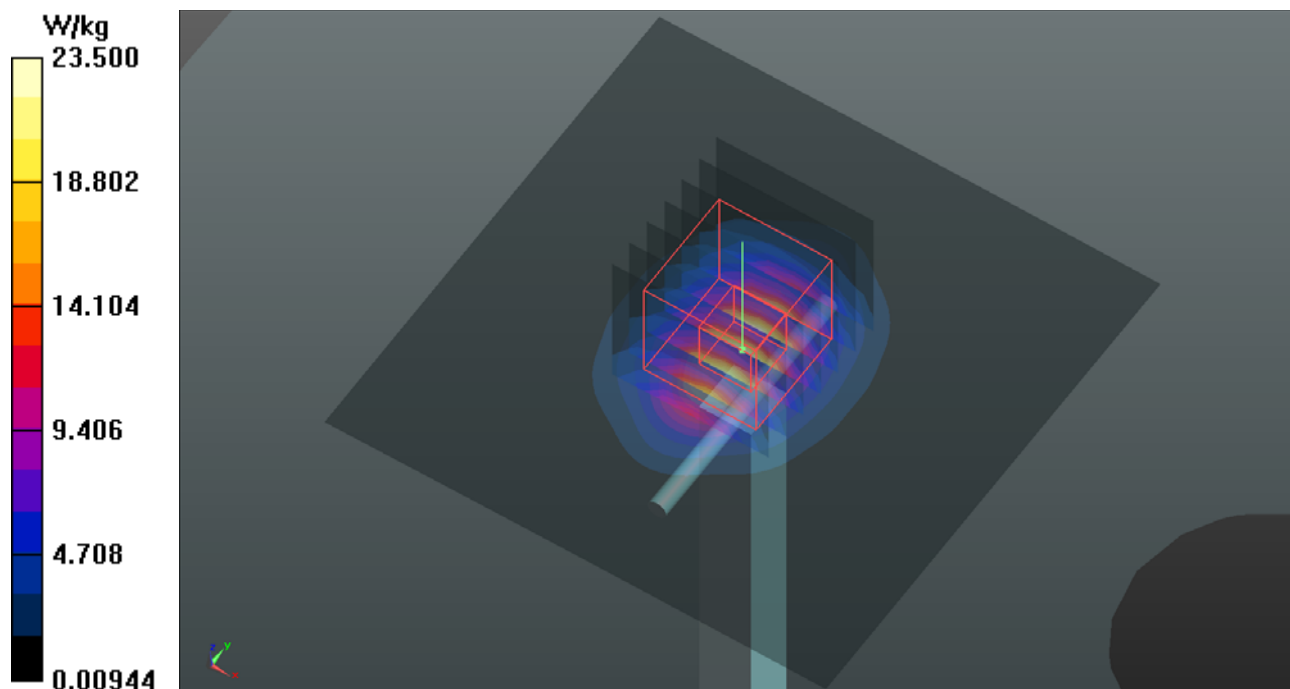

## System Check\_H5250\_190727

**DUT: Dipole 5 GHz; Type: D5GHzV2; SN: 1019**

Communication System: CW; Frequency: 5250 MHz; Duty Cycle: 1:1

Medium: H34T60N2\_0727 Medium parameters used:  $f = 5250$  MHz;  $\sigma = 4.665$  S/m;  $\epsilon_r = 36.681$ ;  $\rho = 1000$  kg/m<sup>3</sup>

Ambient Temperature : 23.8 °C ; Liquid Temperature : 23.5 °C

DASY5 Configuration:

- Probe: EX3DV4 - SN3650; ConvF(5.4, 5.4, 5.4); Calibrated: 2019/05/20
- Sensor-Surface: 1.4mm (Mechanical Surface Detection)
- Electronics: DAE4 Sn861; Calibrated: 2019/05/08
- Phantom: Twin SAM Phantom\_1653; Type: QD000P40;
- Measurement SW: DASY52, Version 52.10 (2); SEMCAD X Version 14.6.12 (7470)

**Pin=100mW/Area Scan (91x91x1):** Interpolated grid: dx=1.000 mm, dy=1.000 mm

Maximum value of SAR (interpolated) = 17.4 W/kg

**Pin=100mW/Zoom Scan (7x7x12)/Cube 0:** Measurement grid: dx=4mm, dy=4mm, dz=2mm

Reference Value = 66.48 V/m; Power Drift = 0.11 dB

Peak SAR (extrapolated) = 30.7 W/kg

**SAR(1 g) = 7.59 W/kg; SAR(10 g) = 2.19 W/kg**

Maximum value of SAR (measured) = 19.1 W/kg

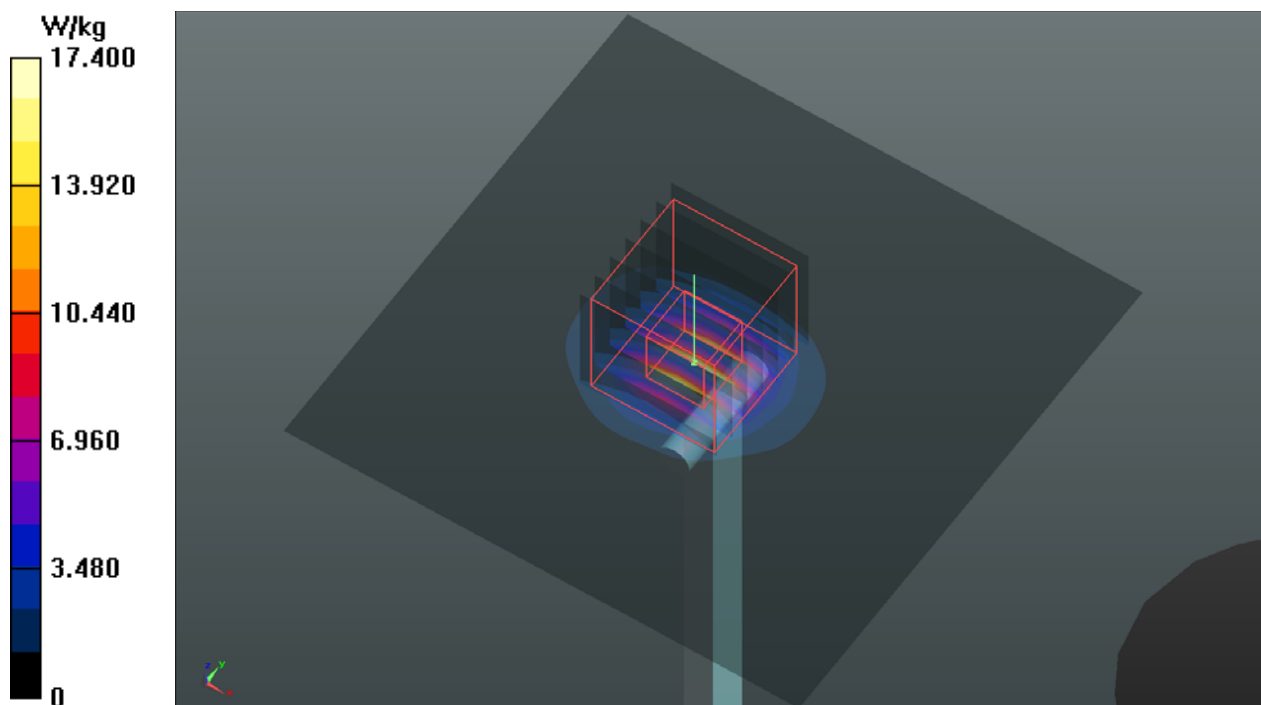

## System Check\_H5600\_190807

**DUT: Dipole 5 GHz; Type: D5GHzV2; SN: 1019**

Communication System: CW; Frequency: 5600 MHz; Duty Cycle: 1:1

Medium: H34T60N2\_0807 Medium parameters used:  $f = 5600$  MHz;  $\sigma = 5.178$  S/m;  $\epsilon_r = 34.66$ ;  $\rho = 1000$  kg/m<sup>3</sup>

Ambient Temperature : 23.8 °C ; Liquid Temperature : 23.3 °C

DASY5 Configuration:

- Probe: EX3DV4 - SN3971; ConvF(4.78, 4.78, 4.78); Calibrated: 2019/03/29
- Sensor-Surface: 1.4mm (Mechanical Surface Detection)
- Electronics: DAE4 Sn1431; Calibrated: 2019/03/25
- Phantom: Twin SAM Phantom\_1496; Type: QD000P40CB;
- Measurement SW: DASY52, Version 52.10 (2); SEMCAD X Version 14.6.12 (7470)

**Pin=100mW/Area Scan (91x91x1):** Interpolated grid: dx=1.000 mm, dy=1.000 mm  
Maximum value of SAR (interpolated) = 22.3 W/kg

**Pin=100mW/Zoom Scan (7x7x12)/Cube 0:** Measurement grid: dx=4mm, dy=4mm, dz=2mm  
Reference Value = 74.38 V/m; Power Drift = -0.14 dB  
Peak SAR (extrapolated) = 42.1 W/kg  
**SAR(1 g) = 9.1 W/kg; SAR(10 g) = 2.6 W/kg**  
Maximum value of SAR (measured) = 23.7 W/kg

