

FCC TEST REPORT

(Part 15, Subpart E)

Applicant:	Xiaomi Communications Co., Ltd.
Address:	The Rainbow City of China Resources, NO.68, Qinghe Middle Street, Haidian District, Beijing, China

Manufacturer or Supplier:	Xiaomi Communications Co., Ltd.
Address:	The Rainbow City of China Resources, NO.68, Qinghe Middle Street, Haidian District, Beijing, China
Product:	Mobile Phone
Brand Name:	XIAOMI
Model Name:	M1904F3BG
FCC ID:	2AFZZF3BG
Date of tests:	Jul. 15, 2019 ~ Aug. 4, 2019

The tests have been carried out according to the requirements of the following standard:

FCC Part 15, Subpart E, Section 15.407

CONCLUSION: The submitted sample was found to COMPLY with the test requirement

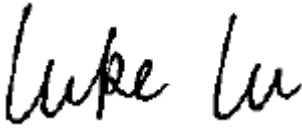
Prepared by Alex Chen Engineer / Mobile Department	Approved by Luke Lu Manager / Mobile Department
 Date: Aug. 6, 2019	 Date: Aug. 6, 2019

This report is governed by, and incorporates by reference, CPS Conditions of Service as posted at the date of issuance of this report at <http://www.bureauveritas.com/home/about-us/our-business/cps/about-us/terms-conditions/> and is intended for your exclusive use. Any copying or replication of this report to or for any other person or entity, or use of our name or trademark, is permitted only with our prior written permission. This report sets forth our findings solely with respect to the test samples identified herein. The results set forth in this report are not indicative or representative of the quality or characteristics of the lot from which a test sample was taken or any similar or identical product unless specifically and expressly noted. Our report includes all of the tests requested by you and the results thereof based upon the information that you provided to us. Measurement uncertainty is only provided upon request for accredited tests. You have 60 days from date of issuance of this report to notify us of any material error or omission caused by our negligence or if you require measurement uncertainty; provided, however, that such notice shall be in writing and shall specifically address the issue you wish to raise. A failure to raise such issue within the prescribed time shall constitute you unqualified acceptance of the completeness of this report, the tests conducted and the correctness of the report contents.



TABLE OF CONTENTS

RELEASE CONTROL RECORD	4
1 SUMMARY OF TEST RESULTS	5
1.1 MEASUREMENT UNCERTAINTY	5
2 GENERAL INFORMATION.....	6
2.1 GENERAL DESCRIPTION OF EUT	6
2.2 DESCRIPTION OF TEST MODES	8
2.2.1 TEST MODE APPLICABILITY AND TESTED CHANNEL DETAIL.....	10
2.3 DUTY CYCLE OF TEST SIGNAL	15
2.4 DESCRIPTION OF SUPPORT UNITS	16
2.4.1 CONFIGURATION OF SYSTEM UNDER TEST	17
2.5 GENERAL DESCRIPTION OF APPLIED STANDARDS	17
3 TEST TYPES AND RESULTS.....	18
3.1 RADIATED EMISSION AND BANDEDGE MEASUREMENT.....	18
3.1.1 LIMITS OF RADIATED EMISSION AND BANDEDGE MEASUREMENT.....	18
3.1.2 LIMITS OF UNWANTED EMISSION.....	18
3.1.3 TEST INSTRUMENTS.....	19
3.1.4 TEST PROCEDURES	20
3.1.5 DEVIATION FROM TEST STANDARD	20
3.1.6 TEST SETUP	21
3.1.7 EUT OPERATING CONDITION	22
3.1.8 TEST RESULTS	23
3.2 CONDUCTED EMISSION MEASUREMENT	71
3.2.1 LIMITS OF CONDUCTED EMISSION MEASUREMENT	71
3.2.2 TEST INSTRUMENTS.....	71
3.2.3 TEST PROCEDURES	71
3.2.4 DEVIATION FROM TEST STANDARD	72
3.2.5 TEST SETUP	72
3.2.6 EUT OPERATING CONDITIONS	72
3.2.7 TEST RESULTS	73
3.3 MAXIMUM CONDUCTED OUTPUT POWER MEASUREMENT	75
3.3.1 LIMITS OF MAXIMUM CONDUCTED OUTPUT POWER MEASUREMENT	75
3.3.2 TEST SETUP	76
3.3.3 TEST INSTRUMENTS.....	76



3.3.4	TEST PROCEDURE	77
3.3.5	DEVIATION FROM TEST STANDARD	79
3.3.6	EUT OPERATING CONDITIONS	79
3.3.7	TEST RESULTS	80
3.4	MAXIMUM POWER SPECTRAL DENSITY MEASUREMENT.....	94
3.4.1	LIMITS OF MAXIMUM POWER SPECTRAL DENSITY MEASUREMENT	94
3.4.2	TEST SETUP	94
3.4.3	TEST INSTRUMENTS.....	94
3.4.4	TEST PROCEDURES	95
3.4.5	DEVIATION FROM TEST STANDARD	95
3.4.6	EUT OPERATING CONDITIONS	95
3.4.7	TEST RESULTS	96
4	PHOTOGRAPHS OF THE TEST CONFIGURATION	103
5	APPENDIX A – MODIFICATIONS RECORDERS FOR ENGINEERING CHANGES TO THE EUT BY THE LAB	104



BUREAU
VERITAS

Test Report No.: RF190712W002

RELEASE CONTROL RECORD

ISSUE NO.	REASON FOR CHANGE	DATE ISSUED
RF190712W002	Original release	Aug. 6, 2019



1 SUMMARY OF TEST RESULTS

The EUT has been tested according to the following specifications:

APPLIED STANDARD: FCC PART 15, SUBPART E			
STANDARD SECTION	TEST TYPE AND LIMIT	RESULT	REMARK
15.407(b)(6)	AC Power Conducted Emission	PASS	Meet the requirement of limit. Minimum passing margin is -18.67dB at 0.540000MHz.
15.407(b) (1/2/3/4/5)	Radiated Emission & Band Edge Measurement	PASS	Meet the requirement of limit. Minimum passing margin is -4.16dB at 5150MHz.
15.407(a/1/2/3)	Maximum conducted output Power	PASS	Meet the requirement of limit.
15.407(a/1/2/3)	Peak Power Spectral Density	PASS	Meet the requirement of limit.
15.403(i)	26 dB Bandwidth	PASS	Meet the requirement of limit. (for U-NII-1/2A/2C Band)
15.407(e)	6 dB Bandwidth	PASS	Meet the requirement of limit. (U-NII-3 Band only)
15.203	Antenna Requirement	PASS	No antenna connector is used.

1.1 MEASUREMENT UNCERTAINTY

Where relevant, the following measurement uncertainty levels have been estimated for tests performed on the EUT as specified in CISPR 16-4-2:

MEASUREMENT	UNCERTAINTY
AC Power Conducted emissions	±2.70dB
Radiated emissions (30MHz~1GMHz)	±4.98dB
Radiated emissions (1GMHz ~6GMHz)	±4.70dB
Radiated emissions (6GMHz ~18GMHz)	±4.60dB
Radiated emissions (18GMHz ~40GMHz)	±4.12dB
Conducted emissions	±4.01dB
Occupied Channel Bandwidth	±43.58KHz
Conducted Output power	±2.06dB
Power Spectral Density	±0.85 dB

This uncertainty represents an expanded uncertainty expressed at approximately the 95% confidence level using a coverage factor of $k = 2$.



2 GENERAL INFORMATION

2.1 GENERAL DESCRIPTION OF EUT

PRODUCT	Mobile Phone
BRAND NAME	XIAOMI
MODEL NAME	M1904F3BG
NOMINAL VOLTAGE	5.0V/9.0V/12.0Vdc (adapter or host equipment) 3.85Vdc (Li-ion, battery)
MODULATION	OFDM
TRANSFER RATE	802.11a: 54.0/ 48.0/ 36.0/ 24.0/ 18.0/ 12.0/ 9.0/ 6.0Mbps 802.11n: up to MCS7 802.11ac: up to 390.0Mbps
OPERATING FREQUENCY	5180 ~ 5240MHz, 5260 ~ 5320MHz, 5500 ~ 5700MHz, 5745 ~ 5805MHz
NUMBER OF CHANNEL	5180 ~ 5240MHz: 4 for 802.11a, 802.11n (20MHz) 2 for 802.11n (40MHz) 1 for 802.11ac (80MHz) 5260 ~ 5320MHz: 4 for 802.11a, 802.11n (20MHz) 2 for 802.11n (40MHz) 1 for 802.11ac (80MHz) 5500 ~ 5700MHz: 11 for 802.11a, 802.11n (20MHz) 5 for 802.11n (40MHz) 2 for 802.11ac (80MHz) 5745 ~ 5805MHz: 4 for 802.11a, 802.11n (20MHz) 2 for 802.11n (40MHz) 1 for 802.11ac (80MHz)
AVERAGE POWER	51.68mW for 5180 ~ 5240MHz 54.61mW for 5260 ~ 5320MHz 65.96mW for 5500 ~ 5700MHz 56.79mW for 5745 ~ 5805MHz
ANTENNA TYPE	5180 ~ 5240MHz: PIFA Antenna with 1.84dBi gain 5260 ~ 5320MHz: PIFA Antenna with 1.47dBi gain 5500 ~ 5700MHz: PIFA Antenna with 0.28dBi gain 5745 ~ 5805MHz: PIFA Antenna with 1.55dBi gain
HW VERSION	P1
SW VERSION	MIUI 10
I/O PORTS	Refer to user's manual



NOTE:

1. For a more detailed features description, please refer to the manufacturer’s specifications or the user's manual.
2. The EUT incorporates a SISO function. Physically, the EUT provides one completed transmitter and one receiver.

MODULATION MODE	TX FUNCTION
802.11a	1TX/1RX
802.11n (20MHz)	1TX/1RX
802.11n (40MHz)	1TX/1RX
802.11ac (80MHz)	1TX/1RX

3. For the test results, the EUT had been tested with all conditions. But only the worst case was shown in test report.
4. List of Accessory:

ACCESSORIES	BRAND	MODEL	MANUFACTURER	SPECIFICATION
Battery	MI	BM4F	Sunwoda Electronic Co., Ltd	Rating: 3.85Vdc, 4030mAh
AC Adapter	MI	MDY-10-ED	Jiansu Chenyang Electron Co., Ltd	I/P:100-240Vac, 0.5A O/P: 5Vdc, 3A 9Vdc, 2A/ 12Vdc, 1.5A
USB Cable 1	MI	K23312	Suzhou Keli Science&Technology Development Co., Ltd	1.0m non-shielded cable, with w/o ferrite core
Earphone	MI	EM023	One More Acoustics Technology Co., Ltd	1.25m non-shielded cable, with w/o ferrite core



2.2 DESCRIPTION OF TEST MODES

FOR 5150 ~ 5250MHz

4 channels are provided for 802.11a, 802.11n (20MHz):

CHANNEL	FREQUENCY	CHANNEL	FREQUENCY
36	5180 MHz	44	5220 MHz
40	5200 MHz	48	5240 MHz

2 channels are provided for 802.11n (40MHz):

CHANNEL	FREQUENCY	CHANNEL	FREQUENCY
38	5190 MHz	46	5230 MHz

1 channel is provided for 802.11ac (80MHz):

CHANNEL	FREQUENCY	CHANNEL	FREQUENCY
42	5210 MHz		

FOR 5250 ~ 5350MHz

4 channels are provided for 802.11a, 802.11n (20MHz):

CHANNEL	FREQUENCY	CHANNEL	FREQUENCY
52	5260 MHz	60	5300 MHz
56	5280 MHz	64	5320 MHz

2 channels are provided for 802.11n (40MHz):

CHANNEL	FREQUENCY	CHANNEL	FREQUENCY
54	5270 MHz	62	5310 MHz

1 channel is provided for 802.11ac (80MHz):

CHANNEL	FREQUENCY	CHANNEL	FREQUENCY
58	5290 MHz		



FOR 5470 ~ 5725MHz

11 channels are provided for 802.11a, 802.11n (20MHz):

CHANNEL	FREQUENCY	CHANNEL	FREQUENCY
100	5500 MHz	124	5620 MHz
104	5520 MHz	128	5640 MHz
108	5540 MHz	132	5660 MHz
112	5560 MHz	136	5680 MHz
116	5580 MHz	140	5700 MHz
120	5600 MHz		

5 channels are provided for 802.11n (40MHz):

CHANNEL	FREQUENCY	CHANNEL	FREQUENCY
102	5510 MHz	126	5630 MHz
110	5550 MHz	134	5670 MHz
118	5590 MHz		

2 channel is provided for 802.11ac (80MHz):

CHANNEL	FREQUENCY	CHANNEL	FREQUENCY
106	5530 MHz	122	5610 MHz

FOR 5725 ~ 5850MHz

4 channels are provided for 802.11a, 802.11n (20MHz):

CHANNEL	FREQUENCY	CHANNEL	FREQUENCY
153	5765 MHz	157	5785 MHz
149	5745 MHz	161	5805 MHz

2 channels are provided for 802.11n (40MHz):

CHANNEL	FREQUENCY	CHANNEL	FREQUENCY
151	5755 MHz	159	5795 MHz

1 channel is provided for 802.11ac (80MHz):

CHANNEL	FREQUENCY	CHANNEL	FREQUENCY
155	5775 MHz		



2.2.1 TEST MODE APPLICABILITY AND TESTED CHANNEL DETAIL

EUT CONFIGURE MODE	APPLICABLE TO				DESCRIPTION
	RE≥1G	RE<1G	PLC	APCM	
A	√	√	√	-	Powered by Adapter with wifi(5G) link
B	-	-	-	√	Powered by Battery with wifi(5G) link
C	-	-	-	-	Powered by USB with wifi(5G) link

Where

RE≥1G: Radiated Emission above 1GHz

RE<1G: Radiated Emission below 1GHz

PLC: Power Line Conducted Emission

APCM: Antenna Port Conducted Measurement

NOTE:

The EUT had been pre-tested on the positioned of each 3 axis. The worst case was found when positioned on **X-plane**.

NOTE: "-" means no effect.



RADIATED EMISSION TEST (ABOVE 1GHz):

Pre-Scan has been conducted to determine the worst-case mode from all possible combinations between available modulations, data rates and antenna ports (if EUT with antenna diversity architecture).

Following channel(s) was (were) selected for the final test as listed below.

EUT CONFIGURE MODE	MODE	FREQ. BAND (MHz)	AVAILABLE CHANNEL	TESTED CHANNEL	MODULATION	DATA RATE (Mbps)
A	802.11a	5180-5240	36 to 48	36, 40, 48	OFDM	6.0
A	802.11n (20MHz)		36 to 48	36, 40, 48	OFDM	MCS0
A	802.11n (40MHz)		38 to 46	38, 46	OFDM	MCS0
A	802.11ac (80MHz)		42	42	OFDM	MCS0
A	802.11a	5260-5320	52 to 64	52, 60, 64	OFDM	6.0
A	802.11n (20MHz)		52 to 64	52, 60, 64	OFDM	MCS0
A	802.11n (40MHz)		54 to 62	54, 62	OFDM	MCS0
A	802.11ac (80MHz)		58	58	OFDM	MCS0
A	802.11a	5500-5700	100 to 144	100, 116, 140	OFDM	6.0
A	802.11n (20MHz)		100 to 140	100, 116, 140	OFDM	MCS0
A	802.11n (40MHz)		102 to 134	102, 110, 134	OFDM	MCS0
A	802.11ac (80MHz)		106	106	OFDM	MCS0
A	802.11a	5745-5805	149 to 161	149, 157, 161	OFDM	6.0
A	802.11n (20MHz)		149 to 161	149, 157, 161	OFDM	MCS0
A	802.11n (40MHz)		151 to 159	151, 159	OFDM	MCS0
A	802.11ac (80MHz)		155	155	OFDM	MCS0



RADIATED EMISSION TEST (BELOW 1GHz):

- Pre-Scan has been conducted to determine the worst-case mode from all possible combinations between available modulations, data rates and antenna ports (if EUT with antenna diversity architecture).
- Following channel(s) was (were) selected for the final test as listed below.

EUT CONFIGURE MODE	MODE	FREQ. BAND (MHz)	AVAILABLE CHANNEL	TESTED CHANNEL	MODULATION	DATA RATE (Mbps)
A	802.11n40	5180-5240	38 to 46	38	OFDM	MCS0

POWER LINE CONDUCTED EMISSION TEST:

- Pre-Scan has been conducted to determine the worst-case mode from all possible combinations between available modulations, data rates and antenna ports (if EUT with antenna diversity architecture).
- Following channel(s) was (were) selected for the final test as listed below.

EUT CONFIGURE MODE	MODE	FREQ. BAND (MHz)	AVAILABLE CHANNEL	TESTED CHANNEL	MODULATION	DATA RATE (Mbps)
A	802.11n40	5180-5240	38 to 46	38	OFDM	MCS0



BANDEDGE MEASUREMENT:

- Pre-Scan has been conducted to determine the worst-case mode from all possible combinations between available modulations, data rates and antenna ports (if EUT with antenna diversity architecture).
- Following channel(s) was (were) selected for the final test as listed below.

EUT CONFIGURE MODE	MODE	FREQ. BAND (MHz)	AVAILABLE CHANNEL	TESTED CHANNEL	MODULATION	DATA RATE (Mbps)
A	802.11a	5180-5240	36 to 48	36, 48	OFDM	6.0
A	802.11n (20MHz)		36 to 48	36, 48	OFDM	MCS0
A	802.11n (40MHz)		38 to 46	38, 46	OFDM	MCS0
A	802.11ac (80MHz)		42	42	OFDM	MCS0
A	802.11a	5260-5320	52 to 64	52, 64	OFDM	6.0
A	802.11n (20MHz)		52 to 64	52, 64	OFDM	MCS0
A	802.11n (40MHz)		54 to 62	54, 62	OFDM	MCS0
A	802.11ac (80MHz)		58	58	OFDM	MCS0
A	802.11a	5500-5700	100 to 140	100, 140	OFDM	6.0
A	802.11n (20MHz)		100 to 140	100, 140	OFDM	MCS0
A	802.11n (40MHz)		102 to 134	102, 134	OFDM	MCS0
A	802.11ac (80MHz)		106	106	OFDM	MCS0
A	802.11a	5745-5805	149 to 161	149, 161	OFDM	6.0
A	802.11n (20MHz)		149 to 161	149, 161	OFDM	MCS0
A	802.11n (40MHz)		151 to 159	151, 159	OFDM	MCS0
A	802.11ac (80MHz)		155	155	OFDM	MCS0

**ANTENNA PORT CONDUCTED MEASUREMENT:**

- This item includes all test value of each mode, but only includes spectrum plot of worst value of each mode.
- Pre-Scan has been conducted to determine the worst-case mode from all possible combinations between available modulations, data rates and antenna ports (if EUT with antenna diversity architecture).
- Following channel(s) was (were) selected for the final test as listed below.

EUT CONFIGURE MODE	MODE	FREQ. BAND (MHz)	AVAILABLE CHANNEL	TESTED CHANNEL	MODULATION TECHNOLOGY	DATA RATE (Mbps)
B	802.11a	5180-5240	36 to 48	36, 40, 48	OFDM	6.0
B	802.11n (20MHz)		36 to 48	36, 40, 48	OFDM	MCS0
B	802.11n (40MHz)		38 to 46	38, 46	OFDM	MCS0
B	802.11ac (80MHz)		42	42	OFDM	MCS0
B	802.11a	5260-5320	52 to 64	52, 60, 64	OFDM	6.0
B	802.11n (20MHz)		52 to 64	52, 60, 64	OFDM	MCS0
B	802.11n (40MHz)		54 to 62	54, 62	OFDM	MCS0
B	802.11ac (80MHz)		58	58	OFDM	MCS0
B	802.11a	5500-5700	100 to 140	100, 116, 140	OFDM	6.0
B	802.11n (20MHz)		100 to 140	100, 116, 140	OFDM	MCS0
B	802.11n (40MHz)		102 to 134	102, 110, 134	OFDM	MCS0
B	802.11ac (80MHz)		106	106	OFDM	MCS0
B	802.11a	5745-5805	149 to 161	149, 157,161	OFDM	6.0
B	802.11n (20MHz)		149 to 161	149, 157,161	OFDM	MCS0
B	802.11n (40MHz)		151 to 159	151, 159	OFDM	MCS0
B	802.11ac (80MHz)		155	155	OFDM	MCS0

TEST CONDITION:

APPLICABLE TO	ENVIRONMENTAL CONDITIONS	INPUT POWER	TESTED BY
RE<1G	23deg. C, 70%RH	DC 5/9/12V By Adapter	Star Le
RE≥1G	23deg. C, 70%RH	DC 5/9/12V By Adapter	Star Le
PLC	25deg. C, 52%RH	DC 5/9/12V By Adapter	Jacky Liu
APCM	25deg. C, 60%RH	DC 3.85V from battery	Walker Ye



2.3 DUTY CYCLE OF TEST SIGNAL

Duty cycle of test signal is < 98%, duty factor shall be considered.

802.11a: Duty cycle = 2.061/2.120 = 0.972, Duty factor = 10 * log(1/0.972) = 0.12

802.11n (20MHz): Duty cycle = 1.922/1.962 = 0.980, duty factor shall not be considered.

802.11n (40MHz): Duty cycle = 942/989 = 0.952, Duty factor = 10 * log(1/0.952) = 0.21

802.11ac (80MHz): Duty cycle = 460/506 = 0.909, Duty factor = 10 * log(1/0.909) = 0.41

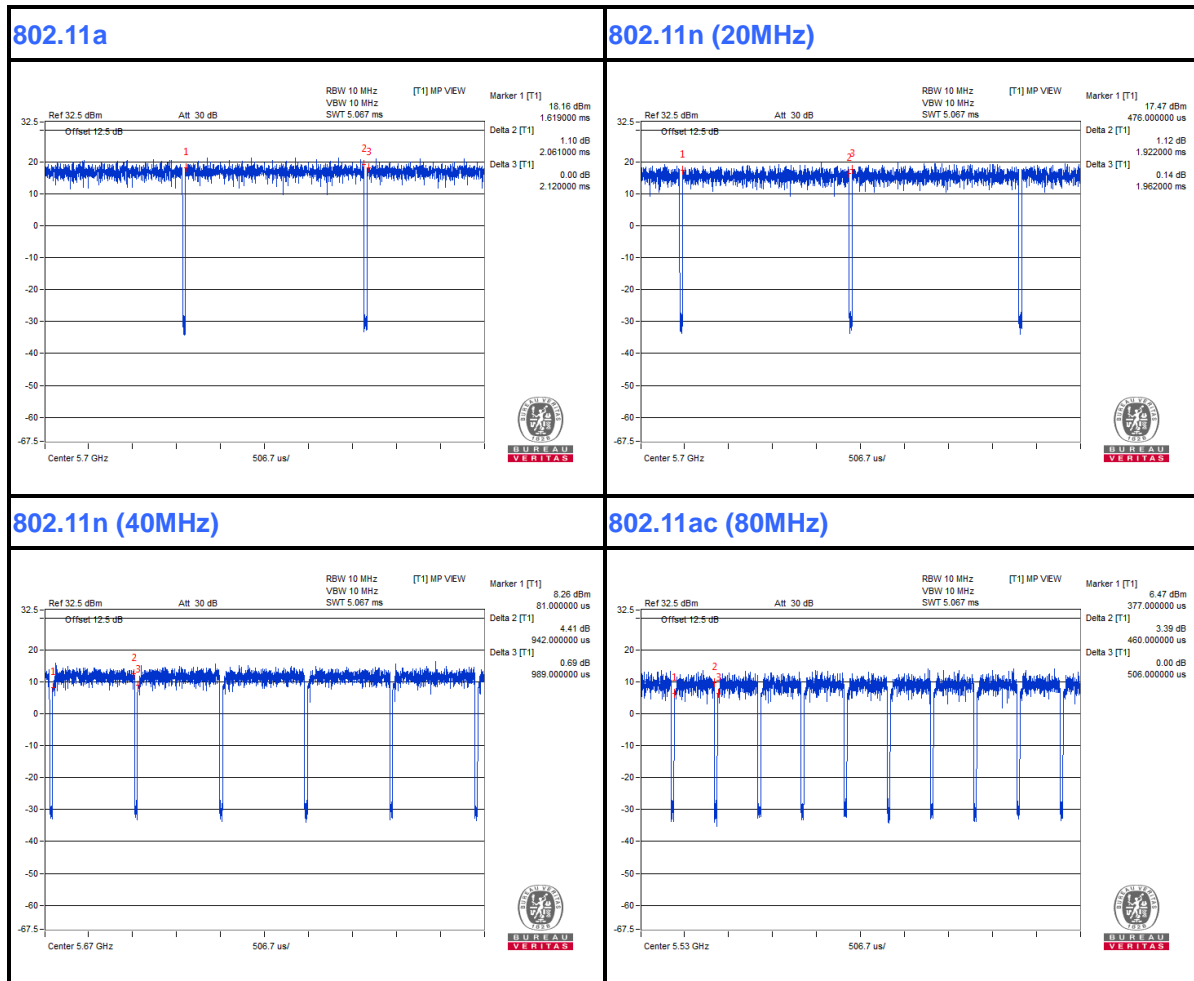



2.4 DESCRIPTION OF SUPPORT UNITS

The EUT has been tested as an independent unit together with other necessary accessories or support units. The following support units or accessories were used to form a representative test configuration during the tests.

NO.	PRODUCT	BRAND	MODEL NO.	SERIAL NO.	FCC ID
1	N/A	N/A	N/A	N/A	N/A

NO.	SIGNAL CABLE DESCRIPTION OF THE ABOVE SUPPORT UNITS
1	N/A



2.4.1 CONFIGURATION OF SYSTEM UNDER TEST

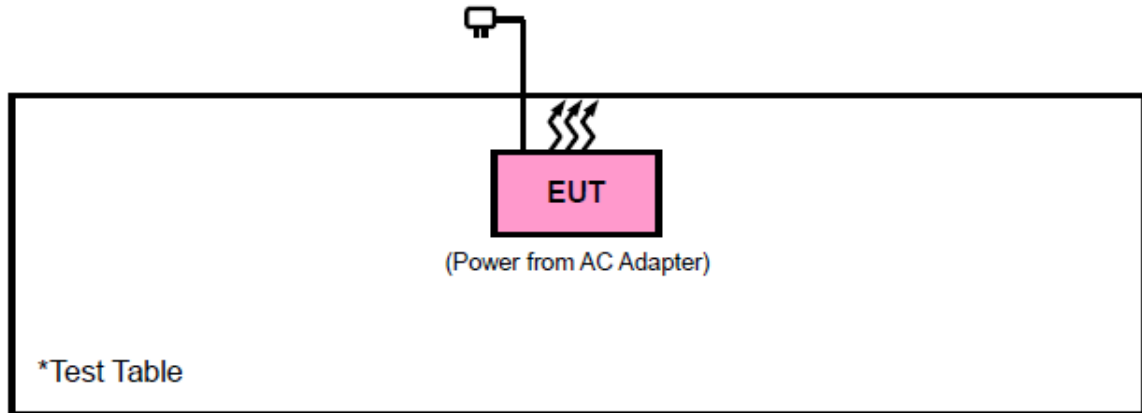

2.5 GENERAL DESCRIPTION OF APPLIED STANDARDS

The EUT is a RF Product. According to the specifications of the manufacturer, it must comply with the requirements of the following standards:

FCC Part 15, Subpart E (15.407)

KDB 789033 D02 General U-NII Test Procedures New Rules v02r01

ANSI C63.10-2013

All test items have been performed and recorded as per the above standards.

NOTE: The EUT is also considered as a kind of computer peripheral, because the connection to computer is necessary for typical use. It has been verified to comply with the requirements of FCC Part 15, Subpart B, Class B (Certification). The test report has been issued separately.



3 TEST TYPES AND RESULTS

3.1 RADIATED EMISSION AND BANDEGE MEASUREMENT

3.1.1 LIMITS OF RADIATED EMISSION AND BANDEGE MEASUREMENT

Radiated emissions which fall in the restricted bands must comply with the radiated emission limits specified as below table:

FREQUENCIES (MHz)	FIELD STRENGTH (microvolts/meter)	MEASUREMENT DISTANCE (meters)
0.009 ~ 0.490	2400/F(kHz)	300
0.490 ~ 1.705	24000/F(kHz)	30
1.705 ~ 30.0	30	30
30 ~ 88	100	3
88 ~ 216	150	3
216 ~ 960	200	3
Above 960	500	3

NOTE:

1. The lower limit shall apply at the transition frequencies.
2. Emission level (dBuV/m) = 20 log Emission level (uV/m).
3. For frequencies above 1000MHz, the field strength limits are based on average detector, however, the peak field strength of any emission shall not exceed the maximum permitted average limits, specified above by more than 20dB under any condition of modulation.

3.1.2 LIMITS OF UNWANTED EMISSION

RESTRICTED BANDS	APPLICABLE TO	LIMIT	
	789033 D02 General UNII Test Procedures New Rules v02r01	FIELD STRENGTH AT 3m (dBµV/m)	
		PK : 74	AV : 54
OUT OF THE RESTRICTED BANDS	APPLICABLE TO	EIRP LIMIT (dBm/MHz)	EQUIVALENT FIELD STRENGTH AT 3m (dBµV/m)
	15.407(b)(1)	PK : -27	PK : 68.3
	15.407(b)(2)		
	15.407(b)(3)		
15.407(b)(4)	See note 2 (FCC 16-24)		



NOTE: The following formula is used to convert the equipment isotropic radiated power (eirp) to field strength:

$$E = \frac{1000000}{3} \sqrt{30 P} \quad \mu\text{V/m, where P is the eirp (Watts).}$$

2. All emissions shall be limited to a level of -27 dBm/MHz at 75 MHz or more above or below the band edge increasing linearly to 10 dBm/MHz at 25 MHz above or below the band edge, and from 25 MHz above or below the band edge increasing linearly to a level of 15.6 dBm/MHz at 5 MHz above or below the band edge, and from 5 MHz above or below the band edge increasing linearly to a level of 27 dBm/MHz at the band edge.

3.1.3 TEST INSTRUMENTS

Equipment	Manufacturer	Model No.	Serial No.	Last Cal.	Next Cal.
3m Semi-anechoic Chamber	ETS-LINDGREN	9m*6m*6m	Euroshieldpn-CT0001143-1216	Feb. 26,19	Feb. 25,20
Bilog Antenna	ETS-LINDGREN	3143B	00161965	Feb. 26,19	Feb. 25,20
Horn Antenna	ETS-LINDGREN	3117	00168728	Feb. 26,19	Feb. 25,20
Horn Antenna (18GHz-40GHz)	N/A	QWH-SL-18-40-K-SG/QMS-00361	15433	Nov. 21, 18	Nov. 20, 19
Test Software	E3	V 9.160323	N/A	N/A	N/A
Test Software	ADT	ADT_Radiated_V7.6.15.9.2	N/A	N/A	N/A
10dB Attenuator	JFW/USA	50HF-010-SMA	1505	Jun. 24,19	Jun. 23,20
MXE EMI Receiver	KEYSIGHT	N9038A-544	MY54450026	Feb. 26,19	Feb. 25,20
Signal Pre-Amplifier	EMSI	EMC 9135	980249	Jun. 24,19	Jun. 23,20
Signal Pre-Amplifier	EMSI	EMC 012645B	980257	Jun. 24,19	Jun. 23,20
Signal Pre-Amplifier	EMSI	EMC 184045B	980259	Jun. 24,19	Jun. 23,20

NOTE:

1. The calibration interval of the above test instruments is 12 months and the calibrations are traceable to CEPREI/CHINA, GRGT/CHINA and NIM/CHINA.
2. The test was performed in 3m Chamber.
3. The FCC Site Registration No. is 525120; The Designation No. is CN1171.



3.1.4 TEST PROCEDURES

- a. The EUT was placed on the top of a rotating table 0.8 meters (for below 1GHz) / 1.5 meters (for above 1GHz) above the ground at 3 meter chamber room for test. The table was rotated 360 degrees to determine the position of the highest radiation.
- b. The EUT was set 3 meters away from the interference-receiving antenna, which was mounted on the top of a variable-height antenna tower.
- c. The antenna is a broadband antenna, and its height is varied from one meter to four meters above the ground to determine the maximum value of the field strength. Both horizontal and vertical polarizations of the antenna are set to make the measurement.
- d. For each suspected emission, the EUT was arranged to its worst case and then the antenna was tuned to heights from 1 meter to 4 meters and the rotatable table was turned from 0 degrees to 360 degrees to find the maximum reading.
- e. The test-receiver system was set to Peak Detect Function and Specified Bandwidth with Maximum Hold Mode.
- f. If the emission level of the EUT in peak mode was 10dB lower than the limit specified, then testing could be stopped and the peak values of the EUT would be reported. Otherwise the emissions that did not have 10dB margin would be re-tested one by one using peak, quasi-peak or average method as specified and then reported in a data sheet.

NOTE:

1. The resolution bandwidth and video bandwidth of test receiver/spectrum analyzer is 120kHz for Peak detection (PK) and Quasi-peak detection (QP) at frequency below 1GHz.
2. The resolution bandwidth of test receiver/spectrum analyzer is 1MHz and video bandwidth is 3MHz for Peak detection at frequency above 1GHz.
3. The resolution bandwidth of test receiver/spectrum analyzer is 1MHz and the video bandwidth is 3MHz for RMS Average (Duty cycle < 98%) for Average detection (AV) at frequency above 1GHz, then the measurement results was added to a correction factor (10 log(1/duty cycle)).
4. The resolution bandwidth of test receiver/spectrum analyzer is 1MHz and the video bandwidth is 10Hz (Duty cycle ≥ 98%) for Average detection (AV) at frequency above 1GHz.
5. All modes of operation were investigated and the worst-case emissions are reported.

3.1.5 DEVIATION FROM TEST STANDARD

No deviation.



3.1.6 TEST SETUP

< Frequency Range 30MHz~1GHz >

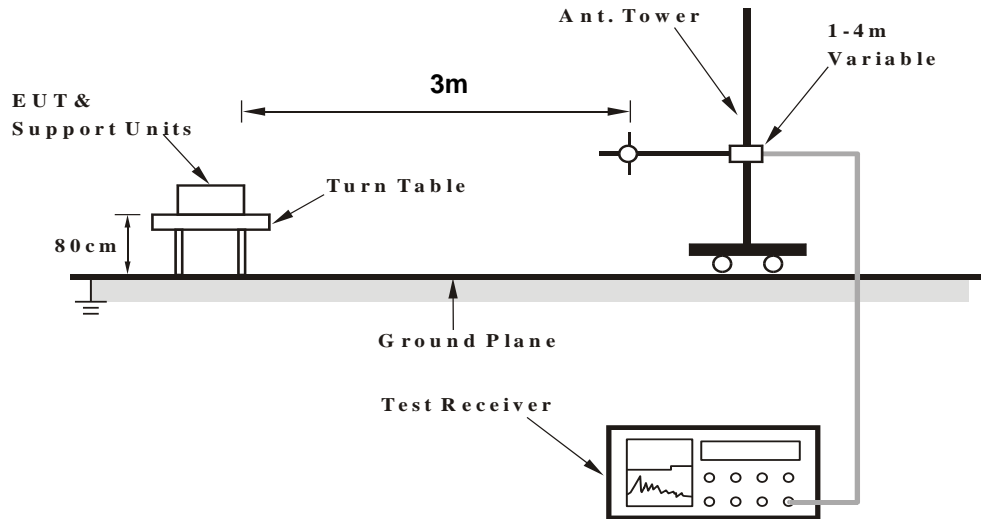

<Frequency Range above 1GHz>

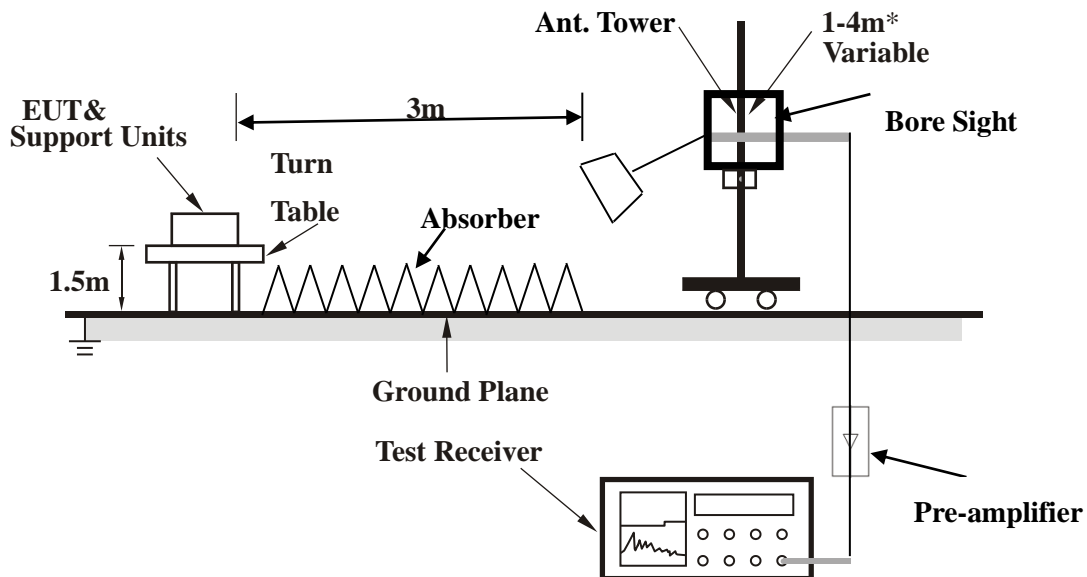

Note: Above 1G is a directional antenna

Depends on the EUT height and the antenna 3dB beamwidth both, refer to section 7.3 of CISPR 16-2-3.

For the actual test configuration, please refer to the attached file (Test Setup Photo).



3.1.7 EUT OPERATING CONDITION

- a. Set the EUT under full load condition and placed them on a testing table.
- b. Set the transmitter part of EUT under transmission condition continuously at specific channel frequency.
- c. The necessary accessories enable the EUT in full functions.



3.1.8 TEST RESULTS

BELOW 1GHz WORST-CASE DATA:

30 MHz – 1GHz data:

802.11n (40MHz)

CHANNEL	TX Channel 38	DETECTOR FUNCTION	Quasi-Peak (QP)
FREQUENCY RANGE	30MHz ~ 1GHz		

ANTENNA POLARITY & TEST DISTANCE: HORIZONTAL AT 3 M										
FREQ. (MHz)	EMISSION LEVEL (dBuV/m)	READ LEVEL (dBuV)	LIMIT (dBuV/m)	MARGIN (dB)	ANTENNA FACTOR (dB /m)	CABLE LOSS (dB)	PREAMP FACTOR (dB)	ANTENNA HEIGHT (cm)	TABLE ANGLE (Degree)	REMARK
89.67	21.86	49.34	43.5	-21.64	8.49	1.28	37.25	100	360	Peak
175.45	25.76	50.38	43.5	-17.74	10.35	1.69	36.66	100	360	Peak
255.46	30.89	52.37	46	-15.11	13.12	2.06	36.66	100	360	Peak
324.65	20.66	40.26	46	-25.34	14.86	2.31	36.77	100	360	Peak
421.35	31.98	48.67	46	-14.02	17.48	2.7	36.87	100	360	Peak
501.32	29.87	45.36	46	-16.13	18.52	2.99	37	100	360	Peak

REMARKS:

1. Emission level (dBuV/m) = Read level (dBuV) + Correction Factor (dB/m).
2. Correction Factor (dB/m) = Antenna Factor (dB/m) + Cable Factor (dB).
3. The other emission levels were very low against the limit.
4. Margin value = Emission level – Limit value.

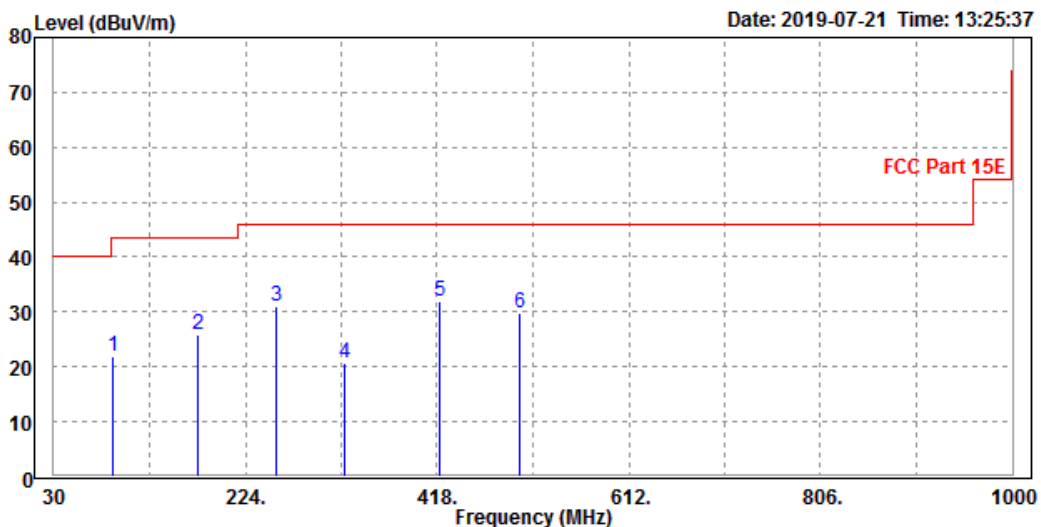



CHANNEL	Channel 38	DETECTOR FUNCTION	Quasi-Peak (QP)
FREQUENCY RANGE	30MHz ~ 1GHz		

ANTENNA POLARITY & TEST DISTANCE: VERTICAL AT 3 M										
FREQ. (MHz)	EMISSION LEVEL (dBuV/m)	READ LEVEL (dBuV)	LIMIT (dBuV/m)	MARGIN (dB)	ANTENNA FACTOR (dB /m)	CABLE LOSS (dB)	PREAMP FACTOR (dB)	ANTENNA HEIGHT (cm)	TABLE ANGLE (Degree)	REMARK
56.32	25.05	54.32	40	-14.95	7.02	1.04	37.33	100	0	Peak
136.67	30.7	57.34	43.5	-12.8	8.77	1.53	36.94	100	0	Peak
211.34	33.4	56.78	43.5	-10.1	11.34	1.85	36.57	100	0	Peak
287.65	28.01	48.62	46	-17.99	13.95	2.17	36.73	100	0	Peak
401.32	36.37	53.26	46	-9.63	17.32	2.62	36.83	100	0	Peak
475.65	29.62	45.32	46	-16.38	18.36	2.9	36.96	100	0	Peak

REMARKS:

1. Emission level (dBuV/m) = Read level (dBuV) + Correction Factor (dB/m).
2. Correction Factor (dB/m) = Antenna Factor (dB/m) + Cable Factor (dB).
3. The other emission levels were very low against the limit.
4. Margin value = Emission level – Limit value.

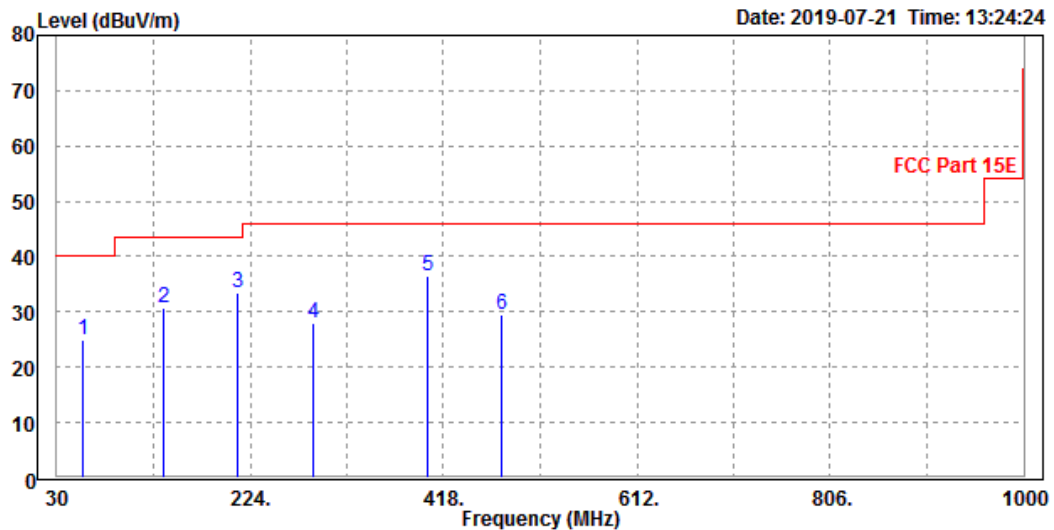



ABOVE 1GHZ WORST-CASE DATA:

Note: For higher frequency, the emission is too low to be detected.

Band 1

802.11a

CHANNEL	TX Channel 36	DETECTOR FUNCTION	Peak (PK)
FREQUENCY RANGE	1GHz ~ 40GHz		Average (AV)

ANTENNA POLARITY & TEST DISTANCE: HORIZONTAL AT 3 M										
FREQ. (MHz)	EMISSION LEVEL (dBuV/m)	READ LEVEL (dBuV)	LIMIT (dBuV/m)	MARGIN (dB)	ANTENNA FACTOR (dB /m)	CABLE LOSS (dB)	PREAMP FACTOR (dB)	ANTENNA HEIGHT (cm)	TABLE ANGLE (Degree)	REMARK
5150	58.34	61.32	74	-15.66	35.95	7.42	46.35	100	165	Peak
5150	46.67	49.65	54	-7.33	35.95	7.42	46.35	100	165	Average
5180	100.71	103.65			35.98	7.43	46.35	100	165	Peak
5180	91.62	94.56			35.98	7.43	46.35	100	165	Average
5350	55.16	57.84	74	-18.84	36.15	7.47	46.3	100	165	Peak
5350	43.63	46.31	54	-10.37	36.15	7.47	46.3	100	165	Average
ANTENNA POLARITY & TEST DISTANCE: VERTICAL AT 3 M										
FREQ. (MHz)	EMISSION LEVEL (dBuV/m)	READ LEVEL (dBuV)	LIMIT (dBuV/m)	MARGIN (dB)	ANTENNA FACTOR (dB /m)	CABLE LOSS (dB)	PREAMP FACTOR (dB)	ANTENNA HEIGHT (cm)	TABLE ANGLE (Degree)	REMARK
5150	60.57	63.21	74	-13.43	36.29	7.42	46.35	100	200	Peak
5150	48.24	50.88	54	-5.76	36.29	7.42	46.35	100	200	Average
5180	104.74	107.35			36.31	7.43	46.35	100	200	Peak
5180	94.74	97.35			36.31	7.43	46.35	100	200	Average
5350	56.95	59.37	74	-17.05	36.41	7.47	46.3	100	200	Peak
5350	44.03	46.45	54	-9.97	36.41	7.47	46.3	100	200	Average

REMARKS:

- Emission Level = Read Level+ Antenna Factor + Cable Loss- Preamp Factor
Margin value = Emission level – Limit value.
- 5180MHz: Fundamental frequency.



CHANNEL	TX Channel 40	DETECTOR FUNCTION	Peak (PK)
FREQUENCY RANGE	1GHz ~ 40GHz		Average (AV)

ANTENNA POLARITY & TEST DISTANCE: HORIZONTAL AT 3 M										
FREQ. (MHz)	EMISSION LEVEL (dBuV/m)	READ LEVEL (dBuV)	LIMIT (dBuV/m)	MARGIN (dB)	ANTENNA FACTOR (dB /m)	CABLE LOSS (dB)	PREAMP FACTOR (dB)	ANTENNA HEIGHT (cm)	TABLE ANGLE (Degree)	REMARK
5150	54.87	57.85	74	-19.13	35.95	7.42	46.35	100	170	Peak
5150	43.37	46.35	54	-10.63	35.95	7.42	46.35	100	170	Average
5200	102.71	105.62			36	7.43	46.34	100	170	Peak
5200	91.67	94.58			36	7.43	46.34	100	170	Average
5350	55.68	58.36	74	-18.32	36.15	7.47	46.3	100	170	Peak
5350	44.44	47.12	54	-9.56	36.15	7.47	46.3	100	170	Average
ANTENNA POLARITY & TEST DISTANCE: VERTICAL AT 3 M										
FREQ. (MHz)	EMISSION LEVEL (dBuV/m)	READ LEVEL (dBuV)	LIMIT (dBuV/m)	MARGIN (dB)	ANTENNA FACTOR (dB /m)	CABLE LOSS (dB)	PREAMP FACTOR (dB)	ANTENNA HEIGHT (cm)	TABLE ANGLE (Degree)	REMARK
5150	55.48	58.12	74	-18.52	36.29	7.42	46.35	150	185	Peak
5150	43.94	46.58	54	-10.06	36.29	7.42	46.35	150	185	Average
5200	104.89	107.48			36.32	7.43	46.34	150	185	Peak
5200	95.86	98.45			36.32	7.43	46.34	150	185	Average
5350	55.82	58.24	74	-18.18	36.41	7.47	46.3	150	185	Peak
5350	44.36	46.78	54	-9.64	36.41	7.47	46.3	150	185	Average

REMARKS:

1. Emission Level = Read Level+ Antenna Factor + Cable Loss- Preamp Factor
Margin value = Emission level – Limit value.
2. 5200MHz: Fundamental frequency.



CHANNEL	TX Channel 48	DETECTOR FUNCTION	Peak (PK)
FREQUENCY RANGE	1GHz ~ 40GHz		Average (AV)

ANTENNA POLARITY & TEST DISTANCE: HORIZONTAL AT 3 M										
FREQ. (MHz)	EMISSION LEVEL (dBuV/m)	READ LEVEL (dBuV)	LIMIT (dBuV/m)	MARGIN (dB)	ANTENNA FACTOR (dB /m)	CABLE LOSS (dB)	PREAMP FACTOR (dB)	ANTENNA HEIGHT (cm)	TABLE ANGLE (Degree)	REMARK
5150	56.19	57.86	74	-17.81	37.26	7.42	46.35	100	166	Peak
5150	44.9	46.57	54	-9.1	37.26	7.42	46.35	100	215	Average
5240	102.56	104.15			37.3	7.44	46.33	100	215	Peak
5240	101.67	103.26			37.3	7.44	46.33	100	215	Average
5350	56.15	57.64	74	-17.85	37.34	7.47	46.3	100	215	Peak
5350	44.72	46.21	54	-9.28	37.34	7.47	46.3	100	215	Average
ANTENNA POLARITY & TEST DISTANCE: VERTICAL AT 3 M										
FREQ. (MHz)	EMISSION LEVEL (dBuV/m)	READ LEVEL (dBuV)	LIMIT (dBuV/m)	MARGIN (dB)	ANTENNA FACTOR (dB /m)	CABLE LOSS (dB)	PREAMP FACTOR (dB)	ANTENNA HEIGHT (cm)	TABLE ANGLE (Degree)	REMARK
5150	55.04	57.68	74	-18.96	36.29	7.42	46.35	100	215	Peak
5150	44.51	47.15	54	-9.49	36.29	7.42	46.35	100	215	Average
5240	103.71	106.26			36.34	7.44	46.33	100	215	Peak
5240	95.3	97.85			36.34	7.44	46.33	100	215	Average
5350	55.22	57.64	74	-18.78	36.41	7.47	46.3	100	215	Peak
5350	44.1	46.52	54	-9.9	36.41	7.47	46.3	100	215	Average

REMARKS:

- Emission Level = Read Level+ Antenna Factor + Cable Loss- Preamp Factor
Margin value = Emission level – Limit value.
- 5240MHz: Fundamental frequency.



802.11n (20MHz)

CHANNEL	TX Channel 36	DETECTOR FUNCTION	Peak (PK)
FREQUENCY RANGE	1GHz ~ 40GHz		Average (AV)

ANTENNA POLARITY & TEST DISTANCE: HORIZONTAL AT 3 M

FREQ. (MHz)	EMISSION LEVEL (dBuV/m)	READ LEVEL (dBuV)	LIMIT (dBuV/m)	MARGIN (dB)	ANTENNA FACTOR (dB /m)	CABLE LOSS (dB)	PREAMP FACTOR (dB)	ANTENNA HEIGHT (cm)	TABLE ANGLE (Degree)	REMARK
5150	57.6	60.58	74	-16.4	35.95	7.42	46.35	100	211	Peak
5150	45.67	48.65	54	-8.33	35.95	7.42	46.35	100	211	Average
5180	99.37	102.31			35.98	7.43	46.35	100	211	Peak
5180	89.3	92.24			35.98	7.43	46.35	100	211	Average
5350	55.96	58.64	74	-18.04	36.15	7.47	46.3	100	211	Peak
5350	43.57	46.25	54	-10.43	36.15	7.47	46.3	100	211	Average

ANTENNA POLARITY & TEST DISTANCE: VERTICAL AT 3 M

FREQ. (MHz)	EMISSION LEVEL (dBuV/m)	READ LEVEL (dBuV)	LIMIT (dBuV/m)	MARGIN (dB)	ANTENNA FACTOR (dB /m)	CABLE LOSS (dB)	PREAMP FACTOR (dB)	ANTENNA HEIGHT (cm)	TABLE ANGLE (Degree)	REMARK
5150	58.48	61.12	74	-15.52	36.29	7.42	46.35	100	205	Peak
5150	45.93	48.57	54	-8.07	36.29	7.42	46.35	100	205	Average
5180	101.73	104.34			36.31	7.43	46.35	100	205	Peak
5180	91.6	94.21			36.31	7.43	46.35	100	205	Average
5350	57.25	59.67	74	-16.75	36.41	7.47	46.3	100	205	Peak
5350	44.09	46.51	54	-9.91	36.41	7.47	46.3	100	205	Average

REMARKS:

- Emission Level = Read Level+ Antenna Factor + Cable Loss- Preamp Factor
Margin value = Emission level – Limit value.
- 5180MHz: Fundamental frequency.



CHANNEL	TX Channel 40	DETECTOR FUNCTION	Peak (PK)
FREQUENCY RANGE	1GHz ~ 40GHz		Average (AV)

ANTENNA POLARITY & TEST DISTANCE: HORIZONTAL AT 3 M										
FREQ. (MHz)	EMISSION LEVEL (dBuV/m)	READ LEVEL (dBuV)	LIMIT (dBuV/m)	MARGIN (dB)	ANTENNA FACTOR (dB /m)	CABLE LOSS (dB)	PREAMP FACTOR (dB)	ANTENNA HEIGHT (cm)	TABLE ANGLE (Degree)	REMARK
5150	55.69	58.67	74	-18.31	35.95	7.42	46.35	100	321	Peak
5150	44.14	47.12	54	-9.86	35.95	7.42	46.35	100	321	Average
5200	99.25	102.16			36	7.43	46.34	100	321	Peak
5200	89.44	92.35			36	7.43	46.34	100	321	Average
5350	55.93	58.61	74	-18.07	36.15	7.47	46.3	100	321	Peak
5350	43.44	46.12	54	-10.56	36.15	7.47	46.3	100	321	Average
ANTENNA POLARITY & TEST DISTANCE: VERTICAL AT 3 M										
FREQ. (MHz)	EMISSION LEVEL (dBuV/m)	READ LEVEL (dBuV)	LIMIT (dBuV/m)	MARGIN (dB)	ANTENNA FACTOR (dB /m)	CABLE LOSS (dB)	PREAMP FACTOR (dB)	ANTENNA HEIGHT (cm)	TABLE ANGLE (Degree)	REMARK
5150	55.25	57.89	74	-18.75	36.29	7.42	46.35	145	345	Peak
5150	43.94	46.58	54	-10.06	36.29	7.42	46.35	145	345	Average
5200	101.94	104.53			36.32	7.43	46.34	145	345	Peak
5200	91.62	94.21			36.32	7.43	46.34	145	345	Average
5350	56.06	58.48	74	-17.94	36.41	7.47	46.3	145	345	Peak
5350	43.86	46.28	54	-10.14	36.41	7.47	46.3	145	345	Average

REMARKS:

- Emission Level = Read Level+ Antenna Factor + Cable Loss- Preamp Factor
Margin value = Emission level – Limit value.
- 5200MHz: Fundamental frequency.



CHANNEL	TX Channel 48	DETECTOR FUNCTION	Peak (PK)
FREQUENCY RANGE	1GHz ~ 40GHz		Average (AV)

ANTENNA POLARITY & TEST DISTANCE: HORIZONTAL AT 3 M

FREQ. (MHz)	EMISSION LEVEL (dBuV/m)	READ LEVEL (dBuV)	LIMIT (dBuV/m)	MARGIN (dB)	ANTENNA FACTOR (dB /m)	CABLE LOSS (dB)	PREAMP FACTOR (dB)	ANTENNA HEIGHT (cm)	TABLE ANGLE (Degree)	REMARK
5150	56.38	59.36	74	-17.62	35.95	7.42	46.35	100	155	Peak
5150	44.14	47.12	54	-9.86	35.95	7.42	46.35	100	155	Average
5240	100.79	103.64			36.04	7.44	46.33	100	155	Peak
5240	90.4	93.25			36.04	7.44	46.33	100	155	Average
5350	55.81	58.49	74	-18.19	36.15	7.47	46.3	100	155	Peak
5350	43.64	46.32	54	-10.36	36.15	7.47	46.3	100	155	Average

ANTENNA POLARITY & TEST DISTANCE: VERTICAL AT 3 M

FREQ. (MHz)	EMISSION LEVEL (dBuV/m)	READ LEVEL (dBuV)	LIMIT (dBuV/m)	MARGIN (dB)	ANTENNA FACTOR (dB /m)	CABLE LOSS (dB)	PREAMP FACTOR (dB)	ANTENNA HEIGHT (cm)	TABLE ANGLE (Degree)	REMARK
5150	56.99	59.63	74	-17.01	36.29	7.42	46.35	100	235	Peak
5150	44.87	47.51	54	-9.13	36.29	7.42	46.35	100	235	Average
5240	102.11	104.66			36.34	7.44	46.33	100	235	Peak
5240	92.03	94.58			36.34	7.44	46.33	100	235	Average
5350	56.21	58.63	74	-17.79	36.41	7.47	46.3	100	235	Peak
5350	43.9	46.32	54	-10.1	36.41	7.47	46.3	100	235	Average

REMARKS:

- Emission Level = Read Level+ Antenna Factor + Cable Loss- Preamp Factor
Margin value = Emission level – Limit value.
- 5240MHz: Fundamental frequency.



802.11n (40MHz)

CHANNEL	TX Channel 38	DETECTOR FUNCTION	Peak (PK)
FREQUENCY RANGE	1GHz ~ 40GHz		Average (AV)

ANTENNA POLARITY & TEST DISTANCE: HORIZONTAL AT 3 M

FREQ. (MHz)	EMISSION LEVEL (dBuV/m)	READ LEVEL (dBuV)	LIMIT (dBuV/m)	MARGIN (dB)	ANTENNA FACTOR (dB /m)	CABLE LOSS (dB)	PREAMP FACTOR (dB)	ANTENNA HEIGHT (cm)	TABLE ANGLE (Degree)	REMARK
5150	58.38	61.36	74	-15.62	35.95	7.42	46.35	100	165	Peak
5150	48.3	51.28	54	-5.7	35.95	7.42	46.35	100	165	Average
5190	95.75	98.67			35.99	7.43	46.34	100	165	Peak
5190	86.53	89.45			35.99	7.43	46.34	100	165	Average
5350	55.21	57.89	74	-18.79	36.15	7.47	46.3	100	165	Peak
5350	44.64	47.32	54	-9.36	36.15	7.47	46.3	100	165	Average

ANTENNA POLARITY & TEST DISTANCE: VERTICAL AT 3 M

FREQ. (MHz)	EMISSION LEVEL (dBuV/m)	READ LEVEL (dBuV)	LIMIT (dBuV/m)	MARGIN (dB)	ANTENNA FACTOR (dB /m)	CABLE LOSS (dB)	PREAMP FACTOR (dB)	ANTENNA HEIGHT (cm)	TABLE ANGLE (Degree)	REMARK
5150	63.91	66.55	74	-10.09	36.29	7.42	46.35	100	210	Peak
5150	49.84	52.48	54	-4.16	36.29	7.42	46.35	100	210	Average
5190	96.65	99.25			36.31	7.43	46.34	100	210	Peak
5190	87.07	89.67			36.31	7.43	46.34	100	210	Average
5350	56.22	58.64	74	-17.78	36.41	7.47	46.3	100	210	Peak
5350	44.79	47.21	54	-9.21	36.41	7.47	46.3	100	210	Average

REMARKS:

- Emission Level = Read Level+ Antenna Factor + Cable Loss- Preamp Factor
Margin value = Emission level – Limit value.
- 5190MHz: Fundamental frequency.



CHANNEL	TX Channel 46	DETECTOR FUNCTION	Peak (PK)
FREQUENCY RANGE	1GHz ~ 40GHz		Average (AV)

ANTENNA POLARITY & TEST DISTANCE: HORIZONTAL AT 3 M

FREQ. (MHz)	EMISSION LEVEL (dBuV/m)	READ LEVEL (dBuV)	LIMIT (dBuV/m)	MARGIN (dB)	ANTENNA FACTOR (dB /m)	CABLE LOSS (dB)	PREAMP FACTOR (dB)	ANTENNA HEIGHT (cm)	TABLE ANGLE (Degree)	REMARK
5150	57.77	60.75	74	-16.23	35.95	7.42	46.35	105	320	Peak
5150	43.88	46.86	54	-10.12	35.95	7.42	46.35	105	320	Average
5230	96.79	99.65			36.03	7.44	46.33	105	320	Peak
5230	86.62	89.48			36.03	7.44	46.33	105	320	Average
5350	56.64	59.32	74	-17.36	36.15	7.47	46.3	105	320	Peak
5350	44.57	47.25	54	-9.43	36.15	7.47	46.3	105	320	Average

ANTENNA POLARITY & TEST DISTANCE: VERTICAL AT 3 M

FREQ. (MHz)	EMISSION LEVEL (dBuV/m)	READ LEVEL (dBuV)	LIMIT (dBuV/m)	MARGIN (dB)	ANTENNA FACTOR (dB /m)	CABLE LOSS (dB)	PREAMP FACTOR (dB)	ANTENNA HEIGHT (cm)	TABLE ANGLE (Degree)	REMARK
5150	57.04	59.68	74	-16.96	36.29	7.42	46.35	100	127	Peak
5150	44.72	47.36	54	-9.28	36.29	7.42	46.35	100	127	Average
5230	99.8	102.35			36.34	7.44	46.33	100	127	Peak
5230	91.1	93.65			36.34	7.44	46.33	100	127	Average
5350	57.22	59.64	74	-16.78	36.41	7.47	46.3	100	127	Peak
5350	45.09	47.51	54	-8.91	36.41	7.47	46.3	100	127	Average

REMARKS:

- Emission Level = Read Level+ Antenna Factor + Cable Loss- Preamp Factor
Margin value = Emission level – Limit value.
- 5230MHz: Fundamental frequency.



802.11ac (80MHz)

CHANNEL	TX Channel 42	DETECTOR FUNCTION	Peak (PK)
FREQUENCY RANGE	1GHz ~ 40GHz		Average (AV)

ANTENNA POLARITY & TEST DISTANCE: HORIZONTAL AT 3 M

FREQ. (MHz)	EMISSION LEVEL (dBuV/m)	READ LEVEL (dBuV)	LIMIT (dBuV/m)	MARGIN (dB)	ANTENNA FACTOR (dB /m)	CABLE LOSS (dB)	PREAMP FACTOR (dB)	ANTENNA HEIGHT (cm)	TABLE ANGLE (Degree)	REMARK
5150	58.25	61.23	74	-15.75	35.95	7.42	46.35	155	312	Peak
5150	45.23	48.21	54	-8.77	35.95	7.42	46.35	155	312	Average
5210	92.35	95.24			36.01	7.44	46.34	155	312	Peak
5210	83.86	86.75			36.01	7.44	46.34	155	312	Average
5350	57	59.68	74	-17	36.15	7.47	46.3	155	312	Peak
5350	44.95	47.63	54	-9.05	36.15	7.47	46.3	155	312	Average

ANTENNA POLARITY & TEST DISTANCE: VERTICAL AT 3 M

FREQ. (MHz)	EMISSION LEVEL (dBuV/m)	READ LEVEL (dBuV)	LIMIT (dBuV/m)	MARGIN (dB)	ANTENNA FACTOR (dB /m)	CABLE LOSS (dB)	PREAMP FACTOR (dB)	ANTENNA HEIGHT (cm)	TABLE ANGLE (Degree)	REMARK
5150	59.95	62.59	74	-14.05	36.29	7.42	46.35	100	135	Peak
5150	46.77	49.41	54	-7.23	36.29	7.42	46.35	100	135	Average
5210	93.77	96.34			36.33	7.44	46.34	100	135	Peak
5210	84.97	87.54			36.33	7.44	46.34	100	135	Average
5350	57.89	60.31	74	-16.11	36.41	7.47	46.3	100	135	Peak
5350	45.14	47.56	54	-8.86	36.41	7.47	46.3	100	135	Average

REMARKS:

- Emission Level = Read Level+ Antenna Factor + Cable Loss- Preamp Factor
Margin value = Emission level – Limit value.
- 5210MHz: Fundamental frequency.



**Band 2
802.11a**

CHANNEL	TX Channel 52	DETECTOR FUNCTION	Peak (PK)
FREQUENCY RANGE	1GHz ~ 40GHz		Average (AV)

ANTENNA POLARITY & TEST DISTANCE: HORIZONTAL AT 3 M

FREQ. (MHz)	EMISSION LEVEL (dBuV/m)	READ LEVEL (dBuV)	LIMIT (dBuV/m)	MARGIN (dB)	ANTENNA FACTOR (dB /m)	CABLE LOSS (dB)	PREAMP FACTOR (dB)	ANTENNA HEIGHT (cm)	TABLE ANGLE (Degree)	REMARK
5150	56.65	59.63	74	-17.35	35.95	7.42	46.35	100	130	Peak
5150	43.38	46.36	54	-10.62	35.95	7.42	46.35	100	130	Average
5260	99.54	102.35			36.06	7.45	46.32	100	130	Peak
5260	90.4	93.21			36.06	7.45	46.32	100	130	Average
5350	55.99	58.67	74	-18.01	36.15	7.47	46.3	100	130	Peak
5350	43.68	46.36	54	-10.32	36.15	7.47	46.3	100	130	Average

ANTENNA POLARITY & TEST DISTANCE: VERTICAL AT 3 M

FREQ. (MHz)	EMISSION LEVEL (dBuV/m)	READ LEVEL (dBuV)	LIMIT (dBuV/m)	MARGIN (dB)	ANTENNA FACTOR (dB /m)	CABLE LOSS (dB)	PREAMP FACTOR (dB)	ANTENNA HEIGHT (cm)	TABLE ANGLE (Degree)	REMARK
5150	58.31	60.95	74	-15.69	36.29	7.42	46.35	100	231	Peak
5150	45	47.64	54	-9	36.29	7.42	46.35	100	231	Average
5260	101.89	104.4			36.36	7.45	46.32	100	231	Peak
5260	92.73	95.24			36.36	7.45	46.32	100	231	Average
5350	57.45	59.87	74	-16.55	36.41	7.47	46.3	100	231	Peak
5350	44.15	46.57	54	-9.85	36.41	7.47	46.3	100	231	Average

REMARKS:

- Emission Level = Read Level+ Antenna Factor + Cable Loss- Preamp Factor
Margin value = Emission level – Limit value.
- 5260MHz: Fundamental frequency.



CHANNEL	TX Channel 60	DETECTOR FUNCTION	Peak (PK)
FREQUENCY RANGE	1GHz ~ 40GHz		Average (AV)

ANTENNA POLARITY & TEST DISTANCE: HORIZONTAL AT 3 M

FREQ. (MHz)	EMISSION LEVEL (dBuV/m)	READ LEVEL (dBuV)	LIMIT (dBuV/m)	MARGIN (dB)	ANTENNA FACTOR (dB /m)	CABLE LOSS (dB)	PREAMP FACTOR (dB)	ANTENNA HEIGHT (cm)	TABLE ANGLE (Degree)	REMARK
5150	57.7	60.68	74	-16.3	35.95	7.42	46.35	100	125	Peak
5150	44.17	47.15	54	-9.83	35.95	7.42	46.35	100	125	Average
5300	99.56	102.31			36.1	7.46	46.31	100	125	Peak
5300	90.5	93.25			36.1	7.46	46.31	100	125	Average
5350	55.94	58.62	74	-18.06	36.15	7.47	46.3	100	125	Peak
5350	43.7	46.38	54	-10.3	36.15	7.47	46.3	100	125	Average

ANTENNA POLARITY & TEST DISTANCE: VERTICAL AT 3 M

FREQ. (MHz)	EMISSION LEVEL (dBuV/m)	READ LEVEL (dBuV)	LIMIT (dBuV/m)	MARGIN (dB)	ANTENNA FACTOR (dB /m)	CABLE LOSS (dB)	PREAMP FACTOR (dB)	ANTENNA HEIGHT (cm)	TABLE ANGLE (Degree)	REMARK
5150	57.68	60.32	74	-16.32	36.29	7.42	46.35	100	26	Peak
5150	44.01	46.65	54	-9.99	36.29	7.42	46.35	100	26	Average
5300	102.87	105.34			36.38	7.46	46.31	100	26	Peak
5300	93.22	95.69			36.38	7.46	46.31	100	26	Average
5350	57.84	60.26	74	-16.16	36.41	7.47	46.3	100	26	Peak
5350	45.16	47.58	54	-8.84	36.41	7.47	46.3	100	26	Average

REMARKS:

- Emission Level = Read Level+ Antenna Factor + Cable Loss- Preamp Factor
Margin value = Emission level – Limit value.
- 5300MHz: Fundamental frequency.



CHANNEL	TX Channel 64	DETECTOR FUNCTION	Peak (PK)
FREQUENCY RANGE	1GHz ~ 40GHz		Average (AV)

ANTENNA POLARITY & TEST DISTANCE: HORIZONTAL AT 3 M

FREQ. (MHz)	EMISSION LEVEL (dBuV/m)	READ LEVEL (dBuV)	LIMIT (dBuV/m)	MARGIN (dB)	ANTENNA FACTOR (dB /m)	CABLE LOSS (dB)	PREAMP FACTOR (dB)	ANTENNA HEIGHT (cm)	TABLE ANGLE (Degree)	REMARK
5150	55.98	58.96	74	-18.02	35.95	7.42	46.35	100	135	Peak
5150	43.8	46.78	54	-10.2	35.95	7.42	46.35	100	135	Average
5320	97.49	100.21			36.12	7.46	46.3	100	135	Peak
5320	87.63	90.35			36.12	7.46	46.3	100	135	Average
5350	57.9	60.58	74	-16.1	36.15	7.47	46.3	100	135	Peak
5350	45.11	47.79	54	-8.89	36.15	7.47	46.3	100	135	Average

ANTENNA POLARITY & TEST DISTANCE: VERTICAL AT 3 M

FREQ. (MHz)	EMISSION LEVEL (dBuV/m)	READ LEVEL (dBuV)	LIMIT (dBuV/m)	MARGIN (dB)	ANTENNA FACTOR (dB /m)	CABLE LOSS (dB)	PREAMP FACTOR (dB)	ANTENNA HEIGHT (cm)	TABLE ANGLE (Degree)	REMARK
5150	57	59.64	74	-17	36.29	7.42	46.35	100	232	Peak
5150	44.31	46.95	54	-9.69	36.29	7.42	46.35	100	232	Average
5320	99.1	101.55			36.39	7.46	46.3	100	232	Peak
5320	88.91	91.36			36.39	7.46	46.3	100	232	Average
5350	58.93	61.35	74	-15.07	36.41	7.47	46.3	100	232	Peak
5350	46.27	48.69	54	-7.73	36.41	7.47	46.3	100	232	Average

REMARKS:

- Emission Level = Read Level+ Antenna Factor + Cable Loss- Preamp Factor
Margin value = Emission level – Limit value.
- 5320MHz: Fundamental frequency.



802.11n (20MHz)

CHANNEL	TX Channel 52	DETECTOR FUNCTION	Peak (PK)
FREQUENCY RANGE	1GHz ~ 40GHz		Average (AV)

ANTENNA POLARITY & TEST DISTANCE: HORIZONTAL AT 3 M

FREQ. (MHz)	EMISSION LEVEL (dBuV/m)	READ LEVEL (dBuV)	LIMIT (dBuV/m)	MARGIN (dB)	ANTENNA FACTOR (dB /m)	CABLE LOSS (dB)	PREAMP FACTOR (dB)	ANTENNA HEIGHT (cm)	TABLE ANGLE (Degree)	REMARK
5150	56.65	59.63	74	-17.35	35.95	7.42	46.35	100	135	Peak
5150	44.64	47.62	54	-9.36	35.95	7.42	46.35	100	135	Average
5260	97.51	100.32			36.06	7.45	46.32	100	135	Peak
5260	87.44	90.25			36.06	7.45	46.32	100	135	Average
5350	57	59.68	74	-17	36.15	7.47	46.3	100	135	Peak
5350	44.9	47.58	54	-9.1	36.15	7.47	46.3	100	135	Average

ANTENNA POLARITY & TEST DISTANCE: VERTICAL AT 3 M

FREQ. (MHz)	EMISSION LEVEL (dBuV/m)	READ LEVEL (dBuV)	LIMIT (dBuV/m)	MARGIN (dB)	ANTENNA FACTOR (dB /m)	CABLE LOSS (dB)	PREAMP FACTOR (dB)	ANTENNA HEIGHT (cm)	TABLE ANGLE (Degree)	REMARK
5150	56.05	58.69	74	-17.95	36.29	7.42	46.35	100	23	Peak
5150	44.87	47.51	54	-9.13	36.29	7.42	46.35	100	23	Average
5260	99.83	102.34			36.36	7.45	46.32	100	23	Peak
5260	90.06	92.57			36.36	7.45	46.32	100	23	Average
5350	55.44	57.86	74	-18.56	36.41	7.47	46.3	100	23	Peak
5350	44.94	47.36	54	-9.06	36.41	7.47	46.3	100	23	Average

REMARKS:

- Emission Level = Read Level+ Antenna Factor + Cable Loss- Preamp Factor
Margin value = Emission level – Limit value.
- 5260MHz: Fundamental frequency.



CHANNEL	TX Channel 60	DETECTOR FUNCTION	Peak (PK)
FREQUENCY RANGE	1GHz ~ 40GHz		Average (AV)

ANTENNA POLARITY & TEST DISTANCE: HORIZONTAL AT 3 M

FREQ. (MHz)	EMISSION LEVEL (dBuV/m)	READ LEVEL (dBuV)	LIMIT (dBuV/m)	MARGIN (dB)	ANTENNA FACTOR (dB /m)	CABLE LOSS (dB)	PREAMP FACTOR (dB)	ANTENNA HEIGHT (cm)	TABLE ANGLE (Degree)	REMARK
5150	55.66	58.64	74	-18.34	35.95	7.42	46.35	100	132	Peak
5150	44.04	47.02	54	-9.96	35.95	7.42	46.35	100	132	Average
5300	97.49	100.24			36.1	7.46	46.31	100	132	Peak
5300	87.6	90.35			36.1	7.46	46.31	100	132	Average
5350	56.57	59.25	74	-17.43	36.15	7.47	46.3	100	132	Peak
5350	44.93	47.61	54	-9.07	36.15	7.47	46.3	100	132	Average

ANTENNA POLARITY & TEST DISTANCE: VERTICAL AT 3 M

FREQ. (MHz)	EMISSION LEVEL (dBuV/m)	READ LEVEL (dBuV)	LIMIT (dBuV/m)	MARGIN (dB)	ANTENNA FACTOR (dB /m)	CABLE LOSS (dB)	PREAMP FACTOR (dB)	ANTENNA HEIGHT (cm)	TABLE ANGLE (Degree)	REMARK
5150	57.67	60.31	74	-16.33	36.29	7.42	46.35	100	36	Peak
5150	45.05	47.69	54	-8.95	36.29	7.42	46.35	100	36	Average
5300	99.88	102.35			36.38	7.46	46.31	100	36	Peak
5300	90.04	92.51			36.38	7.46	46.31	100	36	Average
5350	56.54	58.96	74	-17.46	36.41	7.47	46.3	100	36	Peak
5350	44.89	47.31	54	-9.11	36.41	7.47	46.3	100	36	Average

REMARKS:

- Emission Level = Read Level+ Antenna Factor + Cable Loss- Preamp Factor
Margin value = Emission level – Limit value.
- 5300MHz: Fundamental frequency.



CHANNEL	TX Channel 64	DETECTOR FUNCTION	Peak (PK)
FREQUENCY RANGE	1GHz ~ 40GHz		Average (AV)

ANTENNA POLARITY & TEST DISTANCE: HORIZONTAL AT 3 M

FREQ. (MHz)	EMISSION LEVEL (dBuV/m)	READ LEVEL (dBuV)	LIMIT (dBuV/m)	MARGIN (dB)	ANTENNA FACTOR (dB /m)	CABLE LOSS (dB)	PREAMP FACTOR (dB)	ANTENNA HEIGHT (cm)	TABLE ANGLE (Degree)	REMARK
5150	56.7	59.68	74	-17.3	35.95	7.42	46.35	100	145	Peak
5150	44.27	47.25	54	-9.73	35.95	7.42	46.35	100	145	Average
5320	98.84	101.56			36.12	7.46	46.3	100	145	Peak
5320	88.7	91.42			36.12	7.46	46.3	100	145	Average
5350	58.55	61.23	74	-15.45	36.15	7.47	46.3	100	145	Peak
5350	46.53	49.21	54	-7.47	36.15	7.47	46.3	100	145	Average

ANTENNA POLARITY & TEST DISTANCE: VERTICAL AT 3 M

FREQ. (MHz)	EMISSION LEVEL (dBuV/m)	READ LEVEL (dBuV)	LIMIT (dBuV/m)	MARGIN (dB)	ANTENNA FACTOR (dB /m)	CABLE LOSS (dB)	PREAMP FACTOR (dB)	ANTENNA HEIGHT (cm)	TABLE ANGLE (Degree)	REMARK
5150	57.14	59.78	74	-16.86	36.29	7.42	46.35	100	35	Peak
5150	44.64	47.28	54	-9.36	36.29	7.42	46.35	100	35	Average
5320	100.76	103.21			36.39	7.46	46.3	100	35	Peak
5320	90.1	92.55			36.39	7.46	46.3	100	35	Average
5350	59.94	62.36	74	-14.06	36.41	7.47	46.3	100	35	Peak
5350	47.82	50.24	54	-6.18	36.41	7.47	46.3	100	35	Average

REMARKS:

- Emission Level = Read Level+ Antenna Factor + Cable Loss- Preamp Factor
Margin value = Emission level – Limit value.
- 5320MHz: Fundamental frequency.



802.11n (40MHz)

CHANNEL	TX Channel 54	DETECTOR FUNCTION	Peak (PK)
FREQUENCY RANGE	1GHz ~ 40GHz		Average (AV)

ANTENNA POLARITY & TEST DISTANCE: HORIZONTAL AT 3 M

FREQ. (MHz)	EMISSION LEVEL (dBuV/m)	READ LEVEL (dBuV)	LIMIT (dBuV/m)	MARGIN (dB)	ANTENNA FACTOR (dB /m)	CABLE LOSS (dB)	PREAMP FACTOR (dB)	ANTENNA HEIGHT (cm)	TABLE ANGLE (Degree)	REMARK
5150	56.69	59.67	74	-17.31	35.95	7.42	46.35	100	138	Peak
5150	44.34	47.32	54	-9.66	35.95	7.42	46.35	100	138	Average
5270	97.77	100.57			36.07	7.45	46.32	100	138	Peak
5270	87.85	90.65			36.07	7.45	46.32	100	138	Average
5350	57.01	59.69	74	-16.99	36.15	7.47	46.3	100	138	Peak
5350	44.9	47.58	54	-9.1	36.15	7.47	46.3	100	138	Average

ANTENNA POLARITY & TEST DISTANCE: VERTICAL AT 3 M

FREQ. (MHz)	EMISSION LEVEL (dBuV/m)	READ LEVEL (dBuV)	LIMIT (dBuV/m)	MARGIN (dB)	ANTENNA FACTOR (dB /m)	CABLE LOSS (dB)	PREAMP FACTOR (dB)	ANTENNA HEIGHT (cm)	TABLE ANGLE (Degree)	REMARK
5150	57.57	60.21	74	-16.43	36.29	7.42	46.35	100	38	Peak
5150	45.68	48.32	54	-8.32	36.29	7.42	46.35	100	38	Average
5270	100.77	103.28			36.36	7.45	46.32	100	38	Peak
5270	89.94	92.45			36.36	7.45	46.32	100	38	Average
5350	58.73	61.15	74	-15.27	36.41	7.47	46.3	100	38	Peak
5350	45.21	47.63	54	-8.79	36.41	7.47	46.3	100	38	Average

REMARKS:

- Emission Level = Read Level+ Antenna Factor + Cable Loss- Preamp Factor
Margin value = Emission level – Limit value.
- 5270MHz: Fundamental frequency.



CHANNEL	TX Channel 62	DETECTOR FUNCTION	Peak (PK)
FREQUENCY RANGE	1GHz ~ 40GHz		Average (AV)

ANTENNA POLARITY & TEST DISTANCE: HORIZONTAL AT 3 M

FREQ. (MHz)	EMISSION LEVEL (dBuV/m)	READ LEVEL (dBuV)	LIMIT (dBuV/m)	MARGIN (dB)	ANTENNA FACTOR (dB /m)	CABLE LOSS (dB)	PREAMP FACTOR (dB)	ANTENNA HEIGHT (cm)	TABLE ANGLE (Degree)	REMARK
5150	57.37	60.35	74	-16.63	35.95	7.42	46.35	100	132	Peak
5150	44.91	47.89	54	-9.09	35.95	7.42	46.35	100	132	Average
5310	98.51	101.25			36.11	7.46	46.31	100	132	Peak
5310	88.1	90.84			36.11	7.46	46.31	100	132	Average
5350	60	62.68	74	-14	36.15	7.47	46.3	100	132	Peak
5350	48.67	51.35	54	-5.33	36.15	7.47	46.3	100	132	Average

ANTENNA POLARITY & TEST DISTANCE: VERTICAL AT 3 M

FREQ. (MHz)	EMISSION LEVEL (dBuV/m)	READ LEVEL (dBuV)	LIMIT (dBuV/m)	MARGIN (dB)	ANTENNA FACTOR (dB /m)	CABLE LOSS (dB)	PREAMP FACTOR (dB)	ANTENNA HEIGHT (cm)	TABLE ANGLE (Degree)	REMARK
5150	57.72	60.36	74	-16.28	36.29	7.42	46.35	100	35	Peak
5150	45	47.64	54	-9	36.29	7.42	46.35	100	35	Average
5310	100.75	103.21			36.39	7.46	46.31	100	35	Peak
5310	90.78	93.24			36.39	7.46	46.31	100	35	Average
5350	61.14	63.56	74	-12.86	36.41	7.47	46.3	100	35	Peak
5350	49.7	52.12	54	-4.3	36.41	7.47	46.3	100	35	Average

REMARKS:

- Emission Level = Read Level+ Antenna Factor + Cable Loss- Preamp Factor
Margin value = Emission level – Limit value.
- 5310MHz: Fundamental frequency.



802.11ac (80MHz)

CHANNEL	TX Channel 58	DETECTOR FUNCTION	Peak (PK)
FREQUENCY RANGE	1GHz ~ 40GHz		Average (AV)

ANTENNA POLARITY & TEST DISTANCE: HORIZONTAL AT 3 M

FREQ. (MHz)	EMISSION LEVEL (dBuV/m)	READ LEVEL (dBuV)	LIMIT (dBuV/m)	MARGIN (dB)	ANTENNA FACTOR (dB /m)	CABLE LOSS (dB)	PREAMP FACTOR (dB)	ANTENNA HEIGHT (cm)	TABLE ANGLE (Degree)	REMARK
5150	57.33	60.31	74	-16.67	35.95	7.42	46.35	100	132	Peak
5150	44.27	47.25	54	-9.73	35.95	7.42	46.35	100	132	Average
5290	97.9	100.67			36.09	7.45	46.31	100	132	Peak
5290	87.38	90.15			36.09	7.45	46.31	100	132	Average
5350	59.9	62.58	74	-14.1	36.15	7.47	46.3	100	132	Peak
5350	48.56	51.24	54	-5.44	36.15	7.47	46.3	100	132	Average

ANTENNA POLARITY & TEST DISTANCE: VERTICAL AT 3 M

FREQ. (MHz)	EMISSION LEVEL (dBuV/m)	READ LEVEL (dBuV)	LIMIT (dBuV/m)	MARGIN (dB)	ANTENNA FACTOR (dB /m)	CABLE LOSS (dB)	PREAMP FACTOR (dB)	ANTENNA HEIGHT (cm)	TABLE ANGLE (Degree)	REMARK
5150	57.12	59.76	74	-16.88	36.29	7.42	46.35	100	132	Peak
5150	45.05	47.69	54	-8.95	36.29	7.42	46.35	100	132	Average
5290	99.96	102.45			36.37	7.45	46.31	100	132	Peak
5290	90.19	92.68			36.37	7.45	46.31	100	132	Average
5350	61.12	63.54	74	-12.88	36.41	7.47	46.3	100	132	Peak
5350	48.74	51.16	54	-5.26	36.41	7.47	46.3	100	132	Average

REMARKS:

- Emission Level = Read Level+ Antenna Factor + Cable Loss- Preamp Factor
Margin value = Emission level – Limit value.
- 5290MHz: Fundamental frequency.



Band 3

802.11a

CHANNEL	TX Channel 100	DETECTOR FUNCTION	Peak (PK)
FREQUENCY RANGE	1GHz ~ 40GHz		Average (AV)

ANTENNA POLARITY & TEST DISTANCE: HORIZONTAL AT 3 M

FREQ. (MHz)	EMISSION LEVEL (dBuV/m)	READ LEVEL (dBuV)	LIMIT (dBuV/m)	MARGIN (dB)	ANTENNA FACTOR (dB /m)	CABLE LOSS (dB)	PREAMP FACTOR (dB)	ANTENNA HEIGHT (cm)	TABLE ANGLE (Degree)	REMARK
5460	58.84	61.35	74	-15.16	36.26	7.49	46.26	100	135	Peak
5460	45.4	47.91	54	-8.6	36.26	7.49	46.26	100	135	Average
#5470	59.62	62.12	68.3	-8.68	36.27	7.49	46.26	100	135	Peak
5500	100.91	103.36			36.3	7.5	46.25	100	135	Peak
5500	91.8	94.25			36.3	7.5	46.25	100	135	Average

ANTENNA POLARITY & TEST DISTANCE: VERTICAL AT 3 M

FREQ. (MHz)	EMISSION LEVEL (dBuV/m)	READ LEVEL (dBuV)	LIMIT (dBuV/m)	MARGIN (dB)	ANTENNA FACTOR (dB /m)	CABLE LOSS (dB)	PREAMP FACTOR (dB)	ANTENNA HEIGHT (cm)	TABLE ANGLE (Degree)	REMARK
5460	59.35	61.64	74	-14.65	36.48	7.49	46.26	100	66	Peak
5460	45.83	48.12	54	-8.17	36.48	7.49	46.26	100	66	Average
#5470	60.48	62.77	68.3	-7.82	36.48	7.49	46.26	100	66	Peak
5500	103.85	106.1			36.5	7.5	46.25	100	66	Peak
5500	96.5	98.75			36.5	7.5	46.25	100	66	Average

REMARKS:

1. Emission Level = Read Level+ Antenna Factor + Cable Loss- Preamp Factor
Margin value = Emission level – Limit value.
2. 5500MHz: Fundamental frequency.
3. #: Out of restricted band.



CHANNEL	TX Channel 116	DETECTOR FUNCTION	Peak (PK)
FREQUENCY RANGE	1GHz ~ 40GHz		Average (AV)

ANTENNA POLARITY & TEST DISTANCE: HORIZONTAL AT 3 M

FREQ. (MHz)	EMISSION LEVEL (dBuV/m)	READ LEVEL (dBuV)	LIMIT (dBuV/m)	MARGIN (dB)	ANTENNA FACTOR (dB /m)	CABLE LOSS (dB)	PREAMP FACTOR (dB)	ANTENNA HEIGHT (cm)	TABLE ANGLE (Degree)	REMARK
5460	58.13	60.64	74	-15.87	36.26	7.49	46.26	100	136	Peak
5460	44.74	47.25	54	-9.26	36.26	7.49	46.26	100	136	Average
#5470	58.48	60.98	68.3	-9.82	36.27	7.49	46.26	100	136	Peak
5580	101.9	104.22			36.33	7.58	46.23	100	136	Peak
5580	91.37	93.69			36.33	7.58	46.23	100	136	Average

ANTENNA POLARITY & TEST DISTANCE: VERTICAL AT 3 M

FREQ. (MHz)	EMISSION LEVEL (dBuV/m)	READ LEVEL (dBuV)	LIMIT (dBuV/m)	MARGIN (dB)	ANTENNA FACTOR (dB /m)	CABLE LOSS (dB)	PREAMP FACTOR (dB)	ANTENNA HEIGHT (cm)	TABLE ANGLE (Degree)	REMARK
5460	58.4	60.69	74	-15.6	36.48	7.49	46.26	100	25	Peak
5460	44.56	46.85	54	-9.44	36.48	7.49	46.26	100	25	Average
#5470	58.96	61.25	68.3	-9.34	36.48	7.49	46.26	100	25	Peak
5580	103.52	105.62			36.55	7.58	46.23	100	25	Peak
5580	95.35	97.45			36.55	7.58	46.23	100	25	Average

REMARKS:

- Emission Level = Read Level+ Antenna Factor + Cable Loss- Preamp Factor
Margin value = Emission level – Limit value.
- 5580MHz: Fundamental frequency.
- #: Out of restricted band.



CHANNEL	TX Channel 140	DETECTOR FUNCTION	Peak (PK)
FREQUENCY RANGE	1GHz ~ 40GHz		Average (AV)

ANTENNA POLARITY & TEST DISTANCE: HORIZONTAL AT 3 M										
FREQ. (MHz)	EMISSION LEVEL (dBuV/m)	READ LEVEL (dBuV)	LIMIT (dBuV/m)	MARGIN (dB)	ANTENNA FACTOR (dB /m)	CABLE LOSS (dB)	PREAMP FACTOR (dB)	ANTENNA HEIGHT (cm)	TABLE ANGLE (Degree)	REMARK
5700	100.35	102.46			36.38	7.7	46.19	100	148	Peak
5700	92.47	94.58			36.38	7.7	46.19	100	148	Average
#5725	59.19	61.26	68.3	-9.11	36.39	7.73	46.19	100	148	Peak
ANTENNA POLARITY & TEST DISTANCE: VERTICAL AT 3 M										
FREQ. (MHz)	EMISSION LEVEL (dBuV/m)	READ LEVEL (dBuV)	LIMIT (dBuV/m)	MARGIN (dB)	ANTENNA FACTOR (dB /m)	CABLE LOSS (dB)	PREAMP FACTOR (dB)	ANTENNA HEIGHT (cm)	TABLE ANGLE (Degree)	REMARK
5700	103.43	105.3			36.62	7.7	46.19	100	45	Peak
5700	94.97	96.84			36.62	7.7	46.19	100	45	Average
#5725	60.53	62.36	68.3	-7.77	36.63	7.73	46.19	100	45	Peak

REMARKS:

- Emission Level = Read Level+ Antenna Factor + Cable Loss- Preamp Factor
Margin value = Emission level – Limit value.
- 5700MHz: Fundamental frequency.
- #: Out of restricted band.



802.11n (20MHz)

CHANNEL	TX Channel 100	DETECTOR FUNCTION	Peak (PK)
FREQUENCY RANGE	1GHz ~ 40GHz		Average (AV)

ANTENNA POLARITY & TEST DISTANCE: HORIZONTAL AT 3 M										
FREQ. (MHz)	EMISSION LEVEL (dBuV/m)	READ LEVEL (dBuV)	LIMIT (dBuV/m)	MARGIN (dB)	ANTENNA FACTOR (dB /m)	CABLE LOSS (dB)	PREAMP FACTOR (dB)	ANTENNA HEIGHT (cm)	TABLE ANGLE (Degree)	REMARK
5460	59.3	61.59	74	-14.7	36.48	7.49	46.26	100	124	Peak
5460	45.86	48.15	54	-8.14	36.48	7.49	46.26	100	124	Average
#5470	60.34	62.63	68.3	-7.96	36.48	7.49	46.26	100	124	Peak
5500	101.98	104.23			36.5	7.5	46.25	100	124	Peak
5500	92.32	94.57			36.5	7.5	46.25	100	124	Average
ANTENNA POLARITY & TEST DISTANCE: VERTICAL AT 3 M										
FREQ. (MHz)	EMISSION LEVEL (dBuV/m)	READ LEVEL (dBuV)	LIMIT (dBuV/m)	MARGIN (dB)	ANTENNA FACTOR (dB /m)	CABLE LOSS (dB)	PREAMP FACTOR (dB)	ANTENNA HEIGHT (cm)	TABLE ANGLE (Degree)	REMARK
5460	58.96	61.25	74	-15.04	36.48	7.49	46.26	100	36	Peak
5460	45.57	47.86	54	-8.43	36.48	7.49	46.26	100	36	Average
#5470	59.84	62.13	68.3	-8.46	36.48	7.49	46.26	100	36	Peak
5500	99.07	101.32			36.5	7.5	46.25	100	36	Peak
5500	89.9	92.15			36.5	7.5	46.25	100	36	Average

REMARKS:

- Emission Level = Read Level+ Antenna Factor + Cable Loss- Preamp Factor
Margin value = Emission level – Limit value.
- 5500MHz: Fundamental frequency.
- #: Out of restricted band.



CHANNEL	TX Channel 116	DETECTOR FUNCTION	Peak (PK)
FREQUENCY RANGE	1GHz ~ 40GHz		Average (AV)

ANTENNA POLARITY & TEST DISTANCE: HORIZONTAL AT 3 M

FREQ. (MHz)	EMISSION LEVEL (dBuV/m)	READ LEVEL (dBuV)	LIMIT (dBuV/m)	MARGIN (dB)	ANTENNA FACTOR (dB /m)	CABLE LOSS (dB)	PREAMP FACTOR (dB)	ANTENNA HEIGHT (cm)	TABLE ANGLE (Degree)	REMARK
5460	58.38	60.89	74	-15.62	36.26	7.49	46.26	100	126	Peak
5460	44.61	47.12	54	-9.39	36.26	7.49	46.26	100	126	Average
#5470	58.75	61.25	68.3	-9.55	36.27	7.49	46.26	100	126	Peak
5580	98.34	100.66			36.33	7.58	46.23	100	126	Peak
5580	90	92.32			36.33	7.58	46.23	100	126	Average

ANTENNA POLARITY & TEST DISTANCE: VERTICAL AT 3 M

FREQ. (MHz)	EMISSION LEVEL (dBuV/m)	READ LEVEL (dBuV)	LIMIT (dBuV/m)	MARGIN (dB)	ANTENNA FACTOR (dB /m)	CABLE LOSS (dB)	PREAMP FACTOR (dB)	ANTENNA HEIGHT (cm)	TABLE ANGLE (Degree)	REMARK
5460	57.73	60.02	74	-16.27	36.48	7.49	46.26	100	28	Peak
5460	44.35	46.64	54	-9.65	36.48	7.49	46.26	100	28	Average
#5470	59.07	61.36	68.3	-9.23	36.48	7.49	46.26	100	28	Peak
5580	101.11	103.21			36.55	7.58	46.23	100	28	Peak
5580	93.28	95.38			36.55	7.58	46.23	100	28	Average

REMARKS:

- Emission Level = Read Level+ Antenna Factor + Cable Loss- Preamp Factor
Margin value = Emission level – Limit value.
- 5580MHz: Fundamental frequency.
- #: Out of restricted band.



CHANNEL	TX Channel 140	DETECTOR FUNCTION	Peak (PK)
FREQUENCY RANGE	1GHz ~ 40GHz		Average (AV)

ANTENNA POLARITY & TEST DISTANCE: HORIZONTAL AT 3 M										
FREQ. (MHz)	EMISSION LEVEL (dBuV/m)	READ LEVEL (dBuV)	LIMIT (dBuV/m)	MARGIN (dB)	ANTENNA FACTOR (dB /m)	CABLE LOSS (dB)	PREAMP FACTOR (dB)	ANTENNA HEIGHT (cm)	TABLE ANGLE (Degree)	REMARK
5700	98.12	100.23			36.38	7.7	46.19	100	142	Peak
5700	90.52	92.63			36.38	7.7	46.19	100	142	Average
#5725	60.32	62.39	68.3	-7.98	36.39	7.73	46.19	100	142	Peak
ANTENNA POLARITY & TEST DISTANCE: VERTICAL AT 3 M										
FREQ. (MHz)	EMISSION LEVEL (dBuV/m)	READ LEVEL (dBuV)	LIMIT (dBuV/m)	MARGIN (dB)	ANTENNA FACTOR (dB /m)	CABLE LOSS (dB)	PREAMP FACTOR (dB)	ANTENNA HEIGHT (cm)	TABLE ANGLE (Degree)	REMARK
5700	100.61	102.48			36.62	7.7	46.19	100	31	Peak
5700	91.74	93.61			36.62	7.7	46.19	100	31	Average
#5725	60.63	62.46	68.3	-7.67	36.63	7.73	46.19	100	31	Peak

REMARKS:

- Emission Level = Read Level+ Antenna Factor + Cable Loss- Preamp Factor
Margin value = Emission level – Limit value.
- 5720MHz: Fundamental frequency.
- #: Out of restricted band.



802.11n (40MHz)

CHANNEL	TX Channel 102	DETECTOR FUNCTION	Peak (PK)
FREQUENCY RANGE	1GHz ~ 40GHz		Average (AV)

ANTENNA POLARITY & TEST DISTANCE: HORIZONTAL AT 3 M

FREQ. (MHz)	EMISSION LEVEL (dBuV/m)	READ LEVEL (dBuV)	LIMIT (dBuV/m)	MARGIN (dB)	ANTENNA FACTOR (dB /m)	CABLE LOSS (dB)	PREAMP FACTOR (dB)	ANTENNA HEIGHT (cm)	TABLE ANGLE (Degree)	REMARK
5460	59.85	62.36	74	-14.15	36.26	7.49	46.26	100	135	Peak
5460	45.72	48.23	54	-8.28	36.26	7.49	46.26	100	135	Average
#5470	60.04	62.54	68.3	-8.26	36.27	7.49	46.26	100	135	Peak
5510	97.81	100.25			36.3	7.51	46.25	100	135	Peak
5510	90.89	93.33			36.3	7.51	46.25	100	135	Average

ANTENNA POLARITY & TEST DISTANCE: VERTICAL AT 3 M

FREQ. (MHz)	EMISSION LEVEL (dBuV/m)	READ LEVEL (dBuV)	LIMIT (dBuV/m)	MARGIN (dB)	ANTENNA FACTOR (dB /m)	CABLE LOSS (dB)	PREAMP FACTOR (dB)	ANTENNA HEIGHT (cm)	TABLE ANGLE (Degree)	REMARK
5460	59.86	62.15	74	-14.14	36.48	7.49	46.26	100	21	Peak
5460	46.6	48.89	54	-7.4	36.48	7.49	46.26	100	21	Average
#5470	61.11	63.4	68.3	-7.19	36.48	7.49	46.26	100	21	Peak
5510	98.4	100.63			36.51	7.51	46.25	100	21	Peak
5510	90.08	92.31			36.51	7.51	46.25	100	21	Average

REMARKS:

- Emission Level = Read Level+ Antenna Factor + Cable Loss- Preamp Factor
Margin value = Emission level – Limit value.
- 5510MHz: Fundamental frequency.
- #: Out of restricted band.



CHANNEL	TX Channel 110	DETECTOR FUNCTION	Peak (PK)
FREQUENCY RANGE	1GHz ~ 40GHz		Average (AV)

ANTENNA POLARITY & TEST DISTANCE: HORIZONTAL AT 3 M

FREQ. (MHz)	EMISSION LEVEL (dBuV/m)	READ LEVEL (dBuV)	LIMIT (dBuV/m)	MARGIN (dB)	ANTENNA FACTOR (dB /m)	CABLE LOSS (dB)	PREAMP FACTOR (dB)	ANTENNA HEIGHT (cm)	TABLE ANGLE (Degree)	REMARK
5460	59.61	62.12	74	-14.39	36.26	7.49	46.26	100	142	Peak
5460	45.8	48.31	54	-8.2	36.26	7.49	46.26	100	142	Average
#5470	60.08	62.58	68.3	-8.22	36.27	7.49	46.26	100	142	Peak
5550	97.89	100.26			36.32	7.55	46.24	100	142	Peak
5550	90.85	93.22			36.32	7.55	46.24	100	142	Average

ANTENNA POLARITY & TEST DISTANCE: VERTICAL AT 3 M

FREQ. (MHz)	EMISSION LEVEL (dBuV/m)	READ LEVEL (dBuV)	LIMIT (dBuV/m)	MARGIN (dB)	ANTENNA FACTOR (dB /m)	CABLE LOSS (dB)	PREAMP FACTOR (dB)	ANTENNA HEIGHT (cm)	TABLE ANGLE (Degree)	REMARK
5460	59.85	62.14	74	-14.15	36.48	7.49	46.26	100	12	Peak
5460	46.32	48.61	54	-7.68	36.48	7.49	46.26	100	12	Average
#5470	60.97	63.26	68.3	-7.33	36.48	7.49	46.26	100	12	Peak
5550	98.29	100.45			36.53	7.55	46.24	100	12	Peak
5550	90.19	92.35			36.53	7.55	46.24	100	12	Average

REMARKS:

- Emission Level = Read Level+ Antenna Factor + Cable Loss- Preamp Factor
Margin value = Emission level – Limit value.
- 5550MHz: Fundamental frequency.
- #: Out of restricted band.



CHANNEL	TX Channel 134	DETECTOR FUNCTION	Peak (PK)
FREQUENCY RANGE	1GHz ~ 40GHz		Average (AV)

ANTENNA POLARITY & TEST DISTANCE: HORIZONTAL AT 3 M										
FREQ. (MHz)	EMISSION LEVEL (dBuV/m)	READ LEVEL (dBuV)	LIMIT (dBuV/m)	MARGIN (dB)	ANTENNA FACTOR (dB /m)	CABLE LOSS (dB)	PREAMP FACTOR (dB)	ANTENNA HEIGHT (cm)	TABLE ANGLE (Degree)	REMARK
5670	97.52	99.68			36.37	7.67	46.2	100	128	Peak
5670	90.18	92.34			36.37	7.67	46.2	100	128	Average
#5725	60.52	62.59	68.3	-7.78	36.39	7.73	46.19	100	128	Peak
ANTENNA POLARITY & TEST DISTANCE: VERTICAL AT 3 M										
FREQ. (MHz)	EMISSION LEVEL (dBuV/m)	READ LEVEL (dBuV)	LIMIT (dBuV/m)	MARGIN (dB)	ANTENNA FACTOR (dB /m)	CABLE LOSS (dB)	PREAMP FACTOR (dB)	ANTENNA HEIGHT (cm)	TABLE ANGLE (Degree)	REMARK
5670	98.3	100.23			36.6	7.67	46.2	100	25	Peak
5670	90.43	92.36			36.6	7.67	46.2	100	25	Average
#5725	61.39	63.22	68.3	-6.91	36.63	7.73	46.19	100	25	Peak

REMARKS:

- Emission Level = Read Level+ Antenna Factor + Cable Loss- Preamp Factor
Margin value = Emission level – Limit value.
- 5670MHz: Fundamental frequency.
- #: Out of restricted band.



802.11ac (80MHz)

CHANNEL	TX Channel 106	DETECTOR FUNCTION	Peak (PK)
FREQUENCY RANGE	1GHz ~ 40GHz		Average (AV)

ANTENNA POLARITY & TEST DISTANCE: HORIZONTAL AT 3 M

FREQ. (MHz)	EMISSION LEVEL (dBuV/m)	READ LEVEL (dBuV)	LIMIT (dBuV/m)	MARGIN (dB)	ANTENNA FACTOR (dB /m)	CABLE LOSS (dB)	PREAMP FACTOR (dB)	ANTENNA HEIGHT (cm)	TABLE ANGLE (Degree)	REMARK
5460	61.08	63.59	74	-12.92	36.26	7.49	46.26	100	132	Peak
5460	47.36	49.87	54	-6.64	36.26	7.49	46.26	100	132	Average
#5470	61.37	63.87	68.3	-6.93	36.27	7.49	46.26	100	132	Peak
5530	96.24	98.64			36.31	7.53	46.24	100	132	Peak
5530	88.83	91.23			36.31	7.53	46.24	100	132	Average

ANTENNA POLARITY & TEST DISTANCE: VERTICAL AT 3 M

FREQ. (MHz)	EMISSION LEVEL (dBuV/m)	READ LEVEL (dBuV)	LIMIT (dBuV/m)	MARGIN (dB)	ANTENNA FACTOR (dB /m)	CABLE LOSS (dB)	PREAMP FACTOR (dB)	ANTENNA HEIGHT (cm)	TABLE ANGLE (Degree)	REMARK
5460	60.3	62.59	74	-13.7	36.48	7.49	46.26	100	16	Peak
5460	47.49	49.78	54	-6.51	36.48	7.49	46.26	100	16	Average
#5470	61.26	63.55	68.3	-7.04	36.48	7.49	46.26	100	16	Peak
5530	98.05	100.24			36.52	7.53	46.24	100	16	Peak
5530	90.46	92.65			36.52	7.53	46.24	100	16	Average

REMARKS:

- Emission Level = Read Level+ Antenna Factor + Cable Loss- Preamp Factor
Margin value = Emission level – Limit value.
- 5530MHz: Fundamental frequency.
- #: Out of restricted band.



Band 4:

802.11a

CHANNEL	TX Channel 149	DETECTOR FUNCTION	Peak (PK)
FREQUENCY RANGE	1GHz ~ 40GHz		Average (AV)

ANTENNA POLARITY & TEST DISTANCE: HORIZONTAL AT 3 M										
FREQ. (MHz)	EMISSION LEVEL (dBuV/m)	READ LEVEL (dBuV)	LIMIT (dBuV/m)	MARGIN (dB)	ANTENNA FACTOR (dB /m)	CABLE LOSS (dB)	PREAMP FACTOR (dB)	ANTENNA HEIGHT (cm)	TABLE ANGLE (Degree)	REMARK
5745	102.68	103.56			37.55	7.75	46.18	100	135	Peak
5745	92.37	93.25			37.55	7.75	46.18	100	135	Average
ANTENNA POLARITY & TEST DISTANCE: VERTICAL AT 3 M										
FREQ. (MHz)	EMISSION LEVEL (dBuV/m)	READ LEVEL (dBuV)	LIMIT (dBuV/m)	MARGIN (dB)	ANTENNA FACTOR (dB /m)	CABLE LOSS (dB)	PREAMP FACTOR (dB)	ANTENNA HEIGHT (cm)	TABLE ANGLE (Degree)	REMARK
5745	104.35	105.23			37.55	7.75	46.18	100	21	Peak
5745	94.53	95.41			37.55	7.75	46.18	100	21	Average

REMARKS:

1. Emission Level = Read Level+ Antenna Factor + Cable Loss- Preamp Factor
Margin value = Emission level – Limit value.
2. 5745MHz: Fundamental frequency.



Oobe Data

802.11a

ANTENNA POLARITY & TEST DISTANCE: HORIZONTAL AT 3 M										
FREQ. (MHz)	EMISSION LEVEL (dBuV/m)	READ LEVEL (dBuV)	LIMIT (dBuV/m)	MARGIN (dB)	ANTENNA FACTOR (dB /m)	CABLE LOSS (dB)	PREAMP FACTOR (dB)	ANTENNA HEIGHT (cm)	TABLE ANGLE (Degree)	REMARK
5580.875	56.29	58.61	68.3	-12.01	36.33	7.58	46.23	100	0	Peak
5964.2	57.26	58.92	68.3	-11.04	36.49	7.97	46.12	100	0	Peak
ANTENNA POLARITY & TEST DISTANCE: VERTICAL AT 3 M										
FREQ. (MHz)	EMISSION LEVEL (dBuV/m)	READ LEVEL (dBuV)	LIMIT (dBuV/m)	MARGIN (dB)	ANTENNA FACTOR (dB /m)	CABLE LOSS (dB)	PREAMP FACTOR (dB)	ANTENNA HEIGHT (cm)	TABLE ANGLE (Degree)	REMARK
5592.275	57.39	59.46	68.3	-10.91	36.56	7.59	46.22	100	0	Peak
5957.55	57.76	59.14	68.3	-10.54	36.77	7.97	46.12	100	0	Peak

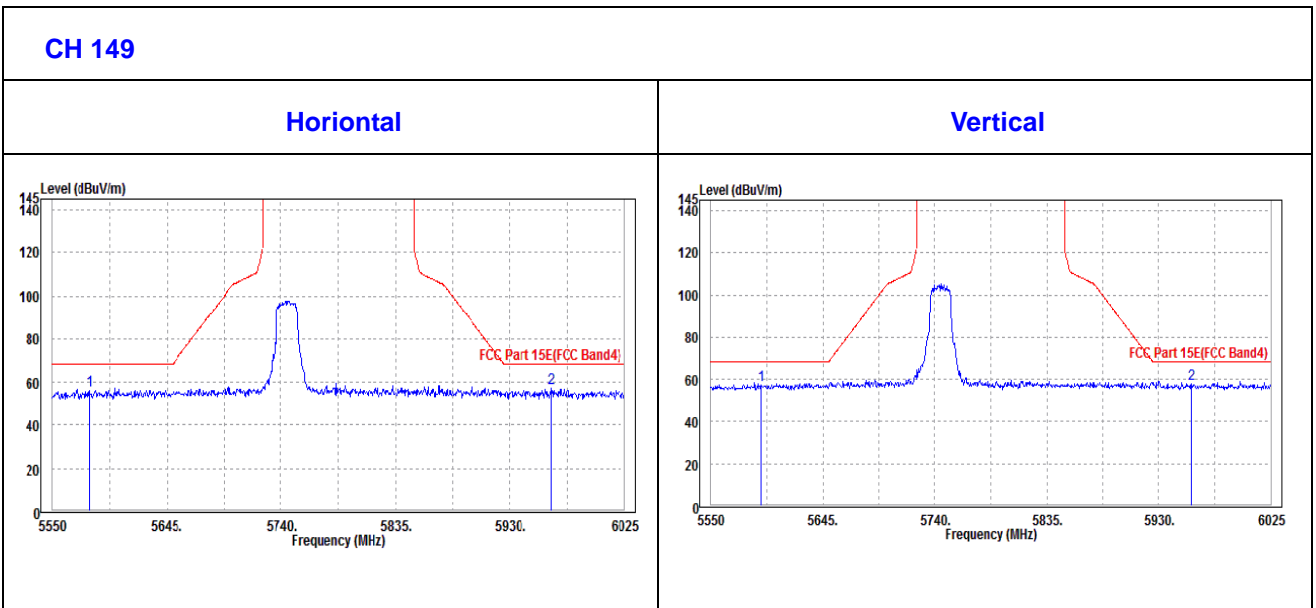



CHANNEL	TX Channel 157	DETECTOR FUNCTION	Peak (PK)
FREQUENCY RANGE	1GHz ~ 40GHz		Average (AV)

ANTENNA POLARITY & TEST DISTANCE: HORIZONTAL AT 3 M

FREQ. (MHz)	EMISSION LEVEL (dBuV/m)	READ LEVEL (dBuV)	LIMIT (dBuV/m)	MARGIN (dB)	ANTENNA FACTOR (dB /m)	CABLE LOSS (dB)	PREAMP FACTOR (dB)	ANTENNA HEIGHT (cm)	TABLE ANGLE (Degree)	REMARK
5785	102.44	103.25			37.57	7.79	46.17	100	65	Peak
5785	91.87	92.68			37.57	7.79	46.17	100	63	Average

ANTENNA POLARITY & TEST DISTANCE: VERTICAL AT 3 M

FREQ. (MHz)	EMISSION LEVEL (dBuV/m)	READ LEVEL (dBuV)	LIMIT (dBuV/m)	MARGIN (dB)	ANTENNA FACTOR (dB /m)	CABLE LOSS (dB)	PREAMP FACTOR (dB)	ANTENNA HEIGHT (cm)	TABLE ANGLE (Degree)	REMARK
5785	104.5	106.21			36.67	7.79	46.17	100	45	Peak
5785	93.63	95.34			36.67	7.79	46.17	100	45	Average

REMARKS:

- Emission Level = Read Level+ Antenna Factor + Cable Loss- Preamp Factor
Margin value = Emission level – Limit value.
- 5785MHz: Fundamental frequency.



**BUREAU
VERITAS**

Test Report No.: RF190712W002

Oobe Data

802.11a

ANTENNA POLARITY & TEST DISTANCE: HORIZONTAL AT 3 M										
FREQ. (MHz)	EMISSION LEVEL (dBuV/m)	READ LEVEL (dBuV)	LIMIT (dBuV/m)	MARGIN (dB)	ANTENNA FACTOR (dB /m)	CABLE LOSS (dB)	PREAMP FACTOR (dB)	ANTENNA HEIGHT (cm)	TABLE ANGLE (Degree)	REMARK
5587.05	55.37	57.68	68.3	-12.93	36.33	7.59	46.23	100	0	Peak
5938.55	58.26	59.96	68.3	-10.04	36.48	7.95	46.13	100	0	Peak
ANTENNA POLARITY & TEST DISTANCE: VERTICAL AT 3 M										
FREQ. (MHz)	EMISSION LEVEL (dBuV/m)	READ LEVEL (dBuV)	LIMIT (dBuV/m)	MARGIN (dB)	ANTENNA FACTOR (dB /m)	CABLE LOSS (dB)	PREAMP FACTOR (dB)	ANTENNA HEIGHT (cm)	TABLE ANGLE (Degree)	REMARK
5592.75	57.24	59.31	68.3	-11.06	36.56	7.59	46.22	100	87	Peak
5958.5	58.54	59.91	68.3	-9.76	36.78	7.97	46.12	100	87	Peak

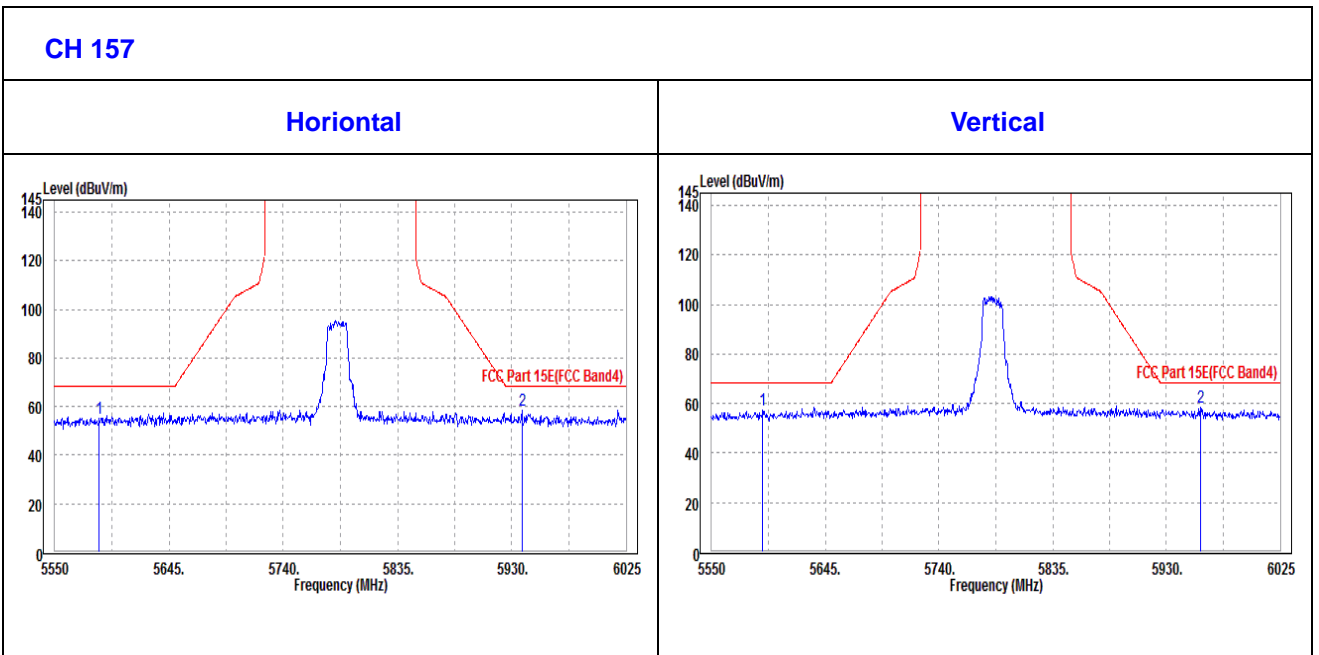



CHANNEL	TX Channel 161	DETECTOR FUNCTION	Peak (PK)
FREQUENCY RANGE	1GHz ~ 40GHz		Average (AV)

ANTENNA POLARITY & TEST DISTANCE: HORIZONTAL AT 3 M

FREQ. (MHz)	EMISSION LEVEL (dBuV/m)	READ LEVEL (dBuV)	LIMIT (dBuV/m)	MARGIN (dB)	ANTENNA FACTOR (dB /m)	CABLE LOSS (dB)	PREAMP FACTOR (dB)	ANTENNA HEIGHT (cm)	TABLE ANGLE (Degree)	REMARK
5805	103.74	104.51			37.58	7.81	46.16	100	135	Peak
5805	92.46	93.23			37.58	7.81	46.16	100	135	Average

ANTENNA POLARITY & TEST DISTANCE: VERTICAL AT 3 M

FREQ. (MHz)	EMISSION LEVEL (dBuV/m)	READ LEVEL (dBuV)	LIMIT (dBuV/m)	MARGIN (dB)	ANTENNA FACTOR (dB /m)	CABLE LOSS (dB)	PREAMP FACTOR (dB)	ANTENNA HEIGHT (cm)	TABLE ANGLE (Degree)	REMARK
5805	104.86	105.63			37.58	7.81	46.16	100	0	Peak
5805	94.68	95.45			37.58	7.81	46.16	100	0	Average

REMARKS:

- Emission Level = Read Level+ Antenna Factor + Cable Loss- Preamp Factor
Margin value = Emission level – Limit value.
- 5805MHz: Fundamental frequency.



OUBE DATA

802.11a

ANTENNA POLARITY & TEST DISTANCE: HORIZONTAL AT 3 M										
FREQ. (MHz)	EMISSION LEVEL (dBuV/m)	READ LEVEL (dBuV)	LIMIT (dBuV/m)	MARGIN (dB)	ANTENNA FACTOR (dB /m)	CABLE LOSS (dB)	PREAMP FACTOR (dB)	ANTENNA HEIGHT (cm)	TABLE ANGLE (Degree)	REMARK
5598.925	57.05	59.33	68.3	-11.25	36.34	7.6	46.22	100	0	Peak
5947.575	57.53	59.21	68.3	-10.77	36.48	7.96	46.12	100	0	Peak
ANTENNA POLARITY & TEST DISTANCE: VERTICAL AT 3 M										
FREQ. (MHz)	EMISSION LEVEL (dBuV/m)	READ LEVEL (dBuV)	LIMIT (dBuV/m)	MARGIN (dB)	ANTENNA FACTOR (dB /m)	CABLE LOSS (dB)	PREAMP FACTOR (dB)	ANTENNA HEIGHT (cm)	TABLE ANGLE (Degree)	REMARK
5574.7	55.17	57.28	68.3	-13.13	36.54	7.58	46.23	100	87	Peak
5966.575	55.63	56.99	68.3	-12.67	36.78	7.98	46.12	100	87	Peak

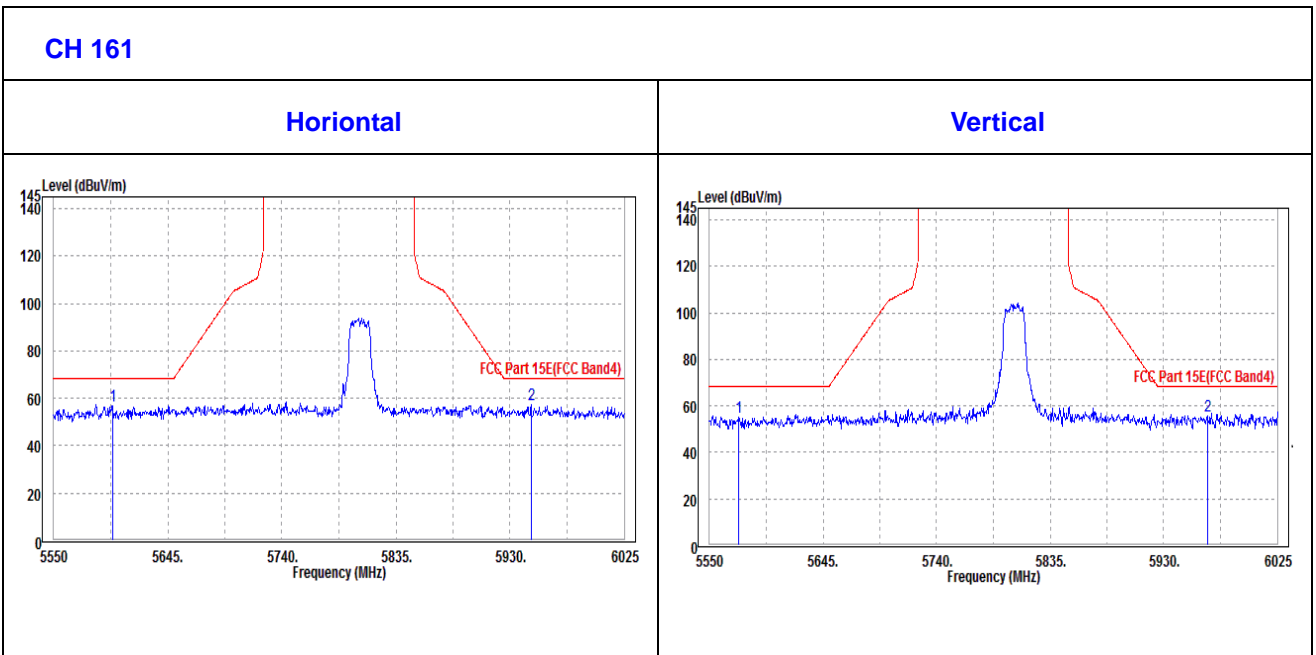



802.11n (20MHz)

CHANNEL	TX Channel 149	DETECTOR FUNCTION	Peak (PK)
FREQUENCY RANGE	1GHz ~ 40GHz		Average (AV)

ANTENNA POLARITY & TEST DISTANCE: HORIZONTAL AT 3 M										
FREQ. (MHz)	EMISSION LEVEL (dBuV/m)	READ LEVEL (dBuV)	LIMIT (dBuV/m)	MARGIN (dB)	ANTENNA FACTOR (dB /m)	CABLE LOSS (dB)	PREAMP FACTOR (dB)	ANTENNA HEIGHT (cm)	TABLE ANGLE (Degree)	REMARK
5745	100.77	101.65			37.55	7.75	46.18	100	136	Peak
5745	90.14	91.02			37.55	7.75	46.18	100	136	Average
ANTENNA POLARITY & TEST DISTANCE: VERTICAL AT 3 M										
FREQ. (MHz)	EMISSION LEVEL (dBuV/m)	READ LEVEL (dBuV)	LIMIT (dBuV/m)	MARGIN (dB)	ANTENNA FACTOR (dB /m)	CABLE LOSS (dB)	PREAMP FACTOR (dB)	ANTENNA HEIGHT (cm)	TABLE ANGLE (Degree)	REMARK
5745	101.81	102.69			37.55	7.75	46.18	100	75	Peak
5745	91.33	92.21			37.55	7.75	46.18	100	75	Average

REMARKS:

- Emission Level = Read Level+ Antenna Factor + Cable Loss- Preamp Factor
Margin value = Emission level – Limit value.
- 5745MHz: Fundamental frequency.



OUBE DATA

802.11n (20MHZ)

ANTENNA POLARITY & TEST DISTANCE: HORIZONTAL AT 3 M										
FREQ. (MHz)	EMISSION LEVEL (dBuV/m)	READ LEVEL (dBuV)	LIMIT (dBuV/m)	MARGIN (dB)	ANTENNA FACTOR (dB /m)	CABLE LOSS (dB)	PREAMP FACTOR (dB)	ANTENNA HEIGHT (cm)	TABLE ANGLE (Degree)	REMARK
5597.025	55.11	57.39	68.3	-13.19	36.34	7.6	46.22	100	0	Peak
5958.025	56.51	58.18	68.3	-11.79	36.48	7.97	46.12	100	0	Peak
ANTENNA POLARITY & TEST DISTANCE: VERTICAL AT 3 M										
FREQ. (MHz)	EMISSION LEVEL (dBuV/m)	READ LEVEL (dBuV)	LIMIT (dBuV/m)	MARGIN (dB)	ANTENNA FACTOR (dB /m)	CABLE LOSS (dB)	PREAMP FACTOR (dB)	ANTENNA HEIGHT (cm)	TABLE ANGLE (Degree)	REMARK
5577.55	57.31	59.41	68.3	-10.99	36.55	7.58	46.23	100	74	Peak
5963.25	57.45	58.82	68.3	-10.85	36.78	7.97	46.12	100	74	Peak

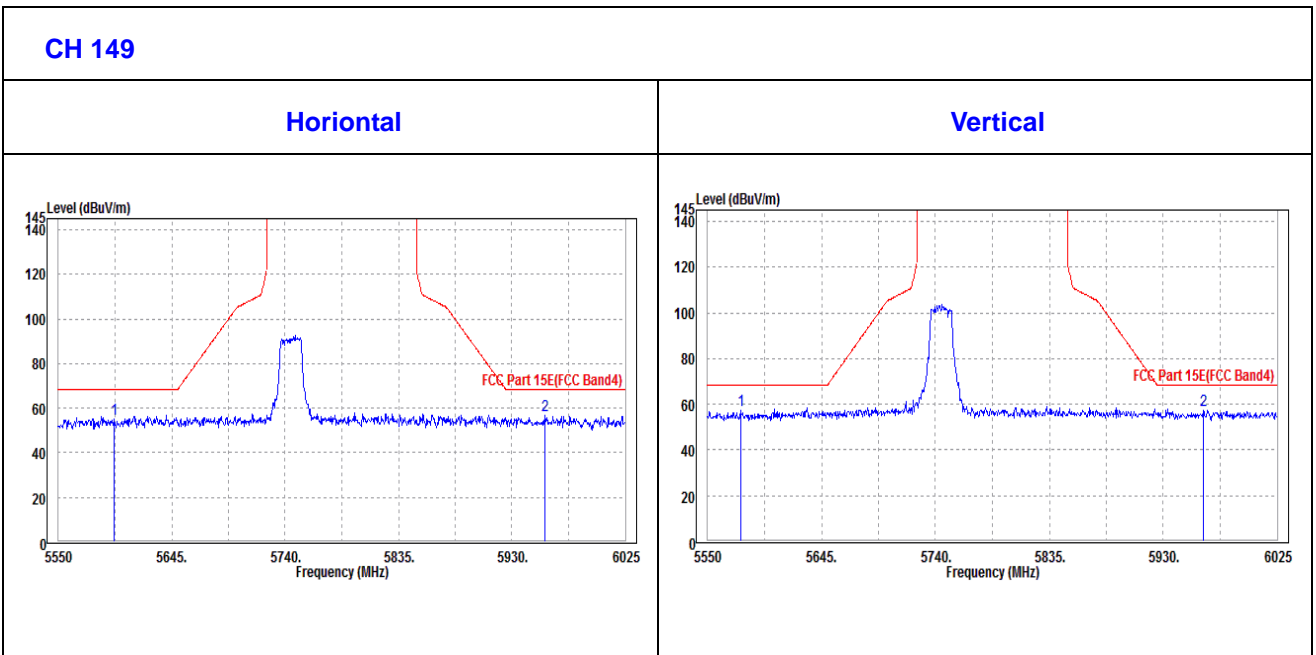



CHANNEL	TX Channel 157	DETECTOR FUNCTION	Peak (PK)
FREQUENCY RANGE	1GHz ~ 40GHz		Average (AV)

ANTENNA POLARITY & TEST DISTANCE: HORIZONTAL AT 3 M

FREQ. (MHz)	EMISSION LEVEL (dBuV/m)	READ LEVEL (dBuV)	LIMIT (dBuV/m)	MARGIN (dB)	ANTENNA FACTOR (dB /m)	CABLE LOSS (dB)	PREAMP FACTOR (dB)	ANTENNA HEIGHT (cm)	TABLE ANGLE (Degree)	REMARK
5785	99.87	100.68			37.57	7.79	46.17	100	145	Peak
5785	90.23	91.04			37.57	7.79	46.17	100	145	Average

ANTENNA POLARITY & TEST DISTANCE: VERTICAL AT 3 M

FREQ. (MHz)	EMISSION LEVEL (dBuV/m)	READ LEVEL (dBuV)	LIMIT (dBuV/m)	MARGIN (dB)	ANTENNA FACTOR (dB /m)	CABLE LOSS (dB)	PREAMP FACTOR (dB)	ANTENNA HEIGHT (cm)	TABLE ANGLE (Degree)	REMARK
5785	101.57	103.28			36.67	7.79	46.17	100	25	Peak
5785	91.93	93.64			36.67	7.79	46.17	100	25	Average

REMARKS:

- Emission Level = Read Level+ Antenna Factor + Cable Loss- Preamp Factor
Margin value = Emission level – Limit value.
- 5785MHz: Fundamental frequency.



OBE DATA

802.11n (20MHZ)

ANTENNA POLARITY & TEST DISTANCE: HORIZONTAL AT 3 M										
FREQ. (MHz)	EMISSION LEVEL (dBuV/m)	READ LEVEL (dBuV)	LIMIT (dBuV/m)	MARGIN (dB)	ANTENNA FACTOR (dB /m)	CABLE LOSS (dB)	PREAMP FACTOR (dB)	ANTENNA HEIGHT (cm)	TABLE ANGLE (Degree)	REMARK
5575.65	55.67	57.99	68.3	-12.63	36.33	7.58	46.23	100	0	Peak
5962.3	56.76	58.43	68.3	-11.54	36.48	7.97	46.12	100	0	Peak
ANTENNA POLARITY & TEST DISTANCE: VERTICAL AT 3 M										
FREQ. (MHz)	EMISSION LEVEL (dBuV/m)	READ LEVEL (dBuV)	LIMIT (dBuV/m)	MARGIN (dB)	ANTENNA FACTOR (dB /m)	CABLE LOSS (dB)	PREAMP FACTOR (dB)	ANTENNA HEIGHT (cm)	TABLE ANGLE (Degree)	REMARK
5590.37 5	57.27	59.35	68.3	-11.03	36.55	7.59	46.22	100	74	Peak
5968.95	56.34	57.7	68.3	-11.96	36.78	7.98	46.12	100	74	Peak

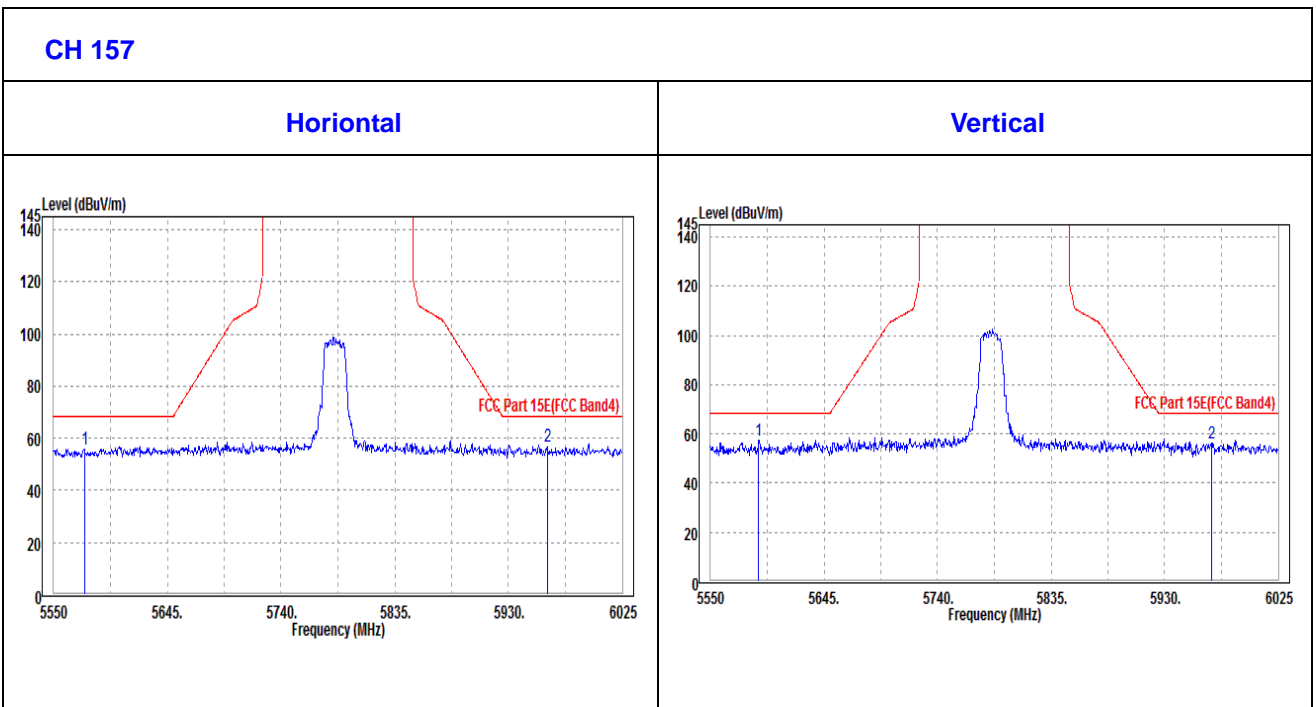



CHANNEL	TX Channel 161	DETECTOR FUNCTION	Peak (PK)
FREQUENCY RANGE	1GHz ~ 40GHz		Average (AV)

ANTENNA POLARITY & TEST DISTANCE: HORIZONTAL AT 3 M

FREQ. (MHz)	EMISSION LEVEL (dBuV/m)	READ LEVEL (dBuV)	LIMIT (dBuV/m)	MARGIN (dB)	ANTENNA FACTOR (dB /m)	CABLE LOSS (dB)	PREAMP FACTOR (dB)	ANTENNA HEIGHT (cm)	TABLE ANGLE (Degree)	REMARK
5805	100.98	101.75			37.58	7.81	46.16	100	0	Peak
5805	90.47	91.24			37.58	7.81	46.16	100	0	Average

ANTENNA POLARITY & TEST DISTANCE: VERTICAL AT 3 M

FREQ. (MHz)	EMISSION LEVEL (dBuV/m)	READ LEVEL (dBuV)	LIMIT (dBuV/m)	MARGIN (dB)	ANTENNA FACTOR (dB /m)	CABLE LOSS (dB)	PREAMP FACTOR (dB)	ANTENNA HEIGHT (cm)	TABLE ANGLE (Degree)	REMARK
5805	101.58	102.35			37.58	7.81	46.16	100	35	Peak
5805	91.59	92.36			37.58	7.81	46.16	100	35	Average

REMARKS:

- Emission Level = Read Level+ Antenna Factor + Cable Loss- Preamp Factor
Margin value = Emission level – Limit value.
- 5805MHz: Fundamental frequency.



OUBE DATA

802.11n (20MHZ)

ANTENNA POLARITY & TEST DISTANCE: HORIZONTAL AT 3 M										
FREQ. (MHz)	EMISSION LEVEL (dBuV/m)	READ LEVEL (dBuV)	LIMIT (dBuV/m)	MARGIN (dB)	ANTENNA FACTOR (dB /m)	CABLE LOSS (dB)	PREAMP FACTOR (dB)	ANTENNA HEIGHT (cm)	TABLE ANGLE (Degree)	REMARK
5565.675	55.13	57.46	68.3	-13.17	36.33	7.57	46.23	100	0	Peak
5994.6	55.14	56.75	68.3	-13.16	36.5	8	46.11	100	0	Peak
ANTENNA POLARITY & TEST DISTANCE: VERTICAL AT 3 M										
FREQ. (MHz)	EMISSION LEVEL (dBuV/m)	READ LEVEL (dBuV)	LIMIT (dBuV/m)	MARGIN (dB)	ANTENNA FACTOR (dB /m)	CABLE LOSS (dB)	PREAMP FACTOR (dB)	ANTENNA HEIGHT (cm)	TABLE ANGLE (Degree)	REMARK
5581.825	56.12	58.22	68.3	-12.18	36.55	7.58	46.23	100	91	Peak
5958.5	57.32	58.69	68.3	-10.98	36.78	7.97	46.12	100	91	Peak

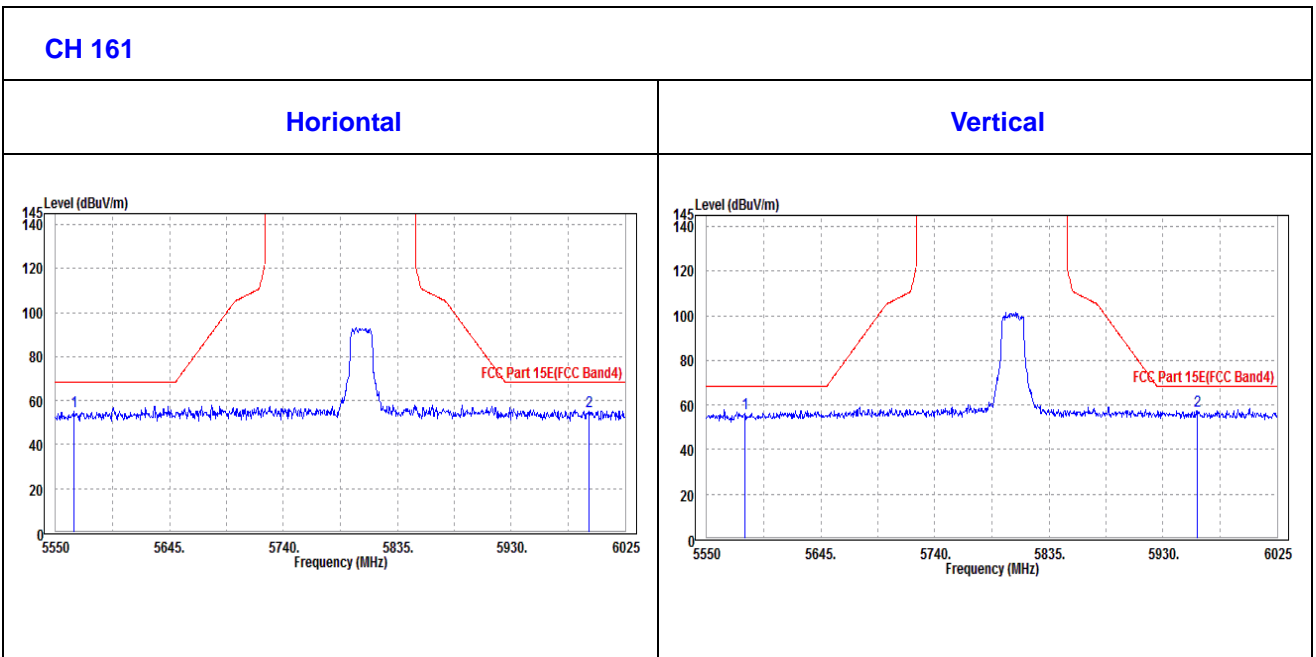



802.11n (40MHz)

CHANNEL	TX Channel 151	DETECTOR FUNCTION	Peak (PK)
FREQUENCY RANGE	1GHz ~ 40GHz		Average (AV)

ANTENNA POLARITY & TEST DISTANCE: HORIZONTAL AT 3 M										
FREQ. (MHz)	EMISSION LEVEL (dBuV/m)	READ LEVEL (dBuV)	LIMIT (dBuV/m)	MARGIN (dB)	ANTENNA FACTOR (dB /m)	CABLE LOSS (dB)	PREAMP FACTOR (dB)	ANTENNA HEIGHT (cm)	TABLE ANGLE (Degree)	REMARK
5755	98.54	99.41			37.55	7.76	46.18	100	138	Peak
5755	88.76	89.63			37.55	7.76	46.18	100	138	Average
ANTENNA POLARITY & TEST DISTANCE: VERTICAL AT 3 M										
FREQ. (MHz)	EMISSION LEVEL (dBuV/m)	READ LEVEL (dBuV)	LIMIT (dBuV/m)	MARGIN (dB)	ANTENNA FACTOR (dB /m)	CABLE LOSS (dB)	PREAMP FACTOR (dB)	ANTENNA HEIGHT (cm)	TABLE ANGLE (Degree)	REMARK
5755	98.81	100.58			36.65	7.76	46.18	100	62	Peak
5755	88.46	90.23			36.65	7.76	46.18	100	62	Average

REMARKS:

1. Emission Level = Read Level+ Antenna Factor + Cable Loss- Preamp Factor
Margin value = Emission level – Limit value.
2. 5755MHz: Fundamental frequency.



Oobe Data

802.11n (40MHz)

ANTENNA POLARITY & TEST DISTANCE: HORIZONTAL AT 3 M										
FREQ. (MHz)	EMISSION LEVEL (dBuV/m)	READ LEVEL (dBuV)	LIMIT (dBuV/m)	MARGIN (dB)	ANTENNA FACTOR (dB /m)	CABLE LOSS (dB)	PREAMP FACTOR (dB)	ANTENNA HEIGHT (cm)	TABLE ANGLE (Degree)	REMARK
5569.475	57.01	59.34	68.3	-11.29	36.33	7.57	46.23	100	0	Peak
5958.025	56.49	58.16	68.3	-11.81	36.48	7.97	46.12	100	0	Peak
ANTENNA POLARITY & TEST DISTANCE: VERTICAL AT 3 M										
FREQ. (MHz)	EMISSION LEVEL (dBuV/m)	READ LEVEL (dBuV)	LIMIT (dBuV/m)	MARGIN (dB)	ANTENNA FACTOR (dB /m)	CABLE LOSS (dB)	PREAMP FACTOR (dB)	ANTENNA HEIGHT (cm)	TABLE ANGLE (Degree)	REMARK
5589.9	56.51	58.59	68.3	-11.79	36.55	7.59	46.22	100	91	Peak
5954.7	56.88	58.27	68.3	-11.42	36.77	7.96	46.12	100	91	Peak

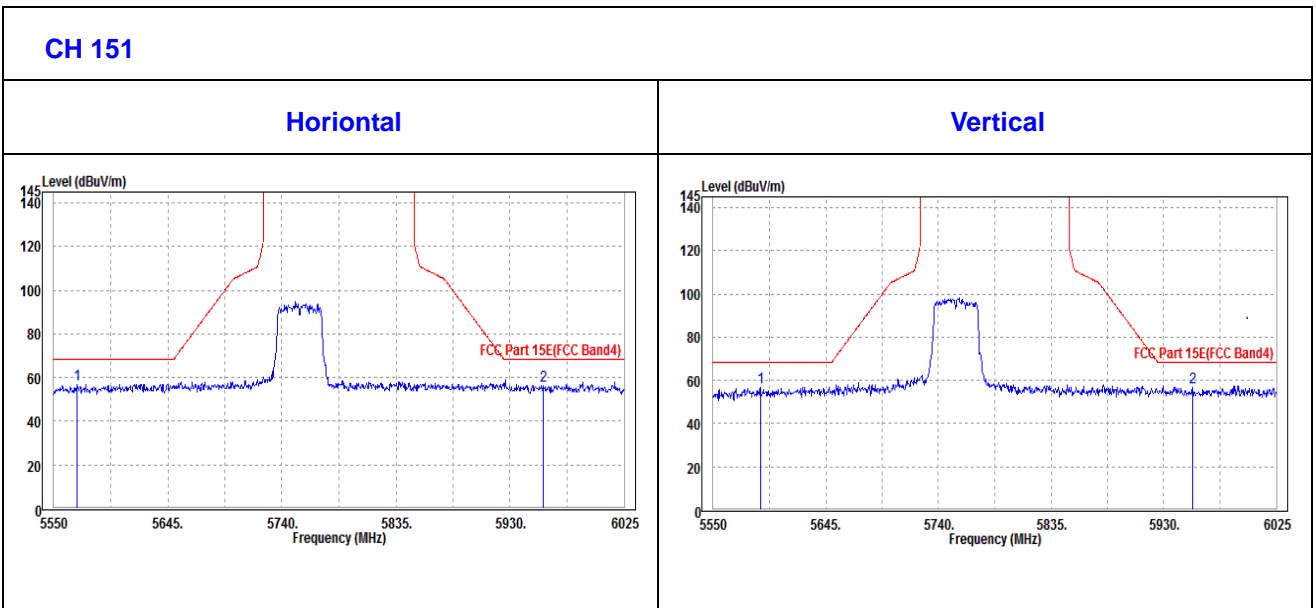



CHANNEL	TX Channel 159	DETECTOR FUNCTION	Peak (PK)
FREQUENCY RANGE	1GHz ~ 40GHz		Average (AV)

ANTENNA POLARITY & TEST DISTANCE: HORIZONTAL AT 3 M

FREQ. (MHz)	EMISSION LEVEL (dBuV/m)	READ LEVEL (dBuV)	LIMIT (dBuV/m)	MARGIN (dB)	ANTENNA FACTOR (dB /m)	CABLE LOSS (dB)	PREAMP FACTOR (dB)	ANTENNA HEIGHT (cm)	TABLE ANGLE (Degree)	REMARK
5795	94.85	95.64			37.58	7.8	46.17	100	126	Peak
5795	85.73	86.52			37.58	7.8	46.17	100	126	Average

ANTENNA POLARITY & TEST DISTANCE: VERTICAL AT 3 M

FREQ. (MHz)	EMISSION LEVEL (dBuV/m)	READ LEVEL (dBuV)	LIMIT (dBuV/m)	MARGIN (dB)	ANTENNA FACTOR (dB /m)	CABLE LOSS (dB)	PREAMP FACTOR (dB)	ANTENNA HEIGHT (cm)	TABLE ANGLE (Degree)	REMARK
5795	97.57	98.36			37.58	7.8	46.17	100	325	Peak
5795	87.88	88.67			37.58	7.8	46.17	100	325	Average

REMARKS:

- Emission Level = Read Level+ Antenna Factor + Cable Loss- Preamp Factor
Margin value = Emission level – Limit value.
- 5795MHz: Fundamental frequency.



OUBE DATA

802.11n (40MHZ)

ANTENNA POLARITY & TEST DISTANCE: HORIZONTAL AT 3 M										
FREQ. (MHz)	EMISSION LEVEL (dBuV/m)	READ LEVEL (dBuV)	LIMIT (dBuV/m)	MARGIN (dB)	ANTENNA FACTOR (dB /m)	CABLE LOSS (dB)	PREAMP FACTOR (dB)	ANTENNA HEIGHT (cm)	TABLE ANGLE (Degree)	REMARK
5572.8	56.41	58.74	68.3	-11.89	36.33	7.57	46.23	100	360	Peak
5971.8	57.1	58.75	68.3	-11.2	36.49	7.98	46.12	100	360	Peak
ANTENNA POLARITY & TEST DISTANCE: VERTICAL AT 3 M										
FREQ. (MHz)	EMISSION LEVEL (dBuV/m)	READ LEVEL (dBuV)	LIMIT (dBuV/m)	MARGIN (dB)	ANTENNA FACTOR (dB /m)	CABLE LOSS (dB)	PREAMP FACTOR (dB)	ANTENNA HEIGHT (cm)	TABLE ANGLE (Degree)	REMARK
5573.275	57.56	59.68	68.3	-10.74	36.54	7.57	46.23	100	0	Peak
5950.9	58.3	59.69	68.3	-10	36.77	7.96	46.12	100	0	Peak

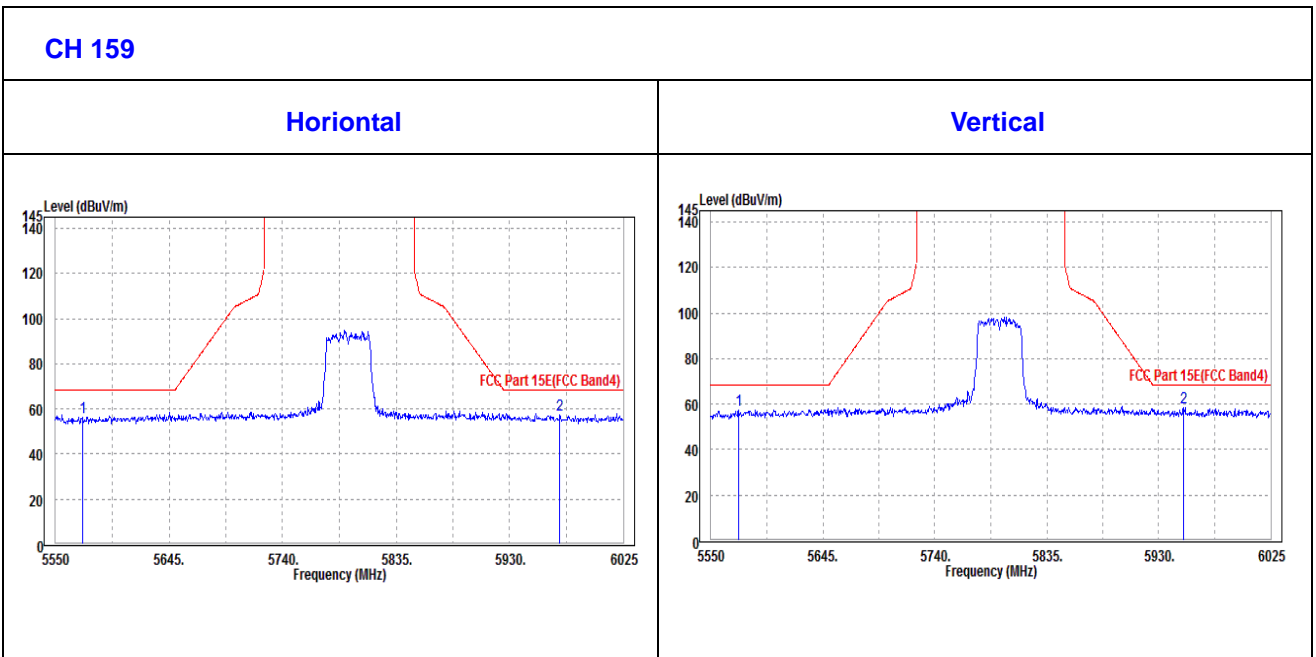



802.11ac (80MHz)

CHANNEL	TX Channel 155	DETECTOR FUNCTION	Peak (PK)
FREQUENCY RANGE	1GHz ~ 40GHz		Average (AV)

ANTENNA POLARITY & TEST DISTANCE: HORIZONTAL AT 3 M										
FREQ. (MHz)	EMISSION LEVEL (dBuV/m)	READ LEVEL (dBuV)	LIMIT (dBuV/m)	MARGIN (dB)	ANTENNA FACTOR (dB /m)	CABLE LOSS (dB)	PREAMP FACTOR (dB)	ANTENNA HEIGHT (cm)	TABLE ANGLE (Degree)	REMARK
5775	93.52	94.34			37.57	7.78	46.17	100	148	Peak
5775	83.68	84.5			37.57	7.78	46.17	100	148	Average
ANTENNA POLARITY & TEST DISTANCE: VERTICAL AT 3 M										
FREQ. (MHz)	EMISSION LEVEL (dBuV/m)	READ LEVEL (dBuV)	LIMIT (dBuV/m)	MARGIN (dB)	ANTENNA FACTOR (dB /m)	CABLE LOSS (dB)	PREAMP FACTOR (dB)	ANTENNA HEIGHT (cm)	TABLE ANGLE (Degree)	REMARK
5775	93.91	95.63			36.67	7.78	46.17	100	12	Peak
5775	83.5	85.22			36.67	7.78	46.17	100	12	Average

REMARKS:

1. Emission Level = Read Level+ Antenna Factor + Cable Loss- Preamp Factor
Margin value = Emission level – Limit value.
2. 5775MHz: Fundamental frequency.



OBE DATA

802.11ac (80MHZ)

ANTENNA POLARITY & TEST DISTANCE: HORIZONTAL AT 3 M										
FREQ. (MHz)	EMISSION LEVEL (dBuV/m)	READ LEVEL (dBuV)	LIMIT (dBuV/m)	MARGIN (dB)	ANTENNA FACTOR (dB /m)	CABLE LOSS (dB)	PREAMP FACTOR (dB)	ANTENNA HEIGHT (cm)	TABLE ANGLE (Degree)	REMARK
5584.2	57.37	59.68	68.3	-10.93	36.33	7.59	46.23	100	360	Peak
5970.85	57.13	58.78	68.3	-11.17	36.49	7.98	46.12	100	360	Peak
ANTENNA POLARITY & TEST DISTANCE: VERTICAL AT 3 M										
FREQ. (MHz)	EMISSION LEVEL (dBuV/m)	READ LEVEL (dBuV)	LIMIT (dBuV/m)	MARGIN (dB)	ANTENNA FACTOR (dB /m)	CABLE LOSS (dB)	PREAMP FACTOR (dB)	ANTENNA HEIGHT (cm)	TABLE ANGLE (Degree)	REMARK
5573.75	56.82	58.93	68.3	-11.48	36.54	7.58	46.23	100	117	Peak
5974.175	57.08	58.44	68.3	-11.22	36.78	7.98	46.12	100	117	Peak

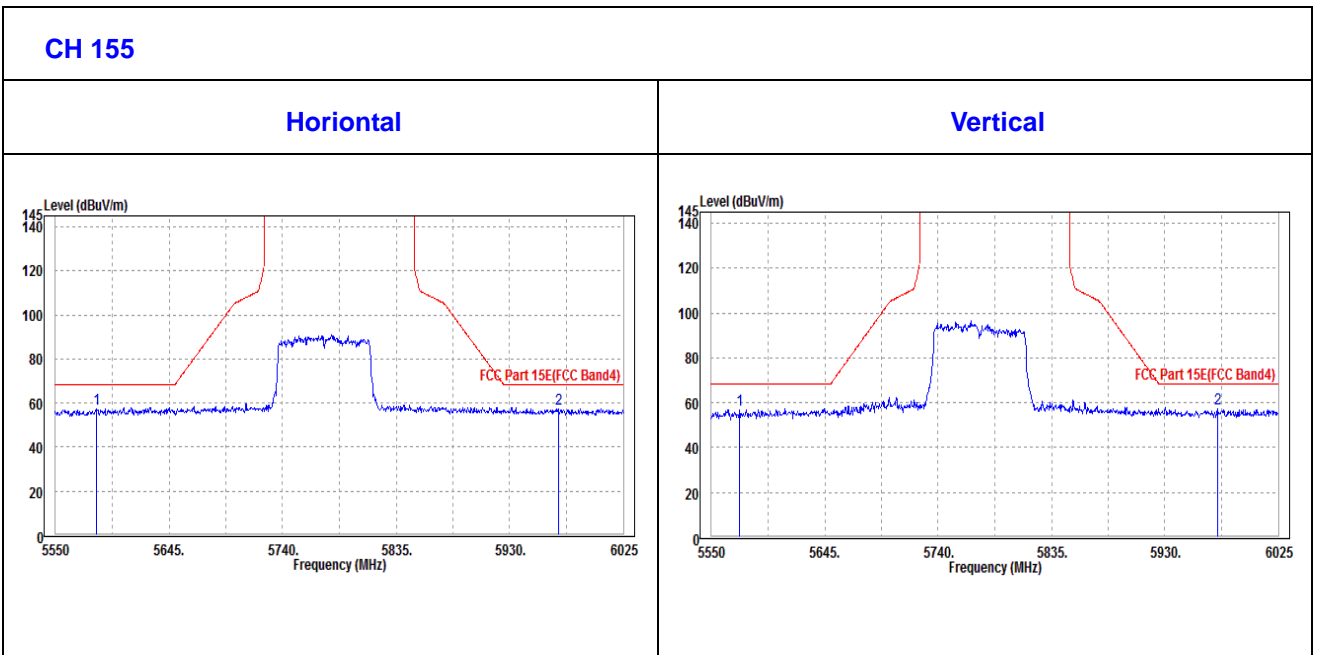



3.2 CONDUCTED EMISSION MEASUREMENT

3.2.1 LIMITS OF CONDUCTED EMISSION MEASUREMENT

FREQUENCY OF EMISSION (MHz)	CONDUCTED LIMIT (dBµV)	
	Quasi-peak	Average
0.15 ~ 0.5	66 to 56	56 to 46
0.5 ~ 5	56	46
5 ~ 30	60	50

- NOTE:**
1. The lower limit shall apply at the transition frequencies.
 2. The limit decreases in line with the logarithm of the frequency in the range of 0.15 to 0.50MHz.
 3. All emanations from a class A/B digital device or system, including any network of conductors and apparatus connected thereto, shall not exceed the level of field strengths specified above.

3.2.2 TEST INSTRUMENTS

Equipment	Manufacturer	Model No.	Serial No.	Last Cal.	Next Cal.
EMI Test Receiver	Rohde&Schwarz	ESR3	101900	Feb. 26,19	Feb. 25,20
EMC32 test software	Rohde&Schwarz	EMC32	NA	NA	NA
LISN network	Rohde&Schwarz	ENV216	101922	Feb. 26,19	Feb. 25,20

NOTE:

1. The test was performed in CE shielded room.
2. The calibration interval of the above test instruments is 12 months. And the calibrations are traceable to CEPREI/CHINA, GRGT/CHINA and NIM/CHINA.

3.2.3 TEST PROCEDURES

- a. The EUT was placed 0.4 meters from the conducting wall of the shielded room with EUT being connected to the power mains through a line impedance stabilization network (LISN). Other support units were connected to the power mains through another LISN. The two LISNs provide 50 ohm/ 50uH of coupling impedance for the measuring instrument.
- b. Both lines of the power mains connected to the EUT were checked for maximum conducted interference.
- c. The frequency range from 150kHz to 30MHz was searched. Emission levels under (Limit - 20dB) was not recorded.

NOTE: All modes of operation were investigated and the worst-case emissions are reported.



3.2.4 DEVIATION FROM TEST STANDARD

No deviation.

3.2.5 TEST SETUP

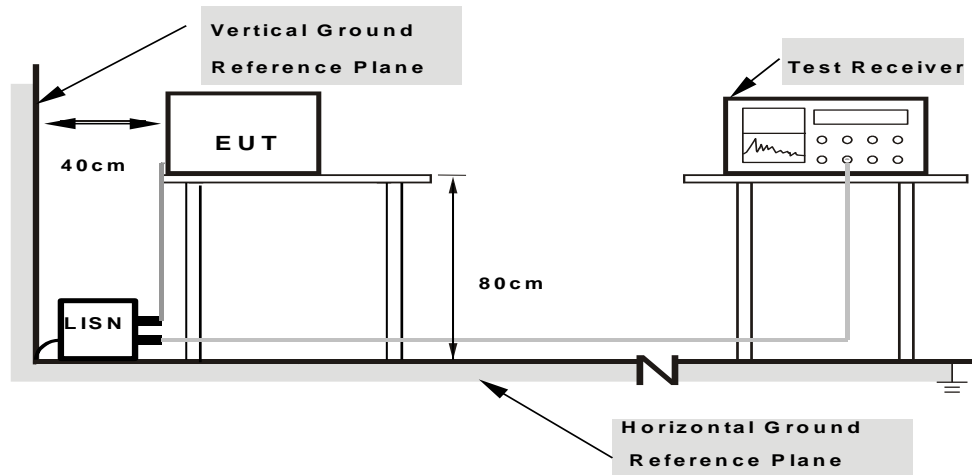

Note: 1.Support units were connected to second LISN.

**2.Both of LISNs (AMN) are 80 cm from EUT and at least 80
from other units and other metal planes**

For the actual test configuration, please refer to the attached file (Test Setup Photo).

3.2.6 EUT OPERATING CONDITIONS

Same as 3.1.6.



3.2.7 TEST RESULTS

CONDUCTED WORST-CASE DATA :

Frequency Range	150KHz ~ 30MHz	Detector Function & Resolution Bandwidth	Quasi-Peak (QP) / Average (AV), 9 kHz
Input Power	120Vac, 60Hz	Environmental Conditions	25deg. C, 52RH
Tested By	Jacky Liu		

Frequency (MHz)	QuasiPeak (dBuV)	CAverage (dBuV)	Limit (dBuV)	Margin (dB)	Line	Filter	Corr. (dB)
0.150000	---	16.55	56.00	-39.45	L1	ON	9.9
0.150000	31.63	---	66.00	-34.37	L1	ON	9.9
0.260000	---	15.26	51.43	-36.17	L1	ON	10.0
0.260000	26.74	---	61.43	-34.69	L1	ON	10.0
0.540000	---	27.33	46.00	-18.67	L1	ON	10.0
0.540000	34.27	---	56.00	-21.73	L1	ON	10.0
2.140000	---	12.94	46.00	-33.06	L1	ON	10.1
2.140000	21.10	---	56.00	-34.90	L1	ON	10.1
2.884000	---	15.33	46.00	-30.67	L1	ON	10.1
2.884000	22.03	---	56.00	-33.97	L1	ON	10.1
3.932000	---	15.56	46.00	-30.44	L1	ON	10.2
3.932000	21.50	---	56.00	-34.50	L1	ON	10.2

- REMARKS:**
1. Q.P. and AV. are abbreviations of quasi-peak and average individually.
 2. "-": The Quasi-peak reading value also meets average limit and measurement with the average detector is unnecessary.
 3. The emission levels of other frequencies were very low against the limit.
 4. Margin value = Emission level - Limit value
 5. Correction factor = Insertion loss + Cable loss
 6. Emission Level = Correction Factor + Reading Value.

Full Spectrum

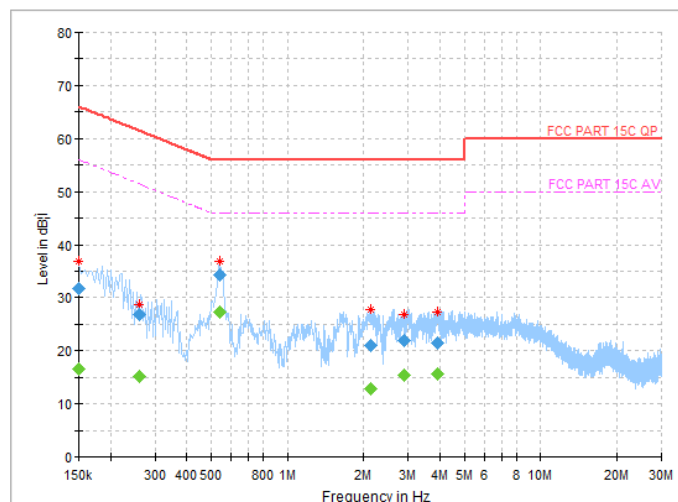



Frequency Range	150KHz ~ 30MHz	Detector Function & Resolution Bandwidth	Quasi-Peak (QP) / Average (AV), 9 kHz
Input Power	120Vac, 60Hz	Environmental Conditions	25deg. C, 52RH
Tested By	Jacky Liu		

Frequency (MHz)	QuasiPeak (dBuV)	CAverage (dBuV)	Limit (dBuV)	Margin (dB)	Line	Filter	Corr. (dB)
0.260000	---	14.89	51.43	-36.54	N	ON	9.9
0.260000	24.85	---	61.43	-36.58	N	ON	9.9
0.540000	---	16.12	46.00	-29.88	N	ON	9.9
0.540000	29.63	---	56.00	-26.37	N	ON	9.9
0.888000	---	12.48	46.00	-33.52	N	ON	10.0
0.888000	23.20	---	56.00	-32.80	N	ON	10.0
1.406000	---	12.51	46.00	-33.49	N	ON	10.0
1.406000	19.19	---	56.00	-36.81	N	ON	10.0
2.350000	---	8.20	46.00	-37.80	N	ON	10.0
2.350000	17.52	---	56.00	-38.48	N	ON	10.0
3.944000	---	13.07	46.00	-32.93	N	ON	10.1
3.944000	21.32	---	56.00	-34.68	N	ON	10.1

- REMARKS:**
1. Q.P. and AV. are abbreviations of quasi-peak and average individually.
 2. "-": The Quasi-peak reading value also meets average limit and measurement with the average detector is unnecessary.
 3. The emission levels of other frequencies were very low against the limit.
 4. Margin value = Emission level - Limit value
 5. Correction factor = Insertion loss + Cable loss
 6. Emission Level = Correction Factor + Reading Value.

Full Spectrum

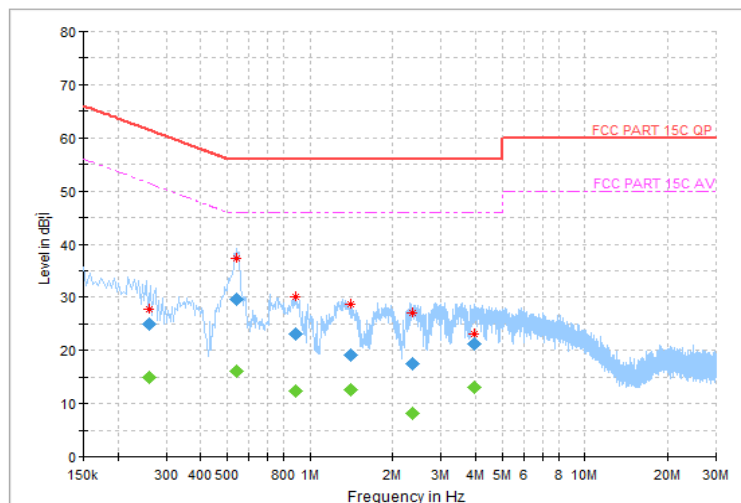



3.3 MAXIMUM CONDUCTED OUTPUT POWER MEASUREMENT

3.3.1 LIMITS OF MAXIMUM CONDUCTED OUTPUT POWER MEASUREMENT

Operation Band	EUT Category		LIMIT
U-NII-1		Outdoor Access Point	1 Watt (30 dBm) (Max. e.i.r.p ≤ 125mW(21 dBm) at any elevation angle above 30 degrees as measured from the horizon)
		Fixed point-to-point Access Point	1 Watt (30 dBm)
		Indoor Access Point	1 Watt (30 dBm)
	√	Client devices	250mW (24 dBm)
U-NII-2A	√		250mW (24 dBm) or 11 dBm+10 log B*
U-NII-2C	√		250mW (24 dBm) or 11 dBm+10 log B*
U-NII-3	√		1 Watt (30 dBm)

NOTE: Where B is the 26dB emission bandwidth in MHz.



3.3.2 TEST SETUP

FOR POWER OUTPUT MEASUREMENT

802.11a, 802.11n (20MHz), 802.11n (40MHz) TEST CONFIGURATION

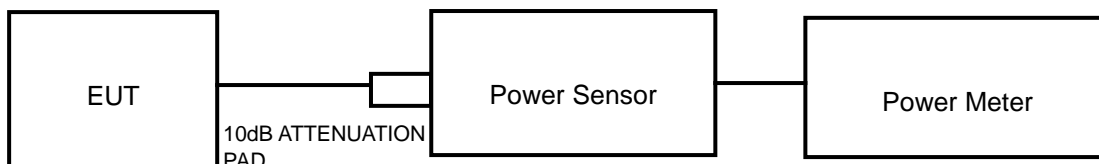

11ac TEST CONFIGURATION

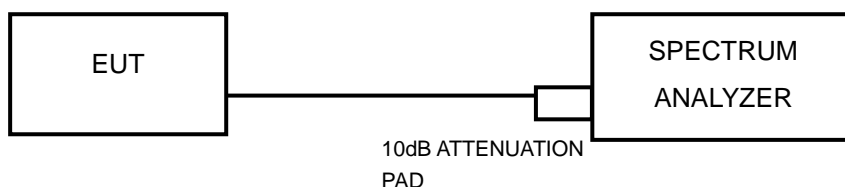

FOR 26dB BANDWIDTH

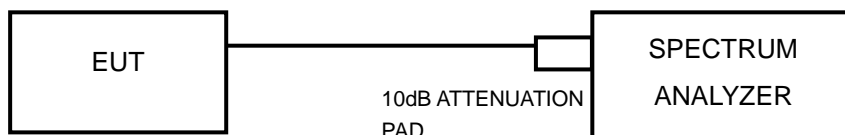

3.3.3 TEST INSTRUMENTS

Equipment	Manufacturer	Model No.	Serial No.	Last Cal.	Next Cal.
Power Meter	ANRITSU	ML2495A	1506002	Feb. 26,19	Feb. 25,20
EXA Signal Analyzer	KEYSIGHT	N9010A-526	MY54510322	Feb. 26,19	Feb. 25,20
EXA Signal Analyzer	KEYSIGHT	N9010A-544	MY54510355	Feb. 26,19	Feb. 25,20
Power Sensor	ANRITSU	MA2411B	1339352	Feb. 26,19	Feb. 25,20

NOTE:

1. The calibration interval of the above test instruments is 12 months and the calibrations are traceable to CEPREI/CHINA, GRGT/CHINA and NIM/CHINA.
2. The test was performed in RF Oven room.



3.3.4 TEST PROCEDURE

FOR POWER MEASUREMENT

For 802.11a, 802.11n (20MHz), 802.11n (40MHz)

Method PM is used to perform output power measurement, trigger and gating function of wide band power meter is enabled to measure max output power of TX on burst. Duty factor is not added to measured value.

For 802.11ac (80MHz)

1. Measure the duty cycle, x , of the transmitter output signal as described in II.B.
2. Set span to encompass the EBW (or, alternatively, the entire 99% occupied bandwidth) of the signal.
3. Set RBW = 1 MHz.
4. Set VBW \geq 3 MHz.
5. Number of points in sweep $\geq 2 \times \text{span} / \text{RBW}$. (This ensures that bin-to-bin spacing is $\leq \text{RBW}/2$, so that narrowband signals are not lost between frequency bins.)
6. Sweep time = auto.
7. Detector = power averaging (rms), if available. Otherwise, use sample detector mode.
8. Do not use sweep triggering. Allow the sweep to “free run.”
9. Trace average at least 100 traces in power averaging (rms) mode; however, the number of traces to be averaged shall be increased above 100 as needed to ensure that the average accurately represents the true average over the on and off periods of the transmitter.
10. Add $10 \log (1/x)$, where x is the duty cycle, to the measured power to compute the average power during the actual transmission times (because the measurement represents an average over both the on and off times of the transmission). For example, add $10 \log (1/0.25) = 6 \text{ dB}$ if the duty cycle is 25%.



FOR 99 PERCENT OCCUPIED BANDWIDTH

The following procedure shall be used for measuring (99 %) power bandwidth:

1. Set center frequency to the nominal EUT channel center frequency.
2. Set span = 1.5 times to 5.0 times the OBW.
3. Set RBW = 1 % to 5 % of the OBW
4. Set VBW $\geq 3 \cdot$ RBW
5. Video averaging is not permitted. Where practical, a sample detection and single sweep mode shall be used. Otherwise, peak detection and max hold mode (until the trace stabilizes) shall be used.
6. Use the 99 % power bandwidth function of the instrument (if available).
7. If the instrument does not have a 99 % power bandwidth function, the trace data points are recovered and directly summed in power units. The recovered amplitude data points, beginning at the lowest frequency, are placed in a running sum until 0.5 % of the total is reached; that frequency is recorded as the lower frequency. The process is repeated until 99.5 % of the total is reached; that frequency is recorded as the upper frequency. The 99% occupied bandwidth is the difference between these two frequencies.

FOR 26dB BANDWIDTH

- 1) Set RBW = approximately 1% of the emission bandwidth.
- 2) Set the VBW > RBW.
- 3) Detector = Peak.
- 4) Trace mode = max hold.
- 5) Measure the maximum width of the emission that is 26 dB down from the peak of the emission. Compare this with the RBW setting of the analyzer. Readjust RBW and repeat measurement as needed until the RBW/EBW ratio is approximately 1%.

FOR 6dB BANDWIDTH

1. Set RBW = 100 kHz.
2. Set the video bandwidth (VBW) ≥ 3 RBW.
3. Detector = Peak.
4. Trace mode = max hold.
5. Sweep = auto couple.
6. Allow the trace to stabilize.
7. Measure the maximum width of the emission that is constrained by the frequencies associated with the two outermost amplitude points (upper and lower frequencies) that are attenuated by 6 dB relative to the maximum level measured in the fundamental emission.



3.3.5 DEVIATION FROM TEST STANDARD

No deviation.

3.3.6 EUT OPERATING CONDITIONS

The software provided by client to enable the EUT under transmission condition continuously at specific channel frequencies individually.



3.3.7 TEST RESULTS

OUTPUT POWER:

802.11a

CHANNEL	CHANNEL FREQUENCY (MHz)	AVERAGE POWER (dBm)	Duty Factor	FINAL AVERAGE POWER (dBm)	FINAL AVERAGE POWER (mW)	POWER LIMIT (dBm)	PASS/FAIL
36	5180	16.64	0.12	16.76	47.46	24	PASS
40	5200	16.75	0.12	16.87	48.67	24	PASS
48	5240	17.01	0.12	17.13	51.68	24	PASS
52	5260	17.05	0.12	17.17	52.16	24	PASS
60	5300	17.25	0.12	17.37	54.61	24	PASS
64	5320	17.21	0.12	17.33	54.11	24	PASS
100	5500	18.07	0.12	18.19	65.96	24	PASS
116	5580	17.93	0.12	18.05	63.87	24	PASS
140	5700	17.25	0.12	17.37	54.61	24	PASS
149	5745	17.21	0.12	17.33	54.11	30	PASS
157	5785	17.34	0.12	17.46	55.76	30	PASS
161	5805	17.42	0.12	17.54	56.79	30	PASS



802.11n (20MHz)

CHANNEL	CHANNEL FREQUENCY (MHz)	AVERAGE POWER (dBm)	Duty Factor	FINAL AVERAGE POWER (dBm)	FINAL AVERAGE POWER (mW)	POWER LIMIT (dBm)	PASS/FAIL
36	5180	15.61	/	/	36.39	24	PASS
40	5200	15.63	/	/	36.56	24	PASS
48	5240	15.87	/	/	38.64	24	PASS
52	5260	15.98	/	/	39.63	24	PASS
60	5300	16.02	/	/	39.99	24	PASS
64	5320	16.05	/	/	40.27	24	PASS
100	5500	17.01	/	/	50.23	24	PASS
116	5580	16.96	/	/	49.66	24	PASS
140	5700	16.03	/	/	40.09	24	PASS
149	5745	16.28	/	/	42.46	30	PASS
157	5785	16.23	/	/	41.98	30	PASS
161	5805	16.32	/	/	42.85	30	PASS



802.11n (40MHz)

CHANNEL	CHANNEL FREQUENCY (MHz)	AVERAGE POWER (dBm)	Duty Factor	FINAL AVERAGE POWER (dBm)	FINAL AVERAGE POWER (mW)	POWER LIMIT (dBm)	PASS/FAIL
38	5190	14.96	0.21	15.17	32.89	24	PASS
46	5230	15.09	0.21	15.30	33.89	24	PASS
54	5270	15.27	0.21	15.48	35.33	24	PASS
62	5310	15.41	0.21	15.62	36.48	24	PASS
102	5510	16.25	0.21	16.46	44.27	24	PASS
110	5550	16.28	0.21	16.49	44.58	24	PASS
134	5670	15.56	0.21	15.77	37.77	24	PASS
151	5755	16.13	0.21	16.34	43.06	30	PASS
159	5795	16.38	0.21	16.59	45.61	30	PASS

802.11ac (80MHz)

CHANNEL	CHANNEL FREQUENCY (MHz)	AVERAGE POWER (dBm)	Duty Factor	FINAL AVERAGE POWER (dBm)	FINAL AVERAGE POWER (mW)	POWER LIMIT (dBm)	PASS/FAIL
42	5210	13.71	0.41	14.12	25.85	24	PASS
58	5290	13.95	0.41	14.36	27.31	24	PASS
106	5530	14.84	0.41	15.25	33.53	24	PASS
155	5775	13.86	0.41	14.27	26.75	30	PASS



99% OCCUPIED BANDWIDTH & 26dB BANDWIDTH/6dB BANDWIDTH DATA FROM:

802.11a

CHANNEL	CHANNEL FREQUENCY (MHz)	99% OCCUPIED BANDWIDTH (MHz)	26dB BANDWIDTH (MHz)	PASS/FAIL
36	5180	16.56	22.16	PASS
40	5200	16.62	22.07	PASS
48	5240	16.62	22.19	PASS
52	5260	16.62	22.17	PASS
60	5300	16.62	22.14	PASS
64	5320	16.62	22.13	PASS
100	5500	16.56	21.39	PASS
116	5580	16.56	21.35	PASS
140	5700	16.56	22.03	PASS
CHANNEL	CHANNEL FREQUENCY (MHz)	99% OCCUPIED BANDWIDTH (MHz)	6dB BANDWIDTH (MHz)	PASS/FAIL
149	5745	16.50	15.34	PASS
157	5785	16.56	15.32	PASS
161	5805	17.70	17.15	PASS



802.11n (20MHz)

CHANNEL	CHANNEL FREQUENCY (MHz)	99% OCCUPIED BANDWIDTH (MHz)	26dB BANDWIDTH (MHz)	PASS/FAIL
36	5180	17.76	23.40	PASS
40	5200	17.82	23.12	PASS
48	5240	17.76	23.33	PASS
52	5260	17.76	23.00	PASS
60	5300	17.82	23.34	PASS
64	5320	17.76	23.16	PASS
100	5500	17.76	23.08	PASS
116	5580	17.82	23.05	PASS
140	5700	17.76	23.06	PASS
CHANNEL	CHANNEL FREQUENCY (MHz)	99% OCCUPIED BANDWIDTH (MHz)	6dB BANDWIDTH (MHz)	PASS/FAIL
149	5745	17.70	15.93	PASS
157	5785	17.76	15.98	PASS
161	5805	17.76	15.94	PASS



802.11n (40MHz)

CHANNEL	CHANNEL FREQUENCY (MHz)	99% OCCUPIED BANDWIDTH (MHz)	26dB BANDWIDTH (MHz)	PASS/FAIL
38	5190	36.42	41.68	PASS
46	5230	36.48	41.84	PASS
54	5270	36.36	41.78	PASS
62	5310	36.48	41.64	PASS
102	5510	36.48	41.76	PASS
110	5550	36.48	41.72	PASS
134	5670	36.54	41.82	PASS
CHANNEL	CHANNEL FREQUENCY (MHz)	99% OCCUPIED BANDWIDTH (MHz)	6dB BANDWIDTH (MHz)	PASS/FAIL
151	5755	36.36	35.74	PASS
159	5795	36.42	35.08	PASS

802.11ac (80MHz)

CHANNEL	CHANNEL FREQUENCY (MHz)	99% OCCUPIED BANDWIDTH (MHz)	26dB BANDWIDTH (MHz)	PASS/FAIL
42	5210	75.72	84.15	PASS
58	5290	75.84	83.86	PASS
106	5530	75.72	84.17	PASS
CHANNEL	CHANNEL FREQUENCY (MHz)	99% OCCUPIED BANDWIDTH (MHz)	6dB BANDWIDTH (MHz)	PASS/FAIL
155	5775	75.84	74.72	PASS



BUREAU VERITAS

Test Report No.: RF190712W002

For U-NII-1:

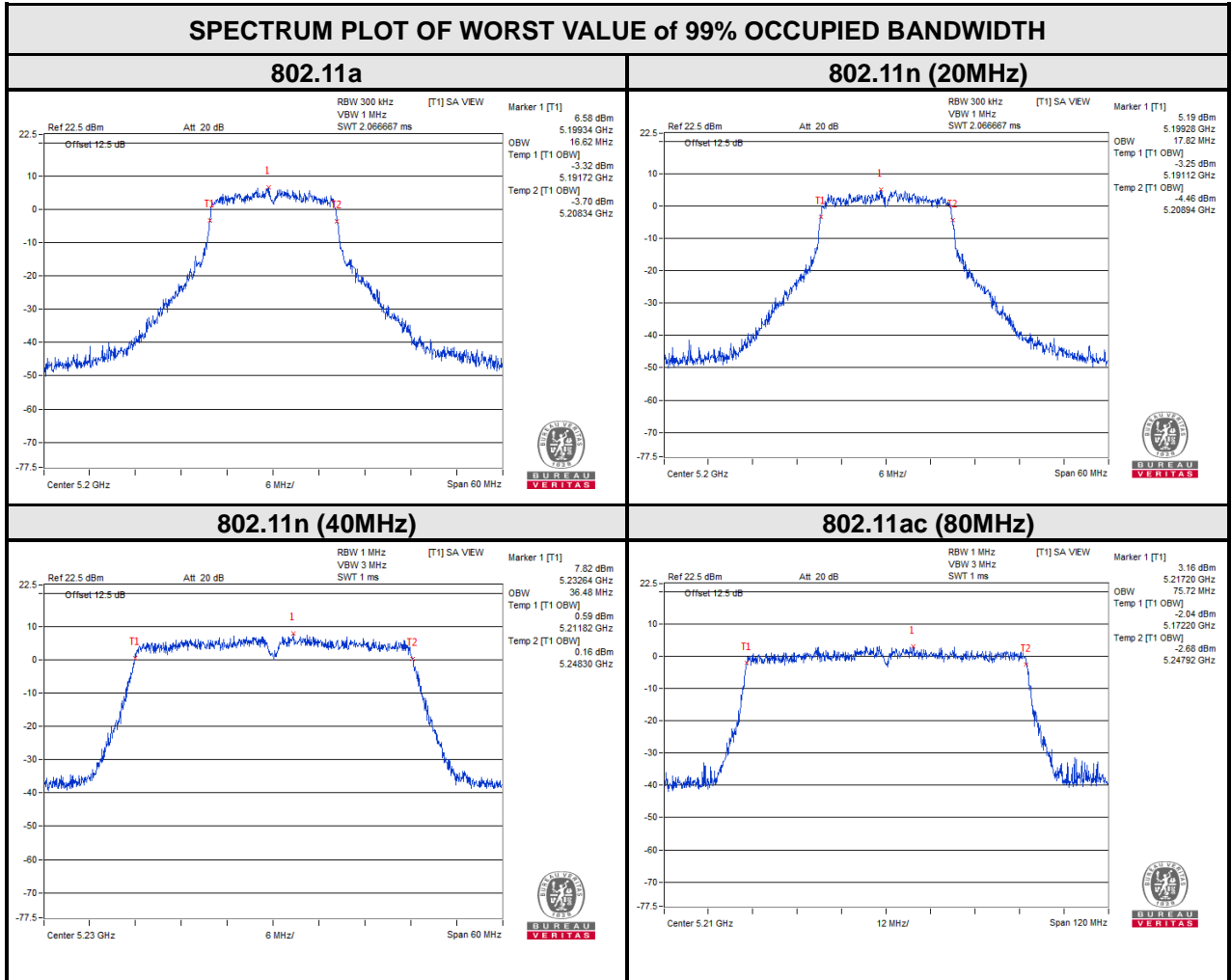



BUREAU VERITAS

Test Report No.: RF190712W002

SPECTRUM PLOT OF WORST VALUE of 26dB Bandwidth

802.11a

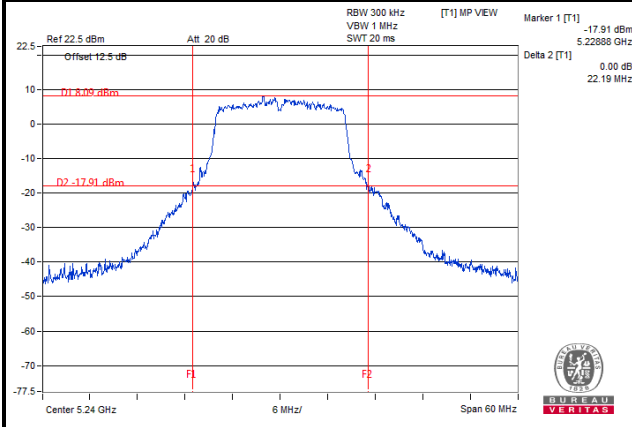

802.11n (20MHz)

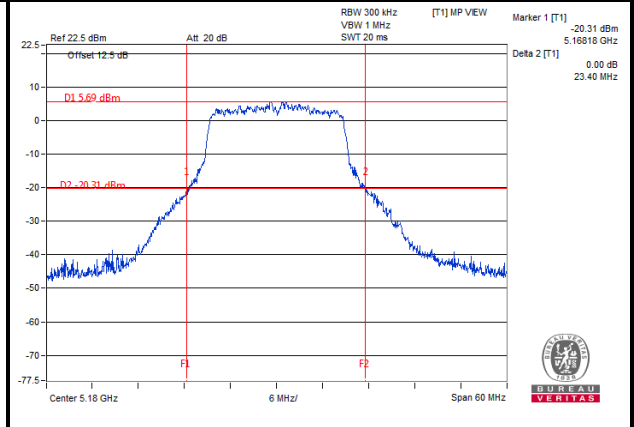

802.11n (40MHz)

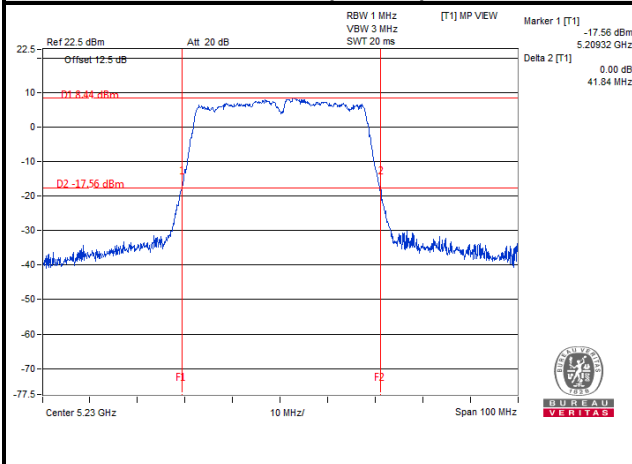

802.11ac (80MHz)

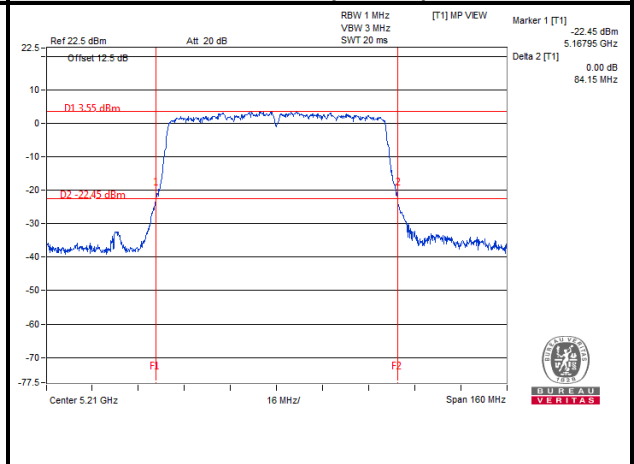



BUREAU VERITAS

Test Report No.: RF190712W002

For U-NII-2A:

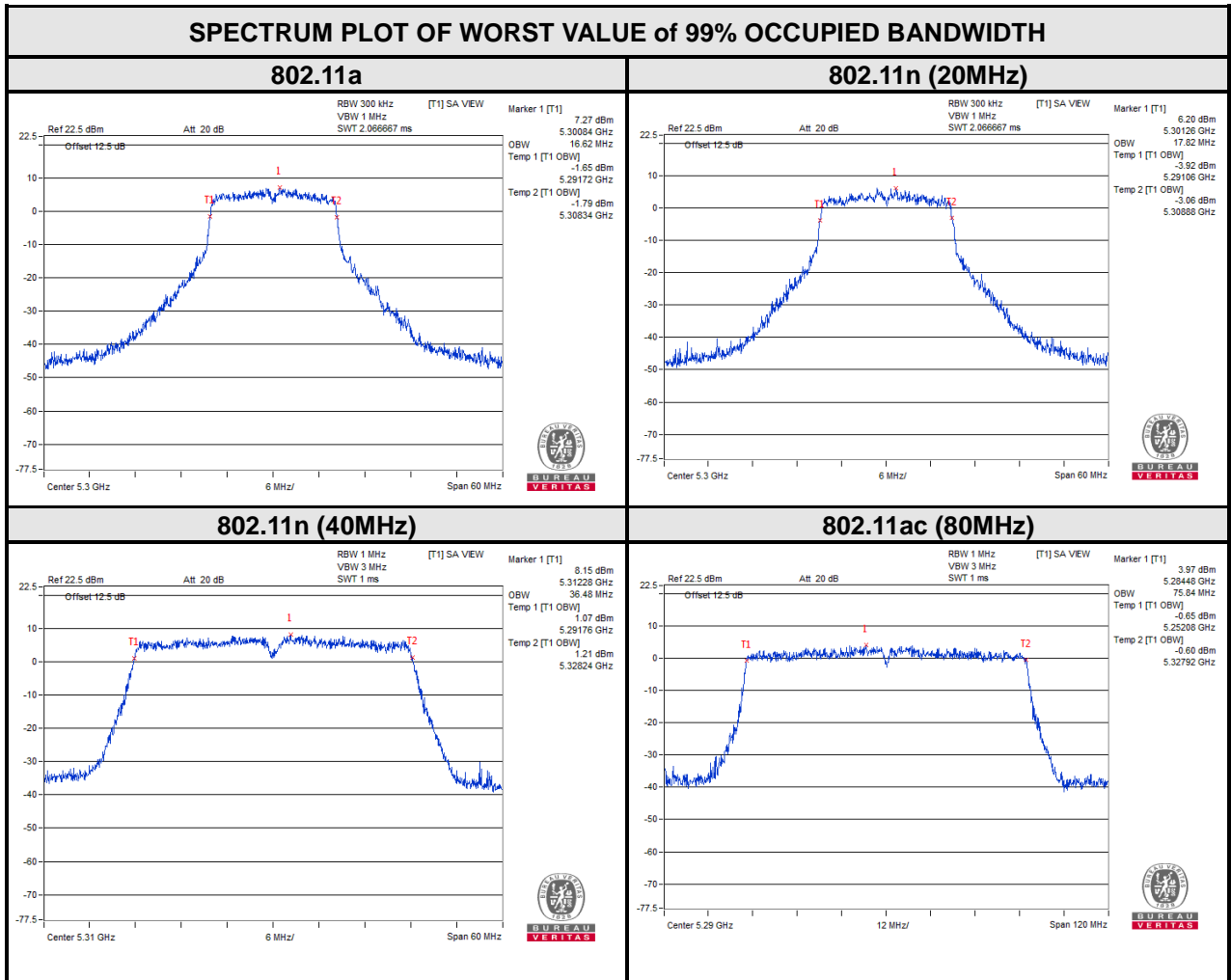



BUREAU VERITAS

Test Report No.: RF190712W002

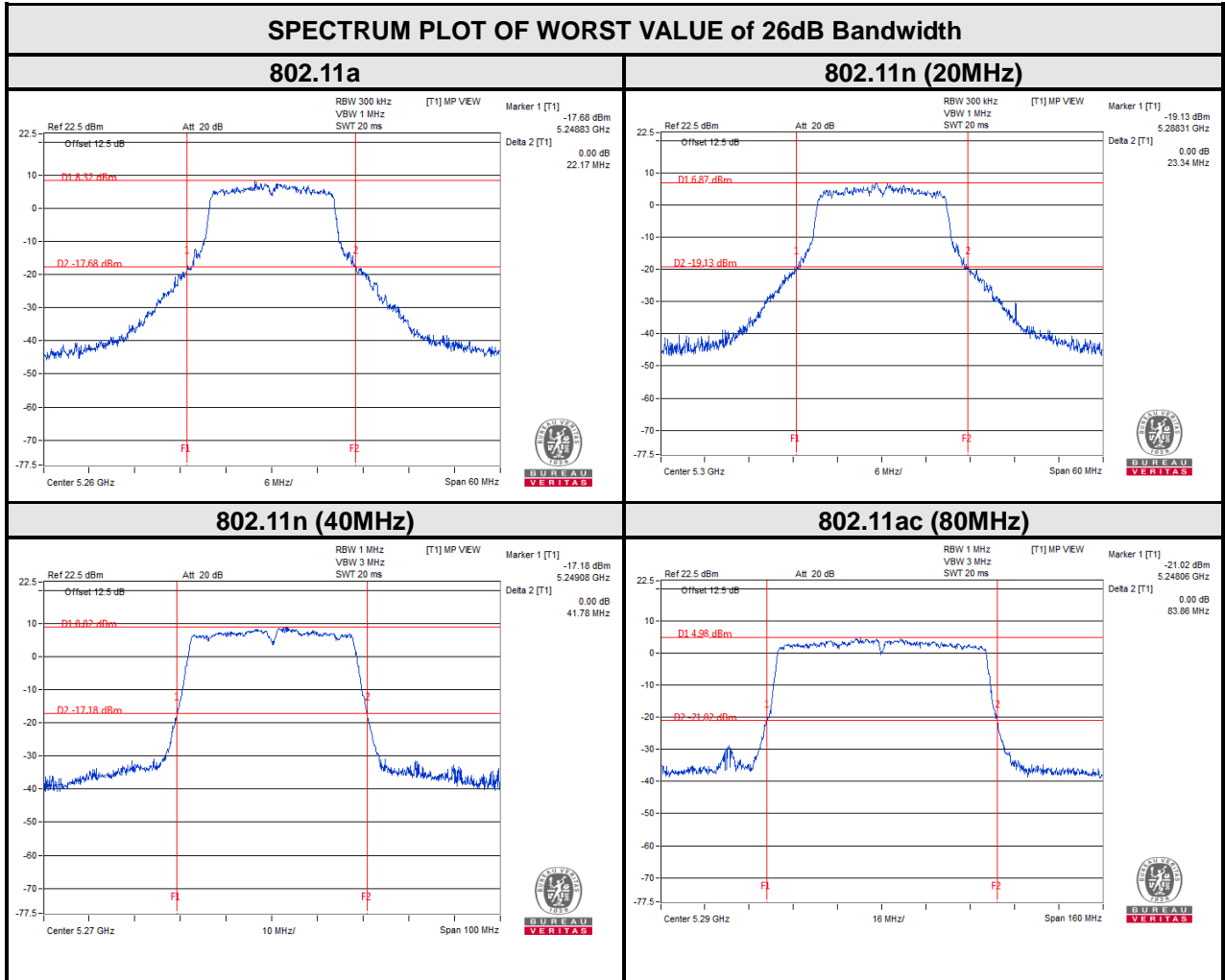



For U-NII-2C:

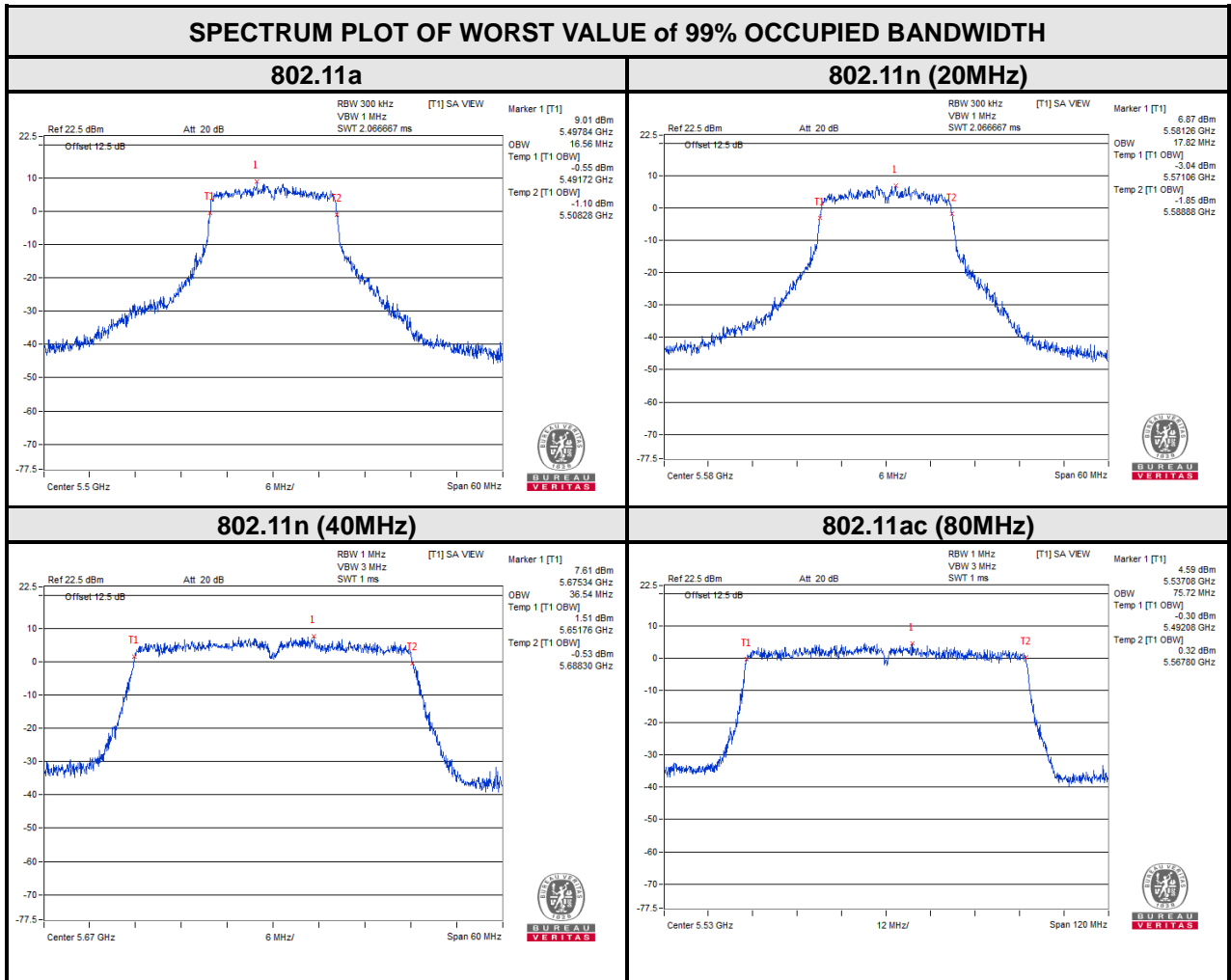



BUREAU VERITAS

Test Report No.: RF190712W002

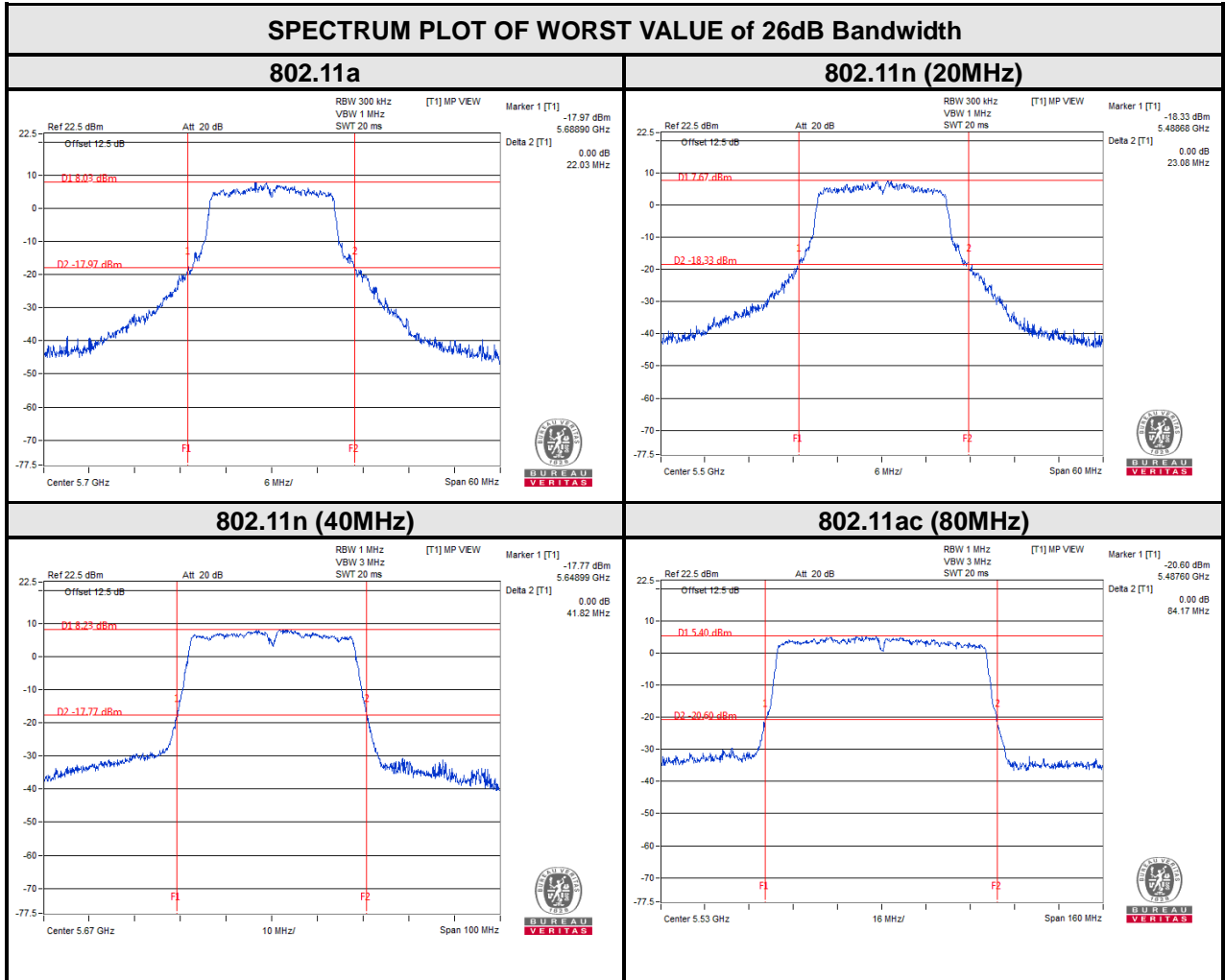



BUREAU VERITAS

Test Report No.: RF190712W002

For U-NII-3:

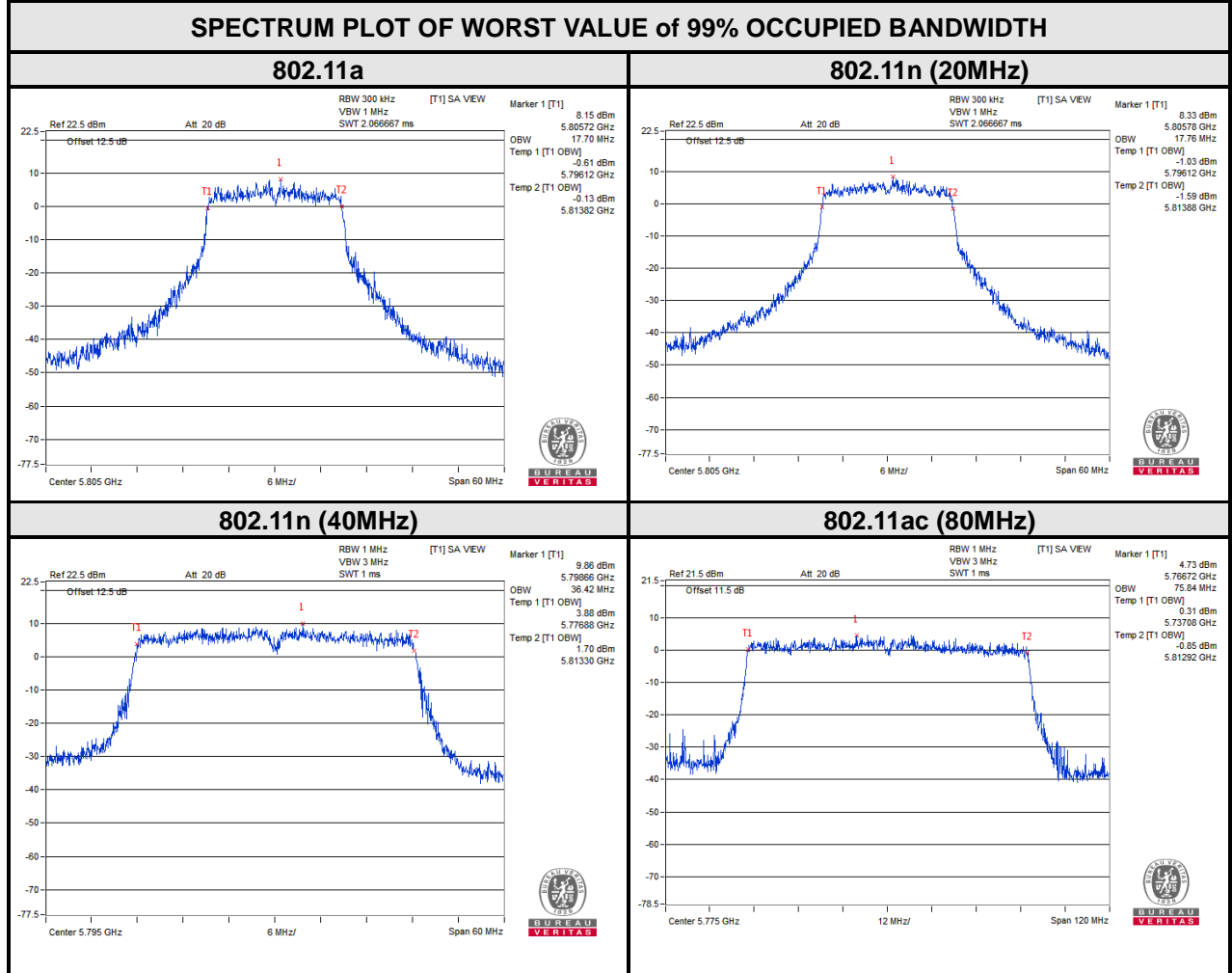

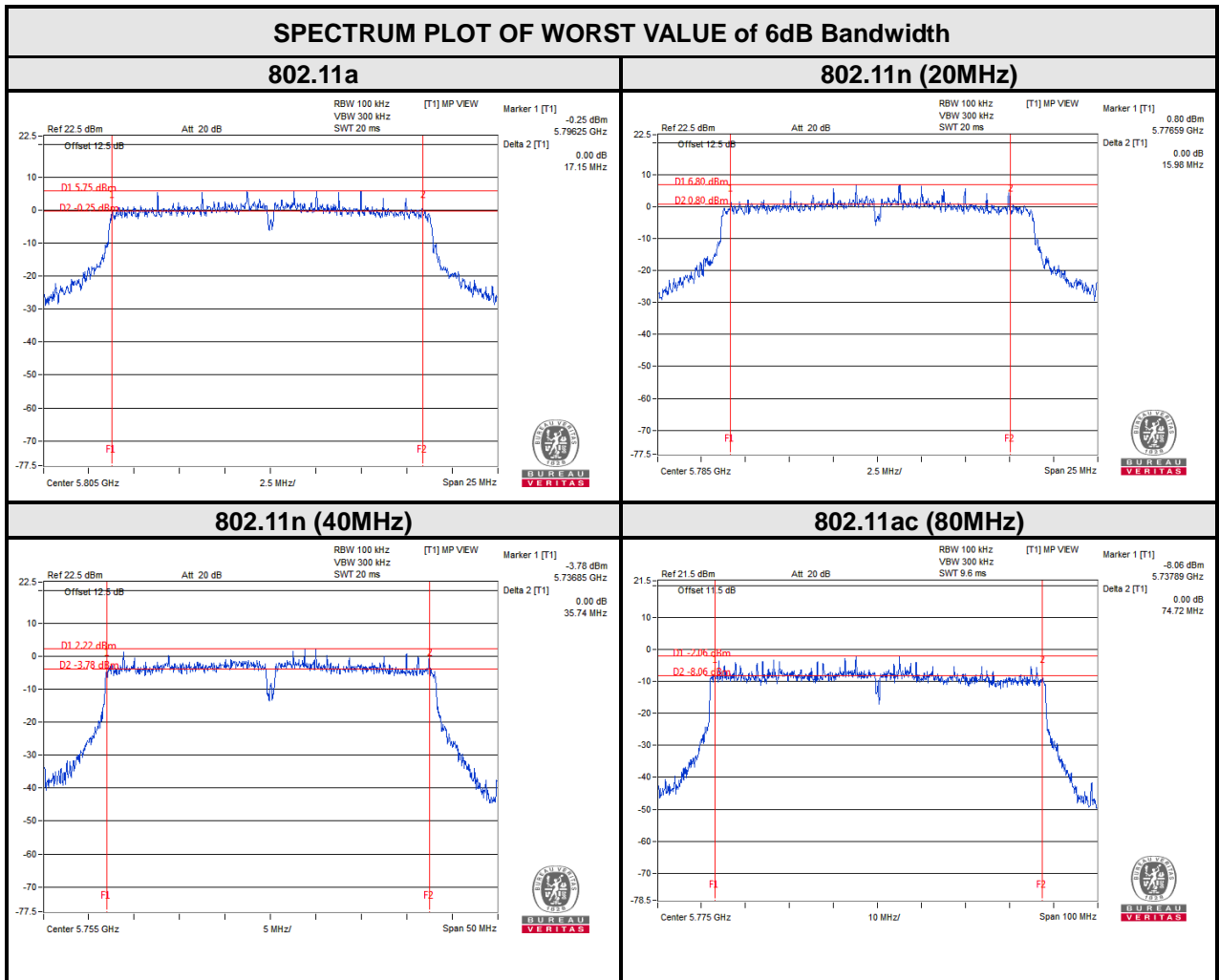



3.4 MAXIMUM POWER SPECTRAL DENSITY MEASUREMENT

3.4.1 LIMITS OF MAXIMUM POWER SPECTRAL DENSITY MEASUREMENT

Operation Band	EUT Category		LIMIT
U-NII-1		Outdoor Access Point	17dBm/ MHz
		Fixed point-to-point Access Point	
		Indoor Access Point	
	√	Client devices	11dBm/ MHz
U-NII-2A		√	11dBm/ MHz
U-NII-2C		√	11dBm/ MHz
U-NII-3		√	30dBm/ 500kHz

3.4.2 TEST SETUP

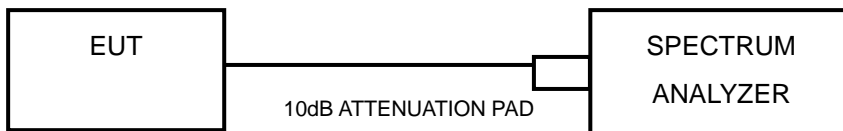

3.4.3 TEST INSTRUMENTS

Refer to section 3.3.3 to get information of above instrument.



3.4.4 TEST PROCEDURES

Using method SA-2

- 1) Set span to encompass the entire emission bandwidth (EBW) of the signal.
- 2) Set RBW = 1 MHz, Set VBW \geq 3 MHz, Detector = RMS
- 3) Set Channel power measure = 1MHz
- 4) Sweep time = auto, trigger set to "free run".
- 5) Trace average at least 100 traces in power averaging mode.
- 6) Add $10 \log(1/x)$, where x is the duty cycle, to the measured power in order to compute the average power during the actual transmission times (because the measurement represents an average over both the on and off times of the transmission).
- 7) Record the max value

3.4.5 DEVIATION FROM TEST STANDARD

No deviation.

3.4.6 EUT OPERATING CONDITIONS

Same as 3.1.6.



3.4.7 TEST RESULTS

For U-NII-1 & U-NII-2A& U-NII-2C:

802.11a

CHANNEL	FREQUENCY (MHz)	PSD w/o Duty Factor (dBm/MHz)	Duty Factor	PSD with Duty Factor (dBm/MHz)	MAXIMUM LIMIT (dBm/MHz)	PASS/FAIL
36	5180	8.95	0.12	9.07	11	PASS
40	5200	9.00	0.12	9.12	11	PASS
48	5240	9.55	0.12	9.67	11	PASS
52	5260	9.69	0.12	9.81	11	PASS
60	5300	10.32	0.12	10.44	11	PASS
64	5320	10.03	0.12	10.15	11	PASS
100	5500	10.67	0.12	10.79	11	PASS
116	5580	10.44	0.12	10.56	11	PASS
140	5700	9.61	0.12	9.73	11	PASS

802.11n (20MHz)

CHANNEL	FREQUENCY (MHz)	PSD w/o Duty Factor (dBm/MHz)	MAXIMUM LIMIT (dBm/MHz)	PASS/FAIL
36	5180	7.64	11	PASS
40	5200	7.82	11	PASS
48	5240	8.41	11	PASS
52	5260	8.62	11	PASS
60	5300	8.85	11	PASS
64	5320	8.51	11	PASS
100	5500	9.77	11	PASS
116	5580	9.66	11	PASS
140	5700	8.54	11	PASS



802.11n (40MHz)

CHANNEL	FREQUENCY (MHz)	PSD w/o Duty Factor (dBm/MHz)	Duty Factor	PSD with Duty Factor (dBm/MHz)	MAXIMUM LIMIT (dBm/MHz)	PASS/FAIL
38	5190	3.80	0.21	4.01	11	PASS
46	5230	3.97	0.21	4.18	11	PASS
54	5270	4.49	0.21	4.7	11	PASS
62	5310	4.80	0.21	5.01	11	PASS
102	5510	5.44	0.21	5.65	11	PASS
110	5550	5.15	0.21	5.36	11	PASS
134	5670	4.22	0.21	4.43	11	PASS

802.11ac (80MHz)

CHANNEL	FREQUENCY (MHz)	PSD w/o Duty Factor (dBm/MHz)	Duty Factor	PSD with Duty Factor (dBm/MHz)	MAXIMUM LIMIT (dBm/MHz)	PASS/FAIL
42	5210	0.16	0.41	0.57	11	PASS
58	5290	1.14	0.41	1.55	11	PASS
106	5530	1.90	0.41	2.31	11	PASS



For U-NII-3:

Note: dBm/500kHz= dBm/MHz+10*log(0.5/1)= dBm/MHz-3.01

802.11a

CHANNEL	FREQUENCY (MHz)	PSD w/o Duty Factor (dBm/MHz)	PSD w/o Duty Factor (dBm/500kHz)	Duty Factor	PSD with Duty Factor (dBm/500kHz)	LIMIT (dBm/500kHz)	PASS /FAIL
149	5745	7.46	4.45	0.12	4.57	30	PASS
157	5785	7.26	4.25	0.12	4.37	30	PASS
161	5805	5.94	2.93	0.12	3.05	30	PASS

802.11n (20MHz)

CHANNEL	FREQUENCY (MHz)	PSD w/o Duty Factor (dBm/MHz)	PSD w/o Duty Factor (dBm/500kHz)	LIMIT (dBm/500kHz)	PASS /FAIL
149	5745	5.16	2.15	30	PASS
157	5785	6.16	3.15	30	PASS
161	5805	6.27	3.26	30	PASS

802.11n (40MHz)

CHANNEL	FREQUENCY (MHz)	PSD w/o Duty Factor (dBm/MHz)	PSD w/o Duty Factor (dBm/500kHz)	Duty Factor	PSD with Duty Factor (dBm/500kHz)	LIMIT (dBm/500kHz)	PASS /FAIL
151	5755	2.29	-0.72	0.21	-0.51	30	PASS
159	5795	2.37	-0.64	0.21	-0.43	30	PASS

802.11ac (80MHz)

CHANNEL	FREQUENCY (MHz)	PSD w/o Duty Factor (dBm/MHz)	PSD w/o Duty Factor (dBm/500kHz)	Duty Factor	PSD with Duty Factor (dBm/500kHz)	LIMIT (dBm/500kHz)	PASS /FAIL
155	5775	-2.80	-5.81	0.41	-5.4	30	PASS



BUREAU VERITAS

Test Report No.: RF190712W002

For 5180~5240MHz

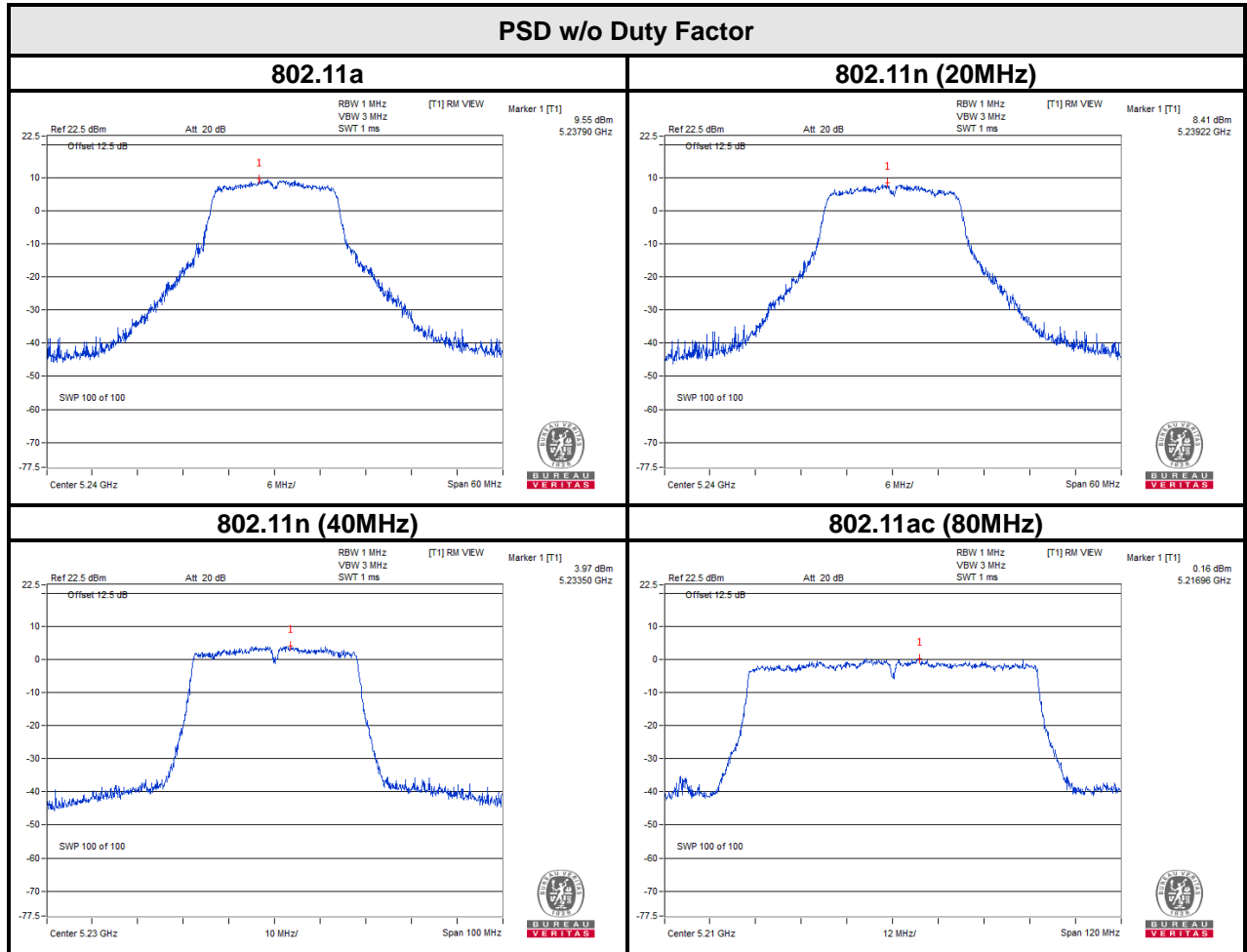



BUREAU VERITAS

Test Report No.: RF190712W002

For 5260~5320MHz

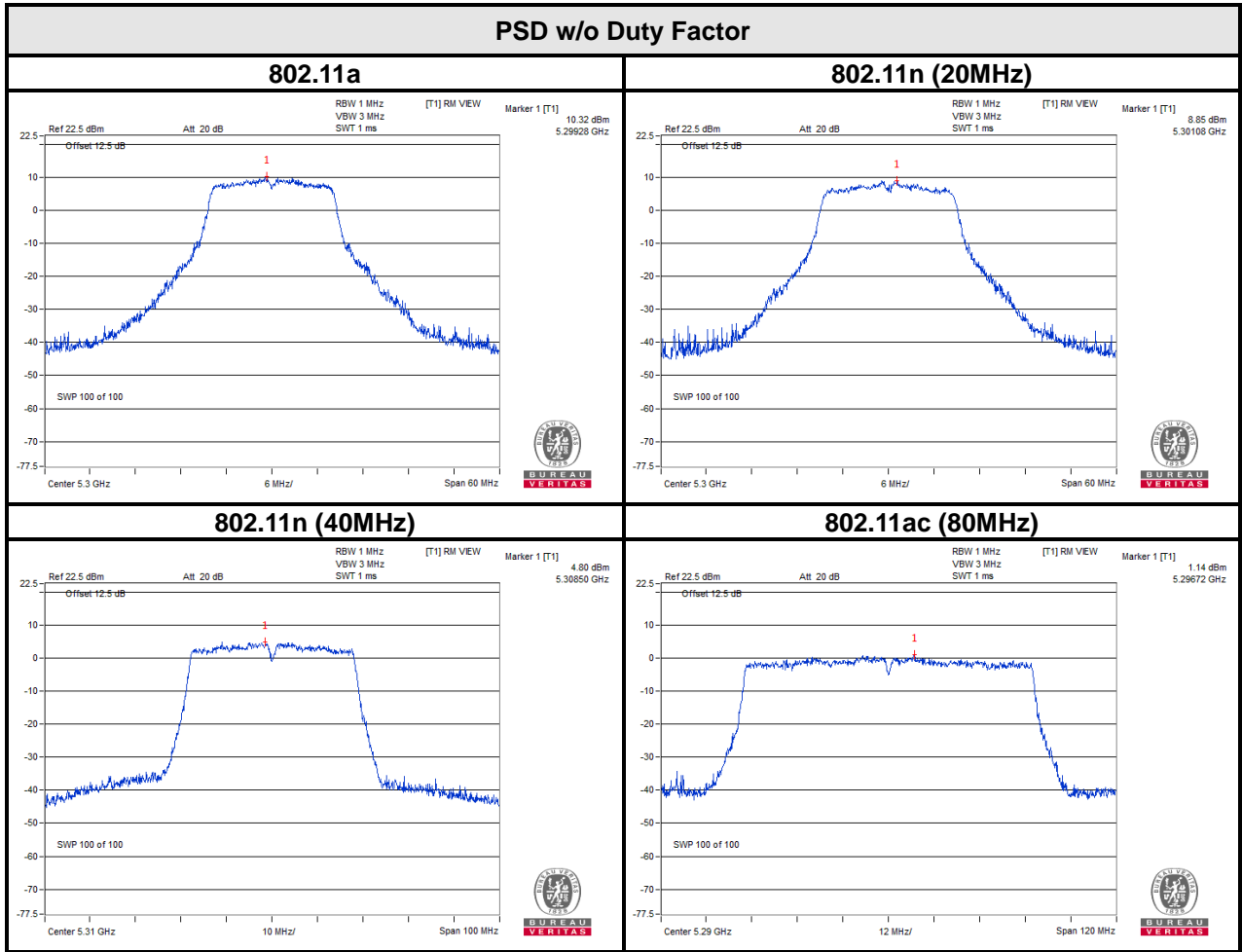



BUREAU VERITAS

Test Report No.: RF190712W002

For 5500~5700MHz

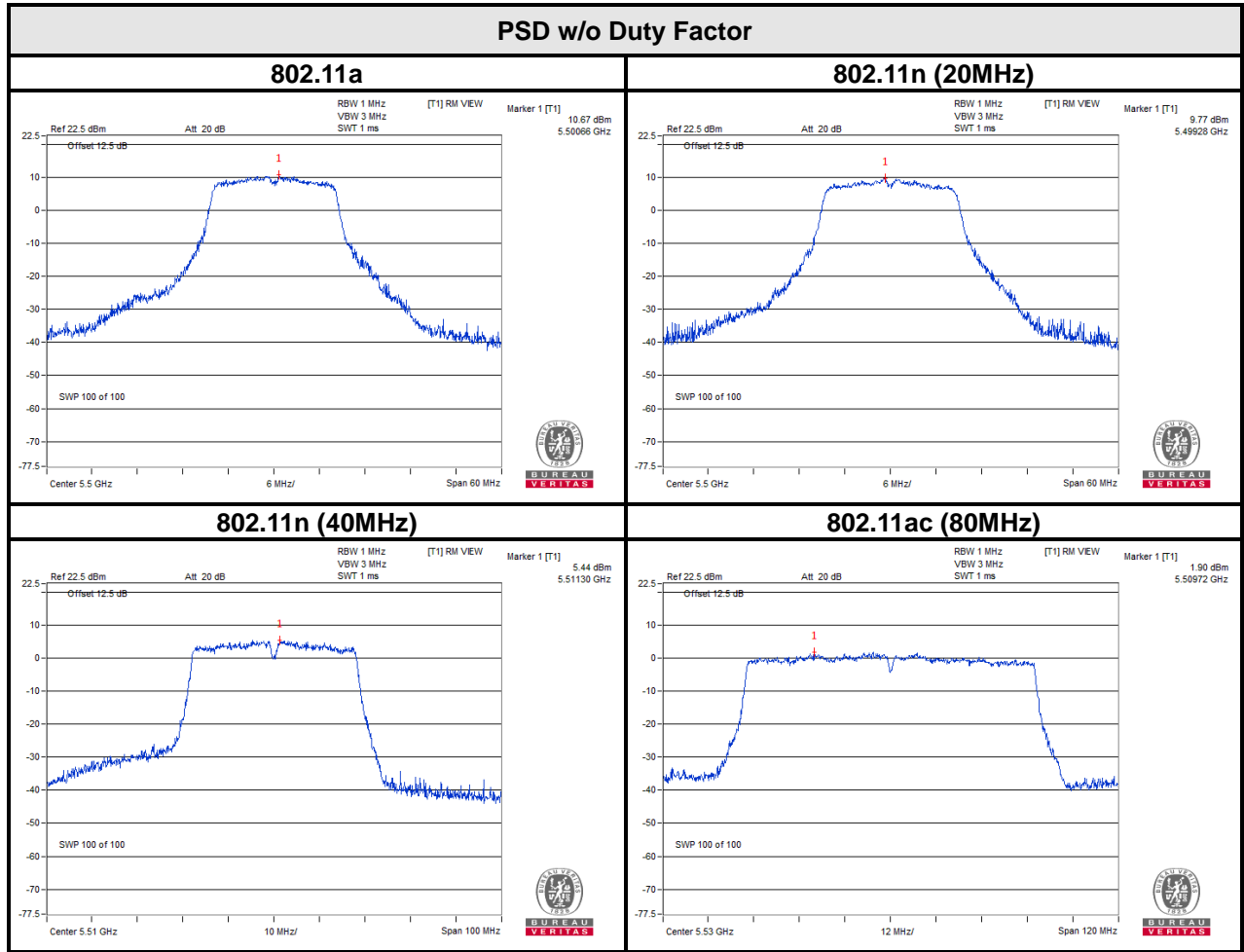



BUREAU
VERITAS

Test Report No.: RF190712W002

For 5745~5805MHz

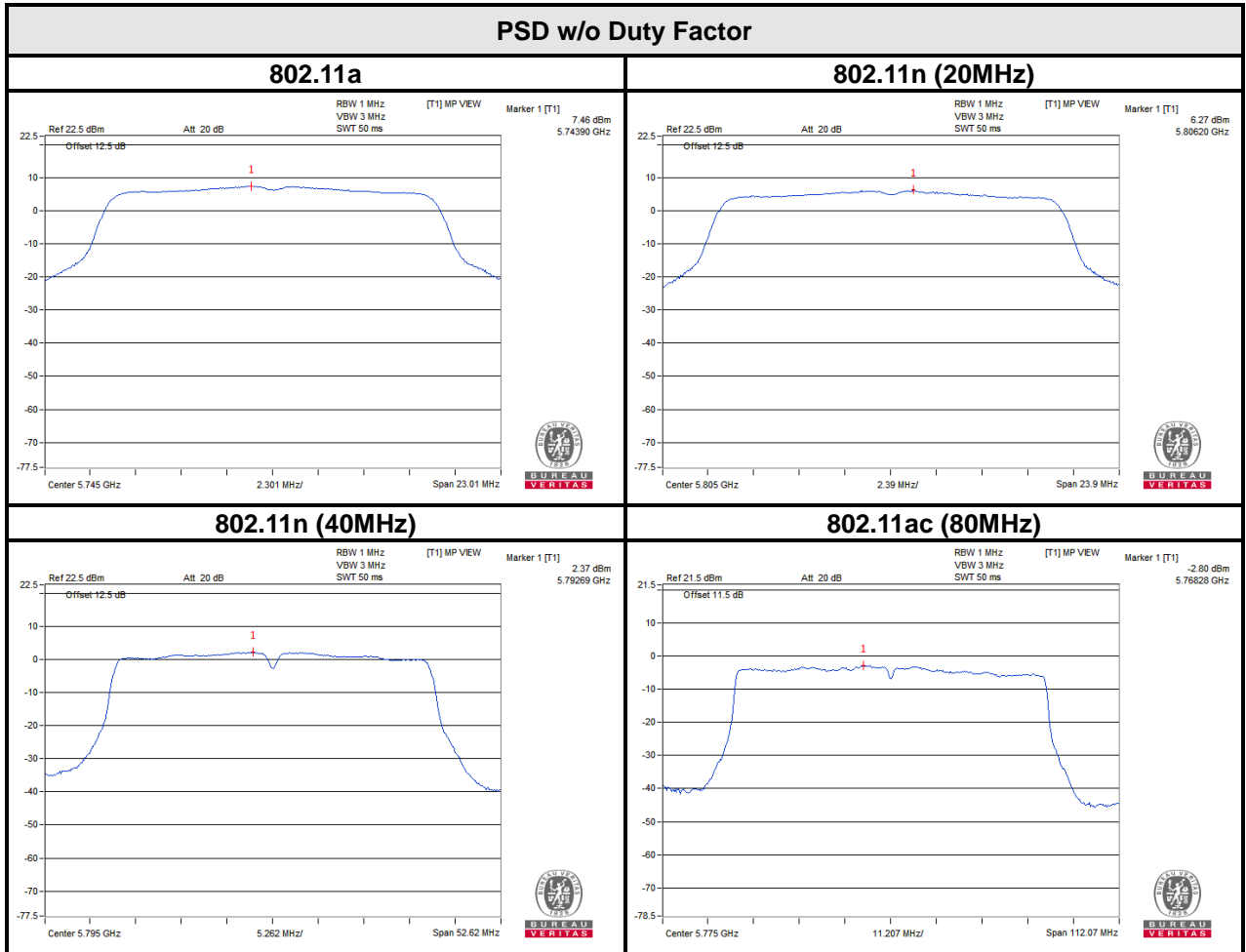



Test Report No.: RF190712W002

4 PHOTOGRAPHS OF THE TEST CONFIGURATION

Please refer to the attached file (Test Setup Photo).



Test Report No.: RF190712W002

5 APPENDIX A – MODIFICATIONS RECORDERS FOR ENGINEERING CHANGES TO THE EUT BY THE LAB

No modifications were made to the EUT by the lab during the test.

---END---