



RF TEST REPORT

Applicant Xiaomi Communications Co., Ltd.
FCC ID 2AFZZC3JG
Product Mobile Phone
Brand Redmi
Model M1908C3JG
Report No. R1907A0357-R5
Issue Date August 9, 2019

TA Technology (Shanghai) Co., Ltd. tested the above equipment in accordance with the requirements in **FCC CFR47 Part 15E (2018)**. The test results show that the equipment tested is capable of demonstrating compliance with the requirements as documented in this report.

Performed by: Peng Tao

Approved by: Kai Xu

TA Technology (Shanghai) Co., Ltd.

No.145, Jintang Rd, Tangzhen Industry Park, Pudong Shanghai, China

TEL: +86-021-50791141/2/3

FAX: +86-021-50791141/2/3-8000



TABLE OF CONTENT

1. Test Laboratory.....	4
1.1. Notes of the test report.....	4
1.2. Test facility.....	4
1.3. Testing Location.....	5
2. General Description of Equipment under Test.....	6
3. Applied Standards.....	8
4. Test Configuration.....	9
5. Test Case Results.....	12
5.1. Occupied Bandwidth.....	12
5.2. Average Power Output –Conducted.....	29
5.3. Frequency Stability.....	36
5.4. Power Spectral Density.....	40
5.5. Unwanted Emission.....	56
5.6. Conducted Emission.....	148
6. Main Test Instruments.....	151



Summary of measurement results

Number	Test Case	Clause in FCC rules	Verdict
1	Average conducted output power	15.407(a)	PASS
2	Occupied bandwidth	15.407(e)	PASS
3	Frequency stability	15.407(g)	PASS
4	Power spectral density	15.407(a)	PASS
5	Unwanted Emissions	15.407(b)	PASS
6	Conducted Emissions	15.207	PASS
Date of Testing: June 2, 2019 ~July 30, 2019			



1. Test Laboratory

1.1. Notes of the test report

This report shall not be reproduced in full or partial, without the written approval of **TA technology (shanghai) co., Ltd.** The results documented in this report apply only to the tested sample, under the conditions and modes of operation as described herein. Measurement Uncertainties were not taken into account and are published for informational purposes only. This report is written to support regulatory compliance of the applicable standards stated above.

1.2. Test facility

FCC (Designation number: CN1179, Test Firm Registration Number: 446626)

TA Technology (Shanghai) Co., Ltd. has been listed on the US Federal Communications Commission list of test facilities recognized to perform electromagnetic emissions measurements.

IC (recognition number is 8510A)

TA Technology (Shanghai) Co., Ltd. has been listed by industry Canada to perform electromagnetic emission measurement.

VCCI (recognition number is C-4595, T-2154, R-4113, G-10766)

TA Technology (Shanghai) Co., Ltd. has been listed by industry Japan to perform electromagnetic emission measurement.

A2LA (Certificate Number: 3857.01)

TA Technology (Shanghai) Co., Ltd. has been listed by American Association for Laboratory Accreditation to perform electromagnetic emission measurement.



1.3. Testing Location

Company: TA Technology (Shanghai) Co., Ltd.
Address: No.145, Jintang Rd, Tangzhen Industry Park, Pudong
City: Shanghai
Post code: 201201
Country: P. R. China
Contact: Xu Kai
Telephone: +86-021-50791141/2/3
Fax: +86-021-50791141/2/3-8000
Website: <http://www.ta-shanghai.com>
E-mail: xukai@ta-shanghai.com



2. General Description of Equipment under Test

Client Information

Applicant	Xiaomi Communications Co., Ltd.
Applicant address	The Rainbow City of China Resources,NO.68,Qinghe Middle Street,Haidian District,Beijing,China
Manufacturer	Xiaomi Communications Co., Ltd.
Manufacturer address	The Rainbow City of China Resources,NO.68,Qinghe Middle Street,Haidian District,Beijing,China

General information

EUT Description	
Model	M1908C3JG
IMEI:	IMEI 1: 862384040008778 IMEI 2: 862384040012366
Hardware Version	P1.1
Software Version	MIUI 10
Power Supply	Battery/AC adapter
Antenna Type	Fixed Internal Antenna
Antenna Gain	5.15~5.25GHz:1.52dBi 5.25~5.35GHz:1.03dBi 5.47~5.725GHz:1.16dBi 5.725~5.825GHz:1.02dBi
additional beamforming gain	NA
Test Mode(s)	U-NII-1(5150MHz-5250MHz) U-NII-2A(5250MHz-5350MHz) U-NII-2C(5470MHz-5725MHz with 5600MHz -5650MHz) U-NII-3(5725MHz-5825MHz)
Modulation Type	802.11a/n (HT20/HT40) : OFDM 802.11ac (VHT20/VHT40/VHT80): OFDM
Max. Conducted Power	15.42dBm
Operating Frequency Range(s)	U-NII-1: 5150-5250MHz U-NII-2A:5250-5350MHz U-NII-2C:5470-5725MHz (with 5600MHz -5650MHz) U-NII-3: 5725-5825MHz
Operating temperature range:	0 ° C to 40° C
Operating voltage range:	3.65 V to 4.4 V



State DC voltage:	3.85V
EUT Accessory	
Adapter	Manufacturer: Jiangsu Chenyang Electron Co., Ltd. Model: MDY-09-EQ
Battery	Manufacturer: CosMX Model: BN46
USB Cable 1	Manufacturer: LUXSHARE Precision Industry Co., Ltd. Model: L23312 100cm Cable, Shielded
USB Cable 2	Manufacturer: SU ZHOU KELI SCIENCE&TECHNOLOGY DEVELOPMENT CO.,LTD Model: K23312 100cm Cable, Shielded
Note: 1.The information of the EUT is declared by the manufacturer.	



3. Applied Standards

According to the specifications of the manufacturer, it must comply with the requirements of the following standards:

FCC CFR47 Part 15E (2018) Unlicensed National Information Infrastructure Devices

ANSI C63.10 (2013)

KDB 789033 D02 General UNII Test Procedures New Rules v02r01



4. Test Configuration

Test Mode

The EUT has been associated with peripherals and configuration operated in a manner tended to maximize its emission characteristics in a typical application.

The radiated emission was measured in the following position: EUT stand-up position (Z axis), lie-down position (X, Y axis). The worst emission was found in lie-down position (X axis) and the worst case was recorded.

In order to find the worst case condition, Pre-tests are needed at the presence of different data rate. Preliminary tests have been done on all the configuration for confirming worst case. Data rate below means worst-case rate of each test item.

Worst-case data rates are shown as following table.

Band	Data Rate
802.11a	54 Mbps
802.11n HT20	MCS7
802.11n HT40	MCS0
802.11ac VHT20	MCS7
802.11ac VHT40	MCS0
802.11ac VHT80	MCS0



Wireless Technology and Frequency Range

Wireless Technology		Bandwidth	Channel	Frequency	
Wi-Fi	U-NII-1	20 MHz	36	5180MHz	
			40	5200MHz	
			44	5220MHz	
			48	5240MHz	
		40 MHz	38	5190MHz	
			46	5230MHz	
			80 MHz	42	5210MHz
		U-NII-2A	20 MHz	52	5260MHz
				56	5280MHz
	60			5300MHz	
	64			5320MHz	
	40 MHz		54	5270MHz	
			62	5310MHz	
			80 MHz	58	5290MHz
	U-NII-2C		20 MHz	100	5500MHz
				104	5520MHz
		108		5540MHz	
		112		5560MHz	
		116		5580MHz	
		120		5600MHz	
		124		5620MHz	
		128		5640MHz	
		132		5660MHz	
		136		5680MHz	
		140		5700MHz	
		40 MHz		102	5510MHz
			110	5550MHz	
			118	5590MHz	
			126	5630MHz	
			134	5670MHz	
142			5710MHz		
80 MHz		106	5530MHz		
		122	5610MHz		
		138	5690MHz		
U-NII-3		20 MHz	149	5745MHz	
	153		5765MHz		
	157		5785MHz		



			161	5805MHz
			165	5825MHz
		40 MHz	151	5755MHz
			159	5795MHz
		80 MHz	155	5775MHz
Does this device support TPC Function? <input type="checkbox"/> Yes <input checked="" type="checkbox"/> No				
Does this device support TDWR Band? <input checked="" type="checkbox"/> Yes <input type="checkbox"/> No				

5. Test Case Results

5.1. Occupied Bandwidth

Ambient condition

Temperature	Relative humidity	Pressure
23°C ~25°C	45%~50%	101.5kPa

Method of Measurement

The EUT was connected to the spectrum analyzer through an external attenuator (20dB) and a known loss cable.

For U-NII-1/U-NII-2A/U-NII-2C, set RBW \approx 1% OCB kHz, VBW \geq 3 \times RBW, measure the maximum width of the emission that is constrained by the frequencies associated with the two outermost amplitude points (upper and lower frequencies) that are attenuated by 26 dB relative to the maximum level measured in the fundamental emission.

For U-NII-3, Set RBW = 100 kHz, VBW \geq 3 \times RBW, measure the maximum width of the emission that is constrained by the frequencies associated with the two outermost amplitude points (upper and lower frequencies) that are attenuated by 6 dB relative to the maximum level measured in the fundamental emission.

Note: The automatic bandwidth measurement capability of a spectrum analyzer or EMI receiver may be employed if it implements the functionality described above.

Use the 99 % power bandwidth function of the instrument

Test Setup

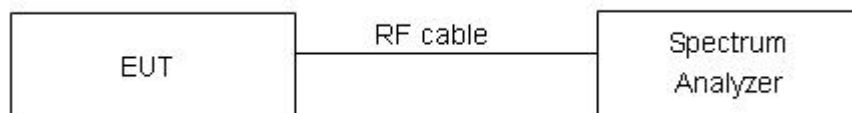

Limits

Rule FCC Part §15.407(e)

Within the 5.725-5.85 GHz band, the minimum 6 dB bandwidth of U-NII devices shall be at least 500 kHz.

Measurement Uncertainty

The assessed measurement uncertainty to ensure 95% confidence level for the normal distribution is with the coverage factor $k = 2$, $U = 936$ Hz.

**Test Results:****U-NII-1**

Network Standards	Carrier frequency (MHz)	99% bandwidth (MHz)	Minimum 26 dB bandwidth (MHz)	Conclusion
802.11a	5180	16.647	24.70	PASS
	5200	16.630	23.07	PASS
	5240	16.566	22.30	PASS
802.11n HT20	5180	17.773	21.53	PASS
	5200	17.773	22.58	PASS
	5240	17.776	21.58	PASS
802.11n HT40	5190	36.211	40.78	PASS
	5230	36.325	40.91	PASS
802.11ac VHT20	5180	17.728	24.14	PASS
	5200	17.779	24.08	PASS
	5240	17.769	23.78	PASS
802.11ac VHT40	5190	36.171	40.98	PASS
	5230	36.200	41.21	PASS
802.11ac VHT80	5210	75.562	82.08	PASS

U-NII-2A

Network Standards	Carrier frequency (MHz)	99% bandwidth (MHz)	Minimum 26 dB bandwidth (MHz)	Conclusion
802.11a	5260	16.613	23.33	PASS
	5300	16.716	23.20	PASS
	5320	16.626	23.40	PASS
802.11n HT20	5260	17.747	22.67	PASS
	5300	17.723	22.81	PASS
	5320	17.752	23.24	PASS
802.11n HT40	5270	36.240	41.32	PASS
	5310	36.189	41.00	PASS
802.11ac VHT20	5260	17.766	23.33	PASS
	5300	17.705	22.66	PASS
	5320	17.731	22.84	PASS
802.11ac VHT40	5270	36.202	41.11	PASS
	5310	36.169	40.42	PASS
802.11ac VHT80	5290	75.569	82.41	PASS



U-NII-2C

Network Standards	Carrier frequency (MHz)	99% bandwidth (MHz)	Minimum 26 dB bandwidth (MHz)	Conclusion
802.11a	5500	16.645	24.91	PASS
	5580	16.605	23.39	PASS
	5700	16.629	22.79	PASS
802.11n HT20	5500	17.750	23.56	PASS
	5580	17.726	23.83	PASS
	5700	17.764	22.76	PASS
802.11n HT40	5510	36.270	41.20	PASS
	5550	36.189	40.59	PASS
	5670	36.248	41.56	PASS
802.11ac VHT20	5500	17.729	23.00	PASS
	5580	17.736	23.38	PASS
	5700	17.740	23.09	PASS
802.11ac VHT40	5510	36.284	40.92	PASS
	5550	36.220	41.21	PASS
	5670	36.275	40.85	PASS
802.11ac VHT80	5530	75.536	82.78	PASS

U-NII-3

Network Standards	Carrier frequency (MHz)	99% bandwidth (MHz)	Minimum 6 dB bandwidth (MHz)	Limit (kHz)	Conclusion
802.11a	5745	16.686	15.75	500	PASS
	5785	16.644	16.33	500	PASS
	5825	16.638	15.13	500	PASS
802.11n HT20	5745	17.734	17.61	500	PASS
	5785	17.784	13.17	500	PASS
	5825	17.764	15.10	500	PASS
802.11n HT40	5755	36.112	35.50	500	PASS
	5795	36.249	36.08	500	PASS
802.11ac VHT20	5745	17.740	12.84	500	PASS
	5785	17.763	15.62	500	PASS
	5825	17.686	17.18	500	PASS
802.11ac VHT40	5755	36.151	35.14	500	PASS
	5795	36.260	35.08	500	PASS
802.11ac VHT80	5775	75.509	75.69	500	PASS



U-NII-1, 802.11a
Carrier frequency (MHz): 5180



U-NII-1, 802.11n HT20
Carrier frequency (MHz): 5180



U-NII-1, 802.11a
Carrier frequency (MHz): 5200



U-NII-1, 802.11n HT20
Carrier frequency (MHz): 5200

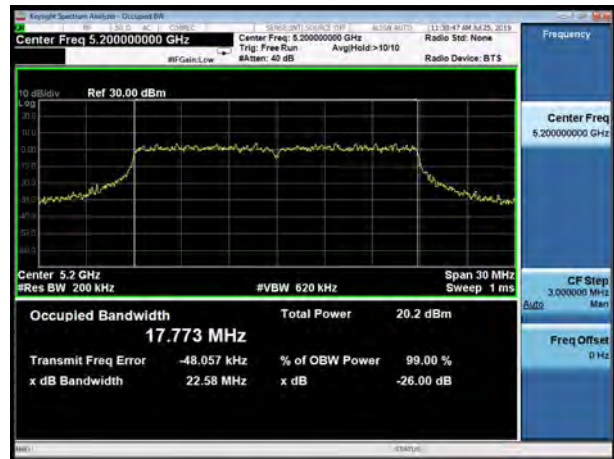

U-NII-1, 802.11a
Carrier frequency (MHz): 5240

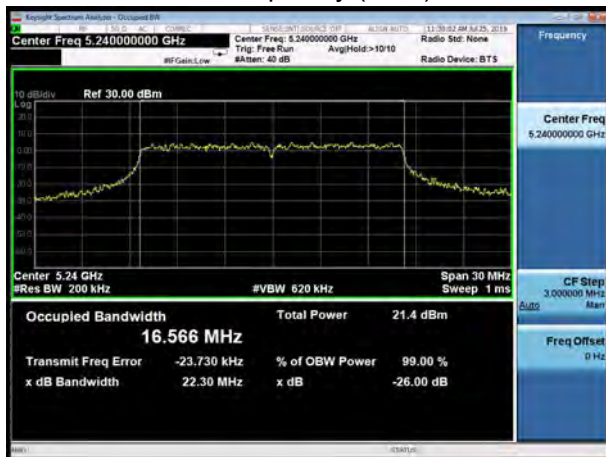

U-NII-1, 802.11n HT20
Carrier frequency (MHz): 5240



U-NII-1, 802.11n HT40
Carrier frequency (MHz): 5190



U-NII-1, 802.11ac VHT20
Carrier frequency (MHz): 5180



U-NII-1, 802.11n HT40
Carrier frequency (MHz): 5230



U-NII-1, 802.11ac VHT20
Carrier frequency (MHz): 5200



U-NII-1, 802.11ac VHT40
Carrier frequency (MHz): 5190



U-NII-1, 802.11ac VHT20
Carrier frequency (MHz): 5240





U-NII-1, 802.11ac VHT40
Carrier frequency (MHz): 5230



U-NII-1, 802.11ac VHT80
Carrier frequency (MHz): 5210



U-NII-2A, 802.11a
Carrier frequency (MHz): 5260



U-NII-2A, 802.11n HT20
Carrier frequency (MHz): 5260



U-NII-2A, 802.11a
Carrier frequency (MHz): 5300



U-NII-2A, 802.11n HT20
Carrier frequency (MHz): 5300



U-NII-2A, 802.11a
Carrier frequency (MHz):5320



U-NII-2A, 802.11n HT20
Carrier frequency (MHz):5320



U-NII-2A, 802.11n HT40
Carrier frequency (MHz): 5270



U-NII-2A, 802.11ac VHT20
Carrier frequency (MHz):5260



U-NII-2A, 802.11n HT40
Carrier frequency (MHz): 5310



U-NII-2A, 802.11ac VHT20
Carrier frequency (MHz): 5300



U-NII-2A, 802.11ac VHT40
Carrier frequency (MHz): 5270



U-NII-2A, 802.11ac VHT20
Carrier frequency (MHz): 5320



U-NII-2A, 802.11ac VHT40
Carrier frequency (MHz): 5310



U-NII-2A, 802.11ac VHT80
Carrier frequency (MHz): 5290

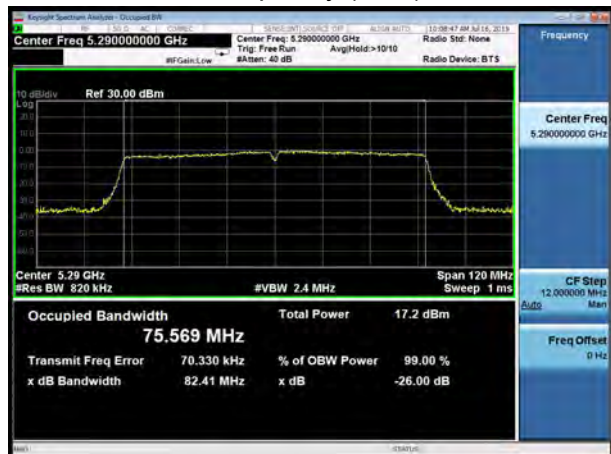

U-NII-2C, 802.11a
Carrier frequency (MHz): 5500



U-NII-2C, 802.11n HT20
Carrier frequency (MHz): 5500





U-NII-2C, 802.11n HT40
Carrier frequency (MHz): 5550



U-NII-2C, 802.11ac VHT40
Carrier frequency (MHz): 5550



U-NII-2C, 802.11ac VHT40
Carrier frequency (MHz): 5670





99% bandwidth

U-NII-3, 802.11a
Carrier frequency (MHz): 5745



U-NII-3, 802.11n HT20
Carrier frequency (MHz): 5745

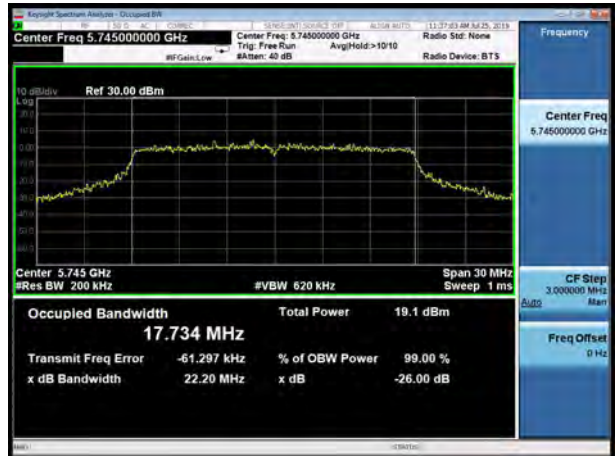

U-NII-3, 802.11a
Carrier frequency (MHz): 5785



U-NII-3, 802.11n HT20
Carrier frequency (MHz): 5785



U-NII-3, 802.11a
Carrier frequency (MHz): 5825



U-NII-3, 802.11n HT20
Carrier frequency (MHz): 5825





U-NII-3, 802.11n HT40
Carrier frequency (MHz): 5755



U-NII-3, 802.11ac VHT20
Carrier frequency (MHz): 5745



U-NII-3, 802.11n HT40
Carrier frequency (MHz): 5795



U-NII-3, 802.11ac VHT20
Carrier frequency (MHz): 5785



U-NII-3, 802.11ac VHT40
Carrier frequency (MHz): 5755



U-NII-3, 802.11ac VHT20
Carrier frequency (MHz): 5825





U-NII-3, 802.11ac VHT40
Carrier frequency (MHz): 5795



U-NII-3, 802.11ac VHT80
Carrier frequency (MHz): 5775





Minimum 6 dB bandwidth

U-NII-3, 802.11a

Carrier frequency (MHz): 5745



U-NII-3, 802.11n HT20

Carrier frequency (MHz): 5745

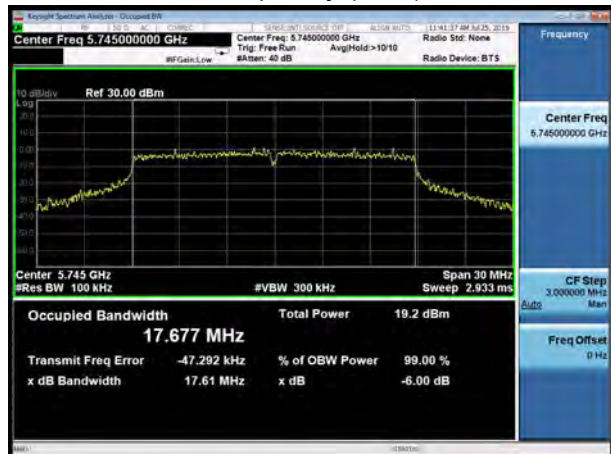

U-NII-3, 802.11a

Carrier frequency (MHz): 5785

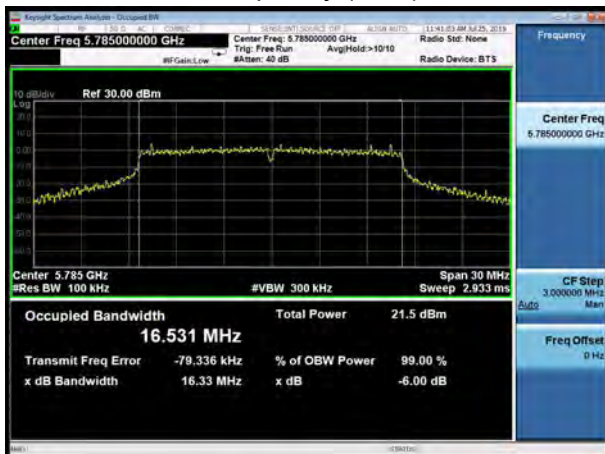

U-NII-3, 802.11n HT20

Carrier frequency (MHz): 5785



U-NII-3, 802.11a

Carrier frequency (MHz): 5825



U-NII-3, 802.11n HT20

Carrier frequency (MHz): 5825





U-NII-3, 802.11n HT40
Carrier frequency (MHz): 5755



U-NII-3, 802.11ac VHT20
Carrier frequency (MHz): 5745

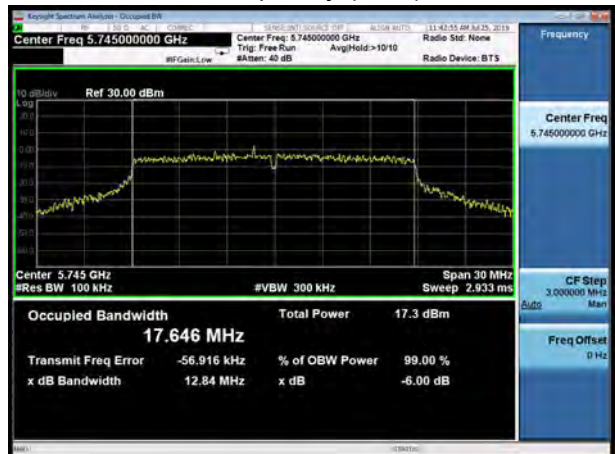

U-NII-3, 802.11n HT40
Carrier frequency (MHz): 5795



U-NII-3, 802.11ac VHT20
Carrier frequency (MHz): 5785



U-NII-3, 802.11ac VHT40
Carrier frequency (MHz): 5755



U-NII-3, 802.11ac VHT20
Carrier frequency (MHz): 5825





U-NII-3, 802.11ac VHT40
Carrier frequency (MHz): 5795



U-NII-3, 802.11ac VHT80
Carrier frequency (MHz): 5775



5.2. Average Power Output –Conducted

Ambient condition

Temperature	Relative humidity	Pressure
23°C ~25°C	45%~50%	101.5kPa

Methods of Measurement

During the process of the testing, The EUT was connected to the average power meter through an external attenuator and a known loss cable. The EUT is max power transmission with proper modulation. We use Maximum average Conducted Output Power Level Method in KDB789033 for this test

Test Setup

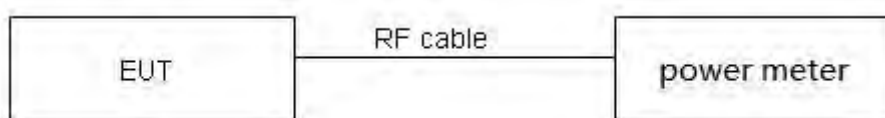

Limits

Rule FCC Part 15.407(a)(1)(2)(3)

(1) For the band 5.15-5.25 GHz.

(i) For an outdoor access point operating in the band 5.15-5.25 GHz, the maximum conducted output power over the frequency band of operation shall not exceed 1 W provided the maximum antenna gain does not exceed 6 dBi. In addition, the maximum power spectral density shall not exceed 17 dBm in any 1 megahertz band. If transmitting antennas of directional gain greater than 6 dBi are used, both the maximum conducted output power and the maximum power spectral density shall be reduced by the amount in dB that the directional gain of the antenna exceeds 6 dBi. The maximum e.i.r.p. at any elevation angle above 30 degrees as measured from the horizon must not exceed 125 mW (21 dBm).

(ii) For an indoor access point operating in the band 5.15-5.25 GHz, the maximum conducted output power over the frequency band of operation shall not exceed 1 W provided the maximum antenna gain does not exceed 6 dBi. In addition, the maximum power spectral density shall not exceed 17 dBm in any 1 megahertz band. If transmitting antennas of directional gain greater than 6 dBi are used, both the maximum conducted output power and the maximum power spectral density shall be reduced by the amount in dB that the directional gain of the antenna exceeds 6 dBi.

(iii) For fixed point-to-point access points operating in the band 5.15-5.25 GHz, the maximum conducted output power over the frequency band of operation shall not exceed 1 W. In addition, the maximum power spectral density shall not exceed 17 dBm in any 1 megahertz band. Fixed point-to-point U-NII devices may employ antennas with directional gain up to 23 dBi without any corresponding reduction in the maximum conducted output power or maximum power spectral density. For fixed point-to-point transmitters that employ a directional antenna gain greater than 23 dBi, a 1 dB reduction in maximum conducted output power and maximum power spectral density is required for each 1 dB of antenna gain in excess of 23 dBi. Fixed, point-to-point operations exclude



the use of point-to-multipoint systems, omnidirectional applications, and multiple collocated transmitters transmitting the same information. The operator of the U-NII device, or if the equipment is professionally installed, the installer, is responsible for ensuring that systems employing high gain directional antennas are used exclusively for fixed, point-to-point operations.

(iv) For client devices in the 5.15-5.25 GHz band, the maximum conducted output power over the frequency band of operation shall not exceed 250 mW provided the maximum antenna gain does not exceed 6 dBi. In addition, the maximum power spectral density shall not exceed 11 dBm in any 1 megahertz band. If transmitting antennas of directional gain greater than 6 dBi are used, both the maximum conducted output power and the maximum power spectral density shall be reduced by the amount in dB that the directional gain of the antenna exceeds 6 dBi.

(2) For the 5.25-5.35 GHz and 5.47-5.725 GHz bands, the maximum conducted output power over the frequency bands of operation shall not exceed the lesser of 250 mW or $11 \text{ dBm} + 10 \log B$, where B is the 26 dB emission bandwidth in megahertz. In addition, the maximum power spectral density shall not exceed 11 dBm in any 1 megahertz band. If transmitting antennas of directional gain greater than 6 dBi are used, both the maximum conducted output power and the maximum power spectral density shall be reduced by the amount in dB that the directional gain of the antenna exceeds 6 dBi.

(3) For the band 5.725-5.85 GHz, the maximum conducted output power over the frequency band of operation shall not exceed 1 W. In addition, the maximum power spectral density shall not exceed 30 dBm in any 500-kHz band. If transmitting antennas of directional gain greater than 6 dBi are used, both the maximum conducted output power and the maximum power spectral density shall be reduced by the amount in dB that the directional gain of the antenna exceeds 6 dBi.

Measurement Uncertainty

The assessed measurement uncertainty to ensure 95% confidence level for the normal distribution is with the coverage factor $k = 2$, $U = 0.44 \text{ dB}$.



Test Results

Band	T _{on} (ms)	T _(on+off) (ms)	Duty cycle	Duty cycle correction Factor(dB)
802.11a	2.03	2.06	0.98	NA
802.11n HT20	1.89	1.92	0.98	NA
802.11n HT40	0.93	0.96	0.96	0.17
802.11ac VHT20	1.90	1.94	0.98	0.00
802.11ac VHT40	0.94	0.97	0.96	0.16
802.11ac VHT80	0.46	0.49	0.93	0.33

Note: when Duty cycle>0.98, Duty cycle correction Factor not required.

Single Antenna Power Index												
Packet Type	CH36	CH40	CH48	CH52	CH60	CH64	CH 100	CH 120	CH 140	CH 149	CH 157	CH 165
802.11a	16	16	16	16	16	16	16	16	16	16	16	16
802.11n HT20	14	14	14	14	14	14	14	14	14	14	14	14
802.11ac VHT20	12	12	12	12	12	12	12	12	12	12	12	12
Packet Type	CH38	CH46	CH54	CH62	CH 102	CH 118	CH 134	CH 151	CH 159	/	/	/
802.11n HT40	14	14	14	14	14	14	14	14	14	/	/	/
802.11ac VHT40	12	12	12	12	12	12	12	12	12	/	/	/
Packet Type	CH42	CH58	CH 122	CH 155	/	/	/	/	/	/	/	/
802.11ac VHT80	12	12	12	12	/	/	/	/	/	/	/	/



Network Standards		Channel/Frequency (MHz)	B=26 dB bandwidth (MHz)	Limit 11 dBm + 10 log B (dBm)	Final Limit(dBm)	
U-NII-2A	802.11a	52/5260	23.30	24.67>24	24	
		60/5300	23.20	24.65>24	24	
		64/5320	23.40	24.69>24	24	
	802.11n HT20	52/5260	22.67	24.55>24	24	
		60/5300	22.81	24.58>24	24	
		64/5320	23.24	24.66>24	24	
	802.11n HT40	54/5270	41.32	27.16>24	24	
		62/5310	41.00	27.13>24	24	
	802.11ac VHT20	52/5260	22.33	24.49>24	24	
		60/5300	22.66	24.55>24	24	
		64/5320	22.84	24.59>24	24	
	802.11ac VHT40	54/5270	41.11	27.14>24	24	
		62/5310	40.42	27.07>24	24	
802.11ac VHT80	58/5290	82.41	30.16>24	24		
U-NII-2C	802.11a	100/5500	24.91	24.96>24	24	
		116/5580	23.39	24.69>24	24	
		140/5700	22.79	24.58>24	24	
	802.11n HT20	100/5500	23.56	24.72>24	24	
		116/5580	23.83	24.77>24	24	
		140/5700	22.76	24.57>24	24	
	802.11n HT40	102/5510	41.20	27.15 >24	24	
		110/5550	40.59	27.08 >24	24	
		134/5670	41.56	27.19>24	24	
	802.11ac VHT20	100/5500	23.00	24.62>24	24	
		116/5580	23.38	24.69>24	24	
		140/5700	23.09	24.63>24	24	
	802.11ac VHT40	102/5510	40.92	27.12>24	24	
		110/5550	41.21	27.15>24	24	
		134/5670	40.85	27.11>24	24	
	802.11ac VHT80	106/5530	82.78	30.18>24	24	
	Note: 250mW=24dBm					



Note: Average Power with duty factor = Average Power Measured +Duty cycle correction factor

U-NII-1

Network Standards	Channel/ Frequency (MHz)	Average Power Measured (dBm)	Average Power with duty factor (dBm)	Limit (dBm)	Conclusion
802.11a	36/5180	15.42	15.42	24	PASS
	40/5200	14.98	14.98	24	PASS
	48/5240	14.75	14.75	24	PASS
802.11n HT20	36/5180	13.33	13.33	24	PASS
	40/5200	13.02	13.02	24	PASS
	48/5240	12.76	12.76	24	PASS
802.11n HT40	38/5190	13.89	14.06	24	PASS
	46/5230	13.31	13.48	24	PASS
802.11ac VHT20	36/5180	11.42	11.42	24	PASS
	40/5200	11.24	11.24	24	PASS
	48/5240	11.01	11.01	24	PASS
802.11ac VHT40	38/5190	12.02	12.18	24	PASS
	46/5230	11.62	11.78	24	PASS
802.11ac VHT80	42/5210	11.47	11.80	24	PASS

Note: Average Power with duty factor = Average Power Measured +Duty cycle correction factor



U-NII-2A

Network Standards	Channel/ Frequency (MHz)	Average Power Measured (dBm)	Average Power with duty factor (dBm)	Limit (dBm)	Conclusion
802.11a	52/5260	15.03	15.03	24.00	PASS
	60/5300	14.94	14.94	24.00	PASS
	64/5320	14.89	14.89	24.00	PASS
802.11n HT20	52/5260	12.97	12.97	24.00	PASS
	60/5300	13.03	13.03	24.00	PASS
	64/5320	12.89	12.89	24.00	PASS
802.11n HT40	54/5270	13.38	13.55	24.00	PASS
	62/5310	13.44	13.61	24.00	PASS
802.11ac VHT20	52/5260	11.14	11.14	24.00	PASS
	60/5300	11.37	11.37	24.00	PASS
	64/5320	11.29	11.29	24.00	PASS
802.11ac VHT40	54/5270	11.76	11.92	24.00	PASS
	62/5310	11.83	11.99	24.00	PASS
802.11ac VHT80	58/5290	11.28	11.61	24.00	PASS

Note: Average Power with duty factor = Average Power Measured +Duty cycle correction factor

U-NII-2C

Network Standards	Channel/ Frequency (MHz)	Average Power Measured (dBm)	Average Power with duty factor (dBm)	Limit (dBm)	Conclusion
802.11a	100/5500	15.13	15.13	24.00	PASS
	116/5580	15.21	15.21	24.00	PASS
	140/5700	14.82	14.82	24.00	PASS
802.11n HT20	100/5500	13.12	13.12	24.00	PASS
	116/5580	13.34	13.34	24.00	PASS
	140/5700	13.25	13.25	24.00	PASS
802.11n HT40	102/5510	13.74	13.91	24.00	PASS
	110/5550	13.98	14.15	24.00	PASS
	134/5670	13.66	13.83	24.00	PASS
802.11ac VHT20	100/5500	11.42	11.42	24.00	PASS
	116/5580	11.53	11.53	24.00	PASS
	140/5700	11.24	11.24	24.00	PASS
802.11ac	102/5510	11.86	12.02	24.00	PASS



VHT40	110/5550	12.09	12.25	24.00	PASS
	134/5670	11.78	11.94	24.00	PASS
802.11ac VHT80	122/5610	11.55	11.88	24.00	PASS

Note: Average Power with duty factor = Average Power Measured +Duty cycle correction factor

U-NII-3

Network Standards	Channel/ Frequency (MHz)	Average Power Measured (dBm)	Average Power with duty factor (dBm)	Limit (dBm)	Conclusion
802.11a	149/5745	15.11	15.11	30	PASS
	157/5785	15.23	15.23	30	PASS
	165/5825	15.24	15.24	30	PASS
802.11n HT20	149/5745	13.22	13.22	30	PASS
	157/5785	13.65	13.65	30	PASS
	165/5825	13.53	13.53	30	PASS
802.11n HT40	151/5755	13.85	14.02	30	PASS
	159/5795	13.91	14.08	30	PASS
802.11ac VHT20	149/5745	11.43	11.43	30	PASS
	157/5785	11.75	11.75	30	PASS
	165/5825	11.64	11.64	30	PASS
802.11ac VHT40	151/5755	11.93	12.09	30	PASS
	159/5795	12.11	12.27	30	PASS
802.11ac VHT80	155/5775	11.75	12.08	30	PASS

Note: Average Power with duty factor = Average Power Measured +Duty cycle correction factor

5.3. Frequency Stability

Ambient condition

Temperature	Relative humidity	Pressure
23°C ~25°C	45%~50%	101.5kPa

Method of Measurement

1. Frequency stability with respect to ambient temperature

a) Supply the EUT with a nominal ac voltage or install a new or fully charged battery in the EUT. If possible, a dummy load shall be connected to the EUT because an antenna near the metallic walls of an environmental test chamber could affect the output frequency of the EUT. If the EUT is equipped with a permanently attached, adjustable-length antenna, then the EUT shall be placed in the center of the chamber with the antenna adjusted to the shortest length possible. Turn ON the EUT and tune it to one of the number of frequencies shown in 5.6.

b) Couple the unlicensed wireless device output to the measuring instrument by connecting an antenna to the measuring instrument with a suitable length of coaxial cable and placing the measuring antenna near the EUT (e.g., 15 cm away), or by connecting a dummy load to the measuring instrument, through an attenuator if necessary.

c) Adjust the location of the measurement antenna and the controls on the measurement instrument to obtain a suitable signal level (i.e., a level that will not overload the measurement instrument but is strong enough to allow measurement of the operating or fundamental frequency of the EUT).

d) Turn the EUT OFF and place it inside the environmental temperature chamber. For devices that have oscillator heaters, energize only the heater circuit.

e) Set the temperature control on the chamber to the highest specified in the regulatory requirements for the type of device and allow the oscillator heater and the chamber temperature to stabilize.

f) While maintaining a constant temperature inside the environmental chamber, turn the EUT ON and record the operating frequency at startup, and at 2 minutes, 5 minutes, and 10 minutes after the EUT is energized. Four measurements in total are made.

g) Measure the frequency at each of frequencies specified in 5.6.

h) Switch OFF the EUT but do not switch OFF the oscillator heater.

i) Lower the chamber temperature by not more than 10°C, and allow the temperature inside the chamber to stabilize.

j) Repeat step f) through step i) down to the lowest specified temperature.

2. Frequency stability when varying supply voltage

Unless otherwise specified, these tests shall be made at ambient room temperature (+15°C to +25°C). An antenna shall be connected to the antenna output terminals of the EUT if possible. If the EUT is equipped with or uses an adjustable-length antenna, then it shall be fully extended.

a) Supply the EUT with nominal voltage or install a new or fully charged battery in the EUT. Turn ON the EUT and couple its output to a frequency counter or other frequency-measuring instrument.



- b) Tune the EUT to one of the number of frequencies required in 5.6. Adjust the location of the measurement antenna and the controls on the measurement instrument to obtain a suitable signal level (i.e., a level that will not overload the measurement instrument but is strong enough to allow measurement of the operating or fundamental frequency of the EUT).
- c) Measure the frequency at each of the frequencies specified in 5.6.
- d) Repeat the above procedure at 85% and 115% of the nominal supply voltage.

Limit

Manufacturers of U-NII devices are responsible for ensuring frequency stability such that an emission is maintained within the band of operation under all conditions of normal operation as specified in the users manual.

Measurement Uncertainty

The assessed measurement uncertainty to ensure 95% confidence level for the normal distribution is with the coverage factor $k = 2$, $U = 936\text{Hz}$

**Test Results**

Voltage (V)	Temperature (°C)	U-NII-1 Test Results			
		5200MHz			
		1min	2min	5min	10min
3.85V	-10	5199.995445	5199.992871	5199.986835	5199.983398
3.85V	0	5200.000478	5199.988165	5199.983602	5199.977908
3.85V	10	5199.998065	5199.978600	5199.980753	5199.969454
3.85V	20	5199.988085	5199.976038	5199.971911	5199.966122
3.85V	30	5199.982768	5199.975558	5199.962298	5199.956980
3.85V	40	5199.978434	5199.975065	5199.960870	5199.948778
3.85V	50	5199.969408	5199.971317	5199.957284	5199.946786
3.85V	55	5199.963125	5199.970485	5199.955237	5199.942461
3.65V	20	5199.960255	5199.963731	5199.948947	5199.939590
4.4V	20	5199.958905	5199.955482	5199.940862	5199.931029
MHz		-0.041095	-0.044518	-0.059138	-0.068971
PPM		-7.902839	-8.561109	-11.372644	-13.263663

Voltage (V)	Temperature (°C)	U-NII-2A Test Results			
		5300MHz			
		1min	2min	5min	10min
3.85V	-10	5299.994365	5299.993243	5299.985922	5299.980364
3.85V	0	5299.984544	5299.989913	5299.984882	5299.976742
3.85V	10	5299.976957	5299.988491	5299.983938	5299.967308
3.85V	20	5299.968335	5299.987036	5299.981813	5299.967245
3.85V	30	5299.964984	5299.981444	5299.978804	5299.964388
3.85V	40	5299.960961	5299.974811	5299.971954	5299.961167
3.85V	50	5299.952391	5299.969755	5299.971672	5299.959938
3.85V	55	5299.943486	5299.965443	5299.963399	5299.952881
3.65V	20	5299.941294	5299.955673	5299.962895	5299.949874
4.4V	20	5299.936268	5299.952362	5299.954926	5299.939964
MHz		-0.063732	-0.047638	-0.045074	-0.060036
PPM		-12.024981	-8.988366	-8.504527	-11.327625



Voltage (V)	Temperature (°C)	U-NII-2C Test Results			
		5580MHz			
		1min	2min	5min	10min
3.85V	-10	5579.992663	5579.990779	5579.985421	5579.984473
3.85V	0	5579.987644	5579.985142	5579.980957	5579.983520
3.85V	10	5579.985654	5579.982648	5579.975291	5579.976725
3.85V	20	5579.977866	5579.974339	5579.973189	5579.967221
3.85V	30	5579.974642	5579.965871	5579.966265	5579.959483
3.85V	40	5579.969134	5579.964438	5579.965723	5579.954066
3.85V	50	5579.968730	5579.963488	5579.955842	5579.948521
3.85V	55	5579.959862	5579.963105	5579.954563	5579.943125
3.65V	20	5579.956181	5579.958655	5579.953985	5579.943000
4.4V	20	5579.946530	5579.957009	5579.945465	5579.935751
	MHz	-0.053470	-0.042991	-0.054535	-0.064249
	PPM	-9.582353	-7.704509	-9.773272	-11.514115

Voltage (V)	Temperature (°C)	U-NII-3 Test Results			
		5785MHz			
		1min	2min	5min	10min
3.85V	-10	5784.990660	5784.982836	5784.976945	5784.976822
3.85V	0	5784.982663	5784.976853	5784.973665	5784.976627
3.85V	10	5784.980189	5784.968945	5784.968882	5784.970148
3.85V	20	5784.975219	5784.965573	5784.960485	5784.963440
3.85V	30	5784.969558	5784.957886	5784.958643	5784.959691
3.85V	40	5784.961584	5784.948943	5784.956121	5784.955558
3.85V	50	5784.955953	5784.941324	5784.946363	5784.953370
3.85V	55	5784.954748	5784.937128	5784.944735	5784.947736
3.65V	20	5784.950751	5784.933721	5784.939242	5784.943724
4.4V	20	5784.947308	5784.933214	5784.929291	5784.941853
	MHz	-0.052692	-0.066786	-0.070709	-0.058147
	PPM	-9.108355	-11.544753	-12.222839	-10.051409

5.4. Power Spectral Density

Ambient condition

Temperature	Relative humidity	Pressure
23°C ~25°C	45%~50%	101.5kPa

Method of Measurement

The EUT was connected to the spectrum analyzer through an external attenuator (20dB) and a known loss cable.

Set RBW = 500 kHz, VBW =1.5MHz for the band 5.725-5.85 GHz

Set RBW = 1 MHz, VBW =3MHz for the band 5.150-5.250 GHz

The conducted PSD is measured at each antenna port. The measured results at the various antenna ports are then summed mathematically.

Test setup

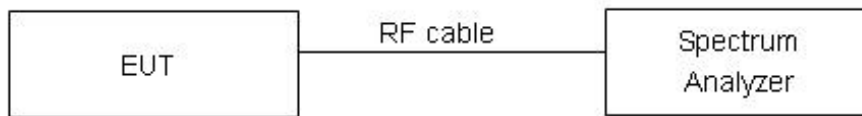

Limits

Rule FCC Part 15.407(a)(1)/ Part 15.407(a)(2) / Part 15.407(a)(3)

For an indoor access point operating in the band 5.15-5.25 GHz, the maximum power spectral density shall not exceed 17 dBm in any 1 megahertz band. If transmitting antennas of directional gain greater than 6 dBi are used, both the maximum conducted output power and the maximum power spectral density shall be reduced by the amount in dB that the directional gain of the antenna exceeds 6 dBi.

For the 5.25-5.35 GHz and 5.47-5.725 GHz bands, the maximum power spectral density shall not exceed 11 dBm in any 1 megahertz band. If transmitting antennas of directional gain greater than 6 dBi are used, both the maximum conducted output power and the maximum power spectral density shall be reduced by the amount in dB that the directional gain of the antenna exceeds 6 dBi.

For the band 5.725-5.85 GHz, the maximum power spectral density shall not exceed 30 dBm in any 500-kHz band. If transmitting antennas of directional gain greater than 6 dBi are used, both the maximum conducted output power and the maximum power spectral density shall be reduced by the amount in dB that the directional gain of the antenna exceeds 6 dBi.

Frequency Bands/MHz	Limits
5150-5250	17/11dBm/MHz
5.25-5.35 GHz and 5.47-5.725 GHz	11dBm/MHz
5725-5850	30dBm/500kHz



Measurement Uncertainty

The assessed measurement uncertainty to ensure 95% confidence level for the normal distribution is with the coverage factor $k = 2$, $U = 0.75\text{dB}$.

**Test Results:**

Note: Power Spectral Density =Read Value+Duty cycle correction factor

U-NII-1

Network Standards	Channel Number	Read Value (dBm /MHz)	Power Spectral Density (dBm /MHz)	Limit (dBm /MHz)	Conclusion
802.11a	36	4.37	4.37	11	PASS
	40	4.29	4.29	11	PASS
	48	3.79	3.79	11	PASS
802.11n HT20	36	2.24	2.24	11	PASS
	40	2.00	2.00	11	PASS
	48	1.18	1.18	11	PASS
802.11n HT40	38	0.54	0.71	11	PASS
	46	-1.19	-1.03	11	PASS
802.11ac VHT20	36	0.67	0.67	11	PASS
	40	0.29	0.29	11	PASS
	48	-0.40	-0.40	11	PASS
802.11ac VHT40	38	-1.53	-1.37	11	PASS
	46	-2.45	-2.28	11	PASS
802.11ac VHT80	42	-5.30	-4.97	11	PASS

U-NII-2A

Network Standards	Channel Number	Read Value (dBm /MHz)	Power Spectral Density (dBm /MHz)	Limit (dBm /MHz)	Conclusion
802.11a	52	3.55	3.55	11	PASS
	60	3.50	3.50	11	PASS
	64	3.18	3.18	11	PASS
802.11n HT20	52	1.58	1.58	11	PASS
	60	1.34	1.34	11	PASS
	64	1.02	1.02	11	PASS
802.11n HT40	54	-0.07	0.10	11	PASS
	62	-0.97	-0.80	11	PASS
802.11ac	52	-0.18	-0.18	11	PASS



VHT20	60	-0.35	-0.35	11	PASS
	64	-0.32	-0.32	11	PASS
802.11ac VHT40	54	-2.17	0.16	11	PASS
	62	-2.48	-2.31	11	PASS
802.11ac VHT80	58	-5.63	-5.30	11	PASS

U-NII-2C

Network Standards	Channel Number	Read Value (dBm /MHz)	Power Spectral Density (dBm /MHz)	Limit (dBm /MHz)	Conclusion
802.11a	100	4.29	4.29	11	PASS
	116	4.39	4.39	11	PASS
	140	4.42	4.42	11	PASS
802.11n HT20	100	2.08	2.08	11	PASS
	116	2.01	2.01	11	PASS
	140	2.36	2.36	11	PASS
802.11n HT40	102	0.22	0.39	11	PASS
	110	0.69	0.86	11	PASS
	134	0.25	0.42	11	PASS
802.11ac VHT20	100	0.13	0.13	11	PASS
	116	0.42	0.42	11	PASS
	140	0.74	0.74	11	PASS
802.11ac VHT40	102	-1.15	-0.99	11	PASS
	110	-1.19	-1.03	11	PASS
	134	-1.65	-1.49	11	PASS
802.11ac VHT80	122	-5.13	-4.80	11	PASS

U-NII-3

Network Standards	Channel Number	Read Value (dBm/500kHz)	Power Spectral Density (dBm/500kHz)	Limit (dBm/500kHz)	Conclusion
802.11a	149	1.42	1.42	30	PASS
	157	1.32	1.32	30	PASS
	165	1.37	1.37	30	PASS
802.11n HT20	149	-0.41	-0.41	30	PASS
	157	0.18	0.18	30	PASS



	165	-0.42	-0.42	30	PASS
802.11n HT40	151	-1.97	-1.80	30	PASS
	159	-2.71	-2.55	30	PASS
802.11ac VHT20	149	-2.32	-2.32	30	PASS
	157	-1.67	-1.67	30	PASS
	165	-3.04	-3.04	30	PASS
802.11ac VHT40	151	-3.62	-3.45	30	PASS
	159	-4.25	-4.09	30	PASS
802.11ac VHT80	155	-7.42	-7.09	30	PASS



U-NII-1, 802.11a, Channel No.: 36



U-NII-1, 802.11n HT20, Channel No.: 36

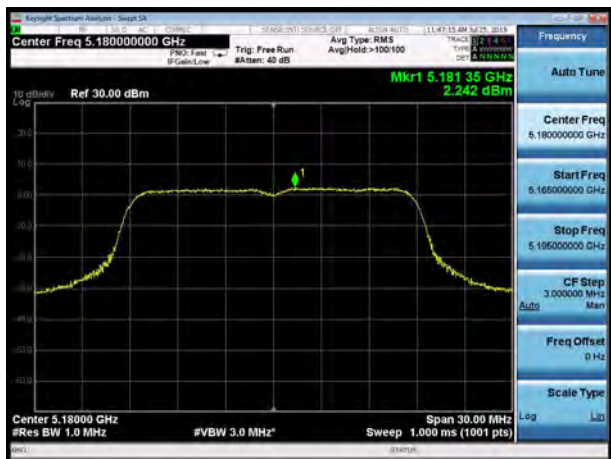

U-NII-1, 802.11a, Channel No.: 40



U-NII-1, 802.11n HT20, Channel No.: 40



U-NII-1, 802.11a, Channel No.: 48



U-NII-1, 802.11n HT20, Channel No.: 48

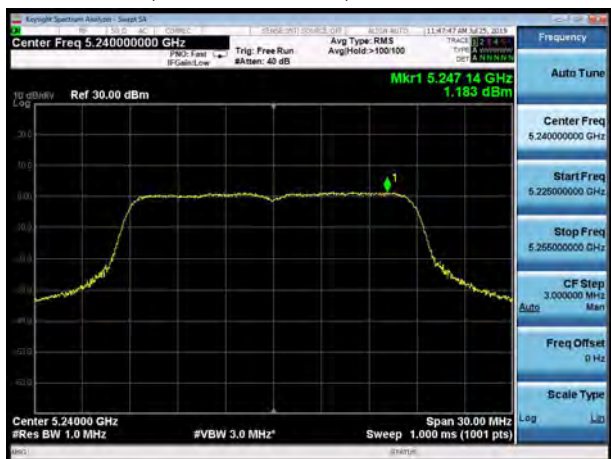



U-NII-1, 802.11n HT40, Channel No.: 38



U-NII-1, 802.11ac VHT20, Channel No.: 36



U-NII-1, 802.11n HT40, Channel No.: 46



U-NII-1, 802.11ac VHT20, Channel No.: 40



U-NII-1, 802.11ac VHT40, Channel No.: 38



U-NII-1, 802.11ac VHT20, Channel No.: 48

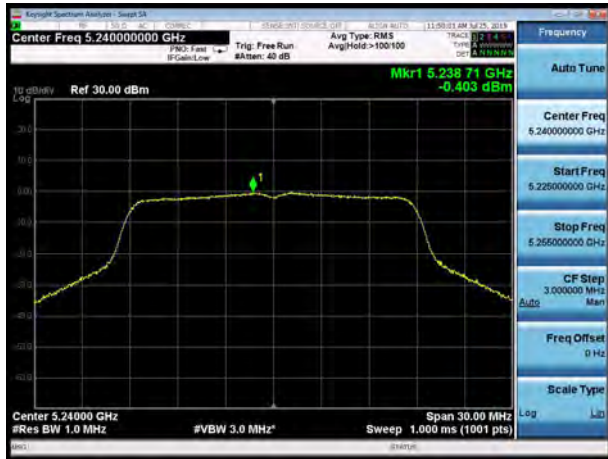



U-NII-1, 802.11ac VHT40, Channel No.: 46

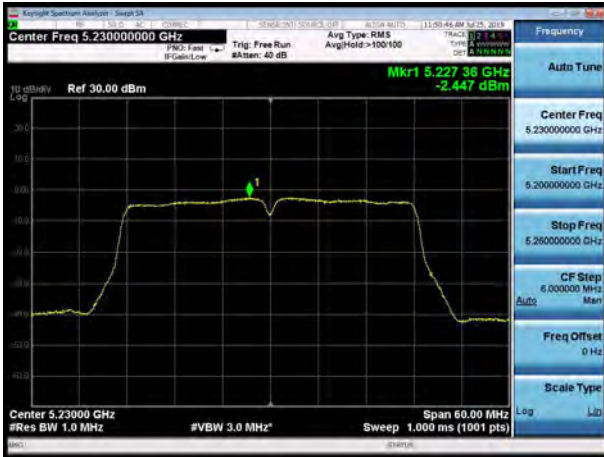

U-NII-1, 802.11ac VHT80, Channel No.: 42

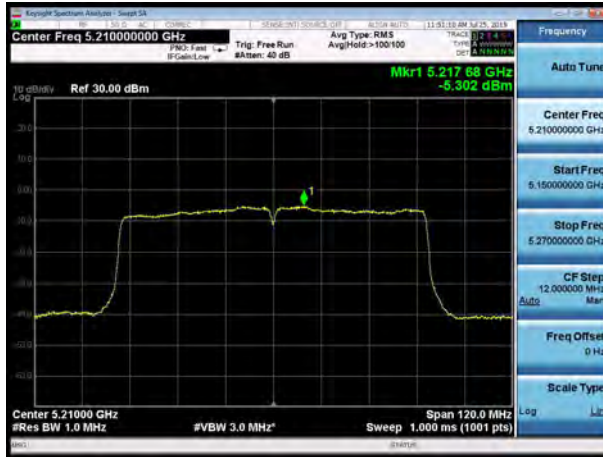

U-NII-2A, 802.11a, Channel No.: 52

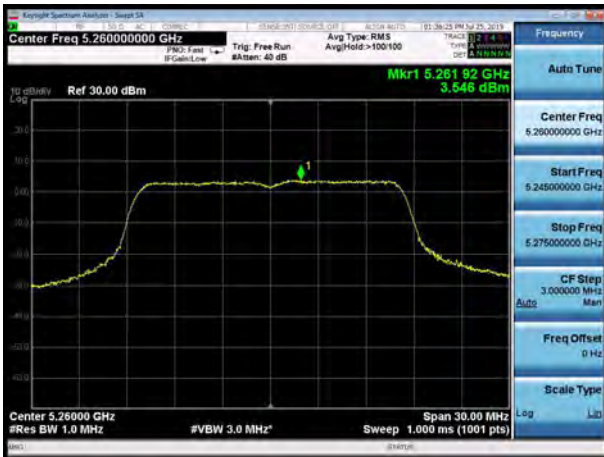

U-NII-2A, 802.11n HT20, Channel No.: 52

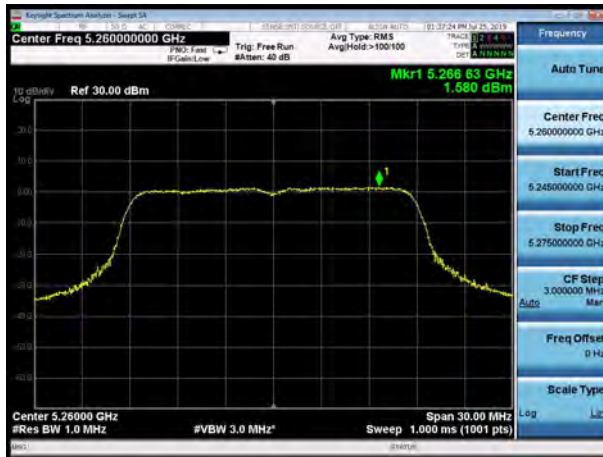

U-NII-2A, 802.11a, Channel No.: 60

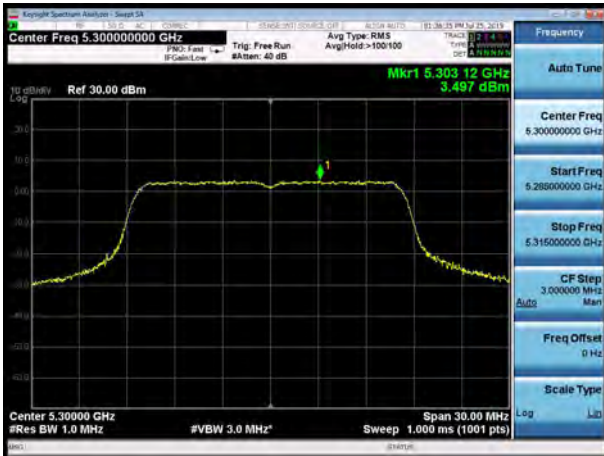

U-NII-2A, 802.11n HT20, Channel No.: 60

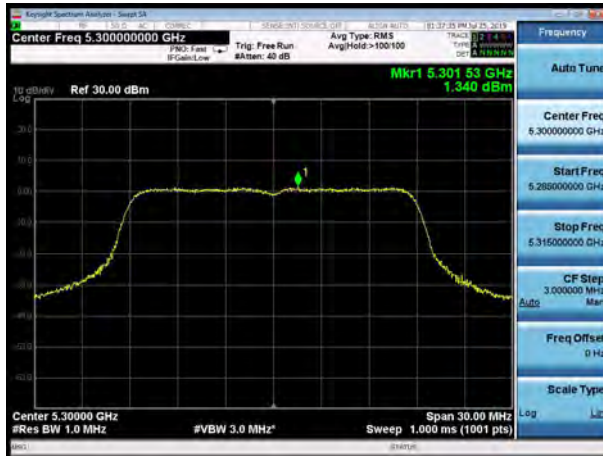



U-NII-2A, 802.11a, Channel No.: 64



U-NII-2A, 802.11n HT20, Channel No.: 64



U-NII-2A, 802.11n HT40, Channel No.: 54



U-NII-2A, 802.11ac VHT20, Channel No.: 52

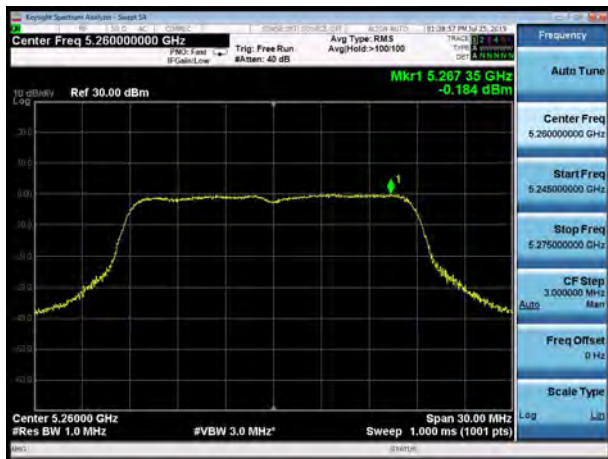

U-NII-2A, 802.11n HT40, Channel No.: 62



U-NII-2A, 802.11ac VHT20, Channel No.: 60

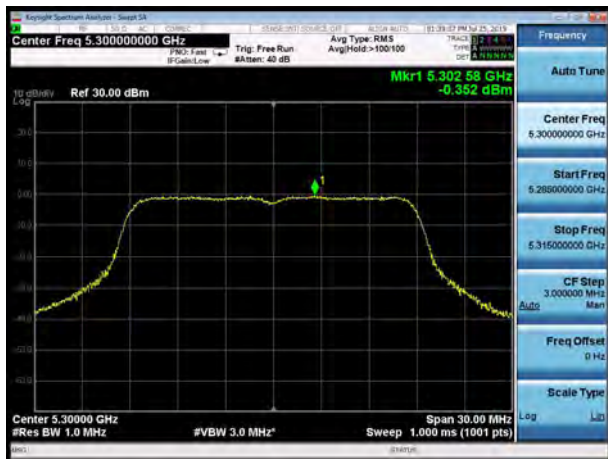



U-NII-2A, 802.11ac VHT40, Channel No.: 54



U-NII-2A, 802.11ac VHT20, Channel No.: 64



U-NII-2A, 802.11ac VHT40, Channel No.: 62

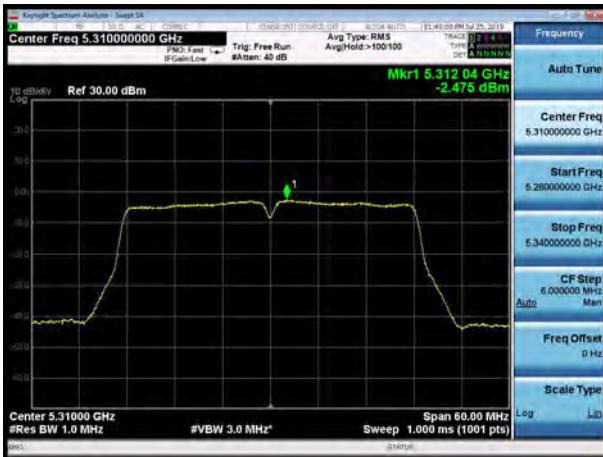

U-NII-2A, 802.11ac VHT80, Channel No.: 58



U-NII-2C, 802.11a, Channel No.: 100

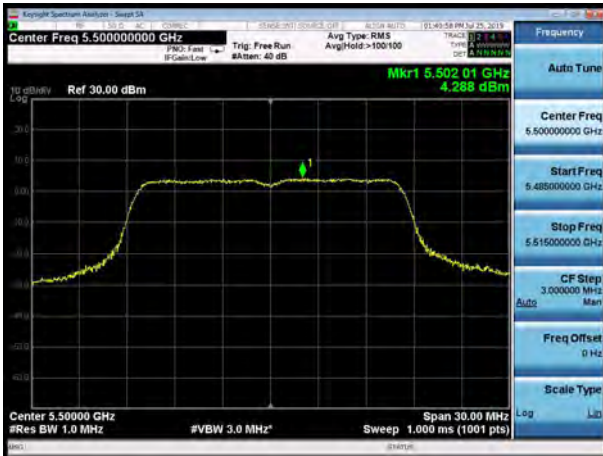

U-NII-2C, 802.11n HT20, Channel No.: 100

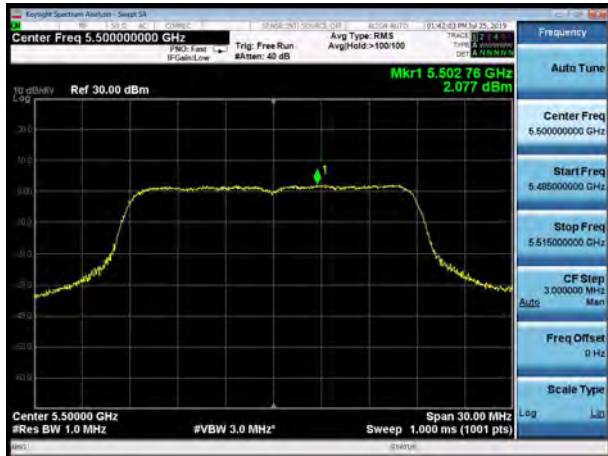



U-NII-2C, 802.11a, Channel No.: 116



U-NII-2C, 802.11n HT20, Channel No.: 116



U-NII-2C, 802.11a, Channel No.: 140



U-NII-2C, 802.11n HT20, Channel No.: 140



U-NII-2C, 802.11n HT40, Channel No.: 102



U-NII-2C, 802.11ac VHT20, Channel No.: 100





U-NII-2C, 802.11n HT40, Channel No.: 110

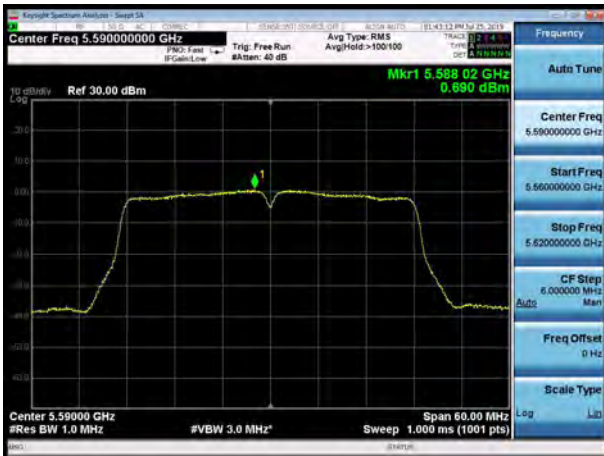

U-NII-2C, 802.11ac VHT20, Channel No.: 116

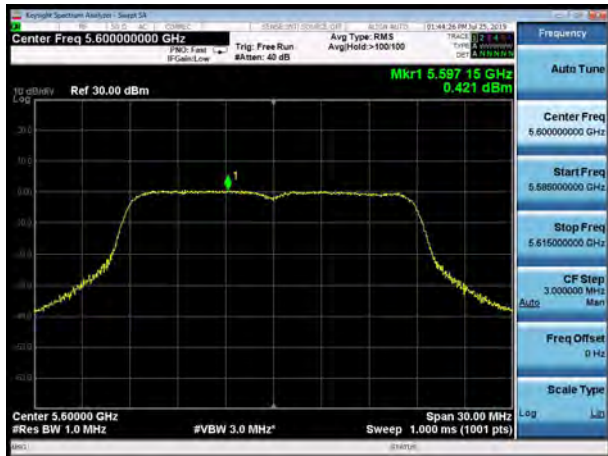

U-NII-2C, 802.11n HT40, Channel No.: 134



U-NII-2C, 802.11ac VHT20, Channel No.: 140



U-NII-2C, 802.11ac VHT40, Channel No.: 102



U-NII-2C, 802.11ac VHT80, Channel No.: 106



U-NII-2C, 802.11ac VHT40, Channel No.: 110

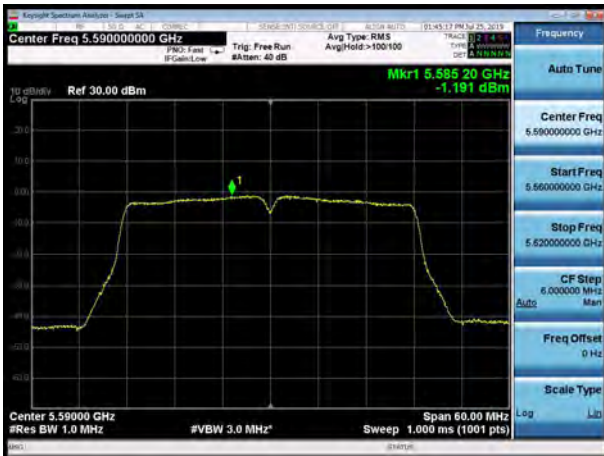

U-NII-2C, 802.11ac VHT40, Channel No.: 134

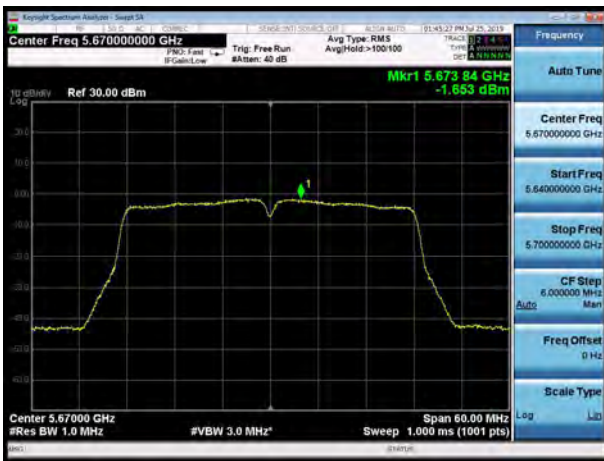



U-NII-3, 802.11a, Channel No.: 149

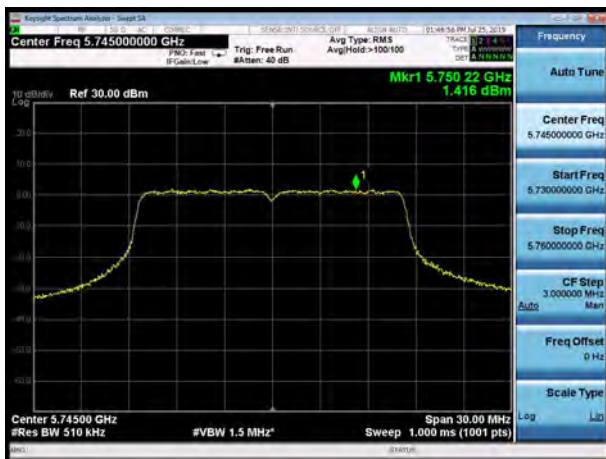

U-NII-3, 802.11n HT20, Channel No.: 149

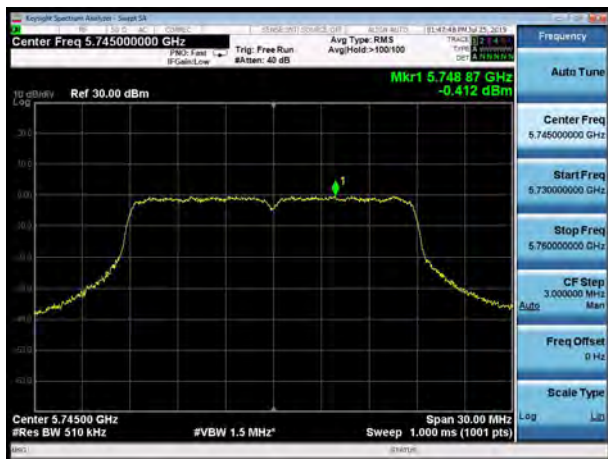

U-NII-3, 802.11a, Channel No.: 157

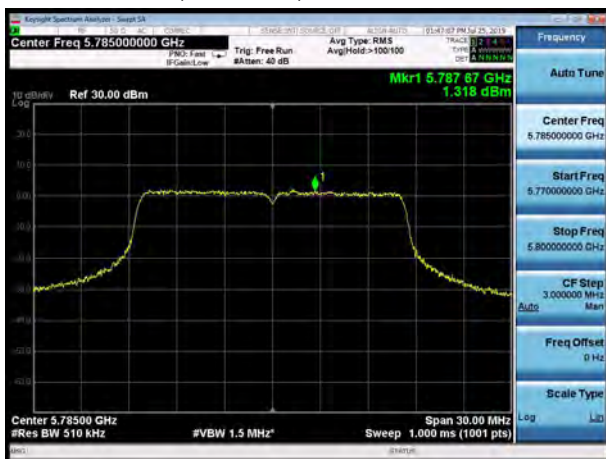

U-NII-3, 802.11n HT20, Channel No.: 157

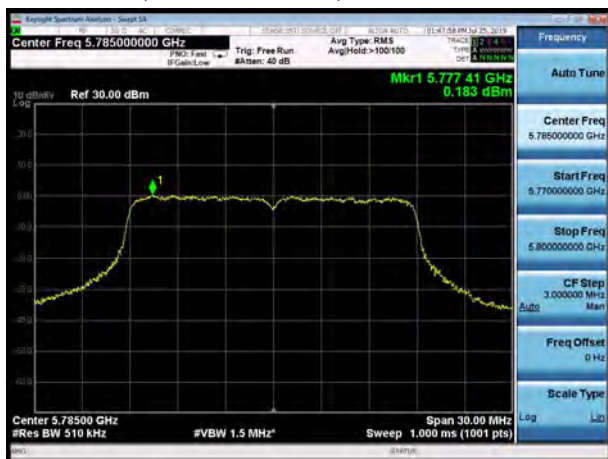

U-NII-3, 802.11a, Channel No.: 165

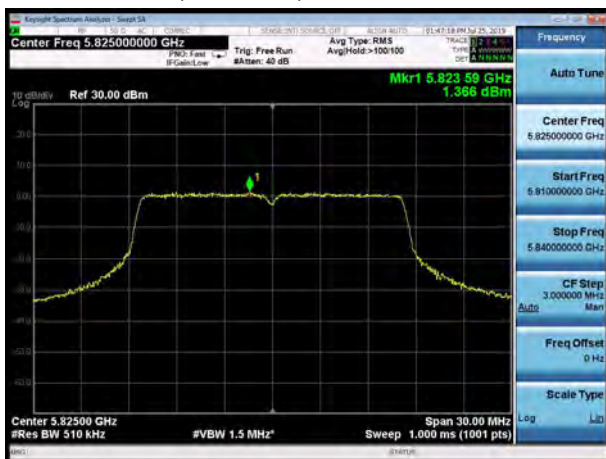

U-NII-3, 802.11n HT20, Channel No.: 165

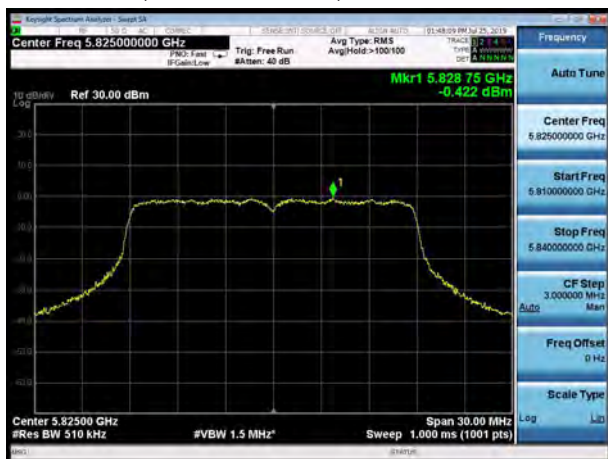



U-NII-3, 802.11n HT40, Channel No.: 151



U-NII-3, 802.11ac VHT20, Channel No.: 149

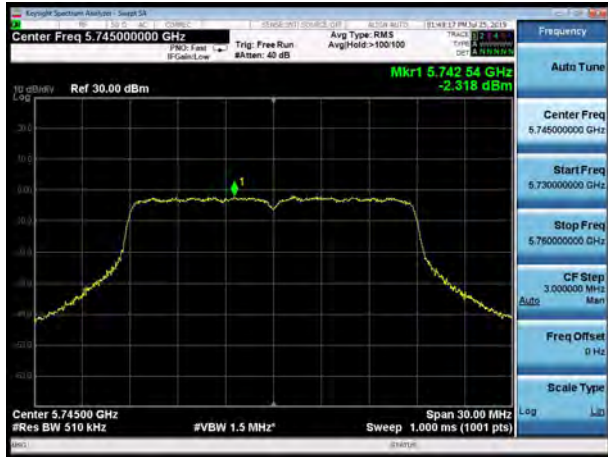

U-NII-3, 802.11n HT40, Channel No.: 159



U-NII-3, 802.11ac VHT20, Channel No.: 157



U-NII-3, 802.11ac VHT40, Channel No.: 151



U-NII-3, 802.11ac VHT20, Channel No.: 165

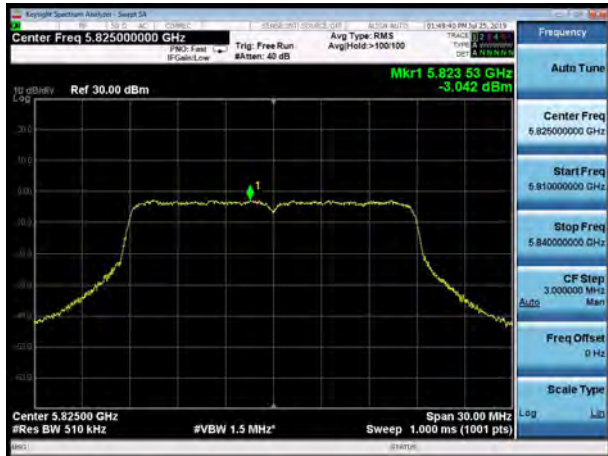



U-NII-3, 802.11ac VHT40, Channel No.: 159



U-NII-3, 802.11ac VHT80, Channel No.: 155

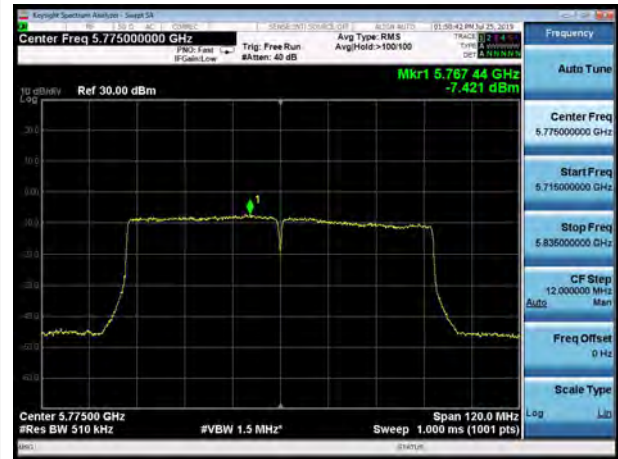



5.5. Unwanted Emission

Ambient condition

Temperature	Relative humidity	Pressure
23°C ~25°C	45%~50%	101.5kPa

Method of Measurement

The test set-up was made in accordance to the general provisions of ANSI C63.10-2013. The Equipment Under Test (EUT) was set up on a non-conductive table in the semi-anechoic chamber. The test was performed at the distance of 3 m between the EUT and the receiving antenna. The radiated emissions measurements were made in a typical installation configuration. Sweep the whole frequency band range from 9kHz to the 10th harmonic of the carrier, and the emissions less than 20 dB below the permissible value are reported.

During the test, the height of receive antenna shall be moved from 1 to 4 meters, and the antenna shall be performed under horizontal and vertical polarization. The turntable shall be rotated from 0 to 360 degrees for detecting the maximum of radiated spurious signal level. The measurements shall be repeated with orthogonal polarization of the test antenna. The data of cable loss and antenna factor has been calibrated in full testing frequency range before the testing.

Set the spectrum analyzer in the following:

Below 1GHz (detector: Peak and Quasi-Peak)

RBW=100kHz / VBW=300kHz / Sweep=AUTO

Above 1GHz (detector: Peak):

I) Peak emission levels are measured by setting the instrument as follows:

- 1) RBW = 1 MHz.
- 2) VBW \geq [3 × RBW]
- 3) Detector = peak.
- 4) Sweep time = auto.
- 5) Trace mode = max hold.
- 6) Allow sweeps to continue until the trace stabilizes. Note that if the transmission is not continuous, then the time required for the trace to stabilize will increase by a factor of approximately 1 / D, where D is the duty cycle.

II) Average emission levels are measured by setting the instrument as follows:

- a) RBW = 1 MHz.
- b) VBW \geq [3 × RBW].
- c) Detector = RMS (power averaging), if [span / (# of points in sweep)] \leq RBW / 2. Satisfying this condition can require increasing the number of points in the sweep or reducing the span. If the condition is not satisfied, then the detector mode shall be set to peak.
- d) Averaging type = power (i.e., rms) (As an alternative, the detector and averaging type may be set for linear voltage averaging. Some instruments require linear display mode to use linear voltage averaging. Log or dB averaging shall not be used.)



- e) Sweep time = auto.
- f) Perform a trace average of at least 100 traces if the transmission is continuous. If the transmission is not continuous, then the number of traces shall be increased by a factor of $1 / D$, where D is the duty cycle. For example, with 50% duty cycle, at least 200 traces shall be averaged. (If a specific emission is demonstrated to be continuous—i.e., 100% duty cycle—then rather than turning ON and OFF with the transmit cycle, at least 100 traces shall be averaged.)
- g) If tests are performed with the EUT transmitting at a duty cycle less than 98%, then a correction factor shall be added to the measurement results prior to comparing with the emission limit, to compute the emission level that would have been measured had the test been performed at 100% duty cycle. The correction factor is computed as follows:
- 1) If power averaging (rms) mode was used in the preceding step e), then the correction factor is $[10 \log (1 / D)]$, where D is the duty cycle. For example, if the transmit duty cycle was 50%, then 3 dB shall be added to the measured emission levels.
 - 2) If linear voltage averaging mode was used in the preceding step e), then the correction factor is $[20 \log (1 / D)]$, where D is the duty cycle. For example, if the transmit duty cycle was 50%, then 6 dB shall be added to the measured emission levels.
 - 3) If a specific emission is demonstrated to be continuous (100% duty cycle) rather than turning ON and OFF with the transmit cycle, then no duty cycle correction is required for that emission.

Reduce the video bandwidth until no significant variations in the displayed signal are observed in subsequent traces, provided the video bandwidth is no less than 1 Hz. For regulatory requirements that specify averaging only over the transmit duration (e.g., digital transmission system [DTS] and Unlicensed National Information Infrastructure [U-NII]), the video bandwidth shall be greater than $[1 / (\text{minimum transmitter on time})]$ and no less than 1 Hz.

The field strength of spurious emission was measured in the following position: EUT stand-up position (Z axis), lie-down position (X, Y axis). The worst emission was found in lie-down position (X axis) and the loop antenna is vertical, others antenna are vertical and horizontal.

The test is in transmitting mode.

9KHz~~~30MHz

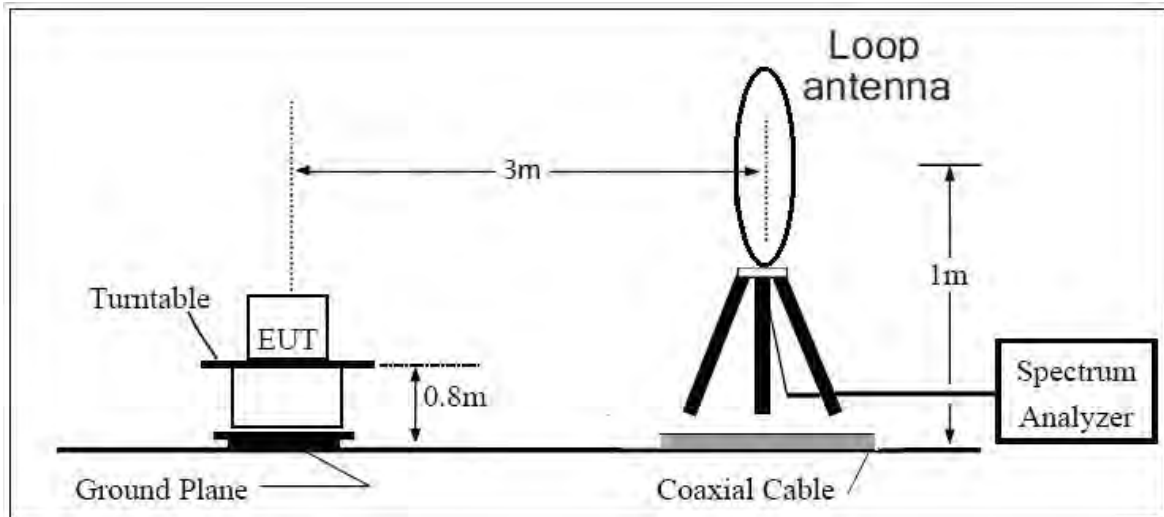

30MHz~~~ 1GHz

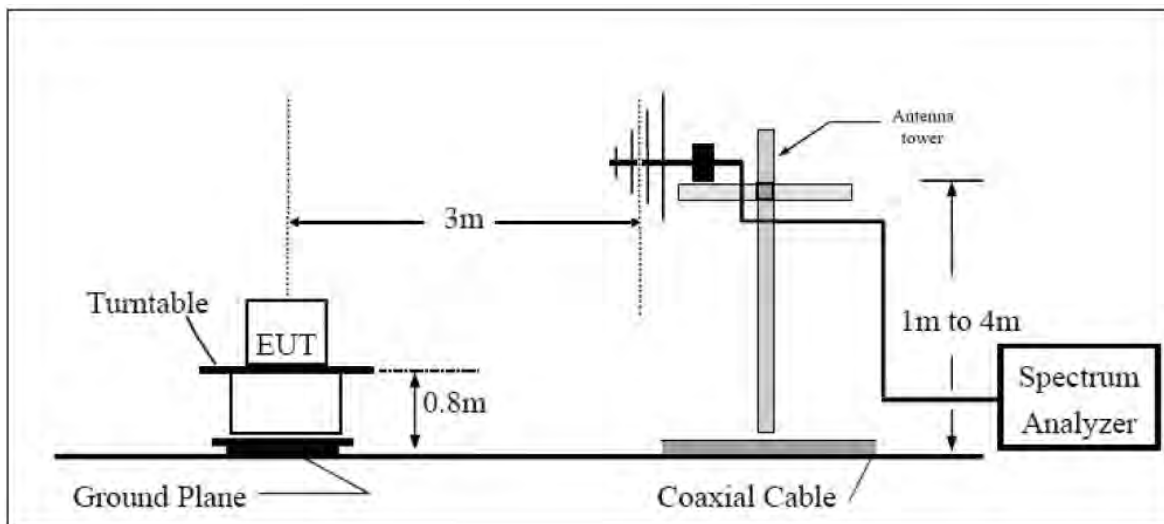

Above 1GHz

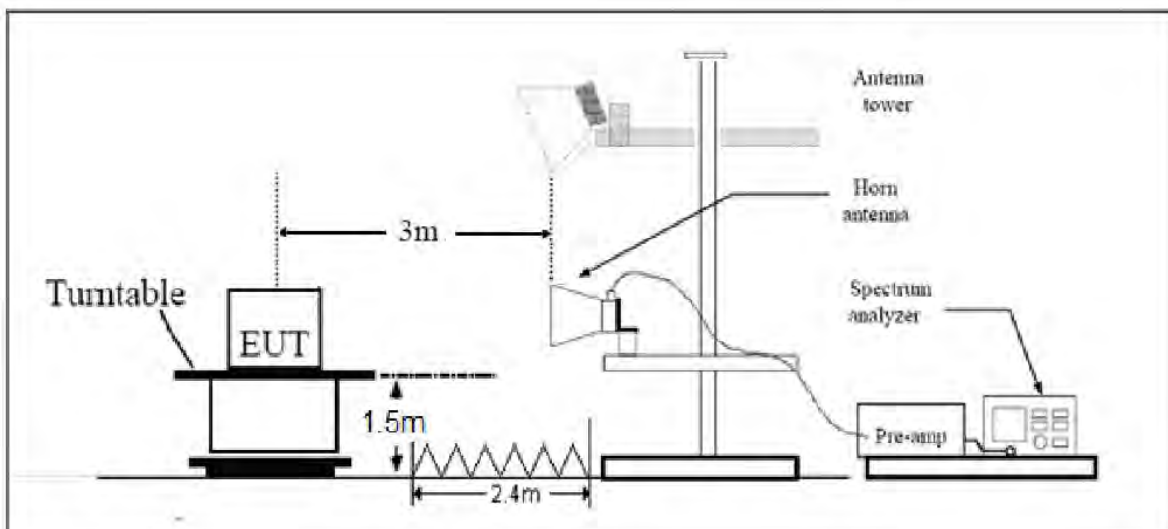

Note: Area side:2.4mX3.6m

**Limits**

- (1) For transmitters operating in the 5725-5850 MHz band: All emissions shall be limited to a level of -27 dBm/MHz at 75 MHz or more above or below the band edge increasing linearly to 10 dBm/MHz at 25 MHz above or below the band edge, and from 25 MHz above or below the band edge increasing linearly to a level of 15.6 dBm/MHz at 5 MHz above or below the band edge, and from 5 MHz above or below the band edge increasing linearly to a level of 27 dBm/MHz at the band edge.
- (2) For transmitters operating in the 5.15-5.25 GHz band: All emissions outside of the 5.15-5.35 GHz band shall not exceed an e.i.r.p. of -27 dBm/MHz(68.2dBμV/m).
- (3) For transmitters operating in the 5.25-5.35 GHz band: All emissions outside of the 5.15-5.35 GHz band shall not exceed an e.i.r.p. of -27 dBm/MHz(68.2dBμV/m).
- (4) For transmitters operating in the 5.47-5.725 GHz band: All emissions outside of the 5.47-5.725 GHz band shall not exceed an e.i.r.p. of -27 dBm/MHz(68.2dBμV/m).

Note: the following formula is used to convert the EIRP to field strength

§1、 $E[\text{dB}\mu\text{V}/\text{m}] = \text{EIRP}[\text{dBm}] - 20 \log(d[\text{meters}]) + 104.77$, where E = field strength and

d = distance at which field strength limit is specified in the rules;

§2、 $E[\text{dB}\mu\text{V}/\text{m}] = \text{EIRP}[\text{dBm}] + 95.2$, for d = 3 meters

- (5) Unwanted spurious emissions fallen in restricted bands per FCC Part15.205 shall comply with the general field strength limits set forth in § 15.209 as below table.

Frequency of emission (MHz)	Field strength(uV/m)	Field strength(dBuV/m)
0.009–0.490	2400/F(kHz)	/
0.490–1.705	24000/F(kHz)	/
1.705–30.0	30	/
30-88	100	40
88-216	150	43.5
216-960	200	46
Above960	500	54



MHz	MHz	MHz	GHz
0.090 - 0.110	16.42 - 16.423	399.9 - 410	4.5 - 5.15
0.495 - 0.505	16.69475 - 16.69525	608 - 614	5.35 - 5.46
2.1735 - 2.1905	16.80425 - 16.80475	960 - 1240	7.25 - 7.75
4.125 - 4.128	25.5 - 25.67	1300 - 1427	8.025 - 8.5
4.17725 - 4.17775	37.5 - 38.25	1435 - 1626.5	9.0 - 9.2
4.20725 - 4.20775	73 - 74.6	1645.5 - 1646.5	9.3 - 9.5
6.215 - 6.218	74.8 - 75.2	1660 - 1710	10.6 - 12.7
6.26775 - 6.26825	108 - 121.94	1718.8 - 1722.2	13.25 - 13.4
6.31175 - 6.31225	123 - 138	2200 - 2300	14.47 - 14.5
8.291 - 8.294	149.9 - 150.05	2310 - 2390	15.35 - 16.2
8.362 - 8.366	156.52475 - 156.52525	2483.5 - 2500	17.7 - 21.4
8.37625 - 8.38675	156.7 - 156.9	2690 - 2900	22.01 - 23.12
8.41425 - 8.41475	162.0125 - 167.17	3260 - 3267	23.6 - 24.0
12.29 - 12.293	167.72 - 173.2	3332 - 3339	31.2 - 31.8
12.51975 - 12.52025	240 - 285	3345.8 - 3358	36.43 - 36.5
12.57675 - 12.57725	322 - 335.4	3600 - 4400	(²)
13.36 - 13.41			

Measurement Uncertainty

The assessed measurement uncertainty to ensure 95% confidence level for the normal distribution is with the coverage factor $k = 1.96$.

Frequency	Uncertainty
9KHz-30MHz	3.55 dB
30MHz-200MHz	4.02 dB
200MHz-1GHz	3.28 dB
1GHz-18G	3.70 dB
18GHz-26.5GHz	5.78 dB
26.5G-40GHz	5.82 dB



Test Results:

The modulation and bandwidth are similar for 802.11n mode for 20MHz/40MHz and 802.11ac mode for V20MHz/V40MHz, therefore investigated worst case to representative mode in test report.

The signal beyond the limit is carrier.

U-NII-1

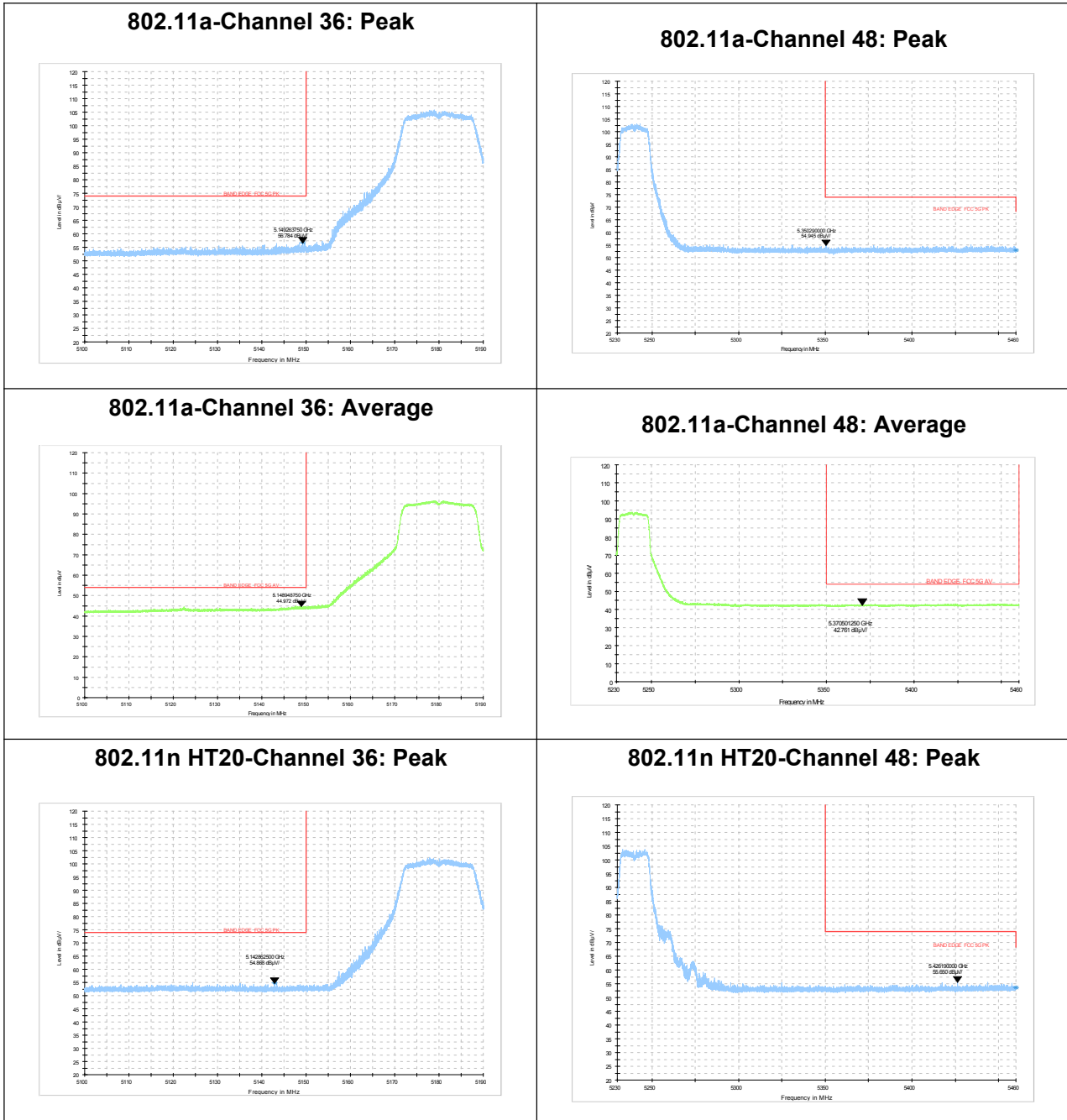



802.11n HT20-Channel 36: Average

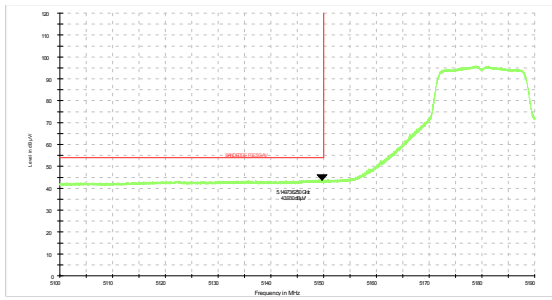

802.11n HT20-Channel 48: Average

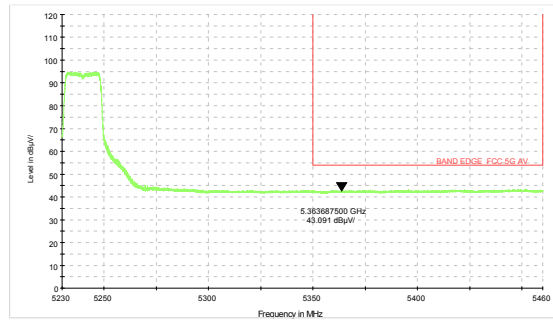

802.11n HT40-Channel 38: Peak

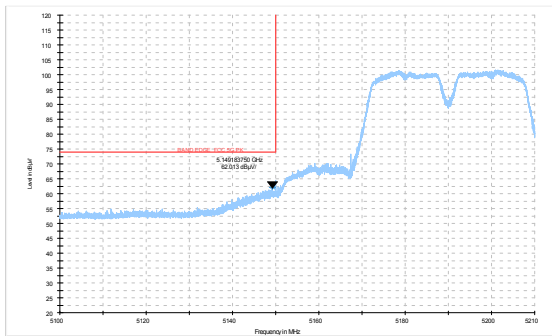

802.11n HT40-Channel 46: Peak

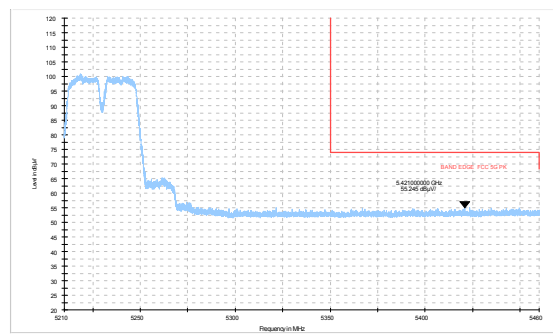

802.11n HT40-Channel 38: Average

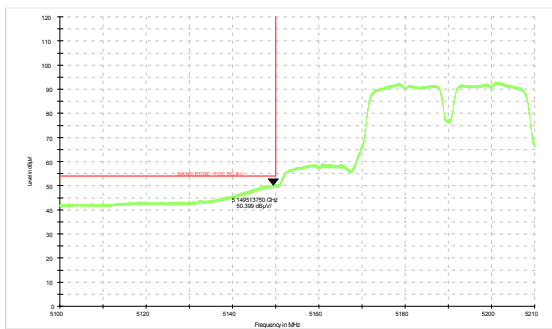

802.11n HT40-Channel 46: Average

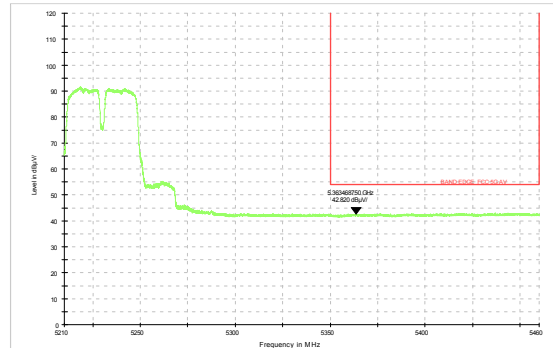

802.11ac VHT80 -Channel 42: Peak

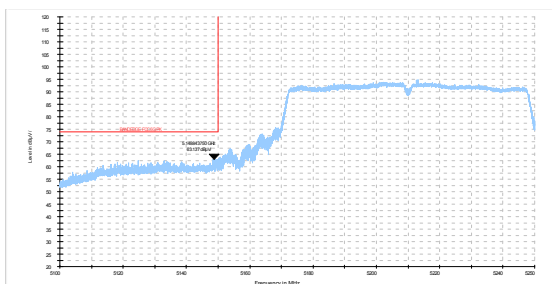

802.11ac VHT80- Channel 42: Average

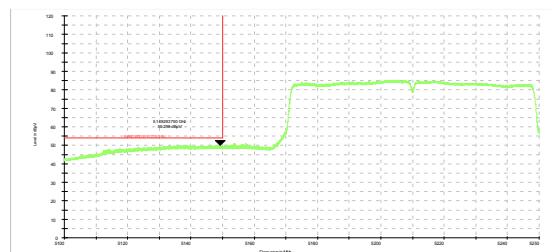



U-NII-2A

802.11a-Channel 52: Peak

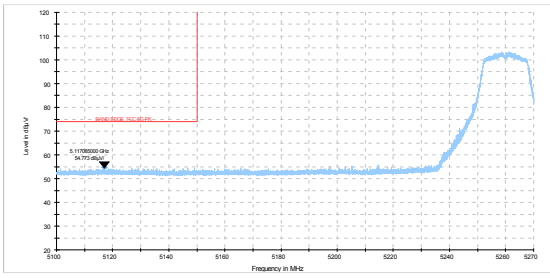

802.11a-Channel 64: Peak

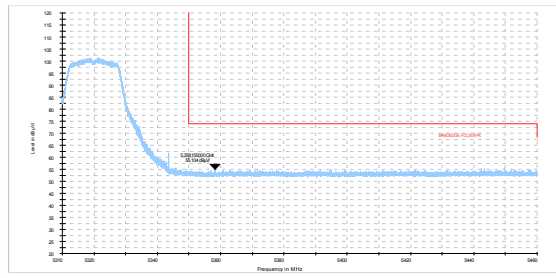

802.11a-Channel 52: Average

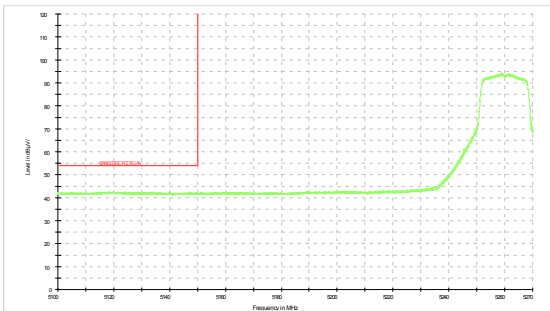

802.11a-Channel 64: Average

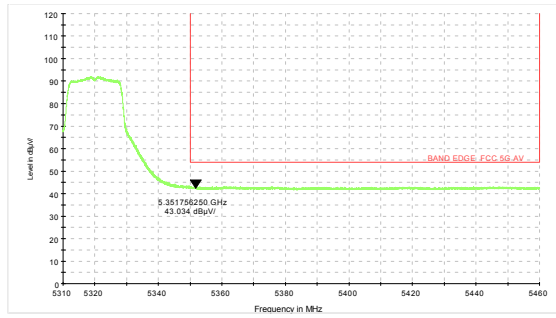

802.11n HT20-Channel 52: Peak

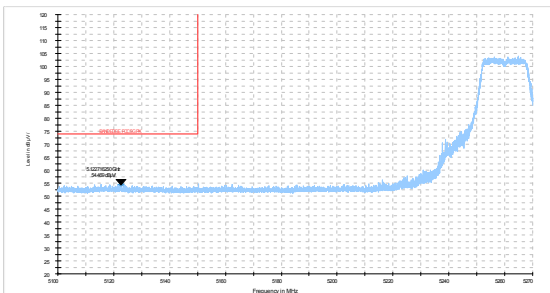

802.11n HT20-Channel 64: Peak

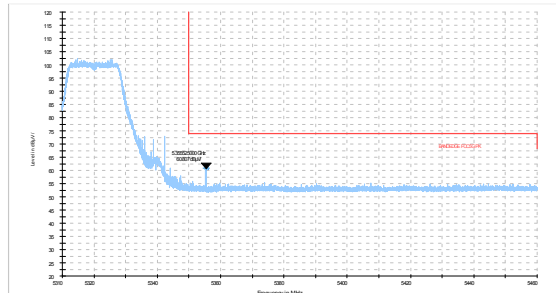

802.11n HT20-Channel 52: Average

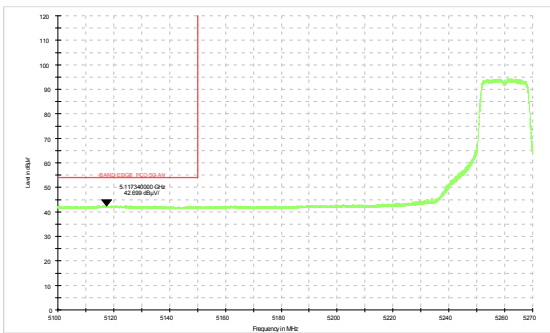

802.11n HT20-Channel 64: Average

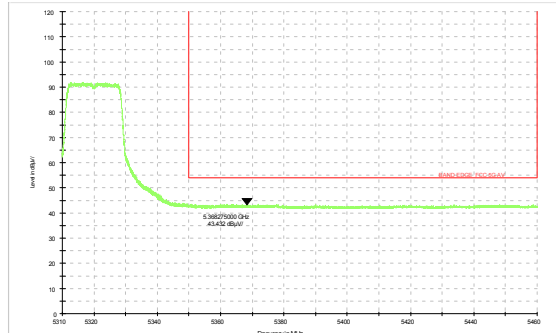



802.11n HT40-Channel 54: Peak

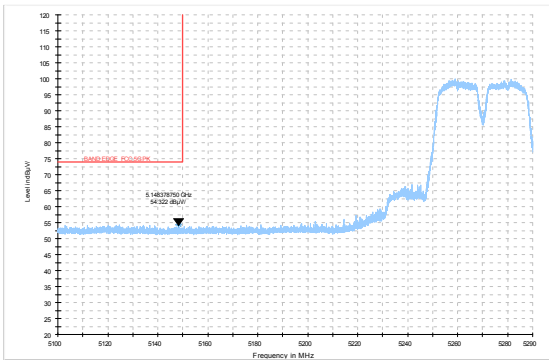

802.11n HT40-Channel 62: Peak

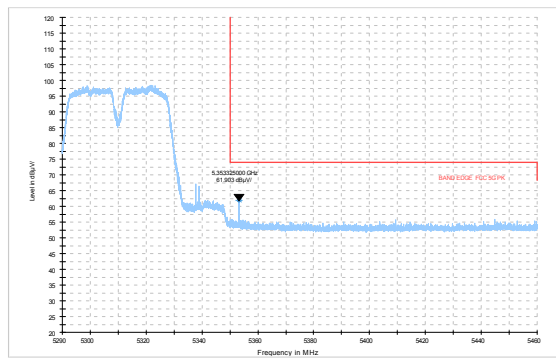

802.11n HT40-Channel 54: Average

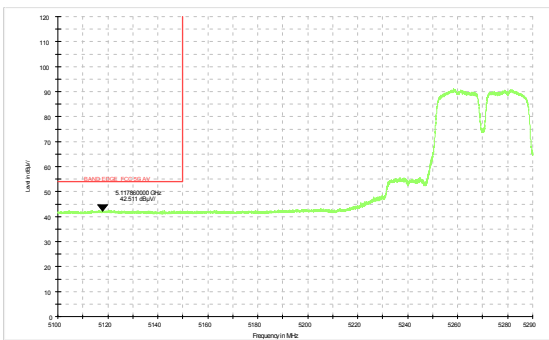

802.11n HT40-Channel 62: Average

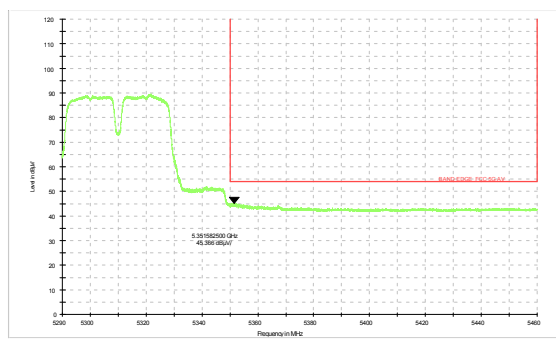

802.11ac VHT80 -Channel 58: Peak

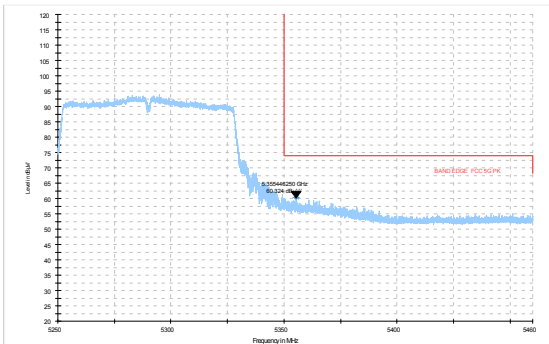

802.11ac VHT80- Channel 58: Average

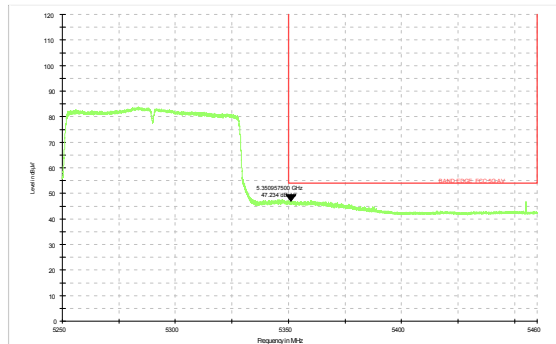



U-NII-2C

802.11a-Channel 100: Peak

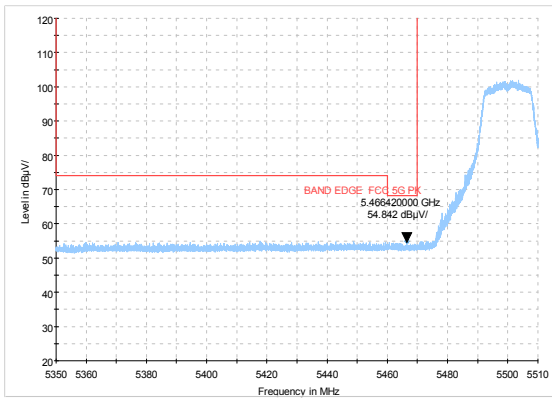

802.11n HT20-Channel 100: Peak

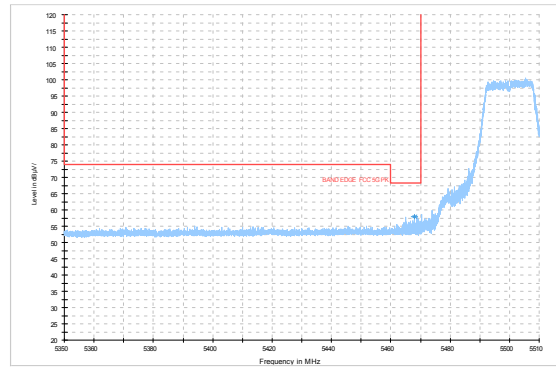

802.11a-Channel 100: Average

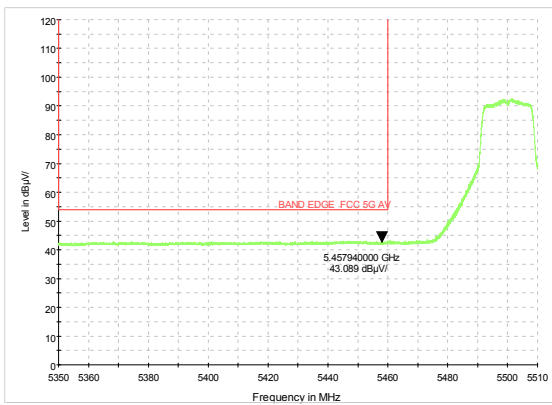

802.11n HT20-Channel 100: Average

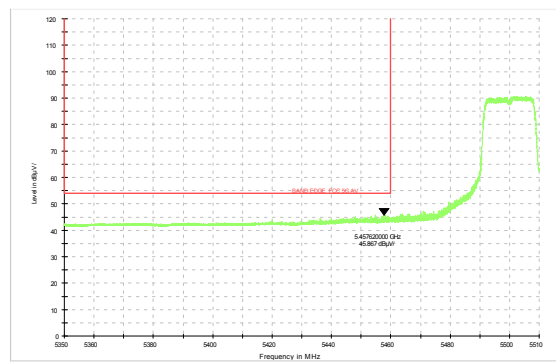

802.11a-Channel 140: Peak

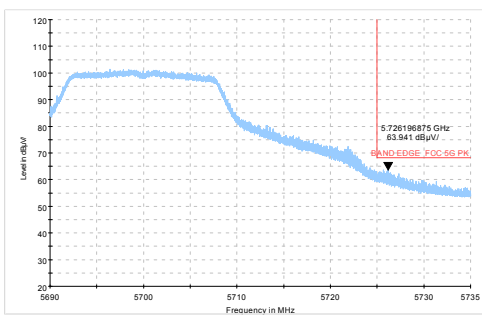

802.11n HT20-Channel 140: Peak

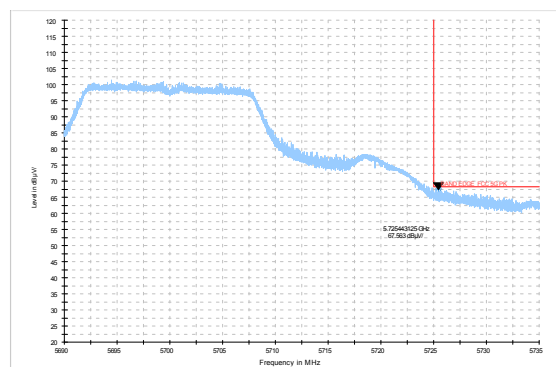



802.11n HT40-Channel 102: Peak

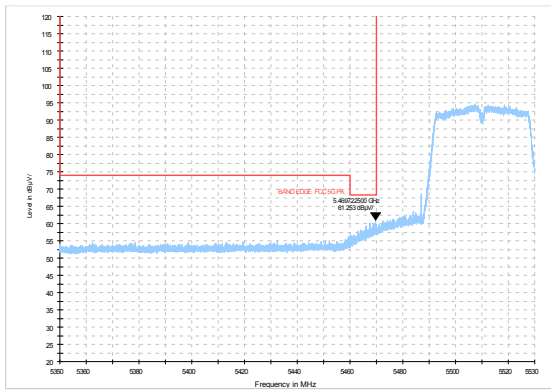

802.11ac VHT80 -Channel 106: Peak

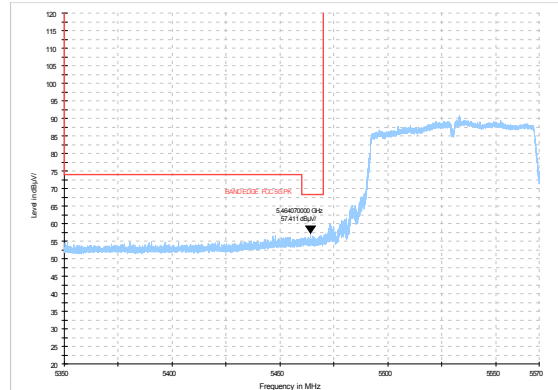

802.11n HT40-Channel 102: Average

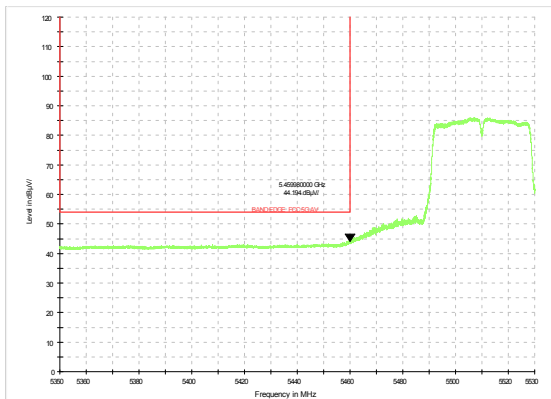

802.11ac VHT80- Channel 106: Average

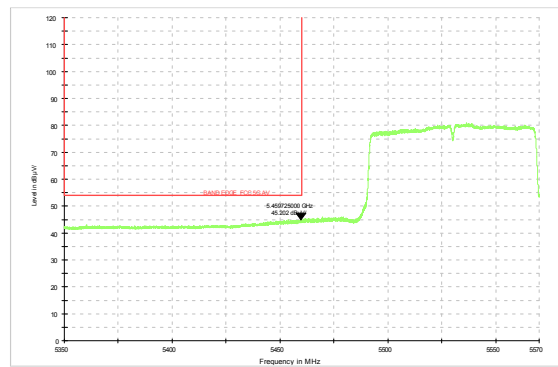

802.11n HT40-Channel 134: Peak

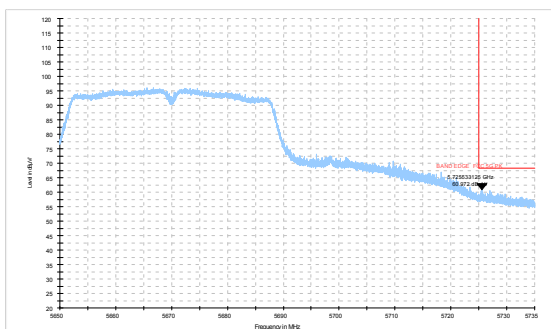



U-NII-3

802.11a-Channel 149: Peak

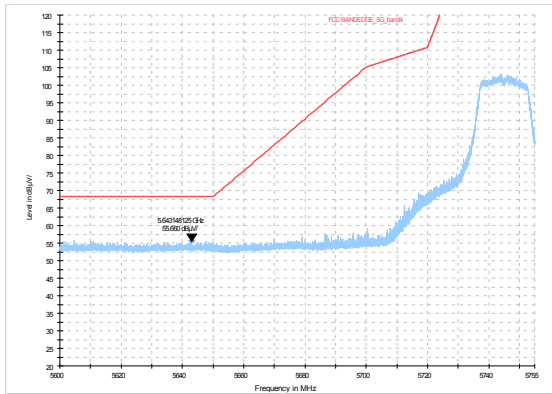

802.11a-Channel 165: Peak

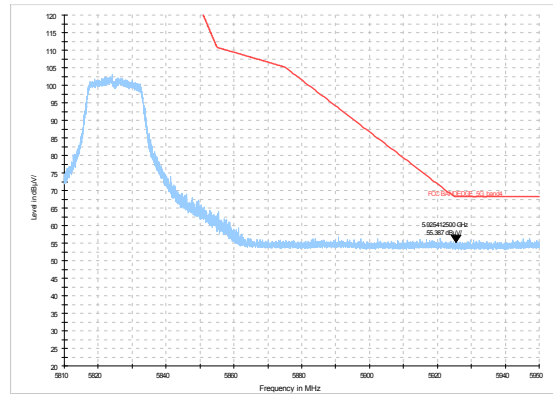

802.11n HT20-Channel 149: Peak

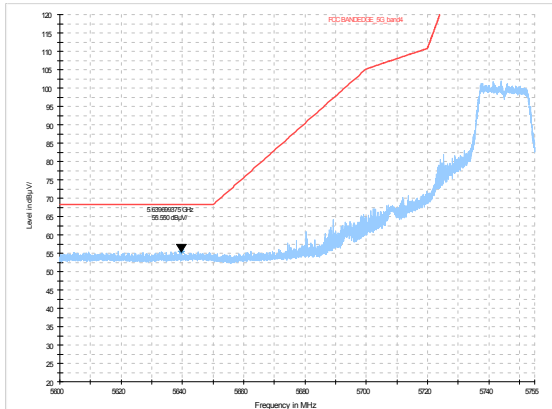

802.11n HT20-Channel 165: Peak

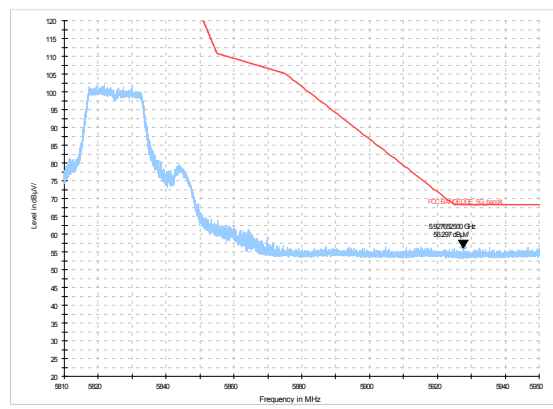

802.11n HT40-Channel 151: Peak

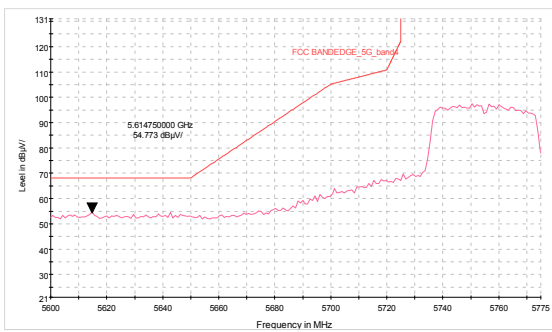

802.11n HT40-Channel 159: Peak

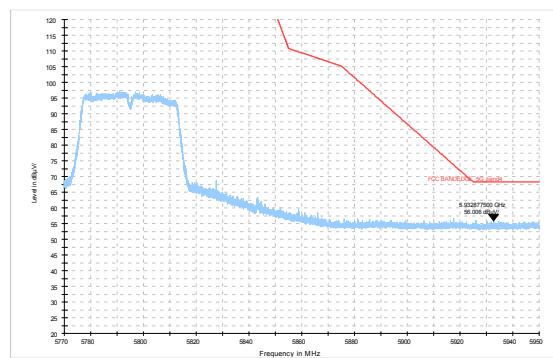

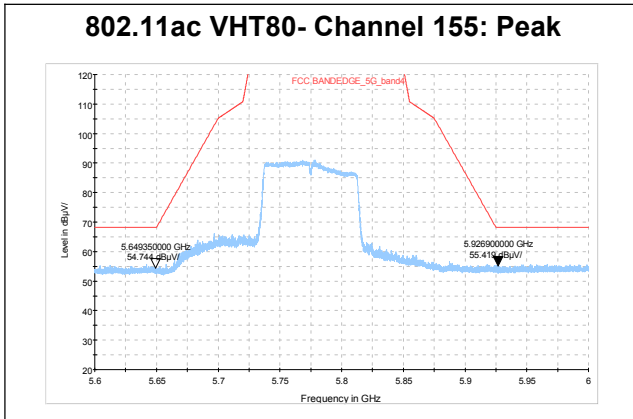

**Result of RE****Test result**

Sweep the whole frequency band through the range from 9kHz to the 10th harmonic of the carrier, the Emissions in the frequency band 9kHz-30MHz and 26.5GHz-40GHz are more than 20dB below the limit are not reported.

During the test, the Radiates Emission from 30MHz to 1GHz was performed in all modes with all channels, 802.11ac (HT80) CH106 are selected as the worst condition. The test data of the worst-case condition was recorded in this report.

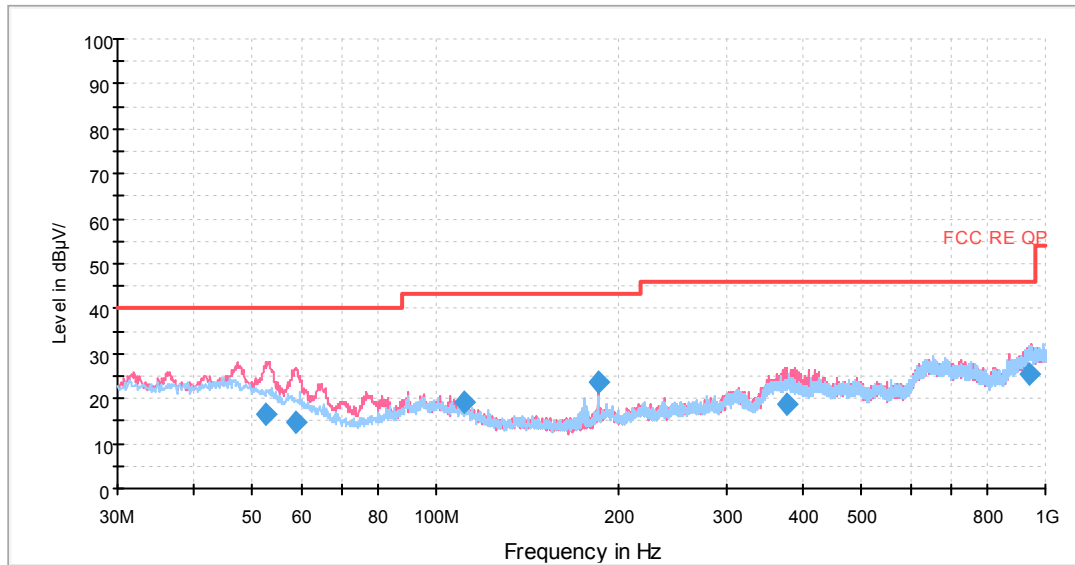
Continuous TX mode:

Radiates Emission from 30MHz to 1GHz

Frequency (MHz)	Quasi-Peak (dBuV/m)	Height (cm)	Polarization	Azimuth (deg)	Correct Factor (dB)	Margin (dB)	Limit (dBuV/m)
52.683881	16.4	120.0	V	134.0	-6.4	23.6	40.0
58.871303	14.9	120.0	V	300.0	-8.3	25.1	40.0
111.602247	19.2	125.0	V	50.0	-11.7	24.3	43.5
184.249425	23.7	120.0	V	300.0	-13.0	19.8	43.5
376.303500	18.9	100.0	V	69.0	-5.5	27.1	46.0
944.725500	25.4	195.0	V	326.0	2.0	20.6	46.0

Remark: 1. Correction Factor = Antenna factor+ Insertion loss(cable loss+amplifier gain)

2. Margin = Limit – Quasi-Peak



802.11a CH36

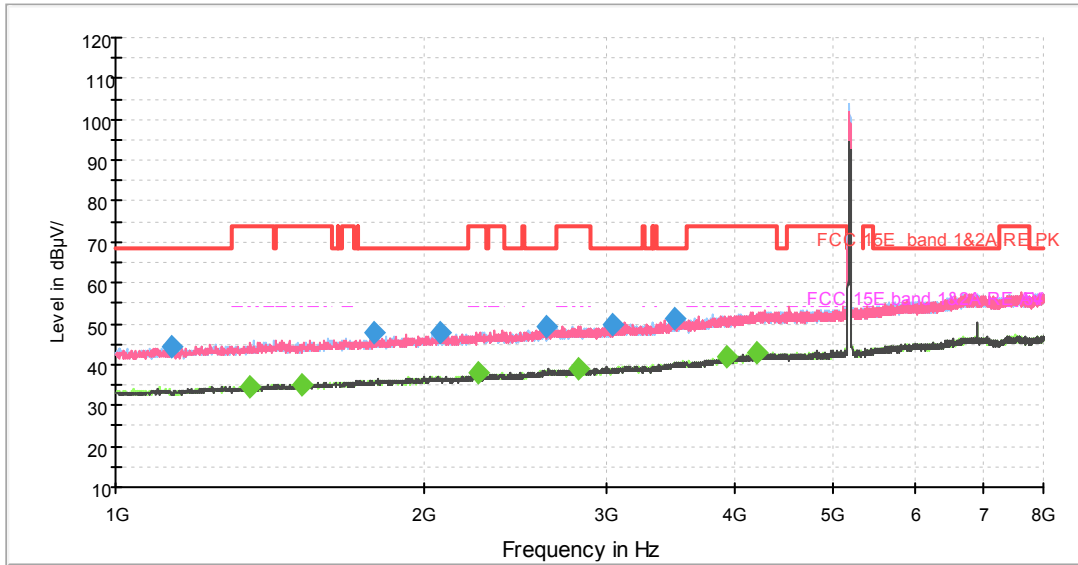

Note: The signal beyond the limit is carrier.
Radiates Emission from 1GHz to 8GHz

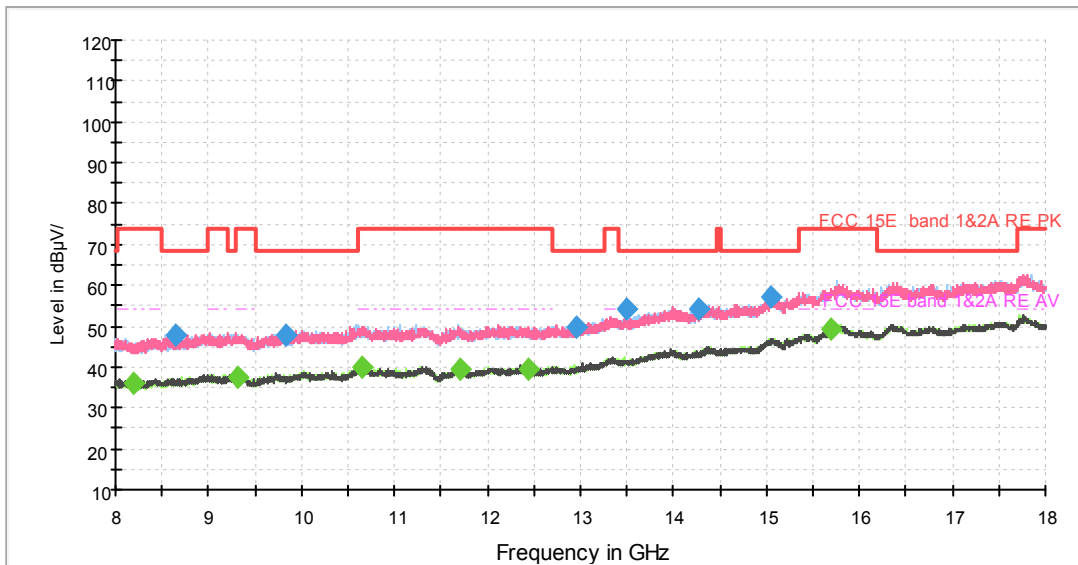

Radiates Emission from 8GHz to 18GHz

Frequency (MHz)	Peak (dBuV/m)	Height (cm)	Polarization	Azimuth (deg)	Correct Factor (dB)	Margin (dB)	Limit (dBuV/m)
1133.000000	44.2	200.0	H	256.0	0.3	24.0	68.2
1783.125000	47.6	200.0	H	0.0	3.4	20.6	68.2
2065.750000	47.6	100.0	V	5.0	4.4	20.6	68.2
2625.750000	49.5	100.0	H	324.0	6.8	18.7	68.2
3047.500000	49.6	100.0	V	92.0	8.4	18.6	68.2



3500.750000	51.2	100.0	H	225.0	9.9	17.0	68.2
-------------	------	-------	---	-------	-----	------	------

Remark: 1. Correction Factor = Antenna factor+ Insertion loss (cable loss + amplifier gain)

Frequency (MHz)	Average (dBuV/m)	Height (cm)	Polarization	Azimuth (deg)	Correct Factor (dB)	Margin (dB)	Limit (dBuV/m)
1348.250000	34.4	100.0	H	341.0	1.5	19.6	54.0
1516.250000	35.0	200.0	H	197.0	2.2	19.0	54.0
2251.250000	37.8	100.0	H	250.0	5.2	16.2	54.0
2820.875000	38.7	100.0	H	79.0	7.5	15.3	54.0
3926.875000	41.7	200.0	H	247.0	11.3	12.3	54.0
4216.500000	42.8	200.0	V	236.0	12.2	11.2	54.0

Remark: 1. Correction Factor = Antenna factor+ Insertion loss (cable loss + amplifier gain)



802.11a CH40

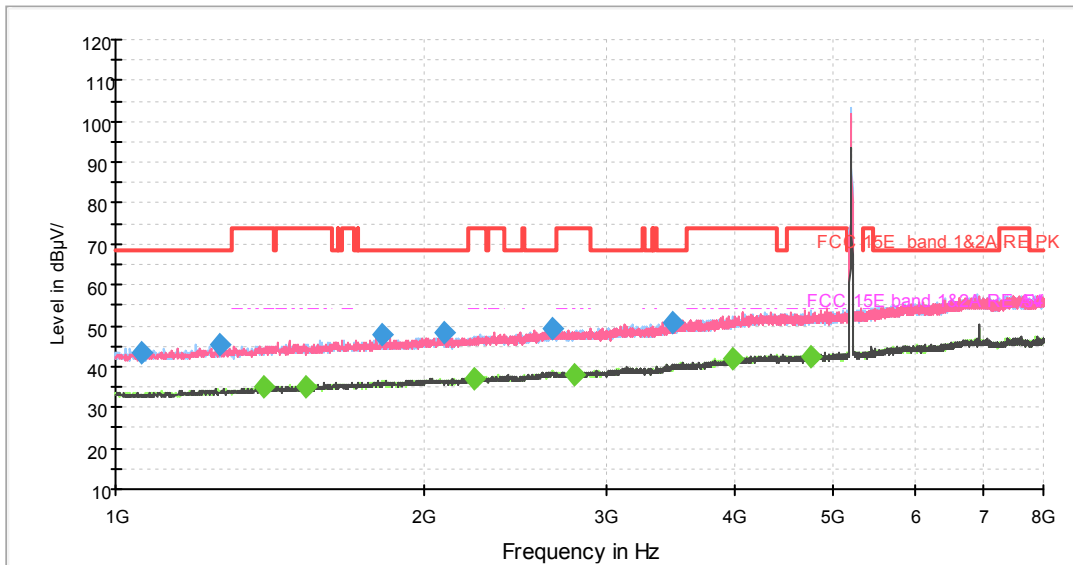

Note: The signal beyond the limit is carrier.
Radiates Emission from 1GHz to 8GHz

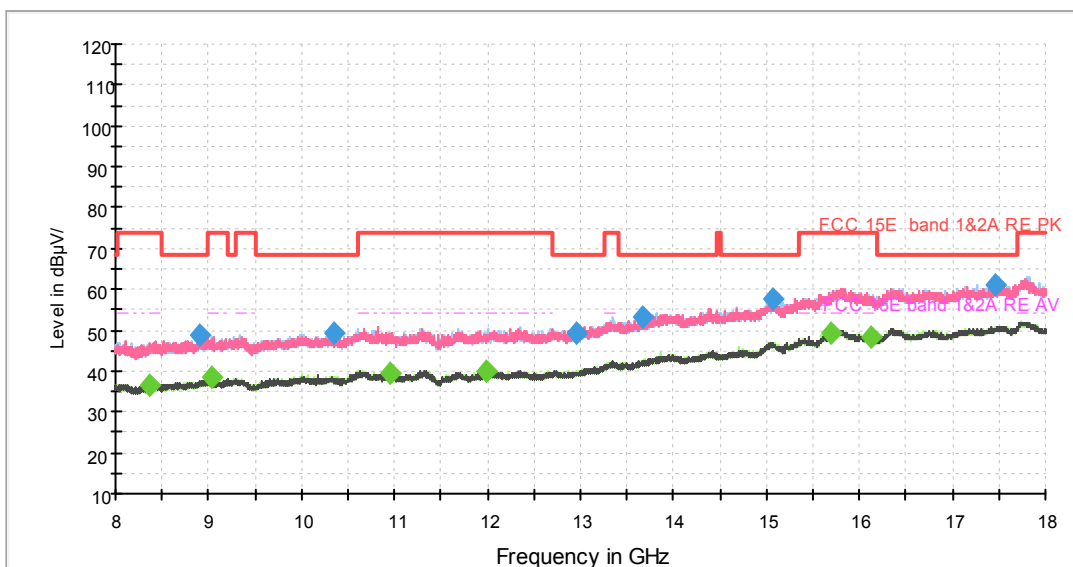

Radiates Emission from 8GHz to 18GHz

Frequency (MHz)	Peak (dBuV/m)	Height (cm)	Polarization	Azimuth (deg)	Correct Factor (dB)	Margin (dB)	Limit (dBuV/m)
1059.500000	43.4	200.0	H	114.0	-0.3	24.8	68.2
1261.625000	45.3	200.0	V	0.0	1.0	22.9	68.2
1819.875000	47.6	100.0	H	217.0	3.5	20.6	68.2
2086.750000	48.5	200.0	V	231.0	4.4	19.7	68.2
2664.250000	49.5	200.0	V	294.0	6.9	18.7	68.2



3481.500000	50.6	100.0	V	0.0	9.8	17.6	68.2
-------------	------	-------	---	-----	-----	------	------

Remark: 1. Correction Factor = Antenna factor+ Insertion loss (cable loss + amplifier gain)

Frequency (MHz)	Average (dBuV/m)	Height (cm)	Polarization	Azimuth (deg)	Correct Factor (dB)	Margin (dB)	Limit (dBuV/m)
1392.000000	35.1	100.0	V	29.0	1.8	18.9	54.0
1535.500000	34.9	200.0	V	190.0	2.2	19.1	54.0
2234.625000	37.0	100.0	H	101.0	5.1	17.0	54.0
2792.000000	38.1	200.0	H	0.0	7.4	15.9	54.0
3983.750000	41.7	200.0	H	188.0	11.5	12.3	54.0
4751.125000	42.3	100.0	H	283.0	13.2	11.7	54.0

Remark: 1. Correction Factor = Antenna factor+ Insertion loss (cable loss + amplifier gain)



802.11a CH48

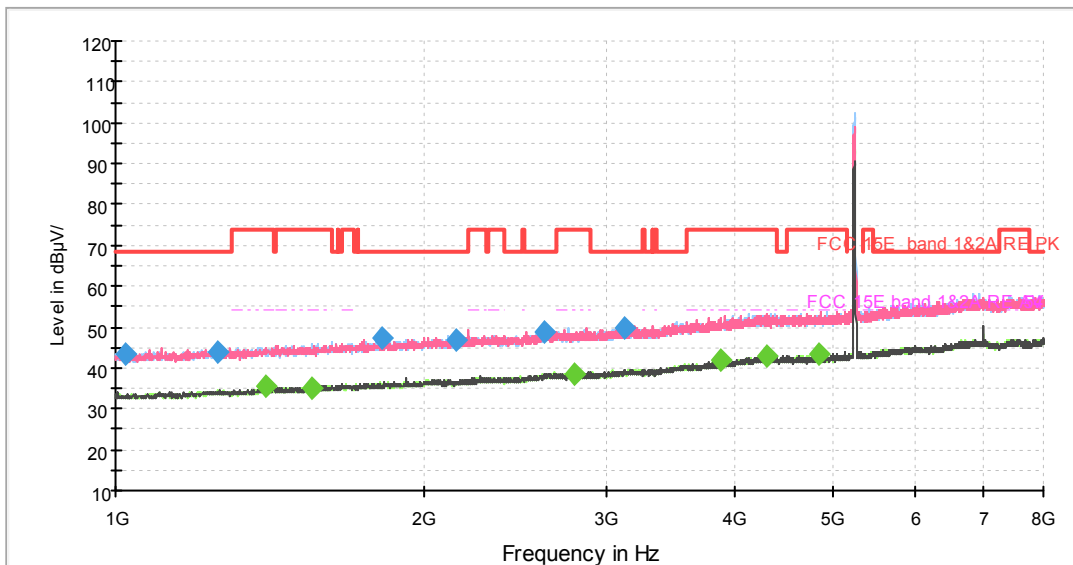

Note: The signal beyond the limit is carrier.
Radiates Emission from 1GHz to 8GHz

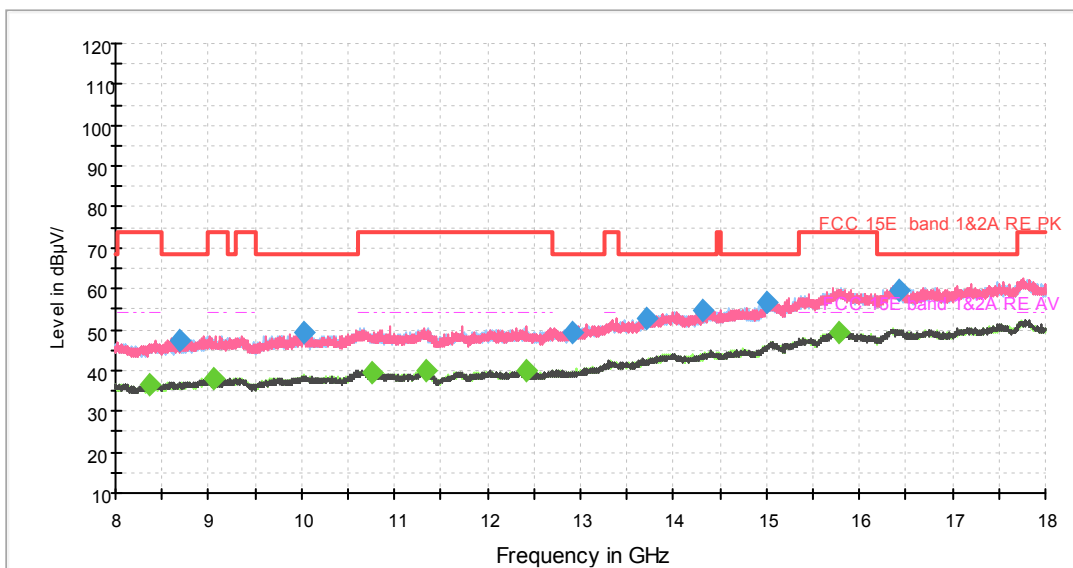

Radiates Emission from 8GHz to 18GHz

Frequency (MHz)	Peak (dBuV/m)	Height (cm)	Polarization	Azimuth (deg)	Correct Factor (dB)	Margin (dB)	Limit (dBuV/m)
1021.875000	43.3	100.0	V	0.0	-0.5	24.9	68.2
1254.625000	43.9	200.0	H	150.0	1.0	24.3	68.2
1820.750000	47.1	200.0	V	309.0	3.5	21.1	68.2
2148.000000	46.8	200.0	H	150.0	4.7	21.4	68.2
2616.125000	48.9	100.0	V	201.0	6.7	19.3	68.2



3129.750000	49.9	100.0	V	37.0	8.7	18.3	68.2
-------------	------	-------	---	------	-----	------	------

Remark: 1. Correction Factor = Antenna factor+ Insertion loss (cable loss + amplifier gain)

Frequency (MHz)	Average (dBuV/m)	Height (cm)	Polarization	Azimuth (deg)	Correct Factor (dB)	Margin (dB)	Limit (dBuV/m)
1401.625000	35.3	100.0	H	353.0	1.9	18.7	54.0
1553.000000	34.9	100.0	H	254.0	2.3	19.1	54.0
2800.750000	38.7	100.0	H	189.0	7.4	15.3	54.0
3881.375000	41.9	100.0	H	279.0	11.1	12.1	54.0
4304.875000	43.0	100.0	H	197.0	12.4	11.0	54.0
4833.375000	43.4	100.0	V	162.0	13.4	10.6	54.0

Remark: 1. Correction Factor = Antenna factor+ Insertion loss (cable loss + amplifier gain)



802.11a CH52

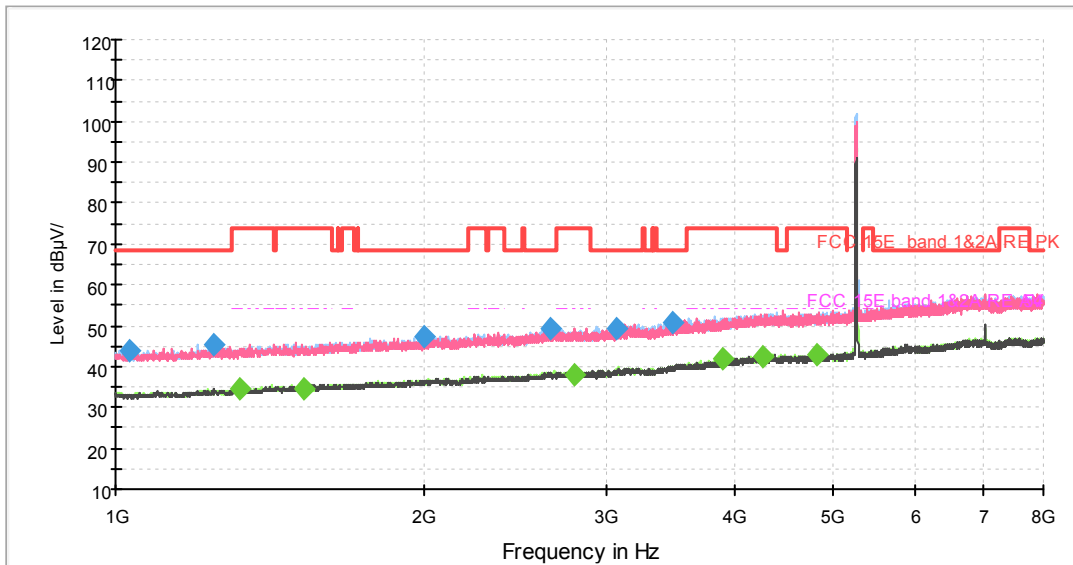

Note: The signal beyond the limit is carrier.
Radiates Emission from 1GHz to 8GHz

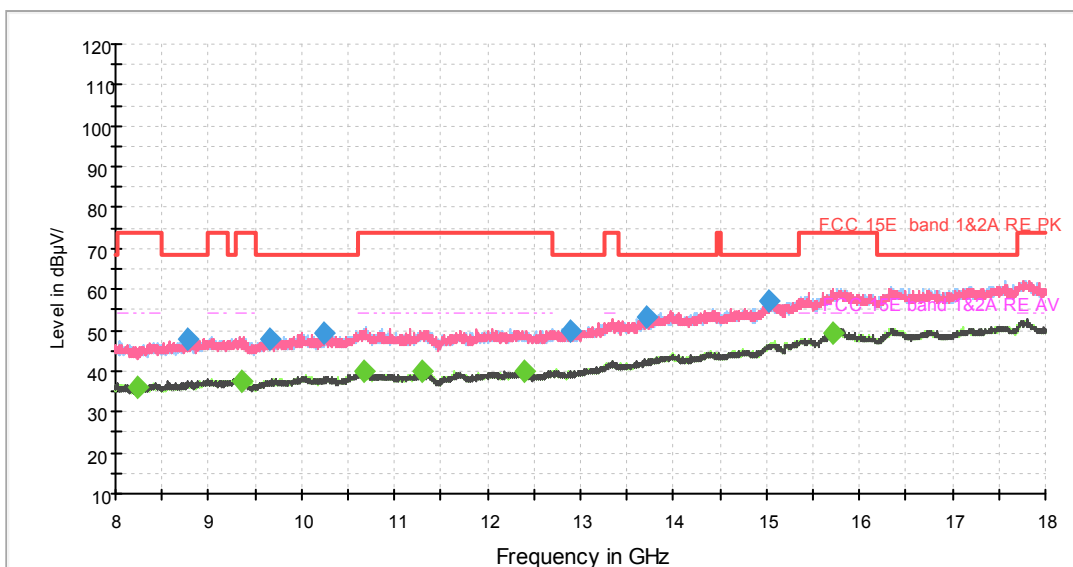

Radiates Emission from 8GHz to 18GHz

Frequency (MHz)	Peak (dBuV/m)	Height (cm)	Polarization	Azimuth (deg)	Correct Factor (dB)	Margin (dB)	Limit (dBuV/m)
1032.375000	43.9	100.0	H	0.0	-0.4	24.3	68.2
1245.875000	45.2	200.0	H	182.0	1.0	23.0	68.2
1994.000000	47.3	100.0	H	64.0	4.2	20.9	68.2
2645.000000	49.4	100.0	H	36.0	6.9	18.8	68.2
3079.875000	49.3	100.0	V	127.0	8.5	18.9	68.2



3479.750000	50.6	100.0	V	202.0	9.8	17.6	68.2
-------------	------	-------	---	-------	-----	------	------

Remark: 1. Correction Factor = Antenna factor+ Insertion loss (cable loss + amplifier gain)

Frequency (MHz)	Average (dBuV/m)	Height (cm)	Polarization	Azimuth (deg)	Correct Factor (dB)	Margin (dB)	Limit (dBuV/m)
1323.750000	34.3	100.0	H	318.0	1.3	19.7	54.0
1526.750000	34.6	200.0	H	39.0	2.2	19.4	54.0
2794.625000	38.1	200.0	H	23.0	7.4	15.9	54.0
3897.125000	42.0	200.0	H	112.0	11.1	12.0	54.0
4256.750000	42.3	200.0	H	55.0	12.3	11.7	54.0
4822.875000	42.7	200.0	H	105.0	13.3	11.3	54.0

Remark: 1. Correction Factor = Antenna factor+ Insertion loss (cable loss + amplifier gain)



802.11a CH60

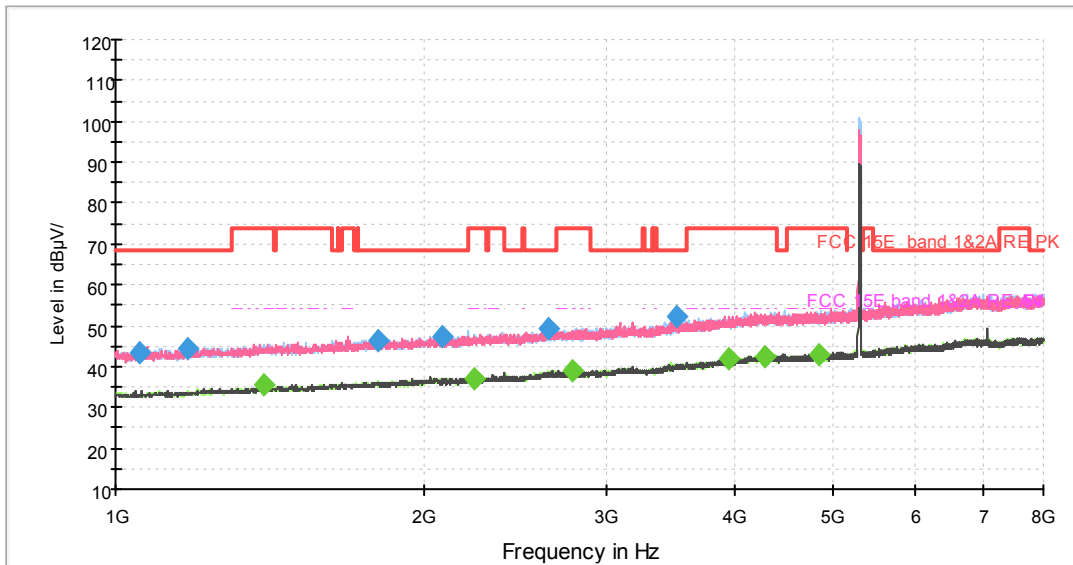

Note: The signal beyond the limit is carrier.
Radiates Emission from 1GHz to 8GHz

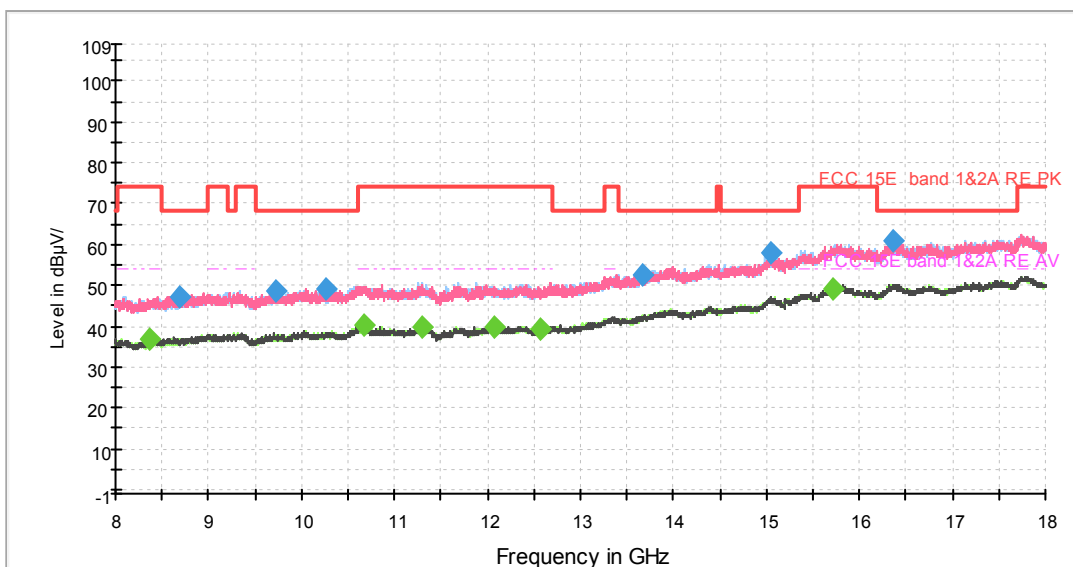

Radiates Emission from 8GHz to 18GHz

Frequency (MHz)	Peak (dBuV/m)	Height (cm)	Polarization	Azimuth (deg)	Correct Factor (dB)	Margin (dB)	Limit (dBuV/m)
1053.375000	43.6	200.0	H	72.0	-0.3	24.6	68.2
1176.750000	44.6	200.0	H	0.0	0.6	23.6	68.2
1798.000000	46.2	100.0	V	73.0	3.4	22.0	68.2
2081.500000	47.1	100.0	H	194.0	4.4	21.1	68.2
2642.375000	49.4	200.0	H	0.0	6.9	18.8	68.2



3521.750000	52.3	100.0	H	350.0	10.1	15.9	68.2
-------------	------	-------	---	-------	------	------	------

Remark: 1. Correction Factor = Antenna factor+ Insertion loss (cable loss + amplifier gain)

Frequency (MHz)	Average (dBuV/m)	Height (cm)	Polarization	Azimuth (deg)	Correct Factor (dB)	Margin (dB)	Limit (dBuV/m)
1392.875000	35.3	100.0	H	141.0	1.8	18.7	54.0
2232.875000	37.0	100.0	H	210.0	5.1	17.0	54.0
2784.125000	38.8	100.0	V	0.0	7.3	15.2	54.0
3948.750000	41.7	200.0	V	50.0	11.4	12.3	54.0
4277.750000	42.5	200.0	H	174.0	12.3	11.5	54.0
4847.375000	42.9	200.0	H	189.0	13.4	11.1	54.0

Remark: 1. Correction Factor = Antenna factor+ Insertion loss (cable loss + amplifier gain)



802.11a CH64

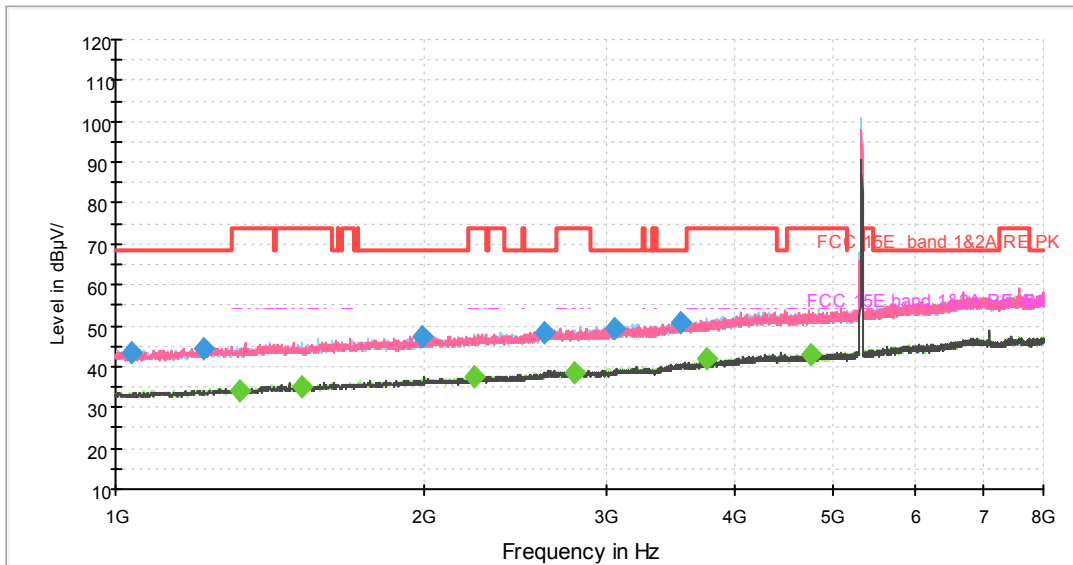

Note: The signal beyond the limit is carrier.
Radiates Emission from 1GHz to 8GHz

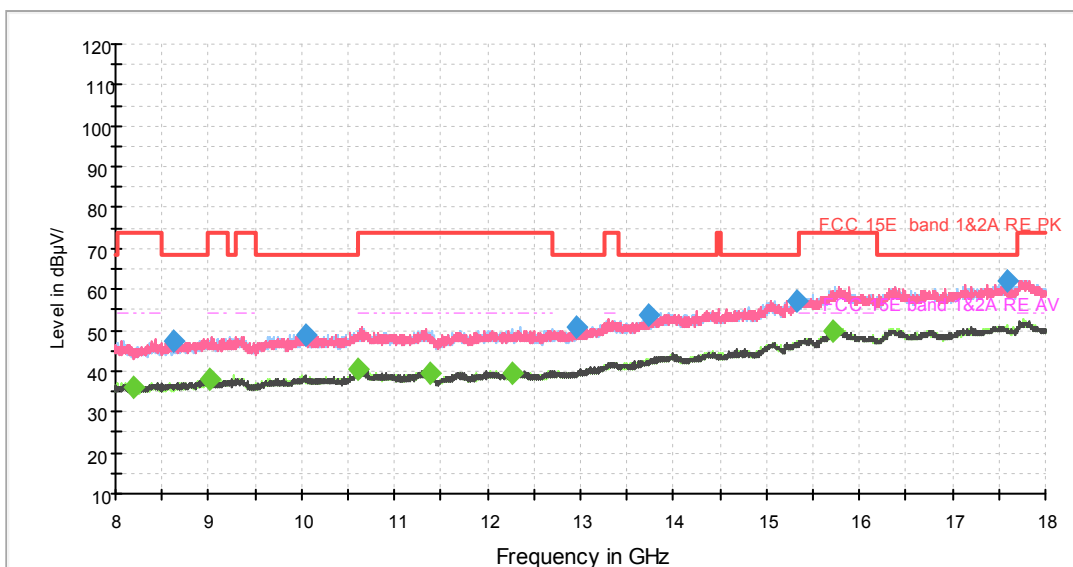

Radiates Emission from 8GHz to 18GHz

Frequency (MHz)	Peak (dBuV/m)	Height (cm)	Polarization	Azimuth (deg)	Correct Factor (dB)	Margin (dB)	Limit (dBuV/m)
1035.000000	43.3	100.0	V	62.0	-0.4	24.9	68.2
1218.750000	44.3	100.0	V	198.0	0.9	23.9	68.2
1990.500000	47.2	100.0	V	142.0	4.2	21.0	68.2
2610.875000	48.5	200.0	V	151.0	6.7	19.7	68.2
3060.625000	49.2	100.0	V	30.0	8.4	19.0	68.2



3544.500000	50.9	100.0	H	70.0	10.2	17.3	68.2
-------------	------	-------	---	------	------	------	------

Remark: 1. Correction Factor = Antenna factor+ Insertion loss (cable loss + amplifier gain)

Frequency (MHz)	Average (dBuV/m)	Height (cm)	Polarization	Azimuth (deg)	Correct Factor (dB)	Margin (dB)	Limit (dBuV/m)
1323.750000	34.1	100.0	V	150.0	1.3	19.9	54.0
1519.750000	35.3	100.0	H	259.0	2.2	18.7	54.0
2236.375000	37.6	100.0	H	314.0	5.1	16.4	54.0
2792.875000	38.7	100.0	V	95.0	7.4	15.3	54.0
3765.000000	41.7	200.0	V	293.0	10.6	12.3	54.0
4746.750000	42.8	100.0	V	273.0	13.2	11.2	54.0

Remark: 1. Correction Factor = Antenna factor+ Insertion loss (cable loss + amplifier gain)



802.11a CH100

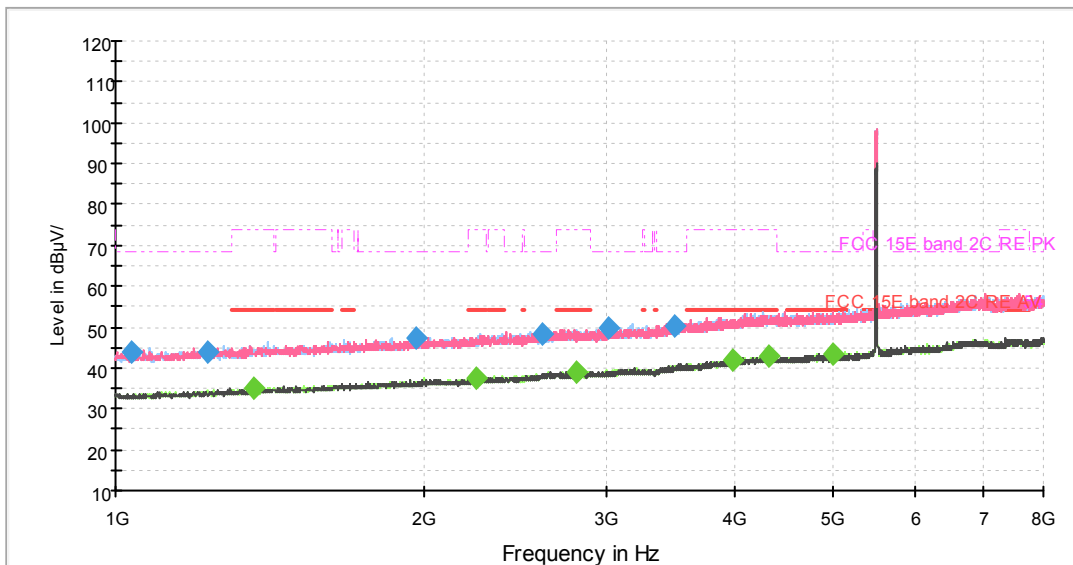

Note: The signal beyond the limit is carrier.
Radiates Emission from 1GHz to 8GHz

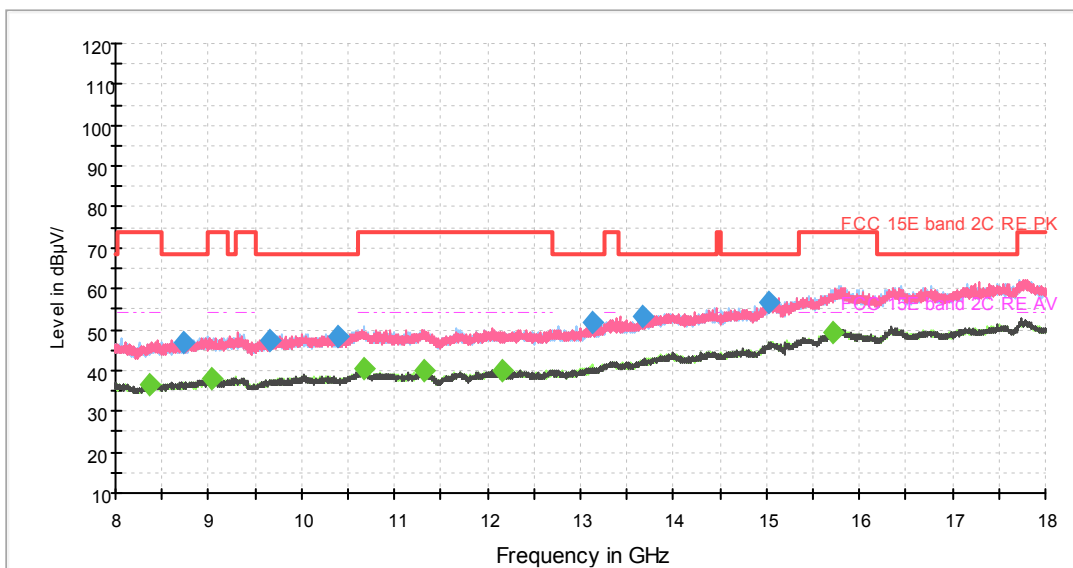

Radiates Emission from 8GHz to 18GHz

Frequency (MHz)	Peak (dBuV/m)	Height (cm)	Polarization	Azimuth (deg)	Correct Factor (dB)	Margin (dB)	Limit (dBuV/m)
1038.500000	43.6	200.0	H	318.0	-0.4	24.6	68.2
1228.375000	44.0	200.0	H	269.0	0.9	24.2	68.2
1961.625000	47.4	100.0	V	100.0	4.1	20.8	68.2
2603.000000	48.4	200.0	H	161.0	6.6	19.8	68.2
3024.750000	49.6	100.0	V	205.0	8.3	18.6	68.2



3501.625000	50.4	100.0	V	303.0	9.9	17.8	68.2
-------------	------	-------	---	-------	-----	------	------

Remark: 1. Correction Factor = Antenna factor+ Insertion loss (cable loss + amplifier gain)

Frequency (MHz)	Average (dBuV/m)	Height (cm)	Polarization	Azimuth (deg)	Correct Factor (dB)	Margin (dB)	Limit (dBuV/m)
1360.500000	35.1	100.0	V	107.0	1.6	18.9	54.0
2248.625000	37.4	200.0	H	261.0	5.2	16.6	54.0
2813.000000	39.1	200.0	V	74.0	7.4	14.9	54.0
3982.875000	41.7	200.0	V	159.0	11.5	12.3	54.0
4322.375000	42.8	200.0	H	131.0	12.4	11.2	54.0
4999.625000	43.2	100.0	V	43.0	13.6	10.8	54.0

Remark: 1. Correction Factor = Antenna factor+ Insertion loss (cable loss + amplifier gain)



802.11a CH116

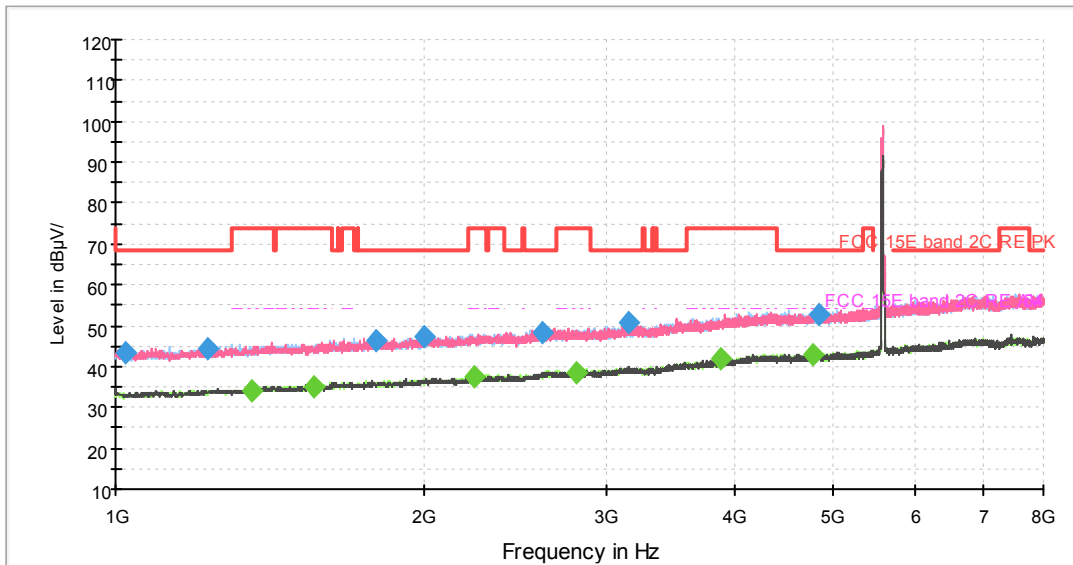

Note: The signal beyond the limit is carrier.
Radiates Emission from 1GHz to 8GHz

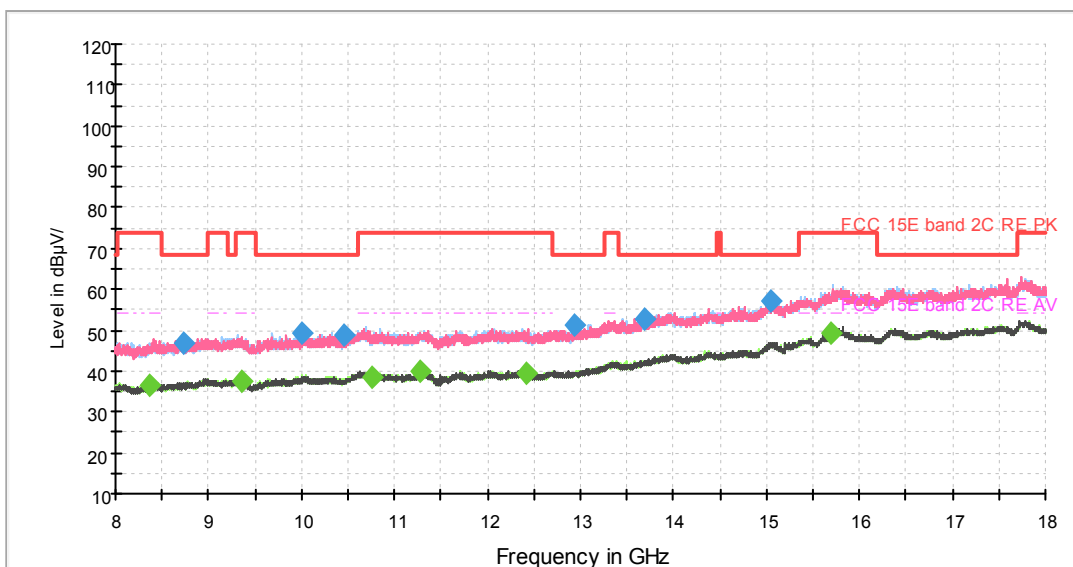

Radiates Emission from 8GHz to 18GHz

Frequency (MHz)	Peak (dBuV/m)	Height (cm)	Polarization	Azimuth (deg)	Correct Factor (dB)	Margin (dB)	Limit (dBuV/m)
1024.500000	43.3	100.0	V	41.0	-0.5	24.9	68.2
1228.375000	44.4	200.0	H	274.0	0.9	23.8	68.2
1795.375000	46.2	100.0	H	291.0	3.4	22.0	68.2
1994.000000	47.4	200.0	V	0.0	4.2	20.8	68.2
2605.625000	48.2	200.0	H	210.0	6.7	20.0	68.2



3151.625000	50.6	200.0	H	5.0	8.8	17.6	68.2
-------------	------	-------	---	-----	-----	------	------

Remark: 1. Correction Factor = Antenna factor+ Insertion loss (cable loss + amplifier gain)

Frequency (MHz)	Average (dBuV/m)	Height (cm)	Polarization	Azimuth (deg)	Correct Factor (dB)	Margin (dB)	Limit (dBuV/m)
1354.375000	34.1	100.0	H	283.0	1.5	19.9	54.0
1560.875000	35.3	100.0	V	81.0	2.3	18.7	54.0
2239.000000	37.6	100.0	H	307.0	5.1	16.4	54.0
2806.000000	38.5	100.0	H	168.0	7.4	15.5	54.0
3878.750000	41.7	200.0	V	137.0	11.1	12.3	54.0
4781.750000	42.7	200.0	H	326.0	13.3	11.3	54.0

Remark: 1. Correction Factor = Antenna factor+ Insertion loss (cable loss + amplifier gain)



802.11a CH140

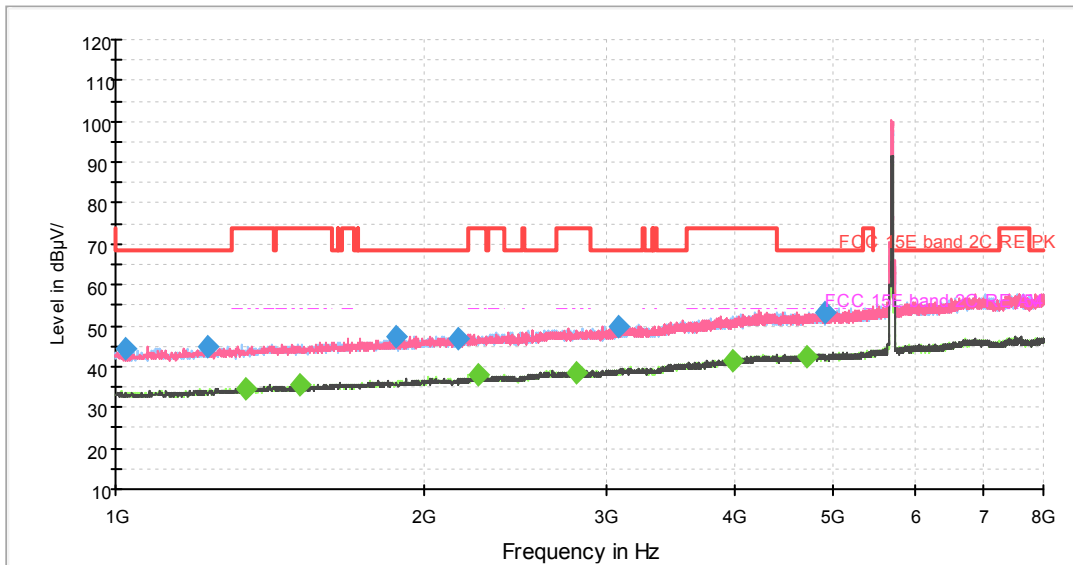

Note: The signal beyond the limit is carrier.
Radiates Emission from 1GHz to 8GHz

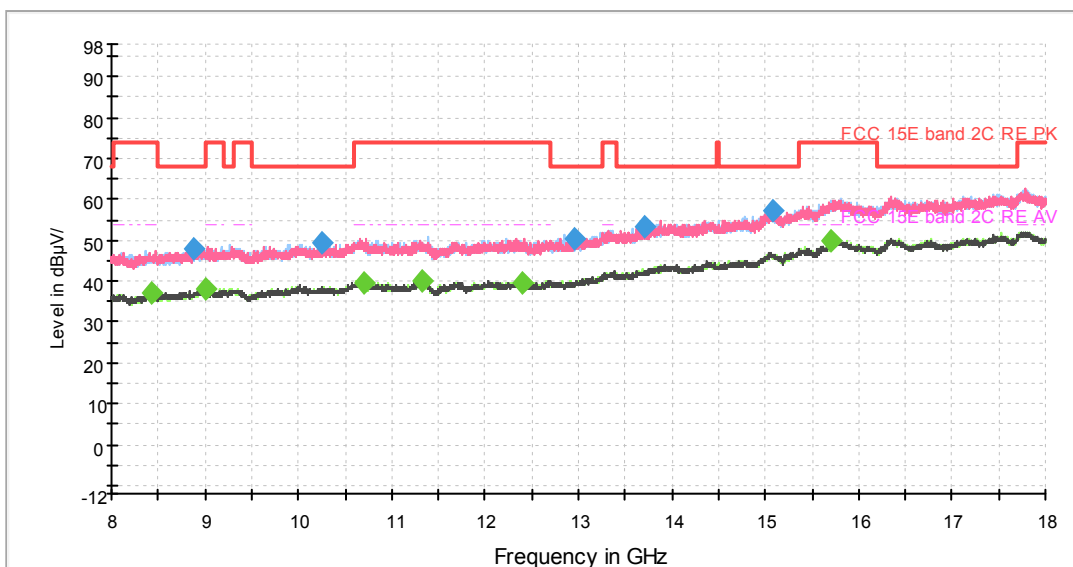

Radiates Emission from 8GHz to 18GHz

Frequency (MHz)	Peak (dBuV/m)	Height (cm)	Polarization	Azimuth (deg)	Correct Factor (dB)	Margin (dB)	Limit (dBuV/m)
1021.875000	44.6	200.0	V	196.0	-0.5	23.6	68.2
1231.000000	45.0	100.0	V	144.0	0.9	23.2	68.2
1872.375000	47.5	100.0	V	352.0	3.6	20.7	68.2
2151.500000	47.1	200.0	H	174.0	4.7	21.1	68.2
3093.000000	50.0	200.0	V	12.0	8.6	18.2	68.2



4899.000000	53.2	100.0	H	157.0	13.5	15.0	68.2
-------------	------	-------	---	-------	------	------	------

Remark: 1. Correction Factor = Antenna factor+ Insertion loss (cable loss + amplifier gain)

Frequency (MHz)	Average (dBuV/m)	Height (cm)	Polarization	Azimuth (deg)	Correct Factor (dB)	Margin (dB)	Limit (dBuV/m)
1341.250000	34.7	200.0	V	340.0	1.4	19.3	54.0
1508.375000	35.5	200.0	H	152.0	2.2	18.5	54.0
2253.875000	38.1	100.0	H	260.0	5.2	15.9	54.0
2805.125000	38.3	100.0	H	320.0	7.4	15.7	54.0
3996.000000	41.6	200.0	V	0.0	11.6	12.4	54.0
4717.000000	42.3	200.0	H	0.0	13.1	11.7	54.0

Remark: 1. Correction Factor = Antenna factor+ Insertion loss (cable loss + amplifier gain)



802.11a CH149

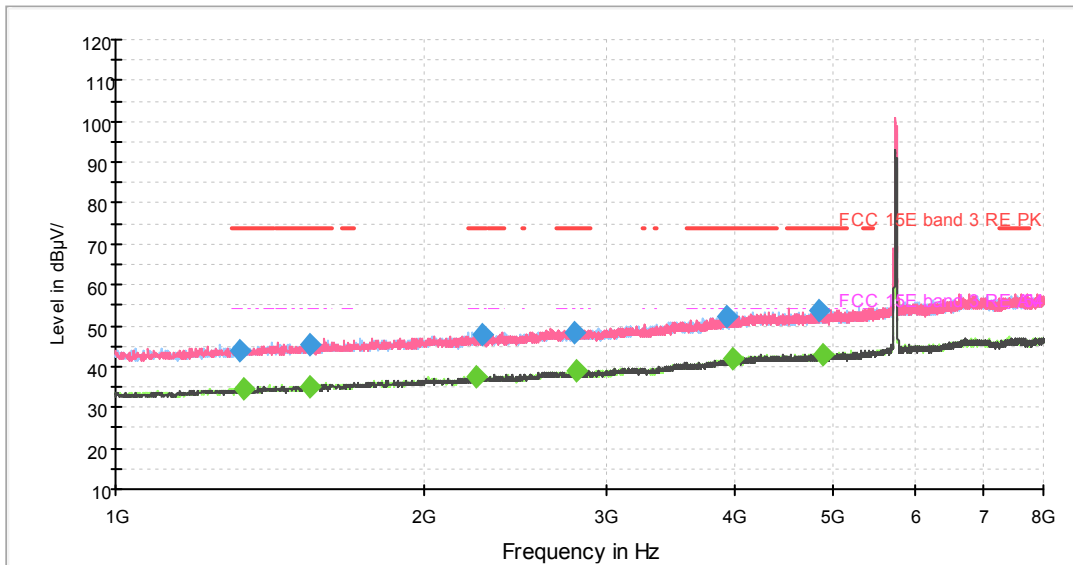

Note: The signal beyond the limit is carrier.
Radiates Emission from 1GHz to 8GHz

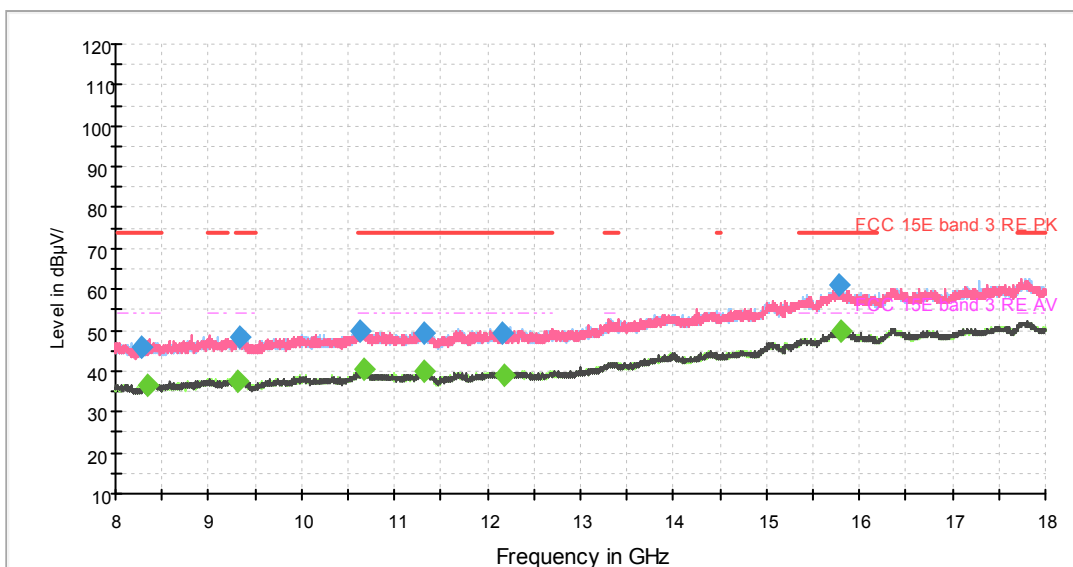

Radiates Emission from 8GHz to 18GHz

Frequency (MHz)	Peak (dBuV/m)	Height (cm)	Polarization	Azimuth (deg)	Correct Factor (dB)	Margin (dB)	Limit (dBuV/m)
1319.375000	44.0	200.0	H	173.0	1.3	30.0	74.0
1544.250000	45.1	100.0	V	57.0	2.3	28.9	74.0
2276.625000	47.6	200.0	H	103.0	5.3	26.4	74.0
2793.750000	48.5	100.0	V	119.0	7.4	25.5	74.0
3938.250000	52.2	100.0	H	192.0	11.3	21.8	74.0



4837.750000	53.5	200.0	H	42.0	13.4	20.5	74.0
-------------	------	-------	---	------	------	------	------

Remark: 1. Correction Factor = Antenna factor+ Insertion loss (cable loss + amplifier gain)

Frequency (MHz)	Average (dBuV/m)	Height (cm)	Polarization	Azimuth (deg)	Correct Factor (dB)	Margin (dB)	Limit (dBuV/m)
1335.125000	34.3	200.0	H	293.0	1.4	19.7	54.0
1543.375000	35.3	200.0	H	219.0	2.3	18.7	54.0
2241.625000	37.6	100.0	H	261.0	5.1	16.4	54.0
2805.125000	38.8	100.0	V	25.0	7.4	15.2	54.0
3979.375000	41.7	100.0	V	218.0	11.5	12.3	54.0
4889.375000	42.7	200.0	H	87.0	13.5	11.3	54.0

Remark: 1. Correction Factor = Antenna factor+ Insertion loss (cable loss + amplifier gain)



802.11a CH149

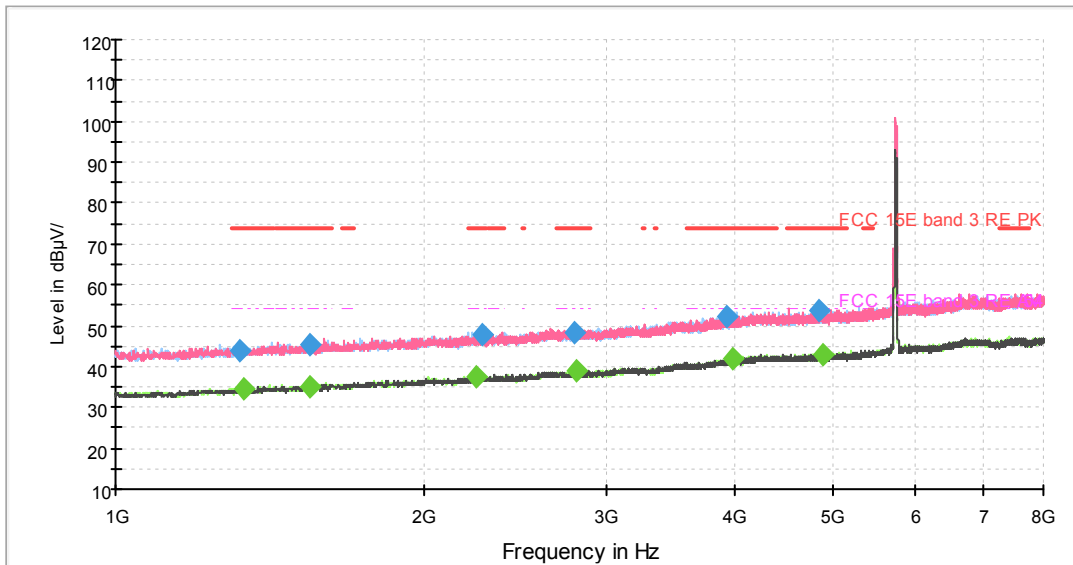

Note: The signal beyond the limit is carrier.
Radiates Emission from 1GHz to 8GHz

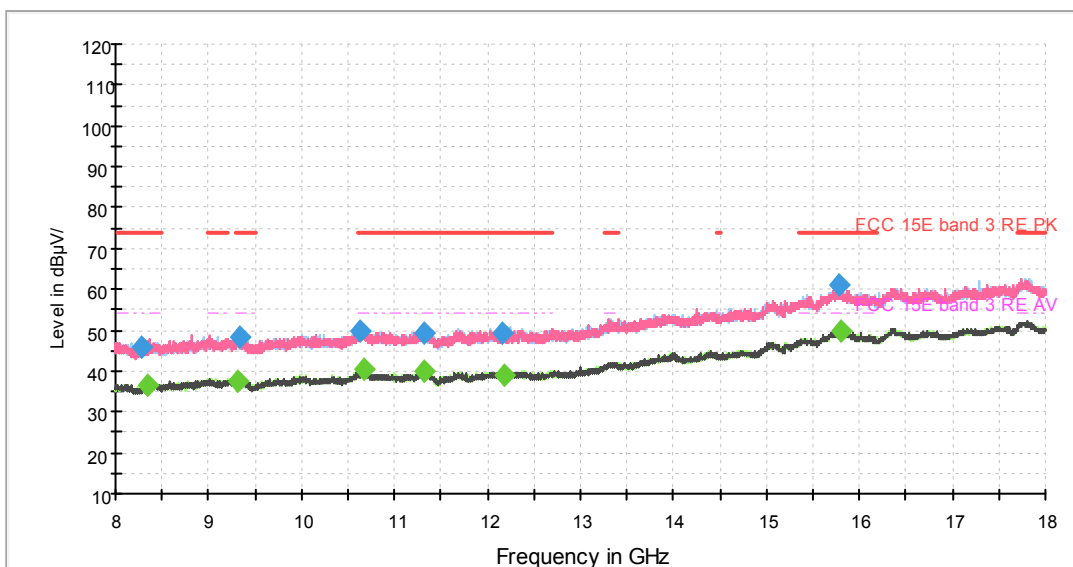

Radiates Emission from 8GHz to 18GHz

Frequency (MHz)	Peak (dBuV/m)	Height (cm)	Polarization	Azimuth (deg)	Correct Factor (dB)	Margin (dB)	Limit (dBuV/m)
1319.375000	44.0	200.0	H	173.0	1.3	30.0	74.0
1544.250000	45.1	100.0	V	57.0	2.3	28.9	74.0
2276.625000	47.6	200.0	H	103.0	5.3	26.4	74.0
2793.750000	48.5	100.0	V	119.0	7.4	25.5	74.0
3938.250000	52.2	100.0	H	192.0	11.3	21.8	74.0



4837.750000	53.5	200.0	H	42.0	13.4	20.5	74.0
-------------	------	-------	---	------	------	------	------

Remark: 1. Correction Factor = Antenna factor+ Insertion loss (cable loss + amplifier gain)

Frequency (MHz)	Average (dBuV/m)	Height (cm)	Polarization	Azimuth (deg)	Correct Factor (dB)	Margin (dB)	Limit (dBuV/m)
1335.125000	34.3	200.0	H	293.0	1.4	19.7	54.0
1543.375000	35.3	200.0	H	219.0	2.3	18.7	54.0
2241.625000	37.6	100.0	H	261.0	5.1	16.4	54.0
2805.125000	38.8	100.0	V	25.0	7.4	15.2	54.0
3979.375000	41.7	100.0	V	218.0	11.5	12.3	54.0
4889.375000	42.7	200.0	H	87.0	13.5	11.3	54.0

Remark: 1. Correction Factor = Antenna factor+ Insertion loss (cable loss + amplifier gain)



802.11a CH157

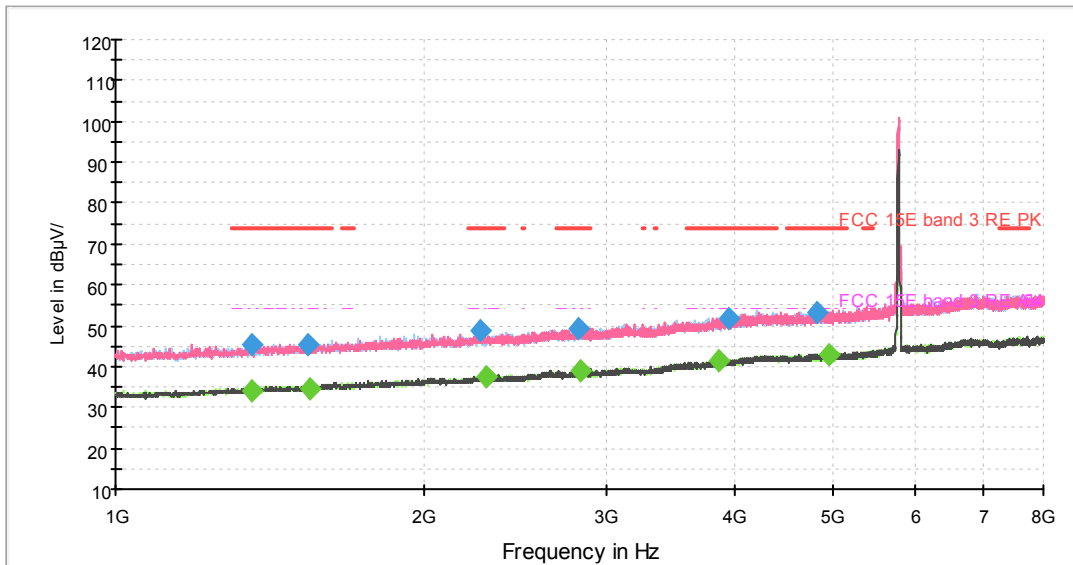

Note: The signal beyond the limit is carrier.
Radiates Emission from 1GHz to 8GHz

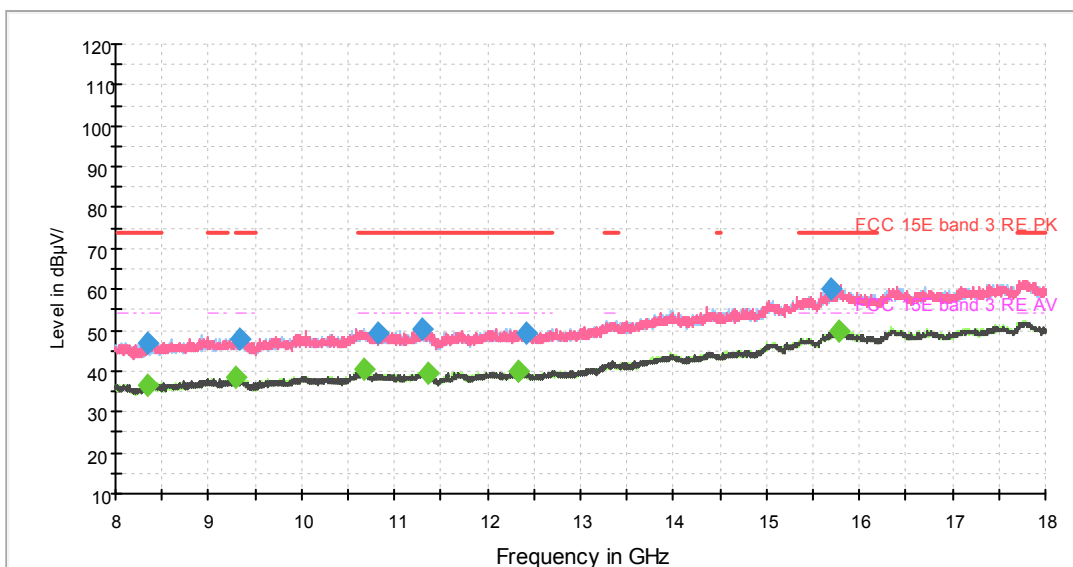

Radiates Emission from 8GHz to 18GHz

Frequency (MHz)	Peak (dBuV/m)	Height (cm)	Polarization	Azimuth (deg)	Correct Factor (dB)	Margin (dB)	Limit (dBuV/m)
1355.250000	45.2	100.0	V	25.0	1.5	28.8	74.0
1540.750000	45.3	100.0	V	155.0	2.2	28.7	74.0
2260.000000	49.0	100.0	V	194.0	5.2	25.0	74.0
2816.500000	49.0	100.0	H	112.0	7.4	25.0	74.0
3956.625000	52.0	200.0	V	227.0	11.4	22.0	74.0



4822.000000	53.3	200.0	V	353.0	13.3	20.7	74.0
-------------	------	-------	---	-------	------	------	------

Remark: 1. Correction Factor = Antenna factor+ Insertion loss (cable loss + amplifier gain)

Frequency (MHz)	Average (dBuV/m)	Height (cm)	Polarization	Azimuth (deg)	Correct Factor (dB)	Margin (dB)	Limit (dBuV/m)
1355.250000	34.3	200.0	H	92.0	1.5	19.7	54.0
1546.000000	34.7	200.0	H	108.0	2.3	19.3	54.0
2292.375000	37.7	200.0	H	92.0	5.4	16.3	54.0
2831.375000	38.9	200.0	H	259.0	7.5	15.1	54.0
3870.875000	41.5	100.0	H	128.0	11.0	12.5	54.0
4943.625000	42.7	100.0	V	340.0	13.5	11.3	54.0

Remark: 1. Correction Factor = Antenna factor+ Insertion loss (cable loss + amplifier gain)



802.11a CH165

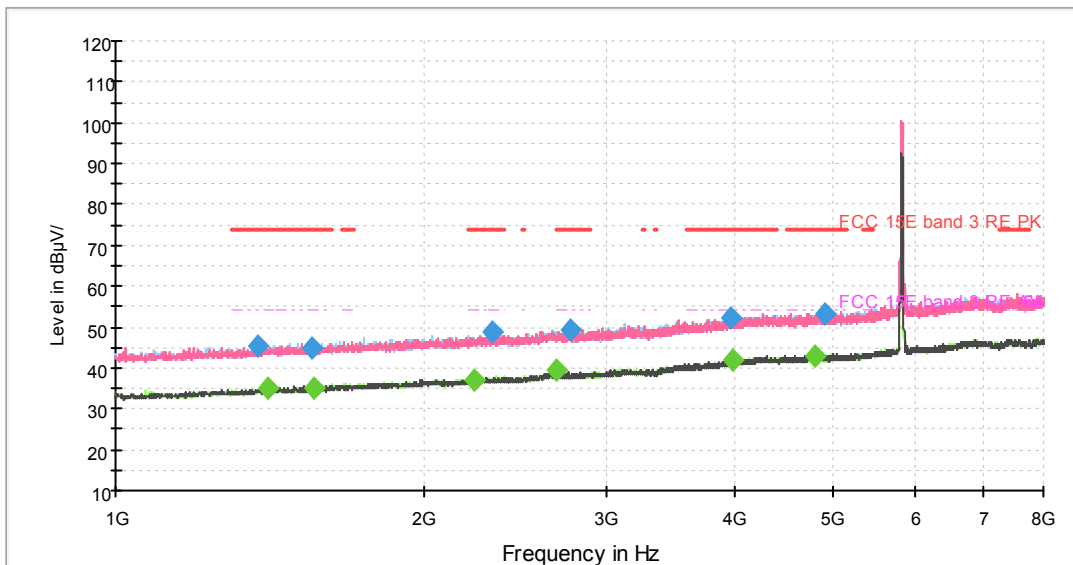

Note: The signal beyond the limit is carrier.
Radiates Emission from 1GHz to 8GHz

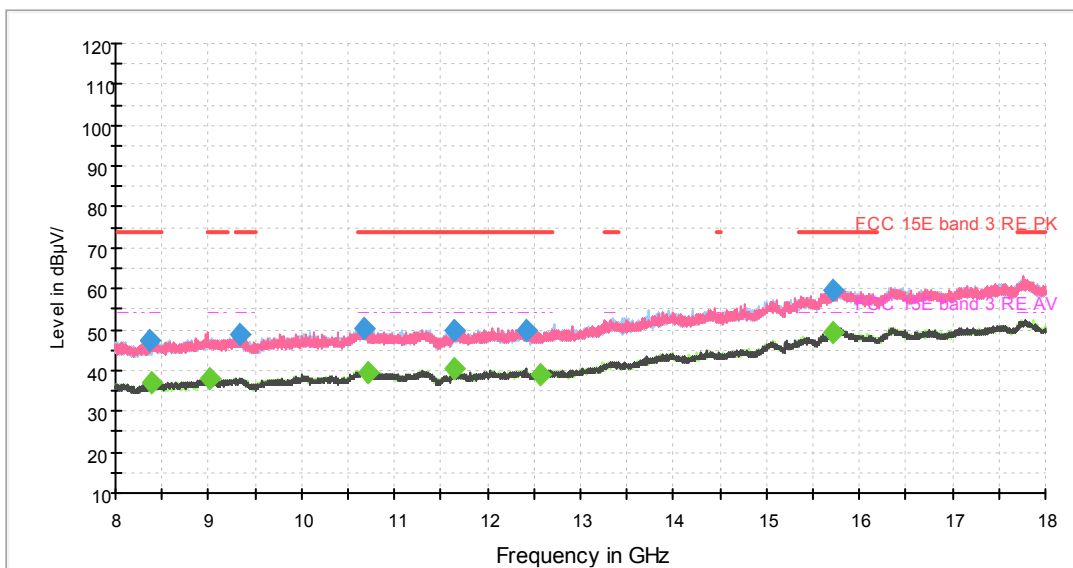

Radiates Emission from 8GHz to 18GHz

Frequency (MHz)	Peak (dBUV/m)	Height (cm)	Polarization	Azimuth (deg)	Correct Factor (dB)	Margin (dB)	Limit (dBUV/m)
1378.000000	45.6	100.0	V	66.0	1.7	28.4	74.0
1549.500000	45.1	100.0	H	138.0	2.3	28.9	74.0
2326.500000	48.6	200.0	H	47.0	5.5	25.4	74.0
2765.750000	49.2	200.0	V	28.0	7.3	24.8	74.0
3968.875000	52.1	100.0	V	309.0	11.4	21.9	74.0



4898.125000	53.2	200.0	H	31.0	13.5	20.8	74.0
-------------	------	-------	---	------	------	------	------

Remark: 1. Correction Factor = Antenna factor+ Insertion loss (cable loss + amplifier gain)

Frequency (MHz)	Average (dBuV/m)	Height (cm)	Polarization	Azimuth (deg)	Correct Factor (dB)	Margin (dB)	Limit (dBuV/m)
1408.625000	35.2	200.0	H	105.0	1.9	18.8	54.0
1561.750000	35.2	200.0	H	80.0	2.3	18.8	54.0
2238.125000	37.1	200.0	V	0.0	5.1	16.9	54.0
2689.625000	39.3	100.0	H	163.0	7.0	14.7	54.0
3992.500000	41.7	200.0	V	0.0	11.5	12.3	54.0
4804.500000	42.8	100.0	V	33.0	13.3	11.2	54.0

Remark: 1. Correction Factor = Antenna factor+ Insertion loss (cable loss + amplifier gain)



802.11n (HT20) CH36

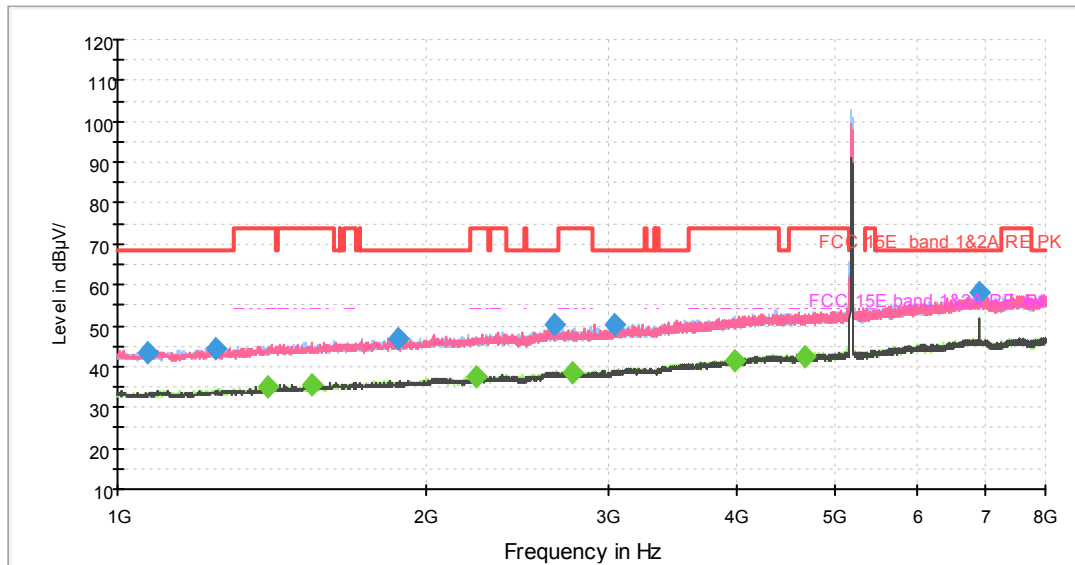

Note: The signal beyond the limit is carrier.
Radiates Emission from 1GHz to 8GHz

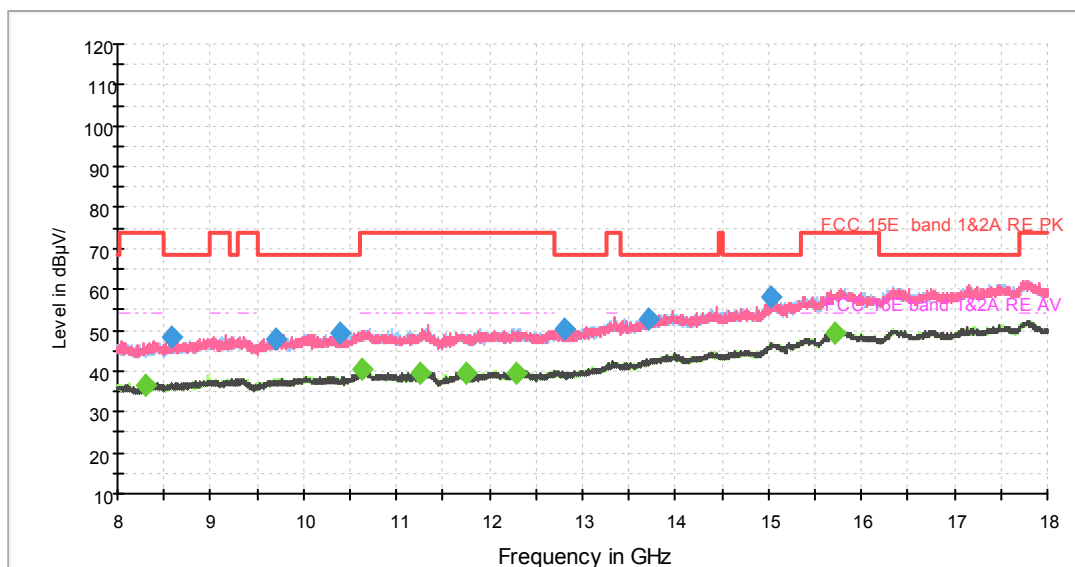

Radiates Emission from 8GHz to 18GHz

Frequency (MHz)	Peak (dBuV/m)	Height (cm)	Polarization	Azimuth (deg)	Correct Factor (dB)	Margin (dB)	Limit (dBuV/m)
1069.125000	43.6	100.0	V	183.0	-0.2	24.6	68.2
1248.500000	44.2	100.0	H	141.0	1.0	24.0	68.2
1873.250000	47.0	200.0	H	197.0	3.6	21.2	68.2
2666.000000	50.1	200.0	V	50.0	6.9	18.1	68.2
3044.875000	50.2	100.0	H	232.0	8.4	18.0	68.2



6907.125000	58.1	100.0	V	151.0	17.7	10.1	68.2
-------------	------	-------	---	-------	------	------	------

Remark: 1. Correction Factor = Antenna factor+ Insertion loss (cable loss + amplifier gain)

Frequency (MHz)	Average (dBuV/m)	Height (cm)	Polarization	Azimuth (deg)	Correct Factor (dB)	Margin (dB)	Limit (dBuV/m)
1402.500000	35.3	200.0	V	0.0	1.9	18.7	54.0
1545.125000	35.5	200.0	V	348.0	2.3	18.5	54.0
2238.125000	37.4	200.0	V	0.0	5.1	16.6	54.0
2766.625000	38.5	100.0	H	132.0	7.3	15.5	54.0
3990.750000	41.4	100.0	H	186.0	11.5	12.6	54.0
4661.875000	42.6	100.0	H	28.0	13.0	11.4	54.0

Remark: 1. Correction Factor = Antenna factor+ Insertion loss (cable loss + amplifier gain)



802.11n (HT20) CH40

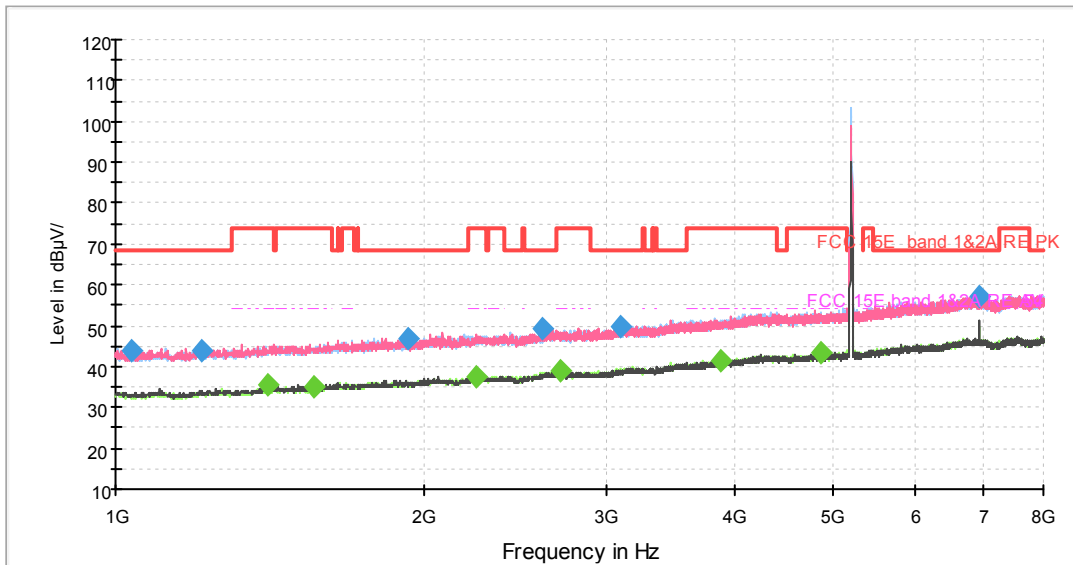

Note: The signal beyond the limit is carrier.
Radiates Emission from 1GHz to 8GHz

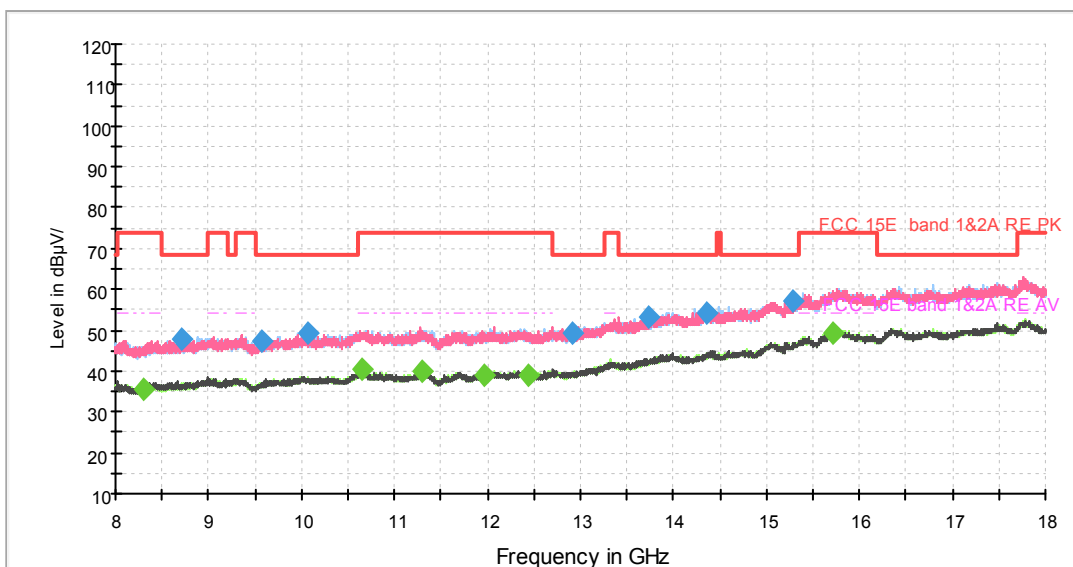

Radiates Emission from 8GHz to 18GHz

Frequency (MHz)	Peak (dBuV/m)	Height (cm)	Polarization	Azimuth (deg)	Correct Factor (dB)	Margin (dB)	Limit (dBuV/m)
1035.875000	43.9	100.0	H	101.0	-0.4	24.3	68.2
1215.250000	44.1	200.0	H	115.0	0.8	24.1	68.2
1930.125000	47.0	100.0	V	308.0	3.9	21.2	68.2
2602.125000	49.4	100.0	V	133.0	6.6	18.8	68.2
3105.250000	49.9	100.0	H	143.0	8.6	18.3	68.2



6933.375000	57.4	100.0	V	154.0	17.7	10.8	68.2
-------------	------	-------	---	-------	------	------	------

Remark: 1. Correction Factor = Antenna factor+ Insertion loss (cable loss + amplifier gain)

Frequency (MHz)	Average (dBuV/m)	Height (cm)	Polarization	Azimuth (deg)	Correct Factor (dB)	Margin (dB)	Limit (dBuV/m)
1406.000000	35.4	200.0	V	9.0	1.9	18.6	54.0
1556.500000	35.0	100.0	V	111.0	2.3	19.0	54.0
2243.375000	37.7	100.0	H	126.0	5.2	16.3	54.0
2710.625000	38.7	200.0	H	0.0	7.1	15.3	54.0
3873.500000	41.7	200.0	V	352.0	11.0	12.3	54.0
4865.750000	43.3	200.0	H	247.0	13.4	10.7	54.0

Remark: 1. Correction Factor = Antenna factor+ Insertion loss (cable loss + amplifier gain)



802.11n (HT20) CH48

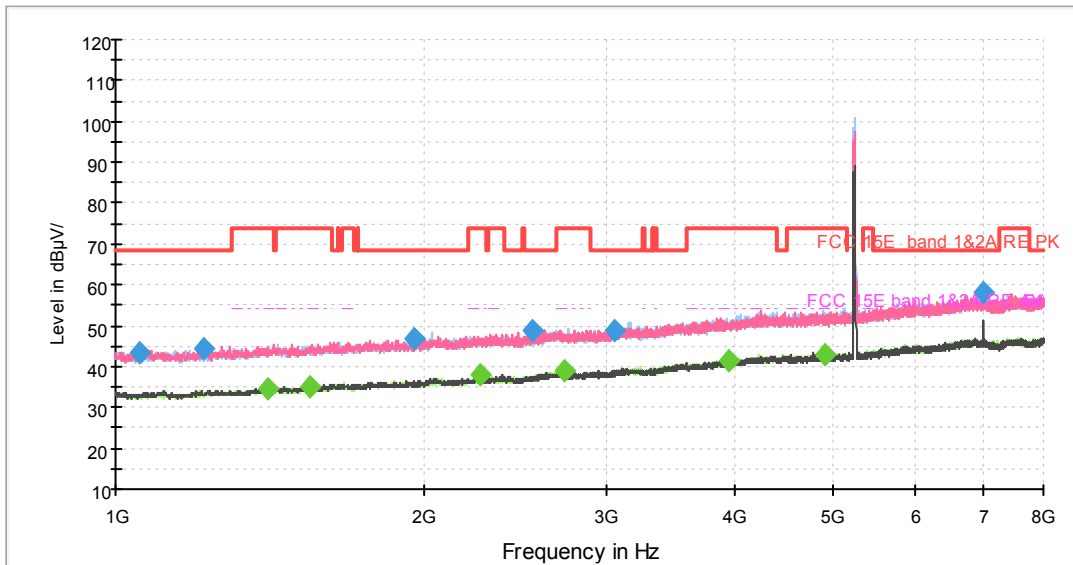

Note: The signal beyond the limit is carrier.
Radiates Emission from 1GHz to 8GHz

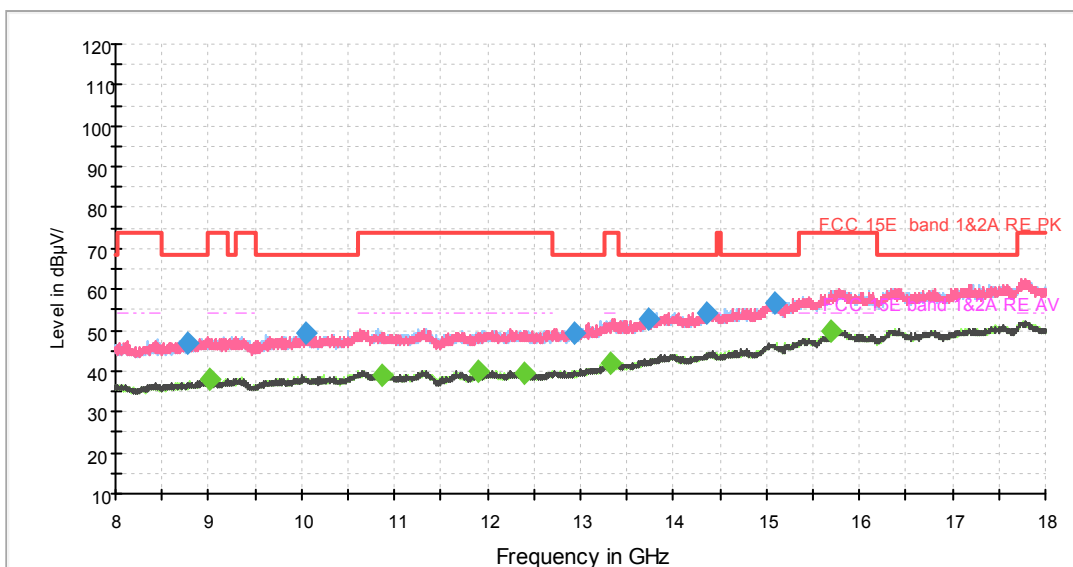

Radiates Emission from 8GHz to 18GHz

Frequency (MHz)	Peak (dBuV/m)	Height (cm)	Polarization	Azimuth (deg)	Correct Factor (dB)	Margin (dB)	Limit (dBuV/m)
1053.375000	43.3	100.0	V	359.0	-0.3	24.9	68.2
1216.125000	44.4	100.0	V	84.0	0.8	23.8	68.2
1951.125000	46.9	100.0	H	268.0	4.0	21.3	68.2
2549.625000	48.9	100.0	V	43.0	6.3	19.3	68.2
3061.500000	48.9	100.0	H	358.0	8.4	19.3	68.2



6987.625000	58.0	100.0	V	0.0	17.8	10.2	68.2
-------------	------	-------	---	-----	------	------	------

Remark: 1. Correction Factor = Antenna factor+ Insertion loss (cable loss + amplifier gain)

Frequency (MHz)	Average (dBuV/m)	Height (cm)	Polarization	Azimuth (deg)	Correct Factor (dB)	Margin (dB)	Limit (dBuV/m)
1409.500000	34.7	100.0	V	287.0	1.9	19.3	54.0
1546.875000	35.0	100.0	H	268.0	2.3	19.0	54.0
2263.500000	37.8	100.0	V	343.0	5.3	16.2	54.0
2739.500000	38.8	100.0	H	350.0	7.2	15.2	54.0
3954.000000	41.5	100.0	H	169.0	11.4	12.5	54.0
4894.625000	43.1	100.0	H	284.0	13.5	10.9	54.0

Remark: 1. Correction Factor = Antenna factor+ Insertion loss (cable loss + amplifier gain)



802.11n (HT20) CH52

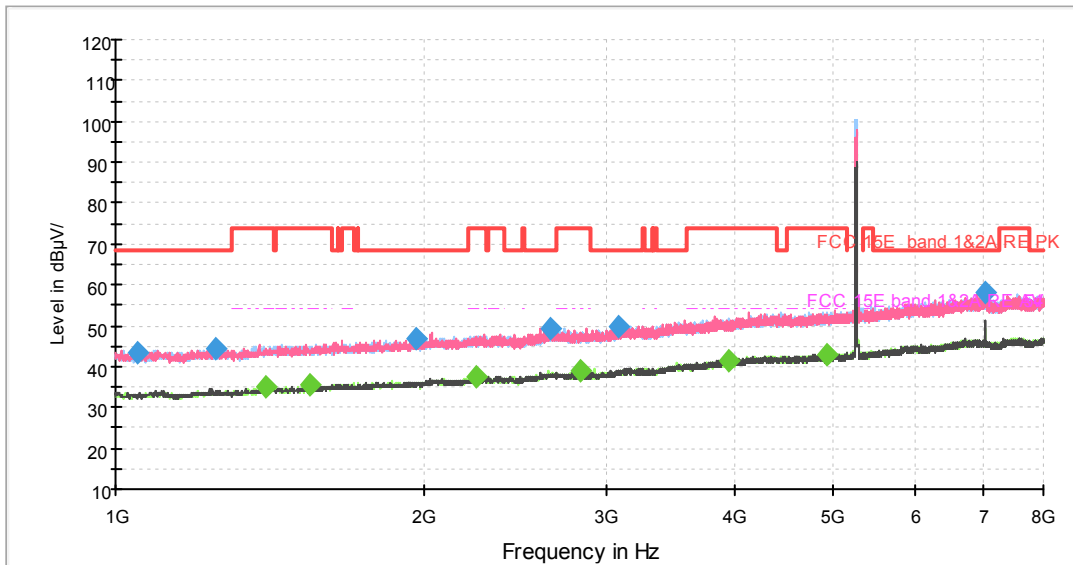

Note: The signal beyond the limit is carrier.
Radiates Emission from 1GHz to 8GHz

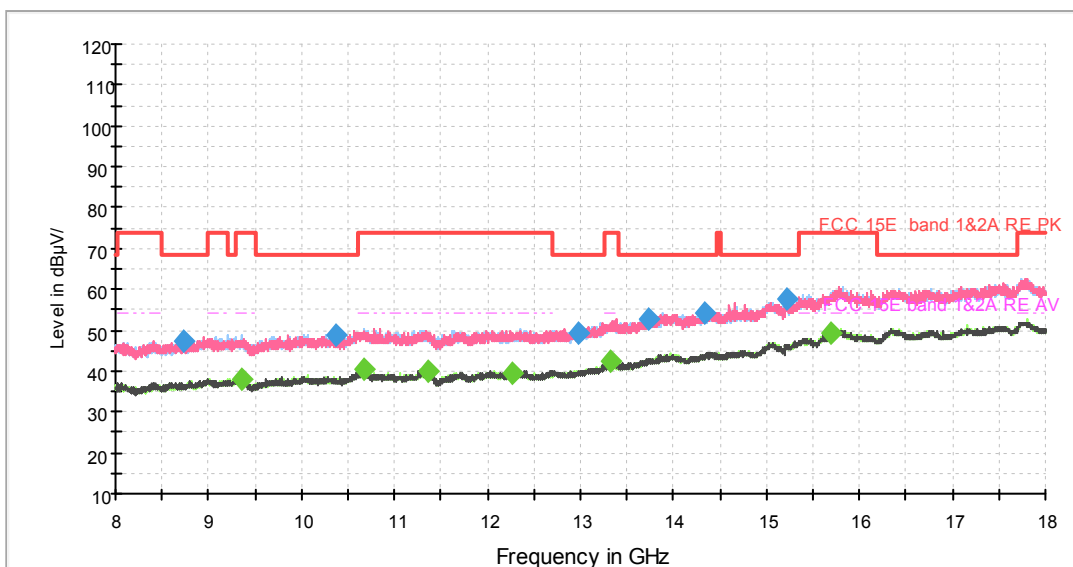

Radiates Emission from 8GHz to 18GHz

Frequency (MHz)	Peak (dBuV/m)	Height (cm)	Polarization	Azimuth (deg)	Correct Factor (dB)	Margin (dB)	Limit (dBuV/m)
1049.000000	43.4	100.0	V	247.0	-0.4	24.8	68.2
1252.875000	44.1	100.0	V	332.0	1.0	24.1	68.2
1961.625000	46.9	100.0	H	308.0	4.1	21.3	68.2
2648.500000	49.3	100.0	H	357.0	6.9	18.9	68.2
3091.250000	49.8	100.0	H	234.0	8.6	18.4	68.2



7013.000000	58.1	100.0	V	2.0	17.8	10.1	68.2
-------------	------	-------	---	-----	------	------	------

Remark: 1. Correction Factor = Antenna factor+ Insertion loss (cable loss + amplifier gain)

Frequency (MHz)	Average (dBuV/m)	Height (cm)	Polarization	Azimuth (deg)	Correct Factor (dB)	Margin (dB)	Limit (dBuV/m)
1402.500000	34.9	100.0	V	122.0	1.9	19.1	54.0
1545.125000	35.5	100.0	V	255.0	2.3	18.5	54.0
2239.875000	37.5	100.0	V	288.0	5.1	16.5	54.0
2838.375000	38.9	100.0	V	139.0	7.5	15.1	54.0
3948.750000	41.5	100.0	H	341.0	11.4	12.5	54.0
4924.375000	43.0	100.0	V	0.0	13.5	11.0	54.0

Remark: 1. Correction Factor = Antenna factor+ Insertion loss (cable loss + amplifier gain)



802.11n (HT20) CH60

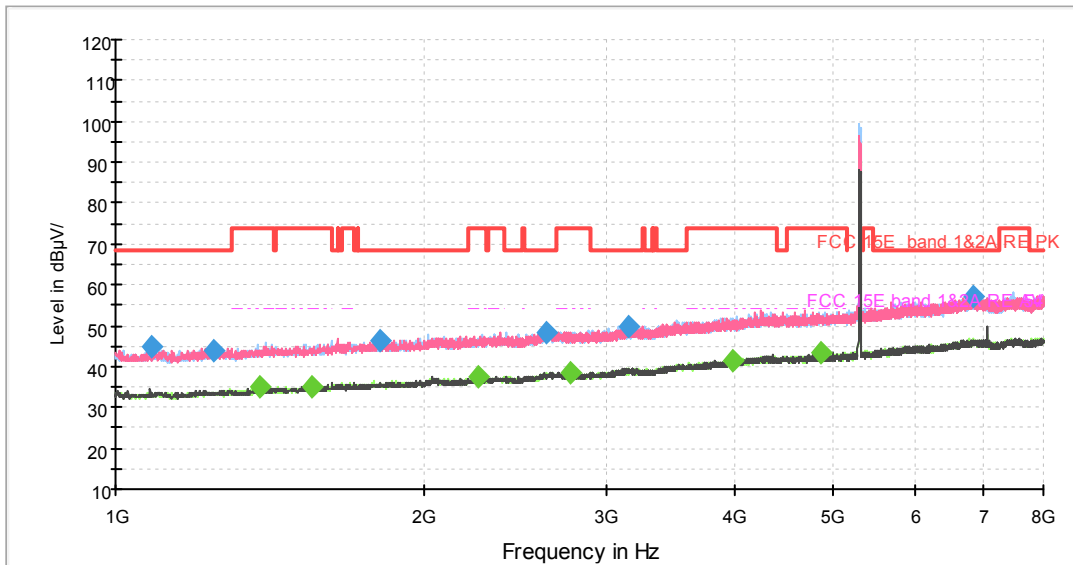

Note: The signal beyond the limit is carrier.
Radiates Emission from 1GHz to 8GHz

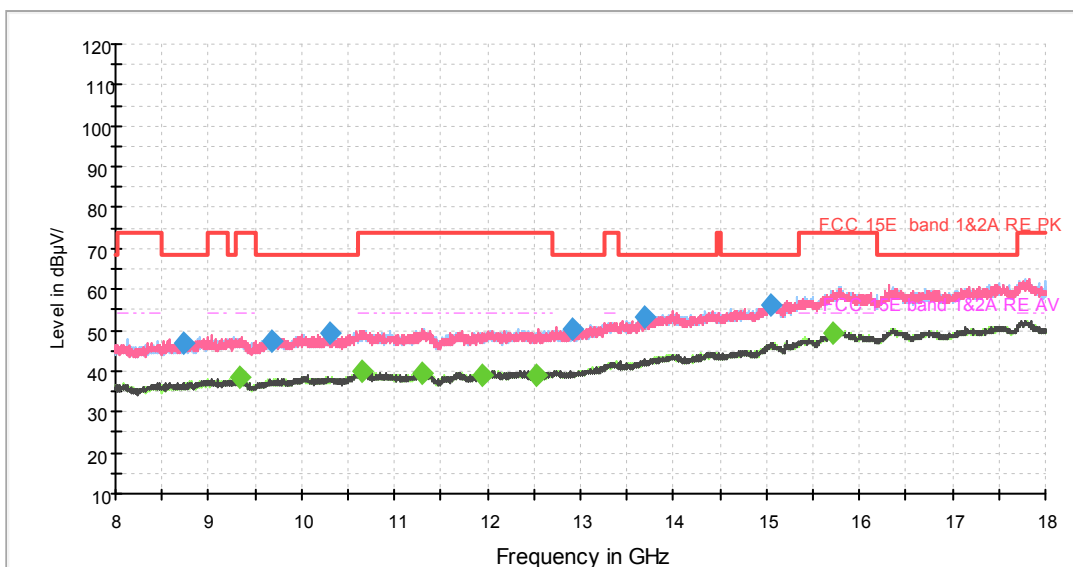

Radiates Emission from 8GHz to 18GHz

Frequency (MHz)	Peak (dBuV/m)	Height (cm)	Polarization	Azimuth (deg)	Correct Factor (dB)	Margin (dB)	Limit (dBuV/m)
1086.625000	44.7	100.0	V	200.0	-0.1	23.5	68.2
1248.500000	43.9	100.0	V	61.0	1.0	24.3	68.2
1808.500000	46.3	100.0	H	193.0	3.5	21.9	68.2
2624.875000	48.5	100.0	H	210.0	6.8	19.7	68.2
3150.750000	50.0	100.0	H	177.0	8.8	18.2	68.2



6839.750000	57.2	100.0	V	200.0	17.7	11.0	68.2
-------------	------	-------	---	-------	------	------	------

Remark: 1. Correction Factor = Antenna factor+ Insertion loss (cable loss + amplifier gain)

Frequency (MHz)	Average (dBuV/m)	Height (cm)	Polarization	Azimuth (deg)	Correct Factor (dB)	Margin (dB)	Limit (dBuV/m)
1379.750000	34.9	100.0	H	282.0	1.7	19.1	54.0
1550.375000	35.1	100.0	V	69.0	2.3	18.9	54.0
2256.500000	37.5	100.0	V	78.0	5.2	16.5	54.0
2775.375000	38.3	100.0	V	11.0	7.3	15.7	54.0
3983.750000	41.5	100.0	V	184.0	11.5	12.5	54.0
4865.750000	43.3	100.0	H	339.0	13.4	10.7	54.0

Remark: 1. Correction Factor = Antenna factor+ Insertion loss (cable loss + amplifier gain)



802.11n (HT20) CH64

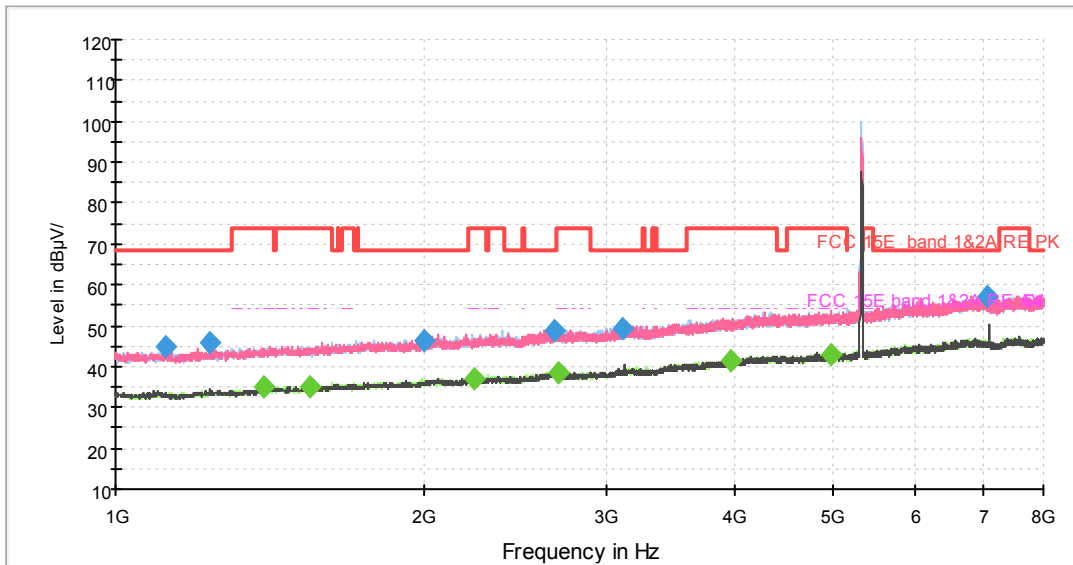

Note: The signal beyond the limit is carrier.
Radiates Emission from 1GHz to 8GHz

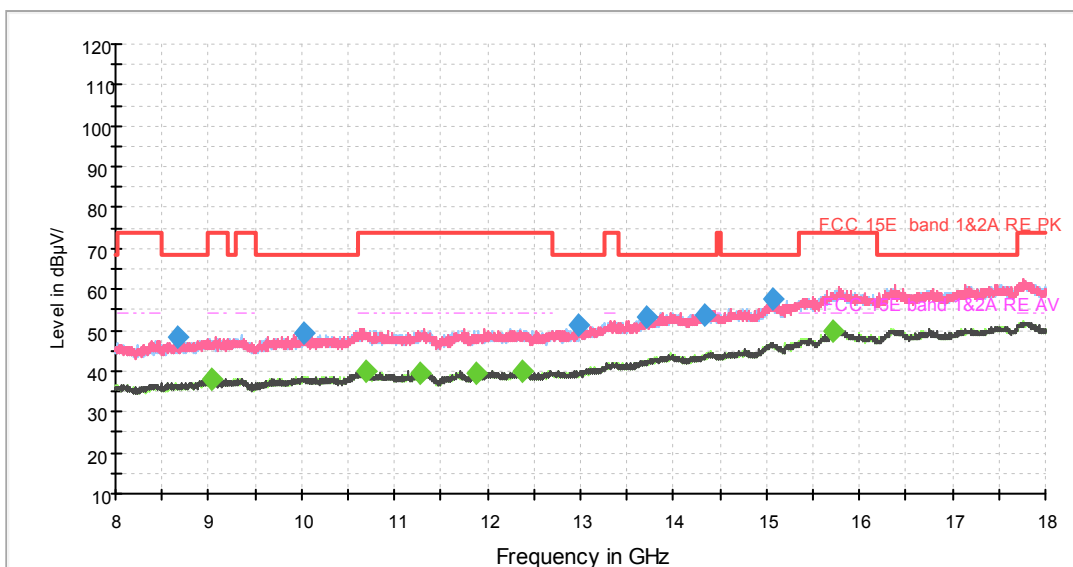

Radiates Emission from 8GHz to 18GHz

Frequency (MHz)	Peak (dBuV/m)	Height (cm)	Polarization	Azimuth (deg)	Correct Factor (dB)	Margin (dB)	Limit (dBuV/m)
1120.750000	44.6	100.0	H	0.0	0.2	23.6	68.2
1237.125000	46.0	100.0	V	283.0	0.9	22.2	68.2
1994.000000	46.6	100.0	V	7.0	4.2	21.6	68.2
2675.625000	49.0	100.0	H	244.0	7.0	19.2	68.2
3110.500000	49.5	100.0	H	211.0	8.7	18.7	68.2



7058.500000	57.0	100.0	H	269.0	17.9	11.2	68.2
-------------	------	-------	---	-------	------	------	------

Remark: 1. Correction Factor = Antenna factor+ Insertion loss (cable loss + amplifier gain)

Frequency (MHz)	Average (dBuV/m)	Height (cm)	Polarization	Azimuth (deg)	Correct Factor (dB)	Margin (dB)	Limit (dBuV/m)
1392.000000	35.2	100.0	V	36.0	1.8	18.8	54.0
1545.125000	35.1	100.0	H	141.0	2.3	18.9	54.0
2233.750000	37.0	100.0	H	0.0	5.1	17.0	54.0
2703.625000	38.6	100.0	H	319.0	7.1	15.4	54.0
3962.750000	41.4	100.0	V	124.0	11.4	12.6	54.0
4975.125000	43.0	100.0	V	44.0	13.6	11.0	54.0

Remark: 1. Correction Factor = Antenna factor+ Insertion loss (cable loss + amplifier gain)



802.11n (HT20) CH100

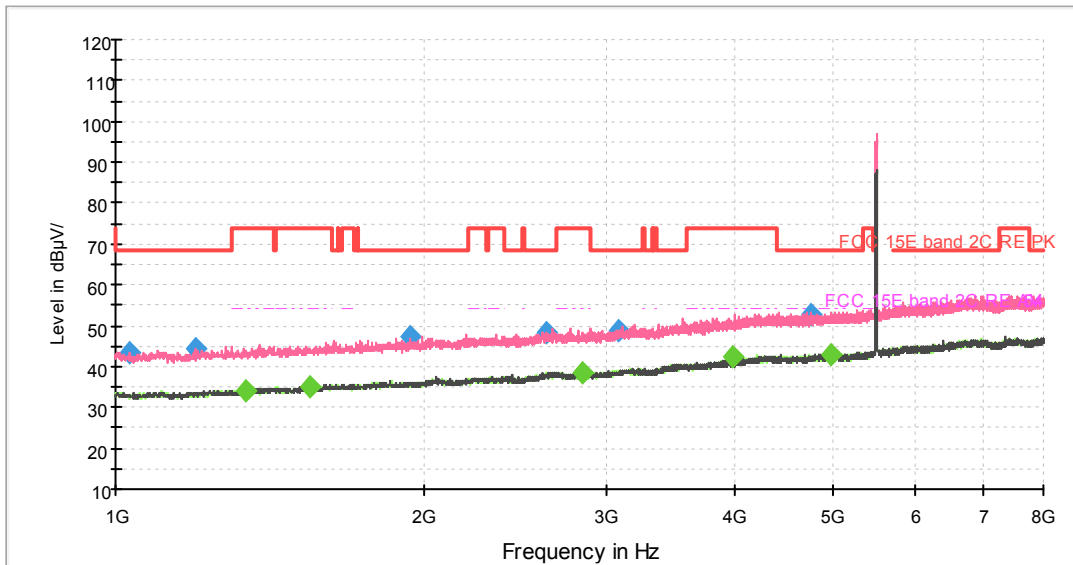

Note: The signal beyond the limit is carrier.
Radiates Emission from 1GHz to 8GHz

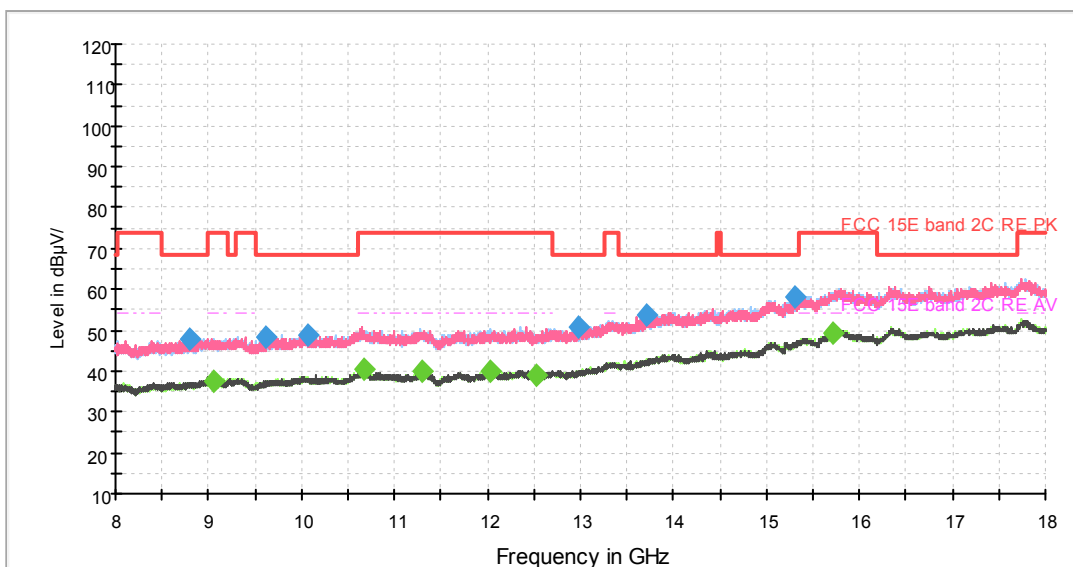

Radiates Emission from 8GHz to 18GHz

Frequency (MHz)	Peak (dBuV/m)	Height (cm)	Polarization	Azimuth (deg)	Correct Factor (dB)	Margin (dB)	Limit (dBuV/m)
1030.625000	43.6	100.0	V	140.0	-0.4	24.6	68.2
1194.250000	44.2	100.0	V	173.0	0.7	24.0	68.2
1937.125000	47.1	100.0	H	0.0	3.9	21.1	68.2
2631.000000	48.1	100.0	V	182.0	6.8	20.1	68.2
3083.375000	48.7	100.0	V	83.0	8.5	19.5	68.2



4752.000000	52.8	100.0	V	198.0	13.2	15.4	68.2
-------------	------	-------	---	-------	------	------	------

Remark: 1. Correction Factor = Antenna factor+ Insertion loss (cable loss + amplifier gain)

Frequency (MHz)	Average (dBuV/m)	Height (cm)	Polarization	Azimuth (deg)	Correct Factor (dB)	Margin (dB)	Limit (dBuV/m)
1341.250000	34.1	100.0	H	277.0	1.4	19.9	54.0
1546.000000	34.8	100.0	V	57.0	2.3	19.2	54.0
2842.750000	38.7	100.0	V	254.0	7.5	15.3	54.0
3992.500000	42.4	100.0	V	351.0	11.5	11.6	54.0
4979.500000	42.7	100.0	V	279.0	13.6	11.3	54.0
1341.250000	34.1	100.0	H	277.0	1.4	19.9	54.0

Remark: 1. Correction Factor = Antenna factor+ Insertion loss (cable loss + amplifier gain)



802.11n (HT20) CH116

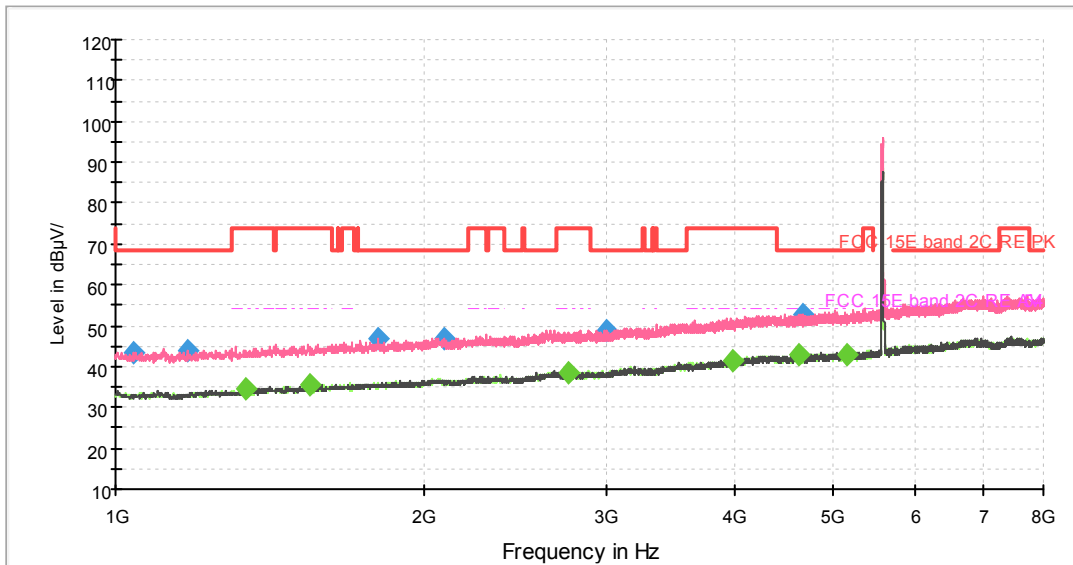

Note: The signal beyond the limit is carrier.
Radiates Emission from 1GHz to 8GHz

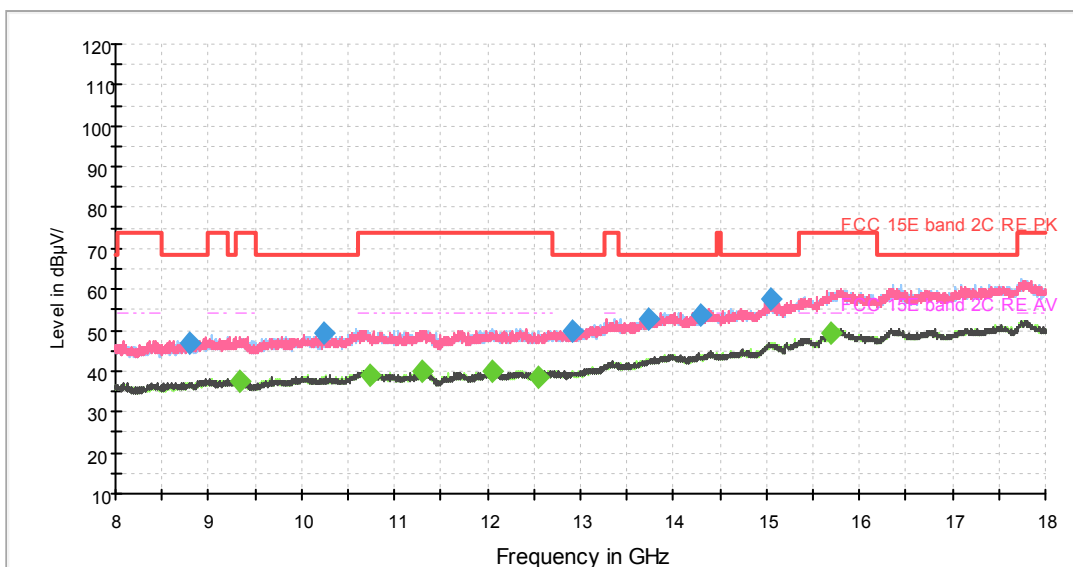

Radiates Emission from 8GHz to 18GHz

Frequency (MHz)	Peak (dBuV/m)	Height (cm)	Polarization	Azimuth (deg)	Correct Factor (dB)	Margin (dB)	Limit (dBuV/m)
1040.250000	43.3	100.0	V	90.0	-0.4	24.9	68.2
1174.125000	44.0	100.0	V	26.0	0.6	24.2	68.2
1800.625000	47.0	100.0	V	0.0	3.4	21.2	68.2
2090.250000	46.9	100.0	V	180.0	4.5	21.3	68.2
3003.750000	48.7	100.0	V	213.0	8.2	19.5	68.2



4667.125000	52.6	100.0	V	164.0	13.0	15.6	68.2
-------------	------	-------	---	-------	------	------	------

Remark: 1. Correction Factor = Antenna factor+ Insertion loss (cable loss + amplifier gain)

Frequency (MHz)	Average (dBuV/m)	Height (cm)	Polarization	Azimuth (deg)	Correct Factor (dB)	Margin (dB)	Limit (dBuV/m)
1339.500000	34.3	100.0	V	131.0	1.4	19.7	54.0
1544.250000	35.3	100.0	V	66.0	2.3	18.7	54.0
2764.875000	38.4	100.0	V	26.0	7.3	15.6	54.0
3994.250000	41.6	100.0	H	78.0	11.5	12.4	54.0
4619.875000	42.7	100.0	H	211.0	12.9	11.3	54.0
5158.000000	42.8	100.0	H	339.0	13.9	11.2	54.0

Remark: 1. Correction Factor = Antenna factor+ Insertion loss (cable loss + amplifier gain)



802.11n (HT20) CH140

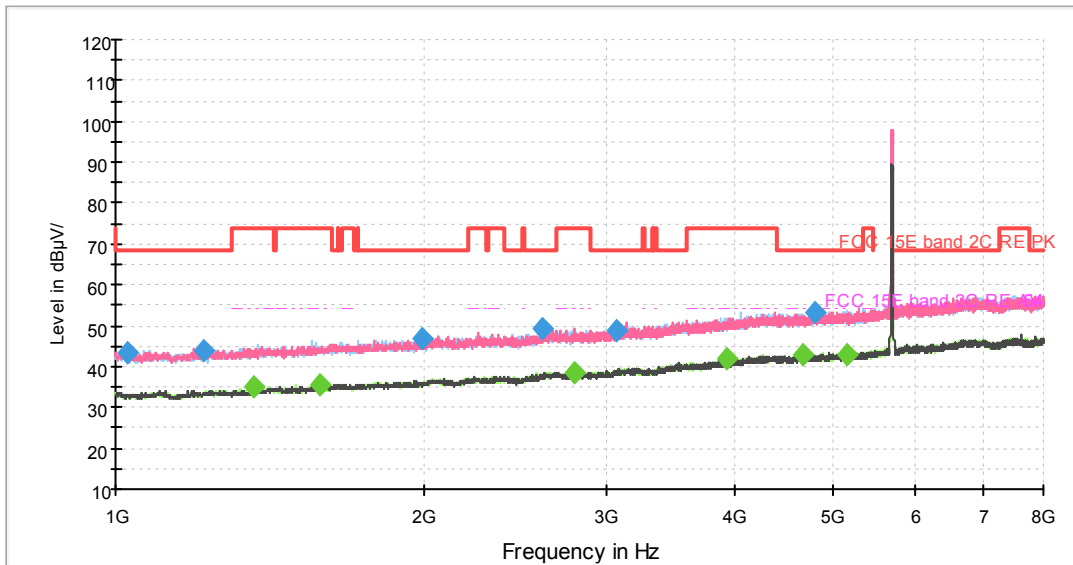

Note: The signal beyond the limit is carrier.
Radiates Emission from 1GHz to 8GHz

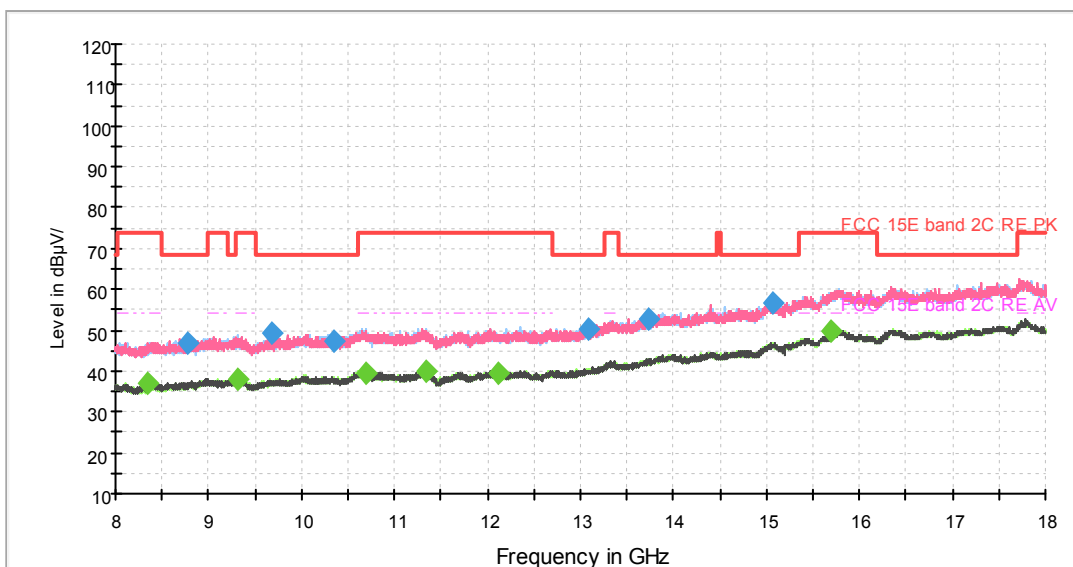

Radiates Emission from 8GHz to 18GHz

Frequency (MHz)	Peak (dBuV/m)	Height (cm)	Polarization	Azimuth (deg)	Correct Factor (dB)	Margin (dB)	Limit (dBuV/m)
1028.875000	43.3	100.0	V	0.0	-0.4	24.9	68.2
1216.125000	43.9	100.0	V	101.0	0.8	24.3	68.2
1984.375000	46.7	100.0	V	190.0	4.2	21.5	68.2
2597.750000	49.4	100.0	V	290.0	6.6	18.8	68.2
3067.625000	48.6	100.0	H	156.0	8.5	19.6	68.2



4787.000000	53.2	100.0	H	0.0	13.3	15.0	68.2
-------------	------	-------	---	-----	------	------	------

Remark: 1. Correction Factor = Antenna factor+ Insertion loss (cable loss + amplifier gain)

Frequency (MHz)	Average (dBuV/m)	Height (cm)	Polarization	Azimuth (deg)	Correct Factor (dB)	Margin (dB)	Limit (dBuV/m)
1365.750000	35.2	100.0	V	351.0	1.6	18.8	54.0
1581.000000	35.8	100.0	V	143.0	2.4	18.2	54.0
2792.000000	38.4	100.0	H	164.0	7.4	15.6	54.0
3927.750000	41.7	100.0	V	254.0	11.3	12.3	54.0
4656.625000	42.8	100.0	H	276.0	13.0	11.2	54.0
5156.250000	42.9	100.0	V	38.0	13.9	11.1	54.0

Remark: 1. Correction Factor = Antenna factor+ Insertion loss (cable loss + amplifier gain)



802.11n (HT20) CH149

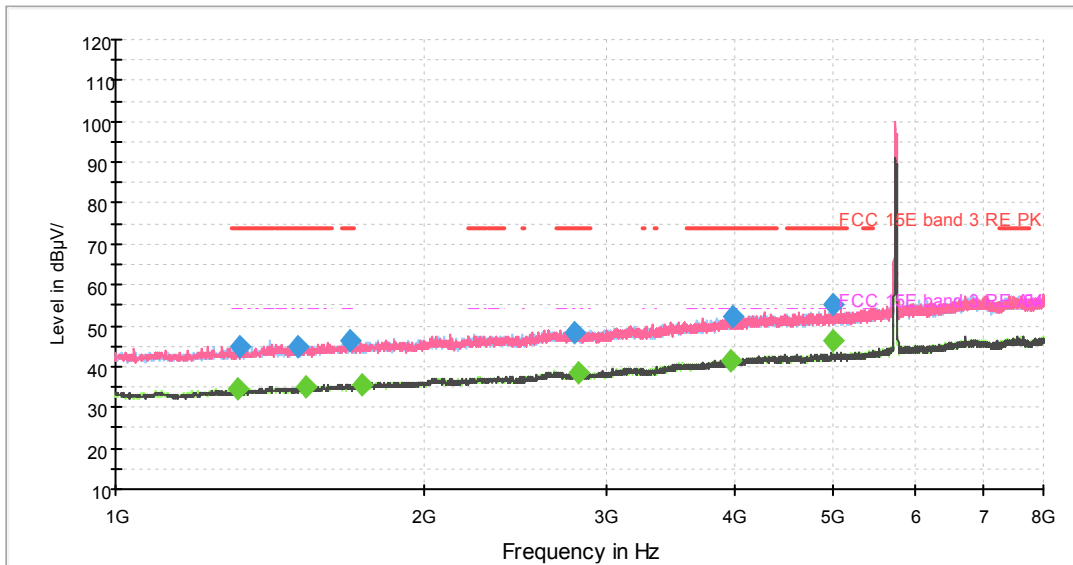

Note: The signal beyond the limit is carrier.
Radiates Emission from 1GHz to 8GHz

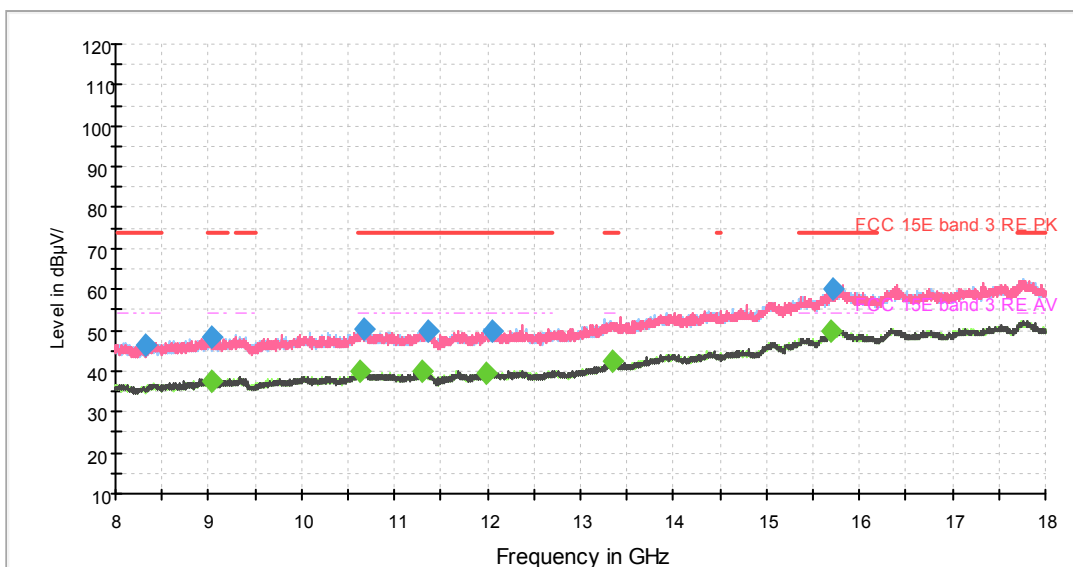

Radiates Emission from 8GHz to 18GHz

Frequency (MHz)	Peak (dBuV/m)	Height (cm)	Polarization	Azimuth (deg)	Correct Factor (dB)	Margin (dB)	Limit (dBuV/m)
1319.375000	44.8	100.0	V	51.0	1.3	29.2	74.0
1503.125000	45.1	100.0	H	204.0	2.2	28.9	74.0
1694.750000	46.3	100.0	V	203.0	3.0	27.7	74.0
2797.250000	48.5	100.0	V	35.0	7.4	25.5	74.0
3979.375000	52.0	100.0	V	0.0	11.5	22.0	74.0



4989.125000	55.1	100.0	H	59.0	13.6	18.9	74.0
-------------	------	-------	---	------	------	------	------

Remark: 1. Correction Factor = Antenna factor+ Insertion loss (cable loss + amplifier gain)

Frequency (MHz)	Average (dBuV/m)	Height (cm)	Polarization	Azimuth (deg)	Correct Factor (dB)	Margin (dB)	Limit (dBuV/m)
1315.875000	34.8	100.0	H	303.0	1.3	19.2	54.0
1533.750000	35.1	100.0	H	350.0	2.2	18.9	54.0
1735.000000	35.7	100.0	V	27.0	3.2	18.3	54.0
2826.125000	38.5	100.0	V	172.0	7.5	15.5	54.0
3977.625000	41.6	100.0	H	335.0	11.5	12.4	54.0
4989.125000	46.4	100.0	H	59.0	13.6	7.6	54.0

Remark: 1. Correction Factor = Antenna factor+ Insertion loss (cable loss + amplifier gain)



802.11n (HT20) CH157

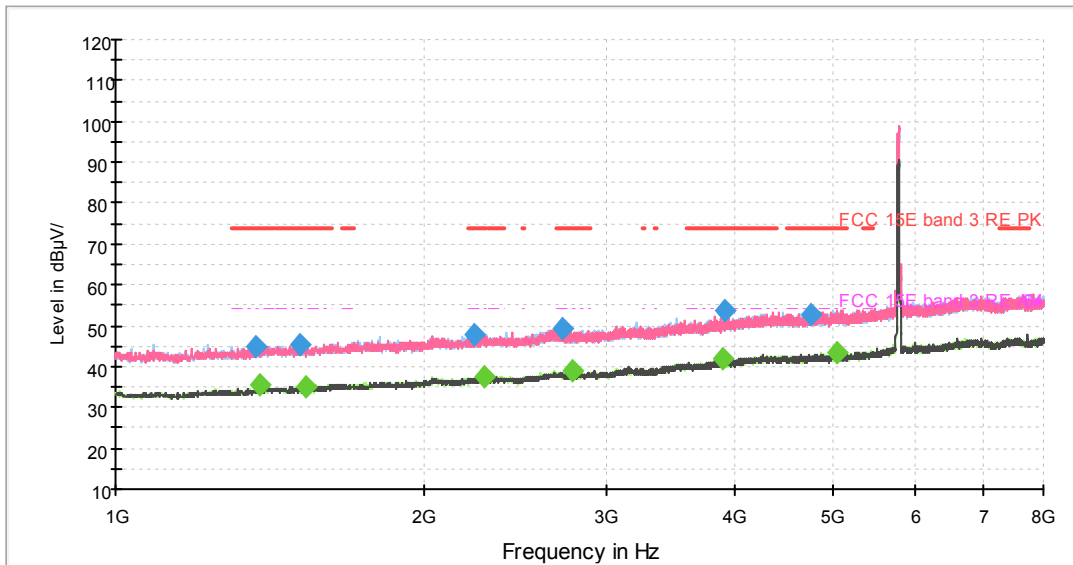

Note: The signal beyond the limit is carrier.
Radiates Emission from 1GHz to 8GHz

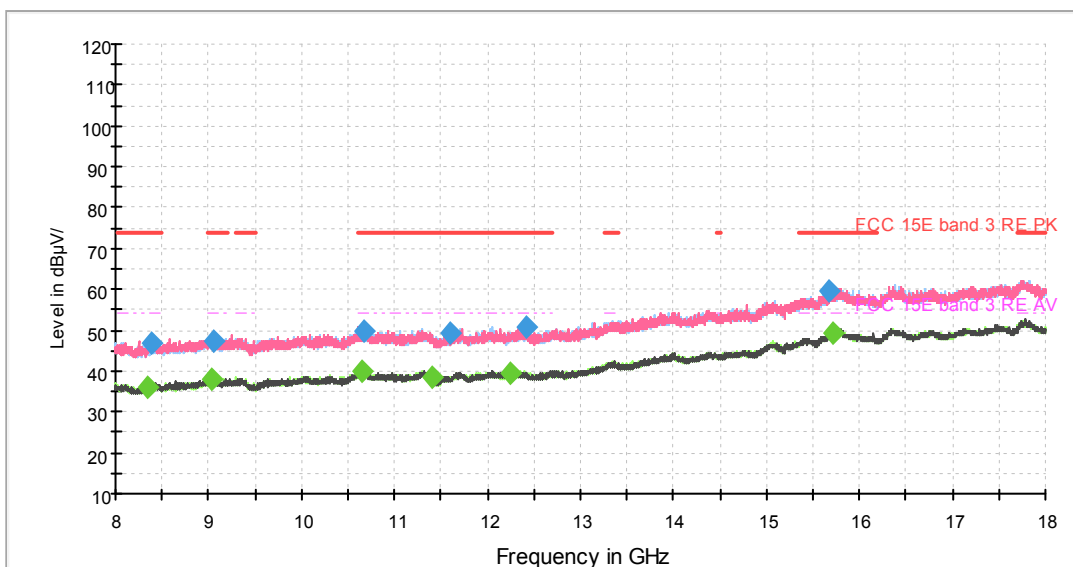

Radiates Emission from 8GHz to 18GHz

Frequency (MHz)	Peak (dBuV/m)	Height (cm)	Polarization	Azimuth (deg)	Correct Factor (dB)	Margin (dB)	Limit (dBuV/m)
1371.000000	44.6	100.0	V	76.0	1.6	29.4	74.0
1511.000000	45.3	100.0	H	4.0	2.2	28.7	74.0
2238.125000	47.6	100.0	V	70.0	5.1	26.4	74.0
2726.375000	49.1	100.0	H	124.0	7.1	24.9	74.0
3917.250000	53.8	100.0	V	203.0	11.2	20.2	74.0



4760.750000	52.6	100.0	V	311.0	13.2	21.4	74.0
-------------	------	-------	---	-------	------	------	------

Remark: 1. Correction Factor = Antenna factor+ Insertion loss (cable loss + amplifier gain)

Frequency (MHz)	Average (dBuV/m)	Height (cm)	Polarization	Azimuth (deg)	Correct Factor (dB)	Margin (dB)	Limit (dBuV/m)
1381.500000	35.3	100.0	H	330.0	1.7	18.7	54.0
1530.250000	34.9	100.0	V	29.0	2.2	19.1	54.0
2283.625000	37.6	100.0	V	359.0	5.4	16.4	54.0
2785.875000	38.9	100.0	H	347.0	7.3	15.1	54.0
3900.625000	41.7	100.0	V	115.0	11.1	12.3	54.0
5042.500000	43.3	100.0	V	348.0	13.7	10.7	54.0

Remark: 1. Correction Factor = Antenna factor+ Insertion loss (cable loss + amplifier gain)



802.11n (HT20) CH165

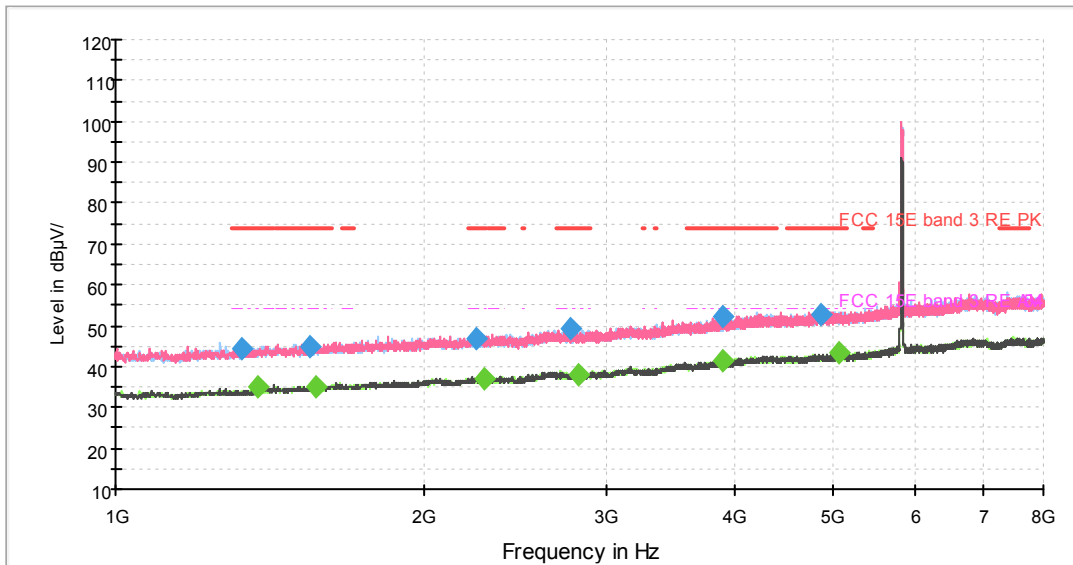

Note: The signal beyond the limit is carrier.
Radiates Emission from 1GHz to 8GHz

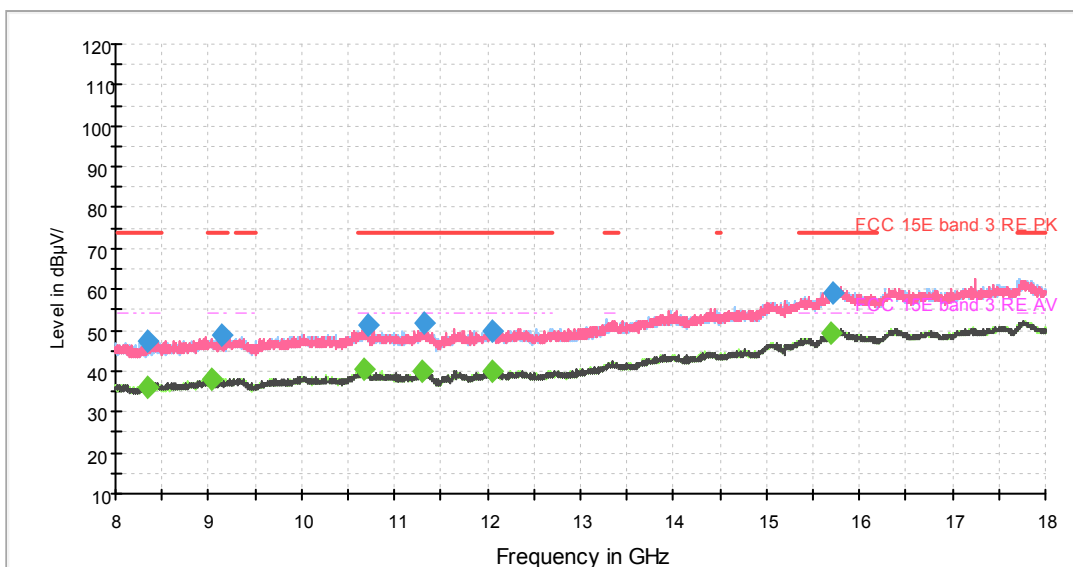

Radiates Emission from 8GHz to 18GHz

Frequency (MHz)	Peak (dBuV/m)	Height (cm)	Polarization	Azimuth (deg)	Correct Factor (dB)	Margin (dB)	Limit (dBuV/m)
1329.000000	44.3	100.0	V	0.0	1.3	29.7	74.0
1546.000000	44.7	100.0	H	262.0	2.3	29.3	74.0
2240.750000	46.9	100.0	V	0.0	5.1	27.1	74.0
2777.125000	49.1	100.0	V	88.0	7.3	24.9	74.0
3897.125000	52.0	100.0	V	63.0	11.1	22.0	74.0



4867.500000	53.0	100.0	V	96.0	13.4	21.0	74.0
-------------	------	-------	---	------	------	------	------

Remark: 1. Correction Factor = Antenna factor+ Insertion loss (cable loss + amplifier gain)

Frequency (MHz)	Average (dBuV/m)	Height (cm)	Polarization	Azimuth (deg)	Correct Factor (dB)	Margin (dB)	Limit (dBuV/m)
1376.250000	34.9	100.0	V	185.0	1.7	19.1	54.0
1566.125000	35.0	100.0	H	24.0	2.4	19.0	54.0
2284.500000	37.2	100.0	H	174.0	5.4	16.8	54.0
2820.875000	38.1	100.0	H	295.0	7.5	15.9	54.0
3902.375000	41.6	100.0	H	72.0	11.2	12.4	54.0
5058.250000	43.6	100.0	V	0.0	13.7	10.4	54.0

Remark: 1. Correction Factor = Antenna factor+ Insertion loss (cable loss + amplifier gain)



802.11n (HT40) CH38

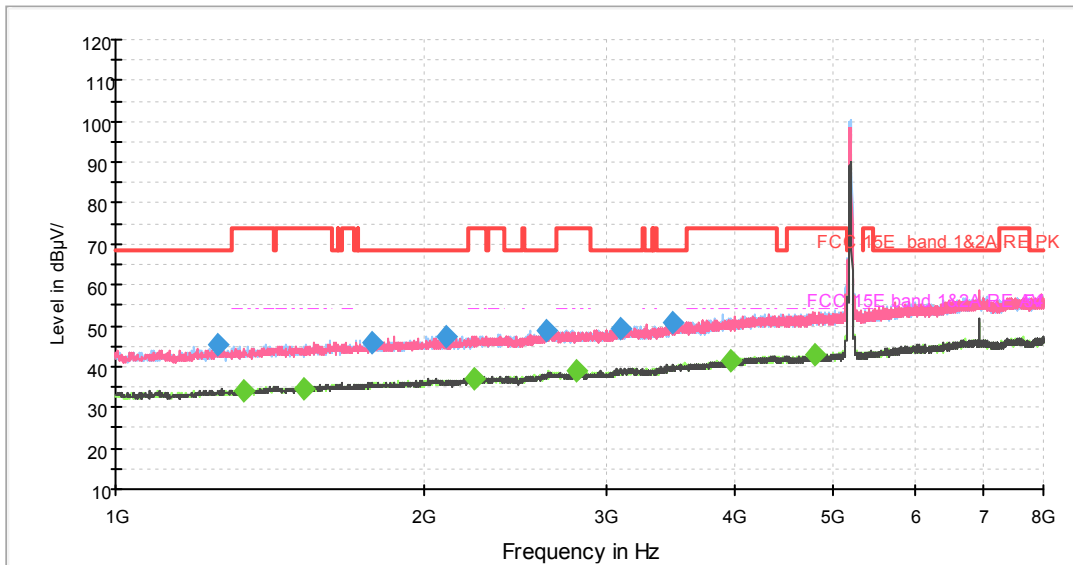

Note: The signal beyond the limit is carrier.
Radiates Emission from 1GHz to 8GHz

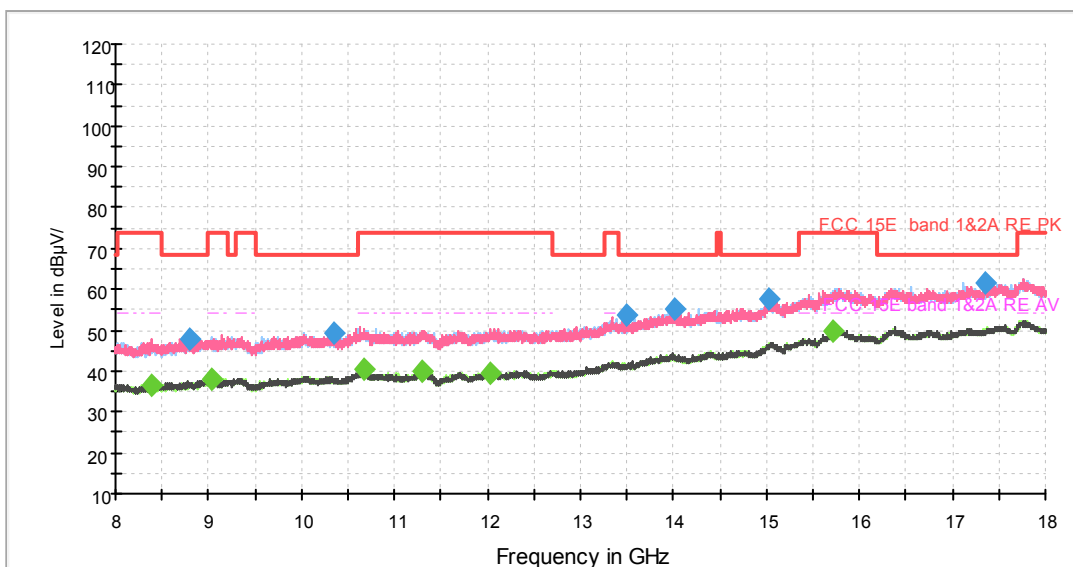

Radiates Emission from 8GHz to 18GHz

Frequency (MHz)	Peak (dBuV/m)	Height (cm)	Polarization	Azimuth (deg)	Correct Factor (dB)	Margin (dB)	Limit (dBuV/m)
1257.250000	45.3	100.0	H	104.0	1.0	22.9	68.2
1777.875000	45.8	100.0	H	212.0	3.3	22.4	68.2
2095.500000	47.3	100.0	V	321.0	4.5	20.9	68.2
2625.750000	48.7	100.0	H	58.0	6.8	19.5	68.2
3100.000000	49.4	100.0	V	0.0	8.6	18.8	68.2



3492.875000	50.7	100.0	V	86.0	9.8	17.5	68.2
-------------	------	-------	---	------	-----	------	------

Remark: 1. Correction Factor = Antenna factor+ Insertion loss (cable loss + amplifier gain)

Frequency (MHz)	Average (dBuV/m)	Height (cm)	Polarization	Azimuth (deg)	Correct Factor (dB)	Margin (dB)	Limit (dBuV/m)
1330.750000	34.1	100.0	V	119.0	1.4	19.9	54.0
1525.000000	34.7	100.0	H	165.0	2.2	19.3	54.0
2239.000000	37.0	100.0	V	14.0	5.1	17.0	54.0
2813.000000	38.9	100.0	H	348.0	7.4	15.1	54.0
3965.375000	41.4	100.0	V	161.0	11.4	12.6	54.0
4786.125000	42.7	100.0	H	197.0	13.3	11.3	54.0

Remark: 1. Correction Factor = Antenna factor+ Insertion loss (cable loss + amplifier gain)



802.11n (HT40) CH46

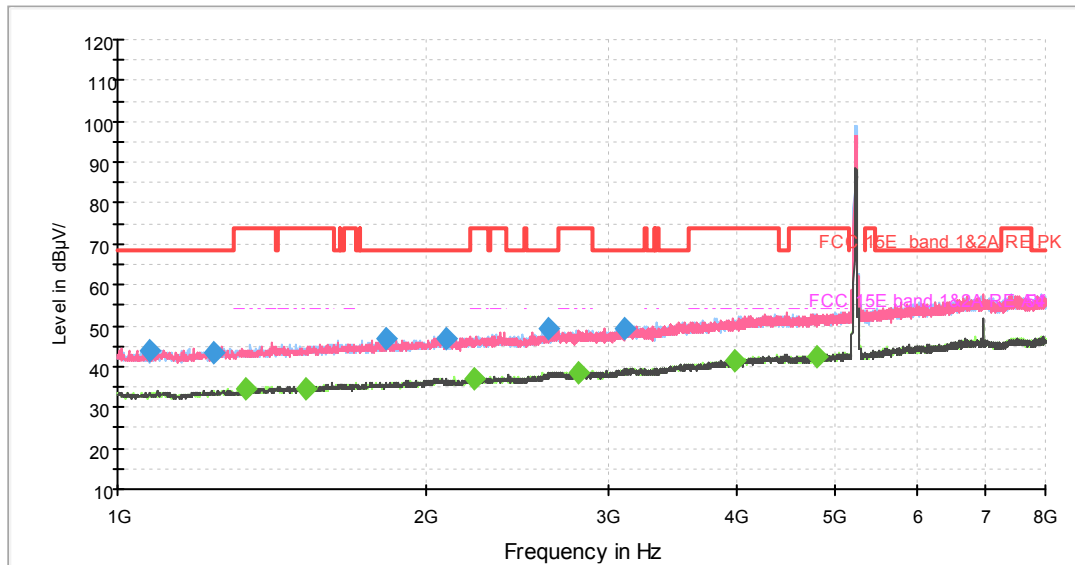

Note: The signal beyond the limit is carrier.
Radiates Emission from 1GHz to 8GHz

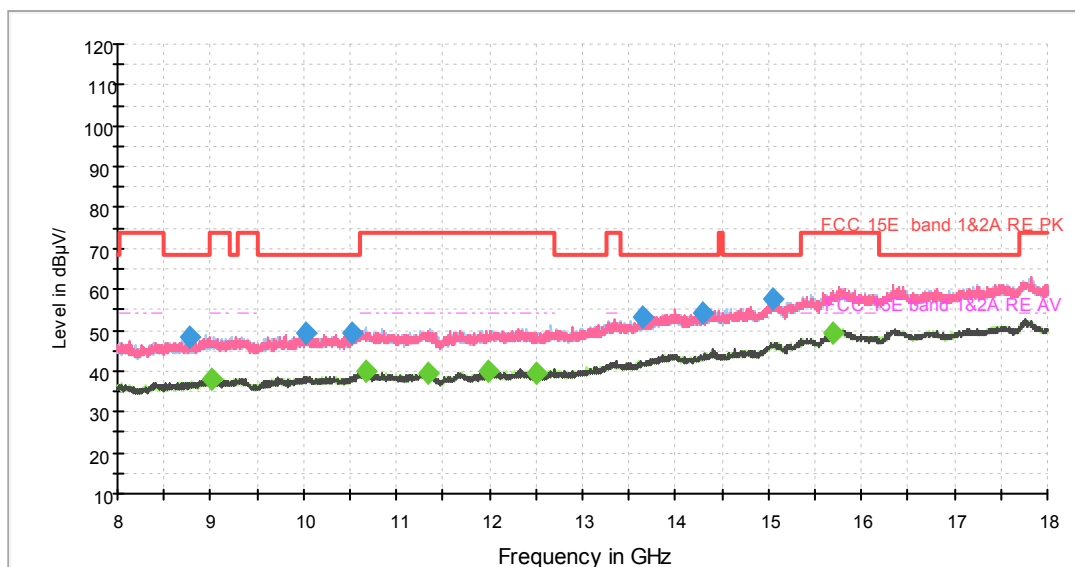

Radiates Emission from 8GHz to 18GHz

Frequency (MHz)	Peak (dBuV/m)	Height (cm)	Polarization	Azimuth (deg)	Correct Factor (dB)	Margin (dB)	Limit (dBuV/m)
1075.250000	44.0	100.0	V	111.0	-0.2	24.2	68.2
1240.625000	43.3	100.0	H	29.0	0.9	24.9	68.2
1826.875000	46.7	100.0	V	78.0	3.5	21.5	68.2
2086.750000	46.9	100.0	V	95.0	4.4	21.3	68.2
2624.875000	49.4	100.0	H	246.0	6.8	18.8	68.2



3112.250000	49.5	100.0	H	286.0	8.7	18.7	68.2
-------------	------	-------	---	-------	-----	------	------

Remark: 1. Correction Factor = Antenna factor+ Insertion loss (cable loss + amplifier gain)

Frequency (MHz)	Average (dBuV/m)	Height (cm)	Polarization	Azimuth (deg)	Correct Factor (dB)	Margin (dB)	Limit (dBuV/m)
1336.000000	34.4	100.0	H	316.0	1.4	19.6	54.0
1528.500000	34.6	100.0	H	191.0	2.2	19.4	54.0
2226.750000	37.0	100.0	H	138.0	5.1	17.0	54.0
2806.875000	38.4	100.0	V	78.0	7.4	15.6	54.0
3986.375000	41.4	100.0	V	139.0	11.5	12.6	54.0
4786.125000	42.2	100.0	H	255.0	13.3	11.8	54.0

Remark: 1. Correction Factor = Antenna factor+ Insertion loss (cable loss + amplifier gain)



802.11n (HT40) CH54

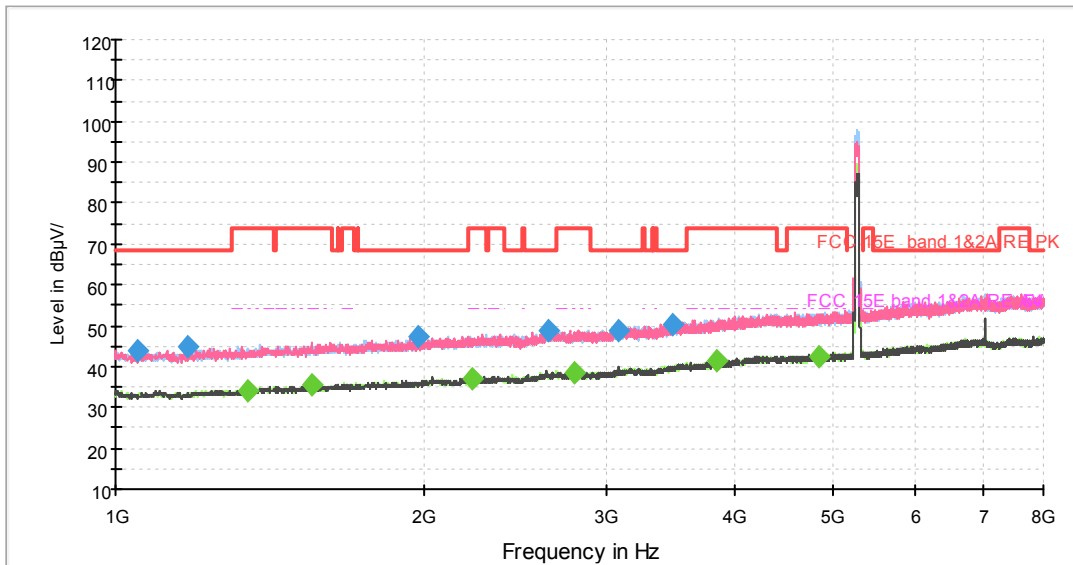

Note: The signal beyond the limit is carrier.
Radiates Emission from 1GHz to 8GHz

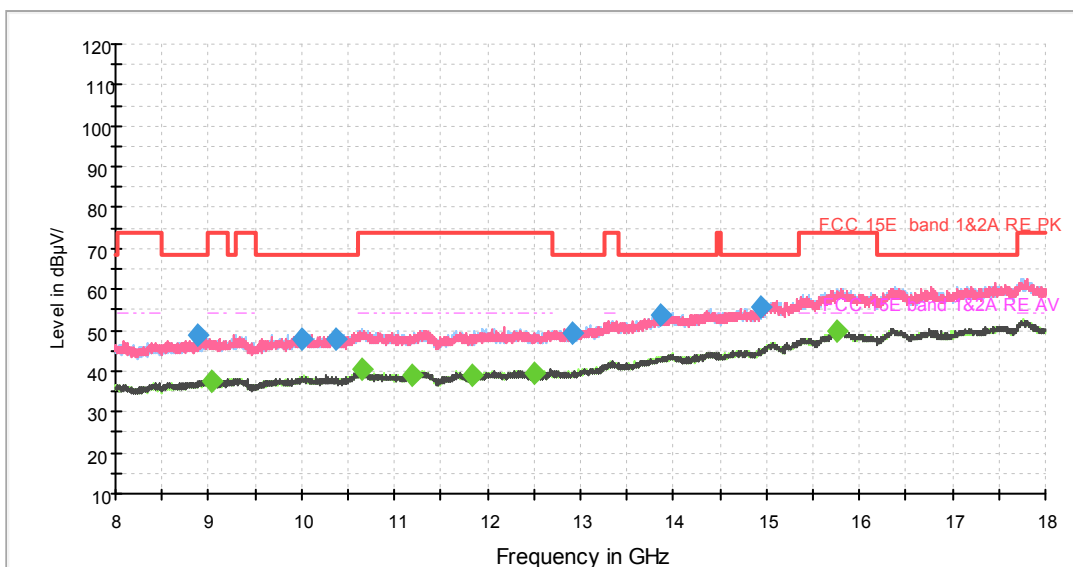

Radiates Emission from 8GHz to 18GHz

Frequency (MHz)	Peak (dBuV/m)	Height (cm)	Polarization	Azimuth (deg)	Correct Factor (dB)	Margin (dB)	Limit (dBuV/m)
1050.750000	44.0	100.0	H	131.0	-0.4	24.2	68.2
1175.000000	44.9	100.0	V	0.0	0.6	23.3	68.2
1973.875000	47.3	100.0	V	195.0	4.2	20.9	68.2
2638.000000	48.6	100.0	V	0.0	6.8	19.6	68.2
3092.125000	48.6	100.0	V	187.0	8.6	19.6	68.2



3492.875000	50.4	100.0	V	178.0	9.8	17.8	68.2
-------------	------	-------	---	-------	-----	------	------

Remark: 1. Correction Factor = Antenna factor+ Insertion loss (cable loss + amplifier gain)

Frequency (MHz)	Average (dBuV/m)	Height (cm)	Polarization	Azimuth (deg)	Correct Factor (dB)	Margin (dB)	Limit (dBuV/m)
1342.125000	34.1	100.0	V	112.0	1.4	19.9	54.0
1552.125000	35.4	100.0	V	305.0	2.3	18.6	54.0
2226.750000	37.1	100.0	H	339.0	5.1	16.9	54.0
2801.625000	38.3	100.0	H	0.0	7.4	15.7	54.0
3843.750000	41.5	100.0	V	30.0	10.9	12.5	54.0
4836.875000	42.4	100.0	H	331.0	13.4	11.6	54.0

Remark: 1. Correction Factor = Antenna factor+ Insertion loss (cable loss + amplifier gain)



802.11n (HT40) CH62

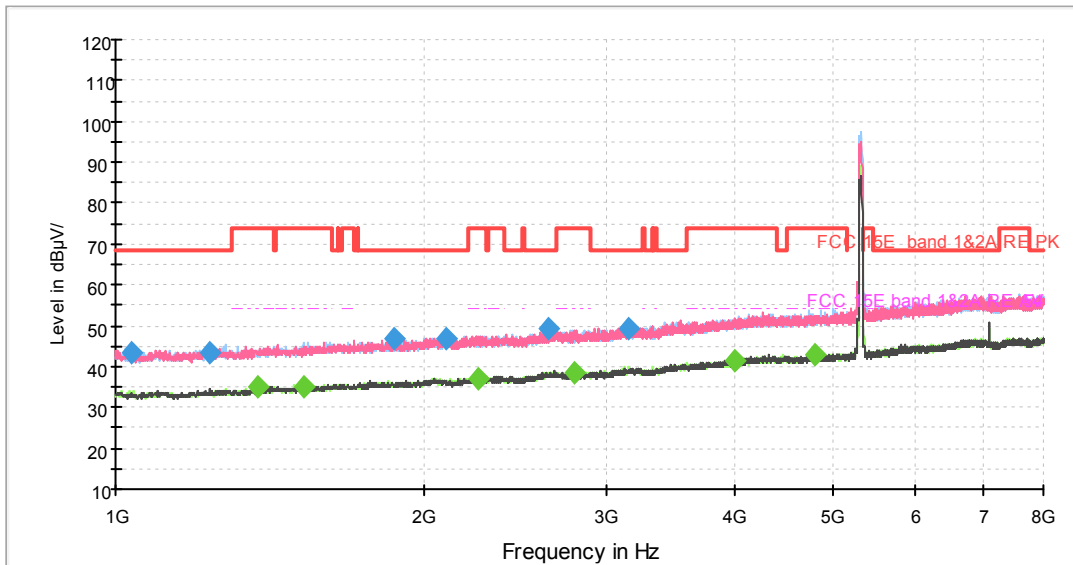

Note: The signal beyond the limit is carrier.
Radiates Emission from 1GHz to 8GHz

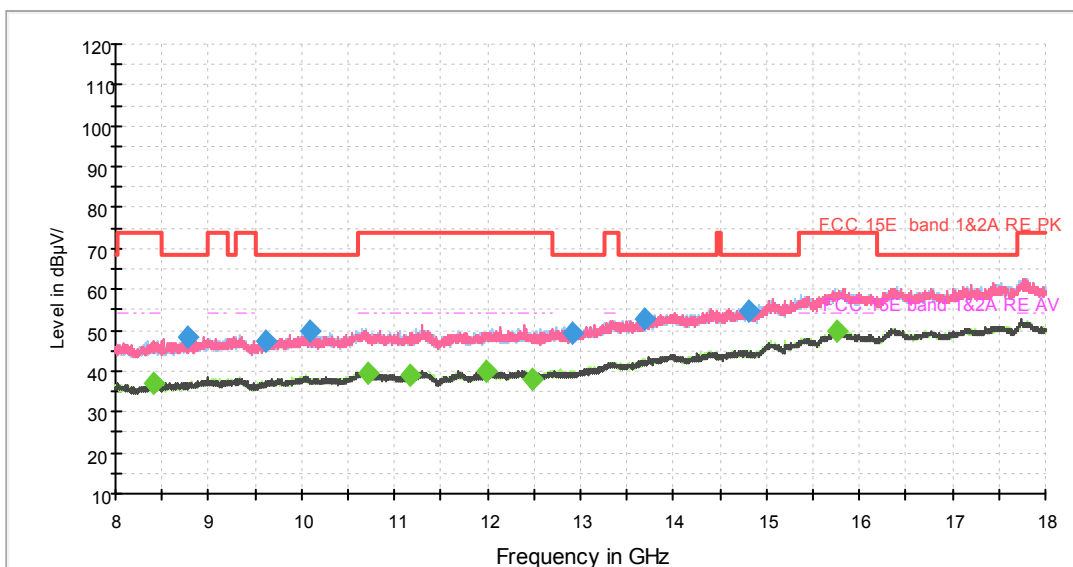

Radiates Emission from 8GHz to 18GHz

Frequency (MHz)	Peak (dBuV/m)	Height (cm)	Polarization	Azimuth (deg)	Correct Factor (dB)	Margin (dB)	Limit (dBuV/m)
1035.000000	43.4	100.0	V	86.0	-0.4	24.8	68.2
1234.500000	43.4	100.0	H	289.0	0.9	24.8	68.2
1862.750000	46.8	100.0	H	206.0	3.6	21.4	68.2
2101.625000	46.6	100.0	V	111.0	4.5	21.6	68.2
2644.125000	49.1	100.0	H	273.0	6.9	19.1	68.2



3156.000000	49.1	100.0	H	306.0	8.8	19.1	68.2
-------------	------	-------	---	-------	-----	------	------

Remark: 1. Correction Factor = Antenna factor+ Insertion loss (cable loss + amplifier gain)

Frequency (MHz)	Average (dBuV/m)	Height (cm)	Polarization	Azimuth (deg)	Correct Factor (dB)	Margin (dB)	Limit (dBuV/m)
1376.250000	35.1	100.0	V	61.0	1.7	18.9	54.0
1525.000000	35.1	100.0	H	281.0	2.2	18.9	54.0
2252.125000	37.2	100.0	V	192.0	5.2	16.8	54.0
2793.750000	38.4	100.0	H	273.0	7.4	15.6	54.0
3998.625000	41.6	100.0	V	273.0	11.6	12.4	54.0
4793.125000	42.8	100.0	V	332.0	13.3	11.2	54.0

Remark: 1. Correction Factor = Antenna factor+ Insertion loss (cable loss + amplifier gain)



802.11n (HT40) CH102

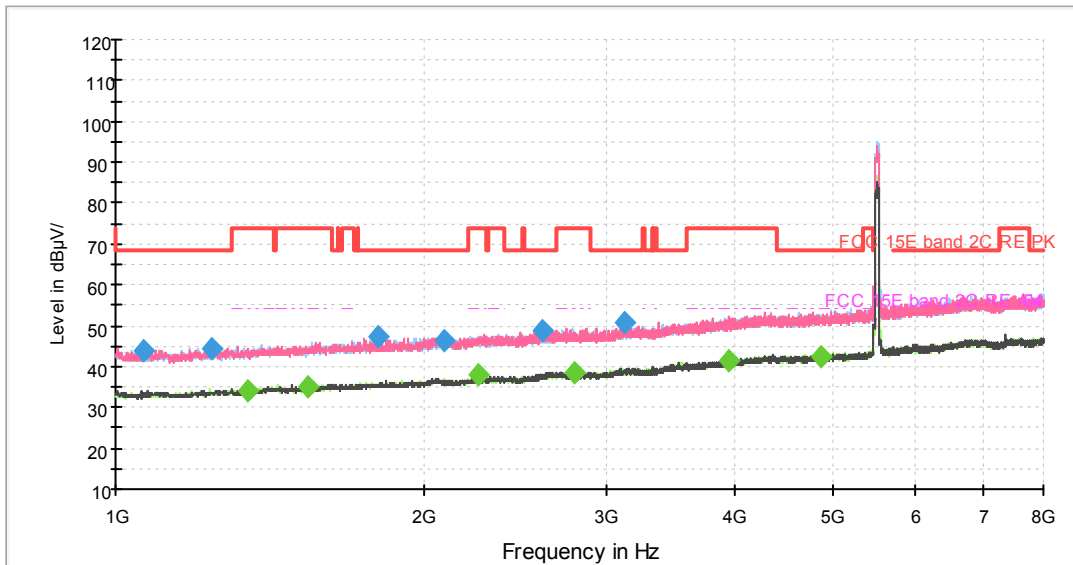

Note: The signal beyond the limit is carrier.
Radiates Emission from 1GHz to 8GHz

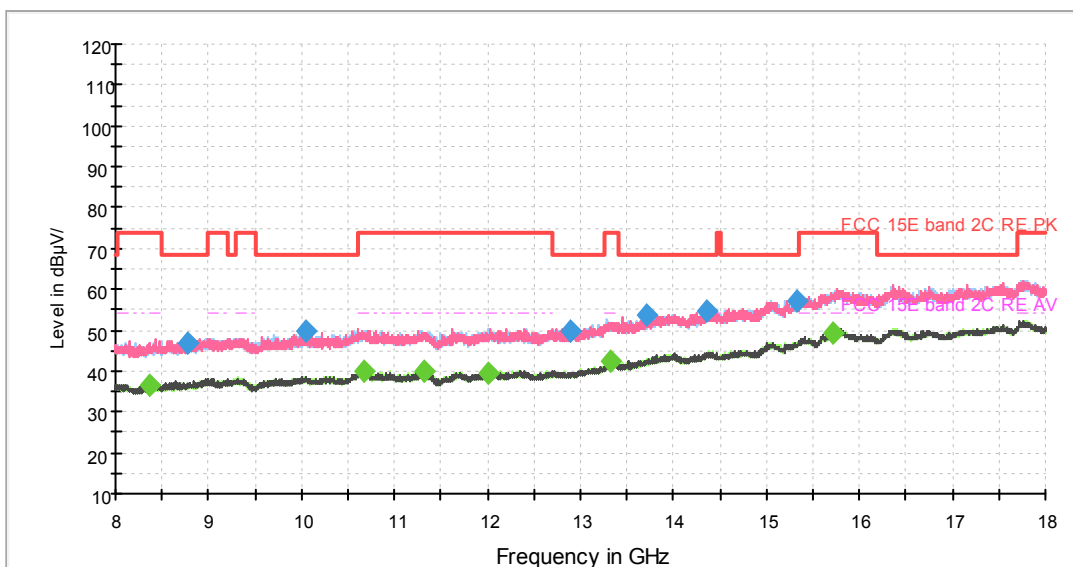

Radiates Emission from 8GHz to 18GHz

Frequency (MHz)	Peak (dBuV/m)	Height (cm)	Polarization	Azimuth (deg)	Correct Factor (dB)	Margin (dB)	Limit (dBuV/m)
1063.000000	44.0	100.0	V	238.0	-0.3	24.2	68.2
1243.250000	44.2	100.0	V	0.0	0.9	24.0	68.2
1801.500000	47.1	100.0	V	52.0	3.4	21.1	68.2
2092.875000	46.3	100.0	H	230.0	4.5	21.9	68.2
2597.750000	49.0	100.0	V	280.0	6.6	19.2	68.2



3132.375000	50.6	100.0	H	222.0	8.7	17.6	68.2
-------------	------	-------	---	-------	-----	------	------

Remark: 1. Correction Factor = Antenna factor+ Insertion loss (cable loss + amplifier gain)

Frequency (MHz)	Average (dBuV/m)	Height (cm)	Polarization	Azimuth (deg)	Correct Factor (dB)	Margin (dB)	Limit (dBuV/m)
1344.750000	34.1	100.0	V	224.0	1.4	19.9	54.0
1539.875000	35.2	100.0	V	85.0	2.2	18.8	54.0
2250.375000	37.8	100.0	V	52.0	5.2	16.2	54.0
2801.625000	38.3	100.0	H	166.0	7.4	15.7	54.0
3961.000000	41.4	100.0	H	352.0	11.4	12.6	54.0
4859.625000	42.2	100.0	H	197.0	13.4	11.8	54.0

Remark: 1. Correction Factor = Antenna factor+ Insertion loss (cable loss + amplifier gain)



802.11n (HT40) CH118

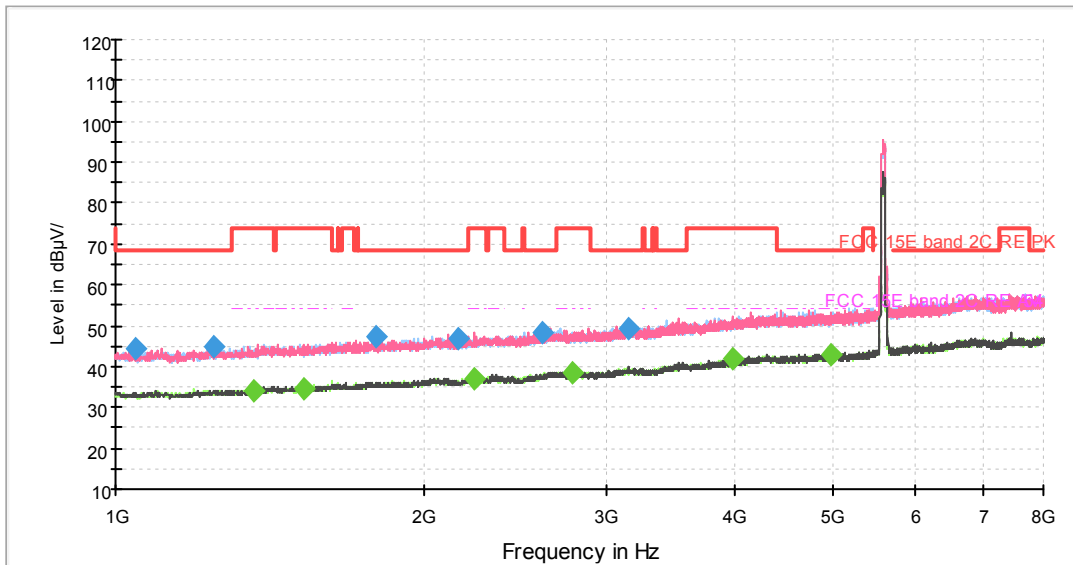

Note: The signal beyond the limit is carrier.
Radiates Emission from 1GHz to 8GHz

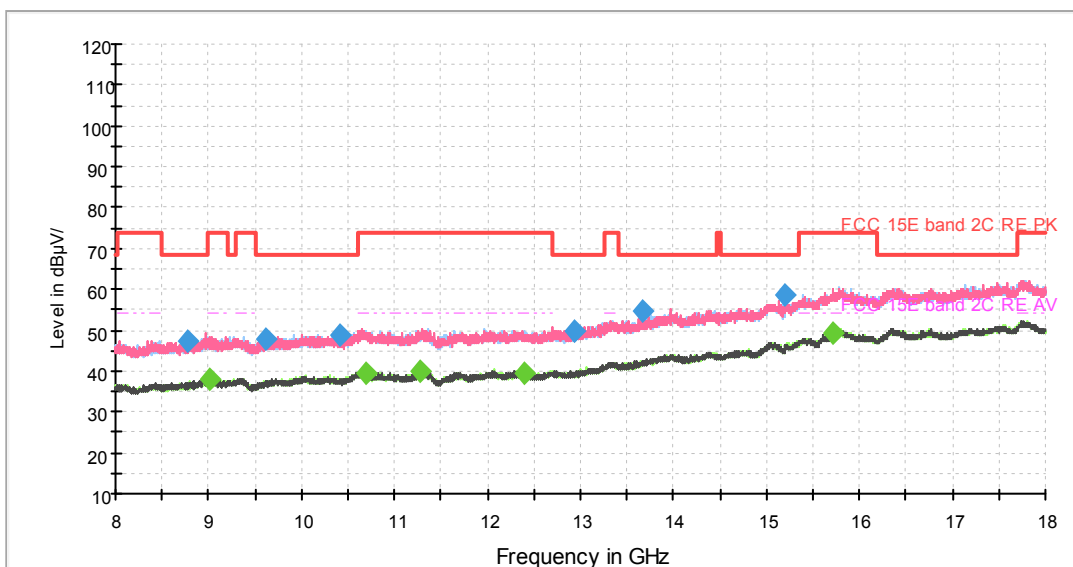

Radiates Emission from 8GHz to 18GHz

Frequency (MHz)	Peak (dBuV/m)	Height (cm)	Polarization	Azimuth (deg)	Correct Factor (dB)	Margin (dB)	Limit (dBuV/m)
1046.375000	44.5	100.0	H	332.0	-0.4	23.7	68.2
1244.125000	45.0	100.0	V	168.0	0.9	23.2	68.2
1794.500000	47.4	100.0	V	27.0	3.4	20.8	68.2
2153.250000	47.0	100.0	V	94.0	4.7	21.2	68.2
2603.875000	48.2	100.0	H	278.0	6.6	20.0	68.2