



RF TEST REPORT

Applicant Xiaomi Communications Co., Ltd.
FCC ID 2AFZZ3QNY
Product Mobile Phone
Brand Redmi
Model 220333QNY
Report No. R2111A1060-R6
Issue Date January 25, 2022

TA Technology (Shanghai) Co., Ltd. tested the above equipment in accordance with the requirements in **FCC CFR47 Part 15E (2020)**. The test results show that the equipment tested is capable of demonstrating compliance with the requirements as documented in this report.

Prepared by: Peng Tao

Approved by: Kai Xu

TA Technology (Shanghai) Co., Ltd.

No.145, Jintang Rd, Tangzhen Industry Park, Pudong Shanghai, China

TEL: +86-021-50791141/2/3

FAX: +86-021-50791141/2/3-8000



TABLE OF CONTENT

1. Test Laboratory	4
1.1. Notes of the test report.....	4
1.2. Test facility	4
1.3. Testing Location	4
2. General Description of Equipment under Test.....	5
2.1. Applicant and Manufacturer Information.....	5
2.2. General information.....	5
3. Applied Standards	6
4. Test Configuration	7
5. Test Case Results	10
5.1. Occupied Bandwidth	10
5.2. Average Power Output.....	29
5.3. Frequency Stability.....	37
5.4. Power Spectral Density.....	41
5.5. Unwanted Emission	58
5.6. Conducted Emission	157
6. Main Test Instruments.....	160
ANNEX A: The EUT Appearance	161
ANNEX B: Test Setup Photos	162

Summary of measurement results

Number	Test Case	Clause in FCC rules	Verdict
1	Average output power	15.407(a)	PASS
2	Occupied bandwidth	15.407(e)	PASS
3	Frequency stability	15.407(g)	PASS
4	Power spectral density	15.407(a)	PASS
5	Unwanted Emissions	15.407(b)	PASS
6	Conducted Emissions	15.207	PASS

Date of Testing: December 29, 2021 ~ January 5, 2022
Date of Sample Received: December 27, 2021

Note: PASS: The EUT complies with the essential requirements in the standard.
FAIL: The EUT does not comply with the essential requirements in the standard.
All indications of Pass/Fail in this report are opinions expressed by TA Technology (Shanghai) Co., Ltd. based on interpretations and/or observations of test results. Measurement Uncertainties were not taken into account and are published for informational purposes only.



1. Test Laboratory

1.1. Notes of the test report

This report shall not be reproduced in full or partial, without the written approval of **TA technology (shanghai) co., Ltd.** The results documented in this report apply only to the tested sample, under the conditions and modes of operation as described herein. Measurement Uncertainties were not taken into account and are published for informational purposes only. This report is written to support regulatory compliance of the applicable standards stated above.

1.2. Test facility

FCC (Designation number: CN1179, Test Firm Registration Number: 446626)

TA Technology (Shanghai) Co., Ltd. has been listed on the US Federal Communications Commission list of test facilities recognized to perform electromagnetic emissions measurements.

A2LA (Certificate Number: 3857.01)

TA Technology (Shanghai) Co., Ltd. has been listed by American Association for Laboratory Accreditation to perform electromagnetic emission measurement.

1.3. Testing Location

Company: TA Technology (Shanghai) Co., Ltd.
Address: No.145, Jintang Rd, Tangzhen Industry Park, Pudong
City: Shanghai
Post code: 201201
Country: P. R. China
Contact: Xu Kai
Telephone: +86-021-50791141/2/3
Fax: +86-021-50791141/2/3-8000
Website: <http://www.ta-shanghai.com>
E-mail: xukai@ta-shanghai.com

2. General Description of Equipment under Test

2.1. Applicant and Manufacturer Information

Applicant	Xiaomi Communications Co., Ltd.
Applicant address	#019, 9th Floor, Building 6, 33 Xi'erqi Middle Road, Haidian District, Beijing, China, 100085
Manufacturer	Xiaomi Communications Co., Ltd.
Manufacturer address	#019, 9th Floor, Building 6, 33 Xi'erqi Middle Road, Haidian District, Beijing, China, 100085

2.2. General information

EUT Description		
Model	220333QNY	
IMEI	IMEI 1: 862390060029800 IMEI 2: 862390060029818	
Hardware Version	P1.1	
Software Version	MIUI13	
Antenna Type	Fixed Internal Antenna	
Antenna Gain	5150MHz-5250MHz	-0.94dBi
	5250MHz -5350MHz	-0.88dBi
	5470MHz-5725MHz	-0.60dBi
	5725MHz -5850MHz	-0.66dBi
Operating Frequency Range(s)	U-NII-1: 5150MHz-5250MHz U-NII-2A: 5250MHz-5350MHz U-NII-2C: 5470MHz-5725MHz U-NII-3: 5725MHz -5850MHz	
Modulation Type	802.11a/n (HT20/HT40) : OFDM 802.11ac (VHT20/VHT40/VHT80): OFDM	
Max. Conducted Power	14.60dBm	
Testing temperature range:	-20 ° C to 50° C	
Operating temperature range:	0 ° C to 40° C	
Operating voltage range:	3.6V to 4.2V	
State DC voltage:	3.87V	
<p>Note: 1. The EUT is sent from the applicant to TA and the information of the EUT is declared by the applicant.</p> <p>2. This device support automatically discontinue transmission, while the device is not transmitting any information, the device can automatically discontinue transmission and become standby mode for power saving. The device can detect the controlling signal of ACK message transmitting from remote device and verify whether it shall resend or discontinue transmission.</p>		



3. Applied Standards

According to the specifications of the manufacturer, it must comply with the requirements of the following standards:

Test standards:

FCC CFR47 Part 15E (2020) Unlicensed National Information Infrastructure Devices

ANSI C63.10 (2013)

Reference standard:

KDB 789033 D02 General UNII Test Procedures New Rules v02r01

4. Test Configuration

Test Mode

The EUT has been associated with peripherals and configuration operated in a manner tended to maximize its emission characteristics in a typical application.

The radiated emission was measured in the following position: EUT stand-up position (Z axis), lie-down position (X, Y axis). The worst emission was found in stand-up position (Z axis) and the worst case was recorded.

In order to find the worst case condition, Pre-tests are needed at the presence of different data rate. Preliminary tests have been done on all the configuration for confirming worst case. Data rate below means worst-case rate of each test item.

Worst-case data rates are shown as following table.

Mode	Data Rate
802.11a	6 Mbps
802.11n HT20	MCS0
802.11n HT40	MCS0
802.11ac VHT20	MCS0
802.11ac VHT40	MCS0
802.11ac VHT80	MCS0



Wireless Technology and Frequency Range

Wireless Technology		Bandwidth	Channel	Frequency
Wi-Fi	U-NII-1	20 MHz	36	5180MHz
			40	5200MHz
			44	5220MHz
			48	5240MHz
		40 MHz	38	5190MHz
			46	5230MHz
	80 MHz	42	5210MHz	
	U-NII-2A	20 MHz	52	5260MHz
			56	5280MHz
			60	5300MHz
			64	5320MHz
		40 MHz	54	5270MHz
			62	5310MHz
	80 MHz	58	5290MHz	
	U-NII-2C	20 MHz	100	5500MHz
			104	5520MHz
			108	5540MHz
			112	5560MHz
			116	5580MHz
			120	5600MHz
			124	5620MHz
			128	5640MHz
			132	5660MHz
			136	5680MHz
			140	5700MHz
			144	5720MHz
		40 MHz	102	5510MHz
			110	5550MHz
			118	5590MHz
			126	5630MHz
134			5670MHz	
142			5710MHz	
80 MHz	106	5530MHz		
	122	5610MHz		
	138	5690MHz		
U-NII-3	20 MHz	149	5745MHz	
		153	5765MHz	
		157	5785MHz	



			161	5805MHz
			165	5825MHz
		40 MHz	151	5755MHz
			159	5795MHz
		80 MHz	155	5775MHz
Does this device support TPC Function? <input type="checkbox"/> Yes <input checked="" type="checkbox"/> No				
Does this device support TDWR Band? <input checked="" type="checkbox"/> Yes <input type="checkbox"/> No				

5. Test Case Results

5.1. Occupied Bandwidth

Ambient condition

Temperature	Relative humidity	Pressure
23°C ~25°C	45%~50%	101.5kPa

Method of Measurement

The EUT was connected to the spectrum analyzer through an external attenuator (20dB) and a known loss cable.

For U-NII-1/U-NII-2A/U-NII-2C, set RBW \approx 1% OCB kHz, VBW \geq 3 \times RBW, measure the maximum width of the emission that is constrained by the frequencies associated with the two outermost amplitude points (upper and lower frequencies) that are attenuated by 26 dB relative to the maximum level measured in the fundamental emission.

For U-NII-3, Set RBW = 100 kHz, VBW \geq 3 \times RBW, measure the maximum width of the emission that is constrained by the frequencies associated with the two outermost amplitude points (upper and lower frequencies) that are attenuated by 6 dB relative to the maximum level measured in the fundamental emission.

Note: The automatic bandwidth measurement capability of a spectrum analyzer or EMI receiver may be employed if it implements the functionality described above.

Use the 99 % power bandwidth function of the instrument

Test Setup

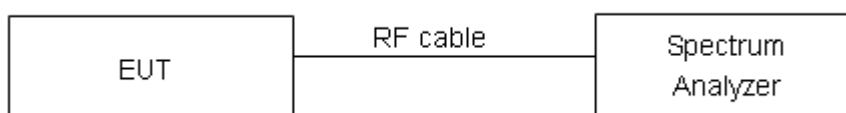

Limits

Rule FCC Part §15.407(e)

Within the 5.725-5.85 GHz band, the minimum 6 dB bandwidth of U-NII devices shall be at least 500 kHz.

Measurement Uncertainty

The assessed measurement uncertainty to ensure 95% confidence level for the normal distribution is with the coverage factor $k = 2$, $U = 936$ Hz.

**Test Results:****U-NII-1**

Mode	Carrier frequency (MHz)	99% bandwidth (MHz)	Minimum 26 dB bandwidth (MHz)	Conclusion
802.11a	36/5180	16.580	23.54	PASS
	40/5200	16.570	22.05	PASS
	48/5240	16.561	21.37	PASS
802.11n HT20	36/5180	17.710	22.52	PASS
	40/5200	17.739	23.13	PASS
	48/5240	17.705	22.68	PASS
802.11n HT40	38/5190	36.174	40.88	PASS
	46/5230	36.207	40.91	PASS
802.11ac VHT20	36/5180	17.729	21.94	PASS
	40/5200	17.709	22.96	PASS
	48/5240	17.698	21.99	PASS
802.11ac VHT40	38/5190	36.157	41.12	PASS
	46/5230	36.211	40.54	PASS
802.11ac VHT80	42/5210	76.619	82.36	PASS

U-NII-2A

Mode	Carrier frequency (MHz)	99% bandwidth (MHz)	Minimum 26 dB bandwidth (MHz)	Conclusion
802.11a	52/5260	16.549	23.84	PASS
	60/5300	16.549	21.44	PASS
	64/5320	16.544	22.37	PASS
802.11n HT20	52/5260	17.699	22.69	PASS
	60/5300	17.715	23.18	PASS
	64/5320	17.717	22.13	PASS
802.11n HT40	54/5270	36.190	41.11	PASS
	62/5310	36.218	40.62	PASS
802.11ac VHT20	52/5260	17.683	21.78	PASS
	60/5300	17.711	23.81	PASS
	64/5320	17.716	21.75	PASS
802.11ac VHT40	54/5270	36.232	41.19	PASS
	62/5310	36.197	41.72	PASS
802.11ac VHT80	58/5290	76.674	82.74	PASS



U-NII-2C

Mode	Carrier frequency (MHz)	99% bandwidth (MHz)	Minimum 26 dB bandwidth (MHz)	Conclusion
802.11a	100/5500	16.527	22.26	PASS
	120/5600	16.525	22.92	PASS
	140/5700	16.571	22.13	PASS
	144/5720	16.524	22.01	PASS
802.11n HT20	100/5500	17.728	23.12	PASS
	120/5600	17.676	22.22	PASS
	140/5700	17.667	21.72	PASS
	144/5720	17.696	22.57	PASS
802.11n HT40	102/5510	36.206	40.87	PASS
	118/5590	36.179	40.96	PASS
	134/5670	36.192	41.03	PASS
	142/5710	36.200	41.45	PASS
802.11ac VHT20	100/5500	17.708	21.92	PASS
	120/5600	17.708	23.24	PASS
	140/5700	17.725	23.54	PASS
	144/5720	17.708	23.12	PASS
802.11ac VHT40	102/5510	36.210	40.13	PASS
	118/5590	36.214	41.04	PASS
	134/5670	36.175	40.96	PASS
	142/5710	36.194	40.62	PASS
802.11ac VHT80	122/5610	75.616	83.86	PASS
	138/5690	75.633	82.06	PASS



U-NII-3

Mode	Carrier frequency (MHz)	99% bandwidth (MHz)	Minimum 6 dB bandwidth (MHz)	Limit (kHz)	Conclusion
802.11a	149/5745	16.546	15.15	500	PASS
	157/5785	16.528	15.02	500	PASS
	165/5825	16.518	15.12	500	PASS
802.11n HT20	149/5745	17.701	16.16	500	PASS
	157/5785	17.737	16.53	500	PASS
	165/5825	17.718	17.26	500	PASS
802.11n HT40	151/5755	36.212	35.47	500	PASS
	159/5795	36.180	36.03	500	PASS
802.11ac VHT20	149/5745	17.717	17.53	500	PASS
	157/5785	17.692	15.09	500	PASS
	165/5825	17.707	15.10	500	PASS
802.11ac VHT40	151/5755	36.211	35.41	500	PASS
	159/5795	36.211	35.62	500	PASS
802.11ac VHT80	155/5775	76.640	75.15	500	PASS

U-NII-1, 802.11a
Carrier frequency (MHz): 5180



U-NII-1, 802.11n HT20
Carrier frequency (MHz): 5180



U-NII-1, 802.11a
Carrier frequency (MHz): 5200

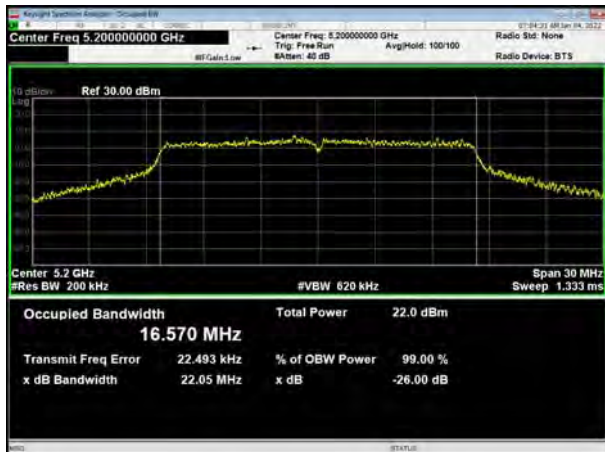

U-NII-1, 802.11n HT20
Carrier frequency (MHz): 5200



U-NII-1, 802.11a
Carrier frequency (MHz):5240



U-NII-1, 802.11n HT20
Carrier frequency (MHz):5240





U-NII-1, 802.11n HT40
Carrier frequency (MHz): 5190

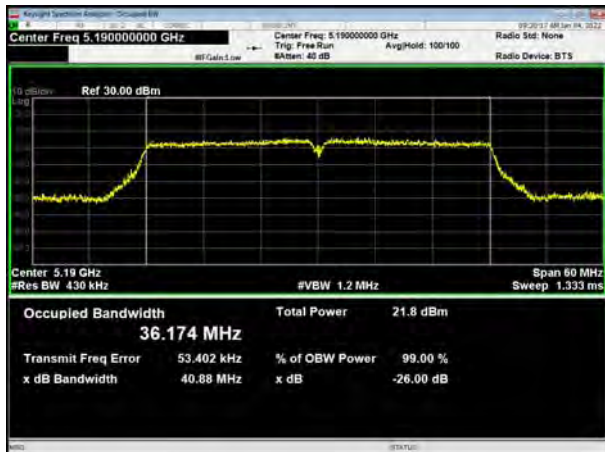

U-NII-1, 802.11ac VHT20
Carrier frequency (MHz): 5180



U-NII-1, 802.11n HT40
Carrier frequency (MHz): 5230

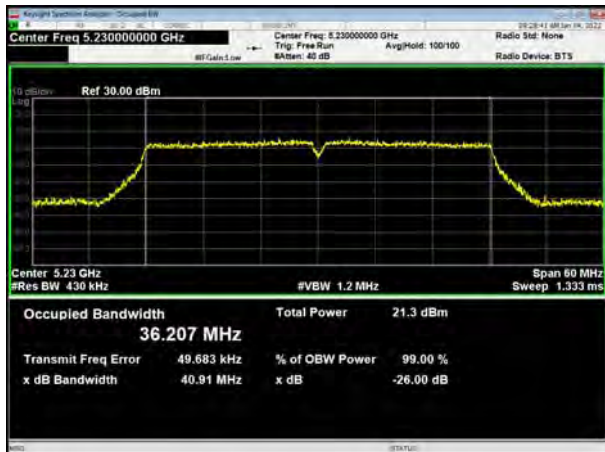

U-NII-1, 802.11ac VHT20
Carrier frequency (MHz): 5200



U-NII-1, 802.11ac VHT40
Carrier frequency (MHz): 5190



U-NII-1, 802.11ac VHT20
Carrier frequency (MHz): 5240



U-NII-1, 802.11ac VHT40
Carrier frequency (MHz): 5230



U-NII-1, 802.11ac VHT80
Carrier frequency (MHz): 5210



U-NII-2A, 802.11a
Carrier frequency (MHz): 5260



U-NII-2A, 802.11n HT20
Carrier frequency (MHz): 5260



U-NII-2A, 802.11a
Carrier frequency (MHz): 5300



U-NII-2A, 802.11n HT20
Carrier frequency (MHz): 5300



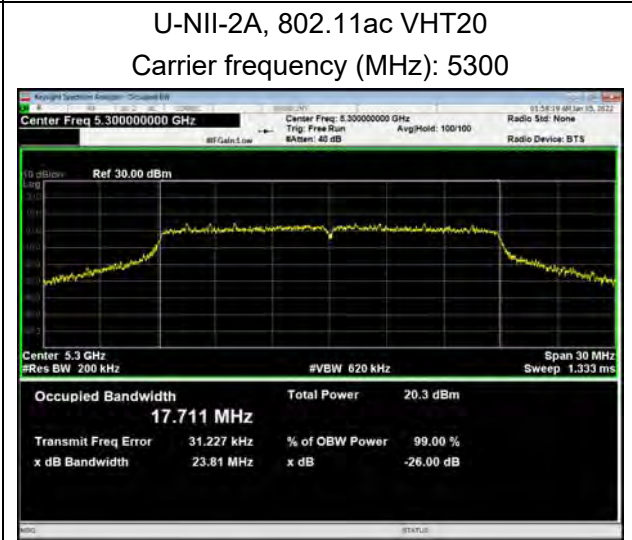
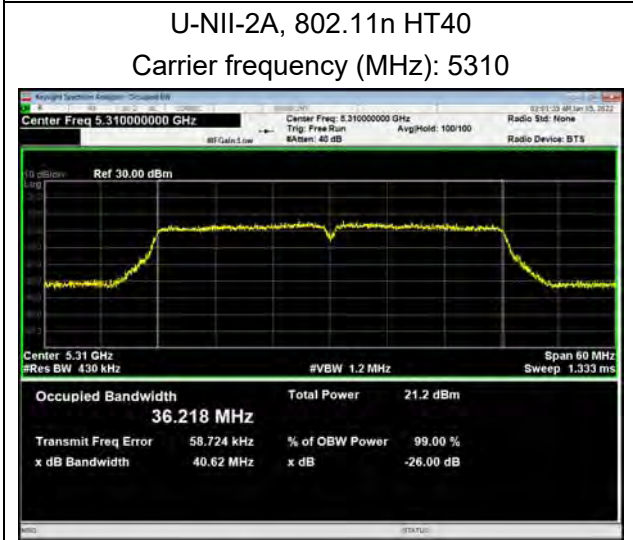
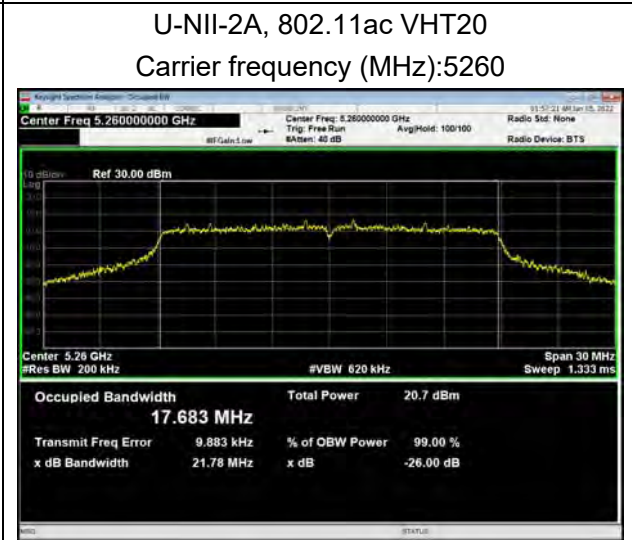
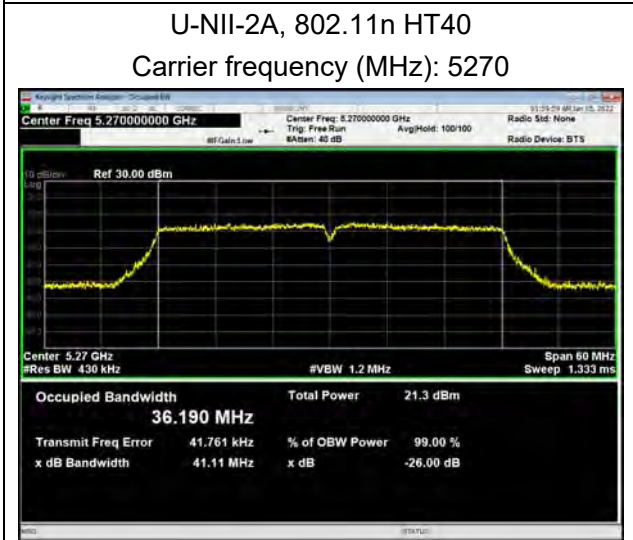
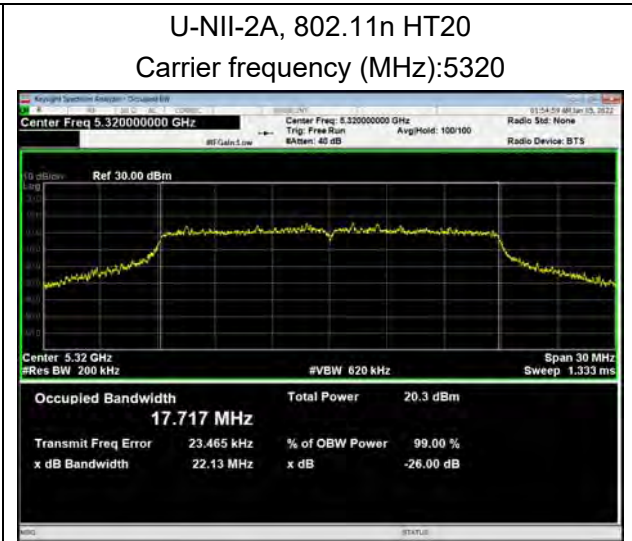
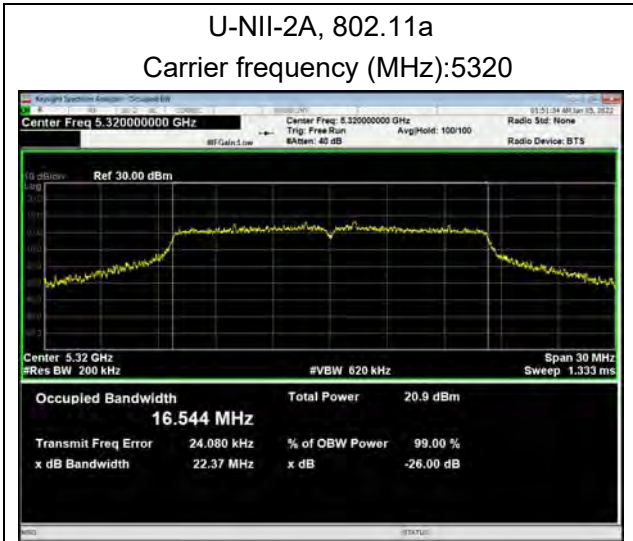

U-NII-2A, 802.11ac VHT40
Carrier frequency (MHz): 5270

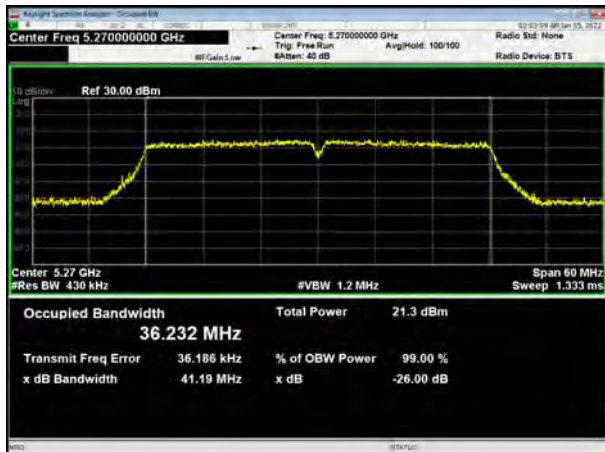

U-NII-2A, 802.11ac VHT20
Carrier frequency (MHz): 5320



U-NII-2A, 802.11ac VHT40
Carrier frequency (MHz): 5310



U-NII-2A, 802.11ac VHT80
Carrier frequency (MHz): 5290

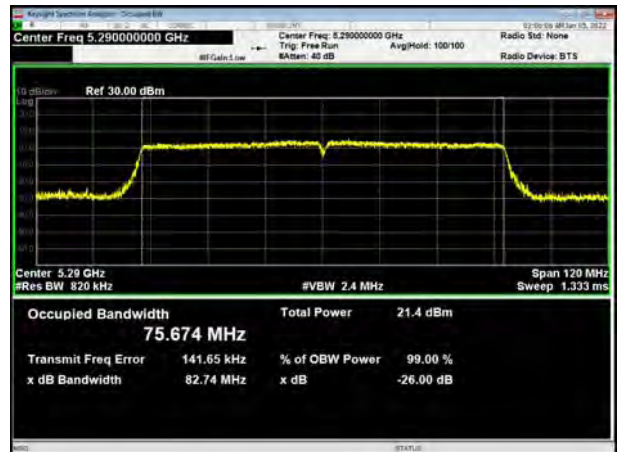

U-NII-2C, 802.11a
Carrier frequency (MHz): 5500



U-NII-2C, 802.11n HT20
Carrier frequency (MHz): 5500





U-NII-2C, 802.11a
Carrier frequency (MHz): 5600



U-NII-2C, 802.11n HT20
Carrier frequency (MHz): 5600



U-NII-2C, 802.11a
Carrier frequency (MHz): 5700



U-NII-2C, 802.11n HT20
Carrier frequency (MHz): 5700



U-NII-2C, 802.11a
Carrier frequency (MHz): 5720

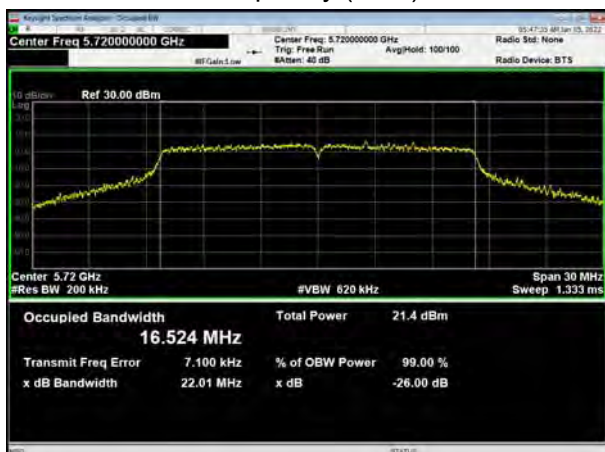

U-NII-2C, 802.11n HT20
Carrier frequency (MHz): 5720





U-NII-2C, 802.11n HT40
Carrier frequency (MHz): 5510



U-NII-2C, 802.11ac VHT20
Carrier frequency (MHz): 5500



U-NII-2C, 802.11n HT40
Carrier frequency (MHz): 5590

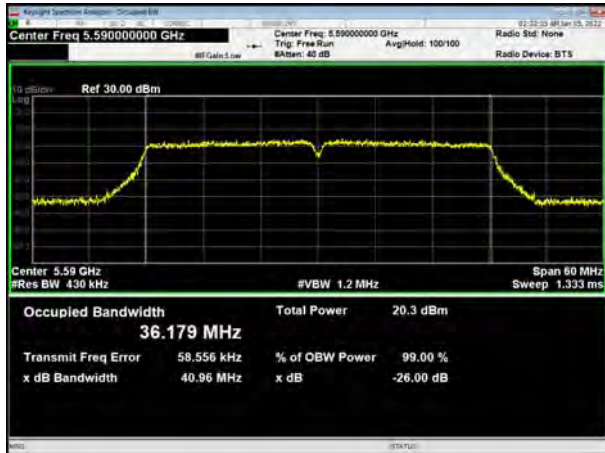

U-NII-2C, 802.11ac VHT20
Carrier frequency (MHz): 5600



U-NII-2C, 802.11n HT40
Carrier frequency (MHz): 5670



U-NII-2C, 802.11ac VHT20
Carrier frequency (MHz): 5700



U-NII-2C, 802.11n HT40
Carrier frequency (MHz): 5710

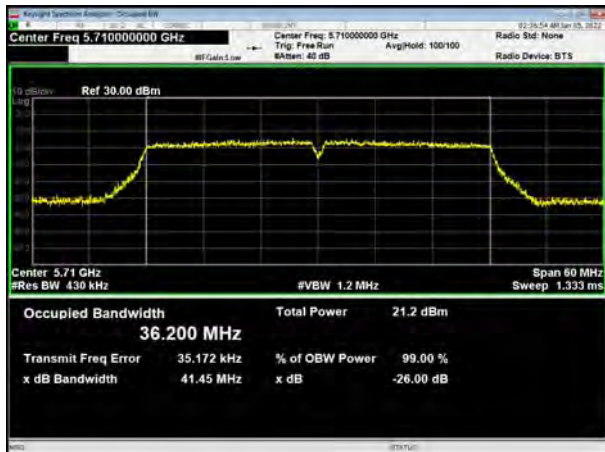

U-NII-2C, 802.11ac VHT20
Carrier frequency (MHz): 5720



U-NII-2C, 802.11ac VHT40
Carrier frequency (MHz): 5510



U-NII-2C, 802.11ac VHT40
Carrier frequency (MHz): 5590



U-NII-2C, 802.11ac VHT40
Carrier frequency (MHz): 5670



U-NII-2C, 802.11ac VHT40
Carrier frequency (MHz): 5710





U-NII-2C, 802.11ac VHT80
Carrier frequency (MHz): 5610



U-NII-2C, 802.11ac VHT80
Carrier frequency (MHz): 5690





99% bandwidth

U-NII-3, 802.11a
Carrier frequency (MHz): 5745



U-NII-3, 802.11n HT20
Carrier frequency (MHz): 5745



U-NII-3, 802.11a
Carrier frequency (MHz): 5785



U-NII-3, 802.11n HT20
Carrier frequency (MHz): 5785



U-NII-3, 802.11a
Carrier frequency (MHz): 5825



U-NII-3, 802.11n HT20
Carrier frequency (MHz): 5825



U-NII-3, 802.11n HT40
Carrier frequency (MHz): 5755

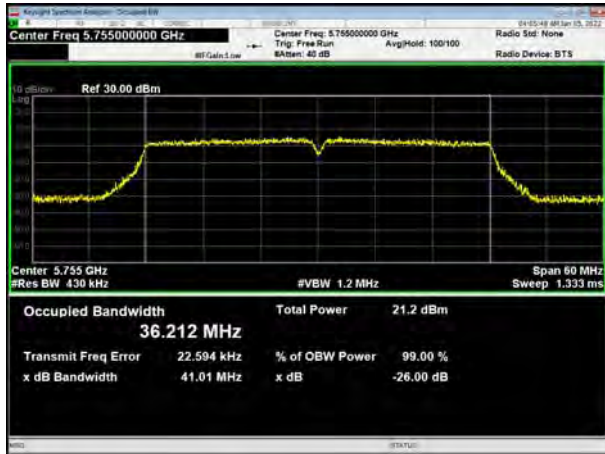

U-NII-3, 802.11ac VHT20
Carrier frequency (MHz): 5745



U-NII-3, 802.11n HT40
Carrier frequency (MHz): 5795



U-NII-3, 802.11ac VHT20
Carrier frequency (MHz): 5785



U-NII-3, 802.11ac VHT40
Carrier frequency (MHz): 5755



U-NII-3, 802.11ac VHT20
Carrier frequency (MHz): 5825





U-NII-3, 802.11ac VHT40
Carrier frequency (MHz): 5795

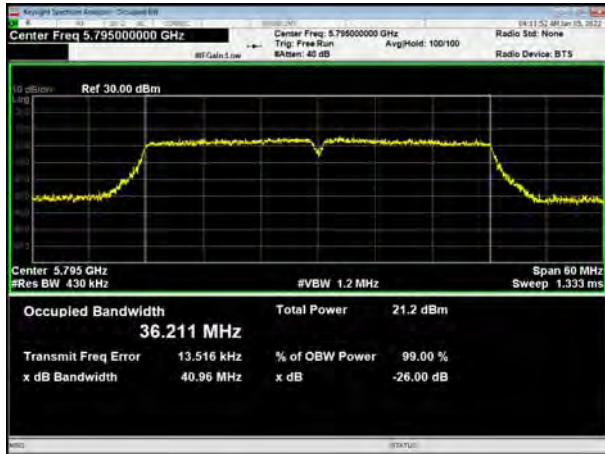

U-NII-3, 802.11ac VHT80
Carrier frequency (MHz): 5775

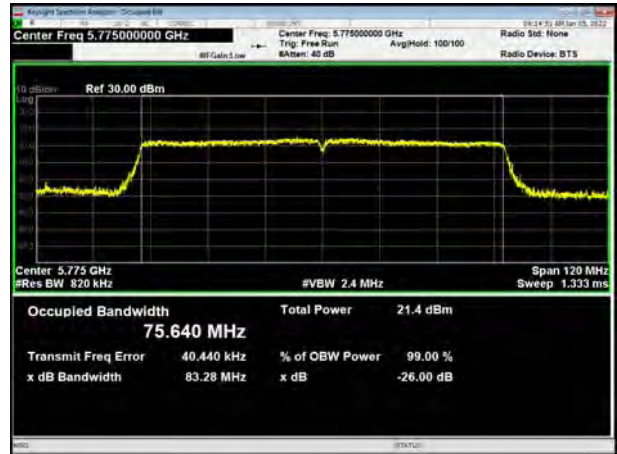



Minimum 6 dB bandwidth

U-NII-3, 802.11a
Carrier frequency (MHz): 5745



U-NII-3, 802.11n HT20
Carrier frequency (MHz): 5745



U-NII-3, 802.11a
Carrier frequency (MHz): 5785



U-NII-3, 802.11n HT20
Carrier frequency (MHz): 5785



U-NII-3, 802.11a
Carrier frequency (MHz): 5825

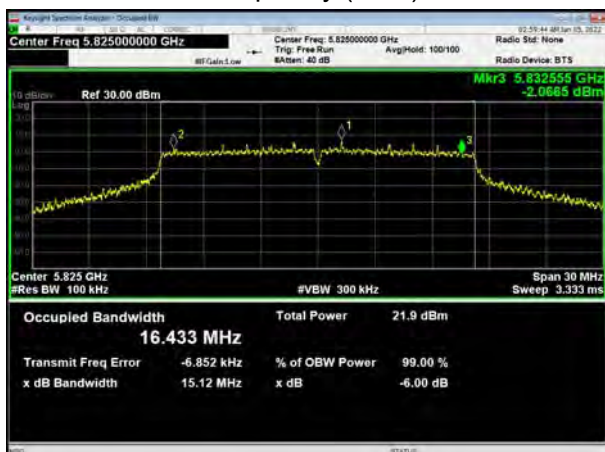

U-NII-3, 802.11n HT20
Carrier frequency (MHz): 5825





U-NII-3, 802.11n HT40
Carrier frequency (MHz): 5755



U-NII-3, 802.11ac VHT20
Carrier frequency (MHz): 5745



U-NII-3, 802.11n HT40
Carrier frequency (MHz): 5795



U-NII-3, 802.11ac VHT20
Carrier frequency (MHz): 5785



U-NII-3, 802.11ac VHT40
Carrier frequency (MHz): 5755



U-NII-3, 802.11ac VHT20
Carrier frequency (MHz): 5825





U-NII-3, 802.11ac VHT40
Carrier frequency (MHz): 5795



U-NII-3, 802.11ac VHT80
Carrier frequency (MHz): 5775



5.2. Average Power Output

Ambient condition

Temperature	Relative humidity	Pressure
23°C ~25°C	45%~50%	101.5kPa

Methods of Measurement

During the process of the testing, The EUT was connected to the average power meter through an external attenuator and a known loss cable. The EUT is max power transmission with proper modulation. We use Maximum average Conducted Output Power Level Method in KDB789033 for this test

Test Setup

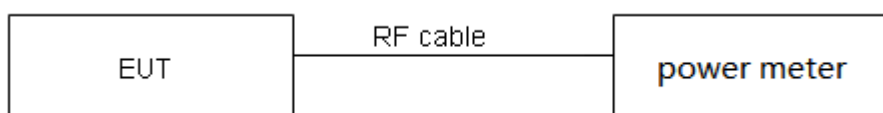

Limits

Rule FCC Part 15.407(a)(1)(2)(3)

(1) For the band 5.15-5.25 GHz.

(i) For an outdoor access point operating in the band 5.15-5.25 GHz, the maximum conducted output power over the frequency band of operation shall not exceed 1 W provided the maximum antenna gain does not exceed 6 dBi. In addition, the maximum power spectral density shall not exceed 17 dBm in any 1 megahertz band. If transmitting antennas of directional gain greater than 6 dBi are used, both the maximum conducted output power and the maximum power spectral density shall be reduced by the amount in dB that the directional gain of the antenna exceeds 6 dBi. The maximum e.i.r.p. at any elevation angle above 30 degrees as measured from the horizon must not exceed 125 mW (21 dBm).

(ii) For an indoor access point operating in the band 5.15-5.25 GHz, the maximum conducted output power over the frequency band of operation shall not exceed 1 W provided the maximum antenna gain does not exceed 6 dBi. In addition, the maximum power spectral density shall not exceed 17 dBm in any 1 megahertz band. If transmitting antennas of directional gain greater than 6 dBi are used, both the maximum conducted output power and the maximum power spectral density shall be reduced by the amount in dB that the directional gain of the antenna exceeds 6 dBi.

(iii) For fixed point-to-point access points operating in the band 5.15-5.25 GHz, the maximum conducted output power over the frequency band of operation shall not exceed 1 W. In addition, the maximum power spectral density shall not exceed 17 dBm in any 1 megahertz band. Fixed point-to-point U-NII devices may employ antennas with directional gain up to 23 dBi without any corresponding reduction in the maximum conducted output power or maximum power spectral density. For fixed point-to-point transmitters that employ a directional antenna gain greater than 23 dBi, a 1 dB reduction in maximum conducted output power and maximum power spectral density is required for each 1 dB of antenna gain in excess of 23 dBi. Fixed, point-to-point operations exclude



the use of point-to-multipoint systems, omnidirectional applications, and multiple collocated transmitters transmitting the same information. The operator of the U-NII device, or if the equipment is professionally installed, the installer, is responsible for ensuring that systems employing high gain directional antennas are used exclusively for fixed, point-to-point operations.

(iv) For client devices in the 5.15-5.25 GHz band, the maximum conducted output power over the frequency band of operation shall not exceed 250 mW provided the maximum antenna gain does not exceed 6 dBi. In addition, the maximum power spectral density shall not exceed 11 dBm in any 1 megahertz band. If transmitting antennas of directional gain greater than 6 dBi are used, both the maximum conducted output power and the maximum power spectral density shall be reduced by the amount in dB that the directional gain of the antenna exceeds 6 dBi.

(2) For the 5.25-5.35 GHz and 5.47-5.725 GHz bands, the maximum conducted output power over the frequency bands of operation shall not exceed the lesser of 250 mW or 11 dBm + 10 log B, where B is the 26 dB emission bandwidth in megahertz. In addition, the maximum power spectral density shall not exceed 11 dBm in any 1 megahertz band. If transmitting antennas of directional gain greater than 6 dBi are used, both the maximum conducted output power and the maximum power spectral density shall be reduced by the amount in dB that the directional gain of the antenna exceeds 6 dBi.

(3) For the band 5.725-5.85 GHz, the maximum conducted output power over the frequency band of operation shall not exceed 1 W. In addition, the maximum power spectral density shall not exceed 30 dBm in any 500-kHz band. If transmitting antennas of directional gain greater than 6 dBi are used, both the maximum conducted output power and the maximum power spectral density shall be reduced by the amount in dB that the directional gain of the antenna exceeds 6 dBi.

Measurement Uncertainty

The assessed measurement uncertainty to ensure 95% confidence level for the normal distribution is with the coverage factor $k = 2$, $U = 0.44$ dB.

Test Results

Mode	T _{on} (ms)	T _(on+off) (ms)	Duty cycle	Duty cycle correction Factor(dB)
802.11a	1.390	1.418	0.980	0.00
802.11n HT20	1.300	1.340	0.970	0.13
802.11n HT40	0.644	0.680	0.947	0.24
802.11ac VHT20	1.302	1.338	0.973	0.12
802.11ac VHT40	0.644	0.680	0.947	0.24
802.11ac VHT80	0.324	0.360	0.900	0.46

Note: when Duty cycle ≥ 0.98 , Duty cycle correction Factor not required.

Power Index								
Channel	802.11a	802.11n HT20	802.11ac VHT20	Channel	802.11n HT40	802.11ac VHT40	Channel	802.11ac VHT80
CH36	15	15	15	CH38	13	13	CH42	13
CH40	15	15	15	CH46	13	13	/	/
CH48	15	15	15	/	/	/	/	/
CH52	15	15	15	CH54	13	13	CH58	13
CH60	15	15	15	CH62	13	13	/	/
CH64	15	15	15	/	/	/	/	/
CH100	14	14	14	CH102	13	13	CH122	13
CH120	14	14	14	CH118	13	13	CH138	13
CH140	14	14	14	CH134	13	13	/	/
CH144	14	14	14	CH142	13	13	/	/
CH149	13	13	13	CH151	13	13	CH155	13
CH157	13	13	13	CH159	13	13	/	/
CH165	13	13	13	/	/	/	/	/



Test Mode		Channel/Frequency (MHz)	B=26 dB bandwidth (MHz)	Limit 11 dBm + 10 log B (dBm)	Final Limit(dBm)
U-NII-2A	802.11a	52/5260	23.84	24.77>24	24.00
		60/5300	21.44	24.31>24	24.00
		64/5320	22.37	24.50>24	24.00
	802.11n HT20	52/5260	22.69	24.56>24	24.00
		60/5300	23.18	24.65>24	24.00
		64/5320	22.13	24.45>24	24.00
	802.11n HT40	54/5270	41.11	27.14>24	24.00
		62/5310	40.62	27.09>24	24.00
	802.11ac VHT20	52/5260	21.78	24.38>24	24.00
		60/5300	23.81	24.77>24	24.00
64/5320		21.75	24.37>24	24.00	
802.11ac VHT40	54/5270	41.19	27.15>24	24.00	
	62/5310	41.72	27.20>24	24.00	
802.11ac VHT80	58/5290	82.74	30.18>24	24.00	
U-NII-2C	802.11a	100/5500	22.26	24.48>24	24.00
		120/5600	22.92	24.60>24	24.00
		140/5700	22.13	24.45>24	24.00
		144/5720	22.01	24.43>24	24.00
	802.11n HT20	100/5500	23.12	24.64>24	24.00
		120/5600	22.22	24.47>24	24.00
		140/5700	21.72	24.37>24	24.00
		144/5720	22.57	24.54>24	24.00
	802.11n HT40	102/5510	40.87	27.11>24	24.00
		118/5590	40.96	27.12>24	24.00
		134/5670	41.03	27.13>24	24.00
		142/5710	41.45	27.18>24	24.00
	802.11ac VHT20	100/5500	21.92	24.41>24	24.00
		120/5600	23.24	24.66>24	24.00
		140/5700	23.54	24.72>24	24.00
		144/5720	23.12	24.64>24	24.00
	802.11ac VHT40	102/5510	40.13	27.03>24	24.00
		118/5590	41.04	27.13>24	24.00
		134/5670	40.96	27.12>24	24.00
		142/5710	40.62	27.09>24	24.00
802.11ac VHT80	122/5610	83.86	30.24>24	24.00	
	138/5690	82.06	30.14>24	24.00	

Note: 250mW=24dBm

Note: Average Power with duty factor = Average Power Measured +Duty cycle correction factor



U-NII-1

Test Mode	Channel/ Frequency (MHz)	Average Power Measured (dBm)	Average Power with duty factor (dBm)	Limit (dBm)	Conclusion
802.11a	36/5180	14.56	14.56	24.00	PASS
	40/5200	14.45	14.45	24.00	PASS
	48/5240	14.35	14.35	24.00	PASS
802.11n HT20	36/5180	14.37	14.50	24.00	PASS
	40/5200	14.34	14.47	24.00	PASS
	48/5240	14.21	14.34	24.00	PASS
802.11n HT40	38/5190	13.26	13.50	24.00	PASS
	46/5230	13.14	13.38	24.00	PASS
802.11ac VHT20	36/5180	14.33	14.45	24.00	PASS
	40/5200	14.32	14.44	24.00	PASS
	48/5240	14.23	14.35	24.00	PASS
802.11ac VHT40	38/5190	13.33	13.57	24.00	PASS
	46/5230	13.18	13.42	24.00	PASS
802.11ac VHT80	42/5210	12.73	13.19	24.00	PASS

Note: Average Power with duty factor = Average Power Measured +Duty cycle correction factor



U-NII-2A

Test Mode	Channel/ Frequency (MHz)	Average Power Measured (dBm)	Average Power with duty factor (dBm)	Limit (dBm)	Conclusion
802.11a	52/5260	14.35	14.35	24.00	PASS
	60/5300	14.57	14.57	24.00	PASS
	64/5320	14.54	14.54	24.00	PASS
802.11n HT20	52/5260	14.13	14.26	24.00	PASS
	60/5300	14.38	14.51	24.00	PASS
	64/5320	14.47	14.60	24.00	PASS
802.11n HT40	54/5270	13.15	13.39	24.00	PASS
	62/5310	13.38	13.62	24.00	PASS
802.11ac VHT20	52/5260	14.21	14.33	24.00	PASS
	60/5300	14.41	14.53	24.00	PASS
	64/5320	14.39	14.51	24.00	PASS
802.11ac VHT40	54/5270	13.15	13.39	24.00	PASS
	62/5310	13.35	13.59	24.00	PASS
802.11ac VHT80	58/5290	12.74	13.20	24.00	PASS

Note: Average Power with duty factor = Average Power Measured +Duty cycle correction factor



U-NII-2C

Test Mode	Channel/ Frequency (MHz)	Average Power Measured (dBm)	Average Power with duty factor (dBm)	Limit (dBm)	Conclusion
802.11a	100/5500	12.48	12.48	24.00	PASS
	120/5600	12.93	12.93	24.00	PASS
	140/5700	12.41	12.41	24.00	PASS
	144/5720	12.46	12.46	24.00	PASS
802.11n HT20	100/5500	12.28	12.41	24.00	PASS
	120/5600	12.78	12.91	24.00	PASS
	140/5700	12.19	12.32	24.00	PASS
	144/5720	12.27	12.40	24.00	PASS
802.11n HT40	102/5510	12.38	12.62	24.00	PASS
	118/5590	12.39	12.63	24.00	PASS
	134/5670	12.12	12.36	24.00	PASS
	142/5710	11.98	12.22	24.00	PASS
802.11ac VHT20	100/5500	12.31	12.43	24.00	PASS
	120/5600	12.81	12.93	24.00	PASS
	140/5700	12.25	12.37	24.00	PASS
	144/5720	12.29	12.41	24.00	PASS
802.11ac VHT40	102/5510	12.28	12.52	24.00	PASS
	118/5590	12.36	12.60	24.00	PASS
	134/5670	12.09	12.33	24.00	PASS
	142/5710	11.96	12.20	24.00	PASS
802.11ac VHT80	122/5610	12.01	12.47	24.00	PASS
	138/5690	11.49	11.95	24.00	PASS

Note: Average Power with duty factor = Average Power Measured +Duty cycle correction factor



U-NII-3

Test Mode	Channel/ Frequency (MHz)	Average Power Measured (dBm)	Average Power with duty factor (dBm)	Limit (dBm)	Conclusion
802.11a	149/5745	11.52	11.52	30.00	PASS
	157/5785	11.90	11.90	30.00	PASS
	165/5825	12.20	12.20	30.00	PASS
802.11n HT20	149/5745	11.31	11.44	30.00	PASS
	157/5785	11.68	11.81	30.00	PASS
	165/5825	12.04	12.17	30.00	PASS
802.11n HT40	151/5755	12.05	12.29	30.00	PASS
	159/5795	12.61	12.85	30.00	PASS
802.11ac VHT20	149/5745	11.30	11.42	30.00	PASS
	157/5785	11.72	11.84	30.00	PASS
	165/5825	12.09	12.21	30.00	PASS
802.11ac VHT40	151/5755	12.06	12.30	30.00	PASS
	159/5795	12.61	12.85	30.00	PASS
802.11ac VHT80	155/5775	11.73	12.19	30.00	PASS

Note: Average Power with duty factor = Average Power Measured +Duty cycle correction factor

5.3. Frequency Stability

Ambient condition

Temperature	Relative humidity	Pressure
23°C ~25°C	45%~50%	101.5kPa

Method of Measurement

1. Frequency stability with respect to ambient temperature

a) Supply the EUT with a nominal ac voltage or install a new or fully charged battery in the EUT. If possible, a dummy load shall be connected to the EUT because an antenna near the metallic walls of an environmental test chamber could affect the output frequency of the EUT. If the EUT is equipped with a permanently attached, adjustable-length antenna, then the EUT shall be placed in the center of the chamber with the antenna adjusted to the shortest length possible. Turn ON the EUT and tune it to one of the number of frequencies shown in 5.6.

b) Couple the unlicensed wireless device output to the measuring instrument by connecting an antenna to the measuring instrument with a suitable length of coaxial cable and placing the measuring antenna near the EUT (e.g., 15 cm away), or by connecting a dummy load to the measuring instrument, through an attenuator if necessary.

c) Adjust the location of the measurement antenna and the controls on the measurement instrument to obtain a suitable signal level (i.e., a level that will not overload the measurement instrument but is strong enough to allow measurement of the operating or fundamental frequency of the EUT).

d) Turn the EUT OFF and place it inside the environmental temperature chamber. For devices that have oscillator heaters, energize only the heater circuit.

e) Set the temperature control on the chamber to the highest specified in the regulatory requirements for the type of device and allow the oscillator heater and the chamber temperature to stabilize.

f) While maintaining a constant temperature inside the environmental chamber, turn the EUT ON and record the operating frequency at startup, and at 2 minutes, 5 minutes, and 10 minutes after the EUT is energized. Four measurements in total are made.

g) Measure the frequency at each of frequencies specified in 5.6.

h) Switch OFF the EUT but do not switch OFF the oscillator heater.

i) Lower the chamber temperature by not more than 10°C, and allow the temperature inside the chamber to stabilize.

j) Repeat step f) through step i) down to the lowest specified temperature.

2. Frequency stability when varying supply voltage

Unless otherwise specified, these tests shall be made at ambient room temperature (+15°C to +25 °C). An antenna shall be connected to the antenna output terminals of the EUT if possible. If the EUT is equipped with or uses an adjustable-length antenna, then it shall be fully extended.

a) Supply the EUT with nominal voltage or install a new or fully charged battery in the EUT. Turn ON the EUT and couple its output to a frequency counter or other frequency-measuring instrument.



- b) Tune the EUT to one of the number of frequencies required in 5.6. Adjust the location of the measurement antenna and the controls on the measurement instrument to obtain a suitable signal level (i.e., a level that will not overload the measurement instrument but is strong enough to allow measurement of the operating or fundamental frequency of the EUT).
- c) Measure the frequency at each of the frequencies specified in 5.6.
- d) Repeat the above procedure at 85% and 115% of the nominal supply voltage.

Limit

Manufacturers of U-NII devices are responsible for ensuring frequency stability such that an emission is maintained within the band of operation under all conditions of normal operation as specified in the users manual.

Measurement Uncertainty

The assessed measurement uncertainty to ensure 95% confidence level for the normal distribution is with the coverage factor $k = 2$, $U = 936\text{Hz}$

**Test Results**

Voltage (V)	Temperature (°C)	U-NII-1 Test Results			
		5200MHz			
		1min	2min	5min	10min
3.87	-20	5199.997177	5199.993525	5199.987525	5199.980488
3.87	-10	5200.003585	5199.993037	5199.983155	5199.975280
3.87	0	5199.999460	5199.990090	5199.974118	5199.969053
3.87	10	5199.995698	5199.986859	5199.971803	5199.965186
3.87	20	5199.994323	5199.978467	5199.968969	5199.957912
3.87	30	5199.990952	5199.975624	5199.964239	5199.955602
3.87	40	5199.989737	5199.969668	5199.957969	5199.948239
3.87	50	5199.981189	5199.960243	5199.954522	5199.939486
3.6	20	5199.977001	5199.950942	5199.946700	5199.937787
4.2	20	5199.967003	5199.942690	5199.939705	5199.937121
Max. ΔMHz		-0.032997	-0.057310	-0.060295	-0.062879
PPM		-6.345671	-11.021140	-11.595205	-12.092150

Voltage (V)	Temperature (°C)	U-NII-2A Test Results			
		5300MHz			
		1min	2min	5min	10min
3.87	-20	5300.008080	5300.006090	5300.004447	5300.000122
3.87	-10	5299.998294	5299.999555	5299.997778	5300.000115
3.87	0	5299.988559	5299.997003	5299.995196	5300.000023
3.87	10	5299.980153	5299.989691	5299.986237	5299.994222
3.87	20	5299.975246	5299.987653	5299.983927	5299.989357
3.87	30	5299.973956	5299.982820	5299.975790	5299.979839
3.87	40	5299.966708	5299.980344	5299.970376	5299.974761
3.87	50	5299.960762	5299.979107	5299.960448	5299.966986
3.6	20	5299.954617	5299.976327	5299.959200	5299.963279
4.2	20	5299.952671	5299.966780	5299.955151	5299.959174
Max. ΔMHz		-0.047329	-0.033220	-0.044849	-0.040826
PPM		-8.929960	-6.267936	-8.462003	-7.703055



Voltage (V)	Temperature (°C)	U-NII-2C Test Results			
		5580MHz			
		1min	2min	5min	10min
3.87	-20	5579.996046	5579.992609	5579.987103	5579.979832
3.87	-10	5579.994062	5579.990860	5579.981356	5579.973827
3.87	0	5579.990894	5579.986690	5579.976565	5579.964660
3.87	10	5579.987341	5579.978553	5579.970351	5579.960640
3.87	20	5579.979769	5579.969637	5579.969053	5579.957780
3.87	30	5579.977860	5579.960934	5579.960023	5579.957640
3.87	40	5579.974918	5579.959142	5579.954503	5579.957481
3.87	50	5579.970561	5579.949262	5579.953558	5579.955078
3.6	20	5579.965740	5579.946584	5579.944332	5579.952405
4.2	20	5579.965252	5579.942313	5579.939237	5579.943943
Max. ΔMHz		-0.034748	-0.057687	-0.060763	-0.056057
PPM		-6.227238	-10.338090	-10.889473	-10.046017

Voltage (V)	Temperature (°C)	U-NII-3 Test Results			
		5785MHz			
		1min	2min	5min	10min
3.87	-20	5784.991614	5784.988521	5784.987659	5784.978582
3.87	-10	5784.983690	5784.980470	5784.983679	5784.972244
3.87	0	5784.982904	5784.972075	5784.980338	5784.963153
3.87	10	5784.973414	5784.967917	5784.970659	5784.959679
3.87	20	5784.967310	5784.966325	5784.968973	5784.954496
3.87	30	5784.966478	5784.959647	5784.967165	5784.948355
3.87	40	5784.966001	5784.959118	5784.957547	5784.942020
3.87	50	5784.960040	5784.951235	5784.948381	5784.938167
3.6	20	5784.955739	5784.948348	5784.940521	5784.936226
4.2	20	5784.953414	5784.942684	5784.939618	5784.931097
Max. ΔMHz		-0.046586	-0.057316	-0.060382	-0.068903
PPM		-8.052910	-9.907669	-10.437765	-11.910693

5.4. Power Spectral Density

Ambient condition

Temperature	Relative humidity	Pressure
23°C ~25°C	45%~50%	101.5kPa

Method of Measurement

The EUT was connected to the spectrum analyzer through an external attenuator (20dB) and a known loss cable.

Set RBW = 1MHz, VBW =3MHz for the band 5.150-5.250GHz, 5.250-5.350GHz, 5.470-5.725GHz.
 Set RBW = 470kHz, VBW =1.5MHz for the band 5.725-5.850GHz

The conducted PSD is measured at each antenna port. The measured results at the various antenna ports are then summed mathematically.

Test setup

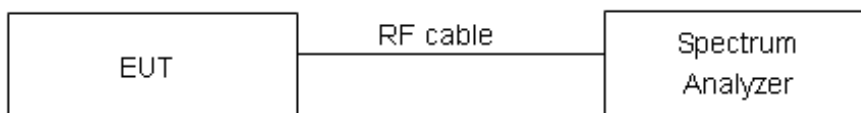

Limits

Rule FCC Part 15.407(a)(1)/ Part 15.407(a)(2) / Part 15.407(a)(3)

For an indoor access point operating in the band 5.15-5.25 GHz, the maximum power spectral density shall not exceed 17 dBm in any 1 megahertz band. If transmitting antennas of directional gain greater than 6 dBi are used, both the maximum conducted output power and the maximum power spectral density shall be reduced by the amount in dB that the directional gain of the antenna exceeds 6 dBi.

For client devices in the 5.15-5.25 GHz band, the maximum conducted output power over the frequency band of operation shall not exceed 250 mW provided the maximum antenna gain does not exceed 6 dBi. In addition, the maximum power spectral density shall not exceed 11 dBm in any 1 megahertz band. If transmitting antennas of directional gain greater than 6 dBi are used, both the maximum conducted output power and the maximum power spectral density shall be reduced by the amount in dB that the directional gain of the antenna exceeds 6 dBi.

For the 5.25-5.35 GHz and 5.47-5.725 GHz bands, the maximum power spectral density shall not exceed 11 dBm in any 1 megahertz band. If transmitting antennas of directional gain greater than 6 dBi are used, both the maximum conducted output power and the maximum power spectral density shall be reduced by the amount in dB that the directional gain of the antenna exceeds 6 dBi.

For the band 5.725-5.85 GHz, the maximum power spectral density shall not exceed 30 dBm in any 500kHz band. If transmitting antennas of directional gain greater than 6 dBi are used, both the maximum conducted output power and the maximum power spectral density shall be reduced by the



amount in dB that the directional gain of the antenna exceeds 6 dBi.

Frequency Bands/MHz	Limits
5150-5250	17/11dBm/MHz
5.25-5.35 GHz and 5.47-5.725 GHz	11dBm/MHz
5725-5850	30dBm/500kHz

Measurement Uncertainty

The assessed measurement uncertainty to ensure 95% confidence level for the normal distribution is with the coverage factor $k = 2$, $U = 0.75\text{dB}$.

**Test Results:**

Note: Power Spectral Density =Read Value+Duty cycle correction factor

U-NII-1

Mode	Channel Number	Read Value (dBm /MHz)	Power Spectral Density (dBm /MHz)	Limit (dBm /MHz)	Conclusion
802.11a	36/5180	4.68	4.68	11	PASS
	40/5200	4.82	4.82	11	PASS
	48/5240	4.65	4.65	11	PASS
802.11n HT20	36/5180	4.17	4.30	11	PASS
	40/5200	4.63	4.76	11	PASS
	48/5240	3.82	3.95	11	PASS
802.11n HT40	38/5190	0.59	0.83	11	PASS
	46/5230	0.07	0.31	11	PASS
802.11ac VHT20	36/5180	4.25	4.37	11	PASS
	40/5200	4.59	4.71	11	PASS
	48/5240	4.09	4.21	11	PASS
802.11ac VHT40	38/5190	0.12	0.36	11	PASS
	46/5230	0.06	0.30	11	PASS
802.11ac VHT80	42/5210	-3.35	-2.89	11	PASS

U-NII-2A

Mode	Channel Number	Read Value (dBm /MHz)	Power Spectral Density (dBm /MHz)	Limit (dBm /MHz)	Conclusion
802.11a	52/5260	4.37	4.37	11	PASS
	60/5300	4.73	4.73	11	PASS
	64/5320	4.78	4.78	11	PASS
802.11n HT20	52/5260	4.02	4.15	11	PASS
	60/5300	4.05	4.18	11	PASS
	64/5320	4.18	4.31	11	PASS
802.11n HT40	54/5270	-0.19	0.05	11	PASS
	62/5310	0.18	0.42	11	PASS
802.11ac VHT20	52/5260	4.05	4.17	11	PASS
	60/5300	4.22	4.34	11	PASS
	64/5320	4.34	4.46	11	PASS
802.11ac VHT40	54/5270	-0.16	0.08	11	PASS
	62/5310	0.12	0.36	11	PASS
802.11ac VHT80	58/5290	-3.46	-3.00	11	PASS



U-NII-2C

Mode	Channel Number	Read Value (dBm /MHz)	Power Spectral Density (dBm /MHz)	Limit (dBm /MHz)	Conclusion
802.11a	100/5500	2.41	2.41	11	PASS
	120/5600	3.21	3.21	11	PASS
	140/5700	2.80	2.80	11	PASS
	144/5720	2.60	2.60	11	PASS
802.11n HT20	100/5500	2.09	2.22	11	PASS
	120/5600	2.99	3.12	11	PASS
	140/5700	2.59	2.72	11	PASS
	144/5720	2.19	2.32	11	PASS
802.11n HT40	102/5510	-0.71	-0.47	11	PASS
	118/5590	-0.28	-0.04	11	PASS
	134/5670	-0.46	-0.22	11	PASS
	142/5710	-0.78	-0.54	11	PASS
802.11ac VHT20	100/5500	2.20	2.32	11	PASS
	120/5600	2.86	2.98	11	PASS
	140/5700	2.28	2.40	11	PASS
	144/5720	2.20	2.32	11	PASS
802.11ac VHT40	102/5510	-0.75	-0.51	11	PASS
	118/5590	-0.42	-0.18	11	PASS
	134/5670	-0.57	-0.33	11	PASS
	142/5710	-0.87	-0.63	11	PASS
802.11ac VHT80	122/5610	-3.95	-3.49	11	PASS
	138/5690	-4.35	-3.89	11	PASS



U-NII-3

Mode	Channel Number	Read Value (dBm/470kHz)	Power Spectral Density (dBm/500kHz)	Limit (dBm/500kHz)	Conclusion
802.11a	149	-1.42	-1.15	30	PASS
	157	-1.49	-1.22	30	PASS
	165	-0.77	-0.50	30	PASS
802.11n HT20	149	-2.01	-1.61	30	PASS
	157	-1.81	-1.41	30	PASS
	165	-1.67	-1.27	30	PASS
802.11n HT40	151	-4.62	-4.11	30	PASS
	159	-3.76	-3.25	30	PASS
802.11ac VHT20	149	-1.89	-1.50	30	PASS
	157	-1.89	-1.50	30	PASS
	165	-1.64	-1.25	30	PASS
802.11ac VHT40	151	-4.40	-3.89	30	PASS
	159	-4.26	-3.75	30	PASS
802.11ac VHT80	155	-7.93	-7.20	30	PASS

Note: $PSD = \text{Read Value} + \text{Duty cycle correction factor} + 10 \cdot \text{LOG}_{10}(500/470)$

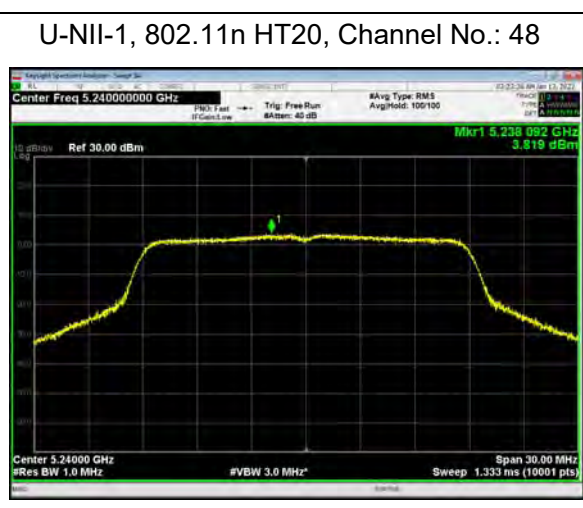
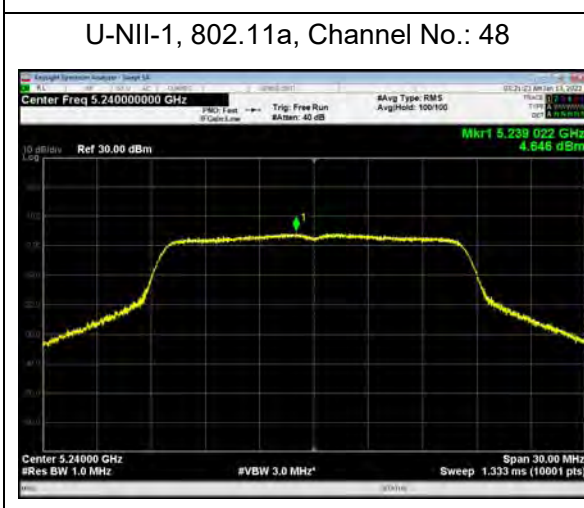
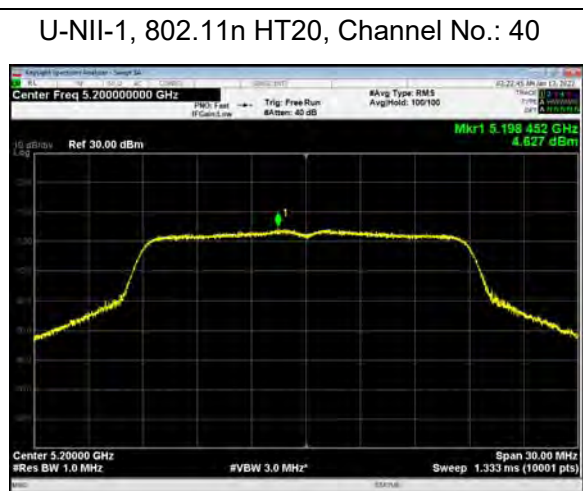
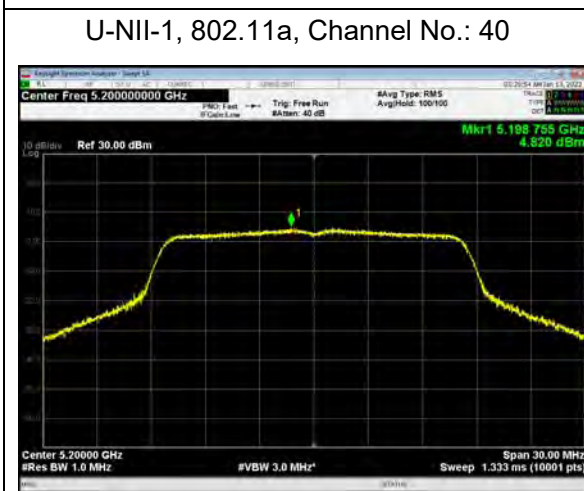
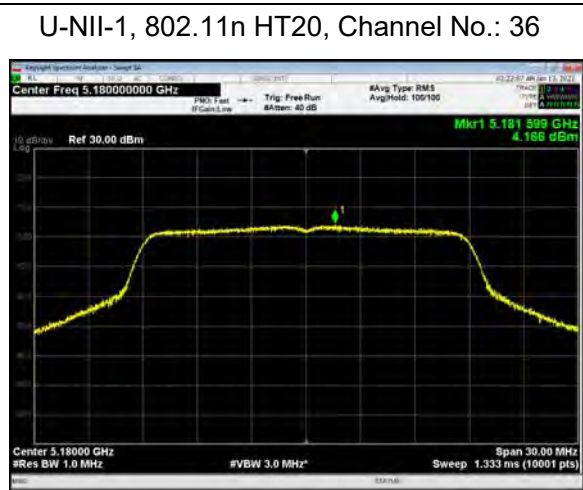
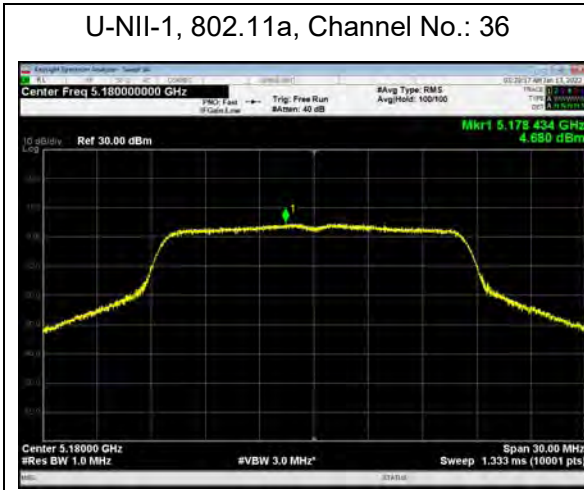

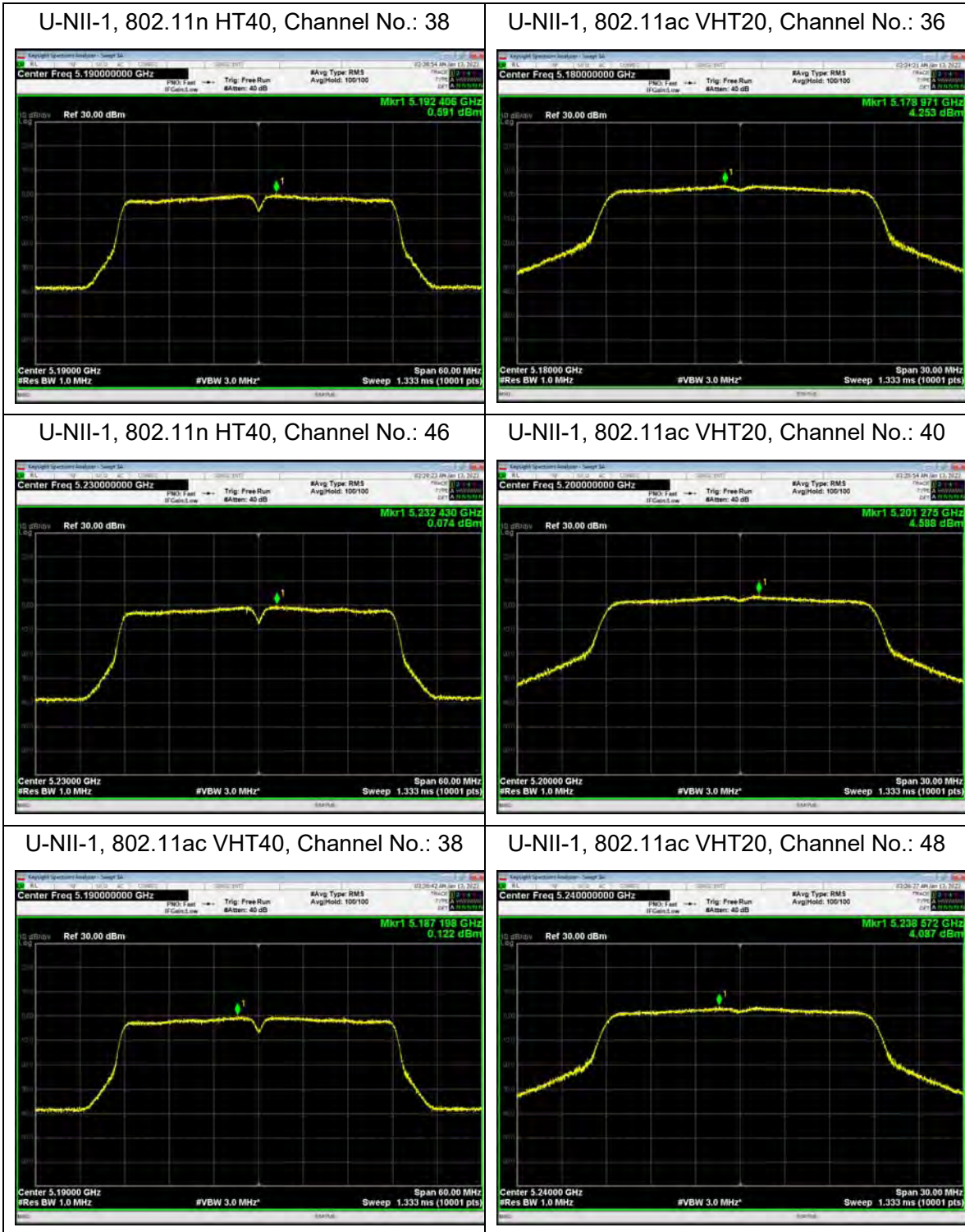

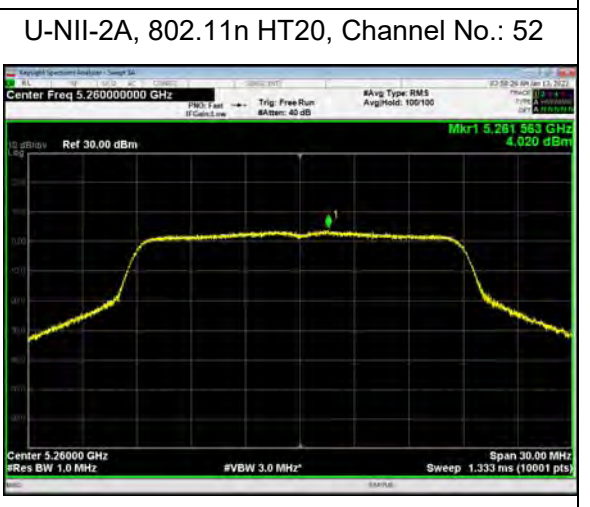
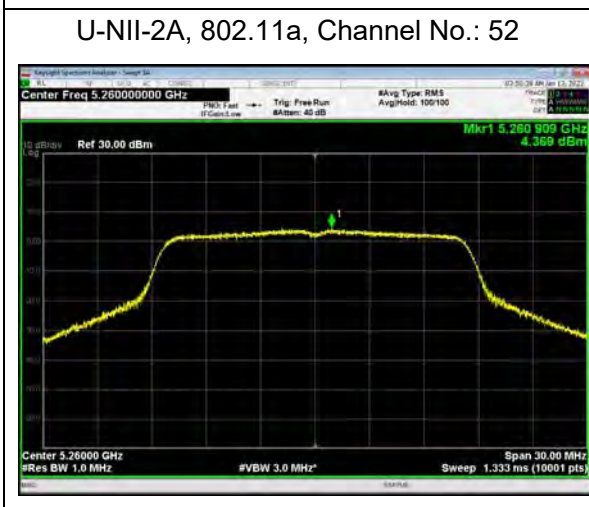
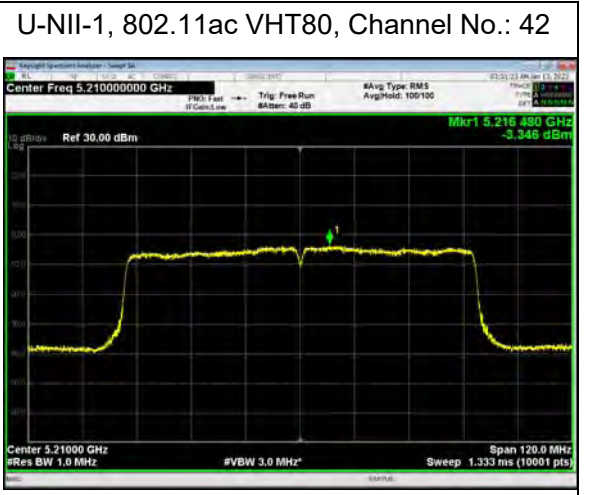
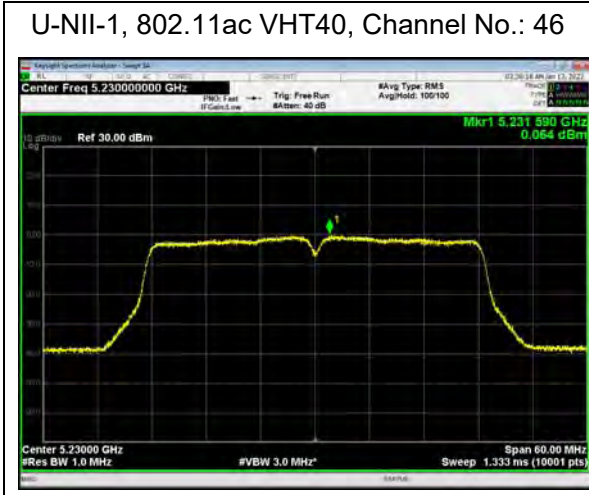

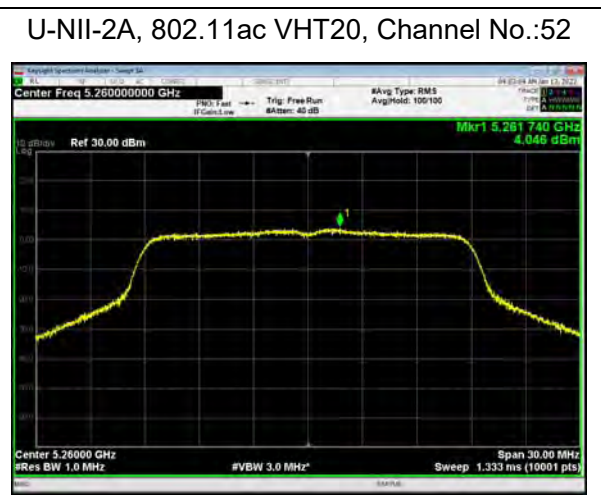
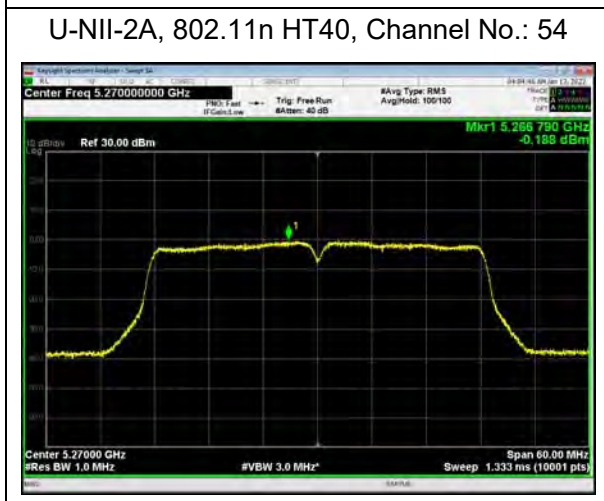
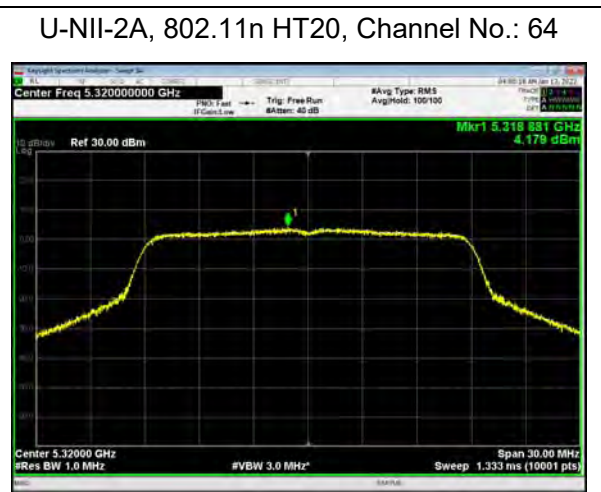
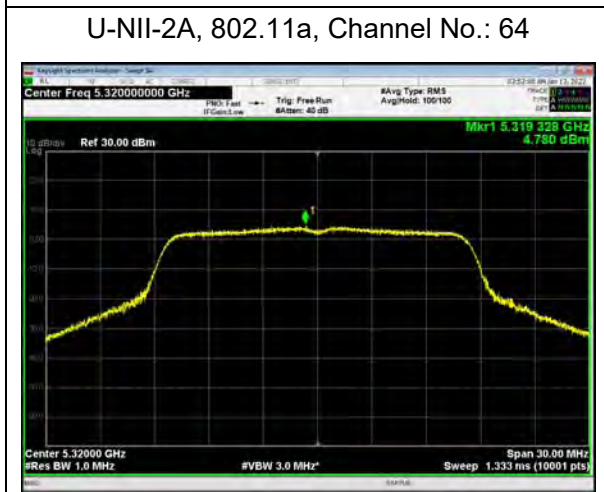
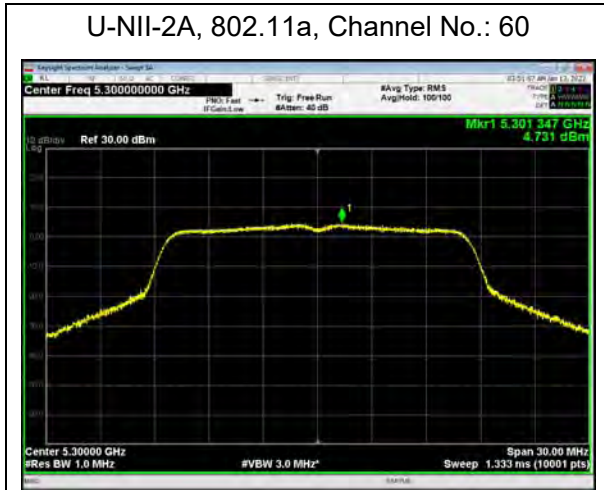

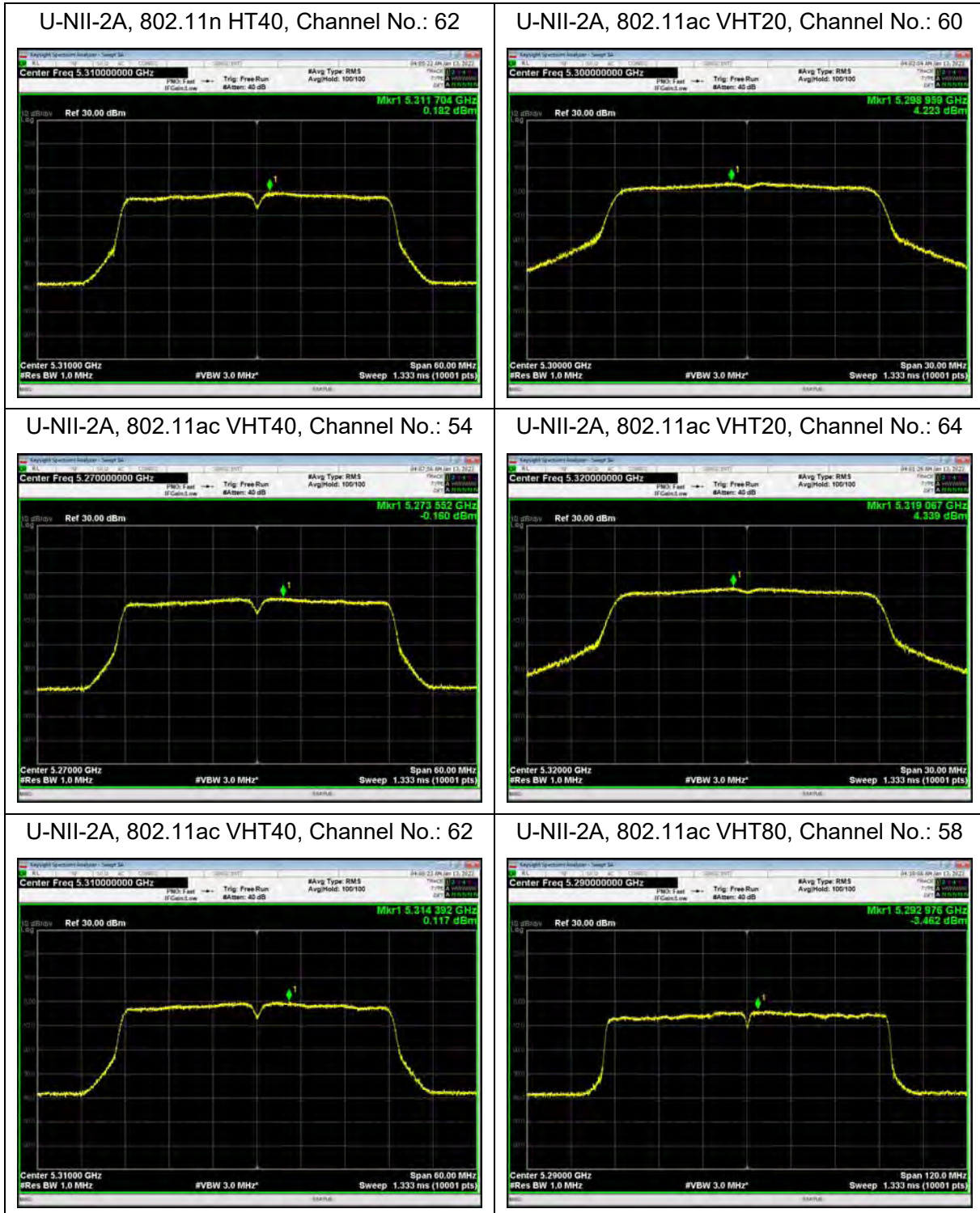

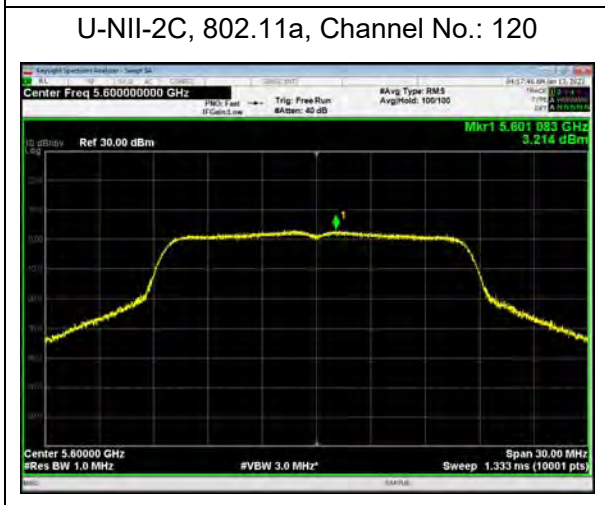
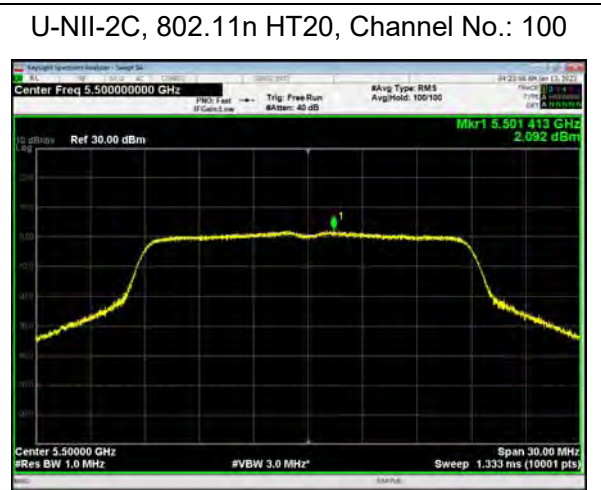
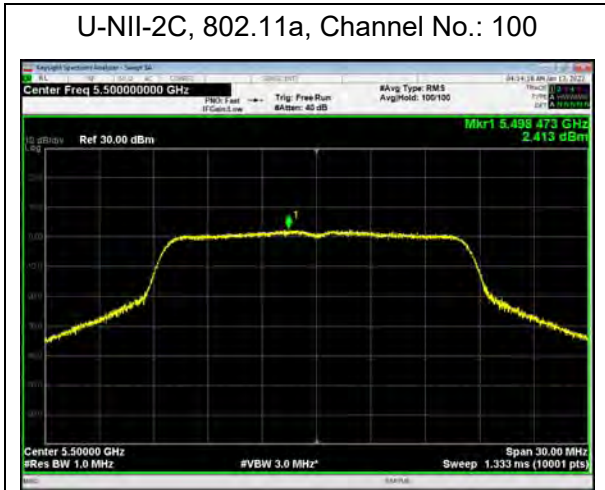

U-NII-2C, 802.11a, Channel No.: 140

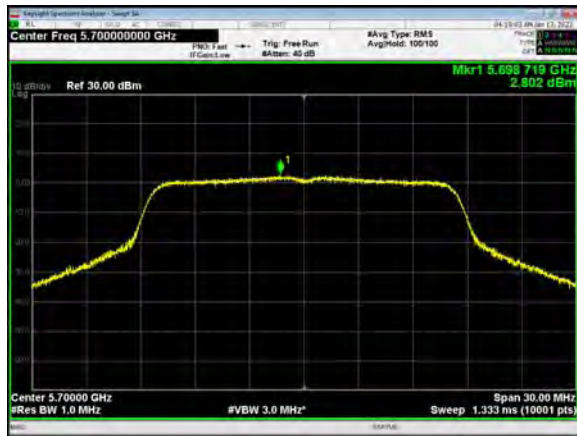

U-NII-2C, 802.11n HT20, Channel No.: 140



U-NII-2C, 802.11a, Channel No.: 144



U-NII-2C, 802.11n HT20, Channel No.: 144



U-NII-2C, 802.11n HT40, Channel No.: 102



U-NII-2C, 802.11ac VHT20, Channel No.: 100



U-NII-2C, 802.11n HT40, Channel No.: 118



U-NII-2C, 802.11ac VHT20, Channel No.: 120



U-NII-2C, 802.11n HT40, Channel No.: 134



U-NII-2C, 802.11ac VHT20, Channel No.: 140



U-NII-2C, 802.11n HT40, Channel No.: 142



U-NII-2C, 802.11ac VHT20, Channel No.: 144





U-NII-2C, 802.11ac VHT40, Channel No.: 102



U-NII-2C, 802.11ac VHT40, Channel No.: 118



U-NII-2C, 802.11ac VHT40, Channel No.: 134



U-NII-2C, 802.11ac VHT40, Channel No.: 142





U-NII-2C, 802.11ac VHT80, Channel No.: 122



U-NII-2C, 802.11ac VHT80, Channel No.: 138



U-NII-3, 802.11a, Channel No.: 149



U-NII-3, 802.11n HT20, Channel No.: 149

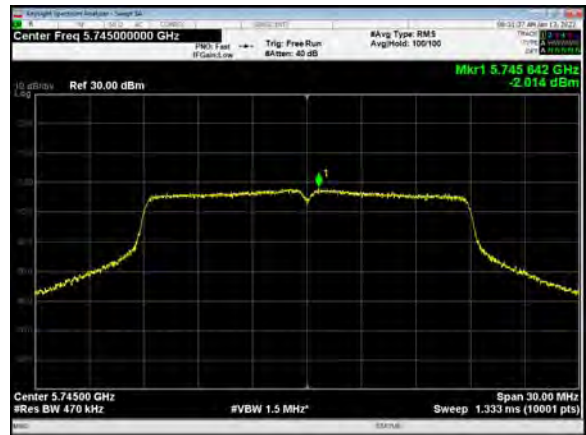

U-NII-3, 802.11a, Channel No.: 157

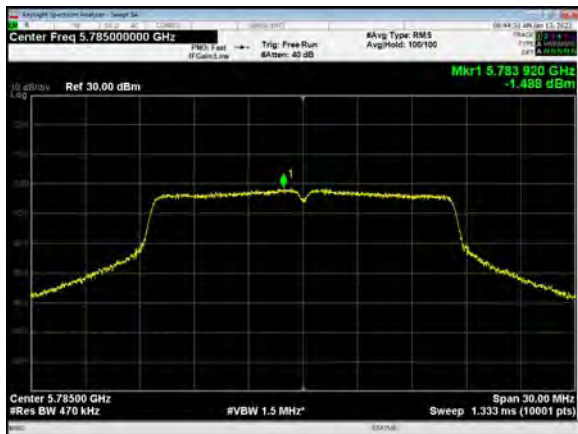

U-NII-3, 802.11n HT20, Channel No.: 157



U-NII-3, 802.11a, Channel No.: 165

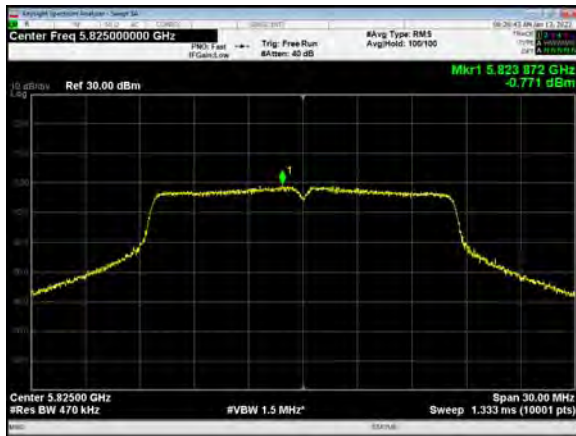

U-NII-3, 802.11n HT20, Channel No.: 165

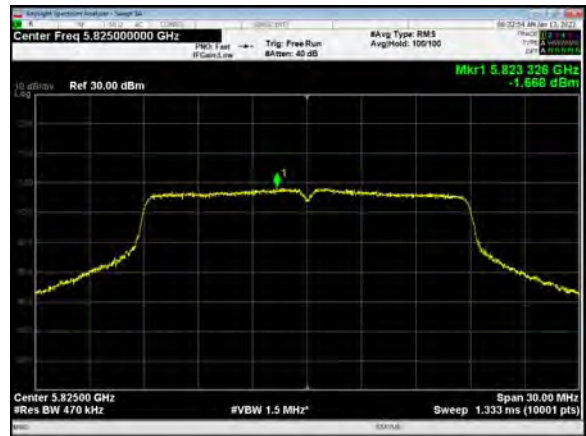

U-NII-3, 802.11n HT40, Channel No.: 151

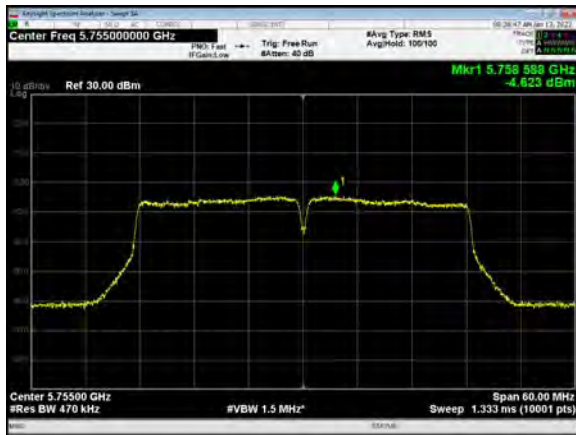

U-NII-3, 802.11ac VHT20, Channel No.: 149

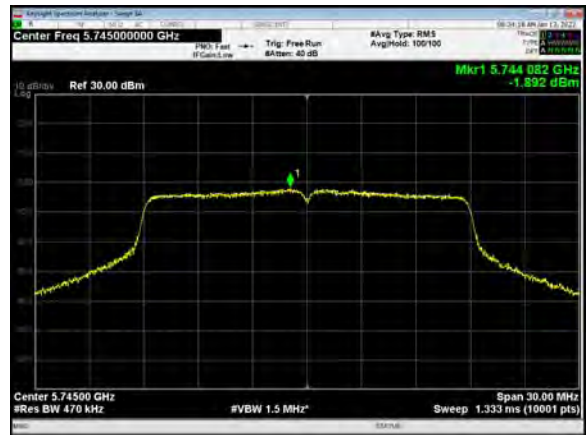

U-NII-3, 802.11n HT40, Channel No.: 159

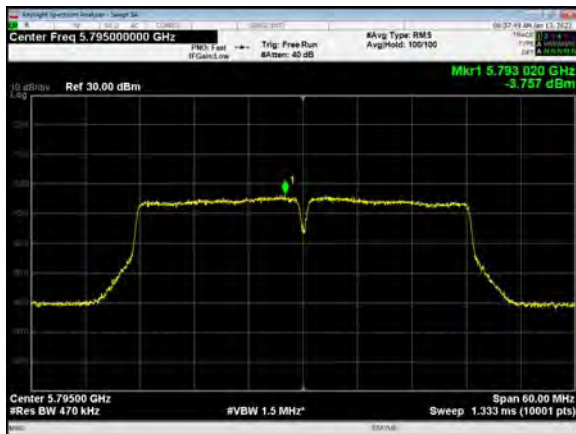

U-NII-3, 802.11ac VHT20, Channel No.: 157

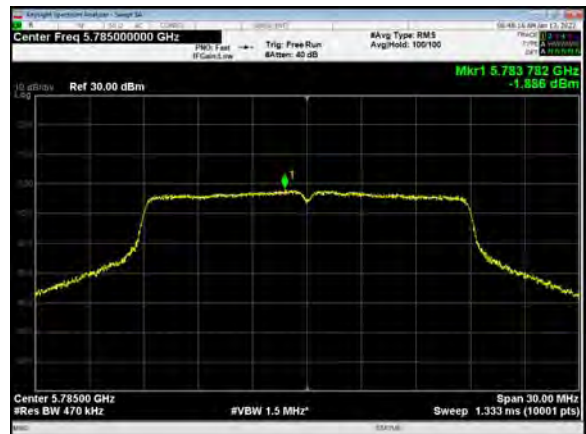



U-NII-3, 802.11ac VHT40, Channel No.: 151

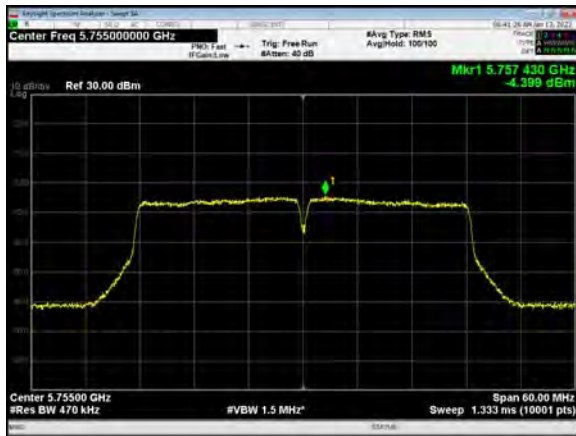

U-NII-3, 802.11ac VHT20, Channel No.: 165

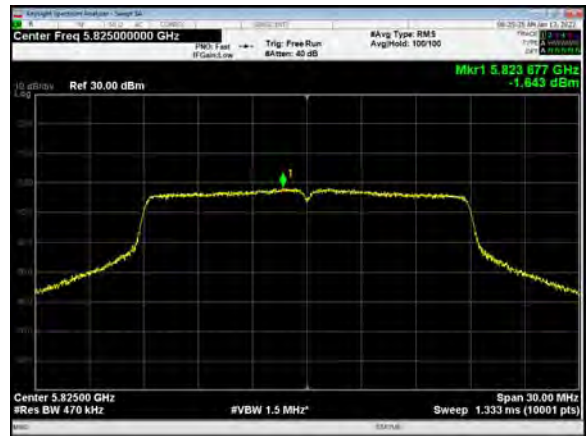

U-NII-3, 802.11ac VHT40, Channel No.: 159

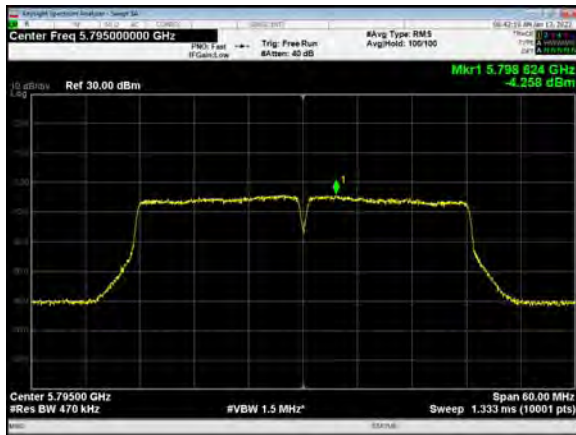

U-NII-3, 802.11ac VHT80, Channel No.: 155

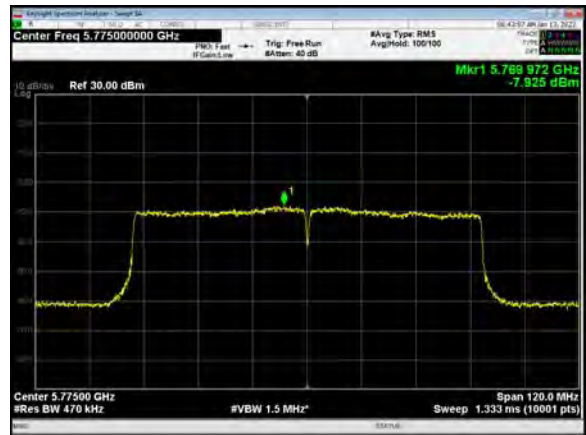

5.5. Unwanted Emission

Ambient condition

Temperature	Relative humidity	Pressure
23°C ~25°C	45%~50%	101.5kPa

Method of Measurement

The test set-up was made in accordance to the general provisions of ANSI C63.10. The Equipment Under Test (EUT) was set up on a non-conductive table in the semi-anechoic chamber. The test was performed at the distance of 3 m between the EUT and the receiving antenna. The radiated emissions measurements were made in a typical installation configuration.

Sweep the whole frequency band range from 9kHz to the 10th harmonic of the carrier, and the emissions less than 20 dB below the permissible value are reported.

During the test, the height of receive antenna shall be moved from 1 to 4 meters, and the antenna shall be performed under horizontal and vertical polarization. The turntable shall be rotated from 0 to 360 degrees for detecting the maximum of radiated spurious signal level. The measurements shall be repeated with orthogonal polarization of the test antenna. The data of cable loss and antenna factor has been calibrated in full testing frequency range before the testing.

Set the spectrum analyzer in the following:

9kHz~150 kHz

RBW=200Hz, VBW=1kHz/ Sweep=AUTO

150 kHz~30MHz

RBW=9KHz, VBW=30KHz,/ Sweep=AUTO

Below 1GHz

RBW=100kHz / VBW=300kHz / Sweep=AUTO

a) Peak emission levels are measured by setting the instrument as follows:

Above 1GHz

PEAK: RBW=1MHz VBW=3MHz/ Sweep=AUTO

b) Average emission levels are measured by setting the instrument as follows:

Above 1GHz

AVERAGE: RBW=1MHz / VBW=3MHz / Sweep=AUTO

c) Detector: The measurements employing a CISPR quasi-peak detector except for the frequency bands 9-90 kHz, 110-490 kHz and above 1000 MHz. Radiated emission limits in these three bands are based on measurements employing an average detector.

d) Averaging type = power (i.e., rms) (As an alternative, the detector and averaging type may be set for linear voltage averaging. Some instruments require linear display mode to use linear voltage averaging. Log or dB averaging shall not be used.)

e) Sweep time = auto.

f) Perform a trace average of at least 100 traces if the transmission is continuous. If the transmission is not continuous, then the number of traces shall be increased by a factor of $1 / D$, where D is the duty cycle. For example, with 50% duty cycle, at least 200 traces shall be averaged. (If a specific



emission is demonstrated to be continuous—i.e., 100% duty cycle—then rather than turning ON and OFF with the transmit cycle, at least 100 traces shall be averaged.)

g) If tests are performed with the EUT transmitting at a duty cycle less than 98%, then a correction factor shall be added to the measurement results prior to comparing with the emission limit, to compute the emission level that would have been measured had the test been performed at 100% duty cycle. The correction factor is computed as follows:

1) If power averaging (rms) mode was used in the preceding step e), then the correction factor is $[10 \log (1 / D)]$, where D is the duty cycle. For example, if the transmit duty cycle was 50%, then 3 dB shall be added to the measured emission levels.

2) If linear voltage averaging mode was used in the preceding step e), then the correction factor is $[20 \log (1 / D)]$, where D is the duty cycle. For example, if the transmit duty cycle was 50%, then 6 dB shall be added to the measured emission levels.

3) If a specific emission is demonstrated to be continuous (100% duty cycle) rather than turning ON and OFF with the transmit cycle, then no duty cycle correction is required for that emission.

Reduce the video bandwidth until no significant variations in the displayed signal are observed in subsequent traces, provided the video bandwidth is no less than 1 Hz. For regulatory requirements that specify averaging only over the transmit duration (e.g., digital transmission system [DTS] and Unlicensed National Information Infrastructure [U-NII]), the video bandwidth shall be greater than $[1 / (\text{minimum transmitter on time})]$ and no less than 1 Hz.

The field strength of spurious emission was measured in the following position: EUT stand-up position (Z axis), lie-down position (X, Y axis). The worst emission was found in stand-up position (Z axis) and the loop antenna is vertical, others antenna are vertical and horizontal.

The test is in transmitting mode.

9KHz~~~30MHz

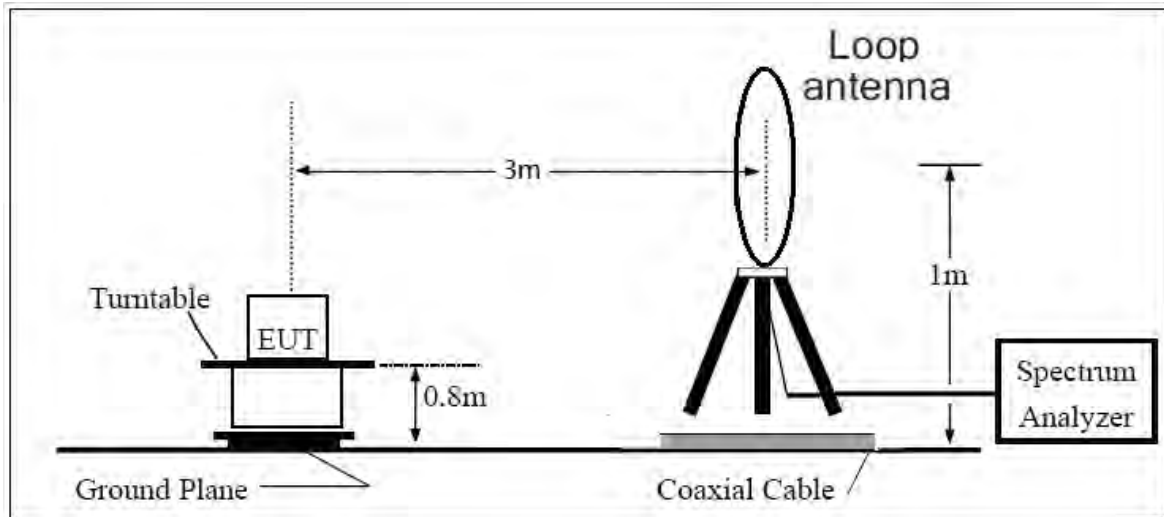

30MHz~~~ 1GHz

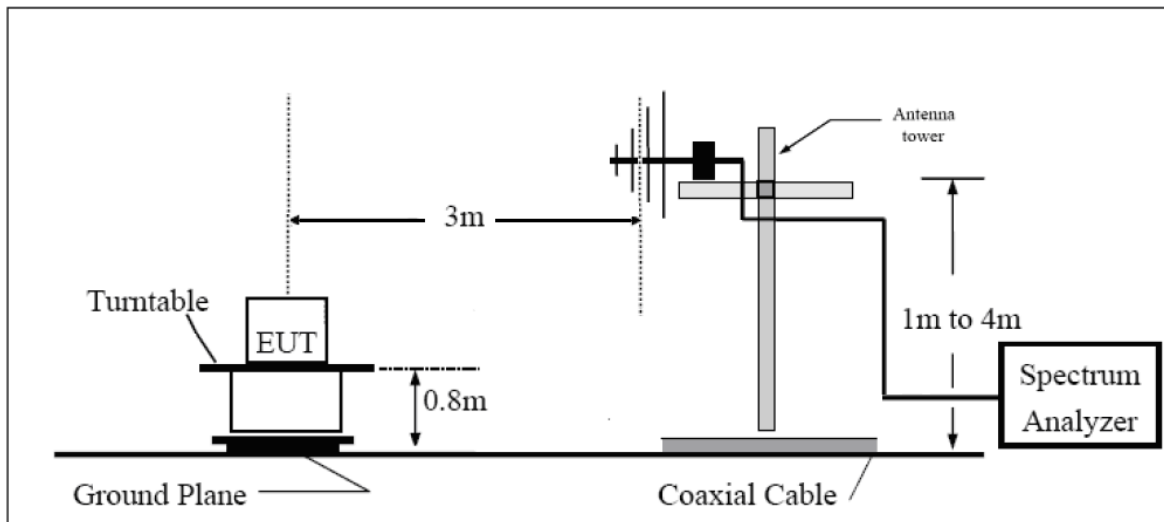

Above 1GHz

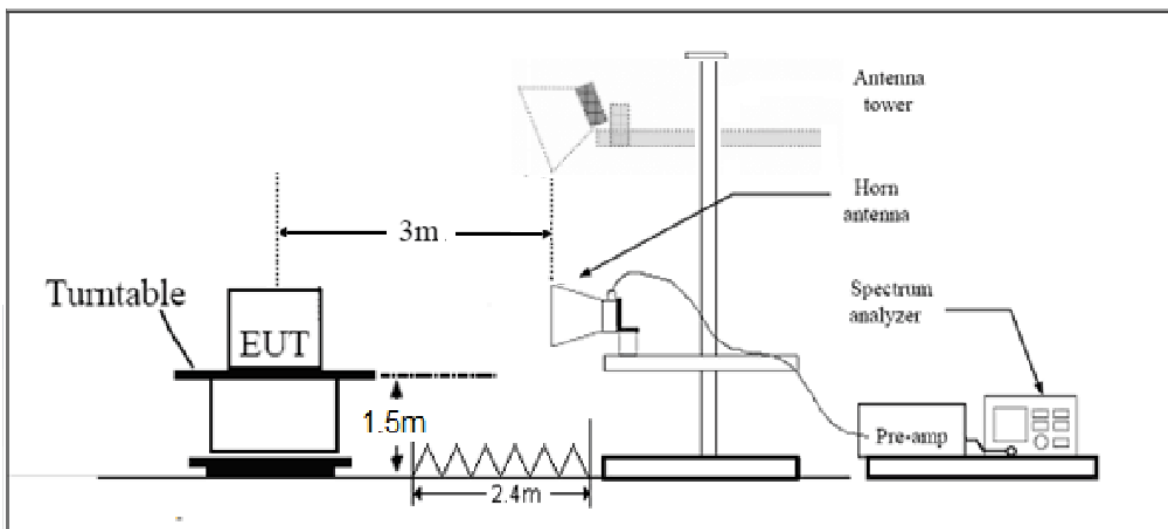

Note: Area side:2.4mX3.6m

Limits

- (1) For transmitters operating in the 5725-5850 MHz band: All emissions shall be limited to a level of -27 dBm/MHz at 75 MHz or more above or below the band edge increasing linearly to 10 dBm/MHz at 25 MHz above or below the band edge, and from 25 MHz above or below the band edge increasing linearly to a level of 15.6 dBm/MHz at 5 MHz above or below the band edge, and from 5 MHz above or below the band edge increasing linearly to a level of 27 dBm/MHz at the band edge.
- (2) For transmitters operating in the 5.15-5.25 GHz band: All emissions outside of the 5.15-5.35 GHz band shall not exceed an e.i.r.p. of -27 dBm/MHz(68.2dBμV/m).
- (3) For transmitters operating in the 5.25-5.35 GHz band: All emissions outside of the 5.15-5.35 GHz band shall not exceed an e.i.r.p. of -27 dBm/MHz(68.2dBμV/m).
- (4) For transmitters operating in the 5.47-5.725 GHz band: All emissions outside of the 5.47-5.725 GHz band shall not exceed an e.i.r.p. of -27 dBm/MHz(68.2dBμV/m).

Note: the following formula is used to convert the EIRP to field strength

§1、 $E[\text{dB}\mu\text{V}/\text{m}] = \text{EIRP}[\text{dBm}] - 20 \log(d[\text{meters}]) + 104.77$, where E = field strength and

d = distance at which field strength limit is specified in the rules;

§2、 $E[\text{dB}\mu\text{V}/\text{m}] = \text{EIRP}[\text{dBm}] + 95.2$, for d = 3 meters

- (5) Unwanted spurious emissions fallen in restricted bands per FCC Part15.205 shall comply with the general field strength limits set forth in § 15.209 as below table.

Frequency of emission (MHz)	Field strength(uV/m)	Field strength(dBuV/m)
0.009–0.490	2400/F(kHz)	/
0.490–1.705	24000/F(kHz)	/
1.705–30.0	30	/
30-88	100	40
88-216	150	43.5
216-960	200	46
Above960	500	54



MHz	MHz	MHz	GHz
0.090 - 0.110	16.42 - 16.423	399.9 - 410	4.5 - 5.15
0.495 - 0.505	16.69475 - 16.69525	608 - 614	5.35 - 5.46
2.1735 - 2.1905	16.80425 - 16.80475	960 - 1240	7.25 - 7.75
4.125 - 4.128	25.5 - 25.67	1300 - 1427	8.025 - 8.5
4.17725 - 4.17775	37.5 - 38.25	1435 - 1626.5	9.0 - 9.2
4.20725 - 4.20775	73 - 74.6	1645.5 - 1646.5	9.3 - 9.5
6.215 - 6.218	74.8 - 75.2	1660 - 1710	10.6 - 12.7
6.26775 - 6.26825	108 - 121.94	1718.8 - 1722.2	13.25 - 13.4
6.31175 - 6.31225	123 - 138	2200 - 2300	14.47 - 14.5
8.291 - 8.294	149.9 - 150.05	2310 - 2390	15.35 - 16.2
8.362 - 8.366	156.52475 - 156.52525	2483.5 - 2500	17.7 - 21.4
8.37625 - 8.38675	156.7 - 156.9	2690 - 2900	22.01 - 23.12
8.41425 - 8.41475	162.0125 - 167.17	3260 - 3267	23.6 - 24.0
12.29 - 12.293	167.72 - 173.2	3332 - 3339	31.2 - 31.8
12.51975 - 12.52025	240 - 285	3345.8 - 3358	36.43 - 36.5
12.57675 - 12.57725	322 - 335.4	3600 - 4400	(²)
13.36 - 13.41			

Measurement Uncertainty

The assessed measurement uncertainty to ensure 95% confidence level for the normal distribution is with the coverage factor $k = 1.96$.

Frequency	Uncertainty
9KHz-30MHz	3.55 dB
30MHz-200MHz	4.17 dB
200MHz-1GHz	4.84 dB
1-18GHz	4.35 dB
18-26.5GHz	5.90 dB
26.5GHz~40GHz	5.92 dB



Test Results:

The modulation and bandwidth are similar for 802.11n mode for 20MHz/40MHz and 802.11ac mode for V20MHz/V40MHz, therefore investigated worst case to representative mode in test report.

Note: A font (Level in dB μ V/m) in the test plot =(level in dB μ V/m)

A font (dB μ V/m) in the test plot =(dB μ V/m)

The signal beyond the limit is carrier.

U-NII-1

802.11a-Channel 36: Peak + Average

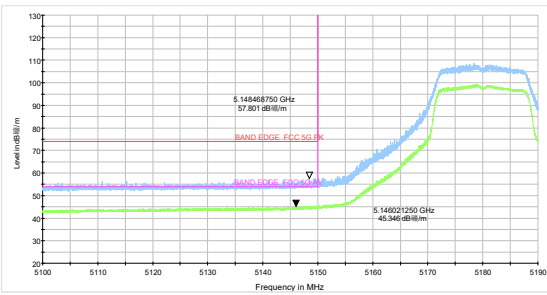

802.11a-Channel 48: Peak + Average

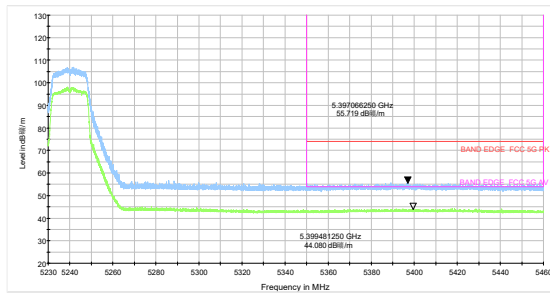

802.11n HT20 -Channel 36: Peak + Average

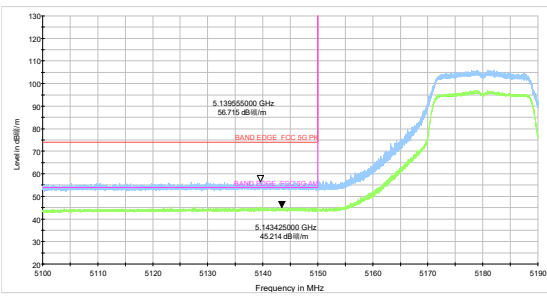

802.11n HT20 -Channel 48: Peak + Average

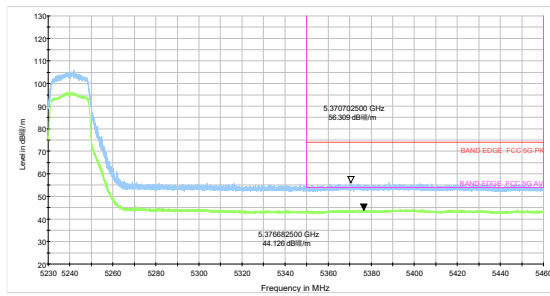

802.11n HT40-Channel 38: Peak + Average

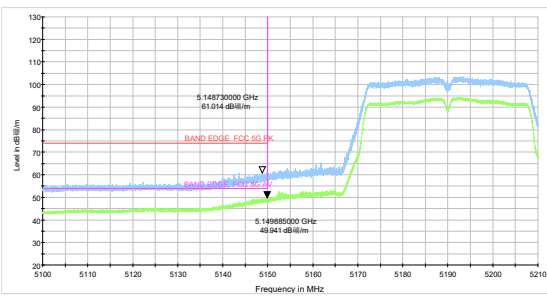

802.11n HT40-Channel 46: Peak + Average

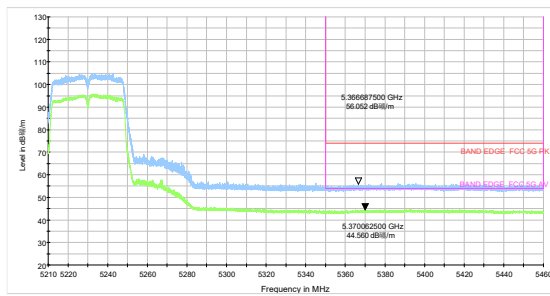

802.11ac VHT80 -Channel 42: Peak + Average

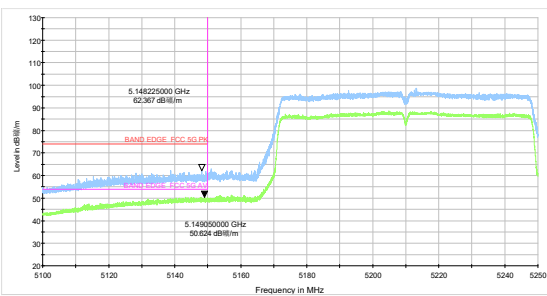



U-NII-2A

802.11a-Channel 52: Peak + Average

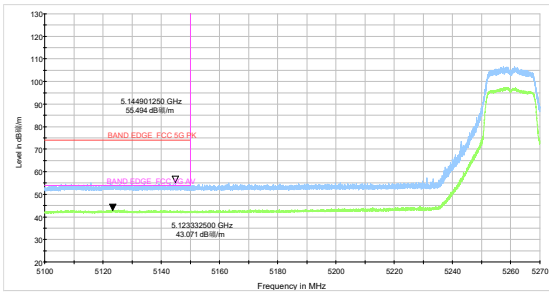

802.11a-Channel 64: Peak + Average

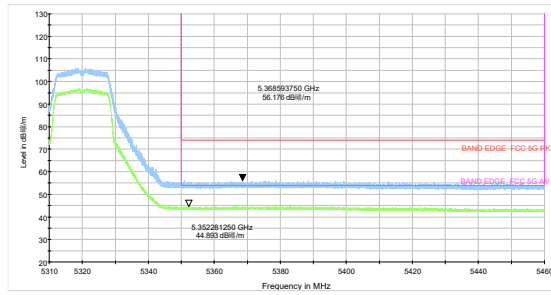

802.11n HT20 -Channel 52: Peak + Average

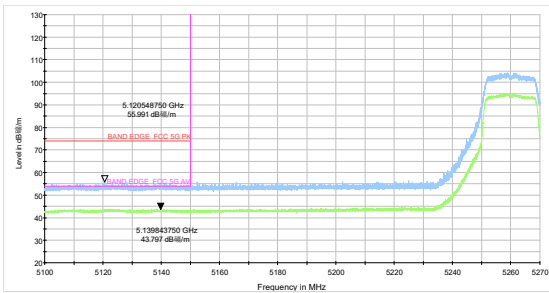

802.11n HT20 -Channel 64: Peak + Average

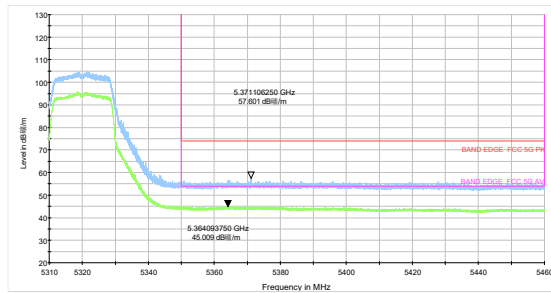

802.11n HT40-Channel 54: Peak + Average

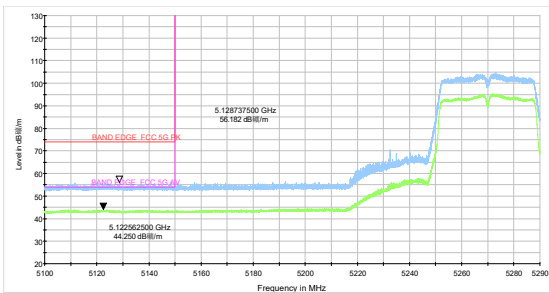

802.11n HT40-Channel 62: Peak + Average

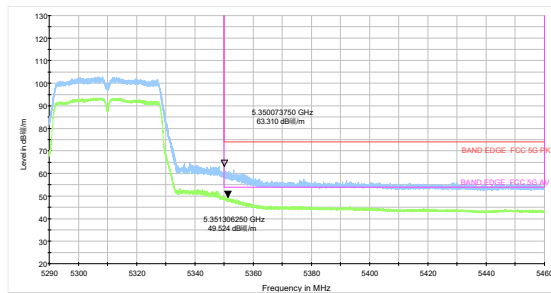

802.11ac VHT80 -Channel 58: Peak + Average

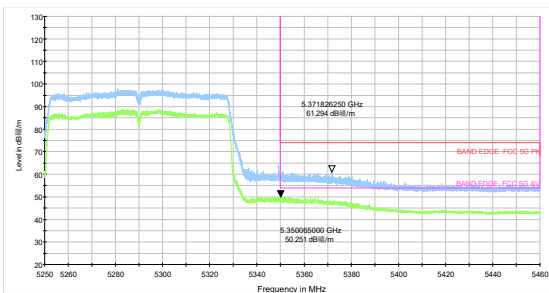



U-NII-2C

802.11a-Channel 100: Peak + Average

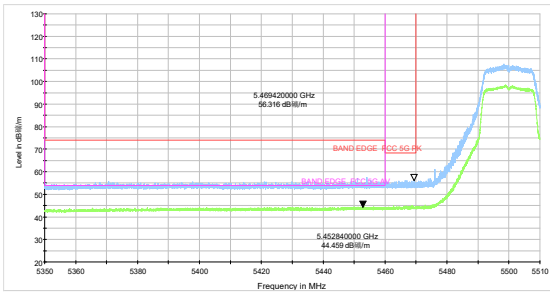

802.11n HT20 -Channel 100: Peak + Average

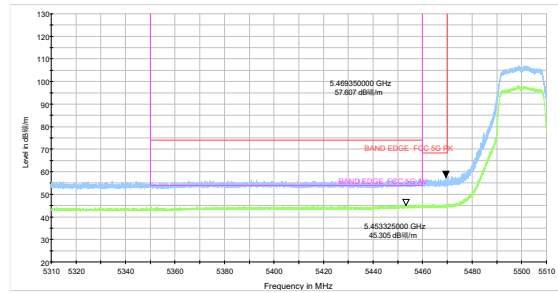

802.11a-Channel 140: Peak

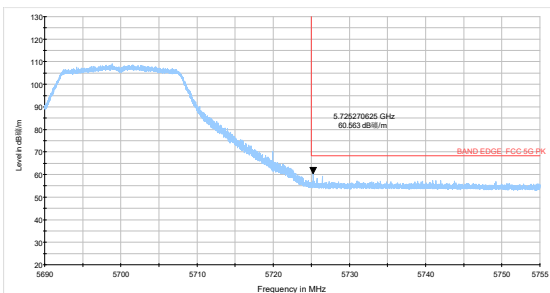

802.11n HT20 -Channel 140: Peak

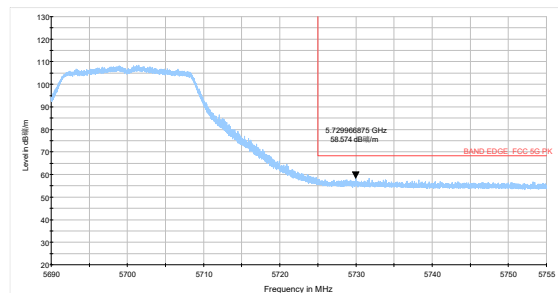

802.11a-Channel 144: Peak

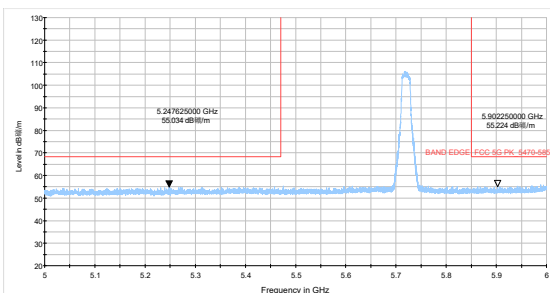

802.11n HT20-Channel 144: Peak

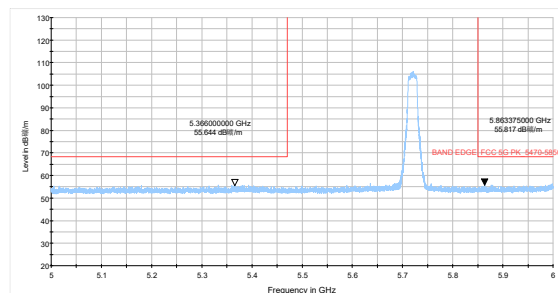

802.11n HT40-Channel 102: Peak + Average

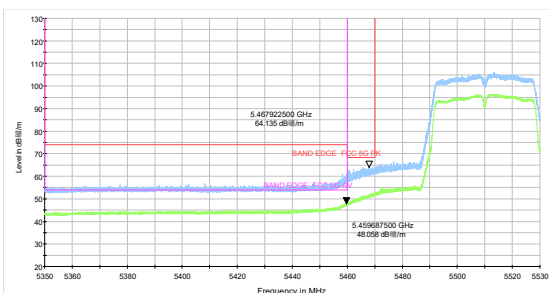

802.11n HT40-Channel 134: Peak

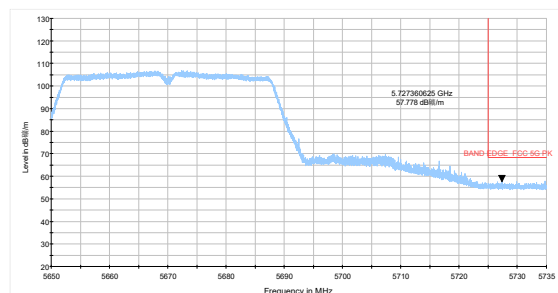



802.11n HT40-Channel 142: Peak

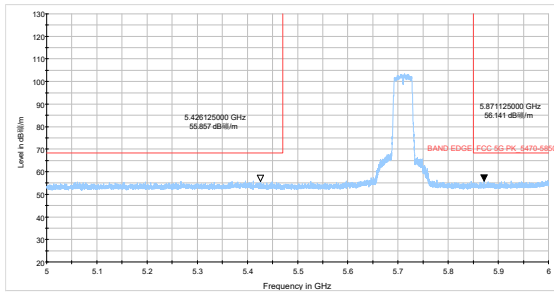

802.11ac VHT80-Channel 106: Peak

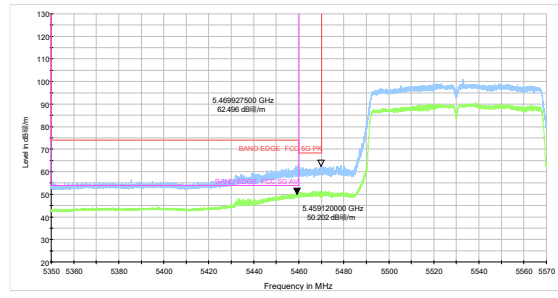

802.11ac VHT80-Channel 138: Peak

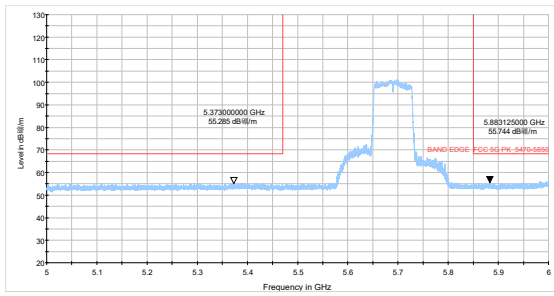

802.11ac VHT80-Channel 122: Peak

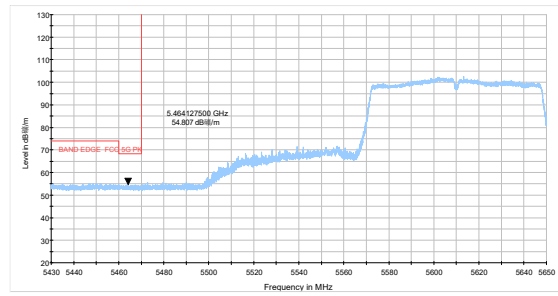



U-NII-3

802.11a-Channel 149: Peak

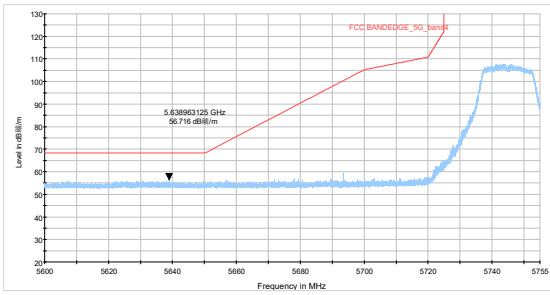

802.11a-Channel 165: Peak

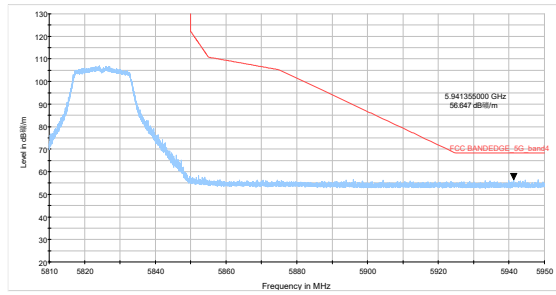

802.11n HT20-Channel 149: Peak

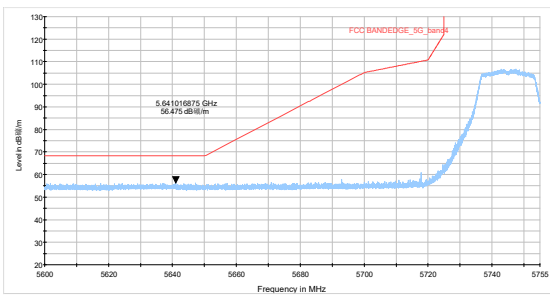

802.11n HT20-Channel 165: Peak

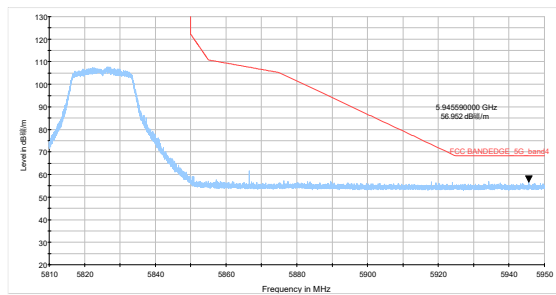

802.11n HT40-Channel 151: Peak

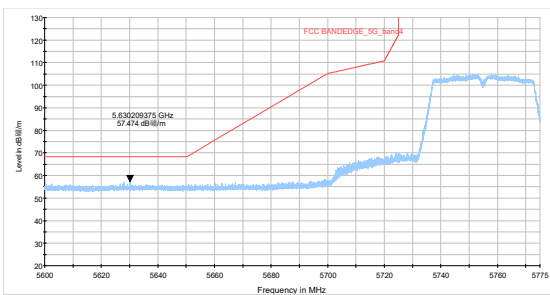

802.11n HT40-Channel 159: Peak

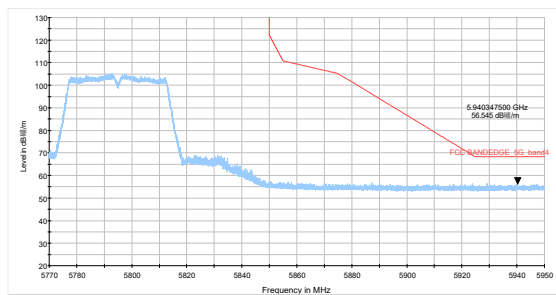

802.11ac VHT80- Channel 155: Peak

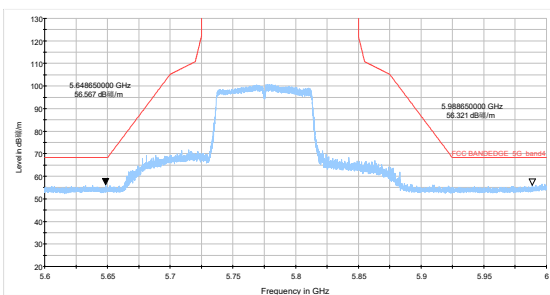



Result of RE

Test result

Sweep the whole frequency band through the range from 9kHz to the 10th harmonic of the carrier, the Emissions in the frequency band 9kHz-30MHz and 26.5GHz-40GHz are more than 20dB below the limit are not reported.

Note: A font (Level in dB μ V/m)in the test plot =(level in dB μ V/m)

A font (Level in dB μ V/)in the test plot =(level in dB μ V/m)

During the test, the Radiates Emission from 30MHz to 1GHz was performed in all modes with all channels, 802.11n (HT20), Channel 48 are selected as the worst condition. The test data of the worst-case condition was recorded in this report.

Continuous TX mode:

FCC RE 9K-90KHz AV

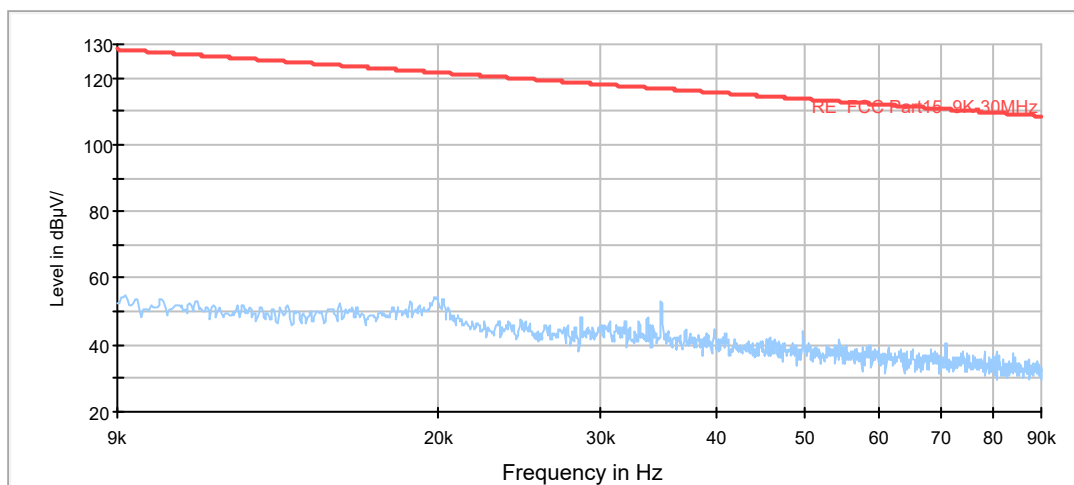

Radiates Emission from 9KHz to 90KHz

FCC RE 90K-110KHz QP

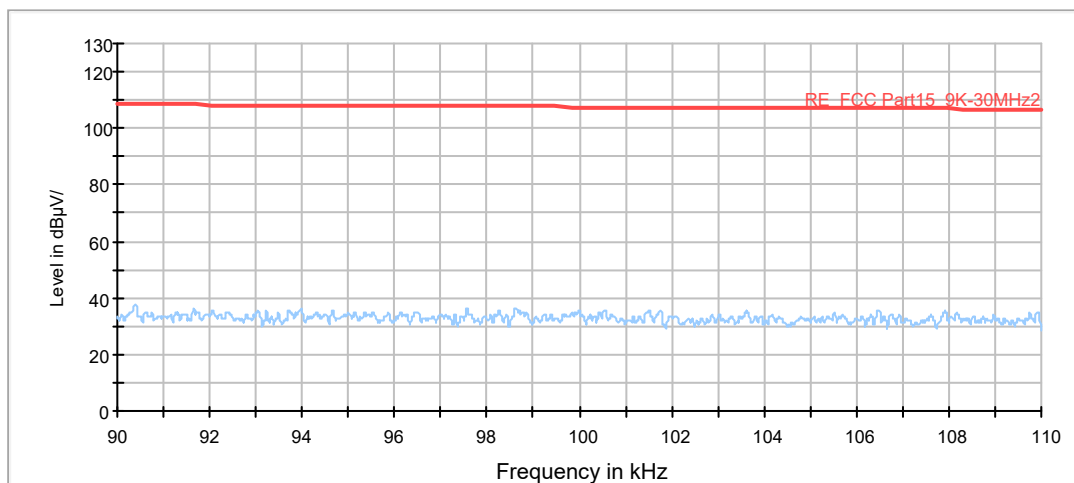

Radiates Emission from 90KHz to 110KHz



FCC RE 110K-490KHz AV

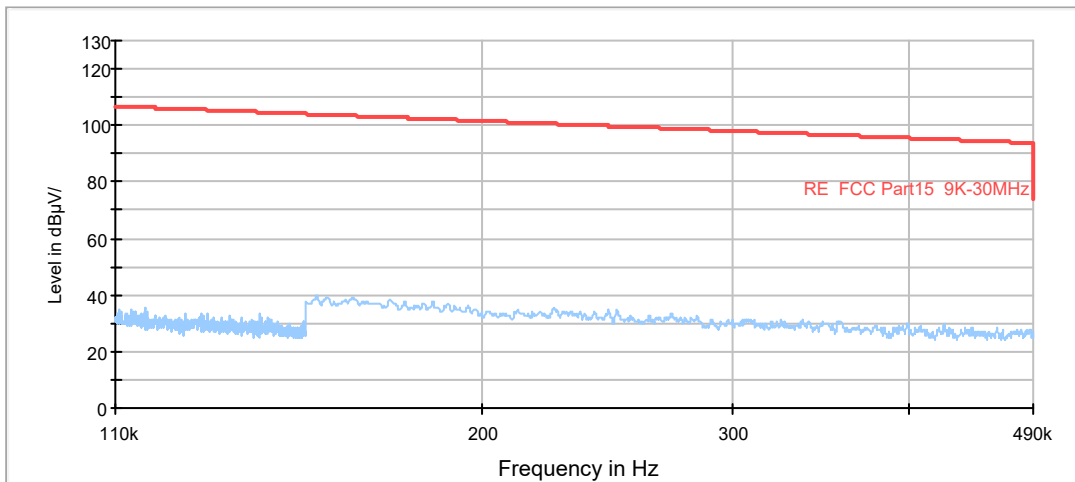

Radiates Emission from 110KHz to 490KHz

FCC RE 490K-30MHz QP

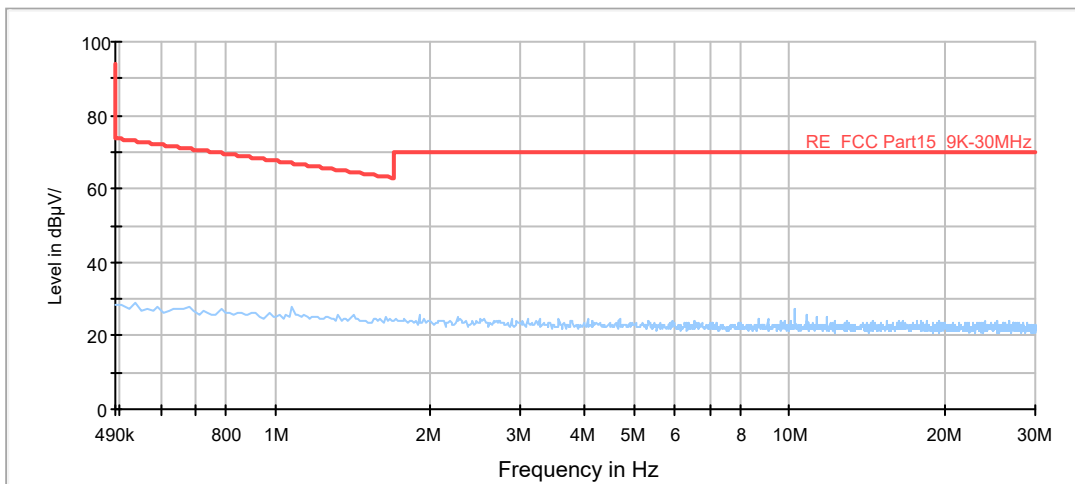

Radiates Emission from 490KHz to 30MHz

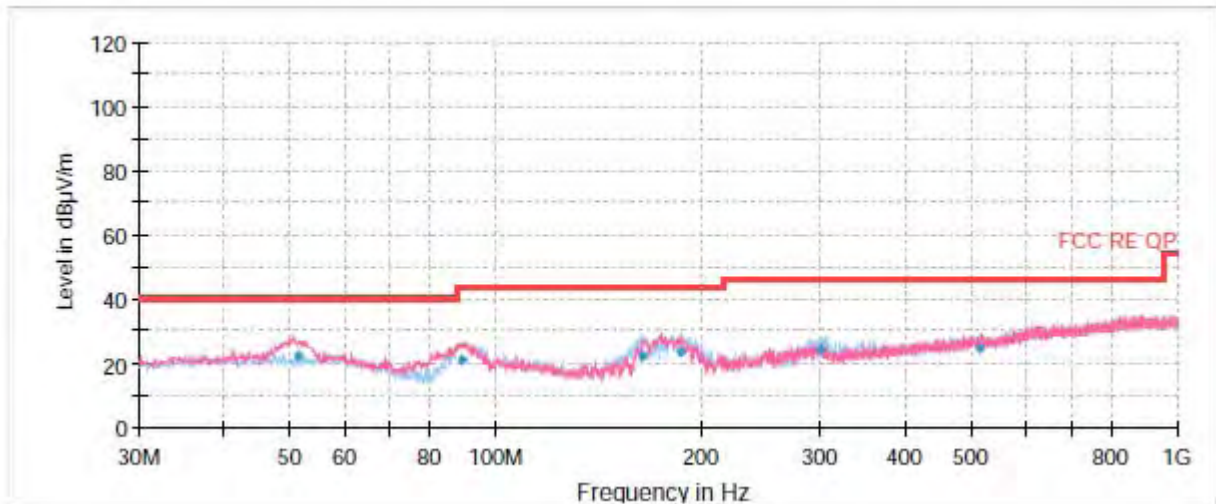

Radiates Emission from 30MHz to 1GHz

Frequency (MHz)	Quasi-Peak (dBuV/m)	Height (cm)	Polarization	Azimuth (deg)	Correct Factor (dB)	Margin (dB)	Limit (dBuV/m)
51.253750	22.18	100.0	V	296.0	14	17.82	40.00
88.996250	21.22	105.0	V	52.0	11	22.28	43.50
164.255000	21.98	192.0	H	250.0	10	21.52	43.50
186.256250	23.19	175.0	H	48.0	12	20.31	43.50
299.343750	24.05	100.0	H	251.0	15	21.95	46.00
513.906250	24.55	225.0	H	304.0	20	21.45	46.00

Remark: 1. Correction Factor = Antenna factor+ Insertion loss(cable loss+amplifier gain)

2. Margin = Limit – Quasi-Peak

802.11a CH36

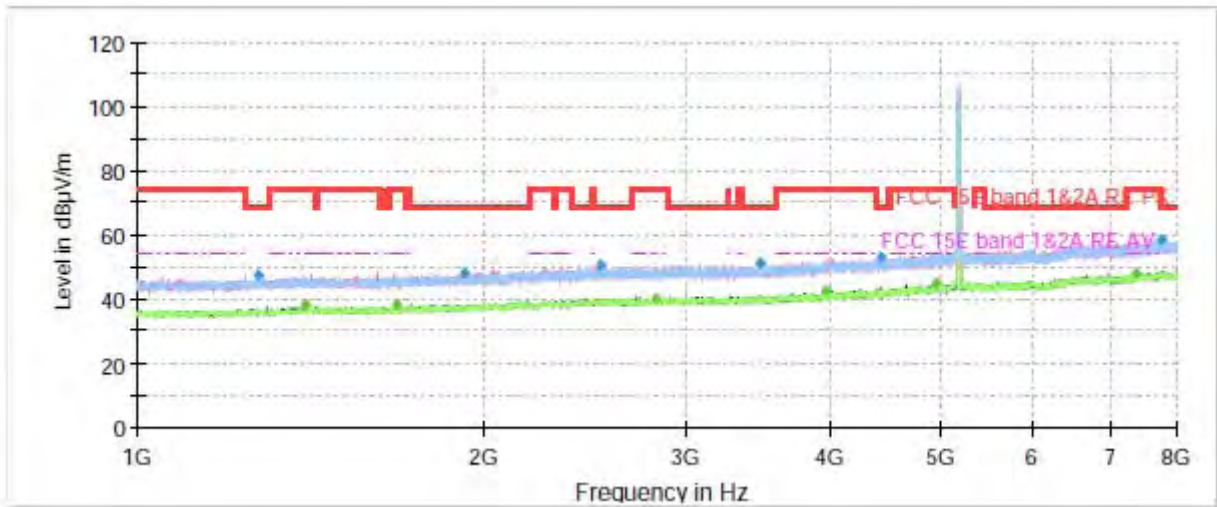

Note: The signal beyond the limit is carrier.
Radiates Emission from 1GHz to 8GHz

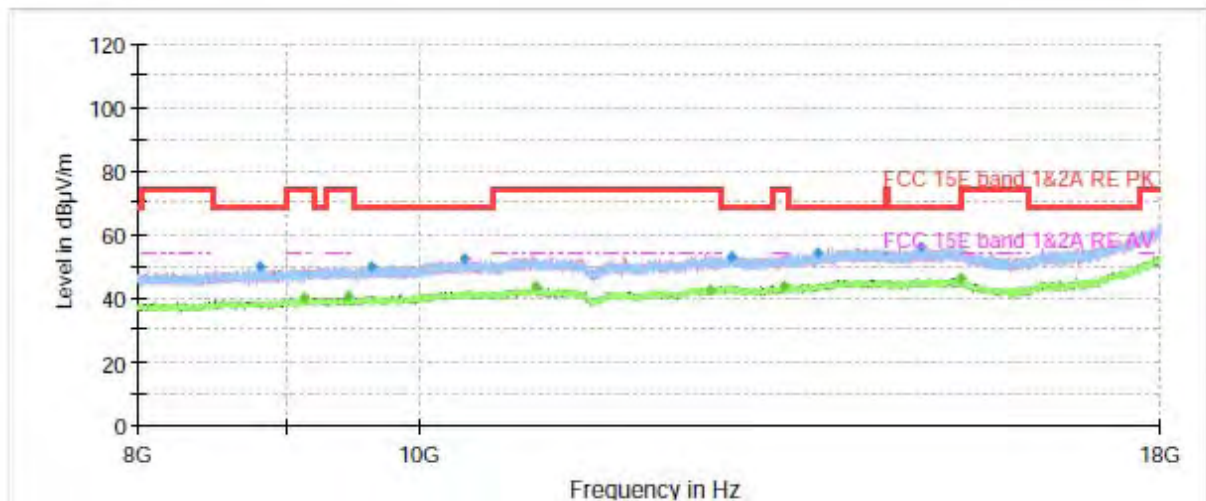

Radiates Emission from 8GHz to 18GHz



Frequency (MHz)	Peak (dBuV/m)	Average (dBuV/m)	Limit (dBuV/m)	Margin (dB)	Height (cm)	Polarization	Azimuth (deg)	Correct Factor (dB)
1271.600000	47.17	---	68.20	21.03	200.0	H	6.0	-8
1400.633333	---	37.86	54.00	16.14	200.0	V	358.0	-7
1677.600000	---	37.86	54.00	16.14	200.0	H	158.0	-6
1921.200000	48.10	---	68.20	20.10	200.0	V	306.0	-5
2528.333333	50.17	---	68.20	18.03	200.0	V	120.0	-4
2824.200000	---	40.30	54.00	13.70	200.0	V	51.0	-3
3481.033333	50.96	---	68.20	17.24	100.0	H	356.0	-3
3959.133333	---	42.25	54.00	11.75	100.0	H	320.0	-1
4422.533333	52.89	---	68.20	15.31	200.0	V	348.0	0
4955.000000	---	44.91	54.00	9.09	200.0	H	11.0	2
7380.266667	---	48.31	54.00	5.69	200.0	H	39.0	7
7775.300000	58.73	---	68.20	9.47	100.0	V	1.0	7

Remark: 1. Correction Factor = Antenna factor+ Insertion loss (cable loss + amplifier gain)

802.11a CH40

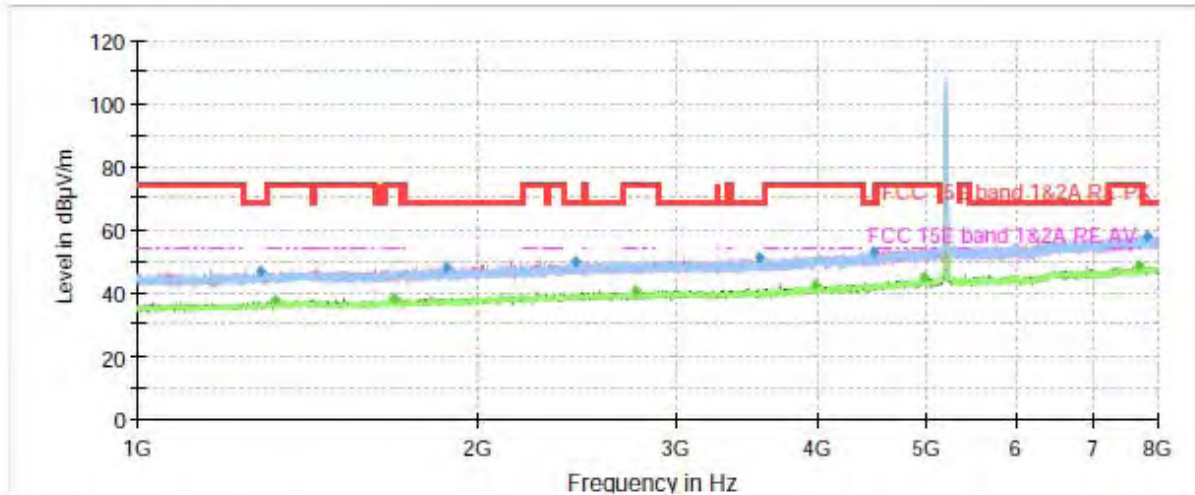

Note: The signal beyond the limit is carrier.
Radiates Emission from 1GHz to 8GHz

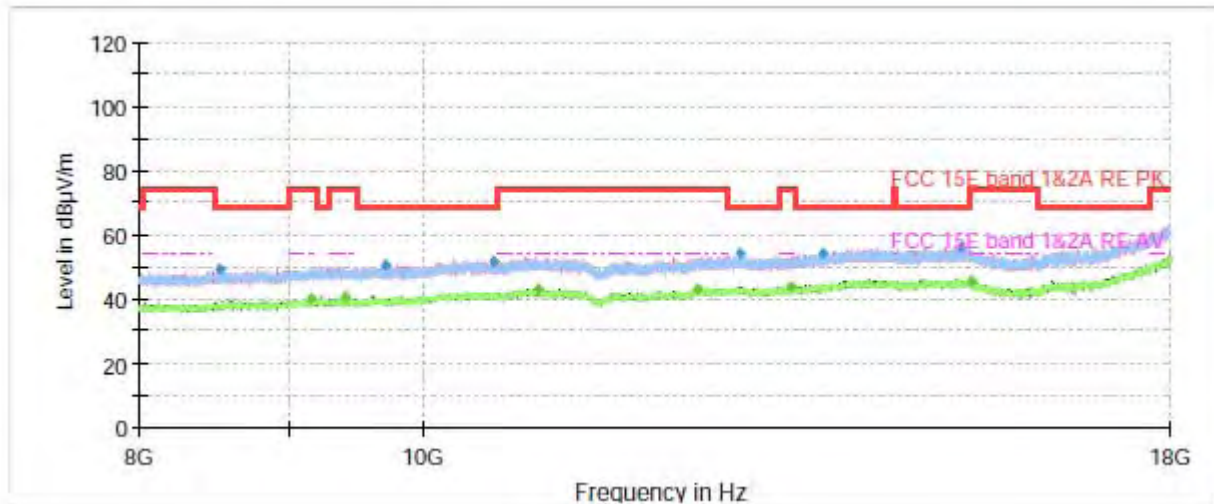

Radiates Emission from 8GHz to 18GHz



Frequency (MHz)	Peak (dBuV/m)	Average (dBuV/m)	Limit (dBuV/m)	Margin (dB)	Height (cm)	Polarization	Azimuth (deg)	Correct Factor (dB)
1287.000000	46.60	---	68.20	21.60	100.0	H	199.0	-8
1325.266667	---	37.34	54.00	16.66	100.0	V	279.0	-8
1690.433333	---	37.90	54.00	16.10	200.0	V	0.0	-6
1873.833333	48.06	---	68.20	20.14	200.0	H	197.0	-5
2437.333333	49.79	---	68.20	18.41	100.0	H	51.0	-4
2766.566667	---	40.45	54.00	13.55	100.0	V	132.0	-4
3548.466667	50.86	---	68.20	17.34	200.0	V	0.0	-3
3982.933333	---	42.31	54.00	11.69	200.0	V	334.0	-1
4480.166667	52.68	---	68.20	15.52	100.0	V	238.0	0
4969.233333	---	44.79	54.00	9.21	100.0	V	106.0	2
7713.700000	---	48.36	54.00	5.64	200.0	H	93.0	7
7822.900000	58.15	---	68.20	10.05	100.0	H	358.0	7

Remark: 1. Correction Factor = Antenna factor+ Insertion loss (cable loss + amplifier gain)

802.11a CH48

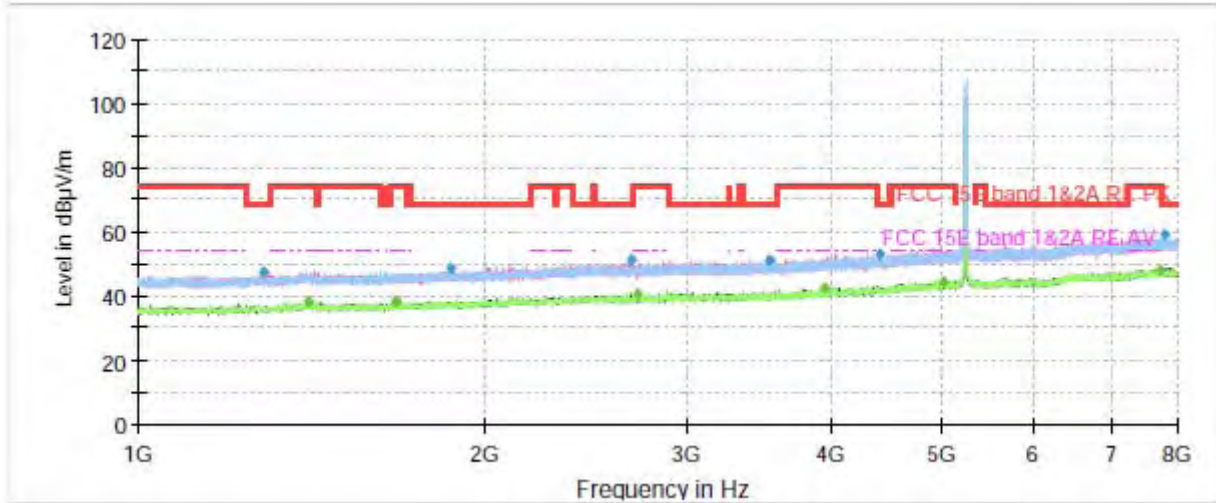

Note: The signal beyond the limit is carrier.
Radiates Emission from 1GHz to 8GHz

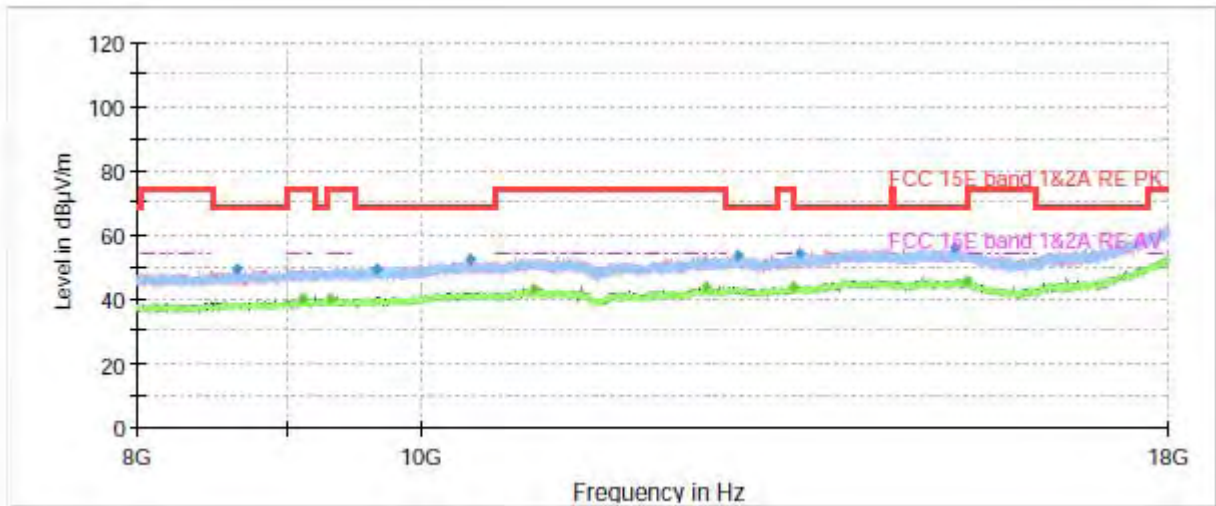

Radiates Emission from 8GHz to 18GHz



Frequency (MHz)	Peak (dBuV/m)	Average (dBuV/m)	Limit (dBuV/m)	Margin (dB)	Height (cm)	Polarization	Azimuth (deg)	Correct Factor (dB)
1286.533333	47.40	---	68.20	20.80	100.0	V	157.0	-8
1403.200000	---	38.08	54.00	15.92	100.0	V	0.0	-7
1672.233333	---	38.13	54.00	15.87	200.0	V	179.0	-6
1868.933333	48.70	---	68.20	19.50	200.0	H	105.0	-5
2678.133333	51.01	---	68.20	17.19	100.0	V	39.0	-3
2719.900000	---	40.31	54.00	13.69	200.0	H	158.0	-4
3530.266667	50.78	---	68.20	17.42	200.0	V	311.0	-3
3950.266667	---	42.46	54.00	11.54	100.0	V	3.0	-1
4416.933333	53.13	---	68.20	15.07	200.0	V	0.0	0
5018.933333	---	44.56	54.00	9.44	100.0	V	77.0	2
7729.100000	---	48.27	54.00	5.73	100.0	H	350.0	7
7807.033333	59.17	---	68.20	9.03	200.0	H	158.0	7

Remark: 1. Correction Factor = Antenna factor+ Insertion loss (cable loss + amplifier gain)

802.11a CH52

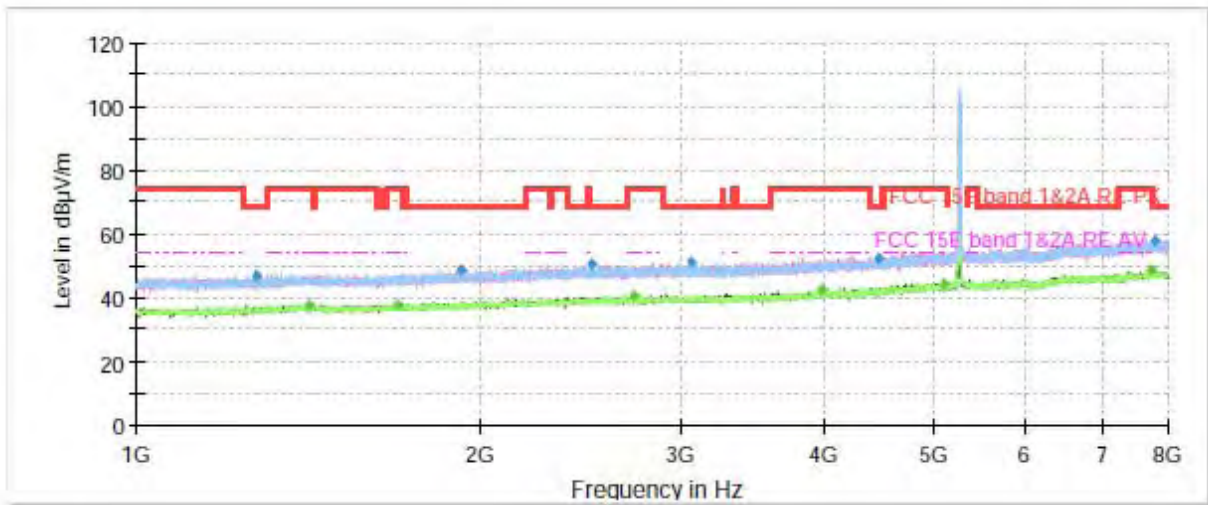

Note: The signal beyond the limit is carrier.
Radiates Emission from 1GHz to 8GHz

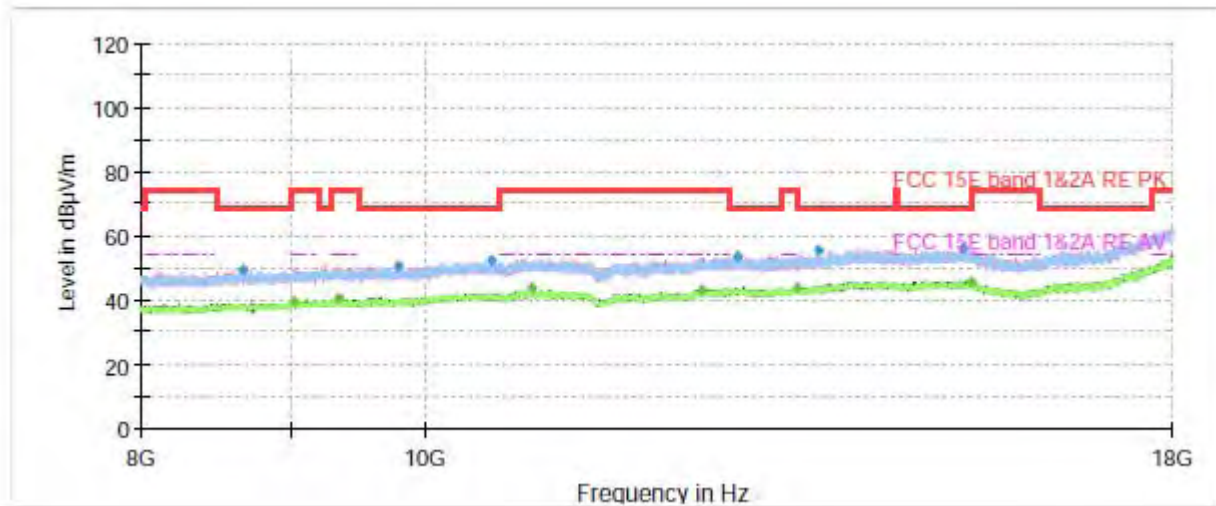

Radiates Emission from 8GHz to 18GHz



Frequency (MHz)	Peak (dBuV/m)	Average (dBuV/m)	Limit (dBuV/m)	Margin (dB)	Height (cm)	Polarization	Azimuth (deg)	Correct Factor (dB)
1276.966667	46.55	---	68.20	21.65	100.0	H	254.0	-8
1417.666667	---	37.82	54.00	16.18	100.0	V	198.0	-7
1695.566667	---	37.66	54.00	16.34	100.0	H	214.0	-6
1924.466667	48.68	---	68.20	19.52	200.0	H	62.0	-5
2506.400000	50.24	---	68.20	17.96	100.0	V	6.0	-4
2723.166667	---	40.42	54.00	13.58	200.0	H	88.0	-4
3053.566667	51.08	---	68.20	17.12	200.0	H	62.0	-3
3986.200000	---	42.22	54.00	11.78	200.0	V	313.0	-1
4474.800000	52.55	---	68.20	15.65	100.0	H	214.0	0
5090.100000	---	44.39	54.00	9.61	100.0	H	341.0	2
7748.233333	---	48.72	54.00	5.28	100.0	V	18.0	7
7814.033333	58.01	---	68.20	10.19	100.0	V	79.0	7

Remark: 1. Correction Factor = Antenna factor+ Insertion loss (cable loss + amplifier gain)

802.11a CH60

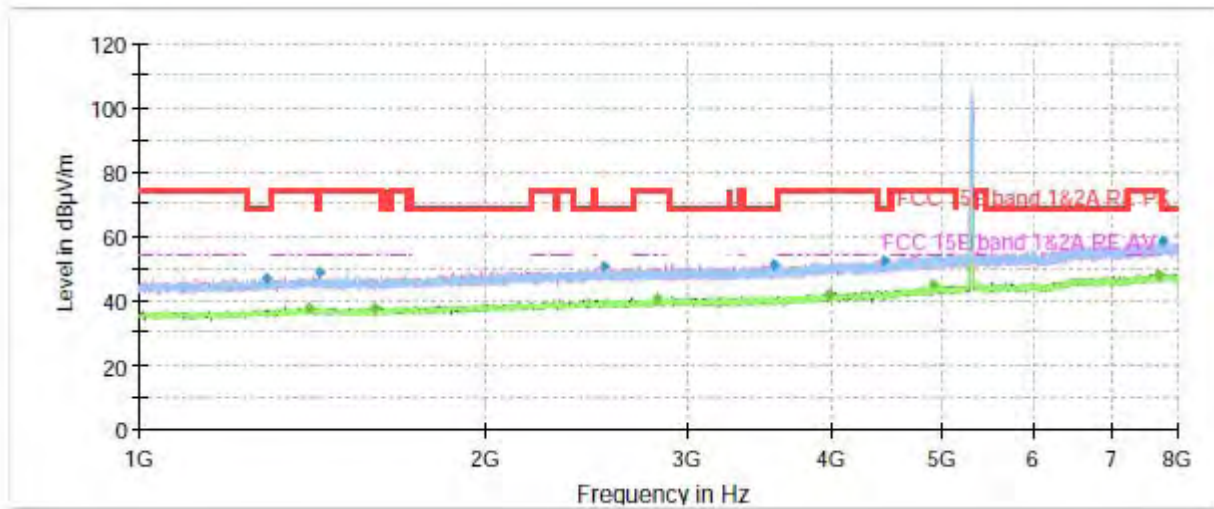

Note: The signal beyond the limit is carrier.
Radiates Emission from 1GHz to 8GHz

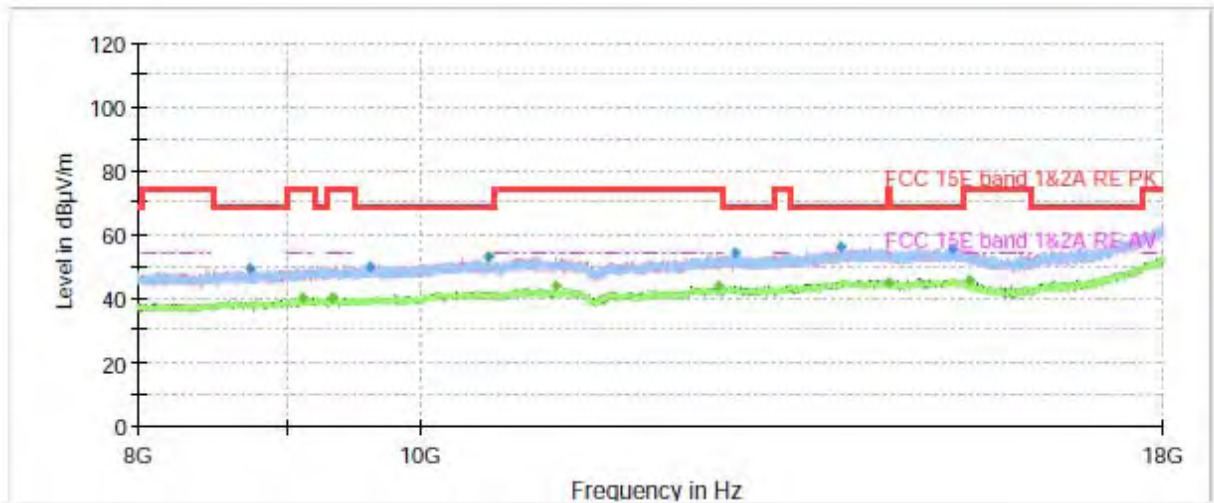

Radiates Emission from 8GHz to 18GHz



Frequency (MHz)	Peak (dBuV/m)	Average (dBuV/m)	Limit (dBuV/m)	Margin (dB)	Height (cm)	Polarization	Azimuth (deg)	Correct Factor (dB)
1290.733333	46.76	---	68.20	21.44	200.0	H	3.0	-8
1402.966667	---	37.51	54.00	16.49	100.0	H	51.0	-7
1434.233333	48.86	---	68.20	19.34	200.0	V	245.0	-7
1602.233333	---	37.79	54.00	16.21	100.0	V	1.0	-6
2540.700000	50.49	---	68.20	17.71	100.0	V	184.0	-4
2827.933333	---	40.46	54.00	13.54	100.0	V	64.0	-3
3566.433333	51.09	---	68.20	17.11	100.0	V	0.0	-3
3986.433333	---	42.15	54.00	11.85	100.0	V	0.0	-1
4448.666667	52.53	---	68.20	15.67	100.0	V	294.0	0
4908.566667	---	44.99	54.00	9.01	200.0	V	271.0	2
7691.766667	---	48.18	54.00	5.82	200.0	V	0.0	7
7764.800000	58.19	---	68.20	10.01	200.0	V	356.0	7

Remark: 1. Correction Factor = Antenna factor+ Insertion loss (cable loss + amplifier gain)

802.11a CH64

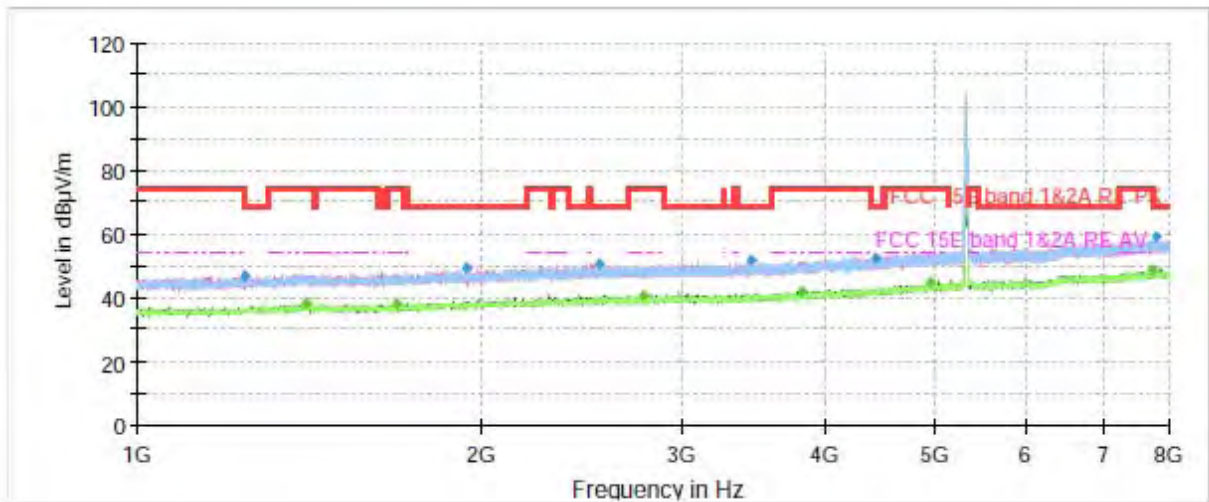

Note: The signal beyond the limit is carrier.
Radiates Emission from 1GHz to 8GHz

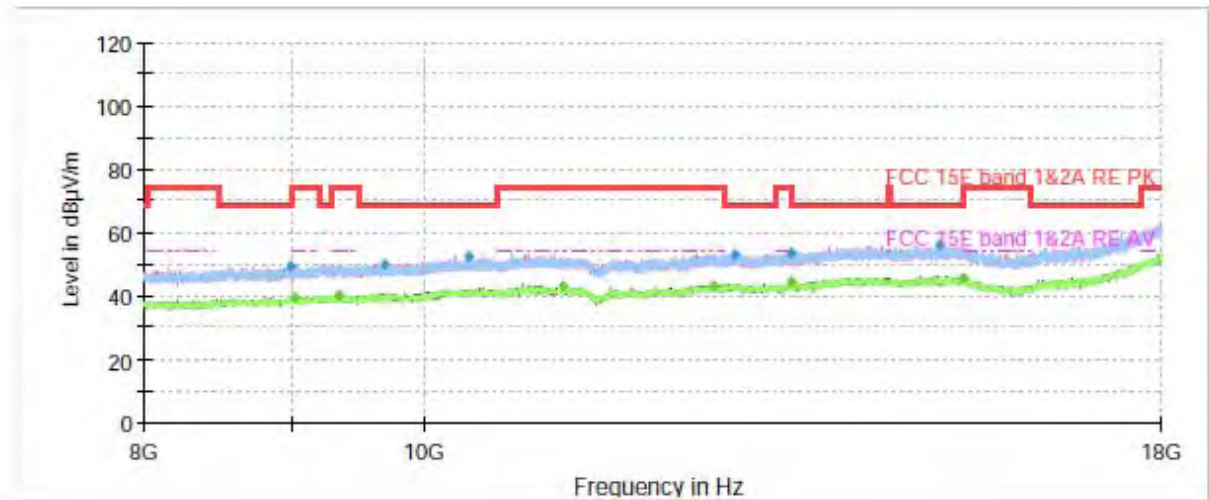

Radiates Emission from 8GHz to 18GHz



Frequency (MHz)	Peak (dBuV/m)	Average (dBuV/m)	Limit (dBuV/m)	Margin (dB)	Height (cm)	Polarization	Azimuth (deg)	Correct Factor (dB)
1244.533333	46.47	---	68.20	21.73	100.0	H	213.0	-8
1403.433333	---	37.99	54.00	16.01	200.0	H	148.0	-7
1689.266667	---	38.04	54.00	15.96	100.0	H	28.0	-6
1942.900000	48.93	---	68.20	19.27	100.0	H	4.0	-5
2540.466667	50.51	---	68.20	17.69	200.0	V	266.0	-4
2775.433333	---	40.54	54.00	13.46	200.0	V	359.0	-4
3453.733333	51.59	---	68.20	16.61	200.0	H	80.0	-3
3819.366667	---	42.02	54.00	11.98	100.0	V	285.0	-2
4426.733333	52.58	---	68.20	15.62	100.0	V	148.0	0
4939.133333	---	44.74	54.00	9.26	100.0	V	350.0	2
7743.800000	---	48.36	54.00	5.64	200.0	V	146.0	7
7787.900000	59.35	---	68.20	8.85	100.0	V	0.0	7

Remark: 1. Correction Factor = Antenna factor+ Insertion loss (cable loss + amplifier gain)

802.11a CH100

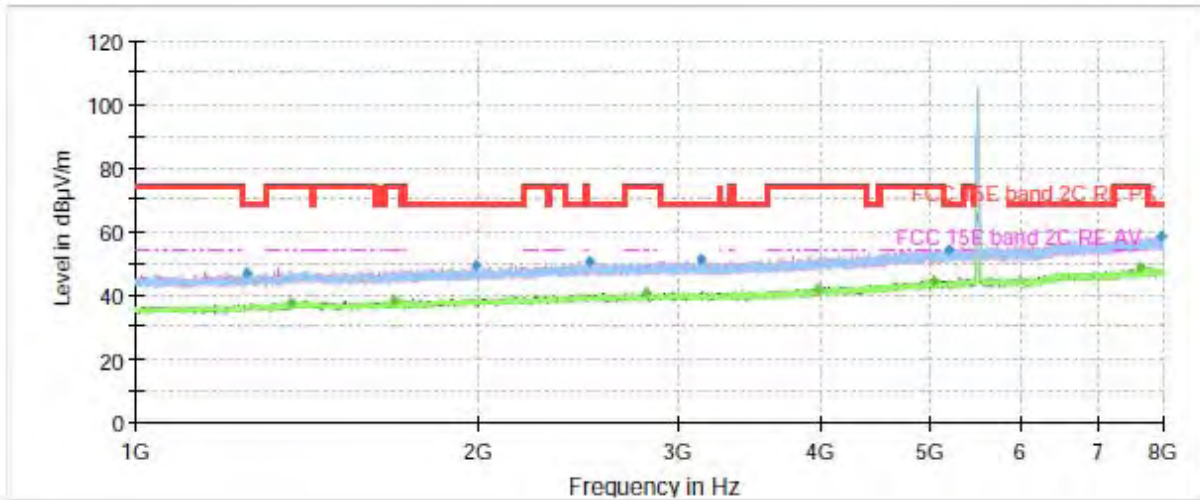

Note: The signal beyond the limit is carrier.
Radiates Emission from 1GHz to 8GHz

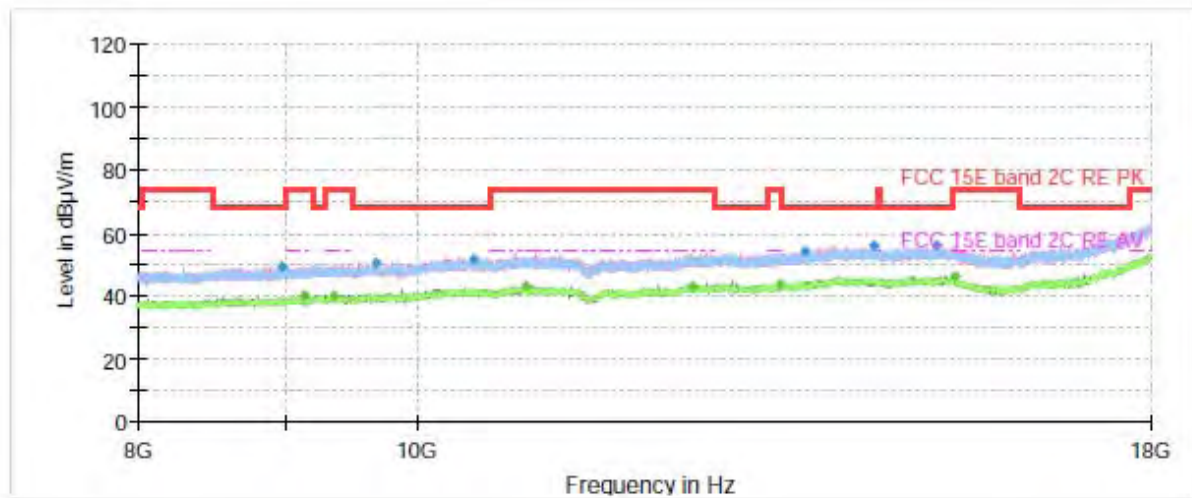

Radiates Emission from 8GHz to 18GHz



Frequency (MHz)	Peak (dBuV/m)	Average (dBuV/m)	Limit (dBuV/m)	Margin (dB)	Height (cm)	Polarization	Azimuth (deg)	Correct Factor (dB)
1254.800000	46.56	---	68.20	21.64	200.0	H	0.0	-8
1369.833333	---	37.82	54.00	16.18	200.0	H	270.0	-7
1688.800000	---	38.24	54.00	15.76	200.0	V	107.0	-6
1987.933333	49.49	---	68.20	18.71	100.0	V	162.0	-5
2501.033333	50.33	---	68.20	17.87	200.0	V	80.0	-4
2809.033333	---	40.55	54.00	13.45	100.0	V	162.0	-3
3138.500000	50.84	---	68.20	17.36	100.0	H	64.0	-3
3985.033333	---	42.09	54.00	11.91	100.0	V	254.0	-1
5022.200000	---	44.31	54.00	9.69	200.0	V	93.0	2
5186.933333	54.37	---	68.20	13.83	100.0	V	200.0	2
7646.500000	---	48.38	54.00	5.62	100.0	H	350.0	7
7953.333333	58.50	---	68.20	9.70	200.0	H	287.0	8

Remark: 1. Correction Factor = Antenna factor+ Insertion loss (cable loss + amplifier gain)

802.11a CH116

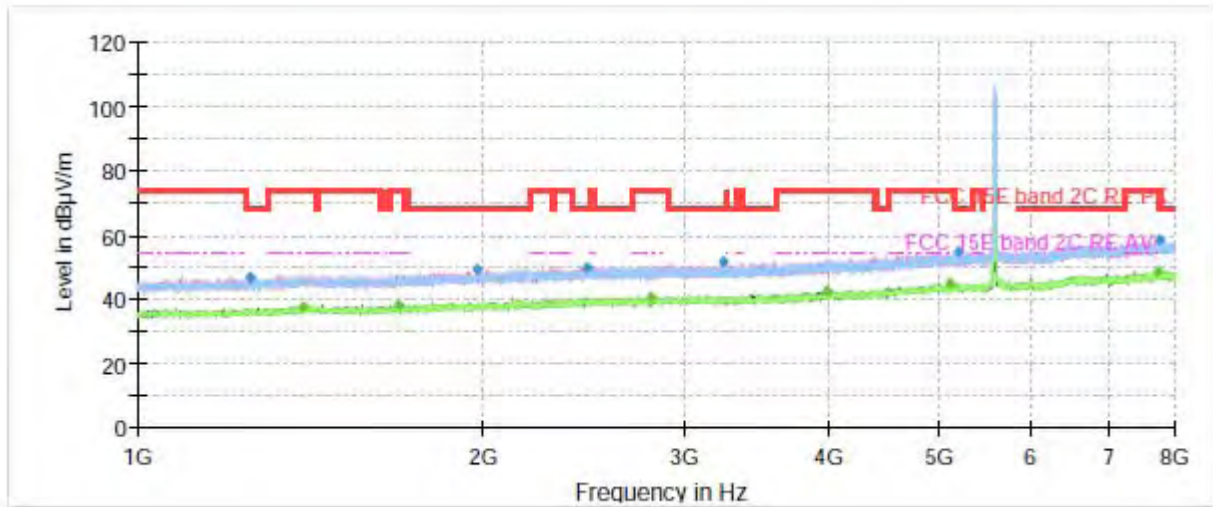

Note: The signal beyond the limit is carrier.
Radiates Emission from 1GHz to 8GHz

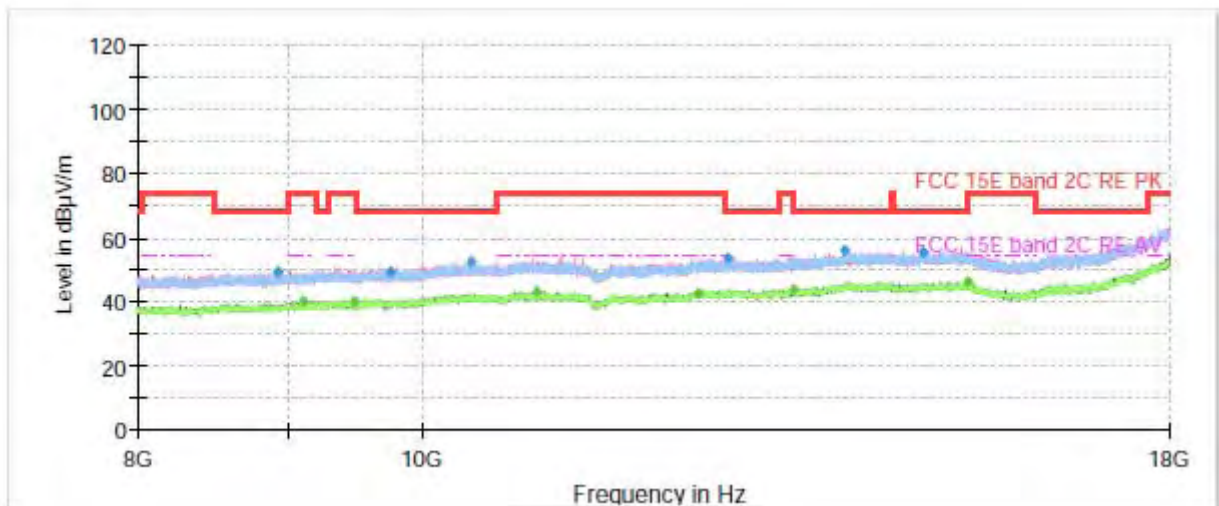

Radiates Emission from 8GHz to 18GHz



Frequency (MHz)	Peak (dBuV/m)	Average (dBuV/m)	Limit (dBuV/m)	Margin (dB)	Height (cm)	Polarization	Azimuth (deg)	Correct Factor (dB)
1250.366667	46.90	---	68.20	21.30	200.0	V	211.0	-8
1392.933333	---	37.67	54.00	16.33	200.0	H	297.0	-7
1688.800000	---	38.06	54.00	15.94	200.0	V	62.0	-6
1974.866667	49.48	---	68.20	18.72	200.0	H	335.0	-5
2461.833333	49.93	---	68.20	18.27	100.0	V	24.0	-4
2799.700000	---	40.84	54.00	13.16	100.0	V	0.0	-3
3236.033333	51.61	---	68.20	16.59	100.0	V	0.0	-3
3987.600000	---	42.39	54.00	11.61	200.0	H	212.0	-1
5105.966667	---	44.85	54.00	9.15	100.0	H	172.0	2
5173.633333	54.55	---	68.20	13.65	200.0	H	133.0	2
7744.266667	---	48.56	54.00	5.44	200.0	V	17.0	7
7778.800000	58.21	---	68.20	9.99	200.0	H	244.0	7

Remark: 1. Correction Factor = Antenna factor+ Insertion loss (cable loss + amplifier gain)

802.11a CH140

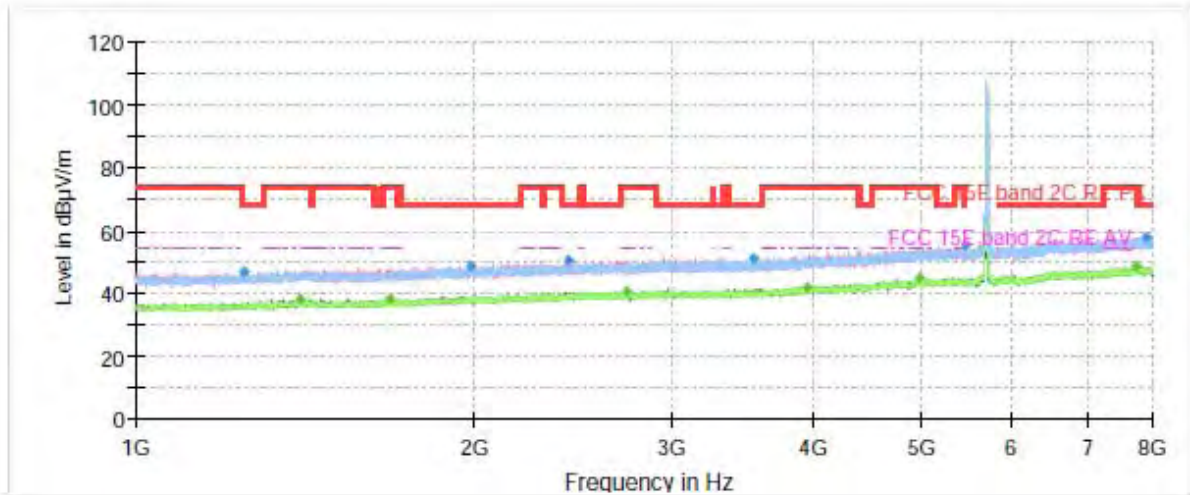

Note: The signal beyond the limit is carrier.
Radiates Emission from 1GHz to 8GHz

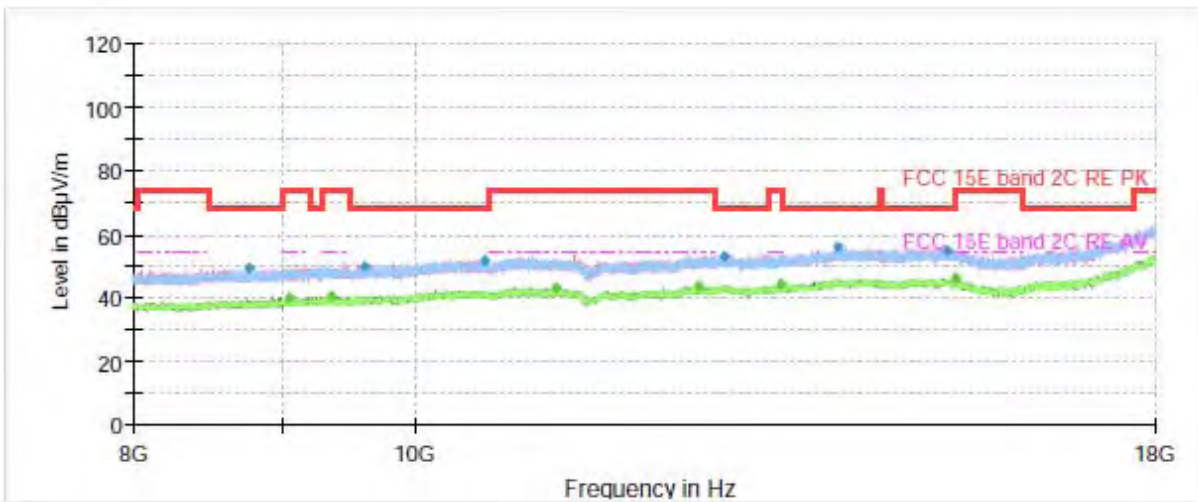

Radiates Emission from 8GHz to 18GHz



Frequency (MHz)	Peak (dBuV/m)	Average (dBuV/m)	Limit (dBuV/m)	Margin (dB)	Height (cm)	Polarization	Azimuth (deg)	Correct Factor (dB)
1245.933333	46.92	---	68.20	21.28	200.0	H	39.0	-8
1401.800000	---	38.07	54.00	15.93	200.0	V	102.0	-7
1677.133333	---	37.89	54.00	16.11	100.0	H	223.0	-6
1983.500000	48.78	---	68.20	19.42	200.0	V	16.0	-5
2417.500000	50.54	---	68.20	17.66	200.0	V	10.0	-4
2727.366667	---	40.60	54.00	13.40	100.0	H	10.0	-4
3537.966667	51.01	---	68.20	17.19	100.0	V	136.0	-3
3951.433333	---	42.09	54.00	11.91	100.0	V	67.0	-1
4978.566667	---	45.08	54.00	8.92	200.0	H	108.0	2
5465.766667	55.28	---	68.20	12.92	200.0	V	196.0	3
7743.566667	---	48.50	54.00	5.50	100.0	V	230.0	7
7899.666667	58.14	---	68.20	10.06	200.0	H	190.0	7

Remark: 1. Correction Factor = Antenna factor+ Insertion loss (cable loss + amplifier gain)

802.11a CH144

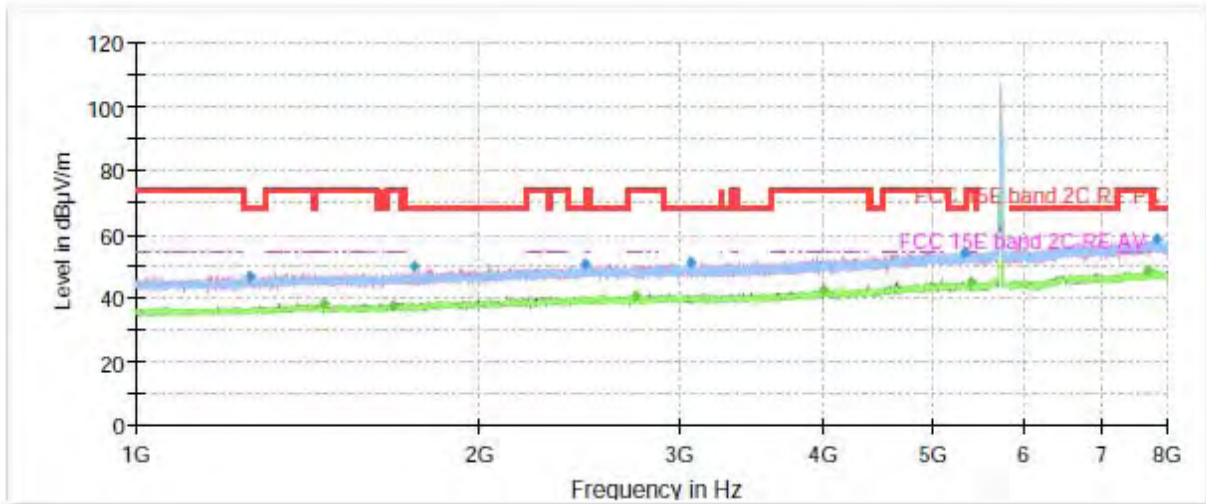

Note: The signal beyond the limit is carrier.
Radiates Emission from 1GHz to 8GHz

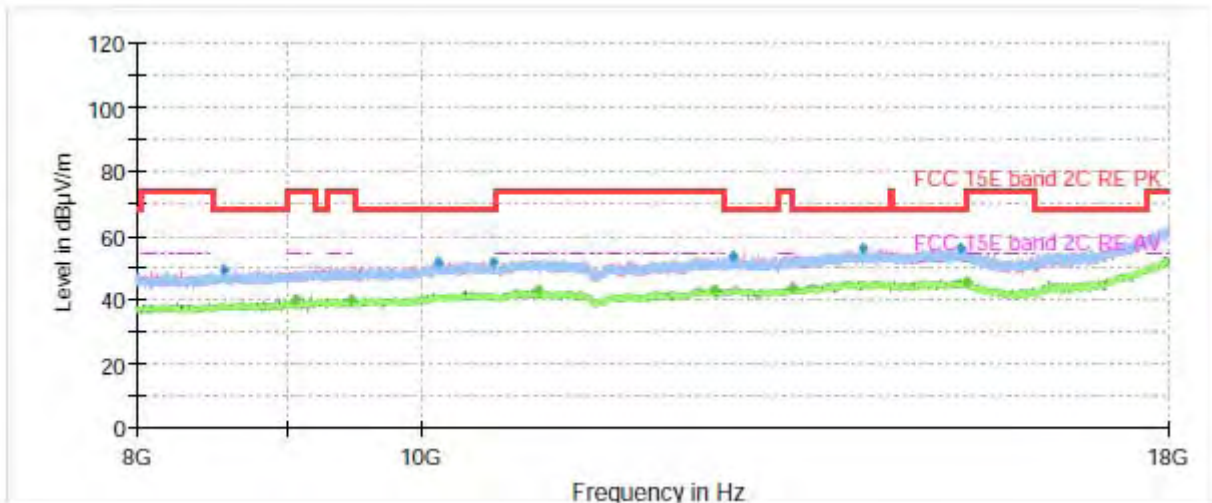

Radiates Emission from 8GHz to 18GHz



Frequency (MHz)	Peak (dBuV/m)	Average (dBuV/m)	Limit (dBuV/m)	Margin (dB)	Height (cm)	Polarization	Azimuth (deg)	Correct Factor (dB)
1259.466667	46.73	---	68.20	21.47	100.0	H	79.0	-8
1459.200000	---	38.15	54.00	15.85	200.0	V	210.0	-7
1681.100000	---	37.42	54.00	16.58	200.0	V	294.0	-6
1755.300000	49.62	---	68.20	18.58	100.0	H	10.0	-6
2474.433333	50.55	---	68.20	17.65	100.0	V	166.0	-4
2743.233333	---	40.68	54.00	13.32	200.0	V	196.0	-4
3065.700000	51.24	---	68.20	16.96	200.0	H	68.0	-3
3999.500000	---	42.31	54.00	11.69	100.0	V	359.0	-1
5308.033333	54.33	---	68.20	13.87	100.0	V	344.0	2
5378.733333	---	45.21	54.00	8.79	200.0	V	19.0	3
7707.633333	---	48.65	54.00	5.35	200.0	V	336.0	7
7817.066667	58.40	---	68.20	9.80	200.0	V	12.0	7

Remark: 1. Correction Factor = Antenna factor+ Insertion loss (cable loss + amplifier gain)

802.11a CH149

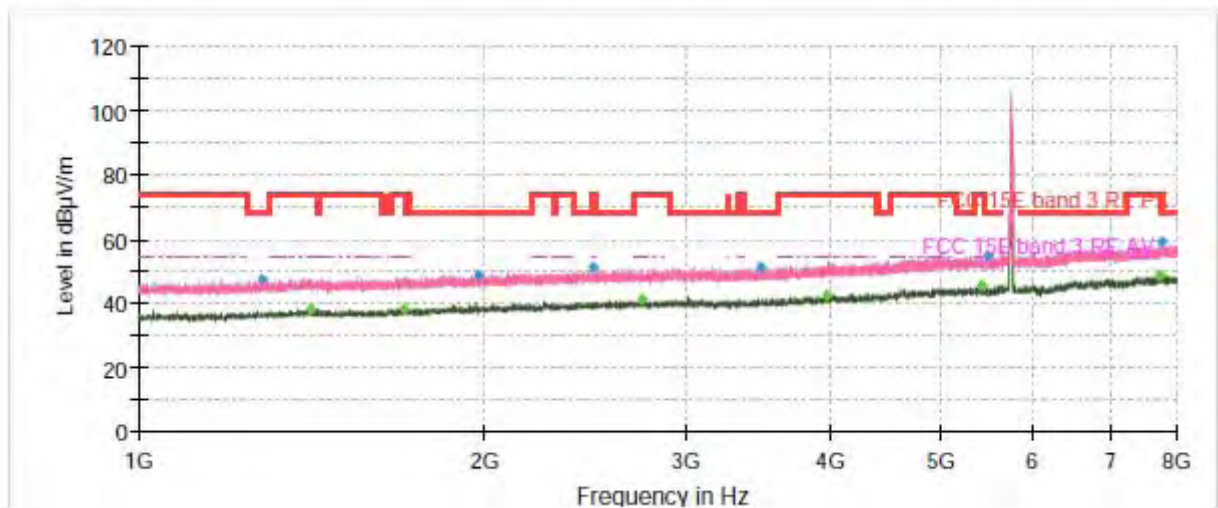

Note: The signal beyond the limit is carrier.
Radiates Emission from 1GHz to 8GHz

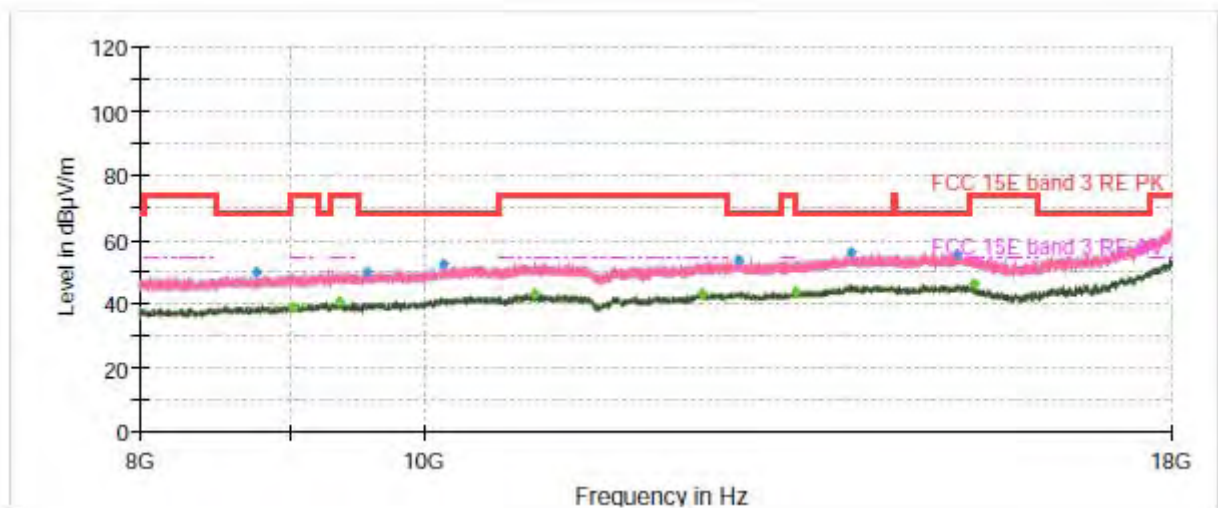

Radiates Emission from 8GHz to 18GHz



Frequency (MHz)	Peak (dBuV/m)	Average (dBuV/m)	Limit (dBuV/m)	Margin (dB)	Height (cm)	Polarization	Azimuth (deg)	Correct Factor (dB)
1280.233333	47.37	---	68.20	20.83	100.0	H	201.0	-8
1410.200000	---	37.99	54.00	16.01	200.0	H	294.0	-7
1698.133333	---	38.16	54.00	15.84	200.0	V	94.0	-6
1978.133333	48.73	---	68.20	19.47	200.0	V	295.0	-5
2483.066667	51.15	---	68.20	17.05	200.0	H	194.0	-4
2741.600000	---	41.07	54.00	12.93	200.0	V	356.0	-4
3469.833333	51.25	---	68.20	16.95	100.0	H	52.0	-3
3967.533333	---	42.61	54.00	11.39	200.0	H	141.0	-1
5399.266667	---	45.29	54.00	8.71	200.0	H	34.0	3
5486.300000	55.07	---	68.20	13.13	200.0	H	4.0	3
7747.533333	---	48.66	54.00	5.34	200.0	V	358.0	7
7755.700000	58.83	---	68.20	9.37	100.0	H	269.0	7

Remark: 1. Correction Factor = Antenna factor+ Insertion loss (cable loss + amplifier gain)

802.11a CH157

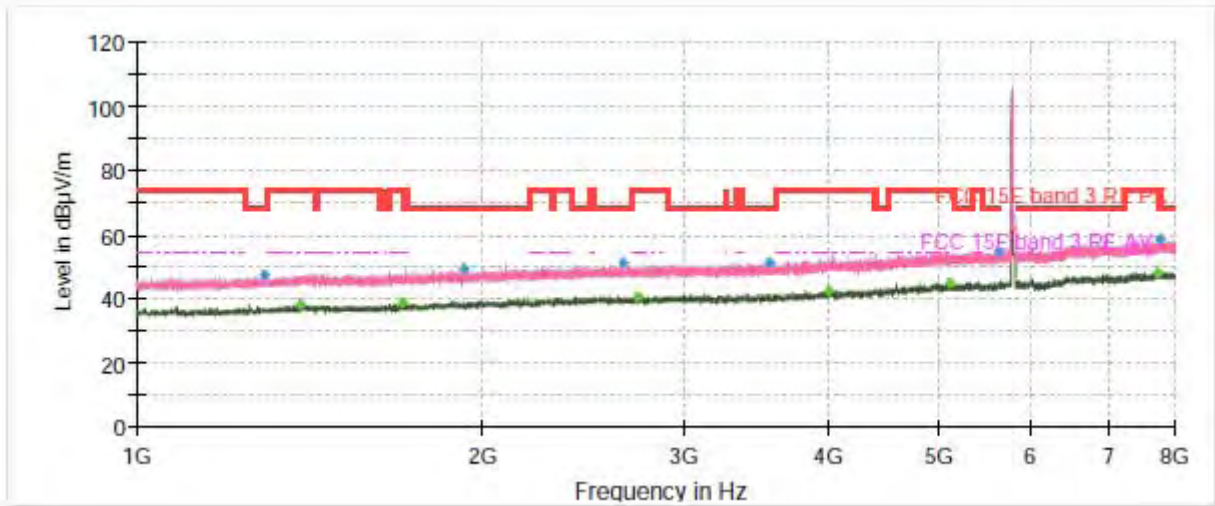

Note: The signal beyond the limit is carrier.
Radiates Emission from 1GHz to 8GHz

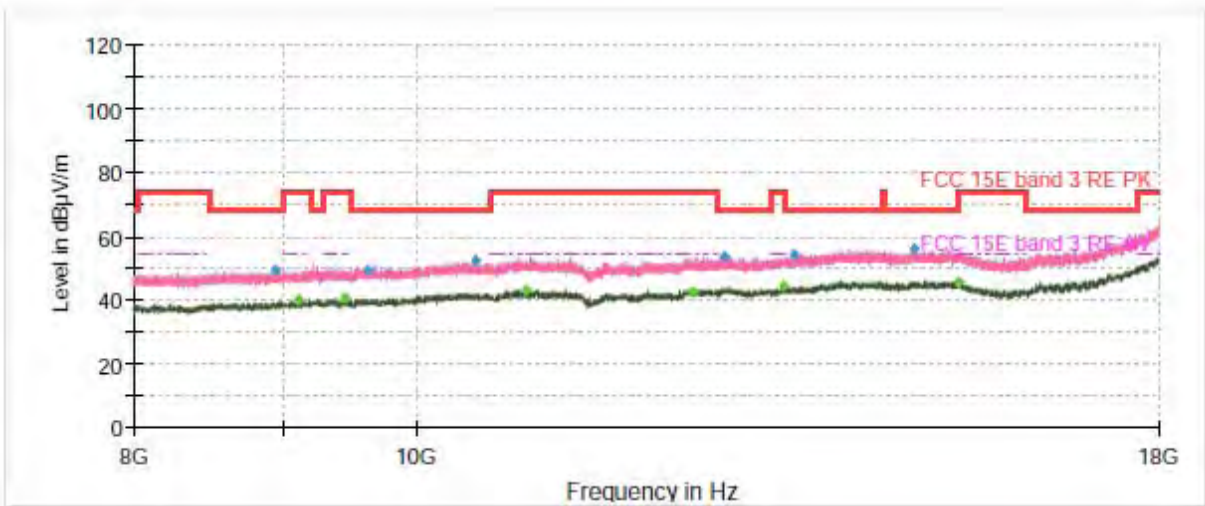

Radiates Emission from 8GHz to 18GHz



Frequency (MHz)	Peak (dBuV/m)	Average (dBuV/m)	Limit (dBuV/m)	Margin (dB)	Height (cm)	Polarization	Azimuth (deg)	Correct Factor (dB)
1291.666667	47.59	---	68.20	20.61	200.0	H	131.0	-8
1386.166667	---	38.28	54.00	15.72	100.0	H	193.0	-7
1704.433333	---	38.55	54.00	15.45	100.0	V	3.0	-6
1924.233333	49.33	---	68.20	18.87	200.0	H	336.0	-5
2648.266667	50.97	---	68.20	17.23	200.0	V	332.0	-4
2727.366667	---	40.74	54.00	13.26	200.0	V	242.0	-4
3554.533333	50.97	---	68.20	17.23	200.0	H	6.0	-3
3998.333333	---	42.54	54.00	11.46	200.0	V	320.0	-1
5099.200000	---	44.96	54.00	9.04	200.0	V	215.0	2
5625.366667	54.87	---	68.20	13.33	200.0	H	17.0	3
7721.866667	---	48.19	54.00	5.81	100.0	H	286.0	7
7754.066667	58.27	---	68.20	9.93	100.0	H	259.0	7

Remark: 1. Correction Factor = Antenna factor+ Insertion loss (cable loss + amplifier gain)

802.11a CH165

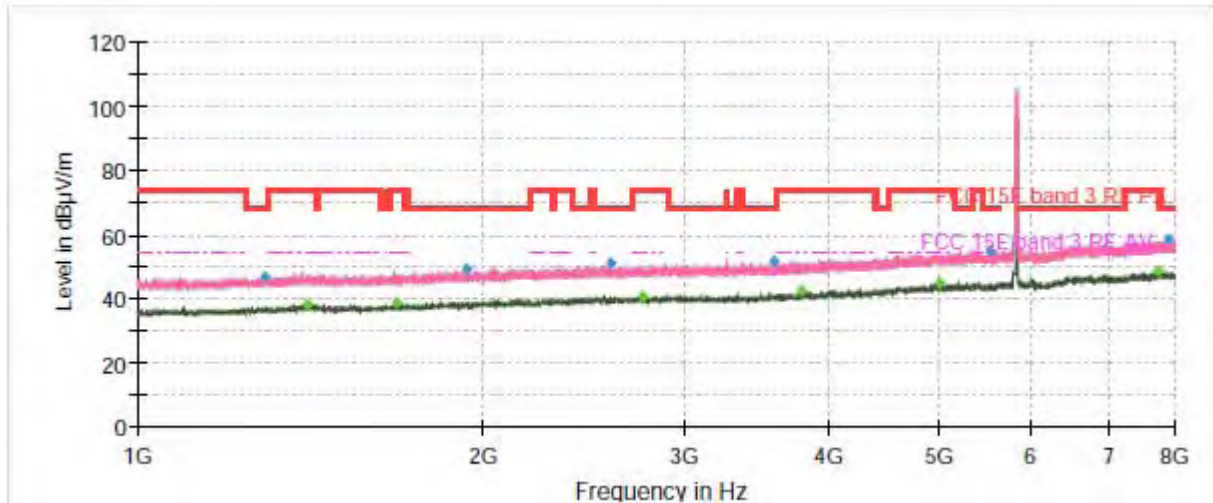

Note: The signal beyond the limit is carrier.
Radiates Emission from 1GHz to 8GHz

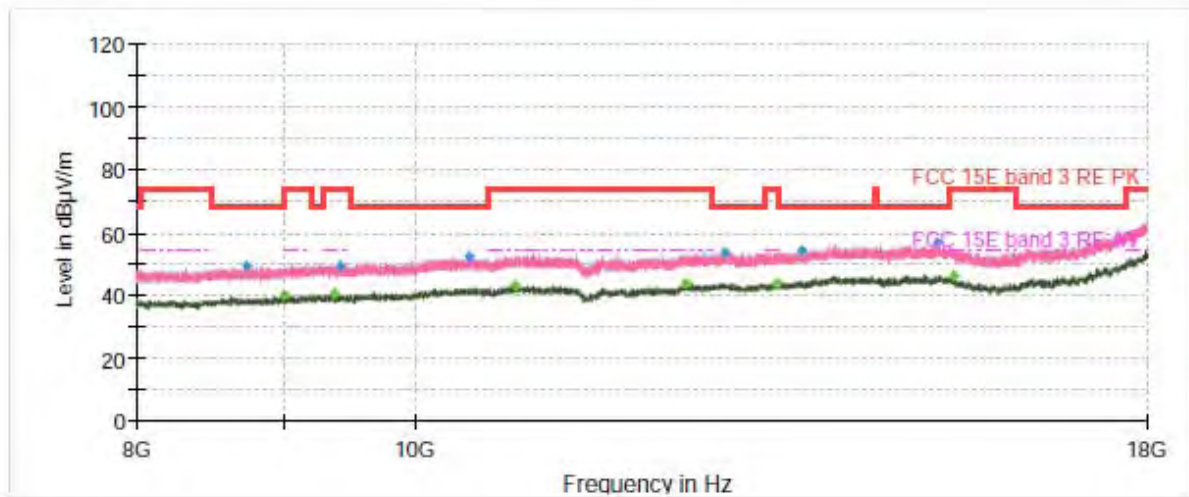

Radiates Emission from 8GHz to 18GHz



Frequency (MHz)	Peak (dBuV/m)	Average (dBuV/m)	Limit (dBuV/m)	Margin (dB)	Height (cm)	Polarization	Azimuth (deg)	Correct Factor (dB)
1289.566667	46.81	---	68.20	21.39	200.0	H	157.0	-8
1402.733333	---	38.00	54.00	16.00	200.0	H	35.0	-7
1677.833333	---	38.68	54.00	15.32	100.0	V	358.0	-6
1931.233333	48.93	---	68.20	19.27	100.0	V	14.0	-5
2579.900000	50.94	---	68.20	17.26	100.0	V	14.0	-4
2752.800000	---	40.86	54.00	13.14	200.0	H	118.0	-4
3580.666667	51.53	---	68.20	16.67	200.0	V	327.0	-3
3789.266667	---	42.32	54.00	11.68	200.0	H	15.0	-2
4985.333333	---	44.81	54.00	9.19	100.0	V	238.0	2
5519.666667	54.89	---	68.20	13.31	200.0	V	359.0	3
7744.266667	---	48.34	54.00	5.66	200.0	V	113.0	7
7903.866667	58.57	---	68.20	9.63	100.0	V	8.0	7

Remark: 1. Correction Factor = Antenna factor+ Insertion loss (cable loss + amplifier gain)

802.11n (HT20) CH36

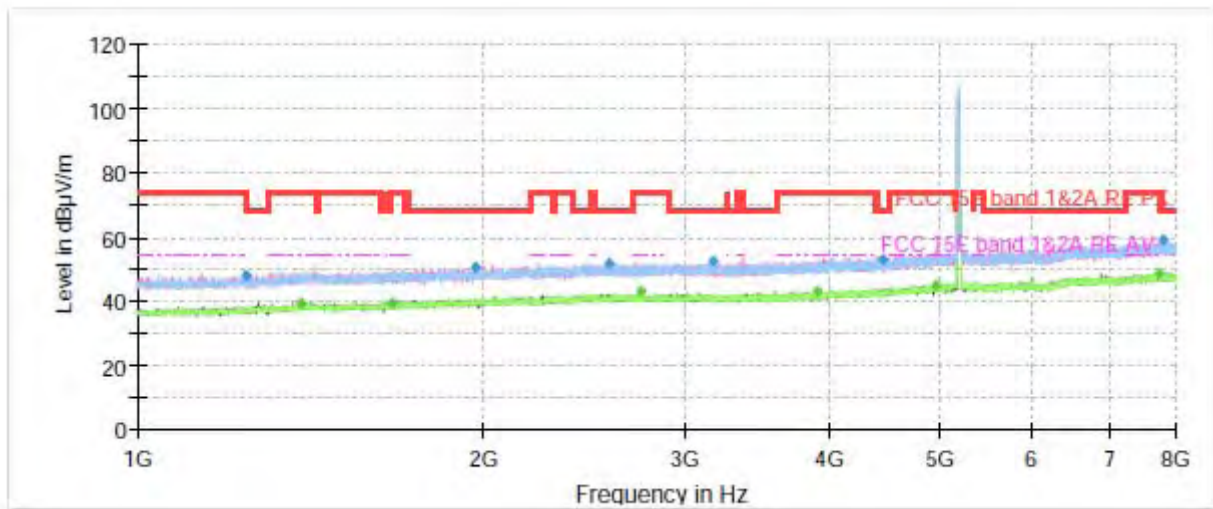

Note: The signal beyond the limit is carrier.
Radiates Emission from 1GHz to 8GHz

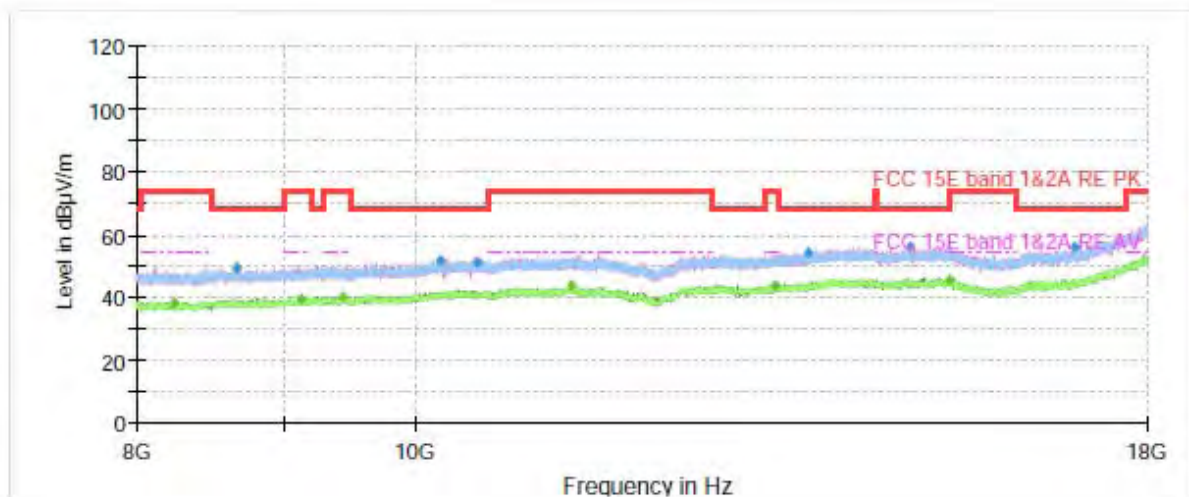

Radiates Emission from 8GHz to 18GHz



Frequency (MHz)	Peak (dBuV/m)	Average (dBuV/m)	Limit (dBuV/m)	Margin (dB)	Height (cm)	Polarization	Azimuth (deg)	Correct Factor (dB)
1243.833333	48.13	---	68.20	20.07	200.0	H	50.0	-8
1388.500000	---	39.29	54.00	14.71	100.0	V	359.0	-7
1662.900000	---	39.56	54.00	14.44	100.0	H	0.0	-6
1966.933333	50.55	---	68.20	17.65	200.0	V	175.0	-5
2574.066667	51.94	---	68.20	16.26	200.0	H	76.0	-4
2740.666667	---	42.82	54.00	11.18	200.0	H	251.0	-4
3167.900000	52.56	---	68.20	15.64	200.0	V	175.0	-3
3904.533333	---	42.94	54.00	11.06	200.0	H	90.0	-2
4455.433333	53.20	---	68.20	15.00	200.0	H	63.0	0
4948.700000	---	45.10	54.00	8.90	100.0	V	191.0	2
7738.666667	---	48.90	54.00	5.10	200.0	H	24.0	7
7785.333333	58.97	---	68.20	9.23	200.0	V	93.0	7

Remark: 1. Correction Factor = Antenna factor+ Insertion loss (cable loss + amplifier gain)

802.11n (HT20) CH40

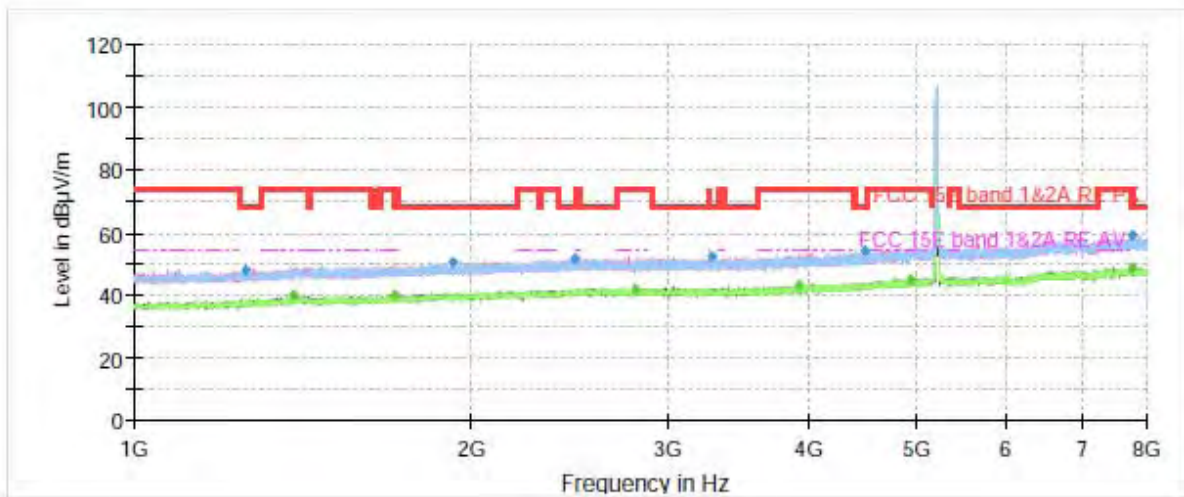

Note: The signal beyond the limit is carrier.
Radiates Emission from 1GHz to 8GHz

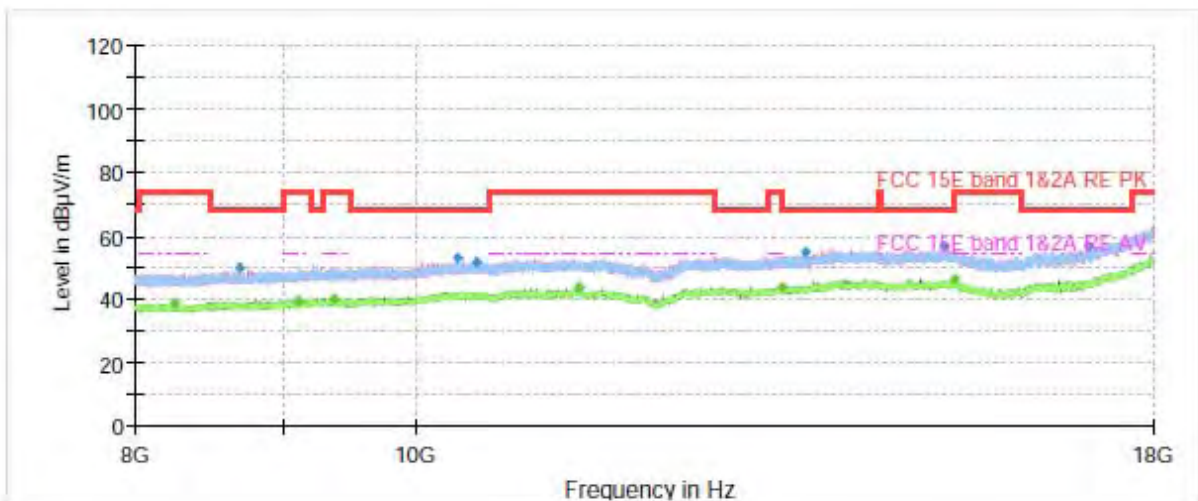

Radiates Emission from 8GHz to 18GHz



Frequency (MHz)	Peak (dBuV/m)	Average (dBuV/m)	Limit (dBuV/m)	Margin (dB)	Height (cm)	Polarization	Azimuth (deg)	Correct Factor (dB)
1255.500000	48.02	---	68.20	20.18	100.0	V	100.0	-8
1388.733333	---	40.08	54.00	13.92	200.0	V	334.0	-7
1706.533333	---	39.99	54.00	14.01	200.0	V	283.0	-6
1921.200000	50.55	---	68.20	17.65	200.0	H	3.0	-5
2472.800000	51.86	---	68.20	16.34	200.0	H	9.0	-4
2800.166667	---	42.07	54.00	11.93	100.0	V	0.0	-3
3278.033333	52.08	---	68.20	16.12	100.0	H	37.0	-3
3909.200000	---	43.15	54.00	10.85	200.0	H	279.0	-2
4480.166667	54.42	---	68.20	13.78	200.0	H	60.0	0
4929.333333	---	44.97	54.00	9.03	200.0	V	190.0	2
7749.166667	---	48.68	54.00	5.32	100.0	V	260.0	7
7763.866667	59.31	---	68.20	8.89	100.0	V	9.0	7

Remark: 1. Correction Factor = Antenna factor+ Insertion loss (cable loss + amplifier gain)

802.11n (HT20) CH48

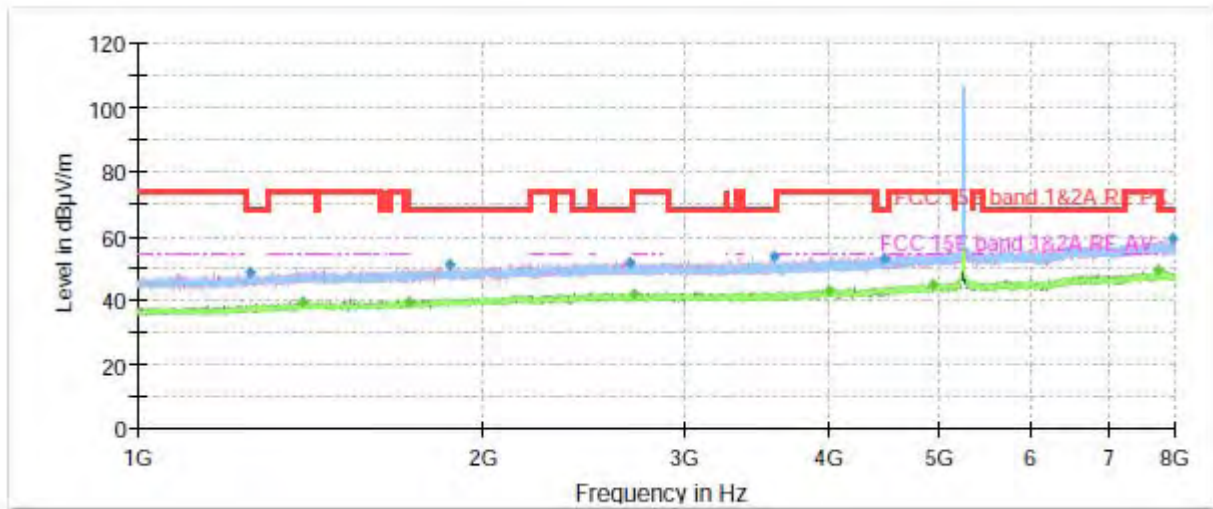

Note: The signal beyond the limit is carrier.
Radiates Emission from 1GHz to 8GHz

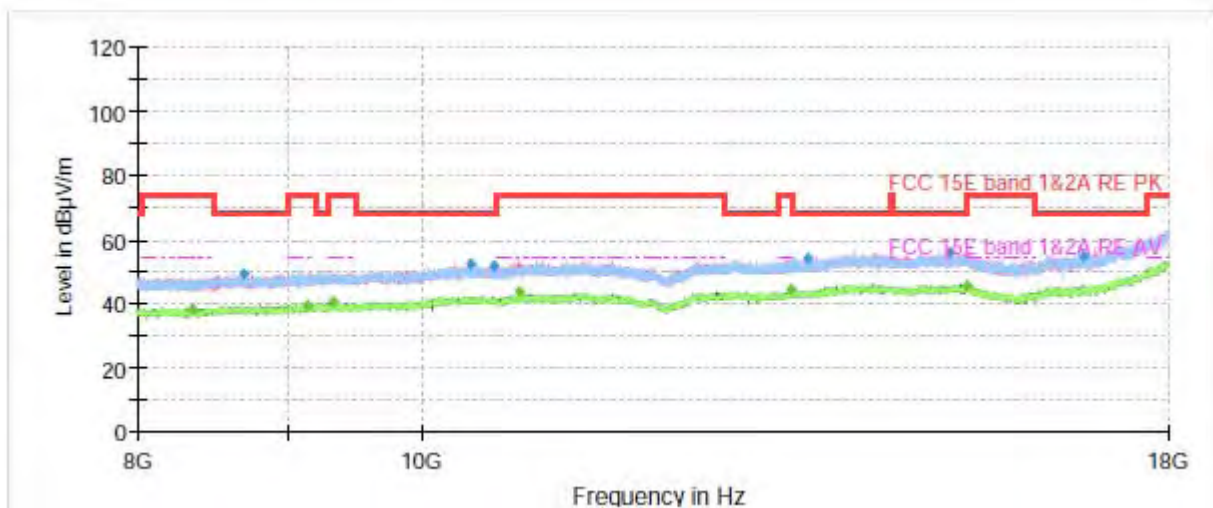

Radiates Emission from 8GHz to 18GHz



Frequency (MHz)	Peak (dBuV/m)	Average (dBuV/m)	Limit (dBuV/m)	Margin (dB)	Height (cm)	Polarization	Azimuth (deg)	Correct Factor (dB)
1250.366667	48.33	---	68.20	19.87	100.0	H	303.0	-8
1394.100000	---	39.28	54.00	14.72	100.0	H	342.0	-7
1721.933333	---	39.50	54.00	14.50	200.0	V	334.0	-6
1871.500000	50.95	---	68.20	17.25	200.0	V	343.0	-5
2680.700000	51.56	---	68.20	16.64	100.0	H	236.0	-3
2707.066667	---	42.03	54.00	11.97	200.0	H	0.0	-4
3587.200000	53.39	---	68.20	14.81	200.0	H	0.0	-3
3997.400000	---	43.23	54.00	10.77	200.0	V	110.0	-1
4464.766667	53.21	---	68.20	14.99	200.0	H	168.0	0
4935.866667	---	45.07	54.00	8.93	100.0	V	58.0	2
7747.300000	---	49.36	54.00	4.64	200.0	V	359.0	7
7956.600000	58.83	---	68.20	9.37	100.0	V	5.0	8

Remark: 1. Correction Factor = Antenna factor+ Insertion loss (cable loss + amplifier gain)



802.11n (HT20) CH52

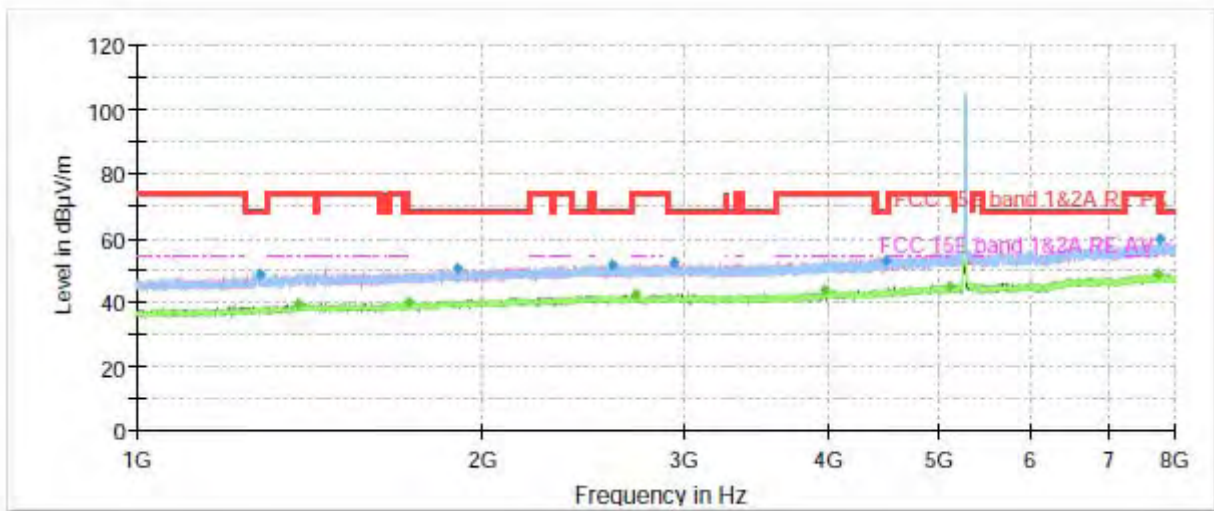

Note: The signal beyond the limit is carrier.
Radiates Emission from 1GHz to 8GHz

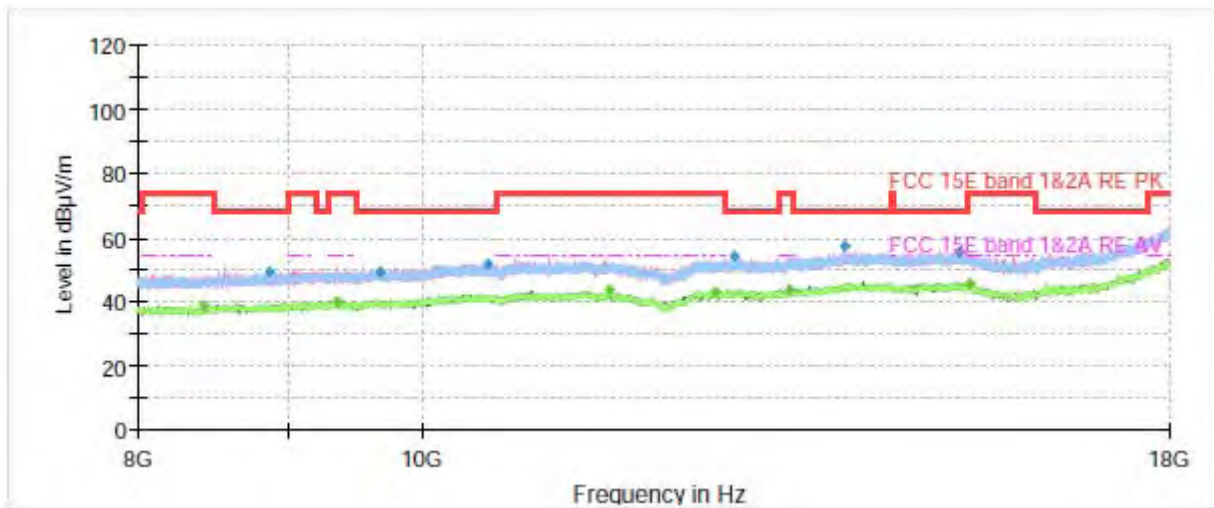

Radiates Emission from 8GHz to 18GHz



Frequency (MHz)	Peak (dBuV/m)	Average (dBuV/m)	Limit (dBuV/m)	Margin (dB)	Height (cm)	Polarization	Azimuth (deg)	Correct Factor (dB)
1277.433333	48.67	---	68.20	19.53	200.0	V	188.0	-8
1381.500000	---	39.67	54.00	14.33	200.0	V	215.0	-7
1720.766667	---	40.15	54.00	13.85	100.0	H	342.0	-6
1897.400000	50.21	---	68.20	17.99	100.0	H	359.0	-5
2593.666667	51.75	---	68.20	16.45	100.0	V	15.0	-4
2716.166667	---	42.17	54.00	11.83	100.0	V	279.0	-4
2931.066667	52.55	---	68.20	15.65	200.0	H	292.0	-3
3961.466667	---	43.39	54.00	10.61	200.0	V	354.0	-1
4479.000000	53.18	---	68.20	15.02	100.0	H	282.0	0
5106.900000	---	44.95	54.00	9.05	200.0	V	10.0	2
7745.900000	---	48.88	54.00	5.12	100.0	H	108.0	7
7758.733333	59.61	---	68.20	8.59	200.0	V	281.0	7

Remark: 1. Correction Factor = Antenna factor+ Insertion loss (cable loss + amplifier gain)



802.11n (HT20) CH60

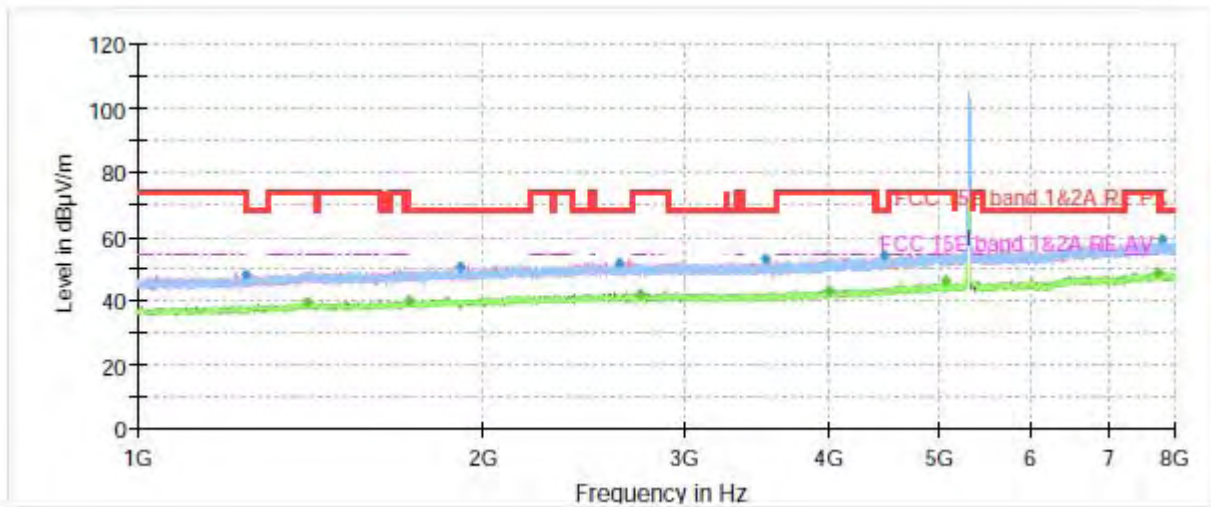

Note: The signal beyond the limit is carrier.
Radiates Emission from 1GHz to 8GHz

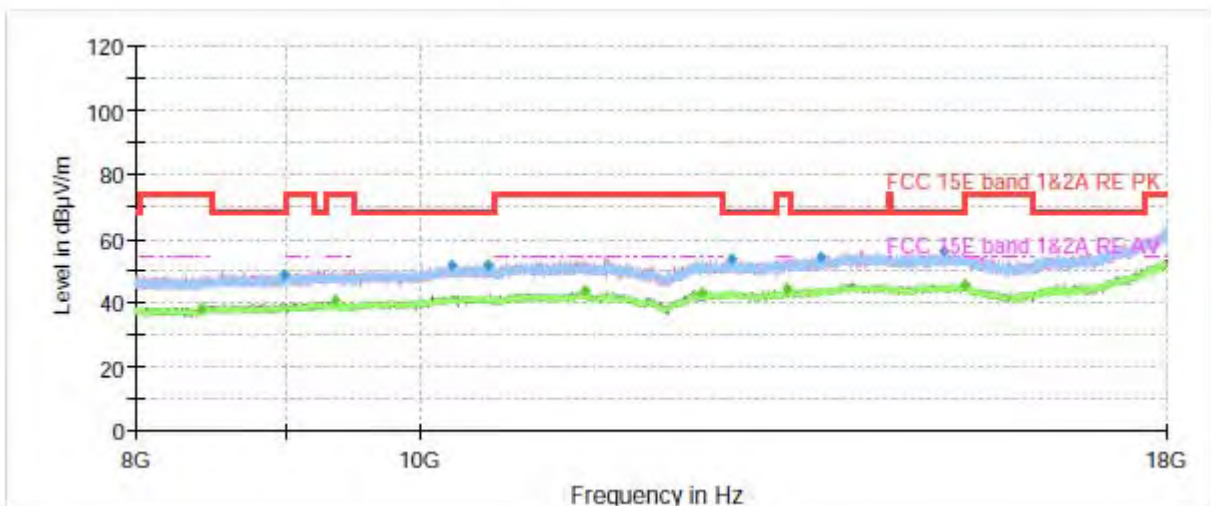

Radiates Emission from 8GHz to 18GHz



Frequency (MHz)	Peak (dBuV/m)	Average (dBuV/m)	Limit (dBuV/m)	Margin (dB)	Height (cm)	Polarization	Azimuth (deg)	Correct Factor (dB)
1240.100000	48.13	---	68.20	20.07	100.0	V	36.0	-8
1404.600000	---	39.41	54.00	14.59	100.0	V	10.0	-7
1721.000000	---	39.78	54.00	14.22	100.0	V	25.0	-6
1907.900000	50.34	---	68.20	17.86	200.0	H	197.0	-5
2621.433333	51.79	---	68.20	16.41	100.0	H	261.0	-4
2736.000000	---	42.07	54.00	11.93	200.0	V	0.0	-4
3521.866667	53.15	---	68.20	15.05	200.0	V	181.0	-3
3999.733333	---	42.95	54.00	11.05	100.0	H	0.0	-1
4471.066667	54.15	---	68.20	14.05	100.0	H	247.0	0
5056.966667	---	45.98	54.00	8.02	200.0	V	54.0	2
7742.633333	---	48.71	54.00	5.29	100.0	H	193.0	7
7796.766667	58.93	---	68.20	9.27	200.0	V	300.0	7

Remark: 1. Correction Factor = Antenna factor+ Insertion loss (cable loss + amplifier gain)



802.11n (HT20) CH64

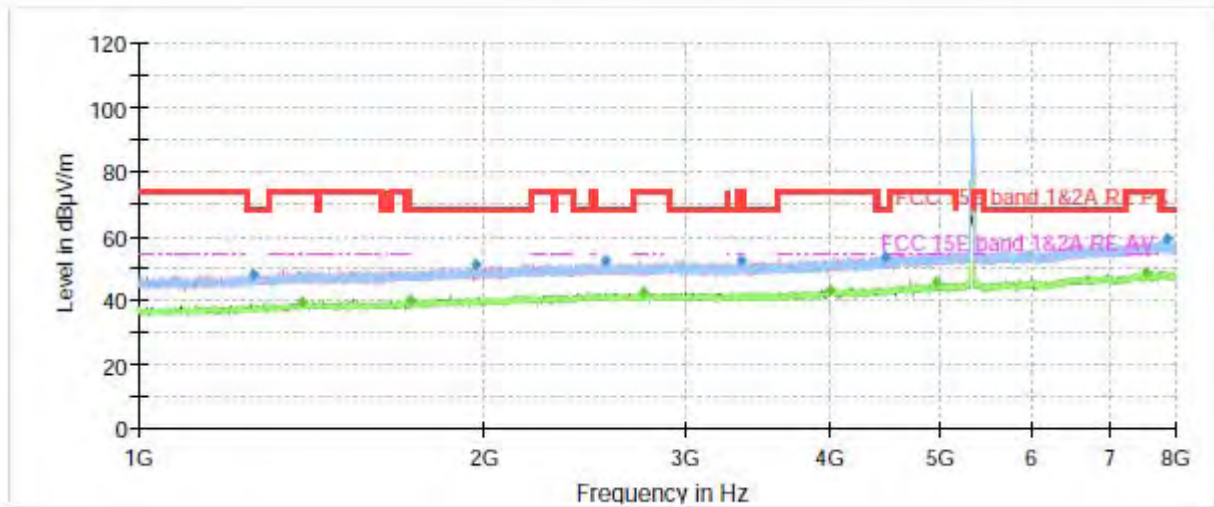

Note: The signal beyond the limit is carrier.
Radiates Emission from 1GHz to 8GHz

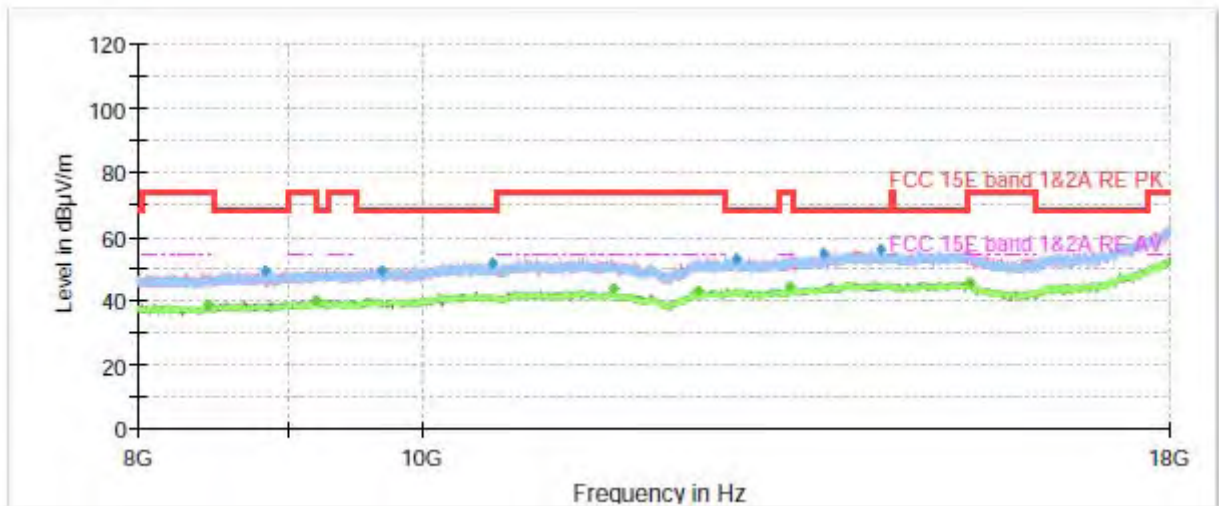

Radiates Emission from 8GHz to 18GHz



Frequency (MHz)	Peak (dBuV/m)	Average (dBuV/m)	Limit (dBuV/m)	Margin (dB)	Height (cm)	Polarization	Azimuth (deg)	Correct Factor (dB)
1258.533333	48.27	---	68.20	19.93	100.0	V	61.0	-8
1387.100000	---	39.55	54.00	14.45	200.0	H	10.0	-7
1721.466667	---	39.87	54.00	14.13	200.0	H	336.0	-6
1966.000000	51.06	---	68.20	17.14	100.0	H	66.0	-5
2548.166667	52.54	---	68.20	15.66	100.0	H	359.0	-4
2753.266667	---	42.60	54.00	11.40	200.0	V	357.0	-4
3342.200000	52.23	---	68.20	15.97	200.0	V	68.0	-3
3999.733333	---	43.26	54.00	10.74	100.0	H	203.0	-1
4463.133333	53.41	---	68.20	14.79	100.0	H	0.0	0
4955.233333	---	45.31	54.00	8.69	200.0	V	270.0	2
7524.466667	---	48.69	54.00	5.31	100.0	H	346.0	7
7852.066667	58.80	---	68.20	9.40	200.0	H	4.0	7

Remark: 1. Correction Factor = Antenna factor+ Insertion loss (cable loss + amplifier gain)

802.11n (HT20) CH100

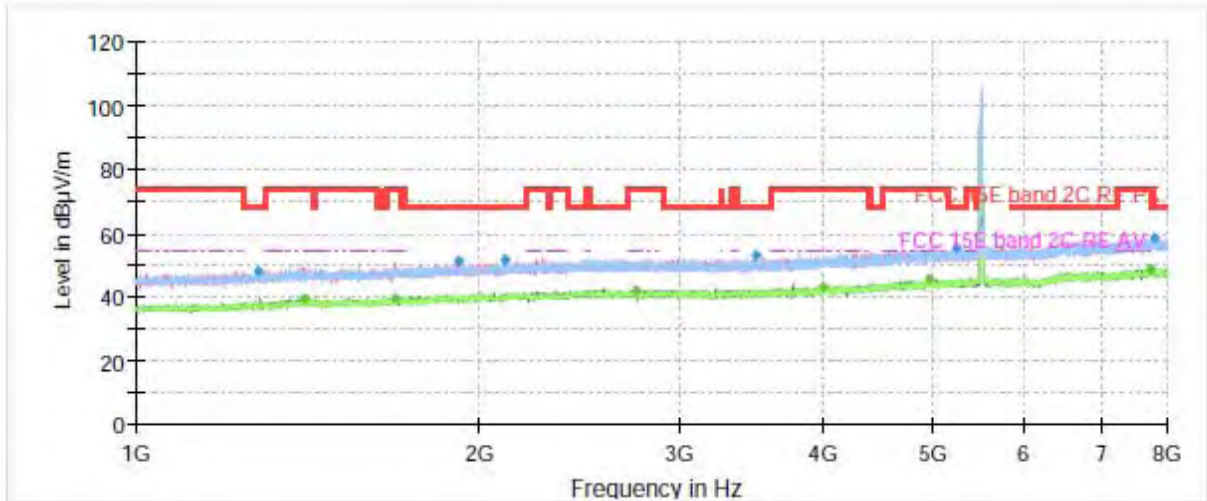

Note: The signal beyond the limit is carrier.
Radiates Emission from 1GHz to 8GHz

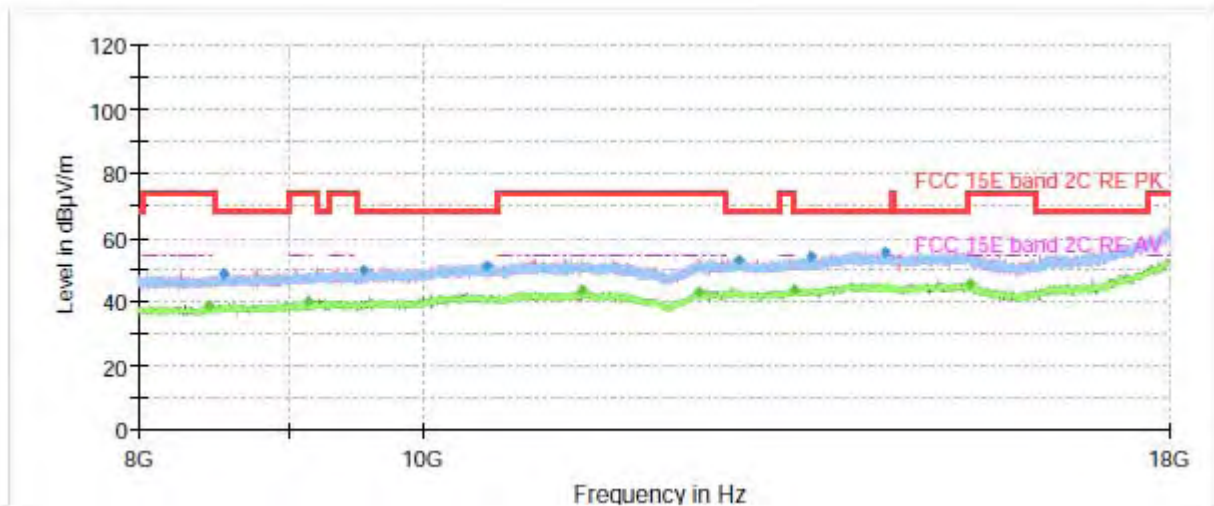

Radiates Emission from 8GHz to 18GHz



Frequency (MHz)	Peak (dBuV/m)	Average (dBuV/m)	Limit (dBuV/m)	Margin (dB)	Height (cm)	Polarization	Azimuth (deg)	Correct Factor (dB)
1279.300000	48.05	---	68.20	20.15	200.0	H	357.0	-8
1403.433333	---	39.17	54.00	14.83	100.0	V	358.0	-7
1690.666667	---	39.68	54.00	14.32	200.0	V	11.0	-6
1919.800000	50.81	---	68.20	17.39	100.0	H	305.0	-5
2104.833333	51.62	---	68.20	16.58	200.0	H	71.0	-4
2737.166667	---	42.14	54.00	11.86	200.0	V	95.0	-4
3495.033333	52.62	---	68.20	15.58	200.0	V	0.0	-3
3998.800000	---	43.34	54.00	10.66	100.0	H	51.0	-1
4948.466667	---	45.69	54.00	8.31	200.0	H	152.0	2
5223.333333	55.31	---	68.20	12.89	200.0	H	314.0	2
7744.733333	---	48.61	54.00	5.39	200.0	H	355.0	7
7796.066667	58.76	---	68.20	9.44	100.0	V	266.0	7

Remark: 1. Correction Factor = Antenna factor+ Insertion loss (cable loss + amplifier gain)

802.11n (HT20) CH116

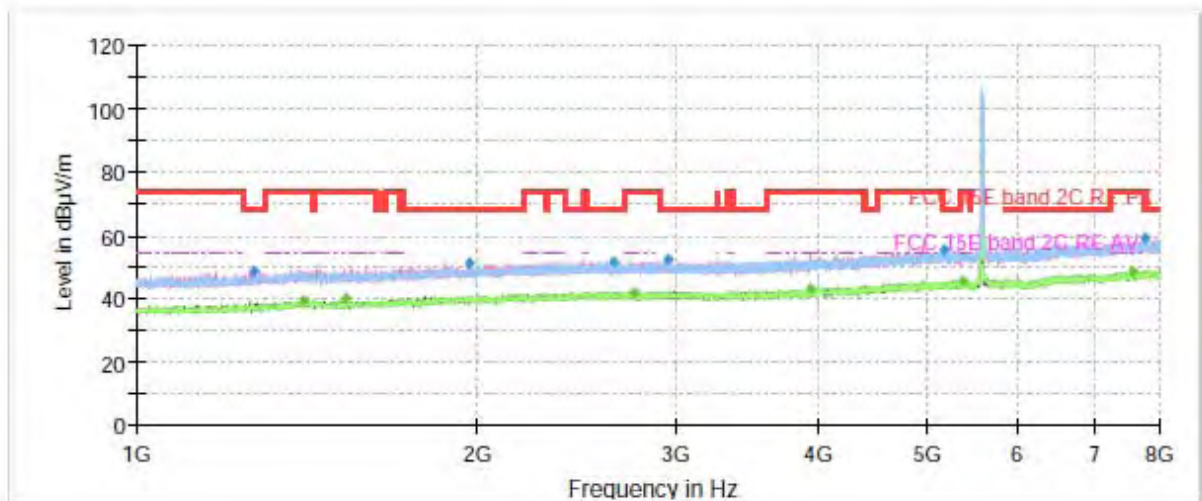

Note: The signal beyond the limit is carrier.
Radiates Emission from 1GHz to 8GHz

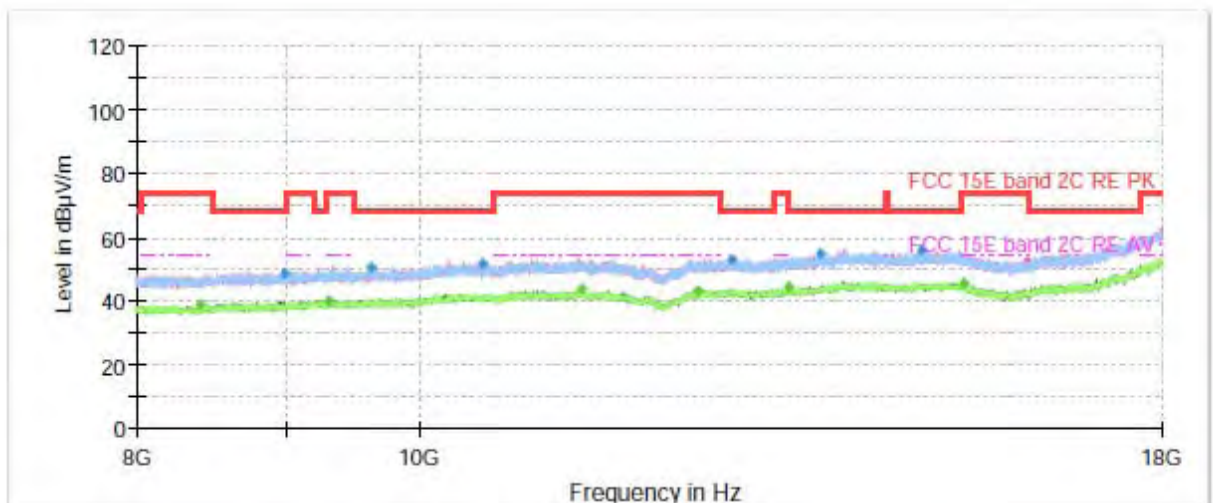

Radiates Emission from 8GHz to 18GHz



Frequency (MHz)	Peak (dBuV/m)	Average (dBuV/m)	Limit (dBuV/m)	Margin (dB)	Height (cm)	Polarization	Azimuth (deg)	Correct Factor (dB)
1267.633333	48.59	---	68.20	19.61	100.0	V	339.0	-8
1403.200000	---	39.30	54.00	14.70	200.0	V	0.0	-7
1528.733333	---	39.74	54.00	14.26	200.0	V	2.0	-7
1969.966667	51.11	---	68.20	17.09	100.0	H	169.0	-5
2631.933333	51.94	---	68.20	16.26	100.0	V	221.0	-4
2754.666667	---	41.93	54.00	12.07	200.0	V	209.0	-4
2941.100000	52.05	---	68.20	16.15	200.0	H	0.0	-3
3926.700000	---	43.28	54.00	10.72	100.0	V	248.0	-2
5155.200000	55.32	---	68.20	12.88	100.0	V	276.0	2
5362.633333	---	45.59	54.00	8.41	200.0	V	0.0	3
7578.366667	---	48.68	54.00	5.32	100.0	V	329.0	7
7756.400000	58.81	---	68.20	9.39	200.0	H	328.0	7

Remark: 1. Correction Factor = Antenna factor+ Insertion loss (cable loss + amplifier gain)

802.11n (HT20) CH140

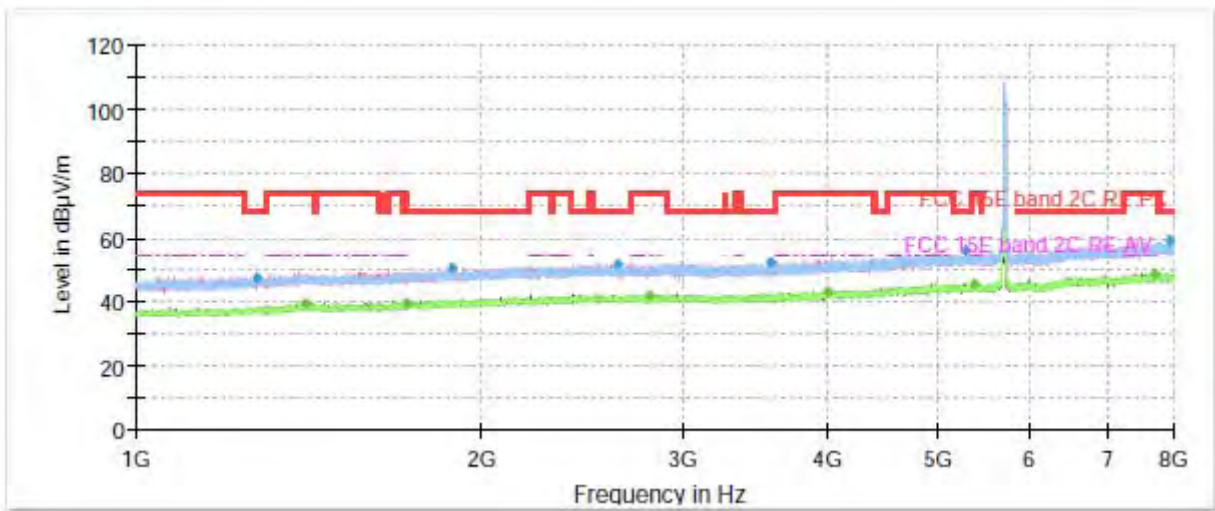

Note: The signal beyond the limit is carrier.
Radiates Emission from 1GHz to 8GHz

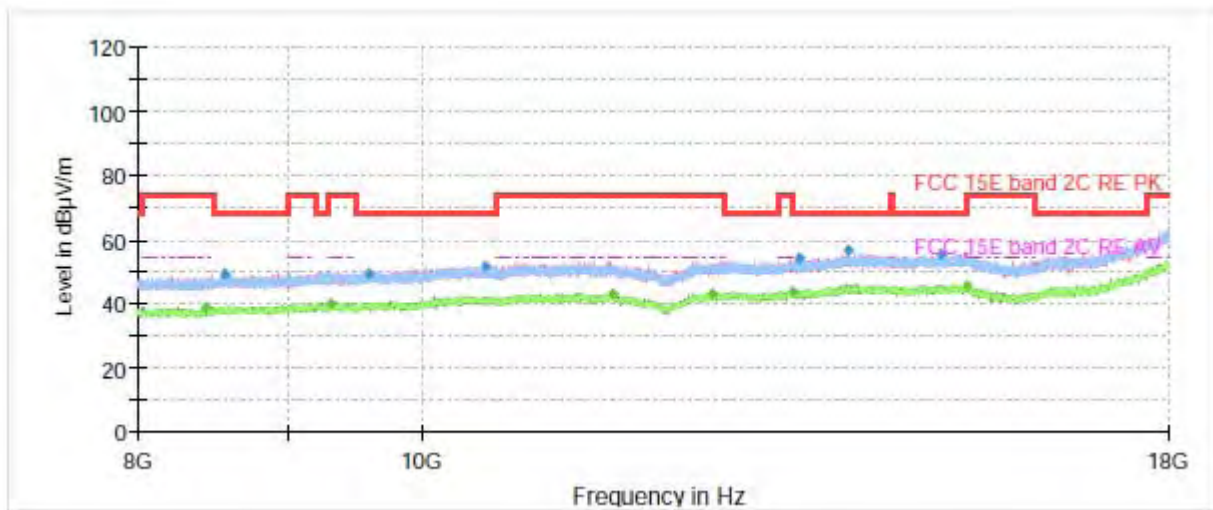

Radiates Emission from 8GHz to 18GHz



Frequency (MHz)	Peak (dBuV/m)	Average (dBuV/m)	Limit (dBuV/m)	Margin (dB)	Height (cm)	Polarization	Azimuth (deg)	Correct Factor (dB)
1273.233333	47.66	---	68.20	20.54	100.0	H	0.0	-8
1404.133333	---	39.36	54.00	14.64	100.0	V	263.0	-7
1721.000000	---	39.60	54.00	14.40	200.0	V	278.0	-6
1884.333333	50.68	---	68.20	17.52	200.0	V	235.0	-5
2620.733333	51.91	---	68.20	16.29	100.0	V	41.0	-4
2795.966667	---	42.03	54.00	11.97	100.0	V	353.0	-4
3565.500000	52.49	---	68.20	15.71	100.0	H	6.0	-3
3997.166667	---	43.01	54.00	10.99	100.0	V	11.0	-1
5272.100000	56.03	---	68.20	12.17	100.0	V	356.0	2
5374.533333	---	45.79	54.00	8.21	100.0	H	18.0	3
7688.266667	---	48.87	54.00	5.13	100.0	H	40.0	7
7920.200000	59.11	---	68.20	9.09	100.0	V	0.0	7

Remark: 1. Correction Factor = Antenna factor+ Insertion loss (cable loss + amplifier gain)



802.11n (HT20) CH144

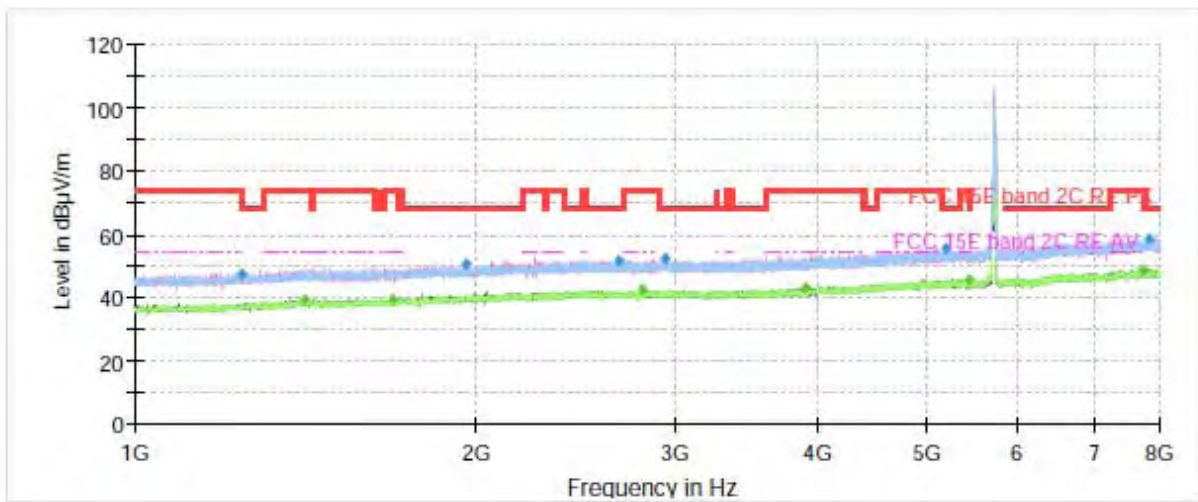

Note: The signal beyond the limit is carrier.
Radiates Emission from 1GHz to 8GHz

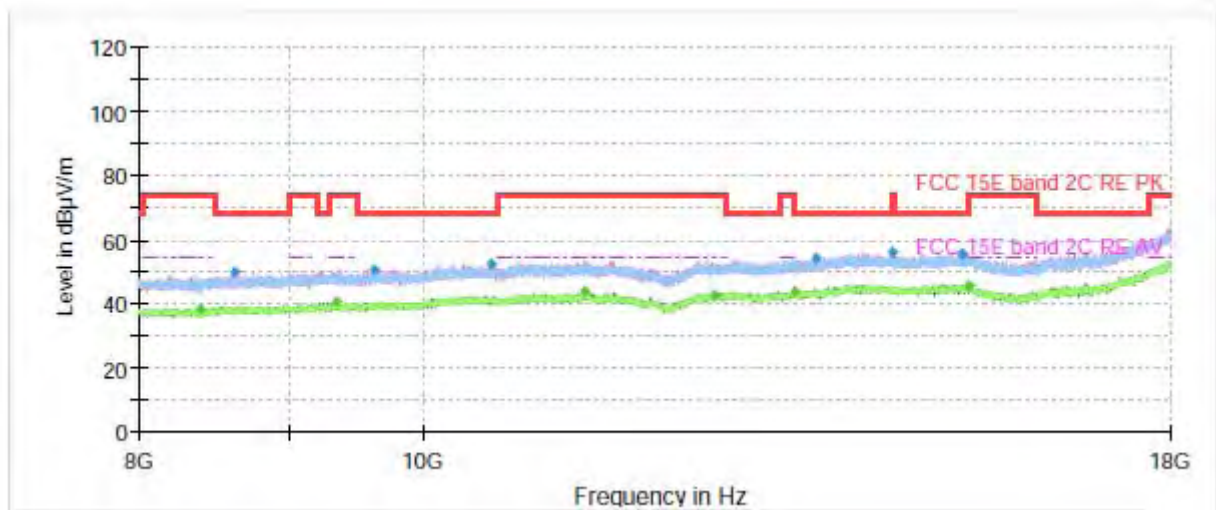

Radiates Emission from 8GHz to 18GHz



Frequency (MHz)	Peak (dBuV/m)	Average (dBuV/m)	Limit (dBuV/m)	Margin (dB)	Height (cm)	Polarization	Azimuth (deg)	Correct Factor (dB)
1244.533333	47.57	---	68.20	20.63	100.0	H	61.0	-8
1413.933333	---	39.15	54.00	14.85	100.0	V	0.0	-7
1687.400000	---	39.51	54.00	14.49	100.0	V	328.0	-6
1961.566667	50.33	---	68.20	17.87	100.0	H	154.0	-5
2672.300000	51.80	---	68.20	16.40	200.0	V	0.0	-3
2796.433333	---	42.39	54.00	11.61	200.0	V	5.0	-4
2937.600000	52.60	---	68.20	15.60	200.0	H	232.0	-3
3905.233333	---	43.23	54.00	10.77	100.0	V	192.0	-2
5177.833333	55.69	---	68.20	12.51	200.0	V	23.0	2
5431.466667	---	45.77	54.00	8.23	200.0	V	223.0	3
7725.600000	---	48.85	54.00	5.15	200.0	H	0.0	7
7846.933333	58.57	---	68.20	9.63	100.0	H	5.0	7

Remark: 1. Correction Factor = Antenna factor+ Insertion loss (cable loss + amplifier gain)



802.11n (HT20) CH149

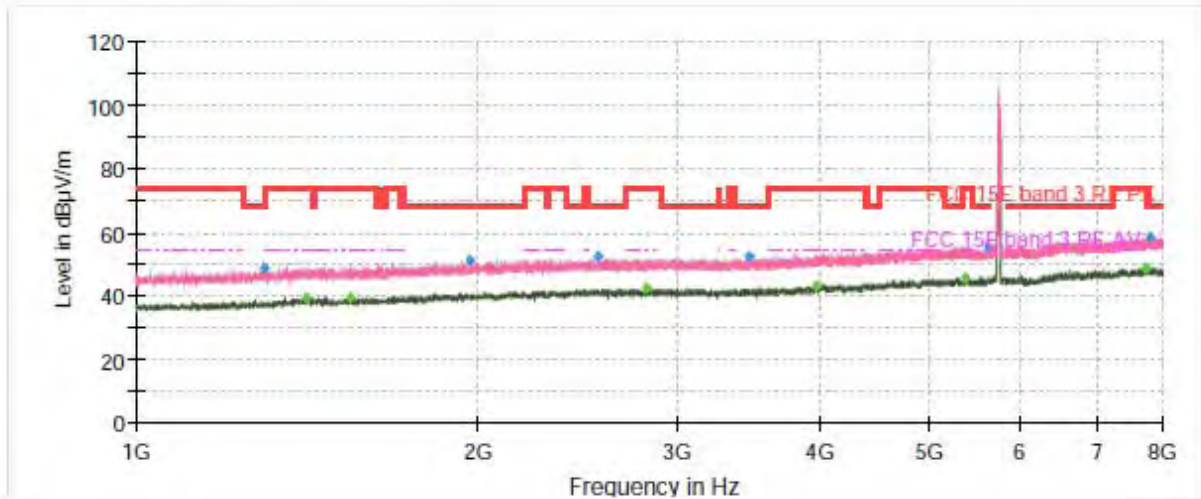

Note: The signal beyond the limit is carrier.
Radiates Emission from 1GHz to 8GHz

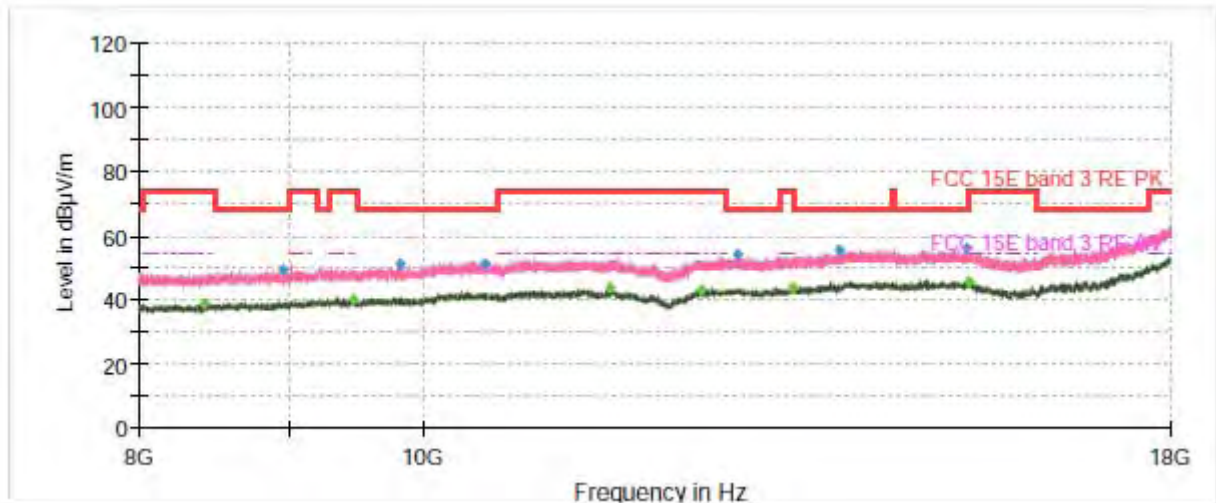

Radiates Emission from 8GHz to 18GHz



Frequency (MHz)	Peak (dBuV/m)	Average (dBuV/m)	Limit (dBuV/m)	Margin (dB)	Height (cm)	Polarization	Azimuth (deg)	Correct Factor (dB)
1298.900000	48.44	---	68.20	19.76	200.0	V	107.0	-8
1411.366667	---	39.37	54.00	14.63	200.0	H	79.0	-7
1540.866667	---	39.65	54.00	14.35	100.0	V	252.0	-7
1966.700000	50.89	---	68.20	17.31	100.0	V	132.0	-5
2545.133333	52.26	---	68.20	15.94	100.0	V	25.0	-4
2807.166667	---	42.53	54.00	11.47	100.0	H	192.0	-3
3458.866667	52.19	---	68.20	16.01	200.0	H	0.0	-3
3958.433333	---	43.24	54.00	10.76	100.0	H	0.0	-1
5371.966667	---	45.56	54.00	8.44	100.0	H	259.0	3
5609.733333	55.49	---	68.20	12.71	200.0	V	0.0	3
7732.600000	---	48.69	54.00	5.31	100.0	H	344.0	7
7789.766667	58.75	---	68.20	9.45	100.0	H	272.0	7

Remark: 1. Correction Factor = Antenna factor+ Insertion loss (cable loss + amplifier gain)

802.11n (HT20) CH157

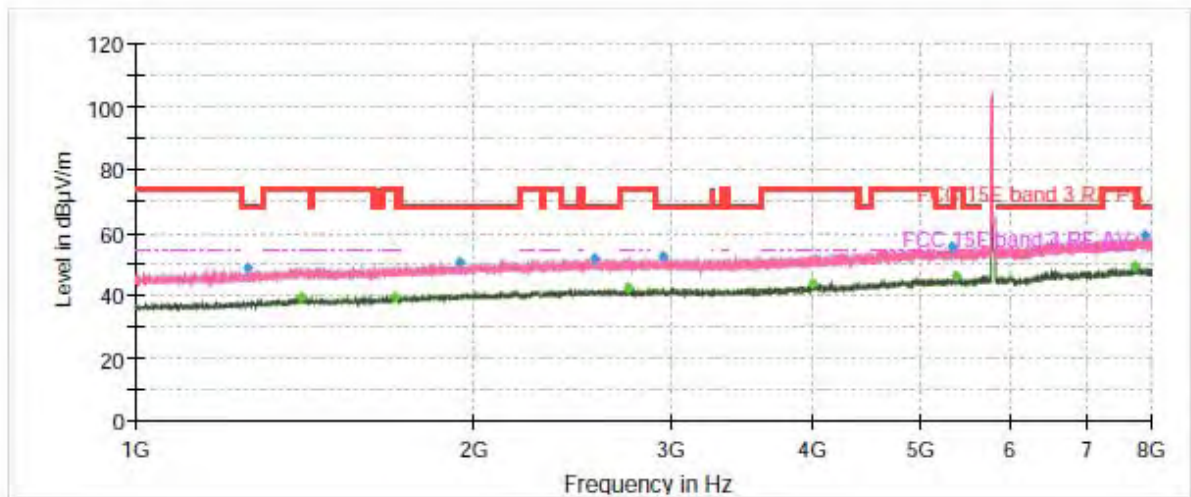

Note: The signal beyond the limit is carrier.
Radiates Emission from 1GHz to 8GHz

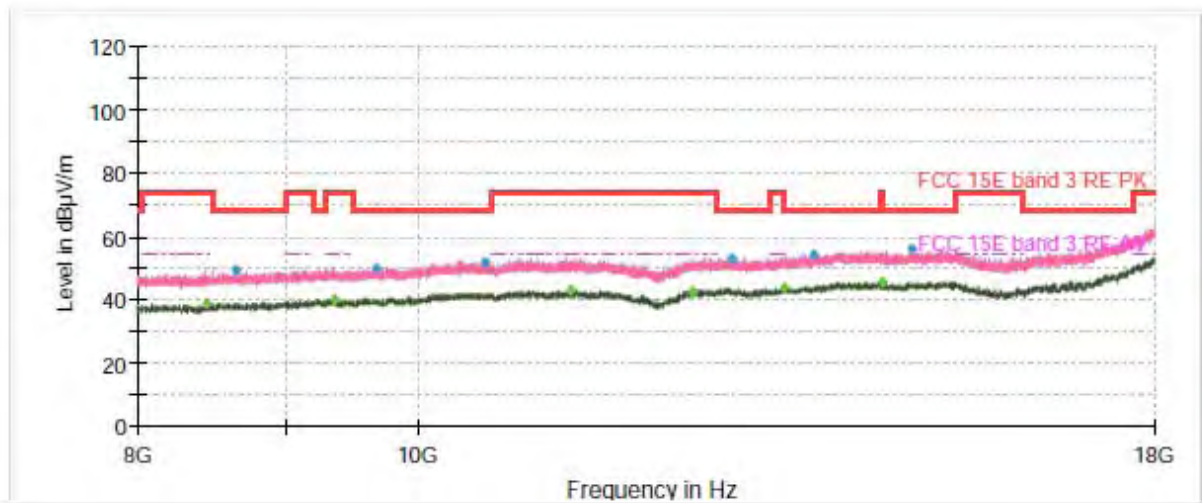

Radiates Emission from 8GHz to 18GHz



Frequency (MHz)	Peak (dBuV/m)	Average (dBuV/m)	Limit (dBuV/m)	Margin (dB)	Height (cm)	Polarization	Azimuth (deg)	Correct Factor (dB)
1258.066667	48.54	---	68.20	19.66	100.0	V	2.0	-8
1404.133333	---	39.58	54.00	14.42	200.0	V	123.0	-7
1702.566667	---	39.63	54.00	14.37	100.0	H	240.0	-6
1944.533333	50.28	---	68.20	17.92	200.0	H	10.0	-5
2559.833333	51.84	---	68.20	16.36	200.0	V	355.0	-4
2740.433333	---	42.18	54.00	11.82	100.0	H	358.0	-4
2948.800000	52.61	---	68.20	15.59	100.0	V	198.0	-3
3992.733333	---	43.48	54.00	10.52	100.0	V	6.0	-1
5314.100000	55.63	---	68.20	12.57	200.0	V	68.0	2
5373.833333	---	46.04	54.00	7.96	100.0	V	171.0	3
7744.500000	---	48.98	54.00	5.02	100.0	H	322.0	7
7895.233333	58.93	---	68.20	9.27	200.0	H	0.0	7

Remark: 1. Correction Factor = Antenna factor+ Insertion loss (cable loss + amplifier gain)



802.11n (HT20) CH165

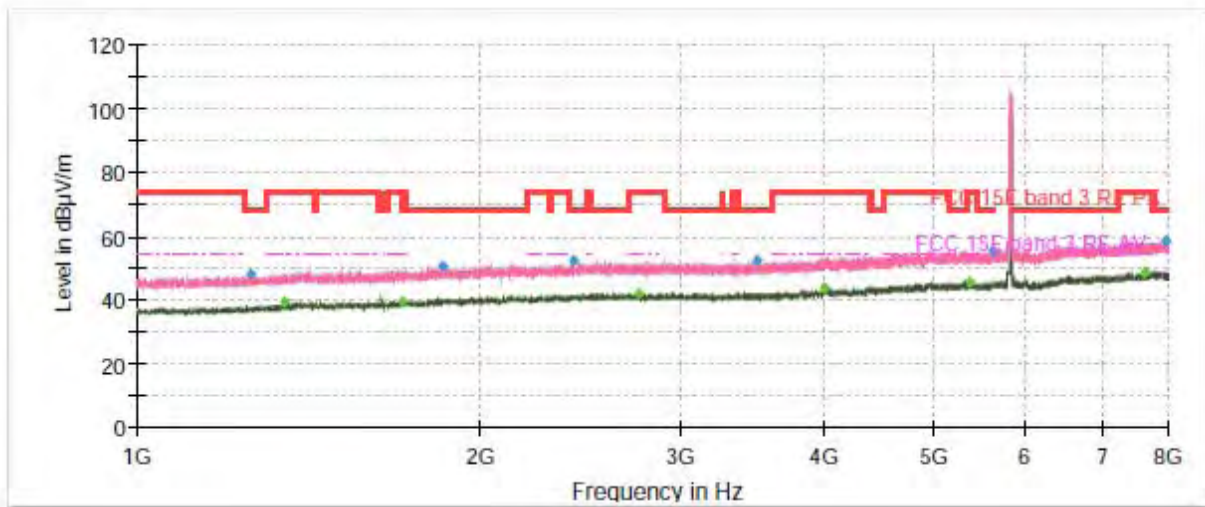

Note: The signal beyond the limit is carrier.
Radiates Emission from 1GHz to 8GHz

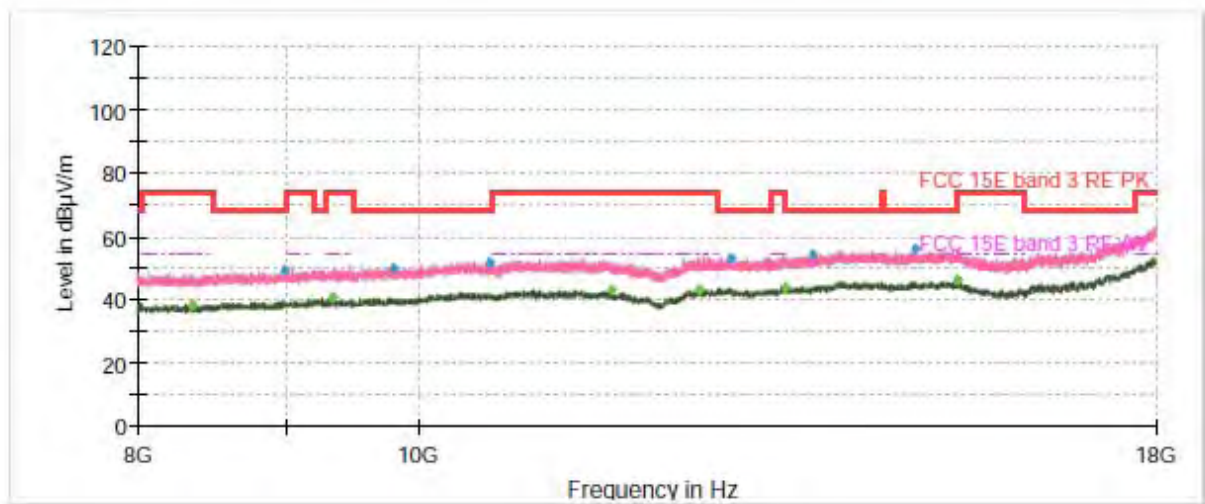

Radiates Emission from 8GHz to 18GHz



Frequency (MHz)	Peak (dBuV/m)	Average (dBuV/m)	Limit (dBuV/m)	Margin (dB)	Height (cm)	Polarization	Azimuth (deg)	Correct Factor (dB)
1258.300000	48.16	---	68.20	20.04	100.0	H	10.0	-8
1349.066667	---	39.41	54.00	14.59	100.0	V	2.0	-7
1709.566667	---	39.57	54.00	14.43	200.0	H	293.0	-6
1850.266667	50.45	---	68.20	17.75	200.0	V	343.0	-5
2409.566667	52.21	---	68.20	15.99	200.0	H	198.0	-4
2751.866667	---	42.02	54.00	11.98	200.0	H	45.0	-4
3493.633333	52.56	---	68.20	15.64	200.0	H	58.0	-3
3996.466667	---	43.59	54.00	10.41	100.0	H	122.0	-1
5368.466667	---	45.56	54.00	8.44	100.0	H	0.0	3
5627.233333	55.60	---	68.20	12.60	100.0	H	241.0	3
7632.733333	---	48.72	54.00	5.28	200.0	H	210.0	7
7952.866667	58.37	---	68.20	9.83	200.0	V	256.0	8

Remark: 1. Correction Factor = Antenna factor+ Insertion loss (cable loss + amplifier gain)



802.11n (HT40) CH38

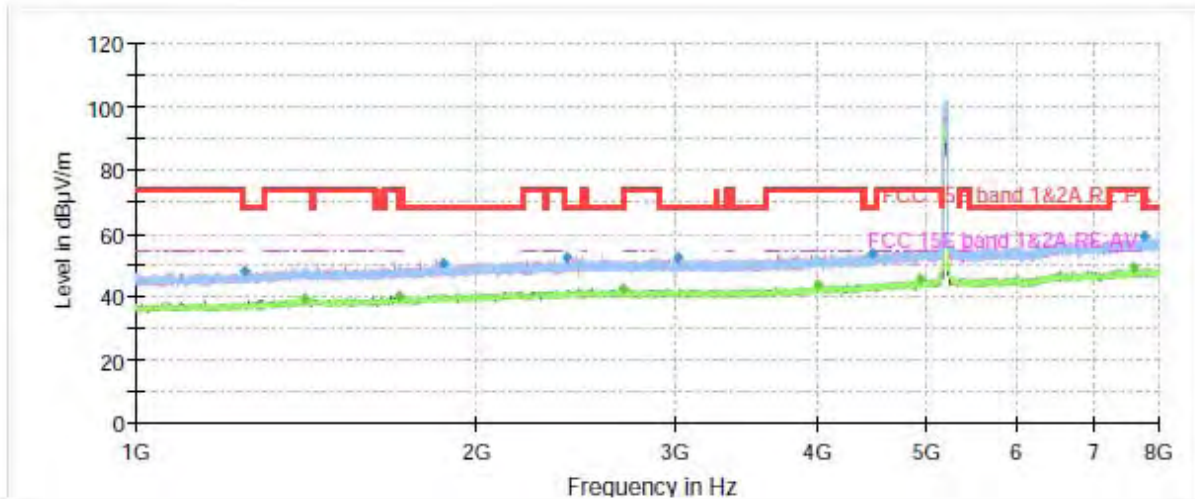

Note: The signal beyond the limit is carrier.
Radiates Emission from 1GHz to 8GHz

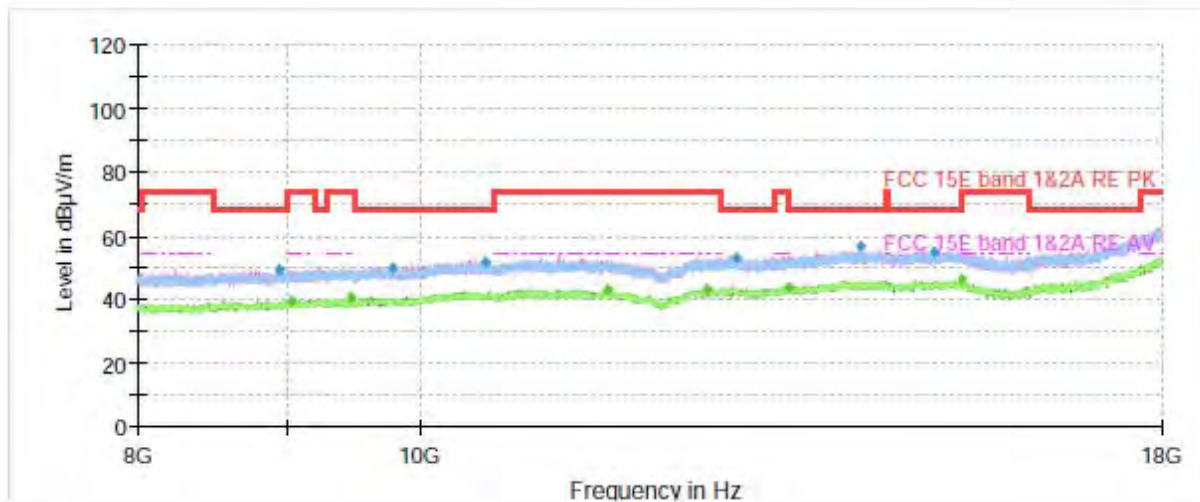

Radiates Emission from 8GHz to 18GHz



Frequency (MHz)	Peak (dBuV/m)	Average (dBuV/m)	Limit (dBuV/m)	Margin (dB)	Height (cm)	Polarization	Azimuth (deg)	Correct Factor (dB)
1246.633333	48.29	---	68.20	19.91	100.0	H	321.0	-8
1409.500000	---	39.57	54.00	14.43	200.0	V	233.0	-7
1709.566667	---	39.79	54.00	14.21	100.0	H	168.0	-6
1867.533333	50.38	---	68.20	17.82	200.0	H	355.0	-5
2400.233333	52.14	---	68.20	16.06	200.0	V	0.0	-4
2690.733333	---	42.41	54.00	11.59	200.0	H	123.0	-4
3005.033333	52.23	---	68.20	15.97	200.0	H	0.0	-3
3997.400000	---	43.64	54.00	10.36	200.0	H	352.0	-1
4471.300000	53.47	---	68.20	14.73	200.0	H	355.0	0
4929.333333	---	45.82	54.00	8.18	100.0	H	10.0	2
7604.266667	---	49.00	54.00	5.00	100.0	H	236.0	7
7761.766667	59.29	---	68.20	8.91	100.0	H	1.0	7

Remark: 1. Correction Factor = Antenna factor+ Insertion loss (cable loss + amplifier gain)

802.11n (HT40) CH46

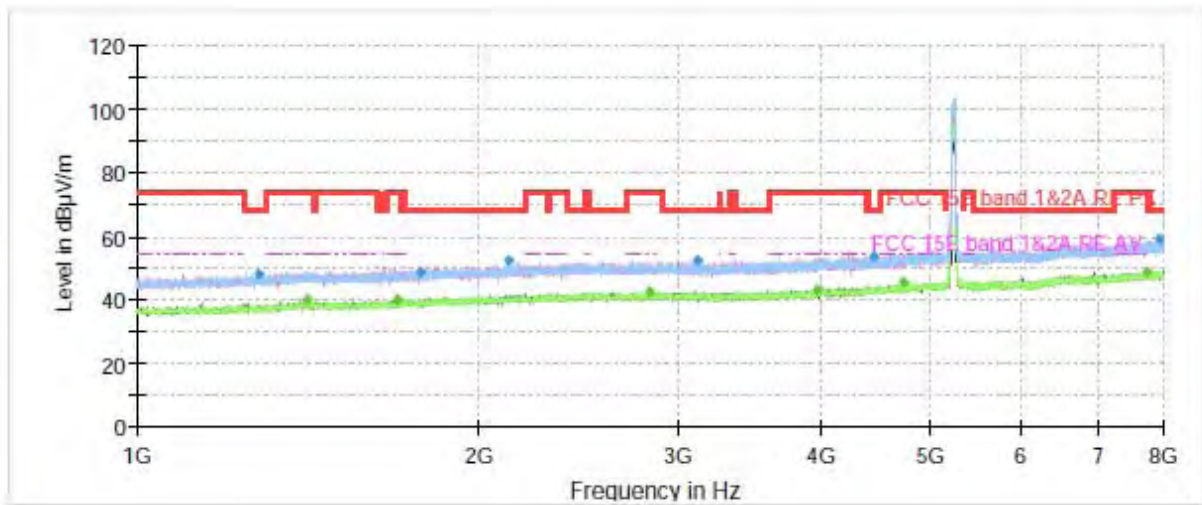

Note: The signal beyond the limit is carrier.
Radiates Emission from 1GHz to 8GHz

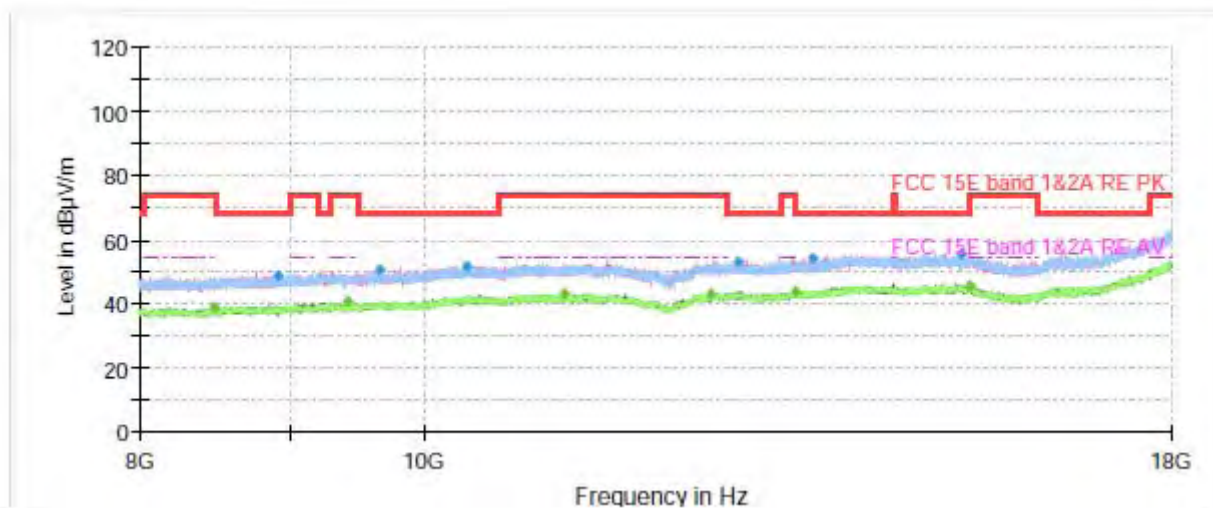

Radiates Emission from 8GHz to 18GHz



Frequency (MHz)	Peak (dBuV/m)	Average (dBuV/m)	Limit (dBuV/m)	Margin (dB)	Height (cm)	Polarization	Azimuth (deg)	Correct Factor (dB)
1277.200000	48.29	---	68.20	19.91	200.0	V	25.0	-8
1412.533333	---	39.82	54.00	14.18	100.0	V	234.0	-7
1692.300000	---	39.80	54.00	14.20	100.0	H	1.0	-6
1778.633333	48.89	---	68.20	19.31	200.0	V	76.0	-6
2124.666667	52.38	---	68.20	15.82	200.0	H	263.0	-4
2823.966667	---	42.61	54.00	11.39	200.0	V	291.0	-3
3107.933333	52.38	---	68.20	15.82	100.0	V	351.0	-3
3973.366667	---	43.04	54.00	10.96	200.0	H	359.0	-1
4446.800000	53.28	---	68.20	14.92	100.0	H	87.0	0
4717.466667	---	45.66	54.00	8.34	200.0	V	306.0	1
7742.633333	---	48.67	54.00	5.33	100.0	H	87.0	7
7937.000000	58.84	---	68.20	9.36	100.0	H	61.0	8

Remark: 1. Correction Factor = Antenna factor+ Insertion loss (cable loss + amplifier gain)

802.11n (HT40) CH54

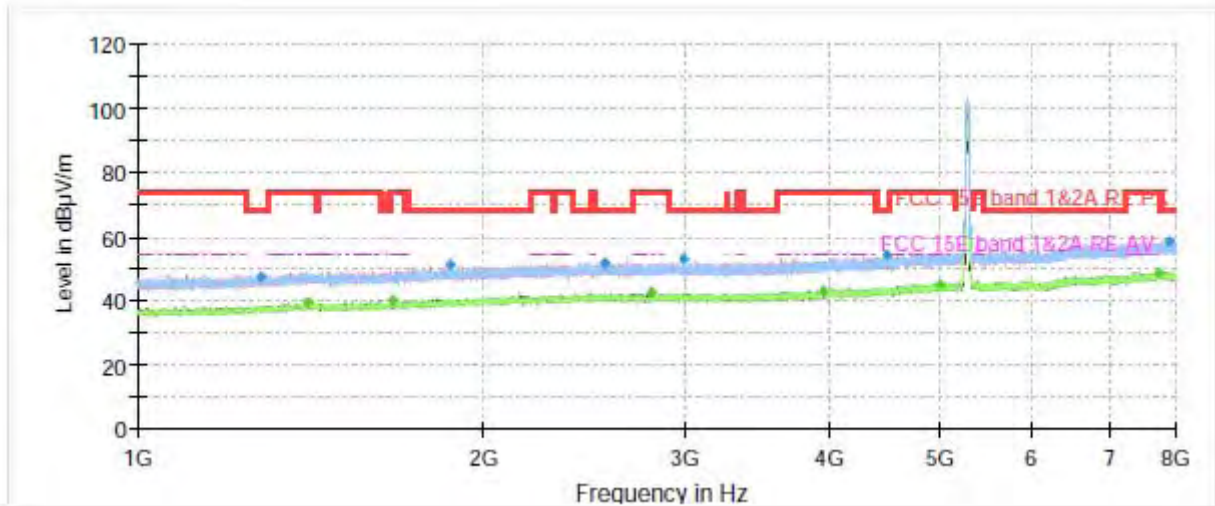

Note: The signal beyond the limit is carrier.
Radiates Emission from 1GHz to 8GHz

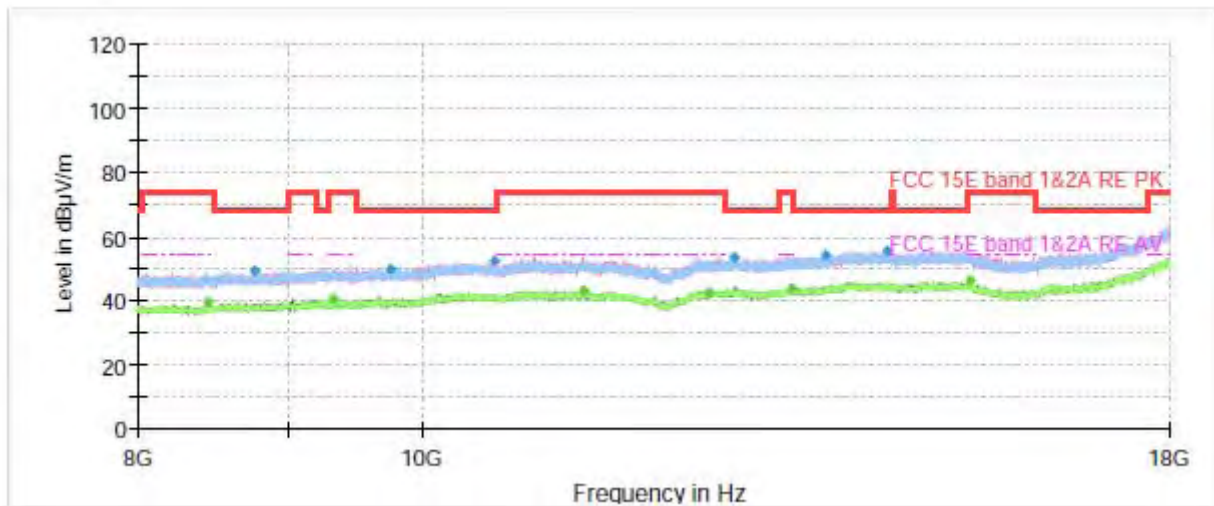

Radiates Emission from 8GHz to 18GHz



Frequency (MHz)	Peak (dBuV/m)	Average (dBuV/m)	Limit (dBuV/m)	Margin (dB)	Height (cm)	Polarization	Azimuth (deg)	Correct Factor (dB)
1278.133333	47.45	---	68.20	20.75	100.0	V	136.0	-8
1404.133333	---	39.36	54.00	14.64	200.0	V	292.0	-7
1663.366667	---	39.91	54.00	14.09	200.0	V	0.0	-6
1865.200000	50.82	---	68.20	17.38	100.0	V	349.0	-5
2550.733333	51.86	---	68.20	16.34	200.0	H	359.0	-4
2800.866667	---	42.20	54.00	11.80	200.0	H	357.0	-3
2982.166667	52.74	---	68.20	15.46	100.0	V	230.0	-3
3952.600000	---	43.29	54.00	10.71	100.0	V	269.0	-1
4482.733333	54.32	---	68.20	13.88	200.0	H	355.0	0
4988.133333	---	45.21	54.00	8.79	200.0	V	73.0	2
7726.300000	---	48.84	54.00	5.16	200.0	H	138.0	7
7883.566667	58.57	---	68.20	9.63	100.0	V	321.0	7

Remark: 1. Correction Factor = Antenna factor+ Insertion loss (cable loss + amplifier gain)



802.11n (HT40) CH62

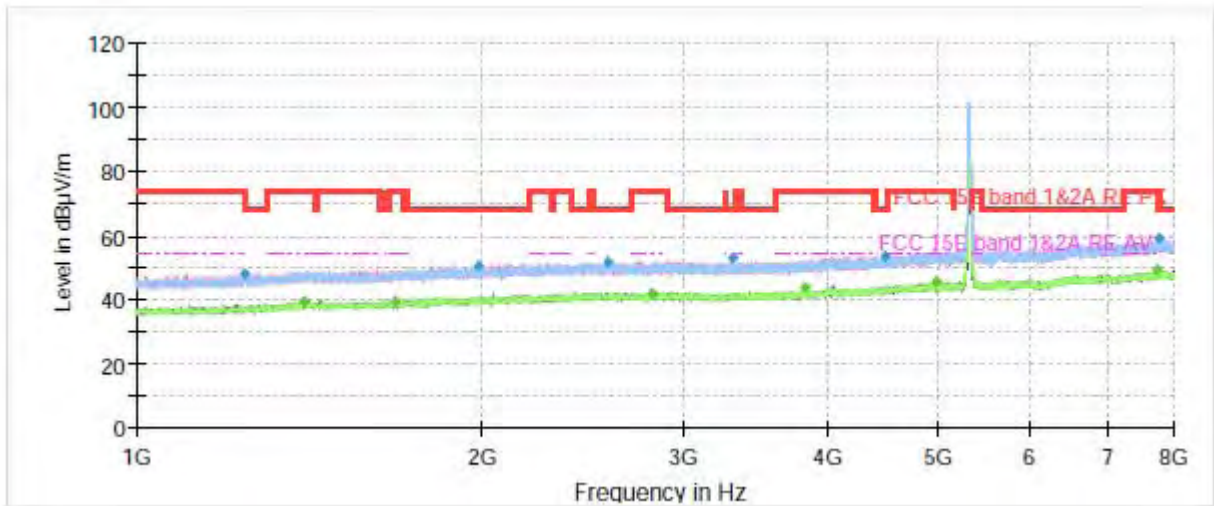

Note: The signal beyond the limit is carrier.
Radiates Emission from 1GHz to 8GHz

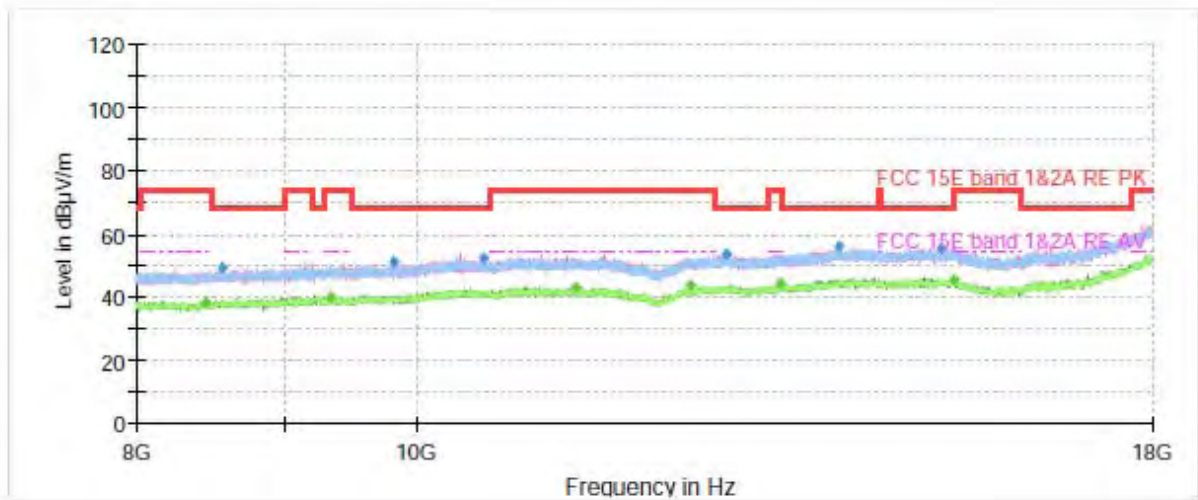

Radiates Emission from 8GHz to 18GHz



Frequency (MHz)	Peak (dBuV/m)	Average (dBuV/m)	Limit (dBuV/m)	Margin (dB)	Height (cm)	Polarization	Azimuth (deg)	Correct Factor (dB)
1243.833333	48.12	---	68.20	20.08	200.0	H	359.0	-8
1401.100000	---	39.42	54.00	14.58	200.0	V	278.0	-7
1678.766667	---	39.50	54.00	14.50	100.0	V	39.0	-6
1983.266667	50.69	---	68.20	17.51	200.0	V	44.0	-5
2570.566667	51.95	---	68.20	16.25	200.0	H	178.0	-4
2806.933333	---	41.88	54.00	12.12	100.0	V	136.0	-3
3310.000000	52.84	---	68.20	15.36	200.0	V	44.0	-3
3819.133333	---	43.70	54.00	10.30	200.0	V	321.0	-2
4488.100000	53.67	---	68.20	14.54	100.0	H	156.0	0
4972.500000	---	45.61	54.00	8.39	100.0	V	10.0	2
7732.133333	---	49.09	54.00	4.91	100.0	H	225.0	7
7750.333333	59.15	---	68.20	9.05	100.0	V	164.0	7

Remark: 1. Correction Factor = Antenna factor+ Insertion loss (cable loss + amplifier gain)

802.11n (HT40) CH102

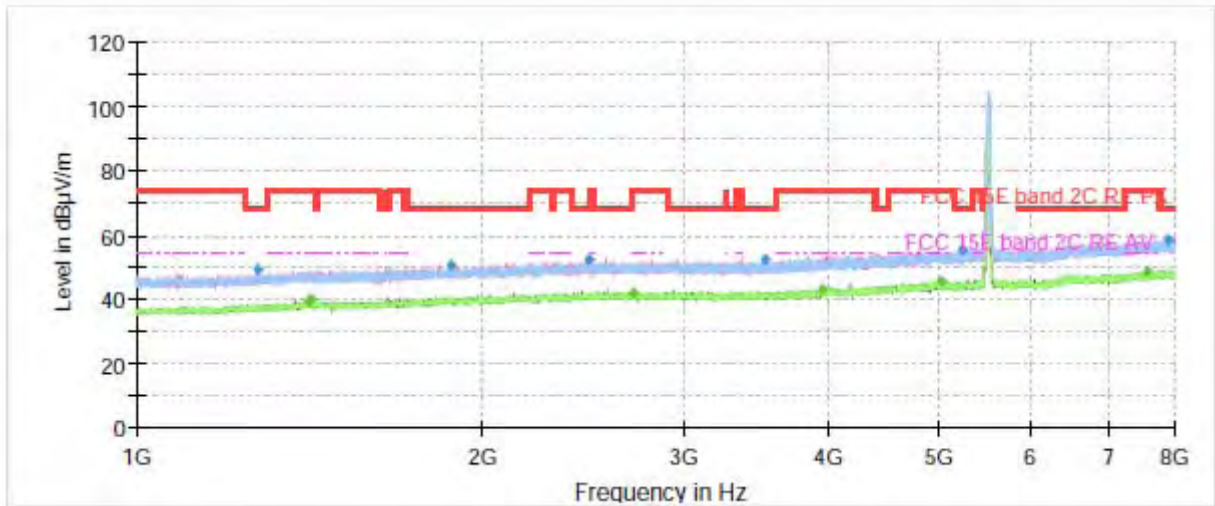

Note: The signal beyond the limit is carrier.
Radiates Emission from 1GHz to 8GHz

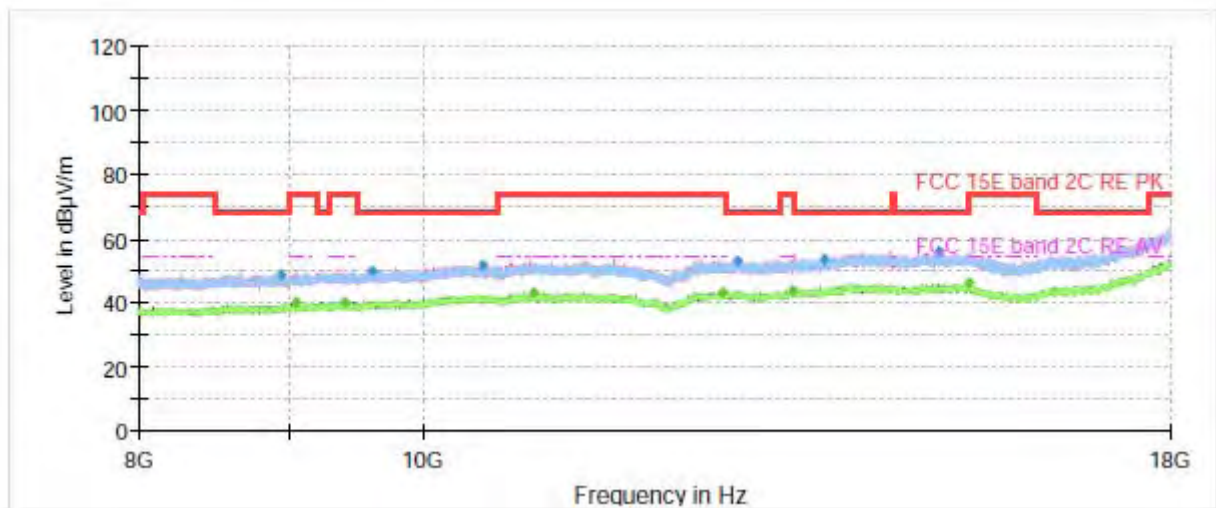

Radiates Emission from 8GHz to 18GHz



Frequency (MHz)	Peak (dBuV/m)	Average (dBuV/m)	Limit (dBuV/m)	Margin (dB)	Height (cm)	Polarization	Azimuth (deg)	Correct Factor (dB)
1274.166667	49.07	---	68.20	19.13	100.0	V	162.0	-8
1411.833333	---	39.40	54.00	14.60	100.0	V	0.0	-7
1416.500000	---	39.78	54.00	14.22	100.0	H	209.0	-7
1875.233333	50.59	---	68.20	17.61	200.0	H	0.0	-5
2471.866667	52.19	---	68.20	16.01	100.0	V	0.0	-4
2710.333333	---	41.87	54.00	12.13	100.0	V	326.0	-4
3520.233333	52.41	---	68.20	15.79	200.0	H	1.0	-3
3953.766667	---	43.17	54.00	10.83	100.0	H	278.0	-1
5020.800000	---	45.52	54.00	8.48	200.0	V	24.0	2
5223.100000	55.63	---	68.20	12.57	200.0	V	2.0	2
7583.033333	---	48.78	54.00	5.22	200.0	V	350.0	7
7895.466667	58.41	---	68.20	9.79	200.0	V	210.0	7

Remark: 1. Correction Factor = Antenna factor+ Insertion loss (cable loss + amplifier gain)

802.11n (HT40) CH118

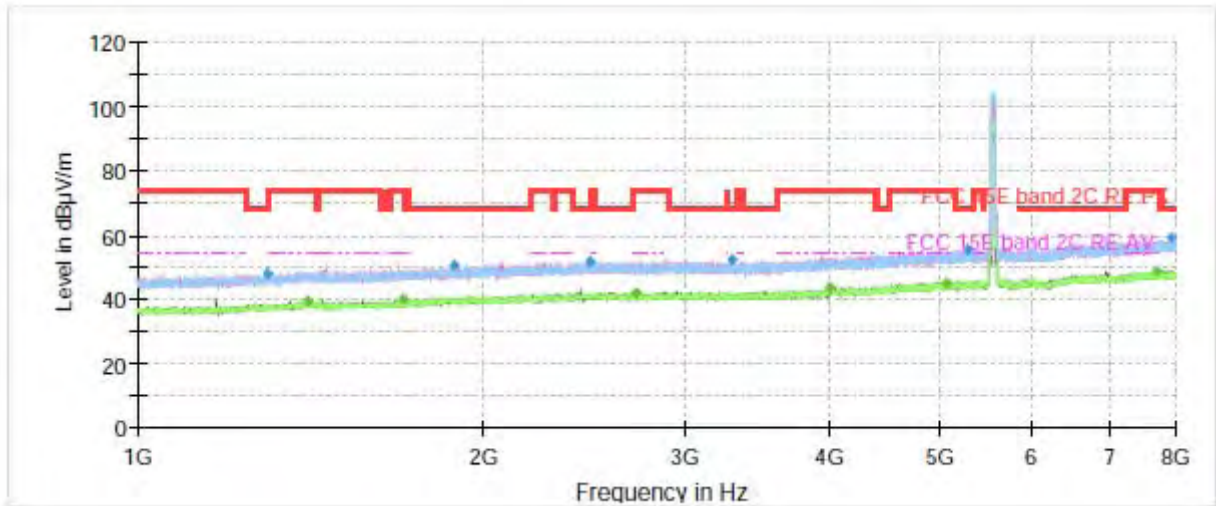

Note: The signal beyond the limit is carrier.
Radiates Emission from 1GHz to 8GHz

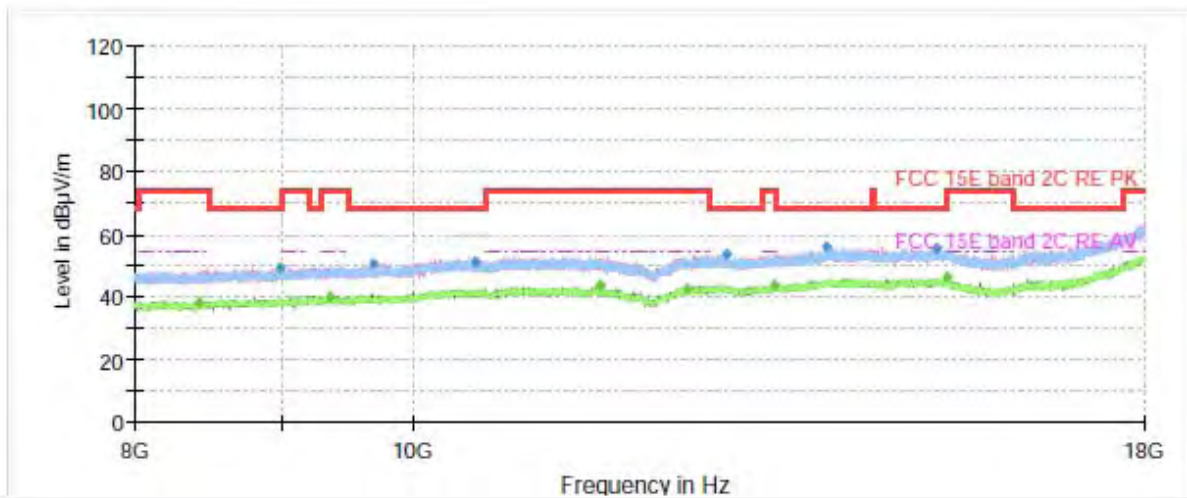

Radiates Emission from 8GHz to 18GHz



Frequency (MHz)	Peak (dBuV/m)	Average (dBuV/m)	Limit (dBuV/m)	Margin (dB)	Height (cm)	Polarization	Azimuth (deg)	Correct Factor (dB)
1298.433333	47.92	---	68.20	20.28	100.0	H	156.0	-8
1408.100000	---	39.47	54.00	14.53	100.0	H	1.0	-7
1704.433333	---	40.08	54.00	13.92	200.0	V	205.0	-6
1882.233333	50.69	---	68.20	17.51	100.0	H	16.0	-5
2471.400000	51.56	---	68.20	16.64	100.0	H	238.0	-4
2716.400000	---	41.86	54.00	12.14	200.0	V	177.0	-4
3284.333333	52.26	---	68.20	15.94	200.0	H	356.0	-3
3997.866667	---	43.94	54.00	10.06	100.0	V	0.0	-1
5049.033333	---	45.19	54.00	8.81	100.0	V	243.0	2
5269.300000	55.37	---	68.20	12.83	100.0	H	16.0	2
7699.000000	---	48.52	54.00	5.48	200.0	H	149.0	7
7931.166667	59.06	---	68.20	9.14	200.0	H	80.0	7

Remark: 1. Correction Factor = Antenna factor+ Insertion loss (cable loss + amplifier gain)

802.11n (HT40) CH134

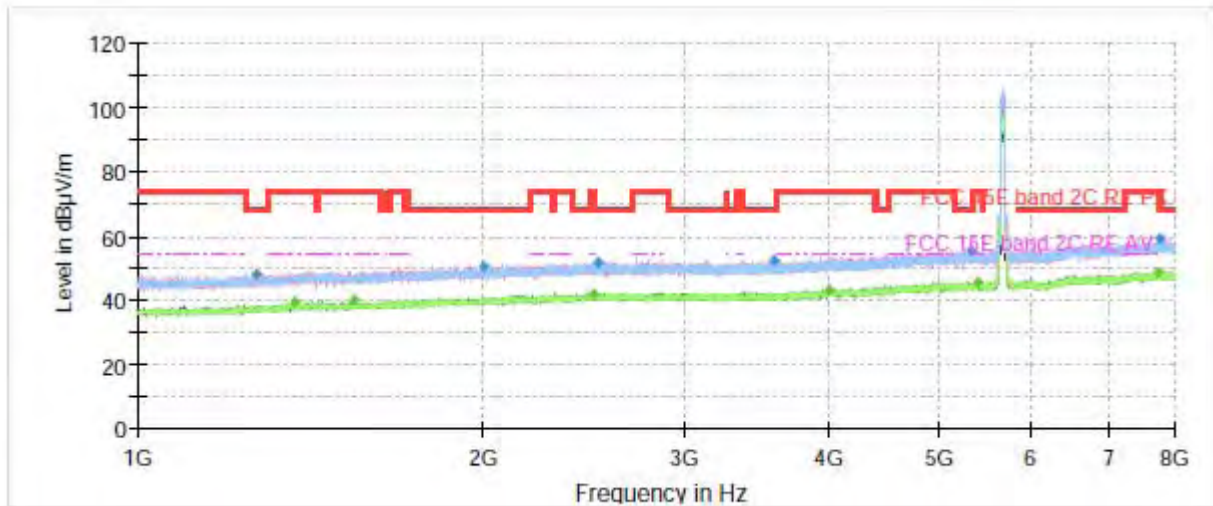

Note: The signal beyond the limit is carrier.
Radiates Emission from 1GHz to 8GHz

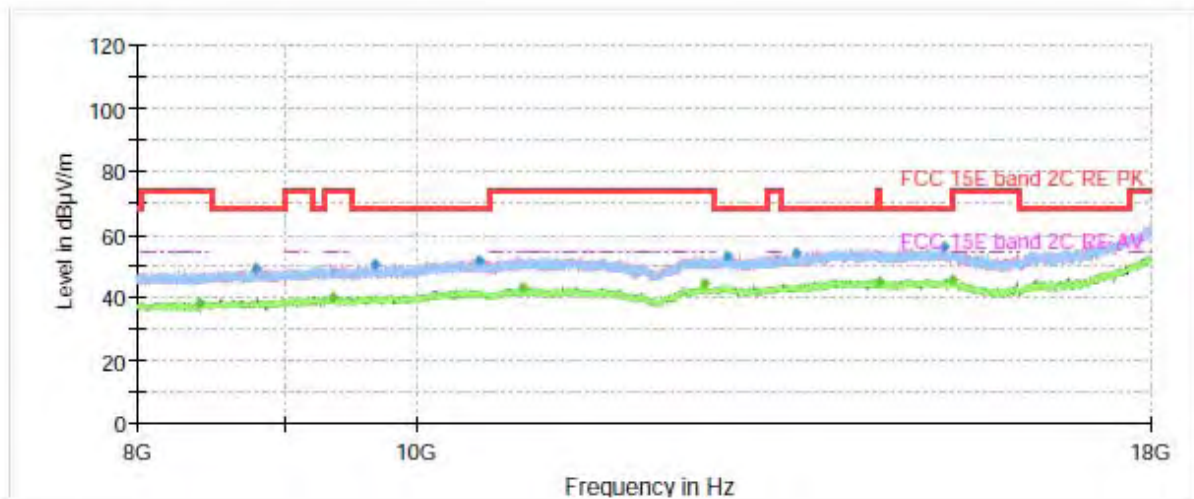

Radiates Emission from 8GHz to 18GHz



Frequency (MHz)	Peak (dBuV/m)	Average (dBuV/m)	Limit (dBuV/m)	Margin (dB)	Height (cm)	Polarization	Azimuth (deg)	Correct Factor (dB)
1271.133333	47.70	---	68.20	20.50	100.0	H	38.0	-8
1369.366667	---	39.27	54.00	14.73	200.0	H	10.0	-7
1539.933333	---	39.88	54.00	14.12	100.0	V	354.0	-7
1996.100000	50.62	---	68.20	17.58	200.0	V	1.0	-5
2494.500000	---	42.12	54.00	11.88	200.0	H	10.0	-4
2512.000000	51.75	---	68.20	16.45	100.0	V	350.0	-4
3577.166667	52.43	---	68.20	15.77	200.0	H	137.0	-3
3998.566667	---	43.25	54.00	10.75	200.0	V	292.0	-1
5318.300000	55.68	---	68.20	12.52	200.0	H	315.0	3
5395.066667	---	45.64	54.00	8.36	200.0	H	236.0	3
7743.100000	---	48.83	54.00	5.17	100.0	V	218.0	7
7775.300000	58.80	---	68.20	9.40	200.0	H	68.0	7

Remark: 1. Correction Factor = Antenna factor+ Insertion loss (cable loss + amplifier gain)

802.11n (HT40) CH142

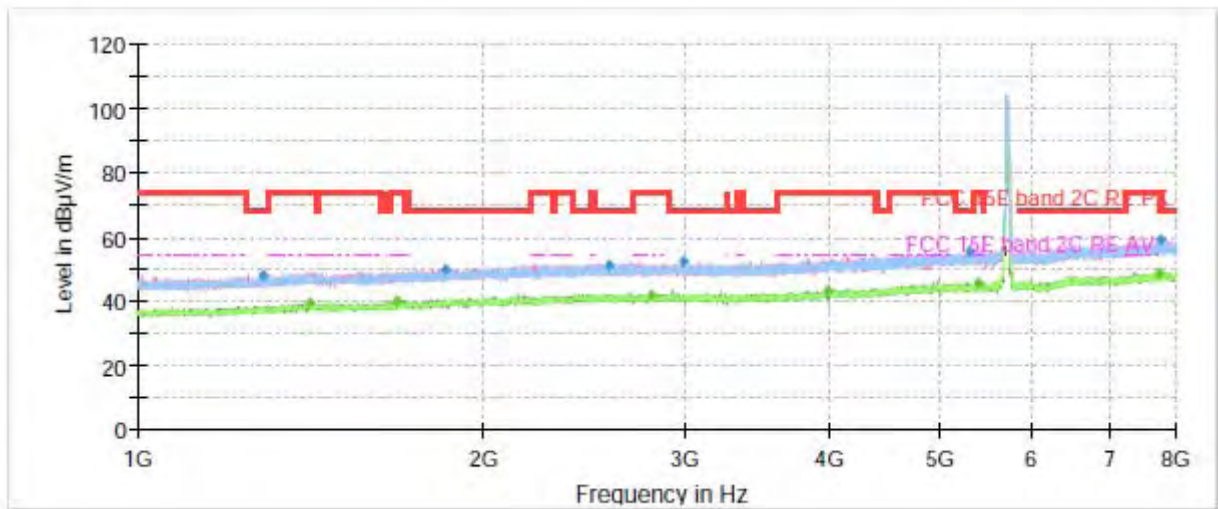

Note: The signal beyond the limit is carrier.
Radiates Emission from 1GHz to 8GHz

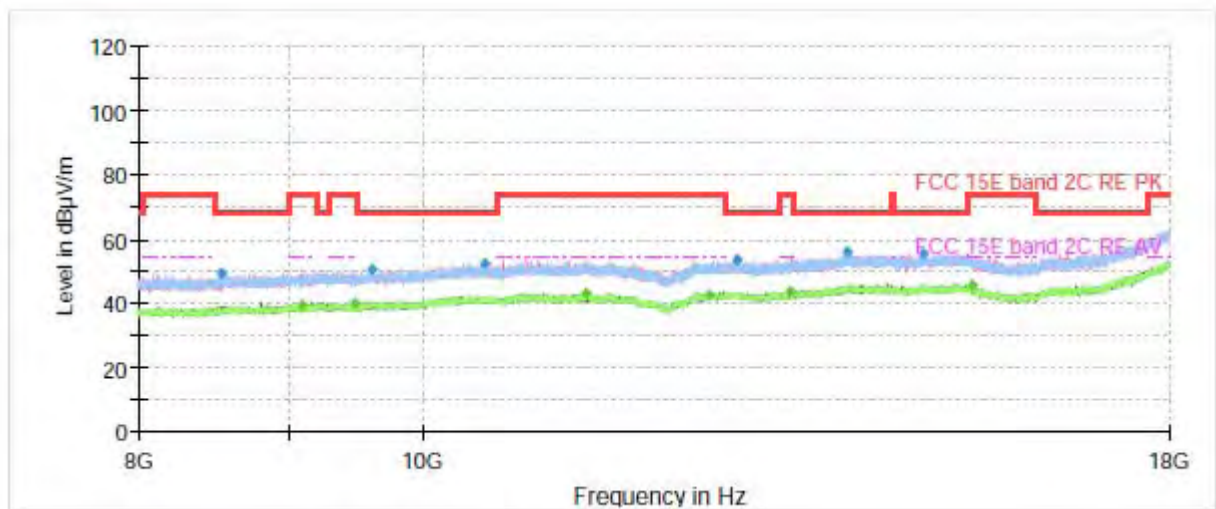

Radiates Emission from 8GHz to 18GHz



Frequency (MHz)	Peak (dBuV/m)	Average (dBuV/m)	Limit (dBuV/m)	Margin (dB)	Height (cm)	Polarization	Azimuth (deg)	Correct Factor (dB)
1285.366667	47.73	---	68.20	20.47	200.0	V	4.0	-8
1409.266667	---	39.36	54.00	14.64	200.0	V	29.0	-7
1679.233333	---	40.07	54.00	13.93	200.0	V	250.0	-6
1856.333333	50.05	---	68.20	18.15	200.0	H	166.0	-5
2566.600000	50.89	---	68.20	17.31	200.0	H	344.0	-4
2796.433333	---	41.92	54.00	12.08	100.0	V	346.0	-4
2984.266667	52.20	---	68.20	16.00	200.0	V	208.0	-3
3990.166667	---	43.29	54.00	10.71	100.0	H	13.0	-1
5306.400000	55.38	---	68.20	12.82	200.0	V	11.0	2
5396.933333	---	45.83	54.00	8.17	100.0	V	359.0	3
7748.700000	---	48.91	54.00	5.09	200.0	V	278.0	7
7768.533333	58.90	---	68.20	9.30	200.0	V	11.0	7

Remark: 1. Correction Factor = Antenna factor+ Insertion loss (cable loss + amplifier gain)

802.11n (HT40) CH151

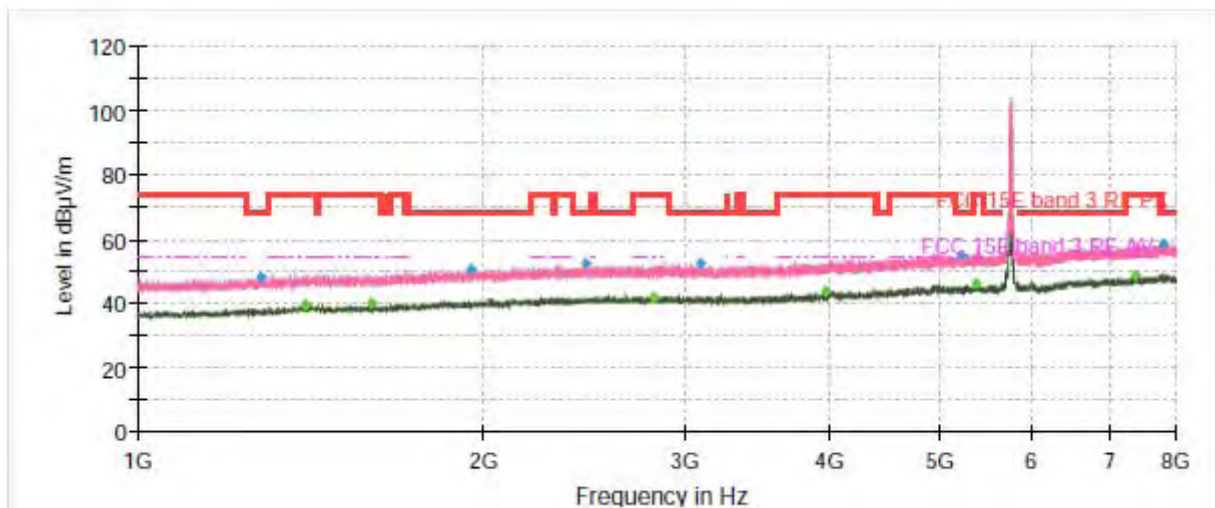

Note: The signal beyond the limit is carrier.
Radiates Emission from 1GHz to 8GHz

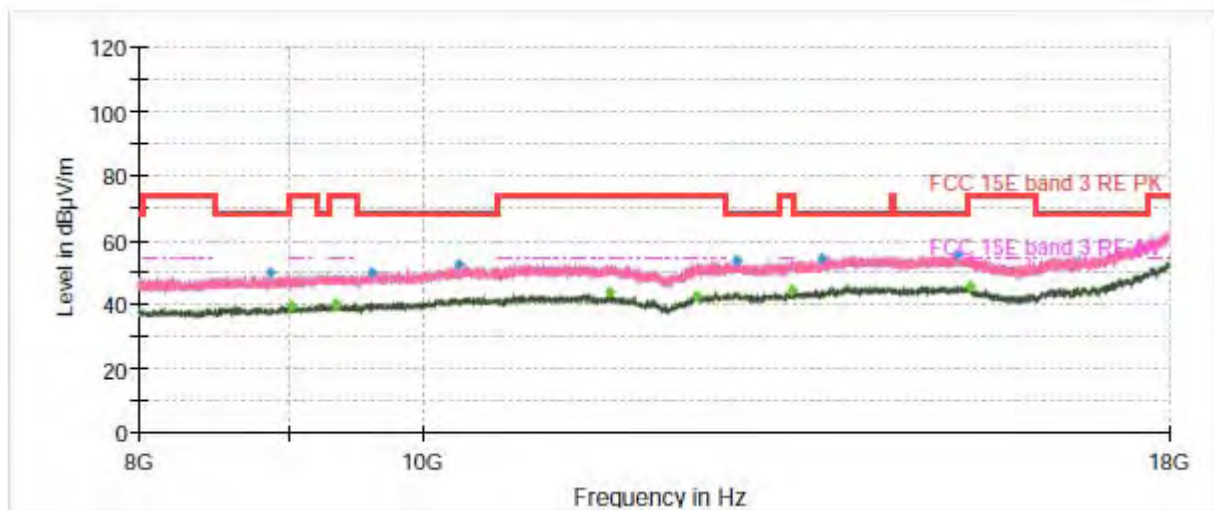

Radiates Emission from 8GHz to 18GHz



Frequency (MHz)	Peak (dBuV/m)	Average (dBuV/m)	Limit (dBuV/m)	Margin (dB)	Height (cm)	Polarization	Azimuth (deg)	Correct Factor (dB)
1277.900000	47.95	---	68.20	20.25	100.0	H	352.0	-8
1402.033333	---	39.68	54.00	14.32	200.0	H	170.0	-7
1596.633333	---	39.75	54.00	14.25	100.0	V	0.0	-6
1951.766667	50.34	---	68.20	17.86	200.0	H	1.0	-5
2455.766667	52.43	---	68.20	15.77	100.0	H	182.0	-4
2810.666667	---	42.03	54.00	11.97	200.0	V	100.0	-3
3084.600000	52.21	---	68.20	15.99	100.0	H	69.0	-3
3968.000000	---	43.44	54.00	10.56	100.0	H	0.0	-1
5208.633333	54.75	---	68.20	13.45	200.0	V	359.0	2
5368.933333	---	45.88	54.00	8.12	200.0	V	302.0	3
7378.400000	---	48.60	54.00	5.40	200.0	H	104.0	7
7793.733333	58.63	---	68.20	9.57	200.0	H	0.0	7

Remark: 1. Correction Factor = Antenna factor+ Insertion loss (cable loss + amplifier gain)

802.11n (HT40) CH159

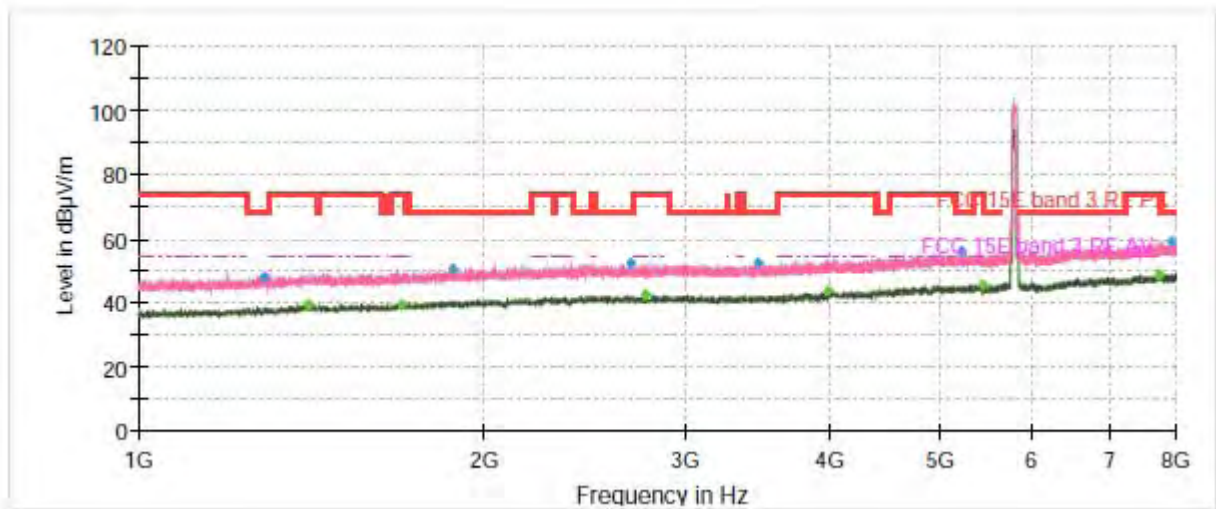

Note: The signal beyond the limit is carrier.
Radiates Emission from 1GHz to 8GHz

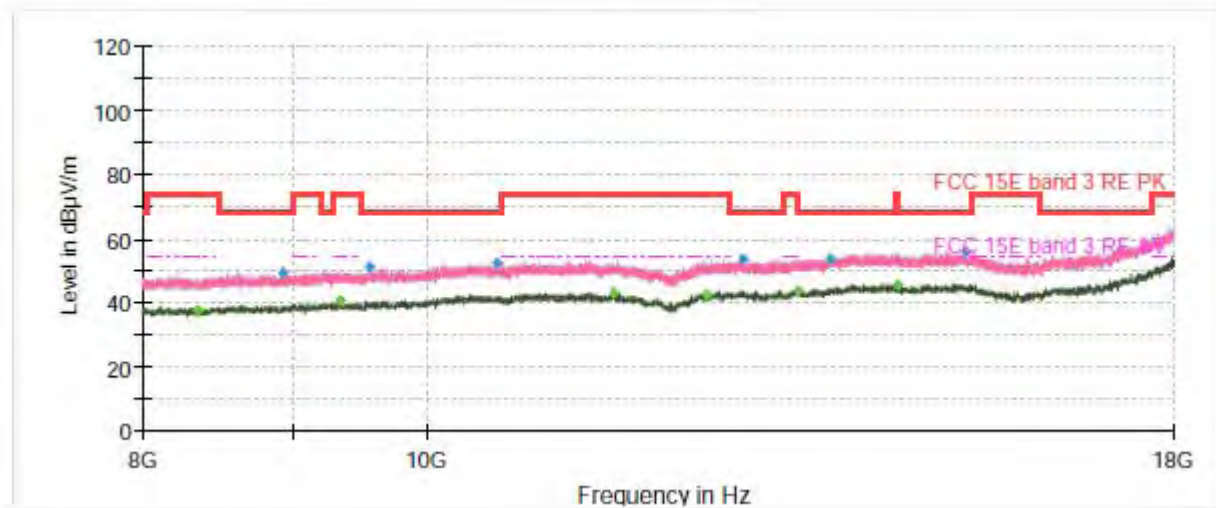

Radiates Emission from 8GHz to 18GHz



Frequency (MHz)	Peak (dBuV/m)	Average (dBuV/m)	Limit (dBuV/m)	Margin (dB)	Height (cm)	Polarization	Azimuth (deg)	Correct Factor (dB)
1285.366667	48.30	---	68.20	19.90	100.0	V	2.0	-8
1403.433333	---	39.48	54.00	14.52	200.0	V	350.0	-7
1695.800000	---	39.63	54.00	14.37	200.0	V	274.0	-6
1877.100000	50.45	---	68.20	17.75	100.0	V	224.0	-5
2682.100000	52.25	---	68.20	15.95	200.0	H	0.0	-3
2763.066667	---	42.44	54.00	11.56	100.0	H	9.0	-4
3456.766667	52.58	---	68.20	15.62	100.0	H	359.0	-3
3985.033333	---	43.43	54.00	10.57	100.0	V	58.0	-1
5208.166667	56.07	---	68.20	12.13	100.0	H	78.0	2
5429.133333	---	45.59	54.00	8.41	100.0	H	91.0	3
7745.900000	---	48.85	54.00	5.15	200.0	V	350.0	7
7916.933333	59.32	---	68.20	8.88	200.0	H	24.0	7

Remark: 1. Correction Factor = Antenna factor+ Insertion loss (cable loss + amplifier gain)



802.11ac (VHT80) CH42

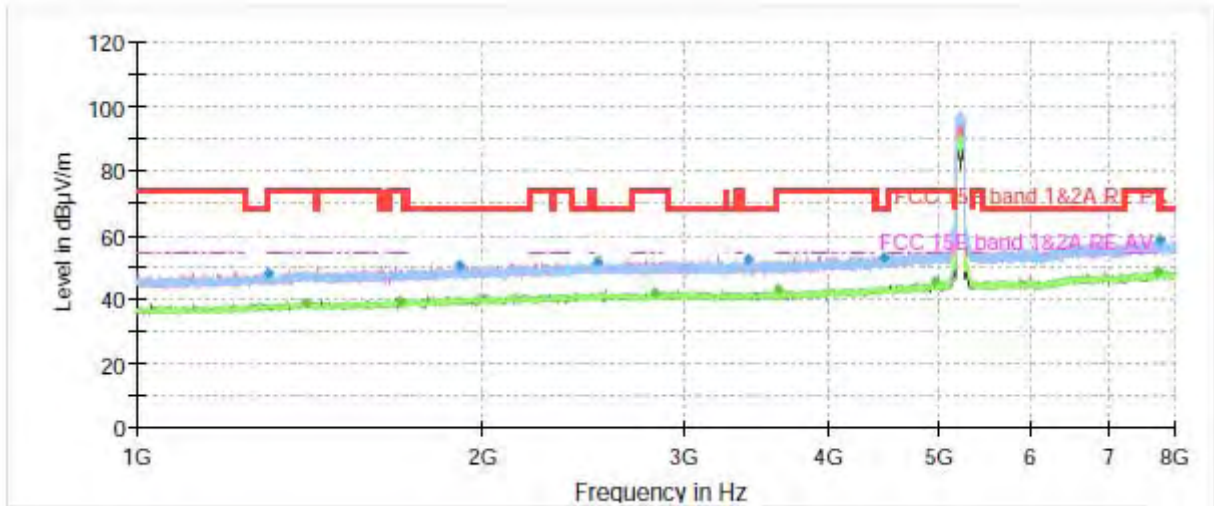

Note: The signal beyond the limit is carrier.
Radiates Emission from 1GHz to 8GHz

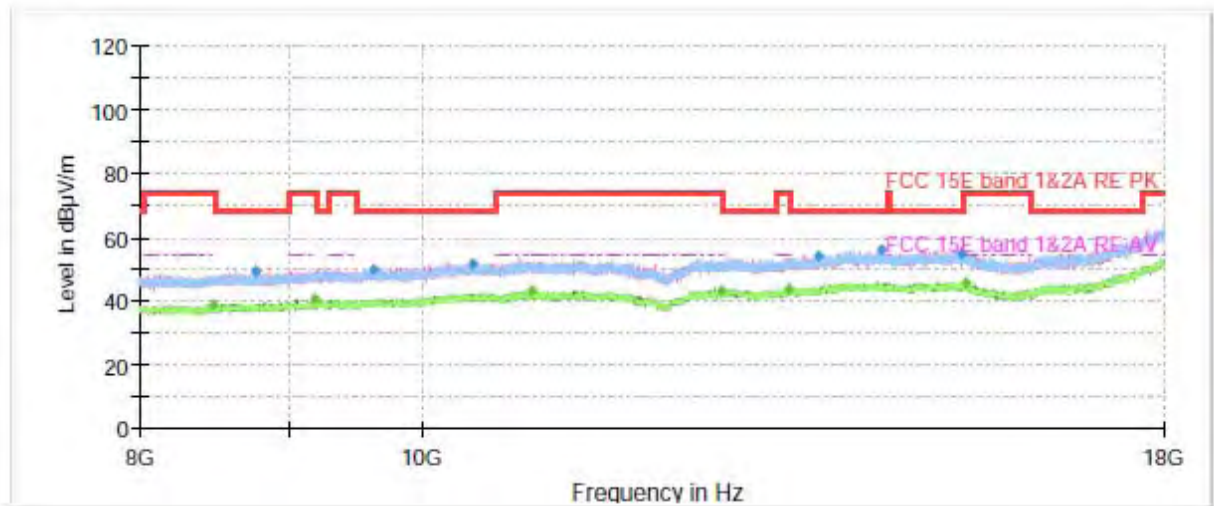

Radiates Emission from 8GHz to 18GHz



Frequency (MHz)	Peak (dBuV/m)	Average (dBuV/m)	Limit (dBuV/m)	Margin (dB)	Height (cm)	Polarization	Azimuth (deg)	Correct Factor (dB)
1299.366667	48.08	---	68.20	20.12	100.0	H	164.0	-8
1407.166667	---	39.06	54.00	14.94	200.0	H	48.0	-7
1694.866667	---	39.59	54.00	14.41	200.0	V	354.0	-6
1906.966667	50.60	---	68.20	17.60	200.0	H	48.0	-5
2519.466667	51.68	---	68.20	16.52	200.0	H	236.0	-4
2823.733333	---	41.92	54.00	12.08	200.0	V	139.0	-3
3402.866667	52.51	---	68.20	15.69	100.0	V	1.0	-3
3604.933333	---	43.00	54.00	11.00	100.0	H	109.0	-3
4472.000000	52.82	---	68.20	15.38	200.0	V	344.0	0
4938.433333	---	45.43	54.00	8.57	100.0	V	222.0	2
7721.633333	---	48.59	54.00	5.41	200.0	V	324.0	7
7776.000000	58.72	---	68.20	9.48	200.0	H	168.0	7

Remark: 1. Correction Factor = Antenna factor+ Insertion loss (cable loss + amplifier gain)



802.11ac (VHT80) CH58

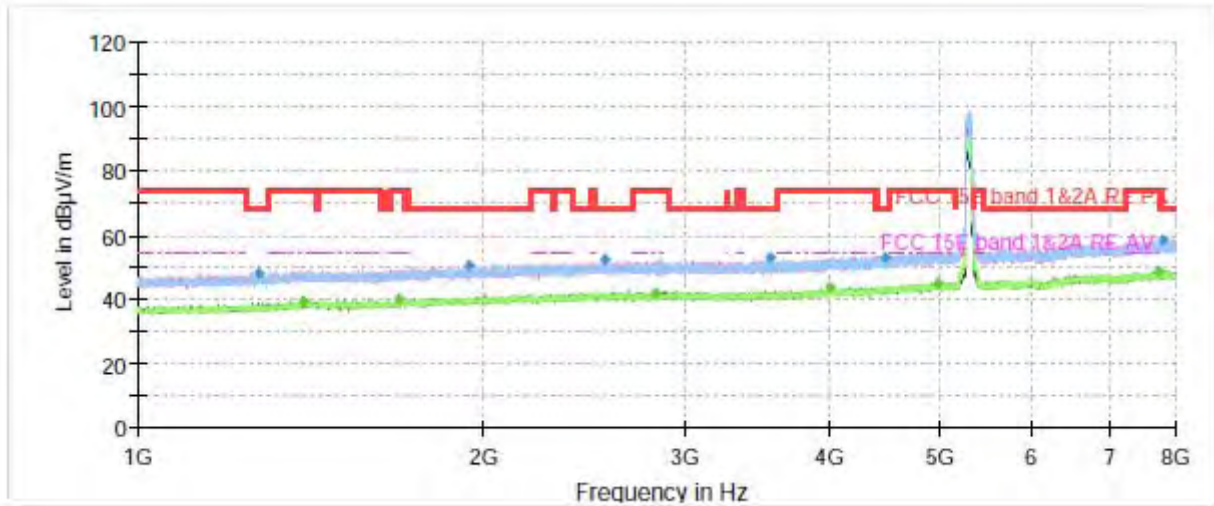

Note: The signal beyond the limit is carrier.
Radiates Emission from 1GHz to 8GHz

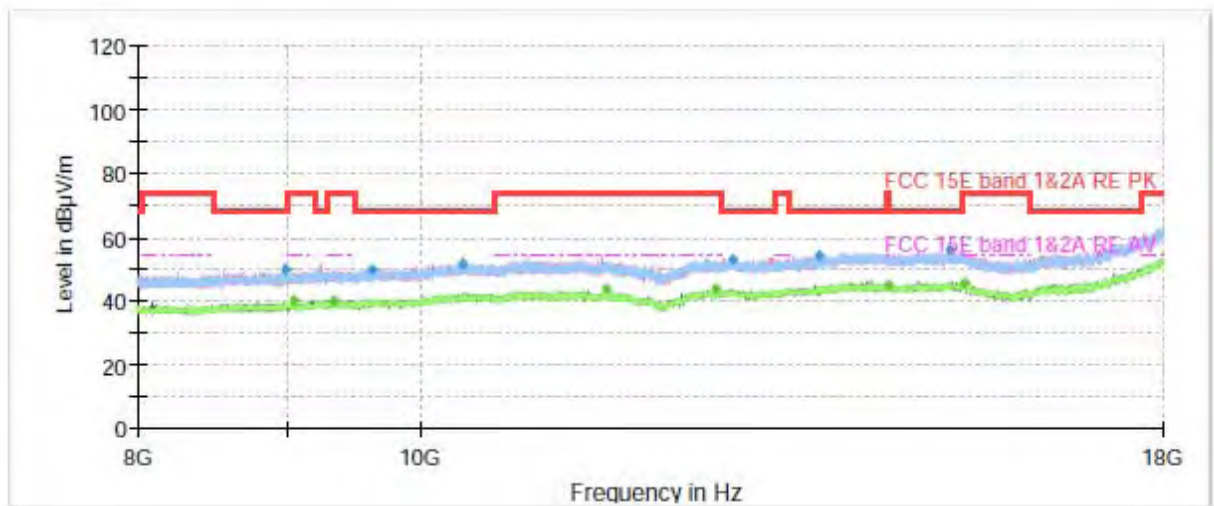

Radiates Emission from 8GHz to 18GHz



Frequency (MHz)	Peak (dBuV/m)	Average (dBuV/m)	Limit (dBuV/m)	Margin (dB)	Height (cm)	Polarization	Azimuth (deg)	Correct Factor (dB)
1273.000000	48.29	---	68.20	19.91	100.0	H	121.0	-8
1391.766667	---	39.43	54.00	14.57	200.0	V	354.0	-7
1685.766667	---	39.91	54.00	14.09	100.0	V	8.0	-6
1941.266667	50.16	---	68.20	18.04	200.0	V	67.0	-5
2553.066667	52.48	---	68.20	15.72	200.0	V	215.0	-4
2823.033333	---	41.99	54.00	12.01	200.0	H	4.0	-3
3551.500000	52.83	---	68.20	15.37	200.0	H	116.0	-3
3994.833333	---	43.40	54.00	10.60	200.0	H	169.0	-1
4467.566667	53.11	---	68.20	15.09	100.0	V	245.0	0
4960.833333	---	45.04	54.00	8.96	100.0	V	163.0	2
7730.966667	---	48.45	54.00	5.55	200.0	V	189.0	7
7784.166667	58.76	---	68.20	9.44	200.0	V	256.0	7

Remark: 1. Correction Factor = Antenna factor+ Insertion loss (cable loss + amplifier gain)

802.11ac (VHT80) CH106

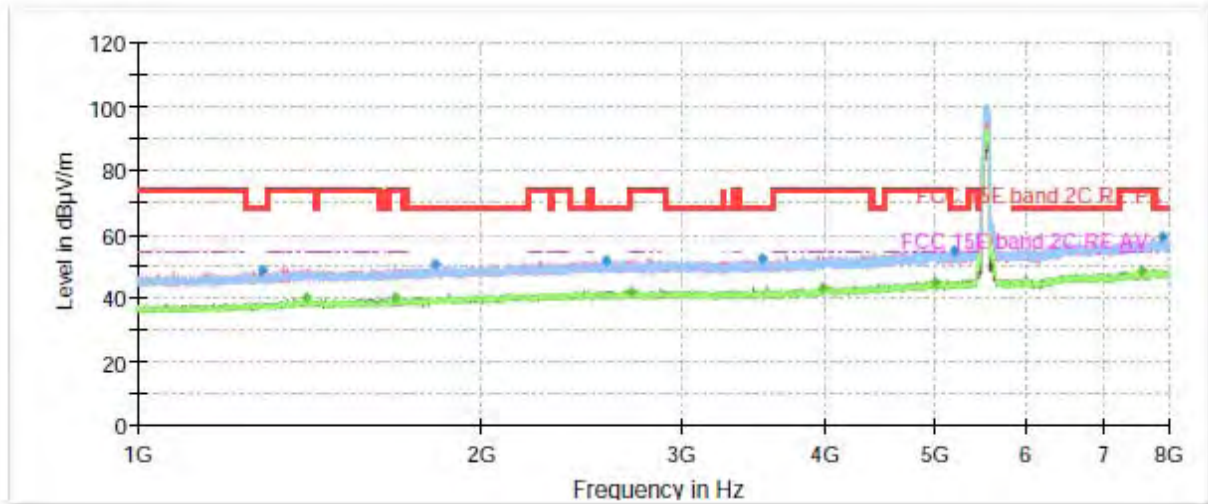

Note: The signal beyond the limit is carrier.
Radiates Emission from 1GHz to 8GHz

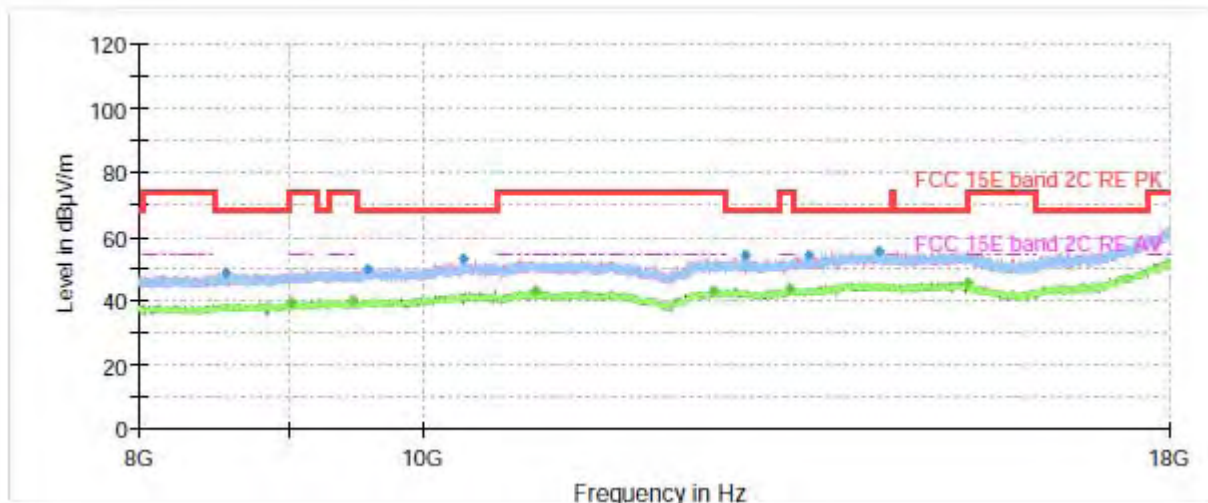

Radiates Emission from 8GHz to 18GHz



Frequency (MHz)	Peak (dBuV/m)	Average (dBuV/m)	Limit (dBuV/m)	Margin (dB)	Height (cm)	Polarization	Azimuth (deg)	Correct Factor (dB)
1286.766667	48.53	---	68.20	19.67	200.0	H	359.0	-8
1403.200000	---	39.85	54.00	14.15	200.0	V	325.0	-7
1678.533333	---	39.84	54.00	14.16	100.0	H	356.0	-6
1821.566667	50.75	---	68.20	17.45	200.0	V	325.0	-6
2568.000000	51.92	---	68.20	16.28	200.0	V	0.0	-4
2708.933333	---	41.86	54.00	12.14	200.0	V	0.0	-4
3525.133333	52.23	---	68.20	15.97	200.0	H	24.0	-3
3986.200000	---	43.24	54.00	10.76	100.0	V	350.0	-1
4998.166667	---	45.21	54.00	8.79	100.0	V	139.0	2
5181.800000	54.97	---	68.20	13.23	100.0	V	100.0	2
7572.066667	---	48.60	54.00	5.40	100.0	V	33.0	7
7882.166667	58.98	---	68.20	9.22	200.0	V	219.0	7

Remark: 1. Correction Factor = Antenna factor+ Insertion loss (cable loss + amplifier gain)

802.11ac (VHT80) CH122

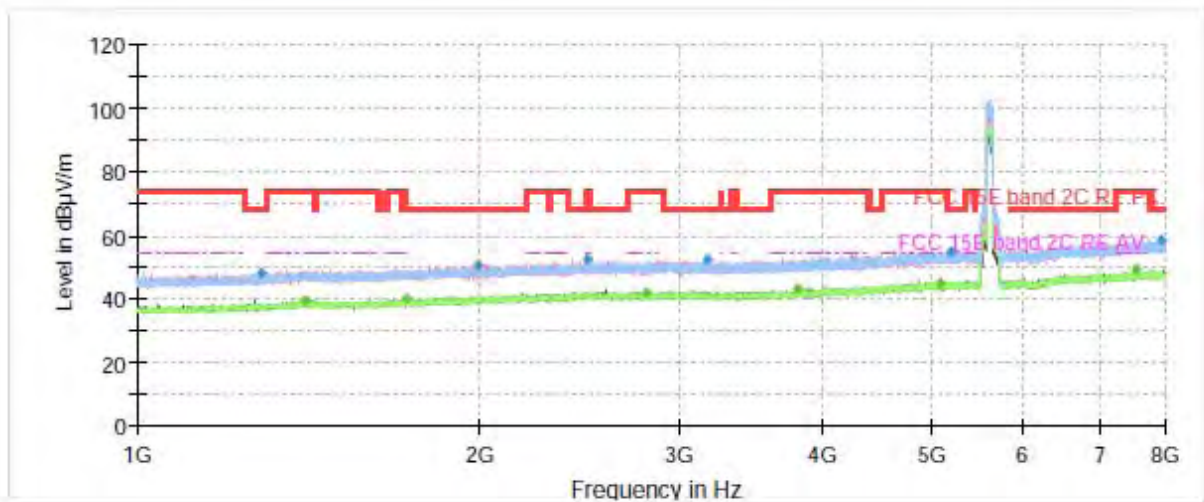

Note: The signal beyond the limit is carrier.
Radiates Emission from 1GHz to 8GHz

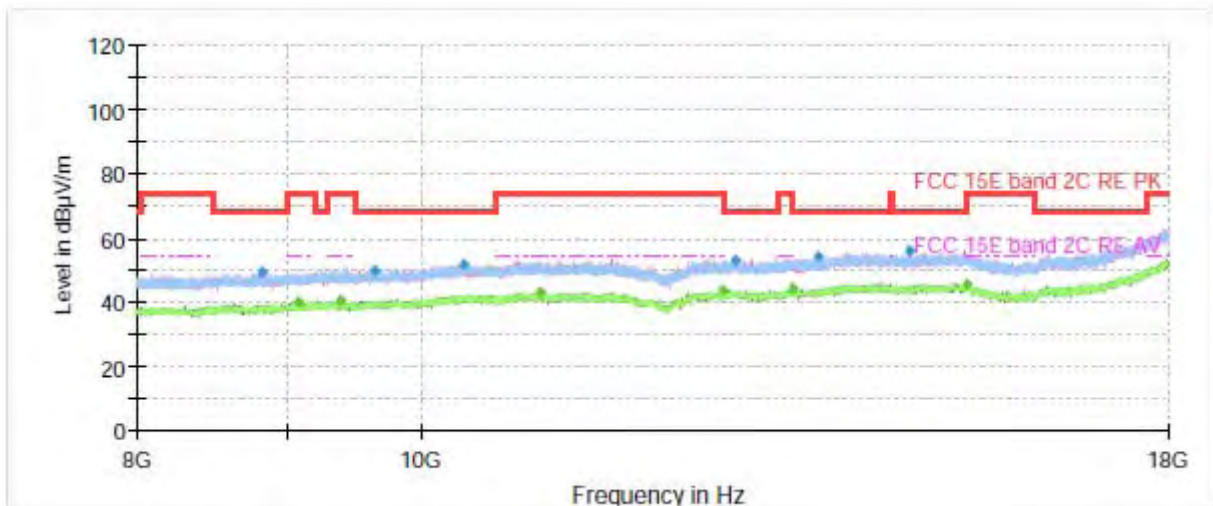

Radiates Emission from 8GHz to 18GHz



Frequency (MHz)	Peak (dBuV/m)	Average (dBuV/m)	Limit (dBuV/m)	Margin (dB)	Height (cm)	Polarization	Azimuth (deg)	Correct Factor (dB)
1287.000000	48.29	---	68.20	19.91	100.0	H	189.0	-8
1404.833333	---	39.27	54.00	14.73	200.0	V	190.0	-7
1720.766667	---	39.74	54.00	14.26	100.0	H	0.0	-6
1987.700000	50.40	---	68.20	17.80	100.0	V	16.0	-5
2482.366667	52.17	---	68.20	16.03	200.0	H	279.0	-4
2801.800000	---	42.07	54.00	11.93	100.0	V	210.0	-3
3167.666667	52.27	---	68.20	15.93	200.0	H	211.0	-3
3805.833333	---	43.16	54.00	10.84	200.0	V	163.0	-2
5085.900000	---	45.11	54.00	8.89	100.0	V	144.0	2
5175.033333	54.85	---	68.20	13.35	100.0	V	16.0	2
7552.933333	---	49.28	54.00	4.72	200.0	V	176.0	7
7919.266667	58.42	---	68.20	9.78	100.0	H	149.0	7

Remark: 1. Correction Factor = Antenna factor+ Insertion loss (cable loss + amplifier gain)

802.11ac (VHT80) CH138

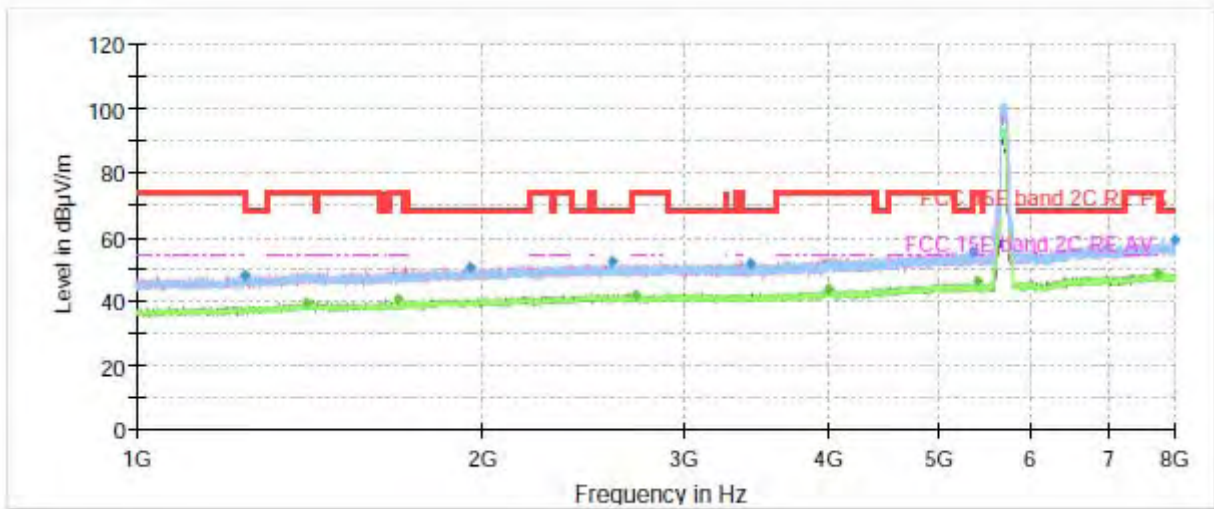

Note: The signal beyond the limit is carrier.
Radiates Emission from 1GHz to 8GHz

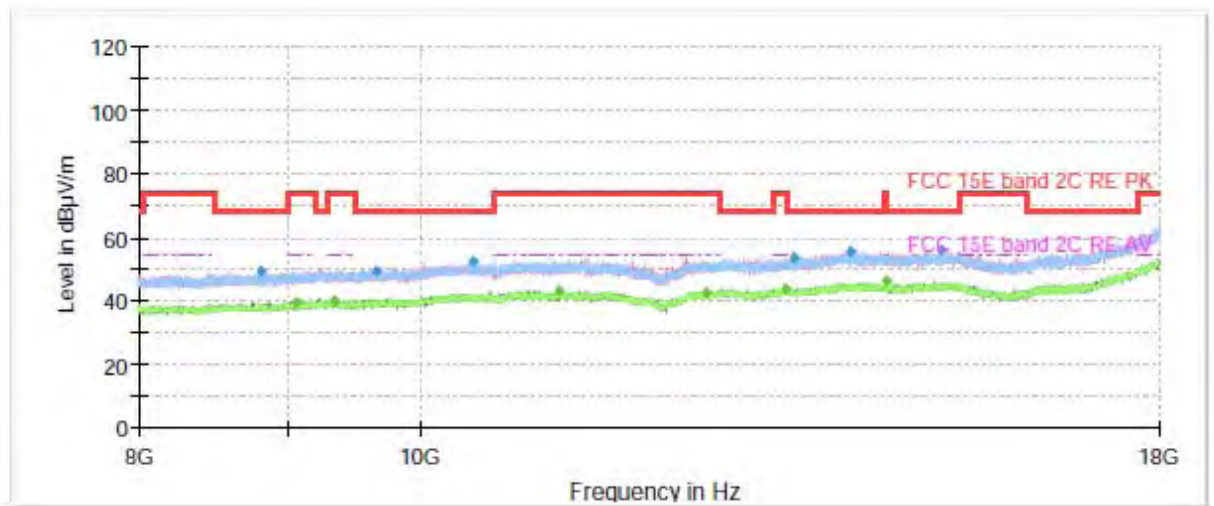

Radiates Emission from 8GHz to 18GHz



Frequency (MHz)	Peak (dBuV/m)	Average (dBuV/m)	Limit (dBuV/m)	Margin (dB)	Height (cm)	Polarization	Azimuth (deg)	Correct Factor (dB)
1242.900000	47.95	---	68.20	20.25	100.0	V	2.0	-8
1403.433333	---	39.46	54.00	14.54	100.0	H	322.0	-7
1689.966667	---	40.32	54.00	13.68	200.0	V	312.0	-6
1948.733333	50.70	---	68.20	17.50	100.0	H	354.0	-5
2596.933333	52.29	---	68.20	15.91	200.0	V	326.0	-4
2715.233333	---	41.84	54.00	12.16	200.0	V	189.0	-4
3424.100000	51.93	---	68.20	16.27	200.0	H	8.0	-3
3998.100000	---	43.49	54.00	10.51	100.0	V	143.0	-1
5343.966667	55.23	---	68.20	12.97	200.0	V	345.0	3
5375.466667	---	45.91	54.00	8.09	200.0	V	0.0	3
7747.533333	---	48.59	54.00	5.41	100.0	H	343.0	7
7983.433333	58.90	---	68.20	9.30	200.0	V	257.0	8

Remark: 1. Correction Factor = Antenna factor+ Insertion loss (cable loss + amplifier gain)

802.11ac (VHT80) CH155

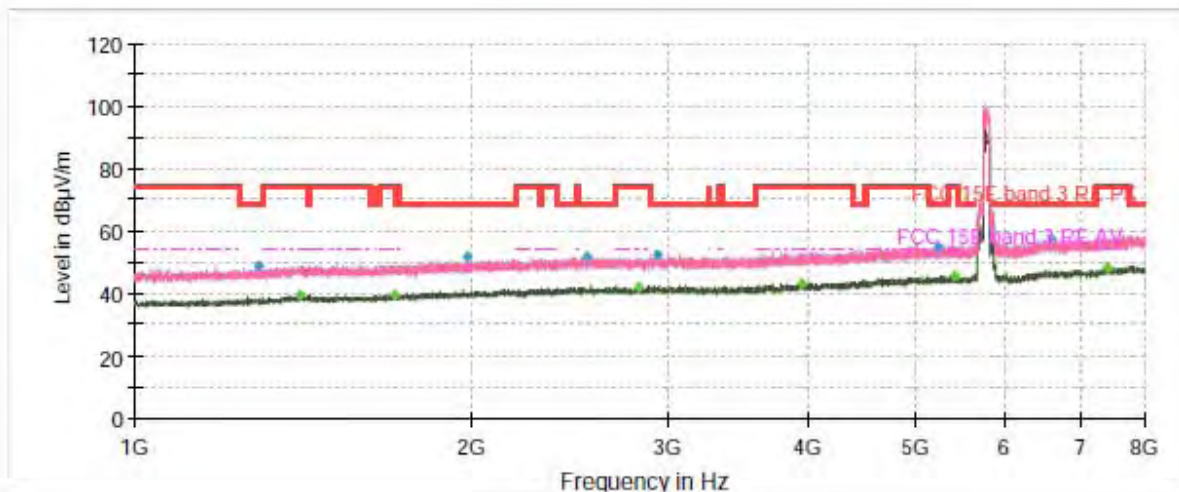

Note: The signal beyond the limit is carrier.
Radiates Emission from 1GHz to 8GHz

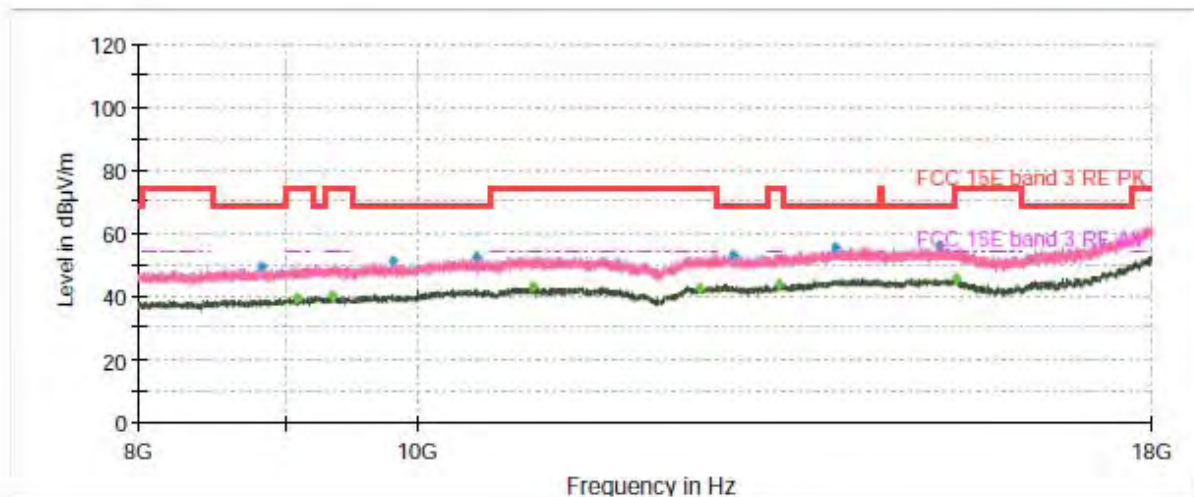

Radiates Emission from 8GHz to 18GHz



Frequency (MHz)	Peak (dBuV/m)	Average (dBuV/m)	Limit (dBuV/m)	Margin (dB)	Height (cm)	Polarization	Azimuth (deg)	Correct Factor (dB)
1290.500000	48.41	---	68.20	19.79	100.0	H	336.0	-8
1402.266667	---	39.47	54.00	14.53	100.0	V	181.0	-7
1707.233333	---	39.66	54.00	14.34	200.0	H	134.0	-6
1983.266667	51.48	---	68.20	16.72	200.0	V	76.0	-5
2542.333333	51.85	---	68.20	16.35	100.0	H	0.0	-4
2826.533333	---	41.88	54.00	12.12	100.0	V	359.0	-3
2932.466667	52.03	---	68.20	16.17	200.0	H	335.0	-3
3957.500000	---	43.26	54.00	10.74	200.0	V	128.0	-1
5231.266667	54.59	---	68.20	13.61	200.0	V	156.0	2
5410.700000	---	45.49	54.00	8.51	100.0	V	9.0	3
6614.000000	57.47	---	68.20	10.73	200.0	V	115.0	6
7396.600000	---	48.18	54.00	5.82	200.0	V	293.0	7

Remark: 1. Correction Factor = Antenna factor+ Insertion loss (cable loss + amplifier gain)



During the test, the Radiates Emission from 18GHz to 40GHz was performed in all modes with all channels, 802.11n (HT20), Channel 48 are selected as the worst condition. The test data of the worst-case condition was recorded in this report.

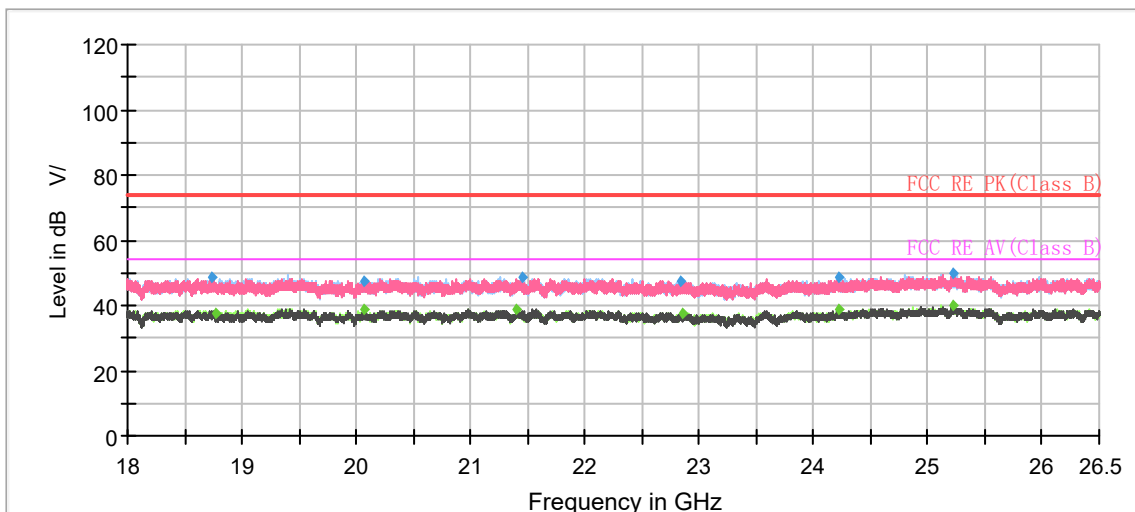

Radiates Emission from 18GHz to 26.5GHz

Frequency (MHz)	Peak (dBuV/m)	Average (dBuV/m)	Limit (dBuV/m)	Margin (dB)	Height (cm)	Polarization	Azimuth (deg)	Correct Factor (dB)
18742.333333	48.40	---	74.00	25.60	100.0	H	314.0	-2
18766.700000	---	37.66	54.00	16.34	100.0	H	306.0	-2
20063.800000	---	38.67	54.00	15.33	200.0	H	165.0	-1
20070.883333	47.63	---	74.00	26.37	200.0	H	242.0	-1
21408.216667	---	39.07	54.00	14.93	200.0	H	90.0	0
21453.266667	48.58	---	74.00	25.42	200.0	H	127.0	0
22835.366667	47.40	---	74.00	26.60	100.0	H	321.0	2
22846.133333	---	37.76	54.00	16.24	200.0	V	108.0	2
24218.883333	48.44	---	74.00	25.56	100.0	V	0.0	2
24220.866667	---	38.74	54.00	15.26	100.0	H	260.0	2
25219.900000	50.06	---	74.00	23.94	200.0	V	194.0	3
25227.833333	---	39.88	54.00	14.12	200.0	H	44.0	3

Remark: 1. Correction Factor = Antenna factor+ Insertion loss (cable loss + amplifier gain)

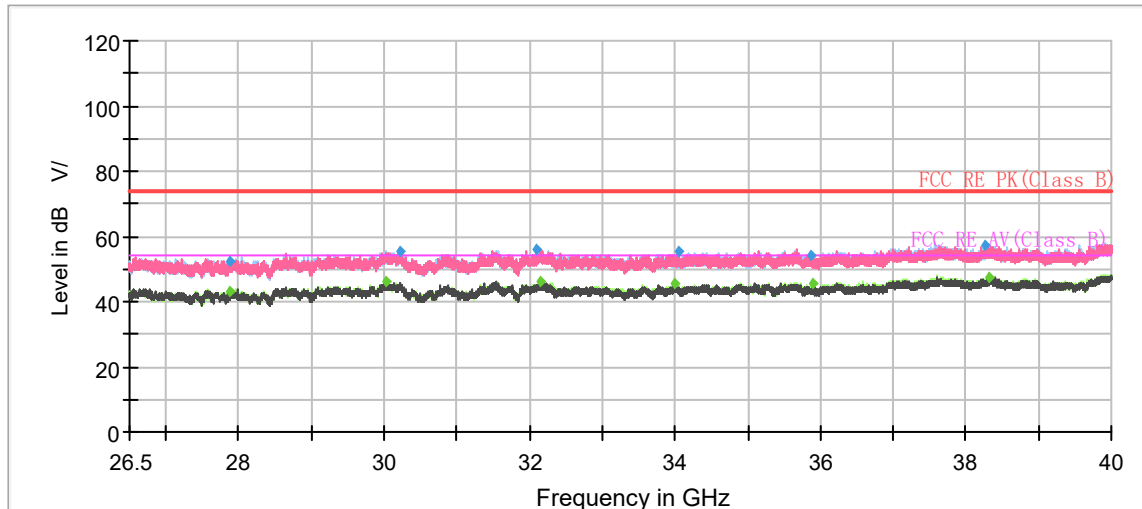

Radiates Emission from 26.5GHz to 40GHz

Frequency (MHz)	Peak (dBuV/m)	Average (dBuV/m)	Limit (dBuV/m)	Margin (dB)	Height (cm)	Polarization	Azimuth (deg)	Correct Factor (dB)
27877.450000	---	42.77	54.00	11.23	200.0	H	282.0	6
27886.000000	52.09	---	74.00	21.91	200.0	H	11.0	6
30014.950000	---	45.91	54.00	8.09	200.0	H	219.0	7
30217.000000	55.38	---	74.00	18.62	200.0	H	282.0	7
32106.550000	55.98	---	74.00	18.02	100.0	H	218.0	8
32135.800000	---	45.92	54.00	8.08	200.0	V	38.0	8
34003.750000	---	45.67	54.00	8.33	200.0	H	204.0	8
34037.050000	55.10	---	74.00	18.90	100.0	V	356.0	8
35869.900000	54.36	---	74.00	19.64	200.0	V	245.0	8
35900.500000	---	45.38	54.00	8.62	200.0	H	11.0	8
38258.950000	57.35	---	74.00	16.65	200.0	H	156.0	11
38324.200000	---	47.64	54.00	6.36	200.0	V	322.0	11

Remark: 1. Correction Factor = Antenna factor+ Insertion loss (cable loss + amplifier gain)

5.6. Conducted Emission

Ambient condition

Temperature	Relative humidity	Pressure
23°C ~25°C	45%~50%	101.5kPa

Methods of Measurement

The EUT IS placed on a non-metallic table of 80cm height above the horizontal metal reference ground plane. During the test, the EUT was operating in its typical mode. The test method is according to ANSI C63.10. Connect the AC power line of the EUT to the LISN Use EMI receiver to detect the average and Quasi-peak value. RBW is set to 9kHz, VBW is set to 30kHz The measurement result should include both L line and N line.

The test is in transmitting mode.

Test Setup

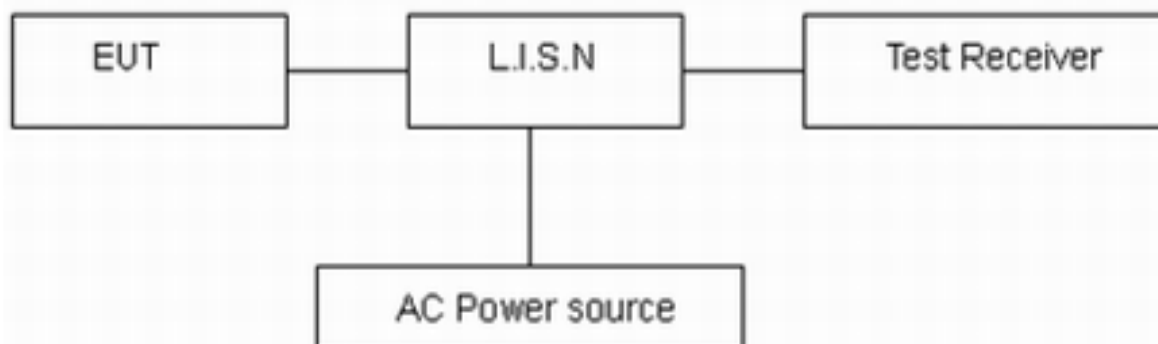

Note: AC Power source is used to change the voltage 110V/60Hz.

Limits

Frequency (MHz)	Conducted Limits(dBμV)	
	Quasi-peak	Average
0.15 - 0.5	66 to 56 *	56 to 46 *
0.5 - 5	56	46
5 - 30	60	50

*: Decreases with the logarithm of the frequency.

Measurement Uncertainty

The assessed measurement uncertainty to ensure 95% confidence level for the normal distribution is with the coverage factor $k = 1.96$, $U = 2.69$ dB.

Test Results:

Following plots, Blue trace uses the peak detection and Green trace uses the average detection. During the test, the Conducted Emission was performed in all modes with all channels, 802.11n (HT20), Channel 48 are selected as the worst condition. The test data of the worst-case condition was recorded in this report.

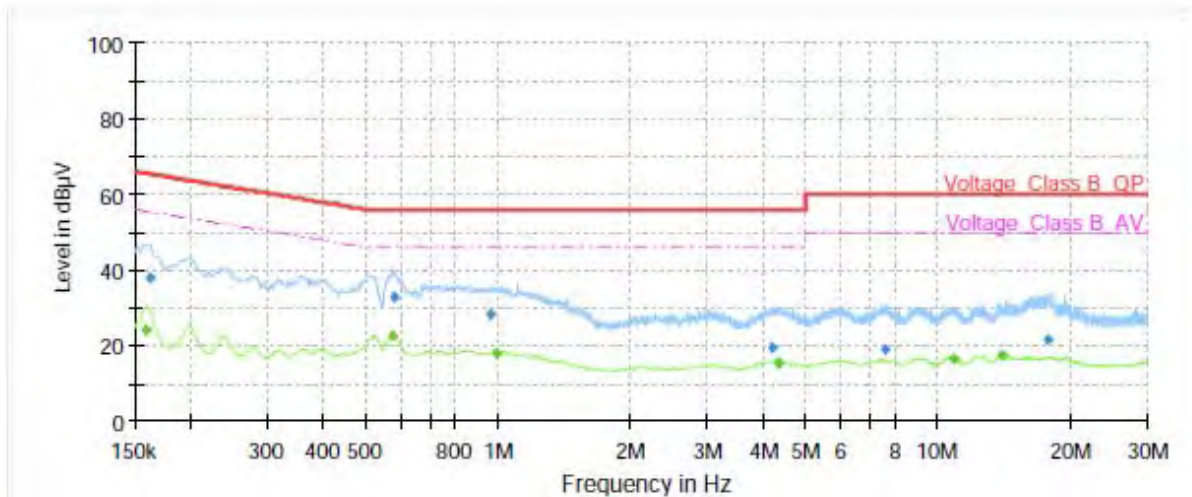

Frequency (MHz)	QuasiPeak (dBµV)	Average (dBµV)	Limit (dBµV)	Margin (dB)	Meas. Time (ms)	Bandwidth (kHz)	Line	Filter	Corr. (dB)
0.16	---	24.25	55.52	31.27	70.0	9.000	L1	ON	21
0.16	37.76	---	65.40	27.64	70.0	9.000	L1	ON	21
0.58	---	22.50	46.00	23.50	70.0	9.000	L1	ON	20
0.58	32.99	---	56.00	23.01	70.0	9.000	L1	ON	20
0.96	28.24	---	56.00	27.76	70.0	9.000	L1	ON	20
1.00	---	17.92	46.00	28.08	70.0	9.000	L1	ON	20
4.18	19.45	---	56.00	36.55	70.0	9.000	L1	ON	19
4.34	---	15.38	46.00	30.62	70.0	9.000	L1	ON	19
7.58	19.22	---	60.00	40.78	70.0	9.000	L1	ON	20
10.86	---	16.63	50.00	33.37	70.0	9.000	L1	ON	20
14.03	---	17.36	50.00	32.64	70.0	9.000	L1	ON	20
17.83	21.39	---	60.00	38.61	70.0	9.000	L1	ON	20

Remark: Correct factor=cable loss + LISN factor

L line Conducted Emission from 150 KHz to 30 MHz

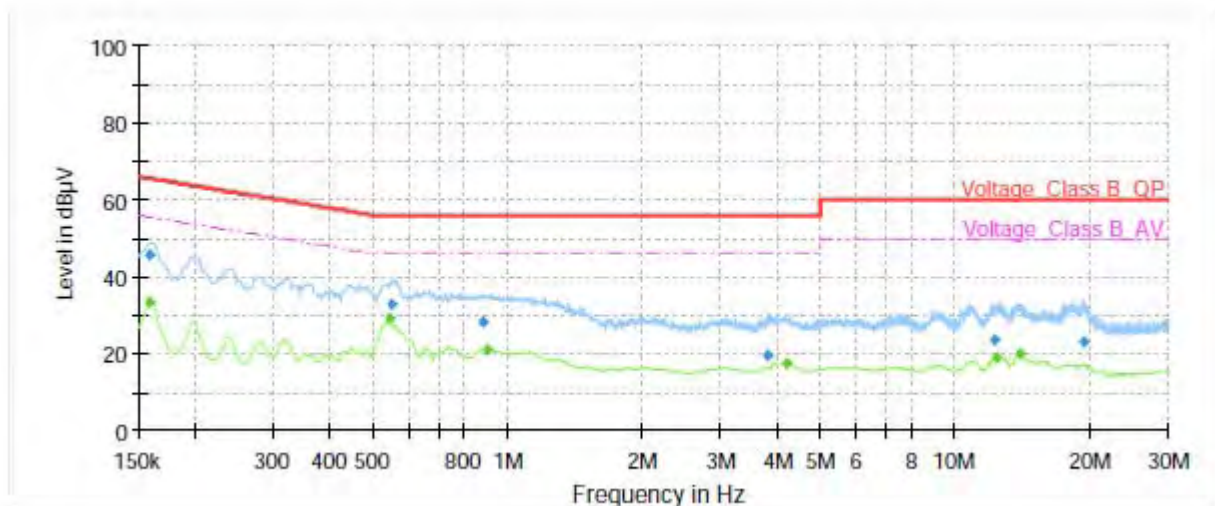

Frequency (MHz)	QuasiPeak (dBµV)	Average (dBµV)	Limit (dBµV)	Margin (dB)	Meas. Time (ms)	Bandwidth (kHz)	Line	Filter	Corr. (dB)
0.16	---	33.56	55.52	21.96	70.0	9.000	N	ON	21
0.16	45.44	---	65.52	20.08	70.0	9.000	N	ON	21
0.55	---	29.17	46.00	16.83	70.0	9.000	N	ON	20
0.55	32.72	---	56.00	23.28	70.0	9.000	N	ON	20
0.88	28.37	---	56.00	27.63	70.0	9.000	N	ON	20
0.90	---	21.09	46.00	24.91	70.0	9.000	N	ON	20
3.83	19.23	---	56.00	36.77	70.0	9.000	N	ON	19
4.19	---	17.35	46.00	28.65	70.0	9.000	N	ON	19
12.29	23.82	---	60.00	36.18	70.0	9.000	N	ON	20
12.39	---	19.03	50.00	30.97	70.0	9.000	N	ON	20
13.93	---	20.07	50.00	29.93	70.0	9.000	N	ON	20
19.41	23.11	---	60.00	36.89	70.0	9.000	N	ON	20

Remark: Correct factor=cable loss + LISN factor

N line Conducted Emission from 150 KHz to 30 MHz



6. Main Test Instruments

Name	Manufacturer	Type	Serial Number	Calibration Date	Expiration Date
EMI Test Receiver	R&S	ESC17	100936	2021-12-12	2022-12-11
Signal Analyzer	R&S	FSV40	100815	2021-05-15	2022-05-14
TRILOG Broadband Antenna	SCHWARZBECK	9163	1023	2021-06-07	2024-06-06
Horn Antenna	R&S	HF907	102723	2021-07-26	2024-07-25
Horn Antenna	ETS-Lindgren	3160-09	00102643	2020-10-10	2023-10-09
Horn Antenna	STEATITE	QSH-SL-26-40-K-15	16779	2019-12-24	2022-12-23
Software	R&S	EMC32	9.26.01	/	/
Artificial main network	R&S	ENV216	101171	2020-12-13	2022-12-12
EMI Test Receiver	R&S	ESR	101667	2021-05-15	2022-05-14
Software	R&S	EMC32	10.35.10	/	/
Spectrum Analyzer	KEYSIGHT	N9020A	MY54420163	2021-12-12	2022-12-11
Power probe	R&S	NRP18S	101954	2021-05-15	2022-05-14
Climate Chamber	ESPEC	SU-242	93000506	2021-12-12	2022-12-11

*****END OF REPORT *****



ANNEX A: The EUT Appearance

The EUT Appearance are submitted separately.



ANNEX B: Test Setup Photos

The Test Setup Photos are submitted separately.