

FCC RF Test Report

APPLICANT : Xiaomi Communications Co., Ltd.
EQUIPMENT : Mobile Phone
BRAND NAME : Redmi
MODEL NAME : 22101316UG
FCC ID : 2AFZZ1316UG
STANDARD : 47 CFR Part 2, Part 27 Subpart Q
CLASSIFICATION : PCS Licensed Transmitter Held to Ear (PCE)
TEST DATE(S) : Sep. 15, 2022 ~ Sep. 26, 2022

We, Sporton International Inc. (Kunshan), would like to declare that the tested sample has been evaluated in accordance with the procedures given in ANSI C63.26-2015 and shown compliance with the applicable technical standards.

This report contains data that were produced under subcontract by Sporton International Inc (Shenzhen).

The test results in this report apply exclusively to the tested model / sample. Without written approval of Sporton International Inc. (Kunshan), the test report shall not be reproduced except in full.

Jason Jia

Approved by: Jason Jia



Sporton International Inc. (Kunshan)

**No. 1098, Pengxi North Road, Kunshan Economic Development Zone Jiangsu Province 215300
People's Republic of China**



TABLE OF CONTENTS

REVISION HISTORY..... 3
SUMMARY OF TEST RESULT 4
1 GENERAL DESCRIPTION 5
1.1 Applicant 5
1.2 Manufacturer 5
1.3 Product Feature of Equipment Under Test 5
1.4 Product Specification of Equipment Under Test 5
1.5 Modification of EUT 6
1.6 Maximum EIRP Power and Emission Designator 6
1.7 Testing Site 7
1.8 Test Software 8
1.9 Applied Standards 8
2 TEST CONFIGURATION OF EQUIPMENT UNDER TEST 9
2.1 Test Mode 9
2.2 Connection Diagram of Test System 10
2.3 Support Unit used in test configuration and system 10
2.4 Measurement Results Explanation Example 10
2.5 Frequency List of Low/Middle/High Channels 11
3 CONDUCTED TEST ITEMS 13
3.1 Measuring Instruments 13
3.2 Test Setup 13
3.3 Test Result of Conducted Test 13
3.4 Conducted Output Power Measurement 14
3.5 Peak-to-Average Ratio 15
3.6 EIRP 16
3.7 Occupied Bandwidth 17
3.8 Conducted Band Edge Measurement 18
3.9 Conducted Spurious Emission Measurement 19
3.10 Frequency Stability Measurement 20
4 RADIATED TEST ITEMS 21
4.1 Measuring Instruments 21
4.2 Test Setup 21
4.3 Test Result of Radiated Test 22
4.4 Radiated Spurious Emission Measurement 23
5 LIST OF MEASURING EQUIPMENT 24
6 UNCERTAINTY OF EVALUATION 25
APPENDIX A. TEST RESULTS OF CONDUCTED TEST
APPENDIX B. TEST RESULTS OF RADIATED TEST
APPENDIX C. TEST SETUP PHOTOGRAPHS

SUMMARY OF TEST RESULT

Report Section	FCC Rule	Description	Limit	Result	Remark
3.4	§2.1046	Conducted Output Power	—	Report Only	-
3.5	§27.50 (k)(4)	Peak-to-Average Ratio	<13dB	PASS	
3.6	§27.50 (k)(3)	EIRP	EIRP < 1W (30dBm)	PASS	-
3.7	§2.1049	Occupied Bandwidth	—	Report Only	-
3.8	§2.1051 §27.53 (n)(2)	Conducted Band Edge Measurement	-13dBm/MHz	PASS	-
3.9	§2.1051 §27.53 (n)(2)	Conducted Spurious Emission	-13dBm/MHz	PASS	-
3.10	§2.1055 §27.54	Frequency Stability Temperature & Voltage	Within the band	PASS	-
4.4	§2.1053 §27.53 (n)(2)	Radiated Spurious Emission	-13dBm/MHz	PASS	Under limit 34.70 dB at 13806.00 MHz

Declaration of Conformity:

The test results with all measurement uncertainty excluded are presented in accordance with the regulation limits or requirements declared by manufacturers.

Comments and Explanations:

The declared of product specification for EUT presented in the report are provided by the manufacturer, and the manufacturer takes all the responsibilities for the accuracy of product specification.

1 General Description

1.1 Applicant

Xiaomi Communications Co., Ltd.

#019, 9th Floor, Building 6, 33 Xi'erqi Middle Road, Haidian District, Beijing, China, 100085

1.2 Manufacturer

Xiaomi Communications Co., Ltd.

#019, 9th Floor, Building 6, 33 Xi'erqi Middle Road, Haidian District, Beijing, China, 100085

1.3 Product Feature of Equipment Under Test

Product Feature	
Equipment	Mobile Phone
Brand Name	Redmi
Model Name	22101316UG
FCC ID	2AFZZ1316UG
IMEI Code	Conducted : 868725060027474/868725060027482 868725060028951/868725060028969 Radiation : 868725060043950/868725060044578
HW Version	P2
SW Version	MIUI14
EUT Stage	Identical Prototype

1.4 Product Specification of Equipment Under Test

Product Feature	
Tx/Rx Frequency	5G NR n77: 3450 MHz ~ 3550 MHz 5G NR n78: 3450 MHz ~ 3550 MHz
Bandwidth	n77: 20 / 40 / 50 / 60 / 80 / 90 / 100MHz n78: 20 / 30 / 40 / 50 / 60 / 80 / 90 / 100MHz
SCS	30kHz
Antenna Gain	Ant. 2: 5G NR n77: 1.1 dBi 5G NR n78: 1.1 dBi Ant. 4: 5G NR n77: -3.6 dBi 5G NR n78: -3.6 dBi Ant. 5: 5G NR n77: -1.2 dBi 5G NR n78: -1.2 dBi Ant. 6:

	5G NR n77: -1.4 dBi 5G NR n78: -1.4 dBi
Type of Modulation	CP-OFDM: QPSK / 16QAM / 64QAM / 256QAM DFT-s-OFDM: PI/2 BPSK / QPSK / 16QAM / 64QAM / 256QAM

Remark:

1. The maximum EIRP is calculated from max output power and max antenna gain, only the maximum EIRP of ANT2 are shown in the report for 5G NR n77/n78.
2. 5G NR n78 supports SA and NSA mode, n77 supports SA mode only. The whole testing has assessed SA mode for n78 by referring to the higher conducted power for conducted test items.
3. 5G NR n77/n78 support HPUE mode.
4. The EN-DC mode combination could be referred to the product spec.

1.5 Modification of EUT

No modifications are made to the EUT during all test items.

1.6 Maximum EIRP Power and Emission Designator

5G NR n77 HPUE		PI/2 BPSK / QPSK		16QAM/64QAM/256QAM	
BW (MHz)	Frequency Range (MHz)	Maximum EIRP(W)	Emission Designator (99%OBW)	Maximum EIRP(W)	Emission Designator (99%OBW)
20	3460.02 ~ 3540.00	0.6823	18M1G7D	0.5521	18M2W7D
40	3470.01 ~ 3529.98	0.6531	37M8G7D	0.4977	37M9W7D
50	3475.02 ~ 3525.00	0.6823	47M5G7D	0.5248	47M5W7D
60	3480.00 ~ 3519.99	0.6730	57M9G7D	0.5117	57M8W7D
80	3490.02 ~ 3510.00	0.6166	77M5G7D	0.4864	77M4W7D
90	3495.00 ~ 3504.99	0.6039	87M5G7D	0.4667	87M5W7D
100	3500.01 ~ 3500.01	0.6839	97M4G7D	0.5521	97M3W7D



5G NR n78 HPUE		PI/2 BPSK / QPSK		16QAM/64QAM/256QAM	
BW (MHz)	Frequency Range (MHz)	Maximum EIRP(W)	Emission Designator (99%OBW)	Maximum EIRP(W)	Emission Designator (99%OBW)
20	3460.02 ~ 3540.00	0.6745	18M1G7D	0.4989	18M2W7D
30	3465.00 ~ 3534.99	0.6486	27M8G7D	0.4898	27M9W7D
40	3470.01 ~ 3529.98	0.6166	37M8G7D	0.4613	37M9W7D
50	3475.02 ~ 3525.00	0.6855	47M5G7D	0.5152	47M5W7D
60	3480.00 ~ 3519.99	0.6699	57M9G7D	0.5176	57M8W7D
80	3490.02 ~ 3510.00	0.6124	77M5G7D	0.4699	77M4W7D
90	3495.00 ~ 3504.99	0.5957	87M5G7D	0.4613	87M5W7D
100	3500.01 ~ 3500.01	0.7096	97M4G7D	0.5395	97M3W7D

Note:

- 5G NR Band n78 overlaps the entire frequency range of Band n77, and n78 power > n77 power, therefore the conducted test results of n78 provided in this report cover n77.
- All modulations have been tested, and only the worst test results of PSK & QAM are shown in the report.

1.7 Testing Site

Sporton International Inc. (Kunshan) is accredited to ISO/IEC 17025:2017 by American Association for Laboratory Accreditation with Certificate Number 5145.02.

Test Firm	Sporton International Inc. (Kunshan)		
Test Site Location	No. 1098, Pengxi North Road, Kunshan Economic Development Zone Jiangsu Province 215300 People's Republic of China TEL : +86-512-57900158 FAX : +86-512-57900958		
Test Site No.	Sporton Site No.	FCC Designation No.	FCC Test Firm Registration No.
	03CH04-KS	CN1257	314309

Sporton International Inc. (Shenzhen) is accredited to ISO/IEC 17025:2017 by American Association for Laboratory Accreditation with Certificate Number 5145.01.

Test Firm	Sporton International Inc. (Shenzhen)		
Test Site Location	1/F, 2/F, Bldg 5, Shiling Industrial Zone, Xinwei Village, Xili, Nanshan, Shenzhen, 518055 People's Republic of China TEL: +86-755-86379589 FAX: +86-755-86379595		
Test Site No.	Sporton Site No.	FCC Designation No.	FCC Test Firm Registration No.
	TH01-SZ	CN1256	421272

Note: Test data subcontracted: conducted test results in section 3 of this report

1.8 Test Software

Item	Site	Manufacturer	Name	Version
1.	03CH04-KS	AUDIX	E3	6.2009-8-24al

1.9 Applied Standards

According to the specifications of the manufacturer, the EUT must comply with the requirements of the following standards:

- ♦ 47 CFR Part 2, Part 27 Subpart Q
- ♦ ANSI C63.26-2015
- ♦ FCC KDB 971168 Power Meas License Digital Systems D01 v03r01
- ♦ FCC KDB 412172 D01 Determining ERP and EIRP v01r01
- ♦

Remark:



1. All test items were verified and recorded according to the standards and without any deviation during the test.
2. This EUT has also been tested and complied with the requirements of FCC Part 15, Subpart B, recorded in a separate test report.

2 Test Configuration of Equipment Under Test

2.1 Test Mode

Antenna port conducted and radiated test items listed below are performed according to KDB 971168 D01 Power Meas. License Digital Systems v03r01 with maximum output power.

For radiated measurement, pre-scanned in three orthogonal panels, X, Y, Z. The worst cases (Z plane) were recorded in this report.

Orthogonal Planes of EUT	X Plane	Y Plane	Z Plane
			

Test Items	5G NR	Bandwidth (MHz)								Modulation					RB #		Test Channel			
		20	30	40	50	60	80	90	100	PI/2 BPSK	QPSK	16QAM	64QAM	256 QAM	1	Full	L	M	H	
Max. Output Power	n77	v	-	v	v	v	v	v	v	v	v	v	v	v	v	v	v	v	v	
	n78	v	v	v	v	v	v	v	v	v	v	v	v	v	v	v	v	v	v	
Peak-to-Average Ratio	n78	v								v	v				v	v	v	v	v	
26dB and 99% Bandwidth	n78	v	v	v	v	v	v	v	v	v	v	v	v	v		v			v	
Conducted Band Edge	n78	v			v				v	v	v				v	v	v		v	
Conducted Spurious Emission	n78	v			v				v	v	v				v			v	v	v
Frequency Stability	n78	v									v					v			v	
E.R.P / E.I.R.P	n77	v	-	v	v	v	v	v	v	v	v	v	v	v	v	v	v	v	v	
	n78	v	v	v	v	v	v	v	v	v	v	v	v	v	v	v	v	v	v	
Radiated Spurious Emission	n78	Worst Case																	v	
Note	<ol style="list-style-type: none"> The mark "v" means that this configuration is chosen for testing The mark "-" means that this bandwidth is not supported. The device is investigated from 30MHz to 10 times of fundamental signal for radiated spurious emission test under different RB size/offset and modulations in exploratory test. Subsequently, only the worst case emissions are reported. Frequency Stability : Normal Voltage = 3.87V ; Low Voltage =3.60V. ; High Voltage =4.30V 																			

2.2 Connection Diagram of Test System

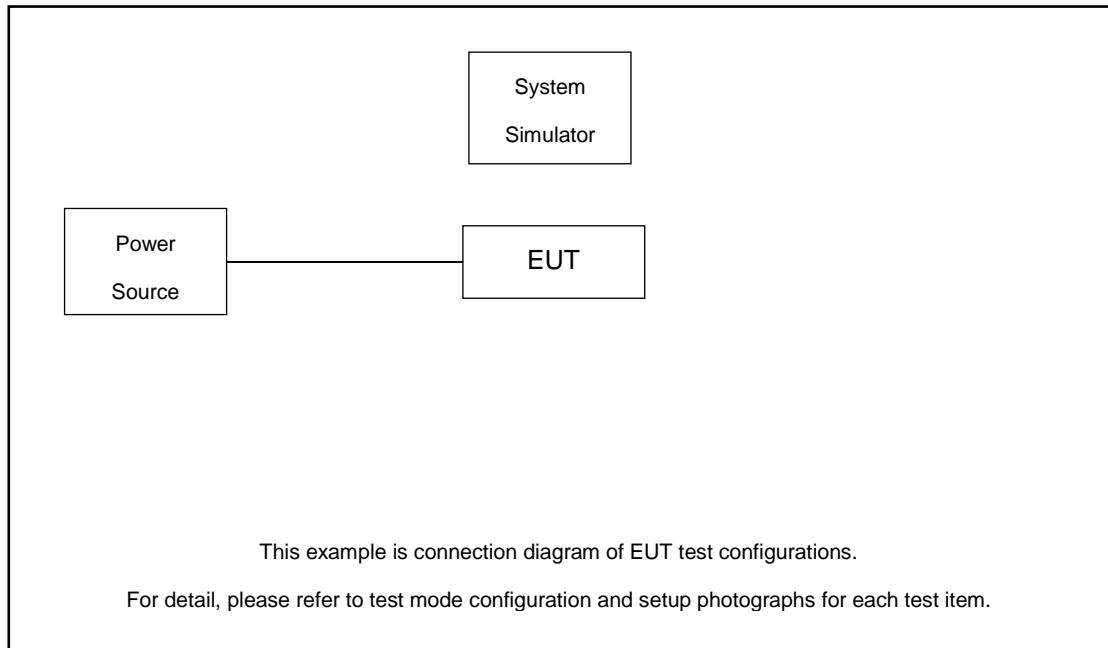

2.3 Support Unit used in test configuration and system

Item	Equipment	Trade Name	Model No.	FCC ID	Data Cable	Power Cord
1.	Power Supply	GWINSTEK	PSS-2002	N/A	N/A	Unshielded, 1.8 m
2.	LTE Base Station	Anritsu	MT8820C	N/A	N/A	Unshielded, 1.8 m

2.4 Measurement Results Explanation Example

For all conducted test items:

The offset level is set in the spectrum analyzer to compensate the RF cable loss between EUT conducted output port and spectrum analyzer. With the offset compensation, the spectrum analyzer reading level is exactly the EUT RF output level.

The spectrum analyzer offset is derived from RF cable loss.

Offset = RF cable loss.

Following shows an offset computation example with cable loss 8.9 dB.

Example :

$$\begin{aligned} \text{Offset(dB)} &= \text{RF cable loss(dB)}. \\ &= 8.9 \text{ (dB)} \end{aligned}$$

2.5 Frequency List of Low/Middle/High Channels

5G n77 Channel and Frequency List				
BW [MHz]	Channel/Frequency(MHz)	Lowest	Middle	Highest
100	Channel	-	633334	-
	Frequency	-	3500.01	-
90	Channel	633000	633334	633666
	Frequency	3495	3500.01	3504.99
80	Channel	632668	633334	634000
	Frequency	3490.02	3500.01	3510
60	Channel	632000	633334	634666
	Frequency	3480	3500.01	3519.99
50	Channel	631668	633334	635000
	Frequency	3475.02	3500.01	3525
40	Channel	631334	633334	635332
	Frequency	3470.01	3500.01	3529.98
20	Channel	630668	633334	636000
	Frequency	3460.02	3500.01	3540

5G n78 Channel and Frequency List				
BW [MHz]	Channel/Frequency(MHz)	Lowest	Middle	Highest
100	Channel	-	633334	-
	Frequency	-	3500.01	-
90	Channel	633000	633334	633666
	Frequency	3495	3500.01	3504.99
80	Channel	632668	633334	634000
	Frequency	3490.02	3500.01	3510
60	Channel	632000	633334	634666
	Frequency	3480	3500.01	3519.99
50	Channel	631668	633334	635000
	Frequency	3475.02	3500.01	3525
40	Channel	631334	633334	635332
	Frequency	3470.01	3500.01	3529.98
30	Channel	631000	633334	635666
	Frequency	3465	3500.01	3534.99
20	Channel	630668	633334	636000
	Frequency	3460.02	3500.01	3540

3 Conducted Test Items

3.1 Measuring Instruments

See list of measuring instruments of this test report.

3.2 Test Setup

3.2.1 Conducted Output Power

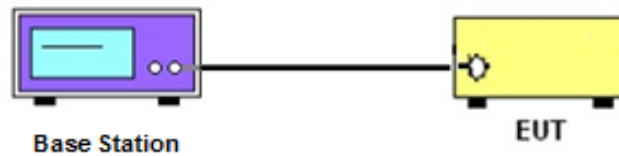

3.2.2 Peak-to-Average Ratio, Occupied / 26dB Bandwidth, Band-Edge and Conducted Spurious Emission

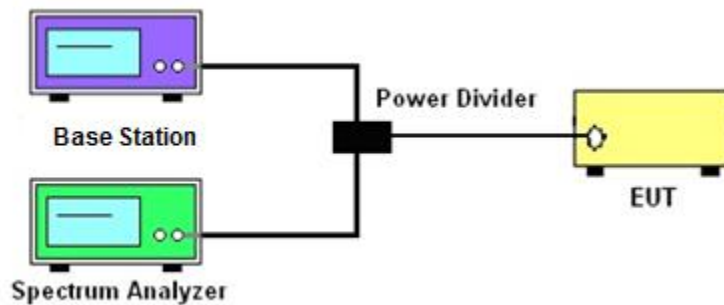

3.2.3 Frequency Stability

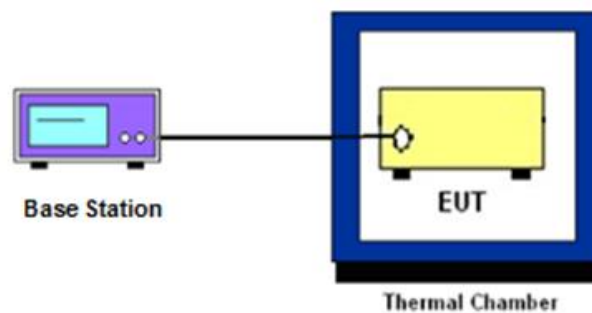

3.3 Test Result of Conducted Test

Please refer to Appendix A.



3.4 Conducted Output Power Measurement

3.4.1 Description of the Conducted Output Power Measurement

A base station simulator was used to establish communication with the EUT. Its parameters were set to transmit the maximum power on the EUT. The measured power in the radio frequency on the transmitter output terminals shall be reported.

3.4.2 Test Procedures

1. The testing follows ANSI C63.26 Section 5.2
2. The transmitter output port was connected to the system simulator.
3. Set EUT at maximum power through the system simulator.
4. Select lowest, middle, and highest channels for each band and different modulation.
5. Measure and record the power level from the system simulator.

3.5 Peak-to-Average Ratio

3.5.1 Description of the PAR Measurement

Power Complementary Cumulative Distribution Function (CCDF) curves provide a means for characterizing the power peaks of a digitally modulated signal on a statistical basis. A CCDF curve depicts the probability of the peak signal amplitude exceeding the average power level. Most contemporary measurement instrumentation include the capability to produce CCDF curves for an input signal provided that the instrument's resolution bandwidth can be set wide enough to accommodate the entire input signal bandwidth. In measuring transmissions in this band using an average power technique, the peak-to-average ratio (PAR) of the transmission may not exceed 13 dB.

3.5.2 Test Procedures

1. The testing follows ANSI C63.26 Section 5.2.3.4 (CCDF).
2. The EUT was connected to spectrum and system simulator via a power divider.
3. Set the CCDF (Complementary Cumulative Distribution Function) option in spectrum analyzer.
4. The highest RF powers were measured and recorded the maximum PAPR level associated with a probability of 0.1 %.
5. Record the deviation as Peak to Average Ratio.

3.6 EIRP

3.6.1 Description of EIRP Limit

§ 27.50 (k)(3)

Mobile devices are limited to 1Watt (30 dBm) EIRP. Mobile devices operating in these bands must employ a means for limiting power to the minimum necessary for successful communications

3.6.2 Test Procedures

1. According to KDB 412172 D01 Power Approach,
2. $EIRP = P_T + G_T - L_C$, $ERP = EIRP - 2.15$, where
 P_T = transmitter output power in dBm
 G_T = gain of the transmitting antenna in dBi
 L_C = signal attenuation in the connecting cable between the transmitter and antenna in dB

3.7 Occupied Bandwidth

3.7.1 Description of Occupied Bandwidth Measurement

The occupied bandwidth is the width of a frequency band such that, below the lower and above the upper frequency limits, the mean powers emitted are each equal to a specified percentage 0.5% of the total mean transmitted power.

The 26 dB emission bandwidth is defined as the frequency range between two points, one above and one below the carrier frequency, at which the spectral density of the emission is attenuated 26 dB below the maximum in-band spectral density of the modulated signal. Spectral density (power per unit bandwidth) is to be measured with a detector of resolution bandwidth equal to approximately 1.0% of the emission bandwidth.

3.7.2 Test Procedures

1. The testing follows ANSI C63.26 Section 5.4
2. The EUT was connected to spectrum analyzer and system simulator via a power divider.
3. The spectrum analyzer center frequency is set to the nominal EUT channel center frequency. The span range for the spectrum analyzer shall be between two and five times the anticipated OBW.
4. The nominal resolution bandwidth (RBW) shall be in the range of 1 to 5 % of the anticipated OBW, and the VBW shall be at least 3 times the RBW.
5. Set the detection mode to peak, and the trace mode to max hold.
6. Determine the reference value: Set the EUT to transmit a modulated signal. Allow the trace to stabilize. Set the spectrum analyzer marker to the highest level of the displayed trace.
(this is the reference value)
7. Determine the “-26 dB down amplitude” as equal to (Reference Value – X).
8. Place two markers, one at the lowest and the other at the highest frequency of the envelope of the spectral display such that each marker is at or slightly below the “-X dB down amplitude” determined in step 6. If a marker is below this “-X dB down amplitude” value it shall be placed as close as possible to this value. The OBW is the positive frequency difference between the two markers.
9. Use the 99 % power bandwidth function of the spectrum analyzer and report the measured bandwidth.

3.8 Conducted Band Edge Measurement

3.8.1 Description of Conducted Band Edge Measurement

§ 27.53 (n)(2)

For mobile operations in the 3450-3550 MHz band, the conducted power of any emission outside the licensee's authorized bandwidth shall not exceed -13 dBm/MHz.

Compliance with this paragraph is based on the use of measurement instrumentation employing a resolution bandwidth of 1 megahertz or greater. However, in the 1 megahertz bands immediately outside and adjacent to the licensee's frequency block, a resolution bandwidth of at least one percent of the emission bandwidth of the fundamental emission of the transmitter may be employed, but limited to a maximum of 200 kHz. In the bands between 1 and 5 MHz removed from the licensee's frequency block, the minimum resolution bandwidth for the measurement shall be 500 kHz.

3.8.2 Test Procedures

1. The testing follows ANSI C63.26 section 5.7
2. The EUT was connected to spectrum analyzer and system simulator via a power divider.
3. The band edges of low and high channels for the highest RF powers were measured.
4. Set RBW \geq 1% EBW but limited to a maximum of 200 kHz in the 1MHz band immediately outside and adjacent to the band edge.
5. Beyond the 1 MHz and 5 MHz removed from the band edge, set RBW \geq 500KHz.
6. Beyond the 5 MHz removed from the band edge, set RBW = 1MHz.
7. Set spectrum analyzer with RMS detector.
8. The RF fundamental frequency should be excluded against the limit line in the operating frequency band.
9. Checked that all the results comply with the emission limit line.

3.9 Conducted Spurious Emission Measurement

3.9.1 Description of Conducted Spurious Emission Measurement

The power of any emission outside of the authorized operating frequency ranges shall not exceed -13 dBm/MHz.

It is measured by means of a calibrated spectrum analyzer and scanned from 9 kHz up to a frequency including its 10th harmonic.

3.9.2 Test Procedures

1. The testing follows ANSI C63.26 section 5.7
2. The EUT was connected to spectrum analyzer and system simulator via a power divider.
3. The RF output of EUT was connected to the spectrum analyzer by RF cable and attenuator. The path loss was compensated to the results for each measurement.
4. The middle channel for the highest RF power within the transmitting frequency was measured.
5. The conducted spurious emission for the whole frequency range was taken.
6. Make the measurement with the spectrum analyzer's RBW = 1MHz, VBW = 3MHz.
7. Set spectrum analyzer with RMS detector.
8. Taking the record of maximum spurious emission.
9. The RF fundamental frequency should be excluded against the limit line in the operating frequency band.
10. Checked that all the results comply with the emission limit line.

3.10 Frequency Stability Measurement

3.10.1 Description of Frequency Stability Measurement

The frequency stability shall be measured by variation of ambient temperature and variation of primary supply voltage to ensure that the fundamental emission stays within the authorized frequency block.

3.10.2 Test Procedures for Temperature Variation

1. The testing follows ANSI C63.26 section 5.6.4
2. The EUT was set up in the thermal chamber and connected with the system simulator.
3. With power OFF, the temperature was decreased to -30°C and the EUT was stabilized before testing. Power was applied and the maximum change in frequency was recorded within one minute.
4. With power OFF, the temperature was raised in 10°C step up to 50°C. The EUT was stabilized at each step for at least half an hour. Power was applied and the maximum frequency change was recorded within one minute.

3.10.3 Test Procedures for Voltage Variation

1. The testing follows ANSI C63.26 section 5.6.5.
2. The EUT was placed in a temperature chamber at 20±5°C and connected with the system simulator.
3. The power supply voltage to the EUT was varied from 85% to 115% of the nominal value for other than hand carried battery equipment.
4. For hand carried, battery powered equipment, reduce the primary ac or dc supply voltage to the battery operating end point, which shall be specified by the manufacturer.
5. The variation in frequency was measured for the worst case.

4 Radiated Test Items

4.1 Measuring Instruments

See list of measuring instruments of this test report.

4.2 Test Setup

4.2.1 For radiated test below 30MHz

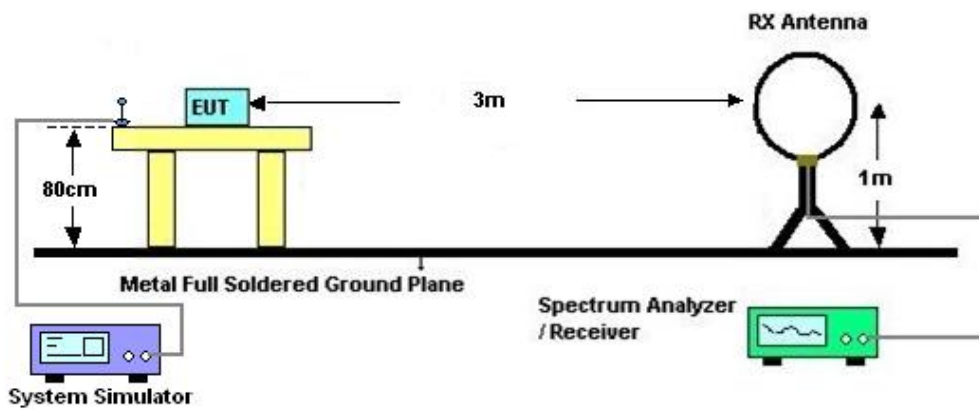

4.2.2 For radiated test from 30MHz to 1GHz

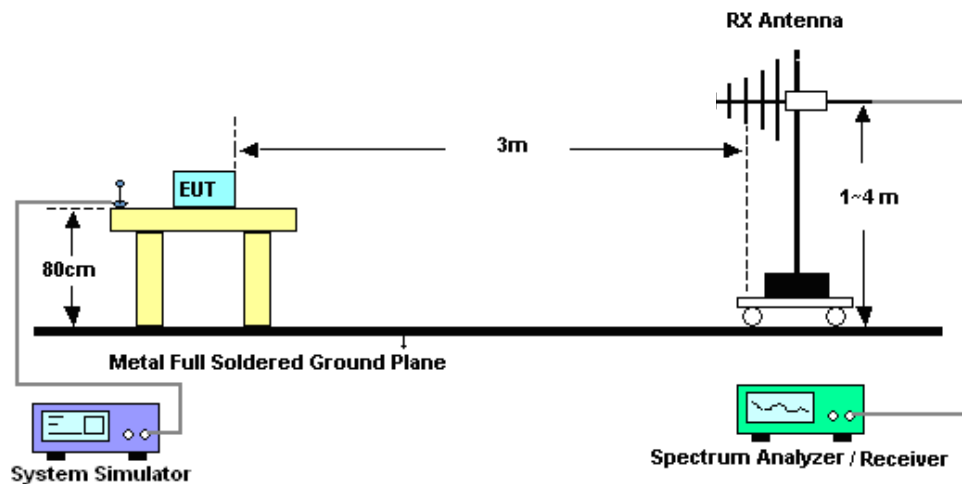

4.2.3 For radiated test above 1GHz

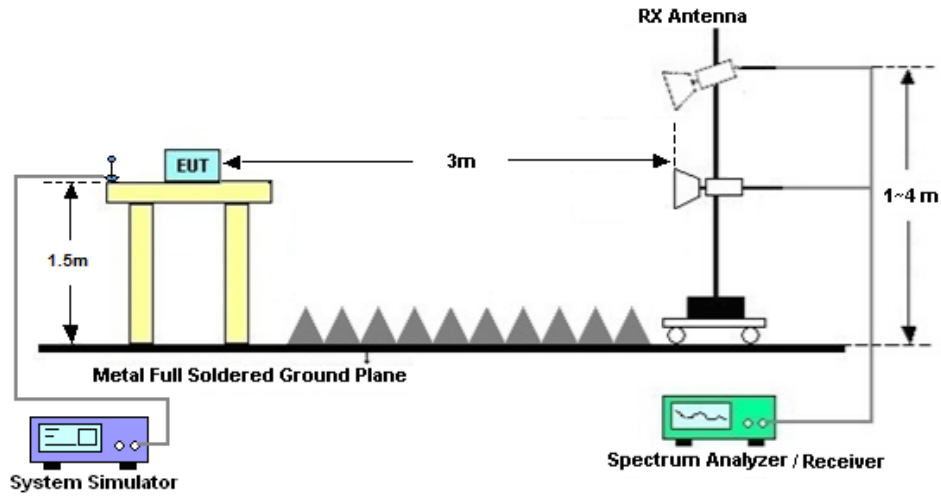

4.3 Test Result of Radiated Test

The low frequency, which started from 9 kHz to 30MHz, was pre-scanned and the result which was 20dB lower than the limit line was not reported.

Please refer to Appendix B.

4.4 Radiated Spurious Emission Measurement

4.4.1 Description of Radiated Spurious Emission

The radiated spurious emission was measured by substitution method according to ANSI/TIA-603-E. The power of any emission outside of the authorized operating frequency ranges shall not exceed -13 dBm/MHz.

The spectrum is scanned from 30 MHz up to a frequency including its 10th harmonic.

4.4.2 Test Procedures

1. The testing follows ANSI C63.26 Section 5.5
2. The EUT was placed on a turntable with 0.8 meter height for frequency below 1GHz and 1.5 meter height for frequency above 1GHz respectively above ground.
3. The EUT was set 3 meters from the receiving antenna mounted on the antenna tower.
4. The table was rotated 360 degrees to determine the position of the highest spurious emission.
5. The height of the receiving antenna is varied between 1m to 4m to search the maximum spurious emission for both horizontal and vertical polarizations.
6. During the measurement, the system simulator parameters were set to force the EUT transmitting at maximum output power.
7. Make the measurement with the spectrum analyzer's RBW = 1MHz, VBW = 3MHz, taking the record of maximum spurious emission.
8. A horn antenna was substituted in place of the EUT and was driven by a signal generator.
9. Tune the output power of signal generator to the same emission level with EUT maximum spurious emission.
$$\text{EIRP (dBm)} = \text{S.G. Power} - \text{Tx Cable Loss} + \text{Tx Antenna Gain}$$
$$\text{ERP (dBm)} = \text{EIRP} - 2.15$$
10. The RF fundamental frequency should be excluded against the limit line in the operating frequency band.



5 List of Measuring Equipment

Instrument	Manufacturer	Model No.	Serial No.	Characteristics	Calibration Date	Test Date	Due Date	Remark
Spectrum Analyzer	R&S	FSV40	101078	10Hz~40GHz	Apr. 07, 2022	Sep. 15, 2022~ Sep. 26, 2022	Apr. 08, 2023	Conducted (TH01-SZ)
DC Power Supply	TTI	PL330P	290070	Max 32V , 3A	Oct. 25, 2021	Sep. 15, 2022~ Sep. 26, 2022	Oct. 24, 2022	Conducted (TH01-SZ)
Power Divider	TOJOIN	PS-2SM-04 265	60.06.020.007 7	0.4GHz~26.5GHz	Dec. 25, 2021	Sep. 15, 2022~ Sep. 26, 2022	Dec. 24, 2022	Conducted (TH01-SZ)
Thermal Chamber	Ten Billion Hongzhangroup	LP-150U	H2014081803	-40~+150°C	Jul. 07, 2022	Sep. 15, 2022~ Sep. 26, 2022	Jul. 06, 2023	Conducted (TH01-SZ)
EXA Spectrum Analyzer	Keysight	N9010B	MY57471079	10Hz-44G,MAX 30dB	Oct. 14, 2021	Sep. 16, 2022	Oct. 13, 2022	Radiation (03CH04-KS)
Bilog Antenna	TeseQ	CBL6111D	49922	30MHz-1GHz	May 24, 2022	Sep. 16, 2022	May 23, 2023	Radiation (03CH04-KS)
Horn Antenna	Schwarzbeck	BBHA9120D	1284	1GHz~18GHz	Jan. 05, 2022	Sep. 16, 2022	Jan. 04, 2023	Radiation (03CH04-KS)
SHF-EHF Horn	Com-power	AH-840	101070	18GHz~40GHz	Jan. 05, 2022	Sep. 16, 2022	Jan. 04, 2023	Radiation (03CH04-KS)
Amplifier	SONOMA	310N	187289	9KHz-1GHz	Jan. 05, 2022	Sep. 16, 2022	Jan. 04, 2023	Radiation (03CH04-KS)
Amplifier	MITEQ	EM18G40G GA	060728	18~40GHz	Jan. 05, 2022	Sep. 16, 2022	Jan. 04, 2023	Radiation (03CH04-KS)
high gain Amplifier	EM	EM01G18G A	060839	1Ghz-18Ghz	Oct. 14, 2021	Sep. 16, 2022	Oct. 13, 2022	Radiation (03CH04-KS)
Amplifier	Keysight	83017A	MY57280106	500MHz~26.5GHz	Oct. 13, 2021	Sep. 16, 2022	Oct. 12, 2022	Radiation (03CH04-KS)
AC Power Source	Chroma	61601	F104090004	N/A	NCR	Sep. 16, 2022	NCR	Radiation (03CH04-KS)
Turn Table	ChamPro	EM 1000-T	060762-T	0~360 degree	NCR	Sep. 16, 2022	NCR	Radiation (03CH04-KS)
Antenna Mast	ChamPro	EM 1000-A	060762-A	1 m~4 m	NCR	Sep. 16, 2022	NCR	Radiation (03CH04-KS)

NCR: No Calibration Required

6 Uncertainty of Evaluation

The measurement uncertainties shown below were calculated in accordance with the requirements of ANSI 63.26-2015. All the measurement uncertainty value were shown with a coverage $K=2$ to indicate 95% level of confidence. The measurement data show herein meets or exceeds the CISPR measurement uncertainty values specified in CISPR 16-4-2 and can be compared directly to specified limit to determine compliance.

Uncertainty of Radiated Emission Measurement (30 MHz ~ 1000 MHz)

Measuring Uncertainty for a Level of Confidence of 95% ($U = 2Uc(y)$)	3.3dB
---	-------

Uncertainty of Radiated Emission Measurement (1 GHz ~ 18 GHz)

Measuring Uncertainty for a Level of Confidence of 95% ($U = 2Uc(y)$)	2.8dB
---	-------

Uncertainty of Radiated Emission Measurement (18 GHz ~ 40 GHz)

Measuring Uncertainty for a Level of Confidence of 95% ($U = 2Uc(y)$)	2.8dB
---	-------

----- THE END -----



Appendix A. Test Results of Conducted Test

Test Engineer :	Jung Guo	Temperature :	22~23°C
		Relative Humidity :	40~42%

FR1 N77 (ANT2)

Transmitter Conducted Output Power And EIRP, ($G_T - L_C$)=1.1dB

NR Band	SCS (kHz)	Bandwidth (MHz)	Arfcn	Freq (MHz)	Modulation	RB	Conducted Power(dBm)	EIRP (dBm)	EIRP (W)
77	30	20	630668	3460.02	DFT-s-OFDM QPSK	1@1	27.24	28.34	0.6823
77	30	20	630668	3460.02	DFT-s-OFDM 16 QAM	1@1	26.06	27.16	0.5200
77	30	20	633334	3500.01	DFT-s-OFDM QPSK	1@1	27.24	28.34	0.6823
77	30	20	633334	3500.01	DFT-s-OFDM 16 QAM	1@1	26.16	27.26	0.5321
77	30	20	636000	3540	DFT-s-OFDM QPSK	1@1	27.24	28.34	0.6823
77	30	20	636000	3540	DFT-s-OFDM 16 QAM	1@1	26.32	27.42	0.5521
77	30	40	631334	3470.01	DFT-s-OFDM QPSK	1@1	26.86	27.96	0.6252
77	30	40	631334	3470.01	DFT-s-OFDM 16 QAM	1@1	25.65	26.75	0.4732
77	30	40	633334	3500.01	DFT-s-OFDM QPSK	1@1	26.97	28.07	0.6412
77	30	40	633334	3500.01	DFT-s-OFDM 16 QAM	1@1	25.84	26.94	0.4943
77	30	40	635332	3529.98	DFT-s-OFDM QPSK	1@1	27.05	28.15	0.6531
77	30	40	635332	3529.98	DFT-s-OFDM 16 QAM	1@1	25.87	26.97	0.4977
77	30	50	631668	3475.02	DFT-s-OFDM QPSK	1@1	27.12	28.22	0.6637
77	30	50	631668	3475.02	DFT-s-OFDM 16 QAM	1@1	25.93	27.03	0.5047
77	30	50	633334	3500.01	DFT-s-OFDM QPSK	1@1	27.23	28.33	0.6808
77	30	50	633334	3500.01	DFT-s-OFDM 16 QAM	1@1	26.1	27.2	0.5248
77	30	50	635000	3525	DFT-s-OFDM QPSK	1@1	27.24	28.34	0.6823
77	30	50	635000	3525	DFT-s-OFDM 16 QAM	1@1	26.08	27.18	0.5224
77	30	60	632000	3480	DFT-s-OFDM QPSK	1@1	27.04	28.14	0.6516
77	30	60	632000	3480	DFT-s-OFDM 16 QAM	1@1	25.76	26.86	0.4853
77	30	60	633334	3500.01	DFT-s-OFDM QPSK	1@1	27.17	28.27	0.6714
77	30	60	633334	3500.01	DFT-s-OFDM 16 QAM	1@1	25.9	27	0.5012
77	30	60	634666	3519.99	DFT-s-OFDM QPSK	1@1	27.18	28.28	0.6730

77	30	60	634666	3519.99	DFT-s-OFDM 16 QAM	1@1	25.99	27.09	0.5117
77	30	80	632668	3490.02	DFT-s-OFDM QPSK	1@1	26.65	27.75	0.5957
77	30	80	632668	3490.02	DFT-s-OFDM 16 QAM	1@1	25.54	26.64	0.4613
77	30	80	633334	3500.01	DFT-s-OFDM QPSK	1@1	26.72	27.82	0.6053
77	30	80	633334	3500.01	DFT-s-OFDM 16 QAM	1@1	25.58	26.68	0.4656
77	30	80	634000	3510	DFT-s-OFDM QPSK	1@1	26.8	27.9	0.6166
77	30	80	634000	3510	DFT-s-OFDM 16 QAM	1@1	25.77	26.87	0.4864
77	30	90	633000	3495	DFT-s-OFDM QPSK	1@1	26.65	27.75	0.5957
77	30	90	633000	3495	DFT-s-OFDM 16 QAM	1@1	25.39	26.49	0.4457
77	30	90	633334	3500.01	DFT-s-OFDM QPSK	1@1	26.64	27.74	0.5943
77	30	90	633334	3500.01	DFT-s-OFDM 16 QAM	1@1	25.52	26.62	0.4592
77	30	90	633666	3504.99	DFT-s-OFDM QPSK	1@1	26.71	27.81	0.6039
77	30	90	633666	3504.99	DFT-s-OFDM 16 QAM	1@1	25.59	26.69	0.4667
77	30	100	633334	3500.01	DFT-s-OFDM PI/2 BPSK	135@67	27.24	28.34	0.6823
77	30	100	633334	3500.01	DFT-s-OFDM PI/2 BPSK	1@1	26.27	27.37	0.5458
77	30	100	633334	3500.01	DFT-s-OFDM PI/2 BPSK	1@271	26.23	27.33	0.5408
77	30	100	633334	3500.01	DFT-s-OFDM QPSK	135@67	27.25	28.35	0.6839
77	30	100	633334	3500.01	DFT-s-OFDM QPSK	1@1	26.55	27.65	0.5821
77	30	100	633334	3500.01	DFT-s-OFDM QPSK	1@271	26.47	27.57	0.5715
77	30	100	633334	3500.01	DFT-s-OFDM 16 QAM	135@67	26.32	27.42	0.5521
77	30	100	633334	3500.01	DFT-s-OFDM 16 QAM	1@1	25.31	26.41	0.4375
77	30	100	633334	3500.01	DFT-s-OFDM 16 QAM	1@271	25.27	26.37	0.4335
77	30	100	633334	3500.01	DFT-s-OFDM 64 QAM	135@67	24.84	25.94	0.3926
77	30	100	633334	3500.01	DFT-s-OFDM 64 QAM	1@1	23.81	24.91	0.3097
77	30	100	633334	3500.01	DFT-s-OFDM 64 QAM	1@271	23.73	24.83	0.3041
77	30	100	633334	3500.01	DFT-s-OFDM 256 QAM	135@67	22.81	23.91	0.2460
77	30	100	633334	3500.01	DFT-s-OFDM 256 QAM	1@1	21.44	22.54	0.1795

77	30	100	633334	3500.01	DFT-s-OFDM 256 QAM	1@271	21.3	22.4	0.1738
77	30	100	633334	3500.01	CP-OFDM QPSK	137@68	25.78	26.88	0.4875
77	30	100	633334	3500.01	CP-OFDM QPSK	1@1	24.89	25.99	0.3972
77	30	100	633334	3500.01	CP-OFDM QPSK	1@271	24.79	25.89	0.3882

FR1 N78 (ANT2)

Transmitter Conducted Output Power And EIRP, (G_T - L_C)=1.1dB

NR Band	SCS (kHz)	Bandwidth (MHz)	Arfcn	Freq (MHz)	Modulation	RB	Conducted Power(dBm)	EIRP (dBm)	EIRP (W)
78	30	20	630668	3460.02	DFT-s-OFDM QPSK	1@1	27.1	28.2	0.6607
78	30	20	630668	3460.02	DFT-s-OFDM 16 QAM	1@1	25.79	26.89	0.4887
78	30	20	633334	3500.01	DFT-s-OFDM QPSK	1@1	27.11	28.21	0.6622
78	30	20	633334	3500.01	DFT-s-OFDM 16 QAM	1@1	25.82	26.92	0.4920
78	30	20	636000	3540.0	DFT-s-OFDM QPSK	1@1	27.19	28.29	0.6745
78	30	20	636000	3540.0	DFT-s-OFDM 16 QAM	1@1	25.88	26.98	0.4989
78	30	30	631000	3465.0	DFT-s-OFDM QPSK	1@1	26.87	27.97	0.6266
78	30	30	631000	3465.0	DFT-s-OFDM 16 QAM	1@1	25.52	26.62	0.4592
78	30	30	633334	3500.01	DFT-s-OFDM QPSK	1@1	26.96	28.06	0.6397
78	30	30	633334	3500.01	DFT-s-OFDM 16 QAM	1@1	25.76	26.86	0.4853
78	30	30	635666	3534.99	DFT-s-OFDM QPSK	1@1	27.02	28.12	0.6486
78	30	30	635666	3534.99	DFT-s-OFDM 16 QAM	1@1	25.8	26.9	0.4898
78	30	40	631334	3470.01	DFT-s-OFDM QPSK	1@1	26.57	27.67	0.5848
78	30	40	631334	3470.01	DFT-s-OFDM 16 QAM	1@1	25.36	26.46	0.4426
78	30	40	633334	3500.01	DFT-s-OFDM QPSK	1@1	26.73	27.83	0.6067
78	30	40	633334	3500.01	DFT-s-OFDM 16 QAM	1@1	25.54	26.64	0.4613
78	30	40	635332	3529.98	DFT-s-OFDM QPSK	1@1	26.8	27.9	0.6166
78	30	40	635332	3529.98	DFT-s-OFDM 16 QAM	1@1	25.48	26.58	0.4550
78	30	50	631668	3475.02	DFT-s-OFDM QPSK	1@1	26.87	27.97	0.6266
78	30	50	631668	3475.02	DFT-s-OFDM 16 QAM	1@1	25.63	26.73	0.4710
78	30	50	633334	3500.01	DFT-s-OFDM QPSK	1@1	27.26	28.36	0.6855
78	30	50	633334	3500.01	DFT-s-OFDM 16 QAM	1@1	26.02	27.12	0.5152

78	30	50	635000	3525.0	DFT-s-OFDM QPSK	1@1	26.63	27.73	0.5929
78	30	50	635000	3525.0	DFT-s-OFDM 16 QAM	1@1	25.34	26.44	0.4406
78	30	60	632000	3480.0	DFT-s-OFDM QPSK	1@1	27.08	28.18	0.6577
78	30	60	632000	3480.0	DFT-s-OFDM 16 QAM	1@1	25.76	26.86	0.4853
78	30	60	633334	3500.01	DFT-s-OFDM QPSK	1@1	27.1	28.2	0.6607
78	30	60	633334	3500.01	DFT-s-OFDM 16 QAM	1@1	25.86	26.96	0.4966
78	30	60	634666	3519.99	DFT-s-OFDM QPSK	1@1	27.16	28.26	0.6699
78	30	60	634666	3519.99	DFT-s-OFDM 16 QAM	1@1	26.04	27.14	0.5176
78	30	80	632668	3490.02	DFT-s-OFDM QPSK	1@1	26.58	27.68	0.5861
78	30	80	632668	3490.02	DFT-s-OFDM 16 QAM	1@1	25.51	26.61	0.4581
78	30	80	633334	3500.01	DFT-s-OFDM QPSK	1@1	26.49	27.59	0.5741
78	30	80	633334	3500.01	DFT-s-OFDM 16 QAM	1@1	25.38	26.48	0.4446
78	30	80	634000	3510.0	DFT-s-OFDM QPSK	1@1	26.77	27.87	0.6124
78	30	80	634000	3510.0	DFT-s-OFDM 16 QAM	1@1	25.62	26.72	0.4699
78	30	90	633000	3495.0	DFT-s-OFDM QPSK	1@1	26.49	27.59	0.5741
78	30	90	633000	3495.0	DFT-s-OFDM 16 QAM	1@1	25.32	26.42	0.4385
78	30	90	633334	3500.01	DFT-s-OFDM QPSK	1@1	26.56	27.66	0.5834
78	30	90	633334	3500.01	DFT-s-OFDM 16 QAM	1@1	25.43	26.53	0.4498
78	30	90	633666	3504.99	DFT-s-OFDM QPSK	1@1	26.65	27.75	0.5957
78	30	90	633666	3504.99	DFT-s-OFDM 16 QAM	1@1	25.54	26.64	0.4613
78	30	100	633334	3500.01	DFT-s-OFDM PI/2 BPSK	135@67	27.15	28.25	0.6683
78	30	100	633334	3500.01	DFT-s-OFDM PI/2 BPSK	1@1	26.17	27.27	0.5333
78	30	100	633334	3500.01	DFT-s-OFDM PI/2 BPSK	1@271	26.06	27.16	0.5200
78	30	100	633334	3500.01	DFT-s-OFDM QPSK	135@67	27.41	28.51	0.7096
78	30	100	633334	3500.01	DFT-s-OFDM QPSK	1@1	26.46	27.56	0.5702
78	30	100	633334	3500.01	DFT-s-OFDM QPSK	1@271	26.21	27.31	0.5383
78	30	100	633334	3500.01	DFT-s-OFDM 16 QAM	135@67	26.22	27.32	0.5395

78	30	100	633334	3500.01	DFT-s-OFDM 16 QAM	1@1	25.21	26.31	0.4276
78	30	100	633334	3500.01	DFT-s-OFDM 16 QAM	1@271	25.1	26.2	0.4169
78	30	100	633334	3500.01	DFT-s-OFDM 64 QAM	135@67	24.71	25.81	0.3811
78	30	100	633334	3500.01	DFT-s-OFDM 64 QAM	1@1	23.75	24.85	0.3055
78	30	100	633334	3500.01	DFT-s-OFDM 64 QAM	1@271	23.56	24.66	0.2924
78	30	100	633334	3500.01	DFT-s-OFDM 256 QAM	135@67	22.71	23.81	0.2404
78	30	100	633334	3500.01	DFT-s-OFDM 256 QAM	1@1	21.31	22.41	0.1742
78	30	100	633334	3500.01	DFT-s-OFDM 256 QAM	1@271	21.2	22.3	0.1698
78	30	100	633334	3500.01	CP-OFDM QPSK	137@68	25.7	26.8	0.4786
78	30	100	633334	3500.01	CP-OFDM QPSK	1@1	24.66	25.76	0.3767
78	30	100	633334	3500.01	CP-OFDM QPSK	1@271	24.49	25.59	0.3622

Frequency Stability

NR Band	SCS (kHz)	Bandwidth (MHz)	Arfcn	Freq (MHz)	Modulation	RB	Deviation (ppm)	Verdict	Environment
78	30	20	633334	3500.01	DFT-s-OFDM QPSK	50@0	0.0024	PASS	NV
78	30	20	633334	3500.01	DFT-s-OFDM QPSK	50@0	0.0048	PASS	LV
78	30	20	633334	3500.01	DFT-s-OFDM QPSK	50@0	0.0022	PASS	HV
78	30	20	633334	3500.01	DFT-s-OFDM QPSK	50@0	0.0048	PASS	-30°C
78	30	20	633334	3500.01	DFT-s-OFDM QPSK	50@0	0.0021	PASS	-20°C
78	30	20	633334	3500.01	DFT-s-OFDM QPSK	50@0	0.0042	PASS	-10°C
78	30	20	633334	3500.01	DFT-s-OFDM QPSK	50@0	0.0055	PASS	0°C
78	30	20	633334	3500.01	DFT-s-OFDM QPSK	50@0	0.0029	PASS	10°C
78	30	20	633334	3500.01	DFT-s-OFDM QPSK	50@0	0.0024	PASS	20°C
78	30	20	633334	3500.01	DFT-s-OFDM QPSK	50@0	0.0045	PASS	30°C
78	30	20	633334	3500.01	DFT-s-OFDM QPSK	50@0	0.0053	PASS	40°C
78	30	20	633334	3500.01	DFT-s-OFDM QPSK	50@0	0.0068	PASS	50°C

Peak to Average Ratio

NR Band	SCS (kHz)	Bandwidth (MHz)	Arfcn	Freq (MHz)	Modulation	RB	Result (dB)	Limit (dB)	Verdict
78	30	20	630668	3460.02	DFT-s-OFDM PI/2 BPSK	50@0	6.81	13	PASS
78	30	20	630668	3460.02	DFT-s-OFDM PI/2 BPSK	1@0	7.5	13	PASS
78	30	20	630668	3460.02	DFT-s-OFDM QPSK	50@0	7.8	13	PASS
78	30	20	630668	3460.02	DFT-s-OFDM QPSK	1@0	7.81	13	PASS
78	30	20	633334	3500.01	DFT-s-OFDM PI/2 BPSK	50@0	6.83	13	PASS
78	30	20	633334	3500.01	DFT-s-OFDM PI/2 BPSK	1@0	8.07	13	PASS
78	30	20	633334	3500.01	DFT-s-OFDM QPSK	50@0	7.85	13	PASS
78	30	20	633334	3500.01	DFT-s-OFDM QPSK	1@0	7.65	13	PASS
78	30	20	636000	3540.0	DFT-s-OFDM PI/2 BPSK	50@0	6.88	13	PASS
78	30	20	636000	3540.0	DFT-s-OFDM PI/2 BPSK	1@0	7.54	13	PASS
78	30	20	636000	3540.0	DFT-s-OFDM QPSK	50@0	7.87	13	PASS
78	30	20	636000	3540.0	DFT-s-OFDM QPSK	1@0	8.91	13	PASS

N78(20M)_DFT-s-OFDM_PI_2-BPSK_Outer_Full_Low_CH

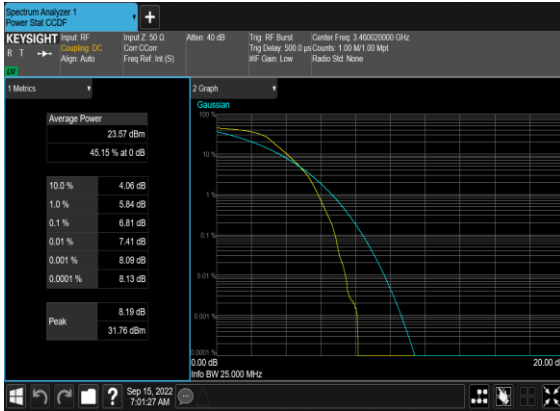

N78(20M)_DFT-s-OFDM_PI_2-BPSK_Edge_1RB_Left_Low_CH



N78(20M)_DFT-s-OFDM_QPSK_Outer_Full_Low_CH

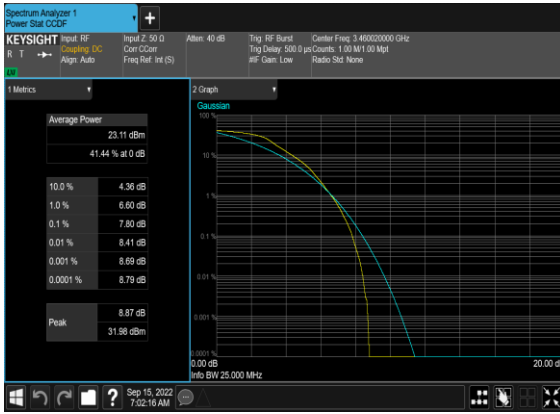

N78(20M)_DFT-s-OFDM_QPSK_Edge_1RB_Left_Low_CH

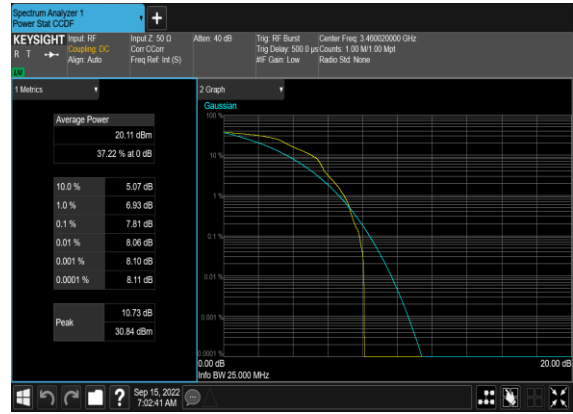

N78(20M)_DFT-s-OFDM_PI_2-BPSK_Outer_Full_Mid_CH



N78(20M)_DFT-s-OFDM_PI_2-BPSK_Edge_1RB_Left_Mid_CH



N78(20M)_DFT-s-OFDM_QPSK_Outer_Full_Mid_CH

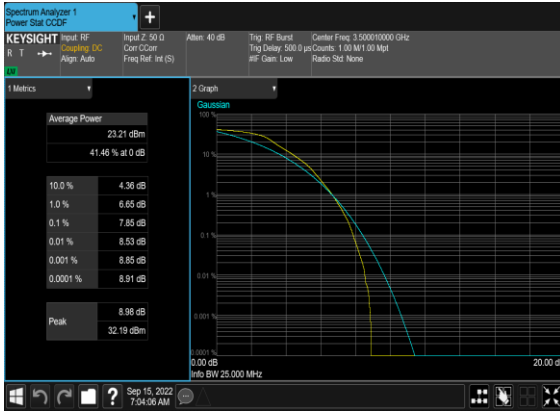

N78(20M)_DFT-s-OFDM_QPSK_Edge_1RB_Left_Mid_CH

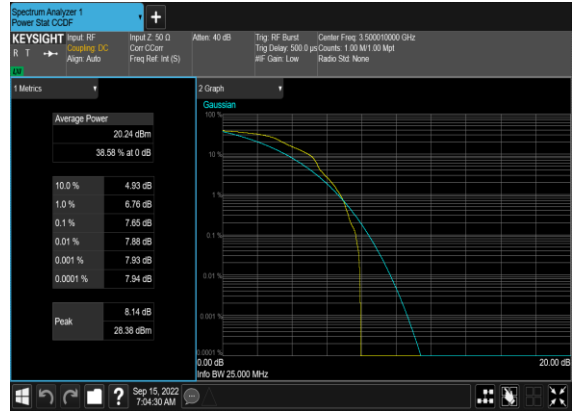

N78(20M)_DFT-s-OFDM_PI_2-BPSK_Outer_Full_High_CH



N78(20M)_DFT-s-OFDM_PI_2-BPSK_Edge_1RB_Left_High_CH



N78(20M)_DFT-s-OFDM_QPSK_Outer_Full_High_CH



N78(20M)_DFT-s-OFDM_QPSK_Edge_1RB_Left_High_CH

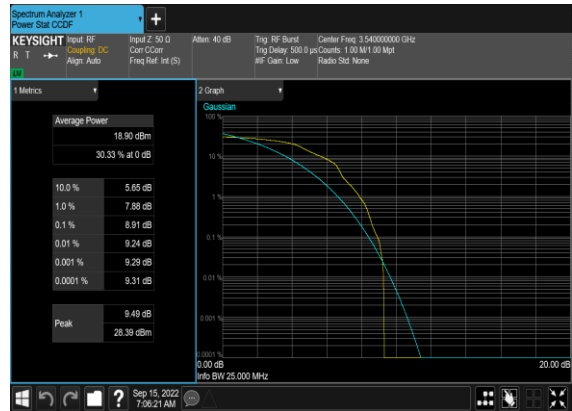

Occupied Bandwidth

NR Band	SCS (kHz)	Bandwidth (MHz)	Arfcn	Freq (MHz)	Modulation	RB	OBW (MHz)	26dB OBW (MHz)
78	30	20	633334	3500.01	DFT-s-OFDM PI/2 BPSK	50@0	17.805	19.01
78	30	20	633334	3500.01	DFT-s-OFDM QPSK	50@0	17.811	18.94
78	30	20	633334	3500.01	CP-OFDM QPSK	51@0	18.137	20.06
78	30	20	633334	3500.01	CP-OFDM 16 QAM	51@0	18.208	19.28
78	30	20	633334	3500.01	CP-OFDM 64 QAM	51@0	18.217	19.21
78	30	20	633334	3500.01	CP-OFDM 256 QAM	51@0	18.18	19.35
78	30	30	633334	3500.01	DFT-s-OFDM PI/2 BPSK	75@0	26.742	28.35
78	30	30	633334	3500.01	DFT-s-OFDM QPSK	75@0	26.763	28.28
78	30	30	633334	3500.01	CP-OFDM QPSK	78@0	27.776	29.04
78	30	30	633334	3500.01	CP-OFDM 16 QAM	78@0	27.858	29.26
78	30	30	633334	3500.01	CP-OFDM 64 QAM	78@0	27.85	29.34
78	30	30	633334	3500.01	CP-OFDM 256 QAM	78@0	27.79	29.64
78	30	40	633334	3500.01	DFT-s-OFDM PI/2 BPSK	100@0	35.716	37.24
78	30	40	633334	3500.01	DFT-s-OFDM QPSK	100@0	35.744	37.47
78	30	40	633334	3500.01	CP-OFDM QPSK	106@0	37.793	39.53
78	30	40	633334	3500.01	CP-OFDM 16 QAM	106@0	37.811	39.33
78	30	40	633334	3500.01	CP-OFDM 64 QAM	106@0	37.867	39.52
78	30	40	633334	3500.01	CP-OFDM 256 QAM	106@0	37.871	39.58
78	30	50	633334	3500.01	DFT-s-OFDM PI/2 BPSK	128@0	45.716	47.86
78	30	50	633334	3500.01	DFT-s-OFDM QPSK	128@0	45.76	48.12
78	30	50	633334	3500.01	CP-OFDM QPSK	133@0	47.451	49.31
78	30	50	633334	3500.01	CP-OFDM 16 QAM	133@0	47.445	49.24
78	30	50	633334	3500.01	CP-OFDM 64 QAM	133@0	47.397	49.43
78	30	50	633334	3500.01	CP-OFDM 256 QAM	133@0	47.53	49.71
78	30	60	633334	3500.01	DFT-s-OFDM PI/2 BPSK	162@0	57.831	59.92

78	30	60	633334	3500.01	DFT-s-OFDM QPSK	162@0	57.869	59.77
78	30	60	633334	3500.01	CP-OFDM QPSK	162@0	57.875	59.87
78	30	60	633334	3500.01	CP-OFDM 16 QAM	162@0	57.848	59.8
78	30	60	633334	3500.01	CP-OFDM 64 QAM	162@0	57.816	59.98
78	30	60	633334	3500.01	CP-OFDM 256 QAM	162@0	57.758	60.04
78	30	80	633334	3500.01	DFT-s-OFDM PI/2 BPSK	216@0	77.109	79.62
78	30	80	633334	3500.01	DFT-s-OFDM QPSK	216@0	77.131	79.69
78	30	80	633334	3500.01	CP-OFDM QPSK	217@0	77.528	80.18
78	30	80	633334	3500.01	CP-OFDM 16 QAM	217@0	77.356	79.98
78	30	80	633334	3500.01	CP-OFDM 64 QAM	217@0	77.448	80.07
78	30	80	633334	3500.01	CP-OFDM 256 QAM	217@0	77.389	79.89
78	30	90	633334	3500.01	DFT-s-OFDM PI/2 BPSK	240@0	85.891	88.72
78	30	90	633334	3500.01	DFT-s-OFDM QPSK	240@0	85.643	88.75
78	30	90	633334	3500.01	CP-OFDM QPSK	245@0	87.458	90.32
78	30	90	633334	3500.01	CP-OFDM 16 QAM	245@0	87.546	90.37
78	30	90	633334	3500.01	CP-OFDM 64 QAM	245@0	87.46	90.11
78	30	90	633334	3500.01	CP-OFDM 256 QAM	245@0	87.319	90.26
78	30	100	633334	3500.01	DFT-s-OFDM PI/2 BPSK	270@0	96.468	99.8
78	30	100	633334	3500.01	DFT-s-OFDM QPSK	270@0	96.117	99.5
78	30	100	633334	3500.01	CP-OFDM QPSK	273@0	97.395	100.6
78	30	100	633334	3500.01	CP-OFDM 16 QAM	273@0	97.306	100.5
78	30	100	633334	3500.01	CP-OFDM 64 QAM	273@0	97.266	100.5
78	30	100	633334	3500.01	CP-OFDM 256 QAM	273@0	97.279	100.4

N78(20M)_DFT-s-OFDM_PI_2-BPSK_Outer_Full_Mid_CH

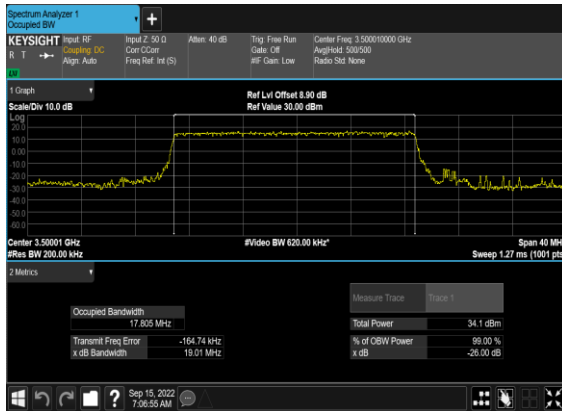

N78(20M)_DFT-s-OFDM_QPSK_Outer_Full_Mid_CH

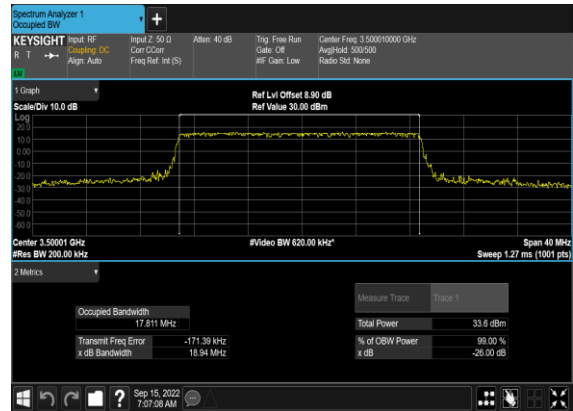

N78(20M)_CP-OFDM_QPSK_Outer_Full_Mid_CH

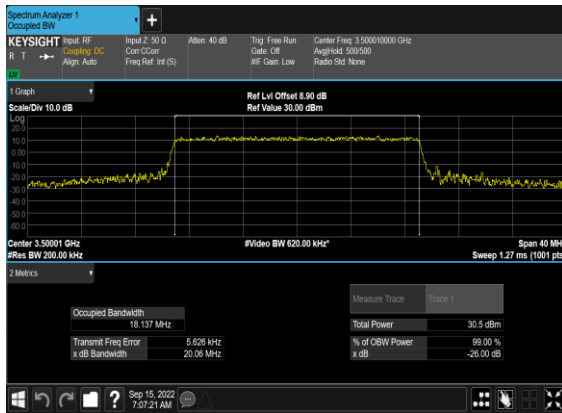

N78(20M)_CP-OFDM_16QAM_Outer_Full_Mid_CH

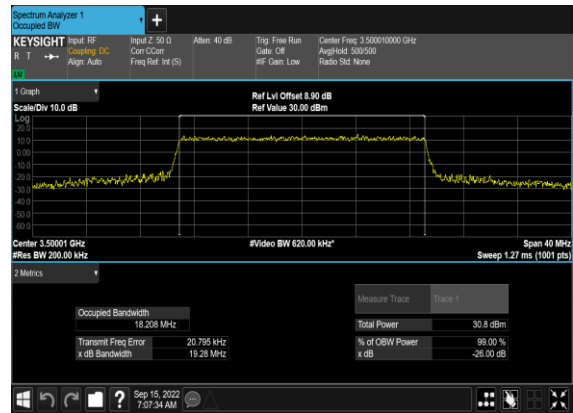

N78(20M)_CP-OFDM_64QAM_Outer_Full_Mid_CH

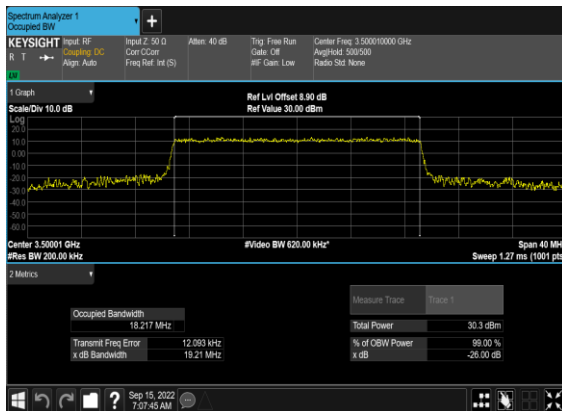

N78(20M)_CP-OFDM_256QAM_Outer_Full_Mid_CH

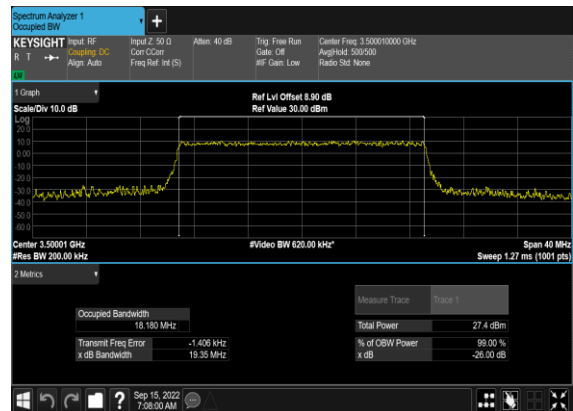

N78(30M)_DFT-s-OFDM_PI_2-BPSK_Outer_Full_Mid_CH

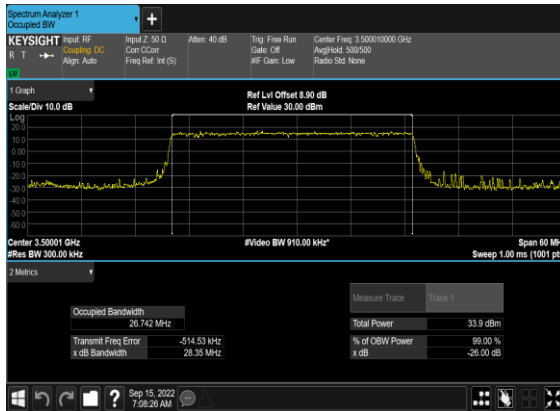

N78(30M)_DFT-s-OFDM_QPSK_Outer_Full_Mid_CH

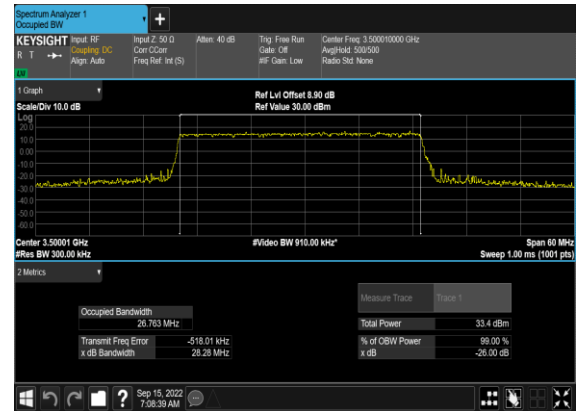

N78(30M)_CP-OFDM_QPSK_Outer_Full_Mid_CH

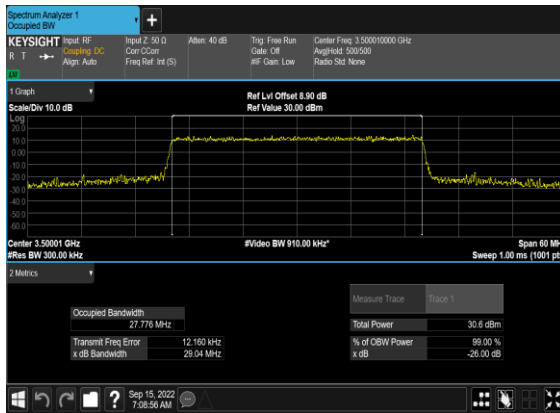

N78(30M)_CP-OFDM_16QAM_Outer_Full_Mid_CH

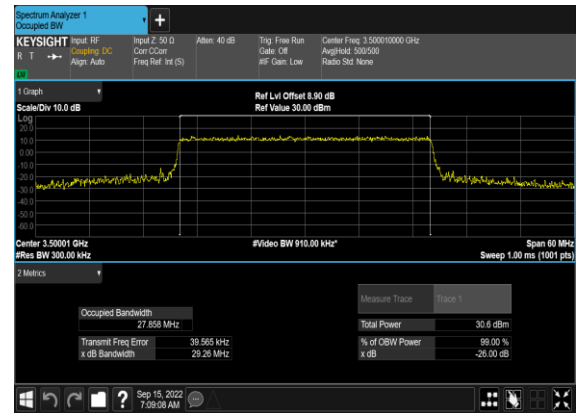

N78(30M)_CP-OFDM_64QAM_Outer_Full_Mid_CH

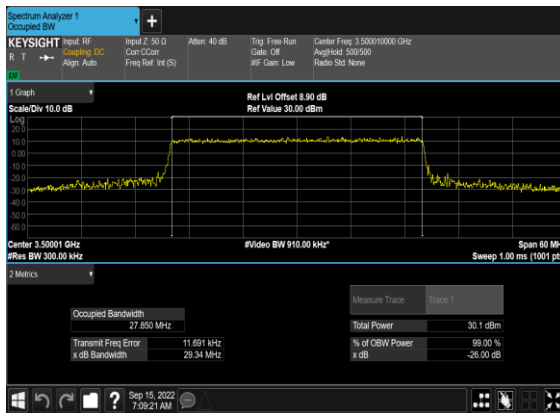

N78(30M)_CP-OFDM_256QAM_Outer_Full_Mid_CH

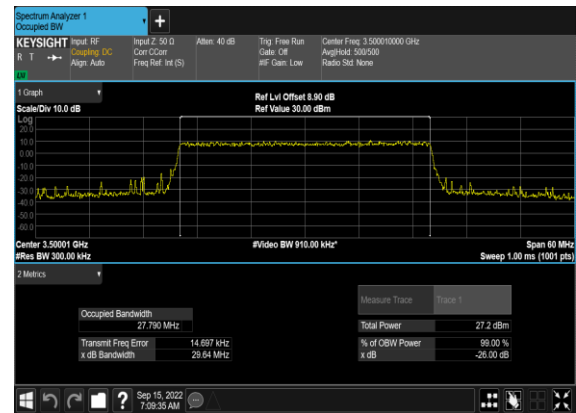

N78(40M)_DFT-s-OFDM_PI_2-BPSK_Outer_Full_Mid_CH

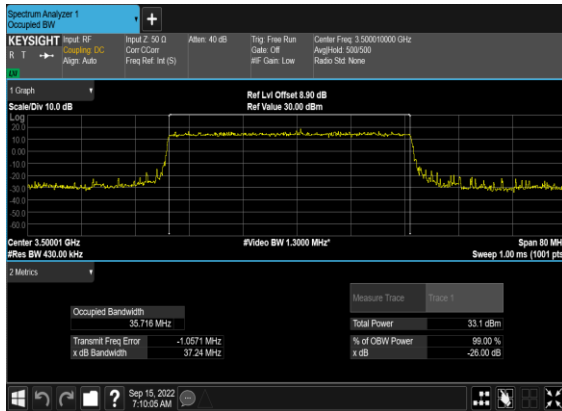

N78(40M)_DFT-s-OFDM_QPSK_Outer_Full_Mid_CH

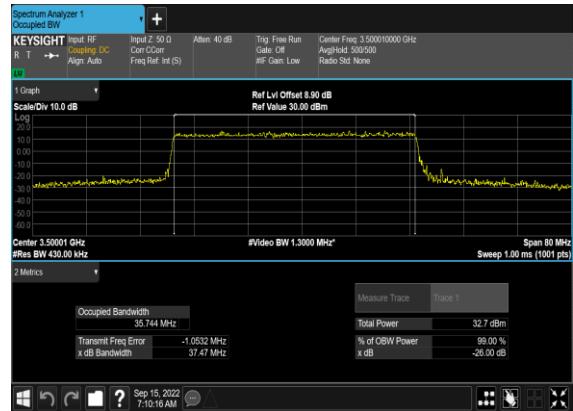

N78(40M)_CP-OFDM_QPSK_Outer_Full_Mid_CH

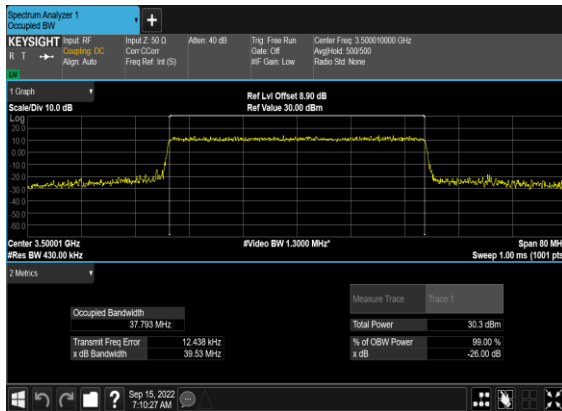

N78(40M)_CP-OFDM_16QAM_Outer_Full_Mid_CH

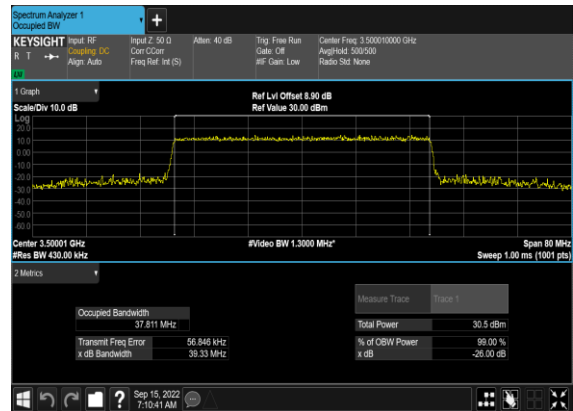

N78(40M)_CP-OFDM_64QAM_Outer_Full_Mid_CH

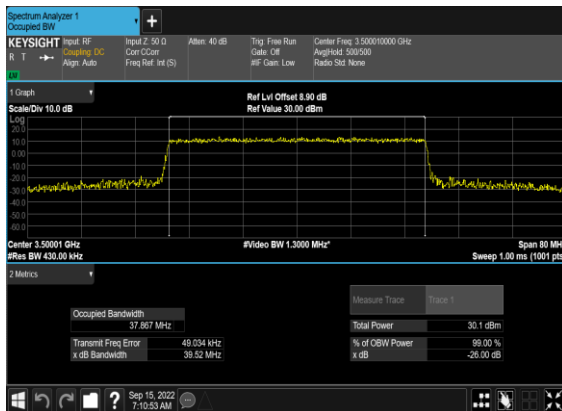

N78(40M)_CP-OFDM_256QAM_Outer_Full_Mid_CH

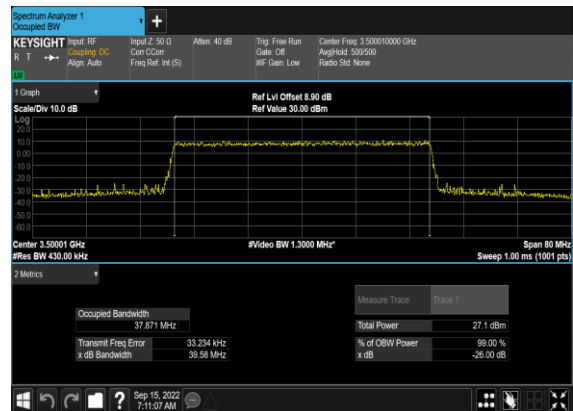

N78(50M)_DFT-s-OFDM_PI_2- BPSK_Outer_Full_Mid_CH

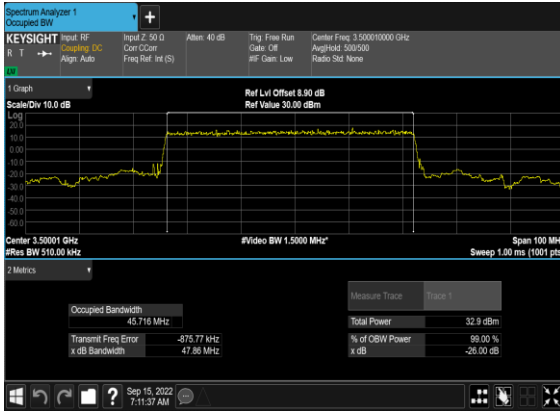

N78(50M)_DFT-s- OFDM_QPSK_Outer_Full_Mid_CH

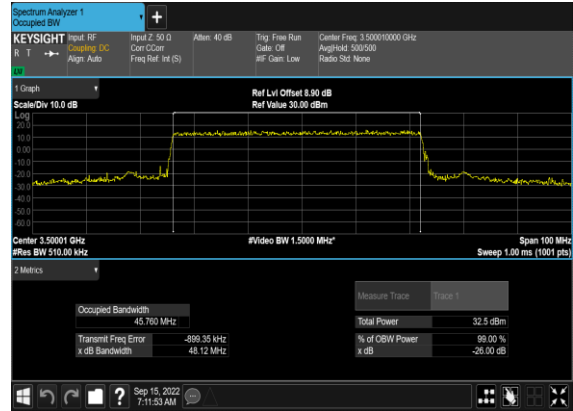

N78(50M)_CP- OFDM_QPSK_Outer_Full_Mid_CH

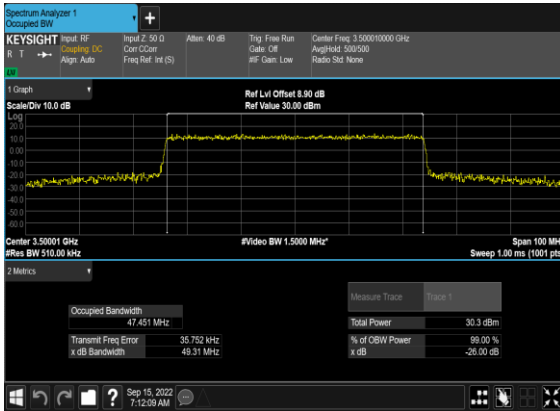

N78(50M)_CP-OFDM_16 QAM_Outer_Full_Mid_CH

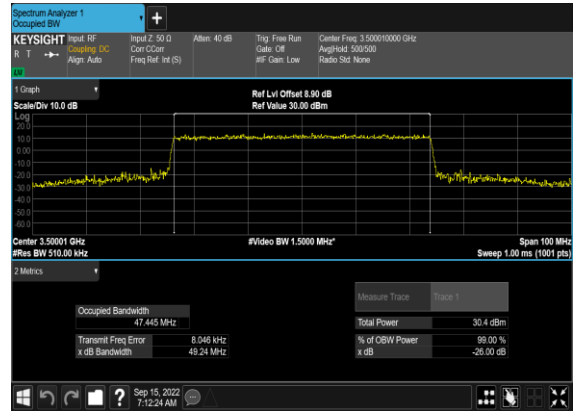

N78(50M)_CP-OFDM_64 QAM_Outer_Full_Mid_CH

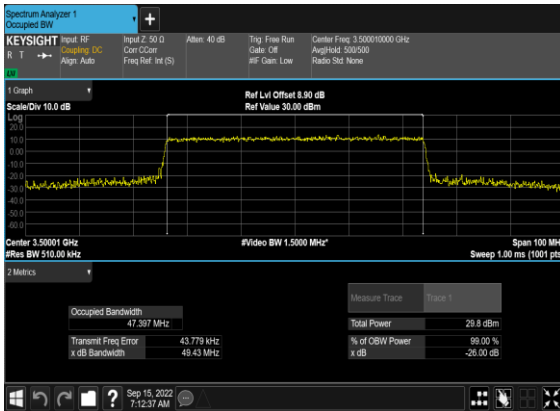

N78(50M)_CP-OFDM_256 QAM_Outer_Full_Mid_CH

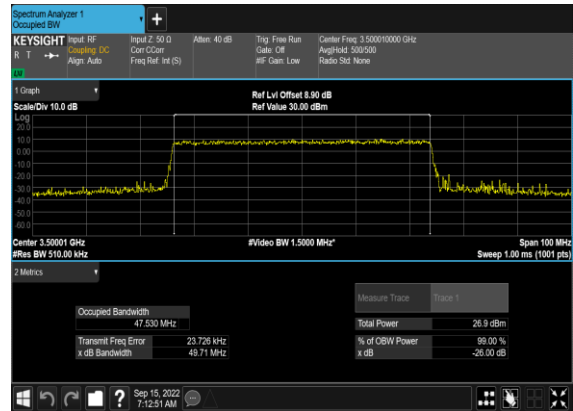

N78(60M)_DFT-s-OFDM_PI_2-
BPSK_Outer_Full_Mid_CH

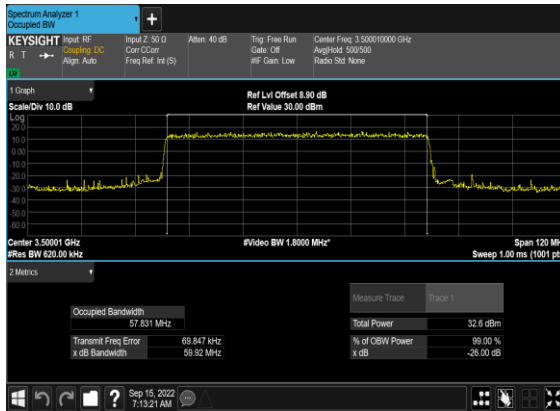

N78(60M)_DFT-s-
OFDM_QPSK_Outer_Full_Mid_CH

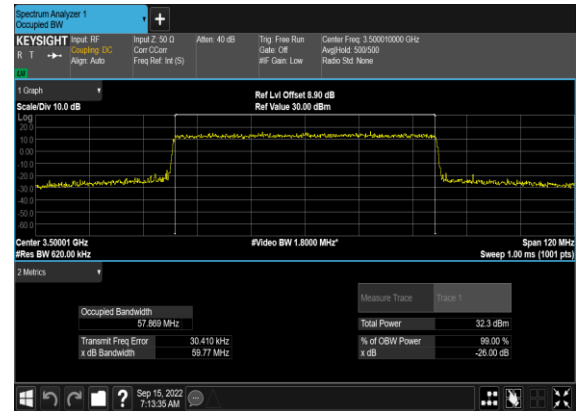

N78(60M)_CP-
OFDM_QPSK_Outer_Full_Mid_CH

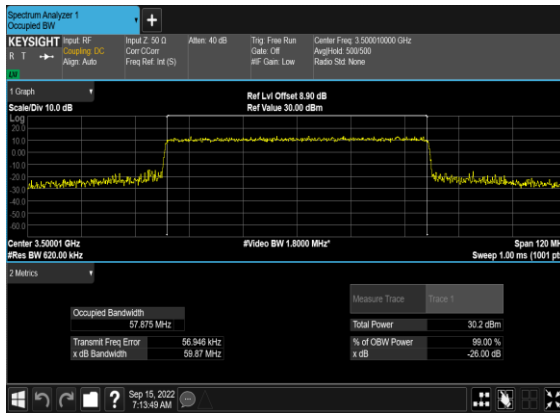

N78(60M)_CP-OFDM_16
QAM_Outer_Full_Mid_CH

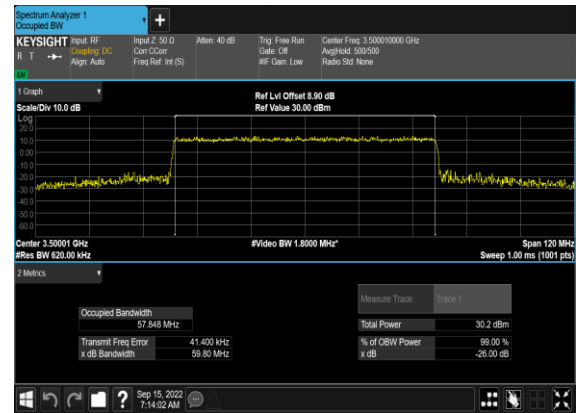

N78(60M)_CP-OFDM_64
QAM_Outer_Full_Mid_CH

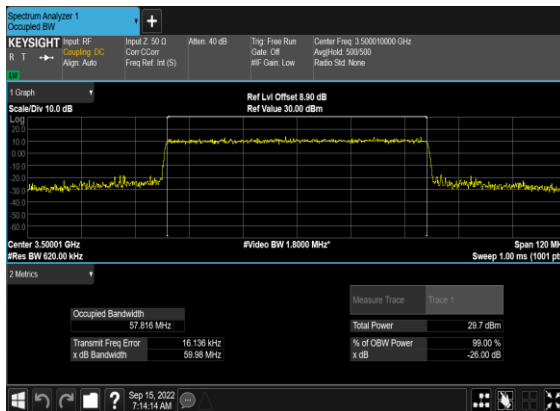

N78(60M)_CP-OFDM_256
QAM_Outer_Full_Mid_CH

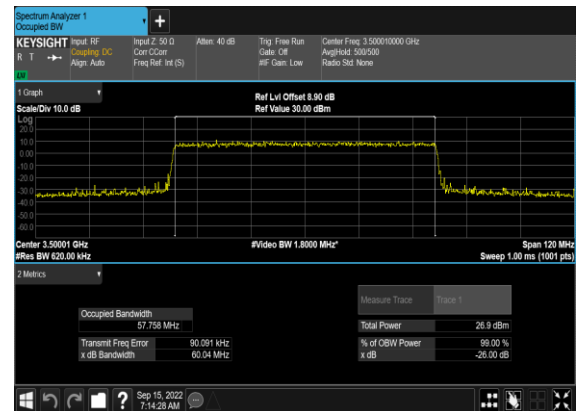

N78(80M)_DFT-s-OFDM_PI_2-BPSK_Outer_Full_Mid_CH

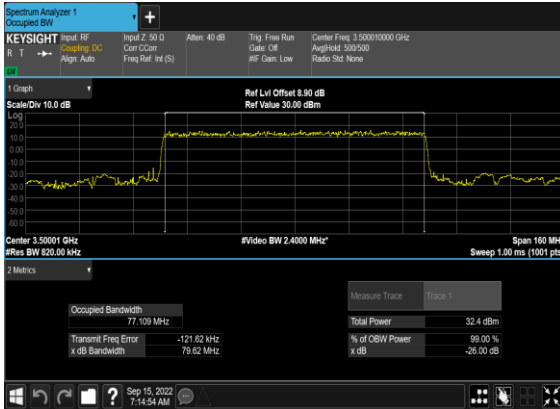

N78(80M)_DFT-s-OFDM_QPSK_Outer_Full_Mid_CH

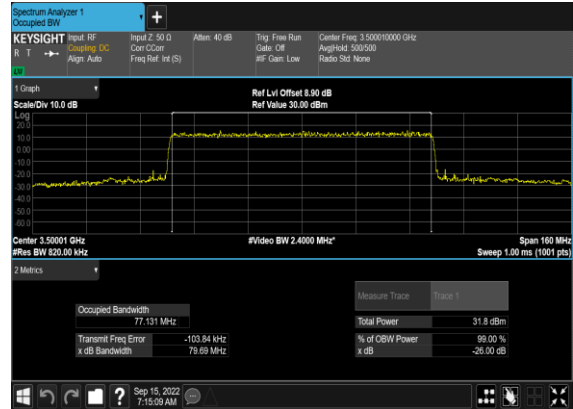

N78(80M)_CP-OFDM_QPSK_Outer_Full_Mid_CH

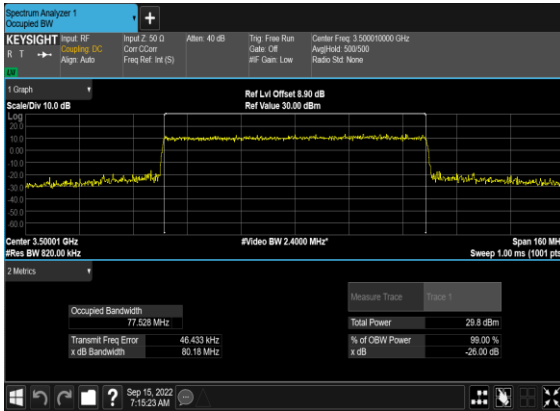

N78(80M)_CP-OFDM_16QAM_Outer_Full_Mid_CH



N78(80M)_CP-OFDM_64QAM_Outer_Full_Mid_CH

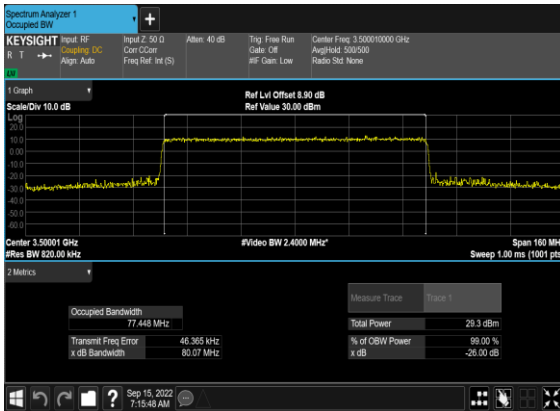

N78(80M)_CP-OFDM_256QAM_Outer_Full_Mid_CH

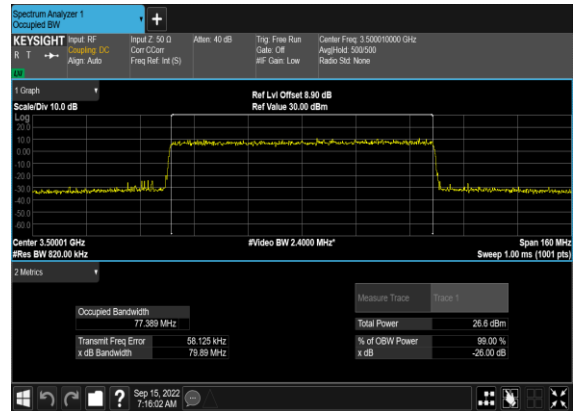

N78(90M)_DFT-s-OFDM_PI_2-BPSK_Outer_Full_Mid_CH

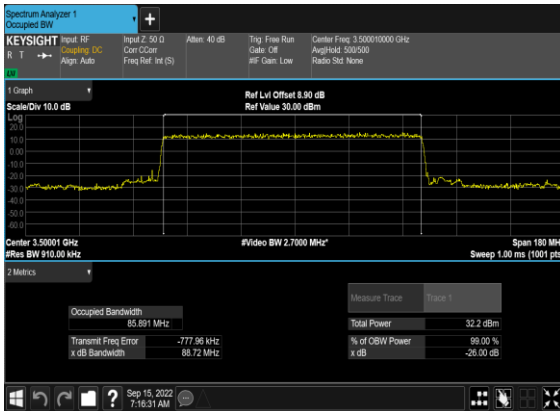

N78(90M)_DFT-s-OFDM_QPSK_Outer_Full_Mid_CH

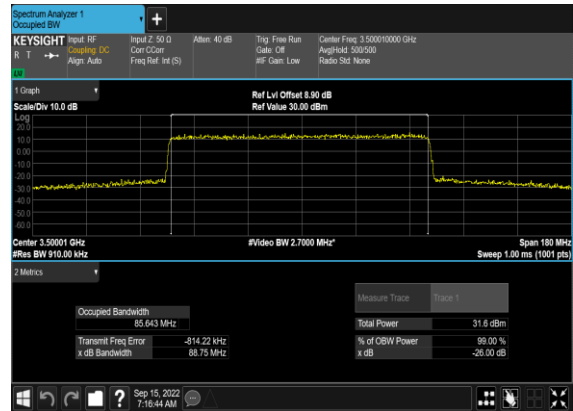

N78(90M)_CP-OFDM_QPSK_Outer_Full_Mid_CH

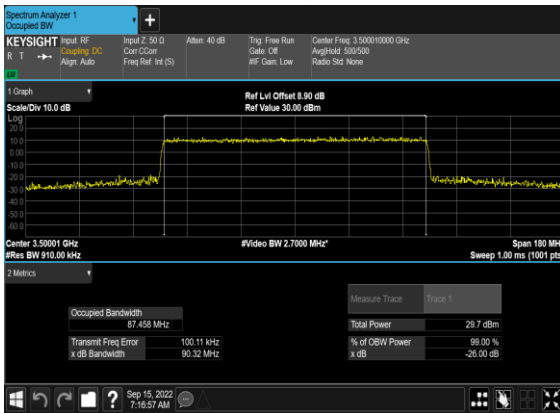

N78(90M)_CP-OFDM_16QAM_Outer_Full_Mid_CH

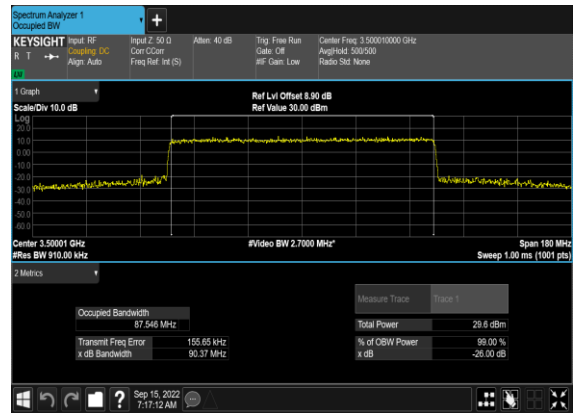

N78(90M)_CP-OFDM_64QAM_Outer_Full_Mid_CH

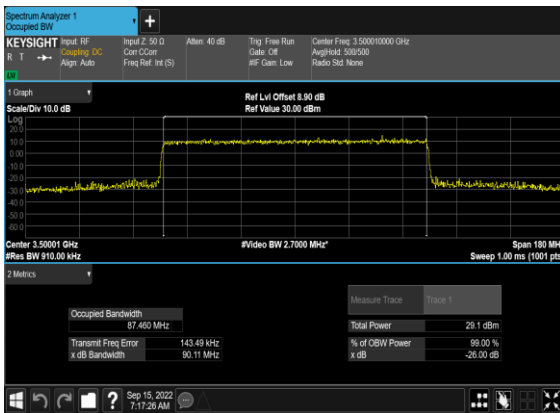

N78(90M)_CP-OFDM_256QAM_Outer_Full_Mid_CH

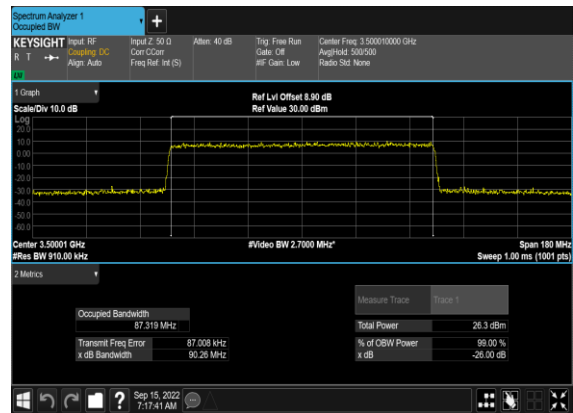

N78(100M)_DFT-s-OFDM_PI_2- BPSK_Outer_Full_Mid_CH

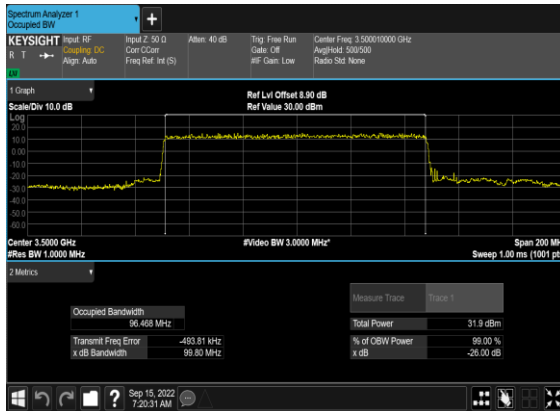

N78(100M)_DFT-s- OFDM_QPSK_Outer_Full_Mid_CH

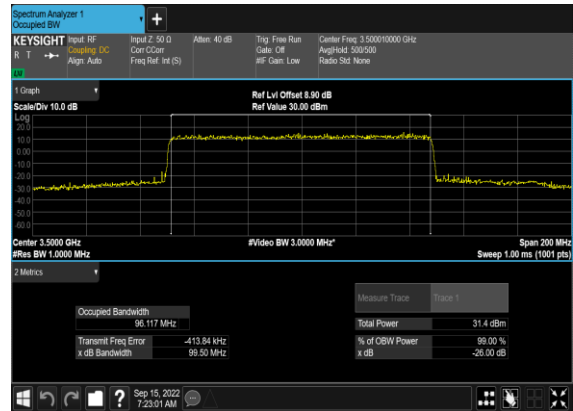

N78(100M)_CP- OFDM_QPSK_Outer_Full_Mid_CH

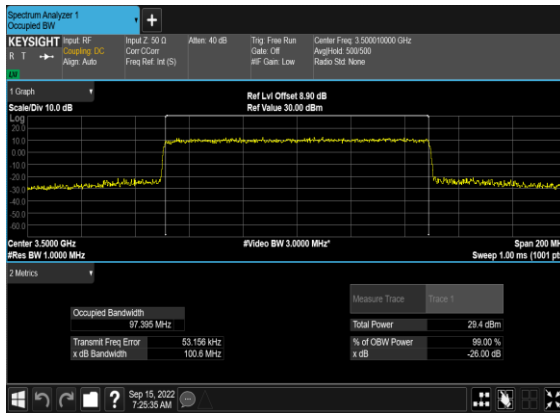

N78(100M)_CP-OFDM_16 QAM_Outer_Full_Mid_CH

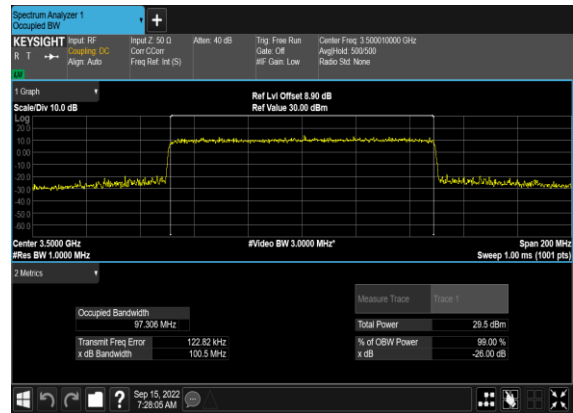

N78(100M)_CP-OFDM_64 QAM_Outer_Full_Mid_CH

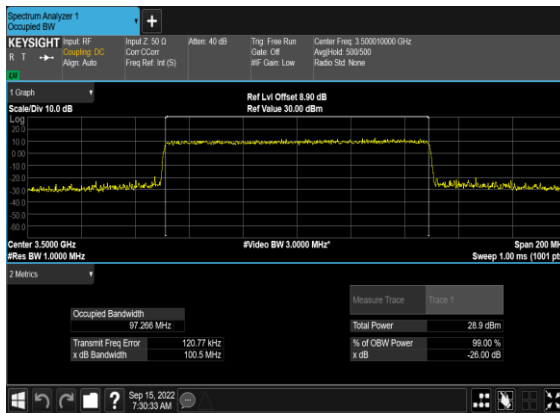

N78(100M)_CP-OFDM_256 QAM_Outer_Full_Mid_CH

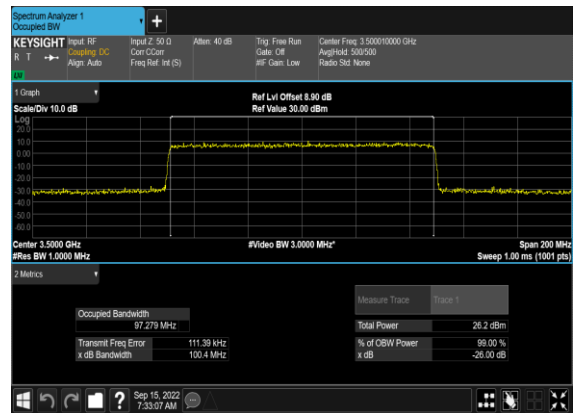

Conducted Spurious Emissions

NR Band	SCS (kHz)	Bandwidth (MHz)	Arfcn	Freq (MHz)	Modulation	RB	Result	Verdict
78	30	20	630668	3460.02	DFT-s-OFDM BPSK	1@0	see graph	---
78	30	20	630668	3460.02	DFT-s-OFDM BPSK	1@0	see graph	PASS
78	30	20	630668	3460.02	DFT-s-OFDM BPSK	1@0	see graph	PASS
78	30	20	630668	3460.02	DFT-s-OFDM QPSK	1@0	see graph	---
78	30	20	630668	3460.02	DFT-s-OFDM QPSK	1@0	see graph	PASS
78	30	20	630668	3460.02	DFT-s-OFDM QPSK	1@0	see graph	PASS
78	30	20	633334	3500.01	DFT-s-OFDM BPSK	1@0	see graph	---
78	30	20	633334	3500.01	DFT-s-OFDM BPSK	1@0	see graph	PASS
78	30	20	633334	3500.01	DFT-s-OFDM BPSK	1@0	see graph	PASS
78	30	20	633334	3500.01	DFT-s-OFDM QPSK	1@0	see graph	---
78	30	20	633334	3500.01	DFT-s-OFDM QPSK	1@0	see graph	PASS
78	30	20	633334	3500.01	DFT-s-OFDM QPSK	1@0	see graph	PASS
78	30	20	636000	3540.0	DFT-s-OFDM BPSK	1@0	see graph	---
78	30	20	636000	3540.0	DFT-s-OFDM BPSK	1@0	see graph	PASS
78	30	20	636000	3540.0	DFT-s-OFDM BPSK	1@0	see graph	PASS
78	30	20	636000	3540.0	DFT-s-OFDM QPSK	1@0	see graph	---
78	30	20	636000	3540.0	DFT-s-OFDM QPSK	1@0	see graph	PASS
78	30	20	636000	3540.0	DFT-s-OFDM QPSK	1@0	see graph	PASS
78	30	50	631668	3475.02	DFT-s-OFDM BPSK	1@0	see graph	---
78	30	50	631668	3475.02	DFT-s-OFDM BPSK	1@0	see graph	PASS
78	30	50	631668	3475.02	DFT-s-OFDM BPSK	1@0	see graph	PASS
78	30	50	631668	3475.02	DFT-s-OFDM QPSK	1@0	see graph	---

78	30	50	631668	3475.02	DFT-s-OFDM QPSK	1@0	see graph	PASS
78	30	50	631668	3475.02	DFT-s-OFDM QPSK	1@0	see graph	PASS
78	30	50	633334	3500.01	DFT-s-OFDM BPSK	1@0	see graph	---
78	30	50	633334	3500.01	DFT-s-OFDM BPSK	1@0	see graph	PASS
78	30	50	633334	3500.01	DFT-s-OFDM BPSK	1@0	see graph	PASS
78	30	50	633334	3500.01	DFT-s-OFDM QPSK	1@0	see graph	---
78	30	50	633334	3500.01	DFT-s-OFDM QPSK	1@0	see graph	PASS
78	30	50	633334	3500.01	DFT-s-OFDM QPSK	1@0	see graph	PASS
78	30	50	635000	3525.0	DFT-s-OFDM BPSK	1@0	see graph	---
78	30	50	635000	3525.0	DFT-s-OFDM BPSK	1@0	see graph	PASS
78	30	50	635000	3525.0	DFT-s-OFDM BPSK	1@0	see graph	PASS
78	30	50	635000	3525.0	DFT-s-OFDM QPSK	1@0	see graph	---
78	30	50	635000	3525.0	DFT-s-OFDM QPSK	1@0	see graph	PASS
78	30	50	635000	3525.0	DFT-s-OFDM QPSK	1@0	see graph	PASS
78	30	100	633334	3500.01	DFT-s-OFDM BPSK	1@0	see graph	---
78	30	100	633334	3500.01	DFT-s-OFDM BPSK	1@0	see graph	PASS
78	30	100	633334	3500.01	DFT-s-OFDM BPSK	1@0	see graph	PASS
78	30	100	633334	3500.01	DFT-s-OFDM QPSK	1@0	see graph	---
78	30	100	633334	3500.01	DFT-s-OFDM QPSK	1@0	see graph	PASS
78	30	100	633334	3500.01	DFT-s-OFDM QPSK	1@0	see graph	PASS

N78(20M)_DFT-s-OFDM_BPSK_Edge_1RB_Left_Low_CH

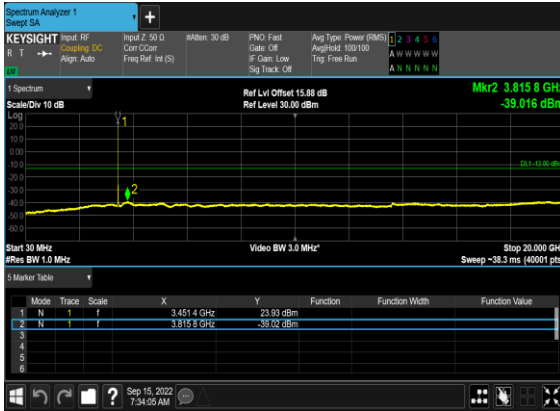

N78(20M)_DFT-s-OFDM_BPSK_Edge_1RB_Left_Low_CH

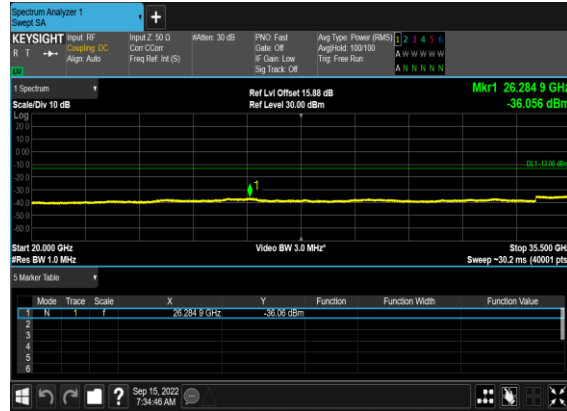

N78(20M)_DFT-s-OFDM_QPSK_Edge_1RB_Left_Low_CH



N78(20M)_DFT-s-OFDM_QPSK_Edge_1RB_Left_Low_CH

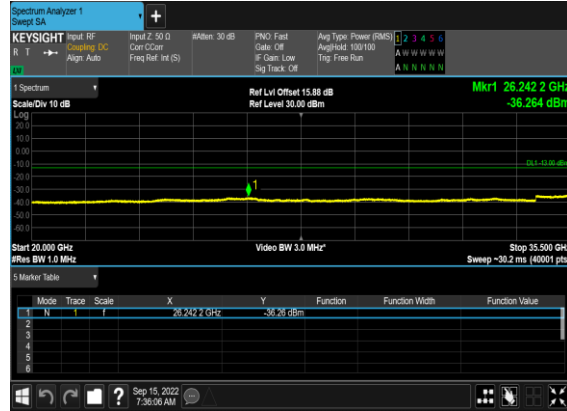

N78(20M)_DFT-s-OFDM_BPSK_Edge_1RB_Left_Mid_CH



N78(20M)_DFT-s-OFDM_BPSK_Edge_1RB_Left_Mid_CH

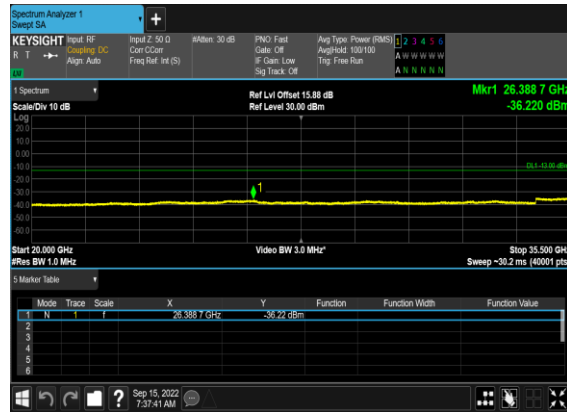

N78(20M)_DFT-s-OFDM_QPSK_Edge_1RB_Left_Mid_CH

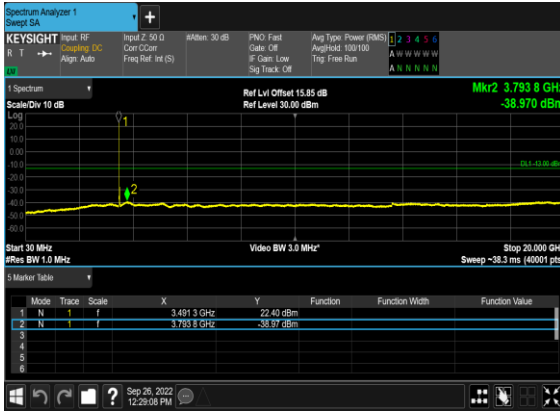

N78(20M)_DFT-s-OFDM_QPSK_Edge_1RB_Left_Mid_CH

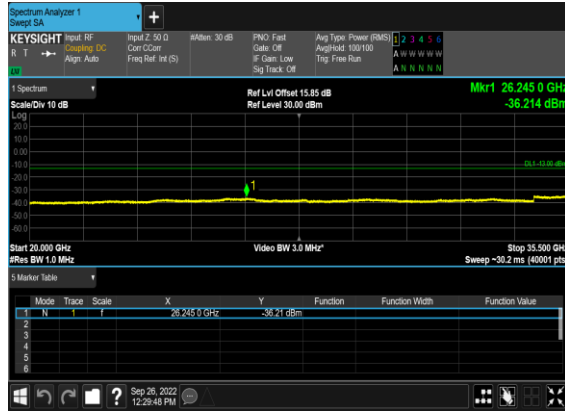

N78(20M)_DFT-s-OFDM_BPSK_Edge_1RB_Left_High_CH

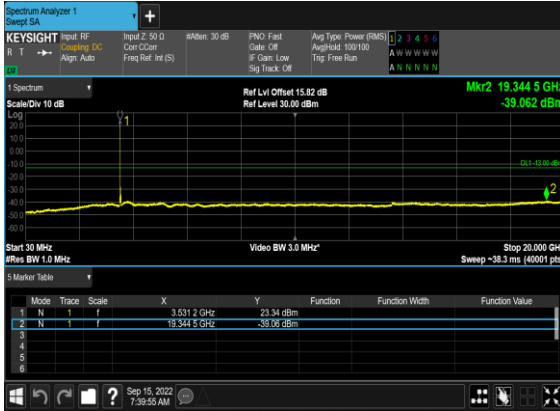

N78(20M)_DFT-s-OFDM_BPSK_Edge_1RB_Left_High_CH

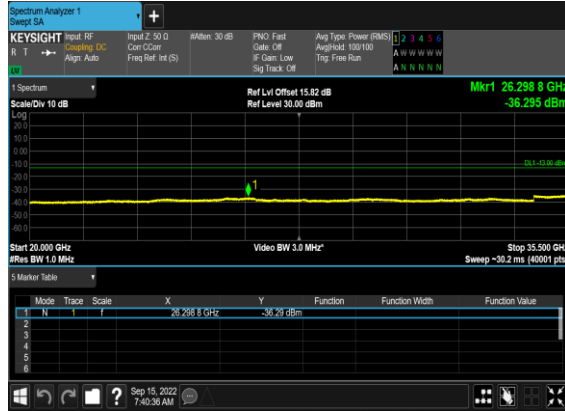

N78(20M)_DFT-s-OFDM_QPSK_Edge_1RB_Left_High_CH

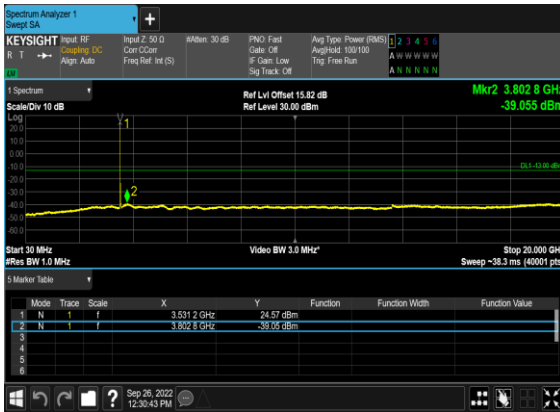

N78(20M)_DFT-s-OFDM_QPSK_Edge_1RB_Left_High_CH

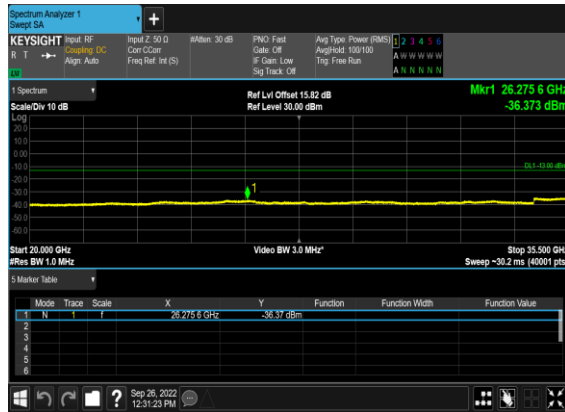

N78(50M)_DFT-s-OFDM_BPSK_Edge_1RB_Left_Low_CH

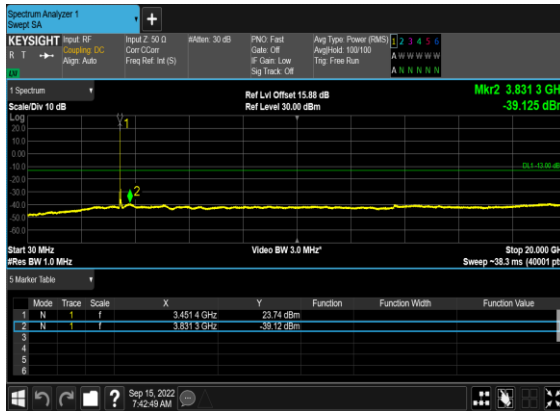

N78(50M)_DFT-s-OFDM_BPSK_Edge_1RB_Left_Low_CH

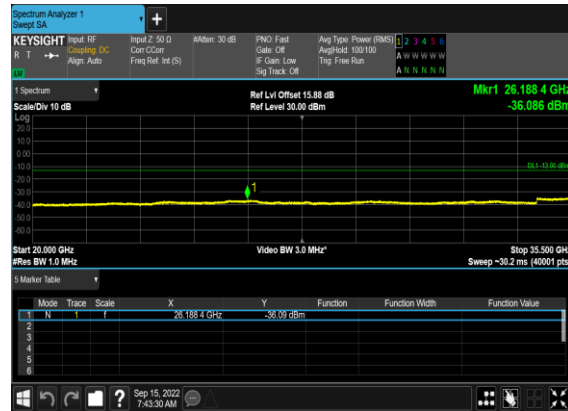

N78(50M)_DFT-s-OFDM_QPSK_Edge_1RB_Left_Low_CH

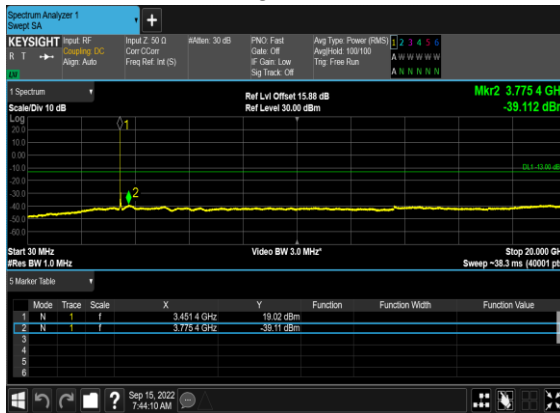

N78(50M)_DFT-s-OFDM_QPSK_Edge_1RB_Left_Low_CH

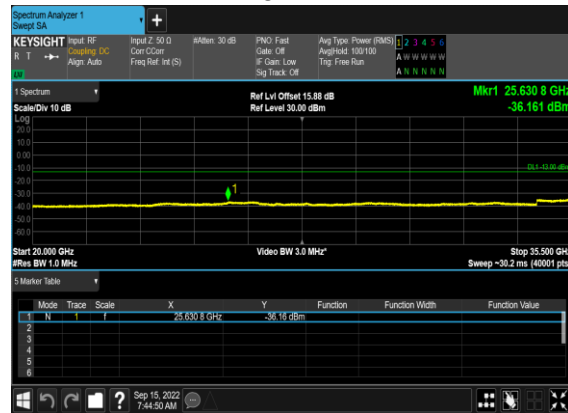

N78(50M)_DFT-s-OFDM_BPSK_Edge_1RB_Left_Mid_CH

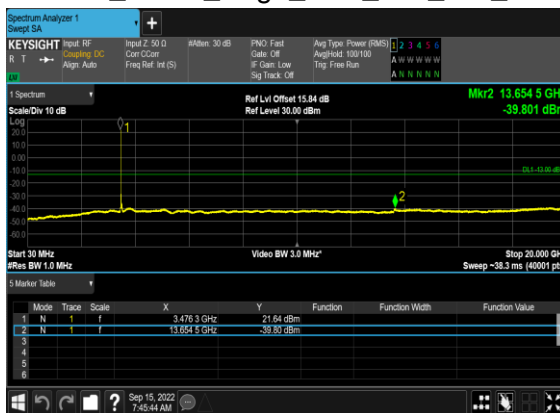

N78(50M)_DFT-s-OFDM_BPSK_Edge_1RB_Left_Mid_CH

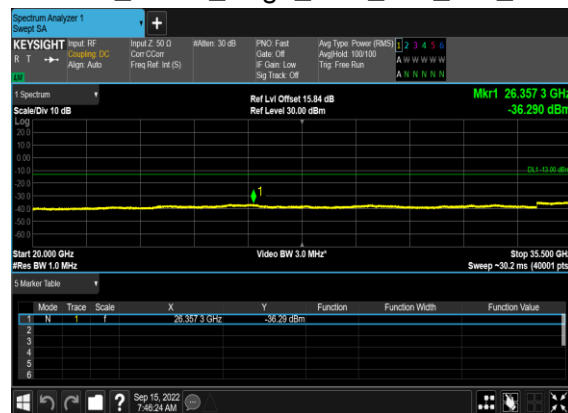

N78(50M)_DFT-s-OFDM_QPSK_Edge_1RB_Left_Mid_CH

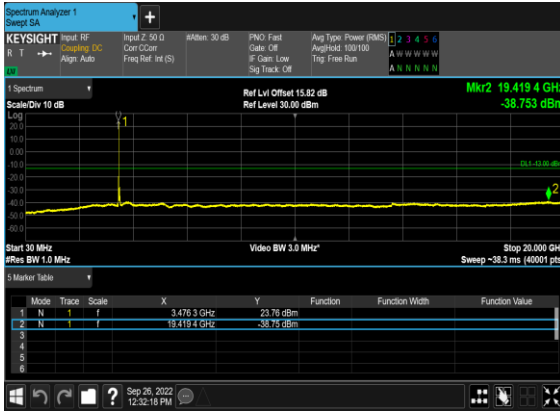

N78(50M)_DFT-s-OFDM_QPSK_Edge_1RB_Left_Mid_CH

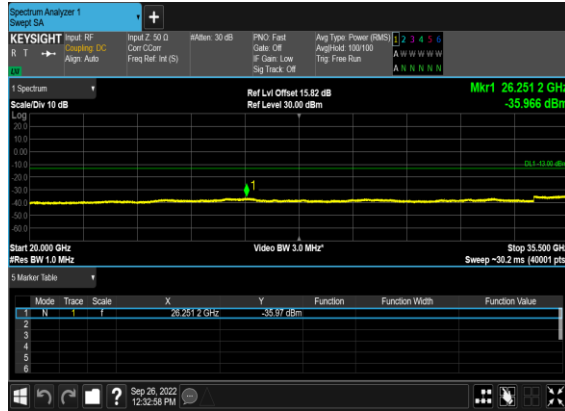

N78(50M)_DFT-s-OFDM_BPSK_Edge_1RB_Left_High_CH

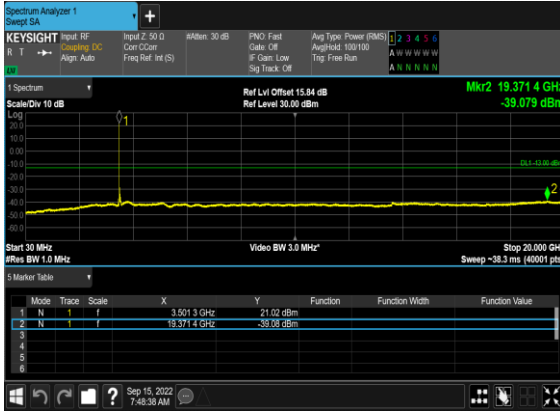

N78(50M)_DFT-s-OFDM_BPSK_Edge_1RB_Left_High_CH

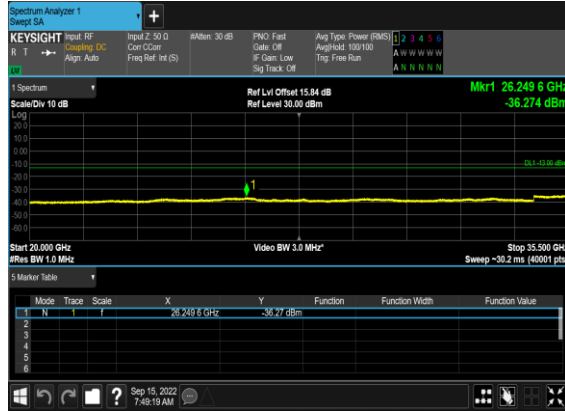

N78(50M)_DFT-s-OFDM_QPSK_Edge_1RB_Left_High_CH



N78(50M)_DFT-s-OFDM_QPSK_Edge_1RB_Left_High_CH

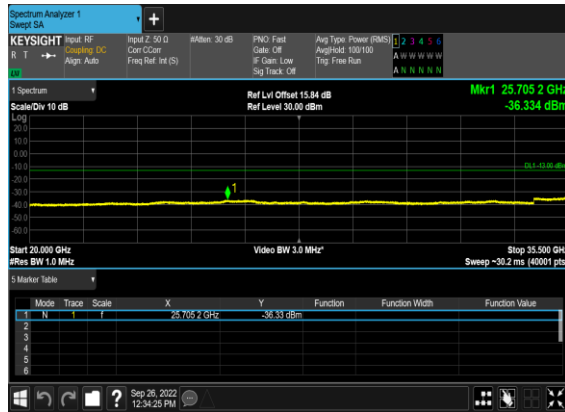

N78(100M)_DFT-s-OFDM_BPSK_Edge_1RB_Left_Mid_CH

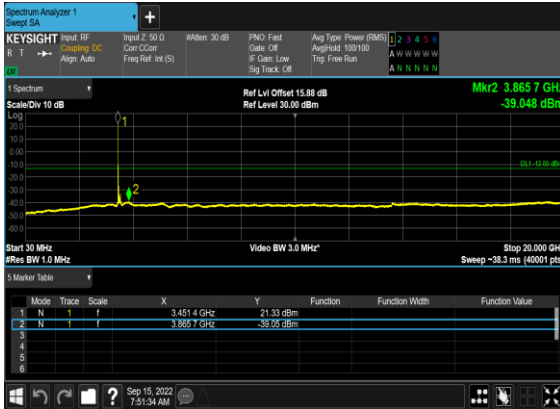

N78(100M)_DFT-s-OFDM_BPSK_Edge_1RB_Left_Mid_CH

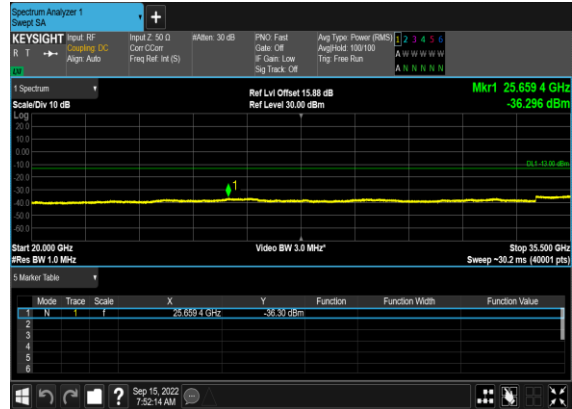

N78(100M)_DFT-s-OFDM_QPSK_Edge_1RB_Left_Mid_CH

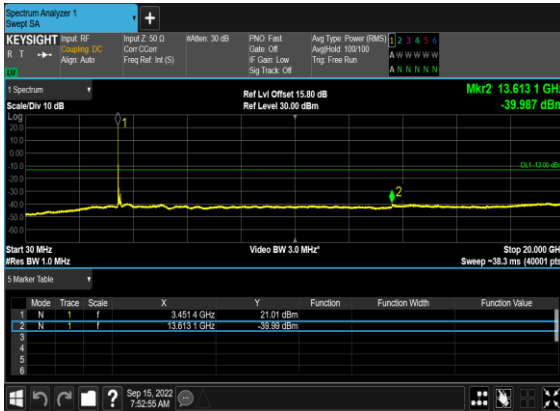

N78(100M)_DFT-s-OFDM_QPSK_Edge_1RB_Left_Mid_CH

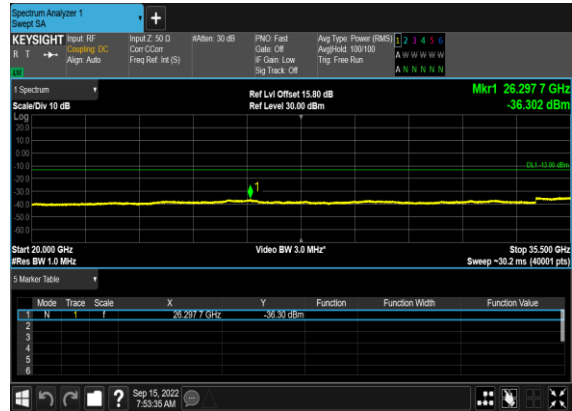

Conducted Band Edge

NR Band	SCS (kHz)	Bandwidth (MHz)	Arfcn	Freq (MHz)	Modulation	RB	Result	Verdict
78	30	20	630668	3460.02	DFT-s-OFDM BPSK	1@0	see graph	PASS
78	30	20	630668	3460.02	DFT-s-OFDM QPSK	1@0	see graph	PASS
78	30	20	630668	3460.02	DFT-s-OFDM BPSK	50@0	see graph	PASS
78	30	20	630668	3460.02	DFT-s-OFDM QPSK	50@0	see graph	PASS
78	30	20	636000	3540.0	DFT-s-OFDM BPSK	1@50	see graph	PASS
78	30	20	636000	3540.0	DFT-s-OFDM QPSK	1@50	see graph	PASS
78	30	20	636000	3540.0	DFT-s-OFDM BPSK	50@0	see graph	PASS
78	30	20	636000	3540.0	DFT-s-OFDM QPSK	50@0	see graph	PASS
78	30	50	631668	3475.02	DFT-s-OFDM BPSK	1@0	see graph	PASS
78	30	50	631668	3475.02	DFT-s-OFDM QPSK	1@0	see graph	PASS
78	30	50	631668	3475.02	DFT-s-OFDM BPSK	128@0	see graph	PASS
78	30	50	631668	3475.02	DFT-s-OFDM QPSK	128@0	see graph	PASS
78	30	50	635000	3525.0	DFT-s-OFDM BPSK	1@132	see graph	PASS
78	30	50	635000	3525.0	DFT-s-OFDM QPSK	1@132	see graph	PASS
78	30	50	635000	3525.0	DFT-s-OFDM BPSK	128@0	see graph	PASS
78	30	50	635000	3525.0	DFT-s-OFDM QPSK	128@0	see graph	PASS
78	30	100	633334	3500.01	DFT-s-OFDM BPSK	1@0	see graph	PASS
78	30	100	633334	3500.01	DFT-s-OFDM QPSK	1@0	see graph	PASS
78	30	100	633334	3500.01	DFT-s-OFDM BPSK	1@272	see graph	PASS
78	30	100	633334	3500.01	DFT-s-OFDM QPSK	1@272	see graph	PASS
78	30	100	633334	3500.01	DFT-s-OFDM BPSK	270@0	see graph	PASS
78	30	100	633334	3500.01	DFT-s-OFDM QPSK	270@0	see graph	PASS