



# FCC RF Test Report

**APPLICANT** : Xiaomi Communications Co., Ltd.  
**EQUIPMENT** : Mobile Phone  
**BRAND NAME** : Xiaomi  
**MODEL NAME** : 2201122G  
**FCC ID** : 2AFZZ122G  
**STANDARD** : 47 CFR Part 2, 96  
**CLASSIFICATION** : Citizens Band End User Devices (CBE)  
**EQUIPMENT TYPE** : End User Equipment  
**TEST DATE(S)** : Nov. 22, 2021 ~ Dec. 16, 2021

We, Sporton International (Kunshan) Inc., would like to declare that the tested sample has been evaluated in accordance with the procedures given in ANSI C63.26 and shown compliance with the applicable technical standards.

The test results in this report apply exclusively to the tested model / sample. Without written approval of Sporton International (Kunshan) Inc., the test report shall not be reproduced except in full.

Reviewed by: Jason Jia / Supervisor

Approved by: Alex Wang / Manager



**Sporton International (Kunshan) Inc.**

**No. 1098, Pengxi North Road, Kunshan Economic Development Zone Jiangsu Province 215300  
People's Republic of China**



# Table of Contents

History of this test report..... 3

Summary of Test Result..... 4

**1 General Description ..... 5**

    1.1 Applicant..... 5

    1.2 Manufacturer ..... 5

    1.3 Feature of Equipment Under Test..... 5

    1.4 Maximum EIRP Power and Emission Designator ..... 6

    1.5 Testing Site..... 6

    1.6 Test Software ..... 6

    1.7 Applied Standards ..... 7

**2 Test Configuration of Equipment Under Test ..... 8**

    2.1 Test Mode..... 8

    2.2 Connection Diagram of Test System ..... 9

    2.3 Support Unit used in test configuration ..... 9

    2.4 Measurement Results Explanation Example ..... 9

    2.5 Frequency List of Low/Middle/High Channels..... 10

**3 Conducted Test Items..... 11**

    3.1 Measuring Instruments..... 11

    3.2 Conducted Output Power ..... 12

    3.3 EIRP ..... 13

    3.4 Occupied Bandwidth ..... 14

    3.5 Conducted Band Edge ..... 15

    3.6 Conducted Spurious Emission ..... 16

    3.7 Frequency Stability..... 17

**4 Radiated Test Items ..... 18**

    4.1 Measuring Instruments..... 18

    4.2 Test Setup ..... 18

    4.3 Test Result of Radiated Test..... 19

    4.4 Radiated Spurious Emission ..... 20

**5 List of Measuring Equipment..... 21**

**6 Uncertainty of Evaluation ..... 22**

**Appendix A. Test Results of Conducted Test**

**Appendix B. Test Results of EIRP and Radiated Test**

**Appendix C. Test Setup Photographs**



### History of this test report

Report No.	Version	Description	Issued Date
FG101701D	01	Initial issue of report	Dec. 21, 2021



### Summary of Test Result

Report Clause	Ref Std. Clause	Test Items	Result (PASS/FAIL)	Remark
3.2	§2.1046	Conducted Output Power	Reporting only	-
-	§96.41	Peak-to-Average Ratio	Not Required	Not applicable for End User Devices
3.3	§96.41	Maximum E.I.R.P	Pass	-
		Maximum Power Spectral Density	Pass	Not applicable for End User Devices
3.4	§2.1049 §96.41	Occupied Bandwidth	Reporting only	-
3.5	§2.1051 §96.41	Conducted Band Edge Measurement Adjacent Channel Leakage Ratio	Pass	-
3.6	§2.1051 §96.41	Conducted Spurious Emission	Pass	
3.7	§2.1055	Frequency Stability for Temperature & Voltage	Pass	-
4.4	§2.1051 §96.41	Radiated Spurious Emission	Pass	Under limit 14.67 dB at 10848.000 MHz

**Declaration of Conformity:**

The test results with all measurement uncertainty excluded are presented in accordance with the regulation limits or requirements declared by manufacturers.

**Comments and Explanations:**

The declared of product specification for EUT presented in the report are provided by the manufacturer, and the manufacturer takes all the responsibilities for the accuracy of product specification.



# 1 General Description

## 1.1 Applicant

Xiaomi Communications Co., Ltd.

#019, 9th Floor, Building 6, 33 Xi'erqi Middle Road, Haidian District, Beijing, China, 100085

## 1.2 Manufacturer

Xiaomi Communications Co., Ltd.

#019, 9th Floor, Building 6, 33 Xi'erqi Middle Road, Haidian District, Beijing, China, 100085

## 1.3 Feature of Equipment Under Test

Product Feature	
Equipment	Mobile Phone
Brand Name	Xiaomi
Model Name	2201122G
FCC ID	2AFZZ122G
Tx Frequency	LTE Band 48: 3550 MHz ~ 3700 MHz
Rx Frequency	LTE Band 48: 3550 MHz ~ 3700 MHz
Bandwidth	5MHz / 10MHz / 15MHz / 20MHz
Maximum Output Power to Antenna	<Ant. 10> : 22.75 dBm
Antenna Gain	<Ant. 10> : LTE Band 48 : -3.0 dBi
Type of Modulation	QPSK / 16QAM / 64QAM / 256QAM
IMEI Code	Conducted: 863690050059314/863690050059322 Radiation: 863690050059678/863690050059686
HW Version	P2.1
SW Version	MIUI 13
EUT Stage	Identical Prototype

**Remark:**

1. The above EUT's information was declared by manufacturer. Please refer to the specifications or user's manual for more detailed description.
2. The EIRP is calculated from Output power and antenna gain, so the maximum EIRP is shown in the report, LTE Band 48 for Antenna 10.

### 1.4 Maximum EIRP Power and Emission Designator

LTE Band 48		QPSK		16QAM/64QAM/256QAM	
BW (MHz)	Frequency Range (MHz)	Maximum EIRP(W)	Emission Designator (99%OBW)	Maximum EIRP(W)	Emission Designator (99%OBW)
5	3552.5 ~ 3697.5	0.0839	4M45G7D	0.0701	4M50W7D
10	3555.0 ~ 3695.0	0.0851	9M07G7D	0.0698	9M09W7D
15	3557.5 ~ 3692.5	0.0944	13M5G7D	0.0771	13M5W7D
20	3560.0 ~ 3690.0	0.0940	17M9G7D	0.0782	17M9W7D

**Note:**

1. Based on engineering evaluation, only the worst modulation test results are shown in the report.
2. All modulations have been tested, and only the worst test results of PSK & QAM are shown in the report.
3. Manufacturer declares that LTE Band 48 channels shall be set NS\_27 to reduce the conducted power.

### 1.5 Testing Site

Sporton International (Kunshan) Inc. is accredited to ISO/IEC 17025:2017 by American Association for Laboratory Accreditation with Certificate Number 5145.02.

<b>Test Firm</b>	Sporton International (Kunshan) Inc.		
<b>Test Site Location</b>	No. 1098, Pengxi North Road, Kunshan Economic Development Zone Jiangsu Province 215300 People's Republic of China TEL : +86-512-57900158 FAX : +86-512-57900958		
<b>Test Site No.</b>	<b>Sporton Site No.</b>	<b>FCC Designation No.</b>	<b>FCC Test Firm Registration No.</b>
	03CH04-KS TH01-KS	CN1257	314309

### 1.6 Test Software

Item	Site	Manufacturer	Name	Version
1.	03CH04-KS	AUDIX	E3	6.2009-8-24a



## 1.7 Applied Standards

According to the specifications of the manufacturer, the EUT must comply with the requirements of the following standards:

- ♦ ANSI C63.26-2015
- ♦ ANSI / TIA-603-E
- ♦ 47 CFR Part 2, 96
- ♦ FCC KDB 971168 D01 Power Meas. License Digital Systems v03r01
- ♦ FCC KDB 940660 D01 Part 96 CBRS v03
- ♦ FCC KDB 412172 D01 Determining ERP and EIRP v01r01

**Remark:**

1. All test items were verified and recorded according to the standards and without any deviation during the test.
2. This EUT has also been tested and complied with the requirements of FCC Part 15, Subpart B, recorded in a separate test report.



## 2 Test Configuration of Equipment Under Test

### 2.1 Test Mode

Antenna port conducted and radiated test items listed below are performed according to KDB 971168 D01 Power Meas. License Digital Systems v03r01 with maximum output power.

For radiated measurement, pre-scanned in three orthogonal panels, X, Y, Z. The worst cases (Y plane) were recorded in this report.

Test Items	Band	Bandwidth (MHz)						Modulation				RB #			Test Channel		
		1.4	3	5	10	15	20	QPSK	16QAM	64QAM	256QAM	1	Half	Full	L	M	H
Max. Output Power	48	-	-	v	v	v	v	v	v	v	v	v	v	v	v	v	v
26dB and 99% Bandwidth	48	-	-	v	v	v	v	v	v	v	v			v		v	
Conducted Band Edge	48	-	-	v	v	v	v	v	v	v	v	v	v	v	v	v	v
Conducted Spurious Emission	48	-	-	v	v	v	v	v				v			v	v	v
E.R.P / E.I.R.P	48	-	-	v	v	v	v	v	v	v	v	v	v	v	v	v	v
Frequency Stability	48	-	-		v			v				v				v	
Radiated Spurious Emission	48	Worst Case														v	
Remark	<ol style="list-style-type: none"> <li>The mark "v" means that this configuration is chosen for testing</li> <li>The mark "-" means that this bandwidth is not supported.</li> <li>The device is investigated from 30MHz to 10 times of fundamental signal for radiated spurious emission test under different RB size/offset and modulations in exploratory test. Subsequently, only the worst case emissions are reported.</li> <li>All the radiated test cases were performed with Adapter and USB Cable 1.</li> </ol>																



## 2.2 Connection Diagram of Test System

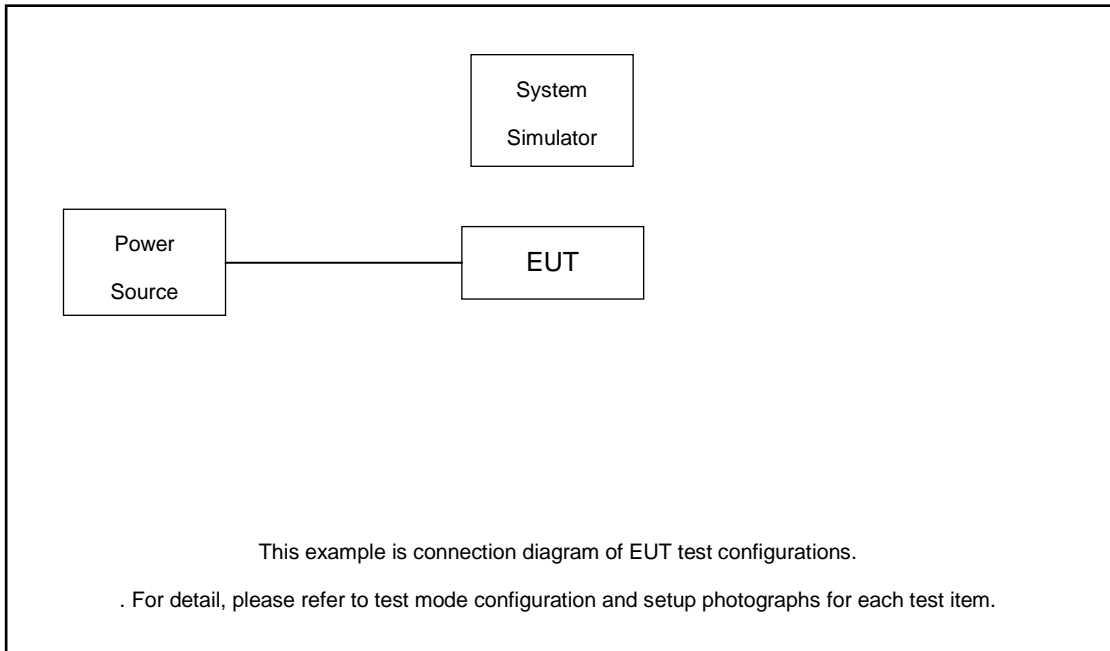

## 2.3 Support Unit used in test configuration

Item	Equipment	Trade Name	Model No.	FCC ID	Data Cable	Power Cord
1.	Power Supply	GWINSTEK	PSS-2002	N/A	N/A	Unshielded, 1.8 m
2.	LTE Base Station	Anritsu	MT8820C	Fcc DoC	N/A	Unshielded, 1.8 m

## 2.4 Measurement Results Explanation Example

### For all conducted test items:

The offset level is set in the spectrum analyzer to compensate the RF cable loss and attenuator factor between EUT conducted output port and spectrum analyzer. With the offset compensation, the spectrum analyzer reading level is exactly the EUT RF output level.

The spectrum analyzer offset is derived from RF cable loss and attenuator factor.

*Offset = RF cable loss.*

Following shows an offset computation example with cable loss 8.72 dB.

Example :

$$\begin{aligned} \text{Offset(dB)} &= \text{RF cable loss(dB)}. \\ &= 8.72 \text{ (dB)} \end{aligned}$$



## 2.5 Frequency List of Low/Middle/High Channels

LTE Band 48 Channel and Frequency List				
BW [MHz]	Channel/Frequency(MHz)	Lowest	Middle	Highest
20	Channel	55340	55990	56640
	Frequency	3560.0	3625.0	3690.0
15	Channel	55315	55990	56665
	Frequency	3557.5	3625.0	3692.5
10	Channel	55290	55990	56690
	Frequency	3555.0	3625.0	3695.0
5	Channel	55265	55990	56715
	Frequency	3552.5	3625.0	3697.5

### 3 Conducted Test Items

#### 3.1 Measuring Instruments

See list of measuring instruments of this test report.

##### 3.1.1 Test Setup

##### 3.1.2 Conducted Output Power



##### 3.1.3 PSD, Peak-to-Average Ratio, Occupied Bandwidth, Conducted Band-Edge and Conducted Spurious Emission



##### 3.1.4 Frequency Stability

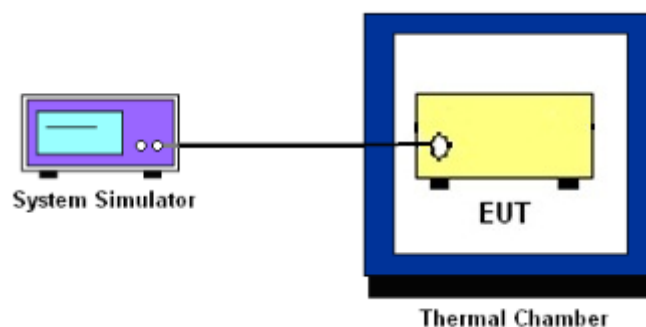

##### 3.1.5 Test Result of Conducted Test

Please refer to Appendix A.



## **3.2 Conducted Output Power**

### **3.2.1 Description of the Conducted Output Power Measurement**

A system simulator was used to establish communication with the EUT. Its parameters were set to force the EUT transmitting at maximum output power. The measured power in the radio frequency on the transmitter output terminals shall be reported.

### **3.2.2 Test Procedures**

1. The transmitter output port was connected to the system simulator.
2. Set EUT at maximum power through the system simulator.
3. Select lowest, middle, and highest channels for each band and different modulation.
4. Measure and record the power level from the system simulator.

### 3.3 EIRP

#### 3.3.1 Description of the EIRP Measurement

EIRP limits for CBRS equipment as below table:

Device		Maximum EIRP (dBm/10 MHz)	Maximum PSD (dBm/MHz)
Applied	End User Device	23	n/a
	Category A CBSD	30	20
	Category B CBSD	47	37

**Remark:** The worst case EIRP shown in this section is found with LTE operating only using 1RB. As such, the EIRP/10MHz and full channel EIRP values will be identical since 1RB is fully contained within all available channel bandwidths for LTE Band 48 (i.e. 5, 10, 15, 20MHz)

#### 3.3.2 Test Procedures for EIRP

1. Establishing a communications link with the call box (Base station) to measure the Maximum conducted power, the parameters were set to force the EUT transmitting at maximum output power level. Use the average power measurement function to measure total channel power of each channel bandwidth (per ANSI C63.26-2015 Section 5.2.1)
2. Determining ERP and/or EIRP from conducted RF output power measurements (Per ANSI C63.26-2015 Section 5.2.5.5)
  - EIRP =  $P_T + G_T - L_C$ , ERP = EIRP - 2.15, where
  - $P_T$  = transmitter output power in dBm
  - $G_T$  = gain of the transmitting antenna in dBi
  - $L_C$  = signal attenuation in the connecting cable between the transmitter and antenna in dB



### 3.4 Occupied Bandwidth

#### 3.4.1 Description of Occupied Bandwidth Measurement

The occupied bandwidth is the width of a frequency band such that, below the lower and above the upper frequency limits, the mean powers emitted are each equal to a specified percentage 0.5% of the total mean transmitted power.

The 26 dB emission bandwidth is defined as the frequency range between two points, one above and one below the carrier frequency, at which the spectral density of the emission is attenuated 26 dB below the maximum in-band spectral density of the modulated signal. Spectral density (power per unit bandwidth) is to be measured with a detector of resolution bandwidth equal to approximately 1.0% of the emission bandwidth.

#### 3.4.2 Test Procedures

The testing follows ANSI C63.26-2015 Section 5.4.3 (26dB) and Section 5.4.4 (99OB)

1. The EUT was connected to spectrum analyzer and system simulator via a power divider.
2. The spectrum analyzer center frequency is set to the nominal EUT channel center frequency. The span range for the spectrum analyzer shall be between two and five times the anticipated OBW.
3. The nominal resolution bandwidth (RBW) shall be in the range of 1 to 5 % of the anticipated OBW, and the VBW shall be at least 3 times the RBW.
4. Set the detection mode to peak, and the trace mode to max hold.
5. Determine the reference value: Set the EUT to transmit a modulated signal. Allow the trace to stabilize. Set the spectrum analyzer marker to the highest level of the displayed trace.  
(this is the reference value)
6. Determine the “-26 dB down amplitude” as equal to (Reference Value – X).
7. Place two markers, one at the lowest and the other at the highest frequency of the envelope of the spectral display such that each marker is at or slightly below the “-X dB down amplitude” determined in step 6. If a marker is below this “-X dB down amplitude” value it shall be placed as close as possible to this value. The OBW is the positive frequency difference between the two markers.
8. Use the 99 % power bandwidth function of the spectrum analyzer and report the measured bandwidth.

## 3.5 Conducted Band Edge

### 3.5.1 Description of Conducted Band Edge Measurement

Part 96.41 (e) (1) (i)

For CBSD the emission limits outside the fundamental are as follows:

Within 0 MHz to 10 MHz above and below the assigned channel  $\leq -13$  dBm/MHz

Greater than 10 MHz above and below the assigned channel  $\leq -25$  dBm/MHz

Part 96.41 (e) (1) (ii)

For End User Devices the emission limits outside the fundamental are as follows:

Within 0 MHz to B MHz above and below the assigned channel  $\leq -13$  dBm/MHz

Greater than B MHz above and below the assigned channel  $\leq -25$  dBm/MHz

where B is the bandwidth in megahertz of the assigned channel or multiple contiguous channels of the End User Device.

Notwithstanding the emission limits in this paragraph, the Adjacent Channel Leakage Ratio for End User Devices shall be at least 30 dB.

Part 96.41 (e) (2)

For CBSDs and End User Devices, the conducted power of emissions below 3540 MHz or above 3710 MHz shall not exceed  $-25$  dBm/MHz, and the conducted power of emissions below 3530 MHz or above 3720 MHz shall not exceed  $-40$  dBm/MHz

### 3.5.2 Test Procedures

The testing follows FCC KDB 971168 D01 v03r01 Section 6.1.

1. The EUT was connected to spectrum analyzer and system simulator via a power divider.
2. The band edges of low and high channels for the highest RF powers were measured.
3. Set RBW  $\geq 1\%$  EBW in the 1MHz band immediately outside and adjacent to the band edge.
4. Beyond the 1 MHz band from the band edge, RBW=1MHz was used
5. Offset has included the duty factor for LTE Band 48. Duty factor  $=10 \log (1/x)$ , where x is the measured duty cycle.
6. Set spectrum analyzer with RMS detector.
7. The RF fundamental frequency should be excluded against the limit line in the operating frequency band.



## 3.6 Conducted Spurious Emission

### 3.6.1 Description of Conducted Spurious Emission Measurement

96.41 (e)(2)

The conducted power of any emissions below 3530 MHz or above 3720 MHz shall not exceed -40dBm/MHz.

### 3.6.2 Test Procedures

The testing follows FCC KDB 971168 D01 v03r01 Section 6.1.

1. The EUT was connected to spectrum analyzer and system simulator via a power divider.
2. The RF output of EUT was connected to the spectrum analyzer by RF cable and attenuator. The path loss was compensated to the results for each measurement.
3. The middle channel for the highest RF power within the transmitting frequency was measured.
4. The conducted spurious emission for the whole frequency range was taken.
5. Make the measurement with the spectrum analyzer's RBW = 1MHz, VBW = 3MHz.
6. Set spectrum analyzer with RMS detector.
7. Taking the record of maximum spurious emission.
8. The RF fundamental frequency should be excluded against the limit line in the operating frequency band.
9. The limit line is -40dBm/MHz.



## 3.7 Frequency Stability

### 3.7.1 Description of Frequency Stability Measurement

The frequency stability shall be measured by variation of ambient temperature and variation of primary supply voltage to ensure that the fundamental emission stays within the authorized frequency block. The frequency stability of the transmitter shall be maintained within  $\pm 0.00025\%$  ( $\pm 2.5\text{ppm}$ ) of the center frequency

### 3.7.2 Test Procedures for Temperature Variation

The testing follows FCC KDB 971168 D01 v03r01 Section 9.0.

1. The EUT was set up in the thermal chamber and connected with the system simulator.
2. With power OFF, the temperature was decreased to  $-30^{\circ}\text{C}$  and the EUT was stabilized before testing. Power was applied and the maximum change in frequency was recorded within one minute.
3. With power OFF, the temperature was raised in  $10^{\circ}\text{C}$  step up to  $50^{\circ}\text{C}$ . The EUT was stabilized at each step for at least half an hour. Power was applied and the maximum frequency change was recorded within one minute.

### 3.7.3 Test Procedures for Voltage Variation

The testing follows FCC KDB 971168 D01 v03r01 Section 9.0.

1. The EUT was placed in a temperature chamber at  $25\pm 5^{\circ}\text{C}$  and connected with the system simulator.
2. The power supply voltage to the EUT was varied from 85% to 115% of the nominal value measured at the input to the EUT.
3. The variation in frequency was measured for the worst case.

## 4 Radiated Test Items

### 4.1 Measuring Instruments

See list of measuring instruments of this test report.

### 4.2 Test Setup

#### 4.2.1 For radiated test below 30MHz

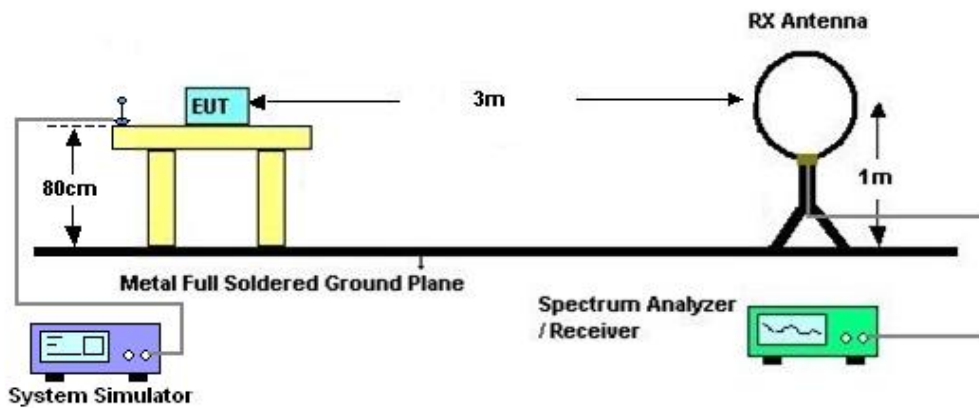

#### 4.2.2 For radiated test from 30MHz to 1GHz

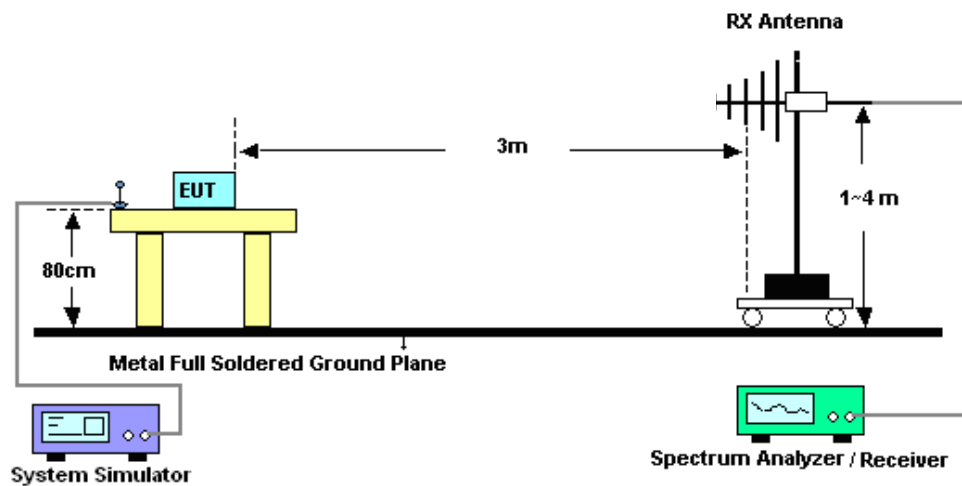

### 4.2.3 For radiated test above 1GHz

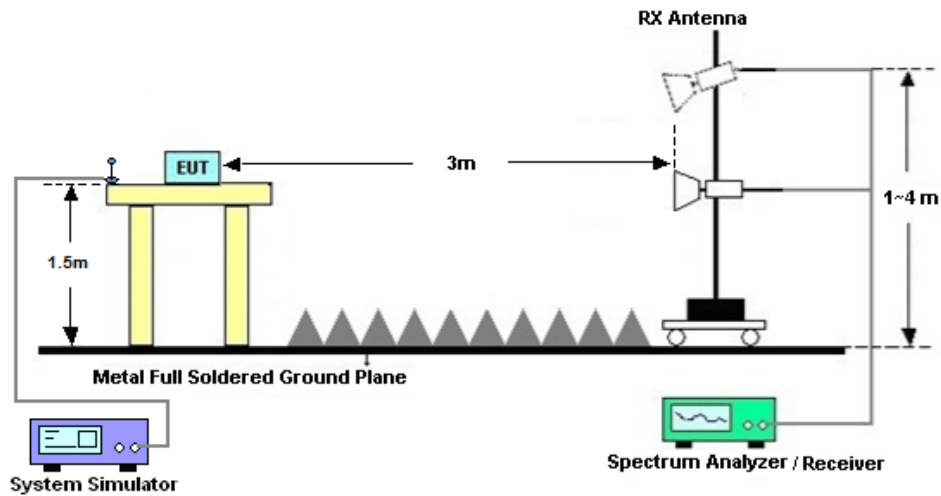

### 4.3 Test Result of Radiated Test

The low frequency, which started from 9 kHz to 30MHz, was pre-scanned and the result which was 20dB lower than the limit line was not reported.

Please refer to Appendix B.



## 4.4 Radiated Spurious Emission

### 4.4.1 Description of Radiated Spurious Emission Measurement

The radiated spurious emission was measured by substitution method according to ANSI / TIA-603-E. The power of any emission outside of the authorized operating frequency ranges must be attenuated below the transmitter power (P) by a factor of at least -40dBm / MHz. The spectrum is scanned from 30 MHz up to a frequency including its 10th harmonic.

### 4.4.2 Test Procedures

1. The EUT was placed on a turntable with 0.8 meter height for frequency below 1GHz and 1.5 meter height for frequency above 1GHz respectively above ground.
2. The EUT was set 3 meters from the receiving antenna mounted on the antenna tower.
3. The table was rotated 360 degrees to determine the position of the highest spurious emission.
4. The height of the receiving antenna is varied between 1m to 4m to search the maximum spurious emission for both horizontal and vertical polarizations.
5. During the measurement, the system simulator parameters were set to force the EUT transmitting at maximum output power.
6. Make the measurement with the spectrum analyzer's RBW = 1MHz, VBW = 3MHz, taking the record of maximum spurious emission.
7. A horn antenna was substituted in place of the EUT and was driven by a signal generator. Tune the output power of signal generator to the same emission level with EUT maximum spurious emission.  
$$\text{EIRP (dBm)} = \text{S.G. Power} - \text{Tx Cable Loss} + \text{Tx Antenna Gain}$$
$$\text{ERP (dBm)} = \text{EIRP} - 2.15$$
8. The RF fundamental frequency should be excluded against the limit line in the operating frequency band.  
The limit line is -40dBm/MHz



## 5 List of Measuring Equipment

Instrument	Manufacturer	Model No.	Serial No.	Characteristics	Calibration Date	Test Date	Due Date	Remark
Spectrum Analyzer	R&S	FSV40	101040	10Hz~40GHz	Oct. 14, 2021	Nov. 22, 2021~ Dec. 16, 2021	Oct. 13, 2022	Conducted (TH01-KS)
Power divider	STI	STI08-0055	-	0.5~40GHz	Aug. 26, 2021	Nov. 22, 2021~ Dec. 16, 2021	Aug. 25, 2022	Conducted (TH01-KS)
Temperature & humidity chamber	Hongzhan	LP-150U	H2014011 440	-40~+150°C 20%~95%RH	Jul. 12, 2021	Nov. 22, 2021~ Dec. 16, 2021	Jul. 11, 2022	Conducted (TH01-KS)
EXA Spectrum Analyzer	Keysight	N9010A	MY551502 44	10Hz-44G,MAX 30dB	Apr. 13, 2021	Dec. 05, 2021	Apr. 12, 2022	Radiation (03CH04-KS)
Loop Antenna	R&S	HFH2-Z2	100321	9kHz~30MHz	Oct. 30, 2021	Dec. 05, 2021	Oct. 29, 2022	Radiation (03CH04-KS)
Bilog Antenna	TeseQ	CBL6111D	49922	30MHz-1GHz	May 30, 2021	Dec. 05, 2021	May 29, 2022	Radiation (03CH04-KS)
Horn Antenna	Schwarzbeck	BBHA9120D	1356	1GHz~18GHz	Apr. 18, 2021	Dec. 05, 2021	Apr. 17, 2022	Radiation (03CH04-KS)
SHF-EHF Horn	Com-power	AH-840	101070	18GHz~40GHz	Jan. 06, 2021	Dec. 05, 2021	Jan. 05, 2022	Radiation (03CH04-KS)
Amplifier	SONOMA	310N	187289	9KHz-1GHz	Jan. 06, 2021	Dec. 05, 2021	Jan. 05, 2022	Radiation (03CH04-KS)
Amplifier	MITEQ	EM18G40GG A	060728	18~40GHz	Jan. 07, 2021	Dec. 05, 2021	Jan. 06, 2022	Radiation (03CH04-KS)
high gain Amplifier	MITEQ	AMF-7D-0010 1800-30-10P	2025788	1Ghz-18Ghz	Jan. 06, 2021	Dec. 05, 2021	Jan. 05, 2022	Radiation (03CH04-KS)
Amplifier	Keysight	83017A	MY572801 06	500MHz~26.5G Hz	Oct. 13, 2021	Dec. 05, 2021	Oct. 12, 2022	Radiation (03CH04-KS)
AC Power Source	Chroma	61601	F1040900 04	N/A	NCR	Dec. 05, 2021	NCR	Radiation (03CH04-KS)
Turn Table	ChamPro	EM 1000-T	060762-T	0~360 degree	NCR	Dec. 05, 2021	NCR	Radiation (03CH04-KS)
Antenna Mast	ChamPro	EM 1000-A	060762-A	1 m~4 m	NCR	Dec. 05, 2021	NCR	Radiation (03CH04-KS)

NCR: No Calibration Required



## 6 Uncertainty of Evaluation

### Uncertainty of Radiated Emission Measurement (30 MHz ~ 1000 MHz)

Measuring Uncertainty for a Level of Confidence of 95% (U = 2Uc(y))	3.3dB
---	-------

### Uncertainty of Radiated Emission Measurement (1 GHz ~ 18 GHz)

Measuring Uncertainty for a Level of Confidence of 95% (U = 2Uc(y))	2.8dB
---	-------

### Uncertainty of Radiated Emission Measurement (18 GHz ~ 40 GHz)

Measuring Uncertainty for a Level of Confidence of 95% (U = 2Uc(y))	2.8dB
---	-------

----- THE END -----



### Appendix A. Test Results of Conducted Test

Test Engineer :	Yong He	Temperature :	21~24°C
		Relative Humidity :	45~51%

### Conducted Output Power(Average power) and EIRP

Ant.10:

BW [MHz]	Modulation	RB Size	RB Offset	Power Low	Power Middle	Power High	EIRP(W)		
				Ch. / Freq.	Ch. / Freq.	Ch. / Freq.	L	M	H
Channel				55340	55990	56640			
Frequency (MHz)				3560	3625	3690	L	M	H
20	QPSK	1	0	18.21	18.1	18.14	0.0332	0.0324	0.0327
20	QPSK	1	99	18.31	18.12	18.16	0.0340	0.0325	0.0328
20	QPSK	100	0	18.39	18.23	18.25	0.0346	0.0333	0.0335
20	QPSK	1	13	21.63	21.61	21.02	0.0729	0.0726	0.0634
20	QPSK	1	16	22.52	22.42	21.9	0.0895	0.0875	0.0776
20	QPSK	54	24	21.93	21.4	21.04	0.0782	0.0692	0.0637
20	QPSK	24	0	21.75	21.36	21.03	0.0750	0.0685	0.0635
20	QPSK	24	76	21.92	21.44	21.07	0.0780	0.0698	0.0641
20	QPSK	1	83	22.73	22.54	21.9	0.0940	0.0899	0.0776
20	QPSK	1	86	21.7	21.72	20.95	0.0741	0.0745	0.0624
20	16QAM	1	0	17.22	17.13	17.16	0.0264	0.0259	0.0261
20	16QAM	1	99	17.71	17.32	16.89	0.0296	0.0270	0.0245
20	16QAM	100	0	17.8	17.41	17.01	0.0302	0.0276	0.0252
20	16QAM	1	13	20.51	20.88	20.19	0.0564	0.0614	0.0524
20	16QAM	1	16	21.93	21.83	21.07	0.0782	0.0764	0.0641
20	16QAM	54	24	20.8	20.42	20.03	0.0603	0.0552	0.0505
20	16QAM	24	0	20.78	20.34	19.94	0.0600	0.0542	0.0494
20	16QAM	24	76	20.87	20.43	20.11	0.0612	0.0553	0.0514
20	16QAM	1	83	21.85	21.38	20.94	0.0767	0.0689	0.0622
20	16QAM	1	86	20.6	20.18	20.05	0.0575	0.0522	0.0507
20	64QAM	1	0	16.32	16.3	16.31	0.0215	0.0214	0.0214
20	64QAM	1	99	16.74	16.76	15.81	0.0237	0.0238	0.0191
20	64QAM	100	0	16.88	16.41	16.03	0.0244	0.0219	0.0201
20	64QAM	1	13	19.62	19.21	19.01	0.0459	0.0418	0.0399
20	64QAM	1	16	20.6	20.65	20.23	0.0575	0.0582	0.0528
20	64QAM	54	24	19.79	19.41	19.09	0.0478	0.0438	0.0406
20	64QAM	24	0	19.72	19.5	19.03	0.0470	0.0447	0.0401
20	64QAM	24	76	19.82	19.57	19.13	0.0481	0.0454	0.0410
20	64QAM	1	83	20.34	20.01	19.97	0.0542	0.0502	0.0498
20	64QAM	1	86	19.85	19.18	19.32	0.0484	0.0415	0.0429
20	256QAM	1	0	13.5	13.58	13.04	0.0112	0.0114	0.0101
20	256QAM	1	99	13.84	13.29	13.11	0.0121	0.0107	0.0103
20	256QAM	100	0	14.85	14.33	14.03	0.0153	0.0136	0.0127
20	256QAM	1	13	16.76	16.82	16.13	0.0238	0.0241	0.0206
20	256QAM	1	16	17.84	17.27	17.05	0.0305	0.0267	0.0254



20	256QAM	54	24	17.8	17.48	17.05	0.0302	0.0281	0.0254
20	256QAM	24	0	17.8	17.4	17.02	0.0302	0.0275	0.0252
20	256QAM	24	76	17.89	17.36	17.13	0.0308	0.0273	0.0259
20	256QAM	1	83	17.68	17.59	16.67	0.0294	0.0288	0.0233
20	256QAM	1	86	16.92	16.65	16.2	0.0247	0.0232	0.0209
Channel				55315	55990	56665	EIRP(W)		
Frequency (MHz)				3557.5	3625	3692.5	L	M	H
15	QPSK	1	0	18.21	18.05	18.09	0.0332	0.0320	0.0323
15	QPSK	1	7	22.53	22.21	21.84	0.0897	0.0834	0.0766
15	QPSK	16	0	22.72	22.25	22.02	0.0938	0.0841	0.0798
15	QPSK	45	15	21.82	21.43	21.06	0.0762	0.0697	0.0640
15	QPSK	16	59	22.75	22.3	21.93	0.0944	0.0851	0.0782
15	QPSK	1	74	18.72	18.15	17.86	0.0373	0.0327	0.0306
15	QPSK	1	67	22.56	22.32	21.88	0.0904	0.0855	0.0773
15	QPSK	75	0	19.92	19.34	19.04	0.0492	0.0431	0.0402
15	16QAM	1	0	17.24	17.16	17.08	0.0265	0.0261	0.0256
15	16QAM	1	7	21.52	21.87	20.84	0.0711	0.0771	0.0608
15	16QAM	16	0	21.66	20.3	21.04	0.0735	0.0537	0.0637
15	16QAM	45	15	20.87	20.4	20.07	0.0612	0.0550	0.0509
15	16QAM	16	59	21.75	21.36	21.04	0.0750	0.0685	0.0637
15	16QAM	1	74	17.26	17.33	16.78	0.0267	0.0271	0.0239
15	16QAM	1	67	21.82	21.71	20.87	0.0762	0.0743	0.0612
15	16QAM	75	0	18.79	18.39	18.03	0.0379	0.0346	0.0318
15	64QAM	1	0	16.33	16.21	16.23	0.0215	0.0209	0.0210
15	64QAM	1	7	20.68	20.5	16.09	0.0586	0.0562	0.0204
15	64QAM	16	0	20.75	20.37	19.98	0.0596	0.0546	0.0499
15	64QAM	45	15	19.71	19.38	19.04	0.0469	0.0435	0.0402
15	64QAM	16	59	20.71	20.33	20.02	0.0590	0.0541	0.0504
15	64QAM	1	74	16.64	16.51	16.2	0.0231	0.0224	0.0209
15	64QAM	1	67	20.73	20.19	20.13	0.0593	0.0524	0.0516
15	64QAM	75	0	17.81	17.39	16.98	0.0303	0.0275	0.0250
15	256QAM	1	0	13.65	13.44	12.59	0.0116	0.0111	0.0091
15	256QAM	1	7	17.74	17.44	17.09	0.0298	0.0278	0.0256
15	256QAM	16	0	17.81	17.31	17.01	0.0303	0.0270	0.0252
15	256QAM	45	15	17.91	17.31	17.03	0.0310	0.0270	0.0253
15	256QAM	16	59	17.78	17.24	17.08	0.0301	0.0265	0.0256
15	256QAM	1	74	13.7	13.45	13.18	0.0117	0.0111	0.0104
15	256QAM	1	67	17.7	17.65	17.34	0.0295	0.0292	0.0272
15	256QAM	75	0	15.8	15.4	15.02	0.0191	0.0174	0.0159
Channel				55290	55990	56690	EIRP(W)		
Frequency (MHz)				3555	3625	3695	L	M	H
10	QPSK	1	0	22.3	22.18	22.23	0.0851	0.0828	0.0838
10	16QAM	1	0	21.44	21.23	21.29	0.0698	0.0665	0.0675
10	64QAM	1	0	20.46	20.37	20.41	0.0557	0.0546	0.0551
10	256QAM	1	0	17.82	17.23	17.02	0.0303	0.0265	0.0252
Channel				55265	55990	56715	EIRP(W)		
Frequency (MHz)				3552.5	3625	3697.5	L	M	H
5	QPSK	1	0	22.24	22.15	22.12	0.0839	0.0822	0.0817
5	16QAM	1	0	21.46	21.28	21.22	0.0701	0.0673	0.0664
5	64QAM	1	0	20.35	20.37	20.35	0.0543	0.0546	0.0543





---

5	256QAM	1	0	17.81	17.41	17.13	0.0303	0.0276	0.0259
---	--------	---	---	-------	-------	-------	--------	--------	--------



**26dB Bandwidth**

Mode	LTE Band 48 : 26dB BW(MHz)			
BW	20MHz			
Mod.	QPSK	16QAM	64QAM	256QAM
Middle CH	18.62	19.10	18.78	19.18

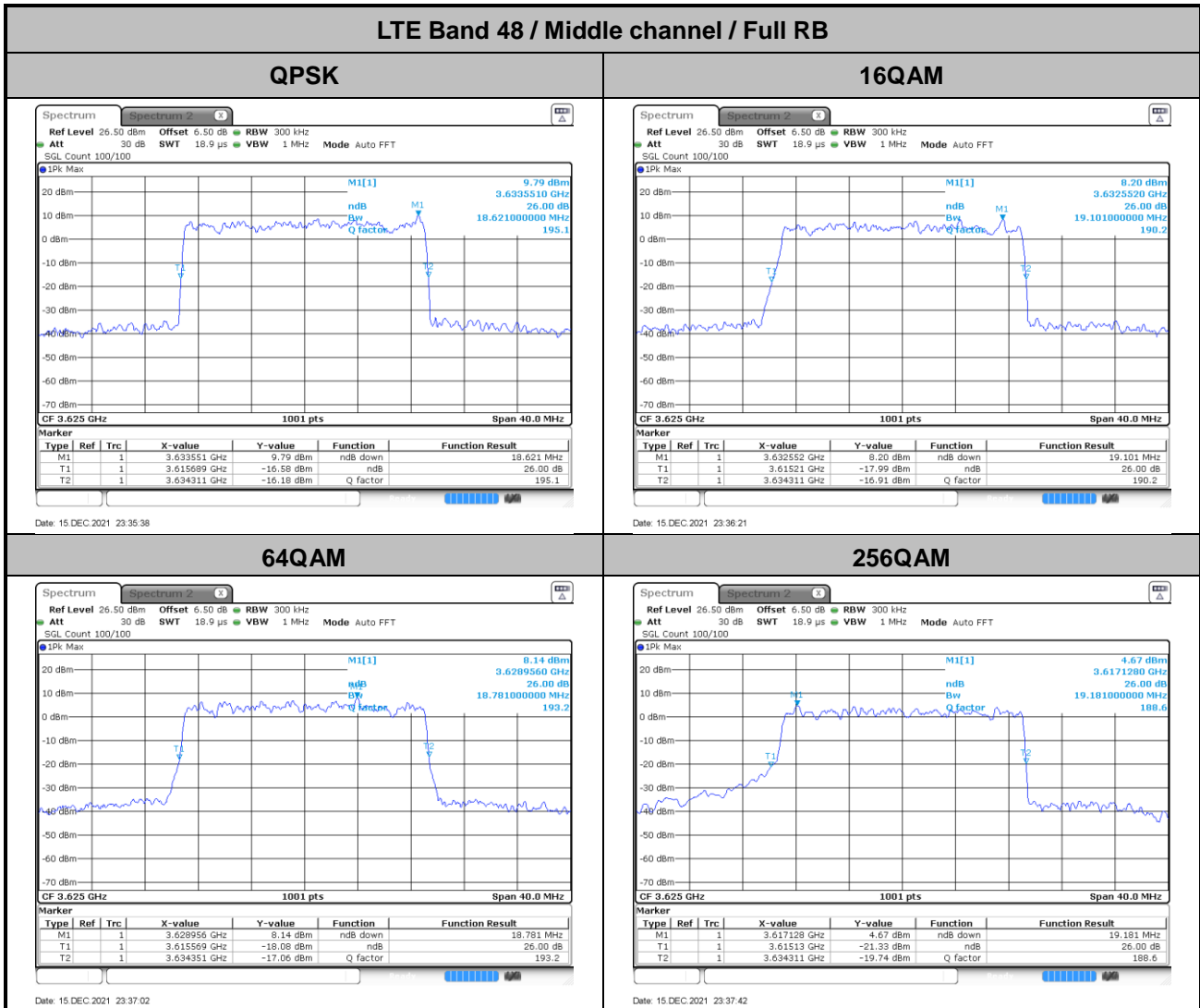



Mode	LTE Band 48 : 26dB BW(MHz)			
BW	15MHz			
Mod.	QPSK	16QAM	64QAM	256QAM
Middle CH	14.15	14.42	14.33	14.21

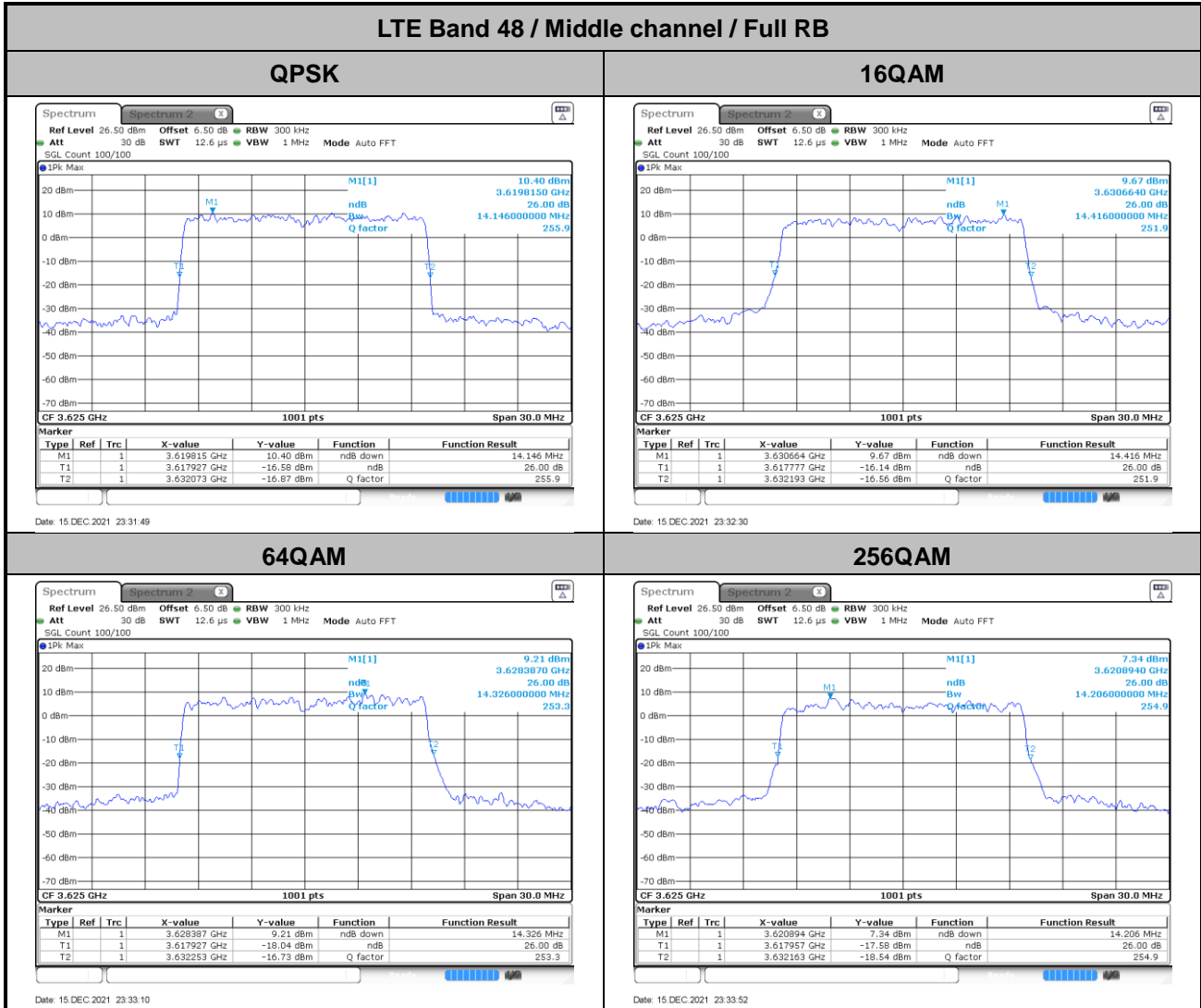



Mode	LTE Band 48 : 26dB BW(MHz)			
BW	10MHz			
Mod.	QPSK	16QAM	64QAM	256QAM
Middle CH	9.97	9.93	10.01	9.77

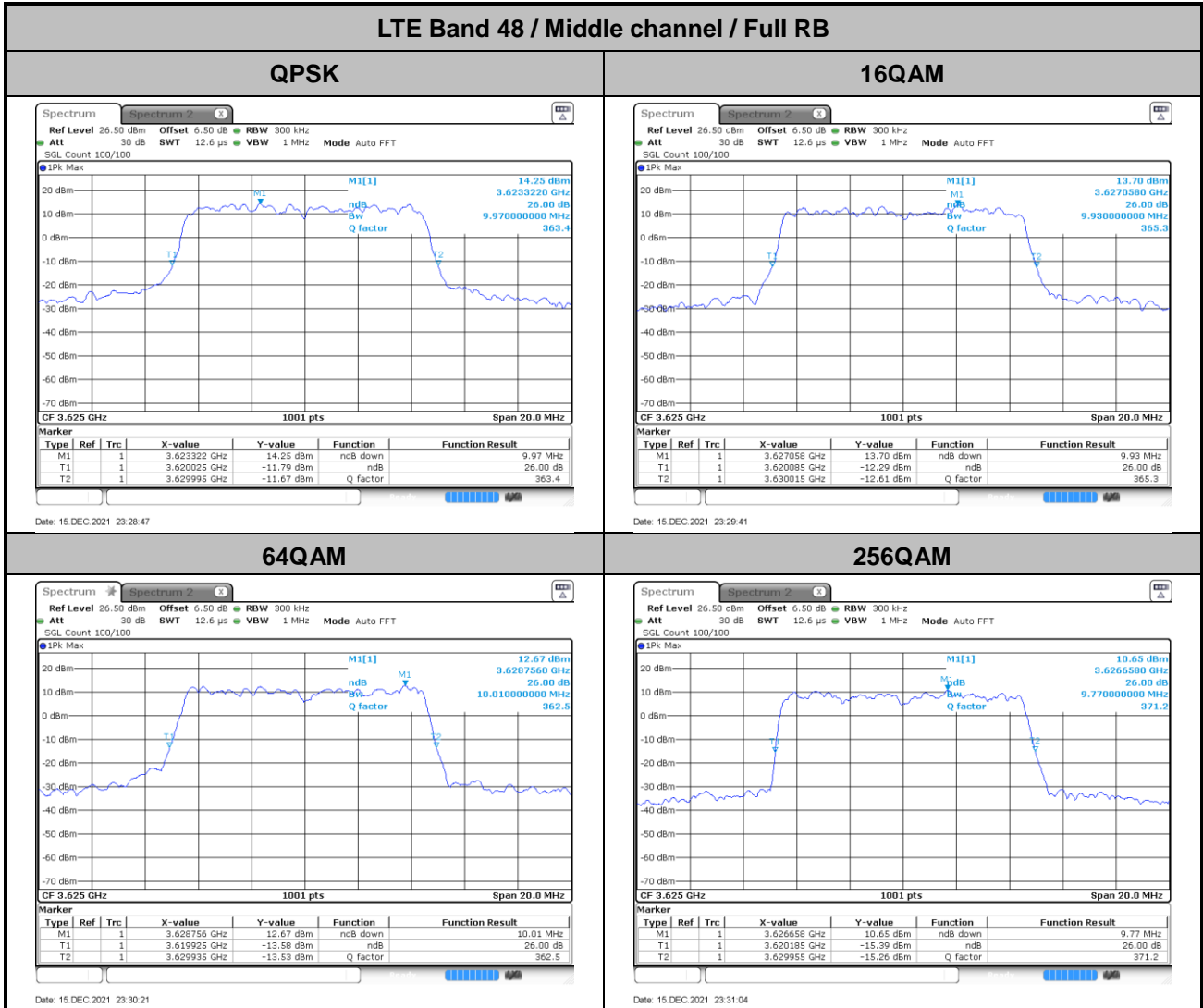



Mode	LTE Band 48 : 26dB BW(MHz)			
BW	5MHz			
Mod.	QPSK	16QAM	64QAM	256QAM
Middle CH	4.94	4.91	5.17	4.93

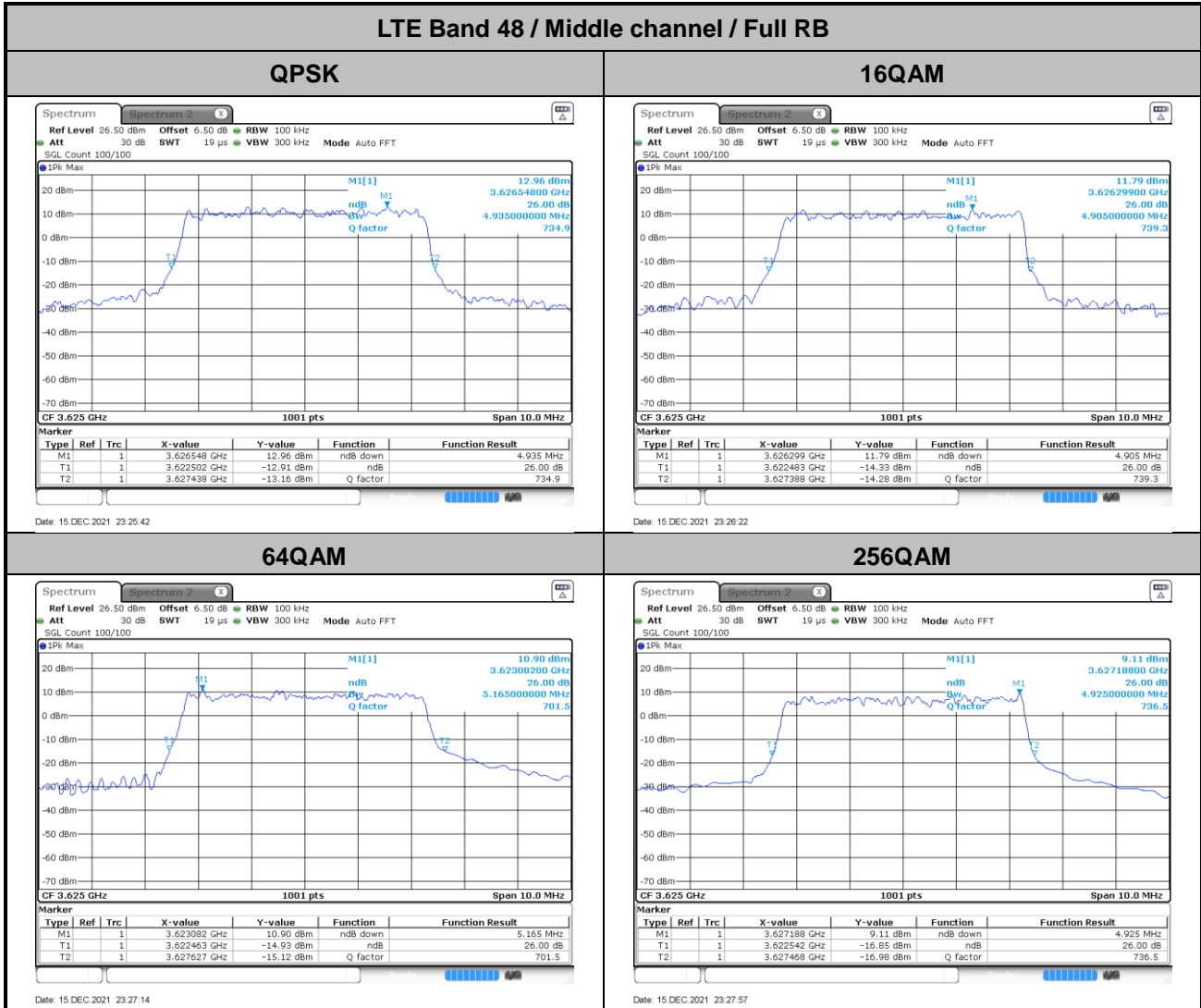



# Occupied Bandwidth

Mode	LTE Band 48 : 99%OBW(MHz)			
BW	20MHz			
Mod.	QPSK	16QAM	64QAM	256QAM
Middle CH	17.86	17.90	17.82	17.90

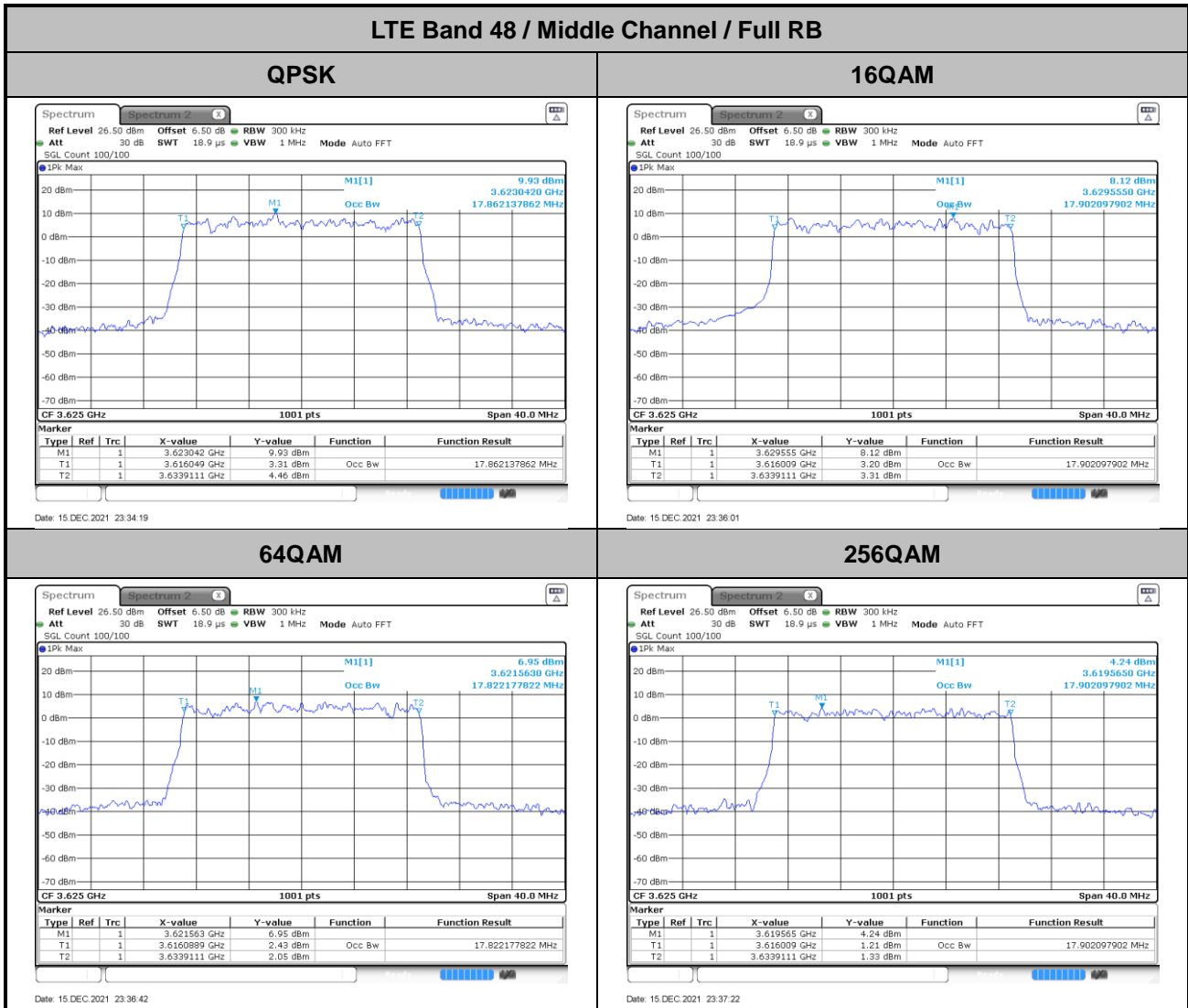



Mode	LTE Band 48 : 99%OBW(MHz)			
BW	15MHz			
Mod.	QPSK	16QAM	64QAM	256QAM
Middle CH	13.46	13.49	13.43	13.43

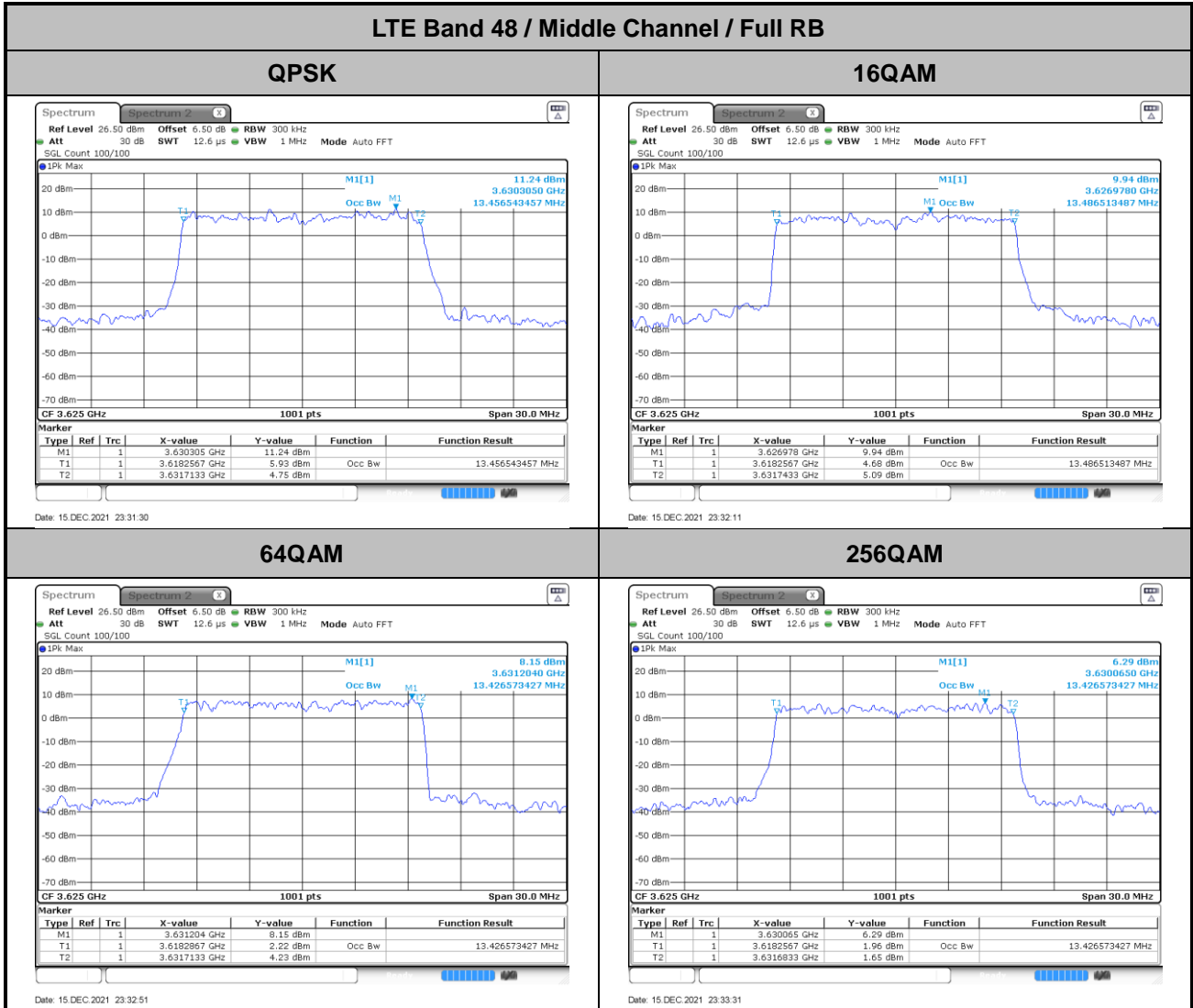



Mode	LTE Band 48 : 99%OBW(MHz)			
BW	10MHz			
Mod.	QPSK	16QAM	64QAM	256QAM
Middle CH	9.07	9.01	8.99	9.09

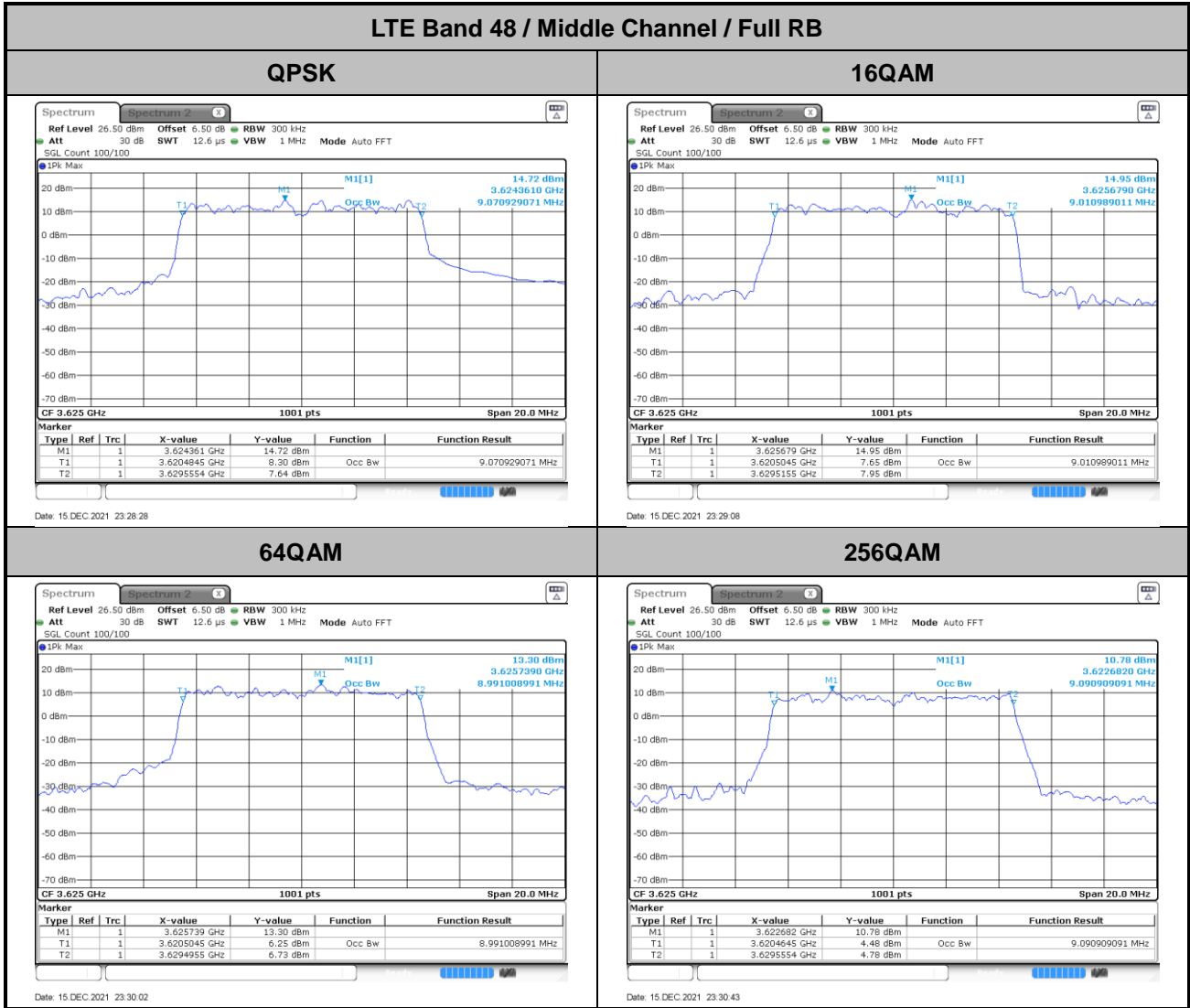





Mode	LTE Band 48 : 99%OBW(MHz)			
BW	5MHz			
Mod.	QPSK	16QAM	64QAM	256QAM
Middle CH	4.45	4.47	4.50	4.49

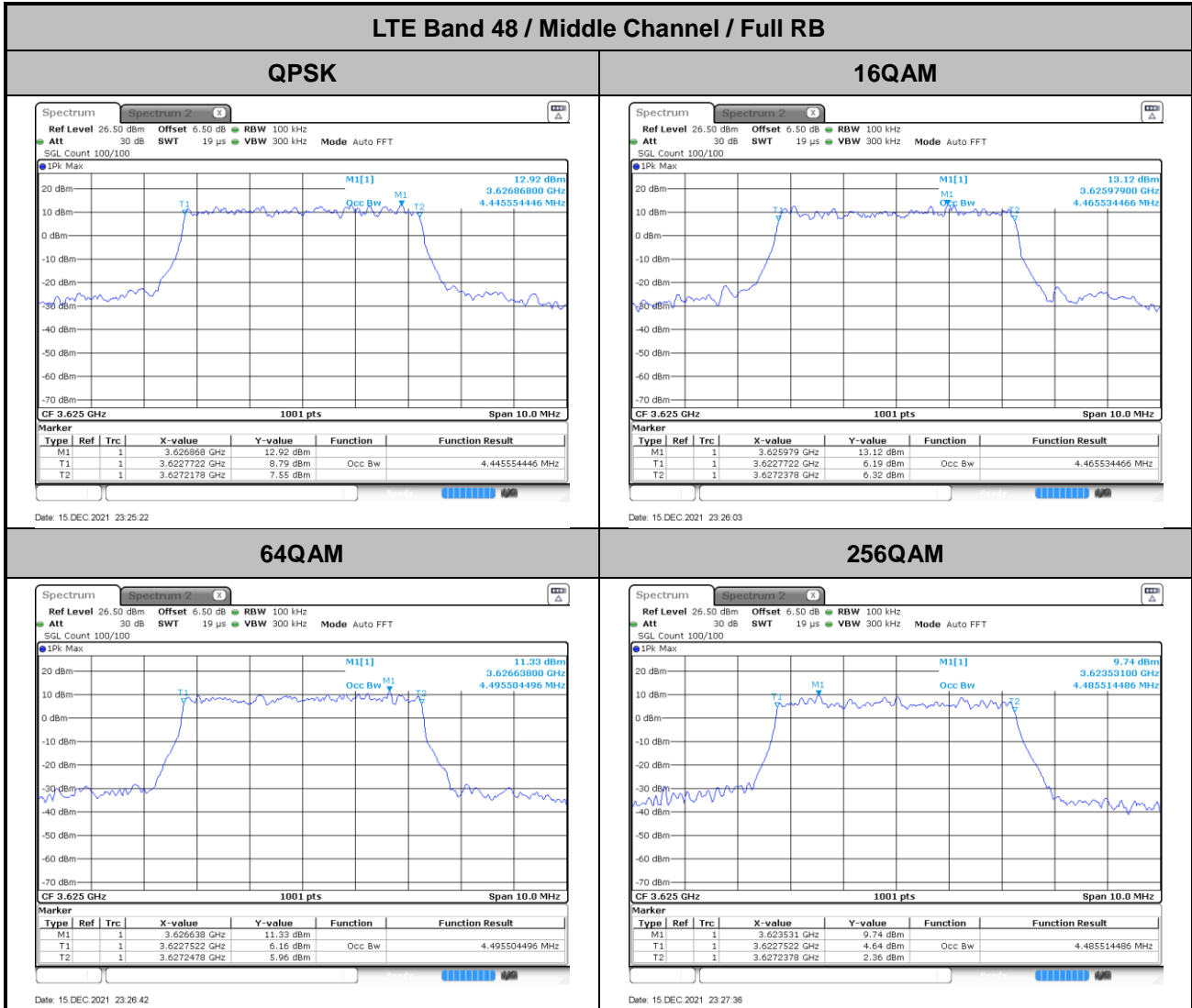



ACLR

LTE Band 48 / 5MHz

QPSK

Lowest Channel / 1RB0

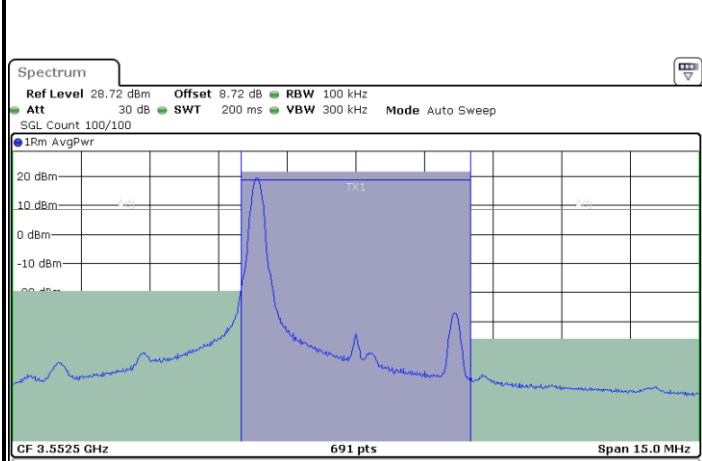

Channel	Bandwidth	Offset	Power	
TX1 (Ref)	5.000 MHz		21.66 dBm	
<b>Tx Total</b>			<b>21.66 dBm</b>	
Channel	Bandwidth	Offset	Lower	Upper
Adj	5.000 MHz	5.000 MHz	-41.27 dB	-57.69 dB

Date: 22.NOV.2021 22:39:28

Lowest Channel / 1RBmax

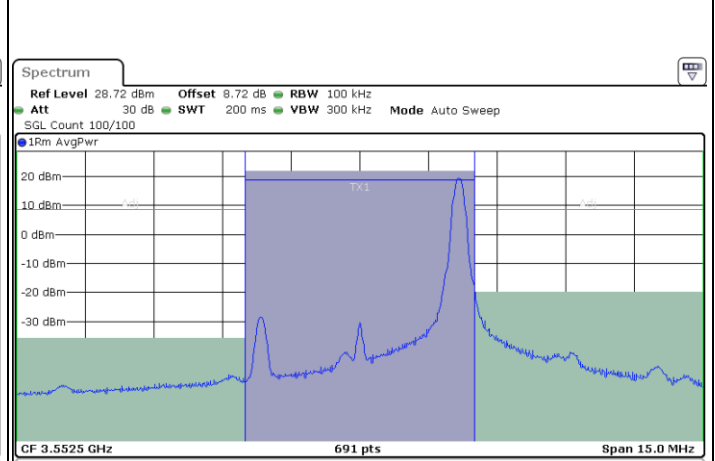

Channel	Bandwidth	Offset	Power	
TX1 (Ref)	5.000 MHz		21.71 dBm	
<b>Tx Total</b>			<b>21.71 dBm</b>	
Channel	Bandwidth	Offset	Lower	Upper
Adj	5.000 MHz	5.000 MHz	-57.58 dB	-41.66 dB

Date: 22.NOV.2021 22:55:52

Lowest Channel / Full RB

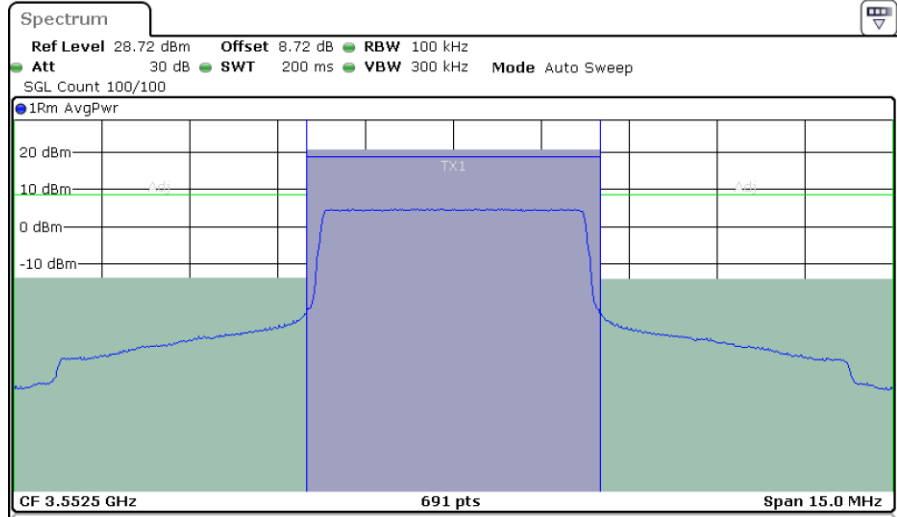

Channel	Bandwidth	Offset	Power	
TX1 (Ref)	5.000 MHz		20.72 dBm	
<b>Tx Total</b>			<b>20.72 dBm</b>	
Channel	Bandwidth	Offset	Lower	Upper
Adj	5.000 MHz	5.000 MHz	-34.55 dB	-34.95 dB

Date: 22.NOV.2021 22:58:41



LTE Band 48 / 5MHz

QPSK

Middle Channel / 1RB0

Middle Channel / 1RBmax

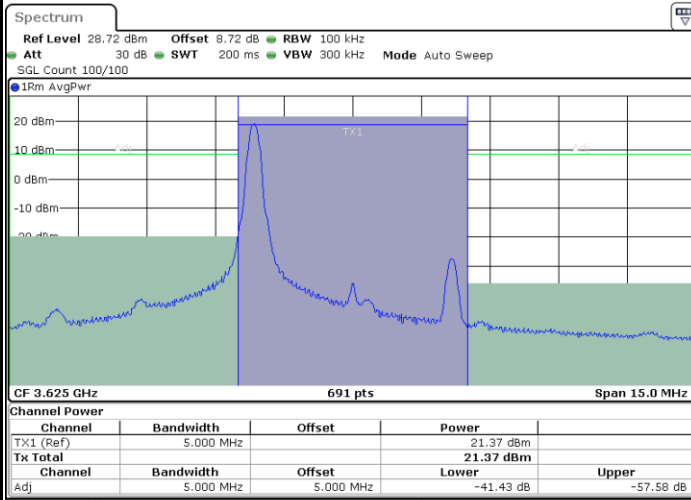

Date: 22.NOV.2021 23:47:30

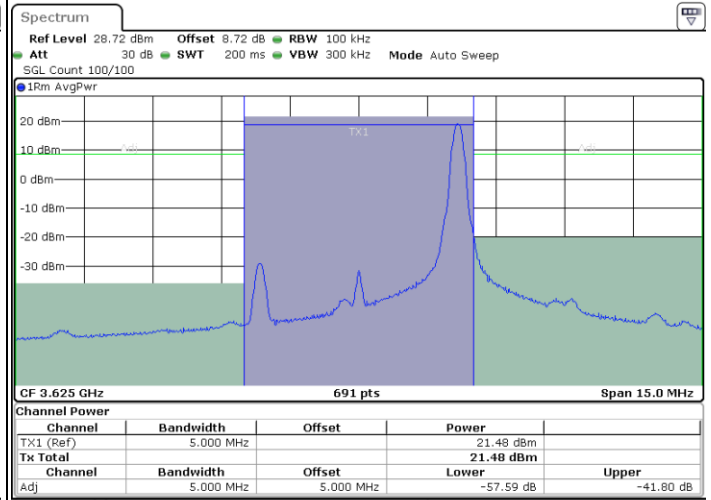

Date: 23.NOV.2021 00:05:04

Middle Channel / Full RB

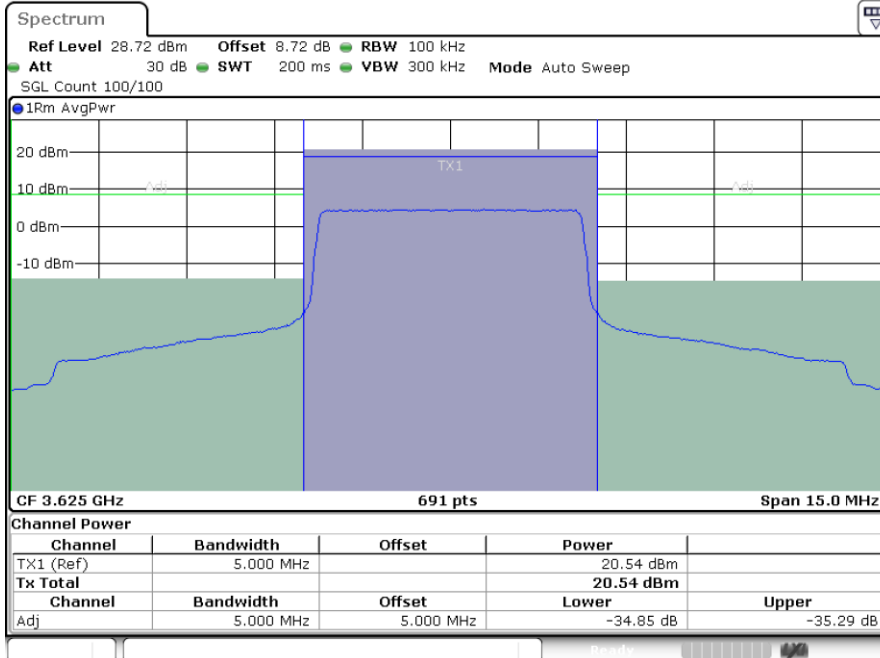

Date: 22.NOV.2021 23:45:57



LTE Band 48 / 5MHz

QPSK

Highest Channel / 1RB0

Highest Channel / 1RBmax

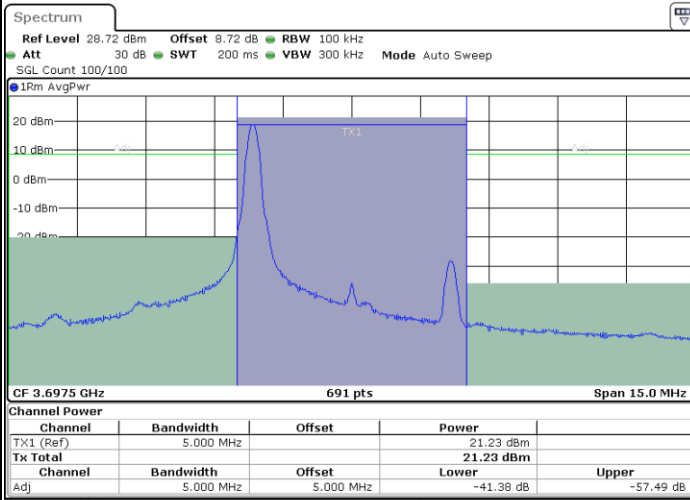

Date: 23.NOV.2021 00:07:21

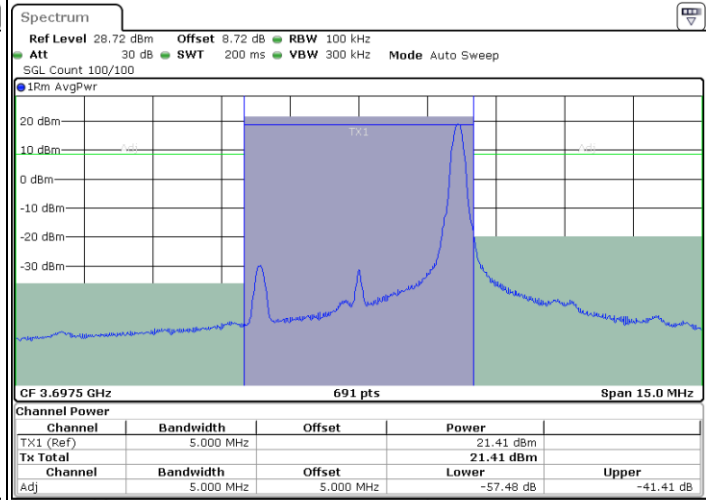

Date: 23.NOV.2021 00:30:15

Highest Channel / Full RB

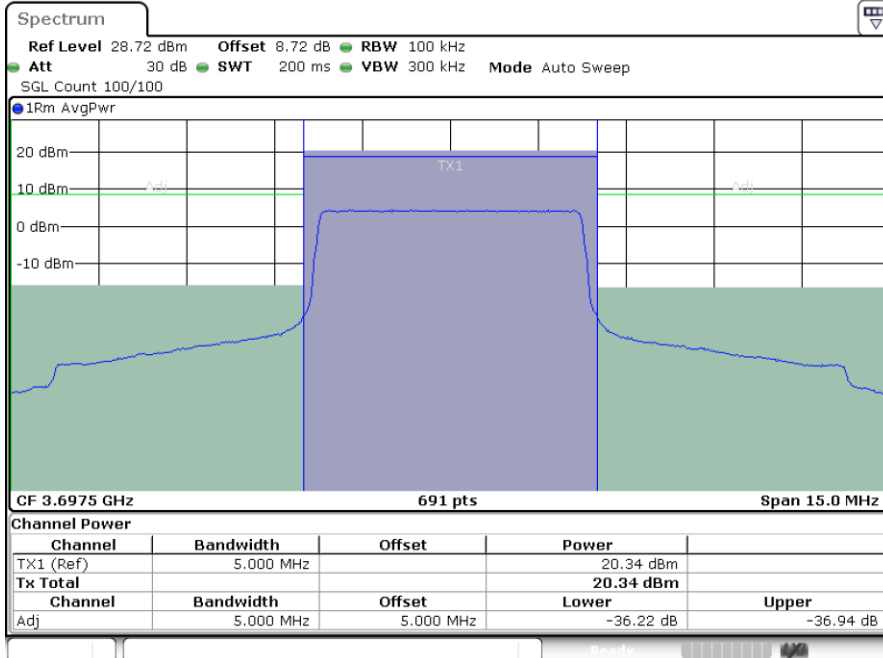

Date: 23.NOV.2021 00:32:23



**LTE Band 48 / 10MHz**

**QPSK**

**Lowest Channel / 1RB0**

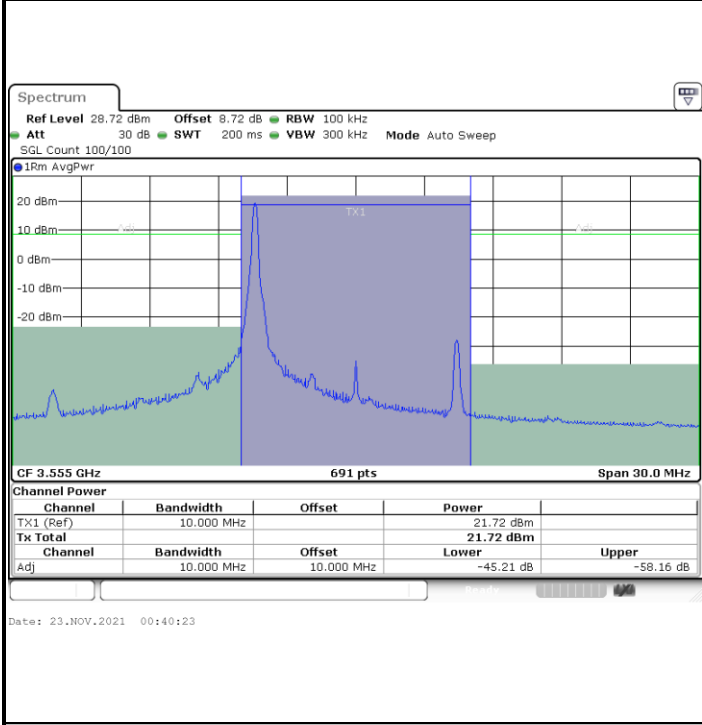

**Lowest Channel / 1RBmax**

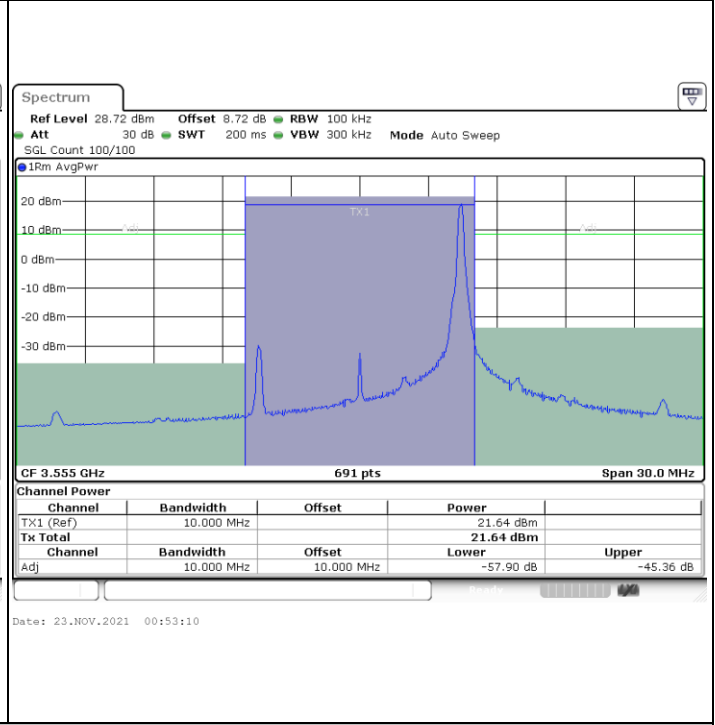

**Lowest Channel / Full RB**

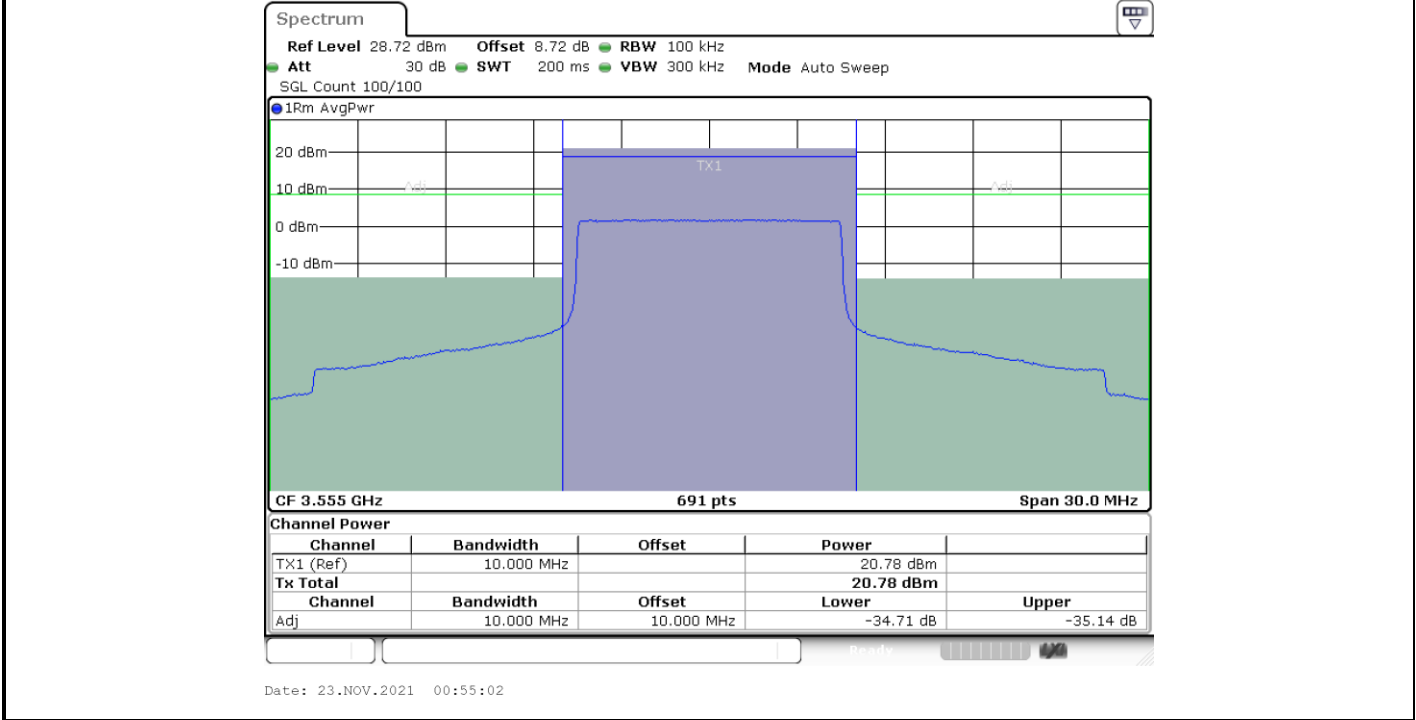



LTE Band 48 / 10MHz

QPSK

MiddleChannel / 1RB0

Middle Channel / 1RBmax

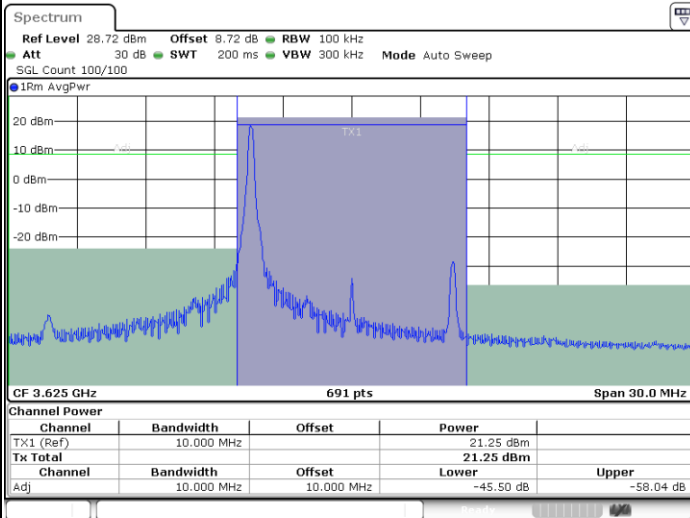

Date: 23.NOV.2021 01:04:25

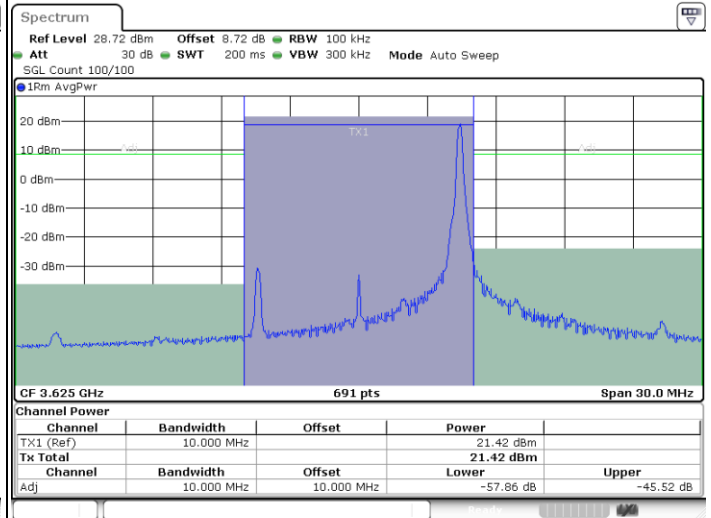

Date: 23.NOV.2021 01:15:17

Middle Channel / Full RB

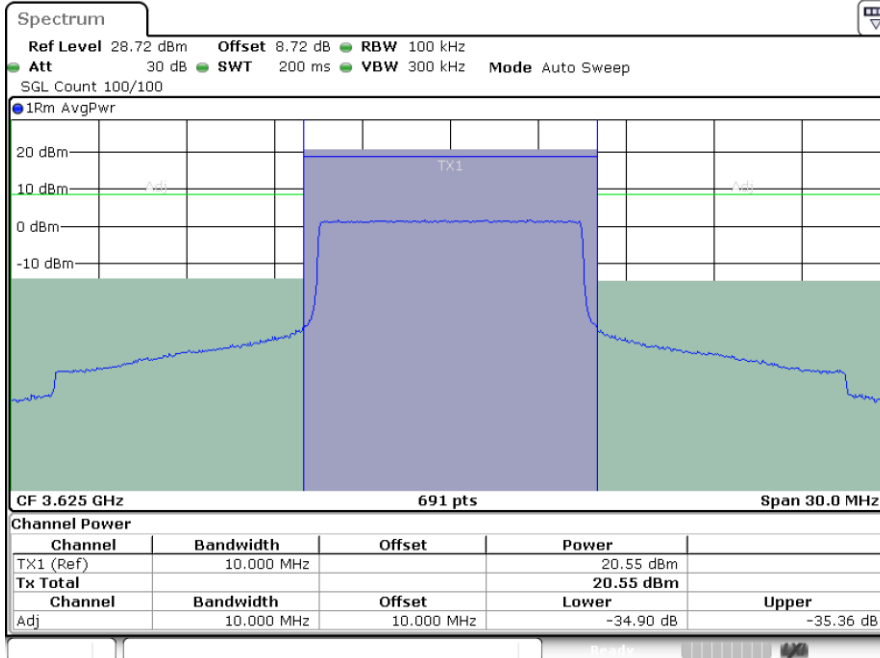

Date: 23.NOV.2021 01:16:42



LTE Band 48 / 10MHz

QPSK

Highest Channel / 1RB0

Highest Channel / 1RBmax

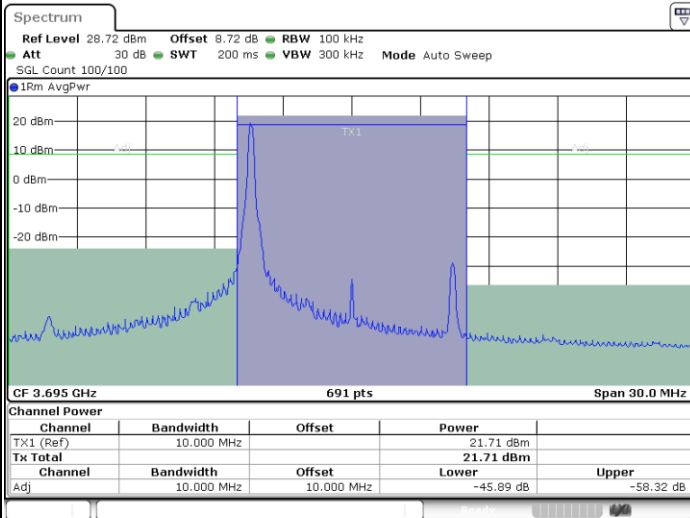

Date: 23.NOV.2021 01:29:23

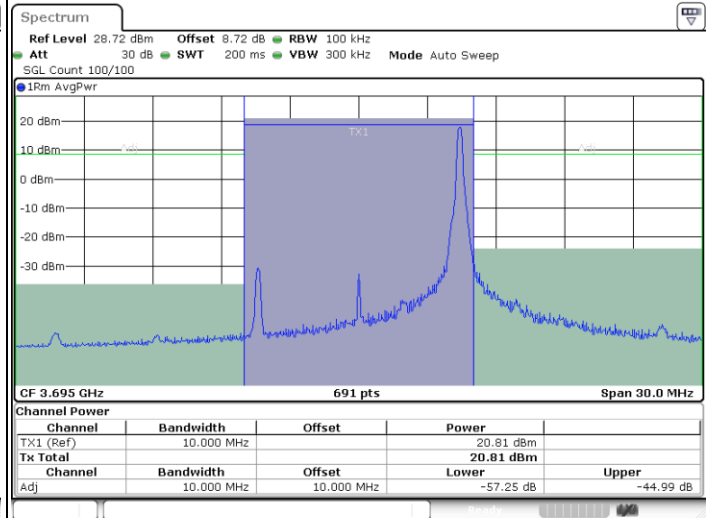

Date: 23.NOV.2021 01:47:15

Highest Channel / Full RB

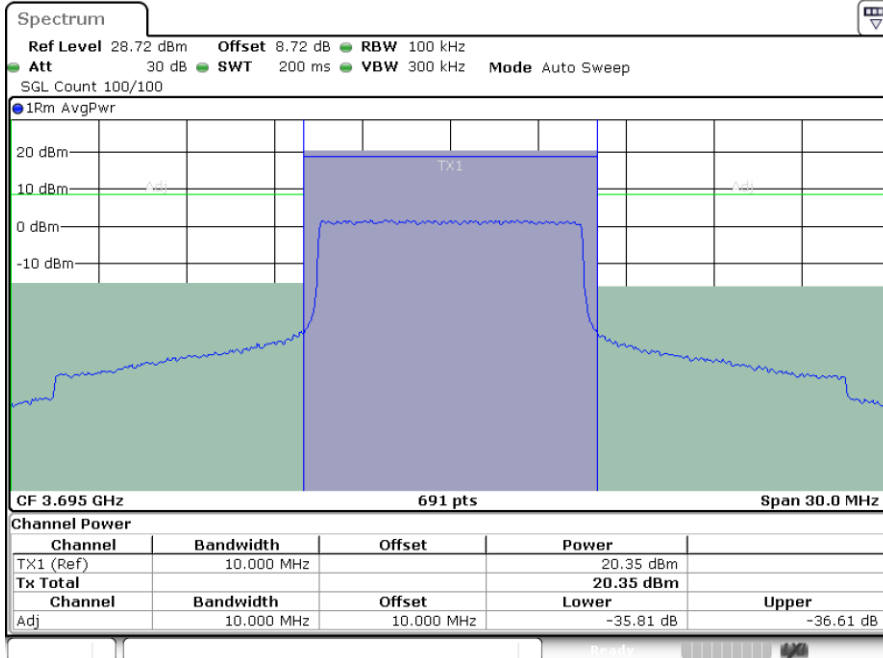

Date: 23.NOV.2021 01:51:45



LTE Band 48 / 15MHz

QPSK

Lowest Channel / 1RB0

Lowest Channel / 1RBmax

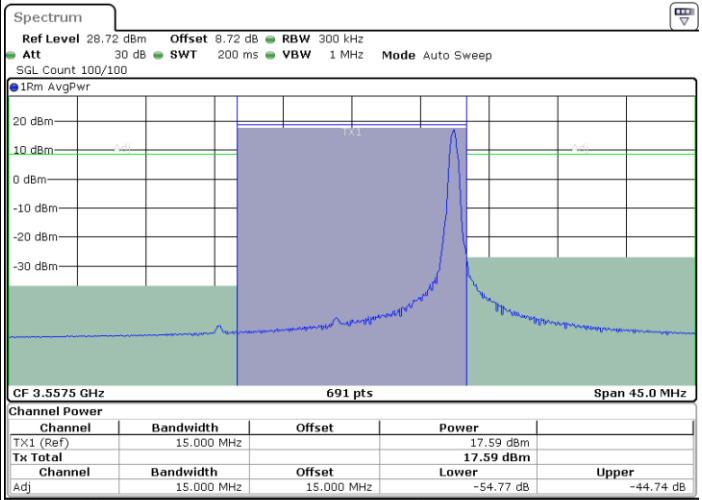
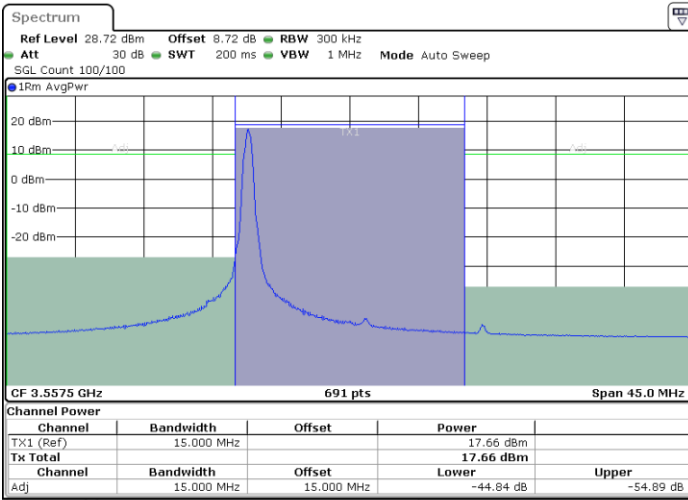

Date: 23.NOV.2021 02:31:47

Date: 23.NOV.2021 02:37:07

Lowest Channel / Full RB

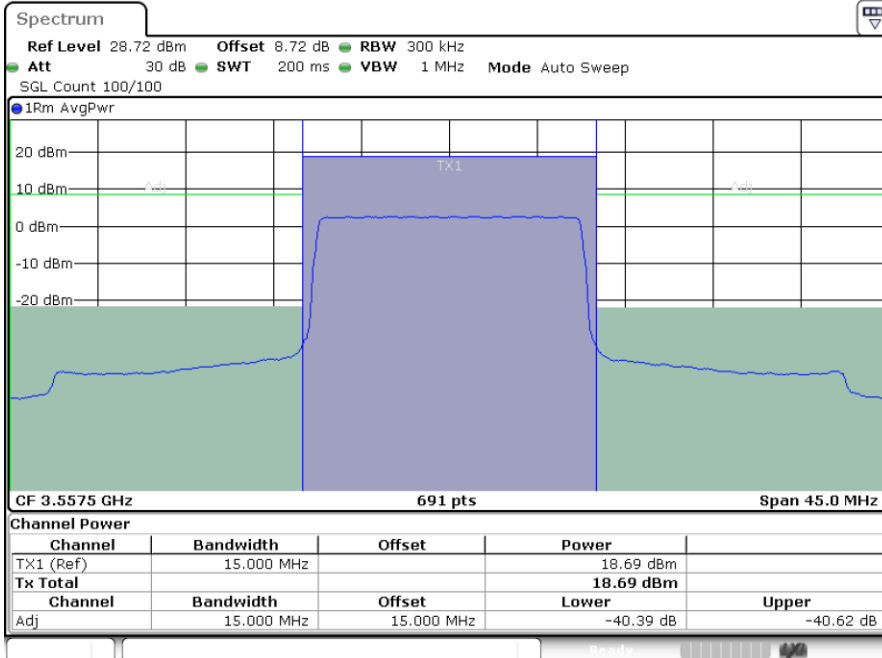

Date: 23.NOV.2021 02:38:05





LTE Band 48 / 15MHz

QPSK

Middle Channel / 1RB0

Middle Channel / 1RBmax

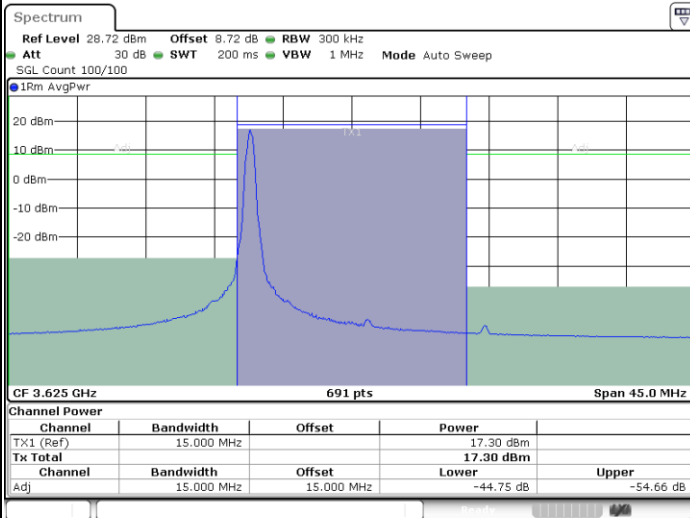

Date: 23.NOV.2021 02:41:45

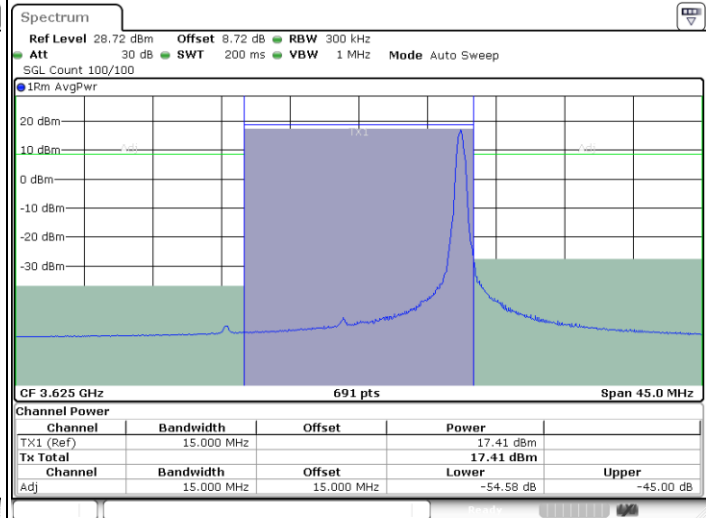

Date: 23.NOV.2021 03:18:09

Middle Channel / Full RB

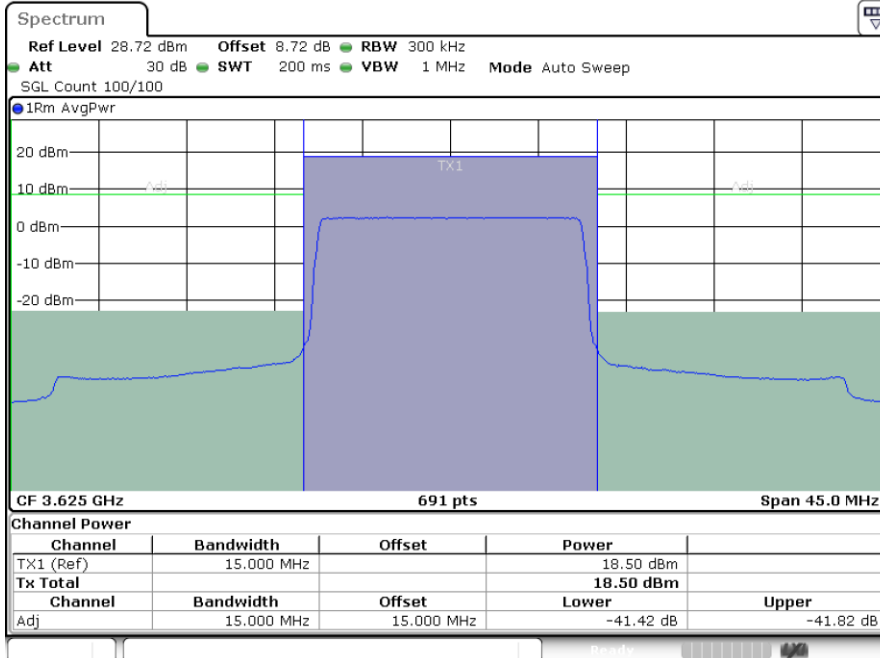

Date: 23.NOV.2021 03:19:55



LTE Band 48 / 15MHz

QPSK

Highest Channel / 1RB0

Highest Channel / 1RBmax

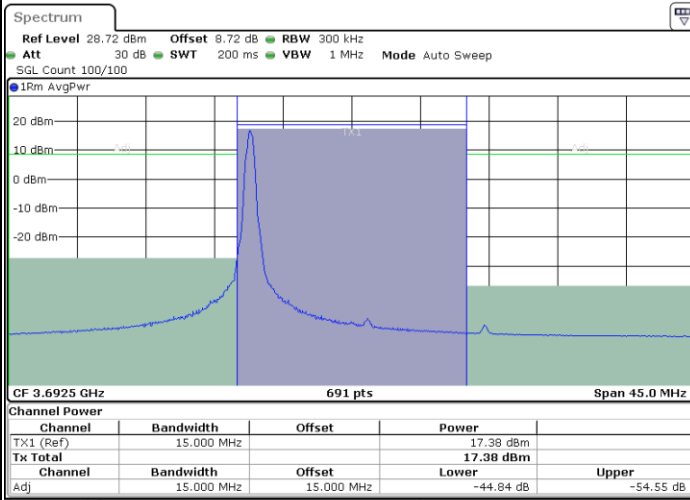

Date: 23.NOV.2021 03:27:38

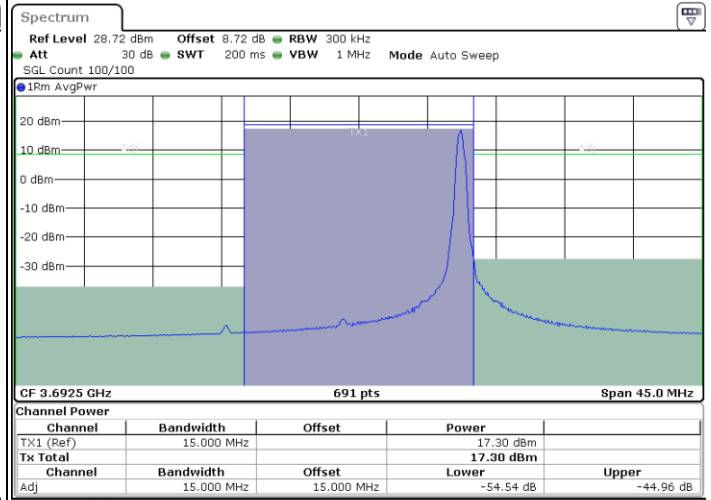

Date: 23.NOV.2021 03:45:43

Highest Channel / Full RB

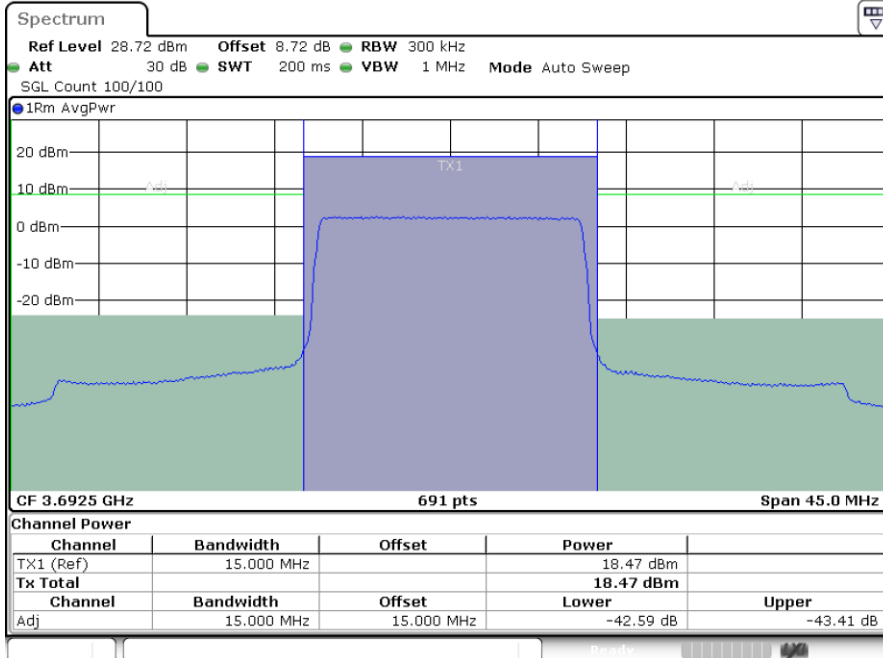

Date: 23.NOV.2021 03:47:50



LTE Band 48 / 20MHz

QPSK

Lowest Channel / 1RB0

Lowest Channel / 1RBmax

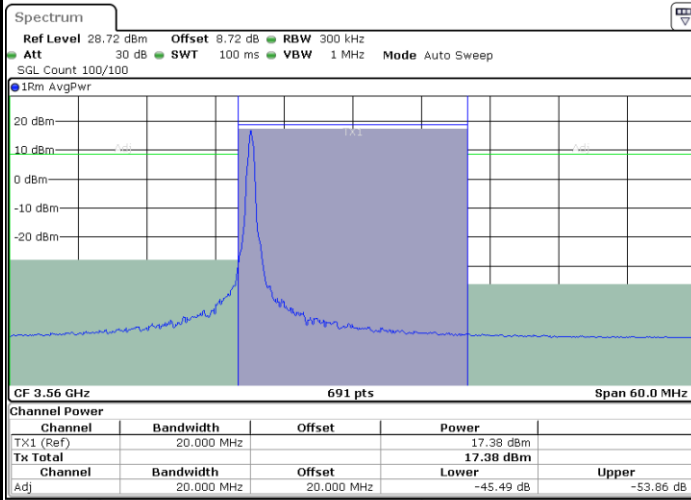

Date: 23.NOV.2021 03:57:37

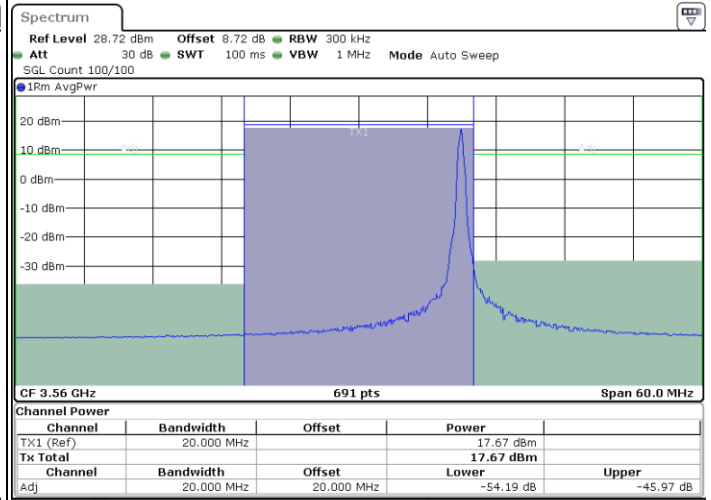

Date: 23.NOV.2021 04:10:16

Lowest Channel / Full RB

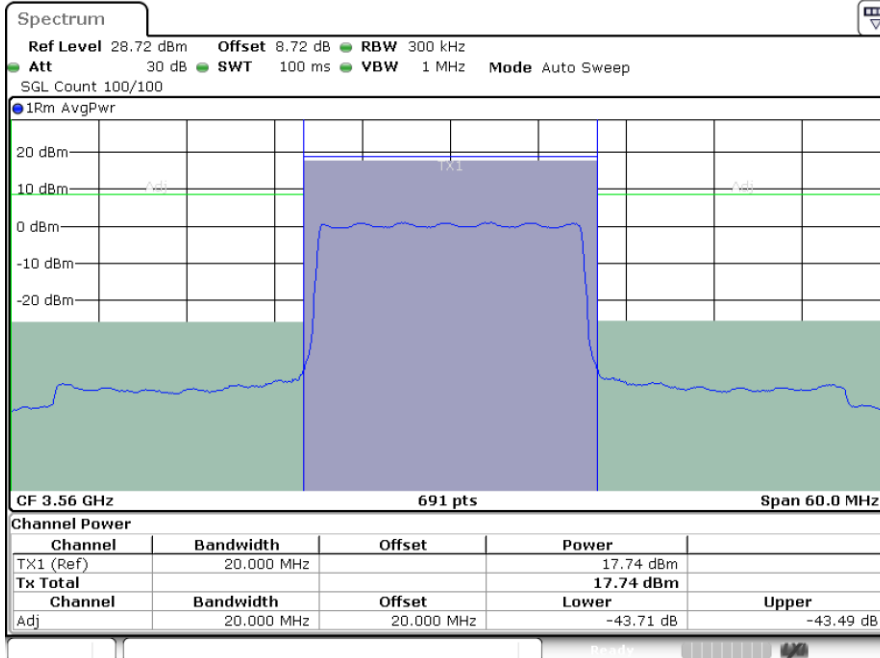

Date: 23.NOV.2021 04:12:20



LTE Band 48 / 20MHz

QPSK

Middle Channel / 1RB0

Middle Channel / 1RBmax

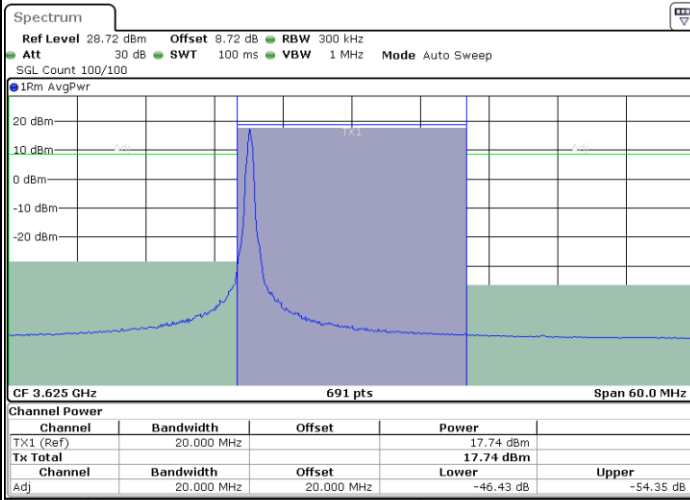

Date: 23.NOV.2021 04:21:31

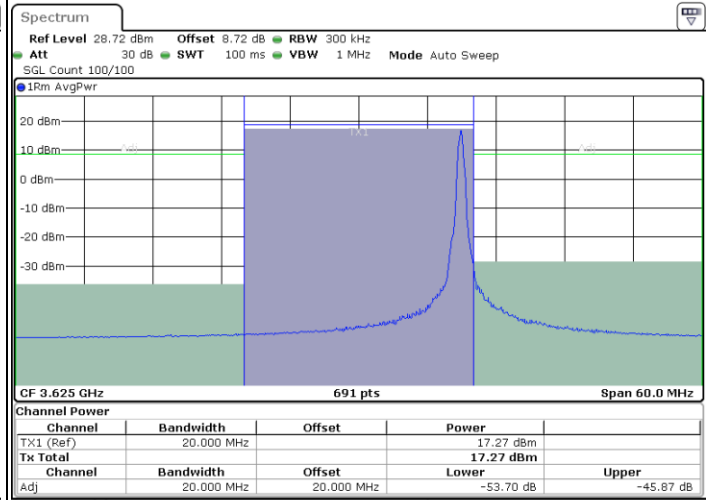

Date: 23.NOV.2021 04:33:31

Middle Channel / Full RB

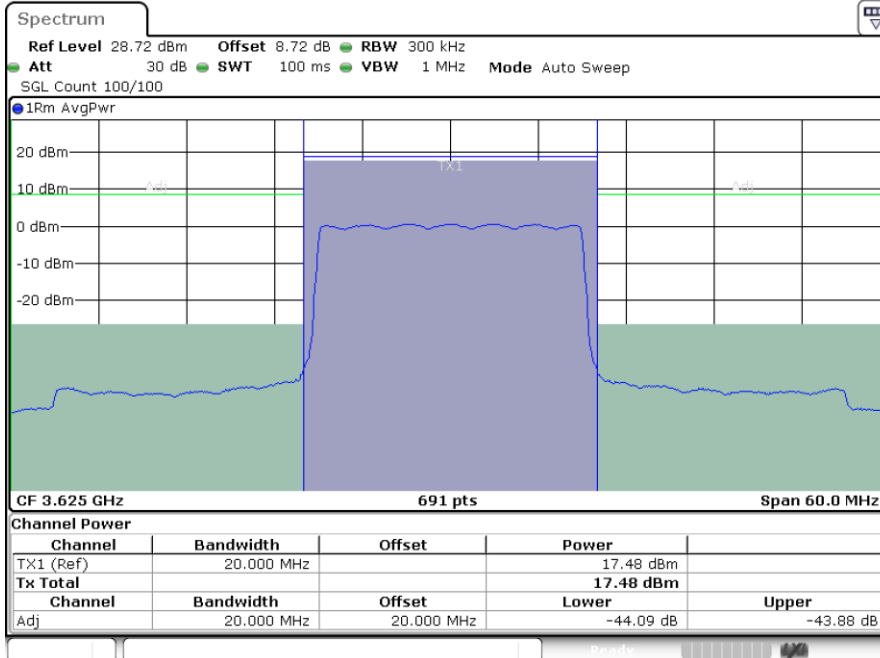

Date: 23.NOV.2021 04:35:28



LTE Band 48 / 20MHz

QPSK

Highest Channel / 1RB0

Highest Channel / 1RBmax

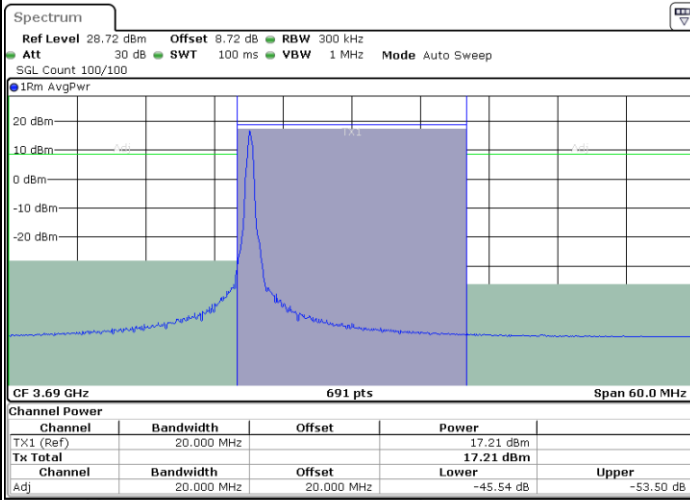

Date: 23.NOV.2021 05:13:06

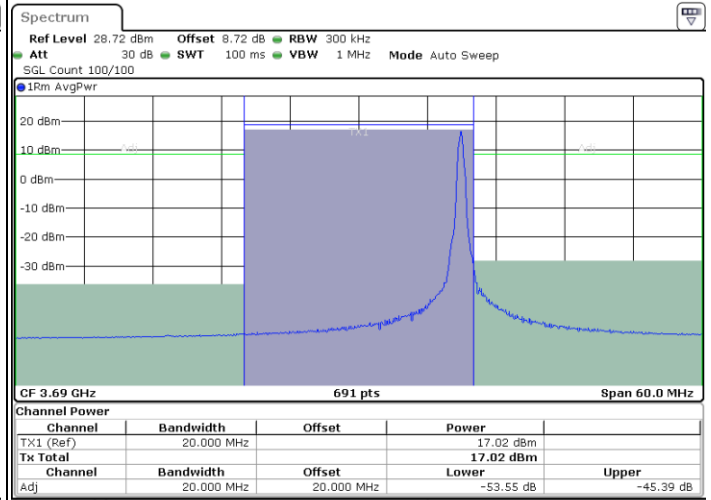

Date: 23.NOV.2021 05:27:32

Highest Channel / Full RB

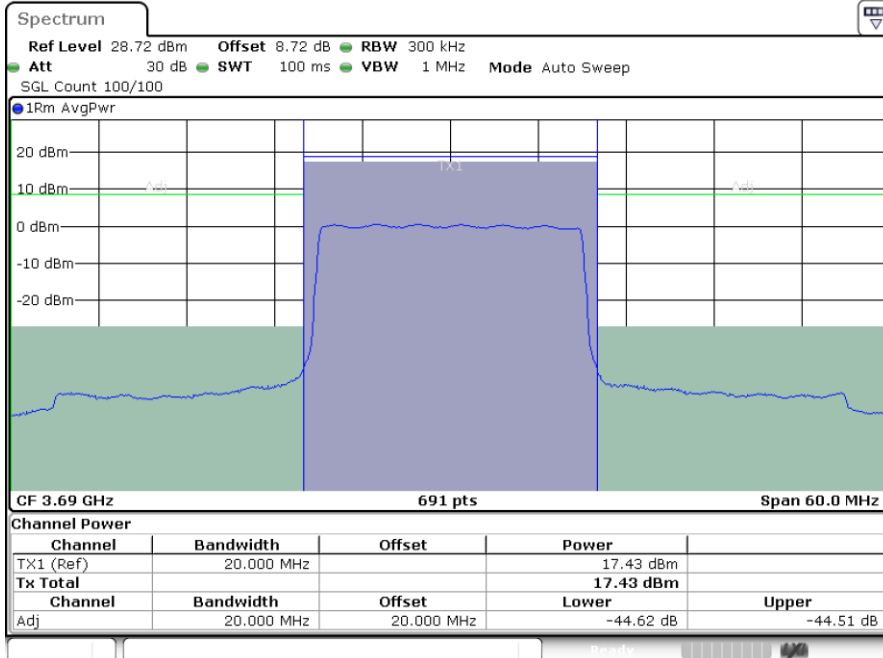

Date: 23.NOV.2021 05:31:13



LTE Band 48 / 5MHz

16QAM

Lowest Channel / 1RB0

Lowest Channel / 1RBmax

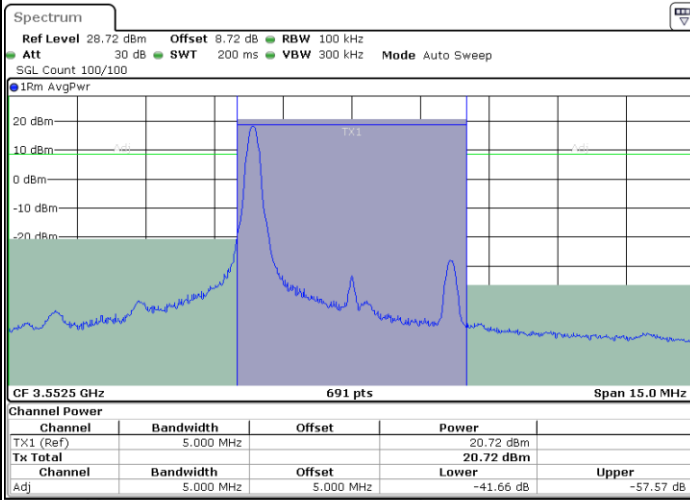

Date: 22.NOV.2021 22:48:04

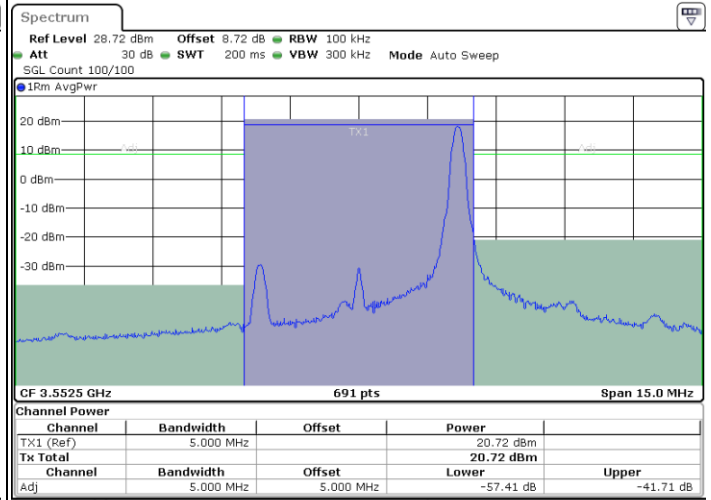

Date: 22.NOV.2021 22:55:05

Lowest Channel / Full RB

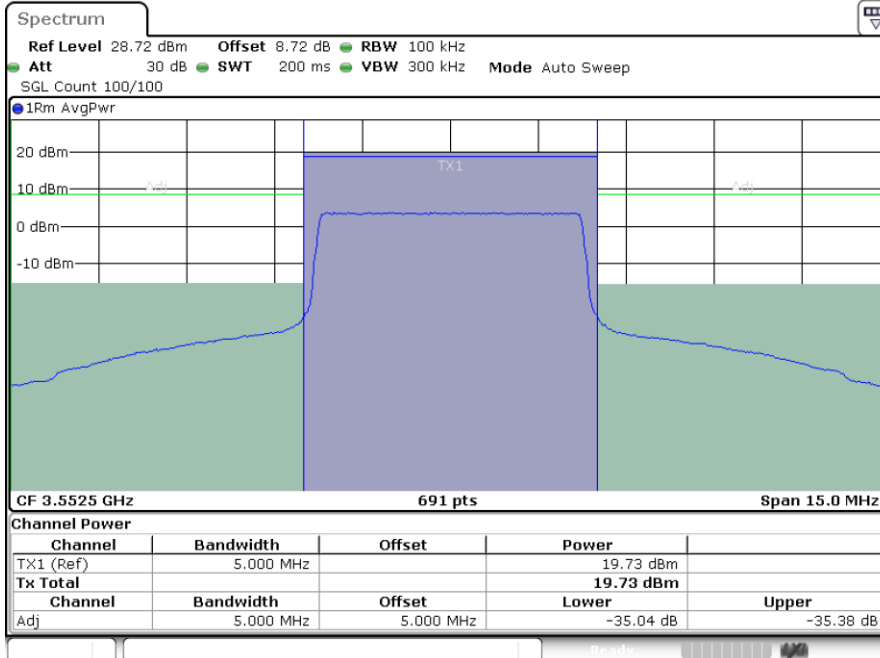

Date: 22.NOV.2021 23:01:06



LTE Band 48 / 5MHz

16QAM

Middle Channel / 1RB0

Middle Channel / 1RBmax

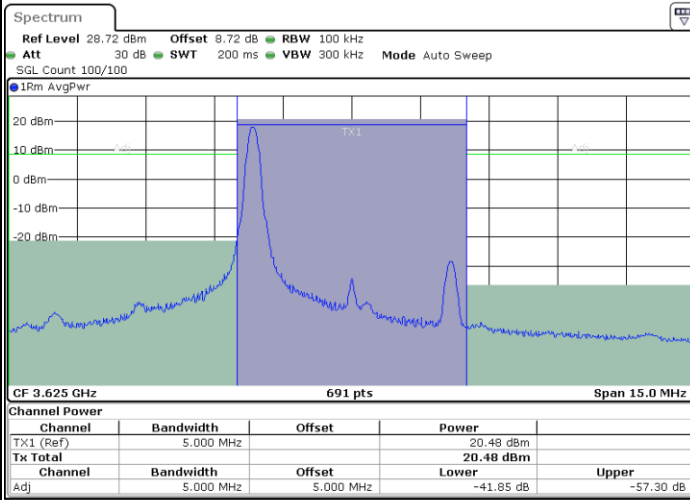

Date: 22.NOV.2021 23:49:09

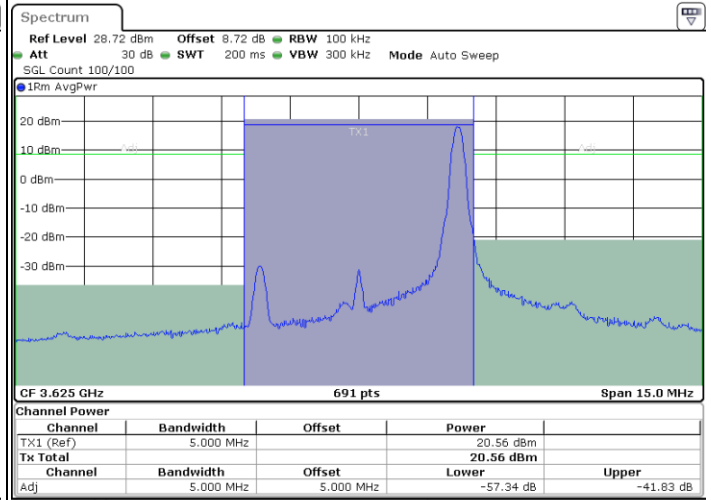

Date: 23.NOV.2021 00:03:12

Middle Channel / Full RB

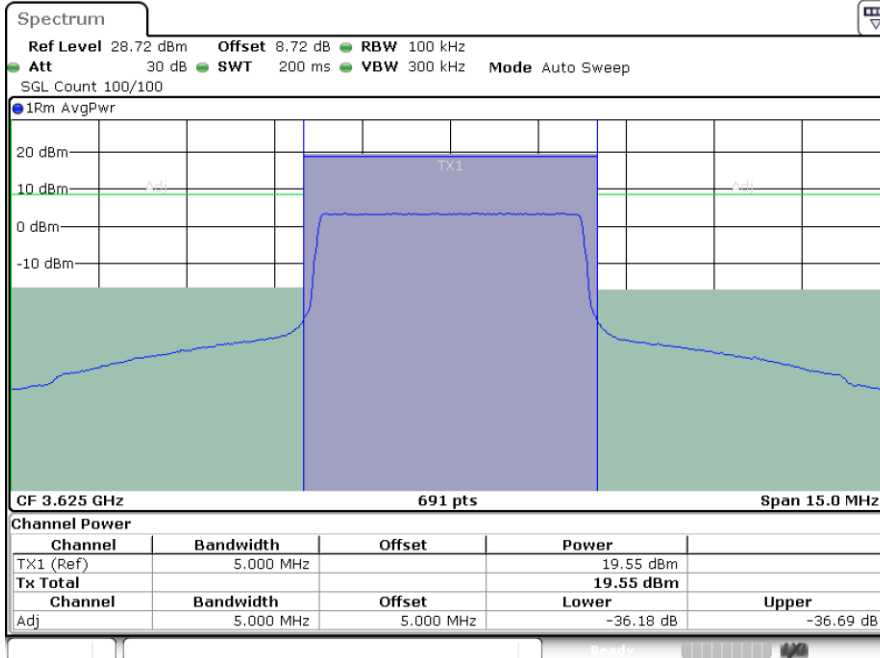

Date: 22.NOV.2021 23:44:28



LTE Band 48 / 5MHz

16QAM

Highest Channel / 1RB0

Highest Channel / 1RBmax

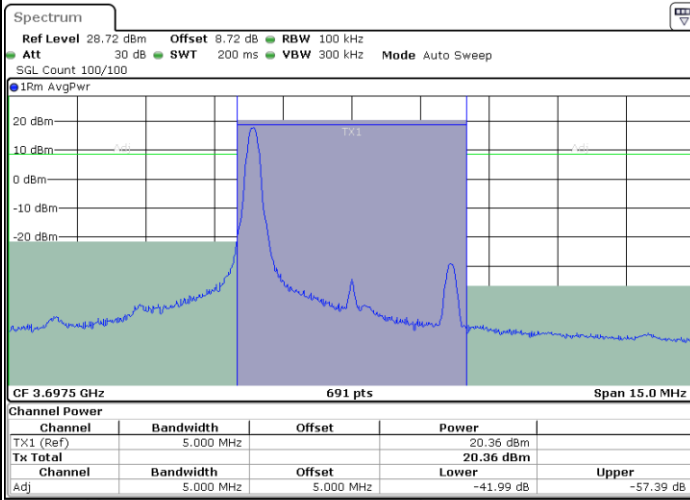

Date: 23.NOV.2021 00:09:09

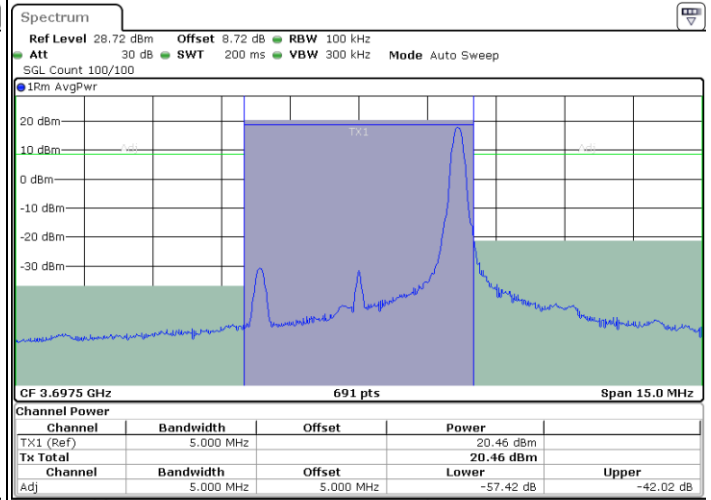

Date: 23.NOV.2021 00:27:56

Highest Channel / Full RB

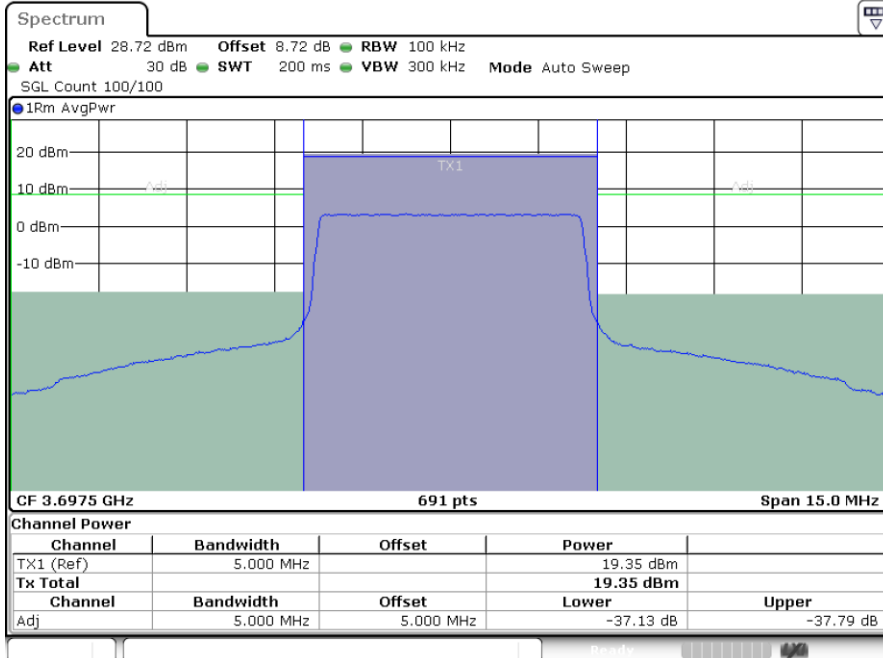

Date: 23.NOV.2021 00:34:08





LTE Band 48 / 10MHz

16QAM

Lowest Channel / 1RB0

Lowest Channel / 1RBmax

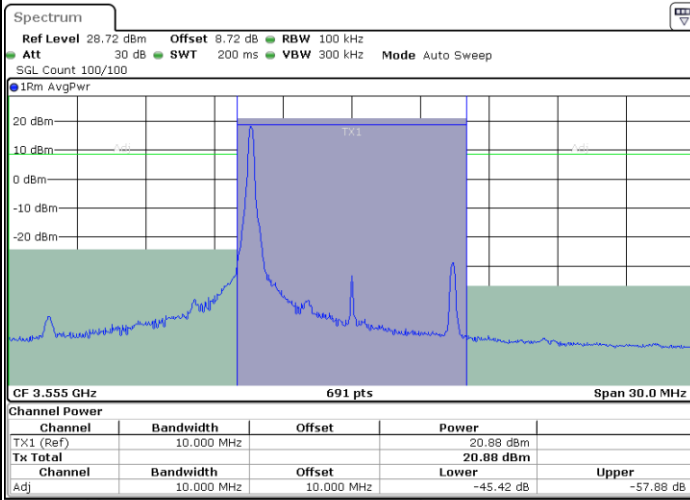

Date: 23.NOV.2021 00:42:04

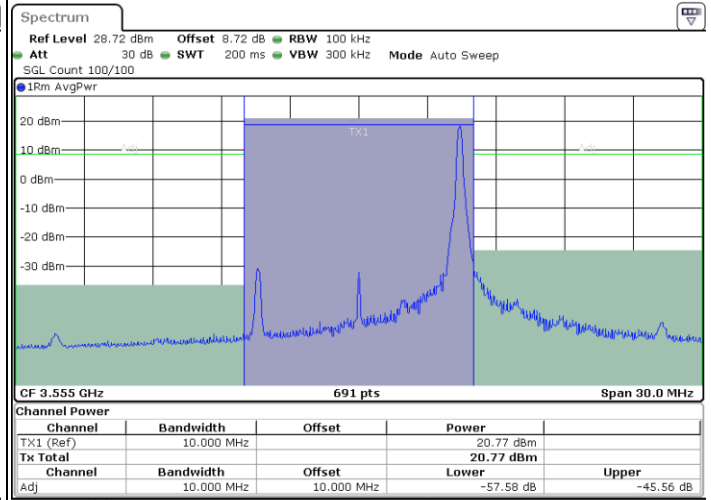

Date: 23.NOV.2021 00:51:33

Lowest Channel / Full RB

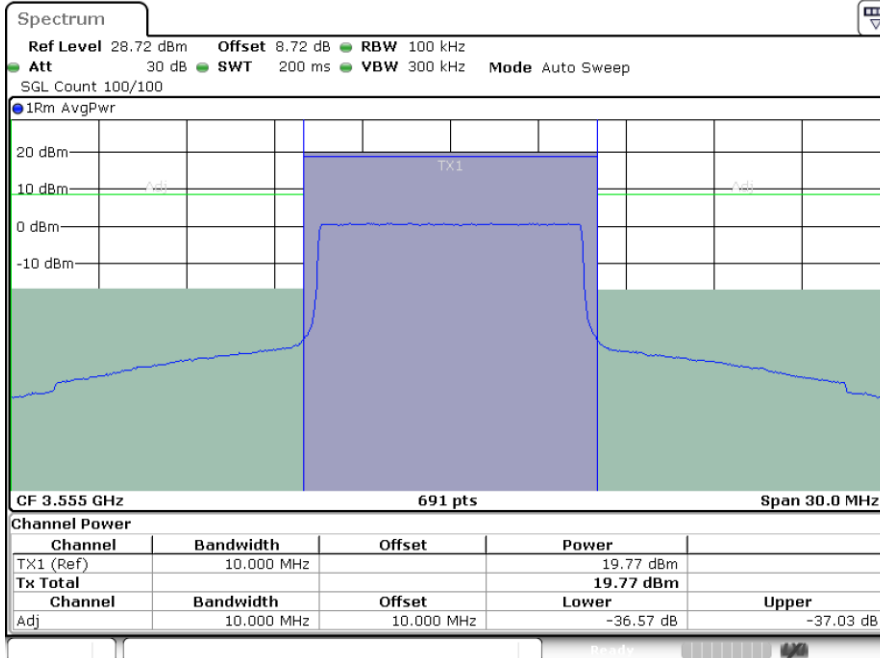

Date: 23.NOV.2021 00:56:41



LTE Band 48 / 10MHz

16QAM

MiddleChannel / 1RB0

Middle Channel / 1RBmax

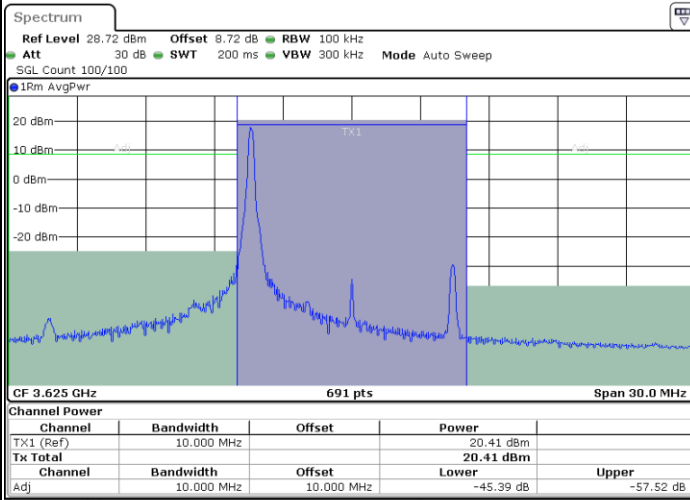

Date: 23.NOV.2021 01:05:51

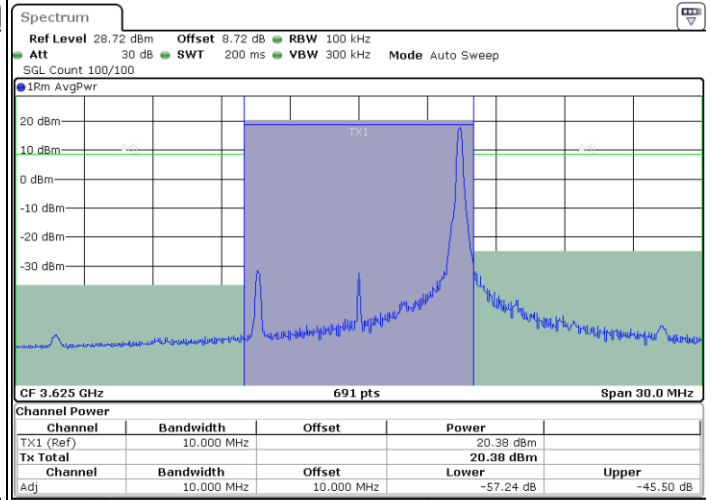

Date: 23.NOV.2021 01:13:42

Middle Channel / Full RB

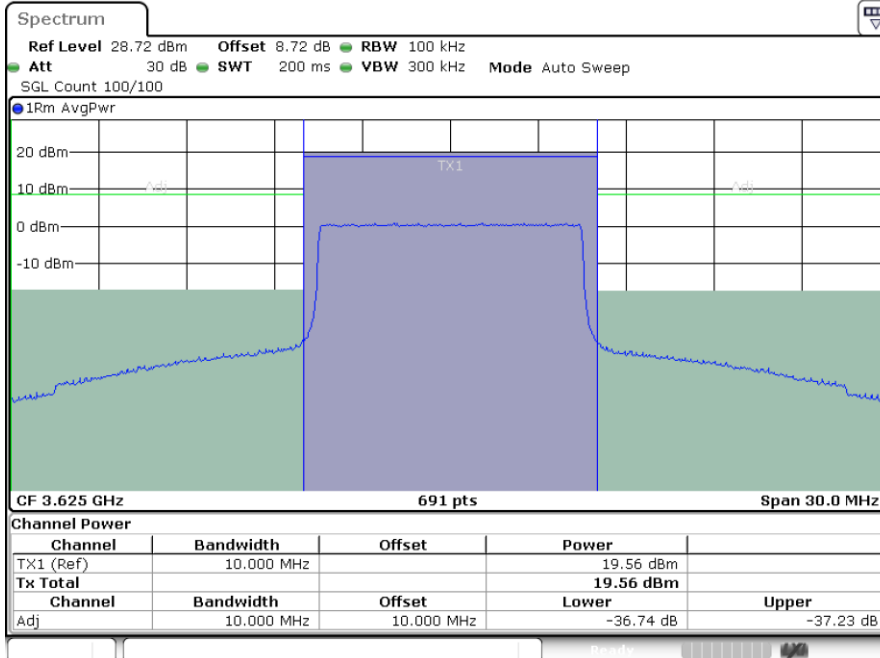

Date: 23.NOV.2021 01:24:14



LTE Band 48 / 10MHz

16QAM

Highest Channel / 1RB0

Highest Channel / 1RBmax

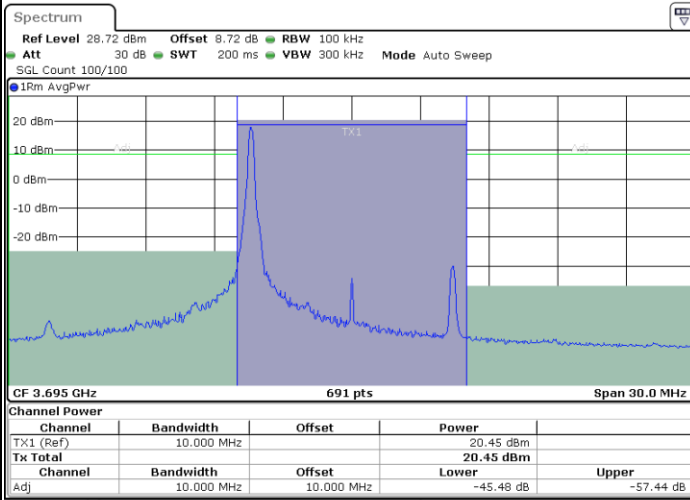

Date: 23.NOV.2021 01:30:48

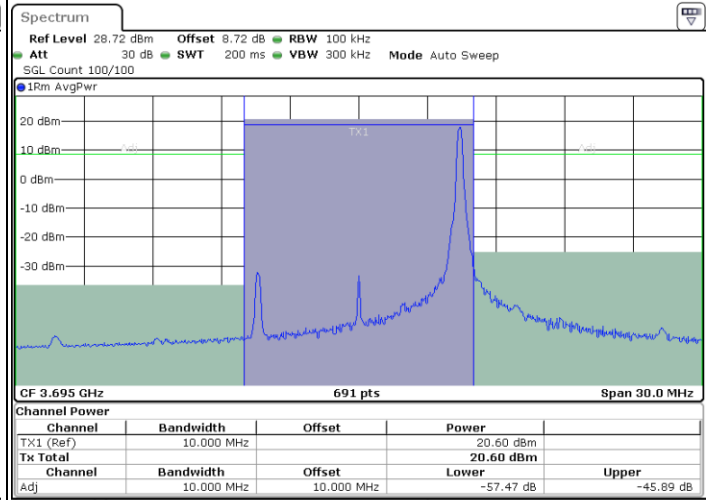

Date: 23.NOV.2021 01:41:51

Highest Channel / Full RB

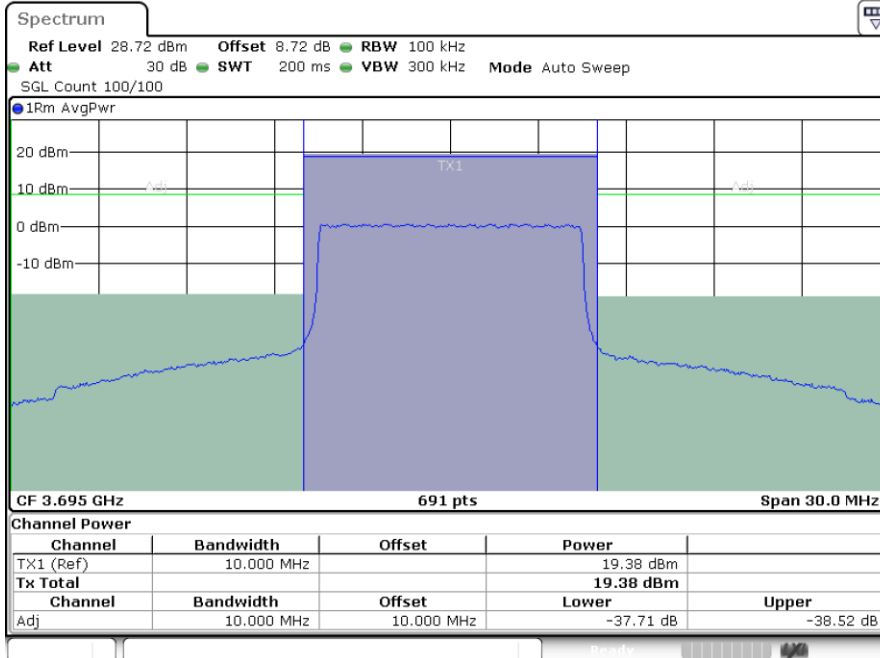

Date: 23.NOV.2021 01:53:49



LTE Band 48 / 15MHz

16QAM

Lowest Channel / 1RB0

Lowest Channel / 1RBmax

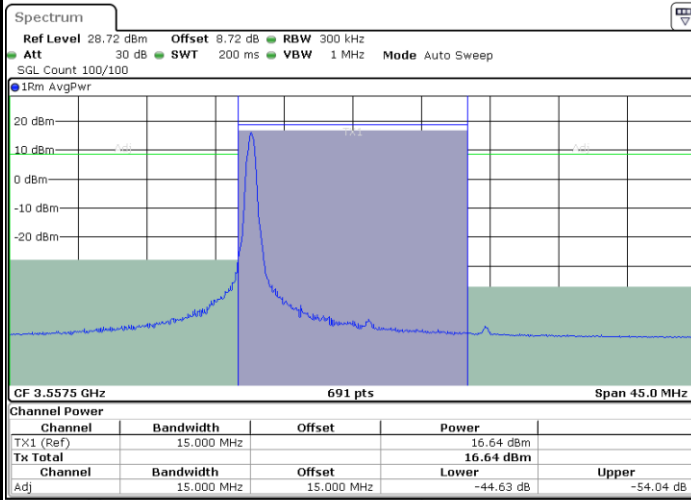

Date: 23.NOV.2021 02:32:28

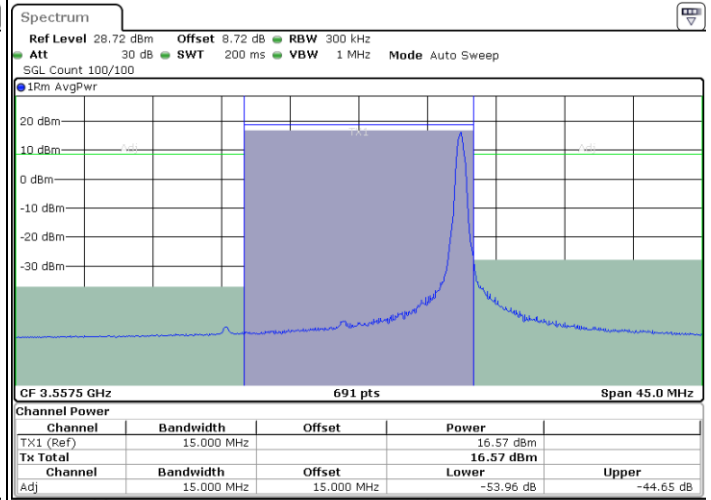

Date: 23.NOV.2021 02:36:05

Lowest Channel / Full RB

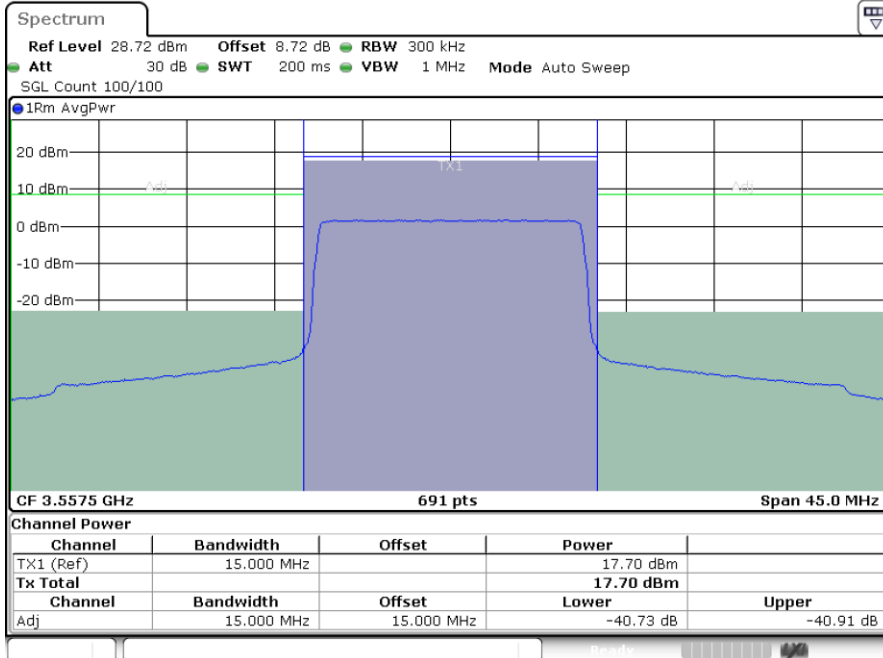

Date: 23.NOV.2021 02:38:54



LTE Band 48 / 15MHz

16QAM

Middle Channel / 1RB0

Middle Channel / 1RBmax

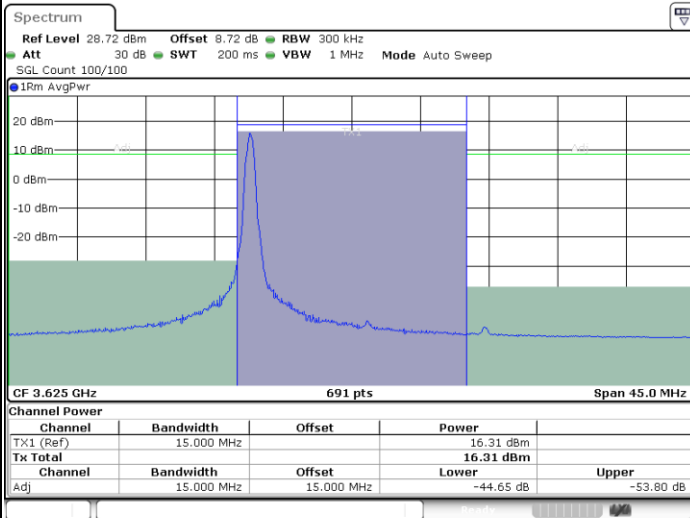

Date: 23.NOV.2021 02:43:40

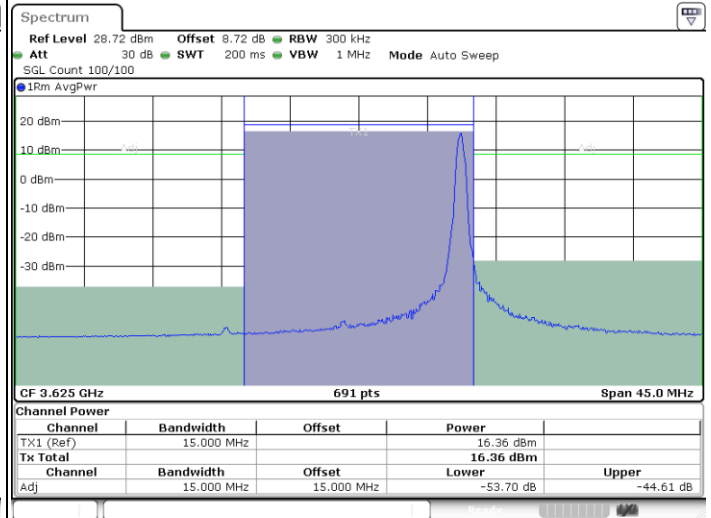

Date: 23.NOV.2021 03:16:26

Middle Channel / Full RB

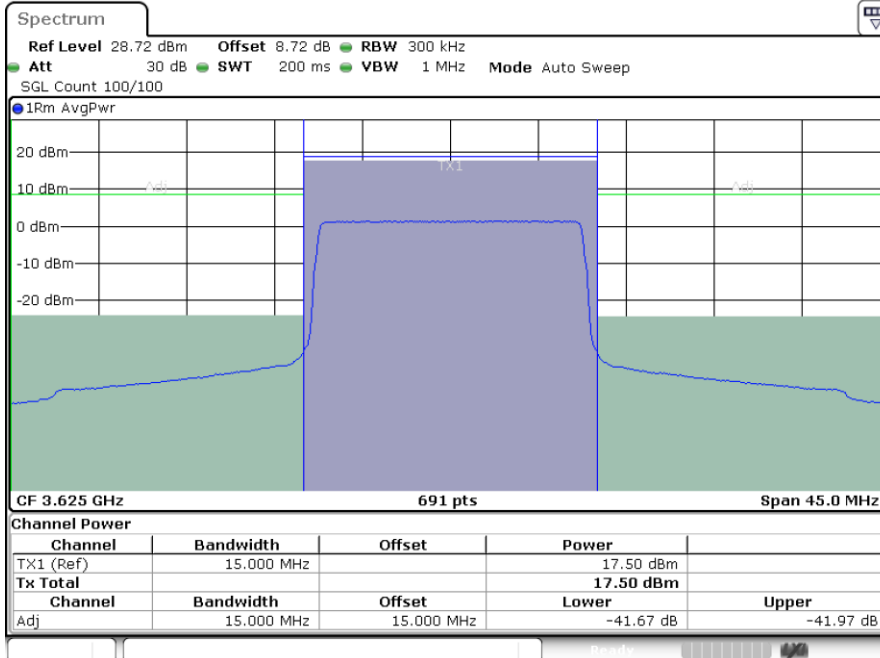

Date: 23.NOV.2021 03:21:40



LTE Band 48 / 15MHz

16QAM

Highest Channel / 1RB0

Highest Channel / 1RBmax

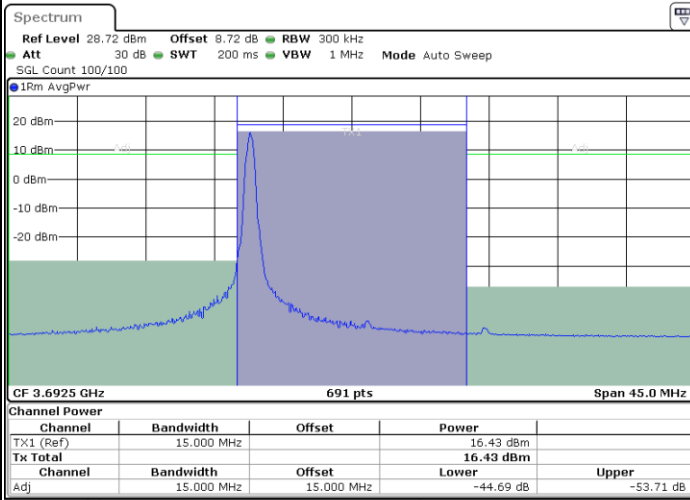

Date: 23.NOV.2021 03:29:22

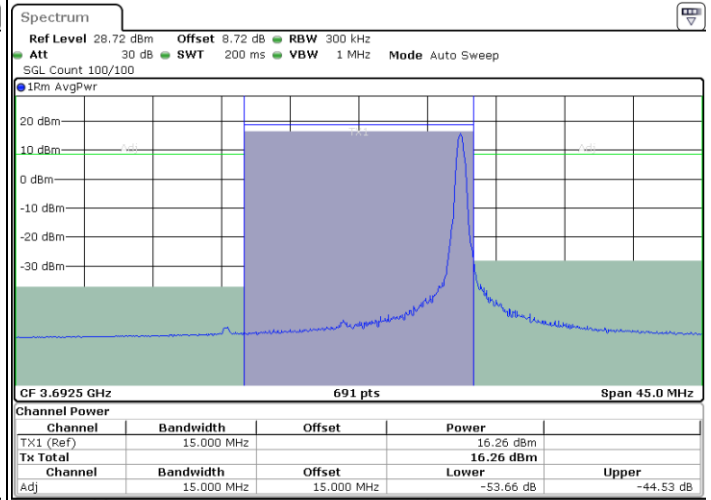

Date: 23.NOV.2021 03:43:55

Highest Channel / Full RB

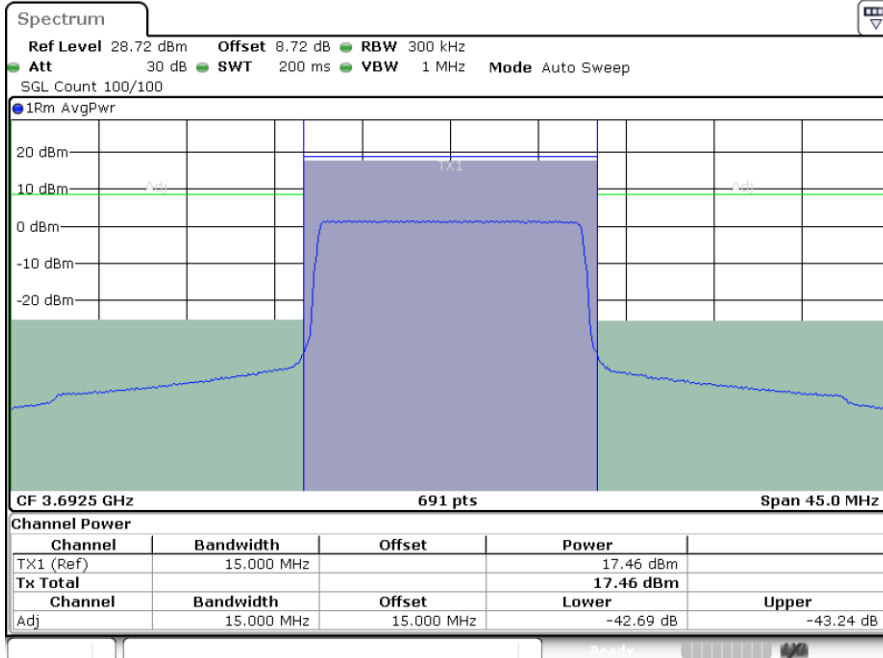

Date: 23.NOV.2021 03:50:37



LTE Band 48 / 20MHz

16QAM

Lowest Channel / 1RB0

Lowest Channel / 1RBmax

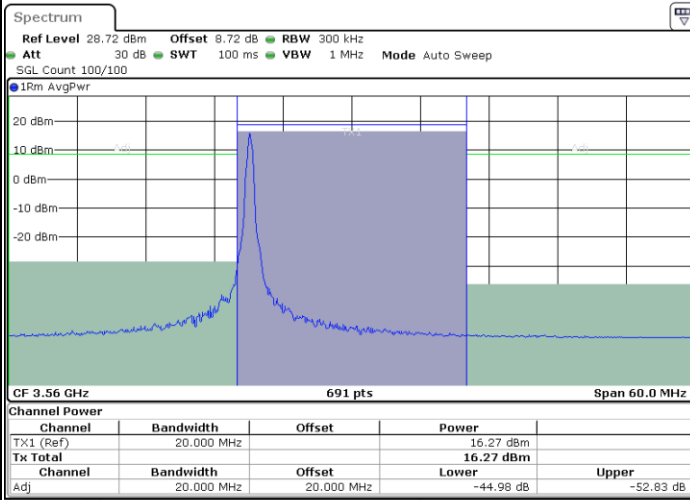

Date: 23.NOV.2021 03:59:27

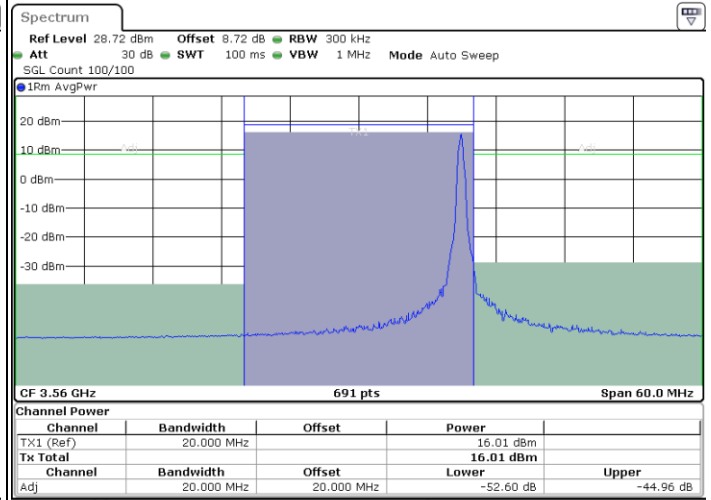

Date: 23.NOV.2021 04:08:05

Lowest Channel / Full RB

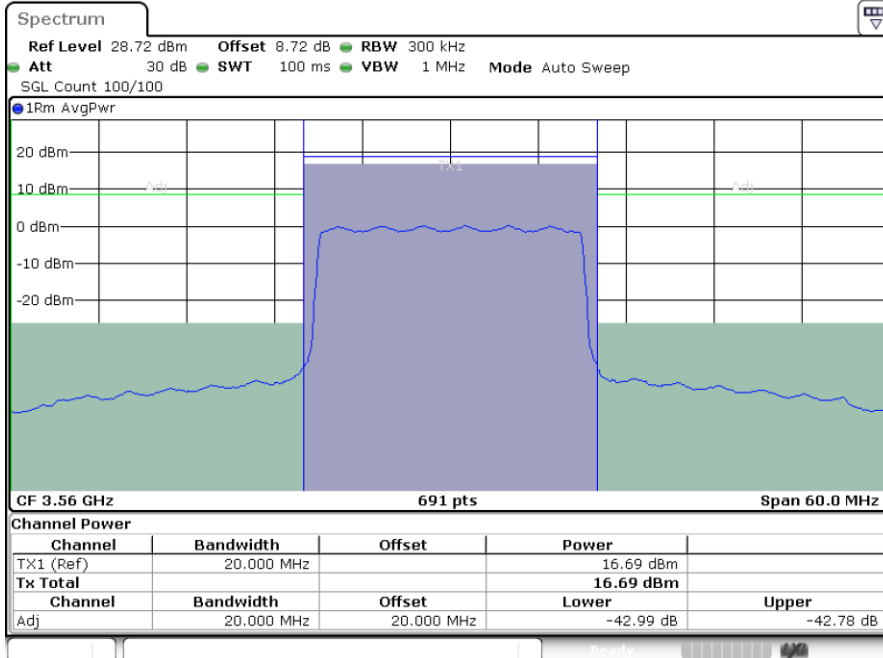

Date: 23.NOV.2021 04:14:59