



FCC RF Test Report

APPLICANT : Xiaomi Communications Co., Ltd.
EQUIPMENT : Mobile Phone
BRAND NAME : Xiaomi
MODEL NAME : 2201122G
FCC ID : 2AFZZ122G
STANDARD : 47 CFR Part 2, 27(O)
CLASSIFICATION : PCS Licensed Transmitter Held to Ear (PCE)
TEST DATE(S) : Nov. 26, 2021 ~ Dec. 11, 2021

We, Sporton International (Kunshan) Inc., would like to declare that the tested sample has been evaluated in accordance with the procedures given in ANSI C63.26-2015 and shown compliance with the applicable technical standards.

The test results in this report apply exclusively to the tested model / sample. Without written approval of Sporton International (Kunshan) Inc., the test report shall not be reproduced except in full.

Reviewed by: Jason Jia / Supervisor

Approved by: Alex Wang / Manager



Sporton International (Kunshan) Inc.

**No. 1098, Pengxi North Road, Kunshan Economic Development Zone Jiangsu Province 215300
People's Republic of China**



TABLE OF CONTENTS

REVISION HISTORY...3
SUMMARY OF TEST RESULT ...4
1 GENERAL DESCRIPTION ...5
1.1 Applicant...5
1.2 Manufacturer...5
1.3 Product Feature of Equipment Under Test...5
1.4 Product Specification of Equipment Under Test...5
1.5 Modification of EUT ...6
1.6 Maximum EIRP Power and Emission Designator ...6
1.7 Testing Location ...7
1.8 Test Software...7
1.9 Applicable Standards...7
2 TEST CONFIGURATION OF EQUIPMENT UNDER TEST ...8
2.1 Test Mode...8
2.2 Connection Diagram of Test System...10
2.3 Support Unit used in test configuration and system...10
2.4 Measurement Results Explanation Example...10
2.5 Frequency List of Low/Middle/High Channels ...11
3 CONDUCTED TEST ITEMS ...13
3.1 Measuring Instruments ...13
3.2 Test Setup ...13
3.3 Test Result of Conducted Test...13
3.4 Conducted Output Power and EIRP ...14
3.5 Peak-to-Average Ratio ...15
3.6 Occupied Bandwidth...16
3.7 Conducted Band Edge ...17
3.8 Conducted Spurious Emission ...18
3.9 Frequency Stability ...19
4 RADIATED TEST ITEMS ...20
4.1 Measuring Instruments ...20
4.2 Test Setup ...20
4.3 Test Result of Radiated Test...21
4.4 Radiated Spurious Emission ...22
5 LIST OF MEASURING EQUIPMENT ...23
6 UNCERTAINTY OF EVALUATION ...24
APPENDIX A. TEST RESULTS OF CONDUCTED TEST
APPENDIX B. TEST RESULTS OF RADIATED TEST
APPENDIX C. TEST SETUP PHOTOGRAPHS



REVISION HISTORY

REPORT NO.	VERSION	DESCRIPTION	ISSUED DATE
FG1017011	Rev. 01	Initial issue of report	Dec. 20, 2021



SUMMARY OF TEST RESULT

Report Section	FCC Rule	Description	Limit	Result	Remark
3.4	§2.1046	Conducted Output Power	Reporting Only	PASS	-
	§27.50(j)(3)	Equivalent Isotropic Radiated Power (5G NR n77, n78)	EIRP < 1Watt		
3.5	§27.50(j)(4)	Peak-to-Average Ratio	<13 dB	PASS	-
3.6	§2.1049	Occupied Bandwidth	Reporting Only	PASS	-
3.7	§2.1051 §27.53(l)(2)	Conducted Band Edge Measurement (5G NR n77, n78)	< 43+10log10(P[Watts])	PASS	-
3.8	§2.1051 §27.53(l)(2)	Conducted Spurious Emission (5G NR n77, n78)	< 43+10log10(P[Watts])	PASS	-
3.9	§2.1055 §27.54	Frequency Stability Temperature & Voltage	Within Authorized Band	PASS	-
4.4	§2.1053 §27.53(l)(2)	Radiated Spurious Emission (5G NR n77, n78)	< 43+10log ₁₀ (P[Watts])	PASS	Under limit 40.75 dB at 11376.000 MHz

Declaration of Conformity:
The test results with all measurement uncertainty excluded are presented in accordance with the regulation limits or requirements declared by manufacturers.

Comments and Explanations:
The declared of product specification for EUT presented in the report are provided by the manufacturer, and the manufacturer takes all the responsibilities for the accuracy of product specification.



1 General Description

1.1 Applicant

Xiaomi Communications Co., Ltd.

#019, 9th Floor, Building 6, 33 Xi'erqi Middle Road, Haidian District, Beijing, China, 100085

1.2 Manufacturer

Xiaomi Communications Co., Ltd.

#019, 9th Floor, Building 6, 33 Xi'erqi Middle Road, Haidian District, Beijing, China, 100085

1.3 Product Feature of Equipment Under Test

Product Feature	
Equipment	Mobile Phone
Brand Name	Xiaomi
Model Name	2201122G
FCC ID	2AFZZ122G
IMEI Code	Conducted: 863690050059314/ 863690050059322 Radiation: 863690050059678/863690050059686
HW Version	P2.1
SW Version	MIUI 13
EUT Stage	Identical Prototype

1.4 Product Specification of Equipment Under Test

Standards-related Product Specification	
Tx Frequency	5G NR n77: 3700 MHz ~ 3980 MHz 5G NR n78: 3700 MHz ~ 3800 MHz
Rx Frequency	5G NR n77: 3700 MHz ~ 3980 MHz 5G NR n78: 3700 MHz ~ 3800 MHz
SCS	n77, n78: 30kHz
Bandwidth	n77/n78: 10MHz / 15MHz / 20MHz / 30MHz / 40MHz / 50MHz / 60MHz / 70MHz / 80MHz / 90MHz / 100MHz
Antenna Gain	<Ant.10> : 5G NR n77 : -3.0 dBi 5G NR n78 : -3.0 dBi <Ant.11> : 5G NR n77 : -4.3 dBi 5G NR n78 : -4.3 dBi <Ant.12> : 5G NR n77 : -1.8 dBi 5G NR n78 : -1.8 dBi <Ant.13> : 5G NR n77 : -4.4 dBi 5G NR n78 : -4.4 dBi



Type of Modulation	CP-OFDM: QPSK / 16QAM / 64QAM / 256QAM DFT-s-OFDM: PI/2 BPSK / QPSK / 16QAM / 64QAM / 256QAM
--------------------	-------------------------------------------------------------------------------------------------

Remark:

1. The EIRP is calculated from Output power and antenna gain, only the maximum EIRP of n77/n78 for Antenna 10 and n77/n78_UL MIMO for Antenna (10 + 11) are shown in the report.
2. 5G NR n77/n78 support UL MIMO mode, and only supports CP-OFDM modulation in UL MIMO mode.
3. 5G NR Bands support SA and NSA mode. The whole testing has assessed SA mode for n77/n78 by referring to the higher conducted power for conducted test items.
4. The EN-DC combinations declared by the manufacturer are as follows: DC_2A_n78A, DC_5A_n78A, DC_7A_n78A, DC_38A_n78A, DC_41A_n78A and DC_66A_n78A.
5. The device supports HPUE mode for 5G NR n78.

1.5 Modification of EUT

No modifications are made to the EUT during all test items.

1.6 Maximum EIRP Power and Emission Designator

5G NR n77 SA		PI/2 BPSK/QPSK		16QAM / 64QAM / 256QAM	
BW (MHz)	Frequency Range (MHz)	Maximum EIRP(W)	Emission Designator (99%OBW)	Maximum EIRP(W)	Emission Designator (99%OBW)
100	3750.00 ~ 3930.00	0.1820	97M7G7D	0.1297	98M3W7D

5G NR n78 SA		PI/2 BPSK/QPSK		16QAM / 64QAM / 256QAM	
BW (MHz)	Frequency Range (MHz)	Maximum EIRP(W)	Emission Designator (99%OBW)	Maximum EIRP(W)	Emission Designator (99%OBW)
100	3750.00	0.2388	97M7G7D	0.1758	96M5W7D

5G NR n77 UL MIMO		QPSK		16QAM / 64QAM / 256QAM	
BW (MHz)	Frequency Range (MHz)	Maximum EIRP(W)	Emission Designator (99%OBW)	Maximum EIRP(W)	Emission Designator (99%OBW)
100	3750.00 ~ 3930.00	0.2506	97M9G7D	0.1778	97M7W7D

5G NR n78 UL MIMO		QPSK		16QAM / 64QAM / 256QAM	
BW (MHz)	Frequency Range (MHz)	Maximum EIRP(W)	Emission Designator (99%OBW)	Maximum EIRP(W)	Emission Designator (99%OBW)
100	3750.00	0.3281	98M1G7D	0.2547	96M7W7D



Note: All modulations have been evaluation, only the worst test results of PSK & QAM are shown in the report

1.7 Testing Location

Sporton International (Kunshan) Inc. is accredited to ISO/IEC 17025:2017 by American Association for Laboratory Accreditation with Certificate Number 5145.02.

Test Firm	Sporton International (Kunshan) Inc.		
Test Site Location	No. 1098, Pengxi North Road, Kunshan Economic Development Zone Jiangsu Province 215300 People's Republic of China TEL : +86-512-57900158 FAX : +86-512-57900958		
Test Site No.	Sporton Site No.	FCC Designation No.	FCC Test Firm Registration No.
	03CH04-KS TH01-KS	CN1257	314309

1.8 Test Software

Item	Site	Manufacturer	Name	Version
1.	03CH04-KS	AUDIX	E3	6.2009-8-24a

1.9 Applicable Standards

According to the specifications of the manufacturer, the EUT must comply with the requirements of the following standards:

- 47 CFR Part 2, 270
- ANSI C63.26-2015
- FCC KDB 971168 D01 Power Meas License Digital Systems v03r01
- FCC KDB 412172 D01 Determining ERP and EIRP v01r01

Remark: All test items were verified and recorded according to the standards and without any deviation during the test.



2 Test Configuration of Equipment Under Test

2.1 Test Mode

Antenna port conducted and radiated test items are performed according to KDB 971168 D01 Power Meas License Digital Systems v03r01 with maximum output power.

For radiated measurement, pre-scanned in three orthogonal panels, X, Y, Z. The worst cases (Y plane) were recorded in this report.

The device is investigated from 30MHz to 10 times of fundamental signal for radiated spurious emission test under different RB size/offset and modulations in exploratory test. Subsequently, only the worst case emissions are reported.

Orthogonal Planes of EUT	X Plane	Y Plane	Z Plane
			

Test Items	5G NR	Bandwidth (MHz)								Modulation					RB #		Test Channel		
		10~20	30	40	50	60	70	80-90	100	PI/2 BPSK	QPSK	16QAM	64QAM	256QAM	1	Full	L	M	H
Max. Output Power	n77	v	v	v	v	v	v	v	v		v	v	v	v	v	v	v	v	v
	n77 UL MIMO	v	v	v	v	v	v	v	v		v	v	v	v	v	v	v	v	v
	n78	v	v	v	v	v	v	v	v		v	v	v	v	v	v	v	v	v
	n78 UL MIMO	v	v	v	v	v	v	v	v		v	v	v	v	v	v	v	v	v
Peak-to-Average Ratio	n77								v		v				v	v		v	
	n77 UL MIMO								v		v				v	v		v	
	n78								v		v				v	v		v	
	n78 UL MIMO								v		v				v	v		v	
26dB and 99% Bandwidth	n77								v		v	v	v	v		v		v	
	n77 UL MIMO								v		v	v	v	v		v		v	
	n78								v		v	v	v	v		v		v	
	n78 UL MIMO								v		v	v	v	v		v		v	
Conducted Band Edge	n77	v	v	v	v	v	v	v	v		v				v	v	v		v
	n77 UL MIMO	v	v	v	v	v	v	v	v		v				v	v	v		v
	n78	v	v	v	v	v	v	v	v		v				v	v	v		v
	n78 UL MIMO	v	v	v	v	v	v	v	v		v				v	v	v		v



Test Items	5G NR	Bandwidth (MHz)								Modulation					RB #		Test Channel		
		10~20	30	40	50	60	70	80-90	100	PI/2 BPSK	QPSK	16QAM	64QAM	256QAM	1	Full	L	M	H
Conducted Spurious Emission	n77	v	v	v	v	v	v	v	v		v				v			v	
	n77 UL MIMO	v	v	v	v	v	v	v	v		v				v			v	
	n78	v	v	v	v	v	v	v	v		v				v			v	
	n78 UL MIMO	v	v	v	v	v	v	v	v		v				v			v	
Frequency Stability	n77	v									v				v			v	
	n77 UL MIMO	v									v				v			v	
	n78	v									v				v			v	
	n78 UL MIMO	v									v				v			v	
E.R.P / E.I.R.P	n77	v	v	v	v	v	v	v	v		v	v	v	v	v	v	v	v	v
	n77 UL MIMO	v	v	v	v	v	v	v	v		v	v	v	v	v	v	v	v	v
	n78	v	v	v	v	v	v	v	v		v	v	v	v	v	v	v	v	v
	n78 UL MIMO	v	v	v	v	v	v	v	v		v	v	v	v	v	v	v	v	v
Radiated Spurious Emission	n77	Worst Case																v	
	n77 UL MIMO	Worst Case																v	
	n78	Worst Case																v	
	n78 UL MIMO	Worst Case																v	
Note	<ol style="list-style-type: none"> The mark "v" means that this configuration is chosen for testing The mark "-" means that this bandwidth is not supported. The device is investigated from 30MHz to 10 times of fundamental signal for radiated spurious emission test under different RB size/offset and modulations in exploratory test. Subsequently, only the worst case emissions are reported. Based on engineering evaluation, only the worst modulations test results are shown in the report. 																		

2.2 Connection Diagram of Test System

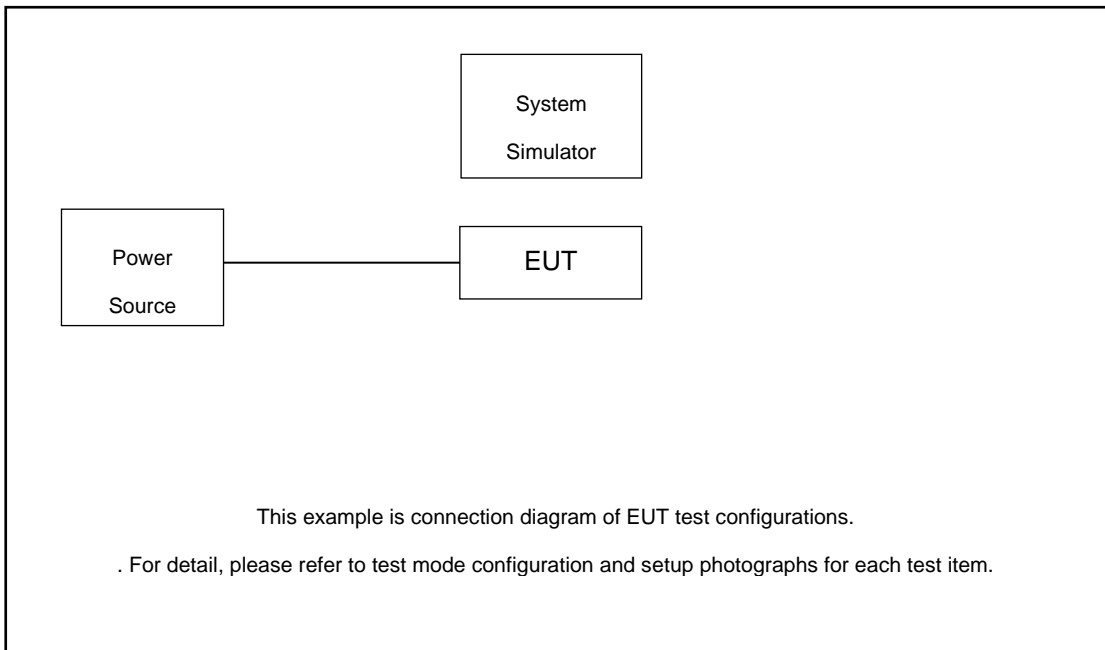

2.3 Support Unit used in test configuration and system

Item	Equipment	Trade Name	Model No.	FCC ID	Data Cable	Power Cord
1.	Power Supply	GWINSTEK	PSS-2002	N/A	N/A	Unshielded, 1.8 m
2.	LTE Base Station	Anritsu	MT8821C	N/A	N/A	Unshielded, 1.8 m
3.	NR Base Station	Anritsu	MT8000A	N/A	N/A	Unshielded, 1.8 m

2.4 Measurement Results Explanation Example

For all conducted test items:

The offset level is set in the spectrum analyzer to compensate the RF cable loss between EUT conducted output port and spectrum analyzer. With the offset compensation, the spectrum analyzer reading level is exactly the EUT RF output level.

The spectrum analyzer offset is derived from RF cable loss.

Offset = RF cable loss.

Following shows an offset computation example with cable loss 6.5 dB.

Example :

$$\text{Offset(dB)} = \text{RF cable loss(dB)} \\ = -6.5 \text{ (dB)}$$



2.5 Frequency List of Low/Middle/High Channels

5G NR n77 Channel and Frequency List				
BW [MHz]	Channel/Frequency(MHz)	Lowest	Middle	Highest
100	Channel	650000	656000	662000
	Frequency	3750	3840	3930
90	Channel	649668	656000	662332
	Frequency	3745.02	3840	3934.98
80	Channel	649334	656000	662666
	Frequency	3740.01	3840	3939.99
70	Channel	649000	656000	663000
	Frequency	3735	3840	3945
60	Channel	648668	656000	663332
	Frequency	3730.02	3840	3949.98
50	Channel	648334	656000	663666
	Frequency	3725.01	3840	3954.99
40	Channel	648000	656000	664000
	Frequency	3720	3840	3960
30	Channel	647668	656000	664332
	Frequency	3715.02	3840	3964.98
20	Channel	647334	656000	664666
	Frequency	3710.01	3840	3969.99
15	Channel	647168	656000	664832
	Frequency	3707.52	3840	3972.5
10	Channel	647000	656000	665000
	Frequency	3705	3840	3975



5G NR n78 Channel and Frequency List				
BW [MHz]	Channel/Frequency(MHz)	Lowest	Middle	Highest
100	Channel	650000		
	Frequency	3750		
90	Channel	649668	650000	650332
	Frequency	3745.02	3750	3754.98
80	Channel	649334	650000	650666
	Frequency	3740.01	3750	3759.99
70	Channel	649000	650000	651000
	Frequency	3735	3750	3765
60	Channel	648668	650000	651332
	Frequency	3730.02	3750	3769.98
50	Channel	648334	650000	651666
	Frequency	3725.01	3750	3774.99
40	Channel	648000	650000	652000
	Frequency	3720	3750	3780
30	Channel	647668	650000	652332
	Frequency	3715.02	3750	3784.98
20	Channel	647334	650000	652666
	Frequency	3710.01	3750	3789.99
15	Channel	647168	650000	652834
	Frequency	3707.52	3750	3792.51
10	Channel	647000	650000	653000
	Frequency	3705	3750	3795

3 Conducted Test Items

3.1 Measuring Instruments

See list of measuring instruments of this test report.

3.2 Test Setup

3.2.1 Conducted Output Power

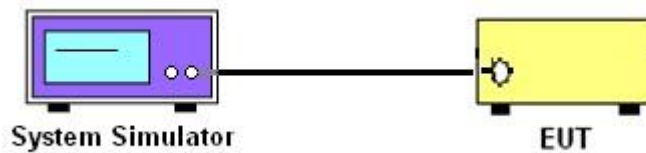

3.2.2 Peak-to-Average Ratio, Occupied Bandwidth ,Conducted Band-Edge and Conducted Spurious Emission

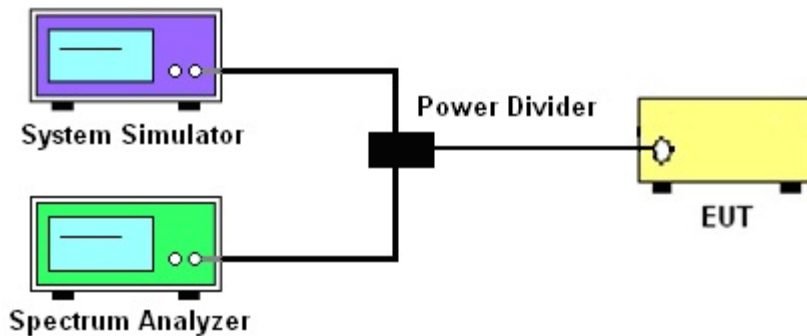

3.2.3 Frequency Stability

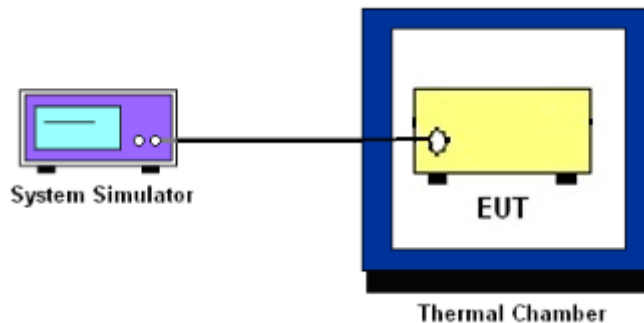

3.3 Test Result of Conducted Test

Please refer to Appendix A.



3.4 Conducted Output Power and EIRP

3.4.1 Description of the Conducted Output Power Measurement and EIRP Measurement

A system simulator was used to establish communication with the EUT. Its parameters were set to force the EUT transmitting at maximum output power. The measured power in the radio frequency on the transmitter output terminals shall be reported.

The EIRP of mobile transmitters must not exceed 1 Watts for 5G NR n77, n78.

According to KDB 412172 D01 Power Approach,

$EIRP = P_T + G_T - L_C$, $ERP = EIRP - 2.15$, where

P_T = transmitter output power in dBm

G_T = gain of the transmitting antenna in dBi

L_C = signal attenuation in the connecting cable between the transmitter and antenna in dB

3.4.2 Test Procedures

1. The testing follows ANSI C63.26 Section 5.2
2. The transmitter output port was connected to the system simulator.
3. Set EUT at maximum power through the system simulator.
4. Select lowest, middle, and highest channels for each band and different modulation.
5. Measure and record the power level from the system simulator.



3.5 Peak-to-Average Ratio

3.5.1 Description of the PAR Measurement

Power Complementary Cumulative Distribution Function (CCDF) curves provide a means for characterizing the power peaks of a digitally modulated signal on a statistical basis. A CCDF curve depicts the probability of the peak signal amplitude exceeding the average power level. Most contemporary measurement instrumentation include the capability to produce CCDF curves for an input signal provided that the instrument's resolution bandwidth can be set wide enough to accommodate the entire input signal bandwidth. In measuring transmissions in this band using an average power technique, the peak-to-average ratio (PAR) of the transmission may not exceed 13 dB.

3.5.2 Test Procedures

1. The testing follows ANSI C63.26 Section 5.2.6 (PAPR).
2. The EUT was connected to spectrum and system simulator via a power divider.
3. Set EUT in maximum power output.
4. Set the RBW = 1MHz, VBW = 3MHz, Detector = Peak, Trace mode = max hold, Set span $\geq 2 \times$ OBW in spectrum analyzer.
5. Set the RBW = 1MHz, VBW = 3MHz, Detector = power averaging, Trace mode = max hold, Set span $\geq 2 \times$ OBW in spectrum analyzer.
6. Add $[10 \log (1/\text{duty cycle})]$ to the measured maximum power level to compute the average power during continuous transmission.
7. $\text{PAPR (dB)} = P_{Pk} \text{ (dBm)} - P_{Avg} \text{ (dBm)}$
where
PAPR peak-to-average power ratio, in dB
 P_{Pk} measured peak power level, in dBm
 P_{Avg} measured average power level, in dBm
8. Record the deviation as Peak to Average Ratio.



3.6 Occupied Bandwidth

3.6.1 Description of Occupied Bandwidth Measurement

The occupied bandwidth is the width of a frequency band such that, below the lower and above the upper frequency limits, the mean powers emitted are each equal to a specified percentage 0.5% of the total mean transmitted power.

The 26 dB emission bandwidth is defined as the frequency range between two points, one above and one below the carrier frequency, at which the spectral density of the emission is attenuated 26 dB below the maximum in-band spectral density of the modulated signal. Spectral density (power per unit bandwidth) is to be measured with a detector of resolution bandwidth equal to approximately 1.0% of the emission bandwidth.

3.6.2 Test Procedures

1. The testing follows ANSI C63.26 Section 5.4
2. The EUT was connected to spectrum analyzer and system simulator via a power divider.
3. The spectrum analyzer center frequency is set to the nominal EUT channel center frequency. The span range for the spectrum analyzer shall be between two and five times the anticipated OBW.
4. The nominal resolution bandwidth (RBW) shall be in the range of 1 to 5 % of the anticipated OBW, and the VBW shall be at least 3 times the RBW.
5. Set the detection mode to peak, and the trace mode to max hold.
6. Determine the reference value: Set the EUT to transmit a modulated signal. Allow the trace to stabilize. Set the spectrum analyzer marker to the highest level of the displayed trace.
(this is the reference value)
7. Determine the “-26 dB down amplitude” as equal to (Reference Value – X).
8. Place two markers, one at the lowest and the other at the highest frequency of the envelope of the spectral display such that each marker is at or slightly below the “-X dB down amplitude” determined in step 6. If a marker is below this “-X dB down amplitude” value it shall be placed as close as possible to this value. The OBW is the positive frequency difference between the two markers.
9. Use the 99 % power bandwidth function of the spectrum analyzer and report the measured bandwidth.



3.7 Conducted Band Edge

3.7.1 Description of Conducted Band Edge Measurement

27.53(l)(2)

For mobile operations in the 3700-3980 MHz band, the conducted power of any emission outside the licensee's authorized bandwidth shall not exceed -13 dBm/MHz. Compliance with this paragraph is based on the use of measurement instrumentation employing a resolution bandwidth of 1 megahertz or greater. However, in the 1 megahertz bands immediately outside and adjacent to the licensee's frequency block, the minimum resolution bandwidth for the measurement shall be either one percent of the emission bandwidth of the fundamental emission of the transmitter or 350 kHz. In the bands between 1 and 5 MHz removed from the licensee's frequency block, the minimum resolution bandwidth for the measurement shall be 500 kHz.

3.7.2 Test Procedures

1. The testing follows ANSI C63.26 section 5.7
2. The EUT was connected to spectrum analyzer and system simulator via a power divider.
3. The band edges of low and high channels for the highest RF powers were measured.
4. Set RBW \geq 1% EBW in the 1MHz band immediately outside and adjacent to the band edge.
5. Beyond the 1 MHz band from the band edge, RBW=1MHz was used.
6. Set spectrum analyzer with RMS detector.
7. The RF fundamental frequency should be excluded against the limit line in the operating frequency band.
8. Checked that all the results comply with the emission limit line.

Example:

$$\begin{aligned} & \text{The limit line is derived from } 43 + 10\log(P)\text{dB below the transmitter power } P(\text{Watts}) \\ & = P(\text{W}) - [43 + 10\log(P)] \text{ (dB)} \\ & = [30 + 10\log(P)] \text{ (dBm)} - [43 + 10\log(P)] \text{ (dB)} = -13\text{dBm}. \end{aligned}$$



3.8 Conducted Spurious Emission

3.8.1 Description of Conducted Spurious Emission Measurement

The power of any emission outside of the authorized operating frequency ranges must be lower than the transmitter power (P) by a factor of at least $43 + 10 \log (P)$ dB.

It is measured by means of a calibrated spectrum analyzer and scanned from 30 MHz up to a frequency including its 10th harmonic.

3.8.2 Test Procedures

1. The testing follows ANSI C63.26 section 5.7
2. The EUT was connected to spectrum analyzer and system simulator via a power divider.
3. The RF output of EUT was connected to the spectrum analyzer by RF cable and attenuator. The path loss was compensated to the results for each measurement.
4. The middle channel for the highest RF power within the transmitting frequency was measured.
5. The conducted spurious emission for the whole frequency range was taken.
6. Make the measurement with the spectrum analyzer's RBW = 1MHz, VBW = 3MHz.
7. Set spectrum analyzer with RMS detector.
8. Taking the record of maximum spurious emission.
9. The RF fundamental frequency should be excluded against the limit line in the operating frequency band.
10. The limit line is derived from $43 + 10\log(P)$ dB below the transmitter power P(Watts)
= P(W)- [43 + 10log(P)] (dB)
= [30 + 10log(P)] (dBm) - [43 + 10log(P)] (dB)
= -13dBm.



3.9 Frequency Stability

3.9.1 Description of Frequency Stability Measurement

The frequency stability shall be measured by variation of ambient temperature and variation of primary supply voltage to ensure that the fundamental emission stays within the authorized frequency block. The frequency stability of the transmitter shall be maintained within $\pm 0.00025\%$ ($\pm 2.5\text{ppm}$) of the center frequency.

3.9.2 Test Procedures for Temperature Variation

1. The testing follows ANSI C63.26 section 5.6.4
2. The EUT was set up in the thermal chamber and connected with the system simulator.
3. With power OFF, the temperature was decreased to -30°C and the EUT was stabilized before testing. Power was applied and the maximum change in frequency was recorded within one minute.
4. With power OFF, the temperature was raised in 10°C step up to 50°C . The EUT was stabilized at each step for at least half an hour. Power was applied and the maximum frequency change was recorded within one minute.

3.9.3 Test Procedures for Voltage Variation

1. The testing follows ANSI C63.26 section 5.6.5
2. The EUT was placed in a temperature chamber at $20\pm 5^{\circ}\text{C}$ and connected with the system simulator.
3. The power supply voltage to the EUT was varied from 85% to 115% of the nominal value for other than hand carried battery equipment.
4. For hand carried, battery powered equipment, reduce the primary ac or dc supply voltage to the battery operating end point, which shall be specified by the manufacturer.
5. The variation in frequency was measured for the worst case.

4 Radiated Test Items

4.1 Measuring Instruments

See list of measuring instruments of this test report.

4.2 Test Setup

4.2.1 For radiated test below 30MHz

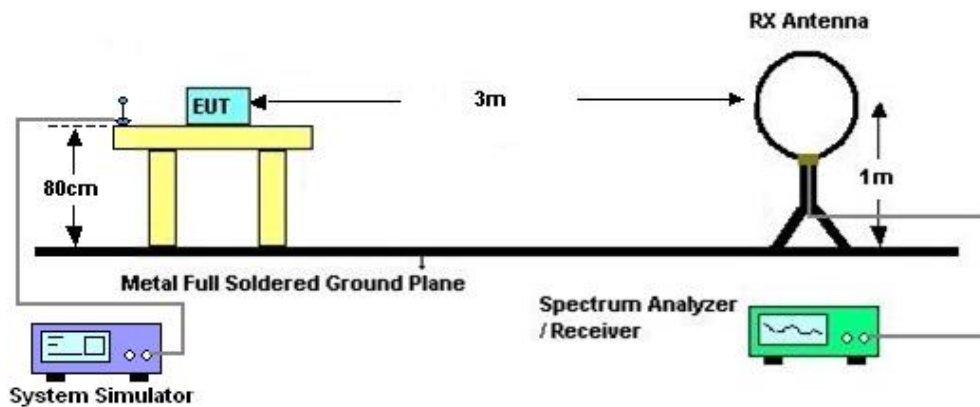

4.2.2 For radiated test from 30MHz to 1GHz

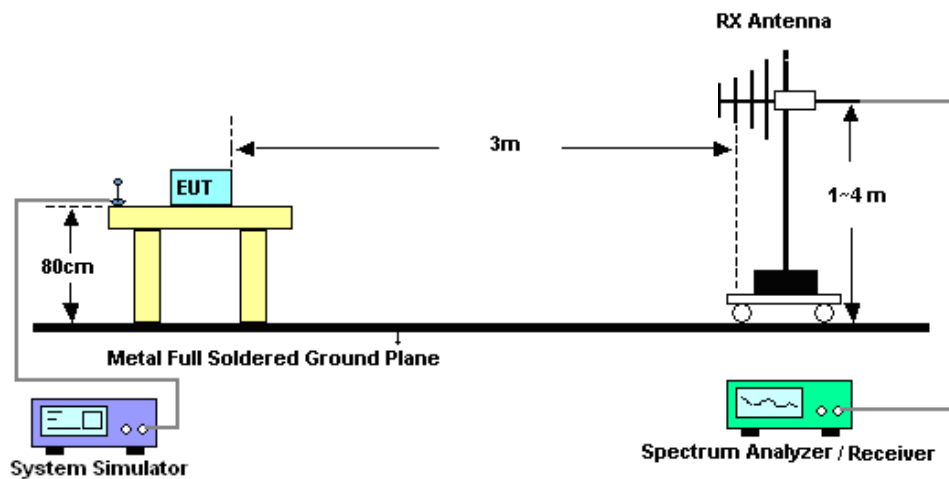

4.2.3 For radiated test above 1GHz

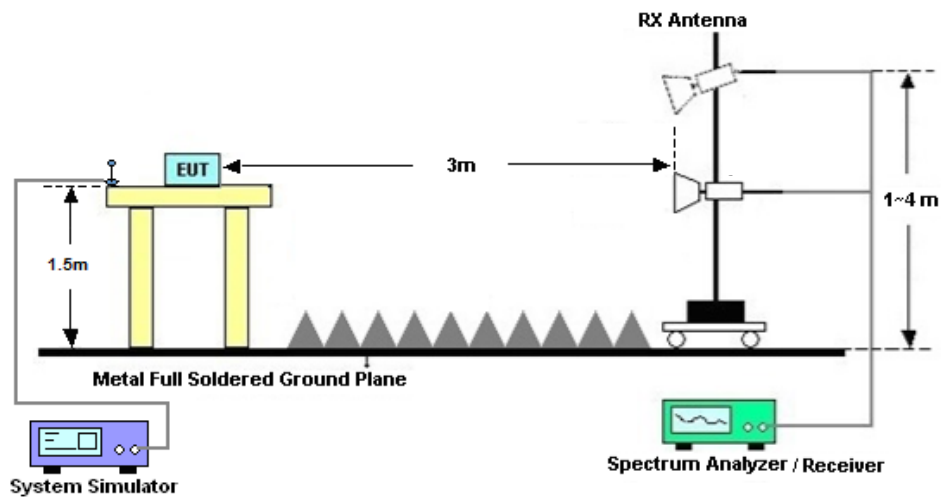

4.3 Test Result of Radiated Test

The low frequency, which started from 9 kHz to 30MHz, was pre-scanned and the result which was 20dB lower than the limit line was not reported.

Please refer to Appendix B.



4.4 Radiated Spurious Emission

4.4.1 Description of Radiated Spurious Emission

The radiated spurious emission was measured by substitution method according to ANSI C63.26. The power of any emission outside of the authorized operating frequency ranges must be attenuated below the transmitter power (P) by a factor of at least $43 + 10 \log (P)$ dB.

The spectrum is scanned from 30 MHz up to a frequency including its 10th harmonic.

4.4.2 Test Procedures

1. The testing follows ANSI C63.26 Section 5.5
2. The EUT was placed on a turntable with 0.8 meter height for frequency below 1GHz and 1.5 meter height for frequency above 1GHz respectively above ground.
3. The EUT was set 3 meters from the receiving antenna mounted on the antenna tower.
4. The table was rotated 360 degrees to determine the position of the highest spurious emission.
5. The height of the receiving antenna is varied between 1m to 4m to search the maximum spurious emission for both horizontal and vertical polarizations.
6. During the measurement, the system simulator parameters were set to force the EUT transmitting at maximum output power.
7. Make the measurement with the spectrum analyzer's RBW = 1MHz, VBW = 3MHz, taking the record of maximum spurious emission.
8. A horn antenna was substituted in place of the EUT and was driven by a signal generator.
9. Tune the output power of signal generator to the same emission level with EUT maximum spurious emission.
10. $EIRP (dBm) = S.G. Power - Tx Cable Loss + Tx Antenna Gain$
11. $ERP (dBm) = EIRP - 2.15$
12. The RF fundamental frequency should be excluded against the limit line in the operating frequency band.

The limit line is derived from $43 + 10\log(P)$ dB below the transmitter power P(Watts)
 $= P(W) - [43 + 10\log(P)] (dB)$
 $= [30 + 10\log(P)] (dBm) - [43 + 10\log(P)] (dB)$
 $= -13dBm.$



5 List of Measuring Equipment

Instrument	Manufacturer	Model No.	Serial No.	Characteristics	Calibration Date	Test Date	Due Date	Remark
Spectrum Analyzer	R&S	FSV40	101040	10Hz~40GHz	Oct. 14, 2021	Nov. 26, 2021~ Dec. 03, 2021	Oct. 13, 2022	Conducted (TH01-KS)
Power divider	STI	STI08-0055	-	0.5~40GHz	Aug. 26, 2021	Nov. 26, 2021~ Dec. 03, 2021	Aug. 25, 2022	Conducted (TH01-KS)
Temperature & humidity chamber	Hongzhan	LP-150U	H2014011440	-40~+150°C 20%~95%RH	Jul. 12, 2021	Nov. 26, 2021~ Dec. 03, 2021	Jul. 11, 2022	Conducted (TH01-KS)
EXA Spectrum Analyzer	Keysight	N9010A	MY55150244	10Hz-44G,MAX 30dB	Apr. 13, 2021	Dec. 11, 2021	Apr. 12, 2022	Radiation (03CH04-KS)
Loop Antenna	R&S	HFH2-Z2	100321	9kHz~30MHz	Oct. 30, 2021	Dec. 11, 2021	Oct. 29, 2022	Radiation (03CH04-KS)
Bilog Antenna	TeseQ	CBL6111D	49922	30MHz-1GHz	May 30, 2021	Dec. 11, 2021	May 29, 2022	Radiation (03CH04-KS)
Horn Antenna	Schwarzbeck	BBHA9120D	1356	1GHz~18GHz	Apr. 18, 2021	Dec. 11, 2021	Apr. 17, 2022	Radiation (03CH04-KS)
SHF-EHF Horn	Com-power	AH-840	101070	18GHz~40GHz	Jan. 06, 2021	Dec. 11, 2021	Jan. 05, 2022	Radiation (03CH04-KS)
Amplifier	SONOMA	310N	187289	9KHz-1GHz	Jan. 06, 2021	Dec. 11, 2021	Jan. 05, 2022	Radiation (03CH04-KS)
Amplifier	MITEQ	EM18G40G GA	060728	18~40GHz	Jan. 07, 2021	Dec. 11, 2021	Jan. 06, 2022	Radiation (03CH04-KS)
high gain Amplifier	MITEQ	AMF-7D-00 101800-30-1 0P	2025788	1Ghz-18Ghz	Jan. 06, 2021	Dec. 11, 2021	Jan. 05, 2022	Radiation (03CH04-KS)
Amplifier	Keysight	83017A	MY57280106	500MHz~26.5GHz	Oct. 13, 2021	Dec. 11, 2021	Oct. 12, 2022	Radiation (03CH04-KS)
AC Power Source	Chroma	61601	F104090004	N/A	NCR	Dec. 11, 2021	NCR	Radiation (03CH04-KS)
Turn Table	ChamPro	EM 1000-T	060762-T	0~360 degree	NCR	Dec. 11, 2021	NCR	Radiation (03CH04-KS)
Antenna Mast	ChamPro	EM 1000-A	060762-A	1 m~4 m	NCR	Dec. 11, 2021	NCR	Radiation (03CH04-KS)

NCR: No Calibration Required



6 Uncertainty of Evaluation

The measurement uncertainties shown below were calculated in accordance with the requirements of ANSI 63.26-2015. All the measurement uncertainty value were shown with a coverage K=2 to indicate 95% level of confidence. The measurement data show herein meets or exceeds the CISPR measurement uncertainty values specified in CISPR 16-4-2 and can be compared directly to specified limit to determine compliance.

Uncertainty of Radiated Emission Measurement (30 MHz ~ 1000 MHz)

Measuring Uncertainty for a Level of Confidence of 95% (U = 2Uc(y))	3.3dB
---------------------------------------------------------------------	-------

Uncertainty of Radiated Emission Measurement (1 GHz ~ 18 GHz)

Measuring Uncertainty for a Level of Confidence of 95% (U = 2Uc(y))	2.8dB
---------------------------------------------------------------------	-------

Uncertainty of Radiated Emission Measurement (18 GHz ~ 40 GHz)

Measuring Uncertainty for a Level of Confidence of 95% (U = 2Uc(y))	2.8dB
---------------------------------------------------------------------	-------

----- THE END -----



Appendix A. Test Results of Conducted Test

Conducted Output Power(Average power) and EIRP

n77(Ant10):

BW [MHz]	Modulation	RB Size	RB Offset	Power Low Ch. / Freq.	Power Middle Ch. / Freq.	Power High Ch. / Freq.	Gain	EIRP	EIRP	EIRP
Channel				650000	656000	662000		L	M	H
Frequency (MHz)				3750	3840	3930				
100	PI/2 BPSK	1	1	24.99	25.35	25.60	-3.0	0.1581	0.1718	0.1820
100	PI/2 BPSK	1	137	24.93	25.32	25.36	-3.0	0.1560	0.1706	0.1722
100	PI/2 BPSK	1	271	24.95	25.20	25.54	-3.0	0.1567	0.1660	0.1795
100	PI/2 BPSK	135	0	24.40	24.71	24.66	-3.0	0.1380	0.1483	0.1466
100	PI/2 BPSK	135	69	24.92	25.22	25.31	-3.0	0.1556	0.1667	0.1702
100	PI/2 BPSK	135	138	24.33	24.71	24.96	-3.0	0.1358	0.1483	0.1570
100	PI/2 BPSK	270	0	24.36	24.73	24.82	-3.0	0.1368	0.1489	0.1521
100	QPSK	1	1	24.76	25.01	25.02	-3.0	0.1500	0.1589	0.1592
100	QPSK	1	137	24.92	25.26	25.42	-3.0	0.1556	0.1683	0.1746
100	QPSK	1	271	24.96	25.14	25.41	-3.0	0.1570	0.1637	0.1742
100	QPSK	135	0	23.92	24.27	24.73	-3.0	0.1236	0.1340	0.1489
100	QPSK	135	69	24.98	25.30	25.28	-3.0	0.1578	0.1698	0.1690
100	QPSK	135	138	23.90	24.20	24.96	-3.0	0.1230	0.1318	0.1570
100	QPSK	270	0	23.88	24.29	24.82	-3.0	0.1225	0.1346	0.1521
100	16QAM	1	1	23.78	24.13	24.02	-3.0	0.1197	0.1297	0.1265
100	64QAM	1	1	21.79	22.00	21.97	-3.0	0.0757	0.0794	0.0789
100	256QAM	1	1	20.06	20.38	20.22	-3.0	0.0508	0.0547	0.0527
Channel				649668	656000	662334	Gain	EIRP	EIRP	EIRP
Frequency (MHz)				3745.02	3840	3935.01				
90	PI/2 BPSK	1	1	24.78	25.11	25.13	-3.0	0.1507	0.1626	0.1633
Channel				649334	656000	662668	Gain	EIRP	EIRP	EIRP
Frequency (MHz)				3740.01	3840	3940.02				
80	PI/2 BPSK	1	1	24.75	25.20	25.08	-3.0	0.1496	0.1660	0.1614
Channel				649000	656000	663000	Gain	EIRP	EIRP	EIRP
Frequency (MHz)				3735	3840	3945				
70	PI/2 BPSK	1	1	24.77	25.26	25.01	-3.0	0.1503	0.1683	0.1589
Channel				648668	656000	663334	Gain	EIRP	EIRP	EIRP
Frequency (MHz)				3730.02	3840	3950.01				
60	PI/2 BPSK	1	1	25.11	25.28	25.35	-3.0	0.1626	0.1690	0.1718
Channel				648334	656000	663668	Gain	EIRP	EIRP	EIRP
Frequency (MHz)				3725.01	3840	3955.02				
50	PI/2 BPSK	1	1	25.04	25.38	25.44	-3.0	0.1600	0.1730	0.1754
Channel				648000	656000	664000	Gain	EIRP	EIRP	EIRP
Frequency (MHz)				3720	3840	3960				
40	PI/2 BPSK	1	1	25.39	25.33	25.38	-3.0	0.1734	0.1710	0.1730



Channel				647668	656000	664334	Gain	EIRP	EIRP	EIRP
Frequency (MHz)				3715.02	3840	3965.01				
30	PI/2 BPSK	1	1	25.38	25.32	25.36	-3.0	0.1730	0.1706	0.1722
Channel				647334	656000	664668	Gain	EIRP	EIRP	EIRP
Frequency (MHz)				3710.01	3840	3970.02				
20	PI/2 BPSK	1	1	25.21	25.30	25.39	-3.0	0.1663	0.1698	0.1734
Channel				647168	656000	664834	Gain	EIRP	EIRP	EIRP
Frequency (MHz)				3707.52	3840	3972.51				
15	PI/2 BPSK	1	1	25.36	25.27	25.32	-3.0	0.1722	0.1687	0.1706
Channel				647000	656000	665000	Gain	EIRP	EIRP	EIRP
Frequency (MHz)				3705	3840	3975				
10	PI/2 BPSK	1	1	25.32	25.35	25.23	-3.0	0.1706	0.1718	0.1671



n78(Ant10):

BW [MHz]	Modulation	RB Size	RB Offset	Power Low Ch. / Freq.	Power Middle Ch. / Freq.	Power High Ch. / Freq.	Gain	EIRP	EIRP	EIRP
Channel				650000				L	M	H
Frequency (MHz)				3750						
100	PI/2 BPSK	1	1		26.78		-3.0		0.2388	
100	PI/2 BPSK	1	137		26.49		-3.0		0.2234	
100	PI/2 BPSK	1	271		26.37		-3.0		0.2173	
100	PI/2 BPSK	135	0		26.01		-3.0		0.2000	
100	PI/2 BPSK	135	69		26.47		-3.0		0.2223	
100	PI/2 BPSK	135	138		25.94		-3.0		0.1968	
100	PI/2 BPSK	270	0		25.96		-3.0		0.1977	
100	QPSK	1	1		26.23		-3.0		0.2104	
100	QPSK	1	137		26.40		-3.0		0.2188	
100	QPSK	1	271		26.42		-3.0		0.2198	
100	QPSK	135	0		26.46		-3.0		0.2218	
100	QPSK	135	69		26.41		-3.0		0.2193	
100	QPSK	135	138		25.42		-3.0		0.1746	
100	QPSK	270	0		25.44		-3.0		0.1754	
100	16QAM	1	1		25.45		-3.0		0.1758	
100	64QAM	1	1		23.34		-3.0		0.1081	
100	256QAM	1	1		21.78		-3.0		0.0755	
Channel				649668	650000	650334	Gain	EIRP	EIRP	EIRP
Frequency (MHz)				3745.02	3750	3755.01				
90	PI/2 BPSK	1	1	26.39	26.47	26.46	-3.0	0.2183	0.2223	0.2218
Channel				649334	650000	650668	Gain	EIRP	EIRP	EIRP
Frequency (MHz)				3740.01	3750	3760.02				
80	PI/2 BPSK	1	1	26.45	26.53	26.56	-3.0	0.2213	0.2254	0.2270
Channel				649000	650000	651000	Gain	EIRP	EIRP	EIRP
Frequency (MHz)				3735	3750	3765				
70	PI/2 BPSK	1	1	26.40	26.58	26.49	-3.0	0.2188	0.2280	0.2234
Channel				648668	650000	651334	Gain	EIRP	EIRP	EIRP
Frequency (MHz)				3730.02	3750	3770.01				
60	PI/2 BPSK	1	1	26.59	26.51	26.50	-3.0	0.2286	0.2244	0.2239
Channel				648334	650000	651668	Gain	EIRP	EIRP	EIRP
Frequency (MHz)				3725.01	3750	3775.02				
50	PI/2 BPSK	1	1	26.60	26.64	26.55	-3.0	0.2291	0.2312	0.2265
Channel				648000	650000	652000	Gain	EIRP	EIRP	EIRP
Frequency (MHz)				3720	3750	3780				
40	PI/2 BPSK	1	1	26.55	26.65	26.60	-3.0	0.2265	0.2317	0.2291
Channel				647668	650000	652334	Gain	EIRP	EIRP	EIRP
Frequency (MHz)				3715.02	3750	3785.01				
30	PI/2 BPSK	1	1	26.65	26.71	26.67	-3.0	0.2317	0.2350	0.2328
Channel				647334	650000	652668	Gain	EIRP	EIRP	EIRP
Frequency (MHz)				3710.01	3750	3790.02				
20	PI/2 BPSK	1	1	26.62	26.65	26.70	-3.0	0.2301	0.2317	0.2344



Channel				647168	650000	652834	Gain	EIRP	EIRP	EIRP
Frequency (MHz)				3707.52	3750	3792.51				
15	PI/2 BPSK	1	1	26.65	26.68	26.66	-3.0	0.2317	0.2333	0.2323
Channel				647000	650000	653000	Gain	EIRP	EIRP	EIRP
Frequency (MHz)				3705	3750	3795				
10	PI/2 BPSK	1	1	26.67	26.72	26.69	-3.0	0.2328	0.2355	0.2339



n77 UL MIMO(Ant10+ Ant11):

BW [MHz]	Modulation	RB Size	RB Offset	Power Low Ch. / Freq.	Power Middle Ch. / Freq.	Power High Ch. / Freq.	MIMO Gain	EIRP	EIRP	EIRP
Channel				650000	656000	662000		L	M	H
Frequency (MHz)				3750	3840	3930				
100	QPSK	1	1	22.58	23.98	22.81	0.01	0.1854	0.2506	0.1914
100	QPSK	1	137	22.76	23.02	23.19	0.01	0.1932	0.2009	0.2089
100	QPSK	1	272	22.70	23.10	23.39	0.01	0.1905	0.2046	0.2188
100	QPSK	135	0	21.12	21.42	21.53	0.01	0.1324	0.1390	0.1426
100	QPSK	135	69	22.71	23.05	23.28	0.01	0.1910	0.2023	0.2133
100	QPSK	135	138	21.30	21.54	21.89	0.01	0.1380	0.1429	0.1549
100	QPSK	273	0	21.19	21.51	21.76	0.01	0.1346	0.1419	0.1503
100	16QAM	1	1	22.24	22.18	22.49	0.01	0.1714	0.1656	0.1778
100	64QAM	1	1	20.42	20.68	20.82	0.01	0.1127	0.1172	0.1211
100	256QAM	1	1	17.58	18.01	18.04	0.01	0.0586	0.0634	0.0638
Channel				649668	656000	662334	MIMO Gain	EIRP	EIRP	EIRP
Frequency (MHz)				3745.02	3840	3935.01				
90	QPSK	1	1	22.64	22.90	22.89	0.01	0.1879	0.1954	0.1950
Channel				649334	656000	662668	MIMO Gain	EIRP	EIRP	EIRP
Frequency (MHz)				3740.01	3840	3940.02				
80	QPSK	1	1	22.63	22.89	22.91	0.01	0.1875	0.1950	0.1959
Channel				649000	656000	663000	MIMO Gain	EIRP	EIRP	EIRP
Frequency (MHz)				3735	3840	3945				
70	PI/2 BPSK	1	1	22.77	22.26	23.01	0.01	0.1936	0.1687	0.2004
Channel				648668	656000	663334	MIMO Gain	EIRP	EIRP	EIRP
Frequency (MHz)				3730.02	3840	3950.01				
60	QPSK	1	1	22.76	22.98	23.09	0.01	0.1932	0.1991	0.2042
Channel				648334	656000	663668	MIMO Gain	EIRP	EIRP	EIRP
Frequency (MHz)				3725.01	3840	3955.02				
50	QPSK	1	1	22.80	23.00	23.29	0.01	0.1950	0.2000	0.2138
Channel				648000	656000	664000	MIMO Gain	EIRP	EIRP	EIRP
Frequency (MHz)				3720	3840	3960				
40	QPSK	1	1	23.21	23.32	23.61	0.01	0.2143	0.2153	0.2301
Channel				647668	656000	664334	MIMO Gain	EIRP	EIRP	EIRP
Frequency (MHz)				3715.02	3840	3965.01				
30	QPSK	1	1	23.12	23.34	23.64	0.01	0.2099	0.2163	0.2317
Channel				647334	656000	664668	MIMO Gain	EIRP	EIRP	EIRP
Frequency (MHz)				3710.01	3840	3970.02				
20	QPSK	1	1	22.98	23.25	23.42	0.01	0.2032	0.2118	0.2203
Channel				647168	650000	652834	MIMO Gain	EIRP	EIRP	EIRP
Frequency (MHz)				3707.52	3750	3792.51				
15	PI/2 BPSK	1	1	22.56	22.37	22.45	0.01	0.1845	0.1730	0.1762
Channel				647000	650000	653000	MIMO Gain	EIRP	EIRP	EIRP
Frequency (MHz)				3705	3750	3795				
10	PI/2 BPSK	1	1	22.42	22.45	22.33	0.01	0.1786	0.1762	0.1714

MIMO Gain = Max. ant.(10, 11) + 10log2



n78 UL MIMO(Ant10+ Ant11):

BW [MHz]	Modulation	RB Size	RB Offset	Power Low Ch. / Freq.	Power Middle Ch. / Freq.	Power High Ch. / Freq.	MIMO Gain	EIRP	EIRP	EIRP
Channel				650000			MIMO Gain	L	M	H
Frequency (MHz)				3750						
100	QPSK	1	1		25.15		0.01		0.3281	
100	QPSK	1	137		24.68		0.01		0.2944	
100	QPSK	1	272		24.92		0.01		0.3112	
100	QPSK	135	0		23.20		0.01		0.2094	
100	QPSK	135	69		24.71		0.01		0.2965	
100	QPSK	135	138		23.26		0.01		0.2123	
100	QPSK	273	0		23.22		0.01		0.2104	
100	16QAM	1	1		24.05		0.01		0.2547	
100	64QAM	1	1		22.36		0.01		0.1726	
100	256QAM	1	1		20.01		0.01		0.1005	
Channel				649668	650000	650334	MIMO Gain	EIRP	EIRP	EIRP
Frequency (MHz)				3745.02	3750	3755.01				
90	QPSK	1	1	24.56	24.69	24.75	0.01	0.2864	0.2951	0.2992
Channel				649334	650000	650668	MIMO Gain	EIRP	EIRP	EIRP
Frequency (MHz)				3740.01	3750	3760.02				
80	QPSK	1	1	24.61	24.66	24.72	0.01	0.2897	0.2931	0.2972
Channel				649000	650000	651000	MIMO Gain	EIRP	EIRP	EIRP
Frequency (MHz)				3735	3750	3765				
70	PI/2 BPSK	1	1	24.40	24.58	24.59	0.01	0.2761	0.2877	0.2884
Channel				648668	650000	651334	MIMO Gain	EIRP	EIRP	EIRP
Frequency (MHz)				3730.02	3750	3770.01				
60	QPSK	1	1	24.76	24.71	24.84	0.01	0.2999	0.2965	0.3055
Channel				648334	650000	651668	MIMO Gain	EIRP	EIRP	EIRP
Frequency (MHz)				3725.01	3750	3775.02				
50	QPSK	1	1	24.77	24.80	24.79	0.01	0.3006	0.3027	0.3020
Channel				648000	650000	652000	MIMO Gain	EIRP	EIRP	EIRP
Frequency (MHz)				3720	3750	3780				
40	QPSK	1	1	25.08	25.02	25.02	0.01	0.3228	0.3184	0.3184
Channel				647668	650000	652334	MIMO Gain	EIRP	EIRP	EIRP
Frequency (MHz)				3715.02	3750	3785.01				
30	QPSK	1	1	25.04	25.00	25.11	0.01	0.3199	0.3170	0.3251
Channel				647334	650000	652668	MIMO Gain	EIRP	EIRP	EIRP
Frequency (MHz)				3710.01	3750	3790.02				
20	QPSK	1	1	25.08	25.02	25.10	0.01	0.3228	0.3184	0.3243
Channel				647168	650000	652834	MIMO Gain	EIRP	EIRP	EIRP
Frequency (MHz)				3707.52	3750	3792.51				
15	PI/2 BPSK	1	1	25.07	25.02	25.01	0.01	0.3221	0.3184	0.3177
Channel				647000	650000	653000	MIMO Gain	EIRP	EIRP	EIRP
Frequency (MHz)				3705	3750	3795				
10	PI/2 BPSK	1	1	25.11	24.88	25.01	0.01	0.3251	0.3083	0.3177

MIMO Gain = Max. ant.(10, 11) + 10log2



FR1 n77

Peak-to-Average Ratio

Mode	FR1 n71 / 100MHz / DFT-S OFDM				
Mod.	100M				Limit: 13dB
RB Size	BPSK	QPSK	16QAM	64QAM	Result
Middle CH	5.24	5.47	5.27	5.44	PASS
RB Size	256QAM				
Middle CH	5.37				

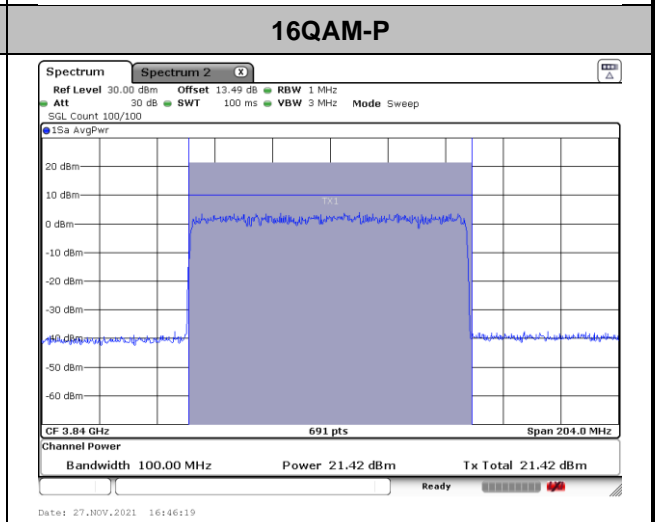
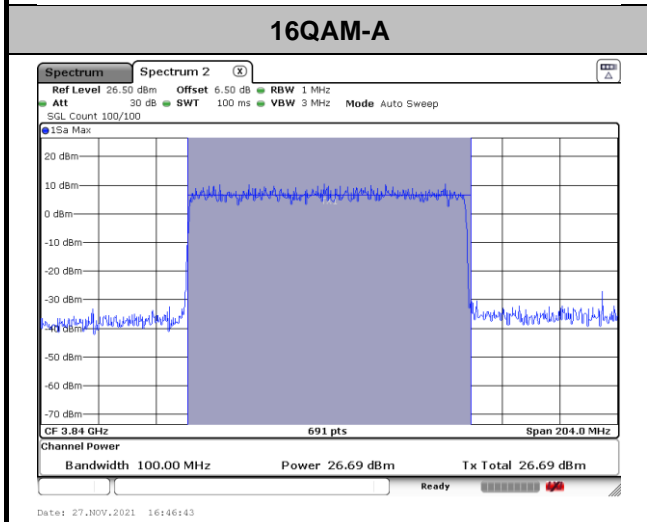
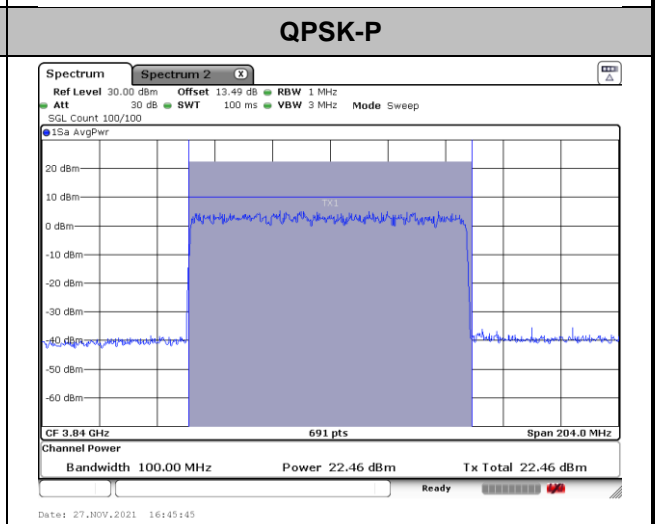
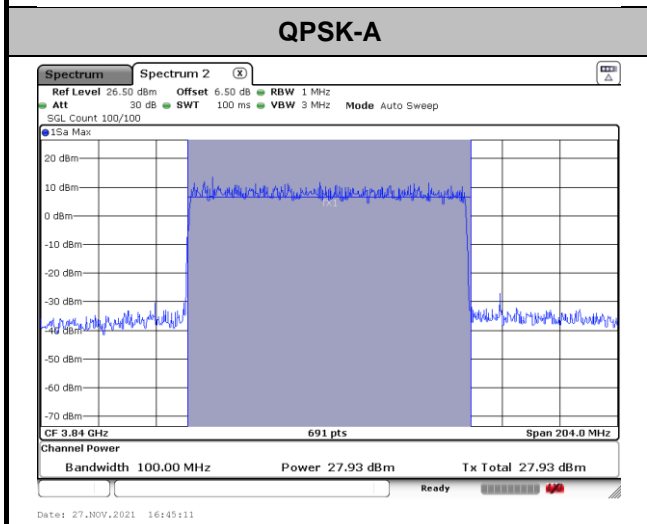
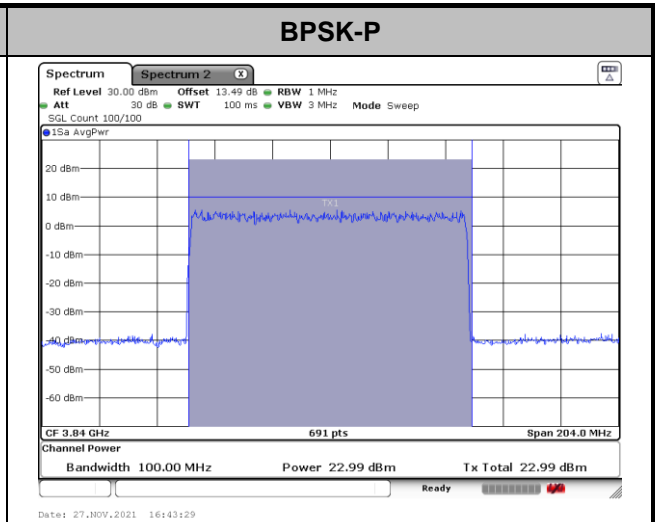
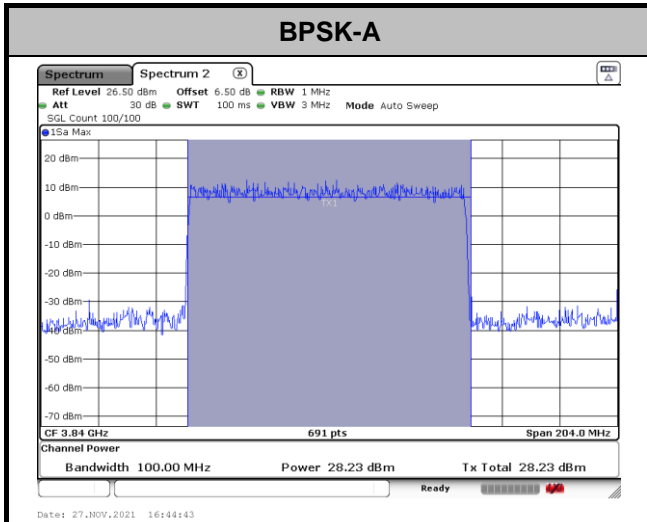



64QAM-A

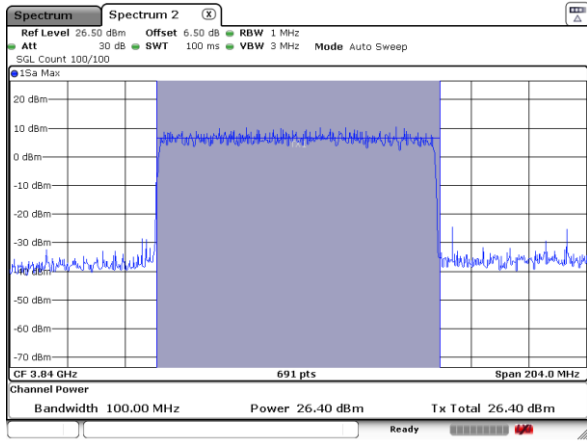

Date: 27.NOV.2021 16:47:18

64QAM-P

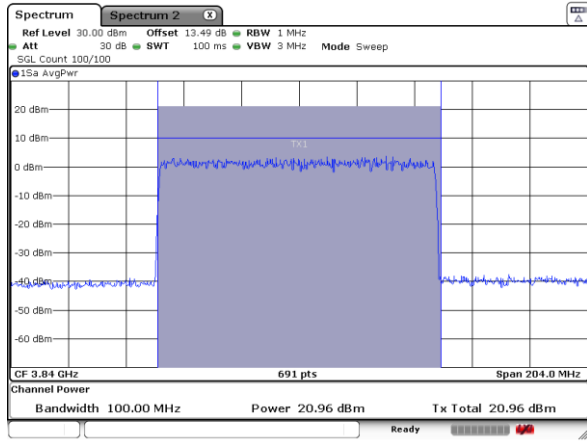

Date: 27.NOV.2021 16:47:41

256QAM-A

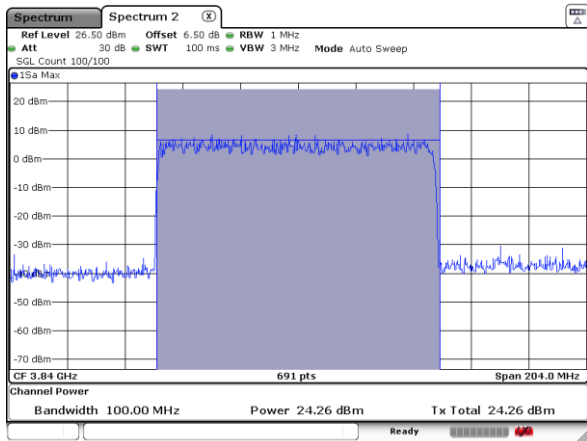

Date: 27.NOV.2021 16:49:23

256QAM-P

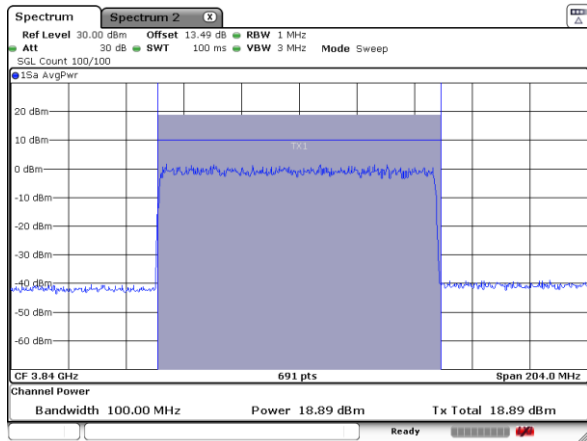

Date: 27.NOV.2021 16:48:44



26dB Bandwidth

Mode	FR1 n77 : 26dB BW(MHz) / DFT-S OFDM	
BW	DFT	
Mod.	QPSK	16QAM
Middle CH	102.3	102.7

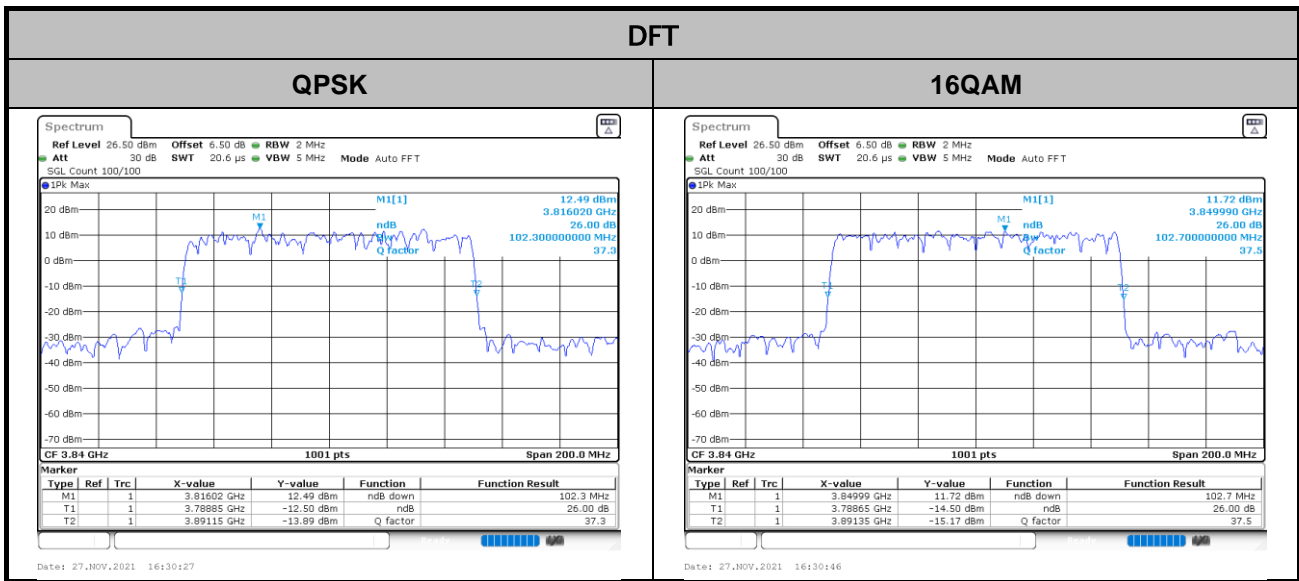



Occupied Bandwidth

Mode	FR1 n77: OB BW(MHz) / DFT-S OFDM	
BW	DFT	
Mod.	QPSK	16QAM
Middle CH	97.70	98.30

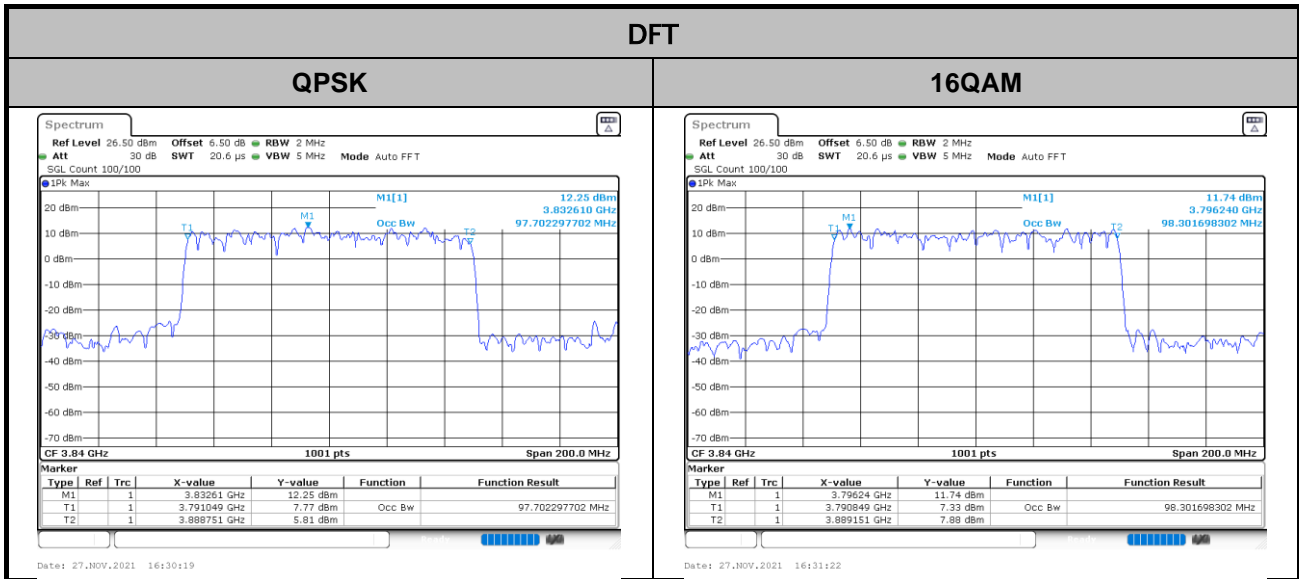



Conducted Band Edge

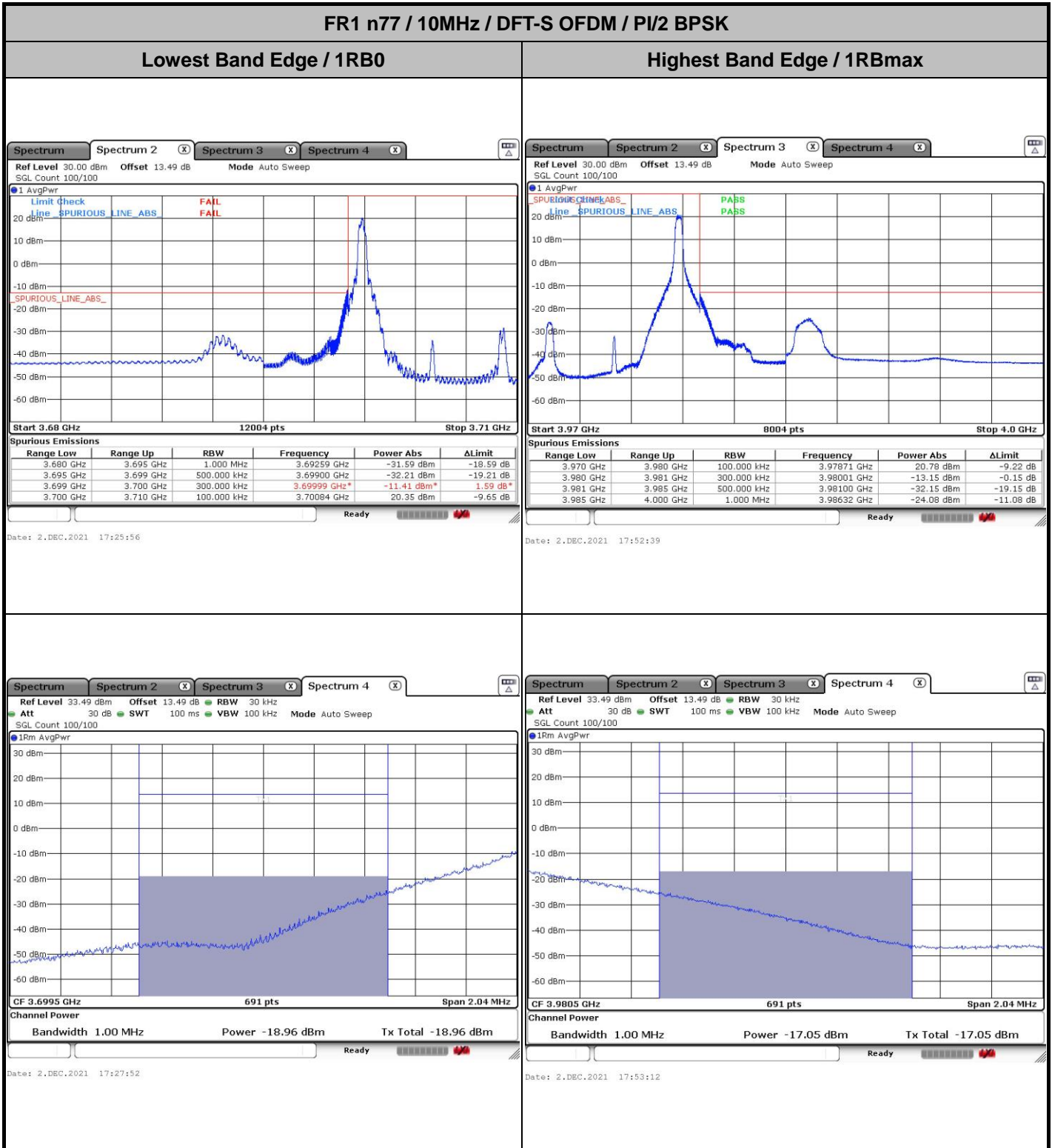

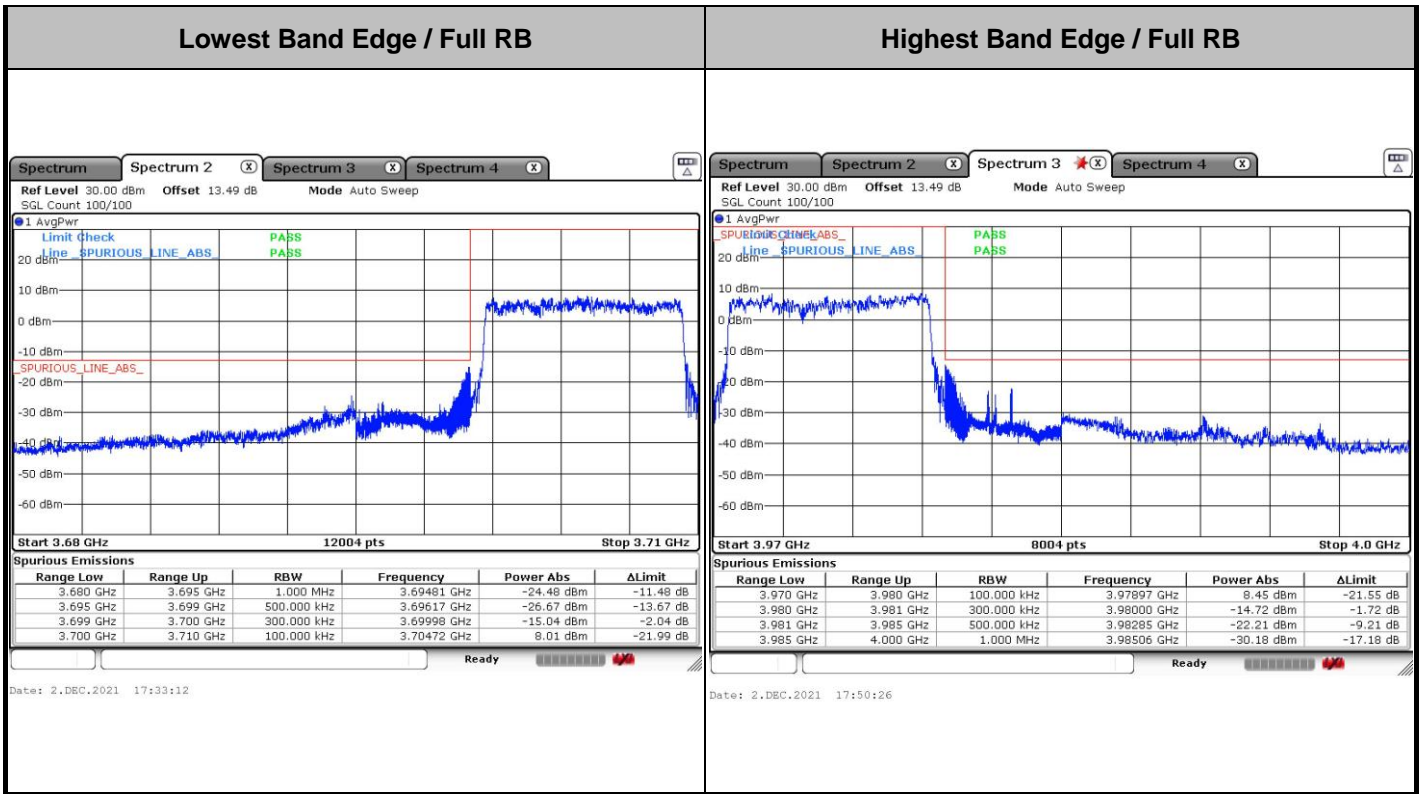



FR1 n77 / 10MHz / DFT-S OFDM / QPSK

Lowest Band Edge / 1RB0

Highest Band Edge / 1RBmax

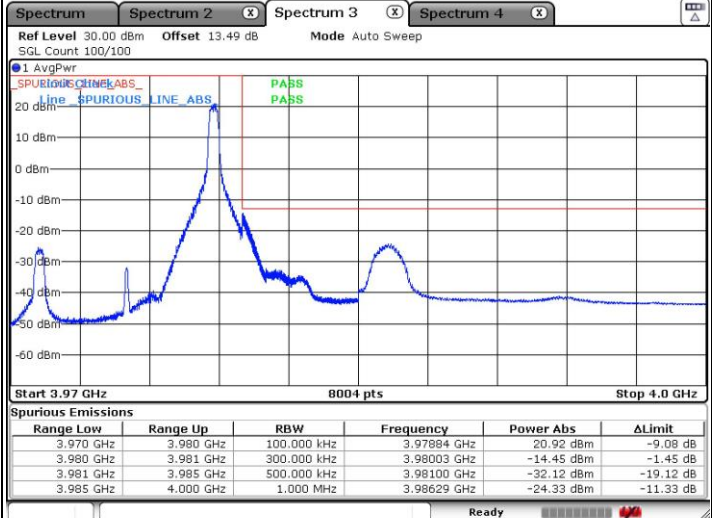
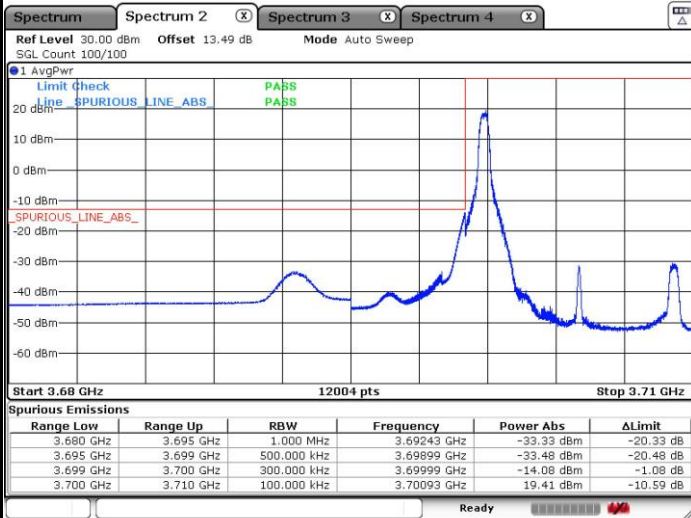

Date: 2.DEC.2021 17:22:16

Date: 2.DEC.2021 17:40:29

Lowest Band Edge / Full RB

Highest Band Edge / Full RB

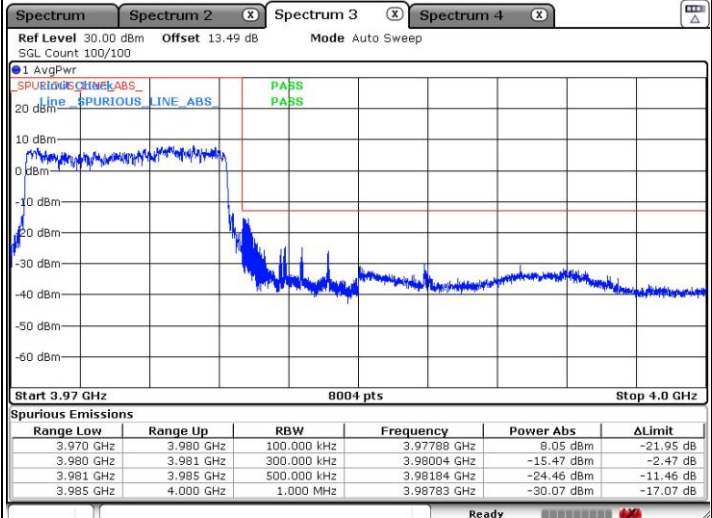
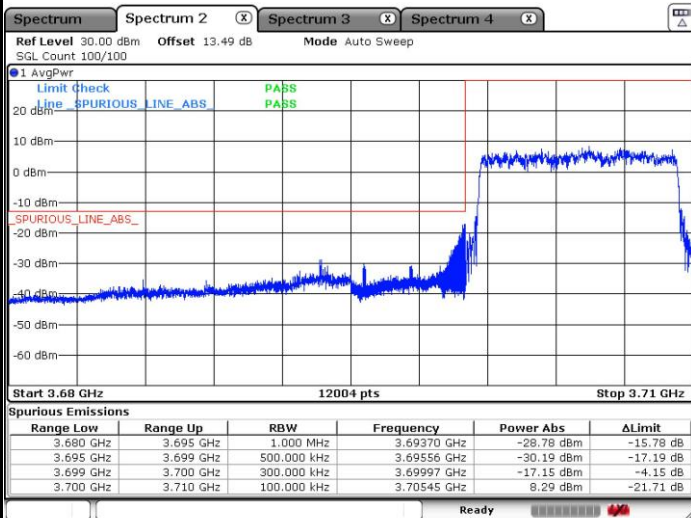

Date: 2.DEC.2021 17:32:51

Date: 2.DEC.2021 17:50:02



FR1 n77 / 10MHz / DFT-S OFDM / 16Q

Lowest Band Edge / 1RB0

Highest Band Edge / 1RBmax

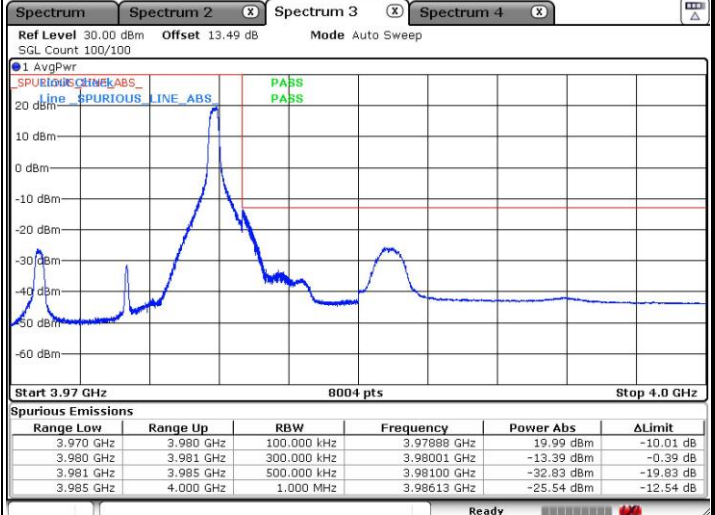
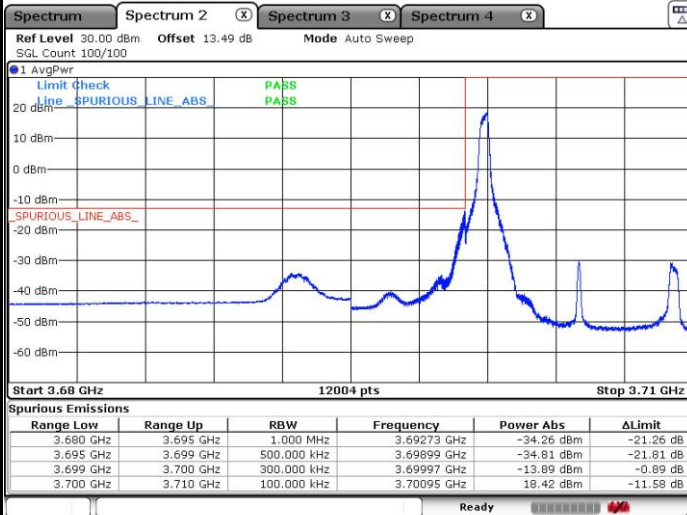

Date: 2.DEC.2021 17:29:01

Date: 2.DEC.2021 17:41:43

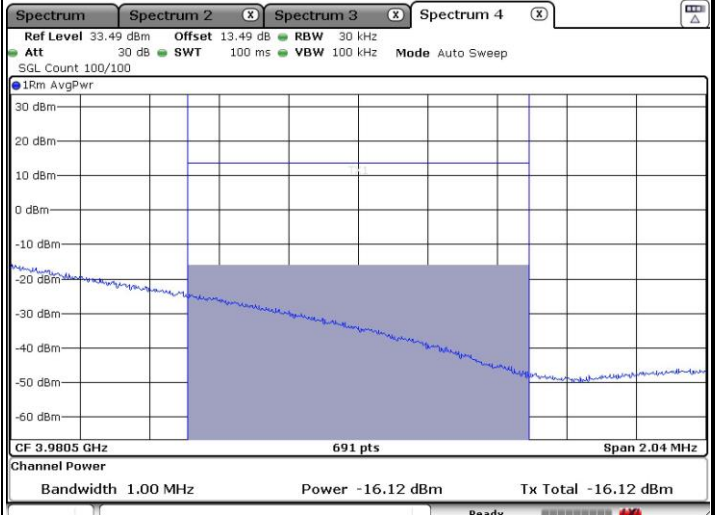
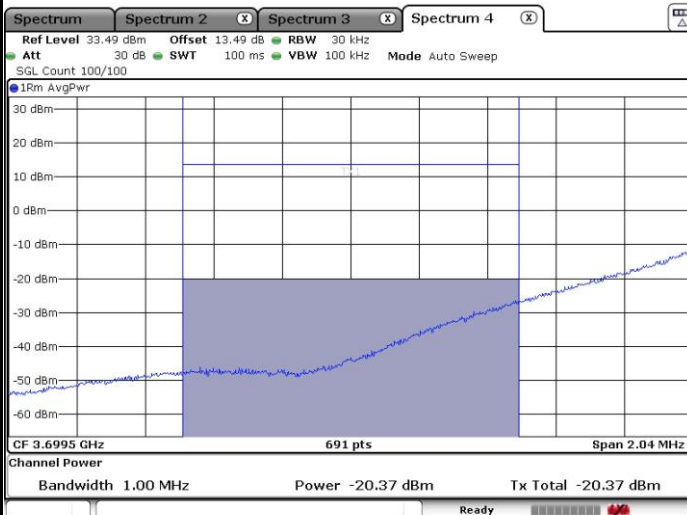

Date: 2.DEC.2021 17:29:26

Date: 2.DEC.2021 17:42:56

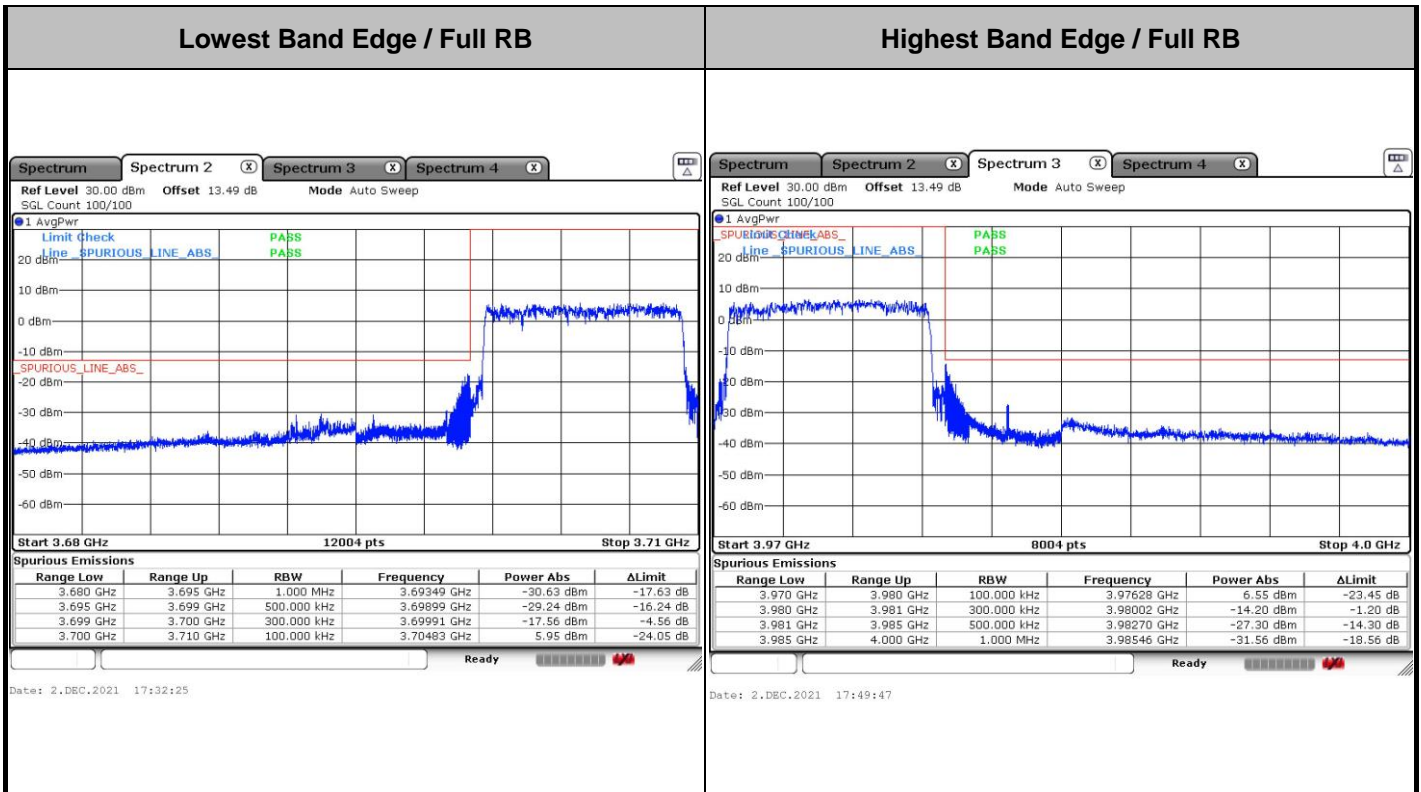



FR1 n77 / 10MHz / DFT-S OFDM / 64Q

Lowest Band Edge / 1RB0

Highest Band Edge / 1RB24

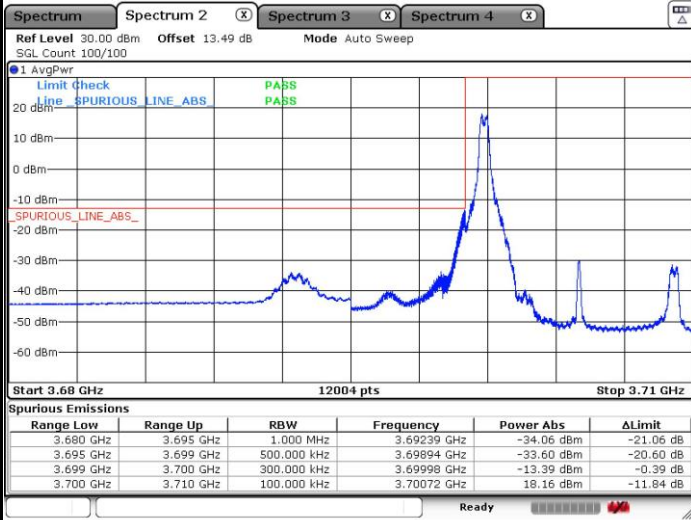

Date: 2.DEC.2021 17:31:00

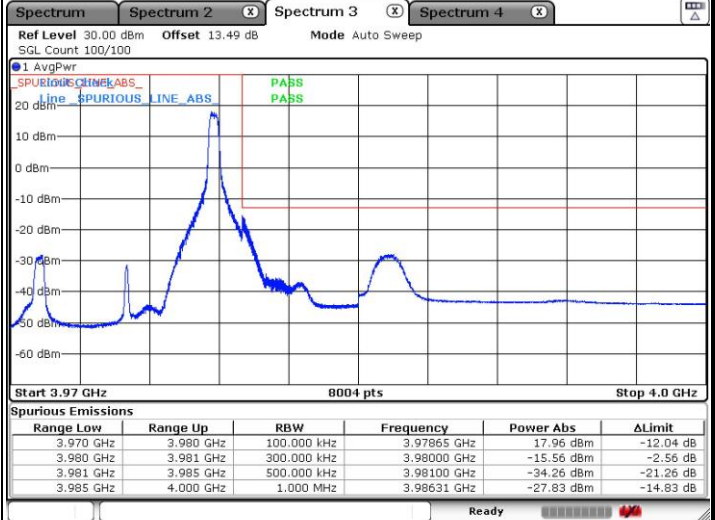

Date: 2.DEC.2021 17:44:08

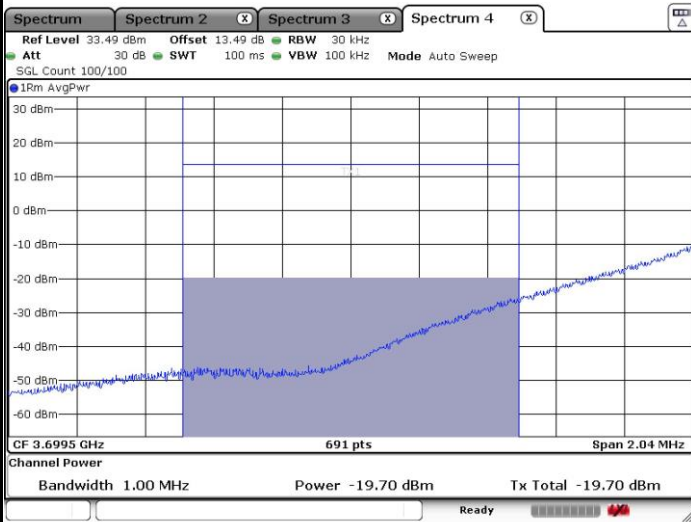

Date: 2.DEC.2021 17:31:22

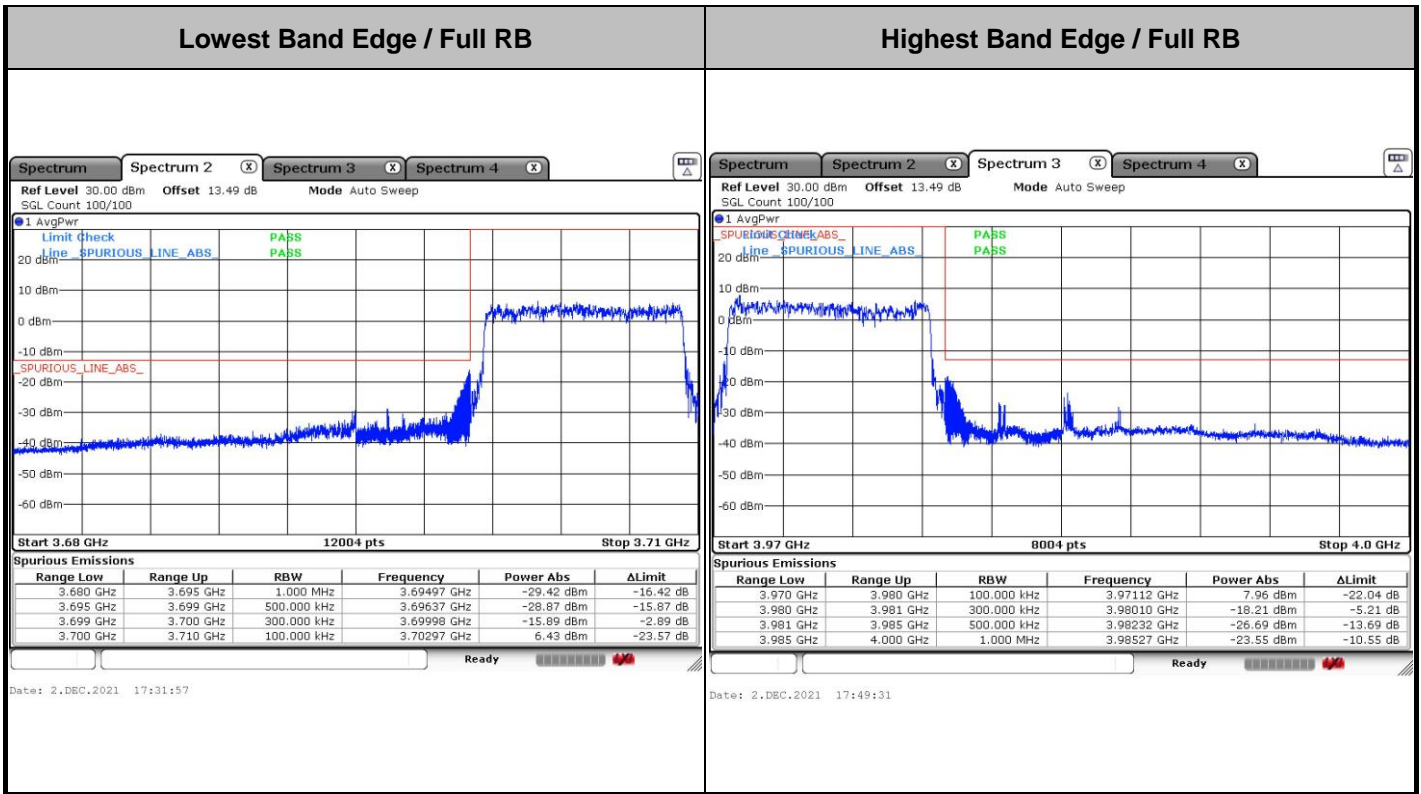



FR1 n77 / 10MHz / DFT-S OFDM / 256Q

Lowest Band Edge / 1RB0

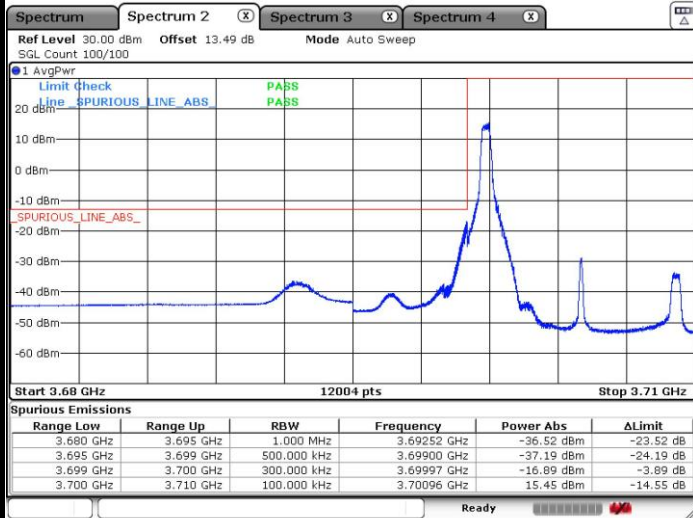

Date: 2.DEC.2021 17:34:46

Highest Band Edge / 1RB24

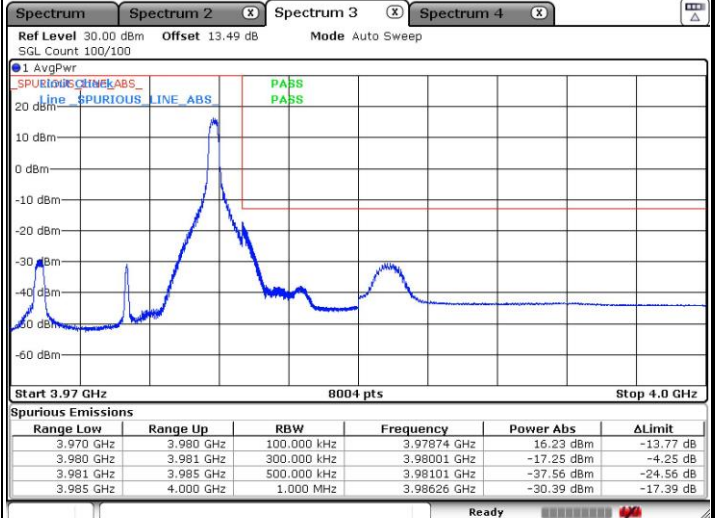

Date: 2.DEC.2021 17:45:14

Lowest Band Edge / Full RB

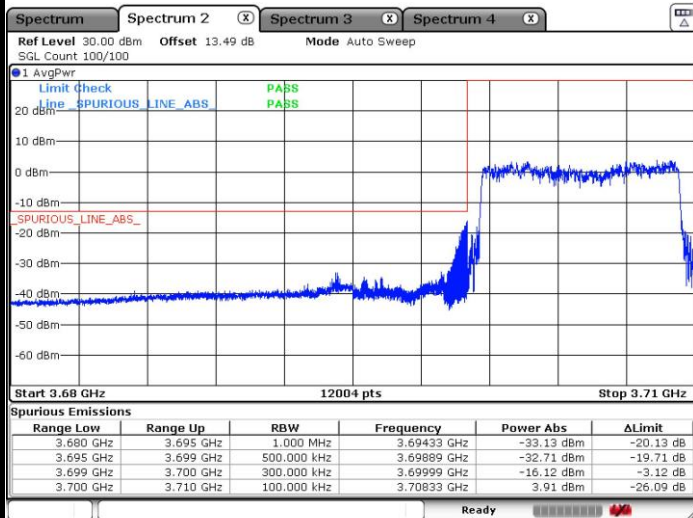

Date: 2.DEC.2021 17:33:35

Highest Band Edge / Full RB

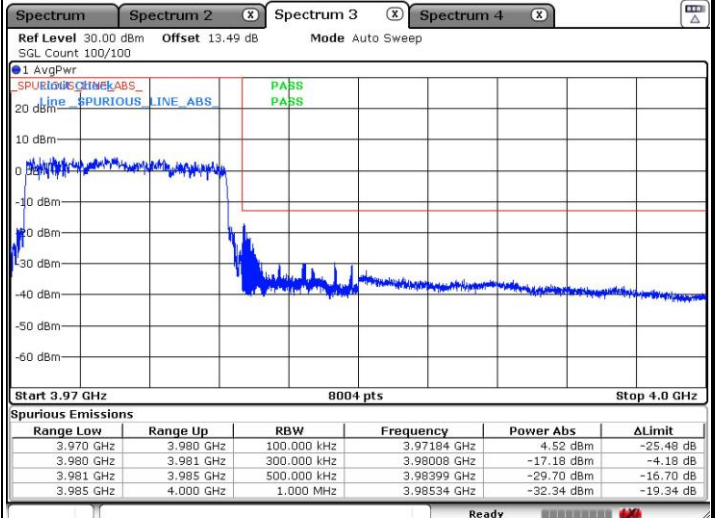

Date: 2.DEC.2021 17:49:09



FR1 n77 / 15MHz / DFT-S OFDM / PI/2 BPSK

Lowest Band Edge / 1RB0

Highest Band Edge / 1RBmax

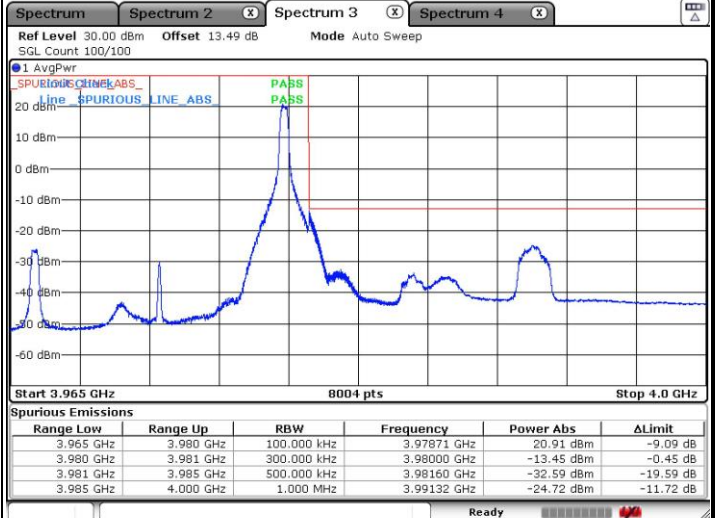
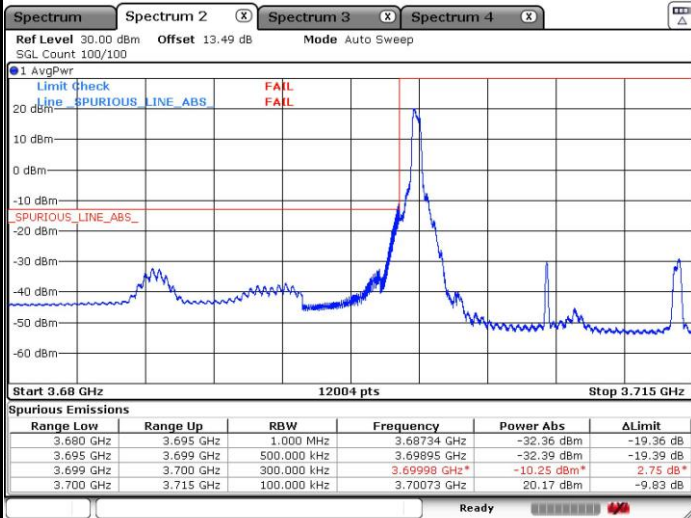

Date: 2.DEC.2021 18:05:20

Date: 2.DEC.2021 18:26:33

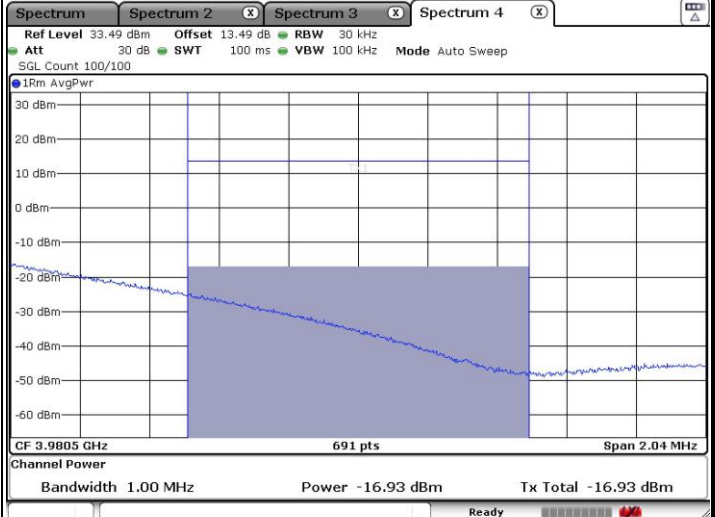
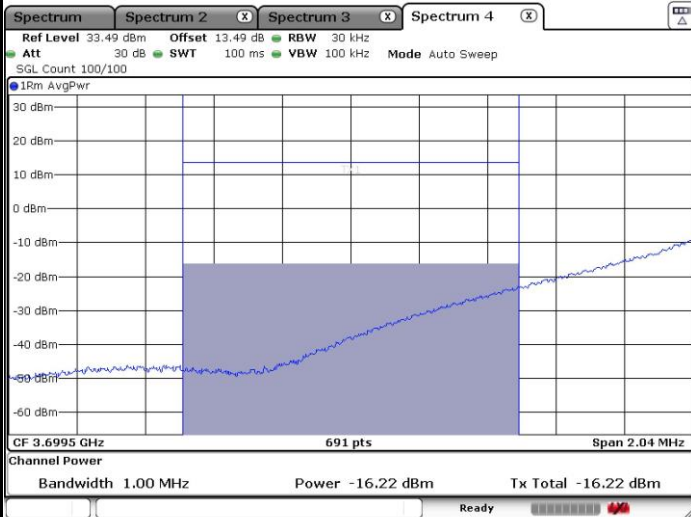

Date: 2.DEC.2021 18:05:47

Date: 2.DEC.2021 18:27:04

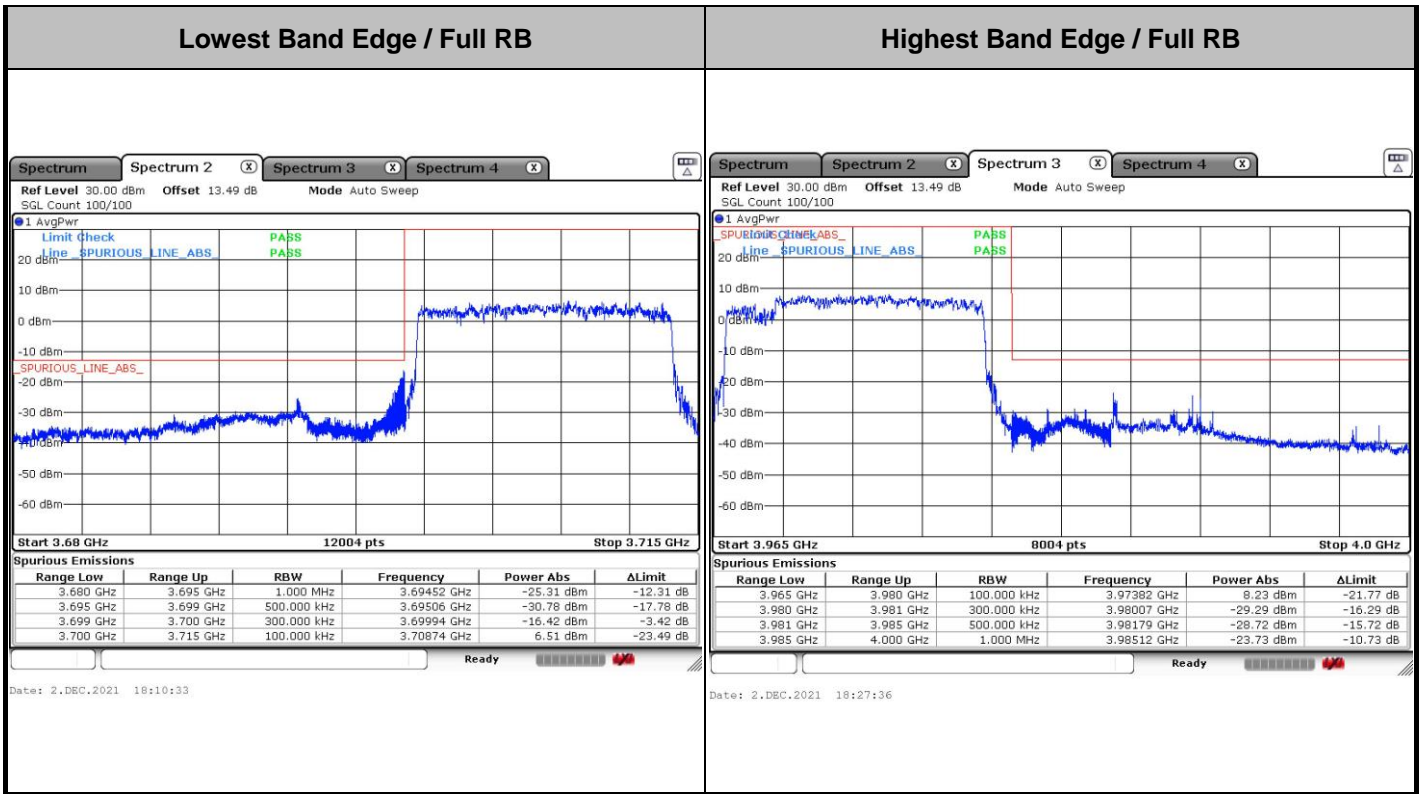



FR1 n77 / 15MHz / DFT-S OFDM / QPSK

Lowest Band Edge / 1RB0

Highest Band Edge / 1RBmax

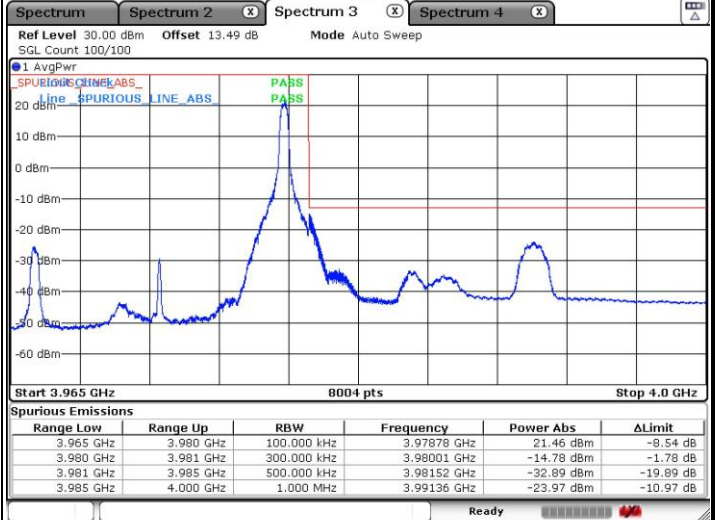
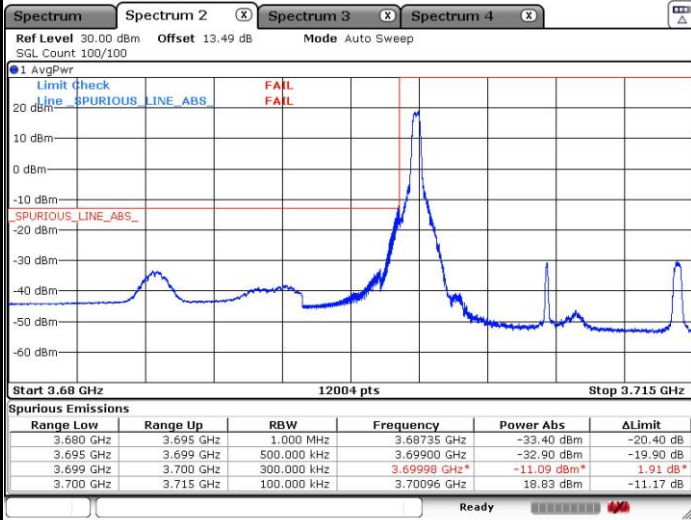

Date: 2.DEC.2021 18:02:10

Date: 2.DEC.2021 18:25:29

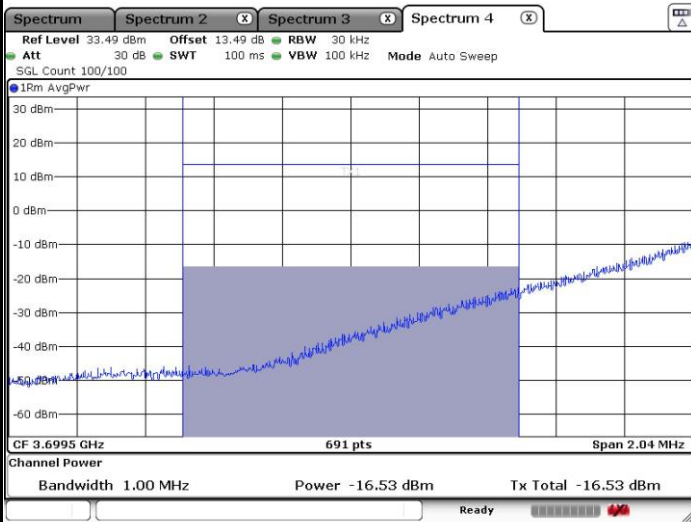

Date: 2.DEC.2021 18:04:18

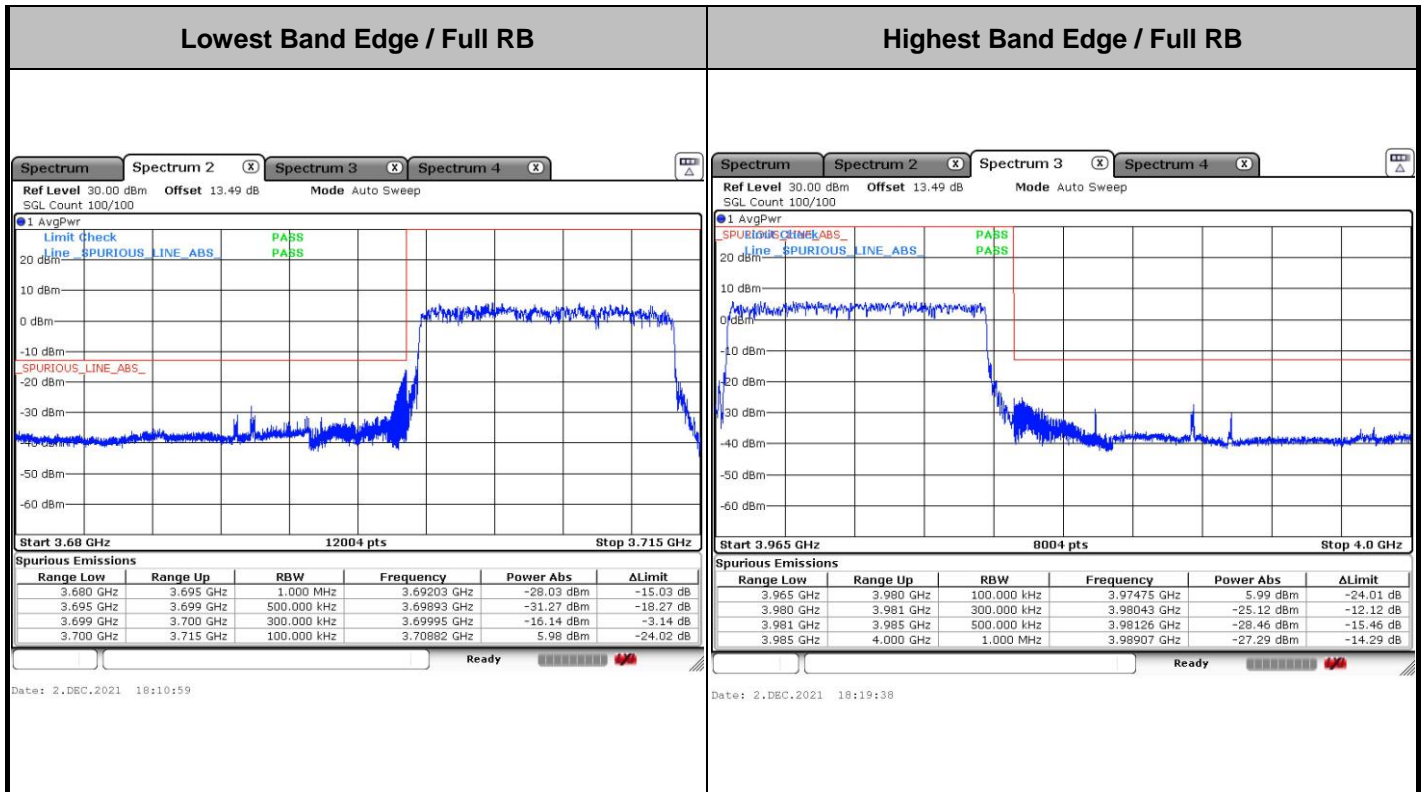



FR1 n77 / 15MHz / DFT-S OFDM / 16Q

Lowest Band Edge / 1RB0

Highest Band Edge / 1RBmax

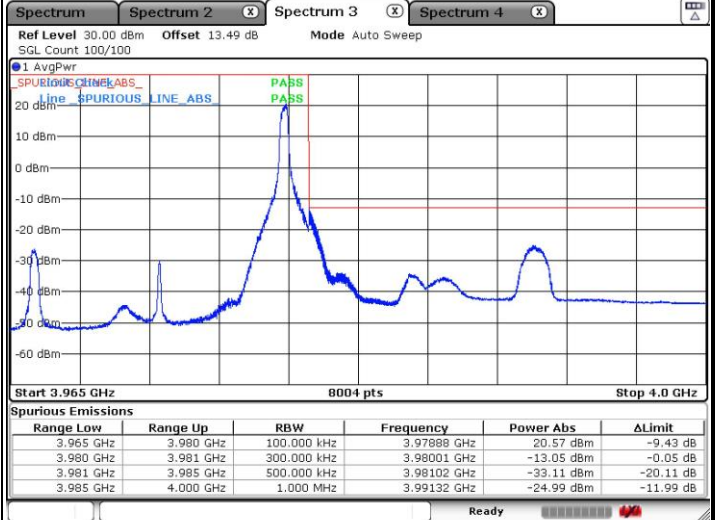
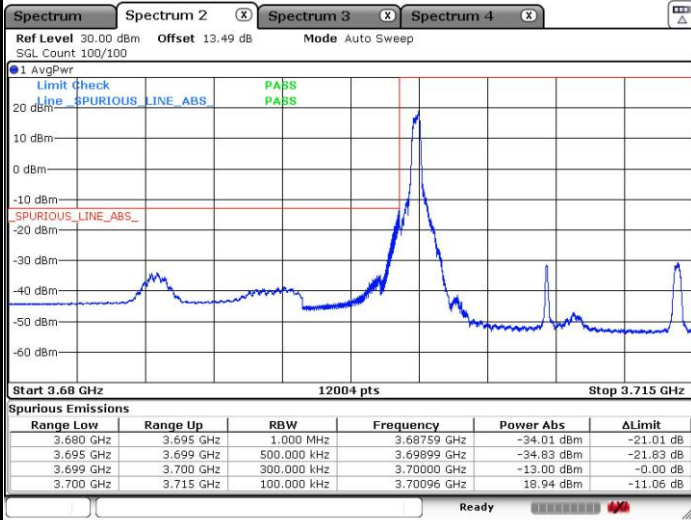

Date: 2.DEC.2021 18:06:47

Date: 2.DEC.2021 18:24:27

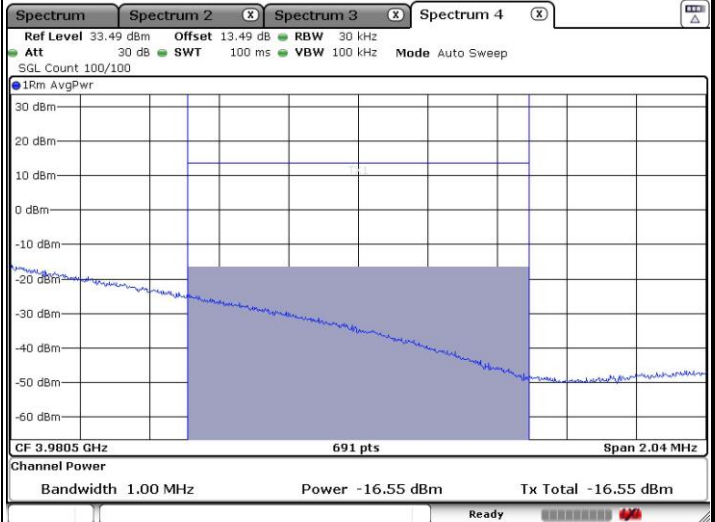
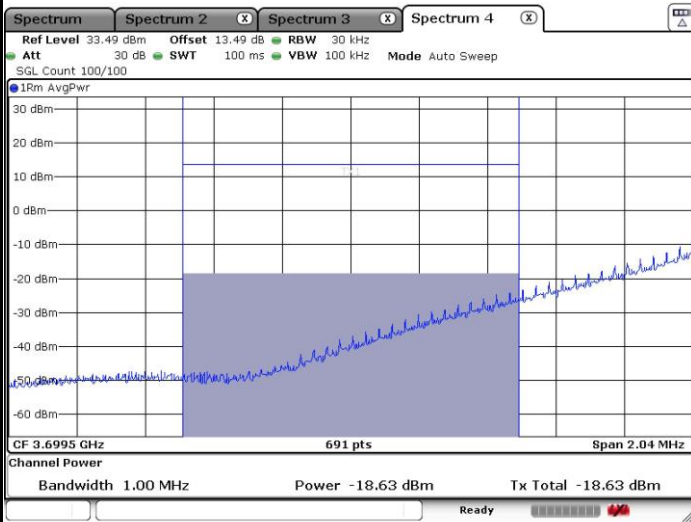

Date: 2.DEC.2021 18:07:11

Date: 2.DEC.2021 18:31:36

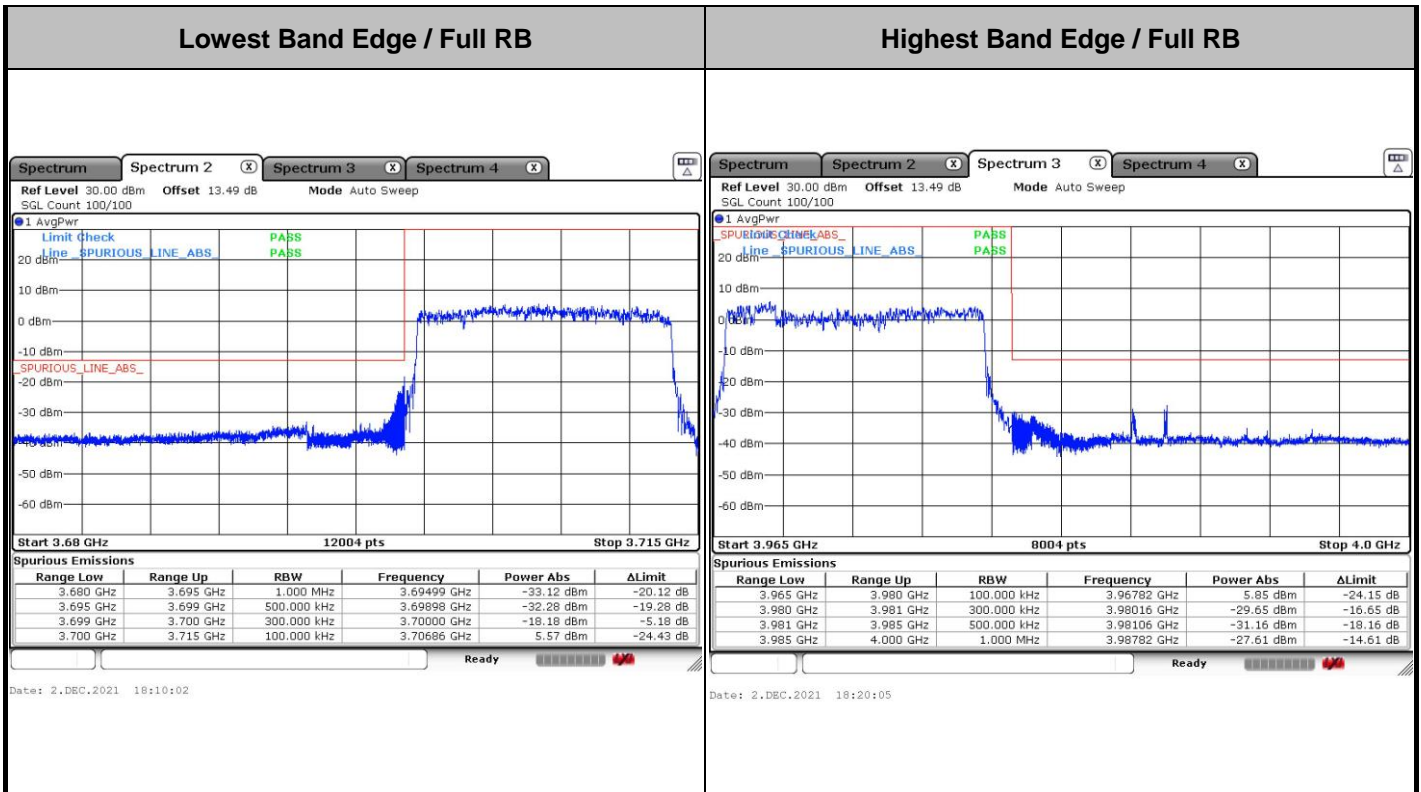



FR1 n77 / 15MHz / DFT-S OFDM / 64Q

Lowest Band Edge / 1RB0

Highest Band Edge / 1RB24

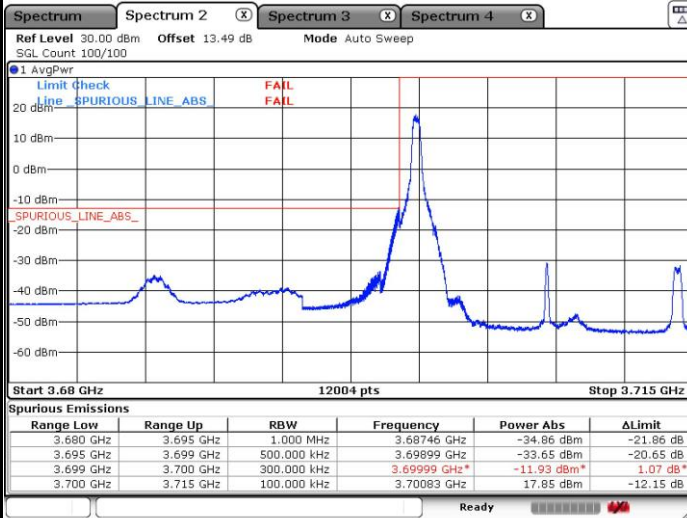

Date: 2.DEC.2021 18:08:18

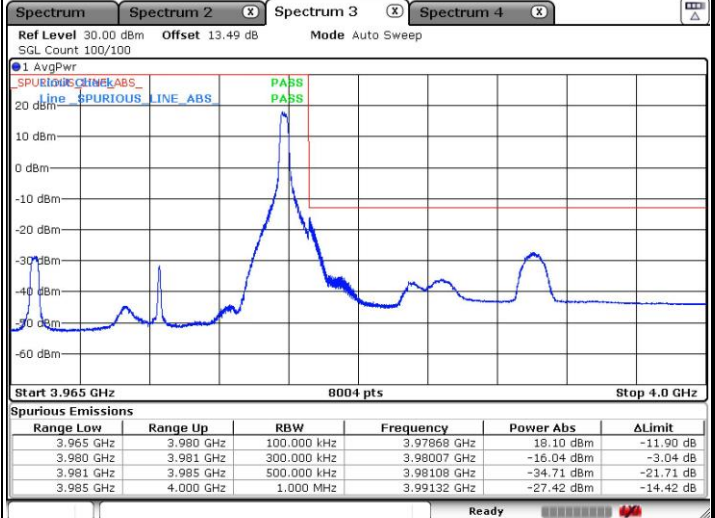

Date: 2.DEC.2021 18:23:27

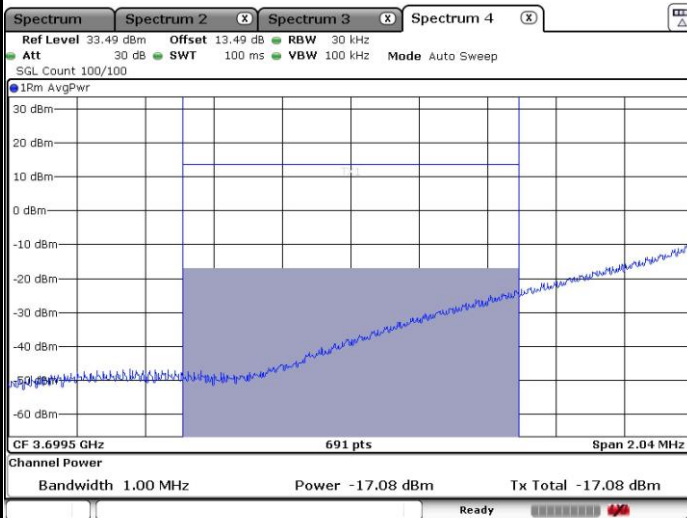

Date: 2.DEC.2021 18:08:43

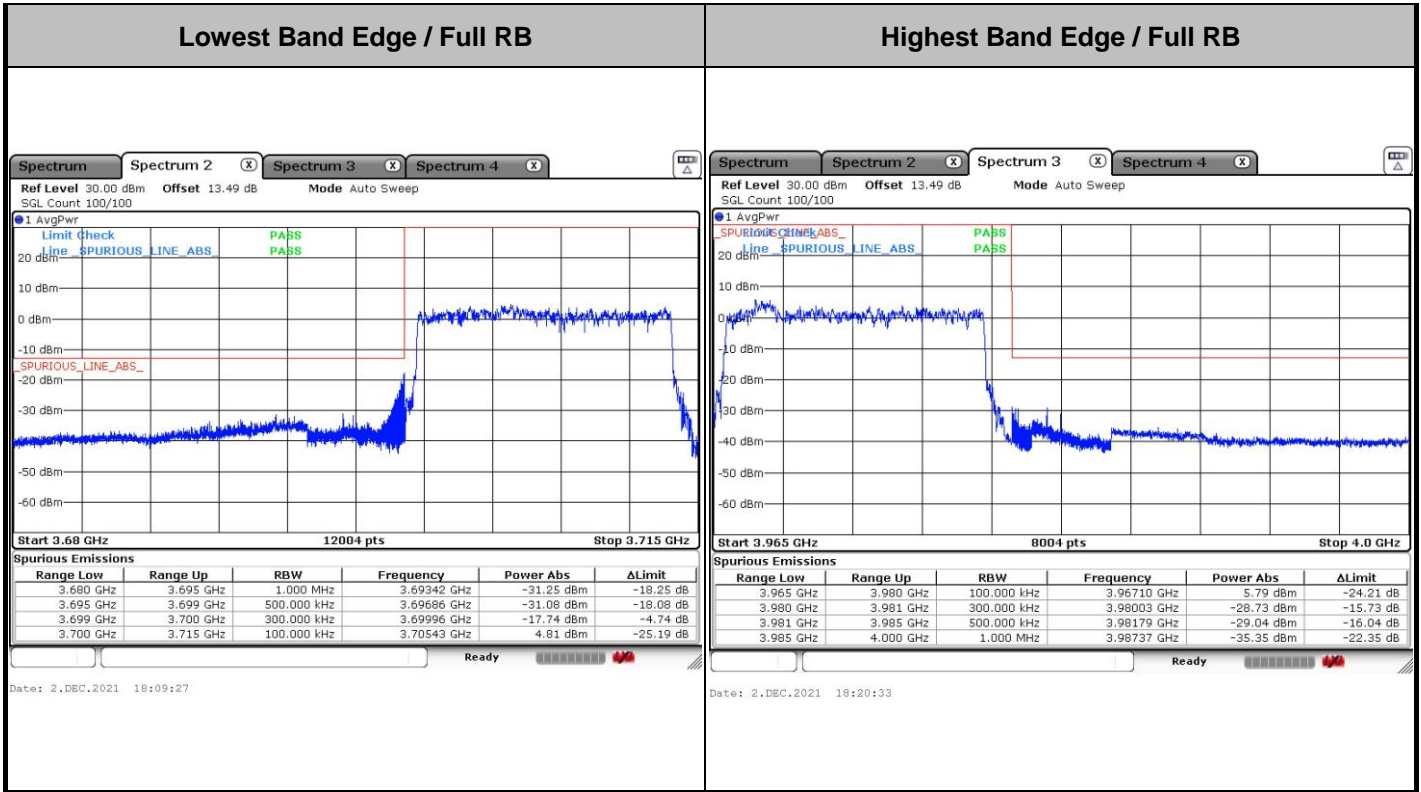



FR1 n77 / 15MHz / DFT-S OFDM / 256Q

Lowest Band Edge / 1RB0

Highest Band Edge / 1RB24

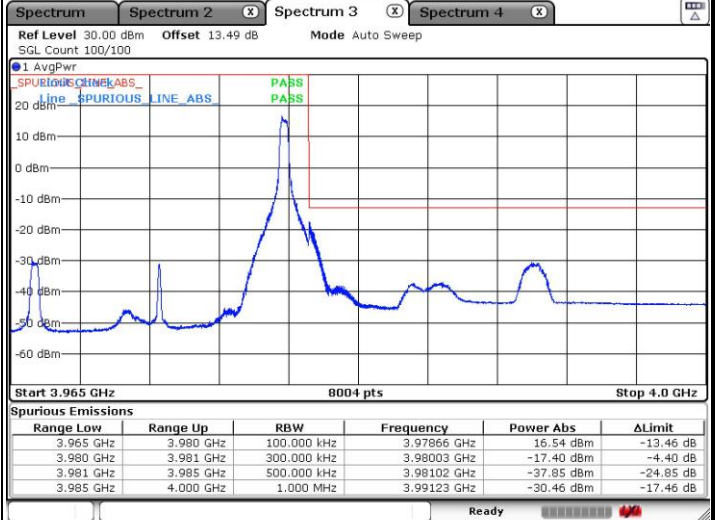
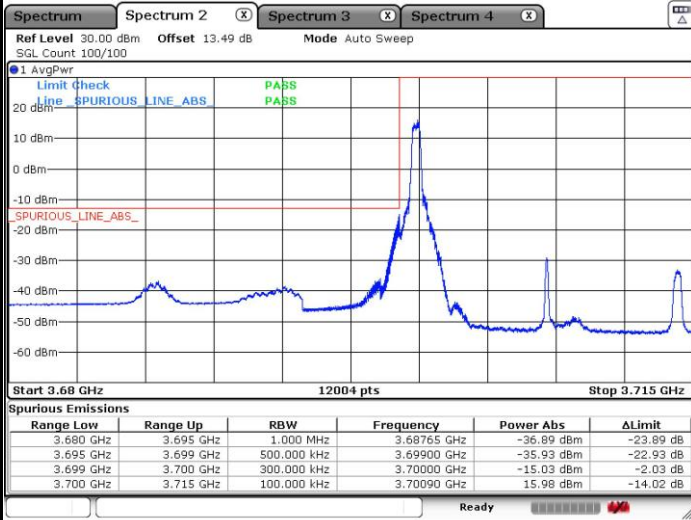

Date: 2.DEC.2021 18:12:39

Date: 2.DEC.2021 18:22:14

Lowest Band Edge / Full RB

Highest Band Edge / Full RB

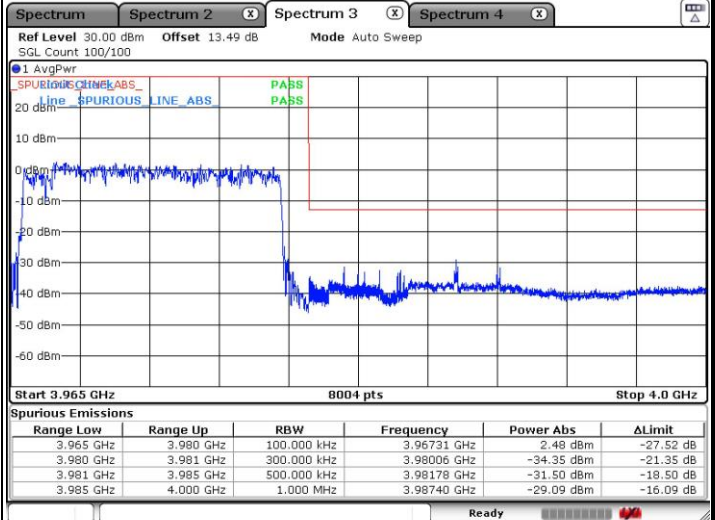
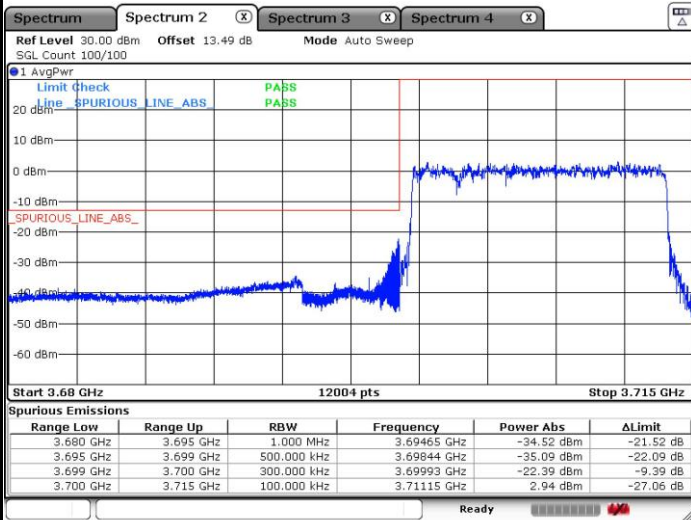

Date: 2.DEC.2021 18:11:23

Date: 2.DEC.2021 18:20:53



FR1 n77 / 20MHz / DFT-S OFDM / PI/2 BPSK

Lowest Band Edge / 1RB0

Highest Band Edge / 1RBmax

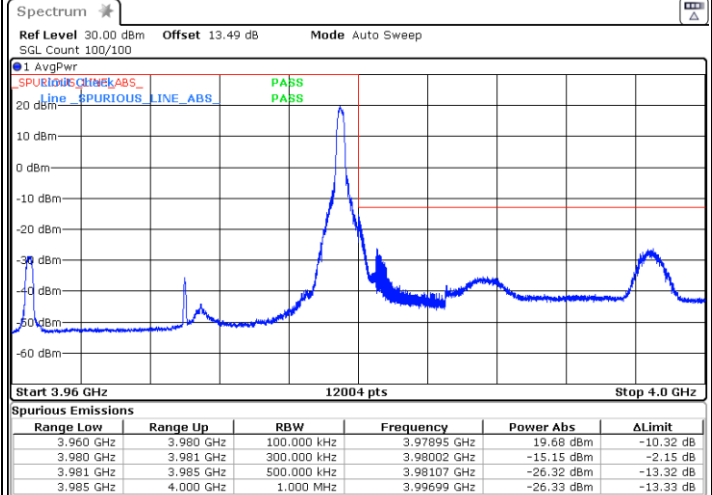
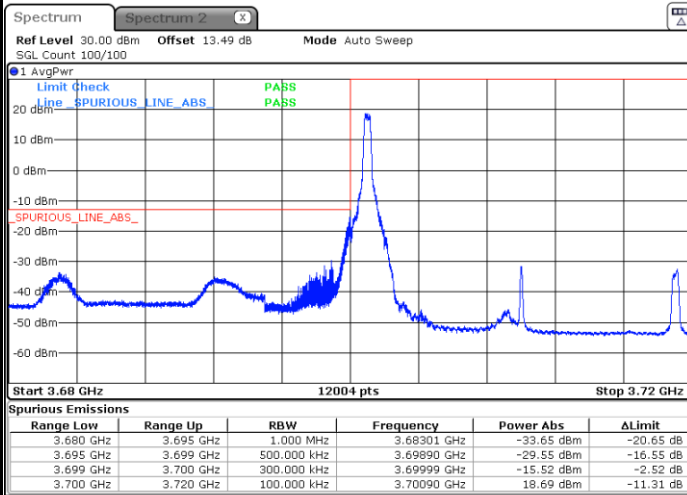

Date: 27.NOV.2021 01:03:54

Date: 26.NOV.2021 20:41:33

Lowest Band Edge / Full RB

Highest Band Edge / Full RB

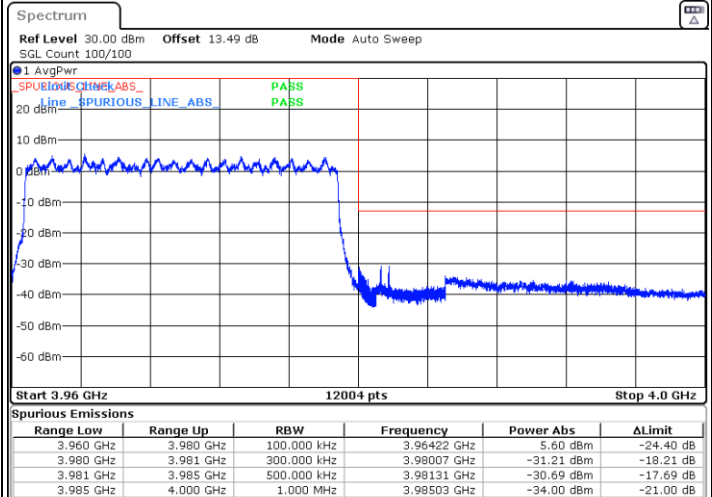
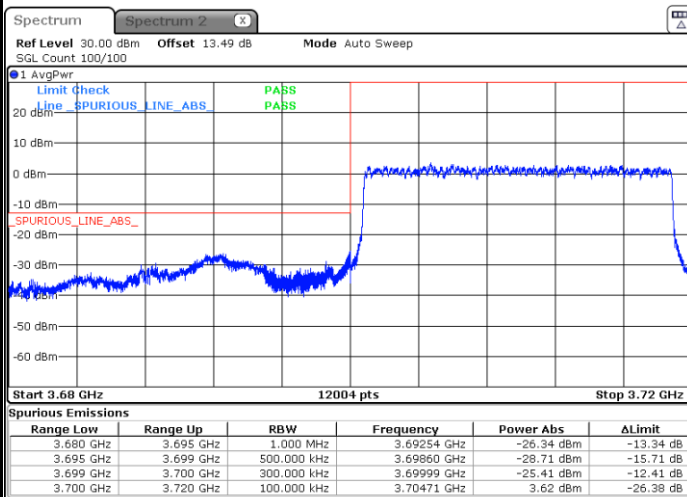

Date: 27.NOV.2021 01:45:33

Date: 26.NOV.2021 20:49:12