

TEST REPORT

Product Name : Xiaomi Smart Projector L1
Model Number : XMTYY03FMG, XMTYY**FMG (*=0-9, indicates for different market purposes)
FCC ID : 2AFZZ-XMTYY03FMG

Prepared for : Xiaomi Communications Co., Ltd.
Address : #019, 9th Floor, Building 6, 33 Xi'erqi Middle Road, Haidian District, Beijing, 100085, China

Prepared by : EMTEK (SHENZHEN) CO., LTD.
Address : Building 69, Majialong Industry Zone, Nanshan District, Shenzhen, Guangdong, China

Tel: (0755) 26954280

Fax: (0755) 26954282

Report Number : ENS2406060159W00204R
Date(s) of Tests : June 8, 2024 to July 24, 2024
Date of issue : July 27, 2024

1 TEST RESULT CERTIFICATION

Applicant : Xiaomi Communications Co., Ltd.
 Address : #019, 9th Floor, Building 6, 33 Xi'erqi Middle Road, Haidian District, Beijing, 100085, China
 Manufacturer : Xiaomi Communications Co., Ltd.
 Address : #019, 9th Floor, Building 6, 33 Xi'erqi Middle Road, Haidian District, Beijing, 100085, China
 EUT : Xiaomi Smart Projector L1
 Model Name : XMTYY03FMG, XMTYY**FMG (*=0-9, indicates for different market purposes)
 Trademark : Xiaomi

Measurement Procedure Used:

APPLICABLE STANDARDS	
STANDARD	TEST RESULT
FCC 47 CFR Part 2, Subpart J FCC 47 CFR Part 15, Subpart E	PASS
IC RSS-GEN, Issue 5(04-2018)+A1(03-2019)+A2(02-2021) IC RSS-247 Issue 3(08-2023)	PASS

The above equipment was tested by EMTEK (SHENZHEN) CO., LTD. The test data, data evaluation, test procedures, and equipment configurations shown in this report were made in accordance with the procedures given in ANSI C63.10 (2013) and the energy emitted by the sample EUT tested as described in this report is in compliance with the requirements of FCC Rules Part 2, Part 15.407, IC RSS-247 Issue 3 and IC RSS-GEN, Issue 5.

The test results of this report relate only to the tested sample identified in this report.

Date of Test : June 8, 2024 to July 24, 2024

Prepared by : 
Luo peiye /Editor

Reviewer : 
Joe Xia/Supervisor

Approve & Authorized Signer : 
Lisa Wang/Manager



Modified History

Version	Report No.	Revision Date	Summary
Ver.1.0	ENS2406060159W00204R	/	Original Report



TABLE OF CONTENTS

1 TEST RESULT CERTIFICATION	2
2 EUT TECHNICAL DESCRIPTION	5
3 SUMMARY OF TEST RESULT	7
4 TEST METHODOLOGY	8
4.1 GENERAL DESCRIPTION OF APPLIED STANDARDS	8
4.2 MEASUREMENT EQUIPMENT USED	8
4.3 DESCRIPTION OF TEST MODES	9
5 FACILITIES AND ACCREDITATIONS	13
5.1 FACILITIES	13
5.2 EQUIPMENT	13
5.3 LABORATORY ACCREDITATIONS AND LISTINGS	13
6 TEST SYSTEM UNCERTAINTY	14
7 SETUP OF EQUIPMENT UNDER TEST	15
7.1 RADIO FREQUENCY TEST SETUP	15
7.2 RADIO FREQUENCY TEST SETUP	15
7.3 CONDUCTED EMISSION TEST SETUP	17
7.4 BLOCK DIAGRAM CONFIGURATION OF TEST SYSTEM	18
7.5 SUPPORT EQUIPMENT	18
8 TEST REQUIREMENTS	19
8.1 BANDWIDTH MEASUREMENT	19
8.2 MAXIMUM CONDUCTED OUTPUT POWER	118
8.3 MAXIMUM PEAK POWER DENSITY	163
8.4 UNDESIRABLE RADIATED SPURIOUS EMISSION	209
8.5 POWER LINE CONDUCTED EMISSIONS	238
8.6 ANTENNA APPLICATION	241
9 APPENDIX PHOTOGRAPHS OF EUT	242
10 APPENDIX PHOTOGRAPHS OF TEST SETUP	243

2 EUT TECHNICAL DESCRIPTION

Characteristics	Description
Product:	Xiaomi Smart Projector L1
Model Number:	XMTYY03FMG, XMTYY**FMG (*=0-9, indicates for different market purposes) (Note: All models are identical in circuitry and electrical, mechanical and physical construction; the difference are model number for trading purpose. Mode XMM2102 was Chosen final test.)
Sample Number:	2#
Wifi Type:	Wifi 5G with 5150MHz-5250MHz Band Wifi 5G with 5250MHz-5350MHz Band Wifi 5G with 5470MHz-5725MHz Band Wifi 5G with 5725MHz-5850MHz Band
WLAN Supported:	802.11a/n/ac
Data Rate :	802.11a: 54/48/36/24/12/9/6Mbps 802.11n: MCS0-MCS7 802.11ac: MCS0-MCS9
Modulation:	OFDM with BPSK/QPSK/16QAM/64QAM for 802.11a/n OFDM with BPSK/QPSK/16QAM/64QAM/256QAM for 802.11ac
Frequency Range:	UNII-1: 5150MHz-5250MHz Band 5180-5240MHz for 802.11a/n(HT20)/ac(VHT20) 5190-5230MHz for 802.11n(HT40)/ac(VHT40) 5210MHz for 802.11ac(VHT80)
	UNII-2A: 5250MHz-5350MHz Band 5260-5320MHz for 802.11a/n(HT20)/ac(VHT20) 5270-5310MHz for 802.11n(HT40)/ac(VHT40) 5290MHz for 802.11ac(VHT80)
	UNII-2C: 5470MHz-5725MHz Band 5500-5700MHz for 802.11a/n(HT20)/ac(VHT20) 5510-5670MHz for 802.11n(HT40)/ac(VHT40) 5530MHz for 802.11ac(VHT80)
	UNII-3 with 5725MHz-5850MHz Band 5745-5825MHz for 802.11a/n(HT20)/ac(VHT20) 5755-5795MHz for 802.11n(HT40)/ac(VHT40) 5775MHz for 802.11ac(VHT80);
TPC Function:	Not Applicable
Antenna Port:	<input checked="" type="checkbox"/> Antenna port 1 <input checked="" type="checkbox"/> Antenna port 2
Antenna Type:	FPC Antenna
Antenna Gain:	<input checked="" type="checkbox"/> ANT 1: 2.97 dBi <input checked="" type="checkbox"/> ANT 2: 2.52 dBi

Power Supply:	DC 19V from adapter
Adapter:	Model No:GQ72-190342-E1 Input:100-240V~50/60Hz 1.8A Max Output:19.0V 3.42A 64.98W
Test Voltage:	AC 120V/60Hz
Temperature Range:	0°C ~ +40°C
Software Version:	RTM8.240401.078
Hardware Version:	CO15FGN TV
Note: 1.For more details, please refer to the User's manual of the EUT.	



3 SUMMARY OF TEST RESULT

FCC Part Clause	IC Part Clause	Test Parameter	Verdict	Remark
15.407 (a) 15.407 (e) 2.1049	RSS-247, 6.2 RSS-Gen 6.7	99% , 6dB and 26dB Bandwidth	PASS	
15.407 (a)	RSS-247, 6.2	Maximum Conducted Output Power	PASS	
15.407 (a)	RSS-247, 6.2	PeakPower Spectral Density	PASS	
15.407 (b) 15.209 15.205	RSS-247, 6.2 RSS-Gen 8.9 RSS-Gen 8.10 RSS-Gen 6.13	RadiatedSpurious Emission	PASS	
15.207	RSS-Gen 8.8	Power Line Conducted Emission	PASS	
15.407(a) 15.203	RSS-Gen 6.8	Antenna Application	PASS	
NOTE1:N/A (Not Applicable)				
NOTE2:According to FCC OET KDB 789033, the report use radiated measurements in the restricted frequency bands. In addition, the radiated test is also performed to ensure the emissions emanating from the device cabinet also comply with the applicable limits.				

RELATED SUBMITTAL(S) / GRANT(S):

This submittal(s) (test report) is intended for **FCC ID:2AFZZ-XMTYY03FMG** filing to comply with Section 15.407 of the FCC Part 15, Subpart C Rules.

4 TEST METHODOLOGY

4.1 GENERAL DESCRIPTION OF APPLIED STANDARDS

According to its specifications, the EUT must comply with the requirements of the following standards:

FCC 47 CFR Part 2, Subpart J

FCC 47 CFR Part 15, Subpart E

IC RSS-GEN, Issue 5(04-2018)+A1(03-2019)+A2(02-2021)

IC RSS-247 Issue 3(08-2023)

FCC KDB 662911 D01 Multiple Transmitter Output v02r01

FCC KDB 789033 D2 General UNII Test Procedures New Rules v02r01

4.2 MEASUREMENT EQUIPMENT USED

Conducted Emission Test Equipment

Equipment	Manufacturer	Model No.	Serial No.	Last Cal.	Cal. Interval
EMI Test Receiver	Rohde & Schwarz	ESCI	101384	2024/5/11	1Year
AMN	Rohde & Schwarz	ENV216	101161	2024/5/10	1Year

For Spurious Emissions Test

Equipment	Manufacturer	Model No.	Serial No.	Last Cal.	Cal. Interval
EMI Test Receiver	Rohde & Schwarz	ESU 26	100154	2024/5/10	1Year
Pre-Amplifie	Lunar EM	LNA30M3G-25	J10100000070	2024/5/10	1Year
Bilog Antenna	Schwarzbeck	VULB9163	661	2023/6/2	2 Year
Horn antenna	Schwarzbeck	BBHA9120D	9120D-1177	2023/5/12	2 Year
Pre-Amplifie	SKET	LNPA_0118G-45	SK2019051801	2024/5/10	1Year
Loop Antenna	Schwarzbeck	FMZB1519	1519-012	2023/5/12	2 Year
Spectrum Analyzer	Rohde & Schwarz	FSV40	100967	2024/5/10	1Year
Horn antenna	Schwarzbeck	BBHA9170	9170-399	2023/5/12	2 Year

For other test items:

Equipment	Manufacturer	Model No.	Serial No.	Last Cal.	Cal. Interval
Wideband Radio Communication Tester	R&S	CMW500	171168	2023/9/14	1Year
Frequency Extender	R&S	CMW-Z800A	100430	2023/9/14	1Year
Spectrum Analyzer	R&S	FSV3044	101289	2023/9/14	1Year
Analog Signal Generator	R&S	SMB100A	183237	2023/9/16	1Year
Vector Signal Generator	R&S	SMM100A	101808	2023/9/16	1Year
RF Control Unit(Power Meter)	Tonscend	JS0806-2	22C8060567	2023/9/14	1Year
Temperature&Humidity Chamber	ESPEC	EL-02KA	12107166	2024/5/10	1 Year

4.3 DESCRIPTION OF TEST MODES

The EUT has been tested under its typical operating condition.

The EUT configuration for testing is installed on RF field strength measurement to meet the Commissions requirement and operating in a manner which intends to maximize its emission characteristics in a continuous normal application.

The Transmitter was operated in the normal operating mode. The TX frequency was fixed which was for the purpose of the measurements.

Test of channel included the lowest and middle and highest frequency to perform the test, then record on this report.

Those data rates (802.11a: 54 Mbps; 802.11n(HT20): MCS0; 802.11ac(VHT20): MCS0; 802.11n(HT40): MCS0; 802.11ac(VHT40): MCS0; 802.11ac(VHT80): MCS0;) were used for all test.

Pre-defined engineering program for regulatory testing used to control the EUT for staying in continuous transmitting and receiving mode is programmed.

Wifi 5G with U-NII - 1

Frequency and Channel list for 802.11a, 802.11n (HT20), 802.11ac (VHT20):

Channel	Frequency (MHz)	Channel	Frequency (MHz)	Channel	Frequency (MHz)
36	5180	44	5220		
40	5200	48	5240		

Frequency and Channel list for 802.11n (HT40), 802.11ac (VHT40):

Channel	Frequency (MHz)	Channel	Frequency (MHz)	Channel	Frequency (MHz)
38	5190	46	5230		

Frequency and Channel list for 802.11ac (VHT80):

Channel	Frequency (MHz)	Channel	Frequency (MHz)	Channel	Frequency (MHz)
42	5210				

Test Frequency and Channel for 802.11a, 802.11n (HT20), 802.11ac (VHT20):

Lowest Frequency		Middle Frequency		Highest Frequency	
Channel	Frequency (MHz)	Channel	Frequency (MHz)	Channel	Frequency (MHz)
36	5180	40	5200	48	5240

Test Frequency and channel for 802.11n (HT40), 802.11ac (VHT40):

Lowest Frequency		Middle Frequency		Highest Frequency	
Channel	Frequency (MHz)	Channel	Frequency (MHz)	Channel	Frequency (MHz)
38	5190	N/A	N/A	46	5230

Test Frequency and channel for 802.11ac (VHT80):

Lowest Frequency		Middle Frequency		Highest Frequency	
Channel	Frequency (MHz)	Channel	Frequency (MHz)	Channel	Frequency (MHz)
42	5210	N/A	N/A	N/A	N/A

Wifi 5G with U-NII -2A

Frequency and Channel list 802.11a, 802.11n (HT20), 802.11ac (VHT20):

Channel	Frequency (MHz)	Channel	Frequency (MHz)	Channel	Frequency (MHz)
52	5260	60	5300		
56	5280	64	5320		

Frequency and Channel list for 802.11n (HT40), 802.11ac (VHT40):

Channel	Frequency (MHz)	Channel	Frequency (MHz)	Channel	Frequency (MHz)
54	5270				
62	5310				

Frequency and Channel list for 802.11ac (VHT80):

Channel	Frequency (MHz)	Channel	Frequency (MHz)	Channel	Frequency (MHz)
58	5290				

Test Frequency and Channel for 802.11a, 802.11n (HT20), 802.11ac (VHT20):

Lowest Frequency		Middle Frequency		Highest Frequency	
Channel	Frequency (MHz)	Channel	Frequency (MHz)	Channel	Frequency (MHz)
52	5260	56	5280	64	5320

Test Frequency and channel for 802.11n (HT40), 802.11ac (VHT40):

Lowest Frequency		Middle Frequency		Highest Frequency	
Channel	Frequency (MHz)	Channel	Frequency (MHz)	Channel	Frequency (MHz)
54	5270	N/A	N/A	62	5310

Test Frequency and channel for 802.11ac (VHT80)::

Lowest Frequency		Middle Frequency		Highest Frequency	
Channel	Frequency (MHz)	Channel	Frequency (MHz)	Channel	Frequency (MHz)
58	5290				

Wifi 5G with U-NII -2C

Frequency and Channel list for 802.11a, 802.11n (HT20), 802.11ac (VHT20):

Channel	Frequency (MHz)	Channel	Frequency (MHz)	Channel	Frequency (MHz)
100	5500	116	5580	132	5660
104	5520	120	5600	136	5680
108	5540	124	5620	140	5700
112	5560	128	5640		

Frequency and Channel list for 802.11n (HT40), 802.11ac (VHT40):

Channel	Frequency (MHz)	Channel	Frequency (MHz)	Channel	Frequency (MHz)
102	5510	118	5590	134	5670
110	5550	126	5630		

Frequency and Channel list for 802.11ac (VHT80):

Channel	Frequency (MHz)	Channel	Frequency (MHz)	Channel	Frequency (MHz)
106	5530	122	5610		

Test Frequency and Channel for 802.11a, 802.11n (HT20), 802.11ac (VHT20):

Lowest Frequency		Middle Frequency		Highest Frequency	
Channel	Frequency (MHz)	Channel	Frequency (MHz)	Channel	Frequency (MHz)
100	5500	120	5600	140	5700

Test Frequency and channel for 802.11n (HT40), 802.11ac (VHT40):

Lowest Frequency		Middle Frequency		Highest Frequency	
Channel	Frequency (MHz)	Channel	Frequency (MHz)	Channel	Frequency (MHz)
102	5510			134	5670

Test Frequency and channel for 802.11ac (VHT80):

Lowest Frequency		Middle Frequency		Highest Frequency	
Channel	Frequency (MHz)	Channel	Frequency (MHz)	Channel	Frequency (MHz)
106	5530				

Wifi 5G with U-NII -3

Frequency and Channel list for 802.11a, 802.11n (HT20), 802.11ac (VHT20):

Channel	Frequency (MHz)	Channel	Frequency (MHz)	Channel	Frequency (MHz)
149	5745	157	5785	165	5825
153	5765	161	5805		

Frequency and Channel list for 802.11n (HT40), 802.11ac (VHT40):

Channel	Frequency (MHz)	Channel	Frequency (MHz)	Channel	Frequency (MHz)
151	5755	159	5795		

Frequency and Channel list for 802.11ac (VHT80):

Channel	Frequency (MHz)	Channel	Frequency (MHz)	Channel	Frequency (MHz)
155	5775				

Test Frequency and Channel for 802.11a, 802.11n (HT20), 802.11ac (VHT20):

Lowest Frequency		Middle Frequency		Highest Frequency	
Channel	Frequency (MHz)	Channel	Frequency (MHz)	Channel	Frequency (MHz)
149	5745	157	5785	165	5825

Test Frequency and channel for 802.11n (HT40), 802.11ac (VHT40):

Lowest Frequency		Middle Frequency		Highest Frequency	
Channel	Frequency (MHz)	Channel	Frequency (MHz)	Channel	Frequency (MHz)
151	5755	N/A	N/A	159	5795

Test Frequency and channel for 802.11ac (VHT80):

Lowest Frequency		Middle Frequency		Highest Frequency	
Channel	Frequency (MHz)	Channel	Frequency (MHz)	Channel	Frequency (MHz)
155	5775				

Multi-antenna correlation:

<input checked="" type="checkbox"/>	Transmit Signals are Correlated
	Directional gain = $10 \log[(10^{G1/20} + 10^{G2/20} + \dots + 10^{GN/20})^2 / N_{ANT}]$ dBi
<input type="checkbox"/>	All Transmit Signals are Completely Uncorrelated
	Directional gain = $10 \log[(10^{G1/10} + 10^{G2/10} + \dots + 10^{GN/10}) / N_{ANT}]$ dBi

Directional gain = $10 \log [(10^{2.97/20} + 10^{2.52/20})^2/2]$ dBi=5.76 dBi

5 FACILITIES AND ACCREDITATIONS

5.1 FACILITIES

All measurement facilities used to collect the measurement data are located at:

EMTEK (Shenzhen) Co., Ltd.

Building 69, Majialong Industry Zone District, Nanshan District, Shenzhen, China

The sites are constructed in conformance with the requirements of ANSI C63.7, ANSI C63.4 and CISPR Publication 22.

5.2 EQUIPMENT

Radiated emissions are measured with one or more of the following types of linearly polarized antennas: tuned dipole, biconical, log periodic, bi-log, and/or ridged waveguide, horn. Spectrum analyzers with preselectors and quasi-peak detectors are used to perform radiated measurements.

Conducted emissions are measured with Line Impedance Stabilization Networks and EMI Test Receivers.

Calibrated wideband preamplifiers, coaxial cables, and coaxial attenuators are also used for making measurements.

All receiving equipment conforms to CISPR Publication 16-1, "Radio Interference Measuring Apparatus and Measurement Methods."

5.3 LABORATORY ACCREDITATIONS AND LISTINGS

Site Description

EMC Lab. : **Accredited by CNAS**
 The Certificate Registration Number is L2291.
 The Laboratory has been assessed and proved to be in compliance with CNAS-CL01 (identical to ISO/IEC 17025:2017)

Accredited by FCC
 Designation Number: CN1204
 Test Firm Registration Number: 882943

Accredited by A2LA
 The Certificate Number is 4321.01.

Accredited by Industry Canada
 The Conformity Assessment Body Identifier is CN0008

Name of Firm : EMTEK (SHENZHEN) CO., LTD.

Site Location : Building 69, Majialong Industry Zone,
 Nanshan District, Shenzhen, Guangdong, China

6 TEST SYSTEM UNCERTAINTY

The following measurement uncertainty levels have been estimated for tests performed on the apparatus:

Test Parameter	Measurement Uncertainty
Frequency error	$\pm 20\text{Hz}$
Occupied Bandwidth	$\pm 0.5\text{KHz}$
Transmitter output power	$\pm 0.6\text{dB}$
Conducted spurious emissions	$\pm 3.2\text{dB}$
Radiated spurious emissions	$\pm 4.5\text{dB}$
Temperature	$\pm 1.2^\circ\text{C}$
Humidity	$\pm 3\%$
DC voltages	$\pm 0.25\text{V}$
Time	$\pm 1\%$

Measurement Uncertainty for a level of Confidence of 95%

7 SETUP OF EQUIPMENT UNDER TEST

7.1 RADIO FREQUENCY TEST SETUP

The WLAN component's antenna ports(s) of the EUT are connected to the measurement instrument per an appropriate attenuator. The EUT is controlled by PC/software to emit the specified signals for the purpose of measurements.

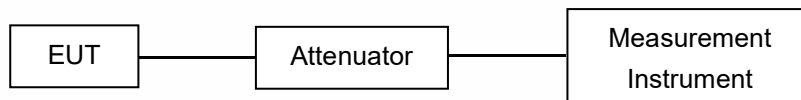

7.2 RADIO FREQUENCY TEST SETUP

The test site semi-anechoic chamber has met the requirement of NSA tolerance 4 dB according to the standards: ANSI C63.10. The test distance is 3m. The setup is according to the requirements in Section 13.1.4.1 of ANSI C63.10-2013 and CAN/CSA-CEI/IEC CISPR 22.

Below 30MHz:

The EUT is placed on a turntable 0.8 meters above the ground in the chamber, 3 meter away from the antenna (loop antenna). The Antenna should be positioned with its plane vertical at the specified distance from the EUT and rotated about its vertical axis for maximum response at each azimuth about the EUT. The center of the loop shall be 1 m above the ground. For certain applications, the loop antenna plane may also need to be positioned horizontally at the specified distance from the EUT.

Above 30MHz:

The EUT is placed on a turntable 0.8 meters above the ground in the chamber, 3 meter away from the antenna. The maximal emission value is acquired by adjusting the antenna height, polarisation and turntable azimuth. Normally, the height range of antenna is 1 m to 4 m, the azimuth range of turntable is 0° to 360°, and the receive antenna has two polarizations Vertical (V) and Horizontal (H).

Above 1GHz:

(Note: the FCC's permission to use 1.5m as an alternative per TCBC Conf call of Dec. 2, 2014.)

The EUT is placed on a turntable 1.5 meters above the ground in the chamber, 3 meter away from the antenna. The maximal emission value is acquired by adjusting the antenna height, polarisation and turntable azimuth. Normally, the height range of antenna is 1 m to 4 m, the azimuth range of turntable is 0° to 360°, and the receive antenna has two polarizations Vertical (V) and Horizontal (H).

(a) Radiated Emission Test Set-Up, Frequency Below 30MHz

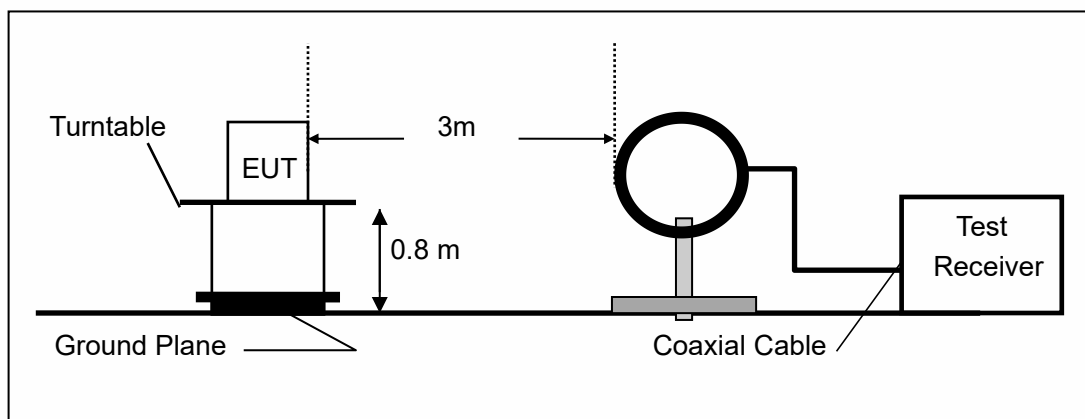

(b) Radiated Emission Test Set-Up, Frequency Below 1000MHz

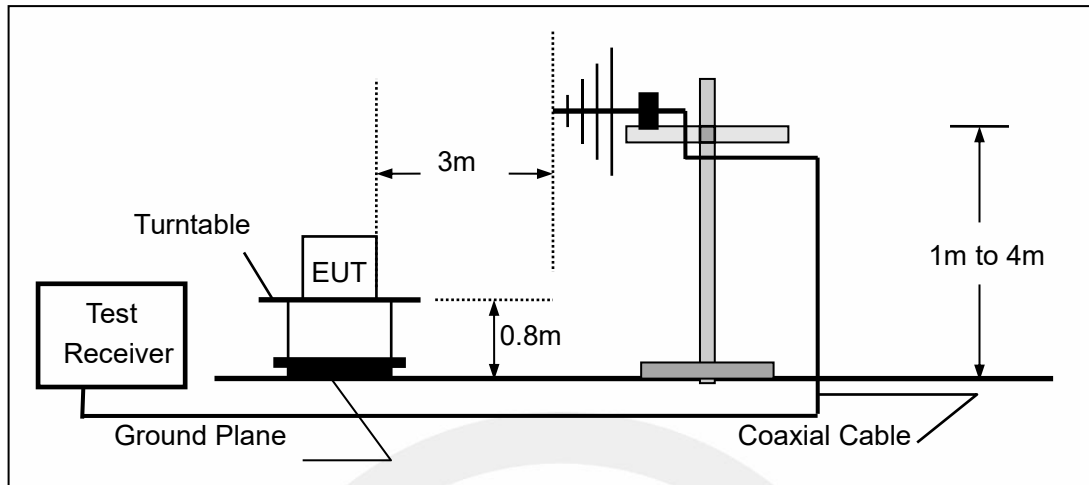

(c) Radiated Emission Test Set-Up, Frequency above 1000MHz

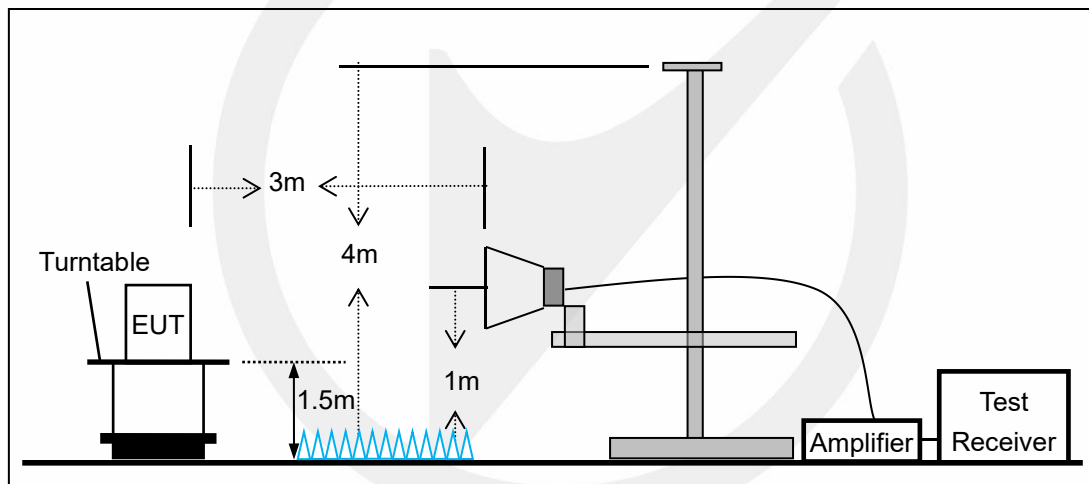

7.3 CONDUCTED EMISSION TEST SETUP

The mains cable of the EUT (maybe per AC/DC Adapter) must be connected to LISN. The LISN shall be placed 0.8 m from the boundary of EUT and bonded to a ground reference plane for LISN mounted on top of the ground reference plane. This distance is between the closest points of the LISN and the EUT. All other units of the EUT and associated equipment shall be at least 0.8m from the LISN.

Ground connections, where required for safety purposes, shall be connected to the reference ground point of the LISN and, where not otherwise provided or specified by the manufacturer, shall be of same length as the mains cable and run parallel to the mains connection at a separation distance of not more than 0.1 m.

According to the requirements in Section 13.1.4.1 of ANSI C63.10-2013 Conducted emissions from the EUT measured in the frequency range between 0.15 MHz and 30 MHz using CISPR Quasi-Peak and average detector mode.

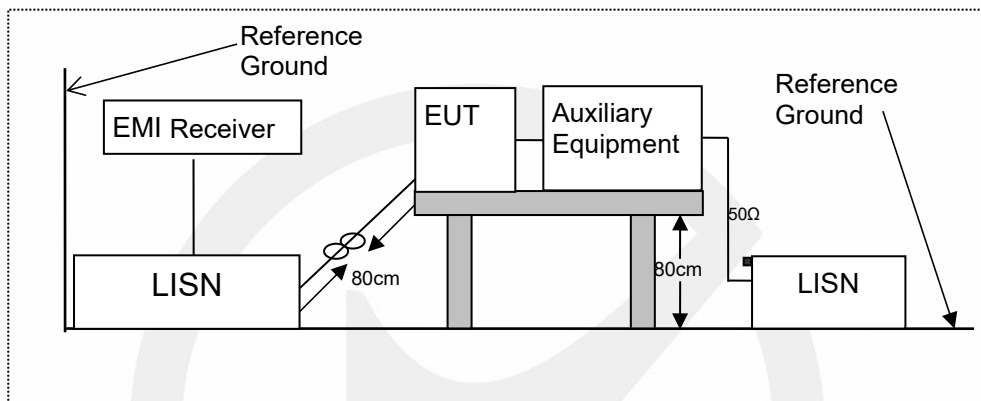

7.4 BLOCK DIAGRAM CONFIGURATION OF TEST SYSTEM

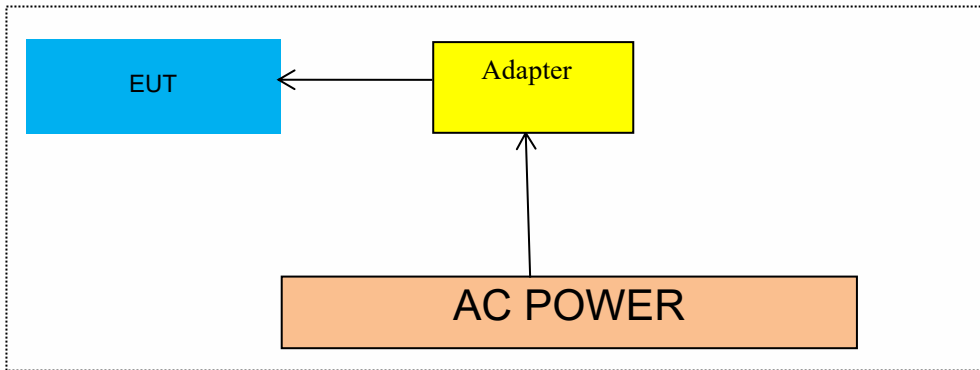

7.5 SUPPORT EQUIPMENT

EUT Cable List and Details			
Cable Description	Length (m)	Shielded/Unshielded	With / Without Ferrite
/	/	/	/

Auxiliary Cable List and Details			
Cable Description	Length (m)	Shielded/Unshielded	With / Without Ferrite
/	/	/	/

Auxiliary Equipment List and Details			
Description	Manufacturer	Model	Serial Number
/	/	/	/

Notes:

- 1.All the equipment/cables were placed in the worst-case configuration to maximize the emission during the test.
- 2.Grounding was established in accordance with the manufacturer’s requirements and conditions for the intended use.

8 TEST REQUIREMENTS

8.1 BANDWIDTH MEASUREMENT

8.1.1 Applicable Standard

According to FCC Part 15.407(a)(1) for UNII Band I
According to FCC Part 15.407(a)(2) for UNII Band II-A and UNII Band II-C
According to FCC Part 15.407(a)(3) for UNII Band III
According to FCC Part 15.407(e) for UNII Band III
According to 789033 D02 Section II(C)
According to 789033 D02 Section II(D)
According to RSS-Gen6.6, RSS 247, 6.2

8.1.2 Conformance Limit

The 26dB bandwidth is used to determine the conducted power limits.
Within the 5.725-5.85 GHz band, the minimum 6 dB bandwidth of U-NII devices shall be at least 500 kHz.

8.1.3 Test Configuration

Test according to clause 7.1 radio frequency test setup

8.1.4 Test Procedure

According to 789033 D02 v02r01 section C&D, the following is the measurement procedure.

1. Emission Bandwidth (EBW)

- a) Set RBW = approximately 1% of the emission bandwidth.
- b) Set the VBW > RBW.
- c) Detector = Peak.
- d) Trace mode = max hold.
- e) Measure the maximum width of the emission that is 26 dB down from the maximum of the emission. Compare this with the RBW setting of the analyzer. Readjust RBW and repeat measurement as needed until the RBW/EBW ratio is approximately 1%.

2. Minimum Emission Bandwidth for the band 5.725-5.85 GHz

Section 15.407(e) specifies the minimum 6 dB emission bandwidth of at least 500 KHz for the band 5.715-5.85 GHz. The following procedure shall be used for measuring this bandwidth:

- a) Set RBW = 100 kHz.
- b) Set the video bandwidth (VBW) $\geq 3 \times$ RBW.
- c) Detector = Peak.
- d) Trace mode = max hold.
- e) Sweep = auto couple.
- f) Allow the trace to stabilize.
- g) Measure the maximum width of the emission that is constrained by the frequencies associated with the two outermost amplitude points (upper and lower frequencies) that are attenuated by 6 dB relative to the maximum level measured in the fundamental emission.

Note: The automatic bandwidth measurement capability of a spectrum analyzer or EMI receiver may be employed if it implements the functionality described above.

D. 99 Percent Occupied Bandwidth

The 99-percent occupied bandwidth is the frequency bandwidth such that, below its lower and above its upper frequency limits, the mean powers are each equal to 0.5 % of the total mean power of the given emission. Measurement of the 99-percent occupied bandwidth is required only as a condition for using the optional band-edge measurement techniques described in section II.G.3.d). Measurements of 99-percent occupied bandwidth may also optionally be used in lieu of the EBW to 789033 D02 v01r02 General UNII Test Procedures New Rules v01 define the minimum frequency range over which the spectrum is integrated when measuring maximum conducted output power as described in section II.E.

However, the EBW must be measured to determine bandwidth dependent limits on maximum conducted output power in accordance with 15.407(a).

The following procedure shall be used for measuring (99 %) power bandwidth:

1. Set center frequency to the nominal EUT channel center frequency.
2. Set span = 1.5 times to 5.0 times the OBW.
3. Set RBW = 1 % to 5 % of the OBW
4. Set VBW $\geq 3 \cdot$ RBW
5. Video averaging is not permitted. Where practical, a sample detection and single sweep mode shall be used. Otherwise, peak detection and max hold mode (until the trace stabilizes) shall be used.
6. Use the 99 % power bandwidth function of the instrument (if available).
7. If the instrument does not have a 99 % power bandwidth function, the trace data points are recovered and directly summed in power units. The recovered amplitude data points, beginning at the lowest frequency, are placed in a running sum until 0.5 % of the total is reached; that frequency is recorded as the lower frequency. The process is repeated until 99.5 % of the total is reached; that frequency is recorded as the upper frequency. The 99% occupied bandwidth is the difference between these two frequencies.



8.1.5 Test Results

Temperature:	25°C
Relative Humidity:	45%
ATM Pressure:	1011 mbar

Note: N/A

Emission Bandwidth

TestMode	Antenna	Frequency[MHz]	26db EBW [MHz]	FL[MHz]	FH[MHz]	Limit[MHz]	Verdict
11A	Ant1	5180	20.08	5170.00	5190.08	---	---
	Ant2	5180	20.00	5170.00	5190.00	---	---
	Ant1	5200	20.44	5189.76	5210.20	---	---
	Ant2	5200	20.16	5190.00	5210.16	---	---
	Ant1	5240	20.12	5229.92	5250.04	---	---
	Ant2	5240	20.12	5229.92	5250.04	---	---
	Ant1	5260	20.16	5249.80	5269.96	---	---
	Ant2	5260	20.28	5249.84	5270.12	---	---
	Ant1	5280	20.24	5269.88	5290.12	---	---
	Ant2	5280	20.24	5269.96	5290.20	---	---
	Ant1	5320	20.16	5309.84	5330.00	---	---
	Ant2	5320	20.08	5309.92	5330.00	---	---
	Ant1	5500	20.12	5489.92	5510.04	---	---
	Ant2	5500	20.00	5489.96	5509.96	---	---
	Ant1	5580	20.48	5569.68	5590.16	---	---
	Ant2	5580	20.36	5569.80	5590.16	---	---
	Ant1	5700	20.04	5689.96	5710.00	---	---
	Ant2	5700	20.12	5689.92	5710.04	---	---
	Ant1	5745	20.24	5734.88	5755.12	---	---
	Ant2	5745	20.28	5734.76	5755.04	---	---
	Ant1	5785	20.16	5774.92	5795.08	---	---
	Ant2	5785	20.00	5775.00	5795.00	---	---
	Ant1	5825	20.28	5814.84	5835.12	---	---
	Ant2	5825	20.00	5815.04	5835.04	---	---
11N20MIMO	Ant1	5180	20.44	5169.76	5190.20	---	---
	Ant2	5180	20.36	5169.76	5190.12	---	---
	Ant1	5200	20.48	5189.72	5210.20	---	---
	Ant2	5200	20.32	5189.80	5210.12	---	---
	Ant1	5240	20.36	5229.80	5250.16	---	---
	Ant2	5240	20.36	5229.76	5250.12	---	---
	Ant1	5260	20.44	5249.72	5270.16	---	---
	Ant2	5260	20.52	5249.68	5270.20	---	---
	Ant1	5280	20.40	5269.72	5290.12	---	---
	Ant2	5280	20.32	5269.80	5290.12	---	---
	Ant1	5320	20.52	5309.68	5330.20	---	---
	Ant2	5320	20.36	5309.76	5330.12	---	---
	Ant1	5500	20.32	5489.80	5510.12	---	---
	Ant2	5500	20.40	5489.72	5510.12	---	---
	Ant1	5580	20.36	5569.76	5590.12	---	---
	Ant2	5580	20.40	5569.76	5590.16	---	---
	Ant1	5700	20.28	5689.84	5710.12	---	---
	Ant2	5700	20.36	5689.80	5710.16	---	---

	Ant1	5745	20.32	5734.84	5755.16	---	---	
	Ant2	5745	20.32	5734.80	5755.12	---	---	
	Ant1	5785	20.40	5774.76	5795.16	---	---	
	Ant2	5785	20.36	5774.76	5795.12	---	---	
	Ant1	5825	20.36	5814.84	5835.20	---	---	
	Ant2	5825	20.36	5814.80	5835.16	---	---	
11N40MIMO	Ant1	5190	42.00	5169.04	5211.04	---	---	
	Ant2	5190	40.64	5169.68	5210.32	---	---	
	Ant1	5230	42.00	5209.04	5251.04	---	---	
	Ant2	5230	40.88	5209.60	5250.48	---	---	
	Ant1	5270	42.32	5248.88	5291.20	---	---	
	Ant2	5270	41.04	5249.52	5290.56	---	---	
	Ant1	5310	41.92	5288.96	5330.88	---	---	
	Ant2	5310	41.44	5289.12	5330.56	---	---	
	Ant1	5510	45.44	5485.76	5531.20	---	---	
	Ant2	5510	40.96	5489.52	5530.48	---	---	
	Ant1	5550	42.96	5528.72	5571.68	---	---	
	Ant2	5550	41.36	5529.36	5570.72	---	---	
	Ant1	5670	42.88	5648.48	5691.36	---	---	
	Ant2	5670	41.44	5649.44	5690.88	---	---	
	Ant1	5755	42.00	5733.96	5775.96	---	---	
	Ant2	5755	40.88	5734.68	5775.56	---	---	
	Ant1	5795	42.08	5774.12	5816.20	---	---	
	Ant2	5795	40.88	5774.44	5815.32	---	---	
	11AC20MIMO	Ant1	5180	20.48	5169.80	5190.28	---	---
		Ant2	5180	20.24	5169.76	5190.00	---	---
Ant1		5200	20.48	5189.76	5210.24	---	---	
Ant2		5200	20.28	5189.88	5210.16	---	---	
Ant1		5240	27.04	5227.08	5254.12	---	---	
Ant2		5240	25.88	5227.36	5253.24	---	---	
Ant1		5260	27.36	5246.76	5274.12	---	---	
Ant2		5260	27.04	5246.76	5273.80	---	---	
Ant1		5280	27.00	5266.80	5293.80	---	---	
Ant2		5280	27.12	5266.80	5293.92	---	---	
Ant1		5320	28.60	5305.56	5334.16	---	---	
Ant2		5320	27.08	5307.36	5334.44	---	---	
Ant1		5500	20.64	5489.64	5510.28	---	---	
Ant2		5500	20.36	5489.76	5510.12	---	---	
Ant1		5580	25.84	5567.36	5593.20	---	---	
Ant2		5580	26.60	5567.08	5593.68	---	---	
Ant1		5700	24.20	5689.00	5713.20	---	---	
Ant2		5700	24.80	5689.32	5714.12	---	---	
Ant1		5745	25.80	5732.40	5758.20	---	---	
Ant2		5745	26.08	5732.64	5758.72	---	---	
Ant1		5785	20.32	5774.84	5795.16	---	---	
Ant2		5785	20.08	5774.92	5795.00	---	---	
Ant1		5825	20.32	5814.84	5835.16	---	---	
Ant2		5825	20.04	5814.96	5835.00	---	---	
11AC40MIMO		Ant1	5190	48.16	5167.68	5215.84	---	---
		Ant2	5190	40.96	5169.76	5210.72	---	---
		Ant1	5230	43.36	5209.04	5252.40	---	---
		Ant2	5230	41.04	5209.52	5250.56	---	---
		Ant1	5270	41.52	5249.28	5290.80	---	---
		Ant2	5270	40.88	5249.60	5290.48	---	---
	Ant1	5310	41.52	5289.28	5330.80	---	---	

	Ant2	5310	40.88	5289.68	5330.56	---	---
	Ant1	5510	46.56	5487.76	5534.32	---	---
	Ant2	5510	41.04	5489.60	5530.64	---	---
	Ant1	5550	41.60	5529.20	5570.80	---	---
	Ant2	5550	40.96	5529.52	5570.48	---	---
	Ant1	5670	41.28	5649.36	5690.64	---	---
	Ant2	5670	40.40	5649.84	5690.24	---	---
	Ant1	5755	41.28	5734.36	5775.64	---	---
	Ant2	5755	40.48	5734.68	5775.16	---	---
	Ant1	5795	41.36	5774.36	5815.72	---	---
	Ant2	5795	40.40	5774.76	5815.16	---	---
11AC80MIMO	Ant1	5210	83.52	5167.60	5251.12	---	---
	Ant2	5210	81.60	5169.20	5250.80	---	---
	Ant1	5290	83.84	5247.28	5331.12	---	---
	Ant2	5290	81.60	5249.20	5330.80	---	---
	Ant1	5530	84.32	5487.12	5571.44	---	---
	Ant2	5530	81.44	5489.20	5570.64	---	---
	Ant1	5610	81.92	5569.04	5650.96	---	---
	Ant2	5610	81.12	5569.36	5650.48	---	---
	Ant1	5775	82.24	5733.88	5816.12	---	---
	Ant2	5775	81.28	5734.20	5815.48	---	---

11A_Ant1_5180

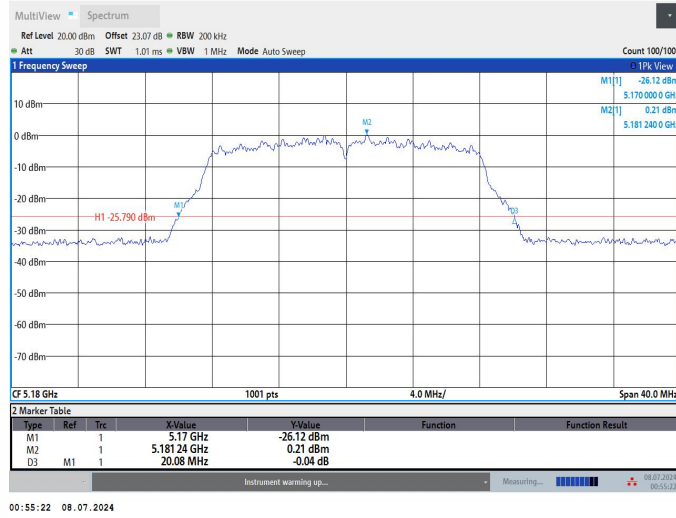

11A_Ant2_5180

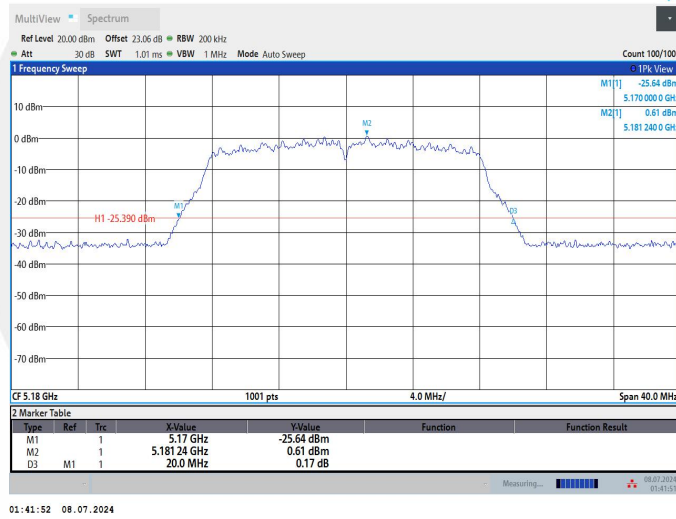

11A_Ant1_5200

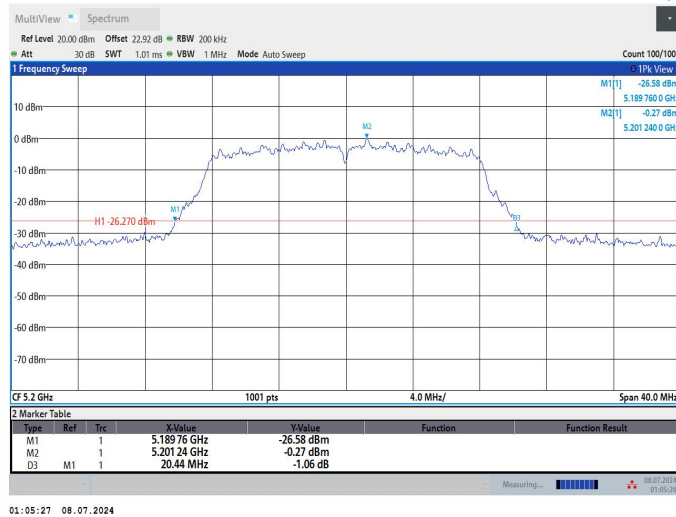

11A_Ant2_5200

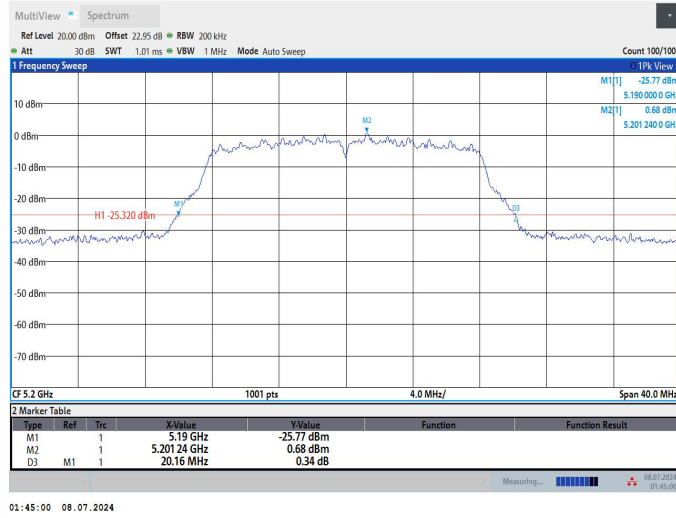

01:45:00 08.07.2024

11A_Ant1_5240

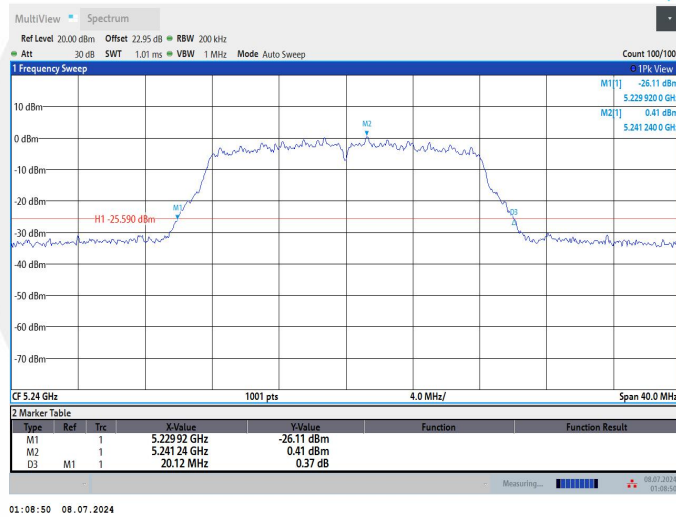

01:08:50 08.07.2024

11A_Ant2_5240

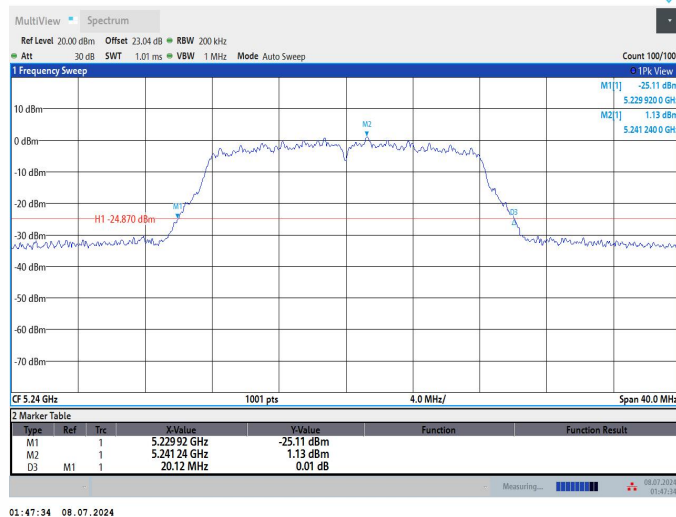

01:47:34 08.07.2024

11A_Ant1_5260

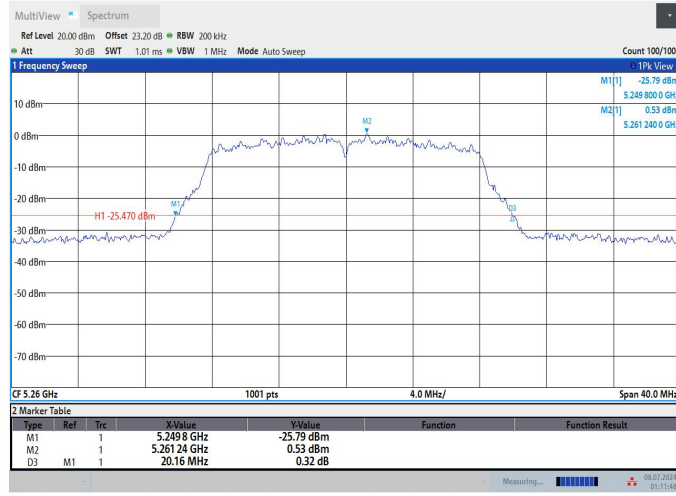

01:11:48 08.07.2024

11A_Ant2_5260

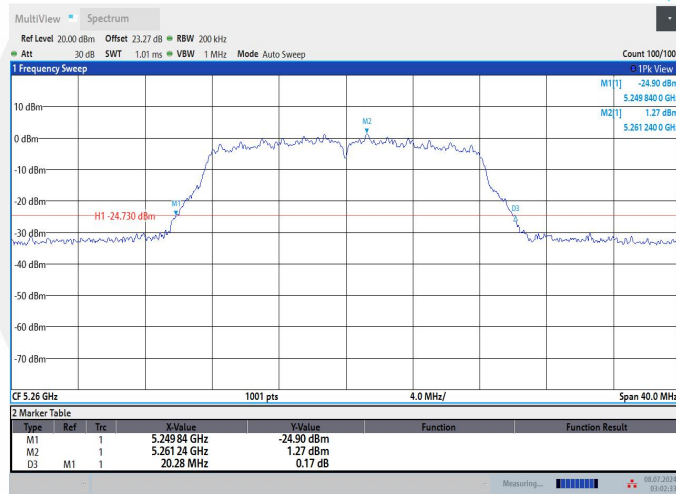

03:02:33 08.07.2024

11A_Ant1_5280

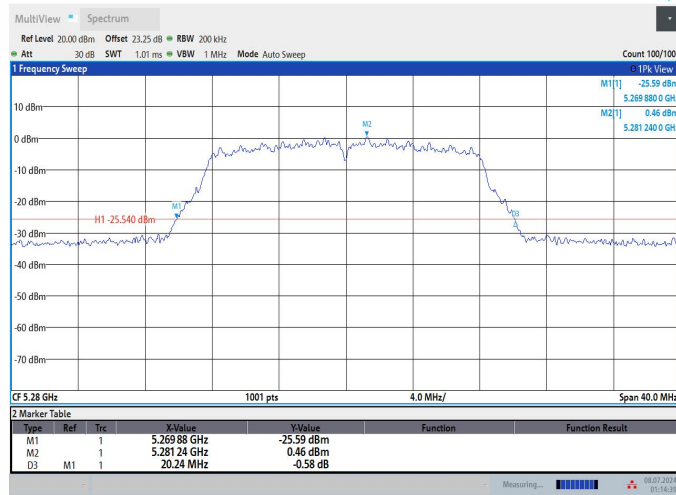

01:14:39 08.07.2024

11A_Ant2_5280

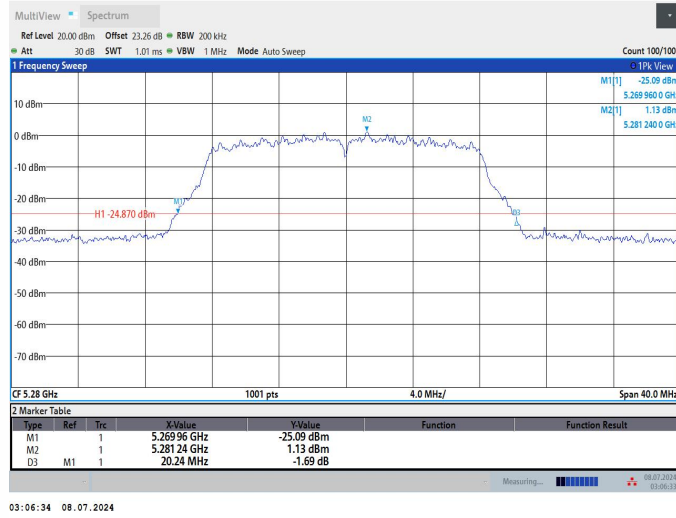

11A_Ant1_5320

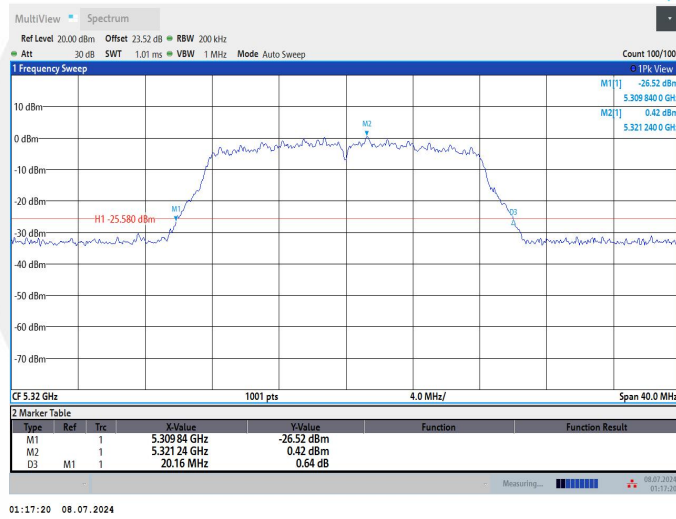

11A_Ant2_5320

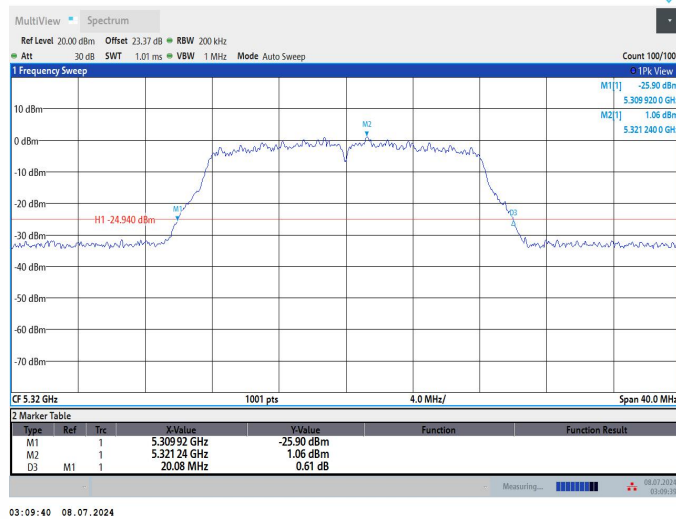

11A_Ant1_5500

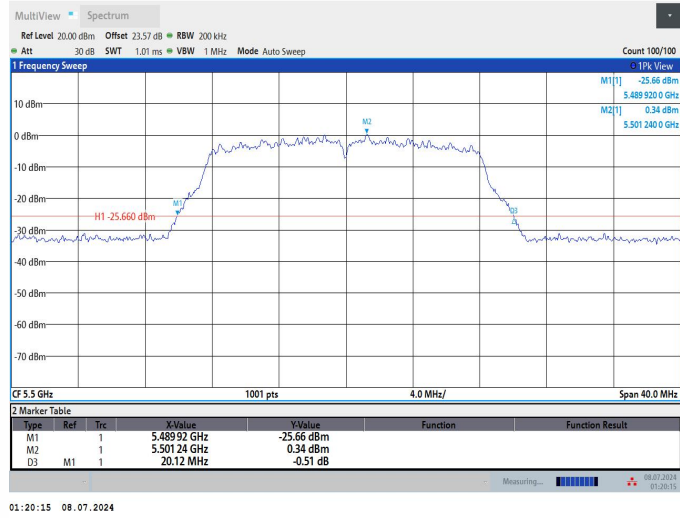

01:20:15 08.07.2024

11A_Ant2_5500

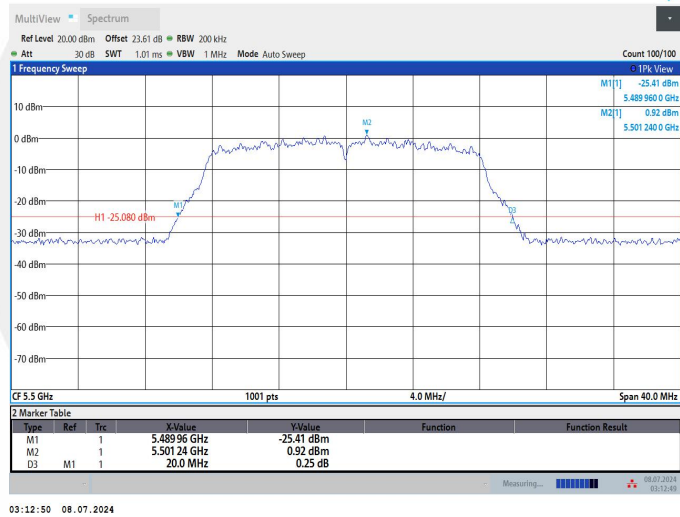

03:12:50 08.07.2024

11A_Ant1_5580

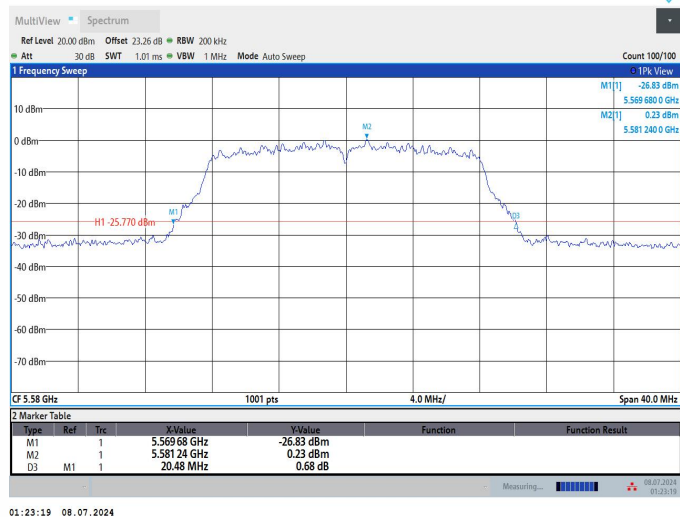

01:23:19 08.07.2024

11A_Ant2_5580

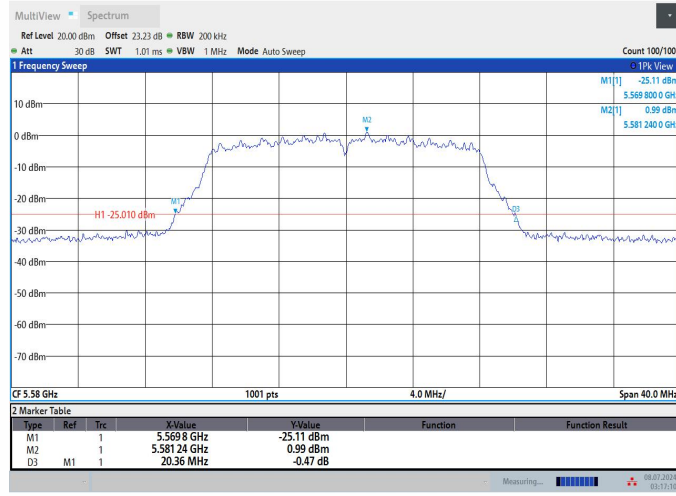

03:17:11 08.07.2024

11A_Ant1_5700

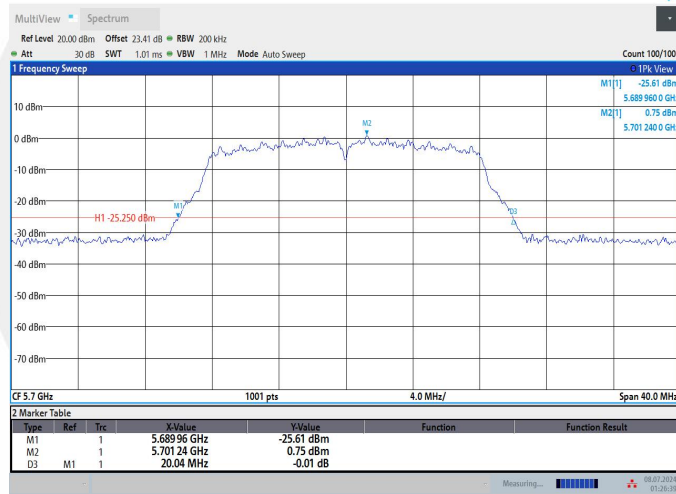

01:26:39 08.07.2024

11A_Ant2_5700

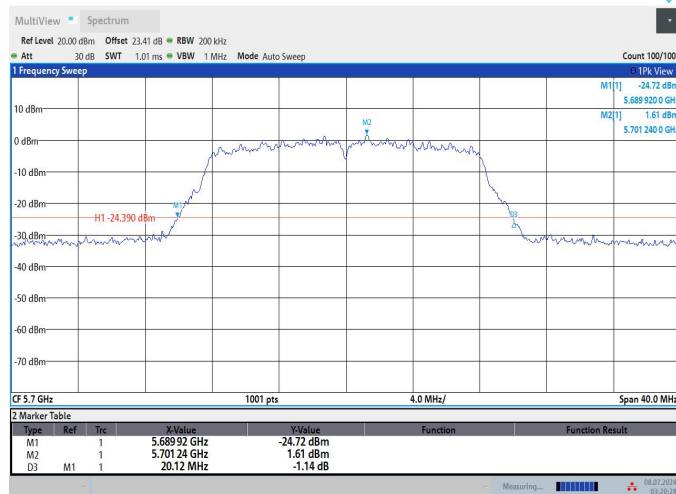

03:20:28 08.07.2024

11A_Ant1_5745

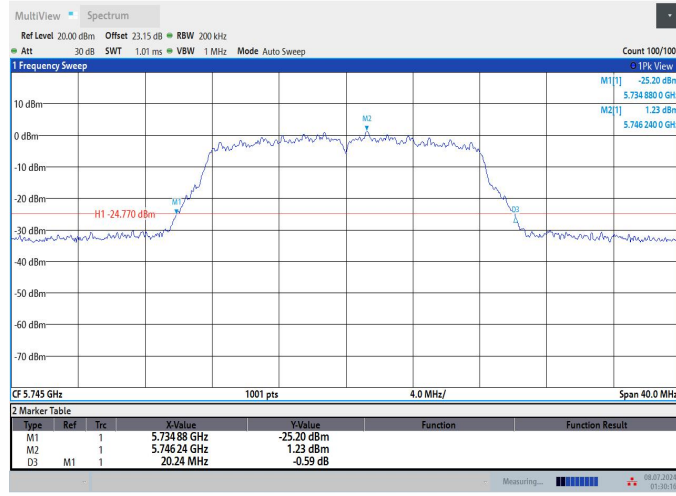

01:30:16 08.07.2024

11A_Ant2_5745

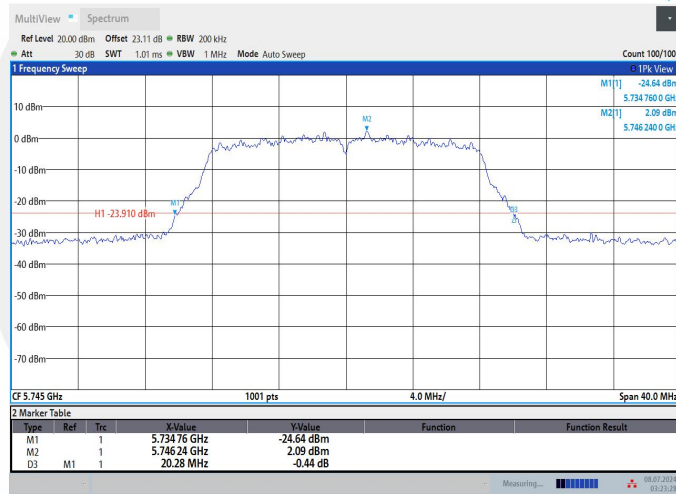

03:23:28 08.07.2024

11A_Ant1_5785

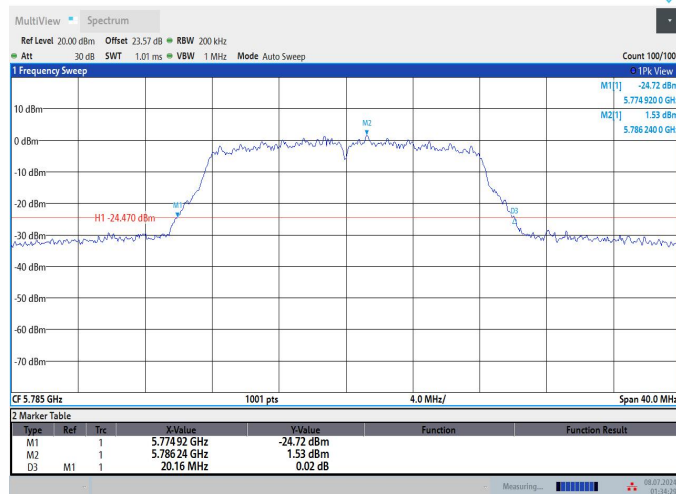

01:34:29 08.07.2024

11A_Ant2_5785

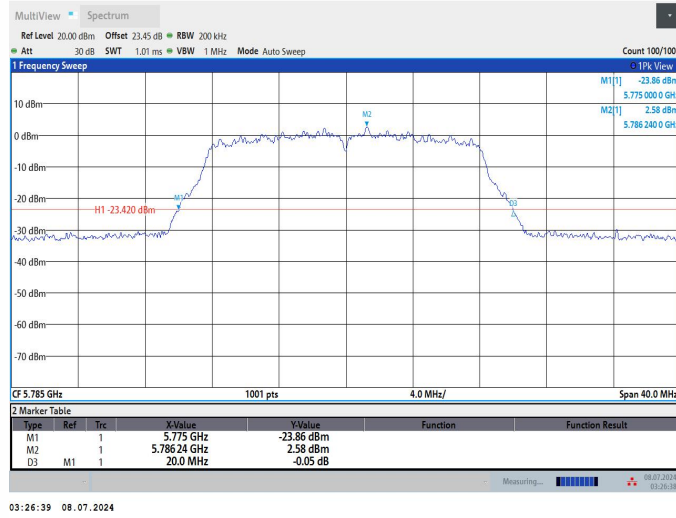

11A_Ant1_5825

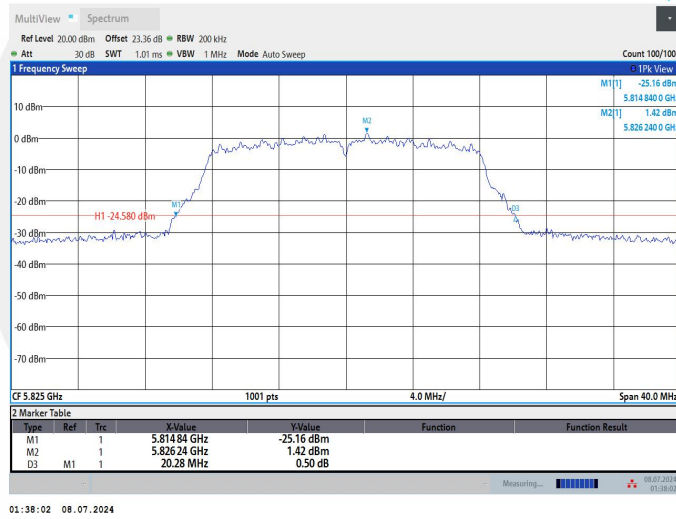

11A_Ant2_5825

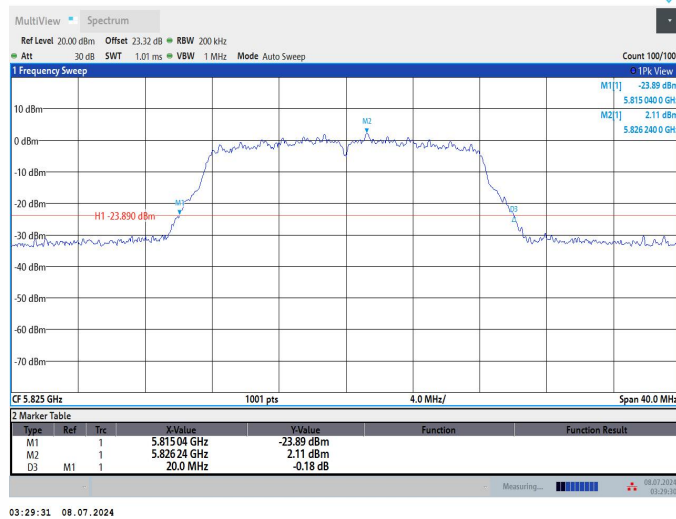

11N20MIMO_Ant1_5180

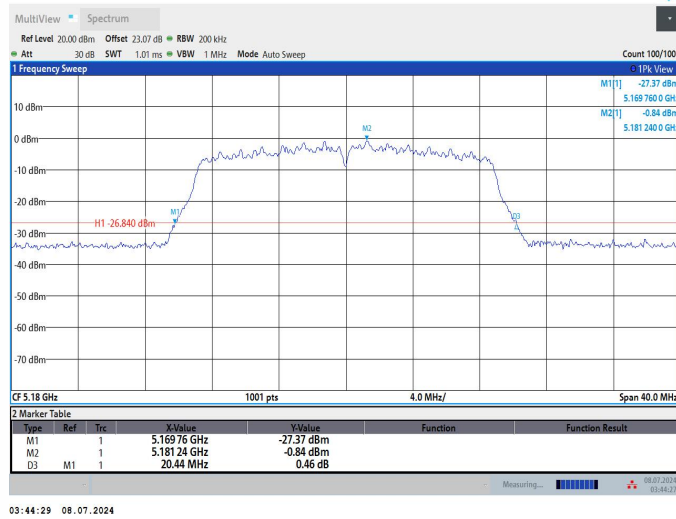

11N20MIMO_Ant2_5180

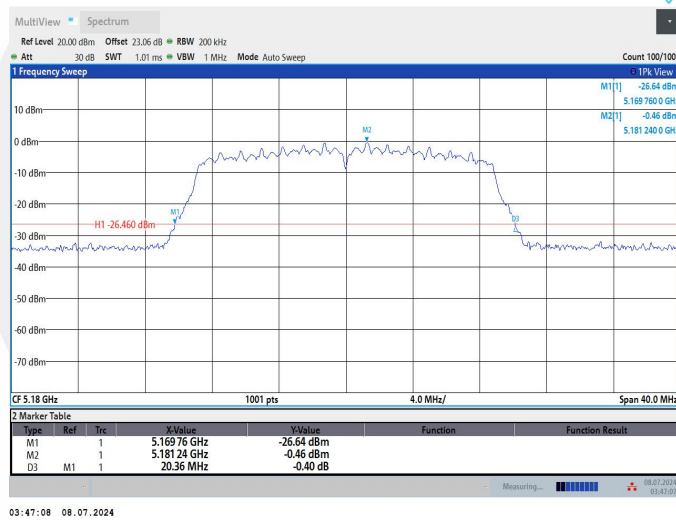

11N20MIMO_Ant1_5200

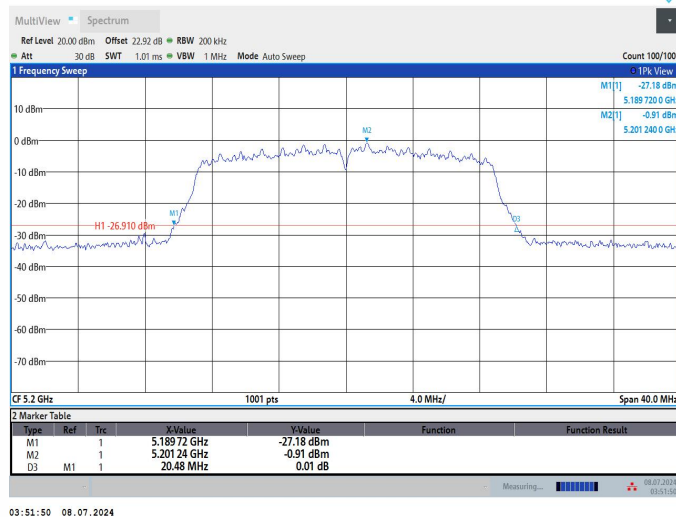

11N20MIMO_Ant2_5200

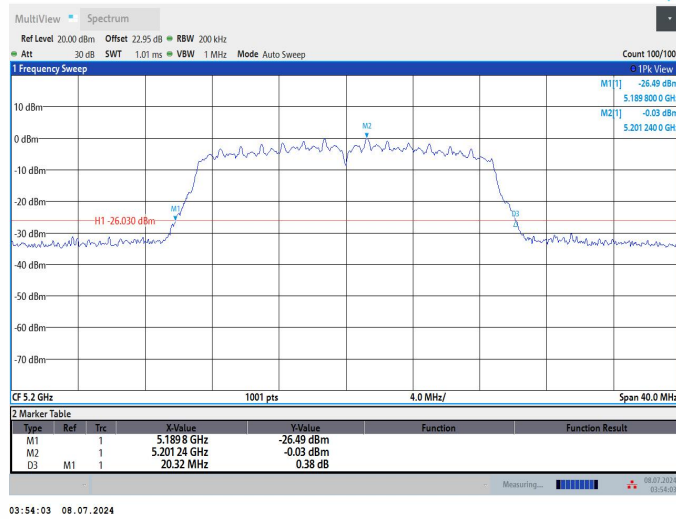

03:54:03 08.07.2024

11N20MIMO_Ant1_5240

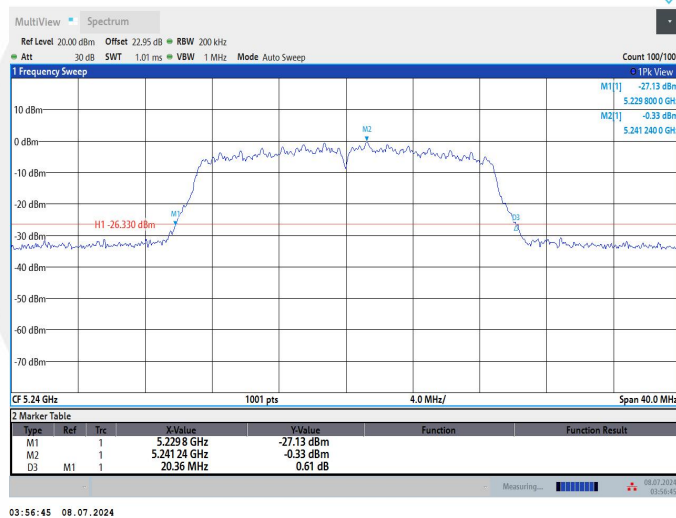

03:56:45 08.07.2024

11N20MIMO_Ant2_5240

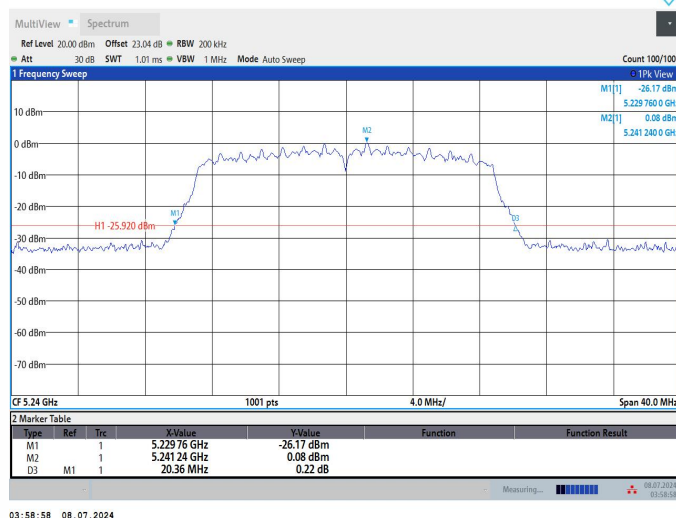

03:58:58 08.07.2024

11N20MIMO_Ant1_5260

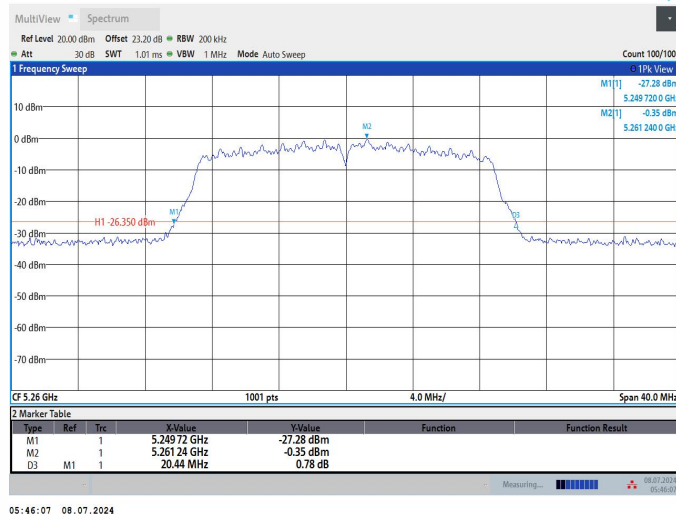

05:46:07 08.07.2024

11N20MIMO_Ant2_5260

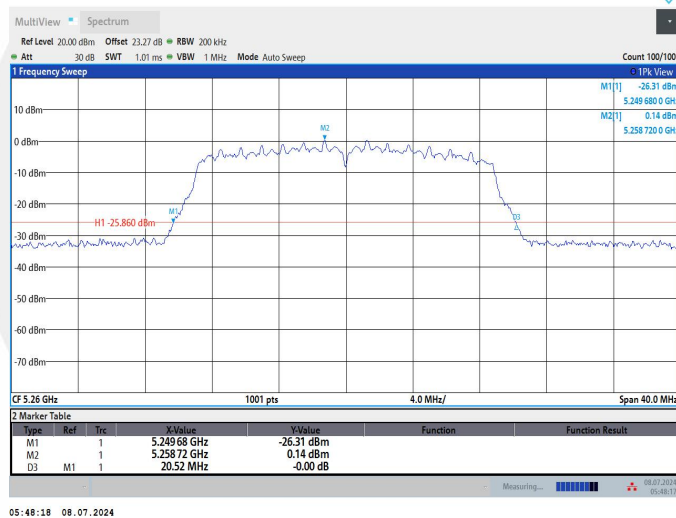

05:48:18 08.07.2024

11N20MIMO_Ant1_5280

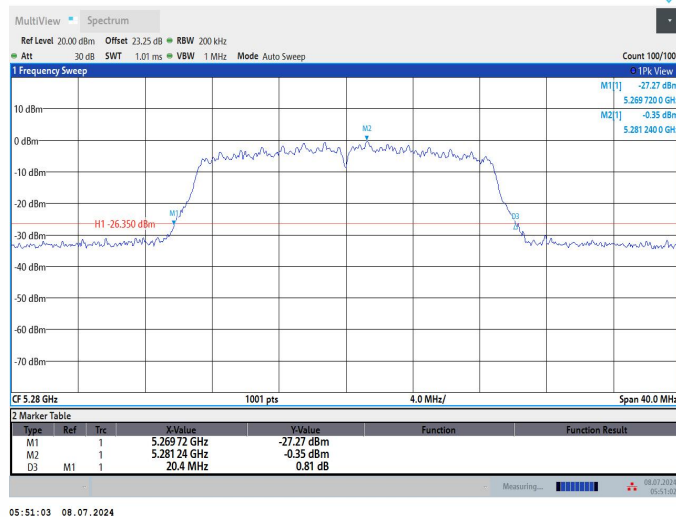

05:51:03 08.07.2024