



FCC RF Test Report

APPLICANT : Xiaomi Communications Co., Ltd.
EQUIPMENT : Mobile Phone
BRAND NAME : XIAOMI
MODEL NAME : M1906F9SH
FCC ID : 2AFZZ-XMSF9SH
STANDARD : FCC Part 15 Subpart E §15.407
CLASSIFICATION : (NII) Unlicensed National Information Infrastructure

The product was received on Apr. 17, 2019 and testing was completed on Jun. 11, 2019. We, Sporton International (Kunshan) Inc., would like to declare that the tested sample has been evaluated in accordance with the test procedures and has been in compliance with the applicable technical standards.

The test results in this report apply exclusively to the tested model / sample. Without written approval of Sporton International (Kunshan) Inc., the test report shall not be reproduced except in full.

Jason Jia

Reviewed by: Jason Jia / Supervisor

James Huang

Approved by: James Huang / Manager



Sporton International (Kunshan) Inc.

**No. 1098, Pengxi North Road, Kunshan Economic Development Zone Jiangsu Province 215300
People's Republic of China**



TABLE OF CONTENTS

REVISION HISTORY..... 3
SUMMARY OF TEST RESULT 4
1 GENERAL DESCRIPTION 5
1.1 Applicant 5
1.2 Product Feature of Equipment Under Test..... 5
1.3 Product Specification of Equipment Under Test..... 6
1.4 Modification of EUT 7
1.5 Testing Location 7
1.6 Applicable Standards..... 7
2 TEST CONFIGURATION OF EQUIPMENT UNDER TEST 8
2.1 Carrier Frequency and Channel 8
2.2 Test Mode 9
2.3 Connection Diagram of Test System 11
2.4 Support Unit used in test configuration and system 11
2.5 EUT Operation Test Setup 12
2.6 Measurement Results Explanation Example..... 12
3 TEST RESULT 13
3.1 26dB & 99% Occupied Bandwidth Measurement 13
3.2 Maximum Conducted Output Power Measurement 15
3.3 Power Spectral Density Measurement 17
3.4 Unwanted Emissions Measurement 20
3.5 AC Conducted Emission Measurement..... 25
3.6 Automatically Discontinue Transmission 27
3.7 Antenna Requirements 28
4 LIST OF MEASURING EQUIPMENT 29
5 UNCERTAINTY OF EVALUATION 30
APPENDIX A. CONDUCTED TEST RESULTS
APPENDIX B. AC CONDUCTED EMISSION TEST RESULT
APPENDIX C. RADIATED SPURIOUS EMISSION
APPENDIX D. DUTY CYCLE PLOTS
APPENDIX E. SETUP PHOTOGRAPHS



REVISION HISTORY

REPORT NO.	VERSION	DESCRIPTION	ISSUED DATE
FR941708-01D	Rev. 01	Initial issue of report	Jun. 25, 2019



SUMMARY OF TEST RESULT

Report Section	FCC Rule	Description	Limit	Result	Remark
3.1	2.1049 & 15.403(i)	26dB & 99% Bandwidth	-	Pass	-
3.2	15.407(a)	Maximum Conducted Output Power	≤ 24 dBm	Pass	-
3.3	15.407(a)	Power Spectral Density	≤ 11 dBm	Pass	-
3.4	15.407(b)	Unwanted Emissions	15.407(b) & 15.209(a)	Pass	Under limit 7.39 dB at 5350.200 MHz
3.5	15.207	AC Conducted Emission	15.207(a)	Pass	Under limit 16.08 dB at 0.592 MHz
3.6	15.407(c)	Automatically Discontinue Transmission	Discontinue Transmission	Pass	-
3.7	15.203 & 15.407(a)	Antenna Requirement	N/A	Pass	-



1 General Description

1.1 Applicant

Xiaomi Communications Co., Ltd.

The Rainbow City of China Resources, NO.68, Qinghe Middle Street, Haidian District, Beijing, China

1.2 Product Feature of Equipment Under Test

Product Feature	
Equipment	Mobile Phone
Brand Name	XIAOMI
Model Name	M1906F9SH
FCC ID	2AFZZ-XMSF9SH
EUT supports Radios application	GSM/WCDMA/LTE WLAN 2.4GHz 802.11b/g/n HT20 WLAN 5GHz 802.11a/n HT20/HT40 WLAN 5GHz 802.11ac VHT20/VHT40/VHT80 Bluetooth BR / EDR / LE FM Receiver / GNSS
IMEI Code	Conducted: 864087040016356/864087040016301/864087040016364 Radiation: 864087040013197/864087040013205 Conduction: 864087040013338/864087040013346
HW Version	P2
SW Version	PKQ1.190416.001 V10
EUT Stage	Identical Prototype

Remark: The above EUT's information was declared by manufacturer. Please refer to the specifications or user's manual for more detailed description.



1.3 Product Specification of Equipment Under Test

Standards-related Product Specification	
Tx/Rx Frequency Range	5180 MHz ~ 5240 MHz 5260 MHz ~ 5320 MHz 5500 MHz ~ 5700 MHz
Maximum Output Power to Antenna	<p><5180 MHz ~ 5240 MHz> 802.11a : 15.12 dBm / 0.0325 W 802.11n HT20 : 13.92 dBm / 0.0247 W 802.11n HT40 : 13.32 dBm / 0.0215 W 802.11ac VHT20 : 14.01 dBm / 0.0252 W 802.11ac VHT40 : 14.14 dBm / 0.0259 W 802.11ac VHT80 : 12.03 dBm / 0.0160 W</p> <p><5260 MHz ~ 5320 MHz> 802.11a : 15.05 dBm / 0.0320 W 802.11n HT20 : 14.34 dBm / 0.0272 W 802.11n HT40 : 12.97 dBm / 0.0198 W 802.11ac VHT20 : 14.02 dBm / 0.0252 W 802.11ac VHT40 : 14.25 dBm / 0.0266 W 802.11ac VHT80 : 12.04 dBm / 0.0160 W</p> <p><5500 MHz ~ 5700 MHz > 802.11a : 14.40 dBm / 0.0275 W 802.11n HT20 : 13.92 dBm / 0.0247 W 802.11n HT40 : 12.99 dBm / 0.0199 W 802.11ac VHT20 : 13.57 dBm / 0.0228 W 802.11ac VHT40 : 13.88 dBm / 0.0244 W 802.11ac VHT80 : 11.58 dBm / 0.0144 W</p>
99% Occupied Bandwidth	<p><5180 MHz ~ 5240 MHz> 802.11a : 17.63 MHz 802.11ac VHT20 : 18.68 MHz 802.11ac VHT40 : 36.46 MHz 802.11ac VHT80 : 75.76 MHz</p> <p><5260 MHz ~ 5320 MHz> 802.11a : 17.68 MHz 802.11n HT20 : 18.68 MHz 802.11ac VHT40 : 36.36 MHz 802.11ac VHT80 : 75.64 MHz</p> <p><5500 MHz ~ 5700 MHz > 802.11a : 17.63 MHz 802.11n HT20 : 18.73 MHz 802.11ac VHT40 : 36.56 MHz 802.11ac VHT80 : 75.76 MHz</p>
Antenna Type / Gain	<p><5150 MHz ~ 5250 MHz> PIFA Antenna with gain -2.50 dBi</p> <p><5250 MHz ~ 5350 MHz> PIFA Antenna with gain -2.46 dBi</p> <p><5470 MHz ~ 5700 MHz> PIFA Antenna with gain -1.84 dBi</p>
Type of Modulation	802.11a/n : OFDM (BPSK / QPSK / 16QAM / 64QAM) 802.11ac : OFDM (BPSK / QPSK / 16QAM / 64QAM / 256QAM)



Note:

1. WLAN operation in 5600 MHz ~ 5650 MHz is notched.
2. For 802.11an HT20 / ac VHT20 and 802.11an HT40 / ac VHT40 mode, the whole testing have assessed only 802.11ac VHT20/ VHT40 for 5180 MHz ~ 5240 MHz and 802.11n HT20/ac VHT40 for 5260 MHz ~ 5320 MHz , 5500 MHz ~ 5720 MHz by referring to their maximum conducted power.

1.4 Modification of EUT

No modifications are made to the EUT during all test items.

1.5 Testing Location

Sporton International (Kunshan) Inc. is accredited to ISO/IEC 17025:2017 by American Association for Laboratory Accreditation with Certificate Number 5145.02.

Test Firm	Sporton International (Kunshan) Inc.		
Test Site Location	No. 1098, Pengxi North Road, Kunshan Economic Development Zone Jiangsu Province 215300 People's Republic of China TEL : +86-512-57900158 FAX : +86-512-57900958		
Test Site No.	Sporton Site No.	FCC Designation No.	FCC Test Firm Registration No.
	CO01-KS 03CH05-KS TH01-KS	CN1257	314309

1.6 Applicable Standards

According to the specifications of the manufacturer, the EUT must comply with the requirements of the following standards:

- ♦ 47 CFR Part 15 Subpart E
- ♦ FCC KDB 789033 D02 General UNII Test Procedures New Rules v02r01.
- ♦ ANSI C63.10-2013

Remark:

1. All test items were verified and recorded according to the standards and without any deviation during the test.
2. This EUT has also been tested and complied with the requirements of FCC Part 15, Subpart B, recorded in a separate test report.



2 Test Configuration of Equipment Under Test

- a. The EUT has been associated with peripherals and configuration operated in a manner tended to maximize its emission characteristics in a typical application. Frequency range investigated: conduction emission (150 kHz to 30 MHz), radiation emission (9 kHz to the 10th harmonic of the highest fundamental frequency or to 40 GHz, whichever is lower). For radiated measurement, pre-scanned in three orthogonal panels, X, Y, Z. The worst cases (X plane) were recorded in this report.
- b. AC power line Conducted Emission was tested under maximum output power.

2.1 Carrier Frequency and Channel

Frequency Band	Channel	Freq. (MHz)	Channel	Freq. (MHz)
5150-5250 MHz Band 1 (U-NII-1)	36	5180	44	5220
	38*	5190	46*	5230
	40	5200	48	5240
	42 [#]	5210		

Frequency Band	Channel	Freq. (MHz)	Channel	Freq. (MHz)
5250-5350 MHz Band 2 (U-NII-2A)	52	5260	60	5300
	54*	5270	62*	5310
	56	5280	64	5320
	58 [#]	5290		

Frequency Band	Channel	Freq. (MHz)	Channel	Freq. (MHz)
5470-5725 MHz Band 3 (U-NII-2C)	100	5500	112	5560
	102*	5510	116	5580
	104	5520	132	5660
	106 [#]	5530	134*	5670
	108	5540	136	5680
	110*	5550	140	5700

Note:

1. The above Frequency and Channel in "*" were 802.11n HT40 and 802.11ac VHT40.
2. The above Frequency and Channel in "[#]" were 802.11ac VHT80.



2.2 Test Mode

Final test modes are considering the modulation and worse data rates as below table.

Modulation	Data Rate
802.11a	6 Mbps
802.11n HT20	MCS0
802.11ac VHT20	MCS0
802.11ac VHT40	MCS0
802.11ac VHT80	MCS0

Test Cases	
AC Conducted Emission	Mode 1 : GSM 850 Idle + Bluetooth Link + WLAN Link (5G) + USB Cable (Charging from Adapter 1) + Earphone



Ch. #		Band I : 5150-5250 MHz	Band II : 5250-5350 MHz	Band III : 5470-5725MHz
		802.11a	802.11a	802.11a
L	Low	36	52	100
M	Middle	44	60	116
H	High	48	64	140

Ch. #		Band I : 5150-5250 MHz	Band II : 5250-5350 MHz	Band III : 5470-5725MHz
		802.11n HT20	802.11n HT20	802.11n HT20
L	Low	36	52	100
M	Middle	44	60	116
H	High	48	64	140

Ch. #		Band I : 5150-5250 MHz	Band II : 5250-5350 MHz	Band III : 5470-5725MHz
		802.11ac VHT20	802.11ac VHT20	802.11ac VHT20
L	Low	36	52	100
M	Middle	44	60	116
H	High	48	64	140

Ch. #		Band I : 5150-5250 MHz	Band II : 5250-5350 MHz	Band III : 5470-5725MHz
		802.11ac VHT40	802.11ac VHT40	802.11ac VHT40
L	Low	38	54	102
M	Middle	-	-	110
H	High	46	62	134

Ch. #		Band I : 5150-5250 MHz	Band II : 5250-5350 MHz	Band III : 5470-5725MHz
		802.11ac VHT80	802.11ac VHT80	802.11ac VHT80
L	Low	-	-	106
M	Middle	42	58	-
H	High	-	-	-

2.3 Connection Diagram of Test System

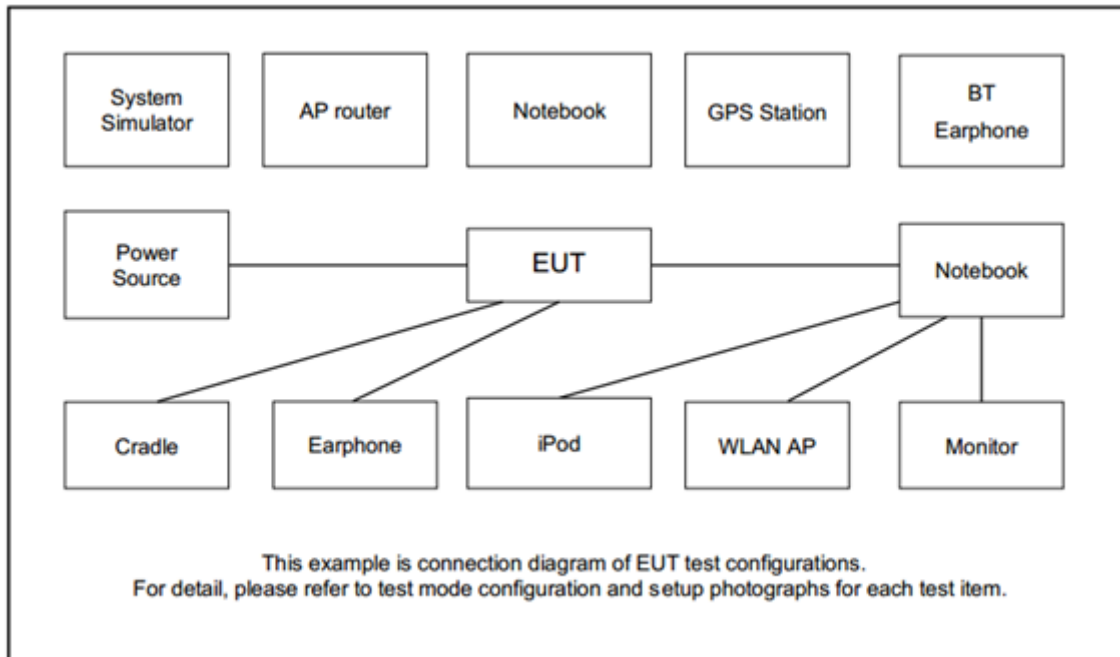

2.4 Support Unit used in test configuration and system

Item	Equipment	Trade Name	Model Name	FCC ID	Data Cable	Power Cord
1.	LTE Base Station	Anritsu	MT8820C	N/A	N/A	Unshielded,1.8m
2.	Bluetooth Earphone	Xiaomi	LYEJ02LM	N/A	N/A	N/A
3.	WLAN AP	D-Link	DIR-855	KA2DIR855A2	N/A	Unshielded,1.8m
4.	Notebook	Lenovo	G480	N/A	N/A	AC I/P: Unshielded, 1.8 m DC O/P: Shielded, 1.8 m
5.	Earphone	Lenovo	SH100	N/A	Unshielded, 1.2 m	N/A
6.	SD Card	Kingston	8GB	N/A	N/A	N/A



2.5 EUT Operation Test Setup

For WLAN RF test items, an engineering test program was provided and enabled to make EUT continuously transmit/receive.

For AC power line conducted emissions, the EUT was set to connect with the WLAN AP under large package sizes transmission.

2.6 Measurement Results Explanation Example

For all conducted test items:

The offset level is set in the spectrum analyzer to compensate the RF cable loss between EUT conducted output port and spectrum analyzer. With the offset compensation, the spectrum analyzer reading level is exactly the EUT RF output level.

Example :

The spectrum analyzer offset is derived from RF cable loss.

Offset = RF cable loss

Following shows an offset computation example with cable loss 6.6 dB

$$\begin{aligned} \text{Offset(dB)} &= \text{RF cable loss(dB)}. \\ &= 6.6 \text{ (dB)} \end{aligned}$$

3 Test Result

3.1 26dB & 99% Occupied Bandwidth Measurement

3.1.1 Description of 26dB & 99% Occupied Bandwidth

This section is for reporting purpose only.

There is no restriction limits for bandwidth.

3.1.2 Measuring Instruments

The measuring equipment is listed in the section 4 of this test report.

3.1.3 Test Procedures

1. The testing follows FCC KDB 789033 D02 General UNII Test Procedures New Rules v02r01. Section C) Emission bandwidth
2. Set RBW = approximately 1% of the emission bandwidth.
3. Set the VBW > RBW.
4. Detector = Peak.
5. Trace mode = max hold
6. Measure the maximum width of the emission that is 26 dB down from the peak of the emission. Compare this with the RBW setting of the analyzer. Readjust RBW and repeat measurement as needed until the RBW/EBW ratio is approximately 1%.
7. For 99% Bandwidth Measurement, the spectrum analyzer's resolution bandwidth (RBW) is set 1MHz and set the Video bandwidth (VBW) $\geq 3 * RBW$.
8. Measure and record the results in the test report.

3.1.4 Test Setup

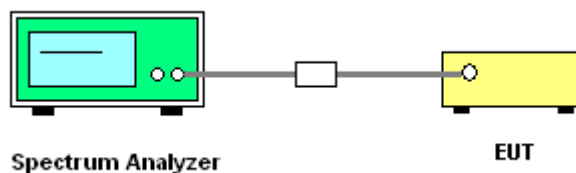

3.1.5 Test Result of 26dB & 99% Occupied Bandwidth

Please refer to Appendix A.

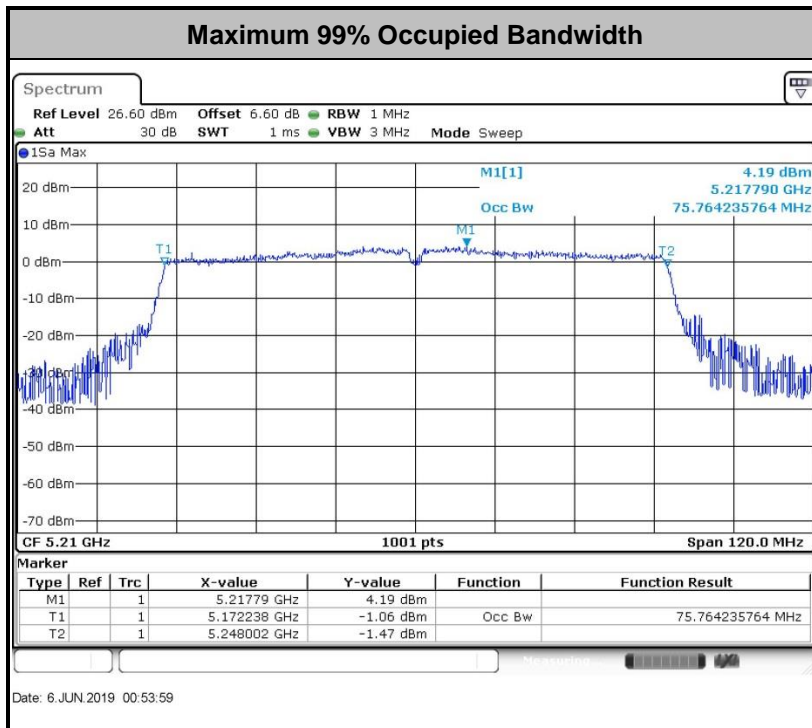
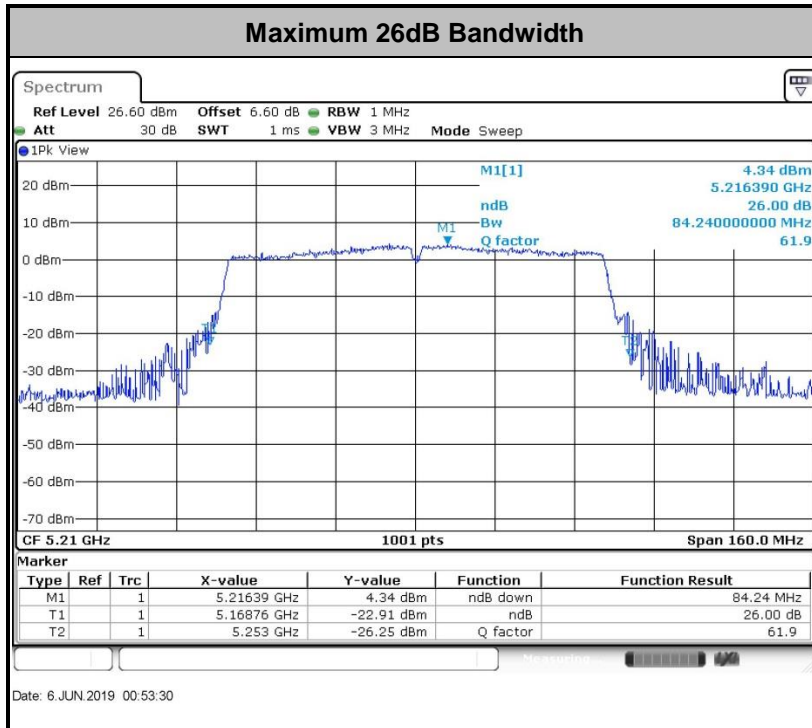

Note: The occupied channel bandwidth is maintained within the band of operation for all of the modulations.



3.2 Maximum Conducted Output Power Measurement

3.2.1 Limit of Maximum Conducted Output Power

<FCC 14-30 CFR 15.407>

For mobile and portable client devices in the 5.15–5.25 GHz band, the maximum conducted output power over the frequency band of operation shall not exceed 250 mW.

For the 5.25–5.725 GHz bands, the maximum conducted output power over the frequency bands of operation shall not exceed the lesser of 250 mW or $11 + 10 \log B$, dBm, where B is the 26 dB emission bandwidth in megahertz.

For the 5.47–5.6 GHz and 5.65–5.725 GHz band, the maximum conducted output power shall not exceed 250 mW or $11 + 10 \log_{10} B$, dBm, whichever power is less. The maximum e.i.r.p. shall not exceed 1.0 W or $17 + 10 \log_{10} B$, dBm, whichever is less. B is the 99% emission bandwidth in megahertz.

If transmitting antennas of directional gain greater than 6 dBi are used, the peak output power shall be reduced by the amount in dB that the directional gain of the antenna exceeds 6 dBi.

Note that U-NII-2 band, devices with a maximum e.i.r.p. greater than 500 mW shall implement TPC in order to have the capability to operate at least 6 dB below the maximum permitted e.i.r.p. of 1 W.

3.2.2 Measuring Instruments

The measuring equipment is listed in the section 4 of this test report.

3.2.3 Test Procedures

The testing follows Method PM of FCC KDB 789033 D02 General UNII Test Procedures New Rules v02r01.

Method PM (Measurement using an RF average power meter):

1. Measurement is performed using a wideband RF power meter.
2. The EUT is configured to transmit continuously with a consistent duty cycle at its maximum power control level.
3. Measure the average power of the transmitter, and the average power is corrected with duty factor, $10 \log(1/x)$, where x is the duty cycle.

3.2.4 Test Setup

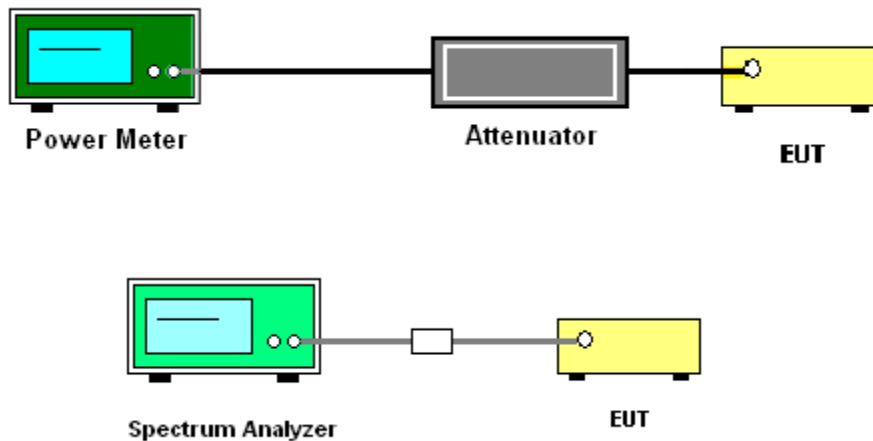

3.2.5 Test Result of Maximum Conducted Output Power

Please refer to Appendix A.



3.3 Power Spectral Density Measurement

3.3.1 Limit of Power Spectral Density

<FCC 14-30 CFR 15.407>

For mobile and portable client devices in the 5.15–5.25 GHz band, the maximum power spectral density shall not exceed 11dBm in any 1 megahertz band.

For the 5.25–5.725 GHz bands, the maximum power spectral density shall not exceed 11 dBm in any 1 megahertz band.

If transmitting antennas of directional gain greater than 6 dBi are used, the peak output power shall be reduced by the amount in dB that the directional gain of the antenna exceeds 6 dBi.

3.3.2 Measuring Instruments

The measuring equipment is listed in the section 4 of this test report.

3.3.3 Test Procedures

The testing follows FCC KDB 789033 D02 General UNII Test Procedures New Rules v02r01.
Section F) Maximum power spectral density.

Method SA-2

(trace averaging across on and off times of the EUT transmissions, followed by duty cycle correction).

- Measure the duty cycle.
 - Set span to encompass the entire emission bandwidth (EBW) of the signal.
 - Set RBW = 1 MHz.
 - Set VBW \geq 3 MHz.
 - Number of points in sweep \geq 2 Span / RBW.
 - Sweep time = auto.
 - Detector = RMS
 - Trace average at least 100 traces in power averaging mode.
 - Add $10 \log(1/x)$, where x is the duty cycle, to the measured power in order to compute the average power during the actual transmission times. For example, add $10 \log(1/0.25) = 6$ dB if the duty cycle is 25 percent.
1. The RF output of EUT was connected to the spectrum analyzer by a low loss cable.
 2. Each plot has already offset with cable loss, and attenuator loss. Measure the PPSD and record it.

3.3.4 Test Setup

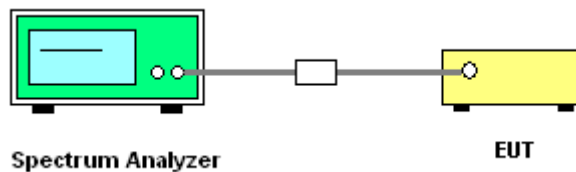

3.3.5 Test Result of Power Spectral Density

Please refer to Appendix A.

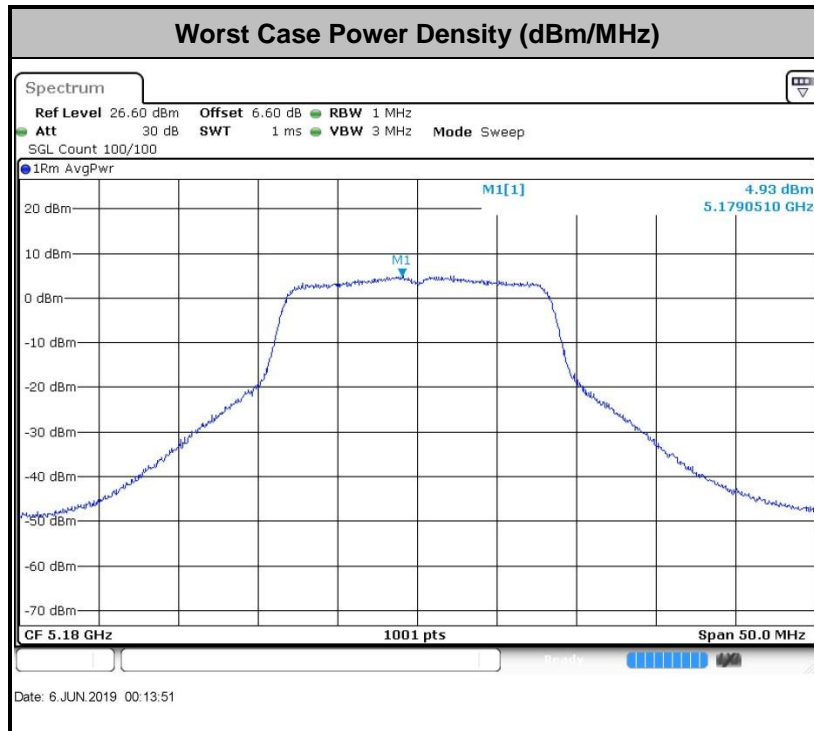

Note: Average Power Density (dB) = Measured value+ Duty Factor



3.4 Unwanted Emissions Measurement

This section is to measure unwanted emissions through radiated measurement for band edge spurious emissions and out of band emissions measurement.

3.4.1 Limit of Unwanted Emissions

- (1) For transmitters operating in the 5150-5250 MHz band: all emissions outside of the 5150-5350 MHz band shall not exceed an EIRP of -27dBm/MHz.

For transmitters operating in the 5250-5350 MHz band: all emissions outside of the 5150-5350 MHz band shall not exceed an EIRP of -27 dBm/MHz. Devices operating in the 5250-5350 MHz band that generate emissions in the 5150-5250 MHz band must meet all applicable technical requirements for operation in the 5150-5250 MHz band (including indoor use) or alternatively meet an out-of-band emission EIRP limit of -27 dBm/MHz in the 5150-5250 MHz band.

For transmitters operating in the 5470-5600 MHz and 5650-5725MHz band: all emissions outside of the 5470-5600 MHz and 5650-5725MHz band shall not exceed an EIRP of -27 dBm/MHz.

- (2) Unwanted spurious emissions fallen in restricted bands shall comply with the general field strength limits as below table,

Frequency (MHz)	Field Strength (microvolts/meter)	Measurement Distance (meters)
0.009 – 0.490	2400/F(kHz)	300
0.490 – 1.705	24000/F(kHz)	30
1.705 – 30.0	30	30
30 – 88	100	3
88 – 216	150	3
216 - 960	200	3
Above 960	500	3



EIRP (dBm)	Field Strength at 3m (dBµV/m)
- 27	68.2

Note: The following formula is used to convert the EIRP to field strength.

$$EIRP = E_{Meas} + 20\log (d_{Meas}) - 104.7$$

where

EIRP is the equivalent isotropically radiated power, in dBm

E_{Meas} is the field strength of the emission at the measurement distance, in dBµV/m

d_{Meas} is the measurement distance, in m

3.4.2 Measuring Instruments

The measuring equipment is listed in the section 4 of this test report.



3.4.3 Test Procedures

1. The testing follows FCC KDB 789033 D02 General UNII Test Procedures New Rules v02r01. Section G) Unwanted emissions measurement.
 - (1) Procedure for Unwanted Emissions Measurements Below 1000MHz
 - RBW = 120 kHz
 - VBW = 300 kHz
 - Detector = Peak
 - Trace mode = max hold
 - (2) Procedure for Peak Unwanted Emissions Measurements Above 1000 MHz
 - RBW = 1 MHz
 - VBW \geq 3 MHz
 - Detector = Peak
 - Sweep time = auto
 - Trace mode = max hold
 - (3) Procedures for Average Unwanted Emissions Measurements Above 1000MHz
 - RBW = 1 MHz
 - VBW = 10 Hz, when duty cycle is no less than 98 percent.
 - VBW \geq 1/T, when duty cycle is less than 98 percent where T is the minimum transmission duration over which the transmitter is on and is transmitting at its maximum power control level for the tested mode of operation.
2. The EUT was placed on a turntable with 0.8 meter for frequency below 1GHz and 1.5 meter for frequency above 1GHz respectively above ground.
3. The EUT was set 3 meters from the interference receiving antenna which was mounted on the top of a variable height antenna tower.
4. The antenna is a broadband antenna and its height is adjusted between one meter and four meters above ground to find the maximum value of the field strength for both horizontal polarization and vertical polarization of the antenna.
5. For each suspected emission, the EUT was arranged to its worst case and then adjust the antenna tower (from 1 m to 4 m) and turntable (from 0 degree to 360 degrees) to find the maximum reading.
6. For testing below 1GHz, if the emission level of the EUT in peak mode was 3 dB lower than the limit specified, then peak values of EUT will be reported, otherwise, the emissions will be repeated one by one using the CISPR quasi-peak method and reported.
7. For testing above 1GHz, the emission level of the EUT in peak mode was 20dB lower than average limit (that means the emission level in average mode also complies with the limit in average mode), then peak values of EUT will be reported, otherwise, the emissions will be measured in average mode again and reported.

3.4.4 Test Setup

For radiated emissions below 30MHz

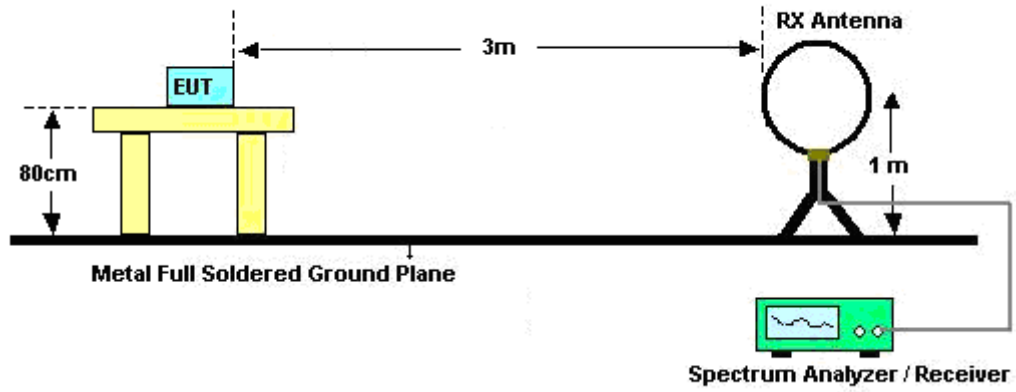

For radiated emissions from 30MHz to 1GHz

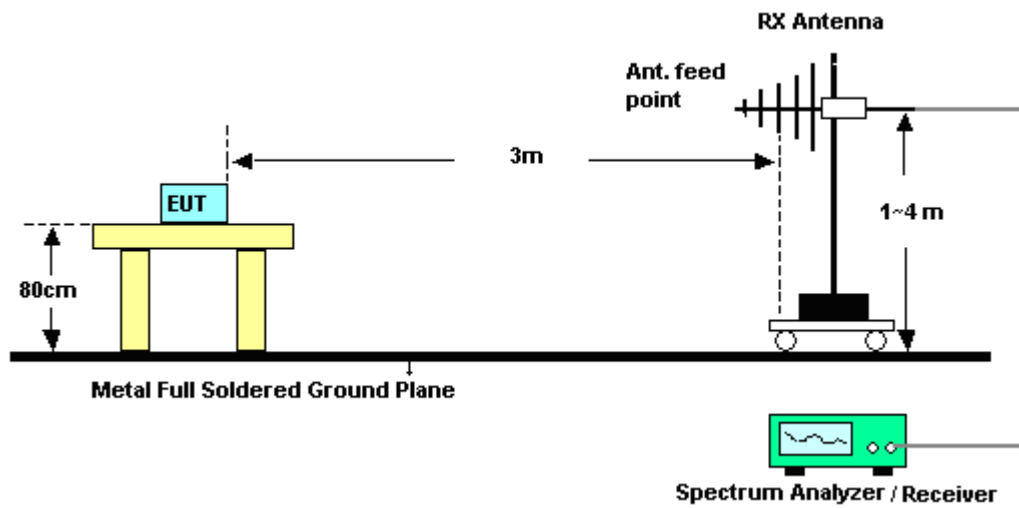

For radiated emissions above 1GHz

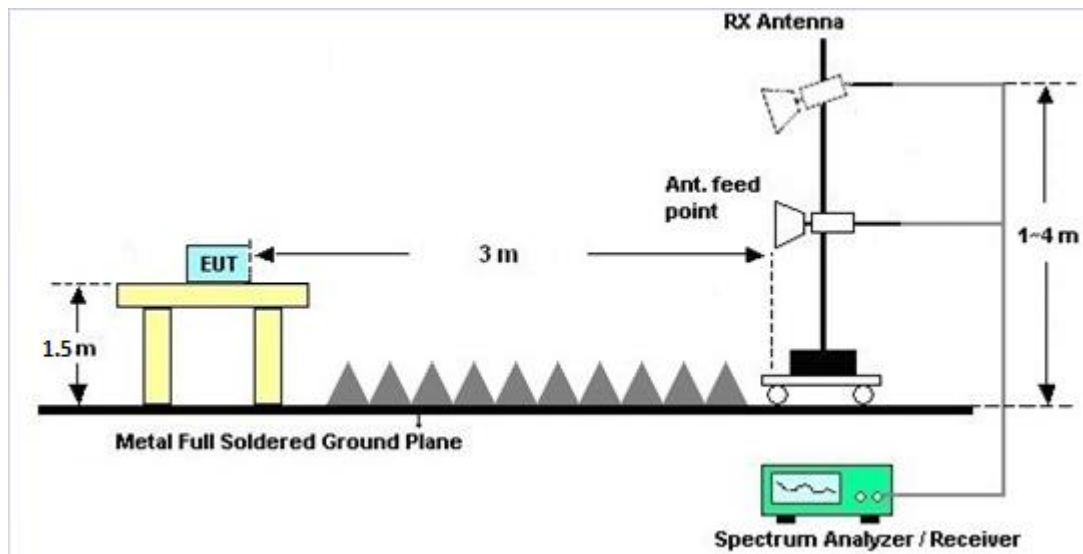

3.4.5 Test Results of Radiated Spurious Emissions (9 kHz ~ 30 MHz)

The low frequency, which started from 9 kHz to 30MHz, was pre-scanned and the result which was 20dB lower than the limit line was not reported.

There is a comparison data of both open-field test site and semi-Anechoic chamber, and the result came out very similar.

3.4.6 Test Result of Radiated Spurious at Band Edges

Please refer to Appendix C.

3.4.7 Duty Cycle

Please refer to Appendix D.

3.4.8 Test Result of Radiated Spurious Emissions (30MHz ~ 10th Harmonic)

Please refer to Appendix C.



3.5 AC Conducted Emission Measurement

3.5.1 Limit of AC Conducted Emission

For equipment that is designed to be connected to the public utility (AC) power line, the radio frequency voltage that is conducted back onto the AC power line on any frequency or frequencies within the band 150 kHz to 30 MHz shall not exceed the limits in the following table.

Frequency of emission (MHz)	Conducted limit (dBµV)	
	Quasi-peak	Average
0.15-0.5	66 to 56*	56 to 46*
0.5-5	56	46
5-30	60	50

*Decreases with the logarithm of the frequency.

3.5.2 Measuring Instruments

The measuring equipment is listed in the section 4 of this test report.

3.5.3 Test Procedures

1. The EUT was placed 0.4 meter from the conducting wall of the shielding room was kept at least 80 centimeters from any other grounded conducting surface.
2. Connect EUT to the power mains through a line impedance stabilization network (LISN).
3. All the support units are connecting to the other LISN.
4. The LISN provides 50 ohm coupling impedance for the measuring instrument.
5. The FCC states that a 50 ohm, 50 microhenry LISN should be used.
6. Both sides of AC line were checked for maximum conducted interference.
7. The frequency range from 150 kHz to 30 MHz was searched.
8. Set the test-receiver system to Peak Detect Function and specified bandwidth with Maximum Hold Mode.

3.5.4 Test Setup



3.5.5 Test Result of AC Conducted Emission

Please refer to Appendix B.



3.6 Automatically Discontinue Transmission

3.6.1 Limit of Automatically Discontinue Transmission

The device shall automatically discontinue transmission in case of either absence of information to transmit or operational failure. These provisions are not intended to preclude the transmission of control or signaling information or the use of repetitive codes used by certain digital technologies to complete frame or burst intervals. Applicants shall include in their application for equipment authorization to describe how this requirement is met.

3.6.2 Measuring Instruments

The measuring equipment is listed in the section 4 of this test report.

3.6.3 Test Result of Automatically Discontinue Transmission

While the EUT is not transmitting any information, the EUT can automatically discontinue transmission and become standby mode for power saving. The EUT can detect the controlling signal of ACK message transmitting from remote device and verify whether it shall resend or discontinue transmission.



3.7 Antenna Requirements

3.7.1 Standard Applicable

If transmitting antenna directional gain is greater than 6 dBi, both the peak transmit power and the peak power spectral density shall be reduced by the amount in dB that the directional gain of the antenna exceeds 6 dBi.

3.7.2 Antenna Anti-Replacement Construction

An embedded-in antenna design is used.

3.7.3 Antenna Gain

The antenna peak gain of EUT is less than 6 dBi. Therefore, it is not necessary to reduce maximum peak output power limit.



4 List of Measuring Equipment

Instrument	Manufacturer	Model No.	Serial No.	Characteristics	Calibration Date	Test Date	Due Date	Remark
Spectrum Analyzer	R&S	FSV40	101040	10Hz~40GHz	Aug. 07, 2018	Jun. 06, 2019~ Jun. 11, 2019	Aug. 06, 2019	Conducted (TH01-KS)
Pulse Power Sensor	Anritsu	MA2411B	0917070	300MHz~40GHz	Jan. 14, 2019	Jun. 06, 2019~ Jun. 11, 2019	Jan. 13, 2020	Conducted (TH01-KS)
Power Meter	Anritsu	ML2495A	1005002	50MHz Bandwidth	Jan. 14, 2019	Jun. 06, 2019~ Jun. 11, 2019	Jan. 13, 2020	Conducted (TH01-KS)
EMI Test Receiver	Keysight	N9038A	MY57290151	3Hz~8.5GHz;Max 30dBm	Jun. 25, 2018	Jun. 10, 2019	Jun. 24, 2019	Radiation (03CH05-KS)
EXA Spectrum Analyzer	Keysight	N9010A	MY55370528	10Hz~44GHz	Oct. 09, 2018	Jun. 10, 2019	Oct. 08, 2019	Radiation (03CH05-KS)
Loop Antenna	R&S	HFH2-Z2	100321	9kHz~30MHz	Oct. 19, 2018	Jun. 10, 2019	Oct. 18, 2019	Radiation (03CH05-KS)
Bilog Antenna	TeseQ	CBL6111D	49922	30MHz~1GHz	Jun. 12, 2018	Jun. 10, 2019	Jun. 11, 2019	Radiation (03CH05-KS)
Double Ridge Horn Antenna	ETS-Lindgren	3117	75959	1GHz~18GHz	Jan. 27, 2019	Jun. 10, 2019	Jan. 26, 2020	Radiation (03CH05-KS)
SHF-EHF Horn	Com-power	AH-840	101070	18GHz~40GHz	Jan. 05, 2019	Jun. 10, 2019	Jan. 04, 2020	Radiation (03CH05-KS)
Amplifier	SONOMA	310N	187289	9KHz~1GHz	Aug. 06, 2018	Jun. 10, 2019	Aug. 05, 2019	Radiation (03CH05-KS)
Amplifier	MITEQ	TTA1840-35-HG	2014749	18~40GHz	Jan. 14, 2019	Jun. 10, 2019	Jan. 13, 2020	Radiation (03CH05-KS)
high gain Amplifier	MITEQ	AMF-7D-0010 1800-30-10P	2025788	1Ghz~18Ghz	Aug. 17, 2018	Jun. 10, 2019	Aug. 16, 2019	Radiation (03CH05-KS)
Amplifier	Keysight	83017A	MY53270316	500MHz~26.5GHz	Dec. 22, 2018	Jun. 10, 2019	Dec. 21, 2019	Radiation (03CH05-KS)
AC Power Source	Chroma	61601	F104090004	N/A	NCR	Jun. 10, 2019	NCR	Radiation (03CH05-KS)
Turn Table	ChamPro	EM 1000-T	060762-T	0~360 degree	NCR	Jun. 10, 2019	NCR	Radiation (03CH05-KS)
Antenna Mast	ChamPro	EM 1000-A	060762-A	1 m~4 m	NCR	Jun. 10, 2019	NCR	Radiation (03CH05-KS)
EMI Receiver	R&S	ESC17	100768	9kHz~7GHz;	Apr. 19, 2018	May 29, 2019	Apr. 18, 2019	Conduction (CO01-KS)
AC LISN	MessTec	AN3016	060103	9kHz~30MHz	Oct. 12, 2018	May 29, 2019	Oct. 11, 2019	Conduction (CO01-KS)
AC LISN (for auxiliary equipment)	MessTec	AN3016	060105	9kHz~30MHz	Nov. 19, 2018	May 29, 2019	Nov. 18, 2019	Conduction (CO01-KS)
AC Power Source	Chroma	61602	ABP00000811	AC 0V~300V, 45Hz~1000Hz	Oct. 12, 2018	May 29, 2019	Oct. 11, 2019	Conduction (CO01-KS)



5 Uncertainty of Evaluation

The measurement uncertainties shown below were calculated in accordance with the requirements of ANSI 63.10-2013. All the measurement uncertainty value were shown with a coverage K=2 to indicate 95% level of confidence. The measurement data show herein meets or exceeds the CISPR measurement uncertainty values specified in CISPR 16-4-2 and can be compared directly to specified limit to determine compliance.

Uncertainty of Conducted Emission Measurement (150kHz ~ 30MHz)

Measuring Uncertainty for a Level of Confidence of 95% (U = 2Uc(y))	2.9dB
---	-------

Uncertainty of Radiated Emission Measurement (30 MHz ~ 1000 MHz)

Measuring Uncertainty for a Level of Confidence of 95% (U = 2Uc(y))	5.0 dB
---	--------

Uncertainty of Radiated Emission Measurement (1000 MHz ~ 18000 MHz)

Measuring Uncertainty for a Level of Confidence of 95% (U = 2Uc(y))	5.0 dB
---	--------

Uncertainty of Radiated Emission Measurement (18000 MHz ~ 40000 MHz)

Measuring Uncertainty for a Level of Confidence of 95% (U = 2Uc(y))	5.0 dB
---	--------



Appendix A. Conducted Test Results

Test Engineer:	Lion Ran	Temperature:	21~25	°C
Test Date:	2019/06/06~2019/06/11	Relative Humidity:	51~54	%

TEST RESULTS DATA
26dB and 99% OBW

Band I										
Mod.	Data Rate	Ntx	CH.	Freq. (MHz)	99% Bandwidth (MHz)	26 dB Bandwidth (MHz)	IC 99% Bandwidth Power Limit (dBm)	IC 99% Bandwidth EIRP Limit (dBm)		
11a	6Mbps	1	36	5180	17.63	23.38	-	22.46		
11a	6Mbps	1	44	5220	17.58	23.48	-	22.45		
11a	6Mbps	1	48	5240	17.63	23.63	-	22.46		
VHT20	MCS0	1	36	5180	18.68	23.83	-	22.71		
VHT20	MCS0	1	44	5220	18.68	24.63	-	22.71		
VHT20	MCS0	1	48	5240	18.63	24.53	-	22.70		
VHT40	MCS0	1	38	5190	36.46	41.54	-	23.01		
VHT40	MCS0	1	46	5230	36.46	41.72	-	23.01		
VHT80	MCS0	1	42	5210	75.76	84.24	-	23.01		

TEST RESULTS DATA
Power Spectral Density

FCC Band I										
Mod.	Data Rate	NTX	CH.	Freq. (MHz)	Duty Factor (dB)	Average Power Density (dBm/MHz)	Average PSD Limit (dBm/MHz)	DG (dBi)	-	Pass/Fail
11a	6Mbps	1	36	5180	0.09	5.02	11.00	-2.50		Pass
11a	6Mbps	1	44	5220	0.09	4.98	11.00	-2.50		Pass
11a	6Mbps	1	48	5240	0.09	4.58	11.00	-2.50		Pass
VHT20	MCS0	1	36	5180	0.07	3.79	11.00	-2.50		Pass
VHT20	MCS0	1	44	5220	0.07	3.75	11.00	-2.50		Pass
VHT20	MCS0	1	48	5240	0.07	3.25	11.00	-2.50		Pass
VHT40	MCS0	1	38	5190	0.16	0.97	11.00	-2.50		Pass
VHT40	MCS0	1	46	5230	0.16	0.56	11.00	-2.50		Pass
VHT80	MCS0	1	42	5210	0.30	-4.00	11.00	-2.50		Pass

TEST RESULTS DATA
Average Power Table

FCC Band I										
Mod.	Data Rate	Ntx	CH.	Freq. (MHz)	Duty Factor (dB)	Average Conducted Power (dBm)	FCC Conducted Power Limit (dBm)	DG (dBi)		Pass/Fail
11a	6Mbps	1	36	5180	0.09	14.74	24.00	-2.50		Pass
11a	6Mbps	1	44	5220	0.09	15.12	24.00	-2.50		Pass
11a	6Mbps	1	48	5240	0.09	15.02	24.00	-2.50		Pass
HT20	MCS0	1	36	5180	0.07	13.58	24.00	-2.50		Pass
HT20	MCS0	1	44	5220	0.07	13.92	24.00	-2.50		Pass
HT20	MCS0	1	48	5240	0.07	13.88	24.00	-2.50		Pass
HT40	MCS0	1	38	5190	0.16	13.17	24.00	-2.50		Pass
HT40	MCS0	1	46	5230	0.16	13.32	24.00	-2.50		Pass
VHT20	MCS0	1	36	5180	0.08	13.66	24.00	-2.50		Pass
VHT20	MCS0	1	44	5220	0.08	14.01	24.00	-2.50		Pass
VHT20	MCS0	1	48	5240	0.08	13.89	24.00	-2.50		Pass
VHT40	MCS0	1	38	5190	0.16	13.91	24.00	-2.50		Pass
VHT40	MCS0	1	46	5230	0.16	14.14	24.00	-2.50		Pass
VHT80	MCS0	1	42	5210	0.30	12.03	24.00	-2.50		Pass

TEST RESULTS DATA
26dB and 99% OBW

Band II										
Mod.	Data Rate	NTX	CH.	Freq. (MHz)	99% Bandwidth (MHz)	26 dB Bandwidth (MHz)	IC 99% Bandwidth Power Limit (dBm)	IC 99% Bandwidth EIRP Limit (dBm)	FCC 26dB Bandwidth Power Limit (dBm)	Note
11a	6M bps	1	52	5260	17.68	24.03	23.48	29.48	23.98	
11a	6M bps	1	60	5300	17.68	23.88	23.48	29.48	23.98	
11a	6M bps	1	64	5320	17.63	23.53	23.46	29.46	23.98	
HT20	MCS 0	1	52	5260	18.68	24.53	23.71	29.71	23.98	
HT20	MCS 0	1	60	5300	18.63	24.58	23.70	29.70	23.98	
HT20	MCS 0	1	64	5320	18.63	24.83	23.70	29.70	23.98	
VHT40	MCS 0	1	54	5270	36.36	41.81	23.98	30.00	23.98	
VHT40	MCS 0	1	62	5310	36.36	41.72	23.98	30.00	23.98	
VHT80	MCS 0	1	58	5290	75.64	83.60	23.98	30.00	23.98	

TEST RESULTS DATA
Power Spectral Density

Band II										
Mod.	Data Rate	NTX	CH.	Freq. (MHz)	Duty Factor (dB)	Average Power Density (dBm/MHz)	Average PSD Limit (dBm/MHz)	DG (dBi)		Pass/Fail
11a	6M bps	1	52	5260	0.09	3.87	11.00	-2.46		Pass
11a	6M bps	1	60	5300	0.09	4.44	11.00	-2.46		Pass
11a	6M bps	1	64	5320	0.09	4.14	11.00	-2.46		Pass
HT20	MCS 0	1	52	5260	0.07	3.16	11.00	-2.46		Pass
HT20	MCS 0	1	60	5300	0.07	3.50	11.00	-2.46		Pass
HT20	MCS 0	1	64	5320	0.07	3.39	11.00	-2.46		Pass
VHT40	MCS 0	1	54	5270	0.16	0.35	11.00	-2.46		Pass
VHT40	MCS 0	1	62	5310	0.16	0.36	11.00	-2.46		Pass
VHT80	MCS 0	1	58	5290	0.30	-4.53	11.00	-2.46		Pass

TEST RESULTS DATA
Average Power Table

FCC Band II										
Mod.	Data Rate	NTX	CH.	Freq. (MHz)	Duty Factor (dB)	Average Conducted Power (dBm)	FCC Conducted Power Limit (dBm)	DG (dBi)	EIRP Power Limit (dBm)	Pass/Fail
11a	6M bps	1	52	5260	0.09	14.57	23.98	-2.46	26.99	Pass
11a	6M bps	1	60	5300	0.09	14.87	23.98	-2.46	26.99	Pass
11a	6M bps	1	64	5320	0.09	15.05	23.98	-2.46	26.99	Pass
HT20	MCS 0	1	52	5260	0.07	13.99	23.98	-2.46	26.99	Pass
HT20	MCS 0	1	60	5300	0.07	14.20	23.98	-2.46	26.99	Pass
HT20	MCS 0	1	64	5320	0.07	14.34	23.98	-2.46	26.99	Pass
HT40	MCS 0	1	54	5270	0.16	12.91	23.98	-2.46	26.99	Pass
HT40	MCS 0	1	62	5310	0.16	12.97	23.98	-2.46	26.99	Pass
VHT20	MCS 0	1	52	5260	0.08	13.78	23.98	-2.46	26.99	Pass
VHT20	MCS 0	1	60	5300	0.08	13.89	23.98	-2.46	26.99	Pass
VHT20	MCS 0	1	64	5320	0.08	14.02	23.98	-2.46	26.99	Pass
VHT40	MCS 0	1	54	5270	0.16	14.16	23.98	-2.46	26.99	Pass
VHT40	MCS 0	1	62	5310	0.16	14.25	23.98	-2.46	26.99	Pass
VHT80	MCS 0	1	58	5290	0.30	12.04	23.98	-2.46	26.99	Pass

TEST RESULTS DATA
26dB and 99% OBW

Band III										
Mod.	Data Rate	NTX	CH.	Freq. (MHz)	99% Bandwidth (MHz)	26 dB Bandwidth (MHz)	IC 99% Bandwidth Power Limit (dBm)	IC 99% Bandwidth EIRP Limit (dBm)	FCC 26dB Bandwidth Power Limit (dBm)	Note
11a	6M bps	1	100	5500	17.63	24.23	23.46	29.46	23.98	
11a	6M bps	1	116	5580	17.63	23.53	23.46	29.46	23.98	
11a	6M bps	1	140	5700	17.58	23.33	23.45	29.45	23.98	
HT20	MCS 0	1	100	5500	18.73	24.08	23.73	29.73	23.98	
HT20	MCS 0	1	116	5580	18.58	24.23	23.69	29.69	23.98	
HT20	MCS 0	1	140	5700	18.73	24.23	23.73	29.73	23.98	
VHT40	MCS 0	1	102	5510	36.46	41.99	23.98	30.00	23.98	
VHT40	MCS 0	1	110	5550	36.56	41.72	23.98	30.00	23.98	
VHT40	MCS 0	1	134	5670	36.36	41.99	23.98	30.00	23.98	
VHT80	MCS 0	1	106	5530	75.76	83.76	23.98	30.00	23.98	

TEST RESULTS DATA
Power Spectral Density

Band III										
Mod.	Data Rate	NTX	CH.	Freq. (MHz)	Duty Factor (dB)	Average Power Density (dBm/MHz)	Average PSD Limit (dBm/MHz)	DG (dBi)		Pass/Fail
11a	6M bps	1	100	5500	0.09	3.87	11.00	-1.84		Pass
11a	6M bps	1	116	5580	0.09	4.19	11.00	-1.84		Pass
11a	6M bps	1	140	5700	0.09	3.80	11.00	-1.84		Pass
HT20	MCS 0	1	100	5500	0.07	3.29	11.00	-1.84		Pass
HT20	MCS 0	1	116	5580	0.07	3.44	11.00	-1.84		Pass
HT20	MCS 0	1	140	5700	0.07	3.11	11.00	-1.84		Pass
VHT40	MCS 0	1	102	5510	0.16	-0.14	11.00	-1.84		Pass
VHT40	MCS 0	1	110	5550	0.16	-0.24	11.00	-1.84		Pass
VHT40	MCS 0	1	134	5670	0.16	-0.24	11.00	-1.84		Pass
VHT80	MCS 0	1	106	5530	0.30	-4.57	11.00	-1.84		Pass

TEST RESULTS DATA
Average Power Table

FCC Band III										
Mod.	Data Rate	NTX	CH.	Freq. (MHz)	Duty Factor (dB)	Average Conducted Power (dBm)	FCC Conducted Power Limit (dBm)	DG (dBi)	EIRP Power Limit (dBm)	Pass/Fail
11a	6M bps	1	100	5500	0.09	13.70	23.98	-1.84	26.99	Pass
11a	6M bps	1	116	5580	0.09	14.13	23.98	-1.84	26.99	Pass
11a	6M bps	1	140	5700	0.09	14.40	23.98	-1.84	26.99	Pass
HT20	MCS 0	1	100	5500	0.07	13.44	23.98	-1.84	26.99	Pass
HT20	MCS 0	1	116	5580	0.07	13.84	23.98	-1.84	26.99	Pass
HT20	MCS 0	1	140	5700	0.07	13.92	23.98	-1.84	26.99	Pass
HT40	MCS 0	1	102	5510	0.16	11.99	23.98	-1.84	26.99	Pass
HT40	MCS 0	1	110	5550	0.16	12.24	23.98	-1.84	26.99	Pass
HT40	MCS 0	1	134	5670	0.16	12.99	23.98	-1.84	26.99	Pass
VHT20	MCS 0	1	100	5500	0.08	13.00	23.98	-1.84	26.99	Pass
VHT20	MCS 0	1	116	5580	0.08	13.37	23.98	-1.84	26.99	Pass
VHT20	MCS 0	1	140	5700	0.08	13.57	23.98	-1.84	26.99	Pass
VHT40	MCS 0	1	102	5510	0.16	12.99	23.98	-1.84	26.99	Pass
VHT40	MCS 0	1	110	5550	0.16	13.01	23.98	-1.84	26.99	Pass
VHT40	MCS 0	1	134	5670	0.16	13.88	23.98	-1.84	26.99	Pass
VHT80	MCS 0	1	106	5530	0.30	11.58	23.98	-1.84	26.99	Pass



Appendix B. AC Conducted Emission Test Results

Test Engineer :	Amos Zhang	Temperature :	25.3~26.2°C
		Relative Humidity :	28~30%
Test Voltage :	120Vac / 60Hz	Phase :	Line
Remark :	All emissions not reported here are more than 10 dB below the prescribed limit.		

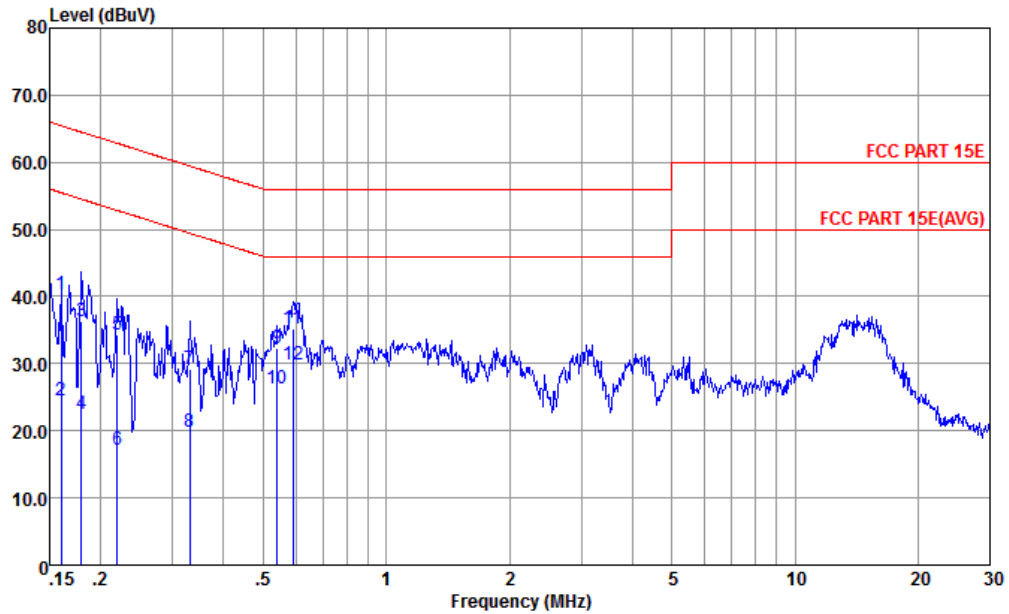

Site : CO01-KS
Condition : FCC PART 15E LISN-L-181119-060105 LINE

: 864087040013338/864087040013346 #15

	Freq	Level	Over Limit	Limit Line	Read Level	LISN Factor	Cable Loss	Remark
	MHz	dBuV	dB	dBuV	dBuV	dB	dB	
1	0.160	40.35	-25.12	65.47	29.80	0.10	10.45	QP
2	0.160	24.45	-31.02	55.47	13.90	0.10	10.45	Average
3	0.180	36.42	-28.08	64.50	25.90	0.11	10.41	QP
4	0.180	22.42	-32.08	54.50	11.90	0.11	10.41	Average
5	0.220	34.38	-28.45	62.83	23.90	0.13	10.35	QP
6	0.220	17.18	-35.65	52.83	6.70	0.13	10.35	Average
7	0.330	29.24	-30.20	59.44	18.80	0.15	10.29	QP
8	0.330	19.94	-29.50	49.44	9.50	0.15	10.29	Average
9	0.541	32.31	-23.69	56.00	21.90	0.17	10.24	QP
10	0.541	26.21	-19.79	46.00	15.80	0.17	10.24	Average
11	0.592	35.22	-20.78	56.00	24.80	0.18	10.24	QP
12 *	0.592	29.92	-16.08	46.00	19.50	0.18	10.24	Average



Test Engineer :	Amos Zhang	Temperature :	25.3~26.2°C
		Relative Humidity :	28~30%
Test Voltage :	120Vac / 60Hz	Phase :	Neutral
Remark :	All emissions not reported here are more than 10 dB below the prescribed limit.		

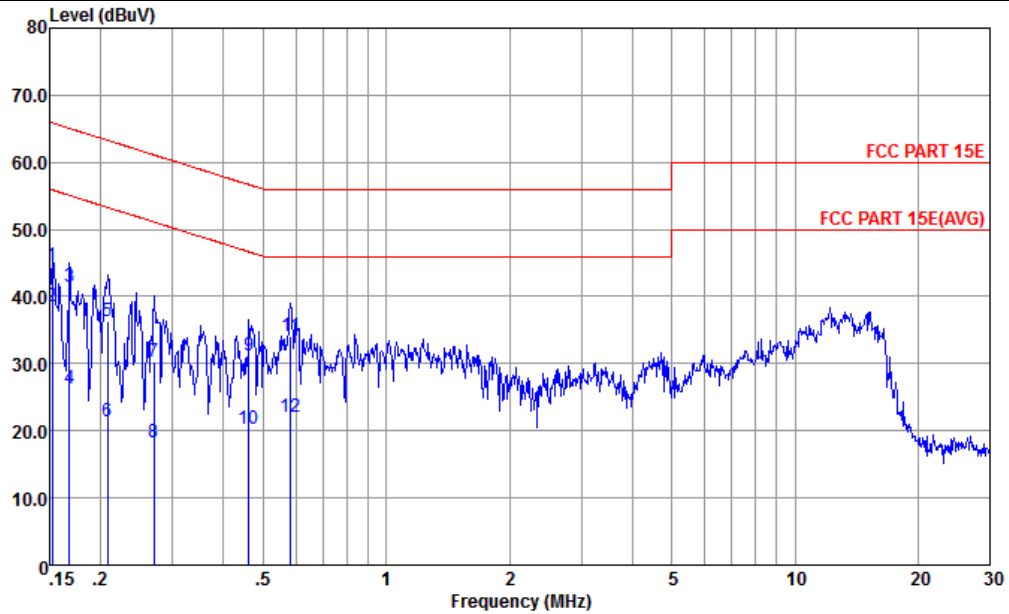

Site : CO01-KS
 Condition : FCC PART 15E LISN-N-181119-060105 NEUTRAL

:864087040013338/864087040013346 #15

	Freq	Level	Over Limit	Limit Line	Read Level	LISN Factor	Cable Loss	Remark
	MHz	dBuV	dB	dBuV	dBuV	dB	dB	
1	0.152	44.55	-21.32	65.87	33.90	0.18	10.47	QP
2 *	0.152	38.45	-17.42	55.87	27.80	0.18	10.47	Average
3	0.168	41.51	-23.57	65.08	30.90	0.18	10.43	QP
4	0.168	26.31	-28.77	55.08	15.70	0.18	10.43	Average
5	0.208	36.43	-26.84	63.27	25.90	0.17	10.36	QP
6	0.208	21.33	-31.94	53.27	10.80	0.17	10.36	Average
7	0.270	30.39	-30.73	61.12	19.91	0.16	10.32	QP
8	0.270	18.29	-32.83	51.12	7.81	0.16	10.32	Average
9	0.461	31.20	-25.47	56.67	20.80	0.15	10.25	QP
10	0.461	20.20	-26.47	46.67	9.80	0.15	10.25	Average
11	0.582	34.18	-21.82	56.00	23.80	0.14	10.24	QP
12	0.582	22.08	-23.92	46.00	11.70	0.14	10.24	Average



Appendix C. Radiated Spurious Emission

Band 1 - 5150~5250MHz

WIFI 802.11a (Band Edge @ 3m)

WIFI Ant.	Note	Frequency	Level	Over Limit	Limit Line	Read Level	Antenna Factor	Cable Loss	Preamp Factor	Ant Pos	Table Pos	Peak Avg.	Pol.
1		(MHz)	(dBμV/m)	(dB)	(dBμV/m)	(dBμV)	(dB/m)	(dB)	(dB)	(cm)	(deg)	(P/A)	(H/V)
802.11a CH 36 5180MHz		5137.92	55.25	-18.75	74	48.55	35.06	8.14	36.5	106	110	P	H
		5148.16	42.54	-11.46	54	35.84	35.06	8.14	36.5	106	110	A	H
	*	5178	103.6	-	-	96.84	35.08	8.17	36.49	106	110	P	H
		5178	95.81	-	-	89.05	35.08	8.17	36.49	106	110	A	H
		5140.48	51.45	-22.55	74	44.75	35.06	8.14	36.5	100	89	P	V
		5149.92	41.75	-12.25	54	35.05	35.06	8.14	36.5	100	89	A	V
	*	5178	100.38	-	-	93.62	35.08	8.17	36.49	100	89	P	V
		5178	92.55	-	-	85.79	35.08	8.17	36.49	100	89	A	V
Remark	1. No other spurious found. 2. All results are PASS against Peak and Average limit line.												



Band 1 5150~5250MHz

WIFI 802.11a (Harmonic @ 3m)

WIFI Ant. 1	Note	Frequency (MHz)	Level (dBμV/m)	Over Limit (dB)	Limit Line (dBμV/m)	Read Level (dBμV)	Antenna Factor (dB/m)	Cable Loss (dB)	Preamp Factor (dB)	Ant Pos (cm)	Table Pos (deg)	Peak Avg. (P/A)	Pol. (H/V)
802.11a CH 36 5180MHz		10360	52.82	-15.48	68.3	66.54	37.47	11.87	63.06	100	360	P	H
		10360	51.89	-16.41	68.3	65.61	37.47	11.87	63.06	100	360	P	V
802.11a CH 44 5220MHz		10440	50.28	-18.02	68.3	63.89	37.5	11.93	63.04	100	360	P	H
		10440	51.44	-16.86	68.3	65.05	37.5	11.93	63.04	100	360	P	V
802.11a CH 48 5240MHz		10480	50.2	-18.1	68.3	63.73	37.53	11.97	63.03	100	360	P	H
		10480	50.65	-17.65	68.3	64.18	37.53	11.97	63.03	100	360	P	V
Remark	1. No other spurious found. 2. All results are PASS against Peak and Average limit line.												



Band 1 5150~5250MHz

WIFI 802.11ac VHT20 (Band Edge @ 3m)

WIFI Ant. 1	Note	Frequency (MHz)	Level (dBμV/m)	Over Limit (dB)	Limit Line (dBμV/m)	Read Level (dBμV)	Antenna Factor (dB/m)	Cable Loss (dB)	Preamp Factor (dB)	Ant Pos (cm)	Table Pos (deg)	Peak Avg. (P/A)	Pol. (H/V)
802.11ac VHT20 CH 36 5180MHz		5140.64	54.02	-19.98	74	47.32	35.06	8.14	36.5	117	119	P	H
		5149.76	43.02	-10.98	54	36.32	35.06	8.14	36.5	117	119	A	H
	*	5184	104.39	-	-	97.63	35.08	8.17	36.49	117	119	P	H
		5184	97.07	-	-	90.31	35.08	8.17	36.49	117	119	A	H
		5147.2	52.62	-21.38	74	45.92	35.06	8.14	36.5	107	111	P	V
		5148.64	41.28	-12.72	54	34.58	35.06	8.14	36.5	107	111	A	V
	*	5184	100.43	-	-	93.67	35.08	8.17	36.49	107	111	P	V
		5184	93.33	-	-	86.57	35.08	8.17	36.49	107	111	A	V
Remark	1. No other spurious found. 2. All results are PASS against Peak and Average limit line.												



Band 1 5150~5250MHz

WIFI 802.11ac VHT20 (Harmonic @ 3m)

WIFI Ant. 1	Note	Frequency (MHz)	Level (dBμV/m)	Over Limit (dB)	Limit Line (dBμV/m)	Read Level (dBμV)	Antenna Factor (dB/m)	Cable Loss (dB)	Preamp Factor (dB)	Ant Pos (cm)	Table Pos (deg)	Peak Avg. (P/A)	Pol. (H/V)
802.11ac VHT20 CH 36 5180MHz		10360	48.38	-19.92	68.3	62.1	37.47	11.87	63.06	100	360	P	H
802.11ac VHT20 CH 44 5220MHz		10440	50.66	-17.64	68.3	64.27	37.5	11.93	63.04	100	360	P	H
802.11ac VHT20 CH 48 5240MHz		10480	49.61	-18.69	68.3	63.14	37.53	11.97	63.03	100	360	P	H
802.11ac VHT20 CH 36 5180MHz		10360	49.06	-19.24	68.3	62.78	37.47	11.87	63.06	100	360	P	V
802.11ac VHT20 CH 44 5220MHz		10440	50.57	-17.73	68.3	64.18	37.5	11.93	63.04	100	360	P	V
802.11ac VHT20 CH 48 5240MHz		10480	50.28	-18.02	68.3	63.81	37.53	11.97	63.03	100	360	P	V
Remark	1. No other spurious found. 2. All results are PASS against Peak and Average limit line.												



Band 1 5150~5250MHz

WIFI 802.11ac VHT40 (Band Edge @ 3m)

WIFI Ant. 1	Note	Frequency (MHz)	Level (dBμV/m)	Over Limit (dB)	Limit Line (dBμV/m)	Read Level (dBμV)	Antenna Factor (dB/m)	Cable Loss (dB)	Preamp Factor (dB)	Ant Pos (cm)	Table Pos (deg)	Peak Avg. (P/A)	Pol. (H/V)
802.11ac VHT40 CH 38 5190MHz		5148.64	56.52	-17.48	74	49.82	35.06	8.14	36.5	108	115	P	H
		5149.98	46.39	-7.61	54	39.69	35.06	8.14	36.5	108	115	A	H
	*	5194	101.21	-	-	94.41	35.09	8.2	36.49	108	115	P	H
		5194	93.97	-	-	87.17	35.09	8.2	36.49	108	115	A	H
		5369.94	49.36	-24.64	74	42.34	35.17	8.3	36.45	108	115	P	H
		5374.8	39.62	-14.38	54	32.6	35.17	8.3	36.45	108	115	A	H
		5145.76	52.19	-21.81	74	45.49	35.06	8.14	36.5	100	35	P	V
		5149.76	43.1	-10.9	54	36.4	35.06	8.14	36.5	100	35	A	V
	*	5194	98.43	-	-	91.63	35.09	8.2	36.49	100	35	P	V
		5194	90.37	-	-	83.57	35.09	8.2	36.49	100	35	A	V
		5388.84	48.64	-25.36	74	41.59	35.18	8.32	36.45	100	35	P	V
		5356.98	39.45	-14.55	54	32.44	35.16	8.3	36.45	100	35	A	V
Remark	1. No other spurious found. 2. All results are PASS against Peak and Average limit line.												



Band 1 5150~5250MHz

WIFI 802.11ac VHT40 (Harmonic @ 3m)

WIFI Ant. 1	Note	Frequency (MHz)	Level (dBμV/m)	Over Limit (dB)	Limit Line (dBμV/m)	Read Level (dBμV)	Antenna Factor (dB/m)	Cable Loss (dB)	Preamp Factor (dB)	Ant Pos (cm)	Table Pos (deg)	Peak Avg. (P/A)	Pol. (H/V)
802.11ac VHT40 CH 38 5190MHz		10380	46.98	-21.32	68.3	60.65	37.48	11.9	63.05	100	360	P	H
802.11ac VHT40 CH 46 5230MHz		10380	47.01	-21.29	68.3	60.68	37.48	11.9	63.05	100	360	P	V
802.11ac VHT40 CH 46 5230MHz		10460	47.64	-20.66	68.3	61.2	37.51	11.97	63.04	100	360	P	H
802.11ac VHT40 CH 46 5230MHz		10460	48.66	-19.64	68.3	62.22	37.51	11.97	63.04	100	360	P	V
Remark	1. No other spurious found. 2. All results are PASS against Peak and Average limit line.												



Band 1 5150~5250MHz

WIFI 802.11ac VHT80 (Band Edge @ 3m)

WIFI Ant. 1	Note	Frequency (MHz)	Level (dBμV/m)	Over Limit (dB)	Limit Line (dBμV/m)	Read Level (dBμV)	Antenna Factor (dB/m)	Cable Loss (dB)	Preamp Factor (dB)	Ant Pos (cm)	Table Pos (deg)	Peak Avg. (P/A)	Pol. (H/V)
802.11ac VHT80 CH 42 5210MHz		5146.08	57.57	-16.43	74	50.87	35.06	8.14	36.5	122	114	P	H
		5148.48	46.11	-7.89	54	39.41	35.06	8.14	36.5	122	114	A	H
	*	5204	94.61	-	-	87.81	35.09	8.2	36.49	122	114	P	H
		5204	87.66	-	-	80.86	35.09	8.2	36.49	122	114	A	H
		5390.1	49.82	-24.18	74	42.77	35.18	8.32	36.45	122	114	P	H
		5369.22	39.78	-14.22	54	32.76	35.17	8.3	36.45	122	114	A	H
		5149.92	57.44	-16.56	74	50.74	35.06	8.14	36.5	100	35	P	V
		5149.92	43.44	-10.56	54	36.74	35.06	8.14	36.5	100	35	A	V
	*	5216	92.67	-	-	85.85	35.1	8.2	36.48	100	35	P	V
		5216	85.65	-	-	78.83	35.1	8.2	36.48	100	35	A	V
		5376.6	49.13	-24.87	74	42.11	35.17	8.3	36.45	100	35	P	V
		5373	39.85	-14.15	54	32.83	35.17	8.3	36.45	100	35	A	V
Remark	1. No other spurious found. 2. All results are PASS against Peak and Average limit line.												



Band 1 5150~5250MHz

WIFI 802.11ac VHT80 (Harmonic @ 3m)

WIFI Ant. 1	Note	Frequency (MHz)	Level (dBμV/m)	Over Limit (dB)	Limit Line (dBμV/m)	Read Level (dBμV)	Antenna Factor (dB/m)	Cable Loss (dB)	Preamp Factor (dB)	Ant Pos (cm)	Table Pos (deg)	Peak Avg. (P/A)	Pol. (H/V)
802.11ac VHT80 CH 42 5210MHz		10420	45.3	-23	68.3	58.92	37.5	11.93	63.05	100	360	P	H
		10420	43.51	-24.79	68.3	57.13	37.5	11.93	63.05	100	360	P	V
Remark	1. No other spurious found. 2. All results are PASS against Peak and Average limit line.												



Band 2 - 5250~5350MHz

WIFI 802.11a (Band Edge @ 3m)

WIFI	Note	Frequency	Level	Over	Limit	Read	Antenna	Cable	Preamp	Ant	Table	Peak	Pol.
Ant.				Limit	Line	Level	Factor	Loss	Factor	Pos	Pos	Avg.	
1		(MHz)	(dBμV/m)	(dB)	(dBμV/m)	(dBμV)	(dB/m)	(dB)	(dB)	(cm)	(deg)	(P/A)	(H/V)
802.11a CH 64 5320MHz	*	5322	102.77	-	-	95.81	35.15	8.27	36.46	116	113	P	H
		5322	95.53	-	-	88.57	35.15	8.27	36.46	116	113	A	H
		5355.8	52.76	-21.24	74	45.75	35.16	8.3	36.45	116	113	P	H
		5351.9	42.33	-11.67	54	35.32	35.16	8.3	36.45	116	113	A	H
	*	5318	100.31	-	-	93.35	35.15	8.27	36.46	100	123	P	V
		5318	92.58	-	-	85.62	35.15	8.27	36.46	100	123	A	V
		5363.6	50.11	-23.89	74	43.09	35.17	8.3	36.45	100	123	P	V
		5350.4	40.63	-13.37	54	33.62	35.16	8.3	36.45	100	123	A	V
Remark	1. No other spurious found. 2. All results are PASS against Peak and Average limit line.												



Band 2 5250~5350MHz

WIFI 802.11a (Harmonic @ 3m)

WIFI Ant. 1	Note	Frequency (MHz)	Level (dBμV/m)	Over Limit (dB)	Limit Line (dBμV/m)	Read Level (dBμV)	Antenna Factor (dB/m)	Cable Loss (dB)	Preamp Factor (dB)	Ant Pos (cm)	Table Pos (deg)	Peak Avg. (P/A)	Pol. (H/V)
802.11a CH 52 5260MHz		10520	49.85	-18.45	68.3	63.34	37.54	12	63.03	100	360	P	H
		10520	50.44	-17.86	68.3	63.93	37.54	12	63.03	100	360	P	V
802.11a CH 60 5300MHz		10600	50.12	-23.88	74	63.49	37.58	12.06	63.01	100	360	P	H
		10600	52.57	-21.43	74	65.94	37.58	12.06	63.01	117	104	P	V
		10600	44.42	-9.58	54	57.79	37.58	12.06	63.01	117	104	A	V
802.11a CH 64 5320MHz		10640	49.47	-24.53	74	62.78	37.6	12.09	63	100	360	P	H
		10640	54.16	-19.84	74	67.47	37.6	12.09	63	115	104	P	V
		10640	44.93	-9.07	54	58.24	37.6	12.09	63	115	104	A	V
Remark	1. No other spurious found. 2. All results are PASS against Peak and Average limit line.												



Band 2 5250~5350MHz

WIFI 802.11n HT20 (Band Edge @ 3m)

WIFI Ant. 1	Note	Frequency (MHz)	Level (dBμV/m)	Over Limit (dB)	Limit Line (dBμV/m)	Read Level (dBμV)	Antenna Factor (dB/m)	Cable Loss (dB)	Preamp Factor (dB)	Ant Pos (cm)	Table Pos (deg)	Peak Avg. (P/A)	Pol. (H/V)
802.11n HT20 CH 64 5320MHz		5355.6	51.36	-22.64	74	44.35	35.16	8.3	36.45	116	116	P	H
		5351.7	41.24	-12.76	54	34.23	35.16	8.3	36.45	116	116	A	H
	*	5318	102.46	-	-	95.5	35.15	8.27	36.46	116	116	P	H
		5318	95.3	-	-	88.34	35.15	8.27	36.46	116	116	A	H
		5357.2	49.96	-24.04	74	42.95	35.16	8.3	36.45	100	331	P	V
		5350	39.78	-14.22	54	32.77	35.16	8.3	36.45	100	331	A	V
	*	5318	99.33	-	-	92.37	35.15	8.27	36.46	100	331	P	V
		5318	92.7	-	-	85.74	35.15	8.27	36.46	100	331	A	V
Remark	1. No other spurious found. 2. All results are PASS against Peak and Average limit line.												



Band 2 5250~5350MHz

WIFI 802.11n HT20 (Harmonic @ 3m)

WIFI Ant. 1	Note	Frequency (MHz)	Level (dBμV/m)	Over Limit (dB)	Limit Line (dBμV/m)	Read Level (dBμV)	Antenna Factor (dB/m)	Cable Loss (dB)	Preamp Factor (dB)	Ant Pos (cm)	Table Pos (deg)	Peak Avg. (P/A)	Pol. (H/V)
802.11n HT20 CH 52		10520	51.03	-17.27	68.3	64.52	37.54	12	63.03	100	360	P	H
5260MHz		10520	50.51	-17.79	68.3	64	37.54	12	63.03	100	360	P	V
802.11n HT20 CH 60		10600	50.19	-23.81	74	63.56	37.58	12.06	63.01	100	360	P	H
5300MHz		10600	48.61	-25.39	74	61.98	37.58	12.06	63.01	100	360	P	V
802.11n HT20 CH 64		10640	49.54	-24.46	74	62.85	37.6	12.09	63	100	360	P	H
5320MHz		10640	50.57	-23.43	74	63.88	37.6	12.09	63	100	360	P	V
Remark	1. No other spurious found. 2. All results are PASS against Peak and Average limit line.												



Band 2 5250~5350MHz

WIFI 802.11ac VHT40 (Band Edge @ 3m)

WIFI Ant. 1	Note	Frequency (MHz)	Level (dBμV/m)	Over Limit (dB)	Limit Line (dBμV/m)	Read Level (dBμV)	Antenna Factor (dB/m)	Cable Loss (dB)	Preamp Factor (dB)	Ant Pos (cm)	Table Pos (deg)	Peak Avg. (P/A)	Pol. (H/V)
802.11ac VHT40 CH 62 5310MHz		5113.28	50.44	-23.56	74	43.8	35.05	8.1	36.51	128	112	P	H
		5140.8	40.43	-13.57	54	33.73	35.06	8.14	36.5	128	112	A	H
	*	5312	98.99	-	-	92.03	35.15	8.27	36.46	128	112	P	H
		5312	91.57	-	-	84.61	35.15	8.27	36.46	128	112	A	H
		5351.2	53.99	-20.01	74	46.98	35.16	8.3	36.45	128	112	P	H
		5350.2	46.61	-7.39	54	39.6	35.16	8.3	36.45	128	112	A	H
		5102.88	50.2	-23.8	74	43.57	35.04	8.1	36.51	123	14	P	V
		5117.92	40.56	-13.44	54	33.88	35.05	8.14	36.51	123	14	A	V
	*	5312	96.4	-	-	89.44	35.15	8.27	36.46	123	14	P	V
		5312	89.28	-	-	82.32	35.15	8.27	36.46	123	14	A	V
		5350.8	52.73	-21.27	74	45.72	35.16	8.3	36.45	123	14	P	V
		5350.1	43.82	-10.18	54	36.81	35.16	8.3	36.45	123	14	A	V
Remark	1. No other spurious found. 2. All results are PASS against Peak and Average limit line.												



Band 2 5250~5350MHz

WIFI 802.11ac VHT40 (Harmonic @ 3m)

WIFI Ant. 1	Note	Frequency (MHz)	Level (dBμV/m)	Over Limit (dB)	Limit Line (dBμV/m)	Read Level (dBμV)	Antenna Factor (dB/m)	Cable Loss (dB)	Preamp Factor (dB)	Ant Pos (cm)	Table Pos (deg)	Peak Avg. (P/A)	Pol. (H/V)
802.11ac VHT40 CH 54 5270MHz		10540	47.13	-21.17	68.3	60.57	37.55	12.03	63.02	100	360	P	H
802.11ac VHT40 CH 62 5310MHz		10540	48.2	-20.1	68.3	61.64	37.55	12.03	63.02	100	360	P	V
802.11ac VHT40 CH 54 5270MHz		10620	46.45	-27.55	74	59.78	37.59	12.09	63.01	100	360	P	H
802.11ac VHT40 CH 62 5310MHz		10620	46.56	-27.44	74	59.89	37.59	12.09	63.01	100	360	P	V
Remark	1. No other spurious found. 2. All results are PASS against Peak and Average limit line.												



Band 2 5250~5350MHz

WIFI 802.11ac VHT80 (Band Edge @ 3m)

WIFI Ant. 1	Note	Frequency (MHz)	Level (dBμV/m)	Over Limit (dB)	Limit Line (dBμV/m)	Read Level (dBμV)	Antenna Factor (dB/m)	Cable Loss (dB)	Preamp Factor (dB)	Ant Pos (cm)	Table Pos (deg)	Peak Avg. (P/A)	Pol. (H/V)
802.11ac VHT80 CH 58 5290MHz		5124.96	50.38	-23.62	74	43.68	35.06	8.14	36.5	115	116	P	H
		5140.8	41.02	-12.98	54	34.32	35.06	8.14	36.5	115	116	A	H
	*	5284	93.43	-	-	86.52	35.13	8.25	36.47	115	116	P	H
		5284	86.38	-	-	79.47	35.13	8.25	36.47	115	116	A	H
		5351.8	60.98	-13.02	74	53.97	35.16	8.3	36.45	115	116	P	H
		5352.4	45.01	-8.99	54	38	35.16	8.3	36.45	115	116	A	H
		5147.36	50.31	-23.69	74	43.61	35.06	8.14	36.5	100	33	P	V
		5111.2	40.72	-13.28	54	34.08	35.05	8.1	36.51	100	33	A	V
	*	5296	91.75	-	-	84.83	35.14	8.25	36.47	100	33	P	V
		5296	84.04	-	-	77.12	35.14	8.25	36.47	100	33	A	V
		5359.8	60.5	-13.5	74	53.49	35.16	8.3	36.45	100	33	P	V
		5353.1	44.16	-9.84	54	37.15	35.16	8.3	36.45	100	33	A	V
Remark	1. No other spurious found. 2. All results are PASS against Peak and Average limit line.												



Band 2 5250~5350MHz

WIFI 802.11ac VHT80 (Harmonic @ 3m)

WIFI Ant. 1	Note	Frequency (MHz)	Level (dBμV/m)	Over Limit (dB)	Limit Line (dBμV/m)	Read Level (dBμV)	Antenna Factor (dB/m)	Cable Loss (dB)	Preamp Factor (dB)	Ant Pos (cm)	Table Pos (deg)	Peak Avg. (P/A)	Pol. (H/V)
802.11ac VHT80		10580	42.86	-25.44	68.3	56.23	37.58	12.06	63.01	100	360	P	H
CH 58 5290MHz		10580	44.87	-23.43	68.3	58.24	37.58	12.06	63.01	100	360	P	V
Remark	1. No other spurious found. 2. All results are PASS against Peak and Average limit line.												



Band 3 - 5470~5725MHz

WIFI 802.11a (Band Edge @ 3m)

WIFI	Note	Frequency	Level	Over	Limit	Read	Antenna	Cable	Preamp	Ant	Table	Peak	Pol.
Ant.				Limit	Line	Level	Factor	Loss	Factor	Pos	Pos	Avg.	
1		(MHz)	(dBμV/m)	(dB)	(dBμV/m)	(dBμV)	(dB/m)	(dB)	(dB)	(cm)	(deg)	(P/A)	(H/V)
802.11a CH 100 5500MHz		5459.28	50.13	-23.87	74	42.99	35.21	8.36	36.43	115	120	P	H
		5465.68	54.88	-13.42	68.3	47.69	35.22	8.4	36.43	115	120	P	H
		5459.92	41.74	-12.26	54	34.6	35.21	8.36	36.43	115	120	A	H
	*	5498	104.48	-	-	97.26	35.24	8.4	36.42	115	120	P	H
		5498	96.49	-	-	89.27	35.24	8.4	36.42	115	120	A	H
		5456.88	49.48	-24.52	74	42.34	35.21	8.36	36.43	100	115	P	V
		5464.88	53.01	-15.29	68.3	45.86	35.22	8.36	36.43	100	115	P	V
		5459.76	40.5	-13.5	54	33.36	35.21	8.36	36.43	100	115	A	V
	*	5500	101.42	-	-	94.2	35.24	8.4	36.42	100	115	P	V
		5500	93.74	-	-	86.52	35.24	8.4	36.42	100	115	A	V
802.11a CH 140 5700MHz	*	5696	104.05	-	-	96.64	35.25	8.58	36.42	112	119	P	H
		5696	97.06	-	-	89.65	35.25	8.58	36.42	112	119	A	H
		5744.76	55.67	-12.63	68.3	48.26	35.21	8.64	36.44	112	119	P	H
	*	5698	100.09	-	-	92.68	35.25	8.58	36.42	100	118	P	V
		5698	93.35	-	-	85.94	35.25	8.58	36.42	100	118	A	V
		5737.64	53.05	-15.25	68.3	45.67	35.21	8.61	36.44	100	118	P	V
Remark	1. No other spurious found. 2. All results are PASS against Peak and Average limit line.												



Band 3 - 5470~5725MHz
WIFI 802.11a (Harmonic @ 3m)

Table with 14 columns: WIFI Ant. 1, Note, Frequency (MHz), Level (dBµV/m), Over Limit (dB), Limit Line (dBµV/m), Read Level (dBµV), Antenna Factor (dB/m), Cable Loss (dB), Preamp Factor (dB), Ant Pos (cm), Table Pos (deg), Peak Avg. (P/A), Pol. (H/V). Rows include channels 100, 116, and 140 with their respective frequency and measurement data.



Band 3 - 5470~5725MHz
WIFI 802.11n HT20 (Band Edge @ 3m)

WIFI Ant. 1	Note	Frequency (MHz)	Level (dBμV/m)	Over Limit (dB)	Limit Line (dBμV/m)	Read Level (dBμV)	Antenna Factor (dB/m)	Cable Loss (dB)	Preamp Factor (dB)	Ant Pos (cm)	Table Pos (deg)	Peak Avg. (P/A)	Pol. (H/V)
802.11n HT20 CH 100 5500MHz		5458.64	51.98	-22.02	74	44.84	35.21	8.36	36.43	109	116	P	H
		5467.12	51.9	-16.4	68.3	44.71	35.22	8.4	36.43	109	116	P	H
		5459.98	42	-12	54	34.86	35.21	8.36	36.43	109	116	A	H
	*	5498	104.19	-	-	96.97	35.24	8.4	36.42	109	116	P	H
		5498	96.62	-	-	89.4	35.24	8.4	36.42	109	116	A	H
		5450.16	50.17	-23.83	74	43.03	35.21	8.36	36.43	100	30	P	V
		5467.44	51.01	-17.29	68.3	43.82	35.22	8.4	36.43	100	30	P	V
		5459.92	40.55	-13.45	54	33.41	35.21	8.36	36.43	100	30	A	V
	*	5498	100.64	-	-	93.42	35.24	8.4	36.42	100	30	P	V
	5498	93.36	-	-	86.14	35.24	8.4	36.42	100	30	A	V	
802.11n HT20 CH 140 5700MHz	*	5704	103.37	-	-	95.94	35.24	8.61	36.42	111	116	P	H
		5704	96.21	-	-	88.78	35.24	8.61	36.42	111	116	A	H
		5725.32	54.38	-13.92	68.3	46.98	35.22	8.61	36.43	111	116	P	H
	*	5702	100.75	-	-	93.32	35.24	8.61	36.42	100	8	P	V
		5702	92.83	-	-	85.4	35.24	8.61	36.42	100	8	A	V
	5742.76	52.65	-15.65	68.3	45.24	35.21	8.64	36.44	100	8	P	V	
Remark	1. No other spurious found. 2. All results are PASS against Peak and Average limit line.												



Band 3 - 5470~5725MHz

WIFI 802.11n HT20 (Harmonic @ 3m)

WIFI Ant. 1	Note	Frequency (MHz)	Level (dBμV/m)	Over Limit (dB)	Limit Line (dBμV/m)	Read Level (dBμV)	Antenna Factor (dB/m)	Cable Loss (dB)	Preamp Factor (dB)	Ant Pos (cm)	Table Pos (deg)	Peak Avg. (P/A)	Pol. (H/V)
802.11n HT20 CH 100		11000	44.62	-29.38	74	57.42	37.76	12.37	62.93	100	360	P	H
5500MHz		11000	45.21	-28.79	74	58.01	37.76	12.37	62.93	100	360	P	V
802.11n HT20 CH 116		11160	43.56	-30.44	74	56.11	37.84	12.51	62.9	100	360	P	H
5580MHz		11160	44.5	-29.5	74	57.05	37.84	12.51	62.9	100	360	P	V
802.11n HT20 CH 140		11400	43.98	-30.02	74	56.2	37.95	12.68	62.85	100	360	P	H
5700MHz		11400	43.44	-30.56	74	55.66	37.95	12.68	62.85	100	360	P	V
Remark	1. No other spurious found. 2. All results are PASS against Peak and Average limit line.												



Band 3 - 5470~5725MHz
WIFI 802.11ac VHT40 (Band Edge @ 3m)

Table with 14 columns: WIFI Ant. 1, Note, Frequency (MHz), Level (dBµV/m), Over Limit (dB), Limit Line (dBµV/m), Read Level (dBµV), Antenna Factor (dB/m), Cable Loss (dB), Preamp Factor (dB), Ant Pos (cm), Table Pos (deg), Peak Avg. (P/A), Pol. (H/V). Rows include test data for 802.11ac VHT40 CH 102 (5510MHz) and CH 134 (5670MHz).



Band 3 - 5470~5725MHz

WIFI 802.11ac VHT40 (Harmonic @ 3m)

WIFI Ant. 1	Note	Frequency (MHz)	Level (dBμV/m)	Over Limit (dB)	Limit Line (dBμV/m)	Read Level (dBμV)	Antenna Factor (dB/m)	Cable Loss (dB)	Preamp Factor (dB)	Ant Pos (cm)	Table Pos (deg)	Peak Avg. (P/A)	Pol. (H/V)
802.11ac VHT40 CH 102 5510MHz		11020	43.18	-30.82	74	55.94	37.77	12.4	62.93	100	360	P	H
802.11ac VHT40 CH 110 5550MHz		11100	43.48	-30.52	74	56.13	37.81	12.45	62.91	100	360	P	H
802.11ac VHT40 CH 134 5670MHz		11340	43.21	-30.79	74	55.53	37.92	12.62	62.86	100	360	P	H
802.11ac VHT40 CH 102 5510MHz		11020	43.25	-30.75	74	56.01	37.77	12.4	62.93	100	360	P	V
802.11ac VHT40 CH 110 5550MHz		11100	43.65	-30.35	74	56.3	37.81	12.45	62.91	100	360	P	V
802.11ac VHT40 CH 134 5670MHz		11340	43.44	-30.56	74	55.76	37.92	12.62	62.86	100	360	P	V
Remark	1. No other spurious found. 2. All results are PASS against Peak and Average limit line.												



Band 3 5470~5725MHz

WIFI 802.11ac VHT80 (Band Edge @ 3m)

WIFI Ant. 1	Note	Frequency (MHz)	Level (dBμV/m)	Over Limit (dB)	Limit Line (dBμV/m)	Read Level (dBμV)	Antenna Factor (dB/m)	Cable Loss (dB)	Preamp Factor (dB)	Ant Pos (cm)	Table Pos (deg)	Peak Avg. (P/A)	Pol. (H/V)
802.11ac VHT80 CH 106 5530MHz		5451.92	52.78	-21.22	74	45.64	35.21	8.36	36.43	114	116	P	H
		5470	56.77	-11.53	68.3	49.58	35.22	8.4	36.43	114	116	P	H
		5455.28	44.27	-9.73	54	37.13	35.21	8.36	36.43	114	116	A	H
	*	5526	92.44	-	-	85.18	35.24	8.44	36.42	114	116	P	H
		5526	85.21	-	-	77.95	35.24	8.44	36.42	114	116	A	H
		5752.6	50.95	-17.35	68.3	43.57	35.19	8.64	36.45	114	116	P	H
		5452.56	53.97	-20.03	74	46.83	35.21	8.36	36.43	101	103	P	V
		5466.64	54.92	-13.38	68.3	47.73	35.22	8.4	36.43	101	103	P	V
		5458.96	44.39	-9.61	54	37.25	35.21	8.36	36.43	101	103	A	V
	*	5538	93.93	-	-	86.65	35.25	8.44	36.41	101	103	P	V
		5538	86.89	-	-	79.61	35.25	8.44	36.41	101	103	A	V
		5737.24	50.4	-17.9	68.3	43.02	35.21	8.61	36.44	101	103	P	V
Remark	1. No other spurious found. 2. All results are PASS against Peak and Average limit line.												



Band 3 5470~5725MHz

WIFI 802.11ac VHT80 (Harmonic @ 3m)

WIFI Ant. 1	Note	Frequency (MHz)	Level (dBμV/m)	Over Limit (dB)	Limit Line (dBμV/m)	Read Level (dBμV)	Antenna Factor (dB/m)	Cable Loss (dB)	Preamp Factor (dB)	Ant Pos (cm)	Table Pos (deg)	Peak Avg. (P/A)	Pol. (H/V)
802.11ac VHT80		11060	42.35	-31.65	74	55.05	37.8	12.42	62.92	100	360	P	H
CH 106 5530MHz		11060	43.76	-30.24	74	56.46	37.8	12.42	62.92	100	360	P	V
Remark	1. No other spurious found. 2. All results are PASS against Peak and Average limit line.												



Emission below 1GHz

WIFI 802.11n HT40 (LF @ 3m)

WIFI	Note	Frequency	Level	Over	Limit	Read	Antenna	Cable	Preamp	Ant	Table	Peak	Pol.
Ant.		(MHz)	(dBμV/m)	(dB)	(dBμV/m)	(dBμV)	(dB/m)	(dB)	(dB)	(cm)	(deg)	(P/A)	(H/V)
802.11n HT40 LF	1	30	18.13	-21.87	40	24.91	24.5	0.63	31.91	-	-	P	H
		354.95	22.73	-23.27	46	30.9	20.44	2.08	30.69	-	-	P	H
		839.95	24.77	-21.23	46	23.2	26.04	3.2	27.67	-	-	P	H
		868.08	25.02	-20.98	46	23.03	26.21	3.25	27.47	-	-	P	H
		920.46	26.22	-19.78	46	23.34	26.62	3.34	27.08	100	36	P	H
		968.96	26.1	-27.9	54	22.18	27.16	3.44	26.68	-	-	P	H
		31.94	17.49	-22.51	40	25.38	23.36	0.65	31.9	-	-	P	V
		42.61	18.21	-21.79	40	31.92	17.44	0.75	31.9	-	-	P	V
		93.05	18.44	-25.06	43.5	33.47	15.67	1.07	31.77	-	-	P	V
		880.69	25.33	-20.67	46	23.17	26.28	3.27	27.39	100	30	P	V
		971.87	25.83	-28.17	54	21.86	27.19	3.44	26.66	-	-	P	V
	996.12	26.41	-27.59	54	21.94	27.46	3.49	26.48	-	-	P	V	
Remark	1. No other spurious found. 2. All results are PASS against limit line.												



Note symbol

*	Fundamental Frequency which can be ignored. However, the level of any unwanted emissions shall not exceed the level of the fundamental frequency.
!	Test result is over limit line.
P/A	Peak or Average
H/V	Horizontal or Vertical



A calculation example for radiated spurious emission is shown as below:

WIFI	Note	Frequency	Level	Over	Limit	Read	Antenna	Cable	Preamp	Ant	Table	Peak	Pol.
Ant.				Limit	Line	Level	Factor	Loss	Factor	Pos	Pos	Avg.	
1		(MHz)	(dBμV/m)	(dB)	(dBμV/m)	(dBμV)	(dB/m)	(dB)	(dB)	(cm)	(deg)	(P/A)	(H/V)
802.11b		2390	55.45	-18.55	74	54.51	32.22	4.58	35.86	103	308	P	H
CH 01		2390	43.54	-10.46	54	42.6	32.22	4.58	35.86	103	308	A	H
2412MHz													

- Level(dBμV/m) =
Antenna Factor(dB/m) + Cable Loss(dB) + Read Level(dBμV) - Preamp Factor(dB)
- Over Limit(dB) = Level(dBμV/m) – Limit Line(dBμV/m)

For Peak Limit @ 2390MHz:

- Level(dBμV/m)
= Antenna Factor(dB/m) + Cable Loss(dB) + Read Level(dBμV) - Preamp Factor(dB)
= 32.22(dB/m) + 4.58(dB) + 54.51(dBμV) – 35.86 (dB)
= 55.45 (dBμV/m)
- Over Limit(dB)
= Level(dBμV/m) – Limit Line(dBμV/m)
= 55.45(dBμV/m) – 74(dBμV/m)
= -18.55(dB)

For Average Limit @ 2390MHz:

- Level(dBμV/m)
= Antenna Factor(dB/m) + Cable Loss(dB) + Read Level(dBμV) - Preamp Factor(dB)
= 32.22(dB/m) + 4.58(dB) + 42.6(dBμV) – 35.86 (dB)
= 43.54 (dBμV/m)
- Over Limit(dB)
= Level(dBμV/m) – Limit Line(dBμV/m)
= 43.54(dBμV/m) – 54(dBμV/m)
= -10.46(dB)

Both peak and average measured complies with the limit line, so test result is “PASS”.



Appendix D. Duty Cycle Plots

Band	Duty Cycle(%)	T(ms)	1/T(kHz)	VBW Setting
802.11a	97.92	2.044	0.489	0.51KHz
802.11n HT20	98.51	-	-	10Hz
802.11ac VHT20	98.15	-	-	10Hz
802.11ac VHT40	96.30	0.942	1.062	1.1KHz
802.11ac VHT80	93.26	0.461	2.170	2.2KHz

802.11a

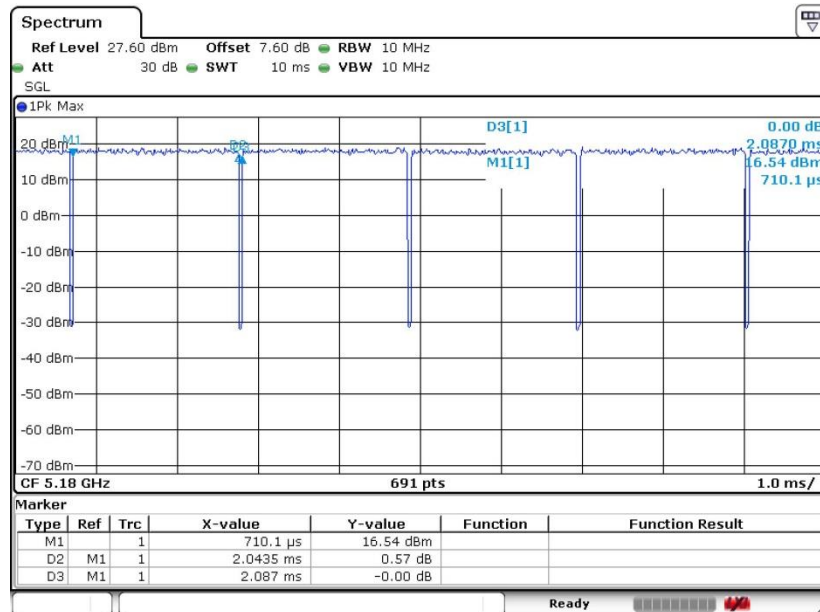



802.11n HT20

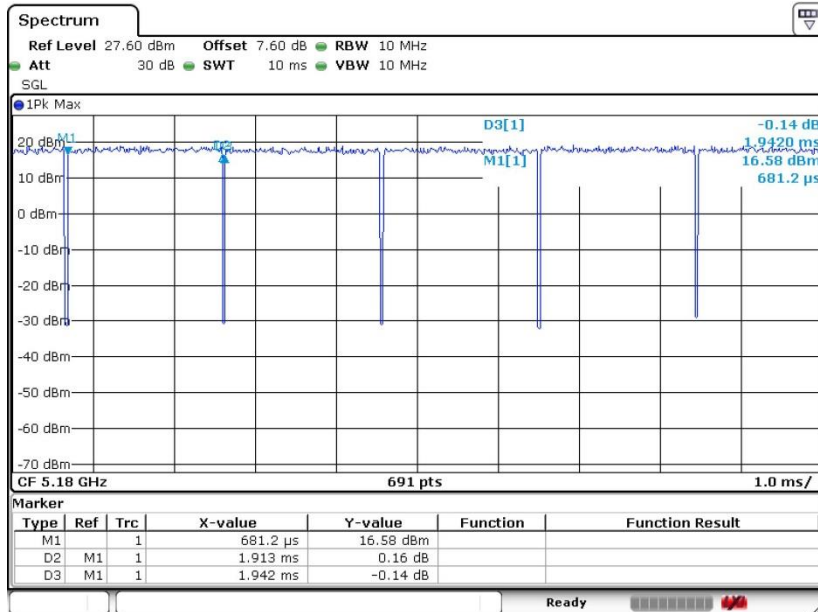

802.11ac VHT20

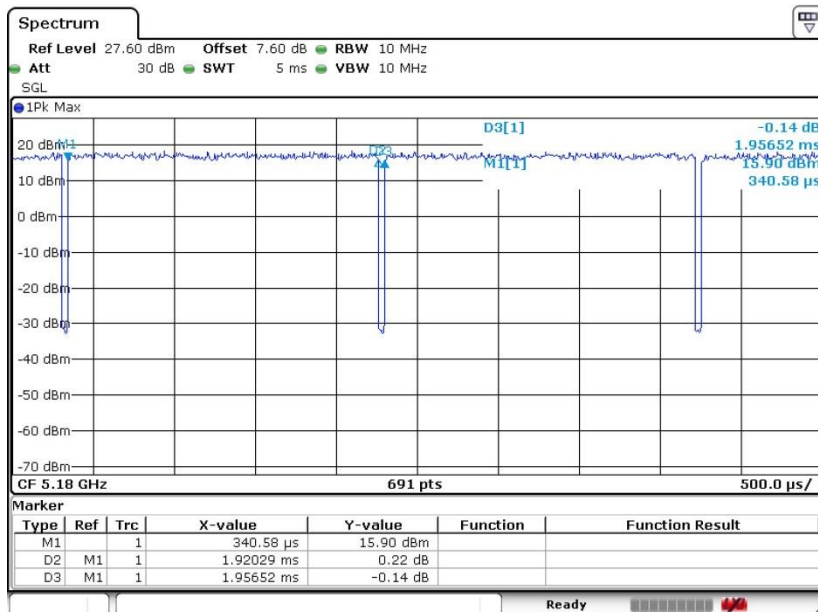



802.11ac VHT40

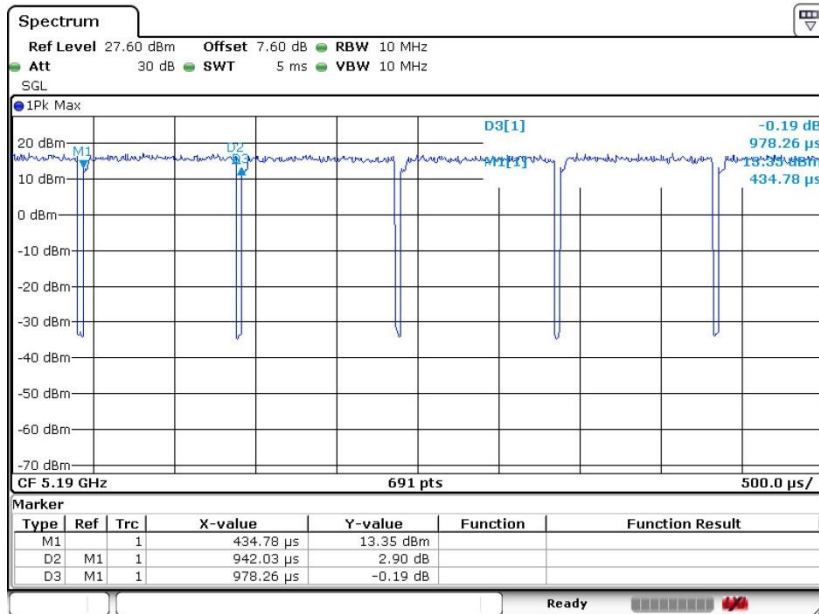

802.11ac VHT80

