

FCC Test Report

Report No.: RF160316C04-4

FCC ID: 2AFZZ-RT3161

Test Model: 2015161

Received Date: Mar. 16, 2016

Test Date: Mar. 19, 2016 ~ Apr. 22, 2016

Issued Date: Apr. 22, 2016

Applicant: Xiaomi Communications Co., Ltd.

Address: The Rainbow City of China Resources, NO.68, Qinghe Middle Street,
Haidian District, Beijing, China

Issued By: Bureau Veritas Consumer Products Services (H.K.) Ltd., Taoyuan Branch

Lab Address: No. 47-2, 14th Ling, Chia Pau Vil., Lin Kou Dist., New Taipei City, Taiwan
(R.O.C)

Test Location (1): No. 19, Hwa Ya 2nd Rd, Wen Hwa Tsuen, Kwei Shan Hsiang, Taoyuan
Hsien 333, Taiwan, R.O.C.

Test Location (2): No.215, Sec. 3, Beixin Rd., Xindian Dist., New Taipei City 231, Taiwan,
R.O.C



This report is for your exclusive use. Any copying or replication of this report to or for any other person or entity, or use of our name or trademark, is permitted only with our prior written permission. This report sets forth our findings solely with respect to the test samples identified herein. The results set forth in this report are not indicative or representative of the quality or characteristics of the lot from which a test sample was taken or any similar or identical product unless specifically and expressly noted. Our report includes all of the tests requested by you and the results thereof based upon the information that you provided to us. You have 60 days from date of issuance of this report to notify us of any material error or omission caused by our negligence, provided, however, that such notice shall be in writing and shall specifically address the issue you wish to raise. A failure to raise such issue within the prescribed time shall constitute your unqualified acceptance of the completeness of this report, the tests conducted and the correctness of the report contents. Unless specific mention, the uncertainty of measurement has been explicitly taken into account to declare the compliance or non-compliance to the specification. The report must not be used by the client to claim product certification, approval, or endorsement by TAF or any government agencies.

Table of Contents

Release Control Record	4
1 Certificate of Conformity	5
2 Summary of Test Results	6
2.1 Measurement Uncertainty	6
2.2 Modification Record	6
3 General Information	7
3.1 General Description of EUT	7
3.2 Description of Test Modes	9
3.2.1 Test Mode Applicability and Tested Channel Detail	11
3.3 Duty Cycle of Test Signal	13
3.4 Description of Support Units	17
3.4.1 Configuration of System under Test	17
3.5 General Description of Applied Standards	17
4 Test Types and Results	18
4.1 Radiated Emission and Bandedge Measurement	18
4.1.1 Limits of Radiated Emission and Bandedge Measurement	18
4.1.2 Limits of Unwanted Emission Out of the Restricted Bands	18
4.1.3 Test Instruments	19
4.1.4 Test Procedures	20
4.1.5 Deviation from Test Standard	20
4.1.6 Test Set Up	21
4.1.7 EUT Operating Conditions	21
4.1.8 Test Results	22
4.2 Conducted Emission Measurement	72
4.2.1 Limits of Conducted Emission Measurement	72
4.2.2 Test Instruments	72
4.2.3 Test Procedures	73
4.2.4 Deviation from Test Standard	73
4.2.5 Test Setup	73
4.2.6 EUT Operating Conditions	73
4.2.7 Test Results	74
4.3 Transmit Power Measurement	78
4.3.1 Limits of Transmit Power Measurement	78
4.3.2 Test Setup	78
4.3.3 Test Instruments	79
4.3.4 Test Procedure	79
4.3.5 Deviation from Test Standard	79
4.3.6 EUT Operating Conditions	79
4.3.7 Test Result	80
4.4 Peak Power Spectral Density Measurement	86
4.4.1 Limits of Peak Power Spectral Density Measurement	86
4.4.2 Test Setup	86
4.4.3 Test Instruments	86
4.4.4 Test Procedures	87
4.4.5 Deviation from Test Standard	87
4.4.6 EUT Operating Conditions	87
4.4.7 Test Results	88
4.5 Frequency Stability	93
4.5.1 Limit of Frequency Stability Measurement	93
4.5.2 Test Setup	93
4.5.3 Test Instruments	93
4.5.4 Test Procedure	93
4.5.5 Deviation from Test Standard	93



4.5.6 EUT Operating Condition	93
4.5.7 Test Results	94
4.6 6 dB Bandwidth Measurement.....	95
4.6.1 Limits of 6 dB Bandwidth Measurement.....	95
4.6.2 Test Setup.....	95
4.6.3 Test Instruments	95
4.6.4 Test Procedure	95
4.6.5 Deviation from Test Standard	95
4.6.6 EUT Operating Condition	95
4.6.7 Test Results	96
5 Pictures of Test Arrangements.....	98
Appendix – Information on the Testing Laboratories	99



Release Control Record

Issue No.	Description	Date Issued
RF160316C04-4	Original Release	Apr. 22, 2016



1 Certificate of Conformity

Product: Mobile phone
Brand: MI
Test Model: 2015161
Sample Status: Identical Prototype
Applicant: Xiaomi Communications Co., Ltd.
Test Date: Mar. 19, 2016 ~ Apr. 22, 2016
Standards: 47 CFR FCC Part 15, Subpart E (Section 15.407)
ANSI C63.10:2013

The above equipment has been tested by **Bureau Veritas Consumer Products Services (H.K.) Ltd., Taoyuan Branch**, and found compliance with the requirement of the above standards. The test record, data evaluation & Equipment Under Test (EUT) configurations represented herein are true and accurate accounts of the measurements of the sample's EMC characteristics under the conditions specified in this report.

Prepared by : Evonne Liu , **Date:** Apr. 22, 2016
Evonne Liu / Specialist

Approved by : Stanley Wu , **Date:** Apr. 22, 2016
Stanley Wu / Assistant Manager

2 Summary of Test Results

47 CFR FCC Part 15, Subpart E (Section 15.407)			
FCC Clause	Test Item	Result	Remarks
15.407(b)(6)	AC Power Conducted Emissions	Pass	Meet the requirement of limit. Minimum passing margin is -6.16 dB at 0.60603 MHz.
15.407(b) (1/2/3/4/6)	Radiated Emissions & Band Edge Measurement	Pass	Meet the requirement of limit. Minimum passing margin is -8.59 dB at 34.86 MHz.
15.407(a)(1/2 /3)	Max Average Transmit Power	Pass	Meet the requirement of limit.
15.407(a)(1/2 /3)	Peak Power Spectral Density	Pass	Meet the requirement of limit.
15.407(e)	6 dB Bandwidth	Pass	Meet the requirement of limit. (U-NII-3 Band only)
15.407(g)	Frequency Stability	Pass	Meet the requirement of limit.
15.203	Antenna Requirement	Pass	No antenna connector is used.

2.1 Measurement Uncertainty

Where relevant, the following measurement uncertainty levels have been estimated for tests performed on the EUT as specified in CISPR 16-4-2:

Measurement	Frequency	Expanded Uncertainty (k=2) (±)
Conducted Emissions at mains ports	150 kHz ~ 30 MHz	2.44 dB
Radiated Emissions up to 1 GHz	30 MHz ~ 200 MHz	2.0153 dB
	200 MHz ~ 1000 MHz	2.0224 dB
Radiated Emissions above 1 GHz	1 GHz ~ 18 GHz	1.0121 dB
	18 GHz ~ 40 GHz	1.1508 dB

2.2 Modification Record

There were no modifications required for compliance.

3 General Information

3.1 General Description of EUT

Product	Mobile phone
Brand	MI
Test Model	2015161
Status of EUT	Identical Prototype
Power Supply Rating	5.0 Vdc (adapter or host equipment) 3.85Vdc (Li-ion battery)
Modulation Type	256QAM, 64QAM, 16QAM, QPSK, BPSK
Modulation Technology	OFDM
Transfer Rate	802.11a: 54.0/ 48.0/ 36.0/ 24.0/ 18.0/ 12.0/ 9.0/ 6.0 Mbps 802.11n: up to MCS7 802.11ac: up to V9
Operating Frequency	5180 ~ 5240 MHz, 5260 ~ 5320 MHz, 5500 ~ 5700 MHz, 5745 ~ 5825 MHz
Number of Channel	5180 ~ 5240 MHz: 4 for 802.11a, 802.11n (HT20) 2 for 802.11n (HT40) 1 for 802.11ac (VHT80) 5260 ~ 5320 MHz: 4 for 802.11a, 802.11n (HT20) 2 for 802.11n (HT40) 1 for 802.11ac (VHT80) 5500 ~ 5700 MHz: 11 for 802.11a, 802.11n (HT20) 5 for 802.11n (HT40) 2 for 802.11ac (VHT80) 5745 ~ 5825 MHz: 5 for 802.11a, 802.11n (HT20) 2 for 802.11n (HT40) 1 for 802.11ac (VHT80)
Output Power	19.41 mW for 5180 ~ 5240 MHz 19.68 mW for 5260 ~ 5320 MHz 18.54 mW for 5500 ~ 5700 MHz 17.30 mW for 5745 ~ 5825 MHz
Antenna Type	LDS antenna with -3.97 dBi gain (5180 ~ 5240 MHz) LDS antenna with -3.73 dBi gain (5260 ~ 5320 MHz) LDS antenna with -3.18 dBi gain (5500 ~ 5700 MHz) LDS antenna with -3.62 dBi gain (5745 ~ 5825 MHz)
Antenna Connector	N/A
Accessory Device	Refer to Note as below
Data Cable Supplied	Refer to Note as below

Note:

1. The EUT provides 1 completed transmitter and 1 receiver.

Modulation Mode	Tx Function
802.11a	1TX
802.11n (HT20)	1TX
802.11n (HT40)	1TX
802.11ac (VHT80)	1TX

* The modulation and bandwidth are similar for 802.11n mode for HT20 / HT40 and 802.11ac mode for HT20 / HT40, therefore investigated worst case to representative mode in test report. (Final test mode refer section 3.2.1)

2. The EUT contains following accessory devices.

Product	Brand	Model	Description
Adapter	MI	MDY-08-EF	I/P: 100-240Vac, 50/60Hz, 500mA O/P: 5Vdc, 2A
Battery	MI	BM46	3.85Vdc, 4000mAh
USB Cable	MI	N/A	1.15m shielded cable w/o core
eMMC 1 (=ROM 1)	N/A	N/A	16G
eMMC 2 (=ROM 2)	N/A	N/A	32G

3. There're 2 configurations for the EUT listed as below.

Main sample: EUT + eMMC 1 (16G)

2nd sample: EUT + eMMC 1 (32G)

✧ Only the worst case data was presented in the report.

4. The above EUT information is declared by manufacturer and for more detailed features description, please refer to the manufacturer's specifications or user's manual.

3.2 Description of Test Modes

FOR 5180 ~ 5240 MHz

4 channels are provided for 802.11a, 802.11n (HT20):

Channel	Frequency (MHz)	Channel	Frequency (MHz)
36	5180	44	5220
40	5200	48	5240

2 channels are provided for 802.11n (HT40):

Channel	Frequency (MHz)	Channel	Frequency (MHz)
38	5190	46	5230

1 channel is provided for 802.11ac (VHT80):

Channel	Frequency (MHz)
42	5210

FOR 5260 ~ 5320 MHz

4 channels are provided for 802.11a, 802.11n (HT20):

Channel	Frequency (MHz)	Channel	Frequency (MHz)
52	5260	60	5300
56	5280	64	5320

2 channels are provided for 802.11n (HT40):

Channel	Frequency (MHz)	Channel	Frequency (MHz)
54	5270	62	5310

1 channel is provided for 802.11ac (VHT80):

Channel	Frequency (MHz)
58	5290

FOR 5500 ~ 5700 MHz

11 channels are provided for 802.11a, 802.11n (HT20):

Channel	Frequency (MHz)	Channel	Frequency (MHz)
100	5500	124	5620
104	5520	128	5640
108	5540	132	5660
112	5560	136	5680
116	5580	140	5700
120	5600		

5 channels are provided for 802.11n (HT40):

Channel	Frequency (MHz)	Channel	Frequency (MHz)
102	5510	126	5630
110	5550	134	5670
118	5590		

2 channels are provided for 802.11ac (VHT80):

Channel	Frequency (MHz)	Channel	Frequency (MHz)
106	5530	122	5610

FOR 5745 ~ 5825 MHz:

5 channels are provided for 802.11a, 802.11n (HT20):

Channel	Frequency (MHz)	Channel	Frequency (MHz)
149	5745	161	5805
153	5765	165	5825
157	5785		

2 channels are provided for 802.11n (HT40):

Channel	Frequency (MHz)	Channel	Frequency (MHz)
151	5755	159	5795

1 channel is provided for 802.11ac (VHT80):

Channel	Frequency (MHz)
155	5775

3.2.1 Test Mode Applicability and Tested Channel Detail

EUT Configure Mode	Applicable To				Description
	RE \geq 1G	RE $<$ 1G	PLC	APCM	
A	√	√	√	√	Main sample
B	√	√	√	-	2nd sample

Where **RE \geq 1G**: Radiated Emission above 1 GHz **RE $<$ 1G**: Radiated Emission below 1 GHz
PLC: Power Line Conducted Emission **APCM**: Antenna Port Conducted Measurement

NOTE:

- The EUT had been pre-tested on the positioned of each 3 axis. The worst case was found when positioned on **Y-plane** in 5180-5240 & 5500-5700MHz and **Z-plane** in 5260-5320 & 5745-5825MHz.
- “-” means no effect.

Radiated Emission Test (Above 1 GHz):

- Pre-Scan has been conducted to determine the worst-case mode from all possible combinations between available modulations, data rates and antenna ports (if EUT with antenna diversity architecture).
- Following channel(s) was (were) selected for the final test as listed below.

EUT Configure Mode	Frequency Band (MHz)	Mode	Available Channel	Tested Channel	Modulation Technology	Modulation Type	Data Rate (Mbps)
A	5180-5240	802.11a	36 to 48	36, 44, 48	OFDM	BPSK	6.0
		802.11n (HT20)	36 to 48	36, 44, 48	OFDM	BPSK	MCS0
		802.11n (HT40)	38 to 46	38, 46	OFDM	BPSK	MCS0
		802.11ac (VHT80)	42	42	OFDM	BPSK	V0
	5260-5320	802.11a	52 to 64	52, 60, 64	OFDM	BPSK	6.0
		802.11n (HT20)	52 to 64	52, 60, 64	OFDM	BPSK	MCS0
		802.11n (HT40)	54 to 62	54, 62	OFDM	BPSK	MCS0
		802.11ac (VHT80)	58	58	OFDM	BPSK	V0
	5500-5700	802.11a	100 to 140	100, 116, 140	OFDM	BPSK	6.0
		802.11n (HT20)	100 to 140	100, 116, 140	OFDM	BPSK	MCS0
		802.11n (HT40)	102 to 134	102, 110, 134	OFDM	BPSK	MCS0
		802.11ac (VHT80)	106 to 122	106, 122	OFDM	BPSK	V0
	5745-5825	802.11a	149 to 165	149, 157, 165	OFDM	BPSK	6.0
		802.11n (HT20)	149 to 165	149, 157, 165	OFDM	BPSK	MCS0
		802.11n (HT40)	151 to 159	151, 159	OFDM	BPSK	MCS0
		802.11ac (VHT80)	155	155	OFDM	BPSK	V0
A, B	5180-5240	802.11ac (VHT80)	42	42	OFDM	BPSK	V0
	5260-5320	802.11ac (VHT80)	58	58	OFDM	BPSK	V0
	5500-5700	802.11ac (VHT80)	106 to 122	106	OFDM	BPSK	V0
	5745-5825	802.11n (HT20)	149 to 165	157	OFDM	BPSK	V0

Radiated Emission Test (Below 1 GHz):

- Pre-Scan has been conducted to determine the worst-case mode from all possible combinations between available modulations, data rates and antenna ports (if EUT with antenna diversity architecture).
- Following channel(s) was (were) selected for the final test as listed below.

EUT Configure Mode	Frequency Band (MHz)	Mode	Available Channel	Tested Channel	Modulation Technology	Modulation Type	Data Rate (Mbps)
A, B	5180-5240	802.11ac (VHT80)	42	42	OFDM	BPSK	V0
	5260-5320	802.11ac (VHT80)	58	58	OFDM	BPSK	V0
	5500-5700	802.11ac (VHT80)	106 to 122	106	OFDM	BPSK	V0
	5745-5825	802.11n (HT20)	149 to 165	157	OFDM	BPSK	V0



Power Line Conducted Emission Test:

- Pre-Scan has been conducted to determine the worst-case mode from all possible combinations between available modulations, data rates and antenna ports (if EUT with antenna diversity architecture).
- Following channel(s) was (were) selected for the final test as listed below.

EUT Configure Mode	Frequency Band (MHz)	Mode	Available Channel	Tested Channel	Modulation Technology	Modulation Type	Data Rate (Mbps)
A, B	5180-5240	802.11ac (VHT80)	42	42	OFDM	BPSK	V0

Antenna Port Conducted Measurement:

- This item includes all test value of each mode, but only includes spectrum plot of worst value of each mode.
- Pre-Scan has been conducted to determine the worst-case mode from all possible combinations between available modulations, data rates and antenna ports (if EUT with antenna diversity architecture).
- Following channel(s) was (were) selected for the final test as listed below.

EUT Configure Mode	Frequency Band (MHz)	Mode	Available Channel	Tested Channel	Modulation Technology	Modulation Type	Data Rate (Mbps)
A	5180-5240	802.11a	36 to 48	36, 44, 48	OFDM	BPSK	6.0
		802.11n (HT20)	36 to 48	36, 44, 48	OFDM	BPSK	MCS0
		802.11n (HT40)	38 to 46	38, 46	OFDM	BPSK	MCS0
		802.11ac (VHT80)	42	42	OFDM	BPSK	V0
	5260-5320	802.11a	52 to 64	52, 60, 64	OFDM	BPSK	6.0
		802.11n (HT20)	52 to 64	52, 60, 64	OFDM	BPSK	MCS0
		802.11n (HT40)	54 to 62	54, 62	OFDM	BPSK	MCS0
		802.11ac (VHT80)	58	58	OFDM	BPSK	V0
	5500-5700	802.11a	100 to 140	100, 116, 140	OFDM	BPSK	6.0
		802.11n (HT20)	100 to 140	100, 116, 140	OFDM	BPSK	MCS0
		802.11n (HT40)	102 to 134	102, 110, 134	OFDM	BPSK	MCS0
		802.11ac (VHT80)	106 to 122	106, 122	OFDM	BPSK	V0
	5745-5825	802.11a	149 to 165	149, 157, 165	OFDM	BPSK	6.0
		802.11n (HT20)	149 to 165	149, 157, 165	OFDM	BPSK	MCS0
		802.11n (HT40)	151 to 159	151, 159	OFDM	BPSK	MCS0
		802.11ac (VHT80)	155	155	OFDM	BPSK	V0

Test Condition:

Applicable To	Environmental Conditions	Input Power	Tested by
RE≥1G	25 deg. C, 65 % RH	120 Vac, 60 Hz	Karl Lee
RE<1G	25 deg. C, 65 % RH	120 Vac, 60 Hz	Charles Hsiao
PLC	25 deg. C, 65 % RH	120 Vac, 60 Hz	Toby Tian
APCM	25 deg. C, 65 % RH	3.8 Vdc	Taylor Liu

3.3 Duty Cycle of Test Signal

MODULATION TYPE: BPSK

Duty cycle of test signal is < 98 %, duty factor is required.

802.11a: Duty cycle = $1.346/1.554 = 0.866$, Duty factor = $10 * \log(1/0.866) = 0.62$

802.11n (HT20): Duty cycle = $961/1.169 = 0.821$, Duty factor = $10 * \log(1/0.821) = 0.85$

802.11n (HT40): Duty cycle = $456/689 = 0.662$, Duty factor = $10 * \log(1/0.662) = 1.79$

802.11ac (VHT80): Duty cycle = $216/448 = 0.482$, Duty factor = $10 * \log(1/0.482) = 3.17$

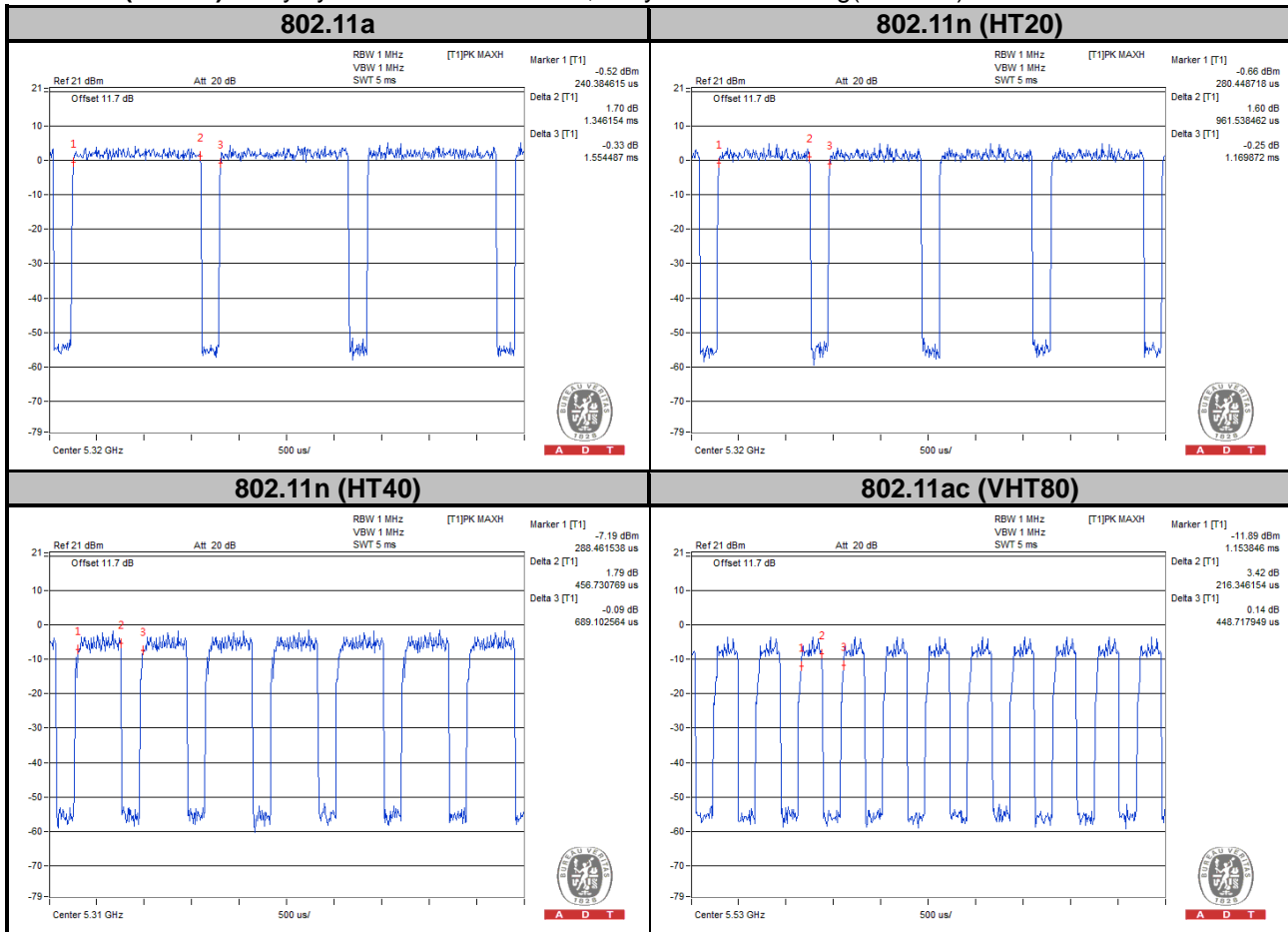

MODULATION TYPE: QPSK

Duty cycle of test signal is < 98 %, duty factor is required.

802.11a: Duty cycle = 681/889 = 0.765, Duty factor = $10 * \log(1/0.765) = 1.16$

802.11n (HT20): Duty cycle = 496/705 = 0.704, Duty factor = $10 * \log(1/0.704) = 1.52$

802.11n (HT40): Duty cycle = 224/464 = 0.482, Duty factor = $10 * \log(1/0.482) = 3.16$

802.11ac (VHT80): Duty cycle = 108/341 = 0.319, Duty factor = $10 * \log(1/0.319) = 4.96$

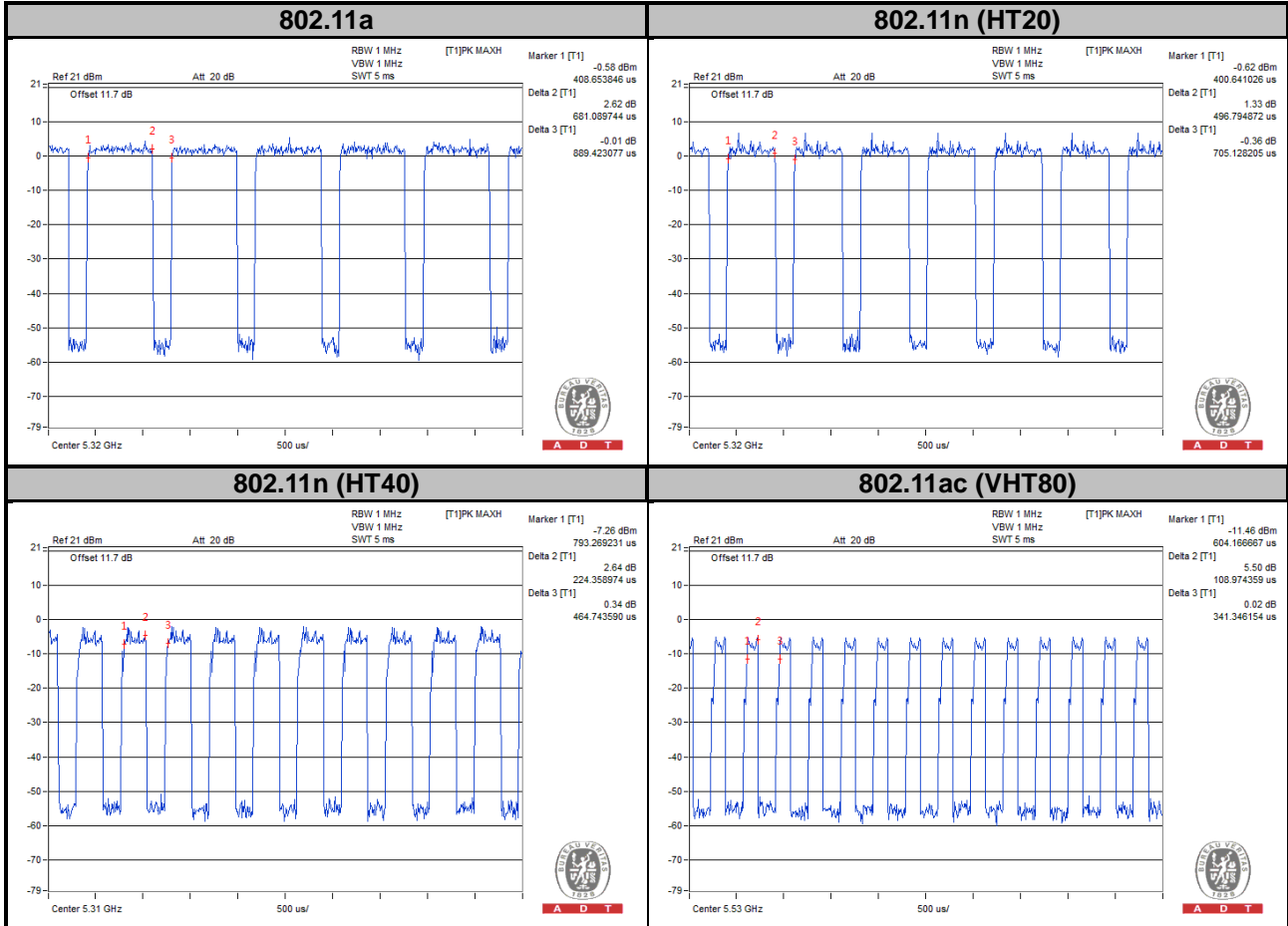

MODULATION TYPE: 16QAM

Duty cycle of test signal is < 98 %, duty factor is required.

802.11a: Duty cycle = 344/552 = 0.623, Duty factor = $10 * \log(1/0.623) = 2.05$

802.11n (HT20): Duty cycle = 264/480 = 0.550, Duty factor = $10 * \log(1/0.550) = 2.60$

802.11n (HT40): Duty cycle = 120/352 = 0.340, Duty factor = $10 * \log(1/0.340) = 4.67$

802.11ac (VHT80): Duty cycle = 60/293 = 0.207, Duty factor = $10 * \log(1/0.207) = 6.83$

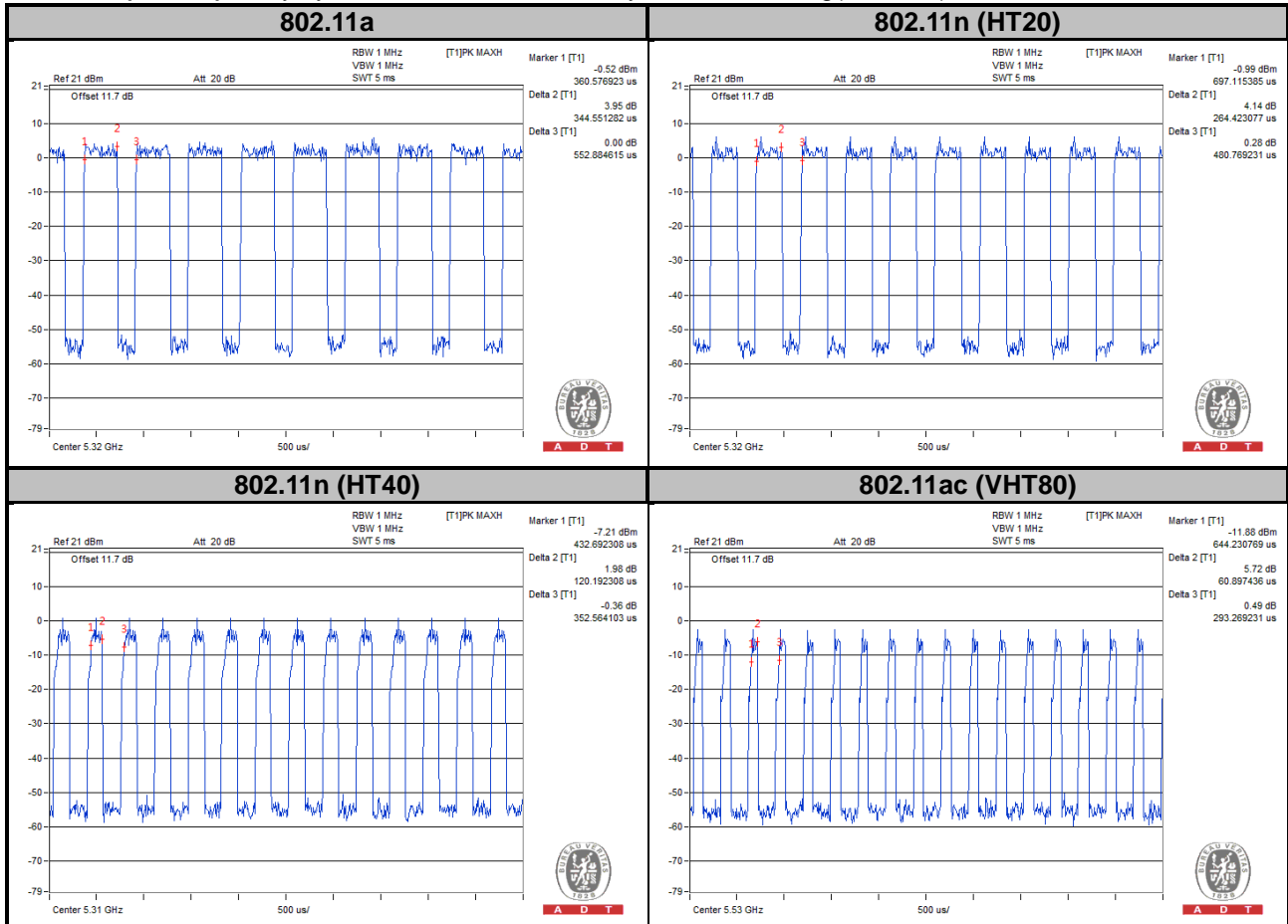

MODULATION TYPE: 64QAM

Duty cycle of test signal is < 98 %, duty factor is required.

802.11a: Duty cycle = 176/384 = 0.458, Duty factor = $10 * \log(1/0.458) = 3.39$

802.11n (HT20): Duty cycle = 152/360 = 0.422, Duty factor = $10 * \log(1/0.422) = 3.74$

802.11n (HT40): Duty cycle = 68/301 = 0.228, Duty factor = $10 * \log(1/0.228) = 6.41$

802.11ac (VHT80): Duty cycle = 35/267 = 0.131, Duty factor = $10 * \log(1/0.131) = 8.80$

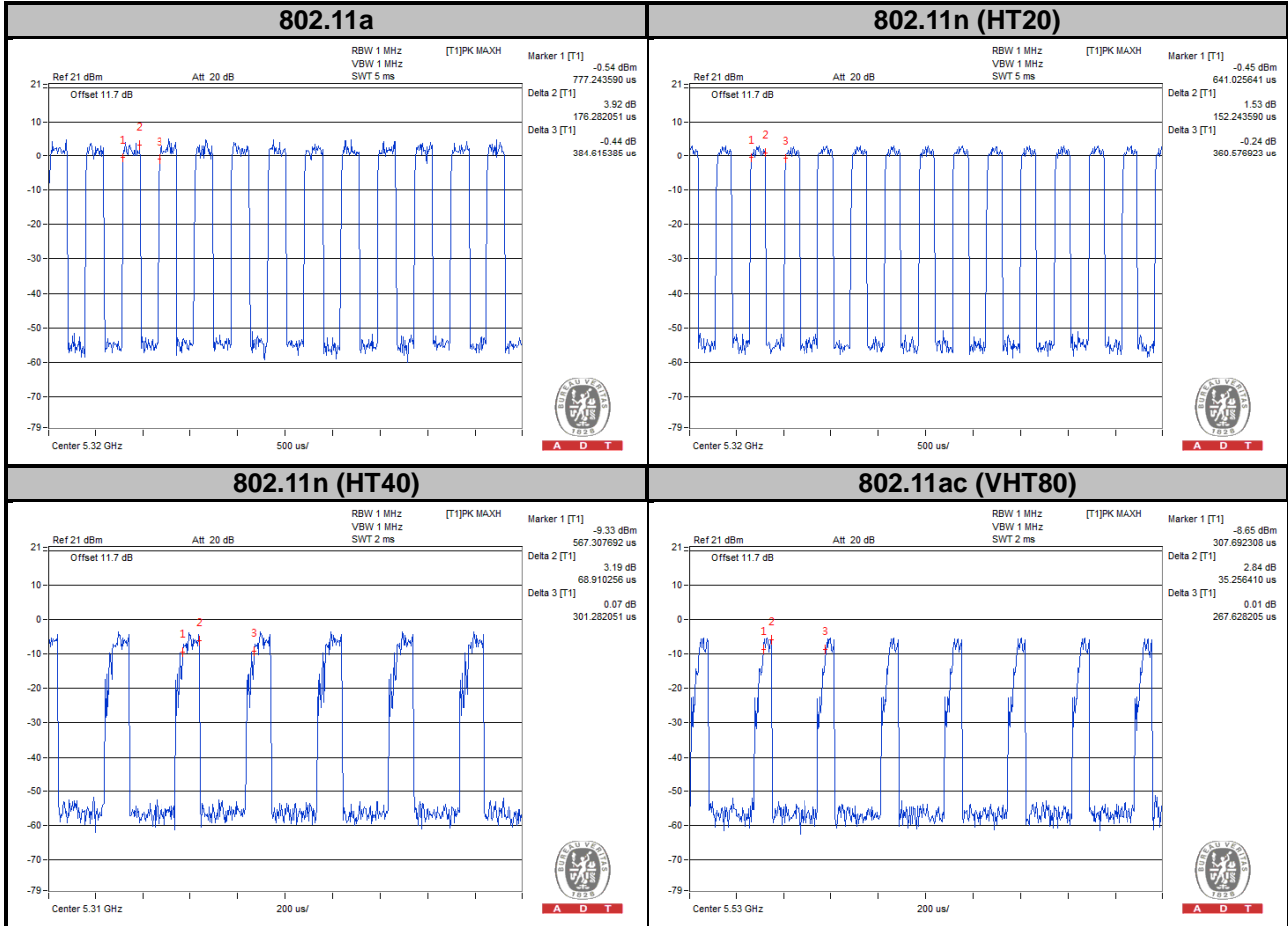

MODULATION TYPE: 256QAM

Duty cycle of test signal is < 98 %, duty factor is required.

802.11ac (VHT80): Duty cycle = 28/261 = 0.110, Duty factor = $10 * \log(1/0.110) = 9.57$

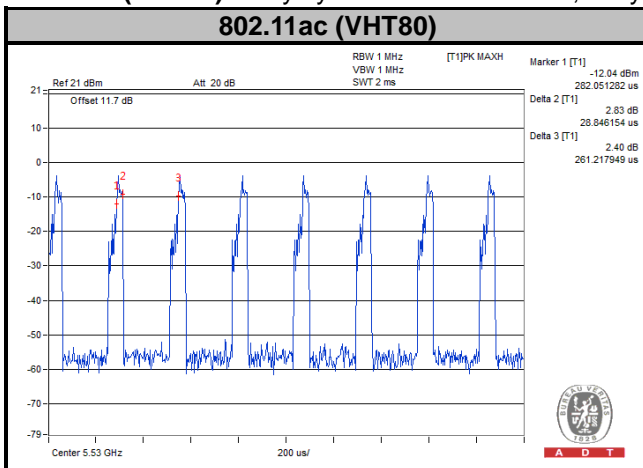

3.4 Description of Support Units

The EUT has been tested as an independent unit together with other necessary accessories or support units. The following support units or accessories were used to form a representative test configuration during the tests.

No.	Product	Brand	Model No.	Serial No.	FCC ID
1.	Earphone	N/A	N/A	N/A	N/A

No.	Signal Cable Description Of The Above Support Units
1.	1.2m non-shielded cable w/o core

Note:

1. All power cords of the above support units are non-shielded (1.8m).

3.4.1 Configuration of System under Test

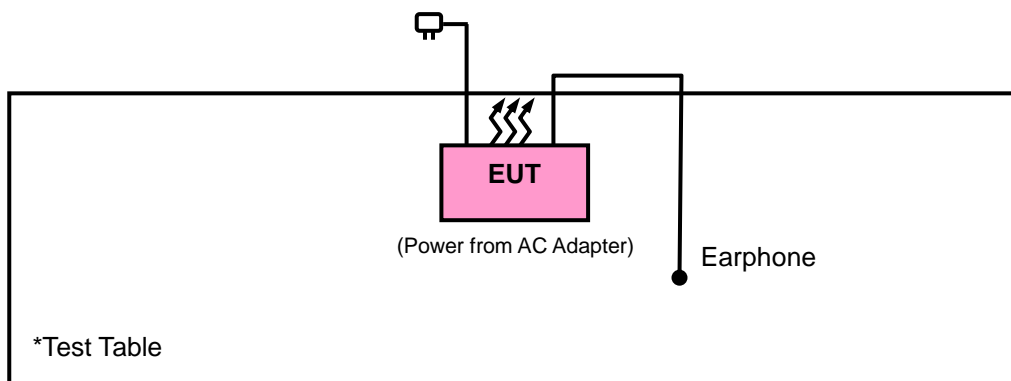

3.5 General Description of Applied Standards

The EUT is a RF Product. According to the specifications of the manufacturer, it must comply with the requirements of the following standards:

FCC Part 15, Subpart E (15.407)

789033 D02 General UNII Test Procedures New Rules v01r02

644545 D03 Guidance for IEEE 802 11ac v01

ANSI C63.10-2013

All test items have been performed and recorded as per the above standards.

NOTE: The EUT has been verified to comply with the requirements of FCC Part 15, Subpart B, Class B (FCC ID). The test report has been issued separately.

4 Test Types and Results

4.1 Radiated Emission and Bandedge Measurement

4.1.1 Limits of Radiated Emission and Bandedge Measurement

Radiated emissions which fall in the restricted bands must comply with the radiated emission limits specified as below table. Other emissions shall be at least 20 dB below the highest level of the desired power:

Frequencies (MHz)	Field Strength (microvolts/meter)	Measurement Distance (meters)
0.009 ~ 0.490	2400/F (kHz)	300
0.490 ~ 1.705	24000/F (kHz)	30
1.705 ~ 30.0	30	30
30 ~ 88	100	3
88 ~ 216	150	3
216 ~ 960	200	3
Above 960	500	3

NOTE:

1. The lower limit shall apply at the transition frequencies.
2. Emission level (dBuV/m) = 20 log Emission level (uV/m).
3. For frequencies above 1000 MHz, the field strength limits are based on average detector, however, the peak field strength of any emission shall not exceed the maximum permitted average limits, specified above by more than 20 dB under any condition of modulation.

4.1.2 Limits of Unwanted Emission Out of the Restricted Bands

Applicable To	Limit	
789033 D02 General UNII Test Procedures New Rules v01r02	Field Strength at 3 m	
	PK: 74 (dBµV/m)	AV: 54 (dBµV/m)
Applicable To	EIRP Limit	Equivalent Field Strength at 3 m
15.407(b)(1)	PK: -27 (dBm/MHz)	PK: 68.2 (dBµV/m)
15.407(b)(2)		
15.407(b)(3)		
15.407(b)(4)	PK: -27 (dBm/MHz) ^{*1} PK: -17 (dBm/MHz) ^{*2}	PK: 68.2 (dBµV/m) ^{*1} PK: 78.2 (dBµV/m) ^{*2}

NOTE: ^{*1} beyond 10 MHz of the band edge ^{*2} within 10 MHz of band edge

The following formula is used to convert the equipment isotropic radiated power (eirp) to field strength:

$$E = \frac{1000000\sqrt{30P}}{3} \mu\text{V/m, where } P \text{ is the eirp (Watts).}$$

4.1.3 Test Instruments

Description & Manufacturer	Model No.	Serial No.	Date of Calibration	Due Date of Calibration
Test Receiver Agilent Technologies	N9038A	MY52260177	May 19, 2015	May 18, 2016
Spectrum Analyzer ROHDE & SCHWARZ	FSU43	101261	Dec. 17, 2015	Dec. 16, 2016
BILOG Antenna SCHWARZBECK	VULB9168	9168-472	Jan. 07, 2016	Jan. 06, 2017
HORN Antenna ETS-Lindgren	3117	00143293	Jan. 19, 2016	Jan. 18, 2017
Bluetooth Tester	CBT	100980	Apr. 27, 2015	Apr. 26, 2017
Loop Antenna	EM-6879	269	Jul. 31, 2015	Jul. 30, 2016
Agilent Communications Tester-Wireless	8960 Series 10	MY53201073	Jul. 03, 2015	Jul. 02, 2017
Preamplifier Agilent	310N	187226	Jun. 29, 2015	Jun. 28, 2016
Preamplifier Agilent	83017A	MY39501357	Jun. 29, 2015	Jun. 28, 2016
HORN Antenna SCHWARZBECK	BBHA 9170	BBHA9170243	Jan. 20, 2016	Jan. 19, 2017
Power Meter Anritsu	ML2495A	1232002	Sep. 21, 2015	Sep. 20, 2016
Power Sensor Anritsu	MA2411B	1207325	Sep. 21, 2015	Sep. 20, 2016
RF signal cable ETS-LINDGREN	5D-FB	Cable-CH1-01(R FC-SMS-100-SM S-120+RFC-SMS -100-SMS-400)	Jun. 27, 2015	Jun. 26, 2016
RF signal cable ETS-LINDGREN	8D-FB	Cable-CH1-02(R FC-SMS-100-SM S-24)	Jun. 27, 2015	Jun. 26, 2016
Software BV ADT	E3 8.130425b	NA	NA	NA
Antenna Tower MF	NA	NA	NA	NA
Turn Table MF	NA	NA	NA	NA
Antenna Tower & Turn Table Controller MF	MF-7802	NA	NA	NA

- Note: 1. The calibration interval of the above test instruments is 12 / 24 months and the calibrations are traceable to NML/ROC and NIST/USA.
2. The test was performed in HsinTien Chamber 1.
3. The horn antenna and preamplifier (model: 83017A) are used only for the measurement of emission frequency above 1 GHz if tested.
4. The FCC Site Registration No. is 149147.
5. The IC Site Registration No. is IC7450I-1.

4.1.4 Test Procedures

- a. The EUT was placed on the top of a rotating table 0.8 meters (for below 1 GHz) / 1.5 meters (for above 1 GHz) above the ground at 3 meter chamber room for test. The table was rotated 360 degrees to determine the position of the highest radiation.
- b. The EUT was set 3 meters away from the interference-receiving antenna, which was mounted on the top of a variable-height antenna tower.
- c. The height of antenna is varied from one meter to four meters above the ground to determine the maximum value of the field strength. Both horizontal and vertical polarizations of the antenna are set to make the measurement.
- d. For each suspected emission, the EUT was arranged to its worst case and then the antenna was tuned to heights from 1 meter to 4 meters and the rotatable table was turned from 0 degrees to 360 degrees to find the maximum reading.
- e. The test-receiver system was set to quasi-peak detect function and specified bandwidth with maximum hold mode when the test frequency is below 1 GHz.
- f. The test-receiver system was set to peak and average detected function and specified bandwidth with maximum hold mode when the test frequency is above 1 GHz. If the peak reading value also meets average limit, measurement with the average detector is unnecessary.

Note:

1. The resolution bandwidth and video bandwidth of test receiver/spectrum analyzer is 120 kHz for Quasi-peak detection (QP) at frequency below 1 GHz.
2. The resolution bandwidth of test receiver/spectrum analyzer is 1 MHz and the video bandwidth is 3 MHz for Peak detection (PK) at frequency above 1 GHz.
3. The resolution bandwidth of test receiver/spectrum analyzer is 1 MHz and the video bandwidth is 3 MHz for RMS Average (Duty cycle < 98 %) for Average detection (AV) at frequency above 1 GHz, then the measurement results was added to a correction factor ($10 \log(1/\text{duty cycle})$).
4. The resolution bandwidth of test receiver/spectrum analyzer is 1 MHz and the video bandwidth is 10 Hz (Duty cycle ≥ 98 %) for Average detection (AV) at frequency above 1 GHz.
5. All modes of operation were investigated and the worst-case emissions are reported.

4.1.5 Deviation from Test Standard

No deviation.

4.1.6 Test Set Up

<Frequency Range below 1 GHz>

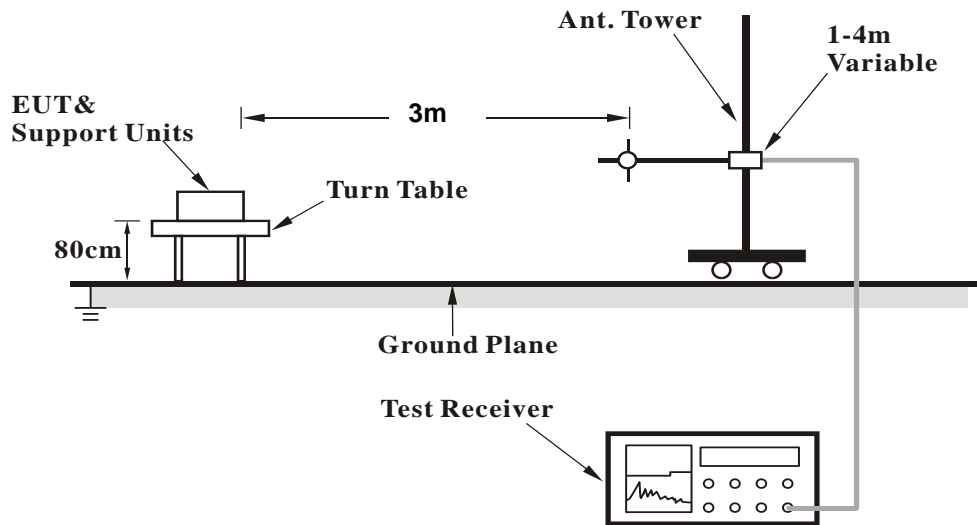

<Frequency Range above 1 GHz>

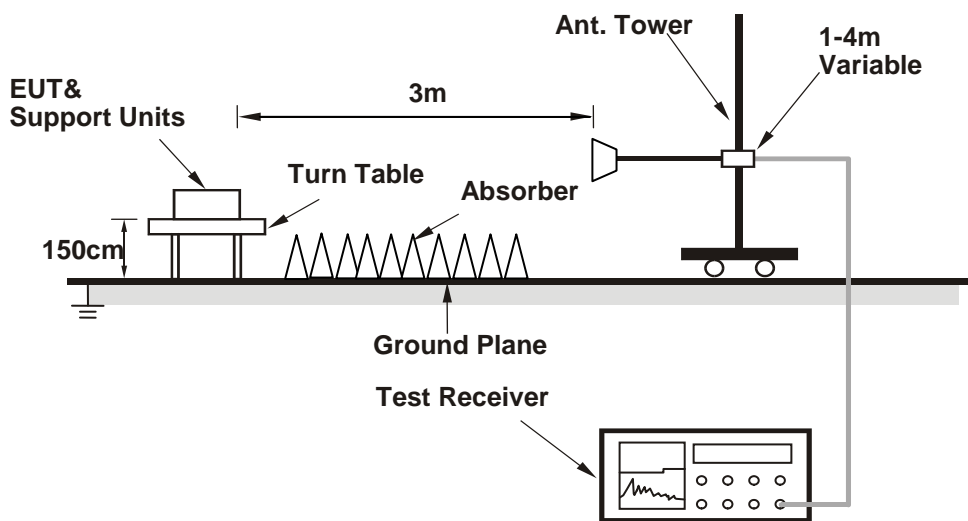

For the actual test configuration, please refer to the attached file (Test Setup Photo).

4.1.7 EUT Operating Conditions

- a. Placed the EUT on a testing table.
- b. Use the software to control the EUT under transmission condition continuously at specific channel frequency.

4.1.8 Test Results
Above 1 GHz Data :
802.11a
Mode A

EUT Test Condition		Measurement Detail	
Channel	Channel 36	Frequency Range	1 GHz ~ 40 GHz
Input Power	120 Vac, 60 Hz	Detector Function	Peak (PK) Average (AV)
Environmental Conditions	25 deg. C, 65 % RH	Tested By	Karl Lee

Antenna Polarity & Test Distance: Horizontal at 3 m

Frequency (MHz)	Emission Level (dBuV/m)	Read Level (dBuV)	Limit (dBuV/m)	Margin (dB)	Antenna Factor (dB/m)	Cable Loss (dB)	Preamp Factor (dB)	Antenna Height (cm)	Table Angle (Degree)	Remark
5108	44.16	35.96	54	-9.84	34.09	8.1	33.99	105	301	Average
5108	56.95	48.75	74	-17.05	34.09	8.1	33.99	105	301	Peak
5180	92.99	84.68			34.15	8.16	34	105	301	Average
5180	100.9	92.59			34.15	8.16	34	105	301	Peak
5442	42.4	33.61	54	-11.6	34.35	8.48	34.04	105	301	Average
5442	56.98	48.19	74	-17.02	34.35	8.48	34.04	105	301	Peak

Antenna Polarity & Test Distance: Vertical at 3 m

Frequency (MHz)	Emission Level (dBuV/m)	Read Level (dBuV)	Limit (dBuV/m)	Margin (dB)	Antenna Factor (dB/m)	Cable Loss (dB)	Preamp Factor (dB)	Antenna Height (cm)	Table Angle (Degree)	Remark
5088	42.98	34.82	54	-11.02	34.07	8.07	33.98	181	278	Average
5088	56.52	48.36	74	-17.48	34.07	8.07	33.98	181	278	Peak
5180	91.19	82.88			34.15	8.16	34	181	278	Average
5180	98.38	90.07			34.15	8.16	34	181	278	Peak
5456	42.51	33.69	54	-11.49	34.36	8.51	34.05	181	278	Average
5456	58.12	49.3	74	-15.88	34.36	8.51	34.05	181	278	Peak

Remarks:

- Emission Level = Read Level + Antenna Factor + Cable Loss - Preamp Factor
Margin value = Emission level – Limit value
- 5180 MHz: Fundamental Frequency

EUT Test Condition		Measurement Detail	
Channel	Channel 44	Frequency Range	1 GHz ~ 40 GHz
Input Power	120 Vac, 60 Hz	Detector Function	Peak (PK) Average (AV)
Environmental Conditions	25 deg. C, 65 % RH	Tested By	Karl Lee

Antenna Polarity & Test Distance: Horizontal at 3 m										
Frequency (MHz)	Emission Level (dBuV/m)	Read Level (dBuV)	Limit (dBuV/m)	Margin (dB)	Antenna Factor (dB/m)	Cable Loss (dB)	Preamp Factor (dB)	Antenna Height (cm)	Table Angle (Degree)	Remark
5148	43	34.75	54	-11	34.12	8.13	34	105	303	Average
5148	57.54	49.29	74	-16.46	34.12	8.13	34	105	303	Peak
5220	93.19	84.8			34.17	8.22	34	105	303	Average
5220	100.12	91.73			34.17	8.22	34	105	303	Peak
5350	42.29	33.66	54	-11.71	34.28	8.38	34.03	105	303	Average
5350	57.63	49	74	-16.37	34.28	8.38	34.03	105	303	Peak
Antenna Polarity & Test Distance: Vertical at 3 m										
Frequency (MHz)	Emission Level (dBuV/m)	Read Level (dBuV)	Limit (dBuV/m)	Margin (dB)	Antenna Factor (dB/m)	Cable Loss (dB)	Preamp Factor (dB)	Antenna Height (cm)	Table Angle (Degree)	Remark
5084	42.21	34.05	54	-11.79	34.07	8.07	33.98	171	276	Average
5084	56.77	48.61	74	-17.23	34.07	8.07	33.98	171	276	Peak
5220	90.16	81.77			34.17	8.22	34	171	276	Average
5220	98.29	89.9			34.17	8.22	34	171	276	Peak
5440	42.47	33.68	54	-11.53	34.35	8.48	34.04	171	276	Average
5440	57.43	48.64	74	-16.57	34.35	8.48	34.04	171	276	Peak

Remarks:

- Emission Level = Read Level + Antenna Factor + Cable Loss - Preamp Factor
Margin value = Emission level – Limit value
- 5220 MHz: Fundamental Frequency

EUT Test Condition		Measurement Detail	
Channel	Channel 48	Frequency Range	1 GHz ~ 40 GHz
Input Power	120 Vac, 60 Hz	Detector Function	Peak (PK) Average (AV)
Environmental Conditions	25 deg. C, 65 % RH	Tested By	Karl Lee

Antenna Polarity & Test Distance: Horizontal at 3 m										
Frequency (MHz)	Emission Level (dBuV/m)	Read Level (dBuV)	Limit (dBuV/m)	Margin (dB)	Antenna Factor (dB/m)	Cable Loss (dB)	Preamp Factor (dB)	Antenna Height (cm)	Table Angle (Degree)	Remark
5124	42.56	34.34	54	-11.44	34.11	8.1	33.99	103	303	Average
5124	56.31	48.09	74	-17.69	34.11	8.1	33.99	103	303	Peak
5240	93.58	85.14			34.19	8.26	34.01	103	303	Average
5240	100.74	92.3			34.19	8.26	34.01	103	303	Peak
5446	41.93	33.1	54	-12.07	34.36	8.51	34.04	103	303	Average
5446	56.77	47.94	74	-17.23	34.36	8.51	34.04	103	303	Peak
Antenna Polarity & Test Distance: Vertical at 3 m										
Frequency (MHz)	Emission Level (dBuV/m)	Read Level (dBuV)	Limit (dBuV/m)	Margin (dB)	Antenna Factor (dB/m)	Cable Loss (dB)	Preamp Factor (dB)	Antenna Height (cm)	Table Angle (Degree)	Remark
5030	42.12	34.06	54	-11.88	34.03	8	33.97	152	277	Average
5030	56.76	48.7	74	-17.24	34.03	8	33.97	152	277	Peak
5240	91.02	82.58			34.19	8.26	34.01	152	277	Average
5240	98.89	90.45			34.19	8.26	34.01	152	277	Peak
5444	42.33	33.54	54	-11.67	34.35	8.48	34.04	152	277	Average
5444	57.1	48.31	74	-16.9	34.35	8.48	34.04	152	277	Peak

Remarks:

- Emission Level = Read Level + Antenna Factor + Cable Loss - Preamp Factor
Margin value = Emission level – Limit value
- 5240 MHz: Fundamental Frequency



A D T

EUT Test Condition		Measurement Detail	
Channel	Channel 52	Frequency Range	1 GHz ~ 40 GHz
Input Power	120 Vac, 60 Hz	Detector Function	Peak (PK) Average (AV)
Environmental Conditions	25 deg. C, 65 % RH	Tested By	Karl Lee

Antenna Polarity & Test Distance: Horizontal at 3 m										
Frequency (MHz)	Emission Level (dBuV/m)	Read Level (dBuV)	Limit (dBuV/m)	Margin (dB)	Antenna Factor (dB/m)	Cable Loss (dB)	Preamp Factor (dB)	Antenna Height (cm)	Table Angle (Degree)	Remark
5050	41.71	33.65	54	-12.29	34.04	8	33.98	128	164	Average
5050	55.53	47.47	74	-18.47	34.04	8	33.98	128	164	Peak
5260	87.97	79.51			34.21	8.26	34.01	128	164	Average
5260	95.35	86.89			34.21	8.26	34.01	128	164	Peak
5450	42.54	33.72	54	-11.46	34.36	8.51	34.05	128	164	Average
5450	56.92	48.1	74	-17.08	34.36	8.51	34.05	128	164	Peak

Antenna Polarity & Test Distance: Vertical at 3 m										
Frequency (MHz)	Emission Level (dBuV/m)	Read Level (dBuV)	Limit (dBuV/m)	Margin (dB)	Antenna Factor (dB/m)	Cable Loss (dB)	Preamp Factor (dB)	Antenna Height (cm)	Table Angle (Degree)	Remark
5066	41.86	33.76	54	-12.14	34.05	8.03	33.98	101	359	Average
5066	55.32	47.22	74	-18.68	34.05	8.03	33.98	101	359	Peak
5260	93.47	85.01			34.21	8.26	34.01	101	359	Average
5260	101.05	92.59			34.21	8.26	34.01	101	359	Peak
5364	42.38	33.74	54	-11.62	34.29	8.38	34.03	101	359	Average
5364	56.01	47.37	74	-17.99	34.29	8.38	34.03	101	359	Peak

Remarks:

1. Emission Level = Read Level + Antenna Factor + Cable Loss - Preamp Factor
Margin value = Emission level – Limit value
2. 5260 MHz: Fundamental Frequency



A D T

EUT Test Condition		Measurement Detail	
Channel	Channel 60	Frequency Range	1 GHz ~ 40 GHz
Input Power	120 Vac, 60 Hz	Detector Function	Peak (PK) Average (AV)
Environmental Conditions	25 deg. C, 65 % RH	Tested By	Karl Lee

Antenna Polarity & Test Distance: Horizontal at 3 m										
Frequency (MHz)	Emission Level (dBuV/m)	Read Level (dBuV)	Limit (dBuV/m)	Margin (dB)	Antenna Factor (dB/m)	Cable Loss (dB)	Preamp Factor (dB)	Antenna Height (cm)	Table Angle (Degree)	Remark
5142	42	33.74	54	-12	34.12	8.13	33.99	141	164	Average
5142	57.21	48.95	74	-16.79	34.12	8.13	33.99	141	164	Peak
5300	87.99	79.45			34.24	8.32	34.02	141	164	Average
5300	95.25	86.71			34.24	8.32	34.02	141	164	Peak
5446	42.62	33.79	54	-11.38	34.36	8.51	34.04	141	164	Average
5446	57.4	48.57	74	-16.6	34.36	8.51	34.04	141	164	Peak

Antenna Polarity & Test Distance: Vertical at 3 m										
Frequency (MHz)	Emission Level (dBuV/m)	Read Level (dBuV)	Limit (dBuV/m)	Margin (dB)	Antenna Factor (dB/m)	Cable Loss (dB)	Preamp Factor (dB)	Antenna Height (cm)	Table Angle (Degree)	Remark
5136	41.98	33.73	54	-12.02	34.11	8.13	33.99	100	359	Average
5136	56.42	48.17	74	-17.58	34.11	8.13	33.99	100	359	Peak
5300	93.59	85.05			34.24	8.32	34.02	100	359	Average
5300	101	92.46			34.24	8.32	34.02	100	359	Peak
5430	42.43	33.64	54	-11.57	34.35	8.48	34.04	100	359	Average
5430	56.5	47.71	74	-17.5	34.35	8.48	34.04	100	359	Peak

Remarks:

- Emission Level = Read Level + Antenna Factor + Cable Loss - Preamp Factor
Margin value = Emission level – Limit value
- 5300 MHz: Fundamental Frequency



EUT Test Condition		Measurement Detail	
Channel	Channel 64	Frequency Range	1 GHz ~ 40 GHz
Input Power	120 Vac, 60 Hz	Detector Function	Peak (PK) Average (AV)
Environmental Conditions	25 deg. C, 65 % RH	Tested By	Karl Lee

Antenna Polarity & Test Distance: Horizontal at 3 m										
Frequency (MHz)	Emission Level (dBuV/m)	Read Level (dBuV)	Limit (dBuV/m)	Margin (dB)	Antenna Factor (dB/m)	Cable Loss (dB)	Preamp Factor (dB)	Antenna Height (cm)	Table Angle (Degree)	Remark
5116	41.79	33.59	54	-12.21	34.09	8.1	33.99	141	172	Average
5116	56.21	48.01	74	-17.79	34.09	8.1	33.99	141	172	Peak
5320	87.2	78.62			34.25	8.35	34.02	141	172	Average
5320	95.28	86.7			34.25	8.35	34.02	141	172	Peak
5360	42.56	33.93	54	-11.44	34.28	8.38	34.03	141	172	Average
5360	56.92	48.29	74	-17.08	34.28	8.38	34.03	141	172	Peak

Antenna Polarity & Test Distance: Vertical at 3 m										
Frequency (MHz)	Emission Level (dBuV/m)	Read Level (dBuV)	Limit (dBuV/m)	Margin (dB)	Antenna Factor (dB/m)	Cable Loss (dB)	Preamp Factor (dB)	Antenna Height (cm)	Table Angle (Degree)	Remark
5112	41.81	33.61	54	-12.19	34.09	8.1	33.99	100	358	Average
5112	55.89	47.69	74	-18.11	34.09	8.1	33.99	100	358	Peak
5320	93.15	84.57			34.25	8.35	34.02	100	358	Average
5320	101.48	92.9			34.25	8.35	34.02	100	358	Peak
5416	43.18	34.45	54	-10.82	34.33	8.44	34.04	100	358	Average
5416	57.13	48.4	74	-16.87	34.33	8.44	34.04	100	358	Peak

Remarks:

- Emission Level = Read Level + Antenna Factor + Cable Loss - Preamp Factor
Margin value = Emission level – Limit value
- 5320 MHz: Fundamental Frequency



EUT Test Condition		Measurement Detail	
Channel	Channel 100	Frequency Range	1 GHz ~ 40 GHz
Input Power	120 Vac, 60 Hz	Detector Function	Peak (PK) Average (AV)
Environmental Conditions	25 deg. C, 65 % RH	Tested By	Karl Lee

Antenna Polarity & Test Distance: Horizontal at 3 m										
Frequency (MHz)	Emissino Level (dBuV/m)	Read Level (dBuV)	Limit (dBuV/m)	Margin (dB)	Antenna Factor (dB/m)	Cable Loss (dB)	Preamp Factor (dB)	Antenna Height (cm)	Table Angle (Degree)	Remark
5460	42.72	33.9	54	-11.28	34.36	8.51	34.05	191	299	Average
5460	56.84	48.02	74	-17.16	34.36	8.51	34.05	191	299	Peak
5470	55.74	46.91	68.2	-12.46	34.37	8.51	34.05	191	299	Peak
5500	93.11	84.19			34.4	8.57	34.05	191	299	Average
5500	100.28	91.36			34.4	8.57	34.05	191	299	Peak
5725	55.56	46.4	68.2	-12.64	34.62	8.65	34.11	191	299	Peak
Antenna Polarity & Test Distance: Vertical at 3 m										
Frequency (MHz)	Emissino Level (dBuV/m)	Read Level (dBuV)	Limit (dBuV/m)	Margin (dB)	Antenna Factor (dB/m)	Cable Loss (dB)	Preamp Factor (dB)	Antenna Height (cm)	Table Angle (Degree)	Remark
5454	42.57	33.75	54	-11.43	34.36	8.51	34.05	124	122	Average
5454	56.59	47.77	74	-17.41	34.36	8.51	34.05	124	122	Peak
5470	55.51	46.68	68.2	-12.69	34.37	8.51	34.05	124	122	Peak
5500	91.34	82.42			34.4	8.57	34.05	124	122	Average
5500	98.51	89.59			34.4	8.57	34.05	124	122	Peak
5725	54.69	45.53	68.2	-13.51	34.62	8.65	34.11	124	122	Peak

Remarks:

- Emission Level = Read Level + Antenna Factor + Cable Loss - Preamp Factor
Margin value = Emission level – Limit value
- 5500 MHz: Fundamental Frequency
- 5470 MHz & 5725 MHz: Out of Restricted Band



EUT Test Condition		Measurement Detail	
Channel	Channel 116	Frequency Range	1 GHz ~ 40 GHz
Input Power	120 Vac, 60 Hz	Detector Function	Peak (PK) Average (AV)
Environmental Conditions	25 deg. C, 65 % RH	Tested By	Karl Lee

Antenna Polarity & Test Distance: Horizontal at 3 m										
Frequency (MHz)	Emission Level (dBuV/m)	Read Level (dBuV)	Limit (dBuV/m)	Margin (dB)	Antenna Factor (dB/m)	Cable Loss (dB)	Preamp Factor (dB)	Antenna Height (cm)	Table Angle (Degree)	Remark
5380	42.36	33.68	54	-11.64	34.31	8.41	34.04	188	292	Average
5380	56.86	48.18	74	-17.14	34.31	8.41	34.04	188	292	Peak
5470	57.27	48.44	68.2	-10.93	34.37	8.51	34.05	188	292	Peak
5580	93.87	84.88			34.47	8.6	34.08	188	292	Average
5580	100.83	91.84			34.47	8.6	34.08	188	292	Peak
5725	56.35	47.19	68.2	-11.85	34.62	8.65	34.11	188	292	Peak

Antenna Polarity & Test Distance: Vertical at 3 m										
Frequency (MHz)	Emission Level (dBuV/m)	Read Level (dBuV)	Limit (dBuV/m)	Margin (dB)	Antenna Factor (dB/m)	Cable Loss (dB)	Preamp Factor (dB)	Antenna Height (cm)	Table Angle (Degree)	Remark
5448	42.61	33.78	54	-11.39	34.36	8.51	34.04	104	122	Average
5448	56.83	48	74	-17.17	34.36	8.51	34.04	104	122	Peak
5470	54.73	45.9	68.2	-13.47	34.37	8.51	34.05	104	122	Peak
5580	91.18	82.19			34.47	8.6	34.08	104	122	Average
5580	98.11	89.12			34.47	8.6	34.08	104	122	Peak
5725	55.78	46.62	68.2	-12.42	34.62	8.65	34.11	104	122	Peak

Remarks:

- Emission Level = Read Level + Antenna Factor + Cable Loss - Preamp Factor
Margin value = Emission level – Limit value
- 5580 MHz: Fundamental Frequency
- 5470 MHz & 5725 MHz: Out of Restricted Band

EUT Test Condition		Measurement Detail	
Channel	Channel 140	Frequency Range	1 GHz ~ 40 GHz
Input Power	120 Vac, 60 Hz	Detector Function	Peak (PK) Average (AV)
Environmental Conditions	25 deg. C, 65 % RH	Tested By	Karl Lee

Antenna Polarity & Test Distance: Horizontal at 3 m										
Frequency (MHz)	Emission Level (dBuV/m)	Read Level (dBuV)	Limit (dBuV/m)	Margin (dB)	Antenna Factor (dB/m)	Cable Loss (dB)	Preamp Factor (dB)	Antenna Height (cm)	Table Angle (Degree)	Remark
5406	42.21	33.49	54	-11.79	34.32	8.44	34.04	101	297	Average
5406	56.83	48.11	74	-17.17	34.32	8.44	34.04	101	297	Peak
5470	56.73	47.9	68.2	-11.47	34.37	8.51	34.05	101	297	Peak
5700	93.03	83.9			34.59	8.64	34.1	101	297	Average
5700	100.13	91			34.59	8.64	34.1	101	297	Peak
5725	54.87	45.71	68.2	-13.33	34.62	8.65	34.11	101	297	Peak
Antenna Polarity & Test Distance: Vertical at 3 m										
Frequency (MHz)	Emission Level (dBuV/m)	Read Level (dBuV)	Limit (dBuV/m)	Margin (dB)	Antenna Factor (dB/m)	Cable Loss (dB)	Preamp Factor (dB)	Antenna Height (cm)	Table Angle (Degree)	Remark
5414	42.33	33.6	54	-11.67	34.33	8.44	34.04	191	114	Average
5414	56.66	47.93	74	-17.34	34.33	8.44	34.04	191	114	Peak
5470	56.88	48.05	68.2	-11.32	34.37	8.51	34.05	191	114	Peak
5700	91.63	82.5			34.59	8.64	34.1	191	114	Average
5700	98.03	88.9			34.59	8.64	34.1	191	114	Peak
5725	55.42	46.26	68.2	-12.78	34.62	8.65	34.11	191	114	Peak

Remarks:

- Emission Level = Read Level + Antenna Factor + Cable Loss - Preamp Factor
Margin value = Emission level – Limit value
- 5700 MHz: Fundamental Frequency
- 5470 MHz & 5725 MHz: Out of Restricted Band

EUT Test Condition		Measurement Detail	
Channel	Channel 149	Frequency Range	1 GHz ~ 40 GHz
Input Power	120 Vac, 60 Hz	Detector Function	Peak (PK) Average (AV)
Environmental Conditions	25 deg. C, 65 % RH	Tested By	Karl Lee

Antenna Polarity & Test Distance: Horizontal at 3 m										
Frequency (MHz)	Emission Level (dBuV/m)	Read Level (dBuV)	Limit (dBuV/m)	Margin (dB)	Antenna Factor (dB/m)	Cable Loss (dB)	Preamp Factor (dB)	Antenna Height (cm)	Table Angle (Degree)	Remark
*5712	56.53	47.38	68.2	-11.67	34.61	8.65	34.11	210	188	Peak
*5724	55.54	46.38	78.2	-22.66	34.62	8.65	34.11	210	188	Peak
5745	83.87	74.68			34.64	8.66	34.11	210	188	Average
5745	91.13	81.94			34.64	8.66	34.11	210	188	Peak
*5852	57.78	48.48	78.2	-20.42	34.74	8.7	34.14	210	188	Peak
*5862	56.75	47.42	68.2	-11.45	34.76	8.71	34.14	210	188	Peak
Antenna Polarity & Test Distance: Vertical at 3 m										
Frequency (MHz)	Emission Level (dBuV/m)	Read Level (dBuV)	Limit (dBuV/m)	Margin (dB)	Antenna Factor (dB/m)	Cable Loss (dB)	Preamp Factor (dB)	Antenna Height (cm)	Table Angle (Degree)	Remark
*5712	56.97	47.82	68.2	-11.23	34.61	8.65	34.11	109	1	Peak
*5720	57.36	48.2	78.2	-20.84	34.62	8.65	34.11	109	1	Peak
5745	87.73	78.54			34.64	8.66	34.11	109	1	Average
5745	94.95	85.76			34.64	8.66	34.11	109	1	Peak
*5860	57.3	47.98	78.2	-20.9	34.76	8.7	34.14	109	1	Peak
*5868	56.88	47.55	68.2	-11.32	34.76	8.71	34.14	109	1	Peak

Remarks:

- Emission Level = Read Level + Antenna Factor + Cable Loss - Preamp Factor
Margin value = Emission level – Limit value
- 5745 MHz: Fundamental Frequency
- *: Out of Restricted Band

EUT Test Condition		Measurement Detail	
Channel	Channel 157	Frequency Range	1 GHz ~ 40 GHz
Input Power	120 Vac, 60 Hz	Detector Function	Peak (PK) Average (AV)
Environmental Conditions	25 deg. C, 65 % RH	Tested By	Karl Lee

Antenna Polarity & Test Distance: Horizontal at 3 m										
Frequency (MHz)	Emission Level (dBuV/m)	Read Level (dBuV)	Limit (dBuV/m)	Margin (dB)	Antenna Factor (dB/m)	Cable Loss (dB)	Preamp Factor (dB)	Antenna Height (cm)	Table Angle (Degree)	Remark
*5714	56.49	47.34	68.2	-11.71	34.61	8.65	34.11	199	188	Peak
*5720	56.5	47.34	78.2	-21.7	34.62	8.65	34.11	199	188	Peak
5785	83.13	73.9			34.68	8.68	34.13	199	188	Average
5785	91.29	82.06			34.68	8.68	34.13	199	188	Peak
*5854	56.64	47.32	78.2	-21.56	34.76	8.7	34.14	199	188	Peak
*5864	56.42	47.09	68.2	-11.78	34.76	8.71	34.14	199	188	Peak
Antenna Polarity & Test Distance: Vertical at 3 m										
Frequency (MHz)	Emission Level (dBuV/m)	Read Level (dBuV)	Limit (dBuV/m)	Margin (dB)	Antenna Factor (dB/m)	Cable Loss (dB)	Preamp Factor (dB)	Antenna Height (cm)	Table Angle (Degree)	Remark
*5712	56.66	47.51	68.2	-11.54	34.61	8.65	34.11	103	13	Peak
*5724	57.36	48.2	78.2	-20.84	34.62	8.65	34.11	103	13	Peak
5785	86.74	77.51			34.68	8.68	34.13	103	13	Average
5785	94.71	85.48			34.68	8.68	34.13	103	13	Peak
*5852	57.22	47.92	78.2	-20.98	34.74	8.7	34.14	103	13	Peak
*5864	56.42	47.09	68.2	-11.78	34.76	8.71	34.14	103	13	Peak

Remarks:

- Emission Level = Read Level + Antenna Factor + Cable Loss - Preamp Factor
Margin value = Emission level – Limit value
- 5785 MHz: Fundamental Frequency
- *: Out of Restricted Band

EUT Test Condition		Measurement Detail	
Channel	Channel 165	Frequency Range	1 GHz ~ 40 GHz
Input Power	120 Vac, 60 Hz	Detector Function	Peak (PK) Average (AV)
Environmental Conditions	25 deg. C, 65 % RH	Tested By	Karl Lee

Antenna Polarity & Test Distance: Horizontal at 3 m										
Frequency (MHz)	Emission Level (dBuV/m)	Read Level (dBuV)	Limit (dBuV/m)	Margin (dB)	Antenna Factor (dB/m)	Cable Loss (dB)	Preamp Factor (dB)	Antenna Height (cm)	Table Angle (Degree)	Remark
*5708	57.41	48.26	68.2	-10.79	34.61	8.65	34.11	199	188	Peak
*5720	56.75	47.59	78.2	-21.45	34.62	8.65	34.11	199	188	Peak
5825	82.54	73.25			34.73	8.69	34.13	199	188	Average
5825	90.66	81.37			34.73	8.69	34.13	199	188	Peak
*5854	56.52	47.2	78.2	-21.68	34.76	8.7	34.14	199	188	Peak
*5870	56.51	47.18	68.2	-11.69	34.76	8.71	34.14	199	188	Peak
Antenna Polarity & Test Distance: Vertical at 3 m										
Frequency (MHz)	Emission Level (dBuV/m)	Read Level (dBuV)	Limit (dBuV/m)	Margin (dB)	Antenna Factor (dB/m)	Cable Loss (dB)	Preamp Factor (dB)	Antenna Height (cm)	Table Angle (Degree)	Remark
*5712	56.88	47.73	68.2	-11.32	34.61	8.65	34.11	108	2	Peak
*5716	56.49	47.34	78.2	-21.71	34.61	8.65	34.11	108	2	Peak
5825	87.08	77.79			34.73	8.69	34.13	108	2	Average
5825	94.72	85.43			34.73	8.69	34.13	108	2	Peak
*5856	55.99	46.67	78.2	-22.21	34.76	8.7	34.14	108	2	Peak
*5868	56.22	46.89	68.2	-11.98	34.76	8.71	34.14	108	2	Peak

Remarks:

- Emission Level = Read Level + Antenna Factor + Cable Loss - Preamp Factor
Margin value = Emission level – Limit value
- 5825 MHz: Fundamental Frequency
- *: Out of Restricted Band

802.11n (HT20)

EUT Test Condition		Measurement Detail	
Channel	Channel 36	Frequency Range	1 GHz ~ 40 GHz
Input Power	120 Vac, 60 Hz	Detector Function	Peak (PK) Average (AV)
Environmental Conditions	25 deg. C, 65 % RH	Tested By	Karl Lee

Antenna Polarity & Test Distance: Horizontal at 3 m

Frequency (MHz)	Emission Level (dBuV/m)	Read Level (dBuV)	Limit (dBuV/m)	Margin (dB)	Antenna Factor (dB/m)	Cable Loss (dB)	Preamp Factor (dB)	Antenna Height (cm)	Table Angle (Degree)	Remark
5128	44.68	36.46	54	-9.32	34.11	8.1	33.99	105	298	Average
5128	56.45	48.23	74	-17.55	34.11	8.1	33.99	105	298	Peak
5180	93.14	84.83			34.15	8.16	34	105	298	Average
5180	100.6	92.29			34.15	8.16	34	105	298	Peak
5442	42.37	33.58	54	-11.63	34.35	8.48	34.04	105	298	Average
5442	57.4	48.61	74	-16.6	34.35	8.48	34.04	105	298	Peak

Antenna Polarity & Test Distance: Vertical at 3 m

Frequency (MHz)	Emission Level (dBuV/m)	Read Level (dBuV)	Limit (dBuV/m)	Margin (dB)	Antenna Factor (dB/m)	Cable Loss (dB)	Preamp Factor (dB)	Antenna Height (cm)	Table Angle (Degree)	Remark
5036	42.97	34.91	54	-11.03	34.03	8	33.97	179	278	Average
5036	57.28	49.22	74	-16.72	34.03	8	33.97	179	278	Peak
5180	90.49	82.18			34.15	8.16	34	179	278	Average
5180	98.7	90.39			34.15	8.16	34	179	278	Peak
5434	41.99	33.2	54	-12.01	34.35	8.48	34.04	179	278	Average
5434	57.65	48.86	74	-16.35	34.35	8.48	34.04	179	278	Peak

Remarks:

- Emission Level = Read Level + Antenna Factor + Cable Loss - Preamp Factor
Margin value = Emission level – Limit value
- 5180 MHz: Fundamental Frequency



EUT Test Condition		Measurement Detail	
Channel	Channel 44	Frequency Range	1 GHz ~ 40 GHz
Input Power	120 Vac, 60 Hz	Detector Function	Peak (PK) Average (AV)
Environmental Conditions	25 deg. C, 65 % RH	Tested By	Karl Lee

Antenna Polarity & Test Distance: Horizontal at 3 m										
Frequency (MHz)	Emission Level (dBuV/m)	Read Level (dBuV)	Limit (dBuV/m)	Margin (dB)	Antenna Factor (dB/m)	Cable Loss (dB)	Preamp Factor (dB)	Antenna Height (cm)	Table Angle (Degree)	Remark
5058	42.86	34.76	54	-11.14	34.05	8.03	33.98	104	298	Average
5058	56.14	48.04	74	-17.86	34.05	8.03	33.98	104	298	Peak
5220	93.36	84.97			34.17	8.22	34	104	298	Average
5220	100.31	91.92			34.17	8.22	34	104	298	Peak
5384	42.28	33.6	54	-11.72	34.31	8.41	34.04	104	298	Average
5384	57.04	48.36	74	-16.96	34.31	8.41	34.04	104	298	Peak

Antenna Polarity & Test Distance: Vertical at 3 m										
Frequency (MHz)	Emission Level (dBuV/m)	Read Level (dBuV)	Limit (dBuV/m)	Margin (dB)	Antenna Factor (dB/m)	Cable Loss (dB)	Preamp Factor (dB)	Antenna Height (cm)	Table Angle (Degree)	Remark
5070	42.25	34.15	54	-11.75	34.05	8.03	33.98	184	276	Average
5070	56.4	48.3	74	-17.6	34.05	8.03	33.98	184	276	Peak
5220	90.09	81.7			34.17	8.22	34	184	276	Average
5220	98.21	89.82			34.17	8.22	34	184	276	Peak
5438	42.46	33.67	54	-11.54	34.35	8.48	34.04	184	276	Average
5438	57.01	48.22	74	-16.99	34.35	8.48	34.04	184	276	Peak

Remarks:

- Emission Level = Read Level + Antenna Factor + Cable Loss - Preamp Factor
Margin value = Emission level – Limit value
- 5220 MHz: Fundamental Frequency

EUT Test Condition		Measurement Detail	
Channel	Channel 48	Frequency Range	1 GHz ~ 40 GHz
Input Power	120 Vac, 60 Hz	Detector Function	Peak (PK) Average (AV)
Environmental Conditions	25 deg. C, 65 % RH	Tested By	Karl Lee

Antenna Polarity & Test Distance: Horizontal at 3 m										
Frequency (MHz)	Emission Level (dBuV/m)	Read Level (dBuV)	Limit (dBuV/m)	Margin (dB)	Antenna Factor (dB/m)	Cable Loss (dB)	Preamp Factor (dB)	Antenna Height (cm)	Table Angle (Degree)	Remark
5116	42.54	34.34	54	-11.46	34.09	8.1	33.99	103	303	Average
5116	55.41	47.21	74	-18.59	34.09	8.1	33.99	103	303	Peak
5240	93.58	85.14			34.19	8.26	34.01	103	303	Average
5240	100.46	92.02			34.19	8.26	34.01	103	303	Peak
5460	41.93	33.11	54	-12.07	34.36	8.51	34.05	103	303	Average
5460	56.37	47.55	74	-17.63	34.36	8.51	34.05	103	303	Peak
Antenna Polarity & Test Distance: Vertical at 3 m										
Frequency (MHz)	Emission Level (dBuV/m)	Read Level (dBuV)	Limit (dBuV/m)	Margin (dB)	Antenna Factor (dB/m)	Cable Loss (dB)	Preamp Factor (dB)	Antenna Height (cm)	Table Angle (Degree)	Remark
5148	42.16	33.91	54	-11.84	34.12	8.13	34	152	277	Average
5148	56.08	47.83	74	-17.92	34.12	8.13	34	152	277	Peak
5240	90.93	82.49			34.19	8.26	34.01	152	277	Average
5240	98.81	90.37			34.19	8.26	34.01	152	277	Peak
5438	42.3	33.51	54	-11.7	34.35	8.48	34.04	152	277	Average
5438	57.21	48.42	74	-16.79	34.35	8.48	34.04	152	277	Peak

Remarks:

- Emission Level = Read Level + Antenna Factor + Cable Loss - Preamp Factor
Margin value = Emission level – Limit value
- 5240 MHz: Fundamental Frequency



EUT Test Condition		Measurement Detail	
Channel	Channel 52	Frequency Range	1 GHz ~ 40 GHz
Input Power	120 Vac, 60 Hz	Detector Function	Peak (PK) Average (AV)
Environmental Conditions	25 deg. C, 65 % RH	Tested By	Karl Lee

Antenna Polarity & Test Distance: Horizontal at 3 m										
Frequency (MHz)	Emission Level (dBuV/m)	Read Level (dBuV)	Limit (dBuV/m)	Margin (dB)	Antenna Factor (dB/m)	Cable Loss (dB)	Preamp Factor (dB)	Antenna Height (cm)	Table Angle (Degree)	Remark
5108	41.64	33.44	54	-12.36	34.09	8.1	33.99	128	164	Average
5108	55.34	47.14	74	-18.66	34.09	8.1	33.99	128	164	Peak
5260	87.82	79.36			34.21	8.26	34.01	128	164	Average
5260	94.86	86.4			34.21	8.26	34.01	128	164	Peak
5446	42.32	33.49	54	-11.68	34.36	8.51	34.04	128	164	Average
5446	57.15	48.32	74	-16.85	34.36	8.51	34.04	128	164	Peak

Antenna Polarity & Test Distance: Vertical at 3 m										
Frequency (MHz)	Emission Level (dBuV/m)	Read Level (dBuV)	Limit (dBuV/m)	Margin (dB)	Antenna Factor (dB/m)	Cable Loss (dB)	Preamp Factor (dB)	Antenna Height (cm)	Table Angle (Degree)	Remark
5090	41.66	33.49	54	-12.34	34.08	8.07	33.98	101	357	Average
5090	56.88	48.71	74	-17.12	34.08	8.07	33.98	101	357	Peak
5260	93.47	85.01			34.21	8.26	34.01	101	357	Average
5260	100.64	92.18			34.21	8.26	34.01	101	357	Peak
5438	42.33	33.54	54	-11.67	34.35	8.48	34.04	101	357	Average
5438	57.01	48.22	74	-16.99	34.35	8.48	34.04	101	357	Peak

Remarks:

1. Emission Level = Read Level + Antenna Factor + Cable Loss - Preamp Factor
Margin value = Emission level – Limit value
2. 5260 MHz: Fundamental Frequency



EUT Test Condition		Measurement Detail	
Channel	Channel 60	Frequency Range	1 GHz ~ 40 GHz
Input Power	120 Vac, 60 Hz	Detector Function	Peak (PK) Average (AV)
Environmental Conditions	25 deg. C, 65 % RH	Tested By	Karl Lee

Antenna Polarity & Test Distance: Horizontal at 3 m										
Frequency (MHz)	Emission Level (dBuV/m)	Read Level (dBuV)	Limit (dBuV/m)	Margin (dB)	Antenna Factor (dB/m)	Cable Loss (dB)	Preamp Factor (dB)	Antenna Height (cm)	Table Angle (Degree)	Remark
5126	41.7	33.48	54	-12.3	34.11	8.1	33.99	141	172	Average
5126	56.04	47.82	74	-17.96	34.11	8.1	33.99	141	172	Peak
5300	87.56	79.02			34.24	8.32	34.02	141	172	Average
5300	94.53	85.99			34.24	8.32	34.02	141	172	Peak
5440	42.32	33.53	54	-11.68	34.35	8.48	34.04	141	172	Average
5440	56.7	47.91	74	-17.3	34.35	8.48	34.04	141	172	Peak
Antenna Polarity & Test Distance: Vertical at 3 m										
Frequency (MHz)	Emission Level (dBuV/m)	Read Level (dBuV)	Limit (dBuV/m)	Margin (dB)	Antenna Factor (dB/m)	Cable Loss (dB)	Preamp Factor (dB)	Antenna Height (cm)	Table Angle (Degree)	Remark
5094	41.71	33.55	54	-12.29	34.08	8.07	33.99	100	358	Average
5094	56.34	48.18	74	-17.66	34.08	8.07	33.99	100	358	Peak
5300	93.25	84.71			34.24	8.32	34.02	100	358	Average
5300	100.16	91.62			34.24	8.32	34.02	100	358	Peak
5450	42.43	33.61	54	-11.57	34.36	8.51	34.05	100	358	Average
5450	57.28	48.46	74	-16.72	34.36	8.51	34.05	100	358	Peak

Remarks:

- Emission Level = Read Level + Antenna Factor + Cable Loss - Preamp Factor
Margin value = Emission level – Limit value
- 5300 MHz: Fundamental Frequency



EUT Test Condition		Measurement Detail	
Channel	Channel 64	Frequency Range	1 GHz ~ 40 GHz
Input Power	120 Vac, 60 Hz	Detector Function	Peak (PK) Average (AV)
Environmental Conditions	25 deg. C, 65 % RH	Tested By	Karl Lee

Antenna Polarity & Test Distance: Horizontal at 3 m										
Frequency (MHz)	Emission Level (dBuV/m)	Read Level (dBuV)	Limit (dBuV/m)	Margin (dB)	Antenna Factor (dB/m)	Cable Loss (dB)	Preamp Factor (dB)	Antenna Height (cm)	Table Angle (Degree)	Remark
5096	41.8	33.64	54	-12.2	34.08	8.07	33.99	141	172	Average
5096	55.77	47.61	74	-18.23	34.08	8.07	33.99	141	172	Peak
5320	87.05	78.47			34.25	8.35	34.02	141	172	Average
5320	94.06	85.48			34.25	8.35	34.02	141	172	Peak
5460	42.52	33.7	54	-11.48	34.36	8.51	34.05	141	172	Average
5460	57.49	48.67	74	-16.51	34.36	8.51	34.05	141	172	Peak
Antenna Polarity & Test Distance: Vertical at 3 m										
Frequency (MHz)	Emission Level (dBuV/m)	Read Level (dBuV)	Limit (dBuV/m)	Margin (dB)	Antenna Factor (dB/m)	Cable Loss (dB)	Preamp Factor (dB)	Antenna Height (cm)	Table Angle (Degree)	Remark
5088	41.58	33.42	54	-12.42	34.07	8.07	33.98	100	358	Average
5088	56.63	48.47	74	-17.37	34.07	8.07	33.98	100	358	Peak
5320	93.76	85.18			34.25	8.35	34.02	100	358	Average
5320	100.61	92.03			34.25	8.35	34.02	100	358	Peak
5436	42.62	33.83	54	-11.38	34.35	8.48	34.04	100	358	Average
5436	57.45	48.66	74	-16.55	34.35	8.48	34.04	100	358	Peak

Remarks:

- Emission Level = Read Level + Antenna Factor + Cable Loss - Preamp Factor
Margin value = Emission level – Limit value
- 5320 MHz: Fundamental Frequency

EUT Test Condition		Measurement Detail	
Channel	Channel 100	Frequency Range	1 GHz ~ 40 GHz
Input Power	120 Vac, 60 Hz	Detector Function	Peak (PK) Average (AV)
Environmental Conditions	25 deg. C, 65 % RH	Tested By	Karl Lee

Antenna Polarity & Test Distance: Horizontal at 3 m										
Frequency (MHz)	Emission Level (dBuV/m)	Read Level (dBuV)	Limit (dBuV/m)	Margin (dB)	Antenna Factor (dB/m)	Cable Loss (dB)	Preamp Factor (dB)	Antenna Height (cm)	Table Angle (Degree)	Remark
5444	42.69	33.9	54	-11.31	34.35	8.48	34.04	191	299	Average
5444	56.63	47.84	74	-17.37	34.35	8.48	34.04	191	299	Peak
5470	56.02	47.19	68.2	-12.18	34.37	8.51	34.05	191	299	Peak
5500	91.96	83.04			34.4	8.57	34.05	191	299	Average
5500	98.52	89.6			34.4	8.57	34.05	191	299	Peak
5725	56.36	47.2	68.2	-11.84	34.62	8.65	34.11	191	299	Peak
Antenna Polarity & Test Distance: Vertical at 3 m										
Frequency (MHz)	Emission Level (dBuV/m)	Read Level (dBuV)	Limit (dBuV/m)	Margin (dB)	Antenna Factor (dB/m)	Cable Loss (dB)	Preamp Factor (dB)	Antenna Height (cm)	Table Angle (Degree)	Remark
5422	42.67	33.9	54	-11.33	34.33	8.48	34.04	124	122	Average
5422	57.85	49.08	74	-16.15	34.33	8.48	34.04	124	122	Peak
5470	56.39	47.56	68.2	-11.81	34.37	8.51	34.05	124	122	Peak
5500	89.82	80.9			34.4	8.57	34.05	124	122	Average
5500	96.34	87.42			34.4	8.57	34.05	124	122	Peak
5725	56.36	47.2	68.2	-11.84	34.62	8.65	34.11	124	122	Peak

Remarks:

- Emission Level = Read Level + Antenna Factor + Cable Loss - Preamp Factor
Margin value = Emission level – Limit value
- 5500 MHz: Fundamental Frequency
- 5470 MHz & 5725 MHz: Out of Restricted Band

EUT Test Condition		Measurement Detail	
Channel	Channel 116	Frequency Range	1 GHz ~ 40 GHz
Input Power	120 Vac, 60 Hz	Detector Function	Peak (PK) Average (AV)
Environmental Conditions	25 deg. C, 65 % RH	Tested By	Karl Lee

Antenna Polarity & Test Distance: Horizontal at 3 m										
Frequency (MHz)	Emission Level (dBuV/m)	Read Level (dBuV)	Limit (dBuV/m)	Margin (dB)	Antenna Factor (dB/m)	Cable Loss (dB)	Preamp Factor (dB)	Antenna Height (cm)	Table Angle (Degree)	Remark
5454	42.88	34.06	54	-11.12	34.36	8.51	34.05	188	292	Average
5454	57.1	48.28	74	-16.9	34.36	8.51	34.05	188	292	Peak
5470	55.42	46.59	68.2	-12.78	34.37	8.51	34.05	188	292	Peak
5580	91.46	82.47			34.47	8.6	34.08	188	292	Average
5580	98.66	89.67			34.47	8.6	34.08	188	292	Peak
5725	55.93	46.77	68.2	-12.27	34.62	8.65	34.11	188	292	Peak
Antenna Polarity & Test Distance: Vertical at 3 m										
Frequency (MHz)	Emission Level (dBuV/m)	Read Level (dBuV)	Limit (dBuV/m)	Margin (dB)	Antenna Factor (dB/m)	Cable Loss (dB)	Preamp Factor (dB)	Antenna Height (cm)	Table Angle (Degree)	Remark
5456	42.51	33.69	54	-11.49	34.36	8.51	34.05	104	153	Average
5456	56.36	47.54	74	-17.64	34.36	8.51	34.05	104	153	Peak
5470	56.09	47.26	68.2	-12.11	34.37	8.51	34.05	104	153	Peak
5580	89.65	80.66			34.47	8.6	34.08	104	153	Average
5580	96.31	87.32			34.47	8.6	34.08	104	153	Peak
5725	55.35	46.19	68.2	-12.85	34.62	8.65	34.11	104	153	Peak

Remarks:

- Emission Level = Read Level + Antenna Factor + Cable Loss - Preamp Factor
Margin value = Emission level – Limit value
- 5580 MHz: Fundamental Frequency
- 5470 MHz & 5725 MHz: Out of Restricted Band



EUT Test Condition		Measurement Detail	
Channel	Channel 140	Frequency Range	1 GHz ~ 40 GHz
Input Power	120 Vac, 60 Hz	Detector Function	Peak (PK) Average (AV)
Environmental Conditions	25 deg. C, 65 % RH	Tested By	Karl Lee

Antenna Polarity & Test Distance: Horizontal at 3 m										
Frequency (MHz)	Emission Level (dBuV/m)	Read Level (dBuV)	Limit (dBuV/m)	Margin (dB)	Antenna Factor (dB/m)	Cable Loss (dB)	Preamp Factor (dB)	Antenna Height (cm)	Table Angle (Degree)	Remark
5412	42.19	33.46	54	-11.81	34.33	8.44	34.04	101	297	Average
5412	57.04	48.31	74	-16.96	34.33	8.44	34.04	101	297	Peak
5470	55.28	46.45	68.2	-12.92	34.37	8.51	34.05	101	297	Peak
5700	91.04	81.91			34.59	8.64	34.1	101	297	Average
5700	98.55	89.42			34.59	8.64	34.1	101	297	Peak
5725	56.38	47.22	68.2	-11.82	34.62	8.65	34.11	101	297	Peak
Antenna Polarity & Test Distance: Vertical at 3 m										
Frequency (MHz)	Emission Level (dBuV/m)	Read Level (dBuV)	Limit (dBuV/m)	Margin (dB)	Antenna Factor (dB/m)	Cable Loss (dB)	Preamp Factor (dB)	Antenna Height (cm)	Table Angle (Degree)	Remark
5432	42.53	33.74	54	-11.47	34.35	8.48	34.04	191	114	Average
5432	57.1	48.31	74	-16.9	34.35	8.48	34.04	191	114	Peak
5470	56.62	47.79	68.2	-11.58	34.37	8.51	34.05	191	114	Peak
5700	89.33	80.2			34.59	8.64	34.1	191	114	Average
5700	96.31	87.18			34.59	8.64	34.1	191	114	Peak
5725	55.72	46.56	68.2	-12.48	34.62	8.65	34.11	191	114	Peak

Remarks:

- Emission Level = Read Level + Antenna Factor + Cable Loss - Preamp Factor
Margin value = Emission level – Limit value
- 5700 MHz: Fundamental Frequency
- 5470 MHz & 5725 MHz: Out of Restricted Band

EUT Test Condition		Measurement Detail	
Channel	Channel 149	Frequency Range	1 GHz ~ 40 GHz
Input Power	120 Vac, 60 Hz	Detector Function	Peak (PK) Average (AV)
Environmental Conditions	25 deg. C, 65 % RH	Tested By	Karl Lee

Antenna Polarity & Test Distance: Horizontal at 3 m										
Frequency (MHz)	Emissino Level (dBuV/m)	Read Level (dBuV)	Limit (dBuV/m)	Margin (dB)	Antenna Factor (dB/m)	Cable Loss (dB)	Preamp Factor (dB)	Antenna Height (cm)	Table Angle (Degree)	Remark
*5708	56.73	47.58	68.2	-11.47	34.61	8.65	34.11	210	188	Peak
*5724	55.77	46.61	78.2	-22.43	34.62	8.65	34.11	210	188	Peak
5745	83.42	74.23			34.64	8.66	34.11	210	188	Average
5745	90.33	81.14			34.64	8.66	34.11	210	188	Peak
*5860	56.86	47.54	78.2	-21.34	34.76	8.7	34.14	210	188	Peak
*5870	55.41	46.08	68.2	-12.79	34.76	8.71	34.14	210	188	Peak
Antenna Polarity & Test Distance: Vertical at 3 m										
Frequency (MHz)	Emissino Level (dBuV/m)	Read Level (dBuV)	Limit (dBuV/m)	Margin (dB)	Antenna Factor (dB/m)	Cable Loss (dB)	Preamp Factor (dB)	Antenna Height (cm)	Table Angle (Degree)	Remark
*5708	56.6	47.45	68.2	-11.6	34.61	8.65	34.11	109	1	Peak
*5716	56.67	47.52	78.2	-21.53	34.61	8.65	34.11	109	1	Peak
5745	87.2	78.01			34.64	8.66	34.11	109	1	Average
5745	94.79	85.6			34.64	8.66	34.11	109	1	Peak
*5852	57.25	47.95	78.2	-20.95	34.74	8.7	34.14	109	1	Peak
*5866	57.14	47.81	68.2	-11.06	34.76	8.71	34.14	109	1	Peak

Remarks:

- Emission Level = Read Level + Antenna Factor + Cable Loss - Preamp Factor
Margin value = Emission level – Limit value
- 5745 MHz: Fundamental Frequency
- *: Out of Restricted Band



EUT Test Condition		Measurement Detail	
Channel	Channel 157	Frequency Range	1 GHz ~ 40 GHz
Input Power	120 Vac, 60 Hz	Detector Function	Peak (PK) Average (AV)
Environmental Conditions	25 deg. C, 65 % RH	Tested By	Karl Lee

Antenna Polarity & Test Distance: Horizontal at 3 m										
Frequency (MHz)	Emission Level (dBuV/m)	Read Level (dBuV)	Limit (dBuV/m)	Margin (dB)	Antenna Factor (dB/m)	Cable Loss (dB)	Preamp Factor (dB)	Antenna Height (cm)	Table Angle (Degree)	Remark
*5714	57.45	48.3	68.2	-10.75	34.61	8.65	34.11	199	188	Peak
*5722	56.82	47.66	78.2	-21.38	34.62	8.65	34.11	199	188	Peak
5785	82.93	73.7			34.68	8.68	34.13	199	188	Average
5785	90.87	81.64			34.68	8.68	34.13	199	188	Peak
*5852	57.23	47.93	78.2	-20.97	34.74	8.7	34.14	199	188	Peak
*5864	56.89	47.56	68.2	-11.31	34.76	8.71	34.14	199	188	Peak
Antenna Polarity & Test Distance: Vertical at 3 m										
Frequency (MHz)	Emission Level (dBuV/m)	Read Level (dBuV)	Limit (dBuV/m)	Margin (dB)	Antenna Factor (dB/m)	Cable Loss (dB)	Preamp Factor (dB)	Antenna Height (cm)	Table Angle (Degree)	Remark
*5710	57.08	47.93	68.2	-11.12	34.61	8.65	34.11	103	13	Peak
*5716	58.07	48.92	78.2	-20.13	34.61	8.65	34.11	103	13	Peak
5785	87.09	77.86			34.68	8.68	34.13	103	13	Average
5785	94.67	85.44			34.68	8.68	34.13	103	13	Peak
*5858	56.78	47.46	78.2	-21.42	34.76	8.7	34.14	103	13	Peak
*5868	57.87	48.54	68.2	-10.33	34.76	8.71	34.14	103	13	Peak

Remarks:

- Emission Level = Read Level + Antenna Factor + Cable Loss - Preamp Factor
Margin value = Emission level – Limit value
- 5785 MHz: Fundamental Frequency
- *: Out of Restricted Band



EUT Test Condition		Measurement Detail	
Channel	Channel 165	Frequency Range	1 GHz ~ 40 GHz
Input Power	120 Vac, 60 Hz	Detector Function	Peak (PK) Average (AV)
Environmental Conditions	25 deg. C, 65 % RH	Tested By	Karl Lee

Antenna Polarity & Test Distance: Horizontal at 3 m										
Frequency (MHz)	Emission Level (dBuV/m)	Read Level (dBuV)	Limit (dBuV/m)	Margin (dB)	Antenna Factor (dB/m)	Cable Loss (dB)	Preamp Factor (dB)	Antenna Height (cm)	Table Angle (Degree)	Remark
*5714	55.93	46.78	68.2	-12.27	34.61	8.65	34.11	199	188	Peak
*5718	55.75	46.59	78.2	-22.45	34.62	8.65	34.11	199	188	Peak
5825	82.89	73.6			34.73	8.69	34.13	199	188	Average
5825	90.07	80.78			34.73	8.69	34.13	199	188	Peak
*5856	56.61	47.29	78.2	-21.59	34.76	8.7	34.14	199	188	Peak
*5866	57	47.67	68.2	-11.2	34.76	8.71	34.14	199	188	Peak
Antenna Polarity & Test Distance: Vertical at 3 m										
Frequency (MHz)	Emission Level (dBuV/m)	Read Level (dBuV)	Limit (dBuV/m)	Margin (dB)	Antenna Factor (dB/m)	Cable Loss (dB)	Preamp Factor (dB)	Antenna Height (cm)	Table Angle (Degree)	Remark
*5710	56.39	47.24	68.2	-11.81	34.61	8.65	34.11	108	2	Peak
*5722	55.12	45.96	78.2	-23.08	34.62	8.65	34.11	108	2	Peak
5825	86.6	77.31			34.73	8.69	34.13	108	2	Average
5825	94.02	84.73			34.73	8.69	34.13	108	2	Peak
*5860	55.43	46.11	78.2	-22.77	34.76	8.7	34.14	108	2	Peak
*5862	55.8	46.47	68.2	-12.4	34.76	8.71	34.14	108	2	Peak

Remarks:

- Emission Level = Read Level + Antenna Factor + Cable Loss - Preamp Factor
Margin value = Emission level – Limit value
- 5825 MHz: Fundamental Frequency
- *: Out of Restricted Band

802.11n (HT40)

EUT Test Condition		Measurement Detail	
Channel	Channel 38	Frequency Range	1 GHz ~ 40 GHz
Input Power	120 Vac, 60 Hz	Detector Function	Peak (PK) Average (AV)
Environmental Conditions	25 deg. C, 65 % RH	Tested By	Karl Lee

Antenna Polarity & Test Distance: Horizontal at 3 m

Frequency (MHz)	Emission Level (dBuV/m)	Read Level (dBuV)	Limit (dBuV/m)	Margin (dB)	Antenna Factor (dB/m)	Cable Loss (dB)	Preamp Factor (dB)	Antenna Height (cm)	Table Angle (Degree)	Remark
5108	45.11	36.91	54	-8.89	34.09	8.1	33.99	105	298	Average
5108	57.18	48.98	74	-16.82	34.09	8.1	33.99	105	298	Peak
5190	90.26	81.92			34.15	8.19	34	105	298	Average
5190	98.38	90.04			34.15	8.19	34	105	298	Peak
5434	44.65	35.86	54	-9.35	34.35	8.48	34.04	105	298	Average
5434	57.83	49.04	74	-16.17	34.35	8.48	34.04	105	298	Peak

Antenna Polarity & Test Distance: Vertical at 3 m

Frequency (MHz)	Emission Level (dBuV/m)	Read Level (dBuV)	Limit (dBuV/m)	Margin (dB)	Antenna Factor (dB/m)	Cable Loss (dB)	Preamp Factor (dB)	Antenna Height (cm)	Table Angle (Degree)	Remark
5090	42.63	34.46	54	-11.37	34.08	8.07	33.98	188	278	Average
5090	56.02	47.85	74	-17.98	34.08	8.07	33.98	188	278	Peak
5190	88.92	80.58			34.15	8.19	34	188	278	Average
5190	96.6	88.26			34.15	8.19	34	188	278	Peak
5428	42.65	33.88	54	-11.35	34.33	8.48	34.04	188	278	Average
5428	56.81	48.04	74	-17.19	34.33	8.48	34.04	188	278	Peak

Remarks:

- Emission Level = Read Level + Antenna Factor + Cable Loss - Preamp Factor
Margin value = Emission level – Limit value
- 5190 MHz: Fundamental Frequency



EUT Test Condition		Measurement Detail	
Channel	Channel 46	Frequency Range	1 GHz ~ 40 GHz
Input Power	120 Vac, 60 Hz	Detector Function	Peak (PK) Average (AV)
Environmental Conditions	25 deg. C, 65 % RH	Tested By	Karl Lee

Antenna Polarity & Test Distance: Horizontal at 3 m										
Frequency (MHz)	Emission Level (dBuV/m)	Read Level (dBuV)	Limit (dBuV/m)	Margin (dB)	Antenna Factor (dB/m)	Cable Loss (dB)	Preamp Factor (dB)	Antenna Height (cm)	Table Angle (Degree)	Remark
5088	43.08	34.92	54	-10.92	34.07	8.07	33.98	104	303	Average
5088	56.56	48.4	74	-17.44	34.07	8.07	33.98	104	303	Peak
5230	90.46	82.06			34.19	8.22	34.01	104	303	Average
5230	98.7	90.3			34.19	8.22	34.01	104	303	Peak
5424	42.81	34.04	54	-11.19	34.33	8.48	34.04	104	303	Average
5424	57.24	48.47	74	-16.76	34.33	8.48	34.04	104	303	Peak
Antenna Polarity & Test Distance: Vertical at 3 m										
Frequency (MHz)	Emission Level (dBuV/m)	Read Level (dBuV)	Limit (dBuV/m)	Margin (dB)	Antenna Factor (dB/m)	Cable Loss (dB)	Preamp Factor (dB)	Antenna Height (cm)	Table Angle (Degree)	Remark
5050	42.29	34.23	54	-11.71	34.04	8	33.98	152	277	Average
5050	56.3	48.24	74	-17.7	34.04	8	33.98	152	277	Peak
5230	88.56	80.16			34.19	8.22	34.01	152	277	Average
5230	96.3	87.9			34.19	8.22	34.01	152	277	Peak
5442	42.84	34.05	54	-11.16	34.35	8.48	34.04	152	277	Average
5442	58.29	49.5	74	-15.71	34.35	8.48	34.04	152	277	Peak

Remarks:

- Emission Level = Read Level + Antenna Factor + Cable Loss - Preamp Factor
Margin value = Emission level – Limit value
- 5230 MHz: Fundamental Frequency



EUT Test Condition		Measurement Detail	
Channel	Channel 54	Frequency Range	1 GHz ~ 40 GHz
Input Power	120 Vac, 60 Hz	Detector Function	Peak (PK) Average (AV)
Environmental Conditions	25 deg. C, 65 % RH	Tested By	Karl Lee

Antenna Polarity & Test Distance: Horizontal at 3 m										
Frequency (MHz)	Emission Level (dBuV/m)	Read Level (dBuV)	Limit (dBuV/m)	Margin (dB)	Antenna Factor (dB/m)	Cable Loss (dB)	Preamp Factor (dB)	Antenna Height (cm)	Table Angle (Degree)	Remark
5120	42.74	34.54	54	-11.26	34.09	8.1	33.99	128	164	Average
5120	56.24	48.04	74	-17.76	34.09	8.1	33.99	128	164	Peak
5270	84.95	76.46			34.21	8.29	34.01	128	164	Average
5270	91.55	83.06			34.21	8.29	34.01	128	164	Peak
5426	43.36	34.59	54	-10.64	34.33	8.48	34.04	128	164	Average
5426	56.89	48.12	74	-17.11	34.33	8.48	34.04	128	164	Peak

Antenna Polarity & Test Distance: Vertical at 3 m										
Frequency (MHz)	Emission Level (dBuV/m)	Read Level (dBuV)	Limit (dBuV/m)	Margin (dB)	Antenna Factor (dB/m)	Cable Loss (dB)	Preamp Factor (dB)	Antenna Height (cm)	Table Angle (Degree)	Remark
5088	42.73	34.57	54	-11.27	34.07	8.07	33.98	194	357	Average
5088	56.74	48.58	74	-17.26	34.07	8.07	33.98	194	357	Peak
5270	90.04	81.55			34.21	8.29	34.01	194	357	Average
5270	97.17	88.68			34.21	8.29	34.01	194	357	Peak
5430	43.42	34.63	54	-10.58	34.35	8.48	34.04	194	357	Average
5430	57.36	48.57	74	-16.64	34.35	8.48	34.04	194	357	Peak

Remarks:

- Emission Level = Read Level + Antenna Factor + Cable Loss - Preamp Factor
Margin value = Emission level – Limit value
- 5270 MHz: Fundamental Frequency



EUT Test Condition		Measurement Detail	
Channel	Channel 62	Frequency Range	1 GHz ~ 40 GHz
Input Power	120 Vac, 60 Hz	Detector Function	Peak (PK) Average (AV)
Environmental Conditions	25 deg. C, 65 % RH	Tested By	Karl Lee

Antenna Polarity & Test Distance: Horizontal at 3 m										
Frequency (MHz)	Emission Level (dBuV/m)	Read Level (dBuV)	Limit (dBuV/m)	Margin (dB)	Antenna Factor (dB/m)	Cable Loss (dB)	Preamp Factor (dB)	Antenna Height (cm)	Table Angle (Degree)	Remark
5044	42.49	34.43	54	-11.51	34.04	8	33.98	128	171	Average
5044	56.45	48.39	74	-17.55	34.04	8	33.98	128	171	Peak
5310	84.46	75.91			34.25	8.32	34.02	128	171	Average
5310	91.76	83.21			34.25	8.32	34.02	128	171	Peak
5436	43.18	34.39	54	-10.82	34.35	8.48	34.04	128	171	Average
5436	57.16	48.37	74	-16.84	34.35	8.48	34.04	128	171	Peak

Antenna Polarity & Test Distance: Vertical at 3 m										
Frequency (MHz)	Emission Level (dBuV/m)	Read Level (dBuV)	Limit (dBuV/m)	Margin (dB)	Antenna Factor (dB/m)	Cable Loss (dB)	Preamp Factor (dB)	Antenna Height (cm)	Table Angle (Degree)	Remark
5120	42.48	34.28	54	-11.52	34.09	8.1	33.99	169	354	Average
5120	57.5	49.3	74	-16.5	34.09	8.1	33.99	169	354	Peak
5310	90.74	82.19			34.25	8.32	34.02	169	354	Average
5310	97.11	88.56			34.25	8.32	34.02	169	354	Peak
5450	43.02	34.2	54	-10.98	34.36	8.51	34.05	169	354	Average
5450	57.81	48.99	74	-16.19	34.36	8.51	34.05	169	354	Peak

Remarks:

- Emission Level = Read Level + Antenna Factor + Cable Loss - Preamp Factor
Margin value = Emission level – Limit value
- 5310 MHz: Fundamental Frequency



EUT Test Condition		Measurement Detail	
Channel	Channel 102	Frequency Range	1 GHz ~ 40 GHz
Input Power	120 Vac, 60 Hz	Detector Function	Peak (PK) Average (AV)
Environmental Conditions	25 deg. C, 65 % RH	Tested By	Karl Lee

Antenna Polarity & Test Distance: Horizontal at 3 m										
Frequency (MHz)	Emission Level (dBuV/m)	Read Level (dBuV)	Limit (dBuV/m)	Margin (dB)	Antenna Factor (dB/m)	Cable Loss (dB)	Preamp Factor (dB)	Antenna Height (cm)	Table Angle (Degree)	Remark
5456	42.89	34.07	54	-11.11	34.36	8.51	34.05	191	299	Average
5456	56.76	47.94	74	-17.24	34.36	8.51	34.05	191	299	Peak
5470	55.52	46.69	68.2	-12.68	34.37	8.51	34.05	191	299	Peak
5510	87.07	78.16			34.4	8.57	34.06	191	299	Average
5510	94.15	85.24			34.4	8.57	34.06	191	299	Peak
5725	54.48	45.32	68.2	-13.72	34.62	8.65	34.11	191	299	Peak

Antenna Polarity & Test Distance: Vertical at 3 m										
Frequency (MHz)	Emission Level (dBuV/m)	Read Level (dBuV)	Limit (dBuV/m)	Margin (dB)	Antenna Factor (dB/m)	Cable Loss (dB)	Preamp Factor (dB)	Antenna Height (cm)	Table Angle (Degree)	Remark
5446	42.77	33.94	54	-11.23	34.36	8.51	34.04	124	122	Average
5446	56.97	48.14	74	-17.03	34.36	8.51	34.04	124	122	Peak
5470	57.43	48.6	68.2	-10.77	34.37	8.51	34.05	124	122	Peak
5510	85.53	76.62			34.4	8.57	34.06	124	122	Average
5510	92.25	83.34			34.4	8.57	34.06	124	122	Peak
5725	55.34	46.18	68.2	-12.86	34.62	8.65	34.11	124	122	Peak

Remarks:

- Emission Level = Read Level + Antenna Factor + Cable Loss - Preamp Factor
Margin value = Emission level – Limit value
- 5510 MHz: Fundamental Frequency
- 5470 MHz & 5725 MHz: Out of Restricted Band



EUT Test Condition		Measurement Detail	
Channel	Channel 110	Frequency Range	1 GHz ~ 40 GHz
Input Power	120 Vac, 60 Hz	Detector Function	Peak (PK) Average (AV)
Environmental Conditions	25 deg. C, 65 % RH	Tested By	Karl Lee

Antenna Polarity & Test Distance: Horizontal at 3 m										
Frequency (MHz)	Emission Level (dBuV/m)	Read Level (dBuV)	Limit (dBuV/m)	Margin (dB)	Antenna Factor (dB/m)	Cable Loss (dB)	Preamp Factor (dB)	Antenna Height (cm)	Table Angle (Degree)	Remark
5424	43.03	34.26	54	-10.97	34.33	8.48	34.04	188	292	Average
5424	56.43	47.66	74	-17.57	34.33	8.48	34.04	188	292	Peak
5470	56.22	47.39	68.2	-11.98	34.37	8.51	34.05	188	292	Peak
5550	87.71	78.74			34.45	8.59	34.07	188	292	Average
5550	94.03	85.06			34.45	8.59	34.07	188	292	Peak
5725	55.94	46.78	68.2	-12.26	34.62	8.65	34.11	188	292	Peak
Antenna Polarity & Test Distance: Vertical at 3 m										
Frequency (MHz)	Emission Level (dBuV/m)	Read Level (dBuV)	Limit (dBuV/m)	Margin (dB)	Antenna Factor (dB/m)	Cable Loss (dB)	Preamp Factor (dB)	Antenna Height (cm)	Table Angle (Degree)	Remark
5436	43.08	34.29	54	-10.92	34.35	8.48	34.04	176	153	Average
5436	57.2	48.41	74	-16.8	34.35	8.48	34.04	176	153	Peak
5470	56.35	47.52	68.2	-11.85	34.37	8.51	34.05	176	153	Peak
5550	85.27	76.3			34.45	8.59	34.07	176	153	Average
5550	92	83.03			34.45	8.59	34.07	176	153	Peak
5725	55.13	45.97	68.2	-13.07	34.62	8.65	34.11	176	153	Peak

Remarks:

- Emission Level = Read Level + Antenna Factor + Cable Loss - Preamp Factor
Margin value = Emission level – Limit value
- 5550 MHz: Fundamental Frequency
- 5470 MHz & 5725 MHz: Out of Restricted Band

EUT Test Condition		Measurement Detail	
Channel	Channel 134	Frequency Range	1 GHz ~ 40 GHz
Input Power	120 Vac, 60 Hz	Detector Function	Peak (PK) Average (AV)
Environmental Conditions	25 deg. C, 65 % RH	Tested By	Karl Lee

Antenna Polarity & Test Distance: Horizontal at 3 m										
Frequency (MHz)	Emission Level (dBuV/m)	Read Level (dBuV)	Limit (dBuV/m)	Margin (dB)	Antenna Factor (dB/m)	Cable Loss (dB)	Preamp Factor (dB)	Antenna Height (cm)	Table Angle (Degree)	Remark
5426	43.25	34.48	54	-10.75	34.33	8.48	34.04	102	300	Average
5426	56.97	48.2	74	-17.03	34.33	8.48	34.04	102	300	Peak
5470	55.37	46.54	68.2	-12.83	34.37	8.51	34.05	102	300	Peak
5670	87.3	78.2			34.57	8.63	34.1	102	300	Average
5670	94.95	85.85			34.57	8.63	34.1	102	300	Peak
5725	56.61	47.45	68.2	-11.59	34.62	8.65	34.11	102	300	Peak
Antenna Polarity & Test Distance: Vertical at 3 m										
Frequency (MHz)	Emission Level (dBuV/m)	Read Level (dBuV)	Limit (dBuV/m)	Margin (dB)	Antenna Factor (dB/m)	Cable Loss (dB)	Preamp Factor (dB)	Antenna Height (cm)	Table Angle (Degree)	Remark
5420	43.2	34.43	54	-10.8	34.33	8.48	34.04	191	114	Average
5420	56.79	48.02	74	-17.21	34.33	8.48	34.04	191	114	Peak
5470	54.76	45.93	68.2	-13.44	34.37	8.51	34.05	191	114	Peak
5670	84.31	75.21			34.57	8.63	34.1	191	114	Average
5670	92.15	83.05			34.57	8.63	34.1	191	114	Peak
5725	55.16	46	68.2	-13.04	34.62	8.65	34.11	191	114	Peak

Remarks:

- Emission Level = Read Level + Antenna Factor + Cable Loss - Preamp Factor
Margin value = Emission level – Limit value
- 5670 MHz: Fundamental Frequency
- 5470 MHz & 5725 MHz: Out of Restricted Band



EUT Test Condition		Measurement Detail	
Channel	Channel 151	Frequency Range	1 GHz ~ 40 GHz
Input Power	120 Vac, 60 Hz	Detector Function	Peak (PK) Average (AV)
Environmental Conditions	25 deg. C, 65 % RH	Tested By	Karl Lee

Antenna Polarity & Test Distance: Horizontal at 3 m										
Frequency (MHz)	Emission Level (dBuV/m)	Read Level (dBuV)	Limit (dBuV/m)	Margin (dB)	Antenna Factor (dB/m)	Cable Loss (dB)	Preamp Factor (dB)	Antenna Height (cm)	Table Angle (Degree)	Remark
*5712	56.56	47.41	68.2	-11.64	34.61	8.65	34.11	210	188	Peak
*5720	56.45	47.29	78.2	-21.75	34.62	8.65	34.11	210	188	Peak
5755	79.36	70.15			34.66	8.66	34.11	210	188	Average
5755	87.67	78.46			34.66	8.66	34.11	210	188	Peak
*5852	56.81	47.51	78.2	-21.39	34.74	8.7	34.14	210	188	Peak
*5864	56.72	47.39	68.2	-11.48	34.76	8.71	34.14	210	188	Peak
Antenna Polarity & Test Distance: Vertical at 3 m										
Frequency (MHz)	Emission Level (dBuV/m)	Read Level (dBuV)	Limit (dBuV/m)	Margin (dB)	Antenna Factor (dB/m)	Cable Loss (dB)	Preamp Factor (dB)	Antenna Height (cm)	Table Angle (Degree)	Remark
*5712	56.78	47.63	68.2	-11.42	34.61	8.65	34.11	109	1	Peak
*5720	56.37	47.21	78.2	-21.83	34.62	8.65	34.11	109	1	Peak
5755	83.19	73.98			34.66	8.66	34.11	109	1	Average
5755	90.45	81.24			34.66	8.66	34.11	109	1	Peak
*5858	57.23	47.91	78.2	-20.97	34.76	8.7	34.14	109	1	Peak
*5862	56.55	47.22	68.2	-11.65	34.76	8.71	34.14	109	1	Peak

Remarks:

- Emission Level = Read Level + Antenna Factor + Cable Loss - Preamp Factor
Margin value = Emission level – Limit value
- 5755 MHz: Fundamental Frequency
- *: Out of Restricted Band

EUT Test Condition		Measurement Detail	
Channel	Channel 159	Frequency Range	1 GHz ~ 40 GHz
Input Power	120 Vac, 60 Hz	Detector Function	Peak (PK) Average (AV)
Environmental Conditions	25 deg. C, 65 % RH	Tested By	Karl Lee

Antenna Polarity & Test Distance: Horizontal at 3 m										
Frequency (MHz)	Emission Level (dBuV/m)	Read Level (dBuV)	Limit (dBuV/m)	Margin (dB)	Antenna Factor (dB/m)	Cable Loss (dB)	Preamp Factor (dB)	Antenna Height (cm)	Table Angle (Degree)	Remark
*5708	55.73	46.58	68.2	-12.47	34.61	8.65	34.11	199	188	Peak
*5716	55.86	46.71	78.2	-22.34	34.61	8.65	34.11	199	188	Peak
5795	80.2	70.96			34.69	8.68	34.13	199	188	Average
5795	87.5	78.26			34.69	8.68	34.13	199	188	Peak
*5860	55.61	46.29	78.2	-22.59	34.76	8.7	34.14	199	188	Peak
*5862	55.93	46.6	68.2	-12.27	34.76	8.71	34.14	199	188	Peak
Antenna Polarity & Test Distance: Vertical at 3 m										
Frequency (MHz)	Emission Level (dBuV/m)	Read Level (dBuV)	Limit (dBuV/m)	Margin (dB)	Antenna Factor (dB/m)	Cable Loss (dB)	Preamp Factor (dB)	Antenna Height (cm)	Table Angle (Degree)	Remark
*5706	56.58	47.43	68.2	-11.62	34.61	8.65	34.11	108	2	Peak
*5720	56.49	47.33	78.2	-21.71	34.62	8.65	34.11	108	2	Peak
5795	82.43	73.19			34.69	8.68	34.13	108	2	Average
5795	90.56	81.32			34.69	8.68	34.13	108	2	Peak
*5858	56.88	47.56	78.2	-21.32	34.76	8.7	34.14	108	2	Peak
*5868	57.77	48.44	68.2	-10.43	34.76	8.71	34.14	108	2	Peak

Remarks:

- Emission Level = Read Level + Antenna Factor + Cable Loss - Preamp Factor
Margin value = Emission level – Limit value
- 5795 MHz: Fundamental Frequency
- *: Out of Restricted Band

802.11ac (VHT80)

EUT Test Condition		Measurement Detail	
Channel	Channel 42	Frequency Range	1 GHz ~ 40 GHz
Input Power	120 Vac, 60 Hz	Detector Function	Peak (PK) Average (AV)
Environmental Conditions	25 deg. C, 65 % RH	Tested By	Karl Lee

Antenna Polarity & Test Distance: Horizontal at 3 m

Frequency (MHz)	Emission Level (dBuV/m)	Read Level (dBuV)	Limit (dBuV/m)	Margin (dB)	Antenna Factor (dB/m)	Cable Loss (dB)	Preamp Factor (dB)	Antenna Height (cm)	Table Angle (Degree)	Remark
5144	45.16	36.91	54	-8.84	34.12	8.13	34	104	300	Average
5144	57.08	48.83	74	-16.92	34.12	8.13	34	104	300	Peak
5210	87.84	79.48			34.17	8.19	34	104	300	Average
5210	95.35	86.99			34.17	8.19	34	104	300	Peak
5434	43.55	34.76	54	-10.45	34.35	8.48	34.04	104	300	Average
5434	57.4	48.61	74	-16.6	34.35	8.48	34.04	104	300	Peak

Antenna Polarity & Test Distance: Vertical at 3 m

Frequency (MHz)	Emission Level (dBuV/m)	Read Level (dBuV)	Limit (dBuV/m)	Margin (dB)	Antenna Factor (dB/m)	Cable Loss (dB)	Preamp Factor (dB)	Antenna Height (cm)	Table Angle (Degree)	Remark
5060	44.06	35.96	54	-9.94	34.05	8.03	33.98	171	276	Average
5060	56.43	48.33	74	-17.57	34.05	8.03	33.98	171	276	Peak
5210	85.53	77.17			34.17	8.19	34	171	276	Average
5210	93.11	84.75			34.17	8.19	34	171	276	Peak
5416	43.77	35.04	54	-10.23	34.33	8.44	34.04	171	276	Average
5416	57.39	48.66	74	-16.61	34.33	8.44	34.04	171	276	Peak

Remarks:

- Emission Level = Read Level + Antenna Factor + Cable Loss - Preamp Factor
Margin value = Emission level – Limit value
- 5210 MHz: Fundamental Frequency



EUT Test Condition		Measurement Detail	
Channel	Channel 58	Frequency Range	1 GHz ~ 40 GHz
Input Power	120 Vac, 60 Hz	Detector Function	Peak (PK) Average (AV)
Environmental Conditions	25 deg. C, 65 % RH	Tested By	Karl Lee

Antenna Polarity & Test Distance: Horizontal at 3 m										
Frequency (MHz)	Emission Level (dBuV/m)	Read Level (dBuV)	Limit (dBuV/m)	Margin (dB)	Antenna Factor (dB/m)	Cable Loss (dB)	Preamp Factor (dB)	Antenna Height (cm)	Table Angle (Degree)	Remark
5100	42.4	34.24	54	-11.6	34.08	8.07	33.99	141	172	Average
5100	57.21	49.05	74	-16.79	34.08	8.07	33.99	141	172	Peak
5290	81.54	73.01			34.23	8.32	34.02	141	172	Average
5290	88.46	79.93			34.23	8.32	34.02	141	172	Peak
5450	43.32	34.5	54	-10.68	34.36	8.51	34.05	141	172	Average
5450	57.32	48.5	74	-16.68	34.36	8.51	34.05	141	172	Peak

Antenna Polarity & Test Distance: Vertical at 3 m										
Frequency (MHz)	Emission Level (dBuV/m)	Read Level (dBuV)	Limit (dBuV/m)	Margin (dB)	Antenna Factor (dB/m)	Cable Loss (dB)	Preamp Factor (dB)	Antenna Height (cm)	Table Angle (Degree)	Remark
5132	42.65	34.43	54	-11.35	34.11	8.1	33.99	101	354	Average
5132	56.46	48.24	74	-17.54	34.11	8.1	33.99	101	354	Peak
5290	87.29	78.76			34.23	8.32	34.02	101	354	Average
5290	94.68	86.15			34.23	8.32	34.02	101	354	Peak
5452	43.77	34.95	54	-10.23	34.36	8.51	34.05	101	354	Average
5452	56.59	47.77	74	-17.41	34.36	8.51	34.05	101	354	Peak

Remarks:

- Emission Level = Read Level + Antenna Factor + Cable Loss - Preamp Factor
Margin value = Emission level – Limit value
- 5290 MHz: Fundamental Frequency



EUT Test Condition		Measurement Detail	
Channel	Channel 106	Frequency Range	1 GHz ~ 40 GHz
Input Power	120 Vac, 60 Hz	Detector Function	Peak (PK) Average (AV)
Environmental Conditions	25 deg. C, 65 % RH	Tested By	Karl Lee

Antenna Polarity & Test Distance: Horizontal at 3 m										
Frequency (MHz)	Emission Level (dBuV/m)	Read Level (dBuV)	Limit (dBuV/m)	Margin (dB)	Antenna Factor (dB/m)	Cable Loss (dB)	Preamp Factor (dB)	Antenna Height (cm)	Table Angle (Degree)	Remark
5366	43.67	35.03	54	-10.33	34.29	8.38	34.03	110	299	Average
5366	55.67	47.03	74	-18.33	34.29	8.38	34.03	110	299	Peak
5470	55.92	47.09	68.2	-12.28	34.37	8.51	34.05	110	299	Peak
5530	83	74.07			34.42	8.58	34.07	110	299	Average
5530	90.73	81.8			34.42	8.58	34.07	110	299	Peak
5725	55.55	46.39	68.2	-12.65	34.62	8.65	34.11	110	299	Peak
Antenna Polarity & Test Distance: Vertical at 3 m										
Frequency (MHz)	Emission Level (dBuV/m)	Read Level (dBuV)	Limit (dBuV/m)	Margin (dB)	Antenna Factor (dB/m)	Cable Loss (dB)	Preamp Factor (dB)	Antenna Height (cm)	Table Angle (Degree)	Remark
5450	43.57	34.75	54	-10.43	34.36	8.51	34.05	124	122	Average
5450	56.64	47.82	74	-17.36	34.36	8.51	34.05	124	122	Peak
5470	54.67	45.84	68.2	-13.53	34.37	8.51	34.05	124	122	Peak
5530	81.44	72.51			34.42	8.58	34.07	124	122	Average
5530	88.13	79.2			34.42	8.58	34.07	124	122	Peak
5725	55.2	46.04	68.2	-13	34.62	8.65	34.11	124	122	Peak

Remarks:

- Emission Level = Read Level + Antenna Factor + Cable Loss - Preamp Factor
Margin value = Emission level – Limit value
- 5530 MHz: Fundamental Frequency
- 5470 MHz & 5725 MHz: Out of Restricted Band



EUT Test Condition		Measurement Detail	
Channel	Channel 122	Frequency Range	1 GHz ~ 40 GHz
Input Power	120 Vac, 60 Hz	Detector Function	Peak (PK) Average (AV)
Environmental Conditions	25 deg. C, 65 % RH	Tested By	Karl Lee

Antenna Polarity & Test Distance: Horizontal at 3 m										
Frequency (MHz)	Emission Level (dBuV/m)	Read Level (dBuV)	Limit (dBuV/m)	Margin (dB)	Antenna Factor (dB/m)	Cable Loss (dB)	Preamp Factor (dB)	Antenna Height (cm)	Table Angle (Degree)	Remark
5440	43.27	34.48	54	-10.73	34.35	8.48	34.04	101	286	Average
5440	57.32	48.53	74	-16.68	34.35	8.48	34.04	101	286	Peak
5470	55.98	47.15	68.2	-12.22	34.37	8.51	34.05	101	286	Peak
5610	83.11	74.08			34.5	8.61	34.08	101	286	Average
5610	90.49	81.46			34.5	8.61	34.08	101	286	Peak
5725	54.63	45.47	68.2	-13.57	34.62	8.65	34.11	101	286	Peak
Antenna Polarity & Test Distance: Vertical at 3 m										
Frequency (MHz)	Emission Level (dBuV/m)	Read Level (dBuV)	Limit (dBuV/m)	Margin (dB)	Antenna Factor (dB/m)	Cable Loss (dB)	Preamp Factor (dB)	Antenna Height (cm)	Table Angle (Degree)	Remark
5450	43.42	34.6	54	-10.58	34.36	8.51	34.05	191	114	Average
5450	57.22	48.4	74	-16.78	34.36	8.51	34.05	191	114	Peak
5470	55.07	46.24	68.2	-13.13	34.37	8.51	34.05	191	114	Peak
5610	81.65	72.62			34.5	8.61	34.08	191	114	Average
5610	88.75	79.72			34.5	8.61	34.08	191	114	Peak
5725	55.3	46.14	68.2	-12.9	34.62	8.65	34.11	191	114	Peak

Remarks:

- Emission Level = Read Level + Antenna Factor + Cable Loss - Preamp Factor
Margin value = Emission level – Limit value
- 5610 MHz: Fundamental Frequency
- 5470 MHz & 5725 MHz: Out of Restricted Band



A D T

EUT Test Condition		Measurement Detail	
Channel	Channel 155	Frequency Range	1 GHz ~ 40 GHz
Input Power	120 Vac, 60 Hz	Detector Function	Peak (PK) Average (AV)
Environmental Conditions	25 deg. C, 65 % RH	Tested By	Karl Lee

Antenna Polarity & Test Distance: Horizontal at 3 m										
Frequency (MHz)	Emission Level (dBuV/m)	Read Level (dBuV)	Limit (dBuV/m)	Margin (dB)	Antenna Factor (dB/m)	Cable Loss (dB)	Preamp Factor (dB)	Antenna Height (cm)	Table Angle (Degree)	Remark
*5706	57.79	48.64	68.2	-10.41	34.61	8.65	34.11	199	188	Peak
*5718	56.53	47.37	78.2	-21.67	34.62	8.65	34.11	199	188	Peak
5775	77.22	67.99			34.68	8.67	34.12	199	188	Average
5775	84.95	75.72			34.68	8.67	34.12	199	188	Peak
*5858	57.22	47.9	78.2	-20.98	34.76	8.7	34.14	199	188	Peak
*5864	57.25	47.92	68.2	-10.95	34.76	8.71	34.14	199	188	Peak
Antenna Polarity & Test Distance: Vertical at 3 m										
Frequency (MHz)	Emission Level (dBuV/m)	Read Level (dBuV)	Limit (dBuV/m)	Margin (dB)	Antenna Factor (dB/m)	Cable Loss (dB)	Preamp Factor (dB)	Antenna Height (cm)	Table Angle (Degree)	Remark
*5710	56.65	47.5	68.2	-11.55	34.61	8.65	34.11	103	2	Peak
*5718	56.03	46.87	78.2	-22.17	34.62	8.65	34.11	103	2	Peak
5775	80.71	71.48			34.68	8.67	34.12	103	2	Average
5775	88.59	79.36			34.68	8.67	34.12	103	2	Peak
*5856	56.62	47.3	78.2	-21.58	34.76	8.7	34.14	103	2	Peak
*5862	55.71	46.38	68.2	-12.49	34.76	8.71	34.14	103	2	Peak

Remarks:

- Emission Level = Read Level + Antenna Factor + Cable Loss - Preamp Factor
Margin value = Emission level – Limit value
- 5775 MHz: Fundamental Frequency
- *: Out of Restricted Band

Mode B
802.11ac (VHT80)

EUT Test Condition		Measurement Detail	
Channel	Channel 42	Frequency Range	1 GHz ~ 40 GHz
Input Power	120 Vac, 60 Hz	Detector Function	Peak (PK) Average (AV)
Environmental Conditions	25 deg. C, 65 % RH	Tested By	Karl Lee

Antenna Polarity & Test Distance: Horizontal at 3 m

Frequency (MHz)	Emission Level (dBuV/m)	Read Level (dBuV)	Limit (dBuV/m)	Margin (dB)	Antenna Factor (dB/m)	Cable Loss (dB)	Preamp Factor (dB)	Antenna Height (cm)	Table Angle (Degree)	Remark
5127	44.71	36.49	54	-9.29	34.11	8.1	33.99	128	117	Average
5127	57.29	49.07	74	-16.71	34.11	8.1	33.99	128	117	Peak
5210	87.64	79.28			34.17	8.19	34	128	117	Average
5210	95.29	86.93			34.17	8.19	34	128	117	Peak
5429	43.69	34.9	54	-10.31	34.35	8.48	34.04	128	117	Average
5429	57.17	48.38	74	-16.83	34.35	8.48	34.04	128	117	Peak

Antenna Polarity & Test Distance: Vertical at 3 m

Frequency (MHz)	Emission Level (dBuV/m)	Read Level (dBuV)	Limit (dBuV/m)	Margin (dB)	Antenna Factor (dB/m)	Cable Loss (dB)	Preamp Factor (dB)	Antenna Height (cm)	Table Angle (Degree)	Remark
5142	43.54	35.28	54	-10.46	34.12	8.13	33.99	164	241	Average
5142	56.39	48.13	74	-17.61	34.12	8.13	33.99	164	241	Peak
5210	85.29	76.93			34.17	8.19	34	164	241	Average
5210	93.27	84.91			34.17	8.19	34	164	241	Peak
5398	43.28	34.56	54	-10.72	34.32	8.44	34.04	164	241	Average
5398	57.24	48.52	74	-16.76	34.32	8.44	34.04	164	241	Peak

Remarks:

- Emission Level = Read Level + Antenna Factor + Cable Loss - Preamp Factor
Margin value = Emission level – Limit value
- 5210 MHz: Fundamental Frequency



EUT Test Condition		Measurement Detail	
Channel	Channel 58	Frequency Range	1 GHz ~ 40 GHz
Input Power	120 Vac, 60 Hz	Detector Function	Peak (PK) Average (AV)
Environmental Conditions	25 deg. C, 65 % RH	Tested By	Karl Lee

Antenna Polarity & Test Distance: Horizontal at 3 m										
Frequency (MHz)	Emission Level (dBuV/m)	Read Level (dBuV)	Limit (dBuV/m)	Margin (dB)	Antenna Factor (dB/m)	Cable Loss (dB)	Preamp Factor (dB)	Antenna Height (cm)	Table Angle (Degree)	Remark
5127	42.39	34.17	54	-11.61	34.11	8.1	33.99	128	274	Average
5127	56.89	48.67	74	-17.11	34.11	8.1	33.99	128	274	Peak
5290	81.25	72.72			34.23	8.32	34.02	128	274	Average
5290	88.51	79.98			34.23	8.32	34.02	128	274	Peak
5397	43.12	34.4	54	-10.88	34.32	8.44	34.04	128	274	Average
5397	57.11	48.39	74	-16.89	34.32	8.44	34.04	128	274	Peak
Antenna Polarity & Test Distance: Vertical at 3 m										
Frequency (MHz)	Emission Level (dBuV/m)	Read Level (dBuV)	Limit (dBuV/m)	Margin (dB)	Antenna Factor (dB/m)	Cable Loss (dB)	Preamp Factor (dB)	Antenna Height (cm)	Table Angle (Degree)	Remark
5087	42.29	34.13	54	-11.71	34.07	8.07	33.98	128	235	Average
5087	56.61	48.45	74	-17.39	34.07	8.07	33.98	128	235	Peak
5290	87.1	78.57			34.23	8.32	34.02	128	235	Average
5290	94.28	85.75			34.23	8.32	34.02	128	235	Peak
5422	42.69	33.92	54	-11.31	34.33	8.48	34.04	128	235	Average
5422	55.91	47.14	74	-18.09	34.33	8.48	34.04	128	235	Peak

Remarks:

- Emission Level = Read Level + Antenna Factor + Cable Loss - Preamp Factor
Margin value = Emission level – Limit value
- 5290 MHz: Fundamental Frequency



EUT Test Condition		Measurement Detail	
Channel	Channel 106	Frequency Range	1 GHz ~ 40 GHz
Input Power	120 Vac, 60 Hz	Detector Function	Peak (PK) Average (AV)
Environmental Conditions	25 deg. C, 65 % RH	Tested By	Karl Lee

Antenna Polarity & Test Distance: Horizontal at 3 m

Frequency (MHz)	Emission Level (dBuV/m)	Read Level (dBuV)	Limit (dBuV/m)	Margin (dB)	Antenna Factor (dB/m)	Cable Loss (dB)	Preamp Factor (dB)	Antenna Height (cm)	Table Angle (Degree)	Remark
5374	43.16	34.5	54	-10.84	34.29	8.41	34.04	128	214	Average
5374	55.12	46.46	74	-18.88	34.29	8.41	34.04	128	214	Peak
5470	54.69	45.86	68.2	-13.51	34.37	8.51	34.05	128	214	Peak
5530	80.74	71.81			34.42	8.58	34.07	128	214	Average
5530	88.64	79.71			34.42	8.58	34.07	128	214	Peak
5725	55.39	46.23	68.2	-12.81	34.62	8.65	34.11	128	214	Peak

Antenna Polarity & Test Distance: Vertical at 3 m

Frequency (MHz)	Emission Level (dBuV/m)	Read Level (dBuV)	Limit (dBuV/m)	Margin (dB)	Antenna Factor (dB/m)	Cable Loss (dB)	Preamp Factor (dB)	Antenna Height (cm)	Table Angle (Degree)	Remark
5395	43.29	34.57	54	-10.71	34.32	8.44	34.04	175	294	Average
5395	56.78	48.06	74	-17.22	34.32	8.44	34.04	175	294	Peak
5470	54.28	45.45	68.2	-13.92	34.37	8.51	34.05	175	294	Peak
5530	78.19	69.26			34.42	8.58	34.07	175	294	Average
5530	85.22	76.29			34.42	8.58	34.07	175	294	Peak
5725	54.97	45.81	68.2	-13.23	34.62	8.65	34.11	175	294	Peak

Remarks:

- Emission Level = Read Level + Antenna Factor + Cable Loss - Preamp Factor
Margin value = Emission level – Limit value
- 5530 MHz: Fundamental Frequency
- 5470 MHz & 5725 MHz: Out of Restricted Band



EUT Test Condition		Measurement Detail	
Channel	Channel 157	Frequency Range	1 GHz ~ 40 GHz
Input Power	120 Vac, 60 Hz	Detector Function	Peak (PK) Average (AV)
Environmental Conditions	25 deg. C, 65 % RH	Tested By	Karl Lee

Antenna Polarity & Test Distance: Horizontal at 3 m										
Frequency (MHz)	Emission Level (dBuV/m)	Read Level (dBuV)	Limit (dBuV/m)	Margin (dB)	Antenna Factor (dB/m)	Cable Loss (dB)	Preamp Factor (dB)	Antenna Height (cm)	Table Angle (Degree)	Remark
*5706	57.26	48.11	74	-16.74	34.61	8.65	34.11	159	241	Peak
*5718	56.69	47.53	74	-17.31	34.62	8.65	34.11	159	241	Peak
5785	82.69	73.46			34.68	8.68	34.13	159	241	Average
5785	90.68	81.45			34.68	8.68	34.13	159	241	Peak
*5856	56.89	47.57	74	-17.11	34.76	8.7	34.14	159	241	Peak
*5864	56.84	47.51	74	-17.16	34.76	8.71	34.14	159	241	Peak
Antenna Polarity & Test Distance: Vertical at 3 m										
Frequency (MHz)	Emission Level (dBuV/m)	Read Level (dBuV)	Limit (dBuV/m)	Margin (dB)	Antenna Factor (dB/m)	Cable Loss (dB)	Preamp Factor (dB)	Antenna Height (cm)	Table Angle (Degree)	Remark
*5706	56.84	47.69	74	-17.16	34.61	8.65	34.11	129	164	Peak
*5719	57.69	48.53	74	-16.31	34.62	8.65	34.11	129	164	Peak
5785	86.75	77.52			34.68	8.68	34.13	129	164	Average
5785	94.58	85.35			34.68	8.68	34.13	129	164	Peak
*5859	56.51	47.19	74	-17.49	34.76	8.7	34.14	129	164	Peak
*5865	57.27	47.94	74	-16.73	34.76	8.71	34.14	129	164	Peak

Remarks:

- Emission Level = Read Level + Antenna Factor + Cable Loss - Preamp Factor
Margin value = Emission level – Limit value
- 5785 MHz: Fundamental Frequency
- *: Out of Restricted Band

9 kHz ~ 30 MHz DATA:

The amplitude of spurious emissions attenuated more than 20 dB below the permissible value is not required to be report.

30 MHz ~ 1 GHz WORST-CASE DATA:
Mode A
802.11ac (VHT80)

EUT Test Condition		Measurement Detail	
Channel	Channel 42	Frequency Range	30 MHz ~ 1 GHz
Input Power	120 Vac, 60 Hz	Detector Function	Peak (PK) Quasi-peak (QP)
Environmental Conditions	25 deg. C, 65 % RH	Tested By	Charles Hsiao

Antenna Polarity & Test Distance: Horizontal at 3 m

Frequency (MHz)	Emission Level (dBuV/m)	Read Level (dBuV)	Limit (dBuV/m)	Margin (dB)	Antenna Factor (dB/m)	Cable Loss (dB)	Preamp Factor (dB)	Antenna Height (cm)	Table Angle (Degree)	Remark
126.93	15.03	36.86	43.5	-28.47	9.03	1.38	32.24	193	150	Peak
146.64	20.89	41.93	43.5	-22.61	9.85	1.38	32.27	138	346	Peak
189.84	20.19	40.43	43.5	-23.31	10.4	1.61	32.25	190	16	Peak
537.3	21.31	30.24	46	-24.69	20.48	2.76	32.17	130	248	Peak
638.8	22.83	29.96	46	-23.17	22.1	2.93	32.16	122	221	Peak
736.8	24.44	30.11	46	-21.56	23.3	3.16	32.13	144	240	Peak

Antenna Polarity & Test Distance: Vertical at 3 m

Frequency (MHz)	Emission Level (dBuV/m)	Read Level (dBuV)	Limit (dBuV/m)	Margin (dB)	Antenna Factor (dB/m)	Cable Loss (dB)	Preamp Factor (dB)	Antenna Height (cm)	Table Angle (Degree)	Remark
34.86	31.41	48.54	40	-8.59	14.37	0.74	32.24	174	325	Peak
89.67	17.35	39.05	43.5	-26.15	8.9	1.11	31.71	189	67	Peak
144.21	14.44	35.66	43.5	-29.06	9.67	1.38	32.27	180	69	Peak
432.3	17.55	29.5	46	-28.45	17.81	2.41	32.17	132	33	Peak
597.5	21.31	29.65	46	-24.69	20.98	2.87	32.19	147	245	Peak
684.3	25.01	30.8	46	-20.99	23.27	3.05	32.11	127	143	Peak

Remarks:

- Emission Level = Read Level + Antenna Factor + Cable Loss - Preamp Factor
Margin value = Emission level – Limit value

802.11ac (VHT80)

EUT Test Condition		Measurement Detail	
Channel	Channel 58	Frequency Range	30 MHz ~ 1 GHz
Input Power	120 Vac, 60 Hz	Detector Function	Peak (PK) Quasi-peak (QP)
Environmental Conditions	25 deg. C, 65 % RH	Tested By	Charles Hsiao

Antenna Polarity & Test Distance: Horizontal at 3 m

Frequency (MHz)	Emission Level (dBuV/m)	Read Level (dBuV)	Limit (dBuV/m)	Margin (dB)	Antenna Factor (dB/m)	Cable Loss (dB)	Preamp Factor (dB)	Antenna Height (cm)	Table Angle (Degree)	Remark
96.42	19.25	40.59	43.5	-24.25	9.42	1.28	32.04	192	254	Peak
146.91	20.96	41.86	43.5	-22.54	9.85	1.52	32.27	198	152	Peak
189.57	20.25	40.49	43.5	-23.25	10.4	1.61	32.25	170	70	Peak
522.6	20.98	29.91	46	-25.02	20.51	2.7	32.14	152	209	Peak
619.2	22.82	30.11	46	-23.18	21.96	2.93	32.18	131	301	Peak
684.3	25.08	30.87	46	-20.92	23.27	3.05	32.11	200	250	Peak

Antenna Polarity & Test Distance: Vertical at 3 m

Frequency (MHz)	Emission Level (dBuV/m)	Read Level (dBuV)	Limit (dBuV/m)	Margin (dB)	Antenna Factor (dB/m)	Cable Loss (dB)	Preamp Factor (dB)	Antenna Height (cm)	Table Angle (Degree)	Remark
45.93	27.41	49.65	40	-12.59	9.08	0.9	32.22	145	96	Peak
54.3	20.65	44.62	40	-19.35	7.36	0.9	32.23	120	206	Peak
145.56	14.31	35.41	43.5	-29.19	9.79	1.38	32.27	197	230	Peak
605.9	21.78	29.71	46	-24.22	21.39	2.87	32.19	160	217	Peak
685.7	24.98	30.76	46	-21.02	23.27	3.05	32.1	110	321	Peak
843.9	25.47	30.17	46	-20.53	23.75	3.38	31.83	123	357	Peak

Remarks:

- Emission Level = Read Level + Antenna Factor + Cable Loss - Preamp Factor
Margin value = Emission level – Limit value



802.11ac (VHT80)

EUT Test Condition		Measurement Detail	
Channel	Channel 106	Frequency Range	30 MHz ~ 1 GHz
Input Power	120 Vac, 60 Hz	Detector Function	Peak (PK) Quasi-peak (QP)
Environmental Conditions	25 deg. C, 65 % RH	Tested By	Charles Hsiao

Antenna Polarity & Test Distance: Horizontal at 3 m

Frequency (MHz)	Emission Level (dBuV/m)	Read Level (dBuV)	Limit (dBuV/m)	Margin (dB)	Antenna Factor (dB/m)	Cable Loss (dB)	Preamp Factor (dB)	Antenna Height (cm)	Table Angle (Degree)	Remark
96.69	20.3	41.7	43.5	-23.2	9.42	1.28	32.1	196	69	Peak
144.75	21.18	42.34	43.5	-22.32	9.73	1.38	32.27	199	198	Peak
198.75	20.28	40.12	43.5	-23.22	10.84	1.61	32.29	100	285	Peak
591.9	22.08	30.67	46	-23.92	20.73	2.87	32.19	120	274	Peak
657	23.21	29.83	46	-22.79	22.53	2.99	32.14	199	299	Peak
707.4	25.16	30.96	46	-20.84	23.19	3.11	32.1	170	174	Peak

Antenna Polarity & Test Distance: Vertical at 3 m

Frequency (MHz)	Emission Level (dBuV/m)	Read Level (dBuV)	Limit (dBuV/m)	Margin (dB)	Antenna Factor (dB/m)	Cable Loss (dB)	Preamp Factor (dB)	Antenna Height (cm)	Table Angle (Degree)	Remark
33.78	30.32	46.72	40	-9.68	15.1	0.74	32.24	125	287	Peak
46.2	27.78	50.1	40	-12.22	9	0.9	32.22	189	51	Peak
144.48	13.67	34.89	43.5	-29.83	9.67	1.38	32.27	138	271	Peak
437.9	18.59	30.4	46	-27.41	17.86	2.49	32.16	185	303	Peak
589.1	21.48	30.2	46	-24.52	20.6	2.87	32.19	158	91	Peak
736.1	24.72	30.36	46	-21.28	23.33	3.16	32.13	136	333	Peak

Remarks:

- Emission Level = Read Level + Antenna Factor + Cable Loss - Preamp Factor
Margin value = Emission level – Limit value



802.11n (HT20)

EUT Test Condition		Measurement Detail	
Channel	Channel 157	Frequency Range	30 MHz ~ 1 GHz
Input Power	120 Vac, 60 Hz	Detector Function	Peak (PK) Quasi-peak (QP)
Environmental Conditions	25 deg. C, 65 % RH	Tested By	Charles Hsiao

Antenna Polarity & Test Distance: Horizontal at 3 m

Frequency (MHz)	Emission Level (dBuV/m)	Read Level (dBuV)	Limit (dBuV/m)	Margin (dB)	Antenna Factor (dB/m)	Cable Loss (dB)	Preamp Factor (dB)	Antenna Height (cm)	Table Angle (Degree)	Remark
98.58	18.54	39.89	43.5	-24.96	9.58	1.28	32.21	185	360	Peak
146.1	21.15	42.25	43.5	-22.35	9.79	1.38	32.27	125	179	Peak
197.4	20.13	40.02	43.5	-23.37	10.79	1.61	32.29	107	88	Peak
528.9	20.92	29.77	46	-25.08	20.61	2.7	32.16	180	209	Peak
671.7	24.65	30.32	46	-21.35	23.4	3.05	32.12	130	305	Peak
744.5	25.37	31.02	46	-20.63	23.27	3.22	32.14	125	253	Peak

Antenna Polarity & Test Distance: Vertical at 3 m

Frequency (MHz)	Emission Level (dBuV/m)	Read Level (dBuV)	Limit (dBuV/m)	Margin (dB)	Antenna Factor (dB/m)	Cable Loss (dB)	Preamp Factor (dB)	Antenna Height (cm)	Table Angle (Degree)	Remark
47.01	28.1	50.68	40	-11.9	8.74	0.9	32.22	101	124	Peak
146.1	14.94	36.04	43.5	-28.56	9.79	1.38	32.27	197	138	Peak
188.49	12.9	33.14	43.5	-30.6	10.4	1.61	32.25	171	104	Peak
465.2	19.94	30.97	46	-26.06	18.54	2.56	32.13	185	54	Peak
603.8	21.96	30.04	46	-24.04	21.24	2.87	32.19	121	287	Peak
727	24.76	30.32	46	-21.24	23.4	3.16	32.12	172	247	Peak

Remarks:

- Emission Level = Read Level + Antenna Factor + Cable Loss - Preamp Factor
Margin value = Emission level – Limit value

Mode B
802.11ac (VHT80)

EUT Test Condition		Measurement Detail	
Channel	Channel 42	Frequency Range	30 MHz ~ 1 GHz
Input Power	120 Vac, 60 Hz	Detector Function	Peak (PK) Quasi-peak (QP)
Environmental Conditions	25 deg. C, 65 % RH	Tested By	Charles Hsiao

Antenna Polarity & Test Distance: Horizontal at 3 m										
Frequency (MHz)	Emission Level (dBuV/m)	Read Level (dBuV)	Limit (dBuV/m)	Margin (dB)	Antenna Factor (dB/m)	Cable Loss (dB)	Preamp Factor (dB)	Antenna Height (cm)	Table Angle (Degree)	Remark
47.28	11.43	34.1	40	-28.57	8.65	0.9	32.22	138	164	Peak
141.51	18.8	40.27	43.5	-24.7	9.42	1.38	32.27	109	166	Peak
230.34	16.03	34.22	46	-29.97	12.13	1.85	32.17	159	127	Peak
402.9	17.3	29.15	46	-28.7	18.03	2.34	32.22	165	192	Peak
619.9	22.58	29.87	46	-23.42	21.96	2.93	32.18	134	116	Peak
907.6	27.08	29.49	46	-18.92	25.48	3.53	31.42	154	112	Peak

Antenna Polarity & Test Distance: Vertical at 3 m										
Frequency (MHz)	Emission Level (dBuV/m)	Read Level (dBuV)	Limit (dBuV/m)	Margin (dB)	Antenna Factor (dB/m)	Cable Loss (dB)	Preamp Factor (dB)	Antenna Height (cm)	Table Angle (Degree)	Remark
54.57	19.45	43.45	40	-20.55	7.33	0.9	32.23	110	122	Peak
117.75	8.99	31.13	43.5	-34.51	8.83	1.28	32.25	139	166	Peak
219	11.42	30.32	46	-34.58	11.67	1.65	32.22	157	124	Peak
414.1	17.53	29.47	46	-28.47	17.85	2.41	32.2	155	178	Peak
636.7	23.1	30.23	46	-22.9	22.1	2.93	32.16	169	125	Peak
971.3	28.64	29.85	54	-25.36	25.88	3.67	30.76	107	123	Peak

Remarks:

- Emission Level = Read Level + Antenna Factor + Cable Loss - Preamp Factor
Margin value = Emission level – Limit value



802.11ac (VHT80)

EUT Test Condition		Measurement Detail	
Channel	Channel 58	Frequency Range	30 MHz ~ 1 GHz
Input Power	120 Vac, 60 Hz	Detector Function	Peak (PK) Quasi-peak (QP)
Environmental Conditions	25 deg. C, 65 % RH	Tested By	Charles Hsiao

Antenna Polarity & Test Distance: Horizontal at 3 m

Frequency (MHz)	Emission Level (dBuV/m)	Read Level (dBuV)	Limit (dBuV/m)	Margin (dB)	Antenna Factor (dB/m)	Cable Loss (dB)	Preamp Factor (dB)	Antenna Height (cm)	Table Angle (Degree)	Remark
45.12	13.42	35.32	40	-26.58	9.42	0.9	32.22	169	127	Peak
133.14	17.02	38.65	43.5	-26.48	9.23	1.38	32.24	154	108	Peak
263.82	13.38	30.14	46	-32.62	13.41	1.94	32.11	125	164	Peak
395.9	17.24	29.31	46	-28.76	17.8	2.34	32.21	194	114	Peak
721.4	24.54	30.13	46	-21.46	23.36	3.16	32.11	165	120	Peak
996.5	29.36	29.95	54	-24.64	26.04	3.72	30.35	127	145	Peak

Antenna Polarity & Test Distance: Vertical at 3 m

Frequency (MHz)	Emission Level (dBuV/m)	Read Level (dBuV)	Limit (dBuV/m)	Margin (dB)	Antenna Factor (dB/m)	Cable Loss (dB)	Preamp Factor (dB)	Antenna Height (cm)	Table Angle (Degree)	Remark
32.97	28.86	44.78	40	-11.14	15.59	0.74	32.25	128	104	Peak
98.85	12.51	33.86	43.5	-30.99	9.58	1.28	32.21	186	128	Peak
220.35	12.08	30.93	46	-33.92	11.72	1.65	32.22	154	129	Peak
412.7	17.86	29.77	46	-28.14	17.88	2.41	32.2	165	132	Peak
507.9	19.75	29.66	46	-26.25	19.57	2.63	32.11	154	172	Peak
901.3	27.47	30.18	46	-18.53	25.24	3.53	31.48	108	145	Peak

Remarks:

- Emission Level = Read Level + Antenna Factor + Cable Loss - Preamp Factor
Margin value = Emission level – Limit value

802.11ac (VHT80)

EUT Test Condition		Measurement Detail	
Channel	Channel 106	Frequency Range	30 MHz ~ 1 GHz
Input Power	120 Vac, 60 Hz	Detector Function	Peak (PK) Quasi-peak (QP)
Environmental Conditions	25 deg. C, 65 % RH	Tested By	Charles Hsiao

Antenna Polarity & Test Distance: Horizontal at 3 m

Frequency (MHz)	Emission Level (dBuV/m)	Read Level (dBuV)	Limit (dBuV/m)	Margin (dB)	Antenna Factor (dB/m)	Cable Loss (dB)	Preamp Factor (dB)	Antenna Height (cm)	Table Angle (Degree)	Remark
90.75	17.63	39.31	43.5	-25.87	8.98	1.11	31.77	132	162	Peak
163.38	16.9	37.13	43.5	-26.6	10.51	1.52	32.26	151	127	Peak
269.76	14.24	30.83	46	-31.76	13.58	1.94	32.11	175	241	Peak
391.7	16.61	28.97	46	-29.39	17.5	2.34	32.2	169	132	Peak
583.5	21.55	30.45	46	-24.45	20.48	2.82	32.2	108	157	Peak
771.1	24.76	30.15	46	-21.24	23.45	3.27	32.11	128	169	Peak

Antenna Polarity & Test Distance: Vertical at 3 m

Frequency (MHz)	Emission Level (dBuV/m)	Read Level (dBuV)	Limit (dBuV/m)	Margin (dB)	Antenna Factor (dB/m)	Cable Loss (dB)	Preamp Factor (dB)	Antenna Height (cm)	Table Angle (Degree)	Remark
35.13	27.19	44.45	40	-12.81	14.24	0.74	32.24	108	165	Peak
78.06	14.05	36.81	40	-25.95	8.34	1.11	32.21	165	254	Peak
194.16	12.64	32.73	43.5	-30.86	10.57	1.61	32.27	154	112	Peak
466.6	19.1	30.04	46	-26.9	18.63	2.56	32.13	106	194	Peak
625.5	23.07	30.21	46	-22.93	22.1	2.93	32.17	154	126	Peak
867.7	26.37	30.01	46	-19.63	24.6	3.44	31.68	108	144	Peak

Remarks:

- Emission Level = Read Level + Antenna Factor + Cable Loss - Preamp Factor
Margin value = Emission level – Limit value



A D T

802.11n (HT20)

EUT Test Condition		Measurement Detail	
Channel	Channel 157	Frequency Range	30 MHz ~ 1 GHz
Input Power	120 Vac, 60 Hz	Detector Function	Peak (PK) Quasi-peak (QP)
Environmental Conditions	25 deg. C, 65 % RH	Tested By	Charles Hsiao

Antenna Polarity & Test Distance: Horizontal at 3 m

Frequency (MHz)	Emission Level (dBuV/m)	Read Level (dBuV)	Limit (dBuV/m)	Margin (dB)	Antenna Factor (dB/m)	Cable Loss (dB)	Preamp Factor (dB)	Antenna Height (cm)	Table Angle (Degree)	Remark
47.55	11.1	33.85	40	-28.9	8.57	0.9	32.22	138	127	Peak
103.17	16.77	38.14	43.5	-26.73	9.61	1.28	32.26	165	128	Peak
228.45	16.63	34.94	46	-29.37	12.02	1.85	32.18	158	117	Peak
383.3	15.92	28.85	46	-30.08	16.9	2.34	32.17	155	120	Peak
510.7	20.3	29.96	46	-25.7	19.76	2.7	32.12	187	149	Peak
872.6	26.1	29.51	46	-19.9	24.8	3.44	31.65	108	126	Peak

Antenna Polarity & Test Distance: Vertical at 3 m

Frequency (MHz)	Emission Level (dBuV/m)	Read Level (dBuV)	Limit (dBuV/m)	Margin (dB)	Antenna Factor (dB/m)	Cable Loss (dB)	Preamp Factor (dB)	Antenna Height (cm)	Table Angle (Degree)	Remark
54.3	19.87	43.84	40	-20.13	7.36	0.9	32.23	169	135	Peak
132.87	12.51	34.14	43.5	-30.99	9.23	1.38	32.24	174	124	Peak
240.33	12.73	30.42	46	-33.27	12.59	1.85	32.13	108	125	Peak
416.2	17.78	29.76	46	-28.22	17.81	2.41	32.2	134	112	Peak
598.2	21.74	30.08	46	-24.26	20.98	2.87	32.19	168	127	Peak
936.3	27.74	29.13	46	-18.26	26.2	3.62	31.21	108	122	Peak

Remarks:

- Emission Level = Read Level + Antenna Factor + Cable Loss - Preamp Factor
Margin value = Emission level – Limit value

4.2 Conducted Emission Measurement

4.2.1 Limits of Conducted Emission Measurement

Frequency (MHz)	Conducted Limit (dBuV)	
	Quasi-peak	Average
0.15 - 0.5	66 - 56	56 - 46
0.50 - 5.0	56	46
5.0 - 30.0	60	50

Note: 1. The lower limit shall apply at the transition frequencies.

2. The limit decreases in line with the logarithm of the frequency in the range of 0.15 to 0.50 MHz.

4.2.2 Test Instruments

Description & Manufacturer	Model No.	Serial No.	Date Of Calibration	Due Date Of Calibration
Test Receiver ROHDE & SCHWARZ	ESCI	100613	Nov. 16, 2015	Nov. 15, 2016
RF signal cable (with 10dB PAD) Woken	5D-FB	Cable-cond1-01	Dec. 26, 2015	Dec. 25, 2016
LISN ROHDE & SCHWARZ (EUT)	ESH3-Z5	835239/001	Feb. 26, 2016	Feb. 25, 2017
LISN ROHDE & SCHWARZ (Peripheral)	ESH3-Z5	100311	Jul. 24, 2015	Jul. 23, 2016
Software ADT	BV ADT_Cond_ V7.3.7.3	NA	NA	NA

Note: 1. The calibration interval of the above test instruments is 12 months and the calibrations are traceable to NML/ROC and NIST/USA.

2. The test was performed in HwaYa Shielded Room 1.

3. The VCCI Site Registration No. is C-2040.

4.2.3 Test Procedures

- a. The EUT was placed 0.4 meters from the conducting wall of the shielded room with EUT being connected to the power mains through a line impedance stabilization network (LISN). Other support units were connected to the power mains through another LISN. The two LISNs provide 50 ohm/ 50uH of coupling impedance for the measuring instrument.
- b. Both lines of the power mains connected to the EUT were checked for maximum conducted interference.
- c. The frequency range from 150 kHz to 30 MHz was searched. Emission levels under (Limit -20 dB) was not recorded.

NOTE: All modes of operation were investigated and the worst-case emissions are reported.

4.2.4 Deviation from Test Standard

No deviation.

4.2.5 Test Setup

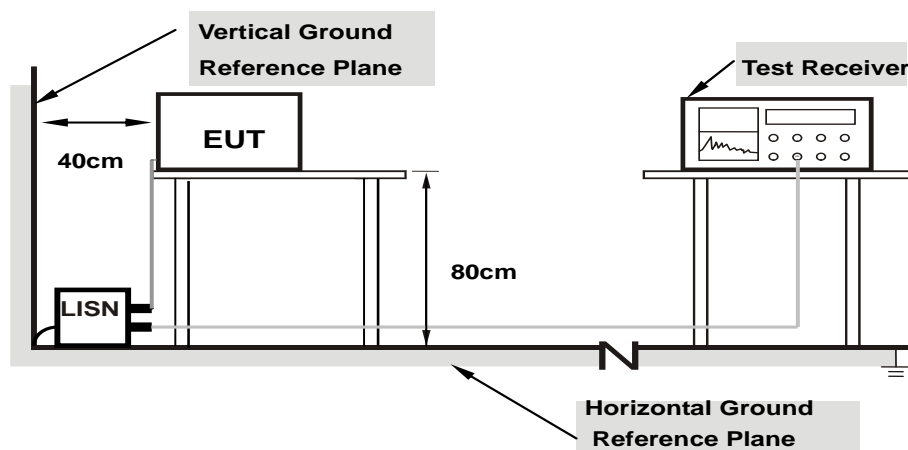

- Note:**
- 1.Support units were connected to second LISN.
 - 2.Both of LISNs (AMN) are 80 cm from EUT and at least 80 from other units and other metal planes

For the actual test configuration, please refer to the attached file (Test Setup Photo).

4.2.6 EUT Operating Conditions

- a. Placed the EUT on a testing table.
- b. Use the software to control the EUT under transmission condition continuously at specific channel frequency.

4.2.7 Test Results

Mode A

Frequency Range	150kHz ~ 30MHz	Detector Function & Resolution Bandwidth	Quasi-Peak (QP) / Average (AV), 9kHz
Input Power	120Vac, 60Hz	Environmental Conditions	25°C, 65%RH
Tested by	Toby Tian	Test Date	2016/4/15

Phase Of Power : Line (L)										
No	Frequency (MHz)	Correction Factor (dB)	Reading Value (dBuV)		Emission Level (dBuV)		Limit (dBuV)		Margin (dB)	
			Q.P.	AV.	Q.P.	AV.	Q.P.	AV.	Q.P.	AV.
1	0.15400	10.02	34.44	21.71	44.46	31.73	65.78	55.78	-21.33	-24.06
2	0.19800	10.03	30.31	17.38	40.34	27.41	63.69	53.69	-23.35	-26.28
3	0.29400	10.07	25.40	11.59	35.47	21.66	60.41	50.41	-24.94	-28.75
4	0.61000	10.15	27.89	20.63	38.04	30.78	56.00	46.00	-17.96	-15.22
5	2.07800	10.28	18.00	9.27	28.28	19.55	56.00	46.00	-27.72	-26.45
6	10.30200	10.75	29.39	15.36	40.14	26.11	60.00	50.00	-19.86	-23.89

Remarks:

1. Q.P. and AV. are abbreviations of quasi-peak and average individually.
2. The emission levels of other frequencies were very low against the limit.
3. Margin value = Emission level – Limit value
4. Correction factor = Insertion loss + Cable loss
5. Emission Level = Correction Factor + Reading Value

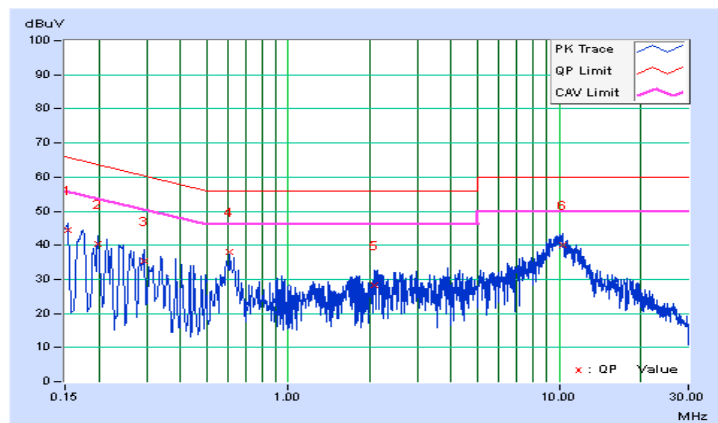

Frequency Range	150kHz ~ 30MHz	Detector Function & Resolution Bandwidth	Quasi-Peak (QP) / Average (AV), 9kHz
Input Power	120Vac, 60Hz	Environmental Conditions	25°C, 65%RH
Tested by	Toby Tian	Test Date	2016/4/15

Phase Of Power : Neutral (N)										
No	Frequency (MHz)	Correction Factor (dB)	Reading Value (dBuV)		Emission Level (dBuV)		Limit (dBuV)		Margin (dB)	
			Q.P.	AV.	Q.P.	AV.	Q.P.	AV.	Q.P.	AV.
1	0.15800	10.03	32.75	19.41	42.78	29.44	65.57	55.57	-22.79	-26.13
2	0.22600	10.05	27.93	14.55	37.98	24.60	62.60	52.60	-24.61	-27.99
3	0.60603	10.16	32.04	29.68	42.20	39.84	56.00	46.00	-13.80	-6.16
4	1.12200	10.22	24.33	17.26	34.55	27.48	56.00	46.00	-21.45	-18.52
5	2.12200	10.29	23.44	15.48	33.73	25.77	56.00	46.00	-22.27	-20.23
6	9.27800	10.76	32.04	18.78	42.80	29.54	60.00	50.00	-17.20	-20.46

Remarks:

1. Q.P. and AV. are abbreviations of quasi-peak and average individually.
2. The emission levels of other frequencies were very low against the limit.
3. Margin value = Emission level – Limit value
4. Correction factor = Insertion loss + Cable loss
5. Emission Level = Correction Factor + Reading Value

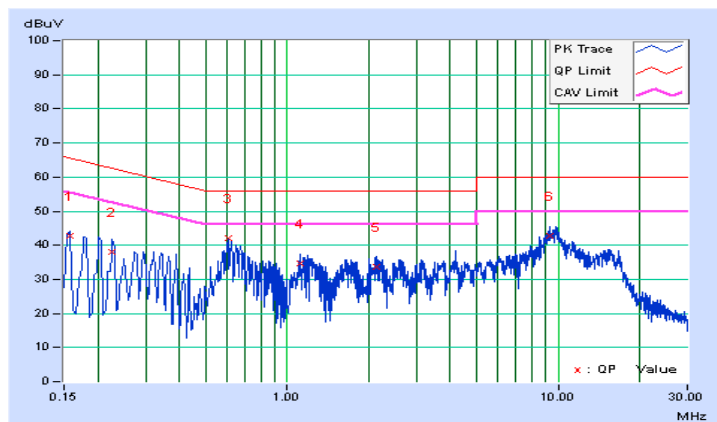

Mode B

Frequency Range	150kHz ~ 30MHz	Detector Function & Resolution Bandwidth	Quasi-Peak (QP) / Average (AV), 9kHz
Input Power	120Vac, 60Hz	Environmental Conditions	25°C, 65%RH
Tested by	Toby Tian	Test Date	2016/4/14

Phase Of Power : Line (L)										
No	Frequency (MHz)	Correction Factor (dB)	Reading Value (dBuV)		Emission Level (dBuV)		Limit (dBuV)		Margin (dB)	
			Q.P.	AV.	Q.P.	AV.	Q.P.	AV.	Q.P.	AV.
1	0.17000	10.02	40.12	23.03	50.14	33.05	64.96	54.96	-14.82	-21.91
2	0.23000	10.04	35.62	20.07	45.66	30.11	62.45	52.45	-16.79	-22.34
3	0.60603	10.15	33.68	21.16	43.83	31.31	56.00	46.00	-12.17	-14.69
4	1.71000	10.25	33.73	22.95	43.98	33.20	56.00	46.00	-12.02	-12.80
5	3.96552	10.41	32.78	24.14	43.19	34.55	56.00	46.00	-12.81	-11.45
6	10.09000	10.74	38.00	25.42	48.74	36.16	60.00	50.00	-11.26	-13.84

Remarks:

1. Q.P. and AV. are abbreviations of quasi-peak and average individually.
2. The emission levels of other frequencies were very low against the limit.
3. Margin value = Emission level – Limit value
4. Correction factor = Insertion loss + Cable loss
5. Emission Level = Correction Factor + Reading Value

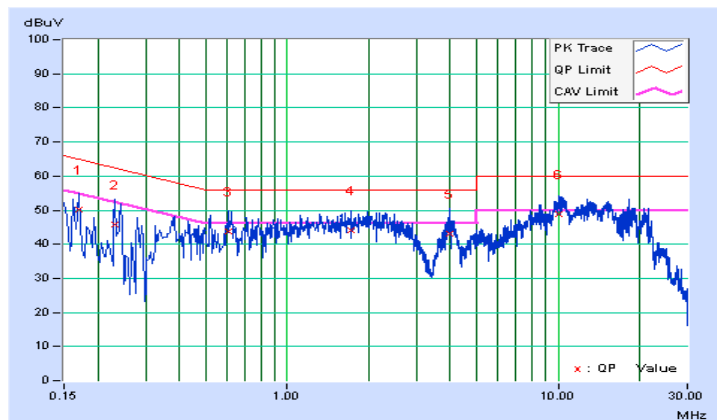

Frequency Range	150kHz ~ 30MHz	Detector Function & Resolution Bandwidth	Quasi-Peak (QP) / Average (AV), 9kHz
Input Power	120Vac, 60Hz	Environmental Conditions	25°C, 65%RH
Tested by	Toby Tian	Test Date	2016/4/14

Phase Of Power : Neutral (N)										
No	Frequency (MHz)	Correction Factor (dB)	Reading Value (dBuV)		Emission Level (dBuV)		Limit (dBuV)		Margin (dB)	
			Q.P.	AV.	Q.P.	AV.	Q.P.	AV.	Q.P.	AV.
1	0.15800	10.03	45.11	26.95	55.14	36.98	65.57	55.57	-10.43	-18.59
2	0.25400	10.06	33.18	17.74	43.24	27.80	61.63	51.63	-18.38	-23.82
3	1.29800	10.23	28.96	17.53	39.19	27.76	56.00	46.00	-16.81	-18.24
4	2.23000	10.30	31.78	20.56	42.08	30.86	56.00	46.00	-13.92	-15.14
5	4.09800	10.44	36.63	26.24	47.07	36.68	56.00	46.00	-8.93	-9.32
6	10.26200	10.82	36.58	25.32	47.40	36.14	60.00	50.00	-12.60	-13.86

Remarks:

1. Q.P. and AV. are abbreviations of quasi-peak and average individually.
2. The emission levels of other frequencies were very low against the limit.
3. Margin value = Emission level – Limit value
4. Correction factor = Insertion loss + Cable loss
5. Emission Level = Correction Factor + Reading Value

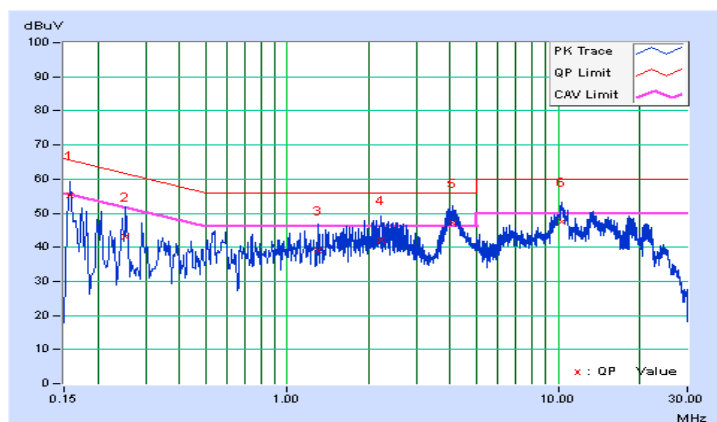

4.3 Transmit Power Measurement

4.3.1 Limits of Transmit Power Measurement

Operation Band	EUT Category	Limit
U-NII-1	Outdoor Access Point	1 Watt (30 dBm) (Max. e.i.r.p \leq 125 mW (21 dBm) at any elevation angle above 30 degrees as measured from the horizon)
	Fixed point-to-point Access Point	1 Watt (30 dBm)
	Indoor Access Point	1 Watt (30 dBm)
	√ Mobile and Portable client device	250 mW (24 dBm)
U-NII-2A	√	250 mW (24 dBm) or 11 dBm+10 log B*
U-NII-2C	√	250 mW (24 dBm) or 11 dBm+10 log B*
U-NII-3	√	1 Watt (30 dBm)

*B is the 26 dB emission bandwidth in megahertz

4.3.2 Test Setup

<Power Output Measurement>

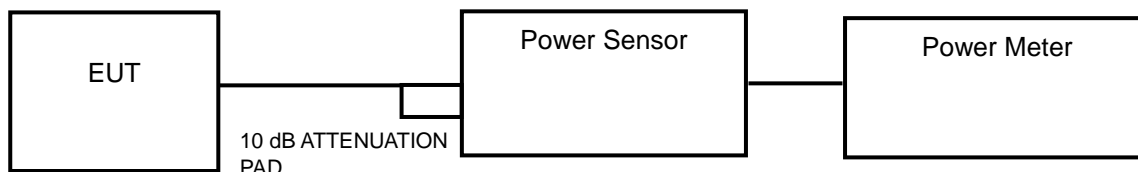

or

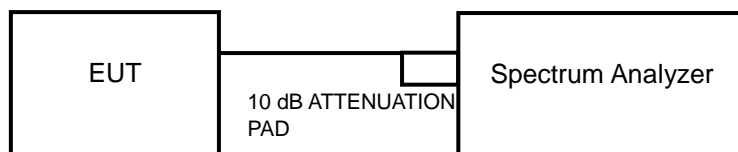

<26 dB Bandwidth>

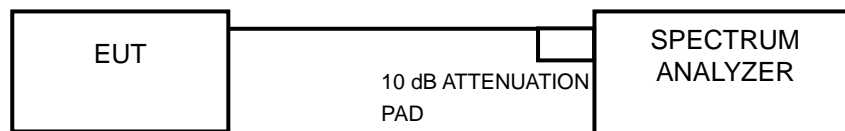

4.3.3 Test Instruments

Refer to section 4.1.2 to get information of above instrument.

4.3.4 Test Procedure

Average Power Measurement

<802.11a, 802.11n (HT20), 802.11n (HT40)>

Method PM is used to perform output power measurement, trigger and gating function of wide band power meter is enabled to measure max output power of TX on burst. Duty factor is not added to measured value.

<802.11ac (VHT80)>

Method SA-1 is used to perform output power measurement, trigger and gating function of spectrum analyzer is enabled to measure max output power of TX on burst. Duty factor is not added to measured value.

26 dB Bandwidth

- 1) Set RBW = approximately 1 % of the emission bandwidth.
- 2) Set the VBW > RBW.
- 3) Detector = Peak.
- 4) Trace mode = max hold.
- 5) Measure the maximum width of the emission that is 26 dB down from the peak of the emission. Compare this with the RBW setting of the analyzer. Readjust RBW and repeat measurement as needed until the RBW/EBW ratio is approximately 1 %.

4.3.5 Deviation from Test Standard

No deviation.

4.3.6 EUT Operating Conditions

The software provided by client to enable the EUT under transmission condition continuously at lowest, middle and highest channel frequencies individually.

4.3.7 Test Result

Power Output:

802.11a

Channel	Frequency (MHz)	Maximum Conducted Power (mW)	Maximum Conducted Power (dBm)	Power Limit (dBm)	Pass / Fail
36	5180	17.54	12.44	24	Pass
44	5220	18.84	12.75	24	Pass
48	5240	18.62	12.70	24	Pass
52	5260	18.88	12.76	24	Pass
60	5300	19.68	12.94	24	Pass
64	5320	19.19	12.83	24	Pass
100	5500	17.74	12.49	24	Pass
116	5580	18.41	12.65	24	Pass
140	5700	17.62	12.46	24	Pass
149	5745	17.06	12.32	30	Pass
157	5785	17.30	12.38	30	Pass
165	5825	16.44	12.16	30	Pass

NOTE:

For U-NII-2A, U-NII-2C Band:

1. $11 \text{ dBm} + 10\log(22.61) = 24.54 \text{ dBm} > 24 \text{ dBm}$.
2. $11 \text{ dBm} + 10\log(22.50) = 24.52 \text{ dBm} > 24 \text{ dBm}$.
3. $11 \text{ dBm} + 10\log(22.53) = 24.53 \text{ dBm} > 24 \text{ dBm}$.
4. $11 \text{ dBm} + 10\log(22.48) = 24.52 \text{ dBm} > 24 \text{ dBm}$.
5. $11 \text{ dBm} + 10\log(22.53) = 24.53 \text{ dBm} > 24 \text{ dBm}$.
6. $11 \text{ dBm} + 10\log(22.71) = 24.56 \text{ dBm} > 24 \text{ dBm}$.

802.11n (HT20)

Channel	Frequency (MHz)	Maximum Conducted Power (mW)	Maximum Conducted Power (dBm)	Power Limit (dBm)	Pass / Fail
36	5180	18.41	12.65	24	Pass
44	5220	19.41	12.88	24	Pass
48	5240	19.10	12.81	24	Pass
52	5260	18.79	12.74	24	Pass
60	5300	19.50	12.90	24	Pass
64	5320	19.19	12.83	24	Pass
100	5500	17.62	12.46	24	Pass
116	5580	18.54	12.68	24	Pass
140	5700	18.07	12.57	24	Pass
149	5745	16.94	12.29	30	Pass
157	5785	17.22	12.36	30	Pass
165	5825	16.00	12.04	30	Pass

NOTE:
For U-NII-2A, U-NII-2C Band:

1. $11 \text{ dBm} + 10\log(22.51) = 24.52 \text{ dBm} > 24 \text{ dBm}$.
2. $11 \text{ dBm} + 10\log(22.50) = 24.52 \text{ dBm} > 24 \text{ dBm}$.
3. $11 \text{ dBm} + 10\log(22.45) = 24.51 \text{ dBm} > 24 \text{ dBm}$.
4. $11 \text{ dBm} + 10\log(22.47) = 24.52 \text{ dBm} > 24 \text{ dBm}$.
5. $11 \text{ dBm} + 10\log(22.50) = 24.52 \text{ dBm} > 24 \text{ dBm}$.
6. $11 \text{ dBm} + 10\log(22.59) = 24.54 \text{ dBm} > 24 \text{ dBm}$.

802.11n (HT40)

Channel	Frequency (MHz)	Maximum Conducted Power (mW)	Maximum Conducted Power (dBm)	Power Limit (dBm)	Pass / Fail
38	5190	16.37	12.14	24	Pass
46	5230	17.22	12.36	24	Pass
54	5270	16.83	12.26	24	Pass
62	5310	17.38	12.40	24	Pass
102	5510	15.38	11.87	24	Pass
110	5550	15.70	11.96	24	Pass
134	5670	16.41	12.15	24	Pass
151	5755	15.67	11.95	30	Pass
159	5795	14.79	11.7	30	Pass

NOTE:
For U-NII-2A, U-NII-2C Band:

1. $11 \text{ dBm} + 10\log(45.17) = 27.55 \text{ dBm} > 24 \text{ dBm}$.
2. $11 \text{ dBm} + 10\log(45.15) = 27.55 \text{ dBm} > 24 \text{ dBm}$.
3. $11 \text{ dBm} + 10\log(45.19) = 27.55 \text{ dBm} > 24 \text{ dBm}$.
4. $11 \text{ dBm} + 10\log(45.22) = 27.55 \text{ dBm} > 24 \text{ dBm}$.
5. $11 \text{ dBm} + 10\log(45.05) = 27.54 \text{ dBm} > 24 \text{ dBm}$.

802.11ac (VHT80)

Channel	Frequency (MHz)	Maximum Conducted Power (mW)	Maximum Conducted Power (dBm)	Power Limit (dBm)	Pass / Fail
42	5210	12.94	11.12	24	Pass
58	5290	15.38	11.87	24	Pass
106	5530	16.14	12.08	24	Pass
122	5610	14.32	11.56	24	Pass
155	5775	13.15	11.19	30	Pass

Note:
For U-NII-2A, U-NII-2C Band:

1. $11 \text{ dBm} + 10\log(85.78) = 30.33 \text{ dBm} > 24 \text{ dBm}$.
2. $11 \text{ dBm} + 10\log(84.60) = 30.27 \text{ dBm} > 24 \text{ dBm}$.
3. $11 \text{ dBm} + 10\log(84.58) = 30.27 \text{ dBm} > 24 \text{ dBm}$.

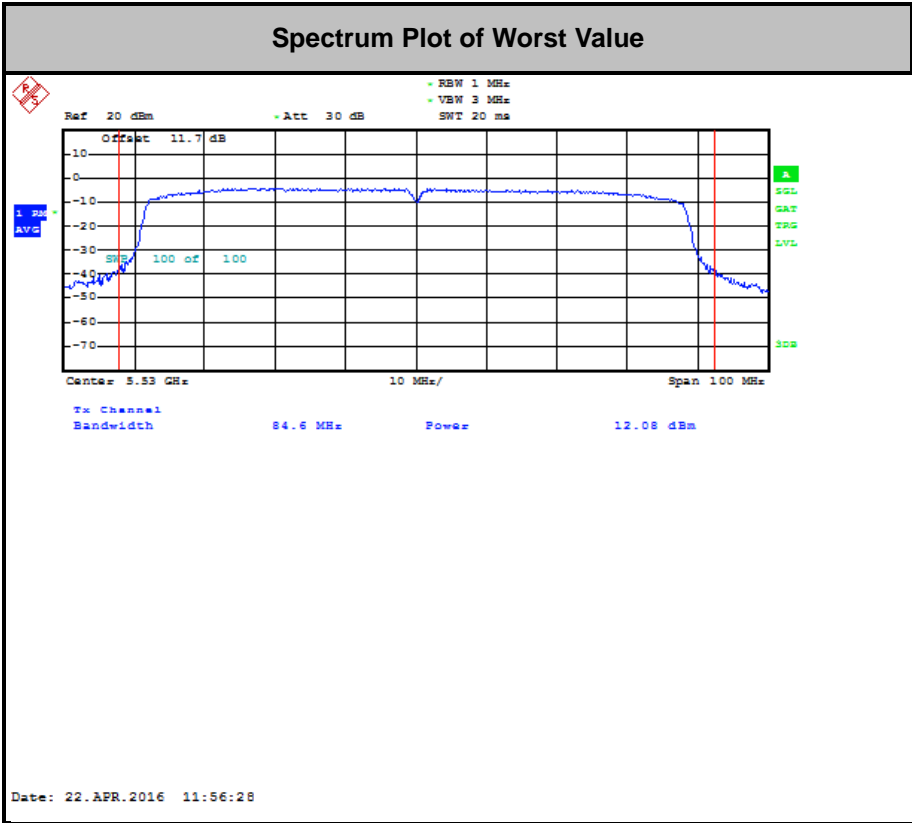

26 dB Bandwidth:
802.11a

Channel	Frequency (MHz)	26 dBc Bandwidth (MHz)	Pass / Fail
36	5180	22.33	Pass
44	5220	22.85	Pass
48	5240	22.54	Pass
52	5260	22.61	Pass
60	5300	22.50	Pass
64	5320	22.53	Pass
100	5500	22.48	Pass
116	5580	22.53	Pass
140	5700	22.71	Pass

802.11n (HT20)

Channel	Frequency (MHz)	26 dBc Bandwidth (MHz)	Pass / Fail
36	5180	22.44	Pass
44	5220	22.45	Pass
48	5240	22.53	Pass
52	5260	22.51	Pass
60	5300	22.50	Pass
64	5320	22.45	Pass
100	5500	22.47	Pass
116	5580	22.50	Pass
140	5700	22.59	Pass

802.11n (HT40)

Channel	Frequency (MHz)	26 dBc Bandwidth (MHz)	Pass / Fail
38	5190	45.15	Pass
46	5230	45.02	Pass
54	5270	45.17	Pass
62	5310	45.15	Pass
102	5510	45.19	Pass
110	5550	45.22	Pass
134	5670	45.05	Pass

802.11ac (VHT80)

Channel	Frequency (MHz)	26 dBc Bandwidth (MHz)	Pass / Fail
42	5210	85.56	Pass
58	5290	85.78	Pass
106	5530	84.60	Pass
122	5610	84.58	Pass

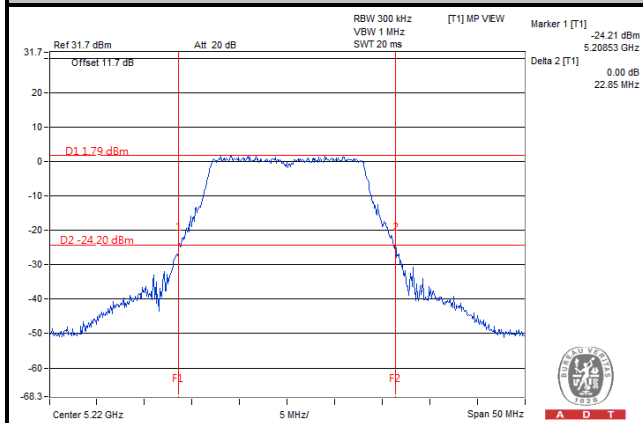
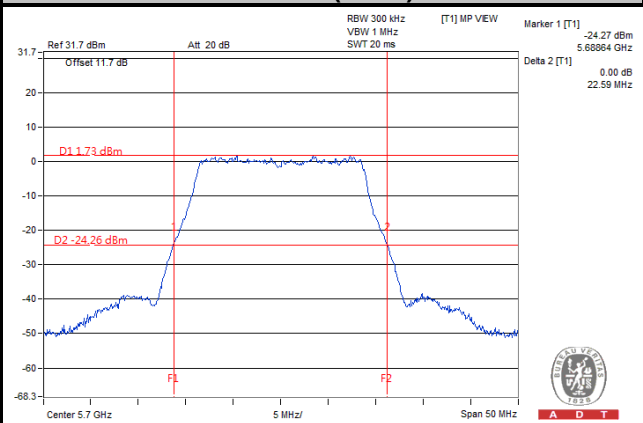
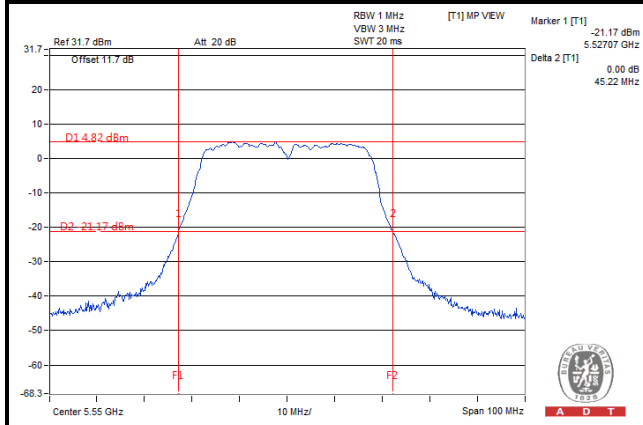
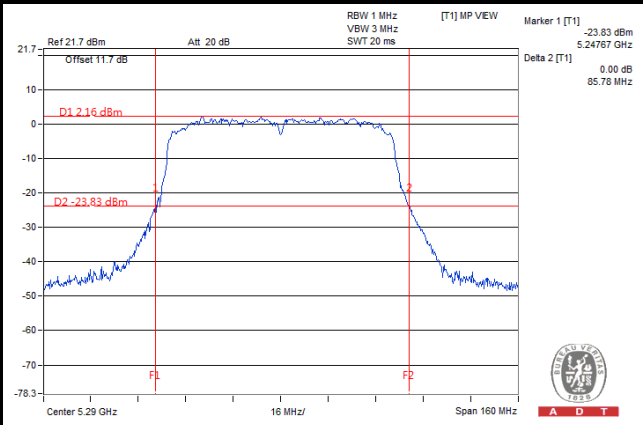
Spectrum Plot of Worst Value
802.11a

802.11n (HT20)

802.11n (HT40)

802.11ac (VHT80)

4.4 Peak Power Spectral Density Measurement

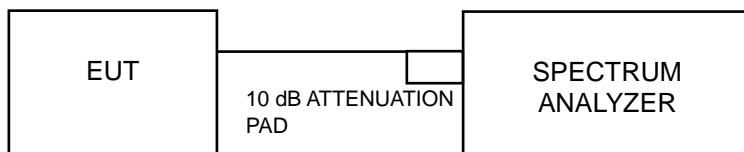
4.4.1 Limits of Peak Power Spectral Density Measurement

Operation Band	EUT Category		Limit
U-NII-1		Outdoor Access Point	17 dBm/MHz
		Fixed point-to-point Access Point	
		Indoor Access Point	
	√	Mobile and Portable client device	11 dBm/MHz
U-NII-2A		√	11 dBm/MHz
U-NII-2C		√	11 dBm/MHz
U-NII-3		√	30 dBm/500 kHz

4.4.2 Test Setup



4.4.3 Test Instruments

Refer to section 4.1.3 to get information of above instrument.

4.4.4 Test Procedures

For U-NII-1, U-NII-2A, U-NII-2C band:

Using method SA-2

1. Set span to encompass the entire emission bandwidth (EBW) of the signal.
2. Set RBW = 1 MHz, Set VBW \geq 3 RBW, Detector = RMS
3. Sweep time = auto, trigger set to "free run".
4. Trace average at least 100 traces in power averaging mode.
5. Record the max value and add 10 log (1/duty cycle)

For U-NII-3:

1. Set span to encompass the entire emission bandwidth (EBW) of the signal.
2. Set RBW = 500 kHz, Set VBW \geq 3 RBW, Detector = RMS
3. Use the peak marker function to determine the maximum power level in any 500 kHz band segment within the fundamental EBW.
4. Sweep time = auto, trigger set to "free run".
5. Trace average at least 100 traces in power averaging mode.
6. Record the max value and add 10 log (1/duty cycle)

4.4.5 Deviation from Test Standard

No deviation.

4.4.6 EUT Operating Conditions

The software provided by client to enable the EUT under transmission condition continuously at lowest, middle and highest channel frequencies individually.

4.4.7 Test Results

For U-NII-1, U-NII-2A, U-NII-2C Band

802.11a

Channel	Frquency (MHz)	PSD w/o Duty Factor (dBm)	Duty Factor	PSD with Duty Factor (dBm)	Maximum Limit (dBm)	Pass / Fail
36	5180	-2.34	0.62	-1.72	11	Pass
44	5220	-2.07	0.62	-1.45	11	Pass
48	5240	-1.83	0.62	-1.21	11	Pass
52	5260	-1.51	0.62	-0.89	11	Pass
60	5300	-1.11	0.62	-0.49	11	Pass
64	5320	-1.05	0.62	-0.43	11	Pass
100	5500	-0.48	0.62	0.14	11	Pass
116	5580	-0.82	0.62	-0.20	11	Pass
140	5700	-1.65	0.62	-1.03	11	Pass

NOTE: Refer to section 3.3 for duty cycle spectrum plot.

802.11n (HT20)

Channel	Frequency (MHz)	PSD w/o Duty Factor (dBm)	Duty Factor	PSD with Duty Factor (dBm)	Maximum Limit (dBm)	Pass / Fail
36	5180	-2.61	0.85	-1.76	11	Pass
44	5220	-2.48	0.85	-1.63	11	Pass
48	5240	-2.12	0.85	-1.27	11	Pass
52	5260	-2.03	0.85	-1.18	11	Pass
60	5300	-1.61	0.85	-0.76	11	Pass
64	5320	-1.31	0.85	-0.46	11	Pass
100	5500	-0.87	0.85	-0.02	11	Pass
116	5580	-1.29	0.85	-0.44	11	Pass
140	5700	-2.02	0.85	-1.17	11	Pass

NOTE: Refer to section 3.3 for duty cycle spectrum plot.

802.11n (HT40)

Channel	Frequency (MHz)	PSD w/o Duty Factor (dBm)	Duty Factor	PSD with Duty Factor (dBm)	Maximum Limit (dBm)	Pass / Fail
38	5190	-5.21	1.79	-3.42	11	Pass
46	5230	-4.93	1.79	-3.14	11	Pass
54	5270	-4.61	1.79	-2.82	11	Pass
62	5310	-4.06	1.79	-2.27	11	Pass
102	5510	-3.59	1.79	-1.80	11	Pass
110	5550	-3.69	1.79	-1.90	11	Pass
134	5670	-4.45	1.79	-2.66	11	Pass

NOTE: Refer to section 3.3 for duty cycle spectrum plot.

802.11ac (VHT80)

Channel	Frequency (MHz)	PSD w/o Duty Factor (dBm)	Duty Factor	PSD with Duty Factor (dBm)	Maximum Limit (dBm)	Pass / Fail
42	5210	-9.32	3.17	-6.15	11	Pass
58	5290	-8.31	3.17	-5.14	11	Pass
106	5530	-7.79	3.17	-4.62	11	Pass
122	5610	-8.22	3.17	-5.05	11	Pass

Note: Refer to section 3.3 for duty cycle spectrum plot.

Spectrum Plot of Worst Value

802.11a

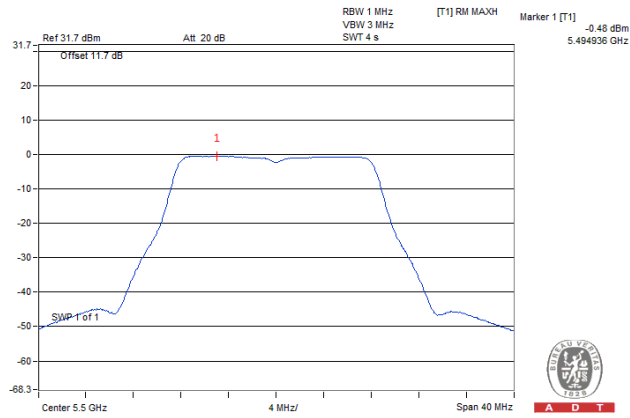

802.11n (HT20)

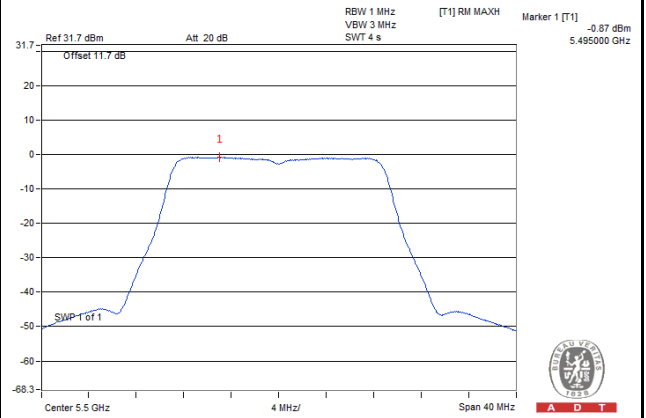

802.11n (HT40)

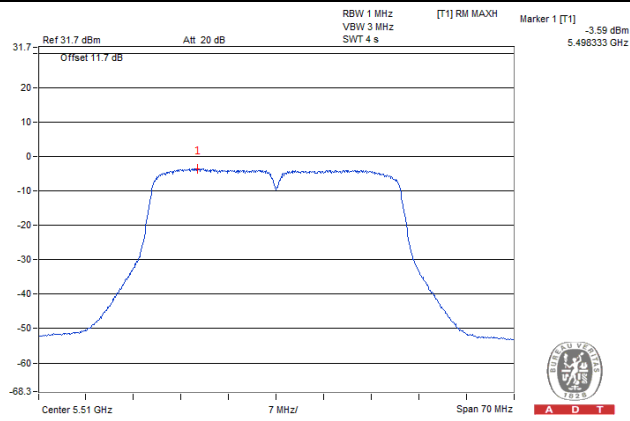

802.11ac (VHT80)

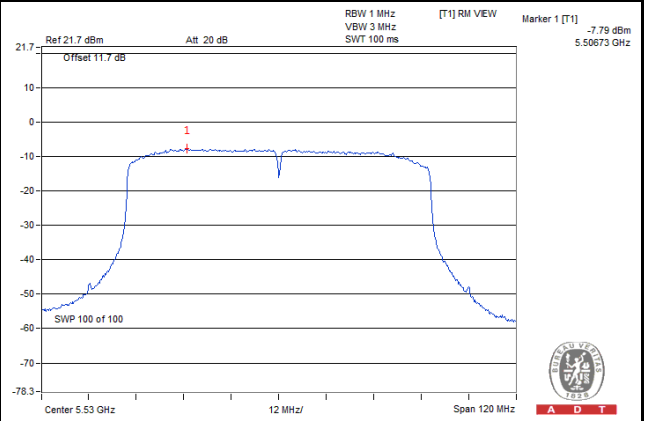

For U-NII-3 Band

802.11a

Channel	Frequency (MHz)	PSD w/o Duty Factor (dBm)	Duty Factor	PSD with Duty Factor (dBm)	Limit (dBm/500 kHz)	Pass / Fail
149	5745	-5.24	0.62	-4.62	30	Pass
157	5785	-5.37	0.62	-4.75	30	Pass
165	5825	-4.94	0.62	-4.32	30	Pass

NOTE: Refer to section 3.3 for duty cycle spectrum plot.

802.11n (HT20)

Channel	Frequency (MHz)	PSD w/o Duty Factor (dBm)	Duty Factor	PSD with Duty Factor (dBm)	Limit (dBm/500 kHz)	Pass / Fail
149	5745	-4.74	0.85	-3.89	30	Pass
157	5785	-5.58	0.85	-4.73	30	Pass
165	5825	-5.27	0.85	-4.42	30	Pass

NOTE: Refer to section 3.3 for duty cycle spectrum plot.

802.11n (HT40)

Channel	Frequency (MHz)	PSD w/o Duty Factor (dBm)	Duty Factor	PSD with Duty Factor (dBm)	Limit (dBm/500 kHz)	Pass / Fail
151	5755	-8.80	1.79	-7.01	30	Pass
159	5795	-9.26	1.79	-7.47	30	Pass

NOTE: Refer to section 3.3 for duty cycle spectrum plot.

802.11ac (VHT80)

Channel	Frequency (MHz)	PSD w/o Duty Factor (dBm)	Duty Factor	PSD with Duty Factor (dBm)	Limit (dBm/500 kHz)	Pass / Fail
155	5775	-13.31	3.17	-10.14	30	Pass

Note: Refer to section 3.3 for duty cycle spectrum plot.

Spectrum Plot of Worst Value

802.11a

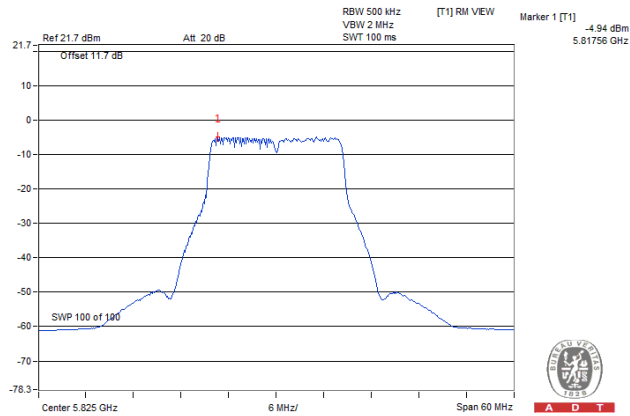

802.11n (HT20)

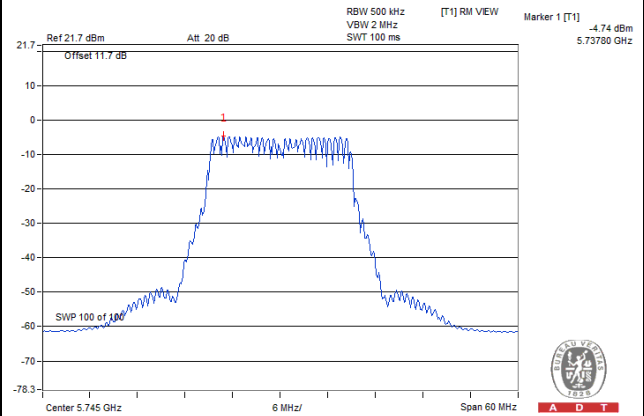

802.11n (HT40)

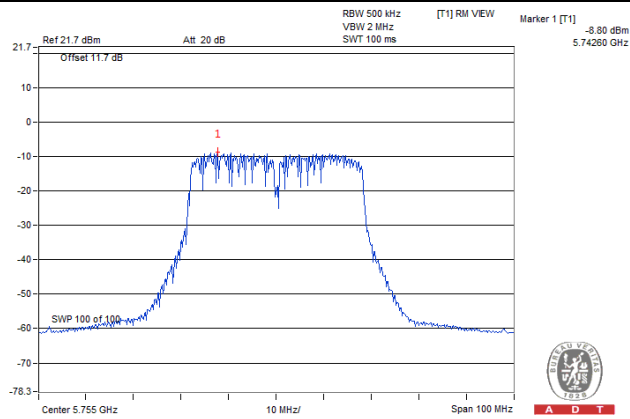

802.11ac (VHT80)

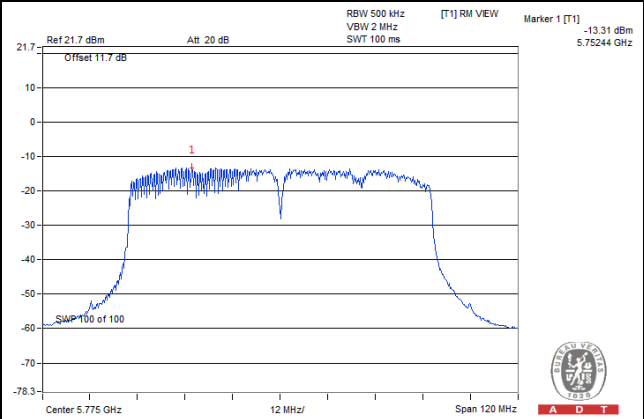

4.5 Frequency Stability

4.5.1 Limit of Frequency Stability Measurement

The frequency of the carrier signal shall be maintained within band of operation.

4.5.2 Test Setup

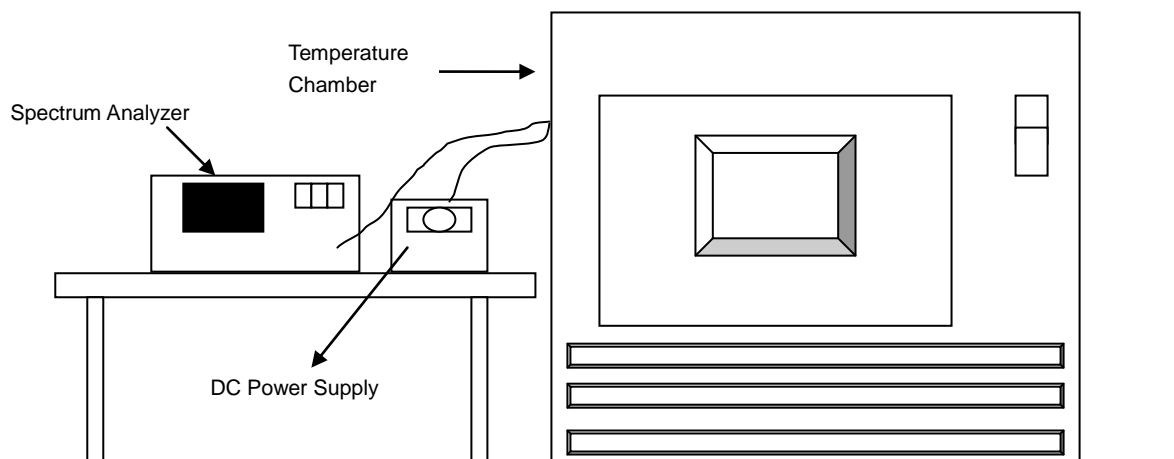

4.5.3 Test Instruments

Refer to section 4.1.3 to get information of above instrument.

4.5.4 Test Procedure

- To ensure emission at the band edge is maintained within the authorized band, those values shall be measured by radiation emissions at upper and lower frequency points, and finally compensated by frequency deviation as procedures below.
- The EUT was operated at the maximum output power, and connected to the spectrum analyzer, which is set to maximum hold function and peak detector. The peak value of the power envelope was measured and noted. The upper and lower frequency points were respectively measured relatively 10 dB lower than the measured peak value.
- The frequency deviation was calculated by adding the upper frequency point and the lower frequency point divided by two. Those detailed values of frequency deviation are provided in table below.

4.5.5 Deviation from Test Standard

No deviation.

4.5.6 EUT Operating Condition

Set the EUT transmit at un-modulation mode to test frequency stability.

4.5.7 Test Results

Frequency Stability Versus Temp.									
Operating Frequency: 5320 MHz									
Temp. (°C)	Power Supply (Vdc)	0 Minute		2 Minute		5 Minute		10 Minute	
		Measured Frequency (MHz)	Frequency Drift (ppm)	Measured Frequency (MHz)	Frequency Drift (ppm)	Measured Frequency (MHz)	Frequency Drift (ppm)	Measured Frequency (MHz)	Frequency Drift (ppm)
50	3.85	5320.029183	5.486	5320.028649	5.385	5320.028772	5.408	5320.028644	5.384
40	3.85	5320.029029	5.457	5320.028580	5.372	5320.028999	5.451	5320.028634	5.382
30	3.85	5320.030432	5.720	5320.030510	5.735	5320.029677	5.578	5320.030158	5.669
20	3.85	5320.030918	5.812	5320.030836	5.796	5320.030954	5.818	5320.030870	5.803
10	3.85	5320.032779	6.161	5320.032212	6.055	5320.032851	6.175	5320.032635	6.134
0	3.85	5320.031098	5.845	5320.031389	5.900	5320.030891	5.807	5320.031090	5.844
-10	3.85	5320.029801	5.602	5320.029686	5.580	5320.029788	5.599	5320.029780	5.598
-20	3.85	5320.029303	5.508	5320.029268	5.502	5320.029207	5.490	5320.028930	5.438
-30	3.85	5320.027896	5.244	5320.027769	5.220	5320.027754	5.217	5320.028117	5.285

Frequency Stability Versus Temp.									
Operating Frequency: 5320 MHz									
Temp. (°C)	Power Supply (Vdc)	0 Minute		2 Minute		5 Minute		10 Minute	
		Measured Frequency (MHz)	Frequency Drift (ppm)	Measured Frequency (MHz)	Frequency Drift (ppm)	Measured Frequency (MHz)	Frequency Drift (ppm)	Measured Frequency (MHz)	Frequency Drift (ppm)
20	3.70	5320.023060	4.335	5320.022729	4.272	5320.022896	4.304	5320.022784	4.283
	3.85	5320.030918	5.812	5320.030836	5.796	5320.030954	5.818	5320.030870	5.803
	4.35	5320.024661	4.636	5320.024438	4.594	5320.024451	4.596	5320.023988	4.509

4.6 6 dB Bandwidth Measurement

4.6.1 Limits of 6 dB Bandwidth Measurement

The minimum of 6 dB Bandwidth Measurement is 0.5 MHz.

4.6.2 Test Setup

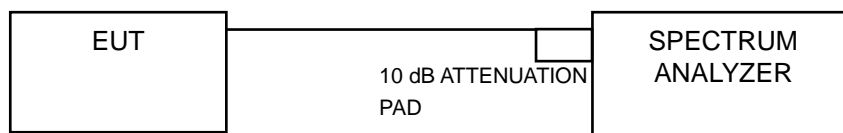

4.6.3 Test Instruments

Refer to section 4.1.3 to get information of above instrument.

4.6.4 Test Procedure

MEASUREMENT PROCEDURE REF

- Set resolution bandwidth (RBW) = 100 kHz
- Set the video bandwidth (VBW) $\geq 3 \times$ RBW, Detector = Peak.
- Trace mode = max hold.
- Sweep = auto couple.
- Measure the maximum width of the emission that is constrained by the frequencies associated with the two amplitude points (upper and lower) that are attenuated by 6 dB relative to the maximum level measured in the fundamental emission

4.6.5 Deviation from Test Standard

No deviation.

4.6.6 EUT Operating Condition

The software provided by client to enable the EUT under transmission condition continuously at lowest, middle and highest channel frequencies individually.

4.6.7 Test Results

802.11a

Channel	Frequency (MHz)	6 dB Bandwidth (MHz)	Minimum Limit (MHz)	Pass / Fail
149	5745	16.42	0.5	Pass
157	5785	16.42	0.5	Pass
165	5825	16.41	0.5	Pass

802.11n (HT20)

Channel	Frequency (MHz)	6 dB Bandwidth (MHz)	Minimum Limit (MHz)	Pass / Fail
149	5745	17.62	0.5	Pass
157	5785	17.62	0.5	Pass
165	5825	17.64	0.5	Pass

802.11n (HT40)

Channel	Frequency (MHz)	6 dB Bandwidth (MHz)	Minimum Limit (MHz)	Pass / Fail
151	5755	35.44	0.5	Pass
159	5795	35.29	0.5	Pass

802.11ac (VHT80)

Channel	Frequency (MHz)	6 dB Bandwidth (MHz)	Minimum Limit (MHz)	Pass / Fail
155	5775	75.39	0.5	Pass

Spectrum Plot of Worst Value

802.11a

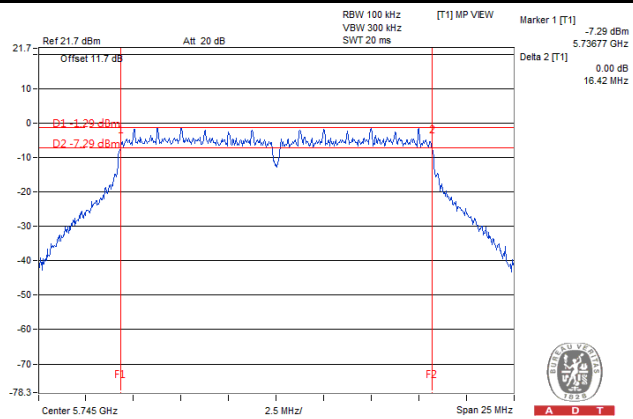

802.11n (HT20)

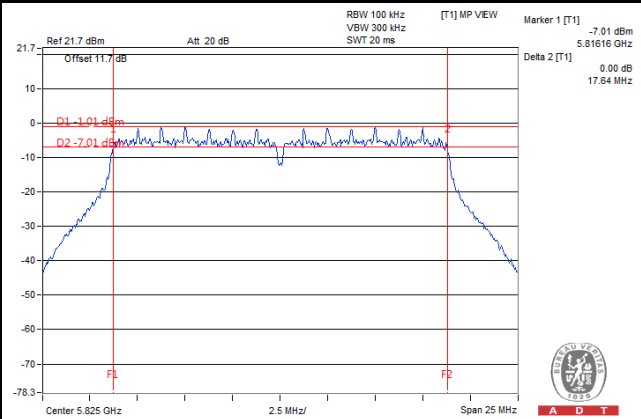

802.11n (HT40)

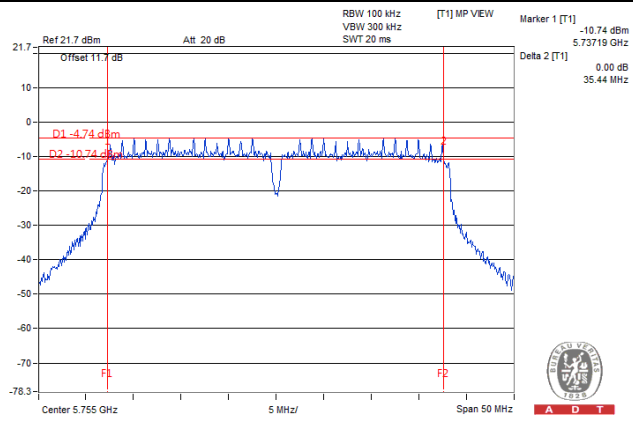

802.11ac (VHT80)

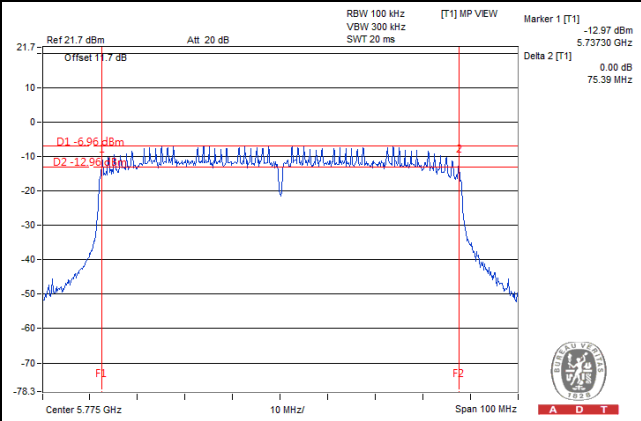



5 Pictures of Test Arrangements

Please refer to the attached file (Test Setup Photo).



A D T

Appendix – Information on the Testing Laboratories

We, Bureau Veritas Consumer Products Services (H.K.) Ltd., Taoyuan Branch, were founded in 1988 to provide our best service in EMC, Radio, Telecom and Safety consultation. Our laboratories are accredited and approved according to ISO/IEC 17025.

If you have any comments, please feel free to contact us at the following:

Linko EMC/RF Lab

Tel: 886-2-26052180

Fax: 886-2-26051924

Hsin Chu EMC/RF/Telecom Lab

Tel: 886-3-6668565

Fax: 886-3-6668323

Hwa Ya EMC/RF/Safety

Tel: 886-3-3183232

Fax: 886-3-3270892

Email: service.adt@tw.bureauveritas.com

Web Site: www.bureauveritas-adt.com

The address and road map of all our labs can be found in our web site also.

--- END ---