

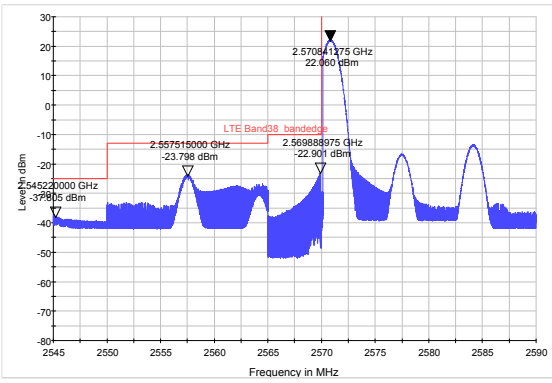

LTE Band 38 QPSK 15MHz CH-Low, RB 1

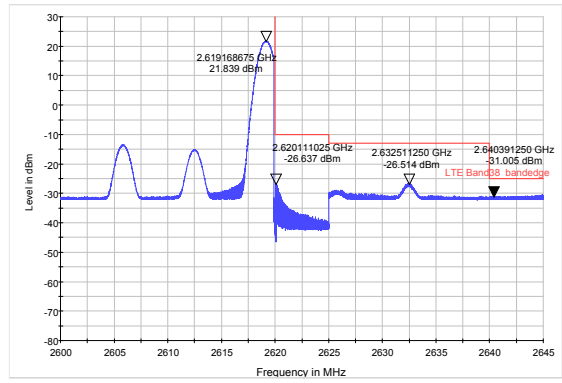

LTE Band 38 QPSK 15MHz CH-High, RB 1



LTE Band 38 QPSK 15MHz CH-Low, RB 75

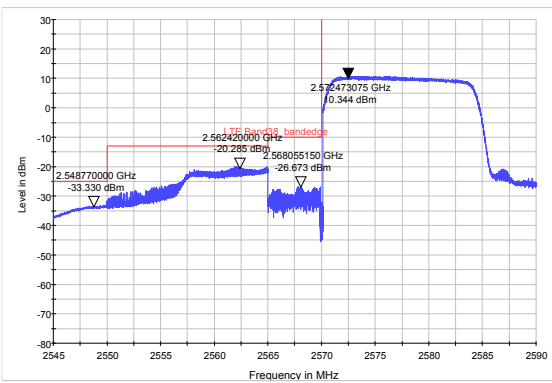

LTE Band 38 QPSK 15MHz CH-High, RB 75

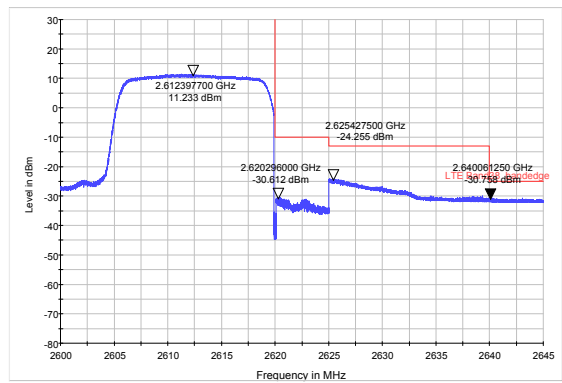

LTE Band 38 QPSK 20MHz CH-Low, RB 1

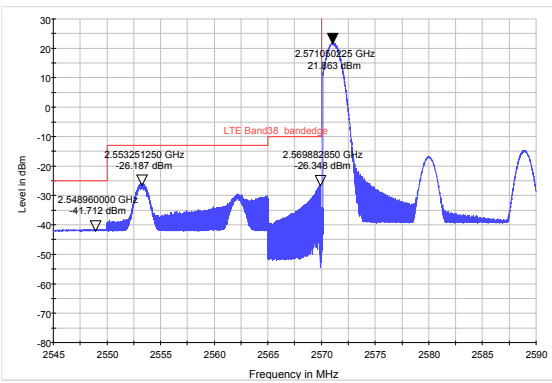

LTE Band 38 QPSK 20MHz CH-High, RB 1

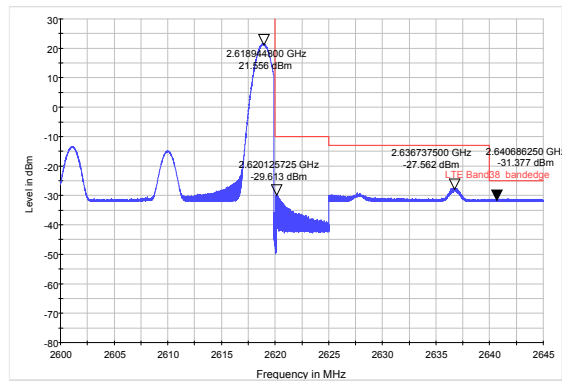

LTE Band 38 QPSK 20MHz CH-Low, RB 100

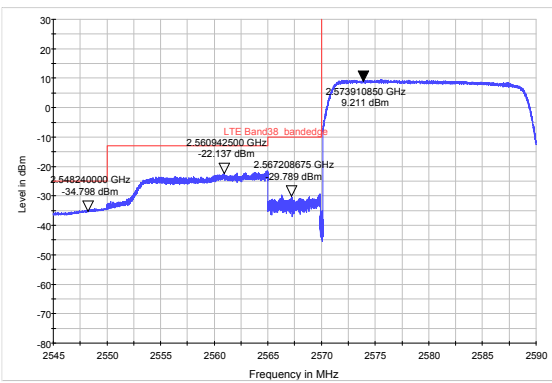

LTE Band 38 QPSK 20MHz CH-High, RB 100

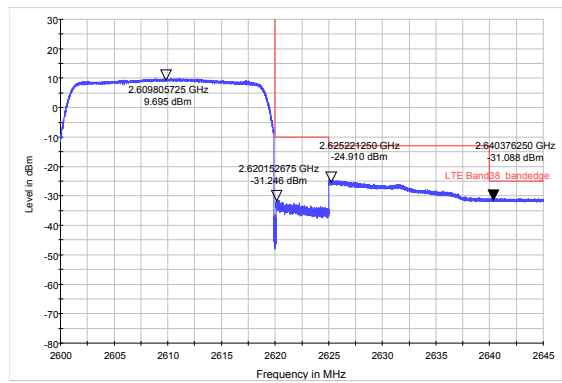



LTE Band 38 16QAM 5MHz CH-Low, RB 1

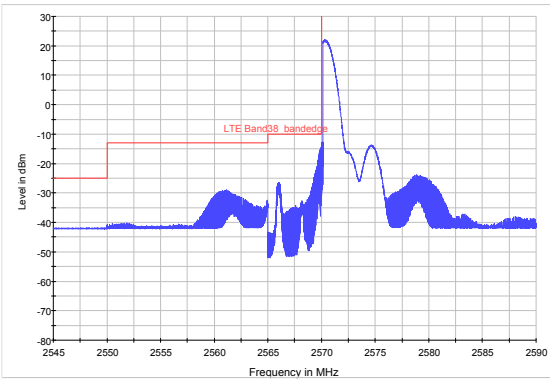

LTE Band 38 16QAM 5MHz CH-High, RB 1

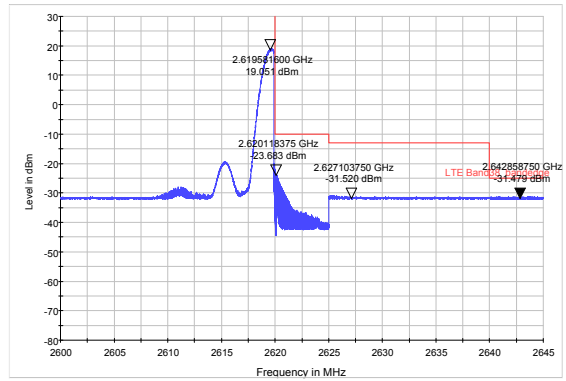

LTE Band 38 16QAM 5MHz CH-Low, RB 25

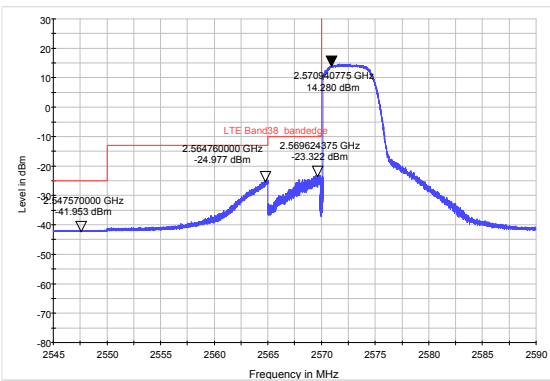

LTE Band 38 16QAM 5MHz CH-High, RB 25

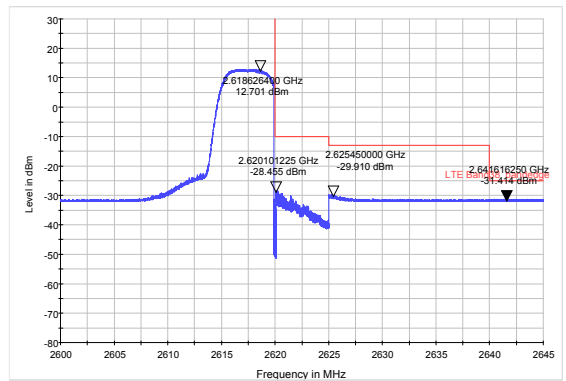

LTE Band 38 16QAM 10MHz CH-Low, RB 1

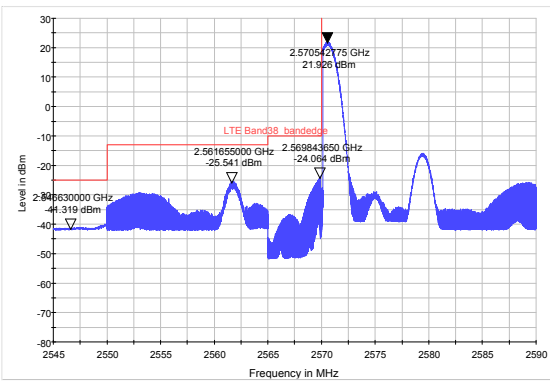

LTE Band 38 16QAM 10MHz CH-High, RB 1

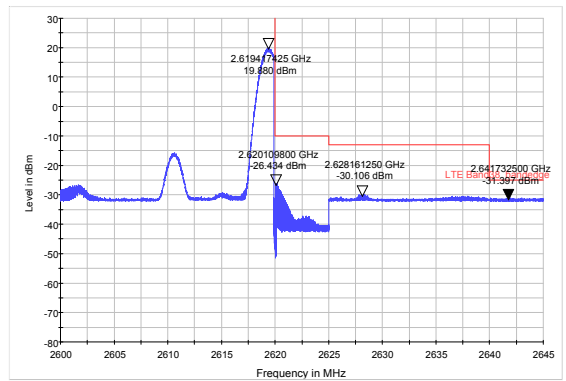

LTE Band 38 16QAM 10MHz CH-Low, RB 50

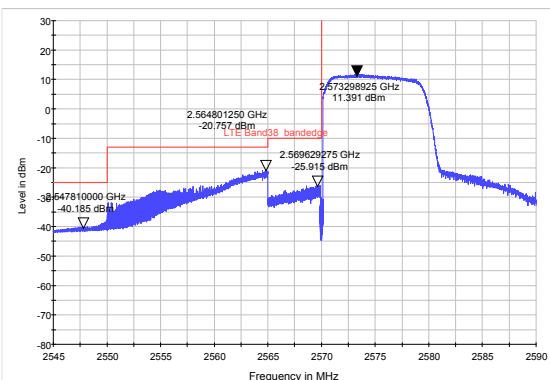

LTE Band 38 16QAM 10MHz CH-High, RB 50

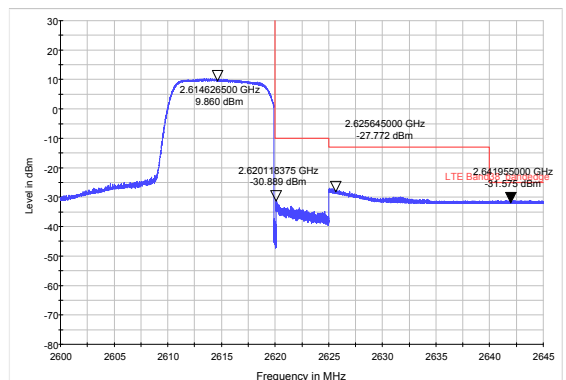



LTE Band 38 16QAM 15MHz CH-Low, RB 1

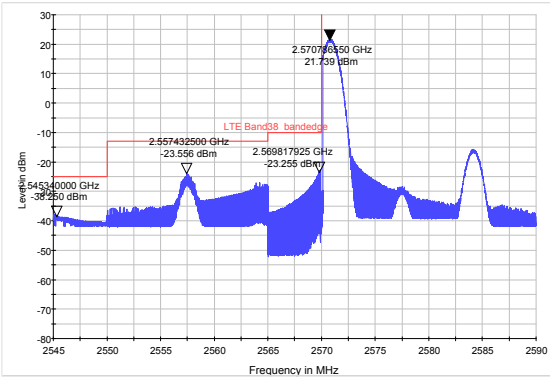

LTE Band 38 16QAM 15MHz CH-High, RB 1

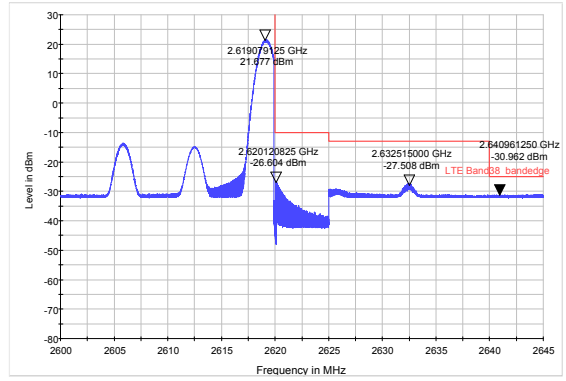

LTE Band 38 16QAM 15MHz CH-Low, RB 75

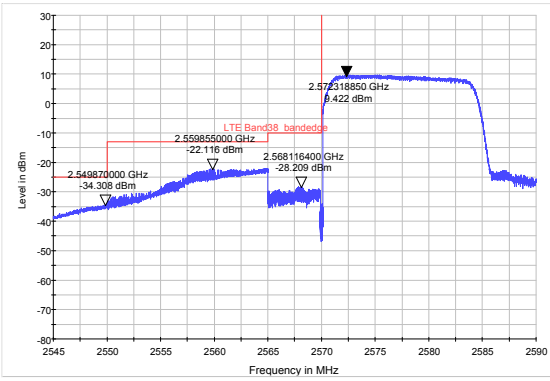

LTE Band 38 16QAM 15MHz CH-High, RB 75

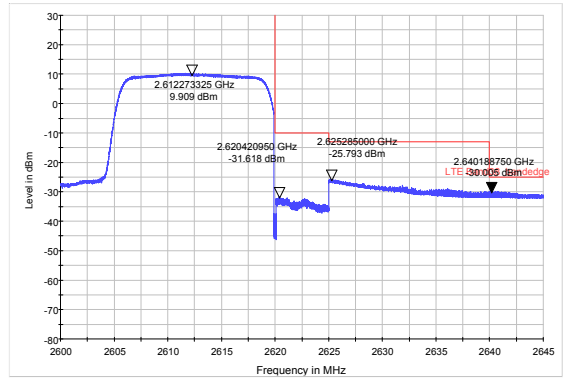

LTE Band 38 16QAM 20MHz CH-Low, RB 1

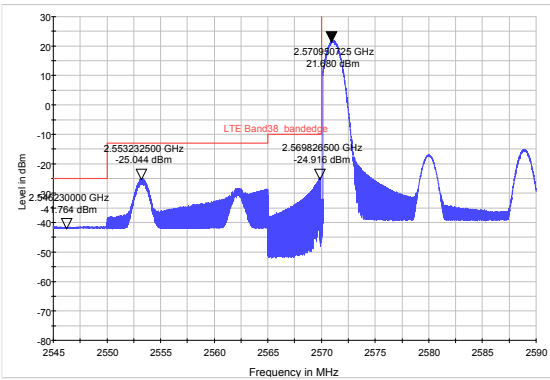

LTE Band 38 16QAM 20MHz CH-High, RB 1

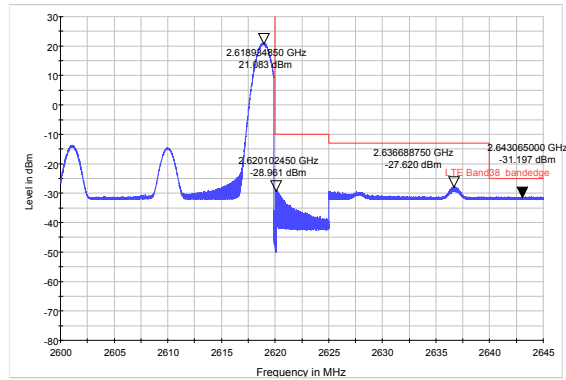

LTE Band 38 16QAM 20MHz CH-Low, RB 100

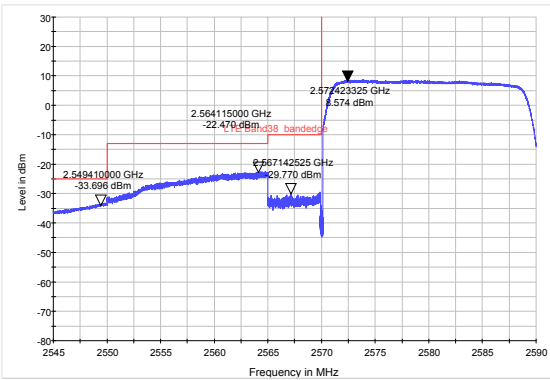

LTE Band 38 16QAM 20MHz CH-High, RB 100

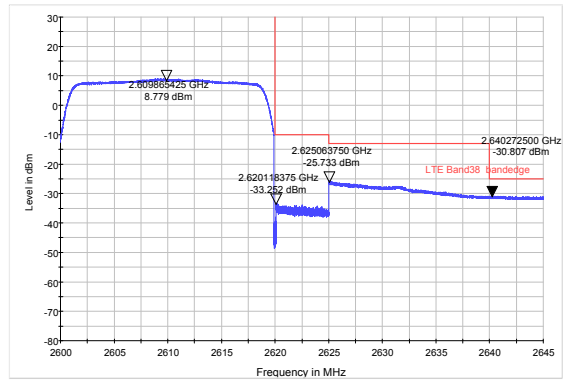

5.5 Peak-to-Average Power Ratio (PAPR)

Ambient condition

Temperature	Relative humidity	Pressure
23°C ~25°C	45%~50%	101.5kPa

Methods of Measurement

Measure the total peak power and record as PPk. And measure the total average power and record as PAvg. Both the peak and average power levels must be expressed in the same logarithmic units (e.g., dBm). Determine the PAPR from:

$$PAPR (dB) = PPk (dBm) - PAvg (dBm).$$

Test Setup

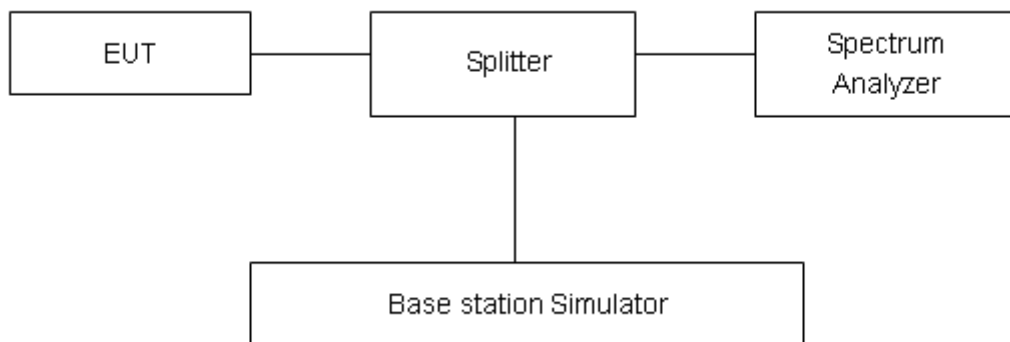

Limits

Rule Part 27.50(d)(5) Equipment employed must be authorized in accordance with the provisions of 24.51. Power measurements for transmissions by stations authorized under this section may be made either in accordance with a Commission-approved average power technique or in compliance with paragraph (d)(6) of this section. In measuring transmissions in this band using an average power technique, the peak-to-average ratio (PAR) of the transmission may not exceed 13 dB.

Measurement Uncertainty

The assessed measurement uncertainty to ensure 95% confidence level for the normal distribution is with the coverage factor k = 2, U= 0.4 dB.

Test Results

LTE Band 4								
Modulation	Bandwidth (MHz)	Channel	Frequency (MHz)	Peak (dBm)	Avg (dBm)	PAPR (dB)	Limit (dB)	Conclusion
QPSK	1.4	19957	1710.7	25.27	22.11	3.16	≤13	PASS
		20175	1732.5	27.52	22.58	4.94	≤13	PASS
		20393	1754.3	26.90	22.38	4.52	≤13	PASS
	3	19965	1711.5	25.95	22.14	3.81	≤13	PASS
		20175	1732.5	27.63	22.62	5.01	≤13	PASS
		20385	1753.5	27.14	22.41	4.73	≤13	PASS
	5	19975	1712.5	25.95	22.12	3.83	≤13	PASS
		20175	1732.5	27.58	22.61	4.97	≤13	PASS
		20375	1752.5	26.96	22.39	4.57	≤13	PASS
	10	20000	1715	26.37	22.20	4.17	≤13	PASS
		20175	1732.5	27.56	22.63	4.93	≤13	PASS
		20350	1750	26.90	22.43	4.47	≤13	PASS
	15	20025	1717.5	26.79	22.18	4.61	≤13	PASS
		20175	1732.5	27.57	22.59	4.98	≤13	PASS
		20325	1747.5	26.83	22.38	4.45	≤13	PASS
20	20050	1720	26.95	22.15	4.80	≤13	PASS	
	20175	1732.5	27.33	22.54	4.79	≤13	PASS	
	20300	1745	26.82	22.34	4.48	≤13	PASS	
16QAM	1.4	19957	1710.7	25.03	21.05	3.98	≤13	PASS
		20175	1732.5	27.10	21.27	5.83	≤13	PASS
		20393	1754.3	26.94	21.53	5.41	≤13	PASS
	3	19965	1711.5	25.53	21.08	4.45	≤13	PASS
		20175	1732.5	27.19	21.31	5.88	≤13	PASS
		20385	1753.5	27.16	21.56	5.60	≤13	PASS
	5	19975	1712.5	25.69	21.06	4.63	≤13	PASS
		20175	1732.5	27.04	21.27	5.77	≤13	PASS
		20375	1752.5	26.93	21.51	5.42	≤13	PASS
	10	20000	1715	26.03	21.09	4.94	≤13	PASS
		20175	1732.5	27.10	21.32	5.78	≤13	PASS
		20350	1750	26.80	21.55	5.25	≤13	PASS
	15	20025	1717.5	26.51	21.06	5.45	≤13	PASS
		20175	1732.5	27.00	21.27	5.73	≤13	PASS
		20325	1747.5	26.78	21.51	5.27	≤13	PASS
20	20050	1720	26.70	21.04	5.66	≤13	PASS	
	20175	1732.5	26.91	21.23	5.68	≤13	PASS	
	20300	1745	26.82	21.48	5.34	≤13	PASS	

LTE Band 7								
Modulation	Bandwidth (MHz)	Channel	Frequency (MHz)	Peak (dBm)	Avg (dBm)	PAPR (dB)	Limit (dB)	Conclusion
QPSK	5	20775	2502.5	25.61	20.65	4.96	≤13	PASS
		21100	2535	25.95	20.99	4.96	≤13	PASS
		21425	2567.5	25.79	21.05	4.74	≤13	PASS
	10	20800	2505	25.72	20.73	4.99	≤13	PASS
		21100	2535	26.00	21.01	4.99	≤13	PASS
		21400	2565	25.84	21.09	4.75	≤13	PASS
	15	20825	2507.5	25.72	20.71	5.01	≤13	PASS
		21100	2535	26.02	20.97	5.05	≤13	PASS
		21375	2562.5	25.79	21.04	4.75	≤13	PASS
	20	20850	2510	26.37	21.36	5.01	≤13	PASS
		21100	2535	26.49	21.32	5.17	≤13	PASS
		21350	2560	26.29	21.33	4.96	≤13	PASS
16QAM	5	20775	2502.5	25.90	20.05	5.85	≤13	PASS
		21100	2535	26.01	20.17	5.84	≤13	PASS
		21425	2567.5	25.79	20.24	5.55	≤13	PASS
	10	20800	2505	25.95	20.08	5.87	≤13	PASS
		21100	2535	26.06	20.22	5.84	≤13	PASS
		21400	2565	25.93	20.28	5.65	≤13	PASS
	15	20825	2507.5	25.56	20.05	5.51	≤13	PASS
		21100	2535	26.04	20.17	5.87	≤13	PASS
		21375	2562.5	25.83	20.24	5.59	≤13	PASS
	20	20850	2510	25.94	20.03	5.91	≤13	PASS
		21100	2535	26.05	20.13	5.92	≤13	PASS
		21350	2560	25.97	20.21	5.76	≤13	PASS

LTE Band 38								
Modulation	Bandwidth ((MHz))	Channel	Frequency (MHz)	Peak (dBm)	Avg (dBm)	PAPR (dB)	Limit (dB)	Conclusion
QPSK	5	37775	2572.5	30.54	21.64	8.90	≤13	PASS
		38000	2595	31.29	21.82	9.47	≤13	PASS
		38225	2617.5	30.92	21.63	9.29	≤13	PASS
	10	37800	2575	30.45	21.72	8.73	≤13	PASS
		38000	2595	30.46	21.84	8.62	≤13	PASS
		38200	2615	30.13	21.67	8.46	≤13	PASS
	15	37825	2577.5	30.92	21.70	9.22	≤13	PASS
		38000	2595	30.61	21.80	8.81	≤13	PASS
		38175	2612.5	31.34	21.62	9.72	≤13	PASS
	20	37850	2580	30.66	21.67	8.99	≤13	PASS
		38000	2595	30.88	21.75	9.13	≤13	PASS
		38150	2610	30.78	21.58	9.20	≤13	PASS
16QAM	5	37775	2572.5	30.32	20.67	9.65	≤13	PASS
		38000	2595	30.50	20.77	9.73	≤13	PASS
		38225	2617.5	30.09	20.73	9.36	≤13	PASS
	10	37800	2575	30.57	20.70	9.87	≤13	PASS
		38000	2595	30.80	20.82	9.98	≤13	PASS
		38200	2615	30.53	20.77	9.76	≤13	PASS
	15	37825	2577.5	30.62	20.67	9.95	≤13	PASS
		38000	2595	30.75	20.77	9.98	≤13	PASS
		38175	2612.5	30.55	20.73	9.82	≤13	PASS
	20	37850	2580	30.18	20.65	9.53	≤13	PASS
		38000	2595	30.22	20.73	9.49	≤13	PASS
		38150	2610	30.97	20.70	10.27	≤13	PASS

5.6 Frequency Stability

Ambient condition

Temperature	Relative humidity	Pressure
23°C ~25°C	45%~50%	101.5kPa

Method of Measurement

1. Frequency Stability (Temperature Variation)

The temperature inside the climate chamber is varied from -30°C to +55°C in 10°C step size.

(1)With all power removed, the temperature was decreased to -10°C and permitted to stabilize for three hours.

(2)Measure the carrier frequency with the test equipment in a “call mode”. These measurements should be made within 1 minute of powering up the mobile station, to prevent significant self warming.

(3) Repeat the above measurements at 10°C increments from -30°C to +55°C. Allow at least 1.5 hours at each temperature, un-powered, before making measurements.

2. Frequency Stability (Voltage Variation)

The frequency stability shall be measured with variation of primary supply voltage as follows:

(1) Vary primary supply voltage from 85 to 115 percent of the nominal value for other than hand carried battery equipment.

(2) For hand carried, battery powered equipment, reduce primary supply voltage to the battery-operating end point which shall be specified by the manufacturer.

This transceiver is specified to operate with an input voltage of between 3.65 V and 4.4 V, with a nominal voltage of 3.85V.

Test setup

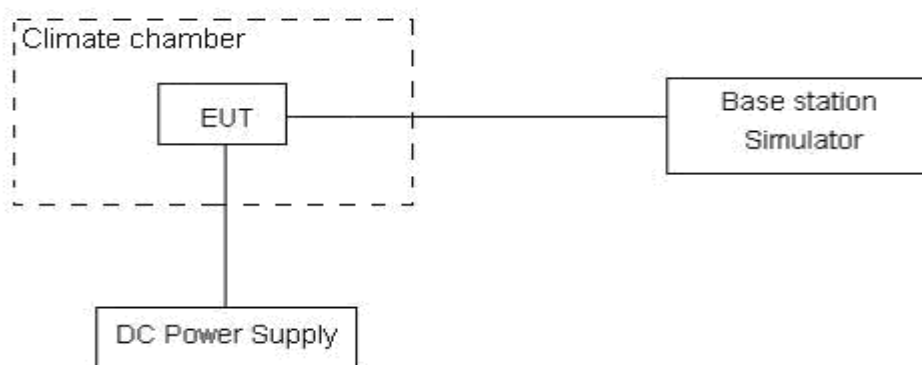

Limits

No specific frequency stability requirements in part 27.54

Measurement Uncertainty

The assessed measurement uncertainty to ensure 99.75% confidence level for the normal distribution is with the coverage factor $k = 3, U=0.01\text{ppm}$.

Test Result

Bandwidth	Test status	LTE Band 4 Channel 20175 Test Results (ppm)	
		QPSK	16QAM
1.4MHz	-30°C/Normal Voltage	0.00156	0.00092
	-20°C/Normal Voltage	-0.00126	0.00023
	-10°C/Normal Voltage	0.00043	-0.00023
	0°C/Normal Voltage	-0.00274	0.00125
	10°C/Normal Voltage	-0.00069	-0.00177
	20°C/Normal Voltage	-0.00136	-0.00086
	30°C/Normal Voltage	0.00025	-0.00215
	40°C/Normal Voltage	-0.00326	0.00044
	50°C/Normal Voltage	0.00036	0.00031
	55°C/Normal Voltage	0.00048	0.00045
	20°C/Min Voltage	-0.00044	0.00069
	20°C/Max Voltage	-0.00311	-0.00147
3MHz	-30°C/Normal Voltage	-0.00072	-0.00201
	-20°C/Normal Voltage	0.00027	-0.00173
	-10°C/Normal Voltage	-0.00224	-0.00086
	0°C/Normal Voltage	-0.00065	-0.00006
	10°C/Normal Voltage	0.00021	0.00147
	20°C/Normal Voltage	0.00072	0.00154
	30°C/Normal Voltage	0.00054	-0.00169
	40°C/Normal Voltage	-0.00020	-0.00065
	50°C/Normal Voltage	-0.00241	-0.00180
	55°C/Normal Voltage	-0.00245	-0.00126
	20°C/Min Voltage	-0.00145	-0.00170
	20°C/Max Voltage	-0.00008	-0.00216
5MHz	-30°C/Normal Voltage	-0.00119	-0.00158
	-20°C/Normal Voltage	-0.00068	-0.00050
	-10°C/Normal Voltage	-0.00057	-0.00190
	0°C/Normal Voltage	-0.00010	0.00122
	10°C/Normal Voltage	-0.00072	-0.00189
	20°C/Normal Voltage	-0.00036	-0.00029
	30°C/Normal Voltage	-0.00075	-0.00021
	40°C/Normal Voltage	-0.00090	-0.00145
	50°C/Normal Voltage	0.00001	-0.00008
	55°C/Normal Voltage	0.00048	0.00025
	20°C/Min Voltage	0.00137	0.00078
	20°C/Max Voltage	0.00021	0.00085



10MHz	-30°C/Normal Voltage	0.00048	-0.00210
	-20°C/Normal Voltage	-0.00094	-0.00039
	-10°C/Normal Voltage	0.00032	-0.00001
	0°C/Normal Voltage	-0.00053	-0.00034
	10°C/Normal Voltage	-0.00048	-0.00180
	20°C/Normal Voltage	0.00332	-0.00083
	30°C/Normal Voltage	0.00150	0.00054
	40°C/Normal Voltage	-0.00110	0.00113
	50°C/Normal Voltage	-0.00146	0.00077
	55°C/Normal Voltage	-0.00180	0.00124
	20°C/Min Voltage	-0.00002	-0.00072
	20°C/Max Voltage	-0.00286	-0.00214
15MHz	-30°C/Normal Voltage	0.00079	-0.00082
	-20°C/Normal Voltage	0.00210	0.00058
	-10°C/Normal Voltage	0.00125	-0.00006
	0°C/Normal Voltage	-0.00040	0.00046
	10°C/Normal Voltage	0.00029	0.00014
	20°C/Normal Voltage	0.00076	0.00154
	30°C/Normal Voltage	0.00069	-0.00125
	40°C/Normal Voltage	-0.00077	0.00038
	50°C/Normal Voltage	0.00043	0.00181
	55°C/Normal Voltage	0.00050	0.00057
	20°C/Min Voltage	-0.00192	0.00001
	20°C/Max Voltage	-0.00163	-0.00002
20MHz	-30°C/Normal Voltage	0.00036	0.00028
	-20°C/Normal Voltage	0.00012	-0.00225
	-10°C/Normal Voltage	-0.00066	-0.00072
	0°C/Normal Voltage	0.00014	0.00149
	10°C/Normal Voltage	-0.00080	0.00083
	20°C/Normal Voltage	-0.00106	0.00228
	30°C/Normal Voltage	-0.00208	-0.00144
	40°C/Normal Voltage	-0.00052	-0.00233
	50°C/Normal Voltage	-0.00017	-0.00124
	55°C/Normal Voltage	-0.00024	-0.00165
	20°C/Min Voltage	0.00316	-0.00254
	20°C/Max Voltage	0.00177	0.00192

Bandwidth	Test status	LTE Band 7 Channel 21100 Test Results (ppm)	
		QPSK	16QAM
5MHz	-30°C/Normal Voltage	-0.00272	-0.00170
	-20°C/Normal Voltage	-0.00239	-0.00024
	-10°C/Normal Voltage	-0.00230	-0.00296
	0°C/Normal Voltage	-0.00030	0.00119
	10°C/Normal Voltage	-0.00290	-0.00074
	20°C/Normal Voltage	-0.00172	0.00021
	30°C/Normal Voltage	-0.00144	-0.00035
	40°C/Normal Voltage	-0.00202	-0.00320
	50°C/Normal Voltage	-0.00202	-0.00215
	55°C/Normal Voltage	-0.00167	-0.00147
	20°C/Min Voltage	-0.00193	-0.00122
	20°C/Max Voltage	-0.00361	-0.00271
10MHz	-30°C/Normal Voltage	-0.00183	-0.00229
	-20°C/Normal Voltage	-0.00077	-0.00096
	-10°C/Normal Voltage	0.00114	-0.00215
	0°C/Normal Voltage	-0.00173	-0.00157
	10°C/Normal Voltage	-0.00123	-0.00158
	20°C/Normal Voltage	-0.00078	-0.00219
	30°C/Normal Voltage	-0.00089	-0.00150
	40°C/Normal Voltage	-0.00189	-0.00103
	50°C/Normal Voltage	-0.00203	-0.00145
	55°C/Normal Voltage	0.00118	0.00166
	20°C/Min Voltage	-0.00036	-0.00203
	20°C/Max Voltage	-0.00286	-0.00312
15MHz	-30°C/Normal Voltage	-0.00254	-0.00099
	-20°C/Normal Voltage	-0.00179	-0.00048
	-10°C/Normal Voltage	-0.00386	-0.00017
	0°C/Normal Voltage	-0.00214	0.00039
	10°C/Normal Voltage	-0.00253	-0.00227
	20°C/Normal Voltage	-0.00236	-0.00267
	30°C/Normal Voltage	-0.00307	-0.00306
	40°C/Normal Voltage	-0.00013	-0.00043
	50°C/Normal Voltage	-0.00224	-0.00272
	55°C/Normal Voltage	0.00166	0.00202
	20°C/Min Voltage	-0.00265	-0.00187
	20°C/Max Voltage	-0.00005	0.00000
20MHz	-30°C/Normal Voltage	-0.00282	-0.00288



	-20°C/Normal Voltage	-0.00138	-0.00236
	-10°C/Normal Voltage	-0.00237	-0.00324
	0°C/Normal Voltage	-0.00110	-0.00266
	10°C/Normal Voltage	-0.00132	-0.00215
	20°C/Normal Voltage	-0.00070	-0.00174
	30°C/Normal Voltage	0.00055	-0.00178
	40°C/Normal Voltage	-0.00234	-0.00126
	50°C/Normal Voltage	-0.00270	-0.00045
	55°C/Normal Voltage	0.00070	0.00065
	20°C/Min Voltage	-0.00124	-0.00150
	20°C/Max Voltage	-0.00092	-0.00349

Bandwidth	Test status	LTE Band 38 Channel 38000 Test Results (ppm)	
		QPSK	16QAM
5MHz	-30°C/Normal Voltage	-0.00214	0.00299
	-20°C/Normal Voltage	0.00069	0.00476
	-10°C/Normal Voltage	0.00432	0.00113
	0°C/Normal Voltage	0.00405	-0.00217
	10°C/Normal Voltage	-0.00002	-0.00277
	20°C/Normal Voltage	-0.00106	0.00488
	30°C/Normal Voltage	0.00281	0.00087
	40°C/Normal Voltage	0.00369	0.00414
	50°C/Normal Voltage	0.00227	0.00155
	55°C/Normal Voltage	0.00306	0.00110
	20°C/Min Voltage	0.00021	0.00348
	20°C/Max Voltage	0.00124	0.00225
10MHz	-30°C/Normal Voltage	0.00247	0.00221
	-20°C/Normal Voltage	-0.00015	-0.00178
	-10°C/Normal Voltage	0.00121	-0.00082
	0°C/Normal Voltage	0.00036	0.00192
	10°C/Normal Voltage	0.00224	0.00098
	20°C/Normal Voltage	0.00054	0.00221
	30°C/Normal Voltage	0.00283	-0.00209
	40°C/Normal Voltage	0.00158	-0.00012
	50°C/Normal Voltage	0.00393	0.00082
	55°C/Normal Voltage	0.00197	0.00166
	20°C/Min Voltage	0.00210	0.00340
	20°C/Max Voltage	-0.00128	-0.00039



15MHz	-30°C/Normal Voltage	0.00219	0.00385
	-20°C/Normal Voltage	-0.00128	0.00248
	-10°C/Normal Voltage	0.00035	0.00232
	0°C/Normal Voltage	0.00315	0.00286
	10°C/Normal Voltage	0.00273	0.00108
	20°C/Normal Voltage	0.00087	0.00122
	30°C/Normal Voltage	-0.00179	0.00413
	40°C/Normal Voltage	-0.00049	0.00342
	50°C/Normal Voltage	0.00145	0.00172
	55°C/Normal Voltage	0.00082	0.00176
	20°C/Min Voltage	-0.00042	0.00289
	20°C/Max Voltage	0.00071	0.00315
	20MHz	-30°C/Normal Voltage	0.00157
-20°C/Normal Voltage		0.00222	0.00279
-10°C/Normal Voltage		0.00119	0.00077
0°C/Normal Voltage		-0.00042	0.00300
10°C/Normal Voltage		0.00180	-0.00047
20°C/Normal Voltage		0.00457	0.00100
30°C/Normal Voltage		0.00200	0.00281
40°C/Normal Voltage		0.00215	0.00349
50°C/Normal Voltage		0.00184	0.00328
55°C/Normal Voltage		0.00149	0.00269
20°C/Min Voltage		0.00361	0.00104
20°C/Max Voltage		0.00241	0.00241

5.7 Spurious Emissions at Antenna Terminals

Ambient condition

Temperature	Relative humidity	Pressure
23°C ~25°C	45%~50%	101.5kPa

Method of Measurement

The EUT was connected to Spectrum Analyzer and Base Station Simulator via power Splitter. The measurement is carried out using a spectrum analyzer. The spectrum analyzer scans from 30MHz to the 10th harmonic of the carrier. The peak detector is used. Set RBW 1MHz and VBW3MHz, Sweep is set to ATUO.

Of those disturbances below (limit – 20 dB), the mark is not required for the EUT.

Test setup

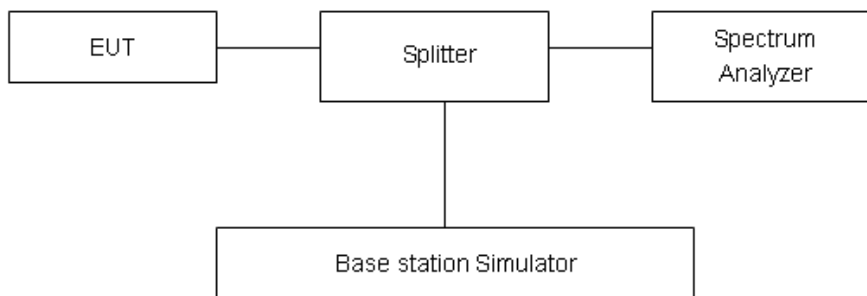

Limits

Rule Part 27.53(h) specifies that “for operations in the 1695-1710 MHz, 1710-1755 MHz, 1755-1780 MHz, 1915-1920 MHz, 1995-2000 MHz, 2000-2020 MHz, 2110-2155 MHz, 2155-2180 MHz, and 2180-2200 bands, the power of any emission outside a licensee's frequency block shall be attenuated below the transmitter power (P) in watts by at least $43 + 10 \log_{10}(P)$ dB..”

Rule Part 27.53(m) $55 + 10 \log(P)$ dB on all frequencies more than X megahertz from the channel edge, where X is the greater of 6 megahertz or the actual emission bandwidth as defined in paragraph (m)(4) of this section.

Part 27.53(h) Limit	-13 dBm
Part 27.53(m) Limit	-25 dBm

Measurement Uncertainty

The assessed measurement uncertainty to ensure 99.75% confidence level for the normal



distribution is with the coverage factor $k = 1.96$.

Frequency	Uncertainty
100kHz-2GHz	0.684 dB
2GHz-12.75GHz	1.407 dB

Test Result: PASS

If disturbances were found more than 20dB below limit line, the mark is not required for the EUT.
The signal beyond the limit is carrier in the following plots.

LTE Band 4 1.4MHz CH-Low 30MHz~3GHz

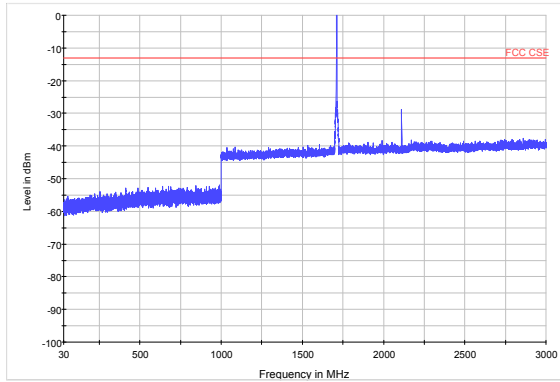

LTE Band 4 1.4MHz CH-Low 3GHz~18GHz

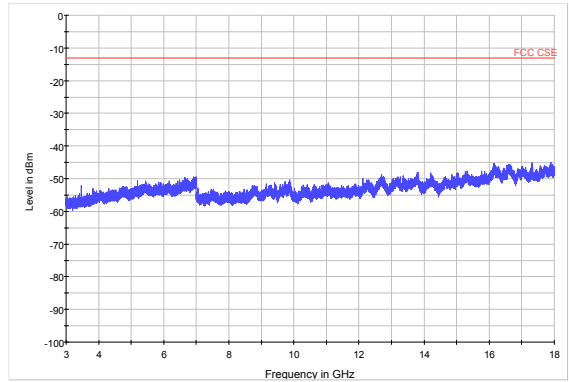

LTE Band 4 1.4MHz CH-Middle 30MHz~3GHz

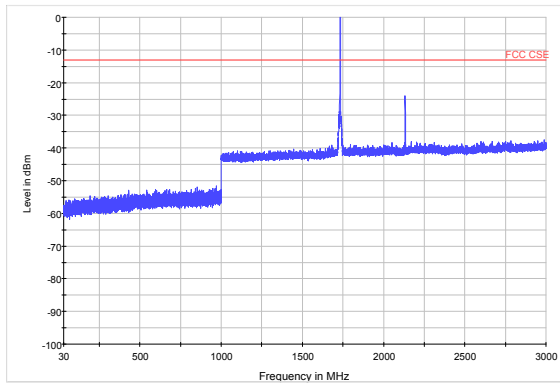

LTE Band 4 1.4MHz CH-Middle 3GHz~18GHz

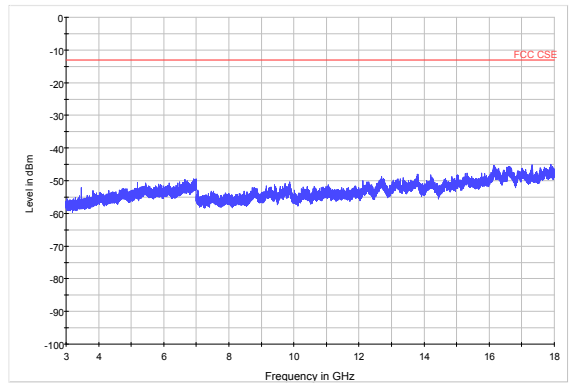

LTE Band 4 1.4MHz CH-High 30MHz~3GHz

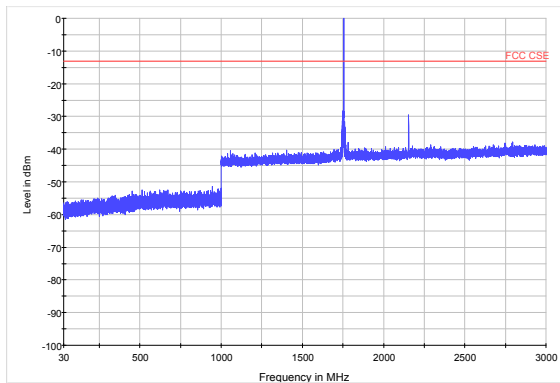

LTE Band 4 1.4MHz CH-High 3GHz~18GHz

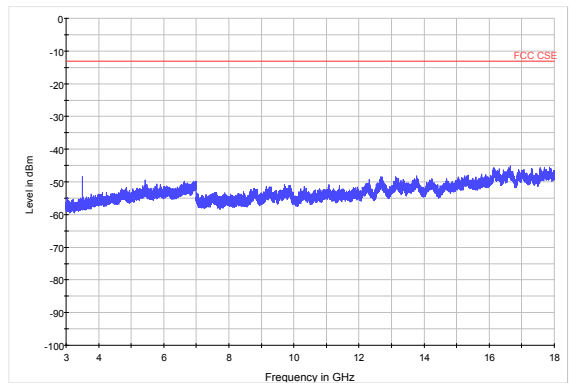



LTE Band 4 3MHz CH-Low 30MHz~3GHz

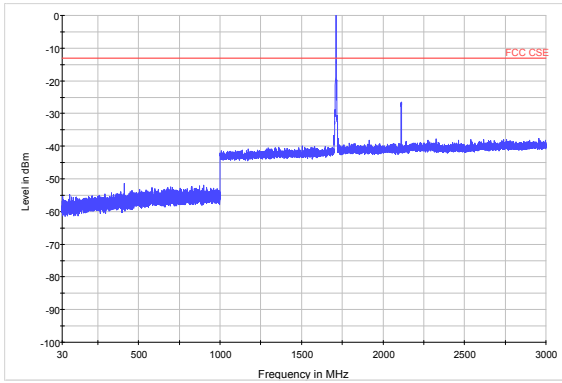

LTE Band 4 3MHz CH-Low 3GHz~18GHz

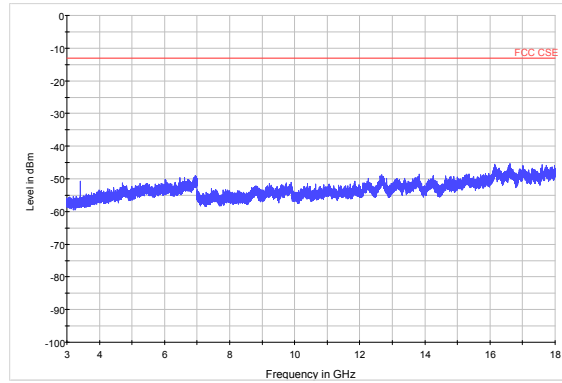

LTE Band 4 3MHz CH-Middle 30MHz~3GHz

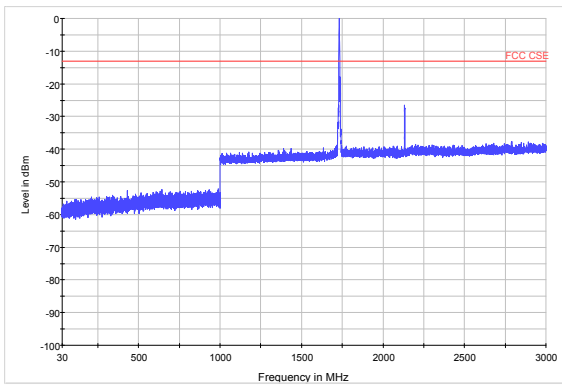

LTE Band 4 3MHz CH-Middle 3GHz~18GHz

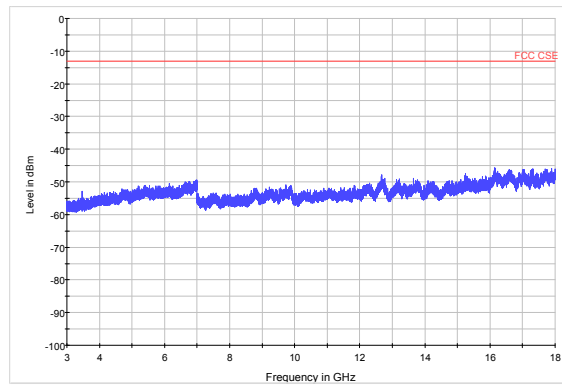

LTE Band 4 3MHz CH-High 30MHz~3GHz

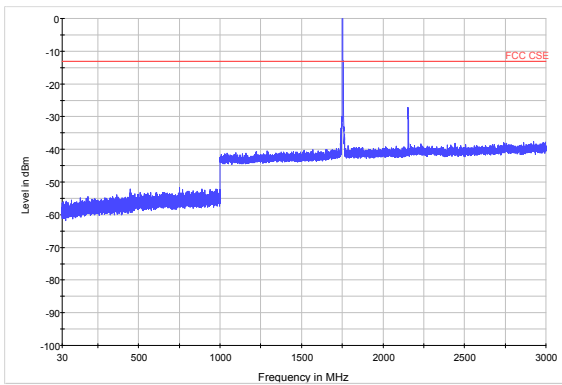

LTE Band 4 3MHz CH-High 3GHz~18GHz

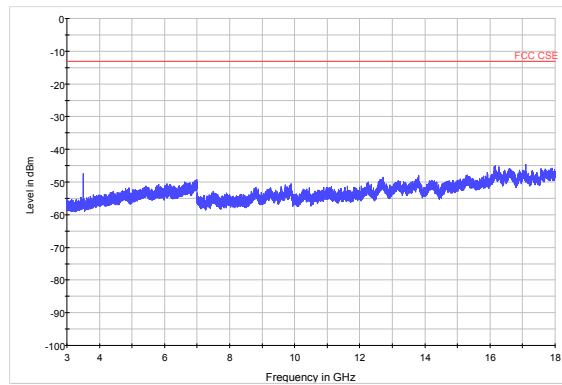



LTE Band 4 5MHz CH-Low 30MHz~3GHz

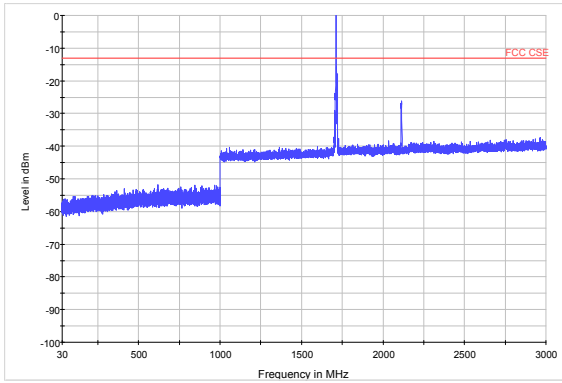

LTE Band 4 5MHz CH-Low 3GHz~18GHz

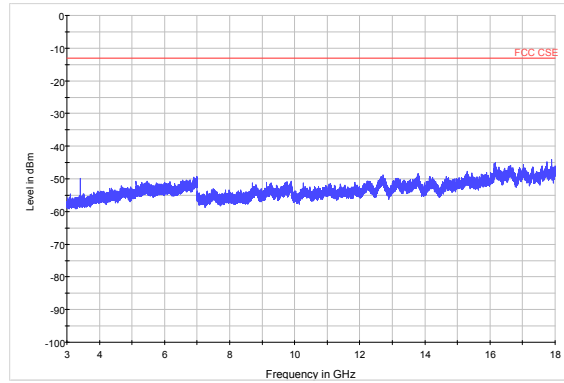

LTE Band 4 5MHz CH-Middle 30MHz~3GHz

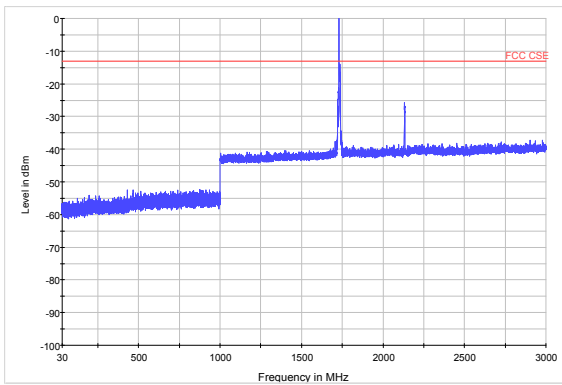

LTE Band 4 5MHz CH-Middle 3GHz~18GHz

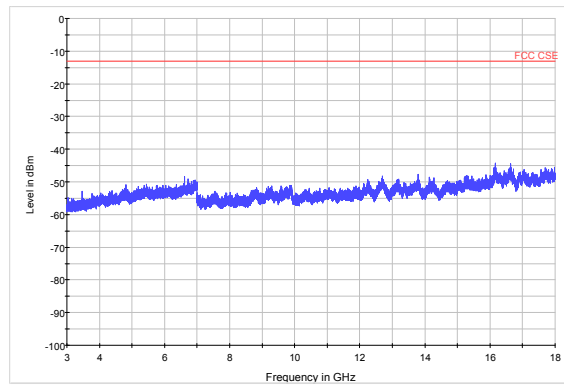

LTE Band 4 5MHz CH-High 30MHz~3GHz

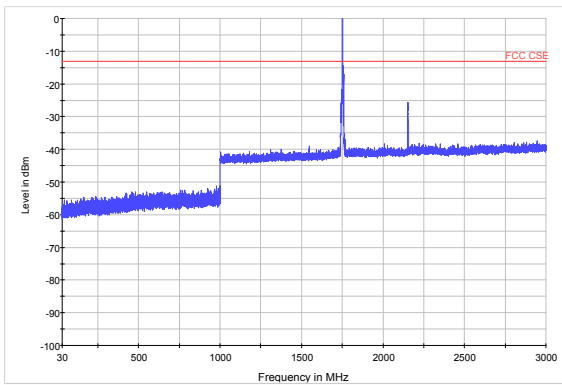

LTE Band 4 5MHz CH-High 3GHz~18GHz

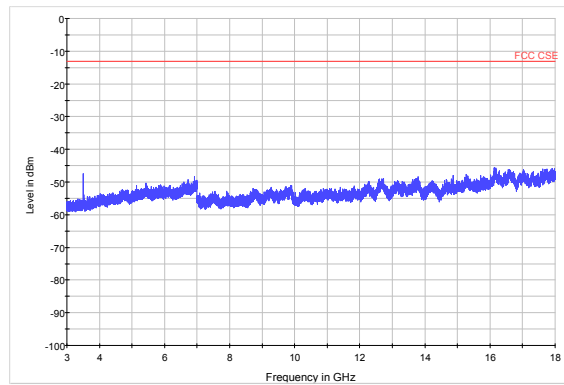



LTE Band 4 10MHz CH-Low 30MHz~3GHz

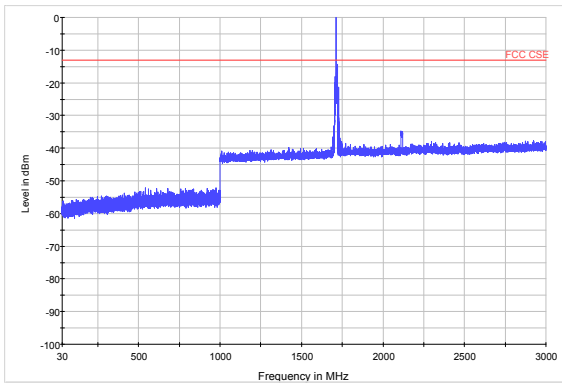

LTE Band 4 10MHz CH-Low 3GHz~18GHz

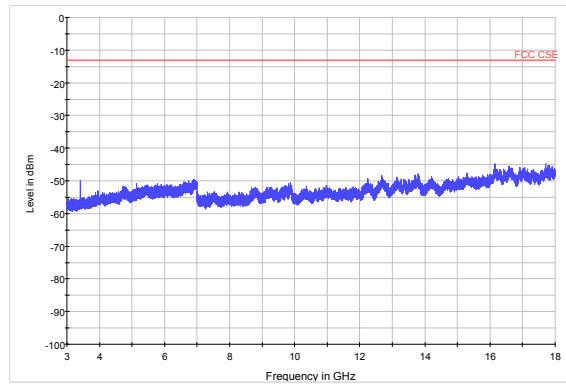

LTE Band 4 10MHz CH-Middle 30MHz~3GHz

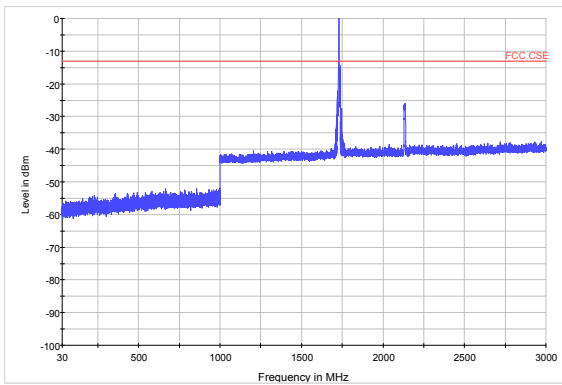

LTE Band 4 10MHz CH-Middle 3GHz~18GHz

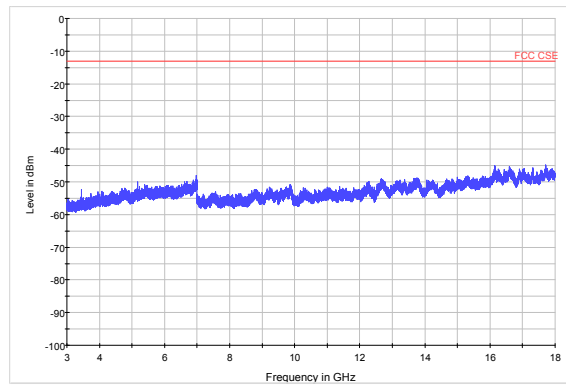

LTE Band 4 10MHz CH-High 30MHz~3GHz

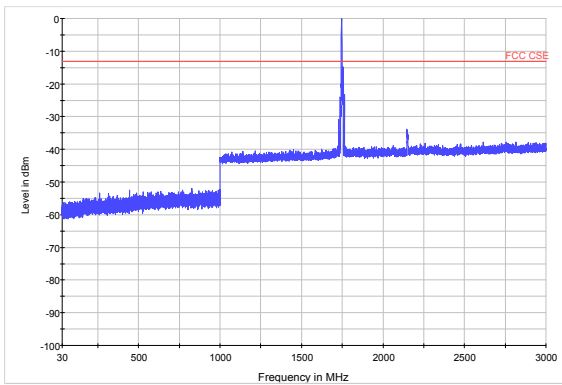

LTE Band 4 10MHz CH-High 3GHz~18GHz

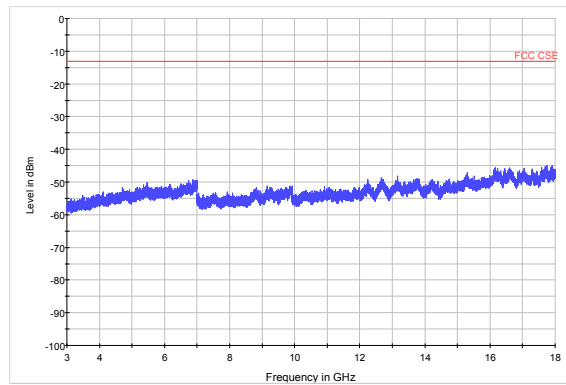



LTE Band 4 15MHz CH-Low 30MHz~3GHz

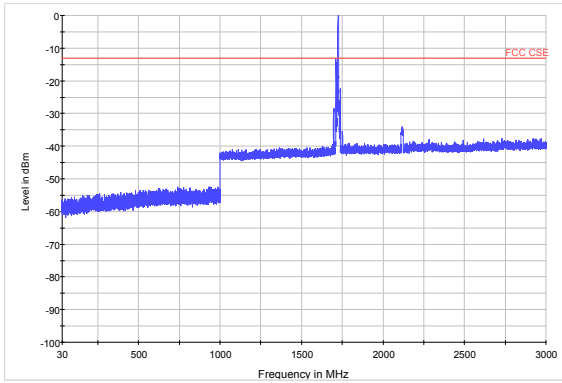

LTE Band 4 15MHz CH-Low 3GHz~18GHz

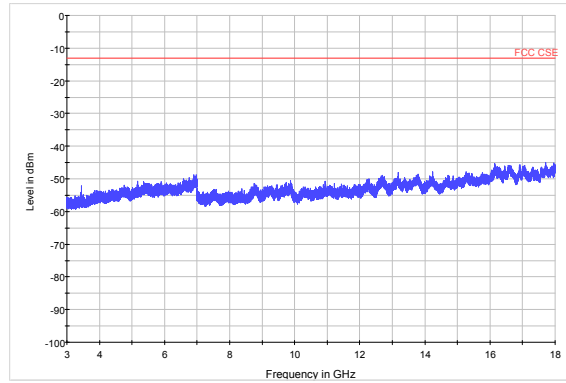

LTE Band 4 15MHz CH-Middle 30MHz~3GHz

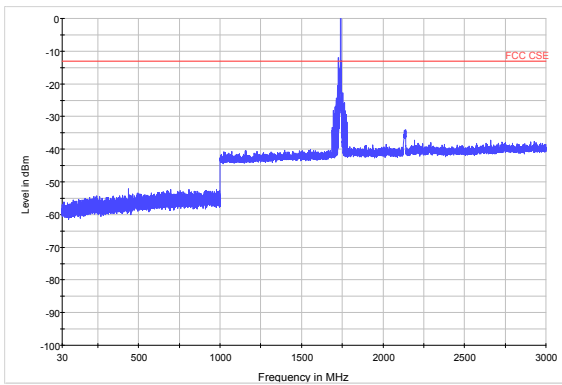

LTE Band 4 15MHz CH-Middle 3GHz~18GHz

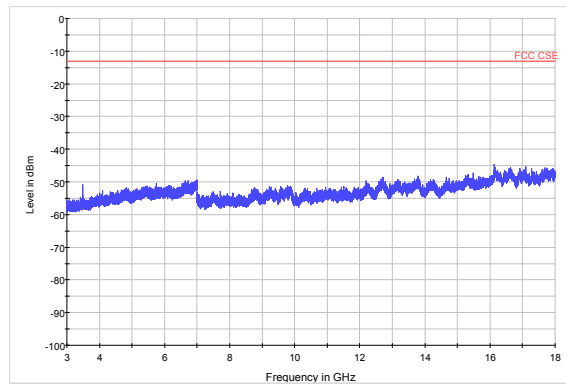

LTE Band 4 15MHz CH-High 30MHz~3GHz

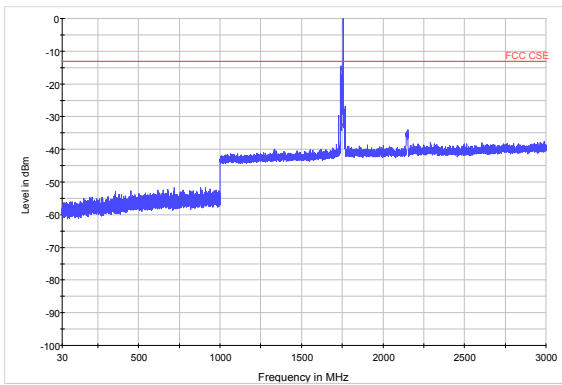

LTE Band 4 15MHz CH-High 3GHz~18GHz

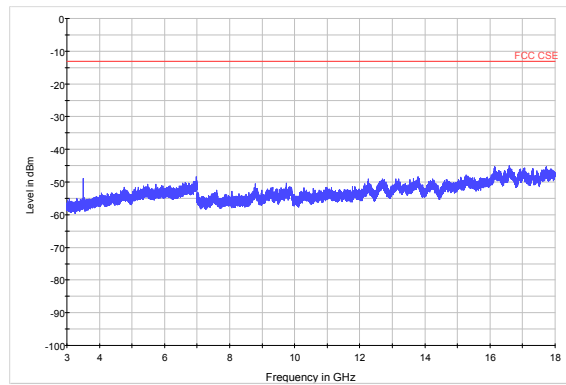



LTE Band 4 20MHz CH-Low 30MHz~3GHz

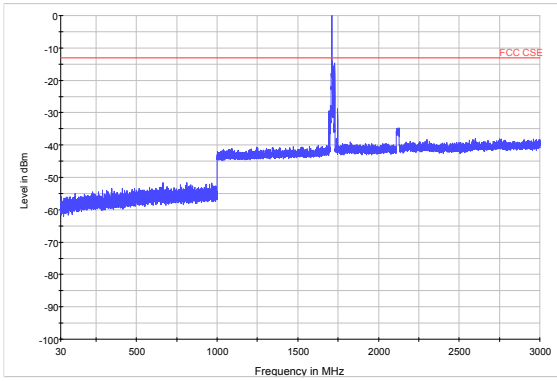

LTE Band 4 20MHz CH-Low 3GHz~18GHz

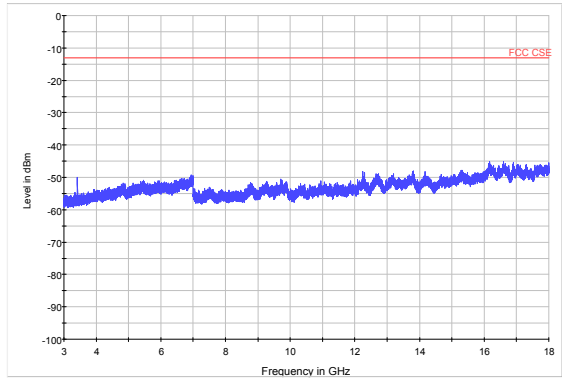

LTE Band 4 20MHz CH-Middle 30MHz~3GHz

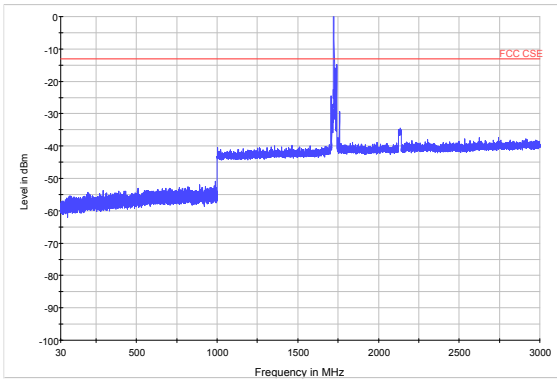

LTE Band 4 20MHz CH-Middle 3GHz~18GHz

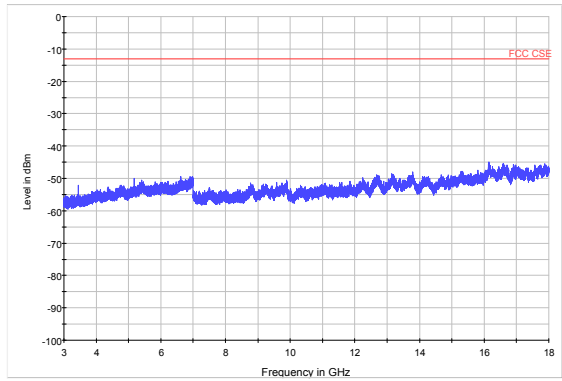

LTE Band 4 20MHz CH-High 30MHz~3GHz

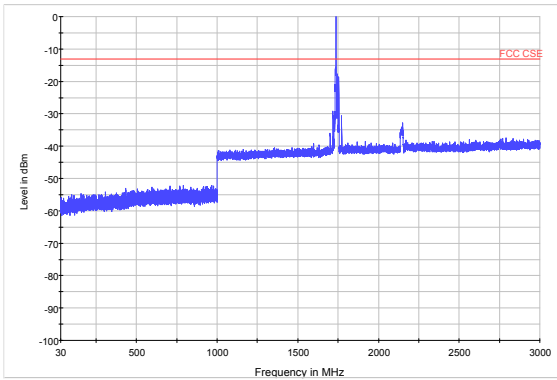

LTE Band 4 20MHz CH-High 3GHz~18GHz

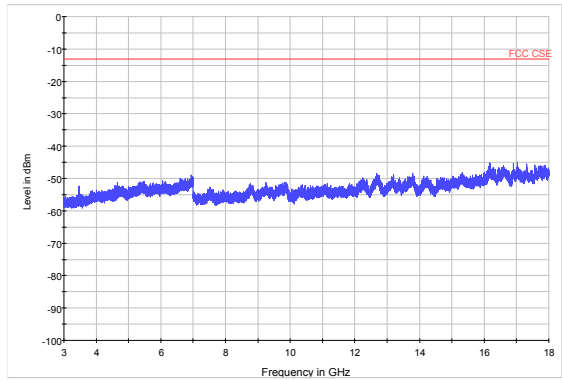



LTE Band 7 5MHz CH-Low 30MHz~3GHz

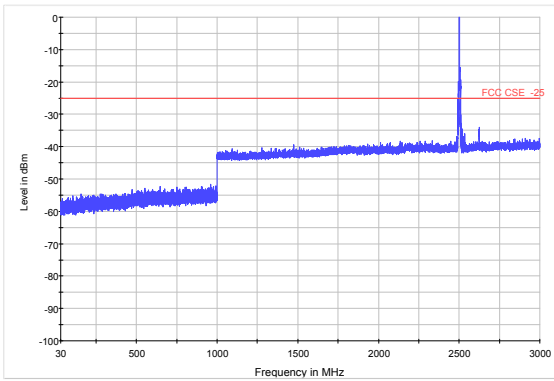

LTE Band 7 5MHz CH-Middle 30MHz~3GHz

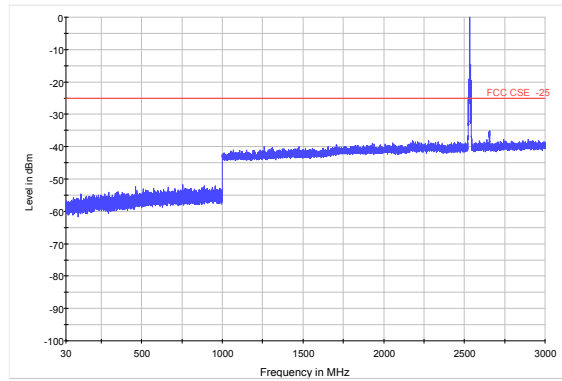

LTE Band 7 5MHz CH-Low 3GHz~18GHz

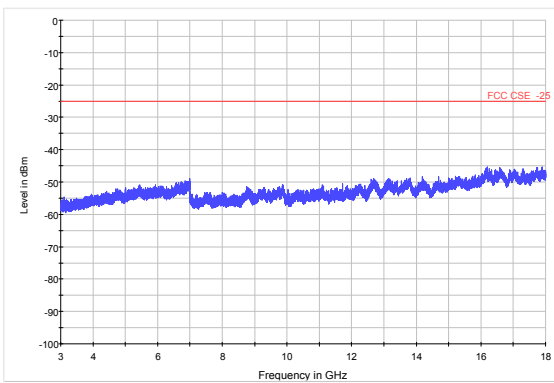

LTE Band 7 5MHz CH-Middle 3GHz~18GHz

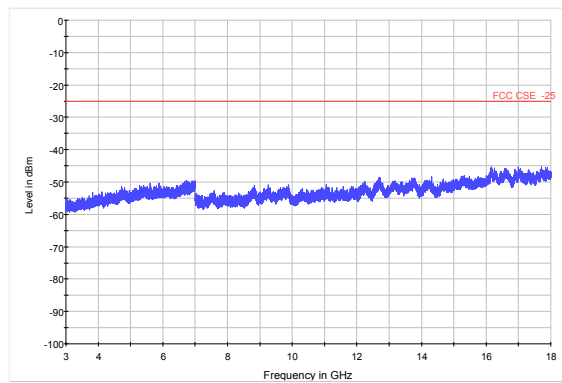

LTE Band 7 5MHz CH-Low 18GHz~26.5GHz

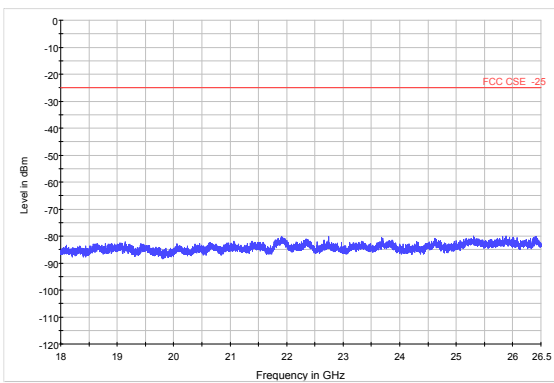

LTE Band 7 5MHz CH-Middle 18GHz~26.5GHz

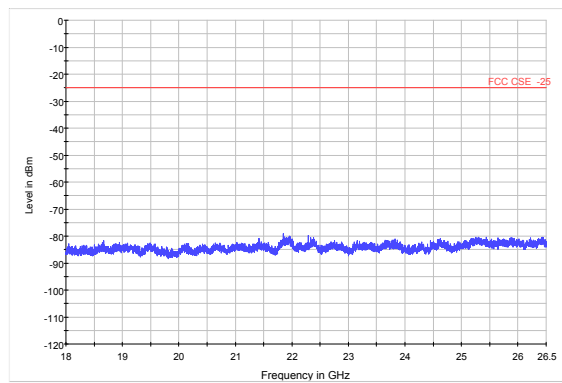



LTE Band 7 5MHz CH-High 30MHz~3GHz

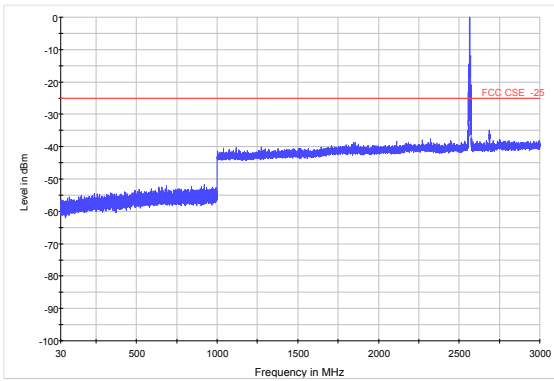

LTE Band 7 10MHz CH-Low 30MHz~3GHz

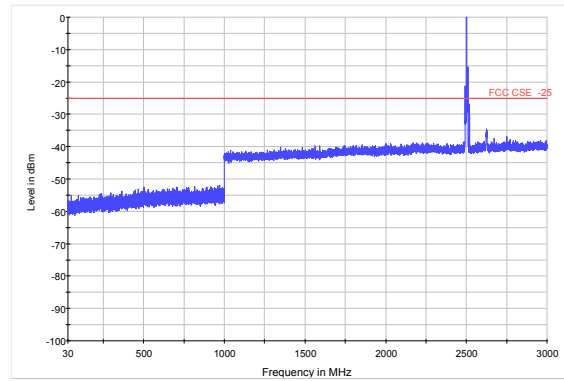

LTE Band 7 5MHz CH-High 3GHz~18GHz

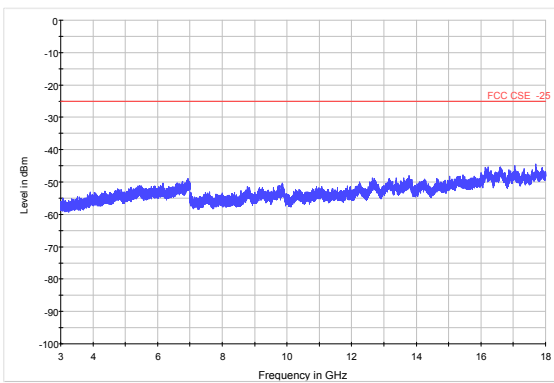

LTE Band 7 10MHz CH-Low 3GHz~18GHz

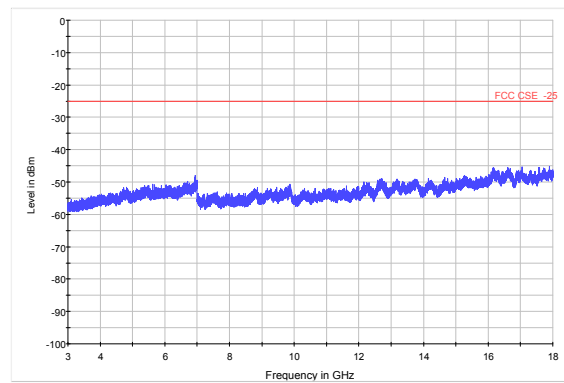

LTE Band 7 5MHz CH-High 18GHz~26.5GHz

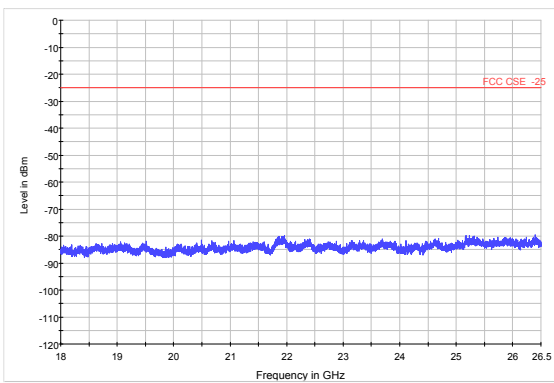

LTE Band 7 10MHz C CH-Low 18GHz~26.5GHz

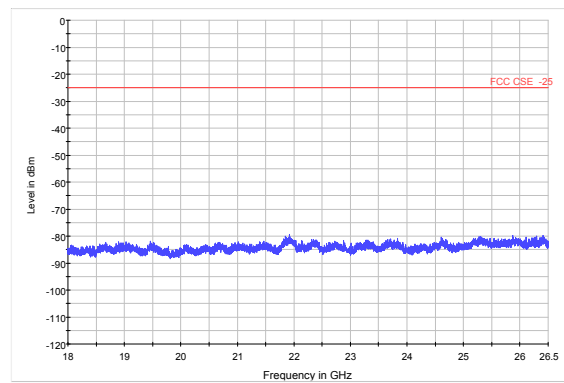



LTE Band 7 10MHz CH-Middle 30MHz~3GHz

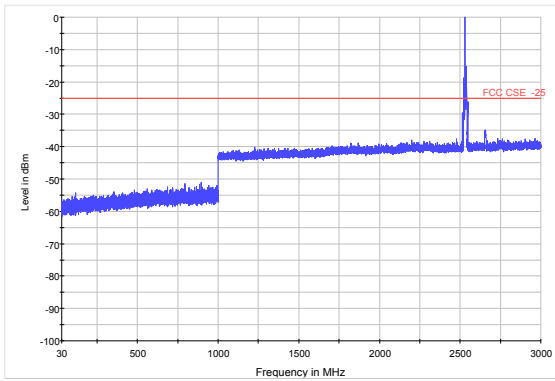

LTE Band 7 10MHz CH-High 30MHz~3GHz

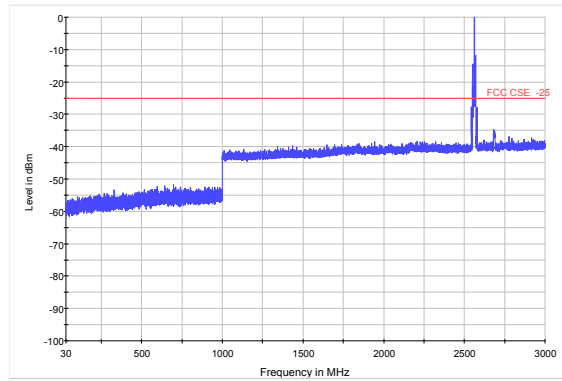

LTE Band 7 10MHz CH-Middle 3GHz~18GHz

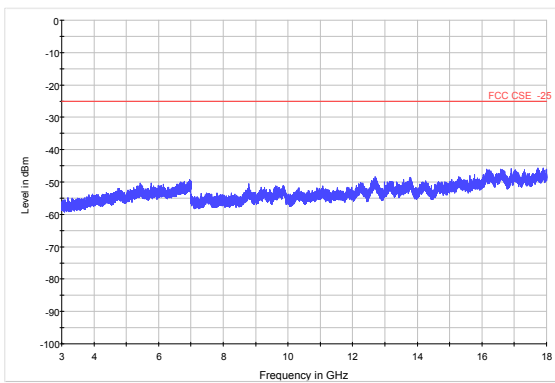

LTE Band 7 10MHz CH-High 3GHz~18GHz

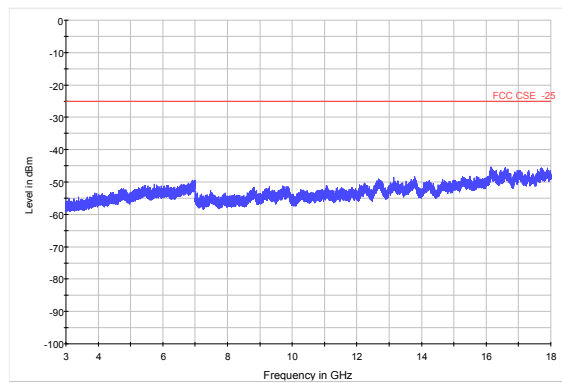

LTE Band 7 10MHz CH-Middle 18GHz~26.5GHz

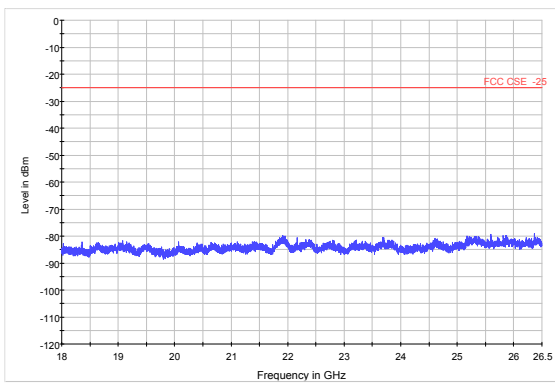

LTE Band 7 10MHz CH-High 18GHz~26.5GHz

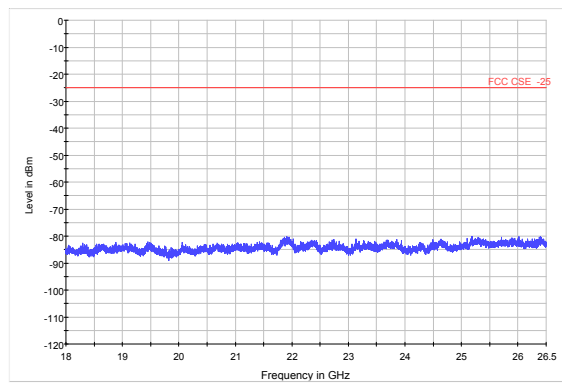



LTE Band 7 15MHz CH-Low 30MHz~3GHz

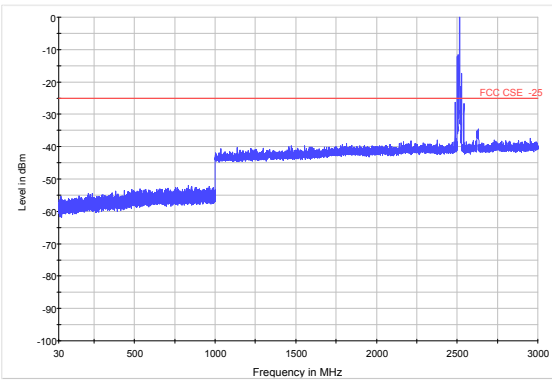

LTE Band 7 15MHz CH-Middle 30MHz~3GHz

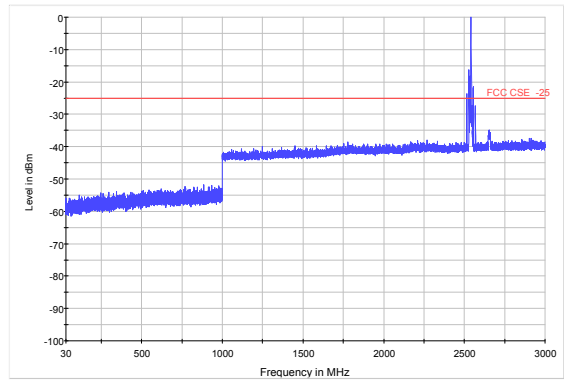

LTE Band 7 15MHz CH-Low 3GHz~18GHz

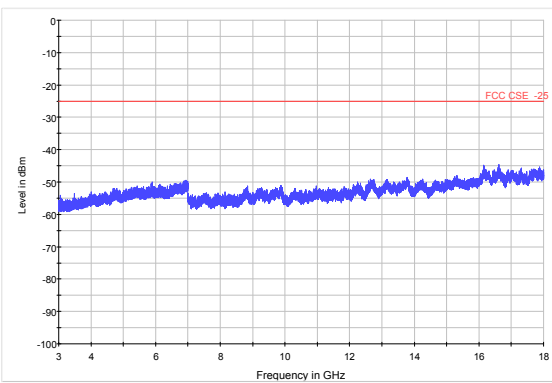

LTE Band 7 15MHz CH-Middle 3GHz~18GHz

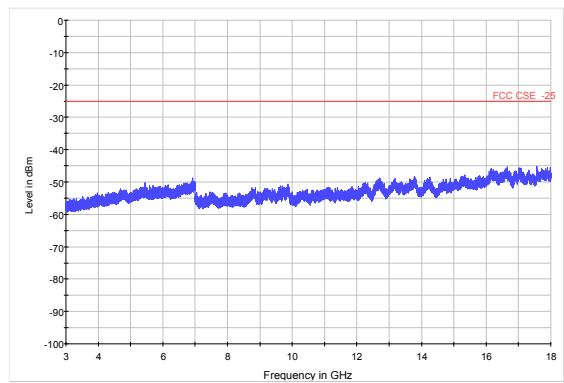

LTE Band 7 15MHz CH-Low 18GHz~26.5GHz

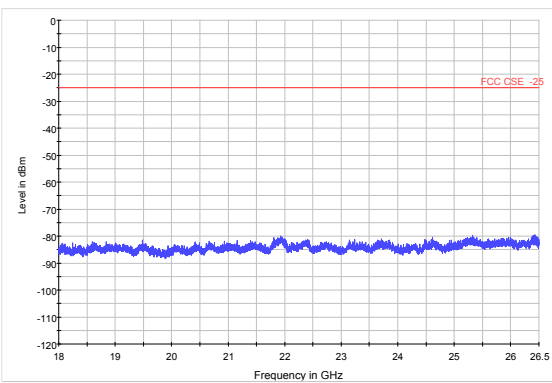

LTE Band 7 15MHz CH-Middle 18GHz~26.5GHz

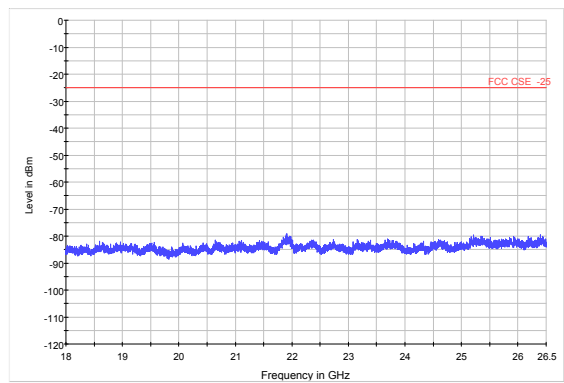



LTE Band 7 15MHz CH-High 30MHz~3GHz

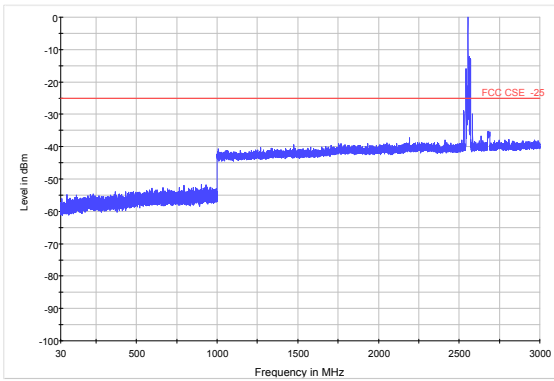

LTE Band 7 20MHz CH-Low 30MHz~3GHz

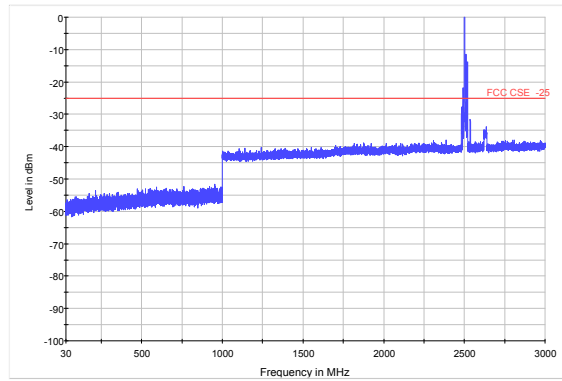

LTE Band 7 15MHz CH-High 3GHz~18GHz

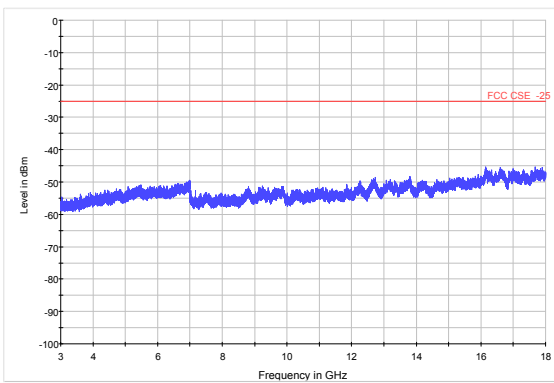

LTE Band 7 20MHz CH-Low 3GHz~18GHz

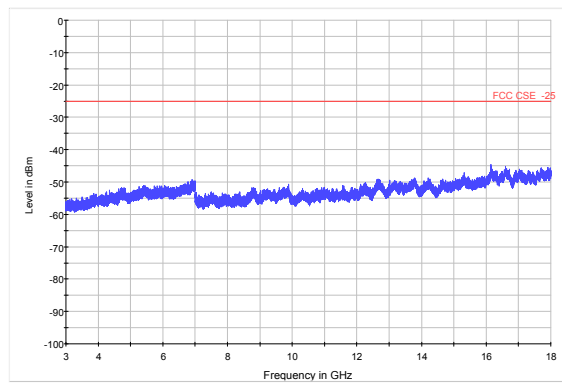

LTE Band 7 15MHz CH-High 18GHz~26.5GHz

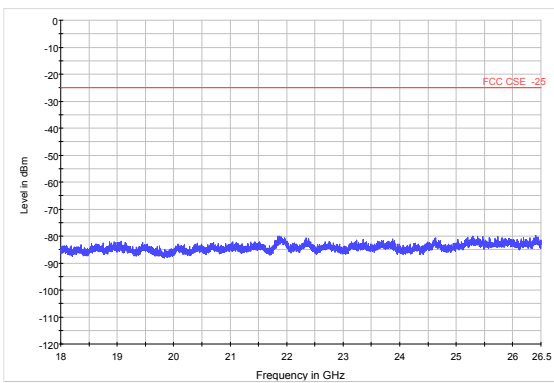

LTE Band 7 20MHz CH-Low 18GHz~26.5GHz

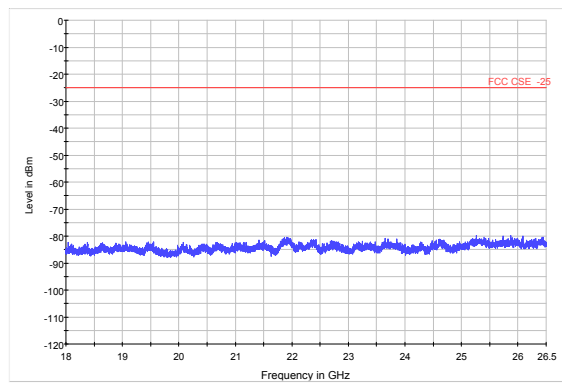



LTE Band 7 20MHz CH-Middle 30MHz~3GHz

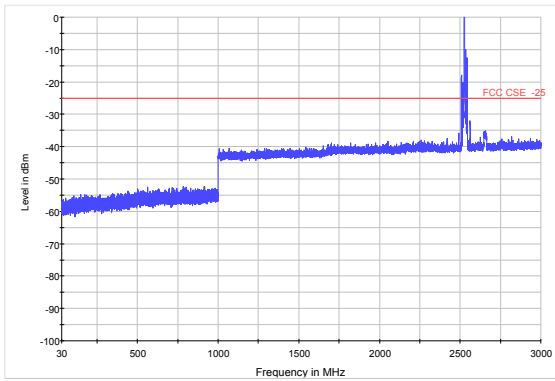

LTE Band 7 20MHz CH-High 30MHz~3GHz

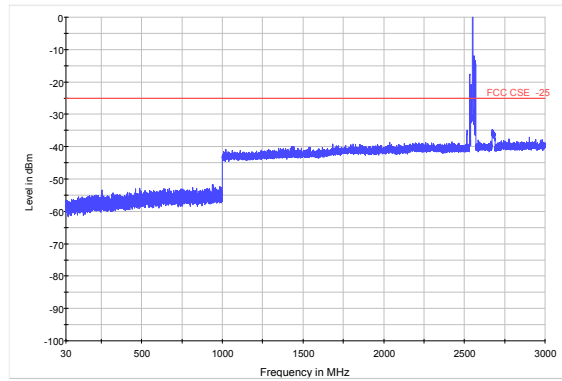

LTE Band 7 20MHz CH-Middle 3GHz~18GHz

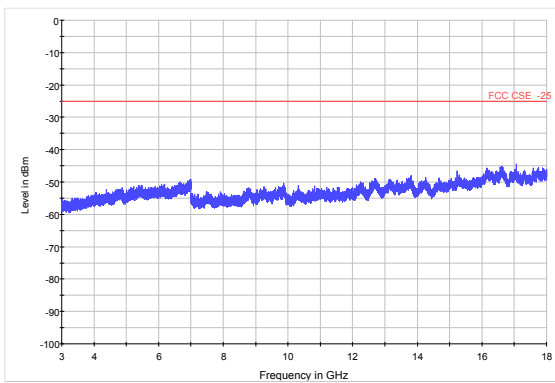

LTE Band 7 20MHz CH-High 3GHz~18GHz

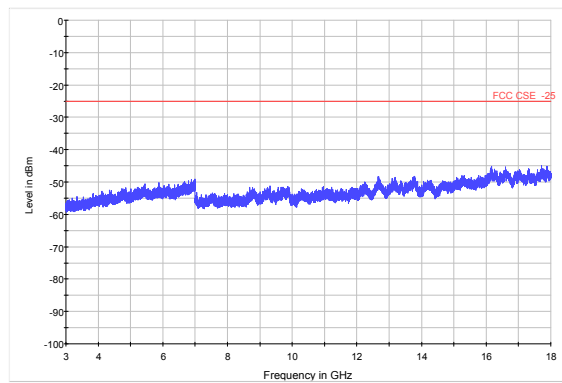

LTE Band 7 20MHz CH-Middle 18GHz~26.5GHz

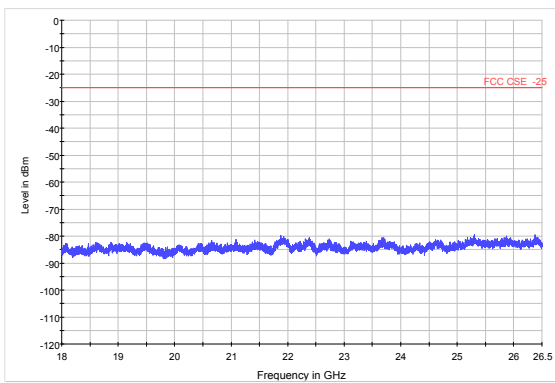

LTE Band 7 20MHz CH-High 18GHz~26.5GHz

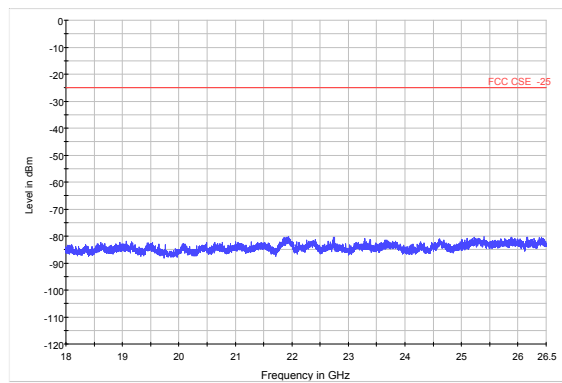



LTE Band 38 5MHz CH-Low 30MHz~3GHz

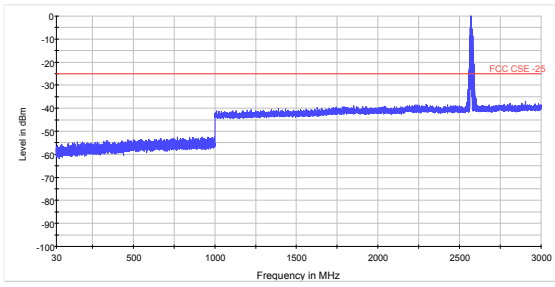

LTE Band 38 5MHz CH-Middle 30MHz~3GHz

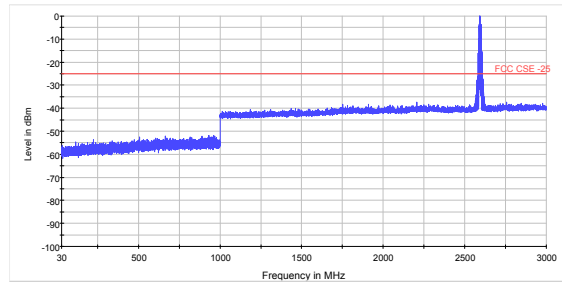

LTE Band 38 5MHz CH-Low 3GHz~18GHz

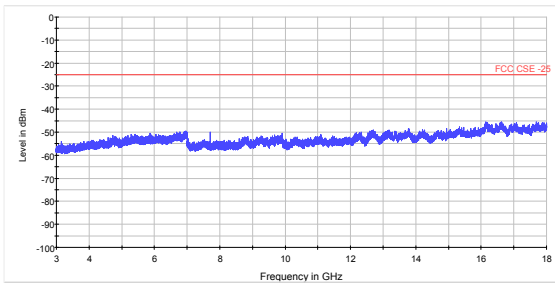

LTE Band 38 5MHz CH-Middle 3GHz~18GHz

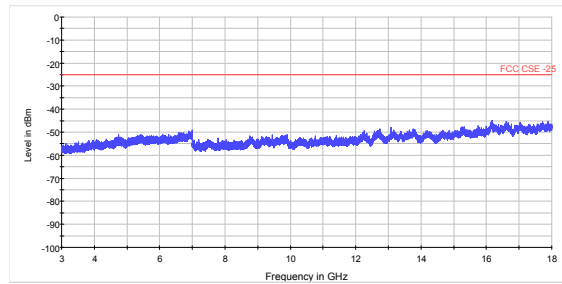

LTE Band 38 5MHz CH-Low 18GHz~26.5GHz

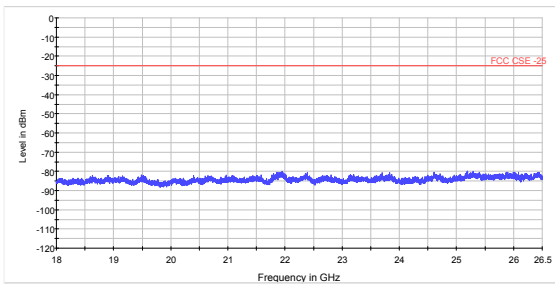

LTE Band 38 5MHz CH-Middle 18GHz~26.5GHz

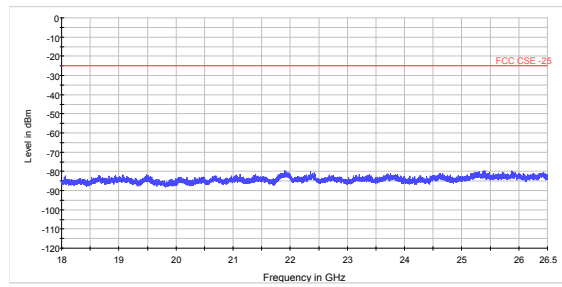



LTE Band 38 5MHz CH-High 30MHz~3GHz

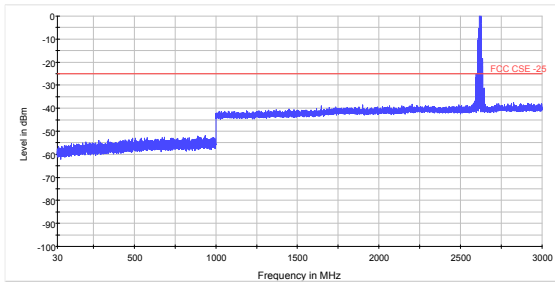

LTE Band 38 10MHz CH-Low 30MHz~3GHz

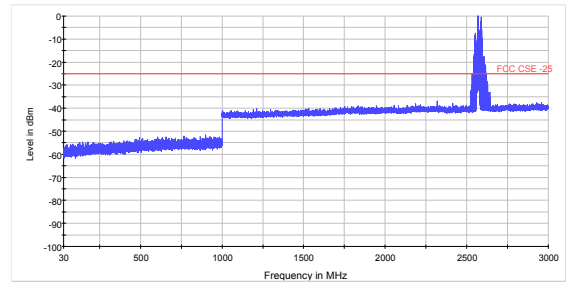

LTE Band 38 5MHz CH-High 3GHz~18GHz

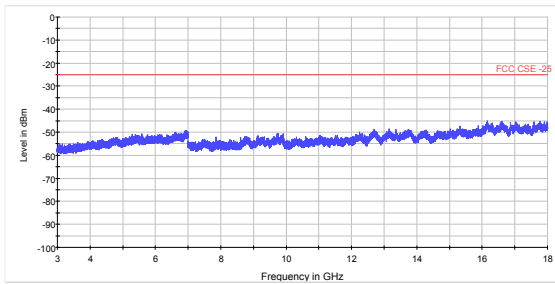

LTE Band 38 10MHz CH-Low 3GHz~18GHz

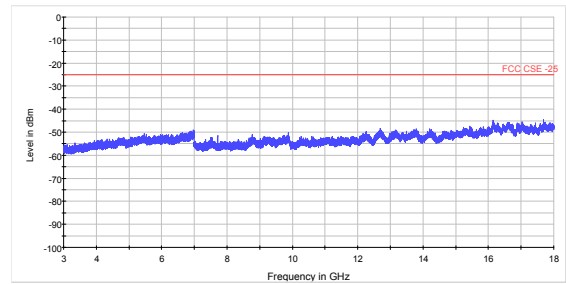

LTE Band 38 5MHz CH-High 18GHz~26.5GHz

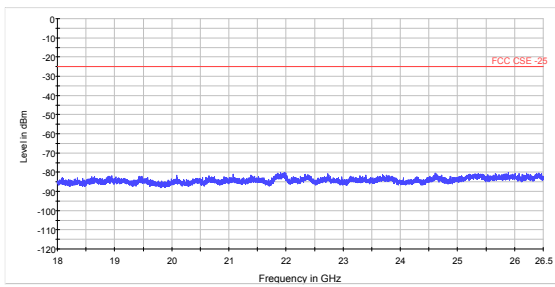

LTE Band 38 10MHz C CH-Low
18GHz~26.5GHz

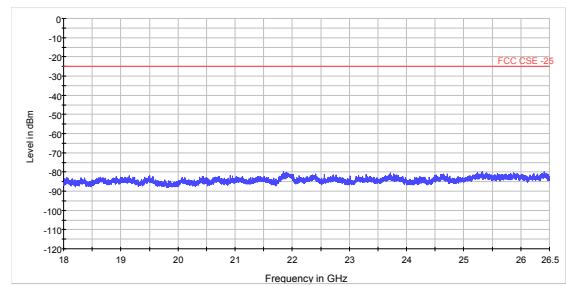



LTE Band 38 10MHz CH-Middle 30MHz~3GHz

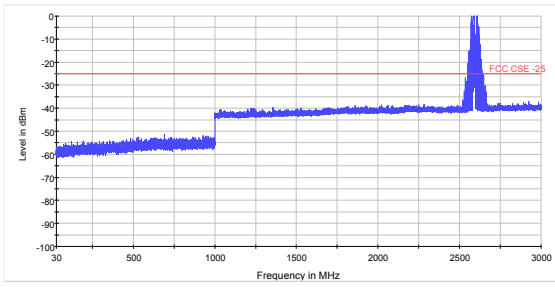

LTE Band 38 10MHz CH-High 30MHz~3GHz

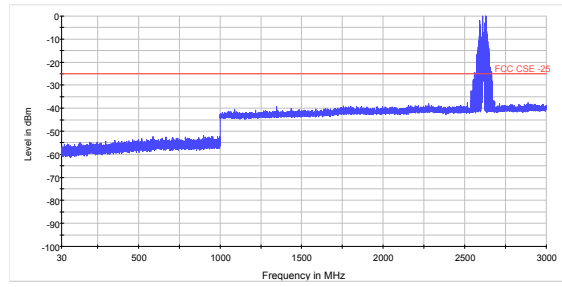

LTE Band 38 10MHz CH-Middle 3GHz~18GHz

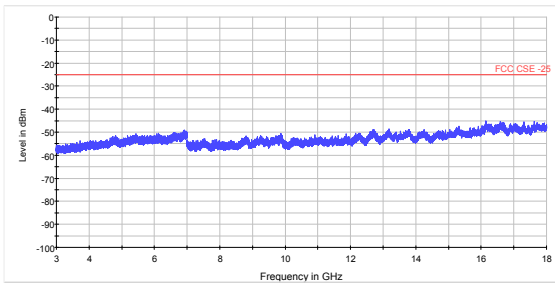

LTE Band 38 10MHz CH-High 3GHz~18GHz

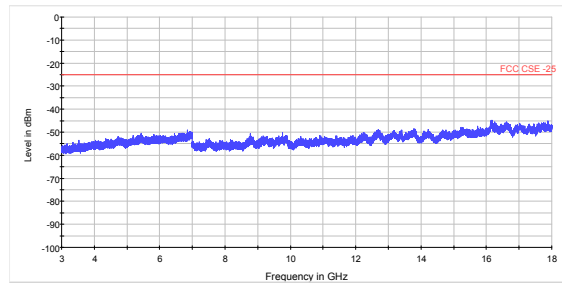

LTE Band 38 10MHz CH-Middle 18GHz~26.5GHz

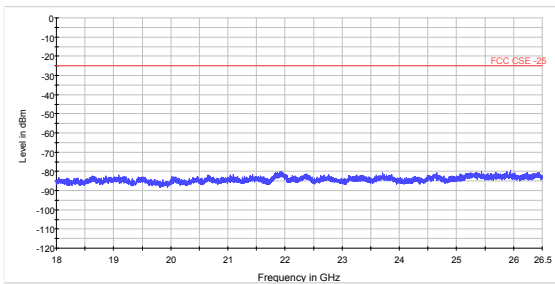

LTE Band 710MHz CH-High 18GHz~26.5GHz

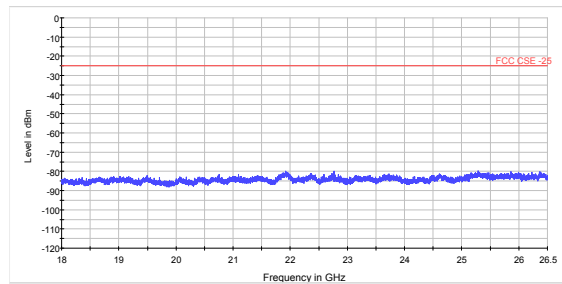



LTE Band 38 15MHz CH-Low 30MHz~3GHz

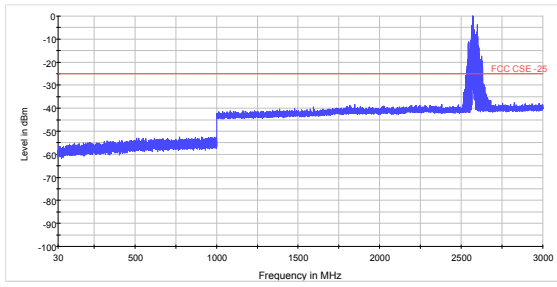

LTE Band 38 15MHz CH-Middle 30MHz~3GHz

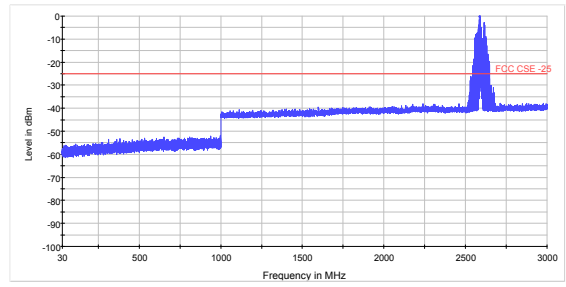

LTE Band 38 15MHz CH-Low 3GHz~18GHz

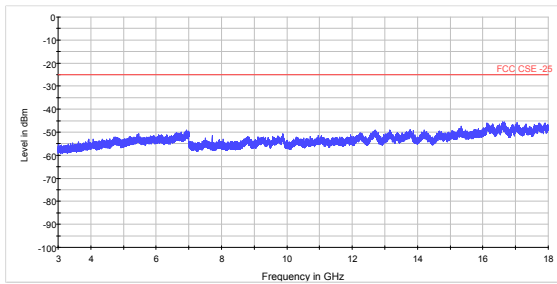

LTE Band 38 15MHz CH-Middle 3GHz~18GHz

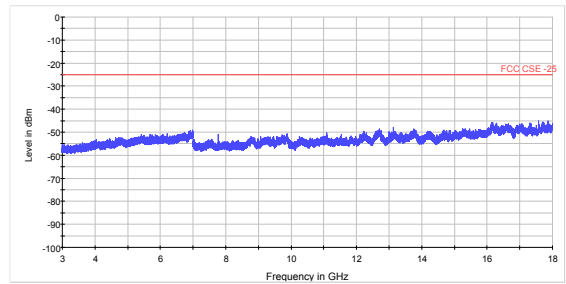

LTE Band 38 15MHz CH-Low 18GHz~26.5GHz

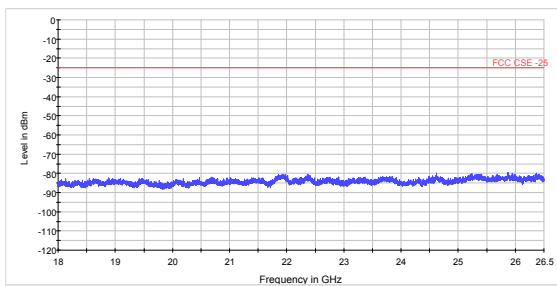

LTE Band 38 15MHz CH-Middle 18GHz~26.5GHz

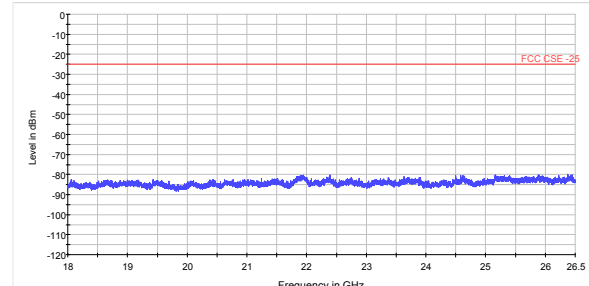



LTE Band 38 15MHz CH-High 30MHz~3GHz

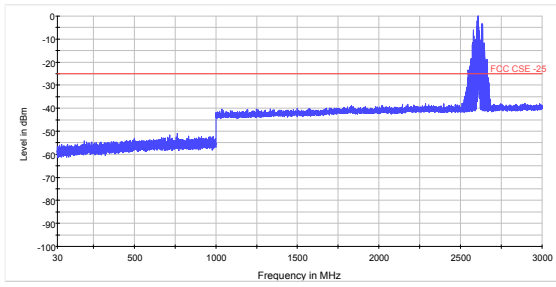

LTE Band 38 20MHz CH-Low 30MHz~3GHz

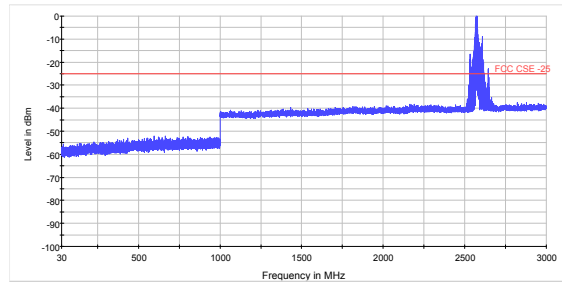

LTE Band 38 15MHz CH-High 3GHz~18GHz

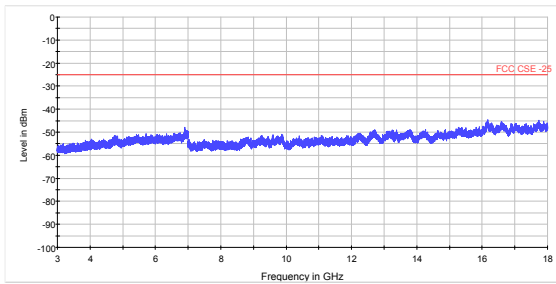

LTE Band 38 20MHz CH-Low 3GHz~18GHz

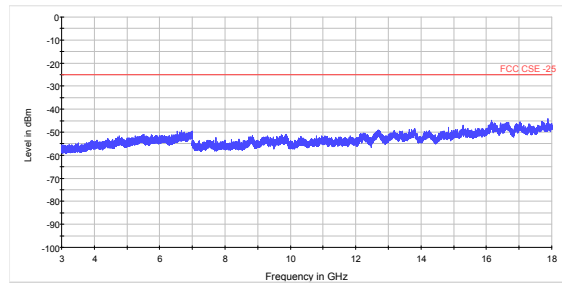

LTE Band 38 15MHz CH-High 18GHz~26.5GHz

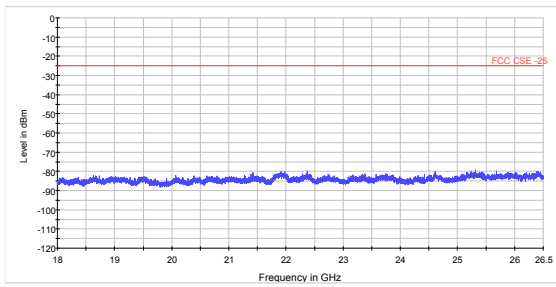

LTE Band 38 20MHz CH-Low 18GHz~26.5GHz

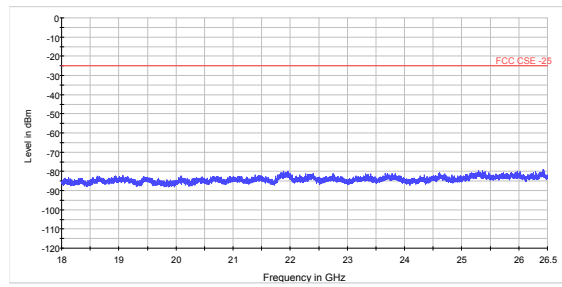



LTE Band 38 20MHz CH-Middle 30MHz~3GHz

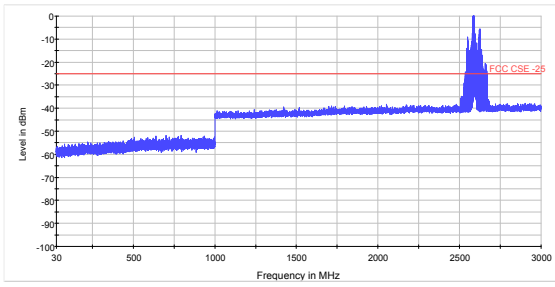

LTE Band 38 20MHz CH-High 30MHz~3GHz

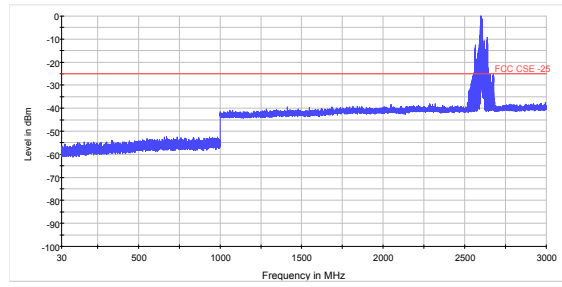

LTE Band 38 20MHz CH-Middle 3GHz~18GHz

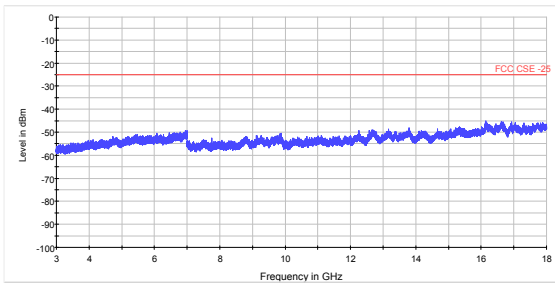

LTE Band 38 20MHz CH-High 3GHz~18GHz

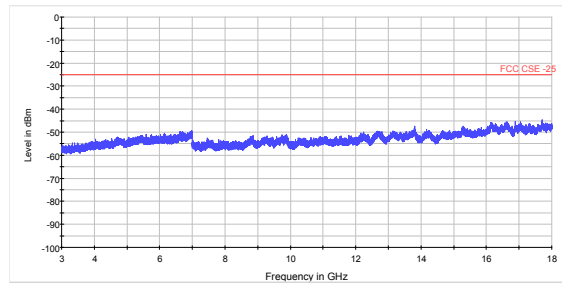

LTE Band 38 20MHz CH-Middle 18GHz~26.5GHz

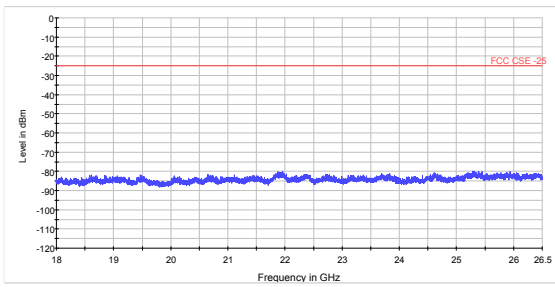

LTE Band 38 20MHz CH-High 18GHz~26.5GHz

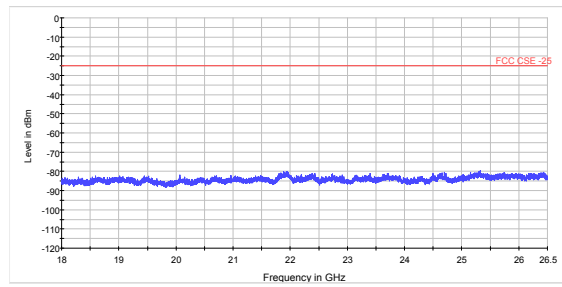

5.8 Radiates Spurious Emission

Ambient condition

Temperature	Relative humidity	Pressure
23°C ~25°C	45%~50%	101.5kPa

Method of Measurement

- The testing follows FCC KDB 971168 v02r02 Section 5.8 and ANSI/TIA-603-D-2010.
- Above 30MHz: The EUT is placed on a turntable 0.8 meters above the ground in the chamber, 3 meter away from the antenna. The maximal emission value is acquired by adjusting the antenna height, polarisation and turntable azimuth. Normally, the height range of antenna is 1 m to 4 m, the azimuth range of turntable is 0° to 360°, and the receive antenna has two polarizations Vertical (V) and Horizontal (H). Above 1GHz: (Note: the FCC's permission to use 1.5m as an alternative per TCBC Conf call of Dec. 2, 2014.) The EUT is placed on a turntable 1.5 meters above the ground in the chamber, 3 meter away from the antenna. The maximal emission value is acquired by adjusting the antenna height, polarisation and turntable azimuth. Normally, the height range of antenna is 1 m to 4 m, the azimuth range of turntable is 0° to 360°, and the receive antenna has two polarizations Vertical (V) and Horizontal (H).
- A log-periodic antenna or double-ridged waveguide horn antenna shall be substituted in place of the EUT. The log-periodic antenna will be driven by a signal generator and the level will be adjusted till the same power value on the spectrum analyzer or receiver. The level of the spurious emissions can be calculated through the level of the signal generator, cable loss, the gain of the substitution antenna and the reading of the spectrum analyzer or receiver.
- The EUT is then put into continuously transmitting mode at its maximum power level during the test. Set Test Receiver or Spectrum RBW=1MHz, VBW=3MHz, And the maximum value of the receiver should be recorded as (Pr).
- The EUT shall be replaced by a substitution antenna. In the chamber, an substitution antenna for the frequency band of interest is placed at the reference point of the chamber. An RF Signal source for the frequency band of interest is connected to the substitution antenna with a cable that has been constructed to not interfere with the radiation pattern of the antenna. A power (PMea) is applied to the input of the substitution antenna, and adjust the level of the signal generator output until the value of the receiver reach the previously recorded (Pr). The power of signal source (PMea) is recorded. The test should be performed by rotating the test item and adjusting the receiving antenna polarization.
- A amplifier should be connected to the Signal Source output port. And the cable should be connect between the Amplifier and the Substitution Antenna. The cable loss (Pcl) ,the Substitution Antenna Gain (Ga) and the Amplifier Gain (PAg) should be recorded after test.
- The measurement results are obtained as described below:

$$\text{Power(EIRP)} = \text{PMea} - \text{PAg} - \text{Pcl} + \text{Ga}$$
The measurement results are amend as described below:

$$\text{Power(EIRP)} = \text{PMea} - \text{Pcl} + \text{Ga}$$
- This value is EIRP since the measurement is calibrated using an antenna of known gain (2.15 dBi) and known input power. ERP can be calculated from EIRP by subtracting the gain of the dipole, $\text{ERP} = \text{EIRP} - 2.15\text{dBi}$.

Test setup

30MHz~~~ 1GHz

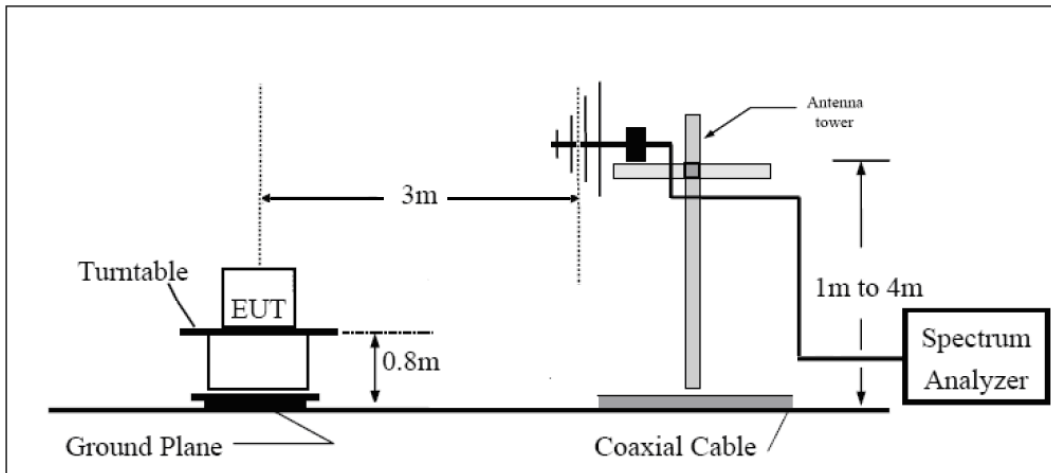

Above 1GHz

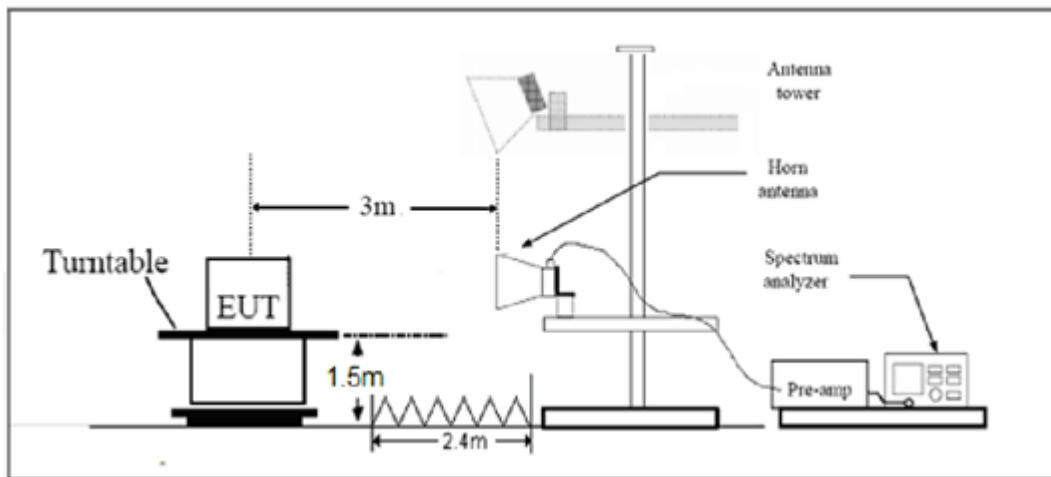

Note: Area side:2.4mX3.6m

The radiated emission was measured in the following position: EUT stand-up position (Z axis), lie-down position (X, Y axis). The worst emission was found in stand-up position (Z axis) and the worst case was recorded.

Limits

Rule Part 27.53(h) specifies that “for operations in the 1695-1710 MHz, 1710-1755 MHz, 1755-1780 MHz, 1915-1920 MHz, 1995-2000 MHz, 2000-2020 MHz, 2110-2155 MHz, 2155-2180 MHz, and 2180-2200 bands, the power of any emission outside a licensee's frequency block shall be attenuated below the transmitter power (P) in watts by at least $43 + 10 \log_{10} (P)$ dB..”

Rule Part 27.53(m) $55 + 10 \log (P)$ dB on all frequencies more than X megahertz from the channel edge, where X is the greater of 6 megahertz or the actual emission bandwidth as defined in paragraph (m)(4) of this section.

Part 27.53(h) Limit	-13 dBm
---------------------	---------



Part 27.53(m) Limit	-25 dBm
---------------------	---------

Measurement Uncertainty

The assessed measurement uncertainty to ensure 95% confidence level for the normal distribution is with the coverage factor $k = \pm 1.96$, $U = \pm 3.55$ dB.

Test Result

LTE Band 4 QPSK 1.4MHz CH-Low, RB 1

Harmonic	Frequency (MHz)	SG (dBm)	Cable Loss (dB)	Gain (dBi)	Antenna Polarization	EIRP Level (dBm)	Limit (dBm)	Margin (dB)	Azimuth (deg)
2	3421.4	-56.75	2.6	10.15	Vertical	-49.2	-13.0	36.22	90
3	5132.1	-49.35	2.4	11.35	Vertical	-40.4	-13.0	27.45	45
4	6842.8	-54.95	4.5	10.85	Vertical	-48.6	-13.0	35.55	135
5	8553.5	-52.25	5.1	11.35	Vertical	-46.0	-13.0	33.05	270
6	10264.2	-49.55	5.3	11.95	Vertical	-42.9	-13.0	29.89	180
7	11974.9	-51.55	5.5	13.55	Vertical	-43.5	-13.0	30.49	315
8	13685.6	-46.55	6.3	13.75	Vertical	-39.1	-13.0	26.13	45
9	15396.3	-50.05	6.7	13.85	Vertical	-42.9	-13.0	29.86	135
10	17107.0	-45.65	6.8	14.25	Vertical	-38.2	-13.0	25.21	90

- Note: 1.The other Spurious RF Radiated emissions level is no more than noise floor.
 2. The worst emission was found in the antenna is vertical position.

LTE Band 4 QPSK 1.4MHz CH-Middle, RB 1

Harmonic	Frequency (MHz)	SG (dBm)	Cable Loss (dB)	Gain (dBi)	Antenna Polarization	EIRP Level (dBm)	Limit (dBm)	Margin (dB)	Azimuth (deg)
2	3465.0	-61.25	2.6	10.75	Vertical	-53.1	-13.0	40.06	225
3	5197.5	-49.45	2.4	11.05	Vertical	-40.8	-13.0	27.81	135
4	6930.0	-55.25	4.5	11.15	Vertical	-48.6	-13.0	35.60	180
5	8662.5	-51.75	5.1	11.35	Vertical	-45.5	-13.0	32.51	270
6	10395.0	-48.55	5.3	11.95	Vertical	-41.9	-13.0	28.91	45
7	12127.5	-50.85	5.5	13.55	Vertical	-42.8	-13.0	29.80	90
8	13860.0	-46.85	6.3	13.75	Vertical	-39.4	-13.0	26.45	180
9	15592.5	-49.85	6.7	13.85	Vertical	-42.7	-13.0	29.73	135
10	17325.0	-45.65	6.8	14.25	Vertical	-38.2	-13.0	25.17	225

- Note: 1.The other Spurious RF Radiated emissions level is no more than noise floor.
 2. The worst emission was found in the antenna is vertical position.

LTE Band 4 QPSK 1.4MHz CH-High, RB 1

Harmonic	Frequency (MHz)	SG (dBm)	Cable Loss (dB)	Gain (dBi)	Antenna Polarization	EIRP Level (dBm)	Limit (dBm)	Margin (dB)	Azimuth (deg)
2	3508.6	-56.85	2.6	10.15	Vertical	-49.3	-13.0	36.32	45
3	5262.9	-51.55	2.4	11.05	Vertical	-42.9	-13.0	29.85	90
4	7017.2	-54.75	4.5	11.15	Vertical	-48.1	-13.0	35.12	135
5	8771.5	-53.05	5.1	11.35	Vertical	-46.8	-13.0	33.78	270
6	10525.8	-49.75	5.3	11.95	Vertical	-43.1	-13.0	30.09	180
7	12280.1	-50.55	5.5	13.55	Vertical	-42.5	-13.0	29.53	315
8	14034.4	-45.85	6.3	13.75	Vertical	-38.4	-13.0	25.40	45
9	15788.7	-47.65	6.7	13.85	Vertical	-40.5	-13.0	27.48	135
10	17543.0	-46.15	6.8	14.25	Vertical	-38.7	-13.0	25.71	90

Note: 1.The other Spurious RF Radiated emissions level is no more than noise floor.

2. The worst emission was found in the antenna is vertical position.

LTE Band 4 QPSK 3MHz CH-Low, RB 1

Harmonic	Frequency (MHz)	SG (dBm)	Cable Loss (dB)	Gain (dBi)	Antenna Polarization	EIRP Level (dBm)	Limit (dBm)	Margin (dB)	Azimuth (deg)
2	3423.0	-54.65	2.6	10.15	Vertical	-47.1	-13.0	34.09	225
3	5134.5	-48.15	2.4	11.35	Vertical	-39.2	-13.0	26.20	135
4	6846.0	-55.95	4.5	10.85	Vertical	-49.6	-13.0	36.55	180
5	8557.5	-52.65	5.1	11.35	Vertical	-46.4	-13.0	33.38	270
6	10269.0	-49.35	5.3	11.95	Vertical	-42.7	-13.0	29.65	45
7	11980.5	-51.55	5.5	13.55	Vertical	-43.5	-13.0	30.49	90
8	13692.0	-47.05	6.3	13.75	Vertical	-39.6	-13.0	26.63	180
9	15403.5	-50.05	6.7	13.85	Vertical	-42.9	-13.0	29.86	135
10	17115.0	-46.35	6.8	14.25	Vertical	-38.9	-13.0	25.85	225

Note: 1.The other Spurious RF Radiated emissions level is no more than noise floor.

2. The worst emission was found in the antenna is vertical position.

LTE Band 4 QPSK 3MHz CH-Middle, RB 1

Harmonic	Frequency (MHz)	SG (dBm)	Cable Loss (dB)	Gain (dBi)	Antenna Polarization	EIRP Level (dBm)	Limit (dBm)	Margin (dB)	Azimuth (deg)
2	3465.0	-62.15	2.6	10.75	Vertical	-54.0	-13.0	41.03	45
3	5197.5	-46.85	2.4	11.05	Vertical	-38.2	-13.0	25.24	135
4	6930.0	-55.35	4.5	11.15	Vertical	-48.7	-13.0	35.67	270
5	8662.5	-51.45	5.1	11.35	Vertical	-45.2	-13.0	32.21	180
6	10395.0	-49.55	5.3	11.95	Vertical	-42.9	-13.0	29.91	315
7	12127.5	-50.85	5.5	13.55	Vertical	-42.8	-13.0	29.80	45
8	13860.0	-46.55	6.3	13.75	Vertical	-39.1	-13.0	26.15	135
9	15592.5	-49.85	6.7	13.85	Vertical	-42.7	-13.0	29.73	90
10	17325.0	-46.05	6.8	14.25	Vertical	-38.6	-13.0	25.63	225

Note: 1.The other Spurious RF Radiated emissions level is no more than noise floor.

2. The worst emission was found in the antenna is vertical position.

LTE Band 4 QPSK 3MHz CH-High, RB 1

Harmonic	Frequency (MHz)	SG (dBm)	Cable Loss (dB)	Gain (dBi)	Antenna Polarization	EIRP Level (dBm)	Limit (dBm)	Margin (dB)	Azimuth (deg)
2	3507.0	-55.25	2.6	10.15	Vertical	-47.7	-13.0	34.73	135
3	5260.5	-49.15	2.4	11.05	Vertical	-40.5	-13.0	27.51	180
4	7014.0	-55.25	4.5	11.15	Vertical	-48.6	-13.0	35.63	270
5	8767.5	-53.05	5.1	11.35	Vertical	-46.8	-13.0	33.78	45
6	10521.0	-50.05	5.3	11.95	Vertical	-43.4	-13.0	30.36	90
7	12274.5	-50.55	5.5	13.55	Vertical	-42.5	-13.0	29.53	180
8	14028.0	-46.85	6.3	13.75	Vertical	-39.4	-13.0	26.40	135
9	15781.5	-47.65	6.7	13.85	Vertical	-40.5	-13.0	27.48	225
10	17535.0	-45.75	6.8	14.25	Vertical	-38.3	-13.0	25.31	45

Note: 1.The other Spurious RF Radiated emissions level is no more than noise floor.

2. The worst emission was found in the antenna is vertical position.

LTE Band 4 QPSK 5MHz CH-Low, RB 1

Harmonic	Frequency (MHz)	SG (dBm)	Cable Loss (dB)	Gain (dBi)	Antenna Polarization	EIRP Level (dBm)	Limit (dBm)	Margin (dB)	Azimuth (deg)
2	3425.0	-55.95	2.6	10.15	Vertical	-48.4	-13.0	35.38	135
3	5137.5	-48.65	2.4	11.35	Vertical	-39.7	-13.0	26.68	270
4	6850.0	-55.65	4.5	10.85	Vertical	-49.3	-13.0	36.32	180
5	8562.5	-53.65	5.1	11.35	Vertical	-47.4	-13.0	34.38	315
6	10275.0	-49.15	5.3	11.95	Vertical	-42.5	-13.0	29.45	45
7	11987.5	-51.55	5.5	13.55	Vertical	-43.5	-13.0	30.49	135
8	13700.0	-47.05	6.3	13.75	Vertical	-39.6	-13.0	26.63	90
9	15412.5	-49.45	6.7	13.85	Vertical	-42.3	-13.0	29.35	225
10	17125.0	-47.35	6.8	14.25	Vertical	-39.9	-13.0	26.85	135

Note: 1.The other Spurious RF Radiated emissions level is no more than noise floor.

2. The worst emission was found in the antenna is vertical position.

LTE Band 4 QPSK 5MHz CH-Middle, RB 1

Harmonic	Frequency (MHz)	SG (dBm)	Cable Loss (dB)	Gain (dBi)	Antenna Polarization	EIRP Level (dBm)	Limit (dBm)	Margin (dB)	Azimuth (deg)
2	3465.0	-60.45	2.6	10.75	Vertical	-52.3	-13.0	39.30	180
3	5197.5	-49.25	2.4	11.05	Vertical	-40.6	-13.0	27.59	270
4	6930.0	-55.35	4.5	11.15	Vertical	-48.7	-13.0	35.67	45
5	8662.5	-51.85	5.1	11.35	Vertical	-45.6	-13.0	32.61	90
6	10395.0	-49.55	5.3	11.95	Vertical	-42.9	-13.0	29.91	180
7	12127.5	-50.35	5.5	13.55	Vertical	-42.3	-13.0	29.30	135
8	13860.0	-47.05	6.3	13.75	Vertical	-39.6	-13.0	26.64	225
9	15592.5	-49.25	6.7	13.85	Vertical	-42.1	-13.0	29.13	45
10	17325.0	-47.05	6.8	14.25	Vertical	-39.6	-13.0	26.63	135

Note: 1.The other Spurious RF Radiated emissions level is no more than noise floor.

2. The worst emission was found in the antenna is vertical position.

LTE Band 4 QPSK 5MHz CH-High, RB 1

Harmonic	Frequency (MHz)	SG (dBm)	Cable Loss (dB)	Gain (dBi)	Antenna Polarization	EIRP Level (dBm)	Limit (dBm)	Margin (dB)	Azimuth (deg)
2	3505.0	-54.55	2.6	10.15	Vertical	-47.0	-13.0	34.01	270
3	5257.5	-50.75	2.4	11.05	Vertical	-42.1	-13.0	29.06	180
4	7010.0	-55.55	4.5	11.15	Vertical	-48.9	-13.0	35.85	315
5	8762.5	-53.45	5.1	11.35	Vertical	-47.2	-13.0	34.18	45
6	10515.0	-50.05	5.3	11.95	Vertical	-43.4	-13.0	30.36	135
7	12267.5	-50.35	5.5	13.55	Vertical	-42.3	-13.0	29.33	90
8	14020.0	-47.85	6.3	13.75	Vertical	-40.4	-13.0	27.40	225
9	15772.5	-47.65	6.7	13.85	Vertical	-40.5	-13.0	27.48	135
10	17525.0	-46.25	6.8	14.25	Vertical	-38.8	-13.0	25.81	180

- Note: 1.The other Spurious RF Radiated emissions level is no more than noise floor.
2. The worst emission was found in the antenna is vertical position.

LTE Band 4 QPSK 10MHz CH-Low, RB 1

Harmonic	Frequency (MHz)	SG (dBm)	Cable Loss (dB)	Gain (dBi)	Antenna Polarization	EIRP Level (dBm)	Limit (dBm)	Margin (dB)	Azimuth (deg)
2	3430.0	-55.35	2.6	10.15	Vertical	-47.8	-13.0	34.76	270
3	5145.0	-48.55	2.4	11.35	Vertical	-39.6	-13.0	26.56	45
4	6860.0	-54.65	4.5	10.85	Vertical	-48.3	-13.0	35.32	90
5	8575.0	-53.45	5.1	11.35	Vertical	-47.2	-13.0	34.18	180
6	10290.0	-49.15	5.3	11.95	Vertical	-42.5	-13.0	29.45	135
7	12005.0	-51.35	5.5	13.55	Vertical	-43.3	-13.0	30.29	225
8	13720.0	-47.05	6.3	13.75	Vertical	-39.6	-13.0	26.63	45
9	15435.0	-49.95	6.7	13.85	Vertical	-42.8	-13.0	29.85	135
10	17150.0	-48.35	6.8	14.25	Vertical	-40.9	-13.0	27.85	270

- Note: 1.The other Spurious RF Radiated emissions level is no more than noise floor.
2. The worst emission was found in the antenna is vertical position.



LTE Band 4 QPSK 10MHz CH-Middle, RB 1

Harmonic	Frequency (MHz)	SG (dBm)	Cable Loss (dB)	Gain (dBi)	Antenna Polarization	EIRP Level (dBm)	Limit (dBm)	Margin (dB)	Azimuth (deg)
2	3465.0	-62.85	2.6	10.75	Vertical	-54.7	-13.0	41.67	180
3	5197.5	-47.05	2.4	11.05	Vertical	-38.4	-13.0	25.44	315
4	6930.0	-54.95	4.5	11.15	Vertical	-48.3	-13.0	35.33	45
5	8662.5	-51.85	5.1	11.35	Vertical	-45.6	-13.0	32.61	135
6	10395.0	-48.75	5.3	11.95	Vertical	-42.1	-13.0	29.14	90
7	12127.5	-50.75	5.5	13.55	Vertical	-42.7	-13.0	29.69	225
8	13860.0	-47.05	6.3	13.75	Vertical	-39.6	-13.0	26.64	135
9	15592.5	-49.25	6.7	13.85	Vertical	-42.1	-13.0	29.13	180
10	17325.0	-46.55	6.8	14.25	Vertical	-39.1	-13.0	26.13	270

Note: 1.The other Spurious RF Radiated emissions level is no more than noise floor.

2. The worst emission was found in the antenna is vertical position.

LTE Band 4 QPSK 10MHz CH-High, RB 1

Harmonic	Frequency (MHz)	SG (dBm)	Cable Loss (dB)	Gain (dBi)	Antenna Polarization	EIRP Level (dBm)	Limit (dBm)	Margin (dB)	Azimuth (deg)
2	3500.0	-57.75	2.6	10.15	Vertical	-50.2	-13.0	37.16	45
3	5250.0	-49.55	2.4	11.05	Vertical	-40.9	-13.0	27.88	90
4	7000.0	-55.95	4.5	11.15	Vertical	-49.3	-13.0	36.25	180
5	8750.0	-53.05	5.1	11.35	Vertical	-46.8	-13.0	33.78	135
6	10500.0	-50.05	5.3	11.95	Vertical	-43.4	-13.0	30.36	225
7	12250.0	-50.35	5.5	13.55	Vertical	-42.3	-13.0	29.33	45
8	14000.0	-47.55	6.3	13.75	Vertical	-40.1	-13.0	27.10	135
9	15750.0	-47.65	6.7	13.85	Vertical	-40.5	-13.0	27.48	270
10	17500.0	-47.25	6.8	14.25	Vertical	-39.8	-13.0	26.81	180

Note: 1.The other Spurious RF Radiated emissions level is no more than noise floor.

2. The worst emission was found in the antenna is vertical position.

LTE Band 4 QPSK 15MHz CH Low, RB 1

Harmonic	Frequency (MHz)	SG (dBm)	Cable Loss (dB)	Gain (dBi)	Antenna Polarization	EIRP Level (dBm)	Limit (dBm)	Margin (dB)	Azimuth (deg)
2	3435.0	-55.15	2.6	10.15	Vertical	-47.6	-13.0	34.58	315
3	5152.5	-49.15	2.4	11.35	Vertical	-40.2	-13.0	27.16	45
4	6870.0	-55.45	4.5	10.85	Vertical	-49.1	-13.0	36.13	135
5	8587.5	-53.55	5.1	11.35	Vertical	-47.3	-13.0	34.28	90
6	10305.0	-49.15	5.3	11.95	Vertical	-42.5	-13.0	29.45	225
7	12022.5	-51.85	5.5	13.55	Vertical	-43.8	-13.0	30.76	135
8	13740.0	-47.05	6.3	13.75	Vertical	-39.6	-13.0	26.63	180
9	15457.5	-48.45	6.7	13.85	Vertical	-41.3	-13.0	28.35	270
10	17175.0	-46.85	6.8	14.25	Vertical	-39.4	-13.0	26.35	45

Note: 1.The other Spurious RF Radiated emissions level is no more than noise floor.

2. The worst emission was found in the antenna is vertical position.

LTE Band 4 QPSK 15MHz CH-Middle, RB 1

Harmonic	Frequency (MHz)	SG (dBm)	Cable Loss (dB)	Gain (dBi)	Antenna Polarization	EIRP Level (dBm)	Limit (dBm)	Margin (dB)	Azimuth (deg)
2	3465.0	-62.45	2.6	10.75	Vertical	-54.3	-13.0	41.30	90
3	5197.5	-49.85	2.4	11.05	Vertical	-41.2	-13.0	28.20	180
4	6930.0	-55.55	4.5	11.15	Vertical	-48.9	-13.0	35.86	135
5	8662.5	-50.85	5.1	11.35	Vertical	-44.6	-13.0	31.61	225
6	10395.0	-49.55	5.3	11.95	Vertical	-42.9	-13.0	29.91	45
7	12127.5	-49.35	5.5	13.55	Vertical	-41.3	-13.0	28.30	135
8	13860.0	-47.05	6.3	13.75	Vertical	-39.6	-13.0	26.64	270
9	15592.5	-49.25	6.7	13.85	Vertical	-42.1	-13.0	29.13	180
10	17325.0	-46.65	6.8	14.25	Vertical	-39.2	-13.0	26.23	315

Note: 1.The other Spurious RF Radiated emissions level is no more than noise floor.

2. The worst emission was found in the antenna is vertical position.

LTE Band 4 QPSK 15MHz CH-High, RB 1

Harmonic	Frequency (MHz)	SG (dBm)	Cable Loss (dB)	Gain (dBi)	Antenna Polarization	EIRP Level (dBm)	Limit (dBm)	Margin (dB)	Azimuth (deg)
2	3495.0	-59.35	2.6	10.15	Vertical	-51.8	-13.0	38.76	45
3	5242.5	-48.35	2.4	11.05	Vertical	-39.7	-13.0	26.73	135
4	6990.0	-54.95	4.5	11.15	Vertical	-48.3	-13.0	35.25	90
5	8737.5	-52.65	5.1	11.35	Vertical	-46.4	-13.0	33.36	225
6	10485.0	-50.05	5.3	11.95	Vertical	-43.4	-13.0	30.36	135
7	12232.5	-49.35	5.5	13.55	Vertical	-41.3	-13.0	28.33	180
8	13980.0	-47.55	6.3	13.75	Vertical	-40.1	-13.0	27.10	270
9	15727.5	-48.65	6.7	13.85	Vertical	-41.5	-13.0	28.48	45
10	17475.0	-46.75	6.8	14.25	Vertical	-39.3	-13.0	26.31	90

Note: 1.The other Spurious RF Radiated emissions level is no more than noise floor.

2. The worst emission was found in the antenna is vertical position.

LTE Band 4 QPSK 20MHz CH-Low, RB 1

Harmonic	Frequency (MHz)	SG (dBm)	Cable Loss (dB)	Gain (dBi)	Antenna Polarization	EIRP Level (dBm)	Limit (dBm)	Margin (dB)	Azimuth (deg)
2	3440.0	-63.25	2.6	10.15	Vertical	-55.7	-13.0	42.75	180
3	5160.0	-50.35	2.4	11.35	Vertical	-41.4	-13.0	28.38	135
4	6880.0	-54.65	4.5	10.85	Vertical	-48.3	-13.0	35.32	225
5	8600.0	-52.95	5.1	11.35	Vertical	-46.7	-13.0	33.68	45
6	10320.0	-49.15	5.3	11.95	Vertical	-42.5	-13.0	29.45	135
7	12040.0	-50.35	5.5	13.55	Vertical	-42.3	-13.0	29.29	270
8	13760.0	-47.05	6.3	13.75	Vertical	-39.6	-13.0	26.63	180
9	15480.0	-49.95	6.7	13.85	Vertical	-42.8	-13.0	29.85	315
10	17200.0	-47.35	6.8	14.25	Vertical	-39.9	-13.0	26.85	45

Note: 1.The other Spurious RF Radiated emissions level is no more than noise floor.

2. The worst emission was found in the antenna is vertical position.

LTE Band 4 QPSK 20MHz CH-Middle, RB 1

Harmonic	Frequency (MHz)	SG (dBm)	Cable Loss (dB)	Gain (dBi)	Antenna Polarization	EIRP Level (dBm)	Limit (dBm)	Margin (dB)	Azimuth (deg)
2	3465.0	-61.05	2.6	10.75	Vertical	-52.9	-13.0	39.92	135
3	5197.5	-51.25	2.4	11.05	Vertical	-42.6	-13.0	29.64	90
4	6930.0	-55.95	4.5	11.15	Vertical	-49.3	-13.0	36.27	225
5	8662.5	-51.85	5.1	11.35	Vertical	-45.6	-13.0	32.61	135
6	10395.0	-48.95	5.3	11.95	Vertical	-42.3	-13.0	29.31	180
7	12127.5	-50.35	5.5	13.55	Vertical	-42.3	-13.0	29.30	270
8	13860.0	-48.05	6.3	13.75	Vertical	-40.6	-13.0	27.64	45
9	15592.5	-49.25	6.7	13.85	Vertical	-42.1	-13.0	29.13	90
10	17325.0	-46.75	6.8	14.25	Vertical	-39.3	-13.0	26.32	180

Note: 1.The other Spurious RF Radiated emissions level is no more than noise floor.

2. The worst emission was found in the antenna is vertical position.

LTE Band 4 QPSK 20MHz CH-High, RB 1

Harmonic	Frequency (MHz)	SG (dBm)	Cable Loss (dB)	Gain (dBi)	Antenna Polarization	EIRP Level (dBm)	Limit (dBm)	Margin (dB)	Azimuth (deg)
2	3490.0	-58.75	2.6	10.15	Vertical	-51.2	-13.0	38.22	135
3	5235.0	-49.75	2.4	11.05	Vertical	-41.1	-13.0	28.10	225
4	6980.0	-54.95	4.5	11.15	Vertical	-48.3	-13.0	35.25	45
5	8725.0	-53.45	5.1	11.35	Vertical	-47.2	-13.0	34.18	135
6	10470.0	-50.05	5.3	11.95	Vertical	-43.4	-13.0	30.36	225
7	12215.0	-49.35	5.5	13.55	Vertical	-41.3	-13.0	28.33	180
8	13960.0	-47.55	6.3	13.75	Vertical	-40.1	-13.0	27.10	270
9	15705.0	-48.65	6.7	13.85	Vertical	-41.5	-13.0	28.48	45
10	17450.0	-46.75	6.8	14.25	Vertical	-39.3	-13.0	26.31	90

Note: 1.The other Spurious RF Radiated emissions level is no more than noise floor.

2. The worst emission was found in the antenna is vertical position.

LTE Band 7 QPSK 5MHz CH-Low, RB 1

Harmonic	Frequency (MHz)	SG (dBm)	Cable Loss (dB)	Gain (dBi)	Antenna Polarization	EIRP Level (dBm)	Limit (dBm)	Margin (dB)	Azimuth (deg)
2	5000.6	-55.55	2.00	9.15	Vertical	-48.4	-25.0	23.4	135
3	7501.1	-49.45	2.50	11.35	Vertical	-40.6	-25.0	15.6	180
4	10001.3	-50.95	4.20	12.05	Vertical	-43.1	-25.0	18.1	270
5	12512.5	-47.35	5.20	12.85	Vertical	-39.7	-25.0	14.7	45
6	15015.0	-47.13	5.50	14.23	Vertical	-38.4	-25.0	13.4	90
7	17517.5	-46.55	5.70	14.15	Vertical	-38.1	-25.0	13.1	225
8	20002.4	-45.06	6.30	13.76	Vertical	-37.6	-25.0	12.6	45
9	22502.7	-44.75	6.80	14.05	Vertical	-37.5	-25.0	12.5	135
10	25003.0	-44.54	6.90	14.84	Vertical	-36.6	-25.0	11.6	270

- Note: 1. The other Spurious RF Radiated emissions level is no more than noise floor.
 2. The worst emission was found in the antenna is vertical position.

LTE Band 7 QPSK 5MHz CH-Middle, RB 1

Harmonic	Frequency (MHz)	SG (dBm)	Cable Loss (dB)	Gain (dBi)	Antenna Polarization	EIRP Level (dBm)	Limit (dBm)	Margin (dB)	Azimuth (deg)
2	5065.8	-55.85	2.00	9.15	Vertical	-48.7	-25.0	23.7	180
3	7598.6	-53.55	2.50	11.35	Vertical	-44.7	-25.0	19.7	315
4	10130.6	-52.25	4.20	12.05	Vertical	-44.4	-25.0	19.4	45
5	12675.0	-47.25	5.20	12.85	Vertical	-39.6	-25.0	14.6	135
6	15210.0	-49.83	5.50	14.23	Vertical	-41.1	-25.0	16.1	90
7	17745.0	-46.55	5.70	14.15	Vertical	-38.1	-25.0	13.1	225
8	20280.0	-45.86	6.30	13.76	Vertical	-38.4	-25.0	13.4	135
9	22815.0	-44.85	6.80	14.05	Vertical	-37.6	-25.0	12.6	180
10	25350.0	-45.34	6.90	14.84	Vertical	-37.4	-25.0	12.4	270

- Note: 1. The other Spurious RF Radiated emissions level is no more than noise floor.
 2. The worst emission was found in the antenna is vertical position.

LTE Band 7 QPSK 5MHz CH-High, RB 1

Harmonic	Frequency (MHz)	SG (dBm)	Cable Loss (dB)	Gain (dBi)	Antenna Polarization	EIRP Level (dBm)	Limit (dBm)	Margin (dB)	Azimuth (deg)
2	5130.8	-55.25	2.00	9.15	Vertical	-48.1	-25.0	23.1	45
3	7696.1	-55.75	2.50	11.35	Vertical	-46.9	-25.0	21.9	90
4	10261.1	-49.75	4.20	12.05	Vertical	-41.9	-25.0	16.9	225
5	12837.5	-45.55	5.20	12.85	Vertical	-37.9	-25.0	12.9	45
6	15405.0	-50.03	5.50	14.23	Vertical	-41.3	-25.0	16.3	135
7	17972.5	-47.85	5.70	14.15	Vertical	-39.4	-25.0	14.4	270
8	20540.0	-46.06	6.30	13.76	Vertical	-38.6	-25.0	13.6	180
9	23107.5	-45.35	6.80	14.05	Vertical	-38.1	-25.0	13.1	315
10	25675.0	-45.64	6.90	14.84	Vertical	-37.7	-25.0	12.7	45

- Note: 1. The other Spurious RF Radiated emissions level is no more than noise floor.
 2. The worst emission was found in the antenna is vertical position.

LTE Band 7 QPSK 10MHz CH-Low, RB 1

Harmonic	Frequency (MHz)	SG (dBm)	Cable Loss (dB)	Gain (dBi)	Antenna Polarization	EIRP Level (dBm)	Limit (dBm)	Margin (dB)	Azimuth (deg)
2	5001.0	-56.75	2.00	9.15	Vertical	-49.6	-25.0	24.6	135
3	7515.0	-50.25	2.50	11.35	Vertical	-41.4	-25.0	16.4	90
4	10002.4	-51.65	4.20	12.05	Vertical	-43.8	-25.0	18.8	225
5	12525.0	-46.75	5.20	12.85	Vertical	-39.1	-25.0	14.1	135
6	15030.0	-49.23	5.50	14.23	Vertical	-40.5	-25.0	15.5	180
7	17535.0	-46.35	5.70	14.15	Vertical	-37.9	-25.0	12.9	270
8	20040.0	-45.66	6.30	13.76	Vertical	-38.2	-25.0	13.2	45
9	22545.0	-44.85	6.80	14.05	Vertical	-37.6	-25.0	12.6	90
10	25050.0	-45.04	6.90	14.84	Vertical	-37.1	-25.0	12.1	225

- Note: 1. The other Spurious RF Radiated emissions level is no more than noise floor.
 2. The worst emission was found in the antenna is vertical position.

LTE Band 7 QPSK 10MHz CH-Middle, RB 1

Harmonic	Frequency (MHz)	SG (dBm)	Cable Loss (dB)	Gain (dBi)	Antenna Polarization	EIRP Level (dBm)	Limit (dBm)	Margin (dB)	Azimuth (deg)
2	5070.0	-55.95	2.00	9.15	Vertical	-48.8	-25.0	23.8	45
3	75915.0	-53.85	2.50	11.35	Vertical	-45.0	-25.0	20.0	135
4	10140.0	-52.45	4.20	12.05	Vertical	-44.6	-25.0	19.6	270
5	12675.0	-50.15	5.20	12.85	Vertical	-42.5	-25.0	17.5	180
6	15210.0	-50.43	5.50	14.23	Vertical	-41.7	-25.0	16.7	315
7	17745.0	-46.75	5.70	14.15	Vertical	-38.3	-25.0	13.3	45
8	20280.0	-45.06	6.30	13.76	Vertical	-37.6	-25.0	12.6	135
9	22815.0	-45.35	6.80	14.05	Vertical	-38.1	-25.0	13.1	90
10	25350.0	-44.74	6.90	14.84	Vertical	-36.8	-25.0	11.8	225

- Note: 1.The other Spurious RF Radiated emissions level is no more than noise floor.
 2. The worst emission was found in the antenna is vertical position.

LTE Band 7 QPSK 10MHz CH-High, RB 1

Harmonic	Frequency (MHz)	SG (dBm)	Cable Loss (dB)	Gain (dBi)	Antenna Polarization	EIRP Level (dBm)	Limit (dBm)	Margin (dB)	Azimuth (deg)
2	5121.4	-54.35	2.00	10.15	Vertical	-46.2	-25.0	21.2	135
3	7681.9	-55.05	2.50	11.35	Vertical	-46.2	-25.0	21.2	180
4	10242.0	-51.95	4.20	12.05	Vertical	-44.1	-25.0	19.1	270
5	12825.0	-47.05	5.20	14.85	Vertical	-37.4	-25.0	12.4	45
6	15390.0	-48.83	5.50	13.23	Vertical	-41.1	-25.0	16.1	90
7	17955.0	-45.15	5.70	12.15	Vertical	-38.7	-25.0	13.7	225
8	20520.0	-44.76	6.30	13.76	Vertical	-37.3	-25.0	12.3	45
9	23085.0	-44.85	6.80	14.05	Vertical	-37.6	-25.0	12.6	135
10	25650.0	-45.64	6.90	14.84	Vertical	-37.7	-25.0	12.7	270

- Note: 1.The other Spurious RF Radiated emissions level is no more than noise floor.
 2. The worst emission was found in the antenna is vertical position.

LTE Band 7 QPSK 15MHz CH-Low, RB 1

Harmonic	Frequency (MHz)	SG (dBm)	Cable Loss (dB)	Gain (dBi)	Antenna Polarization	EIRP Level (dBm)	Limit (dBm)	Margin (dB)	Azimuth (deg)
2	5001.8	-56.95	2.00	10.15	Vertical	-48.8	-25.0	23.8	180
3	7502.6	-51.65	2.50	11.35	Vertical	-42.8	-25.0	17.8	315
4	1000.4	-53.25	4.20	12.05	Vertical	-45.4	-25.0	20.4	45
5	12537.5	-51.15	5.20	14.85	Vertical	-41.5	-25.0	16.5	135
6	15045.0	-48.03	5.50	13.23	Vertical	-40.3	-25.0	15.3	90
7	17552.5	-45.55	5.70	12.15	Vertical	-39.1	-25.0	14.1	225
8	20060.0	-46.16	6.30	13.76	Vertical	-38.7	-25.0	13.7	135
9	22567.5	-45.35	6.80	14.05	Vertical	-38.1	-25.0	13.1	180
10	25075.0	-45.54	6.90	14.84	Vertical	-37.6	-25.0	12.6	270

Note: 1.The other Spurious RF Radiated emissions level is no more than noise floor.

2. The worst emission was found in the antenna is vertical position.

LTE Band 7 QPSK 15MHz CH-Middle, RB 1

Harmonic	Frequency (MHz)	SG (dBm)	Cable Loss (dB)	Gain (dBi)	Antenna Polarization	EIRP Level (dBm)	Limit (dBm)	Margin (dB)	Azimuth (deg)
2	5056.9	-56.75	2.00	10.15	Vertical	-48.6	-25.0	23.6	45
3	7584.8	-55.35	2.50	11.35	Vertical	-46.5	-25.0	21.5	90
4	10140.0	-50.95	4.20	12.05	Vertical	-43.1	-25.0	18.1	225
5	12675.0	-51.05	5.20	14.85	Vertical	-41.4	-25.0	16.4	45
6	15210.0	-49.03	5.50	13.23	Vertical	-41.3	-25.0	16.3	135
7	17745.0	-44.45	5.70	12.15	Vertical	-38.0	-25.0	13.0	270
8	20280.0	-44.66	6.30	13.76	Vertical	-37.2	-25.0	12.2	180
9	22815.0	-43.85	6.80	14.05	Vertical	-36.6	-25.0	11.6	315
10	25350.0	-45.04	6.90	14.84	Vertical	-37.1	-25.0	12.1	45

Note: 1.The other Spurious RF Radiated emissions level is no more than noise floor.

2. The worst emission was found in the antenna is vertical position.

LTE Band 7 QPSK 15MHz CH-High, RB 1

Harmonic	Frequency (MHz)	SG (dBm)	Cable Loss (dB)	Gain (dBi)	Antenna Polarization	EIRP Level (dBm)	Limit (dBm)	Margin (dB)	Azimuth (deg)
2	5112.0	-54.75	2.00	10.15	Vertical	-46.6	-25.0	21.6	135
3	7667.3	-55.65	2.50	11.35	Vertical	-46.8	-25.0	21.8	90
4	10250.0	-52.65	4.20	12.05	Vertical	-44.8	-25.0	19.8	225
5	12812.5	-48.35	5.20	14.85	Vertical	-38.7	-25.0	13.7	135
6	15375.0	-48.53	5.50	13.23	Vertical	-40.8	-25.0	15.8	180
7	17937.5	-43.95	5.70	12.15	Vertical	-37.5	-25.0	12.5	270
8	20500.0	-44.56	6.30	13.76	Vertical	-37.1	-25.0	12.1	45
9	23062.5	-43.65	6.80	14.05	Vertical	-36.4	-25.0	11.4	90
10	25625.0	-44.74	6.90	14.84	Vertical	-36.8	-25.0	11.8	225

- Note: 1.The other Spurious RF Radiated emissions level is no more than noise floor.
 2. The worst emission was found in the antenna is vertical position.

LTE Band 7 QPSK 20MHz CH-Low, RB 1

Harmonic	Frequency (MHz)	SG (dBm)	Cable Loss (dB)	Gain (dBi)	Antenna Polarization	EIRP Level (dBm)	Limit (dBm)	Margin (dB)	Azimuth (deg)
2	5002.5	-56.85	2.00	10.15	Vertical	-48.7	-25.0	23.7	45
3	7503.4	-51.05	2.50	11.35	Vertical	-42.2	-25.0	17.2	135
4	10040.0	-52.25	4.20	12.05	Vertical	-44.4	-25.0	19.4	270
5	12550.0	-51.55	5.20	14.85	Vertical	-41.9	-25.0	16.9	180
6	15060.0	-48.93	5.50	13.23	Vertical	-41.2	-25.0	16.2	315
7	17570.0	-44.95	5.70	12.15	Vertical	-38.5	-25.0	13.5	45
8	20080.0	-45.06	6.30	13.76	Vertical	-37.6	-25.0	12.6	135
9	22590.0	-44.45	6.80	14.05	Vertical	-37.2	-25.0	12.2	90
10	25100.0	-44.24	6.90	14.84	Vertical	-36.3	-25.0	11.3	225

- Note: 1.The other Spurious RF Radiated emissions level is no more than noise floor.
 2. The worst emission was found in the antenna is vertical position.

LTE Band 7 QPSK 20MHz CH-Middle, RB 1

Harmonic	Frequency (MHz)	SG (dBm)	Cable Loss (dB)	Gain (dBi)	Antenna Polarization	EIRP Level (dBm)	Limit (dBm)	Margin (dB)	Azimuth (deg)
2	5052.0	-55.85	2.00	10.15	Vertical	-47.7	-25.0	22.7	135
3	7578.0	-54.05	2.50	11.35	Vertical	-45.2	-25.0	20.2	180
4	10140.0	-52.05	4.20	12.05	Vertical	-44.2	-25.0	19.2	270
5	12675.0	-50.85	5.20	14.85	Vertical	-41.2	-25.0	16.2	45
6	15210.0	-49.43	5.50	13.23	Vertical	-41.7	-25.0	16.7	90
7	17745.0	-44.25	5.70	12.15	Vertical	-37.8	-25.0	12.8	225
8	20280.0	-45.76	6.30	13.76	Vertical	-38.3	-25.0	13.3	45
9	22815.0	-44.35	6.80	14.05	Vertical	-37.1	-25.0	12.1	135
10	25350.0	-44.84	6.90	14.84	Vertical	-36.9	-25.0	11.9	270

- Note: 1.The other Spurious RF Radiated emissions level is no more than noise floor.
 2. The worst emission was found in the antenna is vertical position.

LTE Band 7 QPSK 20MHz CH-High, RB 1

Harmonic	Frequency (MHz)	SG (dBm)	Cable Loss (dB)	Gain (dBi)	Antenna Polarization	EIRP Level (dBm)	Limit (dBm)	Margin (dB)	Azimuth (deg)
2	5102.3	-54.85	2.00	10.15	Vertical	-46.7	-25.0	21.7	180
3	7653.4	-55.05	2.50	11.35	Vertical	-46.2	-25.0	21.2	315
4	10240.0	-52.35	4.20	12.05	Vertical	-44.5	-25.0	19.5	45
5	12800.0	-51.35	5.20	14.85	Vertical	-41.7	-25.0	16.7	135
6	15360.0	-49.03	5.50	13.23	Vertical	-41.3	-25.0	16.3	90
7	17920.0	-45.15	5.70	12.15	Vertical	-38.7	-25.0	13.7	225
8	20480.0	-45.36	6.30	13.76	Vertical	-37.9	-25.0	12.9	135
9	23040.0	-44.85	6.80	14.05	Vertical	-37.6	-25.0	12.6	180
10	25600.0	-44.84	6.90	14.84	Vertical	-36.9	-25.0	11.9	270

- Note: 1.The other Spurious RF Radiated emissions level is no more than noise floor.
 2. The worst emission was found in the antenna is vertical position.

LTE Band 38 QPSK 5MHz CH-Low, RB 1

Harmonic	Frequency (MHz)	SG (dBm)	Cable Loss (dB)	Gain (dBi)	Antenna Polarization	EIRP Level (dBm)	Limit (dBm)	Margin (dB)	Azimuth (deg)
2	5145.0	-55.05	2.00	9.15	Vertical	-47.9	-25.0	22.9	225
3	7717.5	-54.75	2.50	11.35	Vertical	-45.9	-25.0	20.9	45
4	10290.0	-51.55	4.20	12.05	Vertical	-43.7	-25.0	18.7	135
5	12862.5	-49.75	5.20	12.85	Vertical	-42.1	-25.0	17.1	270
6	15435.0	-50.03	5.50	14.23	Vertical	-41.3	-25.0	16.3	180
7	18007.5	-48.65	5.70	14.15	Vertical	-40.2	-25.0	15.2	315
8	20580.0	-47.06	6.30	13.76	Vertical	-39.6	-25.0	14.6	45
9	23152.5	-45.85	6.80	14.05	Vertical	-38.6	-25.0	13.6	135
10	25725.0	29.76	6.90	14.84	Vertical	37.7	-25.0	-62.7	90

Note: 1.The other Spurious RF Radiated emissions level is no more than noise floor.

2. The worst emission was found in the antenna is vertical position.

LTE Band 38 QPSK 5MHz CH-Middle, RB 1

Harmonic	Frequency (MHz)	SG (dBm)	Cable Loss (dB)	Gain (dBi)	Antenna Polarization	EIRP Level (dBm)	Limit (dBm)	Margin (dB)	Azimuth (deg)
2	5190.0	-54.85	2.00	9.15	Vertical	-47.7	-25.0	22.7	225
3	7785.0	-57.65	2.50	11.35	Vertical	-48.8	-25.0	23.8	135
4	10380.0	-51.25	4.20	12.05	Vertical	-43.4	-25.0	18.4	180
5	12975.0	-48.55	5.20	12.85	Vertical	-40.9	-25.0	15.9	270
6	15570.0	-50.53	5.50	14.23	Vertical	-41.8	-25.0	16.8	45
7	18165.0	-48.75	5.70	14.15	Vertical	-40.3	-25.0	15.3	90
8	20760.0	-46.06	6.30	13.76	Vertical	-38.6	-25.0	13.6	225
9	23355.0	-44.95	6.80	14.05	Vertical	-37.7	-25.0	12.7	45
10	25950.0	-44.84	6.90	14.84	Vertical	-36.9	-25.0	11.9	135

Note: 1.The other Spurious RF Radiated emissions level is no more than noise floor.

2. The worst emission was found in the antenna is vertical position.

LTE Band 38 QPSK 5MHz CH-High, RB 1

Harmonic	Frequency (MHz)	SG (dBm)	Cable Loss (dB)	Gain (dBi)	Antenna Polarization	EIRP Level (dBm)	Limit (dBm)	Margin (dB)	Azimuth (deg)
2	5235.0	-56.35	2.00	9.15	Vertical	-49.2	-25.0	24.2	270
3	7852.5	-53.55	2.50	11.35	Vertical	-44.7	-25.0	19.7	180
4	10470.0	-51.35	4.20	12.05	Vertical	-43.5	-25.0	18.5	225
5	13087.5	-46.95	5.20	12.85	Vertical	-39.3	-25.0	14.3	45
6	15705.0	-49.13	5.50	14.23	Vertical	-40.4	-25.0	15.4	135
7	18322.5	-48.15	5.70	14.15	Vertical	-39.7	-25.0	14.7	270
8	20940.0	-45.56	6.30	13.76	Vertical	-38.1	-25.0	13.1	180
9	23557.5	-44.95	6.80	14.05	Vertical	-37.7	-25.0	12.7	315
10	26175.0	-45.04	6.90	14.84	Vertical	-37.1	-25.0	12.1	45

Note: 1.The other Spurious RF Radiated emissions level is no more than noise floor.

2. The worst emission was found in the antenna is vertical position.

LTE Band 38 QPSK 10MHz CH-Low, RB 1

Harmonic	Frequency (MHz)	SG (dBm)	Cable Loss (dB)	Gain (dBi)	Antenna Polarization	EIRP Level (dBm)	Limit (dBm)	Margin (dB)	Azimuth (deg)
2	5150.0	-54.45	2.00	9.15	Vertical	-47.3	-25.0	22.3	135
3	7725.0	-52.55	2.50	11.35	Vertical	-43.7	-25.0	18.7	90
4	10300.0	-50.85	4.20	12.05	Vertical	-43.0	-25.0	18.0	225
5	12875.0	-47.85	5.20	12.85	Vertical	-40.2	-25.0	15.2	135
6	15450.0	-48.93	5.50	14.23	Vertical	-40.2	-25.0	15.2	180
7	18025.0	-47.05	5.70	14.15	Vertical	-38.6	-25.0	13.6	270
8	20600.0	-46.56	6.30	13.76	Vertical	-39.1	-25.0	14.1	45
9	23175.0	-45.55	6.80	14.05	Vertical	-38.3	-25.0	13.3	90
10	25750.0	-45.54	6.90	14.84	Vertical	-37.6	-25.0	12.6	225

Note: 1.The other Spurious RF Radiated emissions level is no more than noise floor.

2. The worst emission was found in the antenna is vertical position.

LTE Band 38 QPSK 10MHz CH-Middle, RB 1

Harmonic	Frequency (MHz)	SG (dBm)	Cable Loss (dB)	Gain (dBi)	Antenna Polarization	EIRP Level (dBm)	Limit (dBm)	Margin (dB)	Azimuth (deg)
2	5190.0	-56.55	2.00	9.15	Vertical	-49.4	-25.0	24.4	45
3	7785.0	-55.55	2.50	11.35	Vertical	-46.7	-25.0	21.7	135
4	10380.0	-51.55	4.20	12.05	Vertical	-43.7	-25.0	18.7	270
5	12975.0	-48.65	5.20	12.85	Vertical	-41.0	-25.0	16.0	180
6	15570.0	-51.13	5.50	14.23	Vertical	-42.4	-25.0	17.4	45
7	18165.0	-49.85	5.70	14.15	Vertical	-41.4	-25.0	16.4	135
8	20760.0	-47.56	6.30	13.76	Vertical	-40.1	-25.0	15.1	270
9	23355.0	-47.05	6.80	14.05	Vertical	-39.8	-25.0	14.8	180
10	25950.0	-45.54	6.90	14.84	Vertical	-37.6	-25.0	12.6	315

Note: 1.The other Spurious RF Radiated emissions level is no more than noise floor.

2. The worst emission was found in the antenna is vertical position.

LTE Band 38 QPSK 10MHz CH-High, RB 1

Harmonic	Frequency (MHz)	SG (dBm)	Cable Loss (dB)	Gain (dBi)	Antenna Polarization	EIRP Level (dBm)	Limit (dBm)	Margin (dB)	Azimuth (deg)
2	5230.0	-57.35	2.00	10.15	Vertical	-49.2	-25.0	24.2	45
3	7845.0	-55.15	2.50	11.35	Vertical	-46.3	-25.0	21.3	135
4	10460.0	-51.25	4.20	12.05	Vertical	-43.4	-25.0	18.4	90
5	13075.0	-50.65	5.20	14.85	Vertical	-41.0	-25.0	16.0	225
6	15690.0	-49.23	5.50	13.23	Vertical	-41.5	-25.0	16.5	135
7	18305.0	-46.85	5.70	12.15	Vertical	-40.4	-25.0	15.4	180
8	20920.0	-47.06	6.30	13.76	Vertical	-39.6	-25.0	14.6	270
9	23535.0	-46.35	6.80	14.05	Vertical	-39.1	-25.0	14.1	45
10	26150.0	-46.64	6.90	14.84	Vertical	-38.7	-25.0	13.7	90

Note: 1.The other Spurious RF Radiated emissions level is no more than noise floor.

2. The worst emission was found in the antenna is vertical position.

LTE Band 38 QPSK 15MHz CH-Low, RB 1

Harmonic	Frequency (MHz)	SG (dBm)	Cable Loss (dB)	Gain (dBi)	Antenna Polarization	EIRP Level (dBm)	Limit (dBm)	Margin (dB)	Azimuth (deg)
2	5155.0	-53.45	2.00	10.15	Vertical	-45.3	-25.0	20.3	225
3	7732.5	-54.65	2.50	11.35	Vertical	-45.8	-25.0	20.8	45
4	10310.0	-50.35	4.20	12.05	Vertical	-42.5	-25.0	17.5	45
5	12887.5	-50.45	5.20	14.85	Vertical	-40.8	-25.0	15.8	135
6	15465.0	-48.63	5.50	13.23	Vertical	-40.9	-25.0	15.9	270
7	18042.5	-46.05	5.70	12.15	Vertical	-39.6	-25.0	14.6	180
8	20620.0	-46.06	6.30	13.76	Vertical	-38.6	-25.0	13.6	315
9	23197.5	-44.45	6.80	14.05	Vertical	-37.2	-25.0	12.2	45
10	25775.0	-45.04	6.90	14.84	Vertical	-37.1	-25.0	12.1	135

Note: 1.The other Spurious RF Radiated emissions level is no more than noise floor.

2. The worst emission was found in the antenna is vertical position.

LTE Band 38 QPSK 15MHz CH-Middle, RB 1

Harmonic	Frequency (MHz)	SG (dBm)	Cable Loss (dB)	Gain (dBi)	Antenna Polarization	EIRP Level (dBm)	Limit (dBm)	Margin (dB)	Azimuth (deg)
2	5190.0	-57.75	2.00	10.15	Vertical	-49.6	-25.0	24.6	90
3	7785.0	-55.55	2.50	11.35	Vertical	-46.7	-25.0	21.7	225
4	10380.0	-51.65	4.20	12.05	Vertical	-43.8	-25.0	18.8	135
5	12975.0	-50.35	5.20	14.85	Vertical	-40.7	-25.0	15.7	180
6	15570.0	-48.63	5.50	13.23	Vertical	-40.9	-25.0	15.9	270
7	18165.0	-46.15	5.70	12.15	Vertical	-39.7	-25.0	14.7	45
8	20760.0	-45.96	6.30	13.76	Vertical	-38.5	-25.0	13.5	90
9	23355.0	-44.75	6.80	14.05	Vertical	-37.5	-25.0	12.5	225
10	25950.0	-45.24	6.90	14.84	Vertical	-37.3	-25.0	12.3	45

Note: 1.The other Spurious RF Radiated emissions level is no more than noise floor.

2. The worst emission was found in the antenna is vertical position.

LTE Band 38 QPSK 15MHz CH-High, RB 1

Harmonic	Frequency (MHz)	SG (dBm)	Cable Loss (dB)	Gain (dBi)	Antenna Polarization	EIRP Level (dBm)	Limit (dBm)	Margin (dB)	Azimuth (deg)
2	5225.0	-56.05	2.00	10.15	Vertical	-47.9	-25.0	22.9	135
3	7837.5	-54.75	2.50	11.35	Vertical	-45.9	-25.0	20.9	270
4	10450.0	-51.05	4.20	12.05	Vertical	-43.2	-25.0	18.2	180
5	13062.5	-49.85	5.20	14.85	Vertical	-40.2	-25.0	15.2	315
6	15675.0	-48.43	5.50	13.23	Vertical	-40.7	-25.0	15.7	45
7	18287.5	-46.35	5.70	12.15	Vertical	-39.9	-25.0	14.9	135
8	20900.0	-46.76	6.30	13.76	Vertical	-39.3	-25.0	14.3	90
9	23512.5	-45.35	6.80	14.05	Vertical	-38.1	-25.0	13.1	225
10	26125.0	-45.84	6.90	14.84	Vertical	-37.9	-25.0	12.9	135

Note: 1.The other Spurious RF Radiated emissions level is no more than noise floor.

2. The worst emission was found in the antenna is vertical position.

LTE Band 38 QPSK 20MHz CH-Low, RB 1

Harmonic	Frequency (MHz)	SG (dBm)	Cable Loss (dB)	Gain (dBi)	Antenna Polarization	EIRP Level (dBm)	Limit (dBm)	Margin (dB)	Azimuth (deg)
2	5160.0	-54.85	2.00	10.15	Vertical	-46.7	-25.0	21.7	180
3	7740.0	-56.65	2.50	11.35	Vertical	-47.8	-25.0	22.8	270
4	10320.0	-51.65	4.20	12.05	Vertical	-43.8	-25.0	18.8	45
5	12900.0	-50.35	5.20	14.85	Vertical	-40.7	-25.0	15.7	90
6	15480.0	-48.53	5.50	13.23	Vertical	-40.8	-25.0	15.8	225
7	18060.0	-46.55	5.70	12.15	Vertical	-40.1	-25.0	15.1	45
8	20640.0	-46.96	6.30	13.76	Vertical	-39.5	-25.0	14.5	135
9	23220.0	-45.55	6.80	14.05	Vertical	-38.3	-25.0	13.3	270
10	25800.0	-45.34	6.90	14.84	Vertical	-37.4	-25.0	12.4	180

Note: 1.The other Spurious RF Radiated emissions level is no more than noise floor.

2. The worst emission was found in the antenna is vertical position.

LTE Band 38 QPSK 20MHz CH-Middle, RB 1

Harmonic	Frequency (MHz)	SG (dBm)	Cable Loss (dB)	Gain (dBi)	Antenna Polarization	EIRP Level (dBm)	Limit (dBm)	Margin (dB)	Azimuth (deg)
2	5190.0	-57.15	2.00	10.15	Vertical	-49.0	-25.0	24.0	315
3	7785.0	-54.85	2.50	11.35	Vertical	-46.0	-25.0	21.0	45
4	10380.0	-51.75	4.20	12.05	Vertical	-43.9	-25.0	18.9	135
5	12975.0	-50.45	5.20	14.85	Vertical	-40.8	-25.0	15.8	90
6	15570.0	-48.43	5.50	13.23	Vertical	-40.7	-25.0	15.7	225
7	18165.0	-46.85	5.70	12.15	Vertical	-40.4	-25.0	15.4	135
8	20760.0	-45.86	6.30	13.76	Vertical	-38.4	-25.0	13.4	180
9	23355.0	-46.75	6.80	14.05	Vertical	-39.5	-25.0	14.5	270
10	25950.0	-46.14	6.90	14.84	Vertical	-38.2	-25.0	13.2	45

Note: 1.The other Spurious RF Radiated emissions level is no more than noise floor.

2. The worst emission was found in the antenna is vertical position.

LTE Band 38 QPSK 20MHz CH-High, RB 1

Harmonic	Frequency (MHz)	SG (dBm)	Cable Loss (dB)	Gain (dBi)	Antenna Polarization	EIRP Level (dBm)	Limit (dBm)	Margin (dB)	Azimuth (deg)
2	5220.0	-57.25	2.00	10.15	Vertical	-49.1	-25.0	24.1	90
3	7830.0	-54.75	2.50	11.35	Vertical	-45.9	-25.0	20.9	225
4	10440.0	-51.25	4.20	12.05	Vertical	-43.4	-25.0	18.4	45
5	13050.0	-49.85	5.20	14.85	Vertical	-40.2	-25.0	15.2	135
6	15660.0	-48.63	5.50	13.23	Vertical	-40.9	-25.0	15.9	270
7	18270.0	-46.85	5.70	12.15	Vertical	-40.4	-25.0	15.4	180
8	20880.0	-47.06	6.30	13.76	Vertical	-39.6	-25.0	14.6	315
9	23490.0	-46.05	6.80	14.05	Vertical	-38.8	-25.0	13.8	45
10	26100.0	-45.34	6.90	14.84	Vertical	-37.4	-25.0	12.4	135

Note: 1.The other Spurious RF Radiated emissions level is no more than noise floor.

2. The worst emission was found in the antenna is vertical position.

6 Main Test Instruments

Name	Manufacturer	Type	Serial Number	Calibration Date	Expiration Time
Base Station Simulator	R&S	CMW500	113645	2017-05-14	2018-05-13
Power Splitter	Hua Xiang	SHX-GF2-2-13	10120101	2017-05-14	2018-05-13
Spectrum Analyzer	Agilent	N9010A	MY47191109	2017-05-14	2018-05-13
Signal Analyzer	R&S	FSV30	100815	2016-12-16	2017-12-15
Signal generator	R&S	SMB 100A	102594	2017-05-14	2018-05-13
EMI Test Receiver	R&S	ESCI	100948	2017-05-20	2018-05-19
Trilog Antenna	SCHWARZBECK	VUBL 9163	9163-201	2014-12-06	2017-12-05
Horn Antenna	R&S	HF907	100126	2014-12-06	2017-12-05
Horn Antenna	ETS-Lindgren	3160-09	00102643	2015-01-30	2018-01-29
Climatic Chamber	Re Ce	PT-30B	20101891	2015-07-18	2018-07-17
RF Cable	Agilent	SMA 15cm	0001	2017-08-04	2018-02-03
Preamplifier	R&S	SCU18	102327	2017-06-18	2018-06-17

ANNEX A: EUT Appearance and Test Setup

A.1 EUT Appearance



Front Side



Back Side

a: EUT



Adapter 1



Adapter 2
b: Adapter

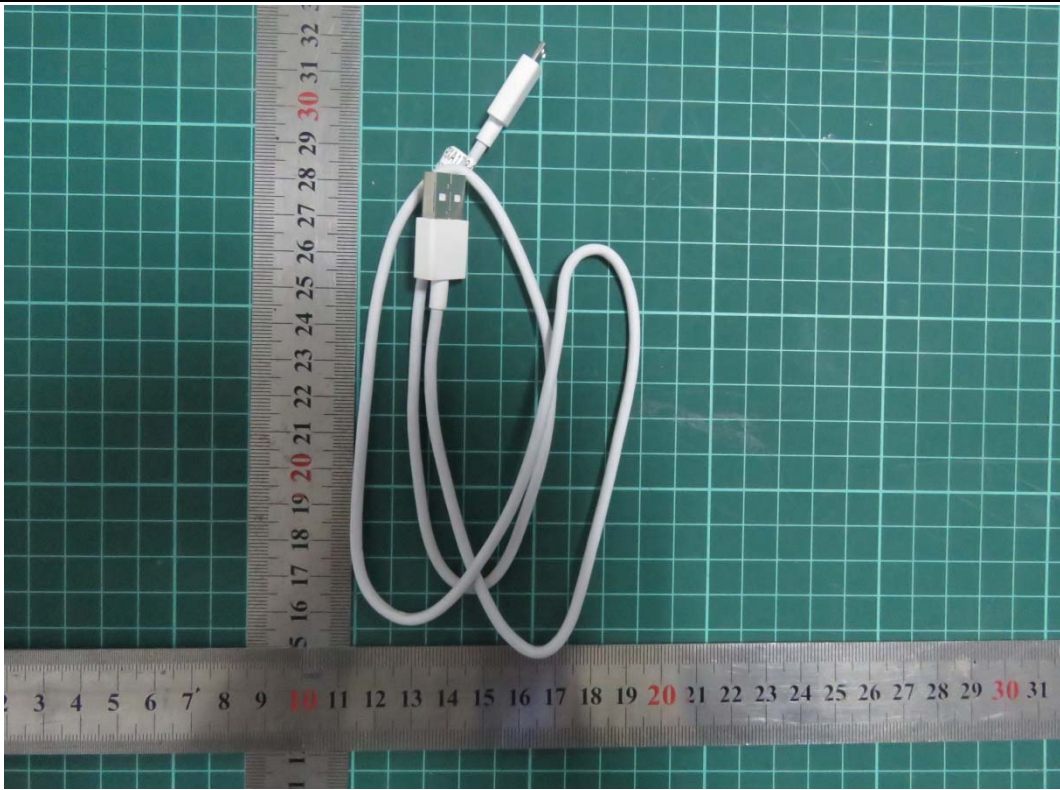

c : USB Cable

Picture 1 EUT and Accessory

A.2 Test Setup

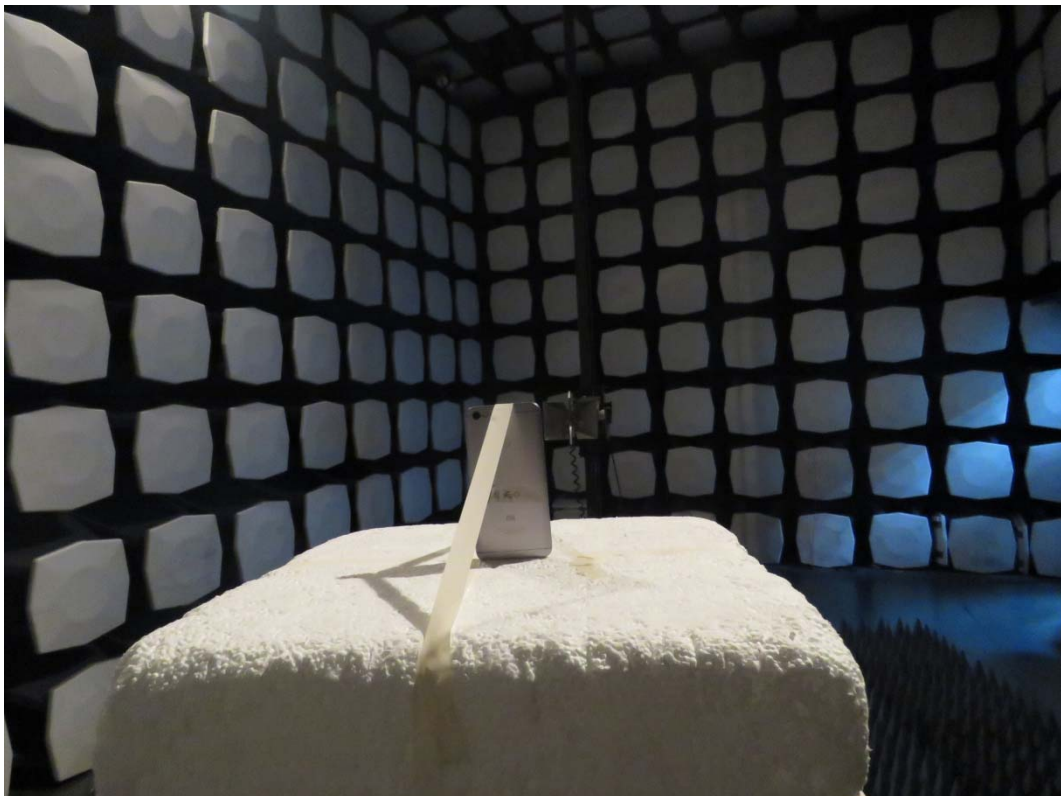
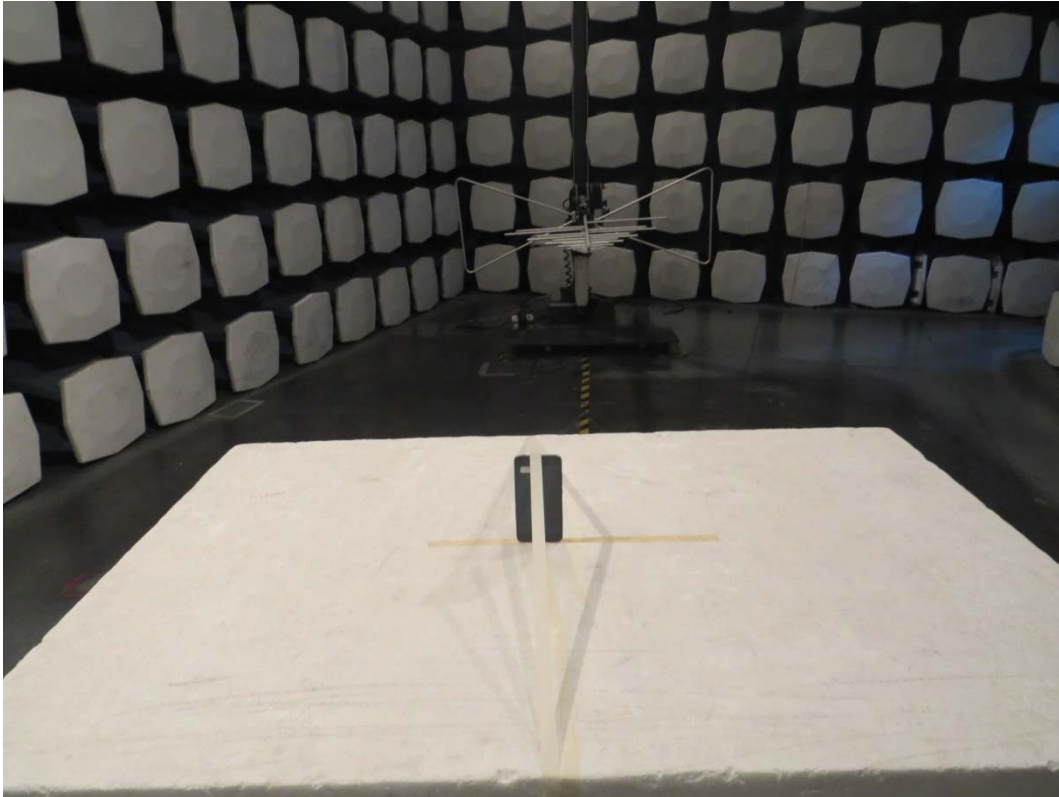

Picture 2: Radiated Spurious Emissions Test setup