

FCC SAR Test Report

APPLICANT : Xiaomi Communications Co., Ltd.
EQUIPMENT : Mobile Phone
BRAND NAME : MI
MODEL NAME : M1806E7TG
FCC ID : 2AFZZ-RMSE7TG
STANDARD : FCC 47 CFR Part 2 (2.1093)
ANSI/IEEE C95.1-1992
IEEE 1528-2013

We, Sporton International (Kunshan) Inc., would like to declare that the tested sample has been evaluated in accordance with the procedures and had been in compliance with the applicable technical standards.

The test results in this report apply exclusively to the tested model / sample. Without written approval of Sporton International (Kunshan) Inc., the test report shall not be reproduced except in full.



Approved by: Mark Qu / Manager



Sporton International (Kunshan) Inc.

No.3-2 Ping-Xiang Rd, Kunshan Development Zone Kunshan City Jiangsu Province 215335 China



Table of Contents

1. Statement of Compliance 4
2. Administration Data 5
3. Guidance Applied..... 5
4. Equipment Under Test (EUT) Information 6
4.1 General Information 6
4.2 General LTE SAR Test and Reporting Considerations 8
5. Proximity Sensor Triggering Test.....10
5.1 Proximity sensor triggering distances(Per KDB616217§6.2)10
6. RF Exposure Limits.....19
6.1 Uncontrolled Environment.....19
6.2 Controlled Environment.....19
7. Specific Absorption Rate (SAR).....20
7.1 Introduction20
7.2 SAR Definition.....20
8. System Description and Setup21
8.1 E-Field Probe22
8.2 Data Acquisition Electronics (DAE)22
8.3 Phantom.....23
8.4 Device Holder.....24
9. Measurement Procedures25
9.1 Spatial Peak SAR Evaluation.....25
9.2 Power Reference Measurement.....26
9.3 Area Scan26
9.4 Zoom Scan.....27
9.5 Volume Scan Procedures.....27
9.6 Power Drift Monitoring.....27
10. Test Equipment List.....28
11. System Verification29
11.1 Tissue Simulating Liquids29
11.2 Tissue Verification30
11.3 System Performance Check Results31
12. RF Exposure Positions32
12.1 Ear and handset reference point32
12.2 Definition of the cheek position33
12.3 Definition of the tilt position34
12.4 Body Worn Accessory35
12.5 Product Specific 10g SAR Exposure36
12.6 Wireless Router.....36
13. Conducted RF Output Power (Unit: dBm).....37
14. Antenna Location80
15. SAR Test Results82
15.1 Head SAR85
15.2 Hotspot SAR89
15.3 Body Worn Accessory SAR94
15.4 Product specific 10g SAR97
15.5 Repeated SAR Measurement98
16. Simultaneous Transmission Analysis99
16.1 Head Exposure Conditions100
16.2 Hotspot Exposure Conditions.....102
16.3 Body-Worn Accessory Exposure Conditions104
17. Uncertainty Assessment105
18. References.....106
Appendix A. Plots of System Performance Check
Appendix B. Plots of High SAR Measurement
Appendix C. DASY Calibration Certificate
Appendix D. Test Setup Photos



Revision History

REPORT NO.	VERSION	DESCRIPTION	ISSUED DATE
FA862604	Rev. 01	Initial issue of report	Aug. 02, 2018



1. Statement of Compliance

The maximum results of Specific Absorption Rate (SAR) found during testing for **Xiaomi Communications Co., Ltd., Mobile Phone, M1806E7TG**, are as follows.

Highest 1g SAR Summary						
Equipment Class	Frequency Band		Head (Separation 0mm)	Hotspot (Separation 10mm)	Body-worn (Separation 10mm)	Highest Simultaneous Transmission 1g SAR (W/kg)
			1g SAR (W/kg)			
Licensed	GSM	GSM850	0.40	0.23	0.23	1.47
		GSM1900	0.64	0.56	0.47	
	WCDMA	Band V	0.27	0.13	0.13	
		Band IV	0.63	1.14	0.78	
		Band II	0.72	0.56	0.47	
	LTE	Band 5	0.27	0.15	0.15	
		Band 4	0.53	0.89	0.71	
		Band 7	0.75	0.24	0.19	
	Band 38	0.62	0.22	0.14		
DTS	WLAN	2.4GHz WLAN	0.65	0.21	0.21	1.40
NII		5GHz WLAN	0.72	0.29	0.21	1.47
DSS	Bluetooth	2.4GHz Bluetooth	<0.10	<0.10	<0.10	1.14
Highest 10g SAR Summary						
Equipment Class	Frequency Band		Product Specific 10g SAR (W/kg) (Separation 0mm)			
NII	WLAN	5GHz WLAN	0.70			
Date of Testing:			2018/7/4 ~ 2018/7/10			

This device is in compliance with Specific Absorption Rate (SAR) for general population/uncontrolled exposure limits (1.6 W/kg for Partial-Body 1g SAR, 4.0 W/kg for Product Specific 10g SAR) specified in FCC 47 CFR part 2 (2.1093) and ANSI/IEEE C95.1-1992, and had been tested in accordance with the measurement methods and procedures specified in IEEE 1528-2013 and FCC KDB publications.



2. Administration Data

Testing Laboratory	
Test Site	Sporton International (Kunshan) Inc.
Test Site Location	No.3-2 Ping-Xiang Rd, Kunshan Development Zone Kunshan City Jiangsu Province 215335 China TEL : +86-512-57900158 FAX : +86-512-57900958

Applicant	
Company Name	Xiaomi Communications Co., Ltd.
Address	The Rainbow City of China Resources, NO.68, Qinghe Middle Street, Haidian District, Beijing, China

Manufacturer	
Company Name	Xiaomi Communications Co., Ltd.
Address	The Rainbow City of China Resources, NO.68, Qinghe Middle Street, Haidian District, Beijing, China

3. Guidance Applied

The Specific Absorption Rate (SAR) testing specification, method, and procedure for this device is in accordance with the following standards:

- FCC 47 CFR Part 2 (2.1093)
- ANSI/IEEE C95.1-1992
- IEEE 1528-2013
- FCC KDB 865664 D01 SAR Measurement 100 MHz to 6 GHz v01r04
- FCC KDB 865664 D02 SAR Reporting v01r02
- FCC KDB 447498 D01 General RF Exposure Guidance v06
- FCC KDB 648474 D04 SAR Evaluation Considerations for Wireless Handsets v01r03
- FCC KDB 248227 D01 802.11 Wi-Fi SAR v02r02
- FCC KDB 941225 D01 3G SAR Procedures v03r01
- FCC KDB 941225 D05 SAR for LTE Devices v02r05
- FCC KDB 941225 D05A Rel.10 LTE SAR Test Guidance v01r02
- FCC KDB 941225 D06 Hotspot Mode SAR v02r01
- FCC KDB 616217 D04 SAR for laptop and tablets v01r02



4. Equipment Under Test (EUT) Information

4.1 General Information

Product Feature & Specification	
Equipment Name	Mobile Phone
Brand Name	MI
Model Name	M1806E7TG
FCC ID	2AFZZ-RMSE7TG
IMEI Code	SIM1: 867601030224860 SIM2: 867601030226093
Wireless Technology and Frequency Range	GSM850: 824.2 MHz ~ 848.8 MHz GSM1900: 1850.2 MHz ~ 1909.8 MHz WCDMA Band II: 1852.4 MHz ~ 1907.6 MHz WCDMA Band IV: 1712.4 MHz ~ 1752.6 MHz WCDMA Band V: 826.4 MHz ~ 846.6 MHz LTE Band 4: 1710.7 MHz ~ 1754.3 MHz LTE Band 5: 824.7 MHz ~ 848.3 MHz LTE Band 7: 2502.5 MHz ~ 2567.5 MHz LTE Band 38: 2572.5 MHz ~ 2617.5 MHz WLAN 2.4GHz Band: 2412 MHz ~ 2462 MHz WLAN 5.2GHz Band: 5180 MHz ~ 5240 MHz WLAN 5.3GHz Band: 5260 MHz ~ 5320 MHz WLAN 5.5GHz Band: 5500 MHz ~ 5720 MHz WLAN 5.8GHz Band: 5745 MHz ~ 5805 MHz Bluetooth: 2402 MHz ~ 2480 MHz
Mode	GSM/GPRS/EGPRS RMC/AMR 12.2Kbps HSDPA HSUPA DC-HSDPA HSPA+ (16QAM uplink is not supported) LTE: QPSK, 16QAM, 64QAM WLAN 2.4GHz 802.11b/g/n HT20/HT40 WLAN 5GHz 802.11a/n HT20/HT40 WLAN 5GHz 802.11ac VHT20/VHT40/VHT80 Bluetooth BR/EDR/LE
HW Version	P2.0
SW Version	MIUI 9
GSM / (E)GPRS Transfer mode	Class B – EUT cannot support Packet Switched and Circuit Switched Network simultaneously but can automatically switch between Packet and Circuit Switched Network.
EUT Stage	Identical Prototype

Remark:

1. WLAN operation in 5600 MHz ~ 5650 MHz is notched.
2. This device does not support DTM operation and supports GRPS/EGRPS mode up to multi-slot class 33.
3. This device supports VoIP in GPRS, EGPRS, CDMA, WCDMA and LTE (e.g. for 3rd-party VoIP), LTE supports VoLTE operation.
4. This device 2.4GHz WLAN support hotspot operation and Bluetooth support tethering applications.
5. This device 2.4GHz WLAN/5.2GHz/WLAN5.8GHz support hotspot operation, and WLAN 5.2GHz/5.8GHz WLAN supports WiFi Direct (GC/GO), and 5.3GHz / 5.5GHz supports WiFi Direct (GC only).
6. The device employs proximity sensors and when the sensor detects a user is touching the device on or near to the antenna the device reduces the maximum allowed output power. When detected the presence of the user's body at the front or back or bottom side or top side faces of the device, GSM1900, WCDMA B2 / B4 and LTE B4 / B7 / B38 reduced power will be active. The device also implanted infrared light sensing and when detect a user(for example ,human head) near to the device for front side, It will also trigger power reduction for GSM1900, WCDMA B2 / B4 and LTE B4 / B7 / B38 which the reduced power level are the same as proximity sensors triggered reduced power level. Detailed descriptions of the proximity sensor trigger power reduction mechanism are included in the operational description.
7. This device has two WWAN transmit antennas. WWAN top antenna is located at the top edge of the device, WWAN bottom antenna is located at the bottom edge of the device. More details of the antennas can refer to antenna location chapter. They support the same WWAN bands and they can't transmit simultaneously.



4.2 General LTE SAR Test and Reporting Considerations

Summarized necessary items addressed in KDB 941225 D05 v02r05																																																															
FCC ID	2AFZZ-RMSE7TG																																																														
Equipment Name	Mobile Phone																																																														
Operating Frequency Range of each LTE transmission band	LTE Band 4: 1710.7 MHz ~ 1754.3 MHz LTE Band 5: 824.7 MHz ~ 848.3 MHz LTE Band 7: 2502.5 MHz ~ 2567.5 MHz LTE Band 38: 2572.5 MHz ~ 2617.5 MHz																																																														
Channel Bandwidth	LTE Band 4: 1.4MHz, 3MHz, 5MHz, 10MHz, 15MHz, 20MHz LTE Band 5: 1.4MHz, 3MHz, 5MHz, 10MHz LTE Band 7: 5MHz, 10MHz, 15MHz, 20MHz LTE Band 38: 5MHz, 10MHz, 15MHz, 20MHz																																																														
uplink modulations used	QPSK / 16QAM / 64QAM																																																														
LTE Voice / Data requirements	Voice and Data																																																														
LTE Release Version	R12, Cat12																																																														
CA Support	Yes, Uplink and Downlink																																																														
LTE MPR permanently built-in by design	<p>Table 6.2.3-1: Maximum Power Reduction (MPR) for Power Class 1, 2 and 3</p> <table border="1"> <thead> <tr> <th rowspan="2">Modulation</th> <th colspan="6">Channel bandwidth / Transmission bandwidth (N_{RB})</th> <th rowspan="2">MPR (dB)</th> </tr> <tr> <th>1.4 MHz</th> <th>3.0 MHz</th> <th>5 MHz</th> <th>10 MHz</th> <th>15 MHz</th> <th>20 MHz</th> </tr> </thead> <tbody> <tr> <td>QPSK</td> <td>> 5</td> <td>> 4</td> <td>> 8</td> <td>> 12</td> <td>> 16</td> <td>> 18</td> <td>≤ 1</td> </tr> <tr> <td>16 QAM</td> <td>≤ 5</td> <td>≤ 4</td> <td>≤ 8</td> <td>≤ 12</td> <td>≤ 16</td> <td>≤ 18</td> <td>≤ 1</td> </tr> <tr> <td>16 QAM</td> <td>> 5</td> <td>> 4</td> <td>> 8</td> <td>> 12</td> <td>> 16</td> <td>> 18</td> <td>≤ 2</td> </tr> <tr> <td>64 QAM</td> <td>≤ 5</td> <td>≤ 4</td> <td>≤ 8</td> <td>≤ 12</td> <td>≤ 16</td> <td>≤ 18</td> <td>≤ 2</td> </tr> <tr> <td>64 QAM</td> <td>> 5</td> <td>> 4</td> <td>> 8</td> <td>> 12</td> <td>> 16</td> <td>> 18</td> <td>≤ 3</td> </tr> <tr> <td>256 QAM</td> <td colspan="6" style="text-align: center;">≥ 1</td> <td>≤ 5</td> </tr> </tbody> </table>	Modulation	Channel bandwidth / Transmission bandwidth (N _{RB})						MPR (dB)	1.4 MHz	3.0 MHz	5 MHz	10 MHz	15 MHz	20 MHz	QPSK	> 5	> 4	> 8	> 12	> 16	> 18	≤ 1	16 QAM	≤ 5	≤ 4	≤ 8	≤ 12	≤ 16	≤ 18	≤ 1	16 QAM	> 5	> 4	> 8	> 12	> 16	> 18	≤ 2	64 QAM	≤ 5	≤ 4	≤ 8	≤ 12	≤ 16	≤ 18	≤ 2	64 QAM	> 5	> 4	> 8	> 12	> 16	> 18	≤ 3	256 QAM	≥ 1						≤ 5
Modulation	Channel bandwidth / Transmission bandwidth (N _{RB})						MPR (dB)																																																								
	1.4 MHz	3.0 MHz	5 MHz	10 MHz	15 MHz	20 MHz																																																									
QPSK	> 5	> 4	> 8	> 12	> 16	> 18	≤ 1																																																								
16 QAM	≤ 5	≤ 4	≤ 8	≤ 12	≤ 16	≤ 18	≤ 1																																																								
16 QAM	> 5	> 4	> 8	> 12	> 16	> 18	≤ 2																																																								
64 QAM	≤ 5	≤ 4	≤ 8	≤ 12	≤ 16	≤ 18	≤ 2																																																								
64 QAM	> 5	> 4	> 8	> 12	> 16	> 18	≤ 3																																																								
256 QAM	≥ 1						≤ 5																																																								
LTE A-MPR	In the base station simulator configuration, Network Setting value is set to NS_01 to disable A-MPR during SAR testing and the LTE SAR tests was transmitting on all TTI frames (Maximum TTI)																																																														
Spectrum plots for RB configuration	A properly configured base station simulator was used for the SAR and power measurement; therefore, spectrum plots for each RB allocation and offset configuration are not included in the SAR report.																																																														
Power reduction applied to satisfy SAR compliance	Yes The device employs proximity sensors that detect the presence of the user's body at the front or back or top or bottom side faces of the device. When front or back or top side or bottom side condition is detected, LTE B4 / B7 / B38 reduced power will be active.																																																														
LTE Carrier Aggregation Combinations	Intra-Band possible combinations and the detail power verification please referred to section 13.																																																														
LTE Carrier Aggregation Additional Information	(1) This device supports LTE Carrier Aggregation (CA) in the downlink and uplink for LTE B7 / B38 with two component carriers in the downlink and uplink. SAR Measurements and conducted powers were evaluated per FCC Guidance. (2) Additional following LTE Release features are not supported: Relay, HetNet, Enhanced MIMO, eICI, WiFi Offloading, MDH, eMBMA, Cross-Carrier Scheduling, Enhanced SC-FDMA.																																																														



Transmission (H, M, L) channel numbers and frequencies in each LTE band												
LTE Band 4												
	Bandwidth 1.4 MHz		Bandwidth 3 MHz		Bandwidth 5 MHz		Bandwidth 10 MHz		Bandwidth 15 MHz		Bandwidth 20 MHz	
	Ch. #	Freq. (MHz)	Ch. #	Freq. (MHz)	Ch. #	Freq. (MHz)	Ch. #	Freq. (MHz)	Ch. #	Freq. (MHz)	Ch. #	Freq. (MHz)
L	19957	1710.7	19965	1711.5	19975	1712.5	20000	1715	20025	1717.5	20050	1720
M	20175	1732.5	20175	1732.5	20175	1732.5	20175	1732.5	20175	1732.5	20175	1732.5
H	20393	1754.3	20385	1753.5	20375	1752.5	20350	1750	20325	1747.5	20300	1745
LTE Band 5												
	Bandwidth 1.4 MHz		Bandwidth 3 MHz		Bandwidth 5 MHz		Bandwidth 10 MHz					
	Ch. #	Freq. (MHz)	Ch. #	Freq. (MHz)	Ch. #	Freq. (MHz)	Ch. #	Freq. (MHz)	Ch. #	Freq. (MHz)		
L	20407	824.7	20415	825.5	20425	826.5	20450	829				
M	20525	836.5	20525	836.5	20525	836.5	20525	836.5				
H	20643	848.3	20635	847.5	20625	846.5	20600	844				
LTE Band 7												
	Bandwidth 5 MHz		Bandwidth 10 MHz		Bandwidth 15 MHz		Bandwidth 20 MHz					
	Ch. #	Freq. (MHz)	Ch. #	Freq. (MHz)	Ch. #	Freq. (MHz)	Ch. #	Freq. (MHz)	Ch. #	Freq. (MHz)		
L	20775	2502.5	20800	2505	20825	2507.5	20850	2510				
M	21100	2535	21100	2535	21100	2535	21100	2535				
H	21425	2567.5	21400	2565	21375	2562.5	21350	2560				
LTE Band 38												
	Bandwidth 5 MHz		Bandwidth 10 MHz		Bandwidth 15 MHz		Bandwidth 20 MHz					
	Ch. #	Freq. (MHz)	Ch. #	Freq. (MHz)	Ch. #	Freq. (MHz)	Ch. #	Freq. (MHz)	Ch. #	Freq. (MHz)		
L	37775	2572.5	37800	2575	37825	2577.5	37850	2580				
M	38000	2595	38000	2595	38000	2595	38000	2595				
H	38225	2617.5	38200	2615	38175	2612.5	38150	2610				

5. Proximity Sensor Triggering Test

5.1 Proximity sensor triggering distances(Per KDB616217§6.2)

1. Proximity sensor triggering distance testing was performed according to the procedures outlined in KDB 616217 D04 section 6.2, and EUT moving further away from the flat phantom and EUT moving toward the flat phantom were both assessed and the tissue-equivalent medium for highest frequency (2600MHz) and lowest (1750MHz) frequency was used for proximity sensor triggering testing.
2. Capacitive proximity sensor placed coincident with antenna elements at the top and bottom end of the phone are utilized to determine when the device comes in proximity of the user's body at the front, back, top side or bottom side surface of the device. There is no need to do sensor coverage testing for the proximity sensor is designed to support sufficient detection range and sensitivity to cover regions of the sensors in all applicable directions since the proximity sensor entirely covers the antenna.
3. The device also implanted infrared light sensing and when detect a user(for example ,human head) near to the device for front side, It will also trigger power reduction.
4. When Proximity sensor or infrared light sensing is active, GSM1900, WCDMA B2 / B4 and LTE B4 / B7 / B38 reduced power will be active. The reduced power levels are the same.
5. The sensors used to detect the proximity of the user's body at the front, back, top side or bottom side surface of the device use a detection threshold distance. The data shown in the sections below shows the distance(s).

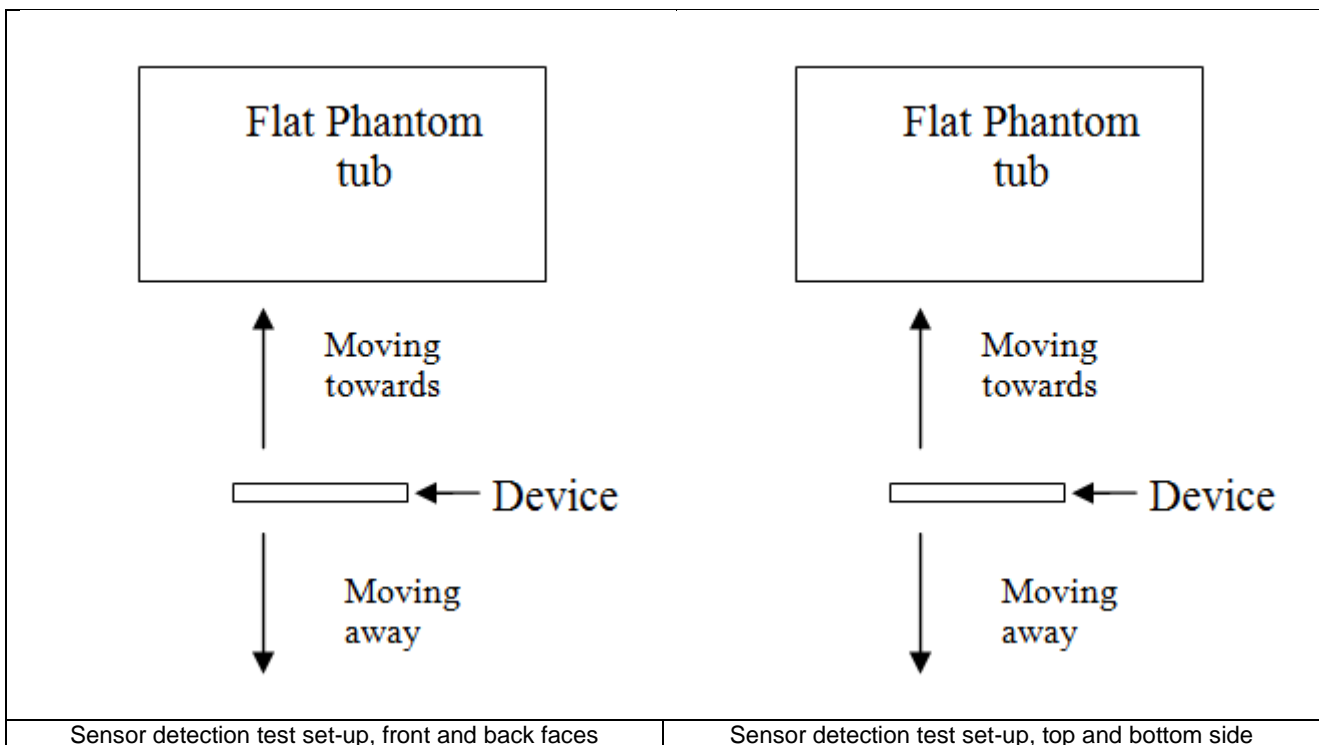

Top Antenna SAR Sensor Pad

Proximity Sensor Triggering Distance (mm)						
Position	Front		Back		Top Side	
	Moving towards	Moving away	Moving towards	Moving away	Moving towards	Moving away
Minimum	15	17	21	22	18	20

Bottom Antenna SAR Sensor Pad

Proximity Sensor Triggering Distance (mm)						
Position	Front		Back		Bottom Side	
	Moving towards	Moving away	Moving towards	Moving away	Moving towards	Moving away
Minimum	15	17	20	22	22	23

Infrared light Sensor

Infrared Light Sensor Triggering Distance (mm)		
Position	Front	
	Moving towards	Moving away
Minimum	41	46

<Sensor Trigger Distance for Top Antenna Sensor Pad>

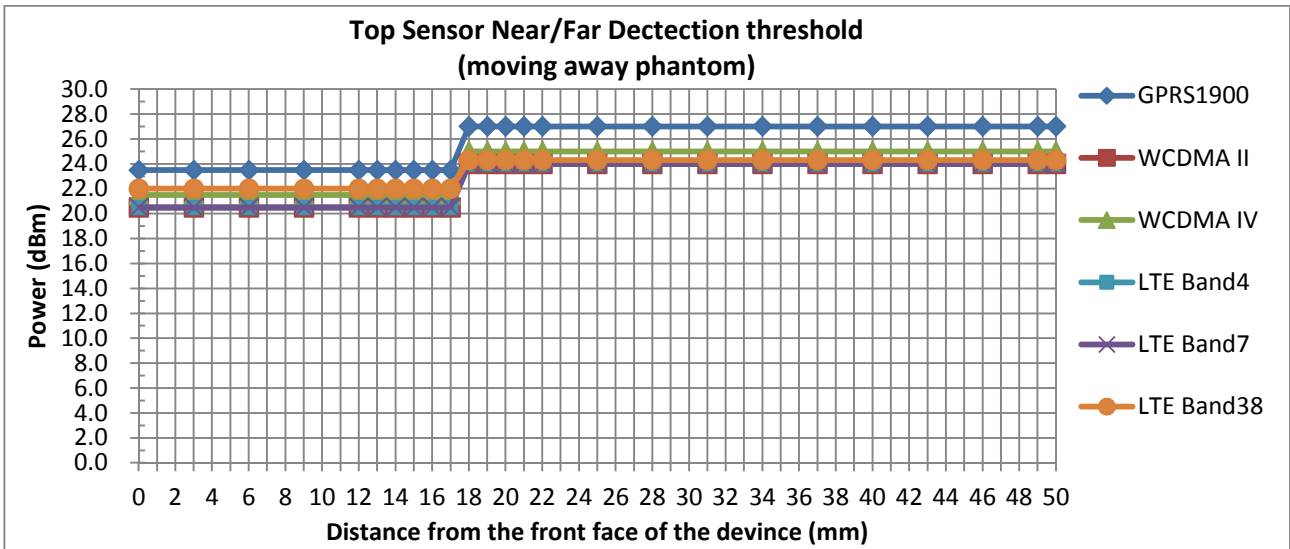
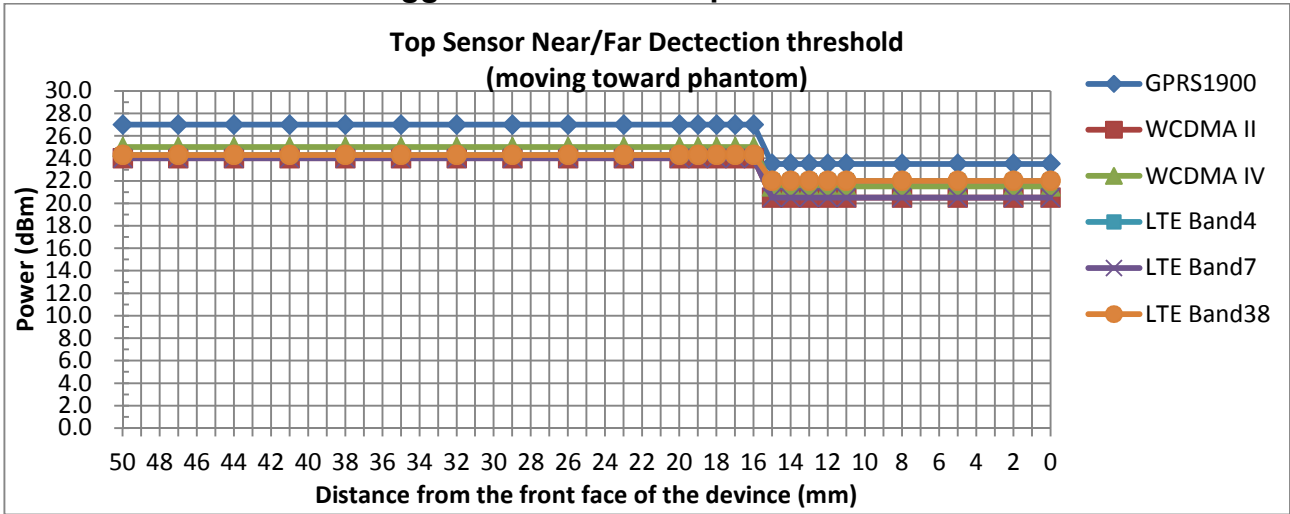

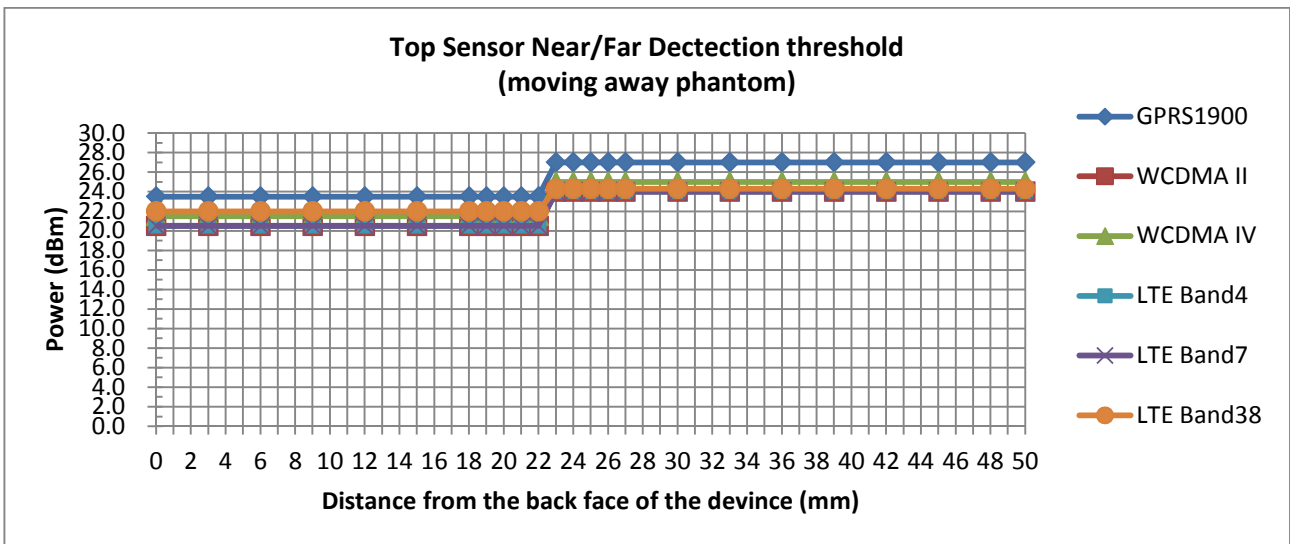
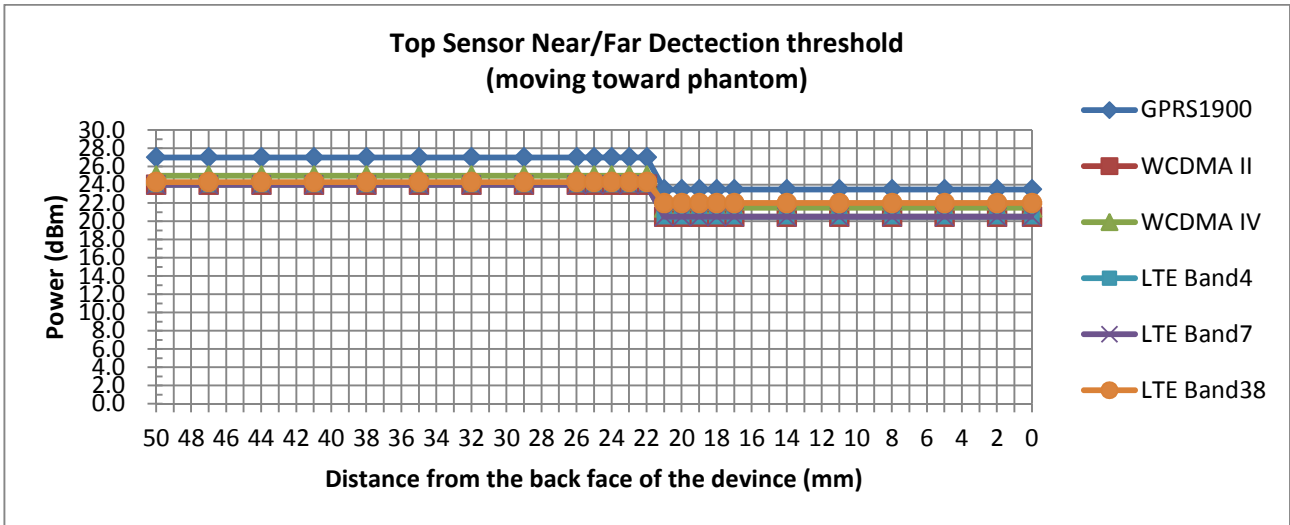

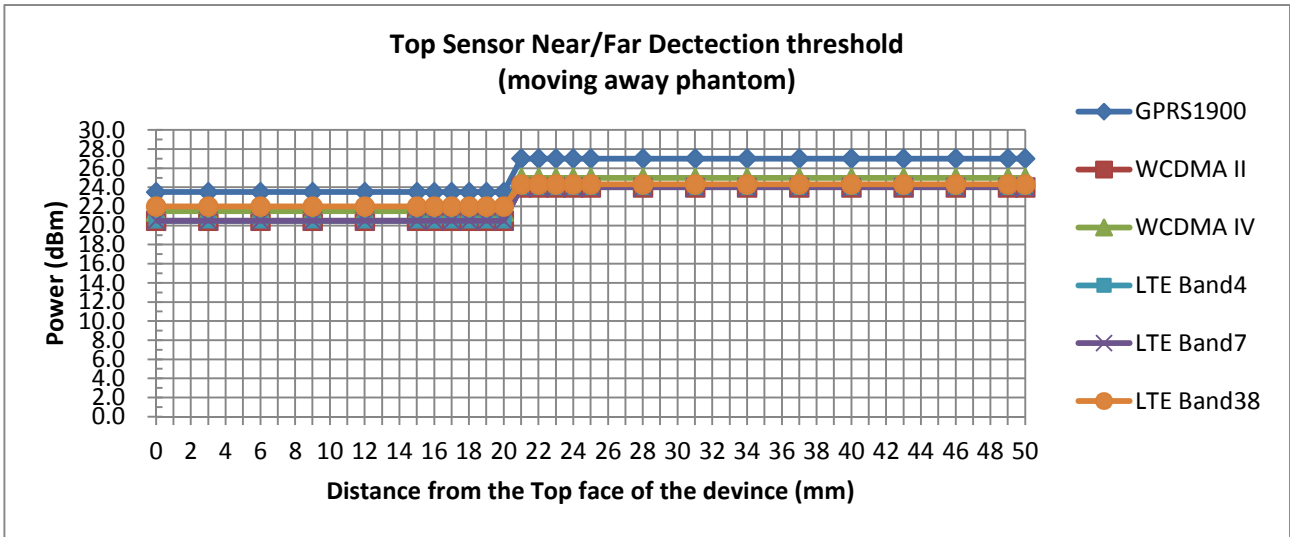
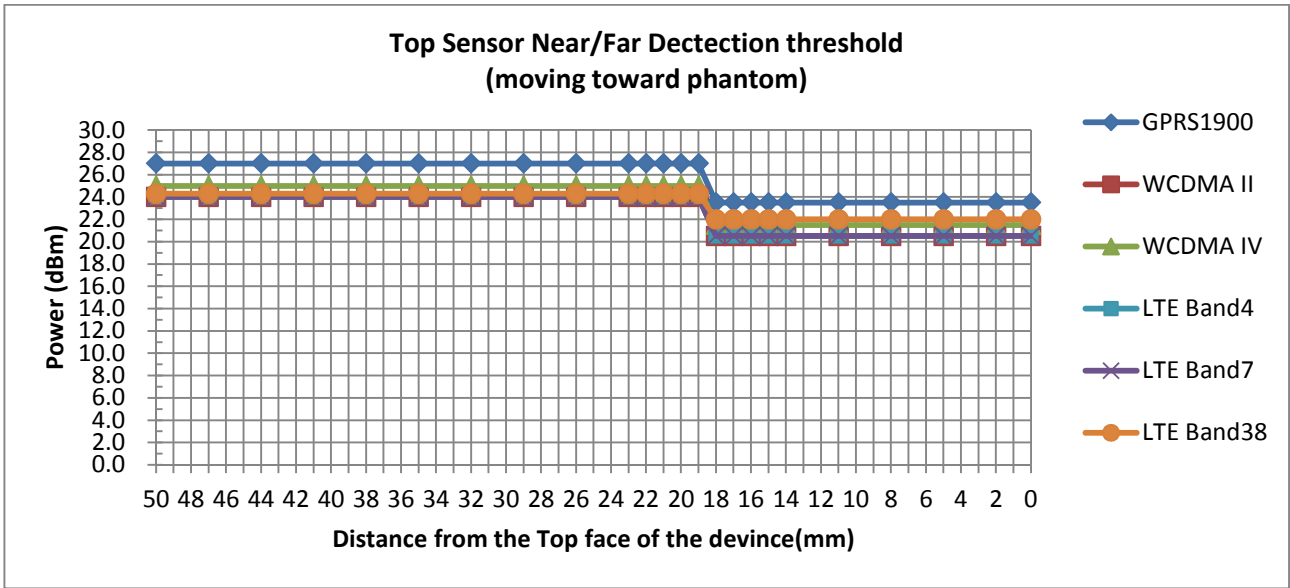

<Sensor Trigger Distance for Bottom Antenna Sensor Pad>

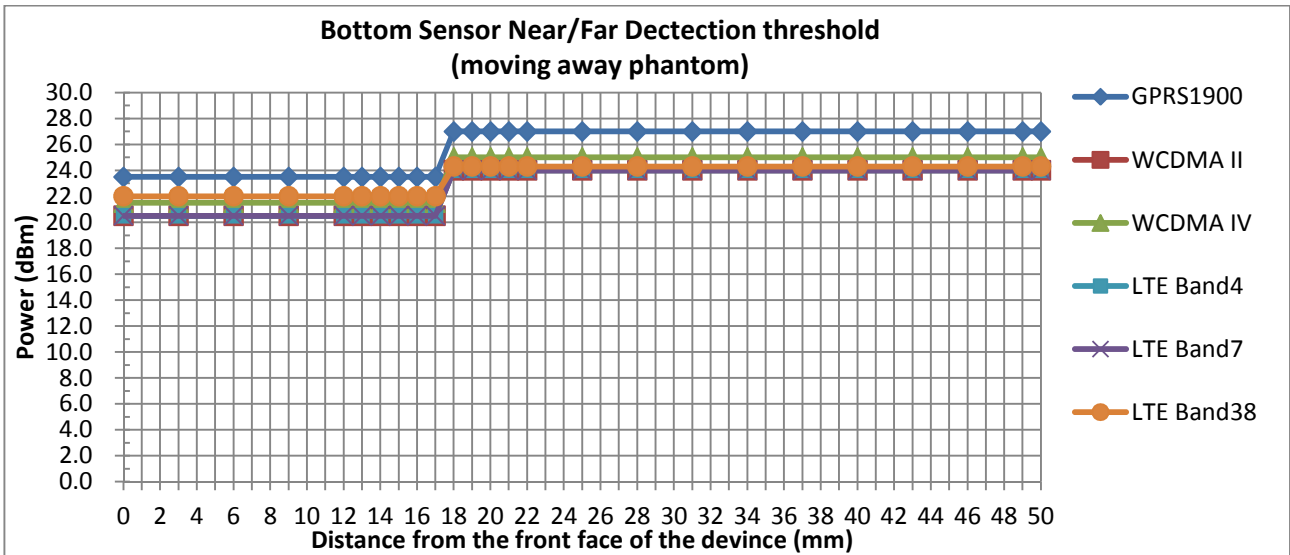
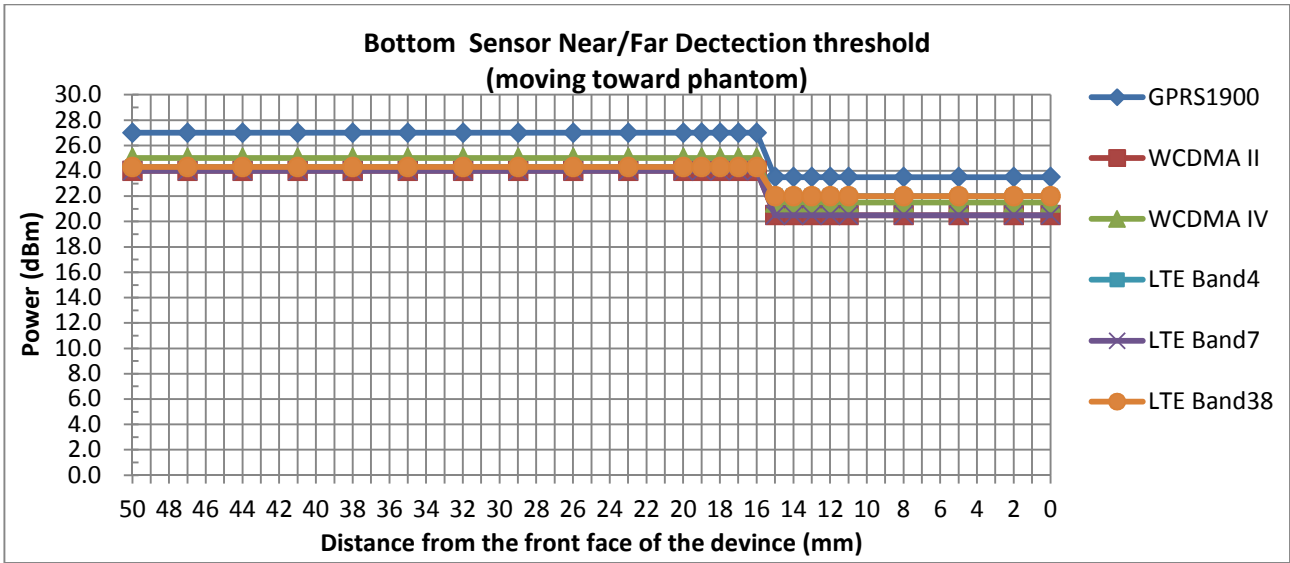

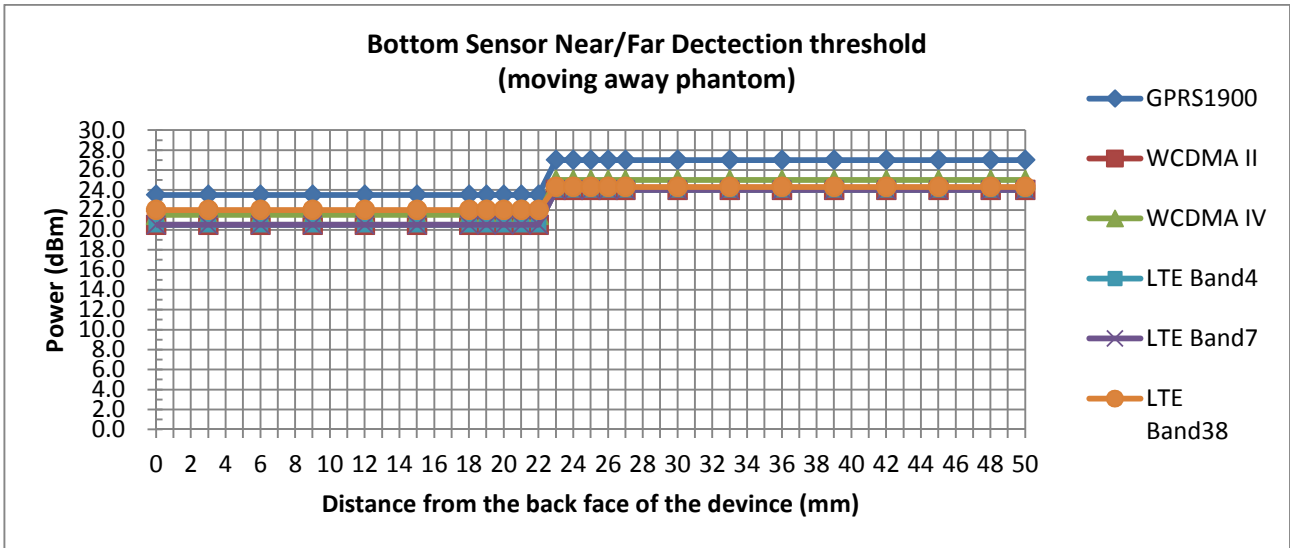
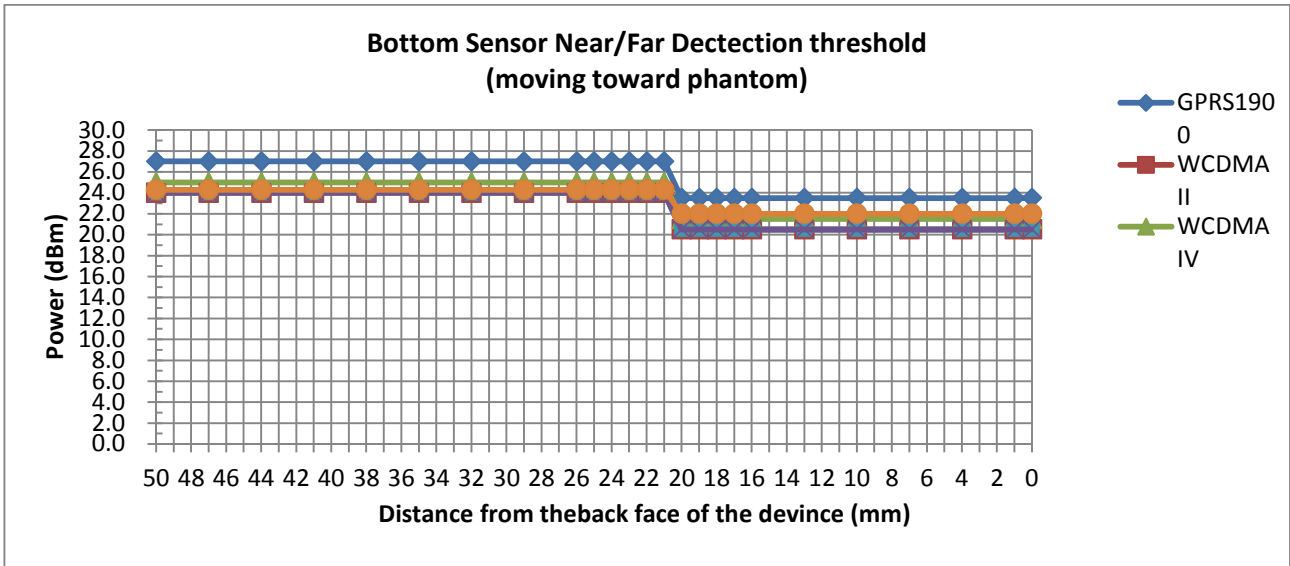

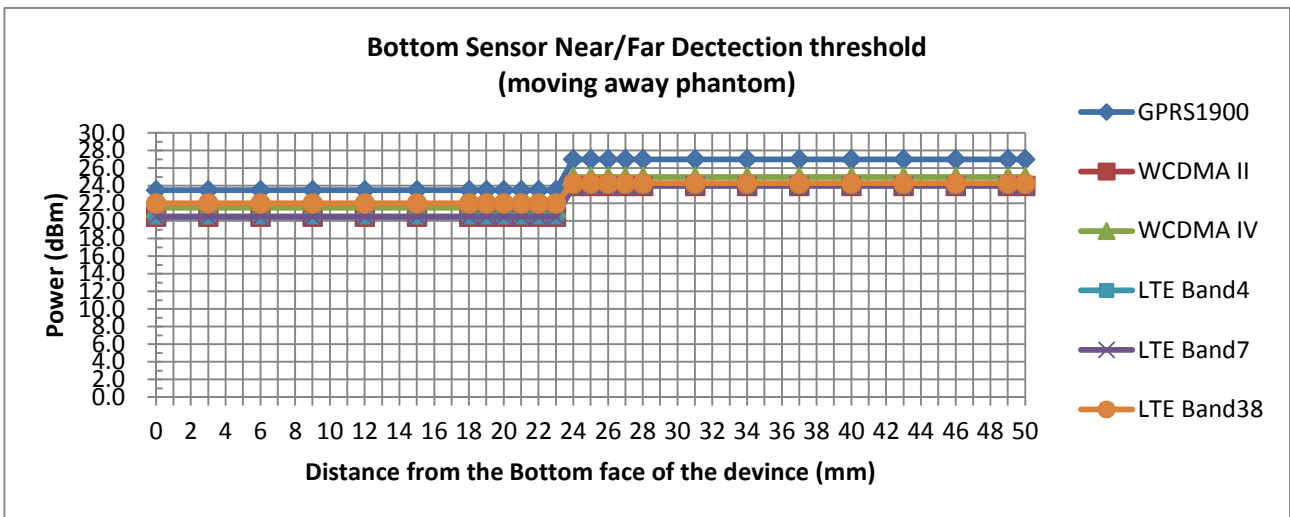
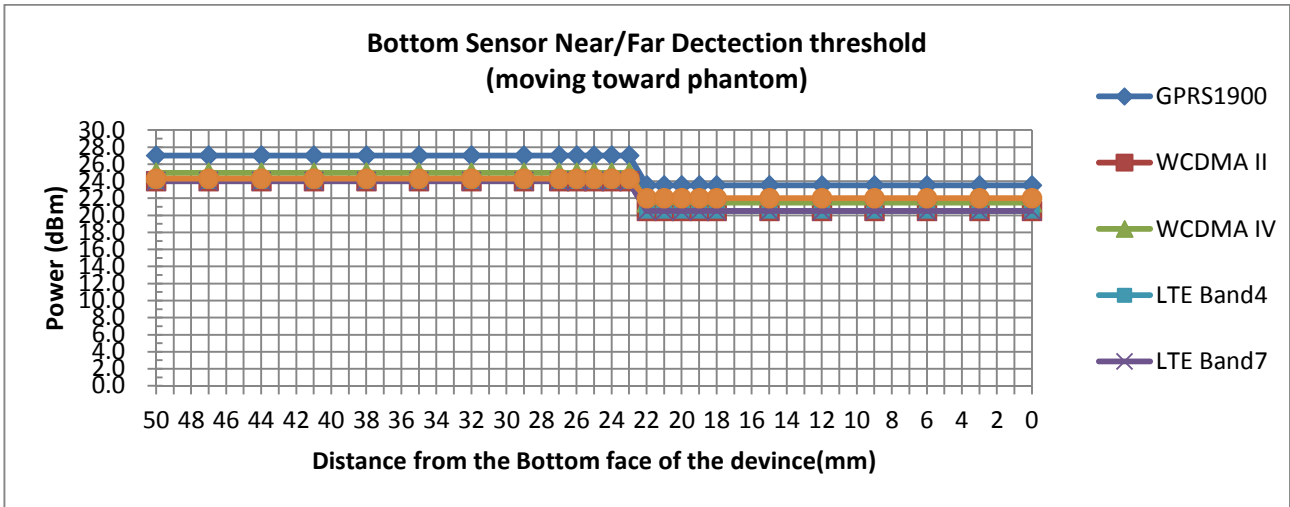

<Sensor Trigger Distance for Infrared Light Sensor>

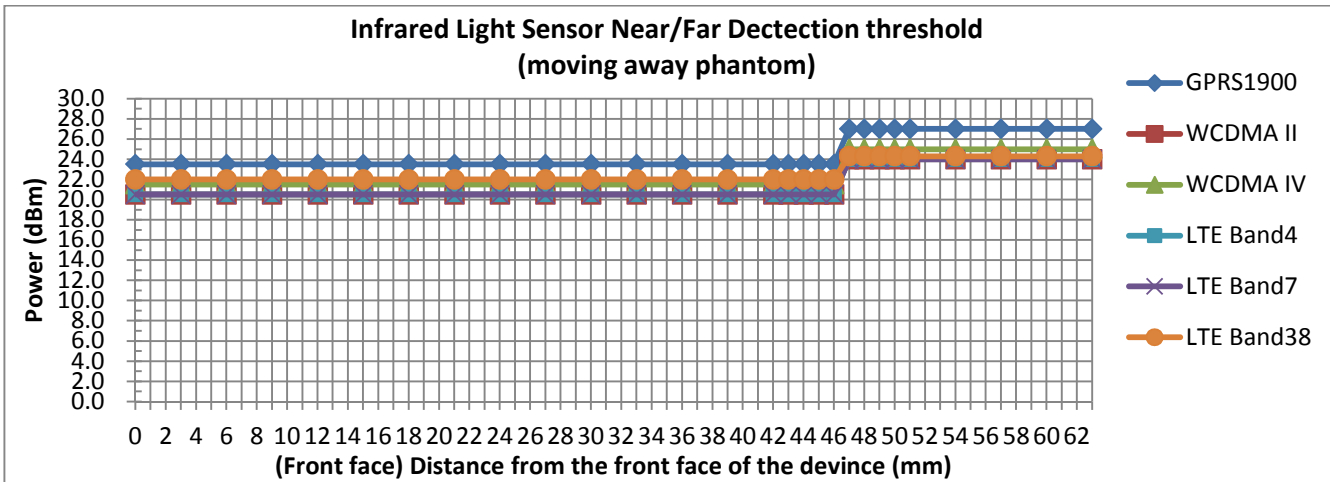
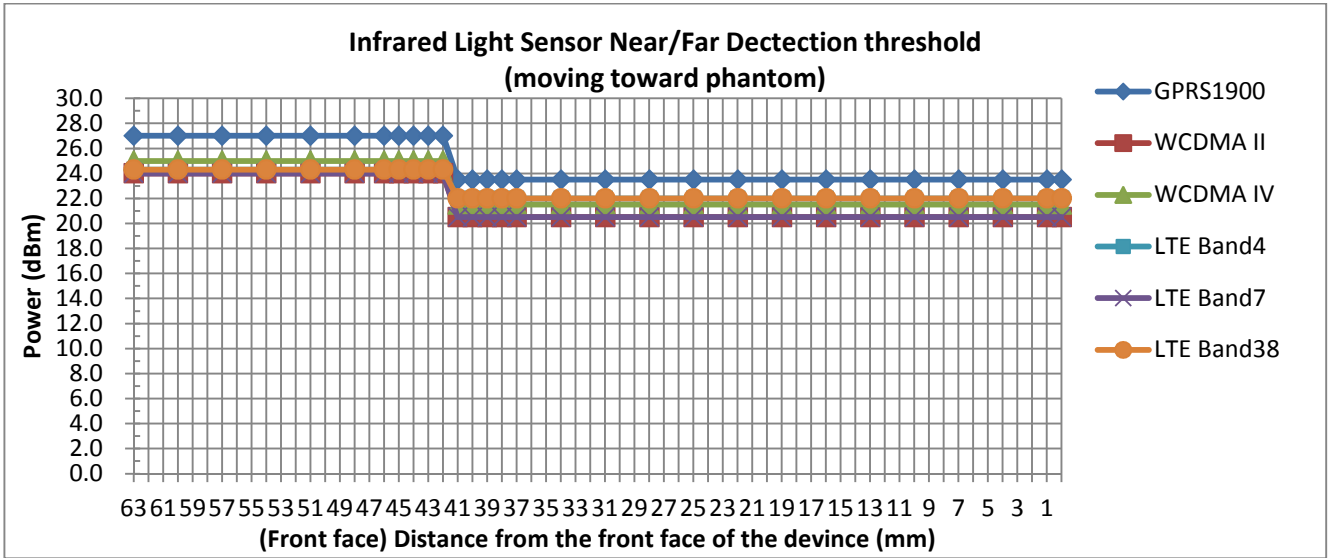

6. RF Exposure Limits

6.1 Uncontrolled Environment

Uncontrolled Environments are defined as locations where there is the exposure of individuals who have no knowledge or control of their exposure. The general population/uncontrolled exposure limits are applicable to situations in which the general public may be exposed or in which persons who are exposed as a consequence of their employment may not be made fully aware of the potential for exposure or cannot exercise control over their exposure. Members of the general public would come under this category when exposure is not employment-related; for example, in the case of a wireless transmitter that exposes persons in its vicinity.

6.2 Controlled Environment

Controlled Environments are defined as locations where there is exposure that may be incurred by persons who are aware of the potential for exposure, (i.e. as a result of employment or occupation). In general, occupational/controlled exposure limits are applicable to situations in which persons are exposed as a consequence of their employment, who have been made fully aware of the potential for exposure and can exercise control over their exposure. The exposure category is also applicable when the exposure is of a transient nature due to incidental passage through a location where the exposure levels may be higher than the general population/uncontrolled limits, but the exposed person is fully aware of the potential for exposure and can exercise control over his or her exposure by leaving the area or by some other appropriate means.

Limits for Occupational/Controlled Exposure (W/kg)

Whole-Body	Partial-Body	Hands, Wrists, Feet and Ankles
0.4	8.0	20.0

Limits for General Population/Uncontrolled Exposure (W/kg)

Whole-Body	Partial-Body	Hands, Wrists, Feet and Ankles
0.08	1.6	4.0

Whole-Body SAR is averaged over the entire body, partial-body SAR is averaged over any 1gram of tissue defined as a tissue volume in the shape of a cube. SAR for hands, wrists, feet and ankles is averaged over any 10 grams of tissue defined as a tissue volume in the shape of a cube.

7. Specific Absorption Rate (SAR)

7.1 Introduction

SAR is related to the rate at which energy is absorbed per unit mass in an object exposed to a radio field. The SAR distribution in a biological body is complicated and is usually carried out by experimental techniques or numerical modeling. The standard recommends limits for two tiers of groups, occupational/controlled and general population/uncontrolled, based on a person's awareness and ability to exercise control over his or her exposure. In general, occupational/controlled exposure limits are higher than the limits for general population/uncontrolled.

7.2 SAR Definition

The SAR definition is the time derivative (rate) of the incremental energy (dW) absorbed by (dissipated in) an incremental mass (dm) contained in a volume element (dv) of a given density (ρ). The equation description is as below:

$$\text{SAR} = \frac{d}{dt} \left(\frac{dW}{dm} \right) = \frac{d}{dt} \left(\frac{dW}{\rho dv} \right)$$

SAR is expressed in units of Watts per kilogram (W/kg)

$$\text{SAR} = \frac{\sigma |E|^2}{\rho}$$

Where: σ is the conductivity of the tissue, ρ is the mass density of the tissue and E is the RMS electrical field strength.

8. System Description and Setup

The DASY system used for performing compliance tests consists of the following items:

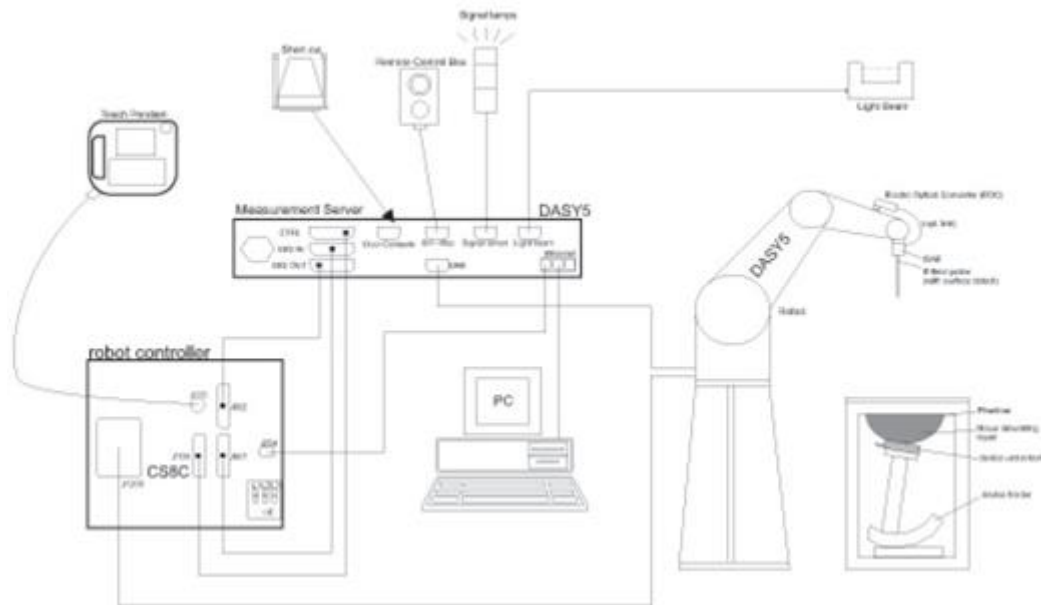

- A standard high precision 6-axis robot with controller, teach pendant and software. An arm extension for accommodating the data acquisition electronics (DAE).
- An isotropic Field probe optimized and calibrated for the targeted measurement.
- A data acquisition electronics (DAE) which performs the signal amplification, signal multiplexing, AD-conversion, offset measurements, mechanical surface detection, collision detection, etc. The unit is battery powered with standard or rechargeable batteries. The signal is optically transmitted to the EOC.
- The Electro-optical converter (EOC) performs the conversion from optical to electrical signals for the digital communication to the DAE. To use optical surface detection, a special version of the EOC is required. The EOC signal is transmitted to the measurement server.
- The function of the measurement server is to perform the time critical tasks such as signal filtering, control of the robot operation and fast movement interrupts.
- The Light Beam used is for probe alignment. This improves the (absolute) accuracy of the probe positioning.
- A computer running WinXP or Win7 and the DASY5 software.
- Remote control and teach pendant as well as additional circuitry for robot safety such as warning lamps, etc.
- The phantom, the device holder and other accessories according to the targeted measurement.

8.1 E-Field Probe

The SAR measurement is conducted with the dosimetric probe (manufactured by SPEAG).The probe is specially designed and calibrated for use in liquid with high permittivity. The dosimetric probe has special calibration in liquid at different frequency. This probe has a built in optical surface detection system to prevent from collision with phantom.

<EX3DV4 Probe>

Construction	Symmetric design with triangular core Built-in shielding against static charges PEEK enclosure material (resistant to organic solvents, e.g., DGBE)	
Frequency	10 MHz – >6 GHz Linearity: ±0.2 dB (30 MHz – 6 GHz)	
Directivity	±0.3 dB in TSL (rotation around probe axis) ±0.5 dB in TSL (rotation normal to probe axis)	
Dynamic Range	10 µW/g – >100 mW/g Linearity: ±0.2 dB (noise: typically <1 µW/g)	
Dimensions	Overall length: 337 mm (tip: 20 mm) Tip diameter: 2.5 mm (body: 12 mm) Typical distance from probe tip to dipole centers: 1 mm	

8.2 Data Acquisition Electronics (DAE)

The data acquisition electronics (DAE) consists of a highly sensitive electrometer-grade preamplifier with auto-zeroing, a channel and gain-switching multiplexer, a fast 16 bit AD-converter and a command decoder and control logic unit. Transmission to the measurement server is accomplished through an optical downlink for data and status information as well as an optical uplink for commands and the clock.

The input impedance of the DAE is 200 MOhm; the inputs are symmetrical and floating. Common mode rejection is above 80 dB.



Photo of DAE

8.3 Phantom

<SAM Twin Phantom>

Shell Thickness	2 ± 0.2 mm; Center ear point: 6 ± 0.2 mm
Filling Volume	Approx. 25 liters
Dimensions	Length: 1000 mm; Width: 500 mm; Height: adjustable feet
Measurement Areas	Left Hand, Right Hand, Flat Phantom



The bottom plate contains three pair of bolts for locking the device holder. The device holder positions are adjusted to the standard measurement positions in the three sections. A white cover is provided to tap the phantom during off-periods to prevent water evaporation and changes in the liquid parameters. On the phantom top, three reference markers are provided to identify the phantom position with respect to the robot.

<ELI Phantom>

Shell Thickness	2 ± 0.2 mm (sagging: <1%)
Filling Volume	Approx. 30 liters
Dimensions	Major ellipse axis: 600 mm Minor axis: 400 mm



The ELI phantom is intended for compliance testing of handheld and body-mounted wireless devices in the frequency range of 30 MHz to 6 GHz. ELI4 is fully compatible with standard and all known tissue simulating liquids.

8.4 Device Holder

<Mounting Device for Hand-Held Transmitter>

In combination with the Twin SAM V5.0/V5.0c or ELI phantoms, the Mounting Device for Hand-Held Transmitters enables rotation of the mounted transmitter device to specified spherical coordinates. At the heads, the rotation axis is at the ear opening. Transmitter devices can be easily and accurately positioned according to IEC 62209-1, IEEE 1528, FCC, or other specifications. The device holder can be locked for positioning at different phantom sections (left head, right head, flat). And upgrade kit to Mounting Device to enable easy mounting of wider devices like big smart-phones, e-books, small tablets, etc. It holds devices with width up to 140 mm.



Mounting Device for Hand-Held Transmitters



Mounting Device Adaptor for Wide-Phones

<Mounting Device for Laptops and other Body-Worn Transmitters>

The extension is lightweight and made of POM, acrylic glass and foam. It fits easily on the upper part of the mounting device in place of the phone positioned. The extension is fully compatible with the SAM Twin and ELI phantoms.



Mounting Device for Laptops

9. Measurement Procedures

The measurement procedures are as follows:

<Conducted power measurement>

- (a) For WWAN power measurement, use base station simulator to configure EUT WWAN transmission in conducted connection with RF cable, at maximum power in each supported wireless interface and frequency band.
- (b) Read the WWAN RF power level from the base station simulator.
- (c) For WLAN/BT power measurement, use engineering software to configure EUT WLAN/BT continuously transmission, at maximum RF power in each supported wireless interface and frequency band
- (d) Connect EUT RF port through RF cable to the power meter, and measure WLAN/BT output power

<SAR measurement>

- (a) Use base station simulator to configure EUT WWAN transmission in radiated connection, and engineering software to configure EUT WLAN/BT continuously transmission, at maximum RF power, in the highest power channel.
- (b) Place the EUT in the positions as Appendix D demonstrates.
- (c) Set scan area, grid size and other setting on the DASY software.
- (d) Measure SAR results for the highest power channel on each testing position.
- (e) Find out the largest SAR result on these testing positions of each band
- (f) Measure SAR results for other channels in worst SAR testing position if the reported SAR of highest power channel is larger than 0.8 W/kg

According to the test standard, the recommended procedure for assessing the peak spatial-average SAR value consists of the following steps:

- (a) Power reference measurement
- (b) Area scan
- (c) Zoom scan
- (d) Power drift measurement

9.1 Spatial Peak SAR Evaluation

The procedure for spatial peak SAR evaluation has been implemented according to the test standard. It can be conducted for 1g and 10g, as well as for user-specific masses. The DASY software includes all numerical procedures necessary to evaluate the spatial peak SAR value.

The base for the evaluation is a "cube" measurement. The measured volume must include the 1g and 10g cubes with the highest averaged SAR values. For that purpose, the center of the measured volume is aligned to the interpolated peak SAR value of a previously performed area scan.

The entire evaluation of the spatial peak values is performed within the post-processing engine (SEMCAD). The system always gives the maximum values for the 1g and 10g cubes. The algorithm to find the cube with highest averaged SAR is divided into the following stages:

- (a) Extraction of the measured data (grid and values) from the Zoom Scan
- (b) Calculation of the SAR value at every measurement point based on all stored data (A/D values and measurement parameters)
- (c) Generation of a high-resolution mesh within the measured volume
- (d) Interpolation of all measured values from the measurement grid to the high-resolution grid
- (e) Extrapolation of the entire 3-D field distribution to the phantom surface over the distance from sensor to surface
- (f) Calculation of the averaged SAR within masses of 1g and 10g

9.2 Power Reference Measurement

The Power Reference Measurement and Power Drift Measurements are for monitoring the power drift of the device under test in the batch process. The minimum distance of probe sensors to surface determines the closest measurement point to phantom surface. This distance cannot be smaller than the distance of sensor calibration points to probe tip as defined in the probe properties.

9.3 Area Scan

The area scan is used as a fast scan in two dimensions to find the area of high field values, before doing a fine measurement around the hot spot. The sophisticated interpolation routines implemented in DASY software can find the maximum found in the scanned area, within a range of the global maximum. The range (in dB0 is specified in the standards for compliance testing. For example, a 2 dB range is required in IEEE standard 1528 and IEC 62209 standards, whereby 3 dB is a requirement when compliance is assessed in accordance with the ARIB standard (Japan), if only one zoom scan follows the area scan, then only the absolute maximum will be taken as reference. For cases where multiple maximums are detected, the number of zoom scans has to be increased accordingly.

Area scan parameters extracted from FCC KDB 865664 D01v01r04 SAR measurement 100 MHz to 6 GHz.

	≤ 3 GHz	> 3 GHz
Maximum distance from closest measurement point (geometric center of probe sensors) to phantom surface	5 ± 1 mm	$\frac{1}{2} \cdot \delta \cdot \ln(2) \pm 0.5$ mm
Maximum probe angle from probe axis to phantom surface normal at the measurement location	30° ± 1°	20° ± 1°
Maximum area scan spatial resolution: Δx_{Area} , Δy_{Area}	≤ 2 GHz: ≤ 15 mm 2 – 3 GHz: ≤ 12 mm	3 – 4 GHz: ≤ 12 mm 4 – 6 GHz: ≤ 10 mm
	When the x or y dimension of the test device, in the measurement plane orientation, is smaller than the above, the measurement resolution must be ≤ the corresponding x or y dimension of the test device with at least one measurement point on the test device.	

9.4 Zoom Scan

Zoom scans are used assess the peak spatial SAR values within a cubic averaging volume containing 1 gram and 10 gram of simulated tissue. The zoom scan measures points (refer to table below) within a cube shoes base faces are centered on the maxima found in a preceding area scan job within the same procedure. When the measurement is done, the zoom scan evaluates the averaged SAR for 1 gram and 10 gram and displays these values next to the job's label.

Zoom scan parameters extracted from FCC KDB 865664 D01v01r04 SAR measurement 100 MHz to 6 GHz.

		≤ 3 GHz	> 3 GHz	
Maximum zoom scan spatial resolution: $\Delta x_{Zoom}, \Delta y_{Zoom}$		≤ 2 GHz: ≤ 8 mm 2 – 3 GHz: ≤ 5 mm*	3 – 4 GHz: ≤ 5 mm* 4 – 6 GHz: ≤ 4 mm*	
Maximum zoom scan spatial resolution, normal to phantom surface	uniform grid: $\Delta z_{Zoom}(n)$	≤ 5 mm	3 – 4 GHz: ≤ 4 mm 4 – 5 GHz: ≤ 3 mm 5 – 6 GHz: ≤ 2 mm	
	graded grid	$\Delta z_{Zoom}(1)$: between 1 st two points closest to phantom surface	≤ 4 mm	3 – 4 GHz: ≤ 3 mm 4 – 5 GHz: ≤ 2.5 mm 5 – 6 GHz: ≤ 2 mm
		$\Delta z_{Zoom}(n>1)$: between subsequent points	$\leq 1.5 \cdot \Delta z_{Zoom}(n-1)$	
Minimum zoom scan volume	x, y, z	≥ 30 mm	3 – 4 GHz: ≥ 28 mm 4 – 5 GHz: ≥ 25 mm 5 – 6 GHz: ≥ 22 mm	
Note: δ is the penetration depth of a plane-wave at normal incidence to the tissue medium; see draft standard IEEE P1528-2011 for details. * When zoom scan is required and the <i>reported</i> SAR from the <i>area scan based 1-g SAR estimation</i> procedures of KDB 447498 is ≤ 1.4 W/kg, ≤ 8 mm, ≤ 7 mm and ≤ 5 mm zoom scan resolution may be applied, respectively, for 2 GHz to 3 GHz, 3 GHz to 4 GHz and 4 GHz to 6 GHz.				

9.5 Volume Scan Procedures

The volume scan is used for assess overlapping SAR distributions for antennas transmitting in different frequency bands. It is equivalent to an oversized zoom scan used in standalone measurements. The measurement volume will be used to enclose all the simultaneous transmitting antennas. For antennas transmitting simultaneously in different frequency bands, the volume scan is measured separately in each frequency band. In order to sum correctly to compute the 1g aggregate SAR, the EUT remain in the same test position for all measurements and all volume scan use the same spatial resolution and grid spacing. When all volume scan were completed, the software, SEMCAD postprocessor can combine and subsequently superpose these measurement data to calculating the multiband SAR.

9.6 Power Drift Monitoring

All SAR testing is under the EUT install full charged battery and transmit maximum output power. In DASy measurement software, the power reference measurement and power drift measurement procedures are used for monitoring the power drift of EUT during SAR test. Both these procedures measure the field at a specified reference position before and after the SAR testing. The software will calculate the field difference in dB. If the power drifts more than 5%, the SAR will be retested.



10. Test Equipment List

Manufacturer	Name of Equipment	Type/Model	Serial Number	Calibration	
				Last Cal.	Due Date
SPEAG	835MHz System Validation Kit	D835V2	4d091	2017/12/5	2018/12/4
SPEAG	1750MHz System Validation Kit	D1750V2	1069	2017/12/5	2018/12/4
SPEAG	1900MHz System Validation Kit	D1900V2	5d118	2017/12/6	2018/12/5
SPEAG	2450MHz System Validation Kit	D2450V2	840	2017/12/7	2018/12/6
SPEAG	2600MHz System Validation Kit	D2600V2	1061	2017/12/7	2018/12/6
SPEAG	5000MHz System Validation Kit	D5GHzV2	1006	2017/9/26	2018/9/25
SPEAG	Data Acquisition Electronics	DAE4	1210	2018/5/28	2019/5/27
SPEAG	Dosimetric E-Field Probe	EX3DV4	3857	2018/5/31	2019/5/30
SPEAG	SAM Twin Phantom	QD 000 P40 CB	TP-1164	NCR	NCR
SPEAG	SAM Twin Phantom	QD 000 P40 CB	TP-1644	NCR	NCR
SPEAG	SAM Twin Phantom	QD 000 P40 CB	TP-1542	NCR	NCR
SPEAG	Phone Positioner	N/A	N/A	NCR	NCR
Anritsu	Radio communication analyzer	MT8820C	6201563814	2018/1/18	2019/1/17
Agilent	Wireless Communication Test Set	E5515C	MY52102706	2018/4/17	2019/4/16
Agilent	ENA Series Network Analyzer	E5071C	MY46111157	2018/4/17	2019/4/16
SPEAG	DAK Kit	DAK3.5	1146	2017/7/18	2018/7/17
R&S	Signal Generator	SML03	103818	2017/8/17	2018/8/16
Anritsu	Power Meter	ML2495A	1419002	2018/5/14	2019/5/13
Anritsu	Power Sensor	MA2411B	1339124	2018/5/14	2019/5/13
Anritsu	Power Meter	ML2495A	1218006	2017/10/6	2018/10/5
Anritsu	Power Sensor	MA2411B	1207363	2017/10/6	2018/10/5
R&S	CBT BLUETOOTH TESTER	CBT	100783	2017/8/8	2018/8/7
EXA	Spectrum Analyzer	FSV7	101742	2018/1/19	2019/1/18
Testo	Hygrometer	608-H1	1241332096	2017/8/21	2018/8/20
FLUKE	DIGITAC THERMOMETER	51II	97240029	2017/8/3	2018/8/2
ARRA	Power Divider	A3200-2	N/A		Note
Agilent	Dual Directional Coupler	778D	50422		Note
PASTERNAK	Dual Directional Coupler	PE2214-10	N/A		Note
MCL	Attenuation1	BW-S10W5+	N/A		Note
MCL	Attenuation2	BW-S10W5+	N/A		Note
MCL	Attenuation3	BW-S10W5+	N/A		Note
AR	Amplifier	5S1G4	333096		Note
mini-circuits	Amplifier	ZVE-3W-83+	162601250		Note

Note:

Prior to system verification and validation, the path loss from the signal generator to the system check source and the power meter, which includes the amplifier, cable, attenuator and directional coupler, was measured by the network analyzer. The reading of the power meter was offset by the path loss difference between the path to the power meter and the path to the system check source to monitor the actual power level fed to the system check source.

11. System Verification

11.1 Tissue Simulating Liquids

For the measurement of the field distribution inside the SAM phantom with DASY, the phantom must be filled with around 25 liters of homogeneous body tissue simulating liquid. For head SAR testing, the liquid height from the ear reference point (ERP) of the phantom to the liquid top surface is larger than 15 cm, which is shown in Fig. 10.1. For body SAR testing, the liquid height from the center of the flat phantom to the liquid top surface is larger than 15 cm, which is shown in Fig. 10.2.

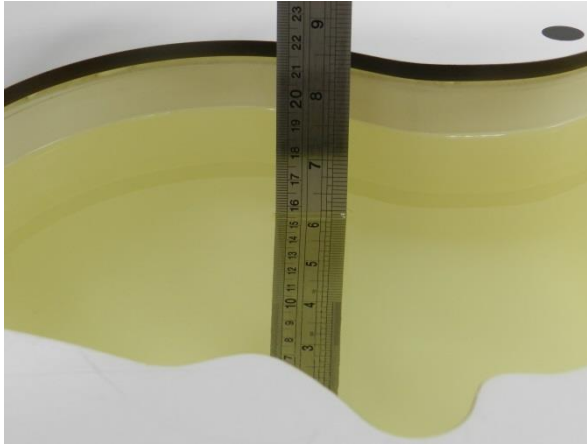

Fig 10.1 Photo of Liquid Height for Head SAR

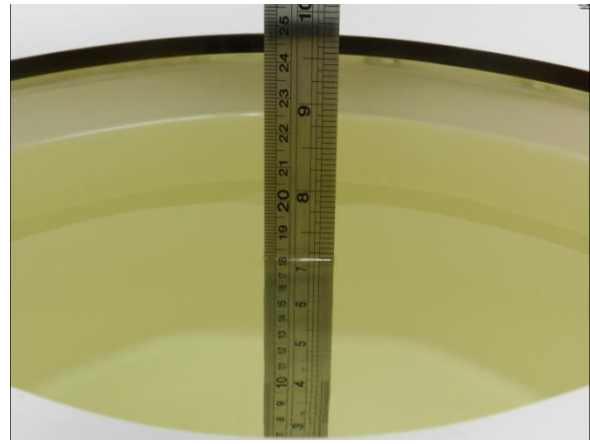

Fig 10.2 Photo of Liquid Height for Body SAR

11.2 Tissue Verification

The following tissue formulations are provided for reference only as some of the parameters have not been thoroughly verified. The composition of ingredients may be modified accordingly to achieve the desired target tissue parameters required for routine SAR evaluation.

Frequency (MHz)	Water (%)	Sugar (%)	Cellulose (%)	Salt (%)	Preventol (%)	DGBE (%)	Conductivity (σ)	Permittivity (ϵ_r)
For Head								
835	40.3	57.9	0.2	1.4	0.2	0	0.90	41.5
1800, 1900, 2000	55.2	0	0	0.3	0	44.5	1.40	40.0
2450	55.0	0	0	0	0	45.0	1.80	39.2
2600	54.8	0	0	0.1	0	45.1	1.96	39.0
For Body								
835	50.8	48.2	0	0.9	0.1	0	0.97	55.2
1800, 1900, 2000	70.2	0	0	0.4	0	29.4	1.52	53.3
2450	68.6	0	0	0	0	31.4	1.95	52.7
2600	68.1	0	0	0.1	0	31.8	2.16	52.5

Simulating Liquid for 5GHz, Manufactured by SPEAG

Ingredients	(% by weight)
Water	64~78%
Mineral oil	11~18%
Emulsifiers	9~15%
Additives and Salt	2~3%

<Tissue Dielectric Parameter Check Results>

Frequency (MHz)	Tissue Type	Liquid Temp. (°C)	Conductivity (σ)	Permittivity (ϵ_r)	Conductivity Target (σ)	Permittivity Target (ϵ_r)	Delta (σ) (%)	Delta (ϵ_r) (%)	Limit (%)	Date
835	Head	22.6	0.914	42.773	0.90	41.50	1.56	3.07	±5	2018/7/4
1750	Head	22.7	1.353	40.644	1.37	40.10	-1.24	1.36	±5	2018/7/5
1900	Head	22.8	1.428	41.108	1.40	40.00	2.00	2.77	±5	2018/7/6
2450	Head	22.9	1.848	39.012	1.80	39.20	2.67	-0.48	±5	2018/7/7
2600	Head	22.6	2.021	38.375	1.96	39.00	3.11	-1.60	±5	2018/7/7
5250	Head	22.7	4.865	37.109	4.71	35.90	3.29	3.37	±5	2018/7/8
5600	Head	22.8	5.207	36.587	5.07	35.50	2.70	3.06	±5	2018/7/8
5750	Head	22.9	5.361	36.365	5.22	35.40	2.70	2.73	±5	2018/7/8
835	Body	22.6	0.984	56.510	0.97	55.20	1.44	2.37	±5	2018/7/7
1750	Body	22.7	1.491	54.729	1.49	53.40	0.07	2.49	±5	2018/7/8
1900	Body	22.7	1.537	53.469	1.52	53.30	1.12	0.32	±5	2018/7/9
2450	Body	22.9	2.017	53.033	1.95	52.70	3.44	0.63	±5	2018/7/8
2600	Body	22.6	2.231	52.422	2.16	52.50	3.29	-0.15	±5	2018/7/8
5250	Body	22.6	5.506	47.956	5.36	48.90	2.72	-1.93	±5	2018/7/9
5600	Body	22.7	5.954	47.367	5.77	48.50	3.19	-2.34	±5	2018/7/10
5750	Body	22.7	6.212	46.182	5.94	48.30	4.58	-4.39	±5	2018/7/10

11.3 System Performance Check Results

Comparing to the original SAR value provided by SPEAG, the verification data should be within its specification of 10 %. Below table shows the target SAR and measured SAR after normalized to 1W input power. The table below indicates the system performance check can meet the variation criterion and the plots can be referred to Appendix A of this report.

<1g SAR>

Date	Frequency (MHz)	Tissue Type	Input Power (mW)	Dipole S/N	Probe S/N	DAE S/N	Measured 1g SAR (W/kg)	Targeted 1g SAR (W/kg)	Normalized 1g SAR (W/kg)	Deviation (%)
2018/7/4	835	Head	250	4d091	3857	1210	2.46	9.48	9.84	3.80
2018/7/5	1750	Head	250	1069	3857	1210	9.08	37.00	36.32	-1.84
2018/7/6	1900	Head	250	5d118	3857	1210	9.89	39.70	39.56	-0.35
2018/7/7	2450	Head	250	840	3857	1210	12.80	52.60	51.2	-2.66
2018/7/7	2600	Head	250	1061	3857	1210	14.20	58.20	56.8	-2.41
2018/7/8	5250	Head	100	1006	3857	1210	7.75	78.30	77.5	-1.02
2018/7/8	5600	Head	100	1006	3857	1210	8.02	85.00	80.2	-5.65
2018/7/8	5750	Head	100	1006	3857	1210	7.24	78.50	72.4	-7.77
2018/7/7	835	Body	250	4d091	3857	1210	2.57	9.72	10.28	5.76
2018/7/8	1750	Body	250	1069	3857	1210	9.34	38.00	37.36	-1.68
2018/7/9	1900	Body	250	5d118	3857	1210	9.83	40.40	39.32	-2.67
2018/7/8	2450	Body	250	840	3857	1210	13.50	51.90	54	4.05
2018/7/8	2600	Body	250	1061	3857	1210	15.00	56.40	60	6.38
2018/7/9	5250	Body	100	1006	3857	1210	7.72	77.00	77.2	0.26
2018/7/10	5600	Body	100	1006	3857	1210	8.13	80.10	81.3	1.50
2018/7/10	5750	Body	100	1006	3857	1210	7.51	75.10	75.1	0.00

<10g SAR>

Date	Frequency (MHz)	Tissue Type	Input Power (mW)	Dipole S/N	Probe S/N	DAE S/N	Measured 10g SAR (W/kg)	Targeted 10g SAR (W/kg)	Normalized 10g SAR (W/kg)	Deviation (%)
2018/7/9	5250	Body	100	1006	3857	1210	2.14	21.30	21.4	0.47
2018/7/10	5600	Body	100	1006	3857	1210	2.28	22.40	22.8	1.79

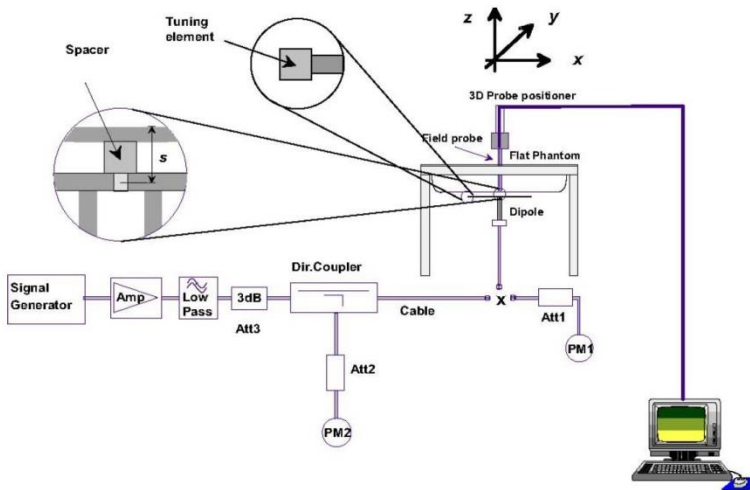

Fig 10.3.1 System Performance Check Setup



Fig 10.3.2 Setup Photo

12. RF Exposure Positions

12.1 Ear and handset reference point

Figure 11.1.1 shows the front, back, and side views of the SAM phantom. The center-of-mouth reference point is labeled "M," the left ear reference point (ERP) is marked "LE," and the right ERP is marked "RE." Each ERP is 15 mm along the B-M (back-mouth) line behind the entrance-to-ear-canal (EEC) point, as shown in Figure 11.1.2. The Reference Plane is defined as passing through the two ear reference points and point M. The line N-F (neck-front), also called the reference pivoting line, is normal to the Reference Plane and perpendicular to both a line passing through RE and LE and the B-M line (see Figure 11.1.3). Both N-F and B-M lines should be marked on the exterior of the phantom shell to facilitate handset positioning. Posterior to the N-F line the ear shape is a flat surface with 6 mm thickness at each ERP, and forward of the N-F line the ear is truncated, as illustrated in Figure 11.1.2. The ear truncation is introduced to preclude the ear lobe from interfering with handset tilt, which could lead to unstable positioning at the cheek.

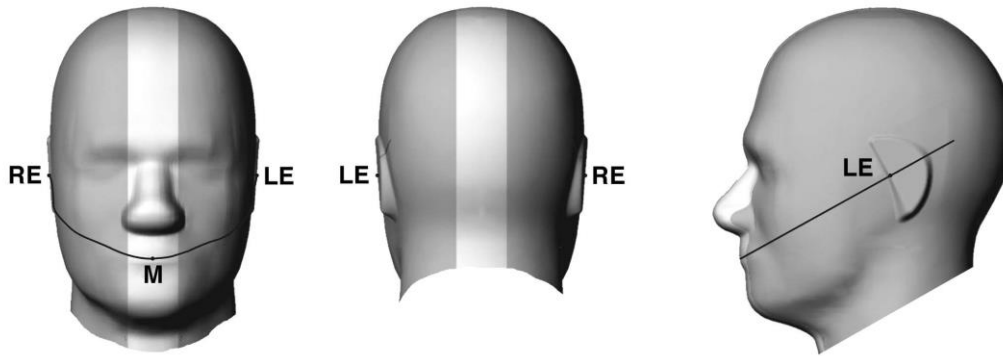

Fig 11.1.1 Front, back, and side views of SAM twin phantom

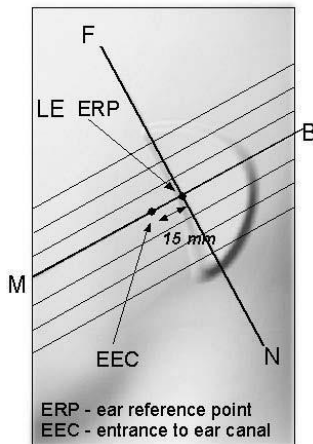

Fig 11.1.2 Close-up side view of phantom showing the ear region.

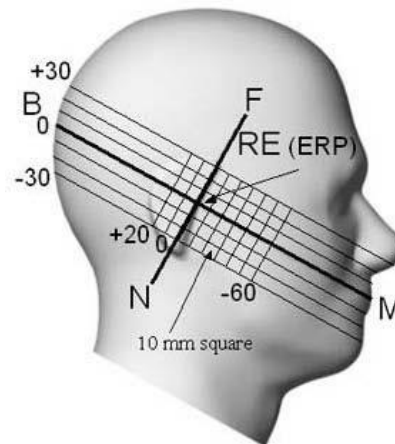

Fig 11.1.3 Side view of the phantom showing relevant markings and seven cross-sectional plane locations

12.2 Definition of the cheek position

1. Ready the handset for talk operation, if necessary. For example, for handsets with a cover piece (flip cover), open the cover. If the handset can transmit with the cover closed, both configurations must be tested.
2. Define two imaginary lines on the handset—the vertical centerline and the horizontal line. The vertical centerline passes through two points on the front side of the handset—the midpoint of the width w_t of the handset at the level of the acoustic output (point A in Figure 11.2.1 and Figure 11.2.2), and the midpoint of the width w_b of the bottom of the handset (point B). The horizontal line is perpendicular to the vertical centerline and passes through the center of the acoustic output (see Figure 11.2.1). The two lines intersect at point A. Note that for many handsets, point A coincides with the center of the acoustic output; however, the acoustic output may be located elsewhere on the horizontal line. Also note that the vertical centerline is not necessarily parallel to the front face of the handset (see Figure 11.2.2), especially for clamshell handsets, handsets with flip covers, and other irregularly-shaped handsets.
3. Position the handset close to the surface of the phantom such that point A is on the (virtual) extension of the line passing through points RE and LE on the phantom (see Figure 11.2.3), such that the plane defined by the vertical centerline and the horizontal line of the handset is approximately parallel to the sagittal plane of the phantom.
4. Translate the handset towards the phantom along the line passing through RE and LE until handset point A touches the pinna at the ERP.
5. While maintaining the handset in this plane, rotate it around the LE-RE line until the vertical centerline is in the plane normal to the plane containing B-M and N-F lines, i.e., the Reference Plane.
6. Rotate the handset around the vertical centerline until the handset (horizontal line) is parallel to the N-F line.
7. While maintaining the vertical centerline in the Reference Plane, keeping point A on the line passing through RE and LE, and maintaining the handset contact with the pinna, rotate the handset about the N-F line until any point on the handset is in contact with a phantom point below the pinna on the cheek. See Figure 11.2.3. The actual rotation angles should be documented in the test report.



Fig 11.2.1 Handset vertical and horizontal reference lines—"fixed case"

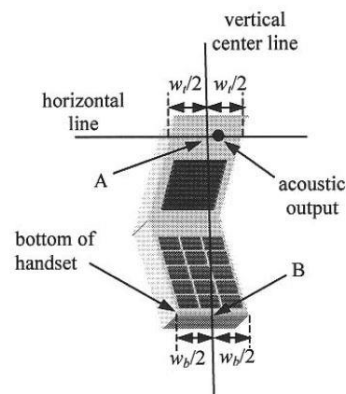

Fig 11.2.2 Handset vertical and horizontal reference lines—"clam-shell case"

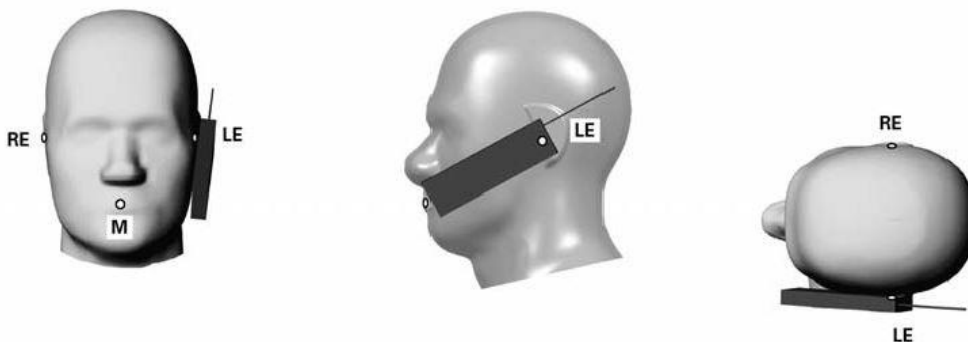

Fig 11.2.3 cheek or touch position. The reference points for the right ear (RE), left ear (LE), and mouth (M), which establish the Reference Plane for handset positioning, are indicated.

12.3 Definition of the tilt position

1. Ready the handset for talk operation, if necessary. For example, for handsets with a cover piece (flip cover), open the cover. If the handset can transmit with the cover closed, both configurations must be tested.
2. While maintaining the orientation of the handset, move the handset away from the pinna along the line passing through RE and LE far enough to allow a rotation of the handset away from the cheek by 15°.
3. Rotate the handset around the horizontal line by 15°.
4. While maintaining the orientation of the handset, move the handset towards the phantom on the line passing through RE and LE until any part of the handset touches the ear. The tilt position is obtained when the contact point is on the pinna. See Figure 11.3.1. If contact occurs at any location other than the pinna, e.g., the antenna at the back of the phantom head, the angle of the handset should be reduced. In this case, the tilt position is obtained if any point on the handset is in contact with the pinna and a second point

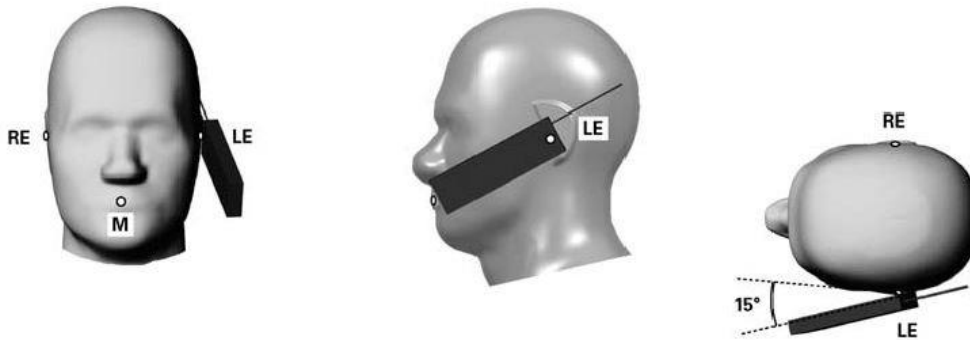

Fig 11.3.1 Tilt position. The reference points for the right ear (RE), left ear (LE), and mouth (M), which define the Reference Plane for handset positioning, are indicated.

12.4 Body Worn Accessory

Body-worn operating configurations are tested with the belt-clips and holsters attached to the device and positioned against a flat phantom in a normal use configuration (see Figure 11.4). Per KDB648474 D04v01r03, body-worn accessory exposure is typically related to voice mode operations when handsets are carried in body-worn accessories. The body-worn accessory procedures in FCC KDB 447498 D01v06 should be used to test for body-worn accessory SAR compliance, without a headset connected to it. This enables the test results for such configuration to be compatible with that required for hotspot mode when the body-worn accessory test separation distance is greater than or equal to that required for hotspot mode, when applicable. When the reported SAR for body-worn accessory, measured without a headset connected to the handset is $> 1.2 \text{ W/kg}$, the highest reported SAR configuration for that wireless mode and frequency band should be repeated for that body-worn accessory with a handset attached to the handset.

Accessories for body-worn operation configurations are divided into two categories: those that do not contain metallic components and those that do contain metallic components. When multiple accessories that do not contain metallic components are supplied with the device, the device is tested with only the accessory that dictates the closest spacing to the body. Then multiple accessories that contain metallic components are test with the device with each accessory. If multiple accessories share an identical metallic component (i.e. the same metallic belt-chip used with different holsters with no other metallic components) only the accessory that dictates the closest spacing to the body is tested.

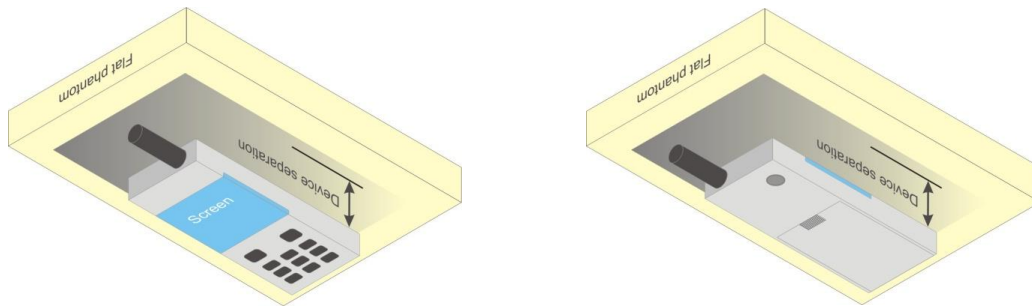

Fig 11.4 Body Worn Position



12.5 Product Specific 10g SAR Exposure

For smart phones with a display diagonal dimension > 15.0 cm or an overall diagonal dimension > 16.0 cm that provide similar mobile web access and multimedia support found in mini-tablets or UMPC mini-tablets that support voice calls next to the ear, According to KDB648474 D04v01r03, the following phablet procedures should be applied to evaluate SAR compliance for each applicable wireless modes and frequency band. Devices marketed as phablets, regardless of form factors and operating characteristics must be tested as a phablet to determine SAR compliance

1. The normally required head and body-worn accessory SAR test procedures for handsets, including hotspot mode, must be applied.
2. The UMPC mini-tablet procedures must also be applied to test the SAR of all surfaces and edges with an antenna located at ≤ 25 mm from that surface or edge, in direct contact with a flat phantom, for 10-g extremity SAR according to the body-equivalent tissue dielectric parameters in KDB 865664 to address interactive hand use exposure conditions.6 The UMPC mini-tablet 1-g SAR at 5 mm is not required. When hotspot mode applies, 10-g extremity SAR is required only for the surfaces and edges with hotspot mode 1-g reported SAR > 1.2 W/kg.

12.6 Wireless Router

Some battery-operated handsets have the capability to transmit and receive user through simultaneous transmission of WIFI simultaneously with a separate licensed transmitter. The FCC has provided guidance in FCC KDB Publication 941225 D06 v02r01 where SAR test considerations for handsets ($L \times W \geq 9$ cm x 5 cm) are based on a composite test separation distance of 10mm from the front, back and edges of the device containing transmitting antennas within 2.5cm of their edges, determined from general mixed use conditions for this type of devices. Since the hotspot SAR results may overlap with the body-worn accessory SAR requirements, the more conservative configurations can be considered, thus excluding some body-worn accessory SAR tests.

When the user enables the personal wireless router functions for the handset, actual operations include simultaneous transmission of both the WIFI transmitter and another licensed transmitter. Both transmitters often do not transmit at the same transmitting frequency and thus cannot be evaluated for SAR under actual use conditions due to the limitations of the SAR assessment probes. Therefore, SAR must be evaluated for each frequency transmission and mode separately and spatially summed with the WIFI transmitter according to FCC KDB Publication 447498 D01v06 publication procedures. The "Portable Hotspot" feature on the handset was NOT activated during SAR assessments, to ensure the SAR measurements were evaluated for a single transmission frequency RF signal at a time.

13. Conducted RF Output Power (Unit: dBm)

<GSM Conducted Power>

General Note:

1. Per KDB 447498 D01v06, the maximum output power channel is used for SAR testing and for further SAR test reduction.
2. Per KDB 941225 D01v03r01, for SAR test reduction for GSM / GPRS / EDGE modes is determined by the source-based time-averaged output power including tune-up tolerance. The mode with highest specified time-averaged output power should be tested for SAR compliance in the applicable exposure conditions. For modes with the same specified maximum output power and tolerance, the higher number time-slot configuration should be tested. Therefore, the GPRS 4Tx slots for GSM850/GSM1900 are considered as the primary mode.
3. Other configurations of GSM / GPRS / EDGE are considered as secondary modes. The 3G SAR test reduction procedure is applied, when the maximum output power and tune-up tolerance specified for production units in a secondary mode is $\leq \frac{1}{4}$ dB higher than the primary mode, SAR measurement is not required for the secondary mode.
4. Power reduction which is triggered by p-sensor on is implemented in GSM1900 band, for SAR testing EUT was set in reduced power mode and GPRS 4Tx slots due to its highest frame-average power.

<Maximum Average RF Power (Proximity Sensor Off)>

GSM850	Burst Average Power (dBm)			Tune-up Limit (dBm)	Frame-Average Power (dBm)			Tune-up Limit (dBm)
	Tx Channel	128	189		251	128	189	
Frequency (MHz)	824.2	836.4	848.8		824.2	836.4	848.8	
GSM 1 Tx slot	33.25	33.06	33.15	33.50	24.25	24.06	24.15	24.50
GPRS 1 Tx slot	33.24	33.04	33.13	33.50	24.24	24.04	24.13	24.50
GPRS 2 Tx slots	31.57	31.79	31.94	32.50	25.57	25.79	25.94	26.50
GPRS 3 Tx slots	30.33	30.24	30.37	31.00	26.07	25.98	26.11	26.74
GPRS 4 Tx slots	28.97	28.91	29.04	30.00	25.97	25.91	26.04	27.00
EDGE 1 Tx slot	27.48	27.42	27.37	28.50	18.48	18.42	18.37	19.50
EDGE 2 Tx slots	26.04	26.00	25.96	27.00	20.04	20.00	19.96	21.00
EDGE 3 Tx slots	24.78	24.74	24.71	26.00	20.52	20.48	20.45	21.74
EDGE 4 Tx slots	23.02	22.98	23.00	24.50	20.02	19.98	20.00	21.50
GSM1900	Burst Average Power (dBm)			Tune-up Limit (dBm)	Frame-Average Power (dBm)			Tune-up Limit (dBm)
Tx Channel	512	661	810		512	661	810	
Frequency (MHz)	1850.2	1880	1909.8		1850.2	1880	1909.8	
GSM 1 Tx slot	31.19	31.02	31.13	32.00	22.19	22.02	22.13	23.00
GPRS 1 Tx slot	31.18	31.00	31.12	32.00	22.18	22.00	22.12	23.00
GPRS 2 Tx slots	28.40	28.27	28.12	29.00	22.40	22.27	22.12	23.00
GPRS 3 Tx slots	27.24	26.97	26.84	28.00	22.98	22.71	22.58	23.74
GPRS 4 Tx slots	26.03	25.77	25.64	27.00	23.03	22.77	22.64	24.00
EDGE 1 Tx slot	26.64	26.38	26.19	27.50	17.64	17.38	17.19	18.50
EDGE 2 Tx slots	24.68	24.47	24.28	25.50	18.68	18.47	18.28	19.50
EDGE 3 Tx slots	23.50	23.23	23.04	24.50	19.24	18.97	18.78	20.24
EDGE 4 Tx slots	21.31	21.08	21.02	23.00	18.31	18.08	18.02	20.00

Remark: The frame-averaged power is linearly scaled the maximum burst averaged power over 8 time slots.

The calculated method are shown as below:

- Frame-averaged power = Maximum burst averaged power (1 Tx Slot) - 9 dB
- Frame-averaged power = Maximum burst averaged power (2 Tx Slots) - 6 dB
- Frame-averaged power = Maximum burst averaged power (3 Tx Slots) - 4.26 dB
- Frame-averaged power = Maximum burst averaged power (4 Tx Slots) - 3 dB



<Maximum Average RF Power (Proximity Sensor On)>

GSM1900 Tx Channel	Burst Average Power (dBm)			Tune-up Limit (dBm)	Frame-Average Power (dBm)			Tune-up Limit (dBm)
	512	661	810		512	661	810	
Frequency (MHz)	1850.2	1880	1909.8		1850.2	1880	1909.8	
GSM 1 Tx slot	23.66	23.45	23.27	25.00	14.66	14.45	14.27	16.00
GPRS 1 Tx slot	23.64	23.44	23.25	25.00	14.64	14.44	14.25	16.00
GPRS 2 Tx slots	23.40	23.21	23.02	25.00	17.40	17.21	17.02	19.00
GPRS 3 Tx slots	23.28	23.03	22.83	24.50	19.02	18.77	18.57	20.24
GPRS 4 Tx slots	23.08	22.84	22.68	23.50	20.08	19.84	19.68	20.50
EDGE 1 Tx slot	23.60	23.30	23.11	25.00	14.60	14.30	14.11	16.00
EDGE 2 Tx slots	23.25	22.94	22.78	24.50	17.25	16.94	16.78	18.50
EDGE 3 Tx slots	23.01	22.70	22.53	24.00	18.75	18.44	18.27	19.74
EDGE 4 Tx slots	21.27	21.01	20.86	22.50	18.27	18.01	17.86	19.50

Remark: The frame-averaged power is linearly scaled the maximum burst averaged power over 8 time slots.

The calculated method are shown as below:

- Frame-averaged power = Maximum burst averaged power (1 Tx Slot) - 9 dB
- Frame-averaged power = Maximum burst averaged power (2 Tx Slots) - 6 dB
- Frame-averaged power = Maximum burst averaged power (3 Tx Slots) - 4.26 dB
- Frame-averaged power = Maximum burst averaged power (4 Tx Slots) - 3 dB

<WCDMA Conducted Power>

1. The following tests were conducted according to the test requirements outlines in 3GPP TS 34.121 specification.
2. The procedures in KDB 941225 D01v03r01 are applied for 3GPP Rel. 6 HSPA to configure the device in the required sub-test mode(s) to determine SAR test exclusion.
3. For DC-HSDPA, the device was configured according to the H-Set 12, Fixed Reference Channel (FRC) configuration in Table C.8.1.12 of 3GPP TS 34.121-1, with the primary and the secondary serving HS-DSCH Cell enabled during the power measurement.

A summary of these settings are illustrated below:

HSDPA Setup Configuration:

- a. The EUT was connected to Base Station Agilent E5515C referred to the Setup Configuration.
- b. The RF path losses were compensated into the measurements.
- c. A call was established between EUT and Base Station with following setting:
 - i. Set Gain Factors (β_c and β_d) and parameters were set according to each
 - ii. Specific sub-test in the following table, C10.1.4, quoted from the TS 34.121
 - iii. Set RMC 12.2Kbps + HSDPA mode.
 - iv. Set Cell Power = -86 dBm
 - v. Set HS-DSCH Configuration Type to FRC (H-set 1, QPSK)
 - vi. Select HSDPA Uplink Parameters
 - vii. Set Delta ACK, Delta NACK and Delta CQI = 8
 - viii. Set Ack-Nack Repetition Factor to 3
 - ix. Set CQI Feedback Cycle (k) to 4 ms
 - x. Set CQI Repetition Factor to 2
 - xi. Power Ctrl Mode = All Up bits
- d. The transmitted maximum output power was recorded.

Table C.10.1.4: β values for transmitter characteristics tests with HS-DPCCH

Sub-test	β_c	β_d	β_d (SF)	β_c/β_d	β_{HS} (Note 1, Note 2)	CM (dB) (Note 3)	MPR (dB) (Note 3)
1	2/15	15/15	64	2/15	4/15	0.0	0.0
2	12/15 (Note 4)	15/15 (Note 4)	64	12/15 (Note 4)	24/15	1.0	0.0
3	15/15	8/15	64	15/8	30/15	1.5	0.5
4	15/15	4/15	64	15/4	30/15	1.5	0.5

Note 1: $\Delta_{ACK}, \Delta_{NACK}$ and $\Delta_{CQI} = 30/15$ with $\beta_{HS} = 30/15 * \beta_c$.

Note 2: For the HS-DPCCH power mask requirement test in clause 5.2C, 5.7A, and the Error Vector Magnitude (EVM) with HS-DPCCH test in clause 5.13.1A, and HSDPA EVM with phase discontinuity in clause 5.13.1AA, Δ_{ACK} and $\Delta_{NACK} = 30/15$ with $\beta_{HS} = 30/15 * \beta_c$, and $\Delta_{CQI} = 24/15$ with $\beta_{HS} = 24/15 * \beta_c$.

Note 3: CM = 1 for $\beta_c/\beta_d = 12/15, \beta_{HS}/\beta_c = 24/15$. For all other combinations of DPCCH, DPDCCH and HS-DPCCH the MPR is based on the relative CM difference. This is applicable for only UEs that support HSDPA in release 6 and later releases.

Note 4: For subtest 2 the β_c/β_d ratio of 12/15 for the TFC during the measurement period (TF1, TF0) is achieved by setting the signalled gain factors for the reference TFC (TF1, TF1) to $\beta_c = 11/15$ and $\beta_d = 15/15$.

Setup Configuration

HSUPA Setup Configuration:

- a. The EUT was connected to Base Station Agilent E5515C referred to the Setup Configuration.
- b. The RF path losses were compensated into the measurements.
- c. A call was established between EUT and Base Station with following setting * :
 - i. Call Configs = 5.2B, 5.9B, 5.10B, and 5.13.2B with QPSK
 - ii. Set the Gain Factors (β_c and β_d) and parameters (AG Index) were set according to each specific sub-test in the following table, C11.1.3, quoted from the TS 34.121
 - iii. Set Cell Power = -86 dBm
 - iv. Set Channel Type = 12.2k + HSPA
 - v. Set UE Target Power
 - vi. Power Ctrl Mode= Alternating bits
 - vii. Set and observe the E-TFCl
 - viii. Confirm that E-TFCl is equal to the target E-TFCl of 75 for sub-test 1, and other subtest's E-TFCl
- d. The transmitted maximum output power was recorded.

Table C.11.1.3: β values for transmitter characteristics tests with HS-DPCCH and E-DCH

Sub-test	β_c	β_d	β_d (SF)	β_c/β_d	β_{HS} (Note1)	β_{ec}	β_{ed} (Note 4) (Note 5)	β_{ed} (SF)	β_{ed} (Codes)	CM (dB) (Note 2)	MPR (dB) (Note 2) (Note 6)	AG Index (Note 5)	E-TFCl
1	11/15 (Note 3)	15/15 (Note 3)	64	11/15 (Note 3)	22/15	209/25	1309/225	4	1	1.0	0.0	20	75
2	6/15	15/15	64	6/15	12/15	12/15	94/75	4	1	3.0	2.0	12	67
3	15/15	9/15	64	15/9	30/15	30/15	$\beta_{ed1}: 47/15$ $\beta_{ed2}: 47/15$	4 4	2	2.0	1.0	15	92
4	2/15	15/15	64	2/15	4/15	2/15	56/75	4	1	3.0	2.0	17	71
5	15/15	0	-	-	5/15	5/15	47/15	4	1	1.0	0.0	12	67

Note 1: For sub-test 1 to 4, Δ_{ACK} , Δ_{NACK} and $\Delta_{CQI} = 30/15$ with $\beta_{hs} = 30/15 * \beta_c$. For sub-test 5, Δ_{ACK} , Δ_{NACK} and $\Delta_{CQI} = 5/15$ with $\beta_{hs} = 5/15 * \beta_c$.

Note 2: CM = 1 for $\beta_c/\beta_d = 12/15$, $\beta_{hs}/\beta_c = 24/15$. For all other combinations of DPDCH, DPCCH, HS-DPCCH, E-DPDCH and E-DPCCH the MPR is based on the relative CM difference.

Note 3: For subtest 1 the β_c/β_d ratio of 11/15 for the TFC during the measurement period (TF1, TF0) is achieved by setting the signalled gain factors for the reference TFC (TF1, TF1) to $\beta_c = 10/15$ and $\beta_d = 15/15$.

Note 4: In case of testing by UE using E-DPDCH Physical Layer category 1, Sub-test 3 is omitted according to TS25.306 Table 5.1g.

Note 5: β_{ed} can not be set directly; it is set by Absolute Grant Value.

Note 6: For subtests 2, 3 and 4, UE may perform E-DPDCH power scaling at max power which could results in slightly smaller MPR values.

Setup Configuration

DC-HSDPA 3GPP release 8 Setup Configuration:

- a. The EUT was connected to Base Station Agilent E5515C referred to the Setup Configuration below
- b. The RF path losses were compensated into the measurements.
- c. A call was established between EUT and Base Station with following setting:
 - i. Set RMC 12.2Kbps + HSDPA mode.
 - ii. Set Cell Power = -25 dBm
 - iii. Set HS-DSCH Configuration Type to FRC (H-set 12, QPSK)
 - iv. Select HSDPA Uplink Parameters
 - v. Set Gain Factors (β_c and β_d) and parameters were set according to each Specific sub-test in the following table, C10.1.4, quoted from the TS 34.121
 - a). Subtest 1: $\beta_c/\beta_d=2/15$
 - b). Subtest 2: $\beta_c/\beta_d=12/15$
 - c). Subtest 3: $\beta_c/\beta_d=15/8$
 - d). Subtest 4: $\beta_c/\beta_d=15/4$
 - vi. Set Delta ACK, Delta NACK and Delta CQI = 8
 - vii. Set Ack-Nack Repetition Factor to 3
 - viii. Set CQI Feedback Cycle (k) to 4 ms
 - ix. Set CQI Repetition Factor to 2
 - x. Power Ctrl Mode = All Up bits
- d. The transmitted maximum output power was recorded.

The following tests were conducted according to the test requirements outlines in 3GPP TS 34.121 specification. A summary of these settings are illustrated below:

C.8.1.12 Fixed Reference Channel Definition H-Set 12

Table C.8.1.12: Fixed Reference Channel H-Set 12

Parameter	Unit	Value
Nominal Avg. Inf. Bit Rate	kbps	60
Inter-TTI Distance	TTI's	1
Number of HARQ Processes	Processes	6
Information Bit Payload (N_{INF})	Bits	120
Number Code Blocks	Blocks	1
Binary Channel Bits Per TTI	Bits	960
Total Available SML's in UE	SML's	19200
Number of SML's per HARQ Proc.	SML's	3200
Coding Rate		0.15
Number of Physical Channel Codes	Codes	1
Modulation		QPSK
Note 1: The RMC is intended to be used for DC-HSDPA mode and both cells shall transmit with identical parameters as listed in the table. Note 2: Maximum number of transmission is limited to 1, i.e., retransmission is not allowed. The redundancy and constellation version 0 shall be used.		

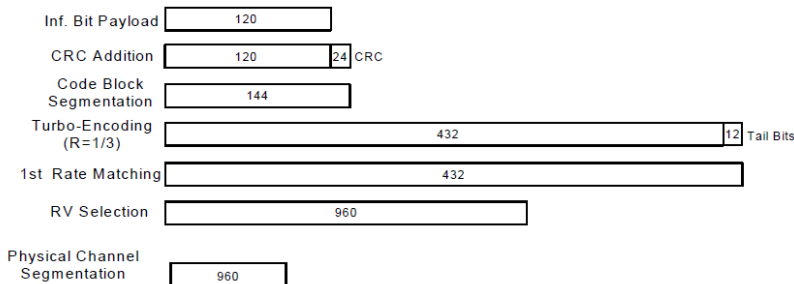

Figure C.8.19: Coding rate for Fixed reference Channel H-Set 12 (QPSK)

Setup Configuration



<WCDMA Conducted Power>

General Note:

1. Per KDB 941225 D01v03r01, for SAR testing is measured using a 12.2 kbps RMC with TPC bits configured to all "1's".
2. Per KDB 941225 D01v03r01, RMC 12.2kbps setting is used to evaluate SAR. The maximum output power and tune-up tolerance specified for production units in HSDPA / HSUPA / DC-HSDPA is $\leq \frac{1}{4}$ dB higher than RMC 12.2Kbps or when the highest reported SAR of the RMC12.2Kbps is scaled by the ratio of specified maximum output power and tune-up tolerance of HSDPA / HSUPA / DC-HSDPA to RMC12.2Kbps and the adjusted SAR is ≤ 1.2 W/kg, SAR measurement is not required for HSDPA / HSUPA / DC-HSDPA, and according to the following RF output power, the output power results of the secondary modes (HSDPA / HSUPA / DC-HSDPA) are less than $\frac{1}{4}$ dB higher than the primary modes; therefore, SAR measurement is not required for HSDPA / HSUPA / DC-HSDPA.

<Maximum Average RF Power (Proximity Sensor Off)>

Band		WCDMA Band II			Tune-up Limit (dBm)	WCDMA Band IV			Tune-up Limit (dBm)	WCDMA Band V			Tune-up Limit (dBm)
Tx Channel		9262	9400	9538		1312	1413	1513		4132	4182	4233	
Rx Channel		9662	9800	9938		1537	1638	1738		4357	4407	4458	
Frequency (MHz)		1852.4	1880	1907.6		1712.4	1732.6	1752.6		826.4	836.4	846.6	
3GPP Rel 99	AMR 12.2Kbps	23.40	23.30	23.27	24.00	24.39	24.57	24.52	25.00	23.50	23.53	23.56	24.00
3GPP Rel 99	RMC 12.2Kbps	23.41	23.32	23.28	24.00	24.40	24.59	24.53	25.00	23.51	23.55	23.58	24.00
3GPP Rel 6	HSDPA Subtest-1	22.15	22.07	22.04	23.00	22.87	23.13	23.15	24.00	22.20	22.18	22.17	23.00
3GPP Rel 6	HSDPA Subtest-2	22.17	22.08	22.05	23.00	22.90	23.16	22.93	24.00	22.25	22.14	22.19	23.00
3GPP Rel 6	HSDPA Subtest-3	21.71	21.61	21.56	22.50	22.42	22.68	22.63	23.50	21.75	21.72	21.64	22.50
3GPP Rel 6	HSDPA Subtest-4	21.70	21.60	21.57	22.50	22.43	22.69	22.63	23.50	21.76	21.71	21.69	22.50
3GPP Rel 8	DC-HSDPA Subtest-1	22.08	22.00	22.00	23.00	22.76	22.89	22.98	24.00	22.02	22.10	22.07	23.00
3GPP Rel 8	DC-HSDPA Subtest-2	22.07	21.98	21.98	23.00	22.70	22.85	22.93	24.00	21.95	22.08	22.08	23.00
3GPP Rel 8	DC-HSDPA Subtest-3	21.67	21.56	21.45	22.50	22.29	22.54	22.43	23.50	21.54	21.65	21.52	22.50
3GPP Rel 8	DC-HSDPA Subtest-4	21.62	21.52	21.50	22.50	22.25	22.50	22.40	23.50	21.50	21.50	21.55	22.50
3GPP Rel 6	HSUPA Subtest-1	22.14	22.03	22.00	23.00	22.88	23.07	23.12	24.00	22.17	22.13	22.12	23.00
3GPP Rel 6	HSUPA Subtest-2	20.17	20.01	19.89	21.00	20.84	21.03	21.11	22.00	20.18	20.09	20.09	21.00
3GPP Rel 6	HSUPA Subtest-3	20.95	20.97	20.95	22.00	21.83	22.00	21.89	23.00	21.15	21.13	21.13	22.00
3GPP Rel 6	HSUPA Subtest-4	20.10	20.07	19.97	21.00	20.88	21.07	21.10	22.00	19.98	19.95	19.90	21.00
3GPP Rel 6	HSUPA Subtest-5	22.20	22.00	22.00	23.00	22.90	23.10	23.10	24.00	22.20	22.10	22.10	23.00



<Maximum Average RF Power (Proximity Sensor On)>

Band		WCDMA Band II			Tune-up Limit (dBm)	WCDMA Band IV			Tune-up Limit (dBm)
Tx Channel		9262	9400	9538		1312	1413	1513	
Rx Channel		9662	9800	9938		1537	1638	1738	
Frequency (MHz)		1852.4	1880	1907.6		1712.4	1732.6	1752.6	
3GPP Rel 99	AMR 12.2Kbps	20.09	19.89	19.94	20.50	20.06	20.27	20.21	21.50
3GPP Rel 99	RMC 12.2Kbps	20.10	19.93	19.95	20.50	20.08	20.28	20.23	21.50
3GPP Rel 6	HSDPA Subtest-1	19.76	19.72	19.70	20.00	19.20	19.41	19.31	20.50
3GPP Rel 6	HSDPA Subtest-2	19.73	19.74	19.72	20.00	19.22	19.39	19.30	20.50
3GPP Rel 6	HSDPA Subtest-3	19.23	19.22	19.27	19.50	18.70	18.88	18.77	20.00
3GPP Rel 6	HSDPA Subtest-4	19.21	19.29	19.19	19.50	18.67	18.85	18.79	20.00
3GPP Rel 8	DC-HSDPA Subtest-1	19.64	19.67	19.68	20.00	18.97	19.11	19.08	20.50
3GPP Rel 8	DC-HSDPA Subtest-2	19.64	19.67	19.68	20.00	19.08	19.29	19.19	20.50
3GPP Rel 8	DC-HSDPA Subtest-3	19.23	19.26	19.27	19.50	18.72	18.89	18.80	20.00
3GPP Rel 8	DC-HSDPA Subtest-4	19.18	19.21	19.22	19.50	18.65	18.83	18.72	20.00
3GPP Rel 6	HSUPA Subtest-1	19.68	19.73	19.64	20.00	19.24	19.37	19.28	20.50
3GPP Rel 6	HSUPA Subtest-2	17.70	17.76	17.68	18.00	17.18	17.40	17.25	18.50
3GPP Rel 6	HSUPA Subtest-3	18.68	18.72	18.67	19.00	18.21	18.37	18.27	19.50
3GPP Rel 6	HSUPA Subtest-4	17.68	17.66	17.65	18.00	17.23	17.37	17.34	18.50
3GPP Rel 6	HSUPA Subtest-5	19.70	19.70	19.70	20.00	19.20	19.40	19.30	20.50

<LTE Conducted Power>

General Note:

1. Anritsu MT8820C base station simulator was used to setup the connection with EUT; the frequency band, channel bandwidth, RB allocation configuration, modulation type are set in the base station simulator to configure EUT transmitting at maximum power and at different configurations which are requested to be reported to FCC, for conducted power measurement and SAR testing.
2. Per KDB 941225 D05v02r05, when a properly configured base station simulator is used for the SAR and power measurements, spectrum plots for each RB allocation and offset configuration is not required.
3. Per KDB 941225 D05v02r05, start with the largest channel bandwidth and measure SAR for QPSK with 1 RB allocation, using the RB offset and required test channel combination with the highest maximum output power for RB offsets at the upper edge, middle and lower edge of each required test channel.
4. Per KDB 941225 D05v02r05, 50% RB allocation for QPSK SAR testing follows 1RB QPSK allocation procedure.
5. Per KDB 941225 D05v02r05, for QPSK with 100% RB allocation, SAR is not required when the highest maximum output power for 100 % RB allocation is less than the highest maximum output power in 50% and 1 RB allocations and the highest reported SAR for 1 RB and 50% RB allocation are ≤ 0.8 W/kg. Otherwise, SAR is measured for the highest output power channel; and if the reported SAR is > 1.45 W/kg, the remaining required test channels must also be tested.
6. Per KDB 941225 D05v02r05, 16QAM/64QAM output power for each RB allocation configuration is $>$ not $\frac{1}{2}$ dB higher than the same configuration in QPSK and the reported SAR for the QPSK configuration is ≤ 1.45 W/kg; Per KDB 941225 D05v02r05, 16QAM/64QAM SAR testing is not required.
7. Per KDB 941225 D05v02r05, smaller bandwidth output power for each RB allocation configuration is $>$ not $\frac{1}{2}$ dB higher than the same configuration in the largest supported bandwidth, and the reported SAR for the largest supported bandwidth is ≤ 1.45 W/kg; Per KDB 941225 D05v02r05, smaller bandwidth SAR testing is not required.
8. For LTE B4 / B5 / B38 the maximum bandwidth does not support three non-overlapping channels, per KDB 941225 D05v02r05, when a device supports overlapping channel assignment in a channel bandwidth configuration, the middle channel of the group of overlapping channels should be selected for testing.
9. According to 2017 TCB workshop, for 64QAM and 16QAM should be verified by checking the signal constellation with a call box to avoid incorrect maximum power levels due to MPR and other requirements associated with signal modulation, and the following figure is taken from the "Fundamental Measurement >> Modulation Analysis >> constellation" mode of the device connect to the MT8821C base station, therefore, the device 64QAM and 16QAM signal modulation are correct.



64QAM

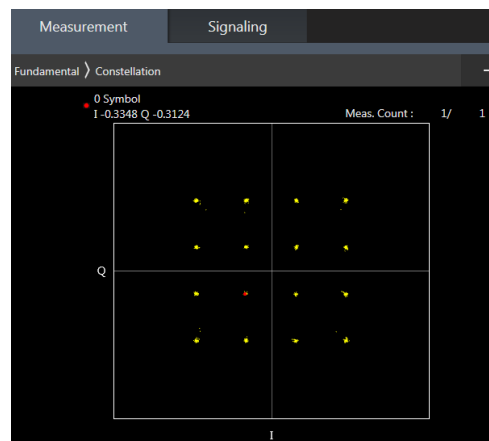

16QAM



<Maximum Average RF Power (Proximity Sensor Off)>

<LTE Band 4>

BW [MHz]	Modulation	RB Size	RB Offset	Power Low Ch. / Freq.	Power Middle Ch. / Freq.	Power High Ch. / Freq.	Tune-up limit (dBm)	MPR (dB)
Channel				20050	20175	20300		
Frequency (MHz)				1720	1732.5	1745		
20	QPSK	1	0	22.93	23.06	23.27	24	0
20	QPSK	1	49	22.81	22.98	23.05		
20	QPSK	1	99	22.91	22.99	22.83		
20	QPSK	50	0	21.91	22.09	22.20	23	1
20	QPSK	50	24	21.89	22.08	22.13		
20	QPSK	50	50	21.90	22.05	21.98		
20	QPSK	100	0	21.91	22.07	22.11		
20	16QAM	1	0	22.35	22.48	22.67	23	1
20	16QAM	1	49	22.20	22.44	22.45		
20	16QAM	1	99	22.36	22.41	22.19		
20	16QAM	50	0	21.02	21.24	21.34	22	2
20	16QAM	50	24	21.01	21.22	21.27		
20	16QAM	50	50	21.03	21.16	21.10		
20	16QAM	100	0	20.99	21.18	21.20		
20	64QAM	1	0	21.30	21.42	21.60	22	2
20	64QAM	1	49	21.15	21.37	21.40		
20	64QAM	1	99	21.23	21.34	21.11		
20	64QAM	50	0	20.03	20.24	20.36	21	3
20	64QAM	50	24	20.02	20.21	20.26		
20	64QAM	50	50	20.08	20.19	20.13		
20	64QAM	100	0	20.07	20.21	20.23		



Channel				20025	20175	20325	Tune-up limit (dBm)	MPR (dB)
Frequency (MHz)				1717.5	1732.5	1747.5		
15	QPSK	1	0	22.95	23.09	23.26	24	0
15	QPSK	1	37	22.76	23.03	22.97		
15	QPSK	1	74	22.92	23.08	22.86		
15	QPSK	36	0	21.86	22.08	22.18	23	1
15	QPSK	36	20	21.89	22.11	22.11		
15	QPSK	36	39	21.85	22.11	21.96		
15	QPSK	75	0	21.87	22.05	22.04	23	1
15	16QAM	1	0	22.32	22.53	22.63		
15	16QAM	1	37	22.11	22.45	22.36		
15	16QAM	1	74	22.26	22.45	22.20	22	2
15	16QAM	36	0	21.01	21.22	21.31		
15	16QAM	36	20	20.99	21.23	21.21		
15	16QAM	36	39	21.00	21.21	21.08	22	2
15	16QAM	75	0	20.96	21.23	21.16		
15	64QAM	1	0	21.23	21.42	21.61		
15	64QAM	1	37	21.06	21.33	21.31	22	2
15	64QAM	1	74	21.23	21.41	21.17		
15	64QAM	36	0	20.07	20.26	20.36		
15	64QAM	36	20	20.05	20.28	20.26	21	3
15	64QAM	36	39	20.05	20.29	20.13		
15	64QAM	75	0	20.00	20.23	20.21		
Channel				20000	20175	20350	Tune-up limit (dBm)	MPR (dB)
Frequency (MHz)				1715	1732.5	1750		
10	QPSK	1	0	22.62	23.02	23.08	24	0
10	QPSK	1	25	22.59	23.09	23.02		
10	QPSK	1	49	22.65	23.08	22.93		
10	QPSK	25	0	21.65	22.12	22.01	23	1
10	QPSK	25	12	21.64	22.08	22.05		
10	QPSK	25	25	21.65	22.06	21.96		
10	QPSK	50	0	21.74	22.03	21.98	23	1
10	16QAM	1	0	22.16	22.55	22.79		
10	16QAM	1	25	21.97	22.57	22.52		
10	16QAM	1	49	22.06	22.44	22.41	22	2
10	16QAM	25	0	20.79	21.14	21.17		
10	16QAM	25	12	20.80	21.13	21.00		
10	16QAM	25	25	20.73	21.10	21.02	22	2
10	16QAM	50	0	20.82	21.09	21.08		
10	64QAM	1	0	21.22	21.44	21.42		
10	64QAM	1	25	21.02	21.39	21.37	22	2
10	64QAM	1	49	21.15	21.38	21.16		
10	64QAM	25	0	19.96	20.27	20.25		
10	64QAM	25	12	19.95	20.29	20.20	21	3
10	64QAM	25	25	19.92	20.25	20.11		
10	64QAM	50	0	19.94	20.27	20.20		



Channel				19975	20175	20375	Tune-up limit (dBm)	MPR (dB)
Frequency (MHz)				1712.5	1732.5	1752.5		
5	QPSK	1	0	22.82	23.05	23.07	24	0
5	QPSK	1	12	22.71	23.03	22.82		
5	QPSK	1	24	22.62	23.17	22.90		
5	QPSK	12	0	21.71	22.08	21.96	23	1
5	QPSK	12	7	21.71	22.09	21.98		
5	QPSK	12	13	21.68	22.08	21.88		
5	QPSK	25	0	21.61	22.02	21.91	23	1
5	16QAM	1	0	21.97	22.21	21.98		
5	16QAM	1	12	21.88	22.26	21.86		
5	16QAM	1	24	21.78	22.27	21.80	22	2
5	16QAM	12	0	20.87	21.34	21.20		
5	16QAM	12	7	20.95	21.24	21.13		
5	16QAM	12	13	20.85	21.23	21.02	22	2
5	16QAM	25	0	20.88	21.18	21.01		
5	64QAM	1	0	21.15	21.45	21.37		
5	64QAM	1	12	21.05	21.43	21.21	22	2
5	64QAM	1	24	21.00	21.45	21.21		
5	64QAM	12	0	20.02	20.33	20.19		
5	64QAM	12	7	20.00	20.36	20.18	21	3
5	64QAM	12	13	19.98	20.31	20.14		
5	64QAM	25	0	19.91	20.24	20.08		
Channel				19965	20175	20385	Tune-up limit (dBm)	MPR (dB)
Frequency (MHz)				1711.5	1732.5	1753.5		
3	QPSK	1	0	22.71	22.95	22.76	24	0
3	QPSK	1	8	22.74	22.97	22.89		
3	QPSK	1	14	22.61	22.95	22.69		
3	QPSK	8	0	21.64	22.07	21.86	23	1
3	QPSK	8	4	21.63	22.03	21.95		
3	QPSK	8	7	21.62	22.02	21.95		
3	QPSK	15	0	21.68	22.03	21.95	23	1
3	16QAM	1	0	21.76	22.21	22.12		
3	16QAM	1	8	21.84	22.37	22.20		
3	16QAM	1	14	21.69	22.26	22.10	22	2
3	16QAM	8	0	20.77	21.20	21.11		
3	16QAM	8	4	20.77	21.17	21.09		
3	16QAM	8	7	20.75	21.27	21.00	22	2
3	16QAM	15	0	20.71	21.11	21.08		
3	64QAM	1	0	21.06	21.43	21.20		
3	64QAM	1	8	21.13	21.44	21.23	22	2
3	64QAM	1	14	21.01	21.39	21.13		
3	64QAM	8	0	19.96	20.31	20.15		
3	64QAM	8	4	19.94	20.32	20.11	21	3
3	64QAM	8	7	19.94	20.32	20.08		
3	64QAM	15	0	19.95	20.23	20.05		



Channel				19957	20175	20393	Tune-up limit (dBm)	MPR (dB)
Frequency (MHz)				1710.7	1732.5	1754.3		
1.4	QPSK	1	0	22.61	22.78	22.69	24	0
1.4	QPSK	1	3	22.69	22.82	22.91		
1.4	QPSK	1	5	22.49	22.85	22.63		
1.4	QPSK	3	0	22.66	22.99	22.75		
1.4	QPSK	3	1	22.71	23.00	22.79		
1.4	QPSK	3	3	22.53	23.00	22.84		
1.4	QPSK	6	0	21.54	22.01	21.76	23	1
1.4	16QAM	1	0	21.86	22.18	21.78	23	1
1.4	16QAM	1	3	21.89	22.34	21.82		
1.4	16QAM	1	5	21.79	22.13	21.76		
1.4	16QAM	3	0	21.68	22.08	21.92		
1.4	16QAM	3	1	21.76	22.12	21.96		
1.4	16QAM	3	3	21.68	22.11	21.87		
1.4	16QAM	6	0	20.73	21.09	20.91	22	2
1.4	64QAM	1	0	21.06	21.48	21.23	22	2
1.4	64QAM	1	3	21.11	21.44	21.30		
1.4	64QAM	1	5	21.00	21.33	21.19		
1.4	64QAM	3	0	21.08	21.33	21.19		
1.4	64QAM	3	1	21.05	21.29	21.15		
1.4	64QAM	3	3	21.05	21.39	21.15		
1.4	64QAM	6	0	20.01	20.11	20.03	21	3



<LTE Band 5>

BW [MHz]	Modulation	RB Size	RB Offset	Power Low Ch. / Freq.	Power Middle Ch. / Freq.	Power High Ch. / Freq.	Tune-up limit (dBm)	MPR (dB)
Channel				20450	20525	20600		
Frequency (MHz)				829	836.5	844		
10	QPSK	1	0	22.96	22.90	22.76	24	0
10	QPSK	1	25	22.86	22.84	22.76		
10	QPSK	1	49	22.89	22.79	22.72		
10	QPSK	25	0	21.98	21.95	21.73	23	1
10	QPSK	25	12	22.05	21.96	21.89		
10	QPSK	25	25	21.95	21.84	21.80		
10	QPSK	50	0	22.05	21.92	21.72	23	1
10	16QAM	1	0	22.29	22.25	22.09		
10	16QAM	1	25	22.19	22.18	22.11		
10	16QAM	1	49	22.24	22.06	22.03	22	2
10	16QAM	25	0	21.03	21.04	20.84		
10	16QAM	25	12	21.11	21.03	20.92		
10	16QAM	25	25	21.09	20.97	20.92	22	2
10	16QAM	50	0	21.11	20.98	20.84		
10	64QAM	1	0	21.15	21.18	21.02		
10	64QAM	1	25	21.09	21.10	20.99	22	2
10	64QAM	1	49	21.11	21.00	20.93		
10	64QAM	25	0	19.96	19.99	19.80		
10	64QAM	25	12	20.05	19.99	19.89	21	3
10	64QAM	25	25	20.01	19.95	19.87		
10	64QAM	50	0	20.05	19.95	19.82		



Channel				20425	20525	20625	Tune-up limit (dBm)	MPR (dB)
Frequency (MHz)				826.5	836.5	846.5		
5	QPSK	1	0	22.95	22.88	22.78	24	0
5	QPSK	1	12	22.89	22.82	22.76		
5	QPSK	1	24	22.88	22.82	22.76		
5	QPSK	12	0	21.97	21.90	21.84	23	1
5	QPSK	12	7	21.94	21.90	21.85		
5	QPSK	12	13	21.94	21.89	21.83		
5	QPSK	25	0	21.91	21.86	21.79	23	1
5	16QAM	1	0	22.29	22.25	22.11		
5	16QAM	1	12	22.24	22.18	22.07		
5	16QAM	1	24	22.21	22.15	22.05	22	2
5	16QAM	12	0	21.06	21.02	20.92		
5	16QAM	12	7	21.06	21.03	20.91		
5	16QAM	12	13	21.05	20.99	20.90	22	2
5	16QAM	25	0	21.04	20.99	20.89		
5	64QAM	1	0	21.13	21.06	20.99		
5	64QAM	1	12	21.10	21.02	20.98	22	2
5	64QAM	1	24	21.09	21.00	20.93		
5	64QAM	12	0	19.99	20.00	19.93		
5	64QAM	12	7	20.04	20.04	19.96	21	3
5	64QAM	12	13	19.96	19.98	19.95		
5	64QAM	25	0	19.94	19.95	19.90		
Channel				20415	20525	20635	Tune-up limit (dBm)	MPR (dB)
Frequency (MHz)				825.5	836.5	847.5		
3	QPSK	1	0	22.92	22.85	22.77	24	0
3	QPSK	1	8	22.95	22.94	22.84		
3	QPSK	1	14	22.90	22.83	22.76		
3	QPSK	8	0	21.99	21.89	21.80	23	1
3	QPSK	8	4	21.97	21.94	21.82		
3	QPSK	8	7	21.95	21.86	21.81		
3	QPSK	15	0	21.97	21.91	21.82	23	1
3	16QAM	1	0	22.28	22.20	22.07		
3	16QAM	1	8	22.34	22.32	22.17		
3	16QAM	1	14	22.23	22.14	22.05	22	2
3	16QAM	8	0	21.13	21.02	20.94		
3	16QAM	8	4	21.10	21.07	20.98		
3	16QAM	8	7	21.09	21.00	20.92	22	2
3	16QAM	15	0	21.08	21.00	20.91		
3	64QAM	1	0	21.09	21.05	20.97		
3	64QAM	1	8	21.16	21.15	21.05	22	2
3	64QAM	1	14	21.06	21.00	20.95		
3	64QAM	8	0	20.01	19.97	19.89		
3	64QAM	8	4	20.00	20.00	19.93	21	3
3	64QAM	8	7	19.99	19.96	19.89		
3	64QAM	15	0	19.96	19.91	19.84		



Channel				20407	20525	20643	Tune-up limit (dBm)	MPR (dB)
Frequency (MHz)				824.7	836.5	848.3		
1.4	QPSK	1	0	22.84	22.75	22.68	24	0
1.4	QPSK	1	3	22.92	22.81	22.75		
1.4	QPSK	1	5	22.81	22.73	22.63		
1.4	QPSK	3	0	22.88	22.80	22.72		
1.4	QPSK	3	1	22.92	22.83	22.75		
1.4	QPSK	3	3	22.91	22.81	22.75		
1.4	QPSK	6	0	21.90	21.80	21.71	23	1
1.4	16QAM	1	0	22.17	22.09	21.97	23	1
1.4	16QAM	1	3	22.29	22.14	22.05		
1.4	16QAM	1	5	22.15	22.06	21.97		
1.4	16QAM	3	0	21.97	21.92	21.78		
1.4	16QAM	3	1	22.00	21.92	21.78		
1.4	16QAM	3	3	22.01	21.91	21.81		
1.4	16QAM	6	0	21.05	20.96	20.86	22	2
1.4	64QAM	1	0	21.03	20.94	20.86	22	2
1.4	64QAM	1	3	21.12	21.03	20.99		
1.4	64QAM	1	5	20.99	20.91	20.88		
1.4	64QAM	3	0	21.02	20.97	20.90		
1.4	64QAM	3	1	21.05	21.05	20.96		
1.4	64QAM	3	3	21.05	21.07	20.91		
1.4	64QAM	6	0	19.89	19.81	19.75	21	3



<LTE Band 7>

BW [MHz]	Modulation	RB Size	RB Offset	Power Low Ch. / Freq.	Power Middle Ch. / Freq.	Power High Ch. / Freq.	Tune-up limit (dBm)	MPR (dB)
Channel				20850	21100	21350		
Frequency (MHz)				2510	2535	2560		
20	QPSK	1	0	22.09	22.12	22.35	24	0
20	QPSK	1	49	22.13	22.47	22.67		
20	QPSK	1	99	22.17	22.48	22.88		
20	QPSK	50	0	21.29	21.30	21.60	23	1
20	QPSK	50	24	21.31	21.47	21.71		
20	QPSK	50	50	21.27	21.53	21.87		
20	QPSK	100	0	21.25	21.46	21.64	23	1
20	16QAM	1	0	21.44	21.50	21.71		
20	16QAM	1	49	21.49	21.78	22.00		
20	16QAM	1	99	21.50	21.86	22.14	22	2
20	16QAM	50	0	20.37	20.44	20.72		
20	16QAM	50	24	20.42	20.61	20.80		
20	16QAM	50	50	20.37	20.61	20.94	22	2
20	16QAM	100	0	20.35	20.57	20.72		
20	64QAM	1	0	20.52	20.59	20.62		
20	64QAM	1	49	20.54	20.76	20.89	22	2
20	64QAM	1	99	20.51	20.76	21.08		
20	64QAM	50	0	19.50	19.53	19.71		
20	64QAM	50	24	19.53	19.58	19.80	21	3
20	64QAM	50	50	19.52	19.67	19.93		
20	64QAM	100	0	19.51	19.58	19.76		



Channel				20825	21100	21375	Tune-up limit (dBm)	MPR (dB)
Frequency (MHz)				2507.5	2535	2562.5		
15	QPSK	1	0	22.13	22.20	22.56	24	0
15	QPSK	1	37	22.21	22.48	22.66		
15	QPSK	1	74	22.12	22.47	22.87		
15	QPSK	36	0	21.23	21.40	21.75	23	1
15	QPSK	36	20	21.30	21.53	21.79		
15	QPSK	36	39	21.24	21.49	21.83		
15	QPSK	75	0	21.26	21.48	21.76	23	1
15	16QAM	1	0	21.51	21.52	21.94		
15	16QAM	1	37	21.56	21.81	21.99		
15	16QAM	1	74	21.49	21.79	22.16	22	2
15	16QAM	36	0	20.31	20.55	20.82		
15	16QAM	36	20	20.38	20.61	20.86		
15	16QAM	36	39	20.33	20.63	20.89	22	2
15	16QAM	75	0	20.34	20.55	20.83		
15	64QAM	1	0	20.55	20.57	20.84		
15	64QAM	1	37	20.58	20.73	20.92	22	2
15	64QAM	1	74	20.56	20.68	21.11		
15	64QAM	36	0	19.53	19.56	19.83		
15	64QAM	36	20	19.54	19.62	19.93	21	3
15	64QAM	36	39	19.54	19.66	19.92		
15	64QAM	75	0	19.51	19.55	19.84		
Channel				20800	21100	21400	Tune-up limit (dBm)	MPR (dB)
Frequency (MHz)				2505	2535	2565		
10	QPSK	1	0	22.13	22.27	22.64	24	0
10	QPSK	1	25	22.16	22.44	22.71		
10	QPSK	1	49	22.10	22.39	22.86		
10	QPSK	25	0	21.24	21.40	21.76	23	1
10	QPSK	25	12	21.31	21.48	21.80		
10	QPSK	25	25	21.22	21.50	21.84		
10	QPSK	50	0	21.29	21.48	21.88	23	1
10	16QAM	1	0	21.46	21.57	21.91		
10	16QAM	1	25	21.49	21.74	22.01		
10	16QAM	1	49	21.48	21.69	22.11	22	2
10	16QAM	25	0	20.31	20.48	20.84		
10	16QAM	25	12	20.40	20.56	20.87		
10	16QAM	25	25	20.31	20.57	20.89	22	2
10	16QAM	50	0	20.39	20.57	20.92		
10	64QAM	1	0	20.53	20.59	20.84		
10	64QAM	1	25	20.53	20.70	20.95	22	2
10	64QAM	1	49	20.51	20.64	21.04		
10	64QAM	25	0	19.51	19.55	19.81		
10	64QAM	25	12	19.53	19.55	19.85	21	3
10	64QAM	25	25	19.50	19.57	19.94		
10	64QAM	50	0	19.51	19.56	19.96		



Channel				20775	21100	21425	Tune-up limit (dBm)	MPR (dB)
Frequency (MHz)				2502.5	2535	2567.5		
5	QPSK	1	0	22.14	22.30	22.70	24	0
5	QPSK	1	12	22.20	22.45	22.82		
5	QPSK	1	24	22.16	22.43	22.85		
5	QPSK	12	0	21.31	21.41	21.79	23	1
5	QPSK	12	7	21.33	21.48	21.88		
5	QPSK	12	13	21.27	21.46	21.90		
5	QPSK	25	0	21.25	21.43	21.84		
5	16QAM	1	0	21.47	21.60	22.01	23	1
5	16QAM	1	12	21.59	21.78	22.11		
5	16QAM	1	24	21.46	21.81	22.12		
5	16QAM	12	0	20.38	20.52	20.87	22	2
5	16QAM	12	7	20.40	20.56	20.94		
5	16QAM	12	13	20.36	20.55	20.97		
5	16QAM	25	0	20.34	20.51	20.88		
5	64QAM	1	0	20.53	20.58	20.94	22	2
5	64QAM	1	12	20.56	20.71	21.03		
5	64QAM	1	24	20.54	20.72	21.07		
5	64QAM	12	0	19.51	19.56	19.91	21	3
5	64QAM	12	7	19.53	19.60	19.98		
5	64QAM	12	13	19.52	19.63	19.99		
5	64QAM	25	0	19.51	19.57	19.94		



<Maximum Average RF Power (Proximity Sensor On)>

<LTE Band 4>

BW [MHz]	Modulation	RB Size	RB Offset	Power Low Ch. / Freq.	Power Middle Ch. / Freq.	Power High Ch. / Freq.	Tune-up limit (dBm)	MPR (dB)
Channel				20050	20175	20300		
Frequency (MHz)				1720	1732.5	1745		
20	QPSK	1	0	19.53	19.68	19.87	20.5	0
20	QPSK	1	49	19.38	19.62	19.65		
20	QPSK	1	99	19.51	19.64	19.41		
20	QPSK	50	0	18.53	18.73	18.82	19.5	1
20	QPSK	50	24	18.48	18.69	18.77		
20	QPSK	50	50	18.49	18.66	18.60		
20	QPSK	100	0	18.50	18.69	18.72	19.5	1
20	16QAM	1	0	18.94	19.05	19.30		
20	16QAM	1	49	18.82	19.03	19.09		
20	16QAM	1	99	18.91	18.99	18.85	19.5	1
20	16QAM	50	0	17.59	17.80	17.93		
20	16QAM	50	24	17.58	17.81	17.88		
20	16QAM	50	50	17.62	17.78	17.72	18.5	2
20	16QAM	100	0	17.59	17.82	17.83		
20	16QAM	100	0	17.59	17.82	17.83		
20	64QAM	1	0	17.82	18.01	18.19	18.5	2
20	64QAM	1	49	17.78	17.98	17.95		
20	64QAM	1	99	17.88	17.90	17.69		
20	64QAM	50	0	16.63	16.82	16.94	17.5	3
20	64QAM	50	24	16.61	16.84	16.87		
20	64QAM	50	50	16.64	16.79	16.73		
20	64QAM	100	0	16.64	16.81	16.82	17.5	3



Channel				20025	20175	20325	Tune-up limit (dBm)	MPR (dB)
Frequency (MHz)				1717.5	1732.5	1747.5		
15	QPSK	1	0	19.50	19.67	19.85	20.5	0
15	QPSK	1	37	19.35	19.64	19.63		
15	QPSK	1	74	19.46	19.66	19.50		
15	QPSK	36	0	18.48	18.73	18.81	19.5	1
15	QPSK	36	20	18.45	18.73	18.74		
15	QPSK	36	39	18.50	18.70	18.62		
15	QPSK	75	0	18.49	18.70	18.71	19.5	1
15	16QAM	1	0	18.96	19.09	19.29		
15	16QAM	1	37	18.78	19.02	19.02		
15	16QAM	1	74	18.92	19.08	18.89	18.5	2
15	16QAM	36	0	17.62	17.82	17.92		
15	16QAM	36	20	17.57	17.82	17.85		
15	16QAM	36	39	17.58	17.82	17.73	18.5	2
15	16QAM	75	0	17.57	17.80	17.81		
15	64QAM	1	0	17.86	18.05	18.18		
15	64QAM	1	37	17.67	17.95	17.91	18.5	2
15	64QAM	1	74	17.78	17.97	17.75		
15	64QAM	36	0	16.64	16.86	16.95		
15	64QAM	36	20	16.59	16.84	16.89	17.5	3
15	64QAM	36	39	16.60	16.84	16.78		
15	64QAM	75	0	16.57	16.82	16.78		



Channel				20000	20175	20350	Tune-up limit (dBm)	MPR (dB)
Frequency (MHz)				1715	1732.5	1750		
10	QPSK	1	0	19.31	19.63	19.74	20.5	0
10	QPSK	1	25	19.22	19.61	19.59		
10	QPSK	1	49	19.25	19.62	19.45		
10	QPSK	25	0	18.33	18.70	18.71	19.5	1
10	QPSK	25	12	18.33	18.68	18.63		
10	QPSK	25	25	18.29	18.66	18.56		
10	QPSK	50	0	18.35	18.67	18.67		
10	16QAM	1	0	18.76	19.07	19.14	19.5	1
10	16QAM	1	25	18.65	19.04	19.01		
10	16QAM	1	49	18.66	19.09	18.85		
10	16QAM	25	0	17.43	17.81	17.84	18.5	2
10	16QAM	25	12	17.42	17.78	17.75		
10	16QAM	25	25	17.39	17.78	17.66		
10	16QAM	50	0	17.41	17.79	17.76		
10	64QAM	1	0	17.67	17.97	18.05	18.5	2
10	64QAM	1	25	17.57	17.95	17.92		
10	64QAM	1	49	17.60	17.97	17.75		
10	64QAM	25	0	16.43	16.82	16.85	17.5	3
10	64QAM	25	12	16.45	16.84	16.77		
10	64QAM	25	25	16.40	16.79	16.67		
10	64QAM	50	0	16.43	16.80	16.79		
Channel				19975	20175	20375	Tune-up limit (dBm)	MPR (dB)
Frequency (MHz)				1712.5	1732.5	1752.5		
5	QPSK	1	0	19.30	19.62	19.59	20.5	0
5	QPSK	1	12	19.23	19.60	19.52		
5	QPSK	1	24	19.22	19.64	19.47		
5	QPSK	12	0	18.30	18.67	18.61	19.5	1
5	QPSK	12	7	18.30	18.73	18.64		
5	QPSK	12	13	18.31	18.70	18.59		
5	QPSK	25	0	18.28	18.68	18.58		
5	16QAM	1	0	18.72	19.00	19.01	19.5	1
5	16QAM	1	12	18.64	19.02	18.87		
5	16QAM	1	24	18.63	19.04	18.86		
5	16QAM	12	0	17.43	17.79	17.73	18.5	2
5	16QAM	12	7	17.44	17.83	17.72		
5	16QAM	12	13	17.42	17.81	17.68		
5	16QAM	25	0	17.40	17.80	17.66		
5	64QAM	1	0	17.64	17.96	17.96	18.5	2
5	64QAM	1	12	17.52	17.95	17.85		
5	64QAM	1	24	17.57	17.96	17.79		
5	64QAM	12	0	16.47	16.84	16.79	17.5	3
5	64QAM	12	7	16.50	16.89	16.76		
5	64QAM	12	13	16.46	16.87	16.70		
5	64QAM	25	0	16.40	16.81	16.68		



Channel				19965	20175	20385	Tune-up limit (dBm)	MPR (dB)
Frequency (MHz)				1711.5	1732.5	1753.5		
3	QPSK	1	0	19.32	19.62	19.54	20.5	0
3	QPSK	1	8	19.40	19.72	19.61		
3	QPSK	1	14	19.22	19.62	19.48		
3	QPSK	8	0	18.31	18.68	18.62	19.5	1
3	QPSK	8	4	18.29	18.72	18.61		
3	QPSK	8	7	18.27	18.70	18.54		
3	QPSK	15	0	18.25	18.66	18.54		
3	16QAM	1	0	18.69	19.02	18.96	19.5	1
3	16QAM	1	8	18.73	19.14	19.02		
3	16QAM	1	14	18.62	19.05	18.85		
3	16QAM	8	0	17.49	17.83	17.77	18.5	2
3	16QAM	8	4	17.48	17.89	17.77		
3	16QAM	8	7	17.47	17.87	17.70		
3	16QAM	15	0	17.41	17.82	17.66		
3	64QAM	1	0	17.56	17.93	17.84	18.5	2
3	64QAM	1	8	17.69	18.05	17.94		
3	64QAM	1	14	17.56	17.97	17.78		
3	64QAM	8	0	16.50	16.82	16.73	17.5	3
3	64QAM	8	4	16.50	16.88	16.74		
3	64QAM	8	7	16.46	16.85	16.71		
3	64QAM	15	0	16.40	16.81	16.68		
Channel				19957	20175	20393	Tune-up limit (dBm)	MPR (dB)
Frequency (MHz)				1710.7	1732.5	1754.3		
1.4	QPSK	1	0	19.16	19.57	19.43	20.5	0
1.4	QPSK	1	3	19.24	19.62	19.49		
1.4	QPSK	1	5	19.13	19.54	19.43		
1.4	QPSK	3	0	19.19	19.61	19.46		
1.4	QPSK	3	1	19.23	19.63	19.49		
1.4	QPSK	3	3	19.23	19.64	19.51		
1.4	QPSK	6	0	18.23	18.62	18.47	19.5	1
1.4	16QAM	1	0	18.62	18.95	18.81	19.5	1
1.4	16QAM	1	3	18.68	19.04	18.89		
1.4	16QAM	1	5	18.57	18.99	18.83		
1.4	16QAM	3	0	18.37	18.73	18.59		
1.4	16QAM	3	1	18.38	18.77	18.63		
1.4	16QAM	3	3	18.36	18.76	18.65		
1.4	16QAM	6	0	17.38	17.81	17.65	18.5	2
1.4	64QAM	1	0	17.51	17.88	17.73	18.5	2
1.4	64QAM	1	3	17.58	17.91	17.81		
1.4	64QAM	1	5	17.49	17.85	17.73		
1.4	64QAM	3	0	17.48	17.84	17.68		
1.4	64QAM	3	1	17.52	17.91	17.73		
1.4	64QAM	3	3	17.53	17.90	17.72		
1.4	64QAM	6	0	16.34	16.74	16.59	17.5	3



<LTE Band 7>

BW [MHz]	Modulation	RB Size	RB Offset	Power Low Ch. / Freq.	Power Middle Ch. / Freq.	Power High Ch. / Freq.	Tune-up limit (dBm)	MPR (dB)
Channel				20850	21100	21350		
Frequency (MHz)				2510	2535	2560		
20	QPSK	1	0	19.45	19.45	19.40	20.5	0
20	QPSK	1	49	19.42	19.61	19.62		
20	QPSK	1	99	19.51	19.69	19.84		
20	QPSK	50	0	18.62	18.60	18.59	19.5	1
20	QPSK	50	24	18.69	18.68	18.65		
20	QPSK	50	50	18.70	18.70	18.76		
20	QPSK	100	0	18.66	18.69	18.63	19.5	1
20	16QAM	1	0	18.87	18.77	18.75		
20	16QAM	1	49	18.95	19.00	18.92		
20	16QAM	1	99	18.79	18.91	19.04	18.5	2
20	16QAM	50	0	17.79	17.67	17.66		
20	16QAM	50	24	17.77	17.82	17.72		
20	16QAM	50	50	17.70	17.80	17.84	18.5	2
20	16QAM	100	0	17.75	17.75	17.68		
20	64QAM	1	0	17.70	17.75	17.66		
20	64QAM	1	49	17.79	17.97	17.89	18.5	2
20	64QAM	1	99	17.65	17.89	17.97		
20	64QAM	50	0	16.82	16.68	16.72		
20	64QAM	50	24	16.79	16.80	16.77	17.5	3
20	64QAM	50	50	16.73	16.82	16.88		
20	64QAM	100	0	16.73	16.81	16.75		



Channel				20825	21100	21375	Tune-up limit (dBm)	MPR (dB)
Frequency (MHz)				2507.5	2535	2562.5		
15	QPSK	1	0	19.59	19.51	19.64	20.5	0
15	QPSK	1	37	19.67	19.78	19.64		
15	QPSK	1	74	19.53	19.65	19.80		
15	QPSK	36	0	18.68	18.72	18.75	19.5	1
15	QPSK	36	20	18.76	18.81	18.81		
15	QPSK	36	39	18.72	18.82	18.83		
15	QPSK	75	0	18.72	18.76	18.76	19.5	1
15	16QAM	1	0	18.98	18.91	18.98		
15	16QAM	1	37	19.02	19.11	19.04		
15	16QAM	1	74	18.87	19.08	19.14	18.5	2
15	16QAM	36	0	17.75	17.85	17.86		
15	16QAM	36	20	17.82	17.87	17.88		
15	16QAM	36	39	17.83	17.87	17.89	18.5	2
15	16QAM	75	0	17.78	17.82	17.88		
15	64QAM	1	0	17.87	17.82	17.92		
15	64QAM	1	37	17.99	18.03	17.93	18.5	2
15	64QAM	1	74	17.85	17.96	18.07		
15	64QAM	36	0	16.83	16.88	16.90		
15	64QAM	36	20	16.91	16.88	16.91	17.5	3
15	64QAM	36	39	16.83	16.87	16.90		
15	64QAM	75	0	16.84	16.84	16.86		



Channel				20800	21100	21400	Tune-up limit (dBm)	MPR (dB)
Frequency (MHz)				2505	2535	2565		
10	QPSK	1	0	19.62	19.59	19.59	20.5	0
10	QPSK	1	25	19.62	19.73	19.67		
10	QPSK	1	49	19.57	19.62	19.77		
10	QPSK	25	0	18.74	18.72	18.77	19.5	1
10	QPSK	25	12	18.84	18.76	18.75		
10	QPSK	25	25	18.70	18.78	18.80		
10	QPSK	50	0	18.76	18.78	18.84		
10	16QAM	1	0	18.97	18.98	18.96	19.5	1
10	16QAM	1	25	19.00	19.08	19.08		
10	16QAM	1	49	18.92	18.99	19.20		
10	16QAM	25	0	17.81	17.85	17.87	18.5	2
10	16QAM	25	12	17.92	17.83	17.89		
10	16QAM	25	25	17.80	17.85	17.88		
10	16QAM	50	0	17.84	17.86	17.92		
10	64QAM	1	0	17.91	17.91	17.82	18.5	2
10	64QAM	1	25	17.94	18.00	17.90		
10	64QAM	1	49	17.89	17.95	18.09		
10	64QAM	25	0	16.87	16.83	16.85	17.5	3
10	64QAM	25	12	16.91	16.88	16.88		
10	64QAM	25	25	16.85	16.84	16.92		
10	64QAM	50	0	16.90	16.83	16.92		
Channel				20775	21100	21425	Tune-up limit (dBm)	MPR (dB)
Frequency (MHz)				2502.5	2535	2567.5		
5	QPSK	1	0	19.63	19.61	19.68	20.5	0
5	QPSK	1	12	19.69	19.72	19.75		
5	QPSK	1	24	19.64	19.74	19.74		
5	QPSK	12	0	18.77	18.74	18.77	19.5	1
5	QPSK	12	7	18.81	18.78	18.87		
5	QPSK	12	13	18.74	18.77	18.85		
5	QPSK	25	0	18.73	18.72	18.81		
5	16QAM	1	0	19.02	19.00	19.01	19.5	1
5	16QAM	1	12	19.09	19.11	19.16		
5	16QAM	1	24	18.99	19.09	19.16		
5	16QAM	12	0	17.87	17.82	17.85	18.5	2
5	16QAM	12	7	17.88	17.86	17.95		
5	16QAM	12	13	17.86	17.88	17.93		
5	16QAM	25	0	17.83	17.80	17.88		
5	64QAM	1	0	17.94	17.88	17.97	18.5	2
5	64QAM	1	12	18.00	18.02	18.03		
5	64QAM	1	24	17.93	18.01	18.02		
5	64QAM	12	0	16.92	16.87	16.92	17.5	3
5	64QAM	12	7	16.95	16.91	16.96		
5	64QAM	12	13	16.87	16.90	17.01		
5	64QAM	25	0	16.86	16.86	16.91		

<TDD LTE SAR Measurement>

TDD LTE configuration setup for SAR measurement

SAR was tested with a fixed periodic duty factor according to the highest transmission duty factor implemented for the device and supported by 3GPP.

- a. 3GPP TS 36.211 section 4.2 for Type 2 Frame Structure and Table 4.2-2 for uplink-downlink configurations
- b. "special subframe S" contains both uplink and downlink transmissions, it has been taken into consideration to determine the transmission duty factor according to the worst case uplink and downlink cyclic prefix requirements for UpPTS
- c. Establishing connections with base station simulators ensure a consistent means for testing SAR and recommended for evaluating SAR. The Anritsu MT8820C (firmware: #22.52#004) was used for LTE output power measurements and SAR testing.

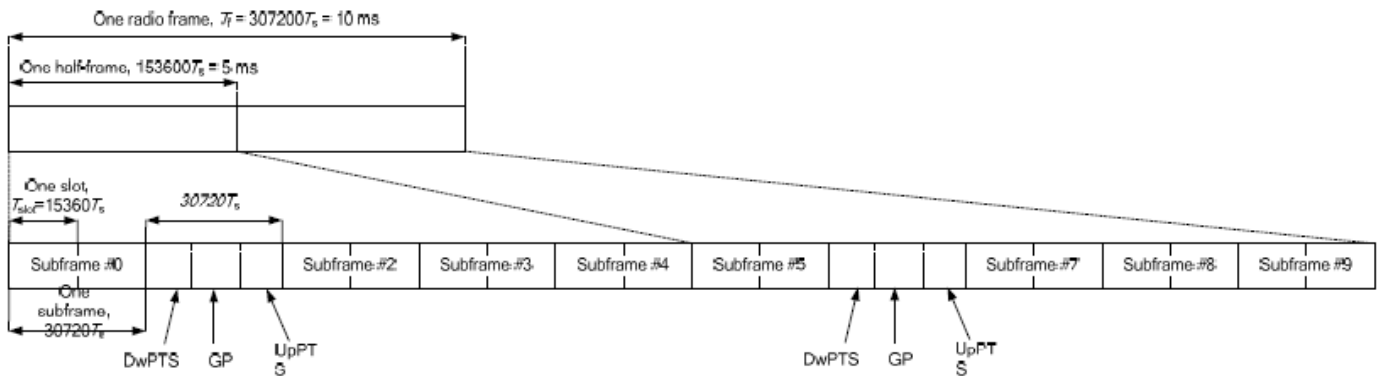

Figure 4.2-1: Frame structure type 2 (for 5 ms switch-point periodicity).

Table 4.2-2: Uplink-downlink configurations.

Uplink-downlink configuration	Downlink-to-Uplink Switch-point periodicity	Subframe number									
		0	1	2	3	4	5	6	7	8	9
0	5 ms	D	S	U	U	U	D	S	U	U	U
1	5 ms	D	S	U	U	D	D	S	U	U	D
2	5 ms	D	S	U	D	D	D	S	U	D	D
3	10 ms	D	S	U	U	U	D	D	D	D	D
4	10 ms	D	S	U	U	D	D	D	D	D	D
5	10 ms	D	S	U	D	D	D	D	D	D	D
6	5 ms	D	S	U	U	U	D	S	U	U	D

Table 4.2-1: Configuration of special subframe (lengths of DwPTS/GP/UpPTS).

Special subframe configuration	Normal cyclic prefix in downlink			Extended cyclic prefix in downlink		
	DwPTS	UpPTS		DwPTS	UpPTS	
		Normal cyclic prefix in uplink	Extended cyclic prefix in uplink		Normal cyclic prefix in uplink	Extended cyclic prefix in uplink
0	6592 · Ts	2192 · Ts	2560 · Ts	7680 · Ts	2192 · Ts	2560 · Ts
1	19760 · Ts			20480 · Ts		
2	21952 · Ts			23040 · Ts		
3	24144 · Ts			25600 · Ts		
4	26336 · Ts			7680 · Ts	4384 · Ts	5120 · Ts
5	6592 · Ts	4384 · Ts	5120 · Ts	20480 · Ts		
6	19760 · Ts			23040 · Ts		
7	21952 · Ts			12800 · Ts		
8	24144 · Ts			-	-	-
9	13168 · Ts			-	-	-

Special subframe (30720·T_s): Normal cyclic prefix in downlink (UpPTS)			
	Special subframe configuration	Normal cyclic prefix in uplink	Extended cyclic prefix in uplink
Uplink duty factor in one special subframe	0~4	7.13%	8.33%
	5~9	14.3%	16.7%

Special subframe(30720·T_s): Extended cyclic prefix in downlink (UpPTS)			
	Special subframe configuration	Normal cyclic prefix in uplink	Extended cyclic prefix in uplink
Uplink duty factor in one special subframe	0~3	7.13%	8.33%
	4~7	14.3%	16.7%

The highest duty factor is resulted from:

- i. Uplink-downlink configuration: 0. In a half-frame consisted of 5 subframes, uplink operation is in 3 uplink subframes and 1 special subframe.
- ii. special subframe configuration: 5-9 for normal cyclic prefix in downlink, 4-7 for extended cyclic prefix in downlink
- iii. for special subframe with extended cyclic prefix in uplink, the total uplink duty factor in one half-frame is: $(3+0.167)/5 = 63.3\%$
- iv. for special subframe with normal cyclic prefix in uplink, the total uplink duty factor in one half-frame is: $(3+0.143)/5 = 62.9\%$
- v. For TDD LTE SAR measurement, the duty cycle 1:1.59 (62.9 %) was used perform testing and considering the theoretical duty cycle of 63.3% for extended cyclic prefix in the uplink, and the theoretical duty cycle of 62.9% for normal cyclic prefix in uplink, a scaling factor of extended cyclic prefix $63.3\%/62.9\% = 1.006$ is applied to scale-up the measured SAR result. The scaled TDD LTE SAR = measured SAR (W/kg)* Tune-up Scaling Factor* scaling factor for extended cyclic prefix.



<Maximum Average RF Power (Proximity Sensor Off)>

<LTE Band 38>

BW [MHz]	Modulation	RB Size	RB Offset	Power Low Ch. / Freq.	Power Middle Ch. / Freq.	Power High Ch. / Freq.	Tune-up limit (dBm)	MPR (dB)
Channel				37850	38000	38150		
Frequency (MHz)				2580	2595	2610		
20	QPSK	1	0	22.72	22.66	22.68	24.3	0
20	QPSK	1	49	22.90	22.79	22.75		
20	QPSK	1	99	22.77	22.71	22.63		
20	QPSK	50	0	21.85	21.81	21.75	23.3	1
20	QPSK	50	24	21.81	21.80	21.73		
20	QPSK	50	50	21.86	21.81	21.78		
20	QPSK	100	0	21.81	21.79	21.73	23.3	1
20	16QAM	1	0	21.87	21.82	21.80		
20	16QAM	1	49	22.03	21.92	21.85		
20	16QAM	1	99	21.91	21.84	21.72	22.3	2
20	16QAM	50	0	20.98	20.90	20.87		
20	16QAM	50	24	20.95	20.96	20.88		
20	16QAM	50	50	20.95	20.90	20.81	22.3	2
20	16QAM	100	0	20.90	20.89	20.84		
20	64QAM	1	0	20.64	20.56	20.57		
20	64QAM	1	49	20.78	20.69	20.58	22.3	2
20	64QAM	1	99	20.68	20.59	20.52		
20	64QAM	50	0	19.97	19.87	19.84		
20	64QAM	50	24	19.95	19.92	19.87	21.3	3
20	64QAM	50	50	19.95	19.90	19.83		
20	64QAM	100	0	19.87	19.88	19.83		



Channel				37825	38000	38175	Tune-up limit (dBm)	MPR (dB)
Frequency (MHz)				2577.5	2595	2612.5		
15	QPSK	1	0	22.76	22.70	22.71	24.3	0
15	QPSK	1	37	22.88	22.81	22.73		
15	QPSK	1	74	22.80	22.77	22.68		
15	QPSK	36	0	21.83	21.79	21.72	23.3	1
15	QPSK	36	20	21.92	21.84	21.76		
15	QPSK	36	39	21.82	21.80	21.73		
15	QPSK	75	0	21.80	21.78	21.73	23.3	1
15	16QAM	1	0	21.94	21.87	21.81		
15	16QAM	1	37	22.04	21.92	21.83		
15	16QAM	1	74	21.93	21.87	21.75	22.3	2
15	16QAM	36	0	20.92	20.84	20.78		
15	16QAM	36	20	21.00	20.89	20.81		
15	16QAM	36	39	20.89	20.85	20.78	21.3	3
15	16QAM	75	0	20.89	20.89	20.80		
15	64QAM	1	0	20.68	20.61	20.58		
15	64QAM	1	37	20.74	20.67	20.56	22.3	2
15	64QAM	1	74	20.70	20.63	20.50		
15	64QAM	36	0	19.95	19.88	19.80		
15	64QAM	36	20	20.03	19.91	19.84	21.3	3
15	64QAM	36	39	19.91	19.90	19.79		
15	64QAM	75	0	19.91	19.90	19.81		
Channel				37800	38000	38200	Tune-up limit (dBm)	MPR (dB)
Frequency (MHz)				2575	2595	2615		
10	QPSK	1	0	22.77	22.72	22.69	24.3	0
10	QPSK	1	25	22.85	22.82	22.70		
10	QPSK	1	49	22.89	22.76	22.65		
10	QPSK	25	0	21.82	21.77	21.74	23.3	1
10	QPSK	25	12	21.90	21.82	21.71		
10	QPSK	25	25	21.87	21.77	21.69		
10	QPSK	50	0	21.85	21.82	21.72	23.3	1
10	16QAM	1	0	21.90	21.88	21.82		
10	16QAM	1	25	21.93	21.92	21.81		
10	16QAM	1	49	21.98	21.86	21.74	22.3	2
10	16QAM	25	0	20.95	20.89	20.82		
10	16QAM	25	12	21.01	20.93	20.87		
10	16QAM	25	25	20.99	20.90	20.82	22.3	2
10	16QAM	50	0	20.98	20.91	20.85		
10	64QAM	1	0	20.66	20.62	20.57		
10	64QAM	1	25	20.75	20.66	20.58	21.3	3
10	64QAM	1	49	20.74	20.60	20.52		
10	64QAM	25	0	19.99	19.91	19.85		
10	64QAM	25	12	20.04	19.98	19.87	21.3	3
10	64QAM	25	25	20.02	19.92	19.84		
10	64QAM	50	0	19.98	19.92	19.82		



Channel				37775	38000	38225	Tune-up limit (dBm)	MPR (dB)
Frequency (MHz)				2572.5	2595	2617.5		
5	QPSK	1	0	22.78	22.75	22.70	24.3	0
5	QPSK	1	12	22.81	22.78	22.70		
5	QPSK	1	24	22.78	22.73	22.64		
5	QPSK	12	0	21.84	21.79	21.70	23.3	1
5	QPSK	12	7	21.90	21.82	21.74		
5	QPSK	12	13	21.88	21.81	21.73		
5	QPSK	25	0	21.83	21.76	21.70		
5	16QAM	1	0	21.90	21.86	21.77	23.3	1
5	16QAM	1	12	21.94	21.89	21.79		
5	16QAM	1	24	21.96	21.89	21.78		
5	16QAM	12	0	20.88	20.83	20.74	22.3	2
5	16QAM	12	7	20.93	20.88	20.81		
5	16QAM	12	13	20.90	20.87	20.78		
5	16QAM	25	0	20.95	20.90	20.80		
5	64QAM	1	0	20.65	20.64	20.56	22.3	2
5	64QAM	1	12	20.67	20.67	20.55		
5	64QAM	1	24	20.73	20.68	20.54		
5	64QAM	12	0	19.96	19.90	19.81	21.3	3
5	64QAM	12	7	19.98	19.92	19.83		
5	64QAM	12	13	19.96	19.90	19.80		
5	64QAM	25	0	19.98	19.90	19.83		



<Maximum Average RF Power (Proximity Sensor On)>

<LTE Band 38>

BW [MHz]	Modulation	RB Size	RB Offset	Power Low Ch. / Freq.	Power Middle Ch. / Freq.	Power High Ch. / Freq.	Tune-up limit (dBm)	MPR (dB)
Channel				37850	38000	38150		
Frequency (MHz)				2580	2595	2610		
20	QPSK	1	0	20.68	20.45	20.36	22	0
20	QPSK	1	49	20.75	20.48	20.37		
20	QPSK	1	99	20.59	20.38	20.27		
20	QPSK	50	0	19.71	19.52	19.42	21	1
20	QPSK	50	24	19.75	19.50	19.46		
20	QPSK	50	50	19.76	19.56	19.47		
20	QPSK	100	0	19.71	19.51	19.42	21	1
20	16QAM	1	0	19.01	19.60	19.54		
20	16QAM	1	49	19.50	19.62	19.54		
20	16QAM	1	99	19.42	19.50	19.40	20	2
20	16QAM	50	0	18.73	18.64	18.56		
20	16QAM	50	24	18.81	18.64	18.55		
20	16QAM	50	50	18.75	18.60	18.49	20	2
20	16QAM	100	0	18.76	18.62	18.53		
20	64QAM	1	0	18.59	18.31	18.28		
20	64QAM	1	49	18.65	18.14	18.28	20	2
20	64QAM	1	99	18.44	18.32	18.15		
20	64QAM	50	0	17.88	17.89	17.54		
20	64QAM	50	24	17.83	17.81	17.59	19	3
20	64QAM	50	50	17.76	17.61	17.50		
20	64QAM	100	0	17.77	17.63	17.54		



Channel				37825	38000	38175	Tune-up limit (dBm)	MPR (dB)
Frequency (MHz)				2577.5	2595	2612.5		
15	QPSK	1	0	20.58	20.48	20.56	22	0
15	QPSK	1	37	20.65	20.58	20.60		
15	QPSK	1	74	20.55	20.59	20.58		
15	QPSK	36	0	19.66	19.56	19.60	21	1
15	QPSK	36	20	19.73	19.62	19.69		
15	QPSK	36	39	19.60	19.64	19.64		
15	QPSK	75	0	19.55	19.62	19.65		
15	16QAM	1	0	19.70	19.62	19.66	21	1
15	16QAM	1	37	19.82	19.74	19.73		
15	16QAM	1	74	19.70	19.69	19.71		
15	16QAM	36	0	18.68	18.65	18.67	20	2
15	16QAM	36	20	18.76	18.72	18.71		
15	16QAM	36	39	18.65	18.68	18.72		
15	16QAM	75	0	18.68	18.67	18.76		
15	64QAM	1	0	18.46	18.36	18.42	20	2
15	64QAM	1	37	18.54	18.45	18.50		
15	64QAM	1	74	18.45	18.46	18.44		
15	64QAM	36	0	17.70	17.65	17.70	19	3
15	64QAM	36	20	17.78	17.72	17.72		
15	64QAM	36	39	17.70	17.69	17.69		
15	64QAM	75	0	17.66	17.72	17.72		
Channel				37800	38000	38200	Tune-up limit (dBm)	MPR (dB)
Frequency (MHz)				2575	2595	2615		
10	QPSK	1	0	20.52	20.49	20.57	22	0
10	QPSK	1	25	20.59	20.56	20.62		
10	QPSK	1	49	20.62	20.57	20.60		
10	QPSK	25	0	19.59	19.56	19.64	21	1
10	QPSK	25	12	19.68	19.65	19.68		
10	QPSK	25	25	19.63	19.57	19.66		
10	QPSK	50	0	19.65	19.61	19.64		
10	16QAM	1	0	19.71	19.63	19.69	21	1
10	16QAM	1	25	19.76	19.72	19.72		
10	16QAM	1	49	19.72	19.64	19.69		
10	16QAM	25	0	18.73	18.70	18.73	20	2
10	16QAM	25	12	18.76	18.72	18.76		
10	16QAM	25	25	18.78	18.74	18.75		
10	16QAM	50	0	18.72	18.70	18.74		
10	64QAM	1	0	18.42	18.42	18.47	20	2
10	64QAM	1	25	18.53	18.49	18.53		
10	64QAM	1	49	18.50	18.44	18.46		
10	64QAM	25	0	17.73	17.70	17.75	19	3
10	64QAM	25	12	17.81	17.78	17.79		
10	64QAM	25	25	17.80	17.74	17.77		
10	64QAM	50	0	17.78	17.73	17.75		



Channel				37775	38000	38225	Tune-up limit (dBm)	MPR (dB)
Frequency (MHz)				2572.5	2595	2617.5		
5	QPSK	1	0	20.55	20.52	20.59	22	0
5	QPSK	1	12	20.53	20.56	20.58		
5	QPSK	1	24	20.55	20.48	20.59		
5	QPSK	12	0	19.58	19.60	19.65	21	1
5	QPSK	12	7	19.66	19.64	19.68		
5	QPSK	12	13	19.63	19.60	19.69		
5	QPSK	25	0	19.60	19.59	19.60		
5	16QAM	1	0	19.69	19.65	19.69	21	1
5	16QAM	1	12	19.70	19.66	19.74		
5	16QAM	1	24	19.74	19.71	19.75		
5	16QAM	12	0	18.67	18.65	18.68	20	2
5	16QAM	12	7	18.69	18.69	18.70		
5	16QAM	12	13	18.66	18.68	18.68		
5	16QAM	25	0	18.71	18.68	18.73		
5	64QAM	1	0	18.42	18.43	18.44	20	2
5	64QAM	1	12	18.47	18.46	18.48		
5	64QAM	1	24	18.49	18.44	18.47		
5	64QAM	12	0	17.69	17.68	17.70	19	3
5	64QAM	12	7	17.77	17.74	17.80		
5	64QAM	12	13	17.76	17.70	17.78		
5	64QAM	25	0	17.75	17.76	17.78		

<LTE Carrier Aggregation>

General Note:

This device supports Carrier Aggregation on downlink for intra band, on uplink for intra band. For the device supports bands and bandwidths and configurations are provided as follow table was according to 3GPP.

<Intra-Band Carrier Combination> (Contiguous)

E-UTRA CA configuration / Bandwidth combination set							
E-UTRA CA configuration	Uplink CA configurations	Component carriers in order of increasing carrier frequency				Maximum aggregated bandwidth [MHz]	Bandwidth combination set
		Channel bandwidths for carrier [MHz]	Channel bandwidths for carrier [MHz]	Channel bandwidths for carrier [MHz]	Channel bandwidths for carrier [MHz]		
CA_7C	CA_7C	15	15			40	0
		20	20				
		10	20			40	1
		15	15, 20				
		20	10, 15, 20				
		15	10, 15				
CA_38C	CA_38C	20	15, 20			40	2
		15	15			40	0
		20	20				



<DL CA power measurement>

General Note:

- 1. This device supports Carrier Aggregation on downlink for inter and intra band. For the device supports bands and bandwidths and configurations are provided as follow table was according to 3GPP.
- 2. In applying the existing power measurement procedures of KDB 941225 D05A for DL CA SAR test exclusion, only the subset with the largest number of combinations of frequency bands and CCs in each row need combination, and for this device that all the configurations were choose to power measurement.

Index	2CC	Restriction	Completely Covered by Measurement Superset
2CC #1	CA_7C		No
2CC #2	CA_38C		No

LTE Carrier Aggregation Conducted Power (Downlink)

General Note:

- i. According to KDB941225 D05A v01r02, Uplink maximum output power measurement with downlink carrier aggregation active should be measured, using the highest output channel measured without downlink carrier aggregation, to confirm that uplink maximum output power with downlink carrier aggregation active remains within the specified tune-up tolerance limits and not more than ¼ dB higher than the maximum output measured without downlink carrier aggregation active.
- ii. Uplink maximum output power with downlink carrier aggregation active does not show more than ¼ dB higher than the maximum output power without downlink carrier aggregation active, therefore SAR evaluation with downlink carrier aggregation active can be excluded.
- iii. The device supports downlink carrier aggregation only. Uplink carrier aggregation is not supported. For power measurement were control and acknowledge data is sent on uplink channels that operate identical to specifications when downlink carrier aggregation is inactive.
- iv. Selected highest measured power when downlink carrier aggregation is inactive for conducted power comparison with downlink carrier aggregation is active, to confirm that when downlink carrier aggregation is active uplink maximum output power remains within the specified tune-up tolerance limits and not more than ¼ dB higher than the maximum output power measured when downlink carrier aggregation inactive.
- v. For inter-band CA, the SCC selected highest bandwidth and near the middle of its transmission band. For SCC DL RB size and offset will base on the PCC corresponding RB allocation.
- vi. For non-contiguous intra-band CA, the SCC selected to provide maximum separation from the PCC and must remain fully within the downlink transmission band. For SCC DL RB size and offset will base on the PCC corresponding RB allocation.
- vii. For Intra-band, contiguous CA, the downlink channels selected to perform the uplink power measurement must satisfy 3GPP channel spacing (5.4.1A of 3GPP TS 36.521 or equivalent) and channel bandwidth (5.4.2A) requirements.

$$\text{Nominal channel spacing} = \left\lceil \frac{BW_{\text{Channel}(1)} + BW_{\text{Channel}(2)} - 0.1|BW_{\text{Channel}(1)} - BW_{\text{Channel}(2)}|}{0.6} \right\rceil 0.3 \text{ [MHz]}$$

<Maximum Average RF Power (Proximity Sensor Off)>

<Two Carrier power verification>

Configure		CA Configuration (BCS)	PCC							SCC				Power	
			LTE Band	BW (MHz)	UL Freq. (MHz)	UL Channel	Mod.	UL# RB	UL RB Offset	LTE Band	BW (MHz)	DL Freq. (MHz)	DL Channel	With CA Tx. Power (dBm)	Without CA Tx. Power (dBm)
Intra-Band	Contiguous	CA_7C	Band 7	20M	2560	21350	QPSK	1	99	Band 7	20M	2660.2	3152	22.85	22.88
		CA_38C	Band 38	20M	2580	37850	QPSK	1	99	Band 38	20M	2599.8	38048	22.88	22.90

<Maximum Average RF Power (Proximity Sensor On)>

<Two Carrier power verification>

Configure		CA Configuration (BCS)	PCC							SCC				Power	
			LTE Band	BW (MHz)	UL Freq. (MHz)	UL Channel	Mod.	UL# RB	UL RB Offset	LTE Band	BW (MHz)	DL Freq. (MHz)	DL Channel	With CA Tx. Power (dBm)	Without CA Tx. Power (dBm)
Intra-Band	Contiguous	CA_7C	Band 7	20M	2560	21350	QPSK	1	99	Band 7	20M	2660.2	3152	19.78	19.84
		CA_38C	Band 38	20M	2580	37850	QPSK	1	99	Band 38	20M	2599.8	38048	20.63	20.75

LTE Carrier Aggregation Conducted Power (Uplink)

1. This device supports uplink carrier aggregation for LTE CA_7C, CA_38C with a maximum of two 20MHz component carriers. For intra band contiguous carrier aggregation scenarios, 3GPP 36.101 Table 6.2.2A-1 specifies that the aggregate maximum allowed output power is equivalent to the single carrier scenario. For the non-contiguously allocated resource blocks which the MPR level is determined by various RB separation and RB sizes requirement, and the allowed MPR levels, settings and the conducted powers are permanently implemented in this device per the 3GPP 36.36.101 section 6.2.3A.1.3 requirements.
2. According to November 2017 TCB workshop, the output power with uplink CA active was measured for the high / middle / low channel configuration with the highest reported SAR for each exposure condition, the power was measured with wideband signal integration over both component carriers.
3. In applying the power measurement procedures of KDB 941225 D05A for DL CA to qualify for UL SAR test exclusion, power measurement is required only for the subset in each row with the largest combination of frequency bands and CCs
4. Maximum output power measurement is required for each UL CA configuration for the required test channels described in KDB 941225 D05. The required test channel should be associated with the UL PCC. For channels at the ends of a frequency band, the SCC and subsequent CCs are added to the side within the transmission band. Otherwise, the CCs should be added alternatively to either side of the PCC.

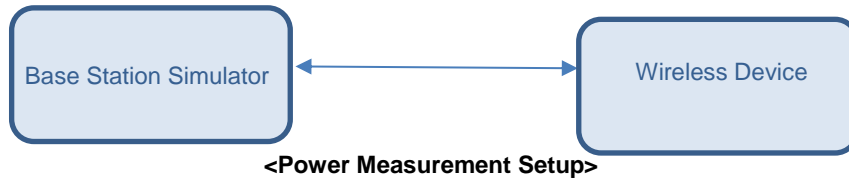



<CA_7C>

Power State	Combination	PCC							SCC							Power		
		PCC Band	PCC Bandwidth (MHz)	PCC (UL) Channel	PCC (UL) Frequency (MHz)	Modulation	PCC UL#	PCC UL RB Offset	SCC Band	SCC Bandwidth (MHz)	SCC (UL) Channel	SCC (UL) Frequency (MHz)	Modulation	SCC UL#	SCC UL RB Offset	ULCA Tx. Power (dBm)	ULCA Tune up Power (dBm)	Single Carrier Target. Power (dBm)
P-Sensor Off	CA_7C	LTE B7	20	20850	2510	QPSK	1	99	LTE B7	20	21048	2529.8	QPSK	0	0	22.84	24.00	24.00
		LTE B7	20	21100	2535	QPSK	1	99	LTE B7	20	20902	2515.2	QPSK	0	0	22.92	24.00	24.00
		LTE B7	20	21350	2560	QPSK	1	99	LTE B7	20	21152	2540.2	QPSK	0	0	22.81	24.00	24.00
P-Sensor On	CA_7C	LTE B7	20	20850	2510	QPSK	1	99	LTE B7	20	21048	2529.8	QPSK	0	0	19.52	20.50	20.50
		LTE B7	20	21100	2535	QPSK	1	99	LTE B7	20	20902	2515.2	QPSK	0	0	19.63	20.50	20.50
		LTE B7	20	21350	2560	QPSK	1	99	LTE B7	20	21152	2540.2	QPSK	0	0	19.82	20.50	20.50

<CA_38C>

Power State	Combination	PCC							SCC							Power		
		PCC Band	PCC Bandwidth (MHz)	PCC (UL/DL) Channel	PCC (UL/DL) Frequency (MHz)	Modulation	PCC UL#	PCC UL RB Offset	SCC Band	SCC Bandwidth (MHz)	SCC (UL/DL) Channel	SCC (UL/DL) Frequency (MHz)	Modulation	SCC UL#	SCC UL RB Offset	ULCA Tx. Power (dBm)	ULCA Tune up Power (dBm)	Single Carrier Target. Power (dBm)
P-Sensor Off	CA_38C	LTE B38	20	37850	2580	QPSK	1	49	LTE B38	20	38048	2599.8	QPSK	0	0	22.85	24.30	24.30
		LTE B38	20	37901	2585.1	QPSK	1	49	LTE B38	20	38099	2604.9	QPSK	0	0	22.92	24.30	24.30
		LTE B38	20	38150	2610	QPSK	1	49	LTE B38	20	37952	2590.2	QPSK	0	0	22.91	24.30	24.30
P-Sensor On	CA_38C	LTE B38	20	37850	2580	QPSK	1	49	LTE B38	20	38048	2599.8	QPSK	0	0	20.52	22.00	22.00
		LTE B38	20	37901	2585.1	QPSK	1	49	LTE B38	20	38099	2604.9	QPSK	0	0	20.66	22.00	22.00
		LTE B38	20	38150	2610	QPSK	1	49	LTE B38	20	37952	2590.2	QPSK	0	0	20.65	22.00	22.00



<WLAN Conducted Power>

General Note:

3. Per KDB 248227 D01v02r02, SAR test reduction is determined according to 802.11 transmission mode configurations and certain exposure conditions with multiple test positions. In the 2.4 GHz band, separate SAR procedures are applied to DSSS and OFDM configurations to simplify DSSS test requirements. For OFDM, in both 2.4 and 5 GHz bands, an initial test configuration must be determined for each standalone and aggregated frequency band, according to the transmission mode configuration with the highest maximum output power specified for production units to perform SAR measurements. If the same highest maximum output power applies to different combinations of channel bandwidths, modulations and data rates, additional procedures are applied to determine which test configurations require SAR measurement. When applicable, an initial test position may be applied to reduce the number of SAR measurements required for next to the ear, UMPC mini-tablet or hotspot mode configurations with multiple test positions.
4. For 2.4 GHz 802.11b DSSS, either the initial test position procedure for multiple exposure test positions or the DSSS procedure for fixed exposure position is applied; these are mutually exclusive. For 2.4 GHz and 5 GHz OFDM configurations, the initial test configuration is applied to measure SAR using either the initial test position procedure for multiple exposure test position configurations or the initial test configuration procedures for fixed exposure test conditions. Based on the reported SAR of the measured configurations and maximum output power of the transmission mode configurations that are not included in the initial test configuration, the subsequent test configuration and initial test position procedures are applied to determine if SAR measurements are required for the remaining OFDM transmission configurations. In general, the number of test channels that require SAR measurement is minimized based on maximum output power measured for the test sample(s).
5. For OFDM transmission configurations in the 2.4 GHz and 5 GHz bands, When the same maximum power is specified for multiple transmission modes in a frequency band, the largest channel bandwidth, lowest order modulation, lowest data rate and lowest order 802.11a/g/n/ac mode is used for SAR measurement, on the highest measured output power channel for each frequency band.
6. DSSS and OFDM configurations are considered separately according to the required SAR procedures. SAR is measured in the initial test position using the 802.11 transmission mode configuration required by the DSSS procedure or initial test configuration and subsequent test configuration(s) according to the OFDM procedures.18 The initial test position procedure is described in the following:
 - a. When the reported SAR of the initial test position is ≤ 0.4 W/kg, further SAR measurement is not required for the other test positions in that exposure configuration and 802.11 transmission mode combinations within the frequency band or aggregated band.
 - b. When the reported SAR of the test position is > 0.4 W/kg, SAR is repeated for the 802.11 transmission mode configuration tested in the initial test position to measure the subsequent next closet/smallest test separation distance and maximum coupling test position on the highest maximum output power channel, until the report SAR is ≤ 0.8 W/kg or all required test position are tested.
 - c. For all positions/configurations, when the reported SAR is > 0.8 W/kg, SAR is measured for these test positions/configurations on the subsequent next highest measured output power channel(s) until the reported SAR is ≤ 1.2 W/kg or all required channels are tested.

<2.4GHz WLAN>

	Mode	Channel	Frequency (MHz)	Average power (dBm)	Tune-Up Limit	Duty Cycle %
2.4GHz WLAN	802.11b 1Mbps	1	2412	16.93	18.50	100.00
		6	2437	16.81	18.50	
		11	2462	17.05	18.50	
	802.11g 6Mbps	1	2412	14.09	15.50	95.34
		6	2437	13.83	15.50	
		11	2462	14.02	15.50	
	802.11n-HT20 MCS0	1	2412	11.78	13.50	95.00
		6	2437	11.65	13.50	
		11	2462	11.83	13.50	
	802.11n-HT40 MCS0	3	2422	11.86	13.50	90.97
		6	2437	11.64	13.50	
		9	2452	11.83	13.50	



<5GHz WLAN>

	Mode	Channel	Frequency (MHz)	Average power (dBm)	Tune-Up Limit	Duty Cycle %
5.2GHz WLAN	802.11a 6Mbps	36	5180	15.98	16.50	95.00
		40	5200	16.03	16.50	
		44	5220	16.08	16.50	
		48	5240	16.25	16.50	
	802.11n-HT20 MCS0	36	5180	13.93	15.00	95.00
		40	5200	13.97	15.00	
		44	5220	13.96	15.00	
		48	5240	13.99	15.00	
	802.11n-HT40 MCS0	38	5190	13.69	15.00	90.97
		46	5230	13.74	15.00	
	802.11ac-VHT20 MCS0	36	5180	11.75	13.00	95.02
		40	5200	11.78	13.00	
		44	5220	11.83	13.00	
		48	5240	12.03	13.00	
	802.11ac-VHT40 MCS0	38	5190	11.77	13.00	91.67
		46	5230	11.84	13.00	
802.11ac-VHT80 MCS0	42	5210	11.82	13.00	83.77	

	Mode	Channel	Frequency (MHz)	Average power (dBm)	Tune-Up Limit	Duty Cycle %
5.3GHz WLAN	802.11a 6Mbps	52	5260	16.27	16.50	95.00
		56	5280	16.10	16.50	
		60	5300	15.98	16.50	
		64	5320	15.68	16.50	
	802.11n-HT20 MCS0	52	5260	13.95	15.00	95.00
		56	5280	13.89	15.00	
		60	5300	13.85	15.00	
		64	5320	13.63	15.00	
	802.11n-HT40 MCS0	54	5270	13.85	15.00	90.97
		62	5310	13.75	15.00	
	802.11ac-VHT20 MCS0	52	5260	11.98	13.00	95.02
		56	5280	11.85	13.00	
		60	5300	11.70	13.00	
		64	5320	11.54	13.00	
	802.11ac-VHT40 MCS0	54	5270	11.82	13.00	91.67
		62	5310	11.64	13.00	
802.11ac-VHT80 MCS0	58	5290	11.79	13.00	83.77	



	Mode	Channel	Frequency (MHz)	Average power (dBm)	Tune-Up Limit	Duty Cycle %
5.5GHz WLAN	802.11a 6Mbps	100	5500	15.88	16.50	95.00
		116	5580	15.55	16.50	
		132	5660	15.58	16.50	
		140	5700	15.77	16.50	
		144	5720	15.87	16.50	
	802.11n-HT20 MCS0	100	5500	13.97	15.00	95.00
		116	5580	13.48	15.00	
		132	5660	13.78	15.00	
		140	5700	13.65	15.00	
		144	5720	13.94	15.00	
	802.11n-HT40 MCS0	102	5510	13.84	15.00	90.97
		110	5550	13.62	15.00	
		134	5670	13.76	15.00	
		142	5710	13.64	15.00	
	802.11ac-VHT20 MCS0	100	5500	11.90	13.00	95.02
		116	5580	11.38	13.00	
		132	5660	11.53	13.00	
		140	5700	11.57	13.00	
		144	5720	11.87	13.00	
	802.11ac-VHT40 MCS0	102	5510	11.80	13.00	91.67
		110	5550	11.36	13.00	
		134	5670	11.44	13.00	
		142	5710	11.66	13.00	
	802.11ac-VHT80 MCS0	106	5530	11.71	13.00	83.77
138		5690	11.65	13.00		



	Mode	Channel	Frequency (MHz)	Average power (dBm)	Tune-Up Limit	Duty Cycle %
5.8GHz WLAN	802.11a MCS0	149	5745	15.33	16.50	95.00
		157	5785	15.29	16.50	
		161	5805	15.34	16.50	
	802.11n-HT20 MCS0	149	5745	13.41	15.00	95.00
		157	5785	13.21	15.00	
		161	5805	13.15	15.00	
	802.11n-HT40 MCS0	151	5755	13.77	15.00	90.97
		159	5795	13.63	15.00	
	802.11ac-VHT20 MCS0	149	5745	11.61	13.00	95.02
		157	5785	11.35	13.00	
		161	5805	11.36	13.00	
	802.11ac-VHT40 MCS0	151	5755	11.93	13.00	91.67
		159	5795	11.75	13.00	
	802.11ac-VHT80 MCS0	155	5775	11.88	13.00	83.77

<2.4GHz Bluetooth>

General Note:

1. For 2.4GHz Bluetooth SAR testing was selected 1Mbps, due to its highest average power.
2. The Bluetooth duty cycle is 76.63 % as following figure, according to 2016 Oct. TCB workshop for Bluetooth SAR scaling need further consideration and the theoretical duty cycle is 83.3%, therefore the actual duty cycle will be scaled up to the theoretical value of Bluetooth reported SAR calculation

Mode	Channel	Frequency (MHz)	Data Rate
			1Mbps
BR/EDR	CH 00	2402	8.82
	CH 39	2441	8.61
	CH 78	2480	8.87
Tune-up Limit			10.00

Mode	Channel	Frequency (MHz)	Average power (dBm)
			GFSK
LE	CH 00	2402	-3.71
	CH 19	2440	-3.10
	CH 39	2480	-1.91
Tune-up Limit			-1.00

14. Antenna Location

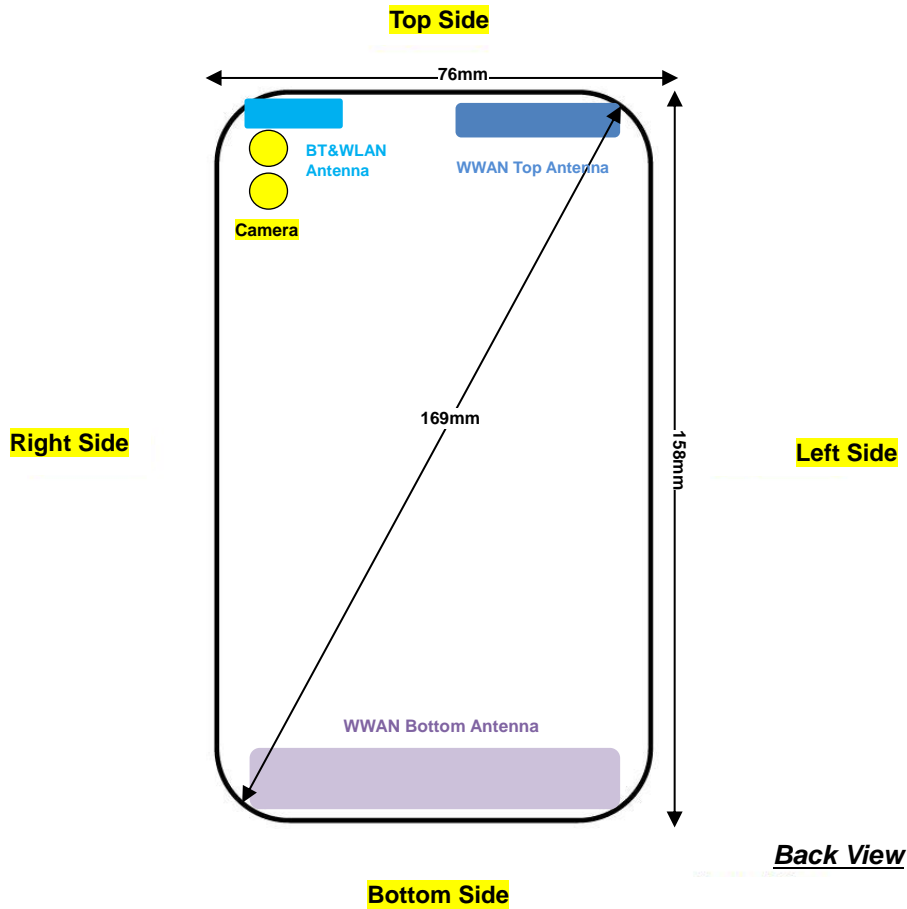

Antenna	Support Band
WWAN Top Antenna	GSM: 850 / 1900 WCDMA: B2 / B4 / B5 LTE: B4 / B5 / B7 / B38
WWAN Bottom Antenna	GSM: 850 / 1900 WCDMA: B2 / B4 / B5 LTE: B4 / B5 / B7 / B38
BT/WLAN 2.4GHz/ WLAN 5GHz Antenna	WLAN 2.4GHz WLAN 5GHz Bluetooth

Distance of the Antenna to the EUT surface/edge						
Antennas	Back	Front	Top Side	Bottom Side	Right Side	Left Side
WWAN Top Antenna	≤ 25mm	≤ 25mm	≤ 25mm	>25mm	>25mm	≤ 25mm
WWAN Bottom Antenna	≤ 25mm	≤ 25mm	>25mm	≤ 25mm	≤ 25mm	≤ 25mm
BT&WLAN Antenna	≤ 25mm	≤ 25mm	≤ 25mm	>25mm	≤ 25mm	>25mm

Positions for SAR tests; Hotspot mode						
Antennas	Back	Front	Top Side	Bottom Side	Right Side	Left Side
WWAN Top Antenna	Yes	Yes	Yes	No	No	Yes
WWAN Bottom Antenna	Yes	Yes	No	Yes	Yes	Yes
BT&WLAN Antenna	Yes	Yes	Yes	No	Yes	No

General Note:

Referring to KDB 941225 D06 v02r01, when the overall device length and width are ≥ 9cm*5cm, the test distance is 10 mm. SAR must be measured for all sides and surfaces with a transmitting antenna located within 25mm from that surface or edge.



15. SAR Test Results

General Note:

1. Per KDB 447498 D01v06, the reported SAR is the measured SAR value adjusted for maximum tune-up tolerance.
 - a. Tune-up scaling Factor = tune-up limit power (mW) / EUT RF power (mW), where tune-up limit is the maximum rated power among all production units.
 - b. For SAR testing of WLAN signal with non-100% duty cycle, the measured SAR is scaled-up by the duty cycle scaling factor which is equal to "1/(duty cycle)"
 - c. For WWAN: Reported SAR(W/kg)= Measured SAR(W/kg)*Tune-up Scaling Factor
 - d. For WLAN/Bluetooth: Reported SAR(W/kg)= Measured SAR(W/kg)* Duty Cycle scaling factor * Tune-up scaling factor
 - e. For TDD LTE SAR measurement, the duty cycle 1:1.59 (62.9 %) was used perform testing and considering the theoretical duty cycle of 63.3% for extended cyclic prefix in the uplink, and the theoretical duty cycle of 62.9% for normal cyclic prefix in uplink, a scaling factor of extended cyclic prefix 63.3%/62.9% = 1.006 is applied to scale-up the measured SAR result.
The Reported TDD LTE SAR = measured SAR (W/kg) * Tune-up Scaling Factor* scaling factor for extended cyclic prefix.
2. Per KDB 447498 D01v06, for each exposure position, testing of other required channels within the operating mode of a frequency band is not required when the *reported* 1-g or 10-g SAR for the mid-band or highest output power channel is:
 - ≤ 0.8 W/kg or 2.0 W/kg, for 1-g or 10-g respectively, when the transmission band is ≤ 100 MHz
 - ≤ 0.6 W/kg or 1.5 W/kg, for 1-g or 10-g respectively, when the transmission band is between 100 MHz and 200 MHz
 - ≤ 0.4 W/kg or 1.0 W/kg, for 1-g or 10-g respectively, when the transmission band is ≥ 200 MHz
3. Per KDB 865664 D01v01r04, for each frequency band, repeated SAR measurement is required when the measured SAR is ≥ 0.8 W/kg. Per KDB 865664 D01v01r04, if the extremity repeated SAR is necessary, the same procedures should be adapted for measurements according to extremity and occupational exposure limits by applying a factor of 2.5 for extremity exposure and a factor of 5 for occupational exposure to the corresponding SAR thresholds.
4. Per KDB 648474 D04v01r03, when the reported SAR for a body-worn accessory measured without a headset connected to the handset is ≤ 1.2 W/kg, SAR testing with a headset connected to the handset is not required.
5. The device employs proximity sensors that detect the presence of the user's body at the front or back or top side or bottom side faces of the device. When front or back or top side or bottom side condition is detected, GSM1900, WCDMA B2 / B4 and LTE B4 / B7 / B38 reduced power will be active.
6. Per KDB648474 D04v01r03, for smart phones with a display diagonal dimension > 15.0 cm or an overall diagonal dimension > 16.0 cm, when hotspot mode applies, 10-g extremity SAR is required only for the surfaces and edges with hotspot mode 1-g reported SAR > 1.2 W/kg, however, when power reduction applies to hotspot mode the measured SAR must be scaled to the maximum output power, including tolerance, allowed for phablet modes to compare with the 1.2 W/kg SAR test reduction threshold.
 - a. WLAN 5.3/5.5GHz tested the product specific 10g SAR since it has no hotspot mode.
 - b. For hotspot mode, GSM1900, WCDMA band 2/4, LTE band 4/7/38 with sensor on reduced power for front/back/top/bottom face, according to extremity handheld state ,the device will trigger sensor reduced power on these face, so for SAR scaled to this reduced power level, there are no change for SAR value. The maximum SAR is less than 1.2W/Kg, so no need to perform WWAN extremity SAR.
 - c. When 10-g product specific 10g SAR is considered, SAR thresholds is specified in the procedures for SAR test reduction and exclusion should be multiplied by 2.5.

**GSM Note:**

1. Per KDB 941225 D01v03r01, for SAR test reduction for GSM / GPRS / EDGE modes is determined by the source-based time-averaged output power including tune-up tolerance. The mode with highest specified time-averaged output power should be tested for SAR compliance in the applicable exposure conditions. For modes with the same specified maximum output power and tolerance, the higher number time-slot configuration should be tested. Therefore, the GPRS 4Tx slots for GSM850/GSM1900 are considered as the primary mode.
2. Other configurations of GSM / GPRS / EDGE are considered as secondary modes. The 3G SAR test reduction procedure is applied, when the maximum output power and tune-up tolerance specified for production units in a secondary mode is $\leq 1/4$ dB higher than the primary mode, SAR measurement is not required for the secondary mode.
3. Power reduction which is triggered by p-sensor on is implemented in GSM1900 band, for SAR testing EUT was set in reduced power mode and GPRS 4Tx slots due to its highest frame-average power.

WCDMA Note:

1. Per KDB 941225 D01v03r01, for SAR testing is measured using a 12.2 kbps RMC with TPC bits configured to all "1's".
2. Per KDB 941225 D01v03r01, RMC 12.2kbps setting is used to evaluate SAR. The maximum output power and tune-up tolerance specified for production units in HSDPA / HSUPA / DC-HSDPA is $\leq 1/4$ dB higher than RMC 12.2Kbps or when the highest reported SAR of the RMC12.2Kbps is scaled by the ratio of specified maximum output power and tune-up tolerance of HSDPA / HSUPA / DC-HSDPA to RMC12.2Kbps and the adjusted SAR is ≤ 1.2 W/kg, SAR measurement is not required for HSDPA / HSUPA / DC-HSDPA, and according to the following RF output power, the output power results of the secondary modes (HSDPA / HSUPA / DC-HSDPA) are less than $1/4$ dB higher than the primary modes; therefore, SAR measurement is not required for HSDPA / HSUPA / DC-HSDPA.

LTE Note:

1. Per KDB 941225 D05v02r05, start with the largest channel bandwidth and measure SAR for QPSK with 1 RB allocation, using the RB offset and required test channel combination with the highest maximum output power for RB offsets at the upper edge, middle and lower edge of each required test channel.
2. Per KDB 941225 D05v02r05, 50% RB allocation for QPSK SAR testing follows 1RB QPSK allocation procedure.
3. Per KDB 941225 D05v02r05, For QPSK with 100% RB allocation, SAR is not required when the highest maximum output power for 100 % RB allocation is less than the highest maximum output power in 50% and 1 RB allocations and the highest reported SAR for 1 RB and 50% RB allocation are ≤ 0.8 W/kg. Otherwise, SAR is measured for the highest output power channel; and if the reported SAR is > 1.45 W/kg, the remaining required test channels must also be tested.
4. Per KDB 941225 D05v02r05, 16QAM/64QAM output power for each RB allocation configuration is $>$ not $1/2$ dB higher than the same configuration in QPSK and the reported SAR for the QPSK configuration is ≤ 1.45 W/kg; Per KDB 941225 D05v02r05, 16QAM/64QAM SAR testing is not required.
5. Per KDB 941225 D05v02r05, smaller bandwidth output power for each RB allocation configuration is $>$ not $1/2$ dB higher than the same configuration in the largest supported bandwidth, and the reported SAR for the largest supported bandwidth is ≤ 1.45 W/kg; Per KDB 941225 D05v02r05, smaller bandwidth SAR testing is not required.
6. According to November 2017 TCB workshop, the following applied to intra-band contiguous UL CA only;
 - a. Maximum output power measurement is required for each UL CA configuration for the required test channels described in KDB 941225 D05. The required test channel should be associated with the UL PCC. For channels at the ends of a frequency band, the SCC and subsequent CCs are added to the side within the transmission band. Otherwise, the CCs should be added alternatively to either side of the PCC.
 - b. UL CA SAR is measured for each exposure condition in each frequency band using the highest SAR configuration tested in standalone LTE mode to establish the UL CA PCC. The SCC and subsequent CC must use configurations similar to the PCC to establish conservative or worst case equivalent SAR test conditions.
 - c. When the SAR configuration tested in step b) has a maximum output power specification more than $1/4$ dB lower than the highest maximum output power conditions measured in the power measurements in step a) above and the reported SAR in step b) is larger than 1.2 W/kg, SAR measurement is also required for the configuration in step a)
 - d. All standalone SAR configurations with SAR > 1.2 W/kg must also be tested by applying the procedures in step b)
7. For LTE B4 / B5 / B38 the maximum bandwidth does not support three non-overlapping channels, per KDB 941225 D05v02r05, when a device supports overlapping channel assignment in a channel bandwidth configuration, the middle channel of the group of overlapping channels should be selected for testing.



WLAN Note:

1. Per KDB 248227 D01v02r02, for 2.4GHz 802.11g/n SAR testing is not required when the highest reported SAR for DSSS is adjusted by the ratio of OFDM to DSSS specified maximum output power and the adjusted SAR is ≤ 1.2 W/kg.
2. Per KDB 248227 D01v02r02, U-NII-1 SAR testing is not required when the U-NII-2A band highest reported SAR for a test configuration is ≤ 1.2 W/kg, SAR is not required for U-NII-1 band.
3. When the reported SAR of the test position is > 0.4 W/kg, SAR is repeated for the 802.11 transmission mode configuration tested in the initial test position to measure the subsequent next closet/smallest test separation distance and maximum coupling test position on the highest maximum output power channel, until the report SAR is ≤ 0.8 W/kg or all required test position are tested.
4. For all positions / configurations, when the reported SAR is > 0.8 W/kg, SAR is measured for these test positions / configurations on the subsequent next highest measured output power channel(s) until the reported SAR is ≤ 1.2 W/kg or all required channels are tested.
5. During SAR testing the WLAN transmission was verified using a spectrum analyzer.



15.1 Head SAR

<GSM SAR>

Plot No.	Band	Mode	Test Position	Antenna	Power Mode	Ch.	Freq. (MHz)	Average Power (dBm)	Tune-Up Limit (dBm)	Tune-up Scaling Factor	Power Drift (dB)	Measured 1g SAR (W/kg)	Reported 1g SAR (W/kg)
01	GSM 850	GPRS (4 Tx slots)	Right Cheek	Top	P-Sensor Off	251	848.8	29.04	30.00	1.247	0.01	0.322	0.402
	GSM 850	GPRS (4 Tx slots)	Right Tilted	Top	P-Sensor Off	251	848.8	29.04	30.00	1.247	-0.01	0.297	0.370
	GSM 850	GPRS (4 Tx slots)	Left Cheek	Top	P-Sensor Off	251	848.8	29.04	30.00	1.247	0.01	0.252	0.314
	GSM 850	GPRS (4 Tx slots)	Left Tilted	Top	P-Sensor Off	251	848.8	29.04	30.00	1.247	-0.08	0.257	0.321
	GSM 850	GPRS (4 Tx slots)	Right Cheek	Bottom	P-Sensor Off	251	848.8	29.04	30.00	1.247	0.08	0.107	0.133
	GSM 850	GPRS (4 Tx slots)	Right Tilted	Bottom	P-Sensor Off	251	848.8	29.04	30.00	1.247	-0.02	0.054	0.067
	GSM 850	GPRS (4 Tx slots)	Left Cheek	Bottom	P-Sensor Off	251	848.8	29.04	30.00	1.247	0.01	0.112	0.140
	GSM 850	GPRS (4 Tx slots)	Left Tilted	Bottom	P-Sensor Off	251	848.8	29.04	30.00	1.247	0.04	0.053	0.066
	GSM 1900	GPRS (4 Tx slots)	Right Cheek	Top	P-Sensor On	512	1850.2	23.08	23.50	1.102	-0.05	0.485	0.534
	02	GSM 1900	GPRS (4 Tx slots)	Right Tilted	Top	P-Sensor On	512	1850.2	23.08	23.50	1.102	0.03	0.585
GSM 1900		GPRS (4 Tx slots)	Left Cheek	Top	P-Sensor On	512	1850.2	23.08	23.50	1.102	-0.06	0.290	0.319
GSM 1900		GPRS (4 Tx slots)	Left Tilted	Top	P-Sensor On	512	1850.2	23.08	23.50	1.102	-0.06	0.366	0.403
GSM 1900		GPRS (4 Tx slots)	Right Cheek	Bottom	P-Sensor On	512	1850.2	23.08	23.50	1.102	0.01	0.031	0.034
GSM 1900		GPRS (4 Tx slots)	Right Tilted	Bottom	P-Sensor On	512	1850.2	23.08	23.50	1.102	0.18	0.018	0.020
GSM 1900		GPRS (4 Tx slots)	Left Cheek	Bottom	P-Sensor On	512	1850.2	23.08	23.50	1.102	0.02	0.021	0.023
GSM 1900		GPRS (4 Tx slots)	Left Tilted	Bottom	P-Sensor On	512	1850.2	23.08	23.50	1.102	0.15	0.016	0.018

<WCDMA SAR>

Plot No.	Band	Mode	Test Position	Antenna	Power Mode	Ch.	Freq. (MHz)	Average Power (dBm)	Tune-Up Limit (dBm)	Tune-up Scaling Factor	Power Drift (dB)	Measured 1g SAR (W/kg)	Reported 1g SAR (W/kg)	
03	WCDMA Band V	RMC 12.2Kbps	Right Cheek	Top	P-Sensor Off	4233	846.6	23.58	24.00	1.102	-0.05	0.248	0.273	
	WCDMA Band V	RMC 12.2Kbps	Right Tilted	Top	P-Sensor Off	4233	846.6	23.58	24.00	1.102	0.01	0.231	0.254	
	WCDMA Band V	RMC 12.2Kbps	Left Cheek	Top	P-Sensor Off	4233	846.6	23.58	24.00	1.102	-0.03	0.184	0.203	
	WCDMA Band V	RMC 12.2Kbps	Left Tilted	Top	P-Sensor Off	4233	846.6	23.58	24.00	1.102	-0.02	0.187	0.206	
	WCDMA Band V	RMC 12.2Kbps	Right Cheek	Bottom	P-Sensor Off	4233	846.6	23.58	24.00	1.102	0.01	0.072	0.079	
	WCDMA Band V	RMC 12.2Kbps	Right Tilted	Bottom	P-Sensor Off	4233	846.6	23.58	24.00	1.102	0.16	0.042	0.046	
	WCDMA Band V	RMC 12.2Kbps	Left Cheek	Bottom	P-Sensor Off	4233	846.6	23.58	24.00	1.102	-0.03	0.08	0.088	
	WCDMA Band V	RMC 12.2Kbps	Left Tilted	Bottom	P-Sensor Off	4233	846.6	23.58	24.00	1.102	-0.03	0.04	0.044	
	WCDMA Band IV	RMC 12.2Kbps	Right Cheek	Top	P-Sensor On	1413	1732.6	20.28	21.50	1.324	-0.03	0.471	0.624	
	04	WCDMA Band IV	RMC 12.2Kbps	Right Tilted	Top	P-Sensor On	1413	1732.6	20.28	21.50	1.324	-0.01	0.474	0.628
WCDMA Band IV		RMC 12.2Kbps	Left Cheek	Top	P-Sensor On	1413	1732.6	20.28	21.50	1.324	-0.02	0.293	0.388	
WCDMA Band IV		RMC 12.2Kbps	Left Tilted	Top	P-Sensor On	1413	1732.6	20.28	21.50	1.324	-0.01	0.334	0.442	
WCDMA Band IV		RMC 12.2Kbps	Right Cheek	Bottom	P-Sensor On	1413	1732.6	20.28	21.50	1.324	0.12	0.079	0.105	
WCDMA Band IV		RMC 12.2Kbps	Right Tilted	Bottom	P-Sensor On	1413	1732.6	20.28	21.50	1.324	0.03	0.038	0.050	
WCDMA Band IV		RMC 12.2Kbps	Left Cheek	Bottom	P-Sensor On	1413	1732.6	20.28	21.50	1.324	-0.02	0.046	0.061	
WCDMA Band IV		RMC 12.2Kbps	Left Tilted	Bottom	P-Sensor On	1413	1732.6	20.28	21.50	1.324	-0.08	0.045	0.060	
WCDMA Band II		RMC 12.2Kbps	Right Cheek	Top	P-Sensor On	9262	1852.4	20.10	20.50	1.096	-0.07	0.640	0.702	
05		WCDMA Band II	RMC 12.2Kbps	Right Tilted	Top	P-Sensor On	9262	1852.4	20.10	20.50	1.096	-0.02	0.658	0.721
		WCDMA Band II	RMC 12.2Kbps	Left Cheek	Top	P-Sensor On	9262	1852.4	20.10	20.50	1.096	-0.05	0.392	0.430
	WCDMA Band II	RMC 12.2Kbps	Left Tilted	Top	P-Sensor On	9262	1852.4	20.10	20.50	1.096	0.01	0.413	0.453	
	WCDMA Band II	RMC 12.2Kbps	Right Cheek	Bottom	P-Sensor On	9262	1852.4	20.10	20.50	1.096	0.01	0.043	0.047	
	WCDMA Band II	RMC 12.2Kbps	Right Tilted	Bottom	P-Sensor On	9262	1852.4	20.10	20.50	1.096	0.02	0.015	0.016	
	WCDMA Band II	RMC 12.2Kbps	Left Cheek	Bottom	P-Sensor On	9262	1852.4	20.10	20.50	1.096	-0.02	0.035	0.038	
	WCDMA Band II	RMC 12.2Kbps	Left Tilted	Bottom	P-Sensor On	9262	1852.4	20.10	20.50	1.096	-0.05	0.037	0.041	



<FDD LTE SAR>

Plot No.	Band	BW (MHz)	Modulation	RB Size	RB Offset	Test Position	Antenna	Power Mode	Ch.	Freq. (MHz)	Average Power (dBm)	Tune-Up Limit (dBm)	Tune-up Scaling Factor	Power Drift (dB)	Measured 1g SAR (W/kg)	Reported 1g SAR (W/kg)
06	LTE Band 5	10M	QPSK	1	0	Right Cheek	Top	P-Sensor Off	20525	836.5	22.90	24.00	1.288	-0.01	0.211	0.272
	LTE Band 5	10M	QPSK	25	12	Right Cheek	Top	P-Sensor Off	20525	836.5	21.96	23.00	1.271	-0.01	0.179	0.227
	LTE Band 5	10M	QPSK	1	0	Right Tilted	Top	P-Sensor Off	20525	836.5	22.90	24.00	1.288	-0.04	0.206	0.265
	LTE Band 5	10M	QPSK	25	12	Right Tilted	Top	P-Sensor Off	20525	836.5	21.96	23.00	1.271	0.04	0.164	0.208
	LTE Band 5	10M	QPSK	1	0	Left Cheek	Top	P-Sensor Off	20525	836.5	22.90	24.00	1.288	-0.02	0.168	0.216
	LTE Band 5	10M	QPSK	25	12	Left Cheek	Top	P-Sensor Off	20525	836.5	21.96	23.00	1.271	0.01	0.132	0.168
	LTE Band 5	10M	QPSK	1	0	Left Tilted	Top	P-Sensor Off	20525	836.5	22.90	24.00	1.288	-0.04	0.168	0.216
	LTE Band 5	10M	QPSK	25	12	Left Tilted	Top	P-Sensor Off	20525	836.5	21.96	23.00	1.271	0.02	0.133	0.169
	LTE Band 5	10M	QPSK	1	0	Right Cheek	Bottom	P-Sensor Off	20525	836.5	22.90	24.00	1.288	0.03	0.061	0.079
	LTE Band 5	10M	QPSK	25	12	Right Cheek	Bottom	P-Sensor Off	20525	836.5	21.96	23.00	1.271	-0.12	0.052	0.066
	LTE Band 5	10M	QPSK	1	0	Right Tilted	Bottom	P-Sensor Off	20525	836.5	22.90	24.00	1.288	0.02	0.034	0.044
	LTE Band 5	10M	QPSK	25	12	Right Tilted	Bottom	P-Sensor Off	20525	836.5	21.96	23.00	1.271	0.11	0.030	0.038
	LTE Band 5	10M	QPSK	1	0	Left Cheek	Bottom	P-Sensor Off	20525	836.5	22.90	24.00	1.288	0.12	0.064	0.082
	LTE Band 5	10M	QPSK	25	12	Left Cheek	Bottom	P-Sensor Off	20525	836.5	21.96	23.00	1.271	-0.01	0.053	0.067
	LTE Band 5	10M	QPSK	1	0	Left Tilted	Bottom	P-Sensor Off	20525	836.5	22.90	24.00	1.288	-0.09	0.032	0.041
	LTE Band 5	10M	QPSK	25	12	Left Tilted	Bottom	P-Sensor Off	20525	836.5	21.96	23.00	1.271	0.03	0.027	0.034
	LTE Band 4	20M	QPSK	1	0	Right Cheek	Top	P-Sensor On	20175	1732.5	19.68	20.50	1.208	0	0.389	0.470
	LTE Band 4	20M	QPSK	50	0	Right Cheek	Top	P-Sensor On	20175	1732.5	18.73	19.50	1.194	-0.03	0.360	0.430
07	LTE Band 4	20M	QPSK	1	0	Right Tilted	Top	P-Sensor On	20175	1732.5	19.68	20.50	1.208	0.01	0.439	0.530
	LTE Band 4	20M	QPSK	50	0	Right Tilted	Top	P-Sensor On	20175	1732.5	18.73	19.50	1.194	-0.01	0.398	0.475
	LTE Band 4	20M	QPSK	1	0	Left Cheek	Top	P-Sensor On	20175	1732.5	19.68	20.50	1.208	-0.1	0.274	0.331
	LTE Band 4	20M	QPSK	50	0	Left Cheek	Top	P-Sensor On	20175	1732.5	18.73	19.50	1.194	-0.1	0.220	0.263
	LTE Band 4	20M	QPSK	1	0	Left Tilted	Top	P-Sensor On	20175	1732.5	19.68	20.50	1.208	-0.03	0.315	0.380
	LTE Band 4	20M	QPSK	50	0	Left Tilted	Top	P-Sensor On	20175	1732.5	18.73	19.50	1.194	-0.17	0.258	0.308
	LTE Band 4	20M	QPSK	1	0	Right Cheek	Bottom	P-Sensor On	20175	1732.5	19.68	20.50	1.208	0.1	0.08	0.097
	LTE Band 4	20M	QPSK	50	0	Right Cheek	Bottom	P-Sensor On	20175	1732.5	18.73	19.50	1.194	0.15	0.063	0.075
	LTE Band 4	20M	QPSK	1	0	Right Tilted	Bottom	P-Sensor On	20175	1732.5	19.68	20.50	1.208	0.08	0.039	0.047
	LTE Band 4	20M	QPSK	50	0	Right Tilted	Bottom	P-Sensor On	20175	1732.5	18.73	19.50	1.194	0.06	0.031	0.037
	LTE Band 4	20M	QPSK	1	0	Left Cheek	Bottom	P-Sensor On	20175	1732.5	19.68	20.50	1.208	-0.12	0.041	0.050
	LTE Band 4	20M	QPSK	50	0	Left Cheek	Bottom	P-Sensor On	20175	1732.5	18.73	19.50	1.194	-0.12	0.033	0.039
	LTE Band 4	20M	QPSK	1	0	Left Tilted	Bottom	P-Sensor On	20175	1732.5	19.68	20.50	1.208	-0.03	0.042	0.051
	LTE Band 4	20M	QPSK	50	0	Left Tilted	Bottom	P-Sensor On	20175	1732.5	18.73	19.50	1.194	-0.02	0.033	0.039
	LTE Band 7	20M	QPSK	1	99	Right Cheek	Top	P-Sensor On	21350	2560	19.84	20.50	1.164	0.01	0.586	0.682
	LTE Band 7	20M	QPSK	50	50	Right Cheek	Top	P-Sensor On	21350	2560	18.76	19.50	1.186	-0.07	0.477	0.566
08	LTE Band 7	20M	QPSK	1	99	Right Tilted	Top	P-Sensor On	21350	2560	19.84	20.50	1.164	-0.04	0.645	0.751
	LTE Band 7	20M	QPSK	1	99	Right Tilted	Top	P-Sensor On	21350(PCC + 21152(SCC))	2560(PCC) + SCC (2540.2)	19.82	20.50	1.169	-0.09	0.640	0.748
	LTE Band 7	20M	QPSK	50	50	Right Tilted	Top	P-Sensor On	21350	2560	18.76	19.50	1.186	-0.03	0.515	0.611
	LTE Band 7	20M	QPSK	1	99	Left Cheek	Top	P-Sensor On	21350	2560	19.84	20.50	1.164	-0.05	0.335	0.390
	LTE Band 7	20M	QPSK	50	50	Left Cheek	Top	P-Sensor On	21350	2560	18.76	19.50	1.186	-0.04	0.272	0.323
	LTE Band 7	20M	QPSK	1	99	Left Tilted	Top	P-Sensor On	21350	2560	19.84	20.50	1.164	-0.06	0.343	0.399
	LTE Band 7	20M	QPSK	50	50	Left Tilted	Top	P-Sensor On	21350	2560	18.76	19.50	1.186	-0.05	0.274	0.325
	LTE Band 7	20M	QPSK	1	99	Right Cheek	Bottom	P-Sensor On	21350	2560	19.84	20.50	1.164	-0.08	0.047	0.055
	LTE Band 7	20M	QPSK	50	50	Right Cheek	Bottom	P-Sensor On	21350	2560	18.76	19.50	1.186	-0.04	0.037	0.044
	LTE Band 7	20M	QPSK	1	99	Right Tilted	Bottom	P-Sensor On	21350	2560	19.84	20.50	1.164	0.13	0.058	0.068
	LTE Band 7	20M	QPSK	50	50	Right Tilted	Bottom	P-Sensor On	21350	2560	18.76	19.50	1.186	-0.01	0.048	0.057



	LTE Band 7	20M	QPSK	1	99	Left Cheek	Bottom	P-Sensor On	21350	2560	19.84	20.50	1.164	-0.08	0.089	0.104
	LTE Band 7	20M	QPSK	1	99	Left Cheek	Bottom	P-Sensor On	21350(PCC + 21152(SCC))	2560(PCC + SCC (2540.2))	19.82	20.50	1.169	-0.06	0.085	0.099
	LTE Band 7	20M	QPSK	50	50	Left Cheek	Bottom	P-Sensor On	21350	2560	18.76	19.50	1.186	-0.06	0.072	0.085
	LTE Band 7	20M	QPSK	1	99	Left Tilted	Bottom	P-Sensor On	21350	2560	19.84	20.50	1.164	-0.04	0.051	0.059
	LTE Band 7	20M	QPSK	50	50	Left Tilted	Bottom	P-Sensor On	21350	2560	18.76	19.50	1.186	-0.02	0.039	0.046

<TDD LTE SAR>

Plot No.	Band	BW (MHz)	Modulation	RB Size	RB Offset	Test Position	Antenna	Power Mode	Ch.	Freq. (MHz)	Average Power (dBm)	Tune-Up Limit (dBm)	Tune-up Scaling Factor	Duty Cycle %	Duty Cycle Scaling Factor	Power Drift (dB)	Measured 1g SAR (W/kg)	Reported 1g SAR (W/kg)
	LTE Band 38	20M	QPSK	1	49	Right Cheek	Top	P-Sensor On	38000	2595	20.48	22.00	1.419	62.9	1.006	0.02	0.397	0.567
	LTE Band 38	20M	QPSK	50	50	Right Cheek	Top	P-Sensor On	38000	2595	19.56	21.00	1.393	62.9	1.006	0.02	0.309	0.433
09	LTE Band 38	20M	QPSK	1	49	Right Tilted	Top	P-Sensor On	38000	2595	20.48	22.00	1.419	62.9	1.006	0.02	0.431	0.615
	LTE Band 38	20M	QPSK	1	49	Right Tilted	Top	P-Sensor On	37901(PCC) + 38099(SCC)	2585.1(PCC) + 2604.9(SCC)	20.66	22.00	1.361	62.9	1.006	-0.04	0.391	0.536
	LTE Band 38	20M	QPSK	50	50	Right Tilted	Top	P-Sensor On	38000	2595	19.56	21.00	1.393	62.9	1.006	-0.01	0.338	0.474
	LTE Band 38	20M	QPSK	1	49	Left Cheek	Top	P-Sensor On	38000	2595	20.48	22.00	1.419	62.9	1.006	-0.02	0.210	0.300
	LTE Band 38	20M	QPSK	50	50	Left Cheek	Top	P-Sensor On	38000	2595	19.56	21.00	1.393	62.9	1.006	-0.04	0.164	0.230
	LTE Band 38	20M	QPSK	1	49	Left Tilted	Top	P-Sensor On	38000	2595	20.48	22.00	1.419	62.9	1.006	-0.14	0.232	0.331
	LTE Band 38	20M	QPSK	50	50	Left Tilted	Top	P-Sensor On	38000	2595	19.56	21.00	1.393	62.9	1.006	-0.19	0.181	0.254
	LTE Band 38	20M	QPSK	1	49	Right Cheek	Bottom	P-Sensor On	38000	2595	20.48	22.00	1.419	62.9	1.006	-0.02	0.036	0.051
	LTE Band 38	20M	QPSK	50	50	Right Cheek	Bottom	P-Sensor On	38000	2595	19.56	21.00	1.393	62.9	1.006	-0.05	0.028	0.039
	LTE Band 38	20M	QPSK	1	49	Right Tilted	Bottom	P-Sensor On	38000	2595	20.48	22.00	1.419	62.9	1.006	-0.01	0.029	0.041
	LTE Band 38	20M	QPSK	50	50	Right Tilted	Bottom	P-Sensor On	38000	2595	19.56	21.00	1.393	62.9	1.006	-0.06	0.022	0.031
	LTE Band 38	20M	QPSK	1	49	Left Cheek	Bottom	P-Sensor On	38000	2595	20.48	22.00	1.419	62.9	1.006	-0.09	0.056	0.080
	LTE Band 38	20M	QPSK	1	49	Left Cheek	Bottom	P-Sensor On	37901(PCC) + 38099(SCC)	2585.1(PCC) + 2604.9(SCC)	20.66	22.00	1.361	62.9	1.006	-0.11	0.055	0.075
	LTE Band 38	20M	QPSK	50	50	Left Cheek	Bottom	P-Sensor On	38000	2595	19.56	21.00	1.393	62.9	1.006	-0.04	0.043	0.060
	LTE Band 38	20M	QPSK	1	49	Left Tilted	Bottom	P-Sensor On	38000	2595	20.48	22.00	1.419	62.9	1.006	-0.05	0.035	0.050
	LTE Band 38	20M	QPSK	50	50	Left Tilted	Bottom	P-Sensor On	38000	2595	19.56	21.00	1.393	62.9	1.006	-0.05	0.035	0.049

<WLAN2.4GHz SAR>

Plot No.	Band	Mode	Test Position	Ch.	Freq. (MHz)	Average Power (dBm)	Tune-Up Limit (dBm)	Tune-up Scaling Factor	Duty Cycle %	Duty Cycle Scaling Factor	Max Area Scan SAR	Power Drift (dB)	Measured 1g SAR (W/kg)	Reported 1g SAR (W/kg)
	WLAN2.4GHz	802.11b 1Mbps	Right Cheek	11	2462	17.05	18.50	1.396	100	1.000	0.221			
	WLAN2.4GHz	802.11b 1Mbps	Right Tilted	11	2462	17.05	18.50	1.396	100	1.000	0.232			
10	WLAN2.4GHz	802.11b 1Mbps	Left Cheek	11	2462	17.05	18.50	1.396	100	1.000	0.803	0.06	0.463	0.647
	WLAN2.4GHz	802.11b 1Mbps	Left Tilted	11	2462	17.05	18.50	1.396	100	1.000	0.786	0.11	0.451	0.630



<WLAN5GHz SAR>

Plot No.	Band	Mode	Test Position	Ch.	Freq. (MHz)	Average Power (dBm)	Tune-Up Limit (dBm)	Tune-up Scaling Factor	Duty Cycle %	Duty Cycle Scaling Factor	Max Area Scan SAR	Power Drift (dB)	Measured 1g SAR (W/kg)	Reported 1g SAR (W/kg)
	WLAN5.3GHz	802.11a 6Mbps	Right Cheek	52	5260	16.27	16.50	1.054	95	1.053	0.568			
	WLAN5.3GHz	802.11a 6Mbps	Right Tilted	52	5260	16.27	16.50	1.054	95	1.053	0.678			
	WLAN5.3GHz	802.11a 6Mbps	Left Cheek	52	5260	16.27	16.50	1.054	95	1.053	0.841	0.04	0.435	0.483
11	WLAN5.3GHz	802.11a 6Mbps	Left Tilted	52	5260	16.27	16.50	1.054	95	1.053	1.226	0.04	0.651	0.723
	WLAN5.5GHz	802.11a 6Mbps	Right Cheek	100	5500	15.88	16.50	1.153	95	1.053	0.880			
	WLAN5.5GHz	802.11a 6Mbps	Right Tilted	100	5500	15.88	16.50	1.153	95	1.053	0.798			
	WLAN5.5GHz	802.11a 6Mbps	Left Cheek	100	5500	15.88	16.50	1.153	95	1.053	0.896	-0.08	0.422	0.513
12	WLAN5.5GHz	802.11a 6Mbps	Left Tilted	100	5500	15.88	16.50	1.153	95	1.053	0.979	-0.05	0.469	0.570
	WLAN 5.8GHz	802.11a 6Mbps	Right Cheek	161	5805	15.34	16.5	1.306	95	1.053	0.517			
	WLAN 5.8GHz	802.11a 6Mbps	Right Tilted	161	5805	15.34	16.5	1.306	95	1.053	0.395			
	WLAN 5.8GHz	802.11a 6Mbps	Left Cheek	161	5805	15.34	16.5	1.306	95	1.053	0.809	0.1	0.278	0.382
13	WLAN 5.8GHz	802.11a 6Mbps	Left Tilted	161	5805	15.34	16.5	1.306	95	1.053	0.783	-0.05	0.303	0.417

<Bluetooth SAR>

Plot No.	Band	Mode	Test Position	Ch.	Freq. (MHz)	Average Power (dBm)	Tune-Up Limit (dBm)	Tune-up Scaling Factor	Duty Cycle %	Duty Cycle Scaling Factor	Power Drift (dB)	Measured 1g SAR (W/kg)	Reported 1g SAR (W/kg)
	Bluetooth	1Mbps	Left Cheek	0	2402	8.82	10.00	1.312	76.63	1.087	-0.01	0.054	0.077
14	Bluetooth	1Mbps	Left Cheek	39	2441	8.61	10.00	1.377	76.63	1.087	-0.09	0.056	0.084
	Bluetooth	1Mbps	Left Cheek	78	2480	8.87	10.00	1.297	76.63	1.087	0.02	0.057	0.080



15.2 Hotspot SAR

<GSM SAR>

Plot No.	Band	Mode	Test Position	Gap (mm)	Antenna	Power Mode	Ch.	Freq. (MHz)	Average Power (dBm)	Tune-Up Limit (dBm)	Tune-up Scaling Factor	Power Drift (dB)	Measured 1g SAR (W/kg)	Reported 1g SAR (W/kg)
	GSM850	GPRS (4 Tx slots)	Front	10	Top	P-Sensor Off	251	848.8	29.04	30.00	1.247	-0.05	0.075	0.094
	GSM850	GPRS (4 Tx slots)	Back	10	Top	P-Sensor Off	251	848.8	29.04	30.00	1.247	-0.1	0.129	0.161
	GSM850	GPRS (4 Tx slots)	Left Side	10	Top	P-Sensor Off	251	848.8	29.04	30.00	1.247	-0.05	0.063	0.079
	GSM850	GPRS (4 Tx slots)	Top Side	10	Top	P-Sensor Off	251	848.8	29.04	30.00	1.247	0.01	0.099	0.123
	GSM850	GPRS (4 Tx slots)	Front	10	Bottom	P-Sensor Off	251	848.8	29.04	30.00	1.247	-0.09	0.108	0.135
15	GSM850	GPRS (4 Tx slots)	Back	10	Bottom	P-Sensor Off	251	848.8	29.04	30.00	1.247	-0.04	0.182	0.227
	GSM850	GPRS (4 Tx slots)	Left Side	10	Bottom	P-Sensor Off	251	848.8	29.04	30.00	1.247	-0.07	0.101	0.126
	GSM850	GPRS (4 Tx slots)	Right Side	10	Bottom	P-Sensor Off	251	848.8	29.04	30.00	1.247	0.01	0.102	0.127
	GSM850	GPRS (4 Tx slots)	Bottom Side	10	Bottom	P-Sensor Off	251	848.8	29.04	30.00	1.247	-0.08	0.053	0.066
	GSM1900	GPRS (4 Tx slots)	Front	10	Top	P-Sensor On	512	1850.2	23.08	23.50	1.102	0.01	0.081	0.089
	GSM1900	GPRS (4 Tx slots)	Back	10	Top	P-Sensor On	512	1850.2	23.08	23.50	1.102	0.07	0.124	0.137
	GSM1900	GPRS (4 Tx slots)	Left Side	10	Top	P-Sensor Off	512	1850.2	23.08	23.50	1.102	-0.03	0.051	0.056
	GSM1900	GPRS (4 Tx slots)	Top Side	10	Top	P-Sensor On	512	1850.2	23.08	23.50	1.102	-0.09	0.142	0.156
	GSM1900	GPRS (4 Tx slots)	Front	10	Bottom	P-Sensor On	512	1850.2	23.08	23.50	1.102	0.03	0.176	0.194
	GSM1900	GPRS (4 Tx slots)	Back	10	Bottom	P-Sensor On	512	1850.2	23.08	23.50	1.102	-0.02	0.423	0.466
	GSM1900	GPRS (4 Tx slots)	Left Side	10	Bottom	P-Sensor Off	512	1850.2	23.08	23.50	1.102	0.09	0.010	0.011
	GSM1900	GPRS (4 Tx slots)	Right Side	10	Bottom	P-Sensor Off	512	1850.2	23.08	23.50	1.102	0.06	0.034	0.037
16	GSM1900	GPRS (4 Tx slots)	Bottom Side	10	Bottom	P-Sensor On	512	1850.2	23.08	23.50	1.102	-0.01	0.512	0.564



<WCDMA SAR>

Plot No.	Band	Mode	Test Position	Gap (mm)	Antenna	Power Mode	Ch.	Freq. (MHz)	Average Power (dBm)	Tune-Up Limit (dBm)	Tune-up Scaling Factor	Power Drift (dB)	Measured 1g SAR (W/kg)	Reported 1g SAR (W/kg)
	WCDMA Band V	RMC 12.2Kbps	Front	10	Top	P-Sensor Off	4233	846.6	23.58	24	1.102	-0.19	0.048	0.053
	WCDMA Band V	RMC 12.2Kbps	Back	10	Top	P-Sensor Off	4233	846.6	23.58	24	1.102	-0.04	0.102	0.112
	WCDMA Band V	RMC 12.2Kbps	Left Side	10	Top	P-Sensor Off	4233	846.6	23.58	24	1.102	-0.04	0.036	0.040
	WCDMA Band V	RMC 12.2Kbps	Top Side	10	Top	P-Sensor Off	4233	846.6	23.58	24	1.102	-0.04	0.070	0.077
	WCDMA Band V	RMC 12.2Kbps	Front	10	Bottom	P-Sensor Off	4233	846.6	23.58	24	1.102	-0.01	0.082	0.090
17	WCDMA Band V	RMC 12.2Kbps	Back	10	Bottom	P-Sensor Off	4233	846.6	23.58	24	1.102	0.02	0.118	0.130
	WCDMA Band V	RMC 12.2Kbps	Left Side	10	Bottom	P-Sensor Off	4233	846.6	23.58	24	1.102	-0.09	0.069	0.076
	WCDMA Band V	RMC 12.2Kbps	Right Side	10	Bottom	P-Sensor Off	4233	846.6	23.58	24	1.102	-0.03	0.077	0.085
	WCDMA Band V	RMC 12.2Kbps	Bottom Side	10	Bottom	P-Sensor Off	4233	846.6	23.58	24	1.102	-0.07	0.030	0.033
	WCDMA Band IV	RMC 12.2Kbps	Front	10	Top	P-Sensor On	1413	1732.6	20.28	21.50	1.324	0.11	0.129	0.171
	WCDMA Band IV	RMC 12.2Kbps	Back	10	Top	P-Sensor On	1413	1732.6	20.28	21.50	1.324	-0.03	0.176	0.233
	WCDMA Band IV	RMC 12.2Kbps	Left Side	10	Top	P-Sensor Off	1413	1732.6	24.59	25.00	1.099	-0.13	0.050	0.055
	WCDMA Band IV	RMC 12.2Kbps	Top Side	10	Top	P-Sensor On	1413	1732.6	20.28	21.50	1.324	-0.17	0.200	0.265
	WCDMA Band IV	RMC 12.2Kbps	Front	10	Bottom	P-Sensor On	1413	1732.6	20.28	21.50	1.324	-0.02	0.254	0.336
	WCDMA Band IV	RMC 12.2Kbps	Back	10	Bottom	P-Sensor On	1413	1732.6	20.28	21.50	1.324	-0.01	0.585	0.775
	WCDMA Band IV	RMC 12.2Kbps	Left Side	10	Bottom	P-Sensor Off	1413	1732.6	24.59	25.00	1.099	-0.03	0.011	0.012
	WCDMA Band IV	RMC 12.2Kbps	Right Side	10	Bottom	P-Sensor Off	1413	1732.6	24.59	25.00	1.099	-0.04	0.088	0.097
	WCDMA Band IV	RMC 12.2Kbps	Bottom Side	10	Bottom	P-Sensor On	1413	1732.6	20.28	21.50	1.324	0.06	0.685	0.907
18	WCDMA Band IV	RMC 12.2Kbps	Bottom Side	10	Bottom	P-Sensor On	1312	1712.4	20.08	21.50	1.387	-0.14	0.820	1.137
	WCDMA Band IV	RMC 12.2Kbps	Bottom Side	10	Bottom	P-Sensor On	1513	1752.6	20.23	21.50	1.340	0.06	0.645	0.864
	WCDMA Band II	RMC 12.2Kbps	Front	10	Top	P-Sensor On	9262	1852.4	20.10	20.50	1.096	0.16	0.157	0.172
	WCDMA Band II	RMC 12.2Kbps	Back	10	Top	P-Sensor On	9262	1852.4	20.10	20.50	1.096	-0.15	0.226	0.248
	WCDMA Band II	RMC 12.2Kbps	Left Side	10	Top	P-Sensor Off	9262	1852.4	23.41	24.00	1.146	-0.11	0.084	0.096
	WCDMA Band II	RMC 12.2Kbps	Top Side	10	Top	P-Sensor On	9262	1852.4	20.10	20.50	1.096	-0.08	0.252	0.276
	WCDMA Band II	RMC 12.2Kbps	Front	10	Bottom	P-Sensor On	9262	1852.4	20.10	20.50	1.096	-0.01	0.179	0.196
	WCDMA Band II	RMC 12.2Kbps	Back	10	Bottom	P-Sensor On	9262	1852.4	20.10	20.50	1.096	-0.04	0.430	0.471
	WCDMA Band II	RMC 12.2Kbps	Left Side	10	Bottom	P-Sensor Off	9262	1852.4	23.41	24.00	1.146	-0.01	0.009	0.010
	WCDMA Band II	RMC 12.2Kbps	Right Side	10	Bottom	P-Sensor Off	9262	1852.4	23.41	24.00	1.146	-0.01	0.028	0.032
19	WCDMA Band II	RMC 12.2Kbps	Bottom Side	10	Bottom	P-Sensor On	9262	1852.4	20.10	20.50	1.096	-0.02	0.514	0.564



<FDD LTE SAR>

Plot No.	Band	BW (MHz)	Modulation	RB Size	RB Offset	Test Position	Gap (mm)	Antenna	Power Mode	Ch.	Freq. (MHz)	Average Power (dBm)	Tune-Up Limit (dBm)	Tune-up Scaling Factor	Power Drift (dB)	Measured 1g SAR (W/kg)	Reported 1g SAR (W/kg)
	LTE Band 5	10M	QPSK	1	0	Front	10	Top	P-Sensor Off	20525	836.5	22.90	24.00	1.288	-0.12	0.050	0.064
	LTE Band 5	10M	QPSK	25	12	Front	10	Top	P-Sensor Off	20525	836.5	21.96	23.00	1.271	0.01	0.039	0.050
	LTE Band 5	10M	QPSK	1	0	Back	10	Top	P-Sensor Off	20525	836.5	22.90	24.00	1.288	0.04	0.084	0.108
	LTE Band 5	10M	QPSK	25	12	Back	10	Top	P-Sensor Off	20525	836.5	21.96	23.00	1.271	-0.08	0.062	0.079
	LTE Band 5	10M	QPSK	1	0	Left Side	10	Top	P-Sensor Off	20525	836.5	22.90	24.00	1.288	-0.14	0.037	0.048
	LTE Band 5	10M	QPSK	25	12	Left Side	10	Top	P-Sensor Off	20525	836.5	21.96	23.00	1.271	-0.05	0.030	0.038
	LTE Band 5	10M	QPSK	1	0	Top Side	10	Top	P-Sensor Off	20525	836.5	22.90	24.00	1.288	-0.06	0.060	0.077
	LTE Band 5	10M	QPSK	25	12	Top Side	10	Top	P-Sensor Off	20525	836.5	21.96	23.00	1.271	-0.09	0.049	0.062
	LTE Band 5	10M	QPSK	1	0	Front	10	Bottom	P-Sensor Off	20525	836.5	22.90	24.00	1.288	-0.12	0.074	0.095
	LTE Band 5	10M	QPSK	25	12	Front	10	Bottom	P-Sensor Off	20525	836.5	21.96	23.00	1.271	-0.01	0.061	0.078
20	LTE Band 5	10M	QPSK	1	0	Back	10	Bottom	P-Sensor Off	20525	836.5	22.90	24.00	1.288	-0.05	0.119	0.153
	LTE Band 5	10M	QPSK	25	12	Back	10	Bottom	P-Sensor Off	20525	836.5	21.96	23.00	1.271	-0.03	0.082	0.104
	LTE Band 5	10M	QPSK	1	0	Left Side	10	Bottom	P-Sensor Off	20525	836.5	22.90	24.00	1.288	-0.03	0.064	0.082
	LTE Band 5	10M	QPSK	25	12	Left Side	10	Bottom	P-Sensor Off	20525	836.5	21.96	23.00	1.271	-0.07	0.052	0.066
	LTE Band 5	10M	QPSK	1	0	Right Side	10	Bottom	P-Sensor Off	20525	836.5	22.90	24.00	1.288	0.08	0.067	0.086
	LTE Band 5	10M	QPSK	25	12	Right Side	10	Bottom	P-Sensor Off	20525	836.5	21.96	23.00	1.271	-0.06	0.057	0.072
	LTE Band 5	10M	QPSK	1	0	Bottom Side	10	Bottom	P-Sensor Off	20525	836.5	22.90	24.00	1.288	-0.15	0.023	0.030
	LTE Band 5	10M	QPSK	25	12	Bottom Side	10	Bottom	P-Sensor Off	20525	836.5	21.96	23.00	1.271	-0.19	0.019	0.024
	LTE Band 4	20M	QPSK	1	0	Front	10	Top	P-Sensor On	20175	1732.5	19.68	20.50	1.208	0.12	0.118	0.143
	LTE Band 4	20M	QPSK	50	0	Front	10	Top	P-Sensor On	20175	1732.5	18.73	19.50	1.194	0.13	0.095	0.113
	LTE Band 4	20M	QPSK	1	0	Back	10	Top	P-Sensor On	20175	1732.5	19.68	20.50	1.208	0.08	0.166	0.200
	LTE Band 4	20M	QPSK	50	0	Back	10	Top	P-Sensor On	20175	1732.5	18.73	19.50	1.194	-0.15	0.136	0.162
	LTE Band 4	20M	QPSK	1	0	Left Side	10	Top	P-Sensor Off	20175	1732.5	23.06	24.00	1.242	-0.08	0.045	0.056
	LTE Band 4	20M	QPSK	50	0	Left Side	10	Top	P-Sensor Off	20175	1732.5	22.09	23.00	1.233	-0.03	0.036	0.044
	LTE Band 4	20M	QPSK	1	0	Top Side	10	Top	P-Sensor On	20175	1732.5	19.68	20.50	1.208	-0.15	0.188	0.227
	LTE Band 4	20M	QPSK	50	0	Top Side	10	Top	P-Sensor On	20175	1732.5	18.73	19.50	1.194	-0.17	0.155	0.185
	LTE Band 4	20M	QPSK	1	0	Front	10	Bottom	P-Sensor On	20175	1732.5	19.68	20.50	1.208	-0.04	0.245	0.296
	LTE Band 4	20M	QPSK	50	0	Front	10	Bottom	P-Sensor On	20175	1732.5	18.73	19.50	1.194	-0.05	0.191	0.228
	LTE Band 4	20M	QPSK	1	0	Back	10	Bottom	P-Sensor On	20175	1732.5	19.68	20.50	1.208	0.01	0.591	0.714
	LTE Band 4	20M	QPSK	50	0	Back	10	Bottom	P-Sensor On	20175	1732.5	18.73	19.50	1.194	-0.03	0.460	0.549
	LTE Band 4	20M	QPSK	1	0	Left Side	10	Bottom	P-Sensor Off	20175	1732.5	23.06	24.00	1.242	-0.04	0.010	0.012
	LTE Band 4	20M	QPSK	50	0	Left Side	10	Bottom	P-Sensor Off	20175	1732.5	22.09	23.00	1.233	-0.03	0.006	0.007
	LTE Band 4	20M	QPSK	1	0	Right Side	10	Bottom	P-Sensor Off	20175	1732.5	23.06	24.00	1.242	-0.12	0.088	0.109
	LTE Band 4	20M	QPSK	50	0	Right Side	10	Bottom	P-Sensor Off	20175	1732.5	22.09	23.00	1.233	-0.02	0.073	0.090
21	LTE Band 4	20M	QPSK	1	0	Bottom Side	10	Bottom	P-Sensor On	20175	1732.5	19.68	20.50	1.208	-0.03	0.736	0.889
	LTE Band 4	20M	QPSK	50	0	Bottom Side	10	Bottom	P-Sensor On	20175	1732.5	18.73	19.50	1.194	0.07	0.528	0.630
	LTE Band 4	20M	QPSK	100	0	Bottom Side	10	Bottom	P-Sensor On	20175	1732.5	18.69	19.50	1.205	-0.08	0.485	0.584
	LTE Band 7	20M	QPSK	1	99	Front	10	Top	P-Sensor On	21350	2560	19.84	20.50	1.164	-0.04	0.069	0.080
	LTE Band 7	20M	QPSK	50	50	Front	10	Top	P-Sensor On	21350	2560	18.76	19.50	1.186	-0.09	0.061	0.072
	LTE Band 7	20M	QPSK	1	99	Back	10	Top	P-Sensor On	21350	2560	19.84	20.50	1.164	-0.01	0.166	0.193
	LTE Band 7	20M	QPSK	1	99	Back	10	Top	P-Sensor On	21350(PCC) + 21152(SCC)	2560(PCC) + 2540.2(SCC)	19.82	20.50	1.169	0.05	0.141	0.165
	LTE Band 7	20M	QPSK	50	50	Back	10	Top	P-Sensor On	21350	2560	18.76	19.50	1.186	-0.03	0.134	0.159
	LTE Band 7	20M	QPSK	1	99	Left Side	10	Top	P-Sensor Off	21350	2560	22.88	24.00	1.294	-0.02	0.015	0.019
	LTE Band 7	20M	QPSK	50	50	Left Side	10	Top	P-Sensor Off	21350	2560	21.87	23.00	1.297	-0.02	0.013	0.017
	LTE Band 7	20M	QPSK	1	99	Top Side	10	Top	P-Sensor On	21350	2560	19.84	20.50	1.164	-0.12	0.161	0.187
	LTE Band 7	20M	QPSK	50	50	Top Side	10	Top	P-Sensor On	21350	2560	18.76	19.50	1.186	-0.04	0.130	0.154
	LTE Band 7	20M	QPSK	1	99	Front	10	Bottom	P-Sensor On	21350	2560	19.84	20.50	1.164	-0.08	0.123	0.143
	LTE Band 7	20M	QPSK	50	50	Front	10	Bottom	P-Sensor On	21350	2560	18.76	19.50	1.186	-0.04	0.096	0.114
	LTE Band 7	20M	QPSK	1	99	Back	10	Bottom	P-Sensor On	21350	2560	19.84	20.50	1.164	-0.02	0.13	0.151
	LTE Band 7	20M	QPSK	1	99	Back	10	Bottom	P-Sensor On	21350(PCC) + 21152(SCC)	2560(PCC) + 2540.2(SCC)	19.82	20.50	1.169	-0.08	0.106	0.124



	LTE Band 7	20M	QPSK	50	50	Back	10	Bottom	P-Sensor On	21350	2560	18.76	19.50	1.186	-0.05	0.102	0.121
	LTE Band 7	20M	QPSK	1	99	Left Side	10	Bottom	P-Sensor Off	21350	2560	22.88	24.00	1.294	-0.09	0.069	0.089
	LTE Band 7	20M	QPSK	50	50	Left Side	10	Bottom	P-Sensor Off	21350	2560	21.87	23.00	1.297	-0.09	0.058	0.075
	LTE Band 7	20M	QPSK	1	99	Right Side	10	Bottom	P-Sensor Off	21350	2560	22.88	24.00	1.294	-0.14	0.077	0.100
	LTE Band 7	20M	QPSK	50	50	Right Side	10	Bottom	P-Sensor Off	21350	2560	21.87	23.00	1.297	-0.01	0.065	0.084
22	LTE Band 7	20M	QPSK	1	99	Bottom Side	10	Bottom	P-Sensor On	21350	2560	19.84	20.50	1.164	-0.14	0.203	0.236
	LTE Band 7	20M	QPSK	1	99	Bottom Side	10	Bottom	P-Sensor On	21350(PCC) + 21152(SCC)	2560(PCC) + 2540.2(SCC)	19.82	20.50	1.169	-0.05	0.154	0.180
	LTE Band 7	20M	QPSK	50	50	Bottom Side	10	Bottom	P-Sensor On	21350	2560	18.76	19.50	1.186	-0.15	0.159	0.189

<TDD LTE SAR>

Plot No.	Band	BW (MHz)	Modulation	RB Size	RB Offset	Test Position	Gap (mm)	Antenna	Power Mode	Ch.	Freq. (MHz)	Average Power (dBm)	Tune-Up Limit (dBm)	Tune-up Scaling Factor	Duty Cycle %	Duty Cycle Scaling Factor	Power Drift (dB)	Measured 1g SAR (W/kg)	Reported 1g SAR (W/kg)
	LTE Band 38	20M	QPSK	1	49	Front	10	Top	P-Sensor On	38000	2595	20.48	22.00	1.419	62.9	1.006	-0.09	0.051	0.073
	LTE Band 38	20M	QPSK	50	50	Front	10	Top	P-Sensor On	38000	2595	19.56	21.00	1.393	62.9	1.006	-0.03	0.038	0.054
	LTE Band 38	20M	QPSK	1	49	Back	10	Top	P-Sensor On	38000	2595	20.48	22.00	1.419	62.9	1.006	-0.03	0.098	0.140
	LTE Band 38	20M	QPSK	1	49	Back	10	Top	P-Sensor On	37901(PCC) + 38099(SCC)	2585.1(PCC) + 2604.9(SCC)	20.66	22.00	1.361	62.9	1.006	-0.02	0.095	0.130
	LTE Band 38	20M	QPSK	50	50	Back	10	Top	P-Sensor On	38000	2595	19.56	21.00	1.393	62.9	1.006	-0.08	0.083	0.116
	LTE Band 38	20M	QPSK	1	49	Left Side	10	Top	P-Sensor Off	38000	2595	22.79	24.30	1.416	62.9	1.006	-0.06	0.009	0.013
	LTE Band 38	20M	QPSK	50	50	Left Side	10	Top	P-Sensor Off	38000	2595	21.81	23.30	1.409	62.9	1.006	-0.05	0.004	0.006
	LTE Band 38	20M	QPSK	1	49	Top Side	10	Top	P-Sensor On	38000	2595	20.48	22.00	1.419	62.9	1.006	0.04	0.103	0.147
	LTE Band 38	20M	QPSK	1	49	Top Side	10	Top	P-Sensor On	37901(PCC) + 38099(SCC)	2585.1(PCC) + 2604.9(SCC)	20.66	22.00	1.361	62.9	1.006	0.01	0.098	0.134
	LTE Band 38	20M	QPSK	50	50	Top Side	10	Top	P-Sensor On	38000	2595	19.56	21.00	1.393	62.9	1.006	-0.07	0.092	0.129
	LTE Band 38	20M	QPSK	1	49	Front	10	Bottom	P-Sensor On	38000	2595	20.48	22.00	1.419	62.9	1.006	-0.07	0.095	0.135
	LTE Band 38	20M	QPSK	50	50	Front	10	Bottom	P-Sensor On	38000	2595	19.56	21.00	1.393	62.9	1.006	-0.08	0.076	0.107
	LTE Band 38	20M	QPSK	1	49	Back	10	Bottom	P-Sensor On	38000	2595	20.48	22.00	1.419	62.9	1.006	0.03	0.099	0.141
	LTE Band 38	20M	QPSK	1	49	Back	10	Bottom	P-Sensor On	37901(PCC) + 38099(SCC)	2585.1(PCC) + 2604.9(SCC)	20.66	22.00	1.361	62.9	1.006	0.05	0.085	0.116
	LTE Band 38	20M	QPSK	50	50	Back	10	Bottom	P-Sensor On	38000	2595	19.56	21.00	1.393	62.9	1.006	-0.09	0.078	0.109
	LTE Band 38	20M	QPSK	1	49	Left Side	10	Bottom	P-Sensor Off	38000	2595	22.79	24.30	1.416	62.9	1.006	-0.05	0.075	0.107
	LTE Band 38	20M	QPSK	50	50	Left Side	10	Bottom	P-Sensor Off	38000	2595	21.81	23.30	1.409	62.9	1.006	-0.16	0.060	0.085
	LTE Band 38	20M	QPSK	1	49	Right Side	10	Bottom	P-Sensor Off	38000	2595	22.79	24.30	1.416	62.9	1.006	-0.08	0.055	0.078
	LTE Band 38	20M	QPSK	50	50	Right Side	10	Bottom	P-Sensor Off	38000	2595	21.81	23.30	1.409	62.9	1.006	-0.06	0.044	0.062
23	LTE Band 38	20M	QPSK	1	49	Bottom Side	10	Bottom	P-Sensor On	38000	2595	20.48	22.00	1.419	62.9	1.006	-0.1	0.157	0.224
	LTE Band 38	20M	QPSK	1	49	Bottom Side	10	Bottom	P-Sensor On	37901(PCC) + 38099(SCC)	2585.1(PCC) + 2604.9(SCC)	20.66	22.00	1.361	62.9	1.006	0.07	0.149	0.204
	LTE Band 38	20M	QPSK	50	50	Bottom Side	10	Bottom	P-Sensor On	38000	2595	19.56	21.00	1.393	62.9	1.006	-0.04	0.127	0.178



<WLAN 2.4GHz SAR>

Plot No.	Band	Mode	Test Position	Gap (mm)	Ch.	Freq. (MHz)	Average Power (dBm)	Tune-Up Limit (dBm)	Tune-up Scaling Factor	Duty Cycle %	Duty Cycle Scaling Factor	Max Area Scan SAR	Power Drift (dB)	Measured 1g SAR (W/kg)	Reported 1g SAR (W/kg)
	WLAN 2.4GHz	802.11b 1Mbps	Front	10	11	2462	17.05	18.5	1.396	100	1.000	0.131			
24	WLAN 2.4GHz	802.11b 1Mbps	Back	10	11	2462	17.05	18.5	1.396	100	1.000	0.236	0.03	0.151	0.211
	WLAN 2.4GHz	802.11b 1Mbps	Right Side	10	11	2462	17.05	18.5	1.396	100	1.000	0.166			
	WLAN 2.4GHz	802.11b 1Mbps	Top Side	10	11	2462	17.05	18.5	1.396	100	1.000	0.075			

<WLAN 5GHz SAR>

Plot No.	Band	Mode	Test Position	Gap (mm)	Ch.	Freq. (MHz)	Average Power (dBm)	Tune-Up Limit (dBm)	Tune-up Scaling Factor	Duty Cycle %	Duty Cycle Scaling Factor	Max Area Scan SAR	Power Drift (dB)	Measured 1g SAR (W/kg)	Reported 1g SAR (W/kg)
	WLAN5.2GHz	802.11a 6Mbps	Front	10	48	5240	16.25	16.5	1.059	95	1.053	0.190			
	WLAN5.2GHz	802.11a 6Mbps	Back	10	48	5240	16.25	16.5	1.059	95	1.053	0.505	-0.03	0.201	0.224
	WLAN5.2GHz	802.11a 6Mbps	Right Side	10	48	5240	16.25	16.5	1.059	95	1.053	0.169			
25	WLAN5.2GHz	802.11a 6Mbps	Top Side	10	48	5240	16.25	16.5	1.059	95	1.053	0.571	0.16	0.261	0.291
	WLAN5.8GHz	802.11a 6Mbps	Front	10	161	5805	15.34	16.5	1.306	95	1.053	0.154			
26	WLAN5.8GHz	802.11a 6Mbps	Back	10	161	5805	15.34	16.5	1.306	95	1.053	0.280	-0.09	0.092	0.127
	WLAN5.8GHz	802.11a 6Mbps	Right Side	10	161	5805	15.34	16.5	1.306	95	1.053	0.132			
	WLAN5.8GHz	802.11a 6Mbps	Top Side	10	161	5805	15.34	16.5	1.306	95	1.053	0.274			

<Bluetooth SAR>

Plot No.	Band	Mode	Test Position	Gap (mm)	Ch.	Freq. (MHz)	Average Power (dBm)	Tune-Up Limit (dBm)	Tune-up Scaling Factor	Duty Cycle %	Duty Cycle Scaling Factor	Power Drift (dB)	Measured 1g SAR (W/kg)	Reported 1g SAR (W/kg)
	Bluetooth	1Mbps	Front	10	78	2480	8.87	10	1.297	76.63	1.087	0.02	0.010	0.014
27	Bluetooth	1Mbps	Back	10	78	2480	8.87	10	1.297	76.63	1.087	-0.03	0.021	0.030
	Bluetooth	1Mbps	Right Side	10	78	2480	8.87	10	1.297	76.63	1.087	-0.07	0.008	0.012
	Bluetooth	1Mbps	Top Side	10	78	2480	8.87	10	1.297	76.63	1.087	0.05	0.003	0.004



15.3 Body Worn Accessory SAR

<GSM SAR>

Plot No.	Band	Mode	Test Position	Gap (mm)	Antenna	Power Mode	Ch.	Freq. (MHz)	Average Power (dBm)	Tune-Up Limit (dBm)	Tune-up Scaling Factor	Power Drift (dB)	Measured 1g SAR (W/kg)	Reported 1g SAR (W/kg)
	GSM850	GPRS (4 Tx slots)	Front	10	Top	P-Sensor Off	251	848.8	29.04	30.00	1.247	-0.05	0.075	0.094
	GSM850	GPRS (4 Tx slots)	Back	10	Top	P-Sensor Off	251	848.8	29.04	30.00	1.247	-0.1	0.129	0.161
	GSM850	GPRS (4 Tx slots)	Front	10	Bottom	P-Sensor Off	251	848.8	29.04	30.00	1.247	-0.09	0.108	0.135
28	GSM850	GPRS (4 Tx slots)	Back	10	Bottom	P-Sensor Off	251	848.8	29.04	30.00	1.247	-0.04	0.182	0.227
	GSM1900	GPRS (4 Tx slots)	Front	10	Top	P-Sensor On	512	1850.2	23.08	23.50	1.102	0.01	0.081	0.089
	GSM1900	GPRS (4 Tx slots)	Back	10	Top	P-Sensor On	512	1850.2	23.08	23.50	1.102	0.07	0.124	0.137
	GSM1900	GPRS (4 Tx slots)	Front	10	Bottom	P-Sensor On	512	1850.2	23.08	23.50	1.102	0.03	0.176	0.194
29	GSM1900	GPRS (4 Tx slots)	Back	10	Bottom	P-Sensor On	512	1850.2	23.08	23.50	1.102	-0.02	0.423	0.466

<WCDMA SAR>

Plot No.	Band	Mode	Test Position	Gap (mm)	Antenna	Power Mode	Ch.	Freq. (MHz)	Average Power (dBm)	Tune-Up Limit (dBm)	Tune-up Scaling Factor	Power Drift (dB)	Measured 1g SAR (W/kg)	Reported 1g SAR (W/kg)
	WCDMA Band V	RMC 12.2Kbps	Front	10	Top	P-Sensor Off	4233	846.6	23.58	24	1.102	-0.19	0.048	0.053
	WCDMA Band V	RMC 12.2Kbps	Back	10	Top	P-Sensor Off	4233	846.6	23.58	24	1.102	-0.04	0.102	0.112
	WCDMA Band V	RMC 12.2Kbps	Front	10	Bottom	P-Sensor Off	4233	846.6	23.58	24	1.102	-0.01	0.082	0.090
30	WCDMA Band V	RMC 12.2Kbps	Back	10	Bottom	P-Sensor Off	4233	846.6	23.58	24	1.102	0.02	0.118	0.130
	WCDMA Band IV	RMC 12.2Kbps	Front	10	Top	P-Sensor On	1413	1732.6	20.28	21.50	1.324	0.11	0.129	0.171
	WCDMA Band IV	RMC 12.2Kbps	Back	10	Top	P-Sensor On	1413	1732.6	20.28	21.50	1.324	-0.03	0.176	0.233
	WCDMA Band IV	RMC 12.2Kbps	Front	10	Bottom	P-Sensor On	1413	1732.6	20.28	21.50	1.324	-0.02	0.254	0.336
31	WCDMA Band IV	RMC 12.2Kbps	Back	10	Bottom	P-Sensor On	1413	1732.6	20.28	21.50	1.324	-0.01	0.585	0.775
	WCDMA Band II	RMC 12.2Kbps	Front	10	Top	P-Sensor On	9262	1852.4	20.10	20.50	1.096	0.16	0.157	0.172
	WCDMA Band II	RMC 12.2Kbps	Back	10	Top	P-Sensor On	9262	1852.4	20.10	20.50	1.096	-0.15	0.226	0.248
	WCDMA Band II	RMC 12.2Kbps	Front	10	Bottom	P-Sensor On	9262	1852.4	20.10	20.50	1.096	-0.01	0.179	0.196
32	WCDMA Band II	RMC 12.2Kbps	Back	10	Bottom	P-Sensor On	9262	1852.4	20.10	20.50	1.096	-0.04	0.430	0.471



<FDD LTE SAR>

Plot No.	Band	BW (MHz)	Modulation	RB Size	RB Offset	Test Position	Gap (mm)	Antenna	Power Mode	Ch.	Freq. (MHz)	Average Power (dBm)	Tune-Up Limit (dBm)	Tune-up Scaling Factor	Power Drift (dB)	Measured 1g SAR (W/kg)	Reported 1g SAR (W/kg)
	LTE Band 5	10M	QPSK	1	0	Front	10	Top	P-Sensor Off	20525	836.5	22.90	24.00	1.288	-0.12	0.050	0.064
	LTE Band 5	10M	QPSK	25	12	Front	10	Top	P-Sensor Off	20525	836.5	21.96	23.00	1.271	0.01	0.039	0.050
	LTE Band 5	10M	QPSK	1	0	Back	10	Top	P-Sensor Off	20525	836.5	22.90	24.00	1.288	0.04	0.084	0.108
	LTE Band 5	10M	QPSK	25	12	Back	10	Top	P-Sensor Off	20525	836.5	21.96	23.00	1.271	-0.08	0.062	0.079
	LTE Band 5	10M	QPSK	1	0	Front	10	Bottom	P-Sensor Off	20525	836.5	22.90	24.00	1.288	-0.12	0.074	0.095
	LTE Band 5	10M	QPSK	25	12	Front	10	Bottom	P-Sensor Off	20525	836.5	21.96	23.00	1.271	-0.01	0.061	0.078
33	LTE Band 5	10M	QPSK	1	0	Back	10	Bottom	P-Sensor Off	20525	836.5	22.90	24.00	1.288	-0.05	0.119	0.153
	LTE Band 5	10M	QPSK	25	12	Back	10	Bottom	P-Sensor Off	20525	836.5	21.96	23.00	1.271	-0.03	0.082	0.104
	LTE Band 4	20M	QPSK	1	0	Front	10	Top	P-Sensor On	20175	1732.5	19.68	20.50	1.208	0.12	0.118	0.143
	LTE Band 4	20M	QPSK	50	0	Front	10	Top	P-Sensor On	20175	1732.5	18.73	19.50	1.194	0.13	0.095	0.113
	LTE Band 4	20M	QPSK	1	0	Back	10	Top	P-Sensor On	20175	1732.5	19.68	20.50	1.208	0.08	0.166	0.200
	LTE Band 4	20M	QPSK	50	0	Back	10	Top	P-Sensor On	20175	1732.5	18.73	19.50	1.194	-0.15	0.136	0.162
	LTE Band 4	20M	QPSK	1	0	Front	10	Bottom	P-Sensor On	20175	1732.5	19.68	20.50	1.208	-0.04	0.245	0.296
	LTE Band 4	20M	QPSK	50	0	Front	10	Bottom	P-Sensor On	20175	1732.5	18.73	19.50	1.194	-0.05	0.191	0.228
34	LTE Band 4	20M	QPSK	1	0	Back	10	Bottom	P-Sensor On	20175	1732.5	19.68	20.50	1.208	0.01	0.591	0.714
	LTE Band 4	20M	QPSK	50	0	Back	10	Bottom	P-Sensor On	20175	1732.5	18.73	19.50	1.194	-0.03	0.460	0.549
	LTE Band 7	20M	QPSK	1	99	Front	10	Top	P-Sensor On	21350	2560	19.84	20.50	1.164	-0.04	0.069	0.080
	LTE Band 7	20M	QPSK	50	50	Front	10	Top	P-Sensor On	21350	2560	18.76	19.50	1.186	-0.09	0.061	0.072
35	LTE Band 7	20M	QPSK	1	99	Back	10	Top	P-Sensor On	21350	2560	19.84	20.50	1.164	-0.01	0.166	0.193
	LTE Band 7	20M	QPSK	1	99	Back	10	Top	P-Sensor On	21350(PCC) + 21152(SCC)	2560(PCC) + 2540.2(SCC)	19.82	20.50	1.169	0.05	0.141	0.165
	LTE Band 7	20M	QPSK	50	50	Back	10	Top	P-Sensor On	21350	2560	18.76	19.50	1.186	-0.03	0.134	0.159
	LTE Band 7	20M	QPSK	1	99	Front	10	Bottom	P-Sensor On	21350	2560	19.84	20.50	1.164	-0.08	0.123	0.143
	LTE Band 7	20M	QPSK	50	50	Front	10	Bottom	P-Sensor On	21350	2560	18.76	19.50	1.186	-0.04	0.096	0.114
	LTE Band 7	20M	QPSK	1	99	Back	10	Bottom	P-Sensor On	21350	2560	19.84	20.50	1.164	-0.02	0.130	0.151
	LTE Band 7	20M	QPSK	1	99	Back	10	Bottom	P-Sensor On	21350(PCC) + 21152(SCC)	2560(PCC) + 2540.2(SCC)	19.82	20.50	1.169	-0.08	0.106	0.124
	LTE Band 7	20M	QPSK	50	50	Back	10	Bottom	P-Sensor On	21350	2560	18.76	19.50	1.186	-0.05	0.102	0.121

<TDD LTE SAR>

Plot No.	Band	BW (MHz)	Modulation	RB Size	RB Offset	Test Position	Gap (mm)	Antenna	Power Mode	Ch.	Freq. (MHz)	Average Power (dBm)	Tune-Up Limit (dBm)	Tune-up Scaling Factor	Duty Cycle %	Duty Cycle Scaling Factor	Power Drift (dB)	Measured 1g SAR (W/kg)	Reported 1g SAR (W/kg)
	LTE Band 38	20M	QPSK	1	49	Front	10	Top	P-Sensor On	38000	2595	20.48	22.00	1.419	62.9	1.006	-0.09	0.051	0.073
	LTE Band 38	20M	QPSK	50	50	Front	10	Top	P-Sensor On	38000	2595	19.56	21.00	1.393	62.9	1.006	-0.03	0.038	0.054
	LTE Band 38	20M	QPSK	1	49	Back	10	Top	P-Sensor On	38000	2595	20.48	22.00	1.419	62.9	1.006	-0.03	0.098	0.140
	LTE Band 38	20M	QPSK	1	49	Back	10	Top	P-Sensor On	37901(PCC) + 38099(SCC)	2585.1(PCC) + 2604.9(SCC)	20.66	22.00	1.361	62.9	1.006	-0.02	0.095	0.130
	LTE Band 38	20M	QPSK	50	50	Back	10	Top	P-Sensor On	38000	2595	19.56	21.00	1.393	62.9	1.006	-0.08	0.083	0.116
	LTE Band 38	20M	QPSK	1	49	Front	10	Bottom	P-Sensor On	38000	2595	20.48	22.00	1.419	62.9	1.006	-0.07	0.095	0.135
	LTE Band 38	20M	QPSK	50	50	Front	10	Bottom	P-Sensor On	38000	2595	19.56	21.00	1.393	62.9	1.006	-0.08	0.076	0.107
36	LTE Band 38	20M	QPSK	1	49	Back	10	Bottom	P-Sensor On	38000	2595	20.48	22.00	1.419	62.9	1.006	0.03	0.099	0.141
	LTE Band 38	20M	QPSK	1	49	Back	10	Bottom	P-Sensor On	37901(PCC) + 38099(SCC)	2585.1(PCC) + 2604.9(SCC)	20.66	22.00	1.361	62.9	1.006	0.05	0.085	0.116
	LTE Band 38	20M	QPSK	50	50	Back	10	Bottom	P-Sensor On	38000	2595	19.56	21.00	1.393	62.9	1.006	-0.09	0.078	0.109



<WLAN 2.4GHz SAR>

Plot No.	Band	Mode	Test Position	Gap (mm)	Ch.	Freq. (MHz)	Average Power (dBm)	Tune-Up Limit (dBm)	Tune-up Scaling Factor	Duty Cycle %	Duty Cycle Scaling Factor	Max Area Scan SAR	Power Drift (dB)	Measured 1g SAR (W/kg)	Reported 1g SAR (W/kg)
	WLAN 2.4GHz	802.11b 1Mbps	Front	10	11	2462	17.05	18.5	1.396	100	1.000	0.131			
37	WLAN 2.4GHz	802.11b 1Mbps	Back	10	11	2462	17.05	18.5	1.396	100	1.000	0.236	0.03	0.151	0.211

<WLAN 5GHz SAR>

Plot No.	Band	Mode	Test Position	Gap (mm)	Ch.	Freq. (MHz)	Average Power (dBm)	Tune-Up Limit (dBm)	Tune-up Scaling Factor	Duty Cycle %	Duty Cycle Scaling Factor	Max Area Scan SAR	Power Drift (dB)	Measured 1g SAR (W/kg)	Reported 1g SAR (W/kg)
	WLAN5.3GHz	802.11a 6Mbps	Front	10	52	5260	16.27	16.50	1.054	95	1.053	0.187			
38	WLAN5.3GHz	802.11a 6Mbps	Back	10	52	5260	16.27	16.50	1.054	95	1.053	0.510	-0.02	0.192	0.213
	WLAN5.5GHz	802.11a 6Mbps	Front	10	100	5500	15.88	16.5	1.153	95	1.053	0.185			
39	WLAN5.5GHz	802.11a 6Mbps	Back	10	100	5500	15.88	16.5	1.153	95	1.053	0.441	-0.15	0.166	0.202
	WLAN5.8GHz	802.11a 6Mbps	Front	10	161	5805	15.34	16.5	1.306	95	1.053	0.154			
40	WLAN5.8GHz	802.11a 6Mbps	Back	10	161	5805	15.34	16.5	1.306	95	1.053	0.280	-0.09	0.092	0.127

<Bluetooth SAR>

Plot No.	Band	Mode	Test Position	Gap (mm)	Ch.	Freq. (MHz)	Average Power (dBm)	Tune-Up Limit (dBm)	Tune-up Scaling Factor	Duty Cycle %	Duty Cycle Scaling Factor	Power Drift (dB)	Measured 1g SAR (W/kg)	Reported 1g SAR (W/kg)
	Bluetooth	1Mbps	Front	10	78	2480	8.87	10	1.297	76.63	1.087	0.02	0.010	0.014
41	Bluetooth	1Mbps	Back	10	78	2480	8.87	10	1.297	76.63	1.087	-0.03	0.021	0.030



15.4 Product specific 10g SAR

<WLAN 5GHz SAR>

Plot No.	Band	Mode	Test Position	Gap (mm)	Ch.	Freq. (MHz)	Average Power (dBm)	Tune-Up Limit (dBm)	Tune-up Scaling Factor	Duty Cycle %	Duty Cycle Scaling Factor	Max Area Scan SAR	Power Drift (dB)	Measured 10g SAR (W/kg)	Reported 10g SAR (W/kg)
	WLAN5.3GHz	802.11a 6Mbps	Front	0	52	5260	16.27	16.5	1.054	95	1.053	1.269			
	WLAN5.3GHz	802.11a 6Mbps	Back	0	52	5260	16.27	16.5	1.054	95	1.053	7.261			
	WLAN5.3GHz	802.11a 6Mbps	Right Side	0	52	5260	16.27	16.5	1.054	95	1.053	0.647			
42	WLAN5.3GHz	802.11a 6Mbps	Top Side	0	52	5260	16.27	16.5	1.054	95	1.053	7.834	-0.07	0.629	0.698
	WLAN5.5GHz	802.11a 6Mbps	Front	0	100	5500	15.88	16.5	1.153	95	1.053	0.965			
	WLAN5.5GHz	802.11a 6Mbps	Back	0	100	5500	15.88	16.5	1.153	95	1.053	4.510			
	WLAN5.5GHz	802.11a 6Mbps	Right Side	0	100	5500	15.88	16.5	1.153	95	1.053	0.463			
43	WLAN5.5GHz	802.11a 6Mbps	Top Side	0	100	5500	15.88	16.5	1.153	95	1.053	5.847	-0.04	0.417	0.506

15.5 Repeated SAR Measurement

<1g SAR>

No.	Band	Mode	Test Position	Gap (mm)	Antenna	Power Mode	Ch.	Freq. (MHz)	Average Power (dBm)	Tune-Up Limit (dBm)	Tune-up Scaling Factor	Power Drift (dB)	Measured 1g SAR (W/kg)	Ratio	Reported 1g SAR (W/kg)
1st	WCDMA Band IV	RMC 12.2Kbps	Bottom Side	10	Bottom	P-Sensor On	1312	1712.4	20.08	21.50	1.387	-0.14	0.820	1	1.137
2nd	WCDMA Band IV	RMC 12.2Kbps	Bottom Side	10	Bottom	P-Sensor On	1312	1712.4	20.08	21.50	1.387	0.03	0.810	1.012	1.123

General Note:

1. Per KDB 865664 D01v01r04, for each frequency band, repeated SAR measurement is required only when the measured SAR is $\geq 0.8W/kg$.
2. Per KDB 865664 D01v01r04, if the ratio among the repeated measurement is ≤ 1.2 and the measured SAR $< 1.45W/kg$, only one repeated measurement is required.
3. Per KDB 865664 D01v01r04, if the extremity repeated SAR is necessary, the same procedures should be adapted for measurements according to extremity and occupational exposure limits by applying a factor of 2.5 for extremity exposure and a factor of 5 for occupational exposure to the corresponding SAR thresholds.
4. The ratio is the difference in percentage between original and repeated *measured* SAR.
5. All measurement SAR result is scaled-up to account for tune-up tolerance and is compliant.

16. Simultaneous Transmission Analysis

No.	Simultaneous Transmission Configurations	Portable Handset			Note
		Head	Body-worn	Hotspot	
1.	GSM Voice + WLAN2.4GHz	Yes	Yes		
2.	GPRS/EDGE + WLAN2.4GHz	Yes	Yes	Yes	WLAN Hotspot
3.	WCDMA + WLAN2.4GHz	Yes	Yes	Yes	WLAN Hotspot
4.	LTE + WLAN2.4GHz	Yes	Yes	Yes	WLAN Hotspot
5.	GSM Voice + WLAN5.3/5.5GHz	Yes	Yes		
6.	GPRS/EDGE + WLAN5.3/5.5GHz	Yes	Yes		WLAN Direct (GC only)
7.	WCDMA + WLAN5.3/5.5GHz	Yes	Yes		WLAN Direct (GC only)
8.	LTE + WLAN5.3/5.5GHz	Yes	Yes		WLAN Direct (GC only)
9.	GSM Voice + WLAN5.2/5.8GHz	Yes	Yes		
10.	GPRS/EDGE + WLAN5.2/5.8GHz	Yes	Yes	Yes	WLAN Hotspot/Direct(GC/GO)
11.	WCDMA + WLAN5.2/5.8GHz	Yes	Yes	Yes	WLAN Hotspot/Direct(GC/GO)
12.	LTE + WLAN5.2/5.8GHz	Yes	Yes	Yes	WLAN Hotspot/Direct(GC/GO)
13.	GSM Voice + Bluetooth	Yes	Yes		
14.	GPRS/EDGE + Bluetooth	Yes	Yes	Yes	BT Tethering
15.	WCDMA + Bluetooth	Yes	Yes	Yes	BT Tethering
16.	LTE + Bluetooth	Yes	Yes	Yes	BT Tethering

General Note:

1. This device supports VoIP in GPRS, EGPRS, WCDMA and LTE (e.g. for 3rd-party VoIP), LTE supports VoLTE operation.
2. EUT will choose each GSM, WCDMA and LTE according to the network signal condition; therefore, they will not operate simultaneously at any moment.
3. WLAN and Bluetooth share the same antenna, so can't transmit simultaneously.
4. EUT will choose either WLAN 2.4GHz or WLAN 5GHz according to the network signal condition; therefore, 2.4GHz WLAN and 5GHz WLAN will not operate simultaneously at any moment.
5. This device supports Bluetooth tethering function.
6. This device 2.4GHz WLAN5.2GHz/WLAN5.8GHz support hotspot operation, and WLAN 5.2GHz/5.8GHz WLAN supports WiFi Direct (GC/GO), and 5.3GHz / 5.5GHz supports WiFi Direct (GC only).
7. The worst case 5 GHz WLAN SAR for each configuration was used for SAR summation.
8. Chose the worst zoom scan SAR of WLAN correspondingly for co-located with WWAN analysis.
9. The reported SAR summation is calculated based on the same configuration and test position.
10. Per KDB 447498 D01v06, simultaneous transmission SAR is compliant if,
 - i) 1g Scalar SAR summation < 1.6W/kg and 10g Scalar SAR summation < 4.0W/kg.
 - ii) $SPLSR = (SAR1 + SAR2)^{1.5} / (\text{min. separation distance, mm})$, and the peak separation distance is determined from the square root of $[(x1-x2)^2 + (y1-y2)^2 + (z1-z2)^2]$, where (x1, y1, z1) and (x2, y2, z2) are the coordinates of the extrapolated peak SAR locations in the zoom scan.
 - iii) If $SPLSR \leq 0.04$ for 1g SAR, $SPLSR \leq 0.10$ for 10g SAR simultaneously transmission SAR measurement is not necessary.
 - iv) Simultaneously transmission SAR measurement, and the reported multi-band 1g SAR < 1.6W/kg and 10g SAR < 4.0W/kg.
 - v) For WWAN product specific 10g stand-alone SAR is not required for a transmitter or antenna, due to 1g hotspot SAR is <1.2W/kg.



16.1 Head Exposure Conditions

Top Antenna

WWAN Band		Exposure Position	1	2	3	4	1+2 Summed 1g SAR (W/kg)	1+3 Summed 1g SAR (W/kg)	1+4 Summed 1g SAR (W/kg)
			WWAN	2.4GHz WLAN	5GHz WLAN	Bluetooth			
			1g SAR (W/kg)	1g SAR (W/kg)	1g SAR (W/kg)	1g SAR (W/kg)			
GSM	GSM850	Right Cheek	0.402	0.647	0.723	0.084	1.05	1.13	0.49
		Right Tilted	0.370	0.647	0.723	0.084	1.02	1.09	0.45
		Left Cheek	0.314	0.647	0.723	0.084	0.96	1.04	0.40
		Left Tilted	0.321	0.647	0.723	0.084	0.97	1.04	0.41
	GSM1900	Right Cheek	0.534	0.647	0.723	0.084	1.18	1.26	0.62
		Right Tilted	0.644	0.647	0.723	0.084	1.29	1.37	0.73
		Left Cheek	0.319	0.647	0.723	0.084	0.97	1.04	0.40
		Left Tilted	0.403	0.647	0.723	0.084	1.05	1.13	0.49
WCDMA	Band V	Right Cheek	0.273	0.647	0.723	0.084	0.92	1.00	0.36
		Right Tilted	0.254	0.647	0.723	0.084	0.90	0.98	0.34
		Left Cheek	0.203	0.647	0.723	0.084	0.85	0.93	0.29
		Left Tilted	0.206	0.647	0.723	0.084	0.85	0.93	0.29
	Band IV	Right Cheek	0.624	0.647	0.723	0.084	1.27	1.35	0.71
		Right Tilted	0.628	0.647	0.723	0.084	1.28	1.35	0.71
		Left Cheek	0.388	0.647	0.723	0.084	1.04	1.11	0.47
		Left Tilted	0.442	0.647	0.723	0.084	1.09	1.17	0.53
	Band II	Right Cheek	0.702	0.647	0.723	0.084	1.35	1.43	0.79
		Right Tilted	0.721	0.647	0.723	0.084	1.37	1.44	0.81
		Left Cheek	0.430	0.647	0.723	0.084	1.08	1.15	0.51
		Left Tilted	0.453	0.647	0.723	0.084	1.10	1.18	0.54
LTE	Band 5	Right Cheek	0.272	0.647	0.723	0.084	0.92	1.00	0.36
		Right Tilted	0.265	0.647	0.723	0.084	0.91	0.99	0.35
		Left Cheek	0.216	0.647	0.723	0.084	0.86	0.94	0.30
		Left Tilted	0.216	0.647	0.723	0.084	0.86	0.94	0.30
	Band 4	Right Cheek	0.470	0.647	0.723	0.084	1.12	1.19	0.55
		Right Tilted	0.530	0.647	0.723	0.084	1.18	1.25	0.61
		Left Cheek	0.331	0.647	0.723	0.084	0.98	1.05	0.42
		Left Tilted	0.380	0.647	0.723	0.084	1.03	1.10	0.46
	Band 7	Right Cheek	0.682	0.647	0.723	0.084	1.33	1.41	0.77
		Right Tilted	0.751	0.647	0.723	0.084	1.40	1.47	0.84
		Left Cheek	0.390	0.647	0.723	0.084	1.04	1.11	0.47
		Left Tilted	0.399	0.647	0.723	0.084	1.05	1.12	0.48
	Band 38	Right Cheek	0.567	0.647	0.723	0.084	1.21	1.29	0.65
		Right Tilted	0.615	0.647	0.723	0.084	1.26	1.34	0.70
		Left Cheek	0.300	0.647	0.723	0.084	0.95	1.02	0.38
		Left Tilted	0.331	0.647	0.723	0.084	0.98	1.05	0.42



Bottom Antenna

WWAN Band		Exposure Position	1	2	3	4	1+2 Summed 1g SAR (W/kg)	1+3 Summed 1g SAR (W/kg)	1+4 Summed 1g SAR (W/kg)
			WWAN	2.4GHz WLAN	5GHz WLAN	Bluetooth			
			1g SAR (W/kg)	1g SAR (W/kg)	1g SAR (W/kg)	1g SAR (W/kg)			
GSM	GSM850	Right Cheek	0.133	0.647	0.723	0.084	0.78	0.86	0.22
		Right Tilted	0.067	0.647	0.723	0.084	0.71	0.79	0.15
		Left Cheek	0.140	0.647	0.723	0.084	0.79	0.86	0.22
		Left Tilted	0.066	0.647	0.723	0.084	0.71	0.79	0.15
	GSM1900	Right Cheek	0.034	0.647	0.723	0.084	0.68	0.76	0.12
		Right Tilted	0.020	0.647	0.723	0.084	0.67	0.74	0.10
		Left Cheek	0.023	0.647	0.723	0.084	0.67	0.75	0.11
		Left Tilted	0.018	0.647	0.723	0.084	0.67	0.74	0.10
WCDMA	Band V	Right Cheek	0.079	0.647	0.723	0.084	0.73	0.80	0.16
		Right Tilted	0.046	0.647	0.723	0.084	0.69	0.77	0.13
		Left Cheek	0.088	0.647	0.723	0.084	0.74	0.81	0.17
		Left Tilted	0.044	0.647	0.723	0.084	0.69	0.77	0.13
	Band IV	Right Cheek	0.105	0.647	0.723	0.084	0.75	0.83	0.19
		Right Tilted	0.050	0.647	0.723	0.084	0.70	0.77	0.13
		Left Cheek	0.061	0.647	0.723	0.084	0.71	0.78	0.15
		Left Tilted	0.060	0.647	0.723	0.084	0.71	0.78	0.14
	Band II	Right Cheek	0.047	0.647	0.723	0.084	0.69	0.77	0.13
		Right Tilted	0.016	0.647	0.723	0.084	0.66	0.74	0.10
		Left Cheek	0.038	0.647	0.723	0.084	0.69	0.76	0.12
		Left Tilted	0.041	0.647	0.723	0.084	0.69	0.76	0.13
LTE	Band 5	Right Cheek	0.079	0.647	0.723	0.084	0.73	0.80	0.16
		Right Tilted	0.044	0.647	0.723	0.084	0.69	0.77	0.13
		Left Cheek	0.082	0.647	0.723	0.084	0.73	0.81	0.17
		Left Tilted	0.041	0.647	0.723	0.084	0.69	0.76	0.13
	Band 4	Right Cheek	0.097	0.647	0.723	0.084	0.74	0.82	0.18
		Right Tilted	0.047	0.647	0.723	0.084	0.69	0.77	0.13
		Left Cheek	0.050	0.647	0.723	0.084	0.70	0.77	0.13
		Left Tilted	0.051	0.647	0.723	0.084	0.70	0.77	0.14
	Band 7	Right Cheek	0.055	0.647	0.723	0.084	0.70	0.78	0.14
		Right Tilted	0.068	0.647	0.723	0.084	0.72	0.79	0.15
		Left Cheek	0.104	0.647	0.723	0.084	0.75	0.83	0.19
		Left Tilted	0.059	0.647	0.723	0.084	0.71	0.78	0.14
	Band 38	Right Cheek	0.051	0.647	0.723	0.084	0.70	0.77	0.14
		Right Tilted	0.041	0.647	0.723	0.084	0.69	0.76	0.13
		Left Cheek	0.080	0.647	0.723	0.084	0.73	0.80	0.16
		Left Tilted	0.050	0.647	0.723	0.084	0.70	0.77	0.13



16.2 Hotspot Exposure Conditions

Top Antenna

WWAN Band		Exposure Position	1	2	3	4	1+2 Summed 1g SAR (W/kg)	1+3 Summed 1g SAR (W/kg)	1+4 Summed 1g SAR (W/kg)
			WWAN	2.4GHz WLAN	5GHz WLAN	Bluetooth			
			1g SAR (W/kg)	1g SAR (W/kg)	1g SAR (W/kg)	1g SAR (W/kg)			
GSM	GSM850	Front	0.094	0.211	0.291	0.014	0.31	0.39	0.11
		Back	0.161	0.211	0.291	0.030	0.37	0.45	0.19
		Left Side	0.079				0.08	0.08	0.08
		Right Side		0.211	0.291	0.012	0.21	0.29	0.01
		Top Side	0.123	0.211	0.291	0.004	0.33	0.41	0.13
	GSM1900	Front	0.089	0.211	0.291	0.014	0.30	0.38	0.10
		Back	0.137	0.211	0.291	0.030	0.35	0.43	0.17
		Left Side	0.056				0.06	0.06	0.06
		Right Side		0.211	0.291	0.012	0.21	0.29	0.01
		Top Side	0.156	0.211	0.291	0.004	0.37	0.45	0.16
WCDMA	Band V	Front	0.053	0.211	0.291	0.014	0.26	0.34	0.07
		Back	0.112	0.211	0.291	0.030	0.32	0.40	0.14
		Left Side	0.040				0.04	0.04	0.04
		Right Side		0.211	0.291	0.012	0.21	0.29	0.01
		Top Side	0.077	0.211	0.291	0.004	0.29	0.37	0.08
	Band IV	Front	0.171	0.211	0.291	0.014	0.38	0.46	0.19
		Back	0.233	0.211	0.291	0.030	0.44	0.52	0.26
		Left Side	0.055				0.06	0.06	0.06
		Right Side		0.211	0.291	0.012	0.21	0.29	0.01
		Top Side	0.265	0.211	0.291	0.004	0.48	0.56	0.27
	Band II	Front	0.172	0.211	0.291	0.014	0.38	0.46	0.19
		Back	0.248	0.211	0.291	0.030	0.46	0.54	0.28
		Left Side	0.096				0.10	0.10	0.10
		Right Side		0.211	0.291	0.012	0.21	0.29	0.01
		Top Side	0.276	0.211	0.291	0.004	0.49	0.57	0.28
LTE	Band 5	Front	0.064	0.211	0.291	0.014	0.28	0.36	0.08
		Back	0.108	0.211	0.291	0.030	0.32	0.40	0.14
		Left Side	0.048				0.05	0.05	0.05
		Right Side		0.211	0.291	0.012	0.21	0.29	0.01
		Top Side	0.077	0.211	0.291	0.004	0.29	0.37	0.08
	Band 4	Front	0.143	0.211	0.291	0.014	0.35	0.43	0.16
		Back	0.200	0.211	0.291	0.030	0.41	0.49	0.23
		Left Side	0.056				0.06	0.06	0.06
		Right Side		0.211	0.291	0.012	0.21	0.29	0.01
		Top Side	0.227	0.211	0.291	0.004	0.44	0.52	0.23
	Band 7	Front	0.080	0.211	0.291	0.014	0.29	0.37	0.09
		Back	0.193	0.211	0.291	0.030	0.40	0.48	0.22
		Left Side	0.019				0.02	0.02	0.02
		Right Side		0.211	0.291	0.012	0.21	0.29	0.01
		Top Side	0.187	0.211	0.291	0.004	0.40	0.48	0.19
	Band 38	Front	0.073	0.211	0.291	0.014	0.28	0.36	0.09
		Back	0.140	0.211	0.291	0.030	0.35	0.43	0.17
		Left Side	0.012				0.01	0.01	0.01
Right Side			0.211	0.291	0.012	0.21	0.29	0.01	
Top Side		0.147	0.211	0.291	0.004	0.36	0.44	0.15	



Bottom Antenna

WWAN Band		Exposure Position	1	2	3	4	1+2 Summed 1g SAR (W/kg)	1+3 Summed 1g SAR (W/kg)	1+4 Summed 1g SAR (W/kg)
			WWAN 1g SAR (W/kg)	2.4GHz WLAN 1g SAR (W/kg)	5GHz WLAN 1g SAR (W/kg)	Bluetooth 1g SAR (W/kg)			
GSM	GSM850	Front	0.135	0.211	0.291	0.014	0.35	0.43	0.15
		Back	0.227	0.211	0.291	0.030	0.44	0.52	0.26
		Left Side	0.126				0.13	0.13	0.13
		Right Side	0.127	0.211	0.291	0.012	0.34	0.42	0.14
		Top Side		0.211	0.291	0.004	0.21	0.29	0.00
	Bottom Side	0.066				0.07	0.07	0.07	
	GSM1900	Front	0.194	0.211	0.291	0.014	0.41	0.49	0.21
		Back	0.466	0.211	0.291	0.030	0.68	0.76	0.50
		Left Side	0.011				0.01	0.01	0.01
		Right Side	0.037	0.211	0.291	0.012	0.25	0.33	0.05
Top Side			0.211	0.291	0.004	0.21	0.29	0.00	
Bottom Side	0.564				0.56	0.56	0.56		
WCDMA	Band V	Front	0.090	0.211	0.291	0.014	0.30	0.38	0.10
		Back	0.130	0.211	0.291	0.030	0.34	0.42	0.16
		Left Side	0.076				0.08	0.08	0.08
		Right Side	0.085	0.211	0.291	0.012	0.30	0.38	0.10
		Top Side		0.211	0.291	0.004	0.21	0.29	0.00
	Bottom Side	0.033				0.03	0.03	0.03	
	Band IV	Front	0.336	0.211	0.291	0.014	0.55	0.63	0.35
		Back	0.775	0.211	0.291	0.030	0.99	1.07	0.81
		Left Side	0.012				0.01	0.01	0.01
		Right Side	0.097	0.211	0.291	0.012	0.31	0.39	0.11
		Top Side		0.211	0.291	0.004	0.21	0.29	0.00
	Bottom Side	1.137				1.14	1.14	1.14	
	Band II	Front	0.196	0.211	0.291	0.014	0.41	0.49	0.21
		Back	0.471	0.211	0.291	0.030	0.68	0.76	0.50
		Left Side	0.010				0.01	0.01	0.01
		Right Side	0.032	0.211	0.291	0.012	0.24	0.32	0.04
		Top Side		0.211	0.291	0.004	0.21	0.29	0.00
	Bottom Side	0.564				0.56	0.56	0.56	
LTE	Band 5	Front	0.095	0.211	0.291	0.014	0.31	0.39	0.11
		Back	0.153	0.211	0.291	0.030	0.36	0.44	0.18
		Left Side	0.082				0.08	0.08	0.08
		Right Side	0.086	0.211	0.291	0.012	0.30	0.38	0.10
		Top Side		0.211	0.291	0.004	0.21	0.29	0.00
	Bottom Side	0.030				0.03	0.03	0.03	
	Band 4	Front	0.296	0.211	0.291	0.014	0.51	0.59	0.31
		Back	0.714	0.211	0.291	0.030	0.93	1.01	0.74
		Left Side	0.012				0.01	0.01	0.01
		Right Side	0.109	0.211	0.291	0.012	0.32	0.40	0.12
		Top Side		0.211	0.291	0.004	0.21	0.29	0.00
	Bottom Side	0.889				0.89	0.89	0.89	
	Band 7	Front	0.143	0.211	0.291	0.014	0.35	0.43	0.16
		Back	0.151	0.211	0.291	0.030	0.36	0.44	0.18
		Left Side	0.089				0.09	0.09	0.09
		Right Side	0.100	0.211	0.291	0.012	0.31	0.39	0.11
		Top Side		0.211	0.291	0.004	0.21	0.29	0.00
	Bottom Side	0.236				0.24	0.24	0.24	
	Band 38	Front	0.135	0.211	0.291	0.014	0.35	0.43	0.15
		Back	0.141	0.211	0.291	0.030	0.35	0.43	0.17
		Left Side	0.100				0.10	0.10	0.10
Right Side		0.073	0.211	0.291	0.012	0.28	0.36	0.09	
Top Side			0.211	0.291	0.004	0.21	0.29	0.00	
Bottom Side	0.224				0.22	0.22	0.22		



16.3 Body-Worn Accessory Exposure Conditions

Top Antenna

WWAN Band		Exposure Position	1	2	3	4	1+2 Summed 1g SAR (W/kg)	1+3 Summed 1g SAR (W/kg)	1+4 Summed 1g SAR (W/kg)
			WWAN	2.4GHz WLAN	5GHz WLAN	Bluetooth			
			1g SAR (W/kg)	1g SAR (W/kg)	1g SAR (W/kg)	1g SAR (W/kg)			
GSM	GSM850	Front	0.094	0.211	0.213	0.014	0.31	0.31	0.11
		Back	0.161	0.211	0.213	0.030	0.37	0.37	0.19
	GSM1900	Front	0.089	0.211	0.213	0.014	0.30	0.30	0.10
		Back	0.137	0.211	0.213	0.030	0.35	0.35	0.17
WCDMA	Band V	Front	0.053	0.211	0.213	0.014	0.26	0.27	0.07
		Back	0.112	0.211	0.213	0.030	0.32	0.33	0.14
	Band IV	Front	0.171	0.211	0.213	0.014	0.38	0.38	0.19
		Back	0.233	0.211	0.213	0.030	0.44	0.45	0.26
	Band II	Front	0.172	0.211	0.213	0.014	0.38	0.39	0.19
		Back	0.248	0.211	0.213	0.030	0.46	0.46	0.28
LTE	Band 5	Front	0.064	0.211	0.213	0.014	0.28	0.28	0.08
		Back	0.108	0.211	0.213	0.030	0.32	0.32	0.14
	Band 4	Front	0.143	0.211	0.213	0.014	0.35	0.36	0.16
		Back	0.200	0.211	0.213	0.030	0.41	0.41	0.23
	Band 7	Front	0.080	0.211	0.213	0.014	0.29	0.29	0.09
		Back	0.193	0.211	0.213	0.030	0.40	0.41	0.22
	Band 38	Front	0.073	0.211	0.213	0.014	0.28	0.29	0.09
		Back	0.140	0.211	0.213	0.030	0.35	0.35	0.17

Bottom Antenna

WWAN Band		Exposure Position	1	2	3	4	1+2 Summed 1g SAR (W/kg)	1+3 Summed 1g SAR (W/kg)	1+4 Summed 1g SAR (W/kg)
			WWAN	2.4GHz WLAN	5GHz WLAN	Bluetooth			
			1g SAR (W/kg)	1g SAR (W/kg)	1g SAR (W/kg)	1g SAR (W/kg)			
GSM	GSM850	Front	0.135	0.211	0.213	0.014	0.35	0.35	0.15
		Back	0.227	0.211	0.213	0.030	0.44	0.44	0.26
	GSM1900	Front	0.194	0.211	0.213	0.014	0.41	0.41	0.21
		Back	0.466	0.211	0.213	0.030	0.68	0.68	0.50
WCDMA	Band V	Front	0.090	0.211	0.213	0.014	0.30	0.30	0.10
		Back	0.130	0.211	0.213	0.030	0.34	0.34	0.16
	Band IV	Front	0.336	0.211	0.213	0.014	0.55	0.55	0.35
		Back	0.775	0.211	0.213	0.030	0.99	0.99	0.81
	Band II	Front	0.196	0.211	0.213	0.014	0.41	0.41	0.21
		Back	0.471	0.211	0.213	0.030	0.68	0.68	0.50
LTE	Band 5	Front	0.095	0.211	0.213	0.014	0.31	0.31	0.11
		Back	0.153	0.211	0.213	0.030	0.36	0.37	0.18
	Band 4	Front	0.296	0.211	0.213	0.014	0.51	0.51	0.31
		Back	0.714	0.211	0.213	0.030	0.93	0.93	0.74
	Band 7	Front	0.143	0.211	0.213	0.014	0.35	0.36	0.16
		Back	0.151	0.211	0.213	0.030	0.36	0.36	0.18
	Band 38	Front	0.135	0.211	0.213	0.014	0.35	0.35	0.15
		Back	0.141	0.211	0.213	0.030	0.35	0.35	0.17

Test Engineer : Nick Hu



17. Uncertainty Assessment

Per KDB 865664 D01 SAR measurement 100MHz to 6GHz, when the highest measured 1-g SAR within a frequency band is < 1.5 W/kg and the measured 10-g SAR within a frequency band is < 3.75 W/kg. The expanded SAR measurement uncertainty must be $\leq 30\%$, for a confidence interval of $k = 2$. If these conditions are met, extensive SAR measurement uncertainty analysis described in IEEE Std 1528-2013 is not required in SAR reports submitted for equipment approval. For this device, the highest measured 1-g SAR is less 1.5W/kg and highest measured 10-g SAR is less 3.75W/kg. Therefore, the measurement uncertainty table is not required in this report.



18. References

- [1] FCC 47 CFR Part 2 "Frequency Allocations and Radio Treaty Matters; General Rules and Regulations"
- [2] ANSI/IEEE Std. C95.1-1992, "IEEE Standard for Safety Levels with Respect to Human Exposure to Radio Frequency Electromagnetic Fields, 3 kHz to 300 GHz", September 1992
- [3] IEEE Std. 1528-2013, "IEEE Recommended Practice for Determining the Peak Spatial-Average Specific Absorption Rate (SAR) in the Human Head from Wireless Communications Devices: Measurement Techniques", Sep 2013
- [4] SPEAG DASY System Handbook
- [5] FCC KDB 865664 D01 v01r04, "SAR Measurement Requirements for 100 MHz to 6 GHz", Aug 2015.
- [6] FCC KDB 865664 D02 v01r02, "RF Exposure Compliance Reporting and Documentation Considerations" Oct 2015.
- [7] FCC KDB 447498 D01 v06, "Mobile and Portable Device RF Exposure Procedures and Equipment Authorization Policies", Oct 2015
- [8] FCC KDB 648474 D04 v01r03, "SAR Evaluation Considerations for Wireless Handsets", Oct 2015.
- [9] FCC KDB 248227 D01 v02r02, "SAR Guidance for IEEE 802.11 (WiFi) Transmitters", Oct 2015.
- [10] FCC KDB 941225 D01 v03r01, "3G SAR MEAUREMENT PROCEDURES", Oct 2015
- [11] FCC KDB 941225 D05 v02r05, "SAR Evaluation Considerations for LTE Devices", Dec 2015
- [12] FCC KDB 941225 D05A v01r02, "Rel. 10 LTE SAR Test Guidance and KDB Inquiries", Oct 2015
- [13] FCC KDB 941225 D06 v02r01, "SAR Evaluation Procedures for Portable Devices with Wireless Router Capabilities", Oct 2015.
- [14] FCC KDB 616217 D04 v01r02, "SAR Evaluation Considerations for Laptop, Notebook, Netbook and Tablet Computers", Oct 2015



Appendix A. Plots of System Performance Check

The plots are shown as follows.

System Check_Head_835MHz

DUT: D835V2 - SN:4d091

Communication System: UID 0, CW (0); Frequency: 835 MHz; Duty Cycle: 1:1

Medium: HSL_835 Medium parameters used: $f = 835$ MHz; $\sigma = 0.914$ S/m; $\epsilon_r = 42.773$; $\rho = 1000$ kg/m³

Ambient Temperature : 23.2 °C ; Liquid Temperature : 22.6 °C

DASY5 Configuration:

- Probe: EX3DV4 - SN3857; ConvF(9.51, 9.51, 9.51); Calibrated: 2018.5.31;
- Sensor-Surface: 1.4mm (Mechanical Surface Detection)
- Electronics: DAE4 Sn1210; Calibrated: 2018.5.28
- Phantom: SAM3; Type: SAM; Serial: TP-1542
- Measurement SW: DASY52, Version 52.8 (8); SEMCAD X Version 14.6.10 (7331)

Pin=250mW/Area Scan (61x61x1): Interpolated grid: dx=1.500 mm, dy=1.500 mm

Maximum value of SAR (interpolated) = 3.07 W/kg

Pin=250mW/Zoom Scan (5x5x7)/Cube 0: Measurement grid: dx=8mm, dy=8mm, dz=5mm

Reference Value = 53.41 V/m; Power Drift = 0.14 dB

Peak SAR (extrapolated) = 3.61 W/kg

SAR(1 g) = 2.46 W/kg; SAR(10 g) = 1.62 W/kg

Maximum value of SAR (measured) = 3.11 W/kg

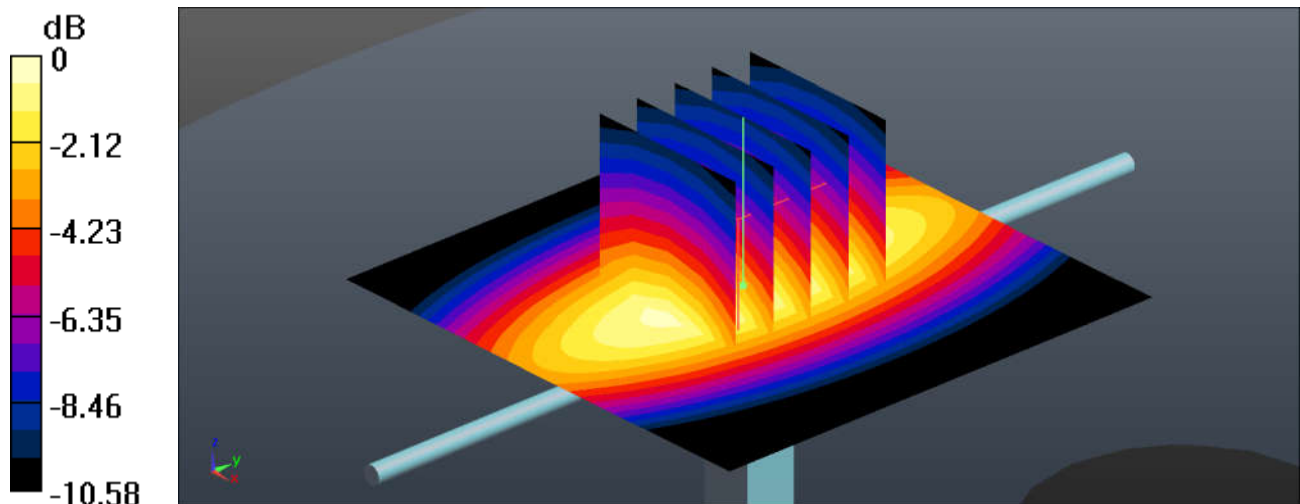

0 dB = 3.11 W/kg = 4.93 dBW/kg

System Check_Head_1750MHz

DUT: D1750V2 - SN:1069

Communication System: UID 0, CW; Frequency: 1750 MHz; Duty Cycle: 1:1

Medium: HSL_1750 Medium parameters used: $f = 1750$ MHz; $\sigma = 1.353$ S/m; $\epsilon_r = 40.644$; $\rho = 1000$ kg/m³

Ambient Temperature : 23.2 °C ; Liquid Temperature : 22.7 °C

DASY5 Configuration:

- Probe: EX3DV4 - SN3857; ConvF(8.29, 8.29, 8.29); Calibrated: 2018.5.31;
- Sensor-Surface: 1.4mm (Mechanical Surface Detection)
- Electronics: DAE4 Sn1210; Calibrated: 2018.5.28
- Phantom: SAM2; Type: SAM; Serial: TP-1644
- Measurement SW: DASY52, Version 52.8 (8); SEMCAD X Version 14.6.10 (7331)

Pin=250mW/Area Scan (61x61x1): Interpolated grid: dx=1.500 mm, dy=1.500 mm

Maximum value of SAR (interpolated) = 13.0 W/kg

Pin=250mW/Zoom Scan (5x5x7)/Cube 0: Measurement grid: dx=8mm, dy=8mm, dz=5mm

Reference Value = 86.45 V/m; Power Drift = -0.01 dB

Peak SAR (extrapolated) = 16.5 W/kg

SAR(1 g) = 9.08 W/kg; SAR(10 g) = 4.8 W/kg

Maximum value of SAR (measured) = 13.0 W/kg

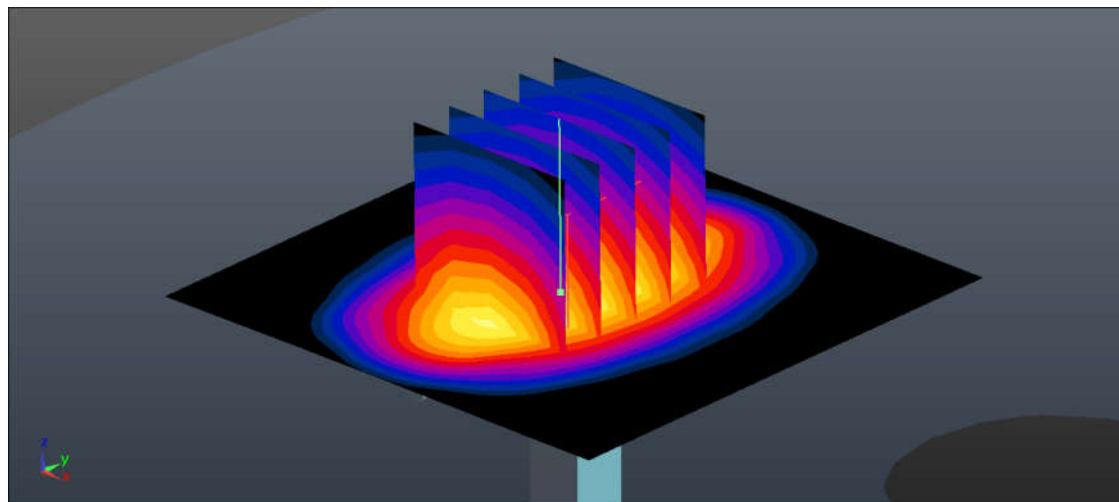
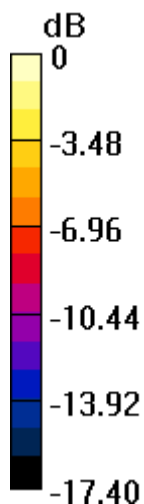

0 dB = 13.0 W/kg = 11.14 dBW/kg

System Check_Head_1900MHz

DUT: D1900V2 - SN:5d118

Communication System: UID 0, CW (0); Frequency: 1900 MHz; Duty Cycle: 1:1
Medium: HSL_1900 Medium parameters used: $f = 1900$ MHz; $\sigma = 1.428$ S/m; $\epsilon_r = 41.108$; $\rho = 1000$ kg/m³
Ambient Temperature : 23.2 °C ; Liquid Temperature : 22.8 °C

DASY5 Configuration:

- Probe: EX3DV4 - SN3857; ConvF(8.04, 8.04, 8.04); Calibrated: 2018.5.31;
- Sensor-Surface: 1.4mm (Mechanical Surface Detection)
- Electronics: DAE4 Sn1210; Calibrated: 2018.5.28
- Phantom: SAM2; Type: SAM; Serial: TP-1644
- Measurement SW: DASY52, Version 52.8 (8); SEMCAD X Version 14.6.10 (7331)

Pin=250mW/Area Scan (61x61x1): Interpolated grid: dx=1.500 mm, dy=1.500 mm
Maximum value of SAR (interpolated) = 14.5 W/kg

Pin=250mW/Zoom Scan (5x5x7)/Cube 0: Measurement grid: dx=8mm, dy=8mm, dz=5mm
Reference Value = 88.65 V/m; Power Drift = -0.08 dB
Peak SAR (extrapolated) = 18.6 W/kg
SAR(1 g) = 9.89 W/kg; SAR(10 g) = 5.06 W/kg
Maximum value of SAR (measured) = 14.4 W/kg

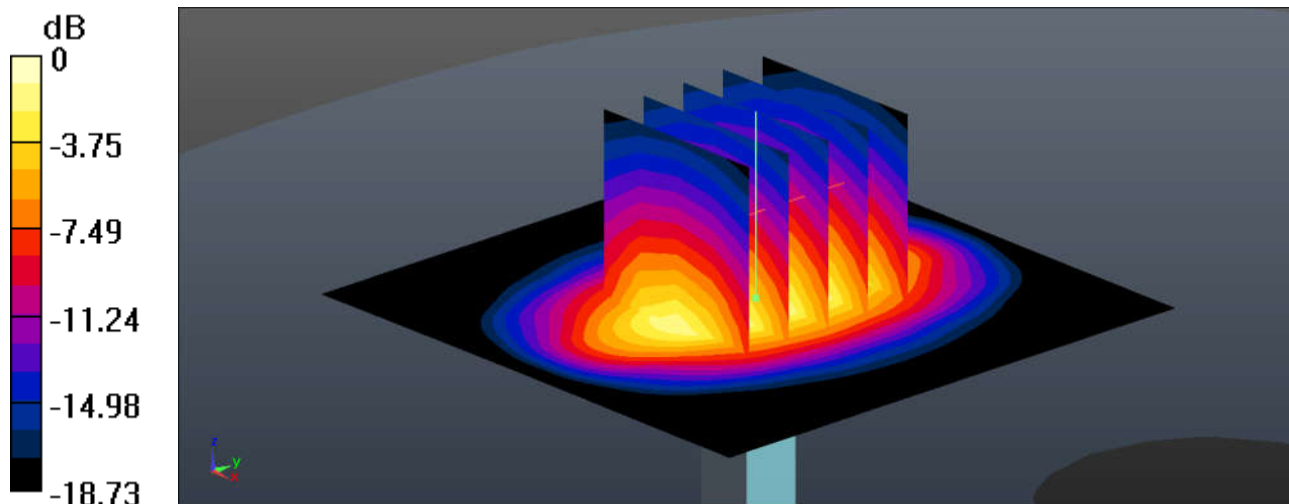

0 dB = 14.4 W/kg = 11.58 dBW/kg

System Check_Head_2450MHz

DUT: D2450V2 - SN:840

Communication System: UID 0, CW (0); Frequency: 2450 MHz;Duty Cycle: 1:1

Medium: HSL_2450 Medium parameters used: $f = 2450$ MHz; $\sigma = 1.848$ S/m; $\epsilon_r = 39.012$; $\rho = 1000$ kg/m³

Ambient Temperature : 23.2 °C ; Liquid Temperature : 22.9 °C

DASY5 Configuration:

- Probe: EX3DV4 - SN3857; ConvF(7.56, 7.56, 7.56); Calibrated: 2018.5.31;
- Sensor-Surface: 1.4mm (Mechanical Surface Detection)
- Electronics: DAE4 Sn1210; Calibrated: 2018.5.28
- Phantom: SAM3; Type: SAM; Serial: TP-1542
- Measurement SW: DASY52, Version 52.8 (8); SEMCAD X Version 14.6.10 (7331)

Pin=250mW/Area Scan (71x71x1): Interpolated grid: dx=1.200 mm, dy=1.200 mm

Maximum value of SAR (interpolated) = 20.8 W/kg

Pin=250mW/Zoom Scan (7x7x7)/Cube 0: Measurement grid: dx=5mm, dy=5mm, dz=5mm

Reference Value = 89.01 V/m; Power Drift = 0.03 dB

Peak SAR (extrapolated) = 28.0 W/kg

SAR(1 g) = 12.8 W/kg; SAR(10 g) = 5.77 W/kg

Maximum value of SAR (measured) = 20.1 W/kg

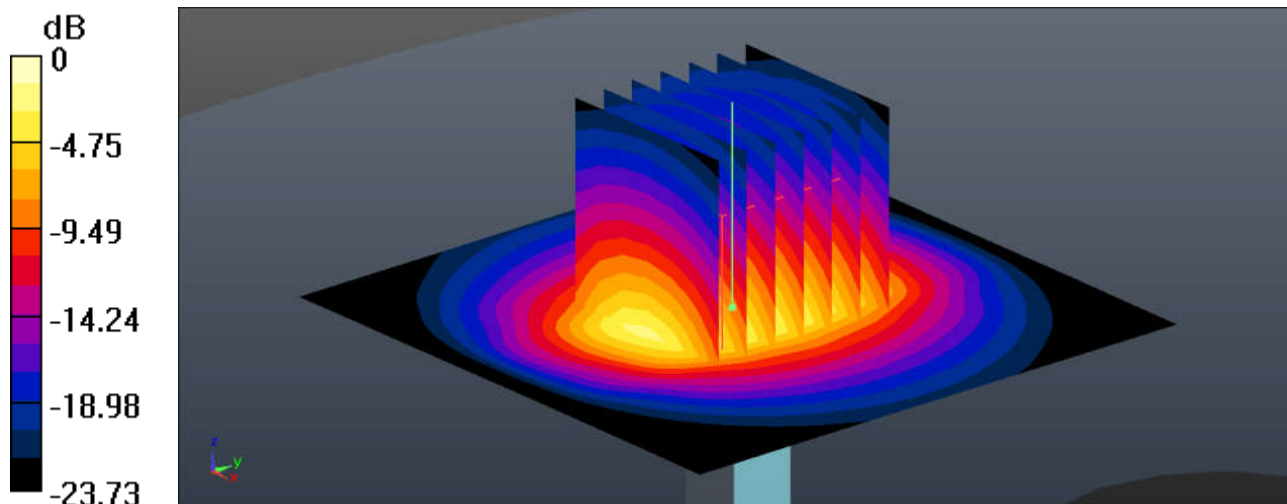

0 dB = 20.1 W/kg = 13.03 dBW/kg

System Check_Head_2600MHz

DUT: D2600V2 - SN:1061

Communication System: UID 0, CW; Frequency: 2600 MHz; Duty Cycle: 1:1

Medium: HSL_2600 Medium parameters used: $f = 2600$ MHz; $\sigma = 2.021$ S/m; $\epsilon_r = 38.375$; $\rho = 1000$ kg/m³

Ambient Temperature : 23.3 °C ; Liquid Temperature : 22.6 °C

DASY5 Configuration:

- Probe: EX3DV4 - SN3857; ConvF(7.44, 7.44, 7.44); Calibrated: 2018.5.31;
- Sensor-Surface: 1.4mm (Mechanical Surface Detection)
- Electronics: DAE4 Sn1210; Calibrated: 2018.5.28
- Phantom: SAM3; Type: SAM; Serial: TP-1542
- Measurement SW: DASY52, Version 52.8 (8); SEMCAD X Version 14.6.10 (7331)

Pin=250mW/Area Scan (71x71x1): Interpolated grid: dx=1.200 mm, dy=1.200 mm

Maximum value of SAR (interpolated) = 23.2 W/kg

Pin=250mW/Zoom Scan (7x7x7)/Cube 0: Measurement grid: dx=5mm, dy=5mm, dz=5mm

Reference Value = 87.71 V/m; Power Drift = 0.14 dB

Peak SAR (extrapolated) = 31.6 W/kg

SAR(1 g) = 14.2 W/kg; SAR(10 g) = 6.24 W/kg

Maximum value of SAR (measured) = 22.5 W/kg

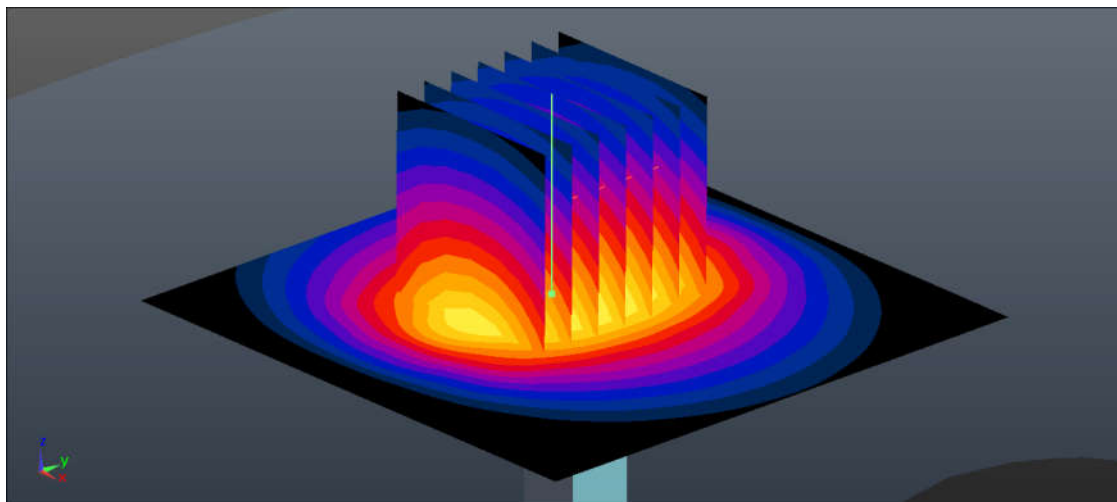
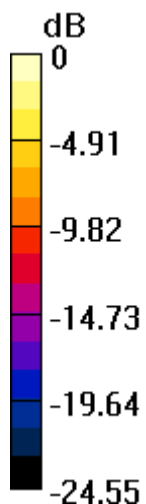

0 dB = 22.5 W/kg = 13.52 dBW/kg

System Check_Head_5250MHz

DUT: D5GHzV2-SN:1006

Communication System: UID 0, CW (0); Frequency: 5250 MHz; Duty Cycle: 1:1
Medium: HSL_5000 Medium parameters used: $f = 5250$ MHz; $\sigma = 4.865$ S/m; $\epsilon_r = 37.109$; $\rho = 1000$ kg/m³
Ambient Temperature : 23.3 °C ; Liquid Temperature : 22.7 °C

DASY5 Configuration:

- Probe: EX3DV4 - SN3857; ConvF(5.2, 5.2, 5.2); Calibrated: 2018.5.31;
- Sensor-Surface: 1.4mm (Mechanical Surface Detection)
- Electronics: DAE4 Sn1210; Calibrated: 2018.5.28
- Phantom: SAM2; Type: SAM; Serial: TP-1644
- Measurement SW: DASY52, Version 52.8 (8); SEMCAD X Version 14.6.10 (7331)

Pin=100mW/Area Scan (71x71x1): Interpolated grid: dx=1.000 mm, dy=1.000 mm
Maximum value of SAR (interpolated) = 18.6 W/kg

Pin=100mW/Zoom Scan (8x8x7)/Cube 0: Measurement grid: dx=4mm, dy=4mm, dz=1.4mm
Reference Value = 43.51 V/m; Power Drift = -0.06 dB
Peak SAR (extrapolated) = 31.8 W/kg
SAR(1 g) = 7.75 W/kg; SAR(10 g) = 2.19 W/kg
Maximum value of SAR (measured) = 18.7 W/kg

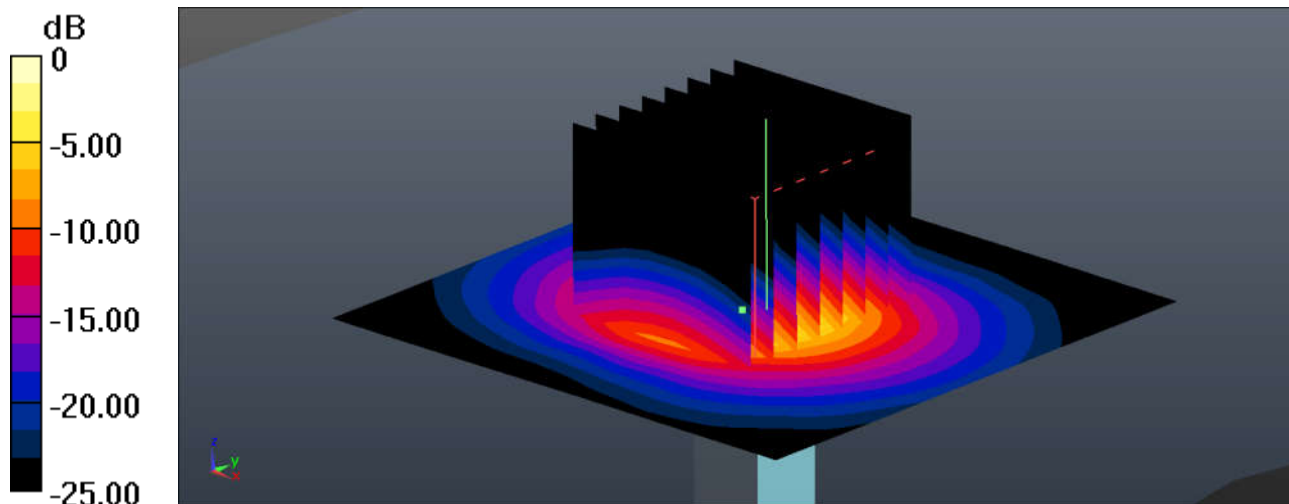

0 dB = 18.7 W/kg = 12.72 dBW/kg

System Check_Head_5600MHz

DUT: D5GHzV2-SN:1006

Communication System: UID 0, CW (0); Frequency: 5600 MHz; Duty Cycle: 1:1

Medium: HSL_5000 Medium parameters used: $f = 5600$ MHz; $\sigma = 5.207$ S/m; $\epsilon_r = 36.587$; $\rho = 1000$ kg/m³

Ambient Temperature : 23.3 °C ; Liquid Temperature : 22.8 °C

DASY5 Configuration:

- Probe: EX3DV4 - SN3857; ConvF(4.94, 4.94, 4.94); Calibrated: 2018.5.31;
- Sensor-Surface: 1.4mm (Mechanical Surface Detection)
- Electronics: DAE4 Sn1210; Calibrated: 2018.5.28
- Phantom: SAM2; Type: SAM; Serial: TP-1644
- Measurement SW: DASY52, Version 52.8 (8); SEMCAD X Version 14.6.10 (7331)

Pin=100mW/Area Scan (71x71x1): Interpolated grid: dx=1.000 mm, dy=1.000 mm

Maximum value of SAR (interpolated) = 18.6 W/kg

Pin=100mW/Zoom Scan (8x8x7)/Cube 0: Measurement grid: dx=4mm, dy=4mm, dz=1.4mm

Reference Value = 39.38 V/m; Power Drift = -0.06 dB

Peak SAR (extrapolated) = 29.5 W/kg

SAR(1 g) = 8.02 W/kg; SAR(10 g) = 2.5 W/kg

Maximum value of SAR (measured) = 18.3 W/kg

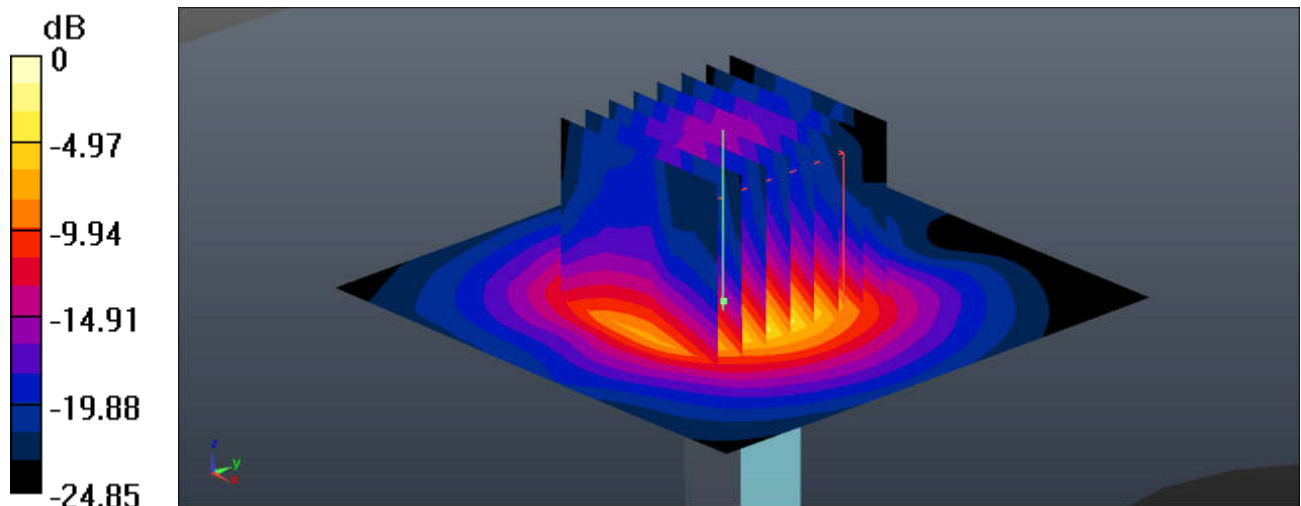

0 dB = 18.3 W/kg = 12.62 dBW/kg

System Check_Head_5750MHz

DUT: D5GHzV2-SN:1006

Communication System: UID 0, CW (0); Frequency: 5750 MHz;Duty Cycle: 1:1
Medium: HSL_5000 Medium parameters used: $f = 5750$ MHz; $\sigma = 5.361$ S/m; $\epsilon_r = 36.365$; $\rho = 1000$ kg/m³
Ambient Temperature : 23.3 °C ; Liquid Temperature : 22.9 °C

DASY5 Configuration:

- Probe: EX3DV4 - SN3857; ConvF(5.23, 5.23, 5.23); Calibrated: 2018.5.31;
- Sensor-Surface: 1.4mm (Mechanical Surface Detection)
- Electronics: DAE4 Sn1210; Calibrated: 2018.5.28
- Phantom: SAM2; Type: SAM; Serial: TP-1644
- Measurement SW: DASY52, Version 52.8 (8); SEMCAD X Version 14.6.10 (7331)

Pin=100mW/Area Scan (71x71x1): Interpolated grid: dx=1.000 mm, dy=1.000 mm
Maximum value of SAR (interpolated) = 17.8 W/kg

Pin=100mW/Zoom Scan (8x8x7)/Cube 0: Measurement grid: dx=4mm, dy=4mm, dz=1.4mm
Reference Value = 38.43 V/m; Power Drift = 0.04 dB
Peak SAR (extrapolated) = 32.6 W/kg
SAR(1 g) = 7.24 W/kg; SAR(10 g) = 2.07 W/kg
Maximum value of SAR (measured) = 17.8 W/kg

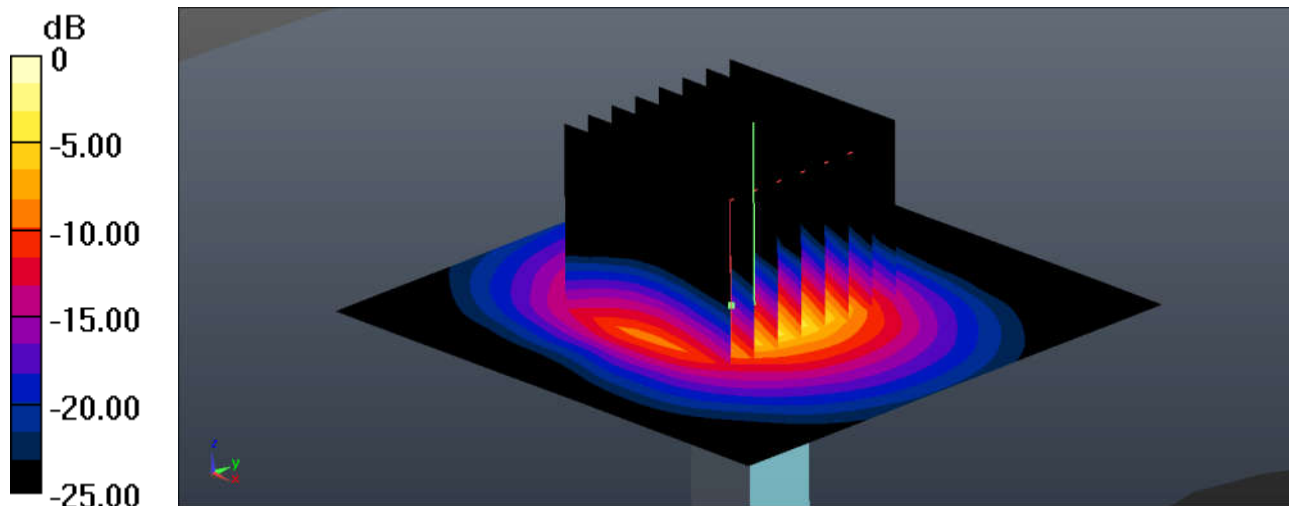

0 dB = 17.8 W/kg = 12.46 dBW/kg

System Check_Body_835MHz

DUT: D835V2 - SN:4d091

Communication System: UID 0, CW; Frequency: 835 MHz; Duty Cycle: 1:1

Medium: MSL_835 Medium parameters used: $f = 835 \text{ MHz}$; $\sigma = 0.984 \text{ S/m}$; $\epsilon_r = 56.51$; $\rho = 1000 \text{ kg/m}^3$

Ambient Temperature : $23.4 \text{ }^\circ\text{C}$; Liquid Temperature : $22.6 \text{ }^\circ\text{C}$

DASY5 Configuration:

- Probe: EX3DV4 - SN3857; ConvF(9.49, 9.49, 9.49); Calibrated: 2018.5.31;
- Sensor-Surface: 1.4mm (Mechanical Surface Detection)
- Electronics: DAE4 Sn1210; Calibrated: 2018.5.28
- Phantom: SAM1; Type: SAM; Serial: TP-1164
- Measurement SW: DASY52, Version 52.8 (8); SEMCAD X Version 14.6.10 (7331)

Pin=250mW/Area Scan (61x61x1): Interpolated grid: $dx=1.500 \text{ mm}$, $dy=1.500 \text{ mm}$

Maximum value of SAR (interpolated) = 3.36 W/kg

Pin=250mW/Zoom Scan (5x5x7)/Cube 0: Measurement grid: $dx=8\text{mm}$, $dy=8\text{mm}$, $dz=5\text{mm}$

Reference Value = 54.11 V/m ; Power Drift = 0.06 dB

Peak SAR (extrapolated) = 3.95 W/kg

SAR(1 g) = 2.57 W/kg ; SAR(10 g) = 1.69 W/kg

Maximum value of SAR (measured) = 3.30 W/kg

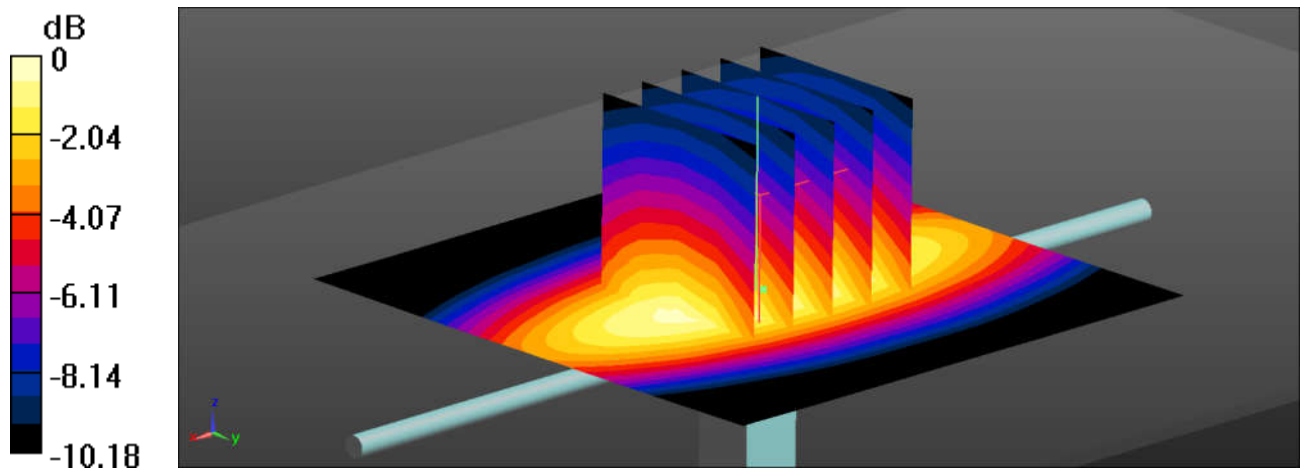

0 dB = $3.30 \text{ W/kg} = 5.19 \text{ dBW/kg}$

System Check_Body_1750MHz

DUT: D1750V2 - SN:1069

Communication System: UID 0, CW (0); Frequency: 1750 MHz; Duty Cycle: 1:1

Medium: MSL_1750 Medium parameters used: $f = 1750$ MHz; $\sigma = 1.491$ S/m; $\epsilon_r = 54.729$; $\rho = 1000$ kg/m³

Ambient Temperature : 23.4 °C ; Liquid Temperature : 22.7 °C

DASY5 Configuration:

- Probe: EX3DV4 - SN3857; ConvF(8.15, 8.15, 8.15); Calibrated: 2018.5.31;
- Sensor-Surface: 1.4mm (Mechanical Surface Detection)
- Electronics: DAE4 Sn1210; Calibrated: 2018.5.28
- Phantom: SAM1; Type: SAM; Serial: TP-1164
- Measurement SW: DASY52, Version 52.8 (8); SEMCAD X Version 14.6.10 (7331)

Pin=250mW/Area Scan (61x61x1): Interpolated grid: dx=1.500 mm, dy=1.500 mm

Maximum value of SAR (interpolated) = 13.2 W/kg

Pin=250mW/Zoom Scan (5x5x7)/Cube 0: Measurement grid: dx=8mm, dy=8mm, dz=5mm

Reference Value = 82.54 V/m; Power Drift = 0.09 dB

Peak SAR (extrapolated) = 16.0 W/kg

SAR(1 g) = 9.34 W/kg; SAR(10 g) = 5.06 W/kg

Maximum value of SAR (measured) = 13.0 W/kg

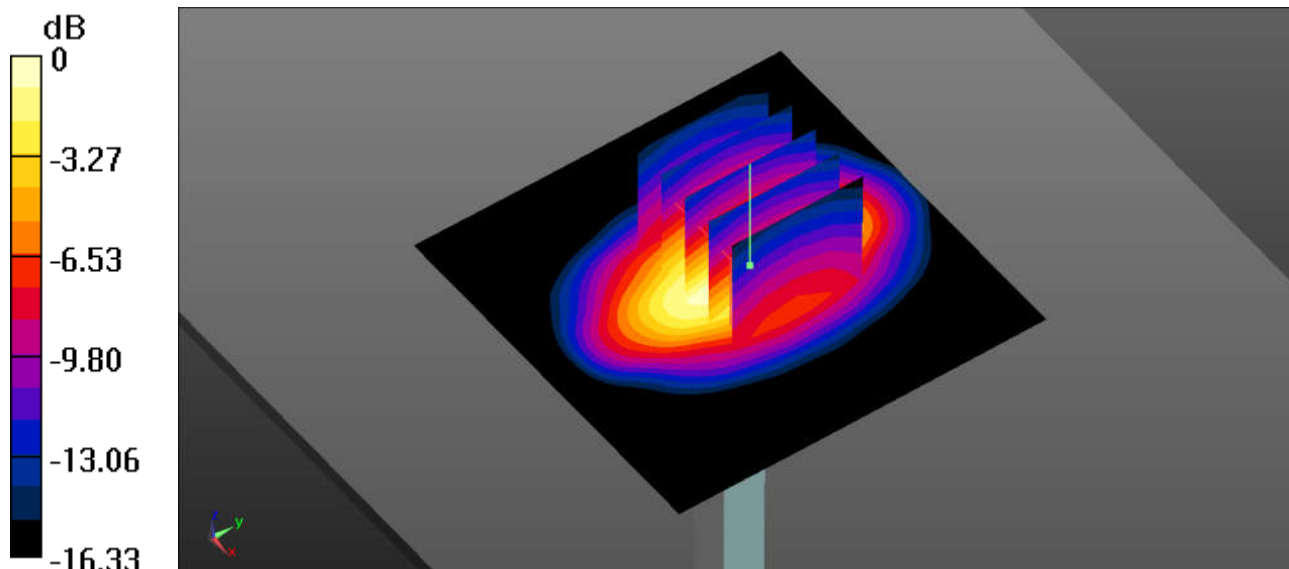

0 dB = 13.0 W/kg = 11.14 dBW/kg

System Check_Body_1900MHz

DUT: D1900V2 - SN:5d118

Communication System: UID 0, CW (0); Frequency: 1900 MHz; Duty Cycle: 1:1
Medium: MSL_1900 Medium parameters used: $f = 1900$ MHz; $\sigma = 1.537$ S/m; $\epsilon_r = 53.469$; $\rho = 1000$ kg/m³
Ambient Temperature : 23.3 °C ; Liquid Temperature : 22.7 °C

DASY5 Configuration:

- Probe: EX3DV4 - SN3857; ConvF(7.82, 7.82, 7.82); Calibrated: 2018.5.31;
- Sensor-Surface: 1.4mm (Mechanical Surface Detection)
- Electronics: DAE4 Sn1210; Calibrated: 2018.5.28
- Phantom: SAM1; Type: SAM; Serial: TP-1164
- Measurement SW: DASY52, Version 52.8 (8); SEMCAD X Version 14.6.10 (7331)

Pin=250mW/Area Scan (61x61x1): Interpolated grid: dx=1.500 mm, dy=1.500 mm
Maximum value of SAR (interpolated) = 13.9 W/kg

Pin=250mW/Zoom Scan (5x5x7)/Cube 0: Measurement grid: dx=8mm, dy=8mm, dz=5mm
Reference Value = 84.90 V/m; Power Drift = 0.07 dB
Peak SAR (extrapolated) = 17.4 W/kg
SAR(1 g) = 9.83 W/kg; SAR(10 g) = 5.13 W/kg
Maximum value of SAR (measured) = 14.0 W/kg

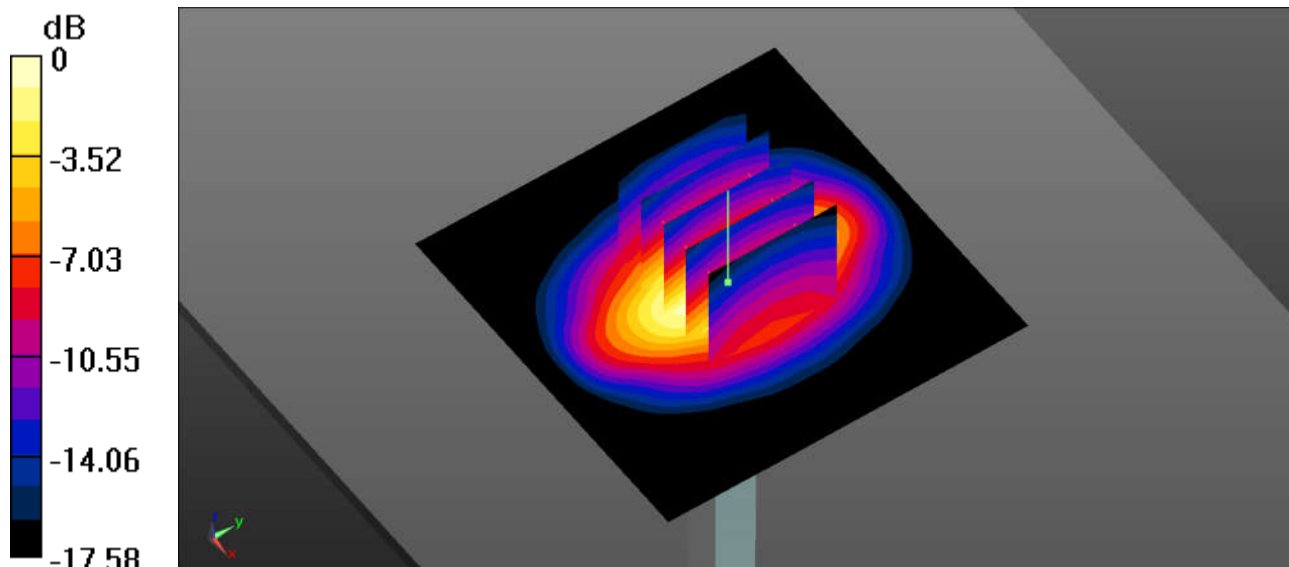

0 dB = 14.0 W/kg = 11.46 dBW/kg

System Check_Body_2450MHz

DUT: D2450V2 - SN:840

Communication System: UID 0, CW; Frequency: 2450 MHz; Duty Cycle: 1:1

Medium: MSL_2450 Medium parameters used: $f = 2450$ MHz; $\sigma = 2.017$ S/m; $\epsilon_r = 53.033$; $\rho = 1000$ kg/m³

Ambient Temperature : 23.4 °C ; Liquid Temperature : 22.9 °C

DASY5 Configuration:

- Probe: EX3DV4 - SN3857; ConvF(7.42, 7.42, 7.42); Calibrated: 2018.5.31;
- Sensor-Surface: 1.4mm (Mechanical Surface Detection)
- Electronics: DAE4 Sn1210; Calibrated: 2018.5.28
- Phantom: SAM1; Type: SAM; Serial: TP-1164
- Measurement SW: DASY52, Version 52.8 (8); SEMCAD X Version 14.6.10 (7331)

Pin=250mW/Area Scan (81x81x1): Interpolated grid: dx=1.200 mm, dy=1.200 mm

Maximum value of SAR (interpolated) = 20.3 W/kg

Pin=250mW/Zoom Scan (7x7x7)/Cube 0: Measurement grid: dx=5mm, dy=5mm, dz=5mm

Reference Value = 88.32 V/m; Power Drift = -0.07 dB

Peak SAR (extrapolated) = 26.7 W/kg

SAR(1 g) = 13.5 W/kg; SAR(10 g) = 6.38 W/kg

Maximum value of SAR (measured) = 20.2 W/kg

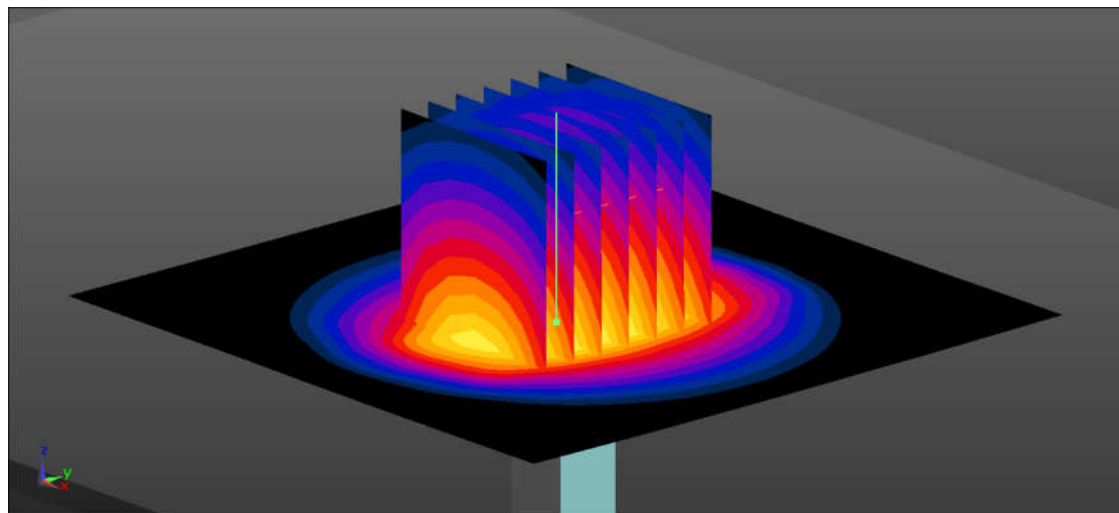
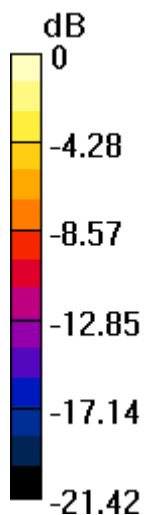

0 dB = 20.2 W/kg = 13.05 dBW/kg

System Check_Body_2600MHz

DUT: D2600V2 - SN:1061

Communication System: UID 0, CW (0); Frequency: 2600 MHz; Duty Cycle: 1:1

Medium: MSL_2600 Medium parameters used: $f = 2600$ MHz; $\sigma = 2.231$ S/m; $\epsilon_r = 52.422$; $\rho = 1000$ kg/m³

Ambient Temperature : 23.5 °C ; Liquid Temperature : 22.6 °C

DASY5 Configuration:

- Probe: EX3DV4 - SN3857; ConvF(7.38, 7.38, 7.38); Calibrated: 2018.5.31;
- Sensor-Surface: 1.4mm (Mechanical Surface Detection)
- Electronics: DAE4 Sn1210; Calibrated: 2018.5.28
- Phantom: SAM1; Type: SAM; Serial: TP-1164
- Measurement SW: DASY52, Version 52.8 (8); SEMCAD X Version 14.6.10 (7331)

Pin=250mW/Area Scan (81x81x1): Interpolated grid: dx=1.200 mm, dy=1.200 mm

Maximum value of SAR (interpolated) = 22.6 W/kg

Pin=250mW/Zoom Scan (7x7x7)/Cube 0: Measurement grid: dx=5mm, dy=5mm, dz=5mm

Reference Value = 88.56 V/m; Power Drift = -0.07 dB

Peak SAR (extrapolated) = 29.8 W/kg

SAR(1 g) = 15 W/kg; SAR(10 g) = 6.71 W/kg

Maximum value of SAR (measured) = 22.5 W/kg

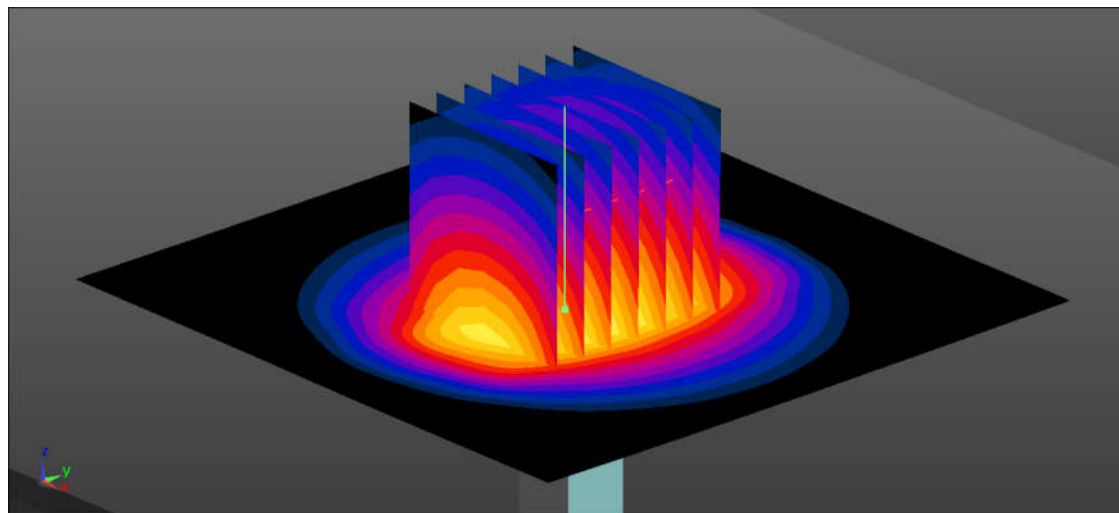
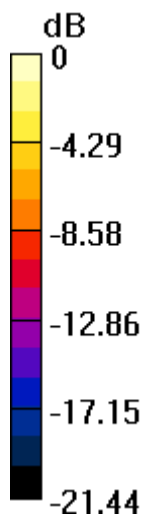

0 dB = 22.5 W/kg = 13.52 dBW/kg

System Check_Body_5250MHz

DUT: D5GHzV2-SN:1006

Communication System: UID 0, CW (0); Frequency: 5250 MHz; Duty Cycle: 1:1
Medium: MSL_5000 3 Medium parameters used: $f = 5250$ MHz; $\sigma = 5.506$ S/m; $\epsilon_r = 47.956$; $\rho = 1000$ kg/m³
Ambient Temperature : 23.3 °C ; Liquid Temperature : 22.6 °C

DASY5 Configuration:

- Probe: EX3DV4 - SN3857; ConvF(4.4, 4.4, 4.4); Calibrated: 2018.5.31;
- Sensor-Surface: 1.4mm (Mechanical Surface Detection)
- Electronics: DAE4 Sn1210; Calibrated: 2018.5.28
- Phantom: SAM1; Type: SAM; Serial: TP-1164
- Measurement SW: DASY52, Version 52.8 (8); SEMCAD X Version 14.6.10 (7331)

Pin=100mW/Area Scan (71x71x1): Interpolated grid: dx=1.000 mm, dy=1.000 mm
Maximum value of SAR (interpolated) = 17.3 W/kg

Pin=100mW/Zoom Scan (8x8x7)/Cube 0: Measurement grid: dx=4mm, dy=4mm, dz=1.4mm
Reference Value = 39.99 V/m; Power Drift = 0.03 dB
Peak SAR (extrapolated) = 26.6 W/kg
SAR(1 g) = 7.72 W/kg; SAR(10 g) = 2.14 W/kg
Maximum value of SAR (measured) = 16.8 W/kg

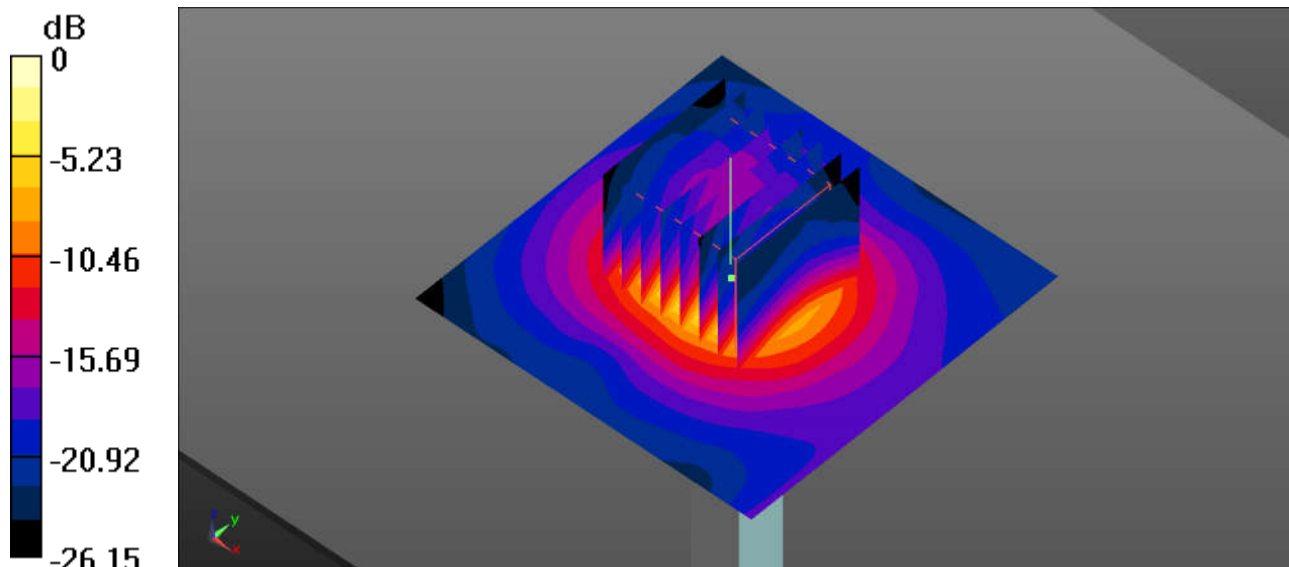

0 dB = 16.8 W/kg = 12.25 dBW/kg