



FCC RF Test Report

APPLICANT : Xiaomi Communications Co., Ltd.
EQUIPMENT : Mobile Phone
BRAND NAME : MI
MODEL NAME : M1806E7TG
FCC ID : 2AFZZ-RMSE7TG
STANDARD : 47 CFR Part 2, 22(H), 27(L), 27(M)
CLASSIFICATION : PCS Licensed Transmitter Held to Ear (PCE)

The product was received on Jun. 26, 2018 and completely tested on Jul. 05, 2018. We, Sporton International (Kunshan) Inc., would like to declare that the tested sample has been evaluated in accordance with the procedures given in ANSI C63.26-2015 and shown compliance with the applicable technical standards.

The test results in this report apply exclusively to the tested model / sample. Without written approval of Sporton International (Kunshan) Inc., the test report shall not be reproduced except in full.

Approved by: James Huang / Manager



Sporton International (Kunshan) Inc.

**No.3-2 Ping-Xiang Rd, Kunshan Development Zone Kunshan City Jiangsu Province 215335
China**



TABLE OF CONTENTS

REVISION HISTORY..... 3
SUMMARY OF TEST RESULT 4
1 GENERAL DESCRIPTION 5
1.1 Applicant 5
1.2 Manufacturer 5
1.3 Product Feature of Equipment Under Test..... 5
1.4 Product Specification of Equipment Under Test..... 6
1.5 Modification of EUT 6
1.6 Maximum ERP/EIRP Power, Frequency Tolerance, and Emission Designator 7
1.7 Testing Location 10
1.8 Applicable Standards..... 10
2 TEST CONFIGURATION OF EQUIPMENT UNDER TEST 11
2.1 Test Mode 11
2.2 Connection Diagram of Test System..... 14
2.3 Support Unit used in test configuration and system 14
2.4 Measurement Results Explanation Example..... 14
2.5 Frequency List of Low/Middle/High Channels 15
3 CONDUCTED TEST ITEMS 17
3.1 Measuring Instruments 17
3.2 Test Setup 17
3.3 Test Result of Conducted Test 17
3.4 Conducted Output Power and ERP/EIRP 18
3.5 Peak-to-Average Ratio 19
3.6 Occupied Bandwidth 20
3.7 Conducted Band Edge 21
3.8 Conducted Spurious Emission 23
3.9 Frequency Stability 24
4 RADIATED TEST ITEMS 25
4.1 Measuring Instruments 25
4.2 Test Setup 25
4.3 Test Result of Radiated Test 25
4.4 Radiated Spurious Emission 26
5 LIST OF MEASURING EQUIPMENT 27
6 UNCERTAINTY OF EVALUATION 28
APPENDIX A. TEST RESULTS OF CONDUCTED TEST
APPENDIX B. TEST RESULTS OF RADIATED TEST
APPENDIX C. TEST SETUP PHOTOGRAPHS



REVISION HISTORY

REPORT NO.	VERSION	DESCRIPTION	ISSUED DATE
FG862604B	Rev. 01	Initial issue of report	Aug. 02, 2018



SUMMARY OF TEST RESULT

Report Section	FCC Rule	Description	Limit	Result	Remark
3.4	§2.1046	Conducted Output Power	Reporting Only	PASS	-
	§22.913(a)(5)	Effective Radiated Power (Band 5)	ERP < 7 Watt	PASS	-
	§27.50(h)(2)	Equivalent Isotropic Radiated Power (Band 7) (Band 38)	EIRP < 2Watt	PASS	-
	§27.50(d)(4)	Equivalent Isotropic Radiated Power (Band 4)	EIRP < 1Watt	PASS	-
3.5	N/A	Peak-to-Average Ratio	<13 dB	PASS	-
3.6	§2.1049	Occupied Bandwidth	Reporting Only	PASS	-
3.7	§2.1051 §22.917(a) §27.53(h)	Conducted Band Edge Measurement (Band 4) (Band 5)	< 43+10log ₁₀ (P[Watts])	PASS	-
	§27.53(m)(4)	Conducted Band Edge Measurement (Band 7) (Band 38)	§27.53(m)(4)		
3.8	§2.1051 §22.917(a) §27.53(h)	Conducted Spurious Emission (Band 4) (Band 5)	< 43+10log ₁₀ (P[Watts])	PASS	-
	§2.1051 §27.53(m)(4)	Conducted Spurious Emission (Band 7) (Band 38)	< 55+10log ₁₀ (P[Watts])		
3.9	§2.1055 §22.355	Frequency Stability Temperature & Voltage	< 2.5 ppm for Part 22	PASS	-
	§2.1055 §27.54		Within Authorized Band		
4.4	§2.1053 §22.917(a) §27.53(h)	Radiated Spurious Emission (Band 4) (Band 5)	< 43+10log ₁₀ (P[Watts])	PASS	Under limit 28.27 dB at 7760.00 MHz
	§2.1053 §27.53(m)(4)	Radiated Spurious Emission (Band 7) (Band 38)	< 55+10log ₁₀ (P[Watts])		



1 General Description

1.1 Applicant

Xiaomi Communications Co., Ltd.

The Rainbow City of China Resources, NO.68, Qinghe Middle Street, Haidian District, Beijing, China

1.2 Manufacturer

Xiaomi Communications Co., Ltd.

The Rainbow City of China Resources, NO.68, Qinghe Middle Street, Haidian District, Beijing, China

1.3 Product Feature of Equipment Under Test

Product Feature	
Equipment	Mobile Phone
Brand Name	MI
Model Name	M1806E7TG
FCC ID	2AFZZ-RMSE7TG
EUT supports Radios application	GSM/GPRS/EGPRS/WCDMA/HSPA/DC-HSDPA/ HSPA+(16QAM uplink is not supported)/LTE WLAN 2.4GHz 802.11b/g/n HT20/HT40/ WLAN 5GHz 802.11a/n HT20/HT40/ WLAN 5GHz 802.11ac VHT20/VHT40/VHT80/ Bluetooth BR/EDR/LE
IMEI Code	Conducted: 868931030100207/868931030104811 Radiation: 868931030107201/868931030107814
HW Version	P2.0
SW Version	MIUI 9
EUT Stage	Identical Prototype



1.4 Product Specification of Equipment Under Test

Standards-related Product Specification	
Tx Frequency	LTE Band 4 : 1710.7 MHz ~ 1754.3 MHz LTE Band 5 : 824.7 MHz ~ 848.3 MHz LTE Band 7 : 2502.5 MHz ~ 2567.5 MHz LTE Band 38 : 2572.5MHz ~ 2617.5MHz
Rx Frequency	LTE Band 4 : 2110.7 MHz ~ 2154.3 MHz LTE Band 5 : 869.7 MHz ~ 893.3 MHz LTE Band 7 : 2622.5MHz ~ 2687.5 MHz LTE Band 38 : 2572.5MHz ~ 2617.5MHz
Bandwidth	LTE Band 4 : 1.4MHz / 3MHz / 5MHz / 10MHz / 15MHz / 20MHz LTE Band 5 : 1.4MHz / 3MHz / 5MHz / 10MHz LTE Band 7 : 5MHz / 10MHz / 15MHz / 20MHz LTE Band 38 : 5MHz / 10MHz / 15MHz / 20MHz
Maximum Output Power to Antenna	LTE Band 4 : 23.27 dBm LTE Band 5 : 22.96 dBm LTE Band 7 : 22.88 dBm LTE Band 38 : 22.90 dBm
Antenna Type	PIFA&Loop Antenna
Antenna Gain	Bottom Antenna: LTE Band 4 : -3.8 dBi LTE Band 5 : -6.2 dBi LTE Band 7 : -2.9 dBi LTE Band 38 : -3.6 dBi
	Top Antenna : LTE Band 4 : -7.3 dBi LTE Band 5 : -9.2 dBi LTE Band 7 : -8.0 dBi LTE Band 38 : -8.0 dBi
Type of Modulation	QPSK / 16QAM / 64QAM

1.5 Modification of EUT

No modifications are made to the EUT during all test items.



1.6 Maximum ERP/EIRP Power, Frequency Tolerance, and Emission Designator

LTE Band 4		QPSK			16QAM		
BW (MHz)	Frequency Range (MHz)	Emission Designator (99%OBW)	Frequency Tolerance (ppm)	Maximum EIRP(W)	Emission Designator (99%OBW)	Frequency Tolerance (ppm)	Maximum EIRP(W)
1.4	1710.7 ~ 1754.3	1M09G7D	-	0.0832	1M09W7D	-	0.0714
3	1711.5 ~ 1753.5	2M73G7D	-	0.0826	2M75W7D	-	0.0719
5	1712.5 ~ 1752.5	4M50G7D	-	0.0865	4M52W7D	-	0.0703
10	1715.0 ~ 1750.0	9M07G7D	0.0040	0.0849	9M03W7D	-	0.0793
15	1717.5 ~ 1747.5	13M5G7D	-	0.0883	13M4W7D	-	0.0764
20	1720.0 ~ 1745.0	18M5G7D	-	0.0885	18M3W7D	-	0.0771
LTE Band 4		64QAM					
BW (MHz)	Frequency Range (MHz)	Emission Designator (99%OBW)		Frequency Tolerance (ppm)		Maximum EIRP(W)	
1.4	1710.7 ~ 1754.3	1M09W7D		-		0.0586	
3	1711.5 ~ 1753.5	2M73W7D		-		0.0736	
5	1712.5 ~ 1752.5	4M50W7D		-		0.0718	
10	1715.0 ~ 1750.0	9M05W7D		-		0.0766	
15	1717.5 ~ 1747.5	13M5W7D		-		0.0604	
20	1720.0 ~ 1745.0	18M5W7D		-		0.0603	
LTE Band 5		QPSK			16QAM		
BW (MHz)	Frequency Range (MHz)	Emission Designator (99%OBW)	Frequency Tolerance (ppm)	Maximum ERP(W)	Emission Designator (99%OBW)	Frequency Tolerance (ppm)	Maximum ERP(W)
1.4	824.7 ~ 848.3	1M09G7D	-	0.0286	1M09W7D	-	0.0248
3	825.5 ~ 847.5	2M72G7D	-	0.0288	2M74W7D	-	0.0251
5	826.5 ~ 846.5	4M51G7D	-	0.0288	4M50W7D	-	0.0248
10	829.0 ~ 844.0	9M05G7D	0.0060	0.0289	9M05W7D	-	0.0248
LTE Band 5		64QAM					
BW (MHz)	Frequency Range (MHz)	Emission Designator (99%OBW)		Frequency Tolerance (ppm)		Maximum ERP(W)	
1.4	824.7 ~ 848.3	1M09W7D		-		0.0239	
3	825.5 ~ 847.5	2M73W7D		-		0.0245	
5	826.5 ~ 846.5	4M49W7D		-		0.0241	
10	829.0 ~ 844.0	9M05W7D		-		0.0242	



LTE Band 7		QPSK			16QAM		
BW (MHz)	Frequency Range (MHz)	Emission Designator (99%OBW)	Frequency Tolerance (ppm)	Maximum EIRP(W)	Emission Designator (99%OBW)	Frequency Tolerance (ppm)	Maximum EIRP(W)
5	2502.5 ~ 2567.5	4M50G7D	-	0.0989	4M50W7D	-	0.0836
10	2505.0 ~ 2565.0	9M01G7D	0.0024	0.0991	9M03W7D	-	0.0834
15	2507.5 ~ 2562.5	13M5G7D	-	0.0993	13M4W7D	-	0.0843
20	2510.0 ~ 2560.0	18M4G7D	-	0.0995	18M3W7D	-	0.0839
LTE Band 7		64QAM					
BW (MHz)	Frequency Range (MHz)	Emission Designator (99%OBW)		Frequency Tolerance (ppm)	Maximum EIRP(W)		
5	2502.5 ~ 2567.5	4M51W7D		-	0.0656		
10	2505.0 ~ 2565.0	9M09W7D		-	0.0652		
15	2507.5 ~ 2562.5	13M5W7D		-	0.0662		
20	2510.0 ~ 2560.0	18M3W7D		-	0.0658		
LTE Band 38		QPSK			16QAM		
BW (MHz)	Frequency Range (MHz)	Emission Designator (99%OBW)	Frequency Tolerance (ppm)	Maximum EIRP(W)	Emission Designator (99%OBW)	Frequency Tolerance (ppm)	Maximum EIRP(W)
5	2572.5 ~ 2617.5	4M50G7D	-	0.0834	4M51W7D	-	0.0685
10	2575.0 ~ 2615.0	9M03G7D	0.0020	0.0849	9M07W7D	-	0.0689
15	2577.5 ~ 2612.5	13M6G7D	-	0.0847	13M4W7D	-	0.0698
20	2580.0 ~ 2610.0	18M4G7D	-	0.0851	18M5W7D	-	0.0697
LTE Band 38		64QAM					
BW (MHz)	Frequency Range (MHz)	Emission Designator (99%OBW)		Frequency Tolerance (ppm)	Maximum EIRP(W)		
5	2572.5 ~ 2617.5	4M52W7D		-	0.0516		
10	2575.0 ~ 2615.0	9M05W7D		-	0.0519		
15	2577.5 ~ 2612.5	13M5W7D		-	0.0518		
20	2580.0 ~ 2610.0	18M4W7D		-	0.0522		



LTE Band 7 CA	QPSK			16QAM		
BW (MHz)	Emission Designator (99%OBW)	Frequency Tolerance (ppm)	Maximum EIRP(W)	Emission Designator (99%OBW)	Frequency Tolerance (ppm)	Maximum EIRP(W)
10MHz+20MHz	28M1G7D	-	0.1153	28M1W7D	-	0.1014
15MHz+15MHz	28M7G7D	-	0.1161	28M7W7D	-	0.0916
15MHz+20MHz	32M9G7D	-	0.1202	33M0W7D	-	0.1005
15MHz+10MHz	23M5G7D	-	0.1102	23M5W7D	-	0.0968
20MHz+10MHz	28M2G7D	-	0.1164	28M1W7D	-	0.1014
20MHz+15MHz	33M0G7D	-	0.1191	32M9W7D	-	0.0993
20MHz+20MHz	37M6G7D	-	0.1127	37M8W7D	-	0.0979
LTE Band 7 CA	64QAM					
BW (MHz)	Emission Designator (99%OBW)		Frequency Tolerance (ppm)		Maximum EIRP(W)	
10MHz+20MHz	27M9W7D		-		0.0968	
15MHz+15MHz	28M6W7D		-		0.0933	
15MHz+20MHz	32M7W7D		-		0.0975	
15MHz+10MHz	23M5W7D		-		0.0889	
20MHz+10MHz	28M1W7D		-		0.0991	
20MHz+15MHz	32M9W7D		-		0.0951	
20MHz+20MHz	37M7W7D		-		0.0951	
LTE Band 38 CA	QPSK			16QAM		
BW (MHz)	Emission Designator (99%OBW)	Frequency Tolerance (ppm)	Maximum EIRP(W)	Emission Designator (99%OBW)	Frequency Tolerance (ppm)	Maximum EIRP(W)
15MHz+15MHz	28M7G7D	-	0.0995	28M7W7D	-	0.0843
20MHz+20MHz	37M8G7D	-	0.0975	37M9W7D	-	0.0859
LTE Band 38 CA	64QAM					
BW (MHz)	Emission Designator (99%OBW)		Frequency Tolerance (ppm)		Maximum EIRP(W)	
15MHz+15MHz	28M7W7D		-		0.0791	
20MHz+20MHz	37M8W7D		-		0.0843	



1.7 Testing Location

Sporton International (Kunshan) Inc. is accredited to ISO 17025 by National Voluntary Laboratory Accreditation Program (NVLAP code: 600155-0) and the FCC designation No is CN5013.

Test Site	Sporton International (Kunshan) Inc.		
Test Site Location	No.3-2 Ping-Xiang Rd, Kunshan Development Zone Kunshan City Jiangsu Province 215335 China TEL : +86-512-57900158 FAX : +86-512-57900958		
Test Site No.	Sporton Site No.		FCC Test Firm Registration No.
	TH01-KS	03CH02-KS	630927

Note: The test site complies with ANSI C63.4 2014 requirement.

1.8 Applicable Standards

According to the specifications of the manufacturer, the EUT must comply with the requirements of the following standards:

- ♦ 47 CFR Part 2, 22(H), 27(L), 27(M)
- ♦ ANSI C63.26-2015
- ♦ FCC KDB 971168 D01 Power Meas License Digital Systems v03r01
- ♦ FCC KDB 412172 D01 Determining ERP and EIRP v01r01

Remark:

1. All test items were verified and recorded according to the standards and without any deviation during the test.
2. This EUT has also been tested and complied with the requirements of FCC Part 15, Subpart B, recorded in a separate test report.



2 Test Configuration of Equipment Under Test

2.1 Test Mode

Antenna port conducted and radiated test items listed below are performed according to KDB 971168 D01 Power Meas License Digital Systems v03r01 with maximum output power.

Radiated measurements are performed by rotating the EUT in three different orthogonal test planes to find the maximum emission.

Test Items	Band	Bandwidth (MHz)						Modulation			RB #			Test Channel		
		1.4	3	5	10	15	20	QPSK	16QAM	64QAM	1	Half	Full	L	M	H
Max. Output Power	4	v	v	v	v	v	v	v	v	v	v	v	v	v	v	v
	5	v	v	v	v	-	-	v	v	v	v	v	v	v	v	v
	7	-	-	v	v	v	v	v	v	v	v	v	v	v	v	v
	38	-	-	v	v	v	v	v	v	v	v	v	v	v	v	v
Peak-to-Average Ratio	4						v	v	v	v	v		v	v	v	v
	5				v	-	-	v	v	v	v		v	v	v	v
	7	-	-				v	v	v	v	v		v	v	v	v
	38	-	-				v	v	v	v	v		v	v	v	v
26dB and 99% Bandwidth	4	v	v	v	v	v	v	v	v	v			v	v	v	v
	5	v	v	v	v	-	-	v	v	v			v	v	v	v
	7	-	-	v	v	v	v	v	v	v			v	v	v	v
	38	-	-	v	v	v	v	v	v	v			v	v	v	v
Conducted Band Edge	4	v	v	v	v	v	v	v	v	v	v		v	v		v
	5	v	v	v	v	-	-	v	v	v	v		v	v		v
	7	-	-	v	v	v	v	v	v	v	v		v	v		v
	38	-	-	v	v	v	v	v	v	v	v		v	v		v



Test Items	Band	Bandwidth (MHz)						Modulation			RB #			Test Channel		
		1.4	3	5	10	15	20	QPSK	16QAM	64QAM	1	Half	Full	L	M	H
Conducted Spurious Emission	4	v	v	v	v	v	v	v	v	v	v			v	v	v
	5	v	v	v	v	-	-	v	v	v	v			v	v	v
	7	-	-	v	v	v	v	v	v	v	v			v	v	v
	38	-	-	v	v	v	v	v	v	v	v			v	v	v
Frequency Stability	4				v			v					v		v	
	5				v	-	-	v					v		v	
	7	-	-		v			v					v		v	
	38	-	-		v			v					v		v	
E.R.P / E.I.R.P	4	v	v	v	v	v	v	v	v	v	v			v	v	v
	5	v	v	v	v	-	-	v	v	v	v			v	v	v
	7	-	-	v	v	v	v	v	v	v	v			v	v	v
	38	-	-	v	v	v	v	v	v	v	v			v	v	v
Radiated Spurious Emission	4	Worst Case												v		
	5	Worst Case												v		
	7	Worst Case												v		
	38	Worst Case												v		
Note	<ol style="list-style-type: none"> The mark "v" means that this configuration is chosen for testing The mark "-" means that this bandwidth is not supported. The device is investigated from 30MHz to 10 times of fundamental signal for radiated spurious emission test under different RB size/offset and modulations in exploratory test. Subsequently, only the worst case emissions are reported. For the test item of ERP/EIRP, we only assess the max antenna gain from Antenna 1 and Antenna 2 For the test items of Radiated Spurious Emission, we assess both Antenna. 															



Test Items	Band	Bandwidth (MHz)									Modulation			RB #			Test Channel				
		20+20	20+15	15+20	20+10	10+20	20+5	5+20	15+15	15+10	10+15	QPSK	16QAM	64QAM	1	Half	Full	L	M	H	
26dB and 99% Bandwidth	7_CA	v	v	v	v	v	-	-	v	v	-	v	v	v			v	v	v	v	
	38_CA	v	-	-	-	-	-	-	v	-	-	v	v	v			v	v	v	v	
Conducted Band Edge	7_CA	v	v	v	v	v	-	-	v	v	-	v	v	v	v		v	v		v	
	38_CA	v	-	-	-	-	-	-	v	-	-	v	v	v	v		v	v		v	
Conducted Spurious Emission	7_CA	v	v	v	v	v	-	-	v	v	-	v	v	v	v			v	v	v	
	38_CA	v	-	-	-	-	-	-	v	-	-	v	v	v	v			v	v	v	
E.I.R.P.	7_CA	v	v	v	v	v	-	-	v	v	-	v	v	v	v			v	v	v	
	38_CA	v	-	-	-	-	-	-	v	-	-	v	v	v	v			v	v	v	
Radiated Spurious Emission	7_CA	Worst Case																		v	
	38_CA	Worst Case																		v	
Note	<ol style="list-style-type: none"> The mark "v" means that this configuration is chosen for testing The mark "-" means that this bandwidth is not supported. The device is investigated from 30MHz to 10 times of fundamental signal for radiated spurious emission test under different RB size/offset and modulations in exploratory test. Subsequently, only the worst case emissions are reported. For the test item of ERP/EIRP, we only assess the max antenna gain from Antenna 1 and Antenna 2 For the test items of Radiated Spurious Emission, we assess both Antenna. 																				

2.2 Connection Diagram of Test System

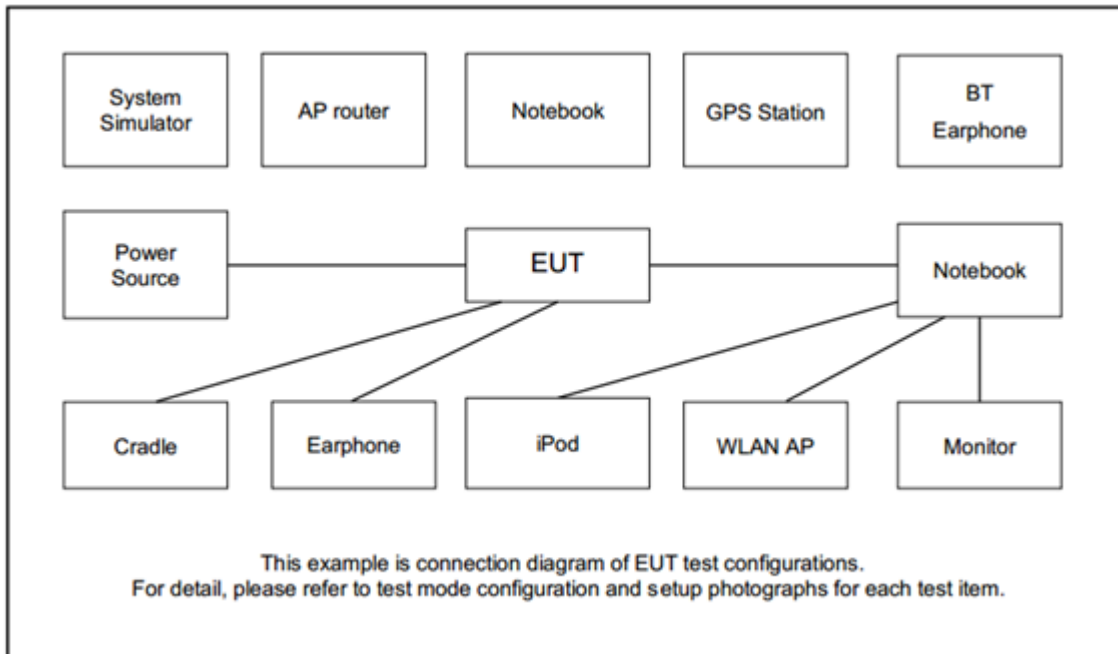

2.3 Support Unit used in test configuration and system

Item	Equipment	Trade Name	Model No.	FCC ID	Data Cable	Power Cord
1.	DC Power Supply	GW	GPS-3030D	N/A	N/A	Unshielded, 1.8 m
2.	LTE Base Station	Anritsu	MT8820C	N/A	N/A	Unshielded, 1.8 m

2.4 Measurement Results Explanation Example

For all conducted test items:

The offset level is set in the spectrum analyzer to compensate the RF cable loss between EUT conducted output port and spectrum analyzer. With the offset compensation, the spectrum analyzer reading level is exactly the EUT RF output level.

The spectrum analyzer offset is derived from RF cable loss.

Offset = RF cable loss.

Following shows an offset computation example with cable loss 5.3 dB.

Example :

$$\begin{aligned} \text{Offset(dB)} &= \text{RF cable loss(dB)} \\ &= 5.3 \text{ (dB)} \end{aligned}$$



2.5 Frequency List of Low/Middle/High Channels

LTE Band 4 Channel and Frequency List				
BW [MHz]	Channel/Frequency(MHz)	Lowest	Middle	Highest
20	Channel	20050	20175	20300
	Frequency	1720	1732.5	1745
15	Channel	20025	20175	20325
	Frequency	1717.5	1732.5	1747.5
10	Channel	20000	20175	20350
	Frequency	1715	1732.5	1750
5	Channel	19975	20175	20375
	Frequency	1712.5	1732.5	1752.5
3	Channel	19965	20175	20385
	Frequency	1711.5	1732.5	1753.5
1.4	Channel	19957	20175	20393
	Frequency	1710.7	1732.5	1754.3

LTE Band 5 Channel and Frequency List				
BW [MHz]	Channel/Frequency(MHz)	Lowest	Middle	Highest
10	Channel	20450	20525	20600
	Frequency	829	836.5	844
5	Channel	20425	20525	20625
	Frequency	826.5	836.5	846.5
3	Channel	20415	20525	20635
	Frequency	825.5	836.5	847.5
1.4	Channel	20407	20525	20643
	Frequency	824.7	836.5	848.3



LTE Band 7 Channel and Frequency List				
BW [MHz]	Channel/Frequency(MHz)	Lowest	Middle	Highest
20	Channel	20850	21100	21350
	Frequency	2510	2535	2560
15	Channel	20825	21100	21375
	Frequency	2507.5	2535	2562.5
10	Channel	20800	21100	21400
	Frequency	2505	2535	2565
5	Channel	20775	21100	21425
	Frequency	2502.5	2535	2567.5

LTE Band 38 Channel and Frequency List				
BW [MHz]	Channel/Frequency(MHz)	Lowest	Middle	Highest
20	Channel	37850	38000	38150
	Frequency	2580	2595	2610
15	Channel	37825	38000	38175
	Frequency	2577.5	2595	2612.5
10	Channel	37800	38000	38200
	Frequency	2575	2595	2615
5	Channel	37775	38000	38225
	Frequency	2572.5	2595	2617.5

3 Conducted Test Items

3.1 Measuring Instruments

See list of measuring instruments of this test report.

3.2 Test Setup

3.2.1 Conducted Output Power



3.2.2 Peak-to-Average Ratio, Occupied Bandwidth ,Conducted Band-Edge and Conducted Spurious Emission

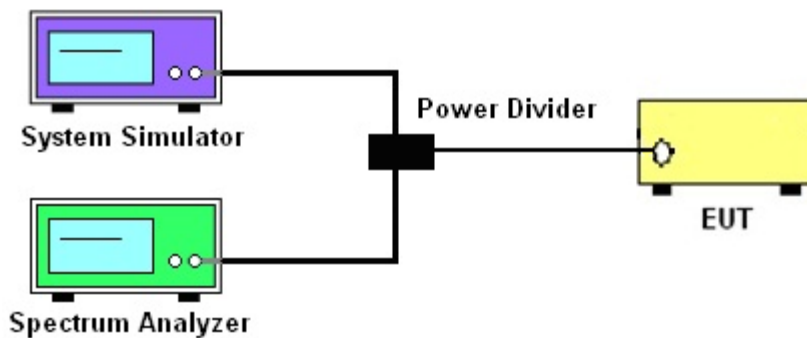

3.2.3 Frequency Stability

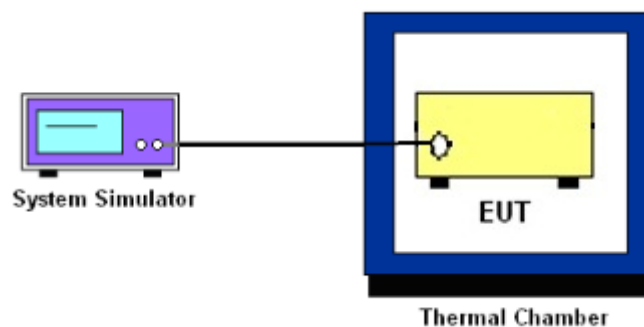

3.3 Test Result of Conducted Test

Please refer to Appendix A.



3.4 Conducted Output Power and ERP/EIRP

3.4.1 Description of the Conducted Output Power Measurement and ERP/EIRP Measurement

A system simulator was used to establish communication with the EUT. Its parameters were set to force the EUT transmitting at maximum output power. The measured power in the radio frequency on the transmitter output terminals shall be reported.

The ERP of mobile transmitters must not exceed 7 Watts for LTE Band 5.

The EIRP of mobile transmitters must not exceed 2 Watts for LTE Band 7 and Band 38.

The EIRP of mobile transmitters must not exceed 1 Watts for LTE Band 4.

According to KDB 412172 D01 Power Approach,

$EIRP = P_T + G_T - L_C$, $ERP = EIRP - 2.15$, where

P_T = transmitter output power in dBm

G_T = gain of the transmitting antenna in dBi

L_C = signal attenuation in the connecting cable between the transmitter and antenna in dB

3.4.2 Test Procedures

1. The testing follows ANSI C63.26 Section 5.2
2. The transmitter output port was connected to the system simulator.
3. Set EUT at maximum power through the system simulator.
4. Select lowest, middle, and highest channels for each band and different modulation.
5. Measure and record the power level from the system simulator.



3.5 Peak-to-Average Ratio

3.5.1 Description of the PAR Measurement

Power Complementary Cumulative Distribution Function (CCDF) curves provide a means for characterizing the power peaks of a digitally modulated signal on a statistical basis. A CCDF curve depicts the probability of the peak signal amplitude exceeding the average power level. Most contemporary measurement instrumentation include the capability to produce CCDF curves for an input signal provided that the instrument's resolution bandwidth can be set wide enough to accommodate the entire input signal bandwidth. In measuring transmissions in this band using an average power technique, the peak-to-average ratio (PAR) of the transmission may not exceed 13 dB.

3.5.2 Test Procedures

1. The testing follows ANSI C63.26 Section 5.2.3.4 (CCDF).
2. The EUT was connected to spectrum and system simulator via a power divider.
3. Set the CCDF (Complementary Cumulative Distribution Function) option in spectrum analyzer.
4. The highest RF powers were measured and recorded the maximum PAPR level associated with a probability of 0.1 %.
5. Record the deviation as Peak to Average Ratio.



3.6 Occupied Bandwidth

3.6.1 Description of Occupied Bandwidth Measurement

The occupied bandwidth is the width of a frequency band such that, below the lower and above the upper frequency limits, the mean powers emitted are each equal to a specified percentage 0.5% of the total mean transmitted power.

The 26 dB emission bandwidth is defined as the frequency range between two points, one above and one below the carrier frequency, at which the spectral density of the emission is attenuated 26 dB below the maximum in-band spectral density of the modulated signal. Spectral density (power per unit bandwidth) is to be measured with a detector of resolution bandwidth equal to approximately 1.0% of the emission bandwidth.

3.6.2 Test Procedures

1. The testing follows ANSI C63.26 Section 5.4
2. The EUT was connected to spectrum analyzer and system simulator via a power divider.
3. The spectrum analyzer center frequency is set to the nominal EUT channel center frequency. The span range for the spectrum analyzer shall be between two and five times the anticipated OBW.
4. The nominal resolution bandwidth (RBW) shall be in the range of 1 to 5 % of the anticipated OBW, and the VBW shall be at least 3 times the RBW.
5. Set the detection mode to peak, and the trace mode to max hold.
6. Determine the reference value: Set the EUT to transmit a modulated signal. Allow the trace to stabilize. Set the spectrum analyzer marker to the highest level of the displayed trace.
(this is the reference value)
7. Determine the “-26 dB down amplitude” as equal to (Reference Value – X).
8. Place two markers, one at the lowest and the other at the highest frequency of the envelope of the spectral display such that each marker is at or slightly below the “-X dB down amplitude” determined in step 6. If a marker is below this “-X dB down amplitude” value it shall be placed as close as possible to this value. The OBW is the positive frequency difference between the two markers.
9. Use the 99 % power bandwidth function of the spectrum analyzer and report the measured bandwidth.



3.7 Conducted Band Edge

3.7.1 Description of Conducted Band Edge Measurement

22.917(a)

For operations in the 824 – 849 MHz band, the FCC limit is $43 + 10\log_{10}(P[\text{Watts}])$ dB below the transmitter power $P(\text{Watts})$ in a 100kHz bandwidth. However, in the 1MHz bands immediately outside and adjacent to the licensee's frequency block, a resolution bandwidth of at least one percent of the emission bandwidth of the fundamental emission of the transmitter may be employed.

27.53 (h)

For operations in the 1710 – 1755 MHz band, the FCC limit is $43 + 10\log_{10}(P[\text{Watts}])$ dB below the transmitter power $P(\text{Watts})$ in a 1 MHz bandwidth. However, in the 1MHz bands immediately outside and adjacent to the licensee's frequency block, a resolution bandwidth of at least one percent of the emission bandwidth of the fundamental emission of the transmitter may be employed.

27.53(m)(4)

For mobile digital stations, the attenuation factor shall be not less than $40 + 10 \log (P)$ dB on all frequencies between the channel edge and 5 megahertz from the channel edge, $43 + 10 \log (P)$ dB on all frequencies between 5 megahertz and X megahertz from the channel edge, and $55 + 10 \log (P)$ dB on all frequencies more than X megahertz from the channel edge, where X is the greater of 6 megahertz or the actual emission bandwidth as defined in paragraph (m)(6) of this section. In addition, the attenuation factor shall not be less that $43 + 10 \log (P)$ dB on all frequencies between 2490.5 MHz and 2496 MHz and $55 + 10 \log (P)$ dB at or below 2490.5 MHz. Mobile Satellite Service licensees operating on frequencies below 2495 MHz may also submit a documented interference complaint against BRS licensees operating on channel BRS Channel 1 on the same terms and conditions as adjacent channel BRS or EBS licensees.



3.7.2 Test Procedures

1. The testing follows ANSI C63.26 section 5.7
2. The EUT was connected to spectrum analyzer and system simulator via a power divider.
3. The band edges of low and high channels for the highest RF powers were measured.
4. Set RBW \geq 1% EBW in the 1MHz band immediately outside and adjacent to the band edge.
5. Beyond the 1 MHz band from the band edge, RBW=1MHz was used.
6. Set spectrum analyzer with RMS detector.
7. The RF fundamental frequency should be excluded against the limit line in the operating frequency band.
8. Checked that all the results comply with the emission limit line.

Example:

The limit line is derived from $43 + 10\log(P)$ dB below the transmitter power P(Watts)

$$= P(W) - [43 + 10\log(P)] \text{ (dB)}$$

$$= [30 + 10\log(P)] \text{ (dBm)} - [43 + 10\log(P)] \text{ (dB)} = -13\text{dBm}.$$

9. For LTE Band 7, 38, the other 40 dB, and 55 dB have additionally applied same calculation above.



3.8 Conducted Spurious Emission

3.8.1 Description of Conducted Spurious Emission Measurement

The power of any emission outside of the authorized operating frequency ranges must be lower than the transmitter power (P) by a factor of at least $43 + 10 \log (P)$ dB.

For Band 7,38:

The power of any emission outside of the authorized operating frequency ranges must be lower than the transmitter power (P) by a factor of at least $55 + 10 \log (P)$ dB.

It is measured by means of a calibrated spectrum analyzer and scanned from 30 MHz up to a frequency including its 10th harmonic.

3.8.2 Test Procedures

1. The testing follows ANSI C63.26 section 5.7
2. The EUT was connected to spectrum analyzer and system simulator via a power divider.
3. The RF output of EUT was connected to the spectrum analyzer by RF cable and attenuator. The path loss was compensated to the results for each measurement.
4. The middle channel for the highest RF power within the transmitting frequency was measured.
5. The conducted spurious emission for the whole frequency range was taken.
6. Make the measurement with the spectrum analyzer's RBW = 1MHz, VBW = 3MHz.
7. Set spectrum analyzer with RMS detector.
8. Taking the record of maximum spurious emission.
9. The RF fundamental frequency should be excluded against the limit line in the operating frequency band.
10. The limit line is derived from $43 + 10\log(P)$ dB below the transmitter power P(Watts)
 $= P(W) - [43 + 10\log(P)]$ (dB)
 $= [30 + 10\log(P)]$ (dBm) - $[43 + 10\log(P)]$ (dB)
 $= -13$ dBm.
11. For Band 7, 38
The limit line is derived from $55 + 10\log(P)$ dB below the transmitter power P(Watts)
 $= P(W) - [55 + 10\log(P)]$ (dB)
 $= [30 + 10\log(P)]$ (dBm) - $[55 + 10\log(P)]$ (dB)
 $= -25$ dBm.



3.9 Frequency Stability

3.9.1 Description of Frequency Stability Measurement

The frequency stability shall be measured by variation of ambient temperature and variation of primary supply voltage to ensure that the fundamental emission stays within the authorized frequency block. The frequency stability of the transmitter shall be maintained within $\pm 0.00025\%$ ($\pm 2.5\text{ppm}$) of the center frequency.

3.9.2 Test Procedures for Temperature Variation

1. The testing follows ANSI C63.26 section 5.6.4
2. The EUT was set up in the thermal chamber and connected with the system simulator.
3. With power OFF, the temperature was decreased to -30°C and the EUT was stabilized before testing. Power was applied and the maximum change in frequency was recorded within one minute.
4. With power OFF, the temperature was raised in 10°C step up to 50°C . The EUT was stabilized at each step for at least half an hour. Power was applied and the maximum frequency change was recorded within one minute.

3.9.3 Test Procedures for Voltage Variation

1. The testing follows ANSI C63.26 section 5.6.5
2. The EUT was placed in a temperature chamber at $20\pm 5^{\circ}\text{C}$ and connected with the system simulator.
3. The power supply voltage to the EUT was varied from 85% to 115% of the nominal value for other than hand carried battery equipment.
4. For hand carried, battery powered equipment, reduce the primary ac or dc supply voltage to the battery operating end point, which shall be specified by the manufacturer.
5. The variation in frequency was measured for the worst case.

4 Radiated Test Items

4.1 Measuring Instruments

See list of measuring instruments of this test report.

4.2 Test Setup

4.2.1 For radiated test from 30MHz to 1GHz



4.2.2 For radiated test above 1GHz

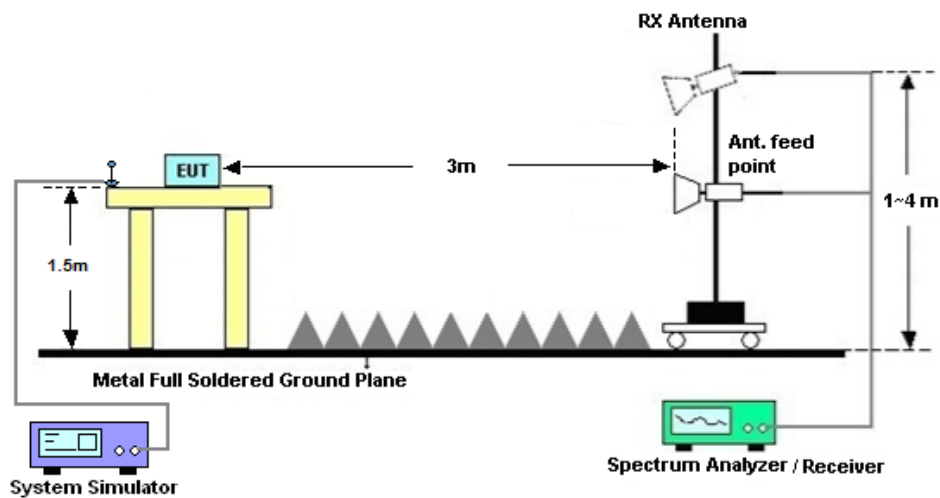

4.3 Test Result of Radiated Test

Please refer to Appendix B.



4.4 Radiated Spurious Emission

4.4.1 Description of Radiated Spurious Emission

The radiated spurious emission was measured by substitution method according to ANSI C63.26. The power of any emission outside of the authorized operating frequency ranges must be attenuated below the transmitter power (P) by a factor of at least $43 + 10 \log (P)$ dB.

For Band 7, 38

The power of any emission outside of the authorized operating frequency ranges must be attenuated below the transmitter power (P) by a factor of at least $55 + 10 \log (P)$ dB.

The spectrum is scanned from 30 MHz up to a frequency including its 10th harmonic.

4.4.2 Test Procedures

1. The testing follows ANSI C63.26 Section 5.5
2. The EUT was placed on a turntable with 0.8 meter height for frequency below 1GHz and 1.5 meter height for frequency above 1GHz respectively above ground.
3. The EUT was set 3 meters from the receiving antenna mounted on the antenna tower.
4. The table was rotated 360 degrees to determine the position of the highest spurious emission.
5. The height of the receiving antenna is varied between 1m to 4m to search the maximum spurious emission for both horizontal and vertical polarizations.
6. During the measurement, the system simulator parameters were set to force the EUT transmitting at maximum output power.
7. Make the measurement with the spectrum analyzer's RBW = 1MHz, VBW = 3MHz, taking the record of maximum spurious emission.
8. A horn antenna was substituted in place of the EUT and was driven by a signal generator.
9. Tune the output power of signal generator to the same emission level with EUT maximum spurious emission.
10. $EIRP (dBm) = S.G. Power - Tx Cable Loss + Tx Antenna Gain$
11. $ERP (dBm) = EIRP - 2.15$
12. The RF fundamental frequency should be excluded against the limit line in the operating frequency band.

The limit line is derived from $43 + 10\log(P)$ dB below the transmitter power P(Watts)
 $= P(W) - [43 + 10\log(P)] (dB)$
 $= [30 + 10\log(P)] (dBm) - [43 + 10\log(P)] (dB)$
 $= -13dBm.$

13. For Band 7, 38:

The limit line is derived from $55 + 10\log(P)$ dB below the transmitter power P(Watts)



5 List of Measuring Equipment

Instrument	Manufacturer	Model No.	Serial No.	Characteristics	Calibration Date	Test Date	Due Date	Remark
Spectrum Analyzer	R&S	FSV40	101040	10Hz~40GHz	Aug. 08, 2017	Jun. 29, 2018~ Jul. 05, 2018	Aug. 07, 2018	Conducted (TH01-KS)
Radio communication analyzer	Anritsu	MT8820C	6201300652	2G/3G/LTE_ full band	Aug. 08, 2017	Jun. 29, 2018~ Jul. 05, 2018	Aug. 07, 2018	Conducted (TH01-KS)
Thermal Chamber	Ten Billion	TTC-B3S	TBN-960502	-40~+150°C	Oct. 12, 2017	Jun. 29, 2018~ Jul. 05, 2018	Oct. 11, 2018	Conducted (TH01-KS)
EMI Test Receiver	R&S	ESR7	101403	9kHz~7GHz;Max 30dBm	Aug. 08, 2017	Jul. 05, 2018~ Jul. 11, 2018	Aug. 07, 2018	Radiation (03CH02-KS)
EXA Spectrum Analyzer	Keysight	N9010A	MY55150208	10Hz-44G,MAX 30dB	Apr. 17, 2018	Jul. 05, 2018~ Jul. 11, 2018	Apr. 16, 2019	Radiation (03CH02-KS)
Bilog Antenna	TeseQ	CBL6112D	23182	30MHz-2GHz	Jan. 29, 2018	Jul. 05, 2018~ Jul. 11, 2018	Jan. 28, 2019	Radiation (03CH02-KS)
Double Ridge Horn Antenna	ETS-Lindgren	3117	75957	1GHz~18GHz	Oct. 21, 2017	Jul. 05, 2018~ Jul. 11, 2018	Oct. 20, 2018	Radiation (03CH02-KS)
SHF-EHF Horn	Schwarzbeck	BBHA 9170	BBHA170249	15GHz~40GHz	Feb. 07, 2018	Jul. 05, 2018~ Jul. 11, 2018	Feb. 06, 2019	Radiation (03CH02-KS)
Amplifier	SONOMA	310N	187289	9KHz-1GHz	Aug. 07, 2017	Jul. 05, 2018~ Jul. 11, 2018	Aug. 06, 2018	Radiation (03CH02-KS)
high gain Amplifier	MITEQ	AMF-7D-00 101800-30-1 0P	2025788	100MHz-18GHz	Apr. 17, 2018	Jul. 05, 2018~ Jul. 11, 2018	Apr. 16, 2019	Radiation (03CH02-KS)
Amplifier	Agilent	8449B	3008A02384	1-26.5GHz Gain 30dB	Oct. 12, 2017	Jul. 05, 2018~ Jul. 11, 2018	Oct. 11, 2018	Radiation (03CH02-KS)
Amplifier	MITEQ	TTA1840-35 -HG	1887435	18~40GHz	Oct. 12, 2017	Jul. 05, 2018~ Jul. 11, 2018	Oct. 11, 2018	Radiation (03CH02-KS)
AC Power Source	Chroma	61601	616010002473	N/A	NCR	Jul. 05, 2018~ Jul. 11, 2018	NCR	Radiation (03CH02-KS)
Turn Table	MF	MF7802	N/A	0~360 degree	NCR	Jul. 05, 2018~ Jul. 11, 2018	NCR	Radiation (03CH02-KS)
Antenna Mast	MF	MF7802	N/A	1 m~4 m	NCR	Jul. 05, 2018~ Jul. 11, 2018	NCR	Radiation (03CH02-KS)

NCR: No Calibration Required



6 Uncertainty of Evaluation

Uncertainty of Radiated Emission Measurement (30 MHz ~ 1000 MHz)

Measuring Uncertainty for a Level of Confidence of 95% ($U = 2Uc(y)$)	3.3dB
---	-------

Uncertainty of Radiated Emission Measurement (1 GHz ~ 40 GHz)

Measuring Uncertainty for a Level of Confidence of 95% ($U = 2Uc(y)$)	2.8dB
---	-------



Appendix A. Test Results of Conducted Test

Conducted Output Power(Average power)

LTE Band 4 Maximum Average Power [dBm]						
BW [MHz]	RB Size	RB Offset	Mod	Lowest	Middle	Highest
20	1	0	QPSK	22.93	23.06	23.27
20	1	49		22.81	22.98	23.05
20	1	99		22.91	22.99	22.83
20	50	0		21.91	22.09	22.20
20	50	24		21.89	22.08	22.13
20	50	50		21.90	22.05	21.98
20	100	0		21.91	22.07	22.11
20	1	0	16-QAM	22.35	22.48	22.67
20	1	49		22.20	22.44	22.45
20	1	99		22.36	22.41	22.19
20	50	0		21.02	21.24	21.34
20	50	24		21.01	21.22	21.27
20	50	50		21.03	21.16	21.10
20	100	0		20.99	21.18	21.20
20	1	0	64QAM	21.30	21.42	21.60
20	1	49		21.15	21.37	21.40
20	1	99		21.23	21.34	21.11
20	50	0		20.03	20.24	20.36
20	50	24		20.02	20.21	20.26
20	50	50		20.08	20.19	20.13
20	100	0		20.07	20.21	20.23
15	1	0	QPSK	22.95	23.09	23.26
15	1	37		22.76	23.03	22.97
15	1	74		22.92	23.08	22.86
15	36	0		21.86	22.08	22.18
15	36	20		21.89	22.11	22.11
15	36	39		21.85	22.11	21.96
15	75	0		21.87	22.05	22.04



15	1	0	16-QAM	22.32	22.53	22.63
15	1	37		22.11	22.45	22.36
15	1	74		22.26	22.45	22.20
15	36	0		21.01	21.22	21.31
15	36	20		20.99	21.23	21.21
15	36	39		21.00	21.21	21.08
15	75	0		20.96	21.23	21.16
15	1	0	64QAM	21.23	21.42	21.61
15	1	37		21.06	21.33	21.31
15	1	74		21.23	21.41	21.17
15	36	0		20.07	20.26	20.36
15	36	20		20.05	20.28	20.26
15	36	39		20.05	20.29	20.13
15	75	0		20.00	20.23	20.21



LTE Band 4 Maximum Average Power [dBm]						
BW [MHz]	RB Size	RB Offset	Mod	Lowest	Middle	Highest
10	1	0	QPSK	22.62	23.02	23.08
10	1	25		22.59	23.09	23.02
10	1	49		22.65	23.08	22.93
10	25	0		21.65	22.12	22.01
10	25	12		21.64	22.08	22.05
10	25	25		21.65	22.06	21.96
10	50	0		21.74	22.03	21.98
10	1	0	16-QAM	22.16	22.55	22.79
10	1	25		21.97	22.57	22.52
10	1	49		22.06	22.44	22.41
10	25	0		20.79	21.14	21.17
10	25	12		20.80	21.13	21.00
10	25	25		20.73	21.10	21.02
10	50	0		20.82	21.09	21.08
10	1	0	64QAM	21.22	21.44	21.42
10	1	25		21.02	21.39	21.37
10	1	49		21.15	21.38	21.16
10	25	0		19.96	20.27	20.25
10	25	12		19.95	20.29	20.20
10	25	25		19.92	20.25	20.11
10	50	0		19.94	20.27	20.20
5	1	0	QPSK	22.82	23.05	23.07
5	1	12		22.71	23.03	22.82
5	1	24		22.62	23.17	22.90
5	12	0		21.71	22.08	21.96
5	12	7		21.71	22.09	21.98
5	12	13		21.68	22.08	21.88
5	25	0		21.61	22.02	21.91
5	1	0	16-QAM	21.97	22.21	21.98
5	1	12		21.88	22.26	21.86
5	1	24		21.78	22.27	21.80
5	12	0		20.87	21.34	21.20
5	12	7		20.95	21.24	21.13



5	12	13	64QAM	20.85	21.23	21.02
5	25	0		20.88	21.18	21.01
5	1	0		21.15	21.45	21.37
5	1	12		21.05	21.43	21.21
5	1	24		21.00	21.45	21.21
5	12	0		20.02	20.33	20.19
5	12	7		20.00	20.36	20.18
5	12	13		19.98	20.31	20.14
5	25	0		19.91	20.24	20.08



LTE Band 4 Maximum Average Power [dBm]						
BW [MHz]	RB Size	RB Offset	Mod	Lowest	Middle	Highest
3	1	0	QPSK	22.71	22.95	22.76
3	1	8		22.74	22.97	22.89
3	1	14		22.61	22.95	22.69
3	8	0		21.64	22.07	21.86
3	8	4		21.63	22.03	21.95
3	8	7		21.62	22.02	21.95
3	15	0		21.68	22.03	21.95
3	1	0	16-QAM	21.76	22.21	22.12
3	1	8		21.84	22.37	22.20
3	1	14		21.69	22.26	22.10
3	8	0		20.77	21.20	21.11
3	8	4		20.77	21.17	21.09
3	8	7		20.75	21.27	21.00
3	15	0		20.71	21.11	21.08
3	1	0	64QAM	21.06	21.43	21.20
3	1	8		21.13	21.44	21.23
3	1	14		21.01	21.39	21.13
3	8	0		19.96	20.31	20.15
3	8	4		19.94	20.32	20.11
3	8	7		19.94	20.32	20.08
3	15	0		19.95	20.23	20.05
1.4	1	0	QPSK	22.61	22.78	22.69
1.4	1	3		22.69	22.82	22.91
1.4	1	5		22.49	22.85	22.63
1.4	3	0		22.66	22.99	22.75
1.4	3	1		22.71	23.00	22.79
1.4	3	3		22.53	23.00	22.84
1.4	6	0		21.54	22.01	21.76
1.4	1	0	16-QAM	21.86	22.18	21.78
1.4	1	3		21.89	22.34	21.82
1.4	1	5		21.79	22.13	21.76
1.4	3	0		21.68	22.08	21.92
1.4	3	1		21.76	22.12	21.96



1.4	3	3	64QAM	21.68	22.11	21.87
1.4	6	0		20.73	21.09	20.91
1.4	1	0		21.06	21.48	21.23
1.4	1	3		21.11	21.44	21.30
1.4	1	5		21.00	21.33	21.19
1.4	3	0		21.08	21.33	21.19
1.4	3	1		21.05	21.29	21.15
1.4	3	3		21.05	21.39	21.15
1.4	6	0		20.01	20.11	20.03



LTE Band 5 Maximum Average Power [dBm]						
BW [MHz]	RB Size	RB Offset	Mod	Lowest	Middle	Highest
10	1	0	QPSK	22.96	22.90	22.76
10	1	25		22.86	22.84	22.76
10	1	49		22.89	22.79	22.72
10	25	0		21.98	21.95	21.73
10	25	12		22.05	21.96	21.89
10	25	25		21.95	21.84	21.80
10	50	0		22.05	21.92	21.72
10	1	0	16-QAM	22.29	22.25	22.09
10	1	25		22.19	22.18	22.11
10	1	49		22.24	22.06	22.03
10	25	0		21.03	21.04	20.84
10	25	12		21.11	21.03	20.92
10	25	25		21.09	20.97	20.92
10	50	0		21.11	20.98	20.84
10	1	0	64QAM	21.15	21.18	21.02
10	1	25		21.09	21.10	20.99
10	1	49		21.11	21.00	20.93
10	25	0		19.96	19.99	19.80
10	25	12		20.05	19.99	19.89
10	25	25		20.01	19.95	19.87
10	50	0		20.05	19.95	19.82
5	1	0	QPSK	22.95	22.88	22.78
5	1	12		22.89	22.82	22.76
5	1	24		22.88	22.82	22.76
5	12	0		21.97	21.90	21.84
5	12	7		21.94	21.90	21.85
5	12	13		21.94	21.89	21.83
5	25	0		21.91	21.86	21.79
5	1	0	16-QAM	22.29	22.25	22.11
5	1	12		22.24	22.18	22.07
5	1	24		22.21	22.15	22.05
5	12	0		21.06	21.02	20.92
5	12	7		21.06	21.03	20.91



5	12	13	64QAM	21.05	20.99	20.90
5	25	0		21.04	20.99	20.89
5	1	0		21.13	21.06	20.99
5	1	12		21.10	21.02	20.98
5	1	24		21.09	21.00	20.93
5	12	0		19.99	20.00	19.93
5	12	7		20.04	20.04	19.96
5	12	13		19.96	19.98	19.95
5	25	0		19.94	19.95	19.90



LTE Band 5 Maximum Average Power [dBm]						
BW [MHz]	RB Size	RB Offset	Mod	Lowest	Middle	Highest
3	1	0	QPSK	22.92	22.85	22.77
3	1	8		22.95	22.94	22.84
3	1	14		22.90	22.83	22.76
3	8	0		21.99	21.89	21.80
3	8	4		21.97	21.94	21.82
3	8	7		21.95	21.86	21.81
3	15	0		21.97	21.91	21.82
3	1	0	16-QAM	22.28	22.20	22.07
3	1	8		22.34	22.32	22.17
3	1	14		22.23	22.14	22.05
3	8	0		21.13	21.02	20.94
3	8	4		21.10	21.07	20.98
3	8	7		21.09	21.00	20.92
3	15	0		21.08	21.00	20.91
3	1	0	64QAM	21.09	21.05	20.97
3	1	8		21.16	21.15	21.05
3	1	14		21.06	21.00	20.95
3	8	0		20.01	19.97	19.89
3	8	4		20.00	20.00	19.93
3	8	7		19.99	19.96	19.89
3	15	0		19.96	19.91	19.84
1.4	1	0	QPSK	22.84	22.75	22.68
1.4	1	3		22.92	22.81	22.75
1.4	1	5		22.81	22.73	22.63
1.4	3	0		22.88	22.80	22.72
1.4	3	1		22.92	22.83	22.75
1.4	3	3		22.91	22.81	22.75
1.4	6	0		21.90	21.80	21.71
1.4	1	0	16-QAM	22.17	22.09	21.97
1.4	1	3		22.29	22.14	22.05
1.4	1	5		22.15	22.06	21.97
1.4	3	0		21.97	21.92	21.78
1.4	3	1		22.00	21.92	21.78



1.4	3	3	64QAM	22.01	21.91	21.81
1.4	6	0		21.05	20.96	20.86
1.4	1	0		21.03	20.94	20.86
1.4	1	3		21.12	21.03	20.99
1.4	1	5		20.99	20.91	20.88
1.4	3	0		21.02	20.97	20.90
1.4	3	1		21.05	21.05	20.96
1.4	3	3		21.05	21.07	20.91
1.4	6	0		19.89	19.81	19.75



LTE Band 7 Maximum Average Power [dBm]						
BW [MHz]	RB Size	RB Offset	Mod	Lowest	Middle	Highest
20	1	0	QPSK	22.09	22.12	22.35
20	1	49		22.13	22.47	22.67
20	1	99		22.17	22.48	22.88
20	50	0		21.29	21.30	21.60
20	50	24		21.31	21.47	21.71
20	50	50		21.27	21.53	21.87
20	100	0		21.25	21.46	21.64
20	1	0	16-QAM	21.44	21.50	21.71
20	1	49		21.49	21.78	22.00
20	1	99		21.50	21.86	22.14
20	50	0		20.37	20.44	20.72
20	50	24		20.42	20.61	20.80
20	50	50		20.37	20.61	20.94
20	100	0		20.35	20.57	20.72
20	1	0	64QAM	20.52	20.59	20.62
20	1	49		20.54	20.76	20.89
20	1	99		20.51	20.76	21.08
20	50	0		19.50	19.53	19.71
20	50	24		19.53	19.58	19.80
20	50	50		19.52	19.67	19.93
20	100	0		19.51	19.58	19.76
15	1	0	QPSK	22.13	22.20	22.56
15	1	37		22.21	22.48	22.66
15	1	74		22.12	22.47	22.87
15	36	0		21.23	21.40	21.75
15	36	20		21.30	21.53	21.79
15	36	39		21.24	21.49	21.83
15	75	0		21.26	21.48	21.76
15	1	0	16-QAM	21.51	21.52	21.94
15	1	37		21.56	21.81	21.99
15	1	74		21.49	21.79	22.16
15	36	0		20.31	20.55	20.82
15	36	20		20.38	20.61	20.86



15	36	39	64QAM	20.33	20.63	20.89
15	75	0		20.34	20.55	20.83
15	1	0		20.55	20.57	20.84
15	1	37		20.58	20.73	20.92
15	1	74		20.56	20.68	21.11
15	36	0		19.53	19.56	19.83
15	36	20		19.54	19.62	19.93
15	36	39		19.54	19.66	19.92
15	75	0		19.51	19.55	19.84



LTE Band 7 Maximum Average Power [dBm]						
BW [MHz]	RB Size	RB Offset	Mod	Lowest	Middle	Highest
10	1	0	QPSK	22.13	22.27	22.64
10	1	25		22.16	22.44	22.71
10	1	49		22.10	22.39	22.86
10	25	0		21.24	21.40	21.76
10	25	12		21.31	21.48	21.80
10	25	25		21.22	21.50	21.84
10	50	0		21.29	21.48	21.88
10	1	0	16-QAM	21.46	21.57	21.91
10	1	25		21.49	21.74	22.01
10	1	49		21.48	21.69	22.11
10	25	0		20.31	20.48	20.84
10	25	12		20.40	20.56	20.87
10	25	25		20.31	20.57	20.89
10	50	0		20.39	20.57	20.92
10	1	0	64QAM	20.53	20.59	20.84
10	1	25		20.53	20.70	20.95
10	1	49		20.51	20.64	21.04
10	25	0		19.51	19.55	19.81
10	25	12		19.53	19.55	19.85
10	25	25		19.50	19.57	19.94
10	50	0		19.51	19.56	19.96
5	1	0	QPSK	22.14	22.30	22.70
5	1	12		22.20	22.45	22.82
5	1	24		22.16	22.43	22.85
5	12	0		21.31	21.41	21.79
5	12	7		21.33	21.48	21.88
5	12	13		21.27	21.46	21.90
5	25	0		21.25	21.43	21.84
5	1	0	16-QAM	21.47	21.60	22.01
5	1	12		21.59	21.78	22.11
5	1	24		21.46	21.81	22.12
5	12	0		20.38	20.52	20.87
5	12	7		20.40	20.56	20.94



5	12	13		20.36	20.55	20.97
5	25	0		20.34	20.51	20.88
5	1	0	64QAM	20.53	20.58	20.94
5	1	12		20.56	20.71	21.03
5	1	24		20.54	20.72	21.07
5	12	0		19.51	19.56	19.91
5	12	7		19.53	19.60	19.98
5	12	13		19.52	19.63	19.99
5	25	0		19.51	19.57	19.94



LTE Band 38 Maximum Average Power [dBm]						
BW [MHz]	RB Size	RB Offset	Mod	Lowest	Middle	Highest
20	1	0	QPSK	22.72	22.66	22.68
20	1	49		22.90	22.79	22.75
20	1	99		22.77	22.71	22.63
20	50	0		21.85	21.81	21.75
20	50	24		21.81	21.80	21.73
20	50	50		21.86	21.81	21.78
20	100	0		21.81	21.79	21.73
20	1	0	16-QAM	21.87	21.82	21.80
20	1	49		22.03	21.92	21.85
20	1	99		21.91	21.84	21.72
20	50	0		20.98	20.90	20.87
20	50	24		20.95	20.96	20.88
20	50	50		20.95	20.90	20.81
20	100	0		20.90	20.89	20.84
20	1	0	64QAM	20.64	20.56	20.57
20	1	49		20.78	20.69	20.58
20	1	99		20.68	20.59	20.52
20	50	0		19.97	19.87	19.84
20	50	24		19.95	19.92	19.87
20	50	50		19.95	19.90	19.83
20	100	0		19.87	19.88	19.83
15	1	0	QPSK	22.76	22.70	22.71
15	1	37		22.88	22.81	22.73
15	1	74		22.80	22.77	22.68
15	36	0		21.83	21.79	21.72
15	36	20		21.92	21.84	21.76
15	36	39		21.82	21.80	21.73
15	75	0		21.80	21.78	21.73
15	1	0	16-QAM	21.94	21.87	21.81
15	1	37		22.04	21.92	21.83
15	1	74		21.93	21.87	21.75
15	36	0		20.92	20.84	20.78
15	36	20		21.00	20.89	20.81



15	36	39	64QAM	20.89	20.85	20.78
15	75	0		20.89	20.89	20.80
15	1	0		20.68	20.61	20.58
15	1	37		20.74	20.67	20.56
15	1	74		20.70	20.63	20.50
15	36	0		19.95	19.88	19.80
15	36	20		20.03	19.91	19.84
15	36	39		19.91	19.90	19.79
15	75	0		19.91	19.90	19.81



LTE Band 38 Maximum Average Power [dBm]						
BW [MHz]	RB Size	RB Offset	Mod	Lowest	Middle	Highest
10	1	0	QPSK	22.77	22.72	22.69
10	1	25		22.85	22.82	22.70
10	1	49		22.89	22.76	22.65
10	25	0		21.82	21.77	21.74
10	25	12		21.90	21.82	21.71
10	25	25		21.87	21.77	21.69
10	50	0		21.85	21.82	21.72
10	1	0	16-QAM	21.90	21.88	21.82
10	1	25		21.93	21.92	21.81
10	1	49		21.98	21.86	21.74
10	25	0		20.95	20.89	20.82
10	25	12		21.01	20.93	20.87
10	25	25		20.99	20.90	20.82
10	50	0		20.98	20.91	20.85
10	1	0	64QAM	20.66	20.62	20.57
10	1	25		20.75	20.66	20.58
10	1	49		20.74	20.60	20.52
10	25	0		19.99	19.91	19.85
10	25	12		20.04	19.98	19.87
10	25	25		20.02	19.92	19.84
10	50	0		19.98	19.92	19.82
5	1	0	QPSK	22.78	22.75	22.70
5	1	12		22.81	22.78	22.70
5	1	24		22.78	22.73	22.64
5	12	0		21.84	21.79	21.70
5	12	7		21.90	21.82	21.74
5	12	13		21.88	21.81	21.73
5	25	0		21.83	21.76	21.70
5	1	0	16-QAM	21.90	21.86	21.77
5	1	12		21.94	21.89	21.79
5	1	24		21.96	21.89	21.78
5	12	0		20.88	20.83	20.74
5	12	7		20.93	20.88	20.81



5	12	13		20.90	20.87	20.78
5	25	0		20.95	20.90	20.80
5	1	0	64QAM	20.65	20.64	20.56
5	1	12		20.67	20.67	20.55
5	1	24		20.73	20.68	20.54
5	12	0		19.96	19.90	19.81
5	12	7		19.98	19.92	19.83
5	12	13		19.96	19.90	19.80
5	25	0		19.98	19.90	19.83



CA Power

CA_7C								
Combination 20MHz+20MHz (100RB+100RB)								
PCC Channel	SCC Channel	Modulation	PCC		SCC		Total RB Size	Measured Power (dBm)
			RB Size	RB offset	RB Size	RB offset		
20850	21048	QPSK	0	0	1	99	1	22.84
			1	0	0	0	1	22.65
			100	0	0	0	100	21.87
			100	0	100	0	200	20.92
			1	0	1	99	2	14.21
			1	0	1	0	2	18.17
			1	99	1	0	2	22.83
			100	0	1	99	101	20.38
		16QAM	0	0	1	99	1	22.31
			1	0	0	0	1	22.01
			100	0	0	0	100	20.94
			100	0	100	0	200	19.94
			1	0	1	99	2	13.75
			1	0	1	0	2	17.66
			1	99	1	0	2	22.17
			100	0	1	99	101	19.43
		64QAM	0	0	1	99	1	21.04
			1	0	0	0	1	20.52
			100	0	0	0	100	19.94
			100	0	100	0	200	19.93
			1	0	1	99	2	14.36
			1	0	1	0	2	17.54
			1	99	1	0	2	19.94
			100	0	1	99	101	19.45



21001	21199	QPSK	0	0	1	99	1	22.92
			1	0	0	0	1	22.62
			100	0	0	0	100	21.65
			100	0	100	0	200	20.75
			1	0	1	99	2	14.48
			1	0	1	0	2	18.06
			1	99	1	0	2	22.82
			100	0	1	99	101	20.37
		16QAM	0	0	1	99	1	22.25
			1	23	0	0	1	21.99
			100	0	0	0	100	20.87
			100	0	100	0	200	19.74
			1	0	1	99	2	13.65
			1	0	1	0	2	17.58
			1	99	1	0	2	21.98
			100	0	1	99	101	19.36
		64QAM	0	0	1	99	1	20.98
			1	0	0	0	1	21.39
			100	0	0	0	100	19.87
			100	0	100	0	200	19.84
			1	0	1	99	2	14.45
			1	0	1	0	2	17.65
			1	99	1	0	2	19.98
			100	0	1	99	101	19.55



21152	21350	QPSK	0	0	1	99	1	22.81
			1	0	0	0	1	22.45
			100	0	0	0	100	21.95
			100	0	100	0	200	20.99
			1	0	1	99	2	14.45
			1	0	1	0	2	18.62
			1	99	1	0	2	22.78
			100	0	1	99	101	20.28
		16QAM	0	0	1	99	1	22.26
			1	0	0	0	1	21.95
			100	0	0	0	100	20.92
			100	0	100	0	200	19.87
			1	0	1	99	2	13.78
			1	0	1	0	2	17.67
			1	99	1	0	2	21.98
			100	0	1	99	101	18.98
		64QAM	0	0	1	99	1	21.18
			1	0	0	0	1	20.65
			100	0	0	0	100	20.25
			100	0	100	0	200	19.98
			1	0	1	99	2	14.76
			1	0	1	0	2	17.74
			1	99	1	0	2	19.98
			100	0	1	99	101	19.36



CA_7C								
Combination 20MHz+15MHz (100RB+75RB)								
PCC Channel	SCC Channel	Modulation	PCC		SCC		Total RB Size	Measured Power (dBm)
			RB Size	RB offset	RB Size	RB offset		
20850	21021	QPSK	100	0	75	0	175	20.90
		QPSK	1	0	1	74	2	14.24
		QPSK	1	99	1	0	2	22.89
		16QAM	100	0	75	0	175	19.99
		16QAM	1	0	1	74	2	14.69
		16QAM	1	99	1	0	2	22.19
		64QAM	100	0	75	0	175	20.01
		64QAM	1	0	1	74	2	14.51
		64QAM	1	99	1	0	2	19.93
21026	21197	QPSK	100	0	75	0	175	20.98
		QPSK	1	0	1	74	2	14.24
		QPSK	1	99	1	0	2	23.16
		16QAM	100	0	75	0	175	20.05
		16QAM	1	0	1	74	2	14.67
		16QAM	1	99	1	0	2	22.37
		64QAM	100	0	75	0	175	20.06
		64QAM	1	0	1	74	2	14.33
		64QAM	1	99	1	0	2	20.18
21201	21372	QPSK	100	0	75	0	175	21.04
		QPSK	1	0	1	74	2	14.47
		QPSK	1	99	1	0	2	22.95
		16QAM	100	0	75	0	175	20.01
		16QAM	1	0	1	74	2	14.93
		16QAM	1	99	1	0	2	22.25
		64QAM	100	0	75	0	175	20.05
		64QAM	1	0	1	74	2	14.75
		64QAM	1	99	1	0	2	19.97



Combination 15MHz+20MHz (75RB+100RB)								
PCC Channel	SCC Channel	Modulation	PCC		SCC		Total RB Size	Measured Power (dBm)
			RB Size	RB offset	RB Size	RB offset		
20828	20999	QPSK	75	0	100	0	175	21.06
		QPSK	1	0	1	99	2	14.45
		QPSK	1	74	1	0	2	22.99
		16QAM	75	0	100	0	175	19.90
		16QAM	1	0	1	99	2	14.98
		16QAM	1	74	1	0	2	22.39
		64QAM	75	0	100	0	175	20.15
		64QAM	1	0	1	99	2	14.68
		64QAM	1	74	1	0	2	20.23
21003	21174	QPSK	75	0	100	0	175	21.06
		QPSK	1	0	1	99	2	14.54
		QPSK	1	74	1	0	2	23.20
		16QAM	75	0	100	0	175	19.60
		16QAM	1	0	1	99	2	14.49
		16QAM	1	74	1	0	2	22.25
		64QAM	75	0	100	0	175	20.15
		64QAM	1	0	1	99	2	14.55
		64QAM	1	74	1	0	2	20.29
21179	21350	QPSK	75	0	100	0	175	21.15
		QPSK	1	0	1	99	2	14.73
		QPSK	1	74	1	0	2	22.69
		16QAM	75	0	100	0	175	20.15
		16QAM	1	0	1	99	2	14.86
		16QAM	1	74	1	0	2	22.42
		64QAM	75	0	100	0	175	19.95
		64QAM	1	0	1	99	2	14.89
		64QAM	1	74	1	0	2	19.99



Combination 20MHz+10MHz (100RB+50RB)								
PCC	SCC	Modulation	PCC		SCC		Total RB Size	Measured Power (dBm)
Channel	Channel		RB Size	RB offset	RB Size	RB offset		
20850	20994	QPSK	100	0	50	0	150	20.79
		QPSK	1	0	1	49	2	14.29
		QPSK	1	99	1	0	2	23.06
		16QAM	100	0	50	0	150	19.79
		16QAM	1	0	1	49	2	14.58
		16QAM	1	99	1	0	2	22.14
		64QAM	100	0	50	0	150	19.89
		64QAM	1	0	1	49	2	14.76
		64QAM	1	99	1	0	2	19.88
21051	21195	QPSK	100	0	50	0	150	21.06
		QPSK	1	0	1	49	2	14.36
		QPSK	1	99	1	0	2	23.02
		16QAM	100	0	50	0	150	19.99
		16QAM	1	0	1	49	2	14.76
		16QAM	1	99	1	0	2	22.45
		64QAM	100	0	50	0	150	19.78
		64QAM	1	0	1	49	2	14.55
		64QAM	1	99	1	0	2	20.25
21251	21395	QPSK	100	0	50	0	150	21.36
		QPSK	1	0	1	49	2	14.76
		QPSK	1	99	1	0	2	22.78
		16QAM	100	0	50	0	150	20.15
		16QAM	1	0	1	49	2	14.36
		16QAM	1	99	1	0	2	22.46
		64QAM	100	0	50	0	150	20.25
		64QAM	1	0	1	49	2	14.78
		64QAM	1	99	1	0	2	20.36



Combination 10MHz+20MHz (50RB+100RB)								
PCC	SCC	Modulation	PCC		SCC		Total RB Size	Measured Power (dBm)
Channel	Channel		RB Size	RB offset	RB Size	RB offset		
20805	20949	QPSK	50	0	100	0	150	20.79
		QPSK	1	0	1	99	2	14.75
		QPSK	1	49	1	0	2	22.79
		16QAM	50	0	100	0	150	19.95
		16QAM	1	0	1	99	2	14.77
		16QAM	1	49	1	0	2	22.46
		64QAM	50	0	100	0	150	20.18
		64QAM	1	0	1	99	2	14.75
		64QAM	1	49	1	0	2	20.26
21006	21150	QPSK	50	0	100	0	150	21.15
		QPSK	1	0	1	99	2	14.51
		QPSK	1	49	1	0	2	23.02
		16QAM	50	0	100	0	150	19.99
		16QAM	1	0	1	99	2	14.74
		16QAM	1	49	1	0	2	22.45
		64QAM	50	0	100	0	150	20.36
		64QAM	1	0	1	99	2	14.55
		64QAM	1	49	1	0	2	19.88
21206	21350	QPSK	50	0	100	0	150	21.18
		QPSK	1	0	1	99	2	14.76
		QPSK	1	49	1	0	2	22.78
		16QAM	50	0	100	0	150	20.12
		16QAM	1	0	1	99	2	14.59
		16QAM	1	49	1	0	2	22.36
		64QAM	50	0	100	0	150	20.15
		64QAM	1	0	1	99	2	14.77
		64QAM	1	49	1	0	2	20.09



Combination 15MHz+15MHz (75RB+75RB)								
PCC	SCC	Modulation	PCC		SCC		Total RB Size	Measured Power (dBm)
Channel	Channel		RB Size	RB offset	RB Size	RB offset		
20825	20975	QPSK	75	0	75	0	150	20.95
		QPSK	1	0	1	74	2	14.45
		QPSK	1	74	1	0	2	22.74
		16QAM	75	0	75	0	150	20.06
		16QAM	1	0	1	74	2	14.78
		16QAM	1	74	1	0	2	22.02
		64QAM	75	0	75	0	150	19.88
		64QAM	1	0	1	74	2	14.69
		64QAM	1	74	1	0	2	19.68
21025	21175	QPSK	75	0	75	0	150	20.92
		QPSK	1	0	1	74	2	14.78
		QPSK	1	74	1	0	2	23.05
		16QAM	75	0	75	0	150	20.25
		16QAM	1	0	1	74	2	14.68
		16QAM	1	74	1	0	2	21.96
		64QAM	75	0	75	0	150	20.17
		64QAM	1	0	1	74	2	14.51
		64QAM	1	74	1	0	2	19.88
21225	21375	QPSK	75	0	75	0	150	21.15
		QPSK	1	0	1	74	2	14.55
		QPSK	1	74	1	0	2	22.77
		16QAM	75	0	75	0	150	19.87
		16QAM	1	0	1	74	2	14.66
		16QAM	1	74	1	0	2	21.96
		64QAM	75	0	75	0	150	19.99
		64QAM	1	0	1	74	2	14.49
		64QAM	1	74	1	0	2	20.10



Combination 15MHz+10MHz (75RB+50RB)								
PCC	SCC	Modulation	PCC		SCC		Total RB Size	Measured Power (dBm)
Channel	Channel		RB Size	RB offset	RB Size	RB offset		
20825	20945	QPSK	75	0	50	0	125	20.96
		QPSK	1	0	1	49	2	14.54
		QPSK	1	74	1	0	2	22.78
		16QAM	75	0	50	0	125	19.68
		16QAM	1	0	1	49	2	14.79
		16QAM	1	74	1	0	2	22.08
		64QAM	75	0	50	0	125	19.95
		64QAM	1	0	1	49	2	14.45
		64QAM	1	74	1	0	2	19.77
21051	21171	QPSK	75	0	50	0	125	20.78
		QPSK	1	0	1	49	2	14.06
		QPSK	1	74	1	0	2	22.82
		16QAM	75	0	50	0	125	19.65
		16QAM	1	0	1	49	2	14.36
		16QAM	1	74	1	0	2	22.26
		64QAM	75	0	50	0	125	19.95
		64QAM	1	0	1	49	2	14.51
		64QAM	1	74	1	0	2	19.89
21277	21397	QPSK	75	0	50	0	125	20.88
		QPSK	1	0	1	49	2	14.79
		QPSK	1	74	1	0	2	22.78
		16QAM	75	0	50	0	125	20.01
		16QAM	1	0	1	49	2	14.78
		16QAM	1	74	1	0	2	22.12
		64QAM	75	0	50	0	125	19.95
		64QAM	1	0	1	49	2	14.60
		64QAM	1	74	1	0	2	19.69



CA_38C								
Combination 20MHz+20MHz (100RB+100RB)								
PCC Channel	SCC Channel	Modulation	PCC		SCC		Total RB Size	Measured Power (dBm)
			RB Size	RB offset	RB Size	RB offset		
37850	38048	QPSK	0	0	1	99	1	22.99
			1	0	0	0	1	22.80
			100	0	0	0	100	21.89
			100	0	100	0	200	20.90
			1	0	1	99	2	14.36
			1	0	1	0	2	18.39
			1	99	1	0	2	22.75
			100	0	1	99	101	20.38
		16QAM	0	0	1	99	1	22.33
			1	0	0	0	1	22.35
			100	0	0	0	100	20.98
			100	0	100	0	200	19.97
			1	0	1	99	2	14.80
			1	0	1	0	2	18.84
			1	99	1	0	2	22.34
			100	0	1	99	101	19.49
		64QAM	0	0	1	99	1	20.95
			1	0	0	0	1	21.06
			100	0	0	0	100	19.99
			100	0	100	0	200	20.02
			1	0	1	99	2	14.53
			1	0	1	0	2	18.55
			1	99	1	0	2	20.06
			100	0	1	99	101	19.46



37901	38099	QPSK	0	0	1	99	1	22.87
			1	0	0	0	1	22.60
			100	0	0	0	100	21.84
			100	0	100	0	200	20.76
			1	0	1	99	2	14.55
			1	0	1	0	2	18.62
			1	99	1	0	2	22.82
			100	0	1	99	101	20.55
		16QAM	0	0	1	99	1	22.13
			1	0	0	0	1	21.96
			100	0	0	0	100	21.45
			100	0	100	0	200	20.22
			1	0	1	99	2	14.79
			1	0	1	0	2	18.04
			1	99	1	0	2	21.95
			100	0	1	99	101	19.56
		64QAM	0	0	1	99	1	20.74
			1	0	0	0	1	20.67
			100	0	0	0	100	20.26
			100	0	100	0	200	19.99
			1	0	1	99	2	14.49
			1	0	1	0	2	18.55
			1	99	1	0	2	20.36
			100	0	1	99	101	19.46



37952	38150	QPSK	0	0	1	99	1	22.82
			1	0	0	0	1	22.68
			100	0	0	0	100	21.87
			100	0	100	0	200	21.09
			1	0	1	99	2	14.55
			1	0	1	0	2	18.74
			1	99	1	0	2	22.63
			100	0	1	99	101	20.51
		16QAM	0	0	1	99	1	22.26
			1	0	0	0	1	22.18
			100	0	0	0	100	20.87
			100	0	100	0	200	19.99
			1	0	1	99	2	14.10
			1	0	1	0	2	18.02
			1	99	1	0	2	22.44
			100	0	1	99	101	19.55
		64QAM	0	0	1	99	1	21.06
			1	0	0	0	1	20.65
			100	0	0	0	100	20.36
			100	0	100	0	200	19.95
			1	0	1	99	2	14.76
			1	0	1	0	2	18.77
			1	99	1	0	2	19.92
			100	0	1	99	101	19.68



CA_38C								
Combination 15MHz+15MHz (75RB+75RB)								
PCC	SCC	Modulation	PCC		SCC		Total RB Size	Measured Power (dBm)
Channel	Channel		RB Size	RB offset	RB Size	RB offset		
37825	37975	QPSK	75	0	75	0	150	20.86
		QPSK	1	0	1	74	2	14.40
		QPSK	1	74	1	0	2	22.96
		16QAM	75	0	75	0	150	19.97
		16QAM	1	0	1	74	2	14.85
		16QAM	1	74	1	0	2	22.33
		64QAM	75	0	75	0	150	19.96
		64QAM	1	0	1	74	2	14.56
		64QAM	1	74	1	0	2	20.03
37925	38075	QPSK	75	0	75	0	150	20.94
		QPSK	1	0	1	74	2	14.46
		QPSK	1	74	1	0	2	23.05
		16QAM	75	0	75	0	150	20.03
		16QAM	1	0	1	74	2	14.91
		16QAM	1	74	1	0	2	22.36
		64QAM	75	0	75	0	150	20.03
		64QAM	1	0	1	74	2	14.59
		64QAM	1	74	1	0	2	20.08
38025	38175	QPSK	75	0	75	0	150	20.98
		QPSK	1	0	1	74	2	14.43
		QPSK	1	74	1	0	2	23.08
		16QAM	75	0	75	0	150	20.08
		16QAM	1	0	1	74	2	14.88
		16QAM	1	74	1	0	2	22.35
		64QAM	75	0	75	0	150	20.06
		64QAM	1	0	1	74	2	14.57
		64QAM	1	74	1	0	2	20.07



ERP/EIRP

LTE Band 4 (GT - LC = -3.80 dB) QPSK									
Bandwidth	1.4M			3M			5M		
Channel	19957	20175	20393	19965	20175	20385	19975	20175	20375
	(Low)	(Mid)	(High)	(Low)	(Mid)	(High)	(Low)	(Mid)	(High)
Frequency	1710.7	1732.5	1754.3	1711.5	1732.5	1753.5	1712.5	1732.5	1752.5
(MHz)									
Conducted Power (dBm)	22.71	23.00	22.79	22.74	22.97	22.89	22.62	23.17	22.90
Conducted Power (Watts)	0.1866	0.1995	0.1901	0.1879	0.1982	0.1945	0.1828	0.2075	0.1950
EIRP(dBm)	18.91	19.20	18.99	18.94	19.17	19.09	18.82	19.37	19.10
EIRP(Watts)	0.0778	0.0832	0.0793	0.0783	0.0826	0.0811	0.0762	0.0865	0.0813

LTE Band 4 (GT - LC = -3.80 dB) QPSK									
Bandwidth	10M			15M			20M		
Channel	20000	20175	20350	20025	20175	20325	20050	20175	20300
	(Low)	(Mid)	(High)	(Low)	(Mid)	(High)	(Low)	(Mid)	(High)
Frequency	1715	1732.5	1750	1717.5	1732.5	1747.5	1720	1732.5	1745
(MHz)									
Conducted Power (dBm)	22.59	23.09	23.02	22.95	23.09	23.26	22.93	23.06	23.27
Conducted Power (Watts)	0.1816	0.2037	0.2004	0.1972	0.2037	0.2118	0.1963	0.2023	0.2123
EIRP(dBm)	18.79	19.29	19.22	19.15	19.29	19.46	19.13	19.26	19.47
EIRP(Watts)	0.0757	0.0849	0.0836	0.0822	0.0849	0.0883	0.0818	0.0843	0.0885



LTE Band 4 (GT - LC = -3.80 dB) 16QAM									
Bandwidth	1.4M			3M			5M		
Channel	19957	20175	20393	19965	20175	20385	19975	20175	20375
	(Low)	(Mid)	(High)	(Low)	(Mid)	(High)	(Low)	(Mid)	(High)
Frequency (MHz)	1710.7	1732.5	1754.3	1711.5	1732.5	1753.5	1712.5	1732.5	1752.5
Conducted Power (dBm)	21.89	22.34	21.82	21.84	22.37	22.20	21.78	22.27	21.80
Conducted Power (Watts)	0.1545	0.1714	0.1521	0.1528	0.1726	0.1660	0.1507	0.1687	0.1514
EIRP(dBm)	18.09	18.54	18.02	18.04	18.57	18.40	17.98	18.47	18.00
EIRP(Watts)	0.0644	0.0714	0.0634	0.0637	0.0719	0.0692	0.0628	0.0703	0.0631

LTE Band 4 (GT - LC = -3.80 dB) 16QAM									
Bandwidth	10M			15M			20M		
Channel	20000	20175	20350	20025	20175	20325	20050	20175	20300
	(Low)	(Mid)	(High)	(Low)	(Mid)	(High)	(Low)	(Mid)	(High)
Frequency (MHz)	1715	1732.5	1750	1717.5	1732.5	1747.5	1720	1732.5	1745
Conducted Power (dBm)	22.16	22.55	22.79	22.32	22.53	22.63	22.35	22.48	22.67
Conducted Power (Watts)	0.1644	0.1799	0.1901	0.1706	0.1791	0.1832	0.1718	0.1770	0.1849
EIRP(dBm)	18.36	18.75	18.99	18.52	18.73	18.83	18.55	18.68	18.87
EIRP(Watts)	0.0685	0.0750	0.0793	0.0711	0.0746	0.0764	0.0716	0.0738	0.0771



LTE Band 4 (G _T - L _C = -3.80 dB) 64QAM									
Bandwidth	1.4M			3M			5M		
Channel	19957	20175	20393	19965	20175	20385	19975	20175	20375
	(Low)	(Mid)	(High)	(Low)	(Mid)	(High)	(Low)	(Mid)	(High)
Frequency (MHz)	1710.7	1732.5	1754.3	1711.5	1732.5	1753.5	1712.5	1732.5	1752.5
Conducted Power (dBm)	21.06	21.48	21.23	21.73	22.11	22.47	21.90	22.36	22.15
Conducted Power (Watts)	0.1276	0.1406	0.1327	0.1489	0.1626	0.1766	0.1549	0.1722	0.1641
EIRP(dBm)	17.26	17.68	17.43	17.93	18.31	18.67	18.10	18.56	18.35
EIRP(Watts)	0.0532	0.0586	0.0553	0.0621	0.0678	0.0736	0.0646	0.0718	0.0684

LTE Band 4 (G _T - L _C = -3.80 dB) 64QAM									
Bandwidth	10M			15M			20M		
Channel	20000	20175	20350	20025	20175	20325	20050	20175	20300
	(Low)	(Mid)	(High)	(Low)	(Mid)	(High)	(Low)	(Mid)	(High)
Frequency (MHz)	1715	1732.5	1750	1717.5	1732.5	1747.5	1720	1732.5	1745
Conducted Power (dBm)	21.99	22.37	22.64	21.23	21.42	21.61	21.30	21.42	21.60
Conducted Power (Watts)	0.1581	0.1726	0.1837	0.1327	0.1387	0.1449	0.1349	0.1387	0.1445
EIRP(dBm)	18.19	18.57	18.84	17.43	17.62	17.81	17.50	17.62	17.80
EIRP(Watts)	0.0659	0.0719	0.0766	0.0553	0.0578	0.0604	0.0562	0.0578	0.0603



LTE Band 5 (GT - LC = -6.20 dB) QPSK									
Bandwidth	1.4M			3M			5M		
Channel	20407	20525	20643	20415	20525	20635	20425	20525	20625
	(Low)	(Mid)	(High)	(Low)	(Mid)	(High)	(Low)	(Mid)	(High)
Frequency (MHz)	824.7	836.5	848.3	825.5	836.5	847.5	826.5	836.5	846.5
Conducted Power (dBm)	22.92	22.81	22.75	22.95	22.94	22.84	22.95	22.88	22.78
Conducted Power (Watts)	0.1959	0.1910	0.1884	0.1972	0.1968	0.1923	0.1972	0.1941	0.1897
ERP(dBm)	14.57	14.46	14.40	14.60	14.59	14.49	14.60	14.53	14.43
ERP(Watts)	0.0286	0.0279	0.0275	0.0288	0.0288	0.0281	0.0288	0.0284	0.0277

LTE Band 5 (GT - LC = -6.20 dB) QPSK			
Bandwidth	10M		
Channel	20450	20525	20600
	(Low)	(Mid)	(High)
Frequency (MHz)	829	836.5	844
Conducted Power (dBm)	22.96	22.90	22.76
Conducted Power (Watts)	0.1977	0.1950	0.1888
ERP(dBm)	14.61	14.55	14.41
ERP(Watts)	0.0289	0.0285	0.0276



LTE Band 5 (GT - LC = -6.20 dB) 16QAM									
Bandwidth	1.4M			3M			5M		
Channel	20407	20525	20643	20415	20525	20635	20425	20525	20625
	(Low)	(Mid)	(High)	(Low)	(Mid)	(High)	(Low)	(Mid)	(High)
Frequency (MHz)	824.7	836.5	848.3	825.5	836.5	847.5	826.5	836.5	846.5
Conducted Power (dBm)	22.29	22.14	22.05	22.34	22.32	22.17	22.29	22.25	22.11
Conducted Power (Watts)	0.1694	0.1637	0.1603	0.1714	0.1706	0.1648	0.1694	0.1679	0.1626
ERP(dBm)	13.94	13.79	13.70	13.99	13.97	13.82	13.94	13.90	13.76
ERP(Watts)	0.0248	0.0239	0.0234	0.0251	0.0249	0.0241	0.0248	0.0245	0.0238

LTE Band 5 (GT - LC = -6.20 dB) 16QAM			
Bandwidth	10M		
Channel	20450	20525	20600
	(Low)	(Mid)	(High)
Frequency (MHz)	829	836.5	844
Conducted Power (dBm)	22.29	22.25	22.09
Conducted Power (Watts)	0.1694	0.1679	0.1618
ERP(dBm)	13.94	13.90	13.74
ERP(Watts)	0.0248	0.0245	0.0237



LTE Band 5 ($G_T - L_C = -6.20$ dB) 64QAM									
Bandwidth	1.4M			3M			5M		
Channel	20407	20525	20643	20415	20525	20635	20425	20525	20625
	(Low)	(Mid)	(High)	(Low)	(Mid)	(High)	(Low)	(Mid)	(High)
Frequency	824.7	836.5	848.3	825.5	836.5	847.5	826.5	836.5	846.5
(MHz)									
Conducted Power (dBm)	22.14	22.01	21.90	22.25	22.17	22.07	22.17	22.16	22.01
Conducted Power (Watts)	0.1637	0.1589	0.1549	0.1679	0.1648	0.1611	0.1648	0.1644	0.1589
ERP(dBm)	13.79	13.66	13.55	13.90	13.82	13.72	13.82	13.81	13.66
ERP(Watts)	0.0239	0.0232	0.0226	0.0245	0.0241	0.0236	0.0241	0.0240	0.0232

LTE Band 5 ($G_T - L_C = -6.20$ dB) 64QAM			
Bandwidth	10M		
Channel	20450	20525	20600
	(Low)	(Mid)	(High)
Frequency	829	836.5	844
(MHz)			
Conducted Power (dBm)	22.19	22.16	21.98
Conducted Power (Watts)	0.1656	0.1644	0.1578
ERP(dBm)	13.84	13.81	13.63
ERP(Watts)	0.0242	0.0240	0.0231



LTE Band 7 (GT - LC = -2.90 dB) QPSK			
Bandwidth	5M		
Channel	20775	21100	21425
	(Low)	(Mid)	(High)
Frequency	2502.5	2535	2567.5
(MHz)			
Conducted Power (dBm)	22.16	22.43	22.85
Conducted Power (Watts)	0.1644	0.1750	0.1928
EIRP(dBm)	19.26	19.53	19.95
EIRP(Watts)	0.0843	0.0897	0.0989

LTE Band 7 (GT - LC = -2.90 dB) QPSK									
Bandwidth	10M			15M			20M		
Channel	20800	21100	21400	20825	21100	21375	20850	21100	21350
	(Low)	(Mid)	(High)	(Low)	(Mid)	(High)	(Low)	(Mid)	(High)
Frequency	2505	2535	2565	2507.5	2535	2562.5	2510	2535	2560
(MHz)									
Conducted Power (dBm)	22.10	22.39	22.86	22.12	22.47	22.87	22.13	22.48	22.88
Conducted Power (Watts)	0.1622	0.1734	0.1932	0.1629	0.1766	0.1936	0.1633	0.1770	0.1941
EIRP(dBm)	19.20	19.49	19.96	19.22	19.57	19.97	19.23	19.58	19.98
EIRP(Watts)	0.0832	0.0889	0.0991	0.0836	0.0906	0.0993	0.0838	0.0908	0.0995



LTE Band 7 (GT - LC = -2.90 dB) 16QAM			
Bandwidth	5M		
Channel	20775	21100	21425
	(Low)	(Mid)	(High)
Frequency (MHz)	2502.5	2535	2567.5
	Conducted Power (dBm)	21.46	21.81
Conducted Power (Watts)	0.1400	0.1517	0.1629
EIRP(dBm)	18.56	18.91	19.22
EIRP(Watts)	0.0718	0.0778	0.0836

LTE Band 7 (GT - LC = -2.90 dB) 16QAM									
Bandwidth	10M			15M			20M		
Channel	20800	21100	21400	20825	21100	21375	20850	21100	21350
	(Low)	(Mid)	(High)	(Low)	(Mid)	(High)	(Low)	(Mid)	(High)
Frequency (MHz)	2505	2535	2565	2507.5	2535	2562.5	2510	2535	2560
	Conducted Power (dBm)	21.48	21.69	22.11	21.49	21.79	22.16	21.50	21.86
Conducted Power (Watts)	0.1406	0.1476	0.1626	0.1409	0.1510	0.1644	0.1413	0.1535	0.1637
EIRP(dBm)	18.58	18.79	19.21	18.59	18.89	19.26	18.60	18.96	19.24
EIRP(Watts)	0.0721	0.0757	0.0834	0.0723	0.0774	0.0843	0.0724	0.0787	0.0839



LTE Band 7 ($G_T - L_C = -2.90$ dB) 64QAM			
Bandwidth	5M		
Channel	20775	21100	21425
	(Low)	(Mid)	(High)
Frequency	2502.5	2535	2567.5
(MHz)			
Conducted Power (dBm)	20.54	20.72	21.07
Conducted Power (Watts)	0.1132	0.1180	0.1279
EIRP(dBm)	17.64	17.82	18.17
EIRP(Watts)	0.0581	0.0605	0.0656

LTE Band 7 ($G_T - L_C = -2.90$ dB) 64QAM									
Bandwidth	10M			15M			20M		
Channel	20800	21100	21400	20825	21100	21375	20850	21100	21350
	(Low)	(Mid)	(High)	(Low)	(Mid)	(High)	(Low)	(Mid)	(High)
Frequency	2505	2535	2565	2507.5	2535	2562.5	2510	2535	2560
(MHz)									
Conducted Power (dBm)	20.51	20.64	21.04	20.56	20.68	21.11	20.51	20.76	21.08
Conducted Power (Watts)	0.1125	0.1159	0.1271	0.1138	0.1169	0.1291	0.1125	0.1191	0.1282
EIRP(dBm)	17.61	17.74	18.14	17.66	17.78	18.21	17.61	17.86	18.18
EIRP(Watts)	0.0577	0.0594	0.0652	0.0583	0.0600	0.0662	0.0577	0.0611	0.0658



LTE Band 38 (GT - LC = -3.60 dB) QPSK			
Bandwidth	5M		
Channel	37775	38000	38225
	(Low)	(Mid)	(High)
Frequency	2572.5	2595	2617.5
(MHz)			
Conducted Power (dBm)	22.81	22.78	22.70
Conducted Power (Watts)	0.1910	0.1897	0.1862
EIRP(dBm)	19.21	19.18	19.10
EIRP(Watts)	0.0834	0.0828	0.0813

LTE Band 38 (GT - LC = -3.60 dB) QPSK									
Bandwidth	10M			15M			20M		
Channel	37800	38000	38200	37825	38000	38175	37850	38000	38150
	(Low)	(Mid)	(High)	(Low)	(Mid)	(High)	(Low)	(Mid)	(Mid)
Frequency	2575	2595	2615	2577.5	2595	2612.5	2580	2595	2610
(MHz)									
Conducted Power (dBm)	22.89	22.76	22.65	22.88	22.81	22.73	22.90	22.79	22.75
Conducted Power (Watts)	0.1945	0.1888	0.1841	0.1941	0.1910	0.1875	0.1950	0.1901	0.1884
EIRP(dBm)	19.29	19.16	19.05	19.28	19.21	19.13	19.30	19.19	19.15
EIRP(Watts)	0.0849	0.0824	0.0804	0.0847	0.0834	0.0818	0.0851	0.0830	0.0822



LTE Band 38 (GT - LC = -3.60 dB) 16QAM			
Bandwidth	5M		
Channel	37775	38000	38225
	(Low)	(Mid)	(High)
Frequency	2572.5	2595	2617.5
(MHz)			
Conducted Power (dBm)	21.96	21.89	21.78
Conducted Power (Watts)	0.1570	0.1545	0.1507
EIRP(dBm)	18.36	18.29	18.18
EIRP(Watts)	0.0685	0.0675	0.0658

LTE Band 38 (GT - LC = -3.60 dB) 16QAM									
Bandwidth	10M			15M			20M		
Channel	37800	38000	38200	37825	38000	38175	37850	38000	38150
	(Low)	(Mid)	(High)	(Low)	(Mid)	(High)	(Low)	(Mid)	(Mid)
Frequency	2575	2595	2615	2577.5	2595	2612.5	2580	2595	2610
(MHz)									
Conducted Power (dBm)	21.98	21.86	21.74	22.04	21.92	21.83	22.03	21.92	21.85
Conducted Power (Watts)	0.1578	0.1535	0.1493	0.1600	0.1556	0.1524	0.1596	0.1556	0.1531
EIRP(dBm)	18.38	18.26	18.14	18.44	18.32	18.23	18.43	18.32	18.25
EIRP(Watts)	0.0689	0.0670	0.0652	0.0698	0.0679	0.0665	0.0697	0.0679	0.0668



LTE Band 38 (G _T - L _C = -3.60 dB) 64QAM			
Bandwidth	5M		
Channel	37775	38000	38225
	(Low)	(Mid)	(High)
Frequency	2572.5	2595	2617.5
(MHz)			
Conducted Power (dBm)	20.73	20.68	20.54
Conducted Power (Watts)	0.1183	0.1169	0.1132
EIRP(dBm)	17.13	17.08	16.94
EIRP(Watts)	0.0516	0.0511	0.0494

LTE Band 38 (G _T - L _C = -3.60 dB) 64QAM									
Bandwidth	10M			15M			20M		
Channel	37800	38000	38200	37825	38000	38175	37850	38000	38150
	(Low)	(Mid)	(High)	(Low)	(Mid)	(High)	(Low)	(Mid)	(Mid)
Frequency	2575	2595	2615	2577.5	2595	2612.5	2580	2595	2610
(MHz)									
Conducted Power (dBm)	20.75	20.66	20.58	20.74	20.67	20.56	20.78	20.69	20.58
Conducted Power (Watts)	0.1189	0.1164	0.1143	0.1186	0.1167	0.1138	0.1197	0.1172	0.1143
EIRP(dBm)	17.15	17.06	16.98	17.14	17.07	16.96	17.18	17.09	16.98
EIRP(Watts)	0.0519	0.0508	0.0499	0.0518	0.0509	0.0497	0.0522	0.0512	0.0499



CA EIRP

LTE Band 7 CA (GT - LC = -2.90 dB) QPSK									
Bandwidth	15M + 15M			10M + 20M			20M+10M		
Channel PCC	20825	21025	21225	20805	21006	21206	20850	21051	21251
	(Low)	(Mid)	(High)	(Low)	(Mid)	(High)	(Low)	(Mid)	(High)
Channel SCC	20975	21175	21375	20949	21150	21350	20994	21195	21395
	(Low)	(Mid)	(High)	(Low)	(Mid)	(High)	(Low)	(Mid)	(High)
Conducted Power (dBm)	23.24	23.55	23.27	23.29	23.52	23.28	23.56	23.52	23.28
Conducted Power (Watts)	0.2109	0.2265	0.2123	0.2133	0.2249	0.2128	0.2270	0.2249	0.2128
EIRP(dBm)	20.34	20.65	20.37	20.39	20.62	20.38	20.66	20.62	20.38
EIRP(Watts)	0.1081	0.1161	0.1089	0.1094	0.1153	0.1091	0.1164	0.1153	0.1091

LTE Band 7 CA (GT - LC = -2.90 dB) QPSK									
Bandwidth	15M+20M			20M+15M			20M + 20M		
Channel PCC	20828	21003	21179	20850	21026	21201	20850	21001	21152
	(Low)	(Mid)	(High)	(Low)	(Mid)	(High)	(Low)	(Mid)	(High)
Channel SCC	20999	21174	21350	21021	21197	21372	21048	21199	21350
	(Low)	(Mid)	(High)	(Low)	(Mid)	(High)	(Low)	(Mid)	(High)
Conducted Power (dBm)	23.49	23.70	23.19	23.39	23.66	23.45	23.34	23.42	23.28
Conducted Power (Watts)	0.2234	0.2344	0.2084	0.2183	0.2323	0.2213	0.2158	0.2198	0.2128
EIRP(dBm)	20.59	20.80	20.29	20.49	20.76	20.55	20.44	20.52	20.38
EIRP(Watts)	0.1146	0.1202	0.1069	0.1119	0.1191	0.1135	0.1107	0.1127	0.1091



LTE Band 7 CA (GT - LC = -2.90 dB) 16QAM									
Bandwidth	15M + 15M			10M + 20M			20M+10M		
Channel PCC	20825	21025	21225	20805	21006	21206	20850	21051	21251
	(Low)	(Mid)	(High)	(Low)	(Mid)	(High)	(Low)	(Mid)	(High)
Channel SCC	20975	21175	21375	20949	21150	21350	20994	21195	21395
	(Low)	(Mid)	(High)	(Low)	(Mid)	(High)	(Low)	(Mid)	(High)
Conducted Power (dBm)	22.52	22.46	22.46	22.96	22.95	22.86	22.64	22.95	22.96
Conducted Power (Watts)	0.1786	0.1762	0.1762	0.1977	0.1972	0.1932	0.1837	0.1972	0.1977
EIRP(dBm)	19.62	19.56	19.56	20.06	20.05	19.96	19.74	20.05	20.06
EIRP(Watts)	0.0916	0.0904	0.0904	0.1014	0.1012	0.0991	0.0942	0.1012	0.1014

LTE Band 7 CA (GT - LC = -2.90 dB) 16QAM									
Bandwidth	15M+20M			20M+15M			20M + 20M		
Channel PCC	20828	21003	21179	20850	21026	21201	20850	21001	21152
	(Low)	(Mid)	(High)	(Low)	(Mid)	(High)	(Low)	(Mid)	(High)
Channel SCC	20999	21174	21350	21021	21197	21372	21048	21199	21350
	(Low)	(Mid)	(High)	(Low)	(Mid)	(High)	(Low)	(Mid)	(High)
Conducted Power (dBm)	22.89	22.75	22.92	22.69	22.87	22.75	22.81	22.75	22.76
Conducted Power (Watts)	0.1945	0.1884	0.1959	0.1858	0.1936	0.1884	0.1910	0.1884	0.1888
EIRP(dBm)	19.99	19.85	20.02	19.79	19.97	19.85	19.91	19.85	19.86
EIRP(Watts)	0.0998	0.0966	0.1005	0.0953	0.0993	0.0966	0.0979	0.0966	0.0968



LTE Band 7 CA (G _T - L _C = -2.90 dB) 64QAM									
Bandwidth	15M + 15M			10M + 20M			20M+10M		
Channel PCC	20825	21025	21225	20805	21006	21206	20850	21051	21251
	(Low)	(Mid)	(High)	(Low)	(Mid)	(High)	(Low)	(Mid)	(High)
Channel SCC	20975	21175	21375	20949	21150	21350	20994	21195	21395
	(Low)	(Mid)	(High)	(Low)	(Mid)	(High)	(Low)	(Mid)	(High)
Conducted Power (dBm)	22.18	22.38	22.60	22.76	22.38	22.59	22.38	22.75	22.86
Conducted Power (Watts)	0.1652	0.1730	0.1820	0.1888	0.1730	0.1816	0.1730	0.1884	0.1932
EIRP(dBm)	19.28	19.48	19.70	19.86	19.48	19.69	19.48	19.85	19.96
EIRP(Watts)	0.0847	0.0887	0.0933	0.0968	0.0887	0.0931	0.0887	0.0966	0.0991

LTE Band 7 CA (G _T - L _C = -2.90 dB) 64QAM									
Bandwidth	15M+20M			20M+15M			20M + 20M		
Channel PCC	20828	21003	21179	20850	21026	21201	20850	21001	21152
	(Low)	(Mid)	(High)	(Low)	(Mid)	(High)	(Low)	(Mid)	(High)
Channel SCC	20999	21174	21350	21021	21197	21372	21048	21199	21350
	(Low)	(Mid)	(High)	(Low)	(Mid)	(High)	(Low)	(Mid)	(High)
Conducted Power (dBm)	22.73	22.79	22.49	22.43	22.68	22.47	22.54	22.48	22.68
Conducted Power (Watts)	0.1875	0.1901	0.1774	0.1750	0.1854	0.1766	0.1795	0.1770	0.1854
EIRP(dBm)	19.83	19.89	19.59	19.53	19.78	19.57	19.64	19.58	19.78
EIRP(Watts)	0.0962	0.0975	0.0910	0.0897	0.0951	0.0906	0.0920	0.0908	0.0951



LTE Band 7 CA (GT - LC = -2.90 dB) QPSK			
Bandwidth	15M + 10M		
Channel PCC	20825	21025	21225
	(Low)	(Mid)	(High)
Channel SCC	20975	21175	21375
	(Low)	(Mid)	(High)
Conducted Power (dBm)	23.28	23.32	23.28
Conducted Power (Watts)	0.2128	0.2148	0.2128
EIRP(dBm)	20.38	20.42	20.38
EIRP(Watts)	0.1091	0.1102	0.1091

LTE Band 7 CA (GT - LC = -2.90 dB) 16QAM			
Bandwidth	15M + 10M		
Channel PCC	20825	21025	21225
	(Low)	(Mid)	(High)
Channel SCC	20975	21175	21375
	(Low)	(Mid)	(High)
Conducted Power (dBm)	22.58	22.76	22.62
Conducted Power (Watts)	0.1811	0.1888	0.1828
EIRP(dBm)	19.68	19.86	19.72
EIRP(Watts)	0.0929	0.0968	0.0938

LTE Band 7 CA (GT - LC = -2.90 dB) 64QAM			
Bandwidth	15M + 10M		
Channel PCC	20825	21025	21225
	(Low)	(Mid)	(High)
Channel SCC	20975	21175	21375
	(Low)	(Mid)	(High)
Conducted Power (dBm)	22.27	22.39	22.19
Conducted Power (Watts)	0.1687	0.1734	0.1656
EIRP(dBm)	19.37	19.49	19.29
EIRP(Watts)	0.0865	0.0889	0.0849



LTE Band 38 CA (GT - LC = -3.60 dB) QPSK						
Bandwidth	15M + 15M			20M+20M		
Channel PCC	37825	37925	38025	37850	37901	37952
	(Low)	(Mid)	(High)	(Low)	(Mid)	(High)
Channel SCC	37975	38075	38175	38048	38099	38150
	(Low)	(Mid)	(High)	(Low)	(Mid)	(High)
Conducted Power (dBm)	23.46	23.55	23.58	23.49	23.42	23.42
Conducted Power (Watts)	0.2218	0.2265	0.2280	0.2234	0.2198	0.2198
EIRP(dBm)	19.86	19.95	19.98	19.89	19.82	19.82
EIRP(Watts)	0.0968	0.0989	0.0995	0.0975	0.0959	0.0959

LTE Band 38 CA (GT - LC = -3.60 dB) 16QAM						
Bandwidth	15M + 15M			20M+20M		
Channel PCC	37825	37925	38025	37850	37901	37952
	(Low)	(Mid)	(High)	(Low)	(Mid)	(High)
Channel SCC	37975	38075	38175	38048	38099	38150
	(Low)	(Mid)	(High)	(Low)	(Mid)	(High)
Conducted Power (dBm)	22.83	22.86	22.85	22.85	22.63	22.94
Conducted Power (Watts)	0.1919	0.1932	0.1928	0.1928	0.1832	0.1968
EIRP(dBm)	19.23	19.26	19.25	19.25	19.03	19.34
EIRP(Watts)	0.0838	0.0843	0.0841	0.0841	0.0800	0.0859

LTE Band 38 CA (GT - LC = -3.60 dB) 64QAM						
Bandwidth	15M + 15M			20M+20M		
Channel PCC	37825	37925	38025	37850	37901	37952
	(Low)	(Mid)	(High)	(Low)	(Mid)	(High)
Channel SCC	37975	38075	38175	38048	38099	38150
	(Low)	(Mid)	(High)	(Low)	(Mid)	(High)
Conducted Power (dBm)	22.53	22.58	22.57	22.56	22.86	22.56
Conducted Power (Watts)	0.1791	0.1811	0.1807	0.1803	0.1932	0.1803
EIRP(dBm)	18.93	18.98	18.97	18.96	19.26	18.96
EIRP(Watts)	0.0782	0.0791	0.0789	0.0787	0.0843	0.0787



Peak-to-Average Ratio

Mode	LTE Band 4 / 20MHz				
Mod.	QPSK		16QAM		Limit: 13dB
RB Size	1RB	Full RB	1RB	Full RB	Result
Lowest CH	3.30	4.03	3.97	5.33	PASS
Middle CH	3.42	4.20	4.09	5.57	
Highest CH	3.54	4.26	4.26	5.54	
Mod.	64QAM		Limit: 13dB		
RB Size	1RB	Full RB	Result		
Lowest CH	5.19	5.97	PASS		
Middle CH	5.48	6.17			
Highest CH	5.57	6.23			

Mode	LTE Band 5 / 10MHz				
Mod.	QPSK		16QAM		Limit: 13dB
RB Size	1RB	Full RB	1RB	Full RB	Result
Lowest CH	3.59	4.43	4.41	5.65	PASS
Middle CH	3.68	4.38	4.84	5.68	
Highest CH	3.48	4.38	4.67	5.51	
Mod.	64QAM		Limit: 13dB		
RB Size	1RB	Full RB	Result		
Lowest CH	4.61	5.65	PASS		
Middle CH	5.16	5.65			
Highest CH	4.58	5.57			

Mode	LTE Band 7 / 20MHz				
Mod.	QPSK		16QAM		Limit: 13dB
RB Size	1RB	Full RB	1RB	Full RB	Result
Lowest CH	3.42	4.29	4.41	5.62	PASS
Middle CH	3.42	3.94	4.46	5.16	
Highest CH	3.57	4.03	4.46	5.36	
Mod.	64QAM		Limit: 13dB		
RB Size	1RB	Full RB	Result		
Lowest CH	4.38	5.54	PASS		
Middle CH	4.58	5.22			
Highest CH	4.93	5.39			



Mode	LTE Band 38 / 20MHz				
Mod.	QPSK		16QAM		Limit: 13dB
RB Size	1RB	Full RB	1RB	Full RB	Result
Lowest CH	5.42	6.06	5.97	5.77	PASS
Middle CH	6.41	4.43	5.22	6.12	
Highest CH	6.06	4.20	5.71	5.45	
Mod.	64QAM		Limit: 13dB		
RB Size	1RB	Full RB	Result		
Lowest CH	5.88	6.35	PASS		
Middle CH	6.29	6.35			
Highest CH	5.54	6.06			



LTE Band 4 / 20MHz / QPSK

Lowest Channel / 1RB

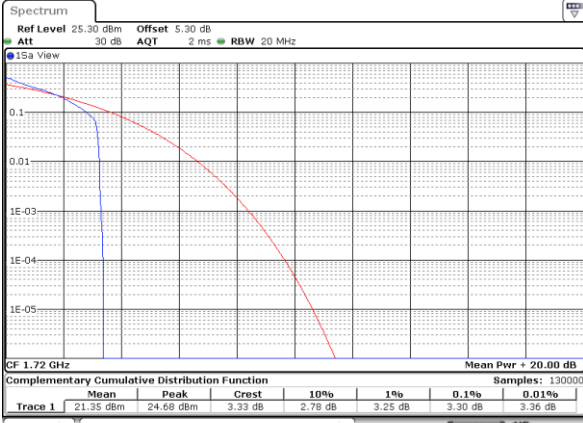

Date: 29 JUN 2018 18:48:50

Lowest Channel / Full RB

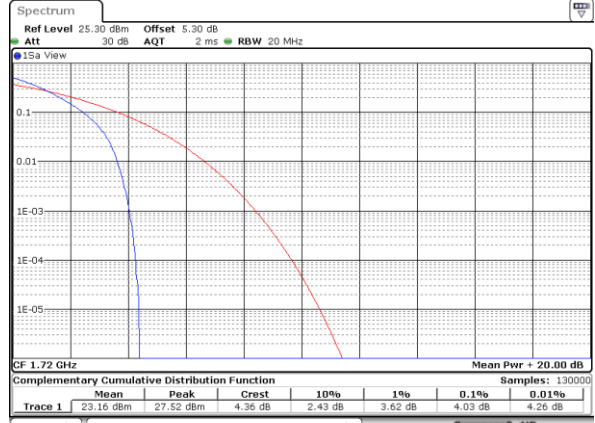

Date: 29 JUN 2018 18:50:08

Middle Channel / 1RB

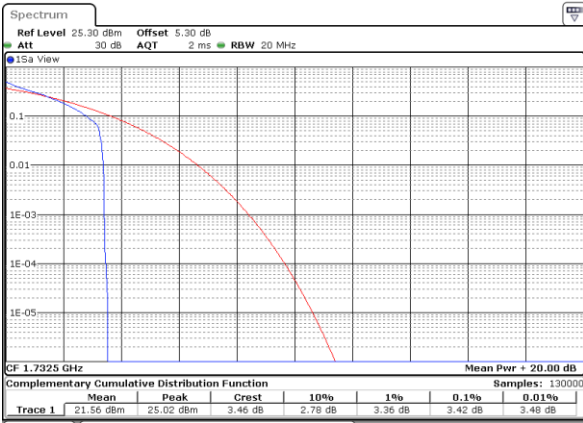

Date: 29 JUN 2018 18:49:02

Middle Channel / Full RB

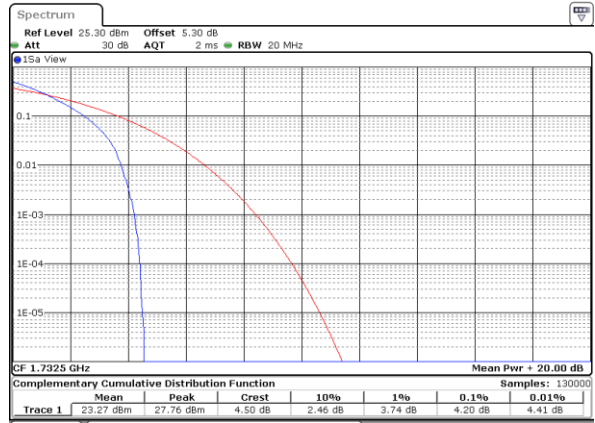

Date: 29 JUN 2018 18:49:56

Highest Channel / 1RB

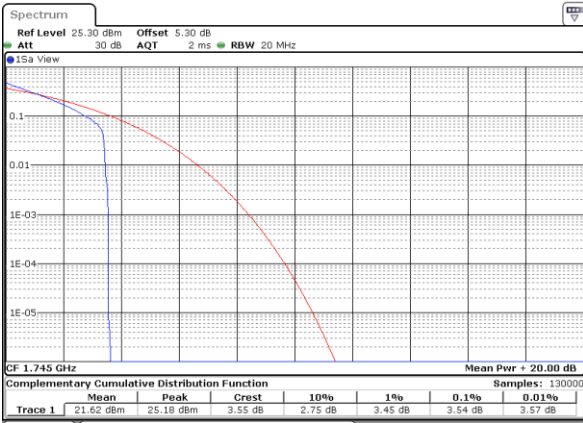

Date: 29 JUN 2018 18:49:14

Highest Channel / Full RB

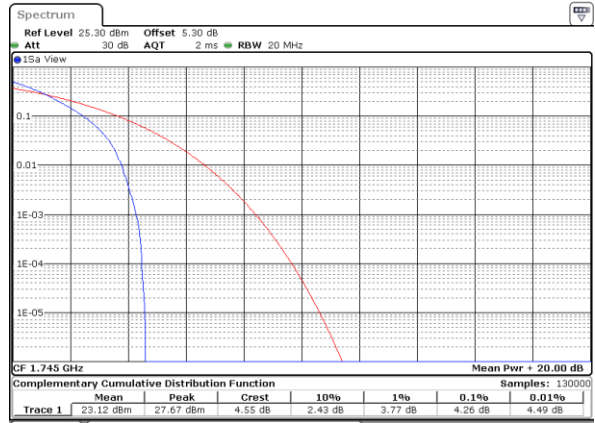

Date: 29 JUN 2018 18:49:40



LTE Band 4 / 20MHz / 16QAM

Lowest Channel / 1RB

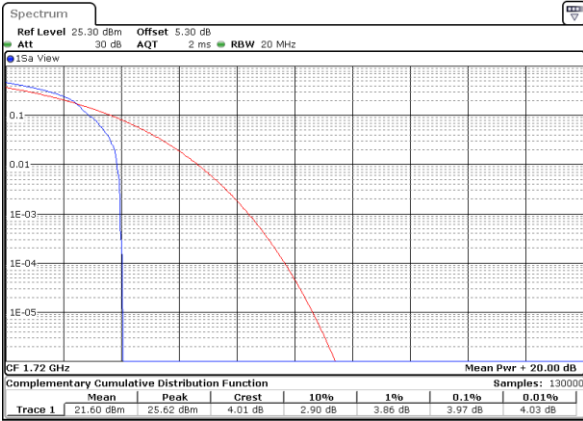

Date: 29 JUN 2018 17:01:11

Lowest Channel / Full RB

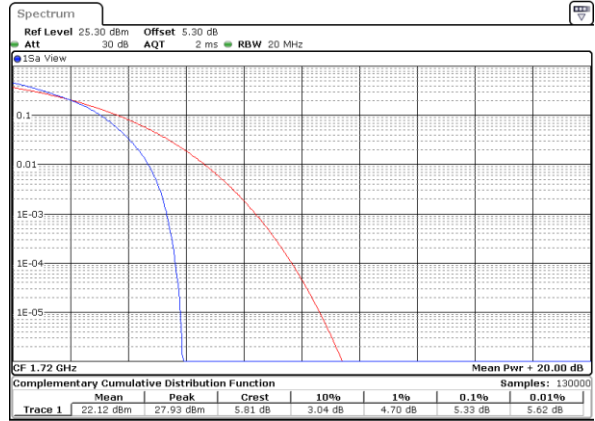

Date: 29 JUN 2018 17:01:20

Middle Channel / 1RB

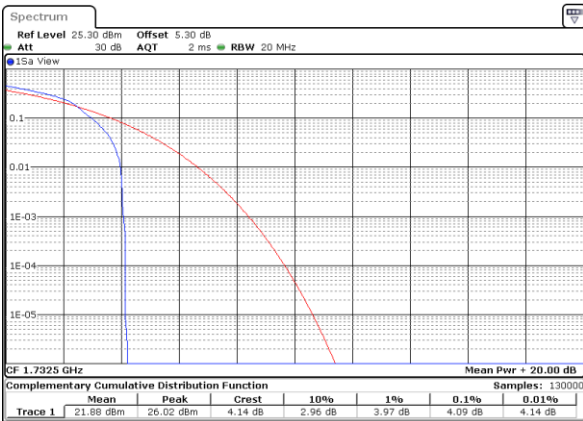

Date: 29 JUN 2018 17:01:30

Middle Channel / Full RB

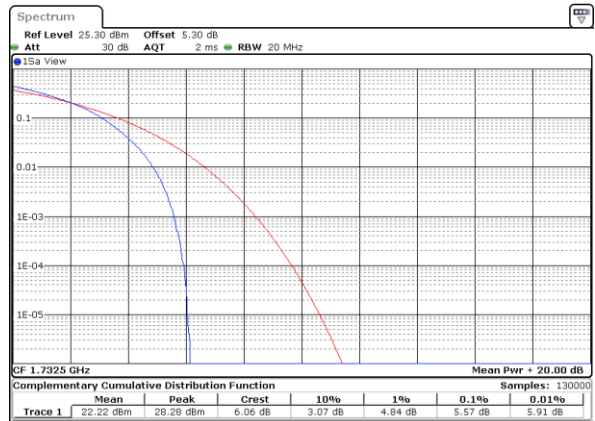

Date: 29 JUN 2018 17:01:39

Highest Channel / 1RB



Date: 29 JUN 2018 17:01:48

Highest Channel / Full RB



Date: 29 JUN 2018 17:01:57



LTE Band 4 / 20MHz / 64QAM

Lowest Channel / 1RB



Date: 29 JUN 2018 17:54:43

Lowest Channel / Full RB

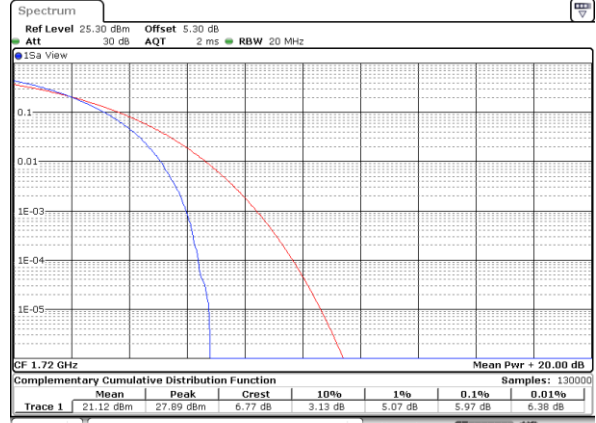

Date: 29 JUN 2018 17:54:33

Middle Channel / 1RB

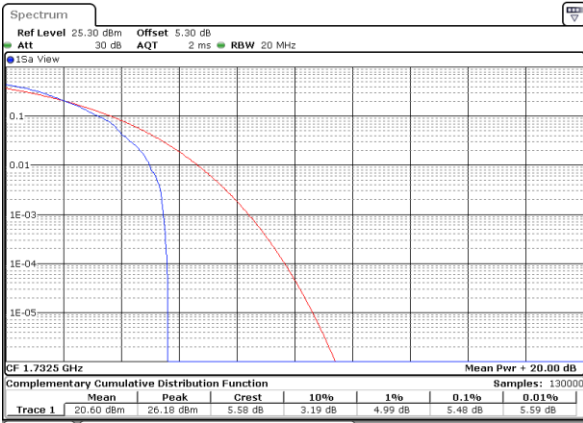

Date: 29 JUN 2018 17:54:52

Middle Channel / Full RB

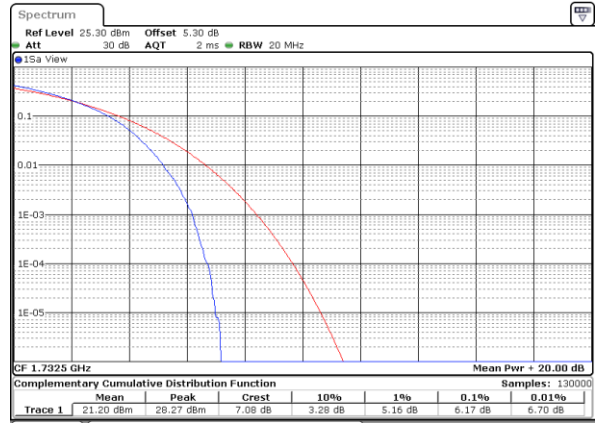

Date: 29 JUN 2018 17:55:00

Highest Channel / 1RB

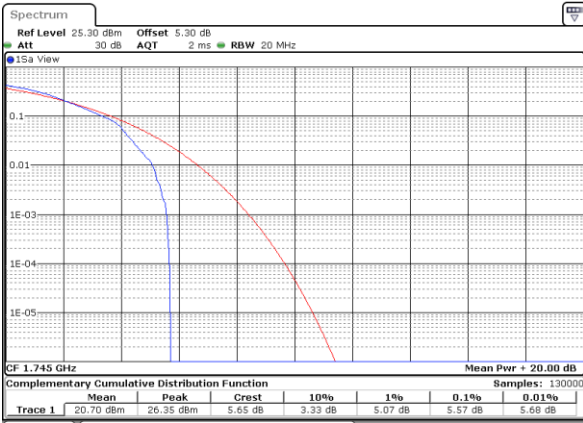

Date: 29 JUN 2018 17:54:16

Highest Channel / Full RB

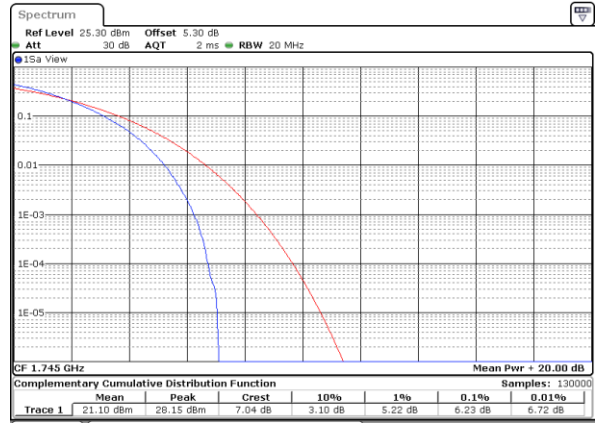

Date: 29 JUN 2018 17:54:24



LTE Band 5 / 10MHz / QPSK

Lowest Channel / 1RB

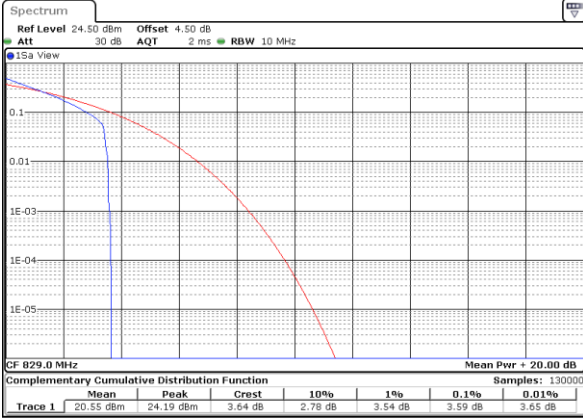

Date: 2 JUL 2018 11:42:47

Lowest Channel / Full RB

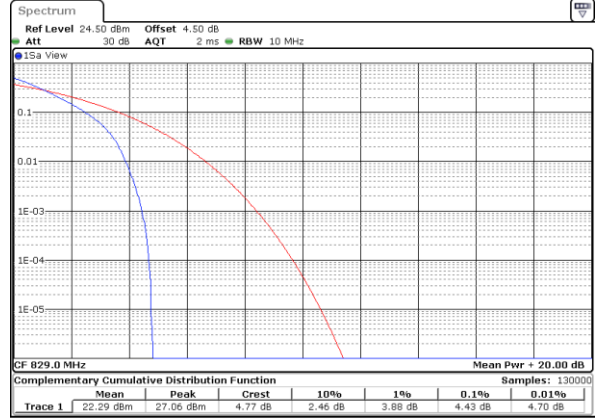

Date: 2 JUL 2018 11:43:06

Middle Channel / 1RB

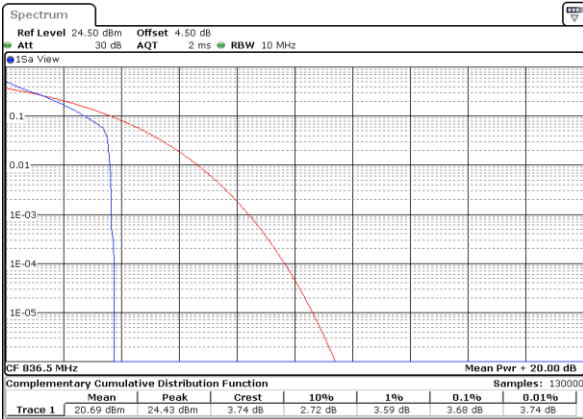

Date: 2 JUL 2018 11:43:25

Middle Channel / Full RB

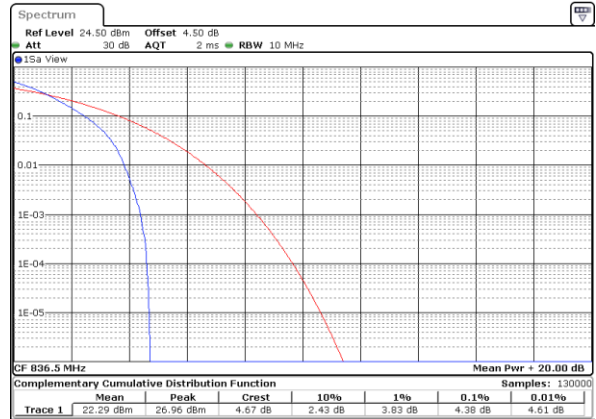

Date: 2 JUL 2018 11:43:44

Highest Channel / 1RB

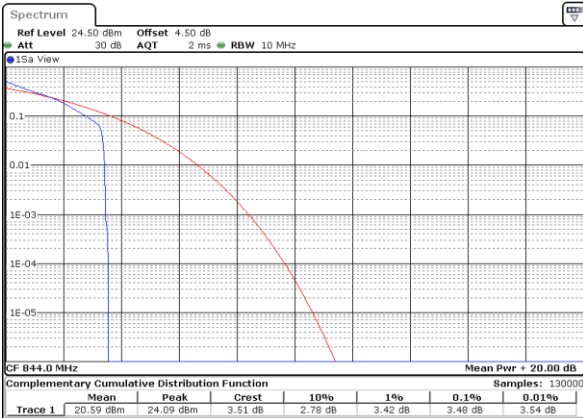

Date: 2 JUL 2018 11:44:09

Highest Channel / Full RB

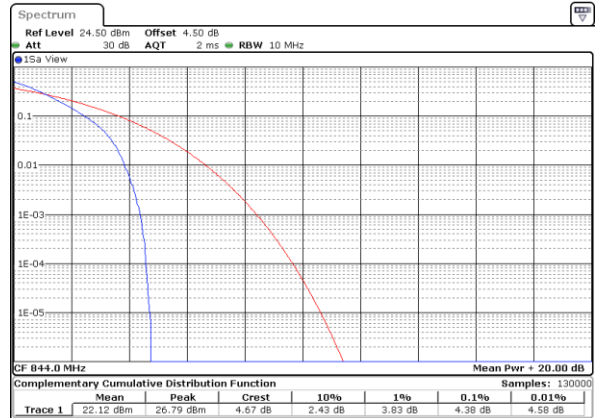

Date: 2 JUL 2018 11:44:38



LTE Band 5 / 10MHz / 16QAM

Lowest Channel / 1RB

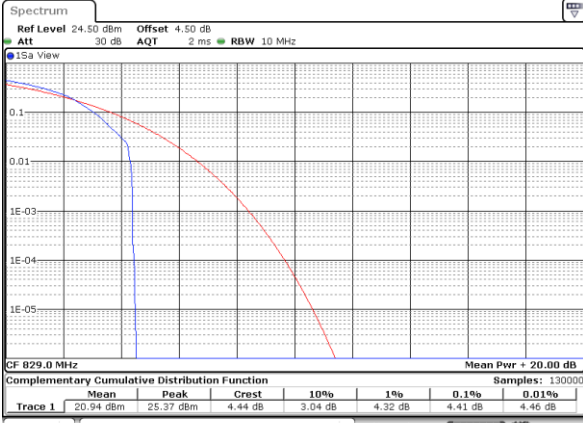

Date: 2 JUL 2018 10:51:54

Lowest Channel / Full RB

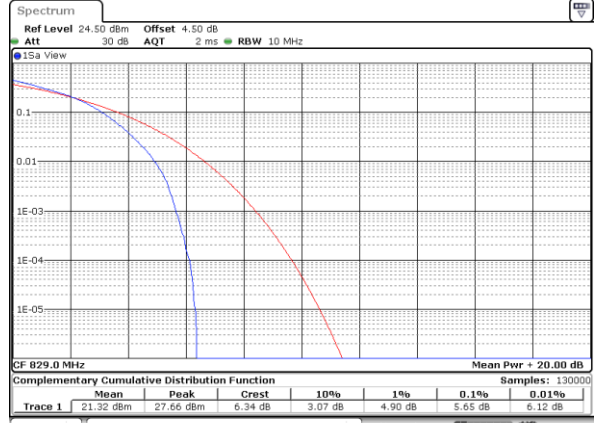

Date: 2 JUL 2018 10:52:04

Middle Channel / 1RB

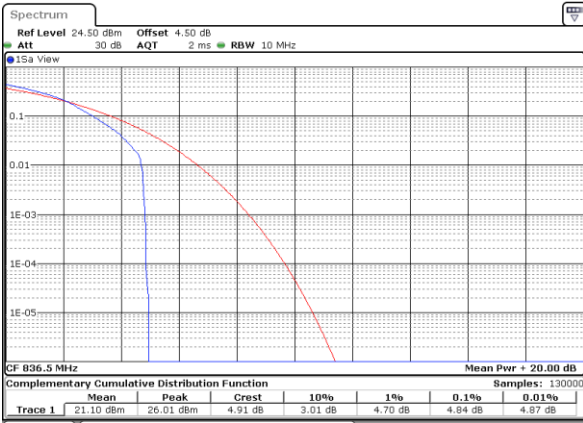

Date: 2 JUL 2018 10:52:14

Middle Channel / Full RB

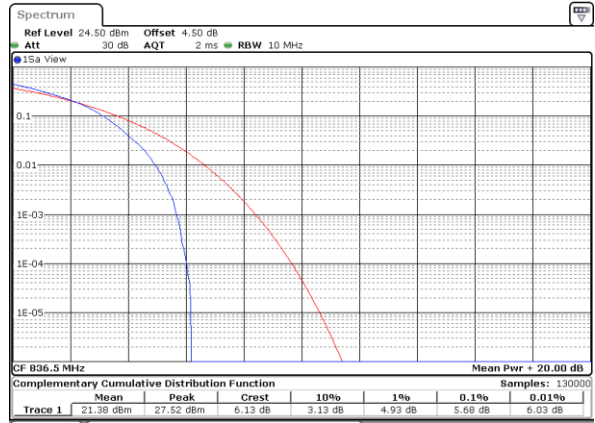

Date: 2 JUL 2018 10:52:24

Highest Channel / 1RB

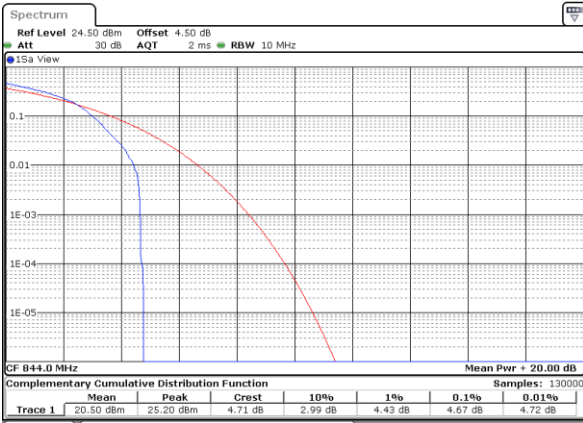

Date: 2 JUL 2018 10:52:33

Highest Channel / Full RB

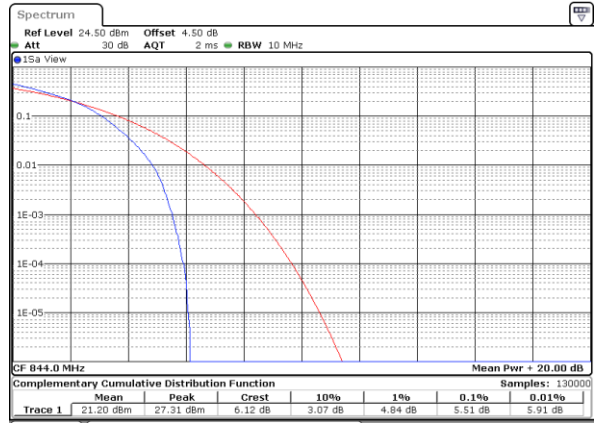

Date: 2 JUL 2018 10:52:43



LTE Band 5 / 10MHz / 64QAM

Lowest Channel / 1RB

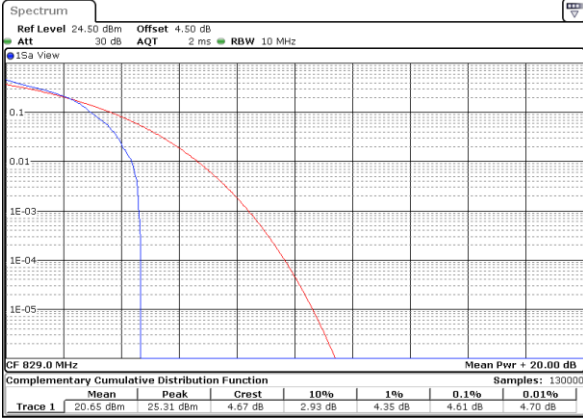

Date: 2 JUL 2018 11:42:56

Lowest Channel / Full RB

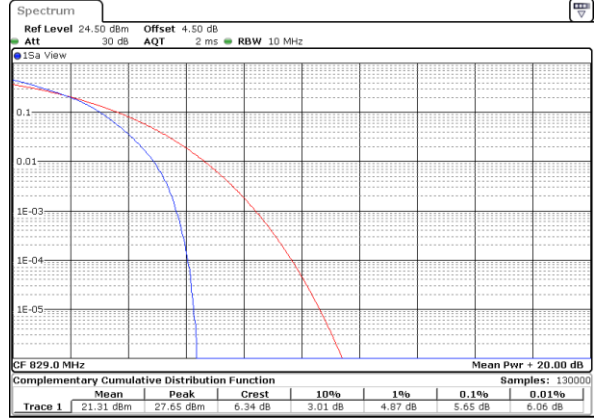

Date: 2 JUL 2018 11:43:15

Middle Channel / 1RB

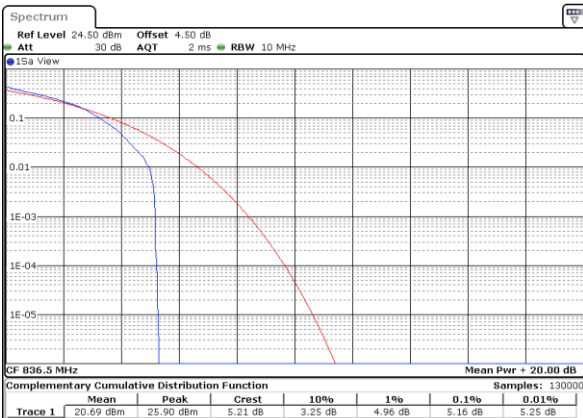

Date: 2 JUL 2018 11:43:35

Middle Channel / Full RB

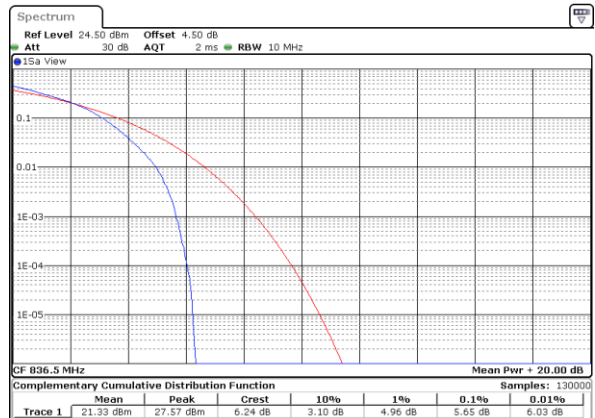

Date: 2 JUL 2018 11:43:55

Highest Channel / 1RB

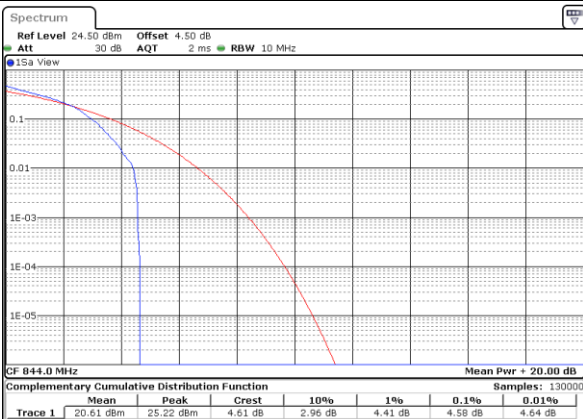

Date: 2 JUL 2018 11:44:19

Highest Channel / Full RB



Date: 2 JUL 2018 11:44:48



LTE Band 7 / 20MHz / QPSK

Lowest Channel / 1RB

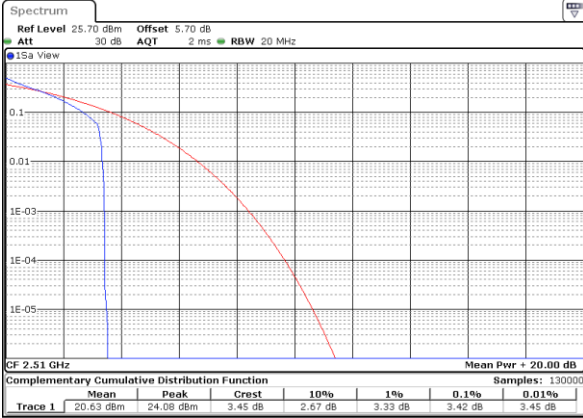

Date: 2 JUL 2018 16:29:33

Lowest Channel / Full RB

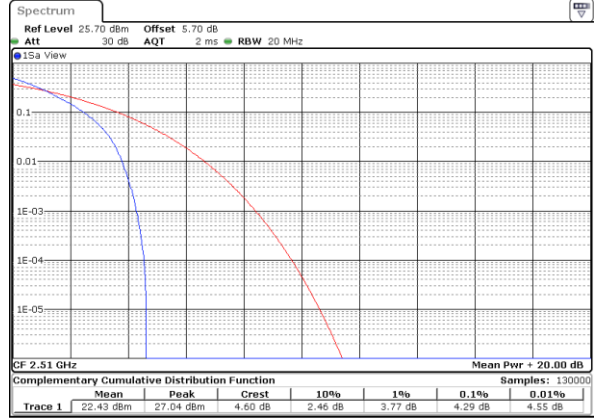

Date: 2 JUL 2018 16:30:03

Middle Channel / 1RB



Date: 2 JUL 2018 16:30:45

Middle Channel / Full RB

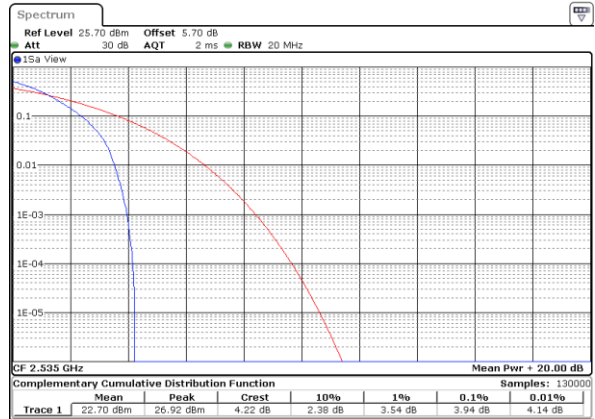

Date: 2 JUL 2018 16:30:14

Highest Channel / 1RB

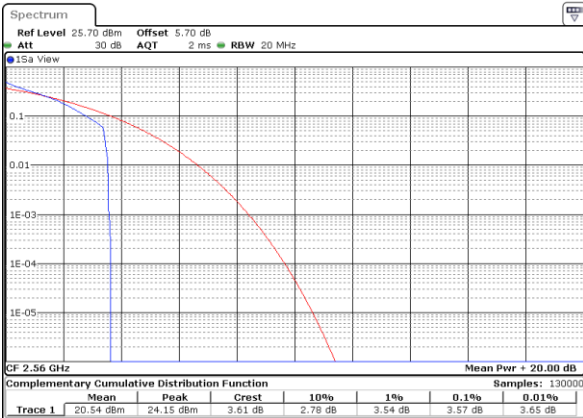

Date: 2 JUL 2018 16:30:55

Highest Channel / Full RB

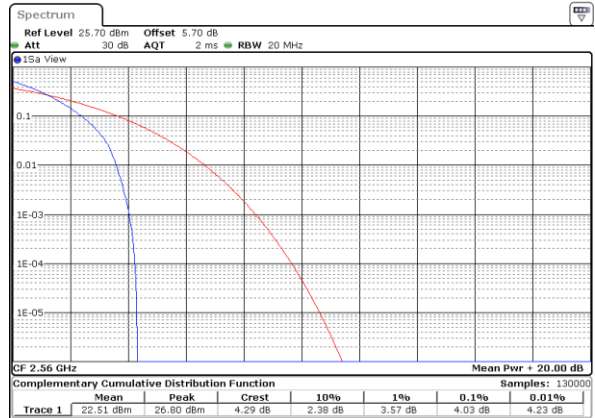

Date: 2 JUL 2018 16:31:26



LTE Band 7 / 20MHz / 16QAM

Lowest Channel / 1RB

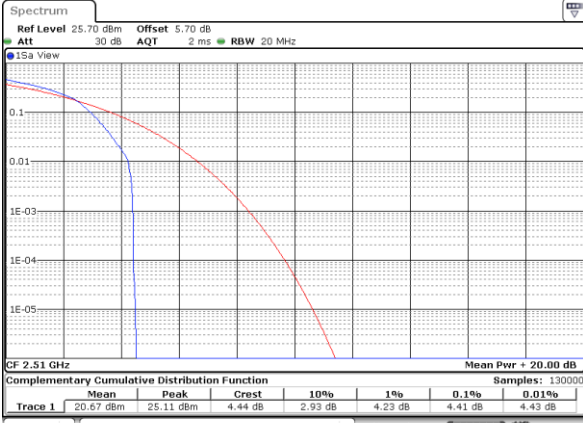

Date: 2 JUL 2018 16:29:44

Lowest Channel / Full RB

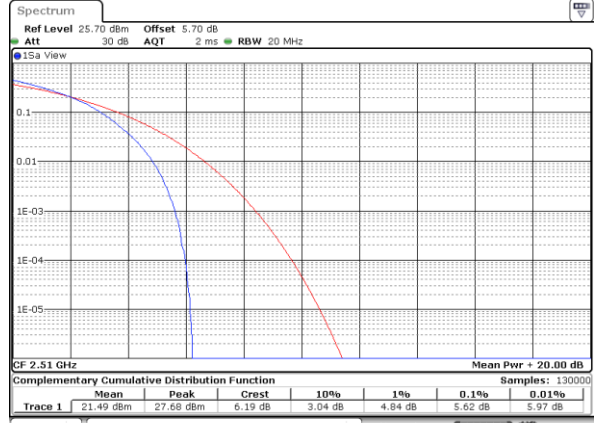

Date: 2 JUL 2018 16:29:53

Middle Channel / 1RB

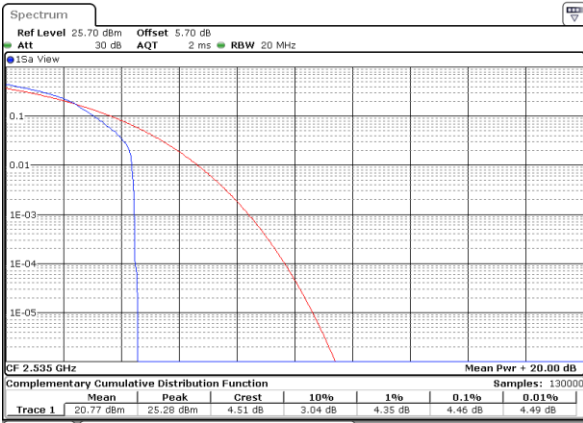

Date: 2 JUL 2018 16:30:35

Middle Channel / Full RB

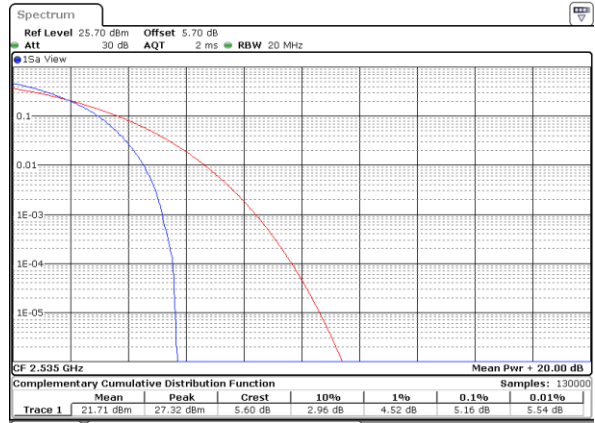

Date: 2 JUL 2018 16:30:24

Highest Channel / 1RB

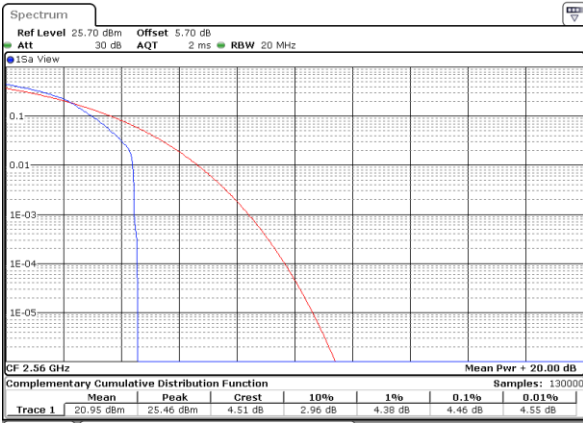

Date: 2 JUL 2018 16:31:06

Highest Channel / Full RB

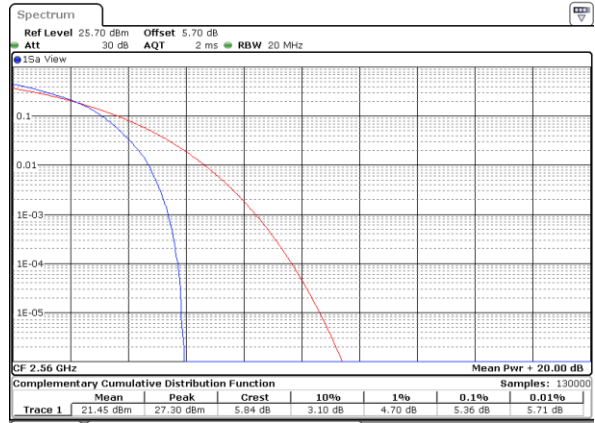

Date: 2 JUL 2018 16:31:16



LTE Band 7 / 20MHz / 64QAM

Lowest Channel / 1RB

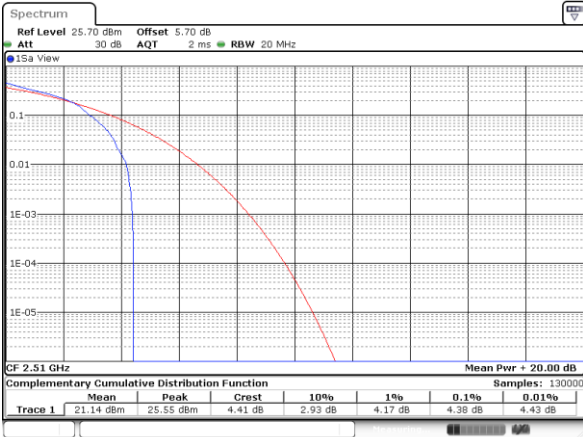

Date: 3 JUL 2018 09:44:01

Lowest Channel / Full RB

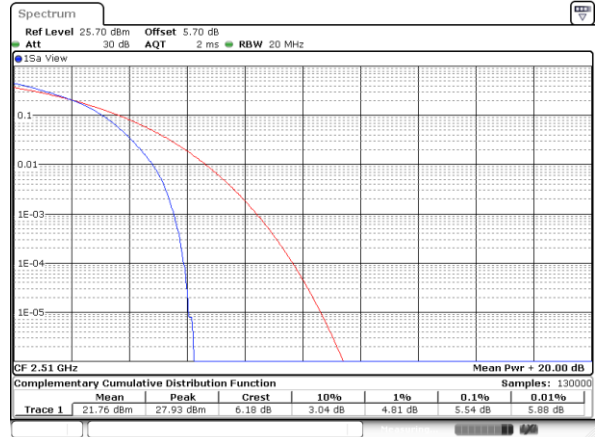

Date: 3 JUL 2018 09:44:20

Middle Channel / 1RB

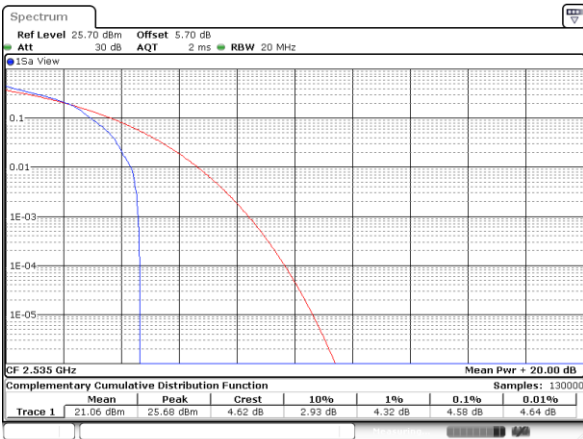

Date: 3 JUL 2018 09:44:45

Middle Channel / Full RB

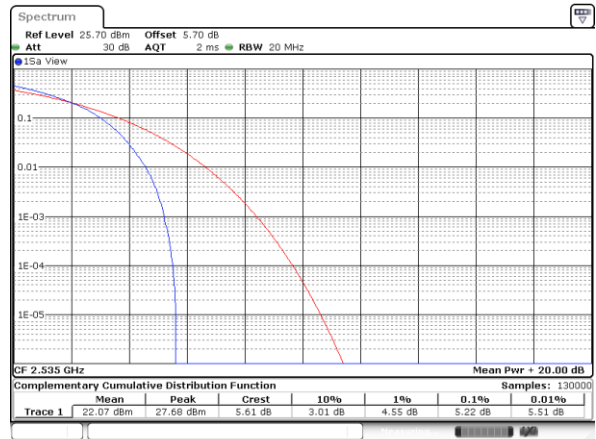

Date: 3 JUL 2018 09:44:33

Highest Channel / 1RB

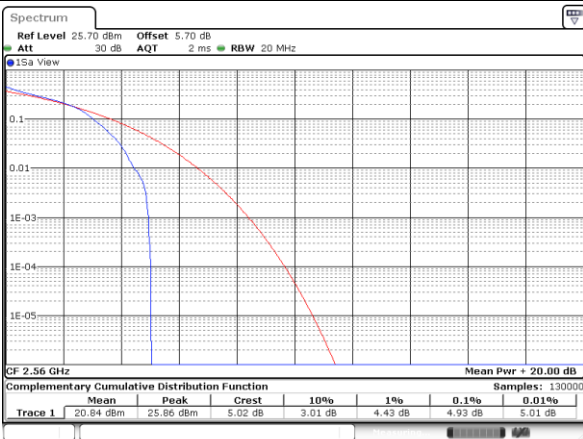

Date: 3 JUL 2018 09:45:02

Highest Channel / Full RB

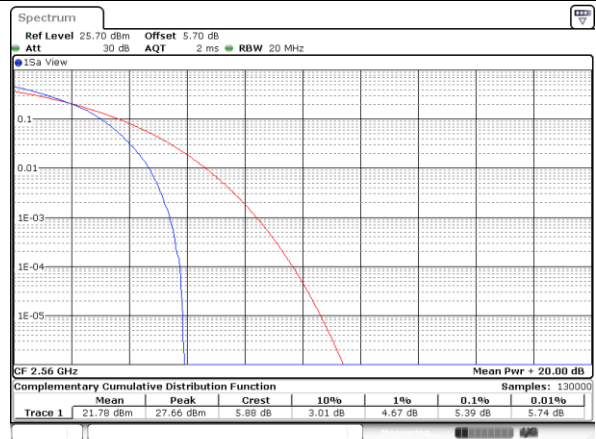

Date: 3 JUL 2018 09:45:15



LTE Band 38 / 20MHz / QPSK

Lowest Channel / 1RB

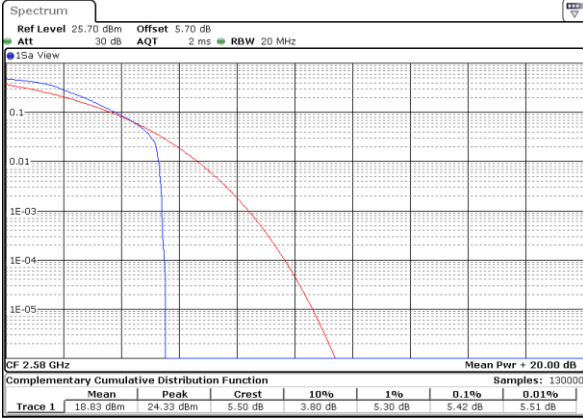

Date: 2 JUL 2018 15:06:16

Lowest Channel / Full RB

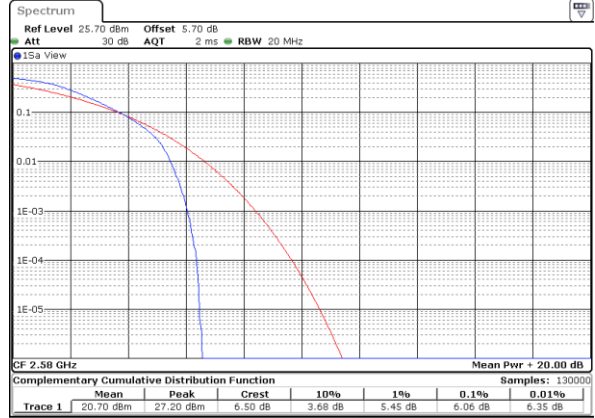

Date: 2 JUL 2018 15:08:36

Middle Channel / 1RB

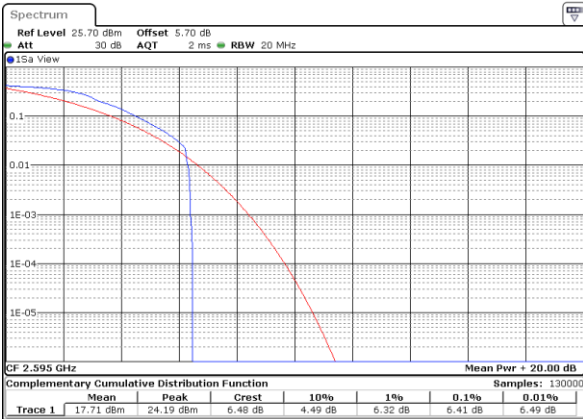

Date: 2 JUL 2018 15:05:58

Middle Channel / Full RB

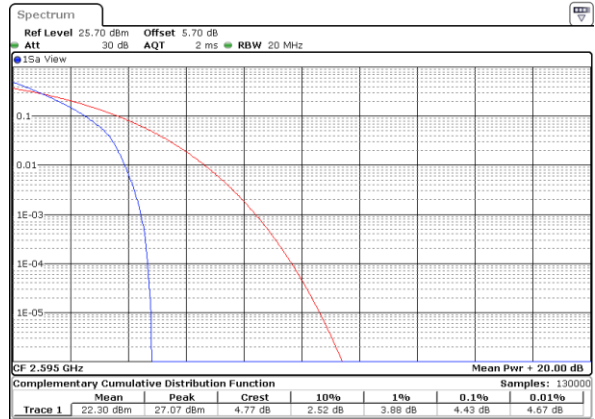

Date: 2 JUL 2018 15:04:08

Highest Channel / 1RB

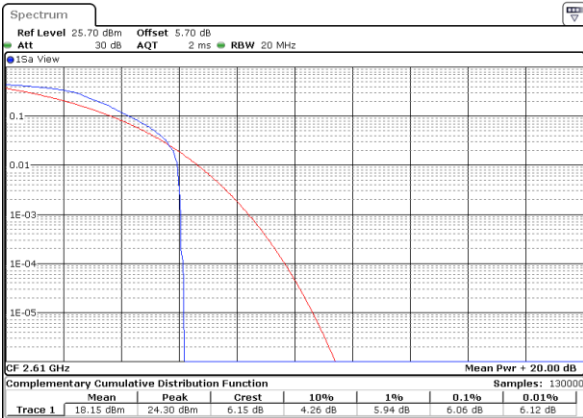

Date: 2 JUL 2018 15:02:07

Highest Channel / Full RB

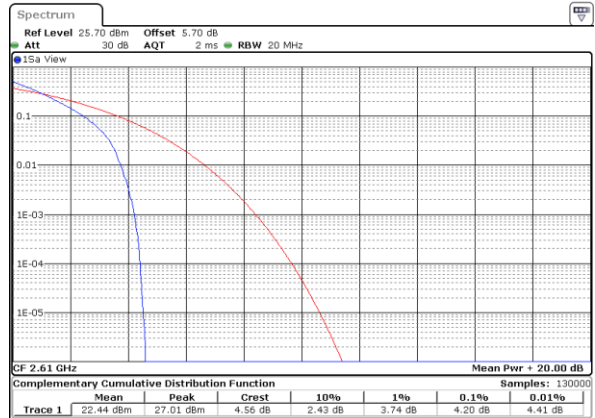

Date: 2 JUL 2018 15:03:52



LTE Band 38 / 20MHz / 16QAM

Lowest Channel / 1RB

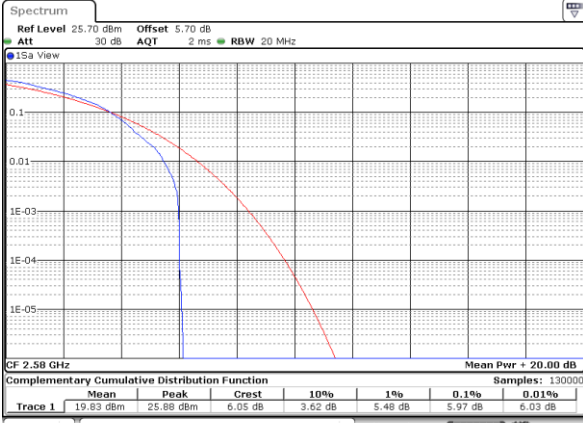

Date: 2 JUL 2018 15:06:34

Lowest Channel / Full RB

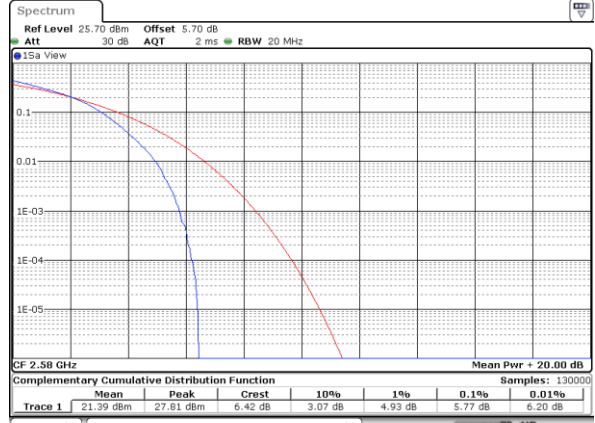

Date: 2 JUL 2018 15:08:22

Middle Channel / 1RB

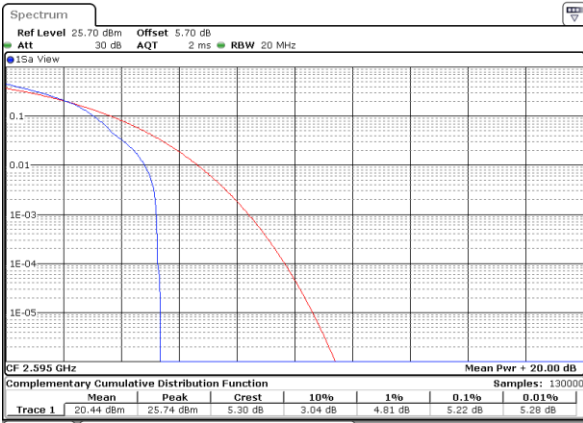

Date: 2 JUL 2018 15:05:42

Middle Channel / Full RB

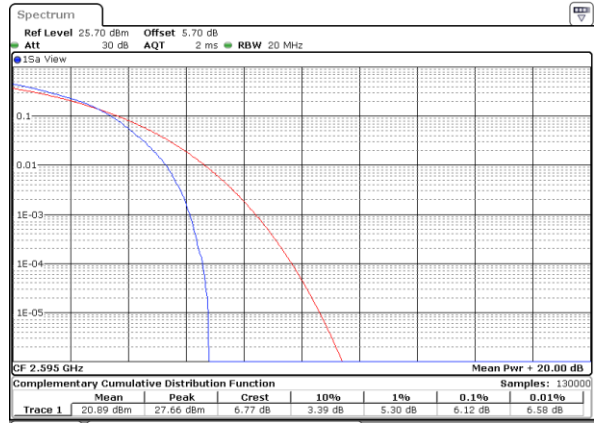

Date: 2 JUL 2018 15:04:21

Highest Channel / 1RB

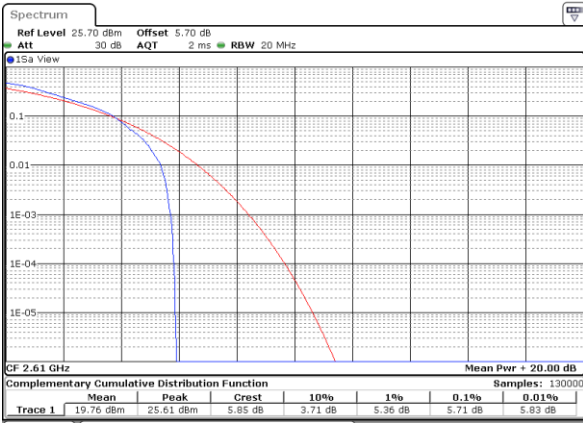

Date: 2 JUL 2018 15:02:32

Highest Channel / Full RB

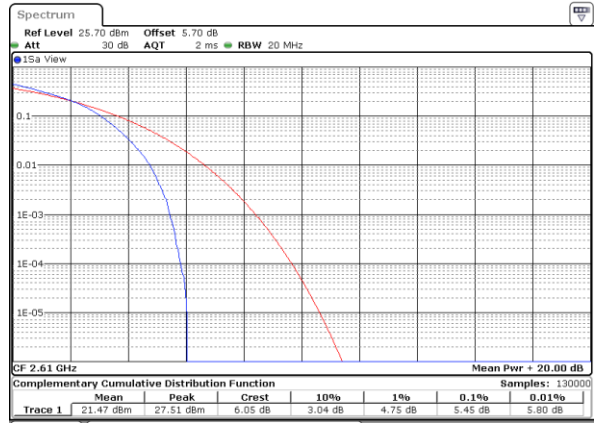

Date: 2 JUL 2018 15:03:30



LTE Band 38 / 20MHz / 64QAM

Lowest Channel / 1RB

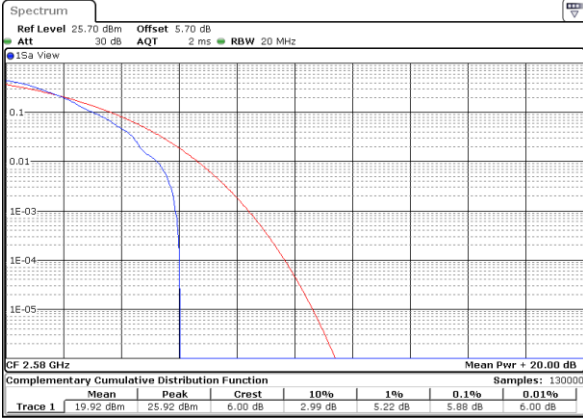

Date: 2 JUL 2018 15:06:50

Lowest Channel / Full RB

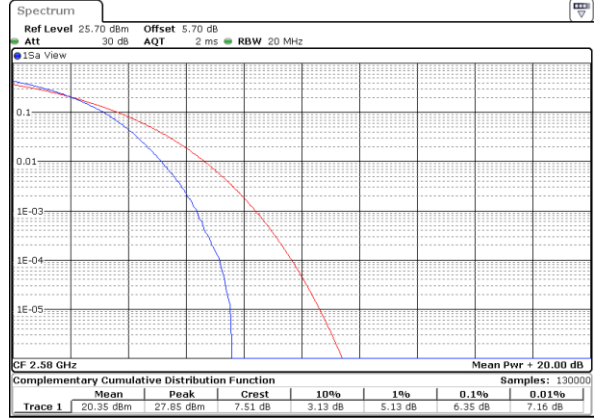

Date: 2 JUL 2018 15:07:25

Middle Channel / 1RB

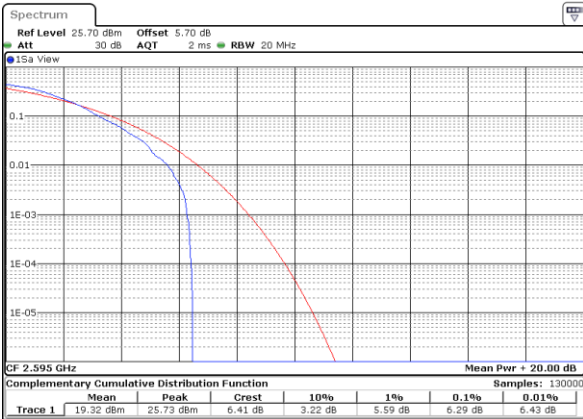

Date: 2 JUL 2018 15:05:28

Middle Channel / Full RB

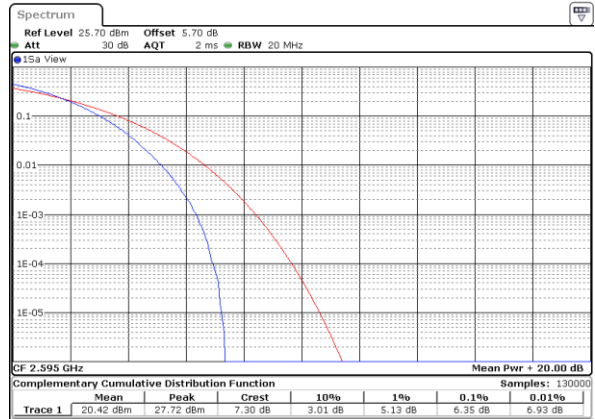

Date: 2 JUL 2018 15:04:52

Highest Channel / 1RB

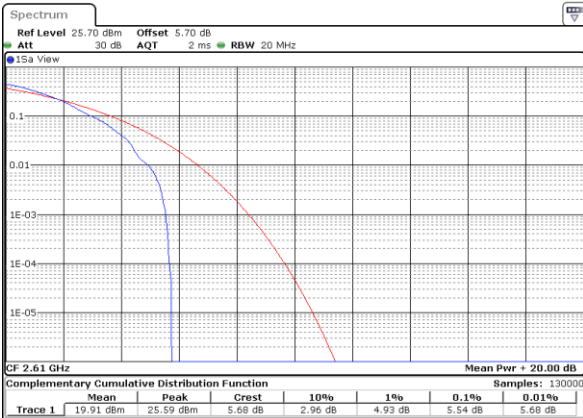

Date: 2 JUL 2018 15:02:52

Highest Channel / Full RB

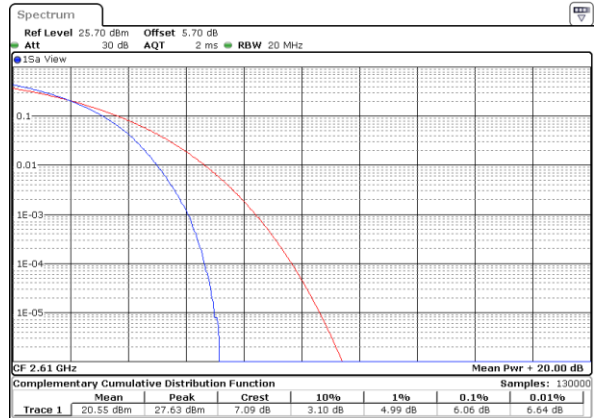

Date: 2 JUL 2018 15:03:07



26dB Bandwidth

Mode	LTE Band 4 : 26dB BW(MHz)											
	1.4MHz		3MHz		5MHz		10MHz		15MHz		20MHz	
Mod.	QPSK	16QAM	QPSK	16QAM	QPSK	16QAM	QPSK	16QAM	QPSK	16QAM	QPSK	16QAM
Lowest CH	1.236	1.234	3.003	3.009	4.925	4.885	9.73	9.81	14.386	14.416	20.18	20.06
Middle CH	1.217	1.225	3.003	3.021	4.925	4.915	9.79	9.75	14.625	14.326	20.26	20.22
Highest CH	1.211	1.222	3.027	3.003	4.885	4.905	9.93	9.91	14.266	14.116	20.22	20.1
BW	1.4MHz		3MHz		5MHz		10MHz		15MHz		20MHz	
Mod.	64QAM		64QAM		64QAM		64QAM		64QAM		64QAM	
Lowest CH	1.228		3.051		4.905		9.79		14.476		20.14	
Middle CH	1.231		3.003		4.935		9.71		14.416		20.1	
Highest CH	1.22		3.063		4.975		9.81		14.356		20.06	

Mode	LTE Band 5 : 26dB BW(MHz)									
	1.4MHz		3MHz		5MHz		10MHz			
Mod.	QPSK	16QAM	QPSK	16QAM	QPSK	16QAM	QPSK	16QAM		
Lowest CH	1.231	1.236	3.003	3.027	4.965	4.855	9.71	9.91		
Middle CH	1.225	1.231	3.051	2.997	4.845	4.885	9.85	9.73		
Highest CH	1.236	1.234	2.985	3.027	4.895	4.895	9.73	9.81		
BW	1.4MHz		3MHz		5MHz		10MHz			
Mod.	64QAM		64QAM		64QAM		64QAM			
Lowest CH	1.234		3.027		4.825		9.79			
Middle CH	1.211		3.039		4.905		9.75			
Highest CH	1.248		3.021		4.885		9.73			

Mode	LTE Band 7 : 26dB BW(MHz)											
					5MHz		10MHz		15MHz		20MHz	
Mod.					QPSK	16QAM	QPSK	16QAM	QPSK	16QAM	QPSK	16QAM
Lowest CH					4.905	4.815	9.91	9.87	14.386	14.296	20.14	20.1
Middle CH					4.845	4.885	9.73	9.87	14.386	14.535	20.3	20.22
Highest CH					4.905	4.875	9.77	9.69	14.296	14.206	20.06	20.46
BW					5MHz		10MHz		15MHz		20MHz	
Mod.					64QAM		64QAM		64QAM		64QAM	
Lowest CH					4.965		9.79		14.446		20.02	
Middle CH					4.885		9.75		14.086		20.14	
Highest CH					4.835		9.77		14.386		20.1	



Mode	LTE Band 38 : 26dB BW(MHz)											
BW				5MHz		10MHz		15MHz		20MHz		
Mod.				QPSK	16QAM	QPSK	16QAM	QPSK	16QAM	QPSK	16QAM	
Lowest CH				4.825	4.875	9.67	9.75	14.356	14.296	20.06	19.94	
Middle CH				4.885	4.925	9.67	9.73	14.236	14.206	20.06	20.14	
Highest CH				4.905	4.915	9.77	9.65	14.356	14.565	20.02	20.02	
BW				5MHz		10MHz		15MHz		20MHz		
Mod.				64QAM		64QAM		64QAM		64QAM		
Lowest CH				4.815		9.71		14.296		20.1		
Middle CH				4.815		9.79		14.206		20.18		
Highest CH				4.895		9.85		14.206		20.1		



For CA

Mode	LTE Band 7 : 26dB BW(MHz)			
QPSK				
BW	10MHz+20MHz	-	15MHz+10MHz	15MHz+15MHz
Lowest CH	30.03	-	25.375	30.749
Middle CH	30.03	-	25.475	30.39
Highest CH	30.09	-	25.475	30.569
BW	15MHz+20MHz	20MHz+10MHz	20MHz+15MHz	20MHz+20MHz
Lowest CH	34.965	30.21	34.965	39.96
Middle CH	34.895	29.97	34.895	40.04
Highest CH	34.965	30.15	35.175	40.04

Mode	LTE Band 7 : 26dB BW(MHz)			
16QAM				
BW	10MHz+20MHz	-	15MHz+10MHz	15MHz+15MHz
Lowest CH	29.97	-	25.275	30.509
Middle CH	29.79	-	25.425	30.45
Highest CH	29.85	-	25.375	30.509
BW	15MHz+20MHz	20MHz+10MHz	20MHz+15MHz	20MHz+20MHz
Lowest CH	34.965	30.15	34.965	39.96
Middle CH	34.825	29.97	34.825	39.96
Highest CH	34.825	30.09	35.105	40.04

Mode	LTE Band 7 : 26dB BW(MHz)			
64QAM				
BW	10MHz+20MHz	-	15MHz+10MHz	15MHz+15MHz
Lowest CH	29.97	-	25.425	30.629
Middle CH	29.85	-	25.475	30.509
Highest CH	29.85	-	25.375	30.509
BW	15MHz+20MHz	20MHz+10MHz	20MHz+15MHz	20MHz+20MHz
Lowest CH	34.895	30.09	34.895	39.96
Middle CH	34.825	30.03	35.035	39.72
Highest CH	34.895	30.09	35.035	39.96



Mode	LTE Band 38 : 26dB BW(MHz)			
Mod.	QPSK		16QAM	
BW	15MHz+15MHz	20MHz+20MHz	15MHz+15MHz	20MHz+20MHz
Lowest CH	30.749	40.04	30.629	39.96
Middle CH	30.569	39.96	30.749	39.88
Highest CH	30.629	39.96	30.749	39.96

Mode	LTE Band 38 : 26dB BW(MHz)			
Mod.	64QAM		-	
BW	15MHz+15MHz	20MHz+20MHz	-	-
Lowest CH	30.629	39.96	-	-
Middle CH	30.629	39.96	-	-
Highest CH	30.629	39.80	-	-



LTE Band 4

Lowest Channel / 1.4MHz / QPSK

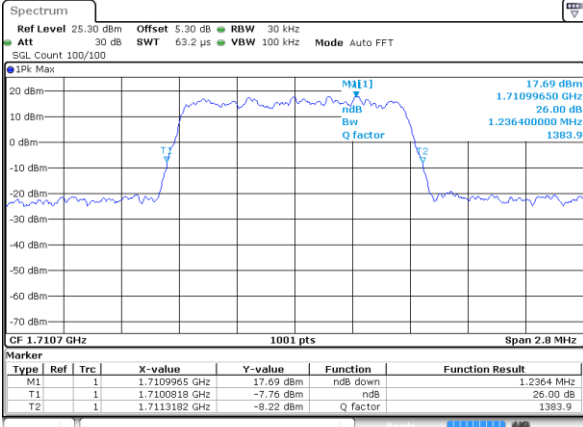

Date: 29 JUN 2018 15:21:49

Lowest Channel / 1.4MHz / 16QAM

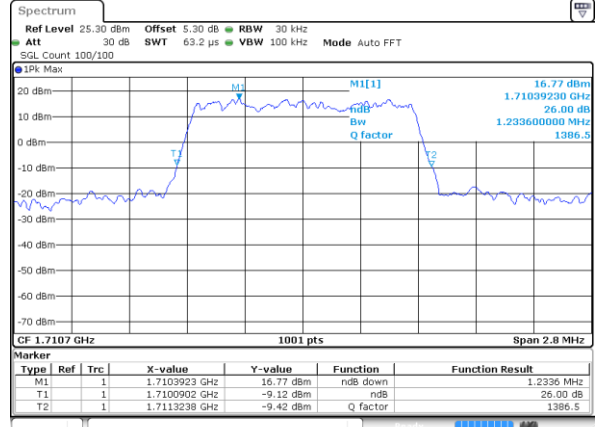

Date: 29 JUN 2018 15:21:59

Middle Channel / 1.4MHz / QPSK

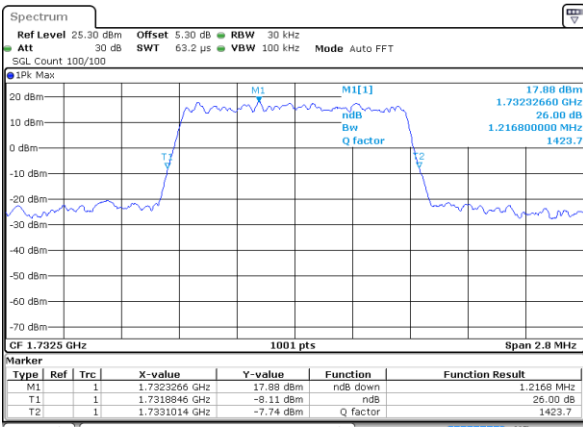

Date: 29 JUN 2018 15:28:48

Middle Channel / 1.4MHz / 16QAM

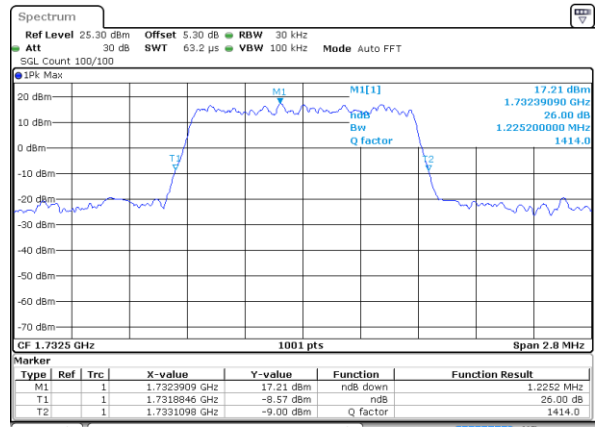

Date: 29 JUN 2018 15:28:58

Highest Channel / 1.4MHz / QPSK

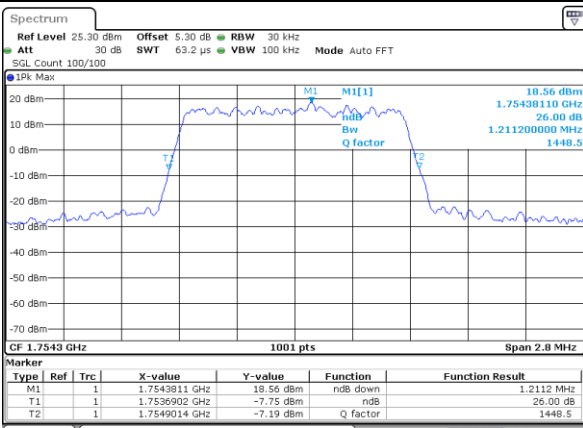

Date: 29 JUN 2018 15:31:18

Highest Channel / 1.4MHz / 16QAM

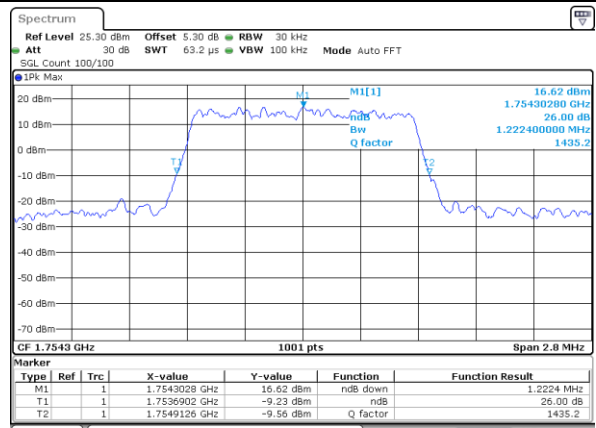

Date: 29 JUN 2018 15:31:27



LTE Band 4

Lowest Channel / 3MHz / QPSK

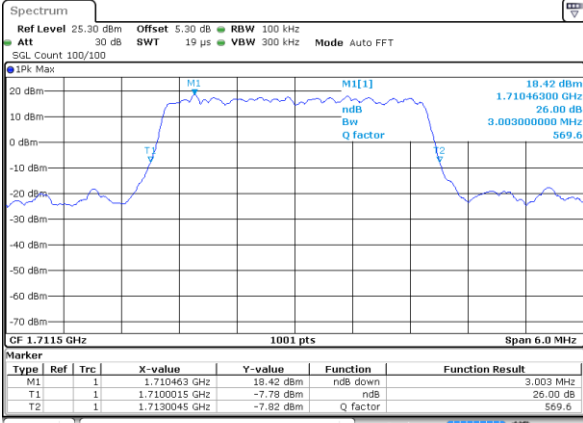

Date: 29 JUN 2018 15:38:16

Lowest Channel / 3MHz / 16QAM

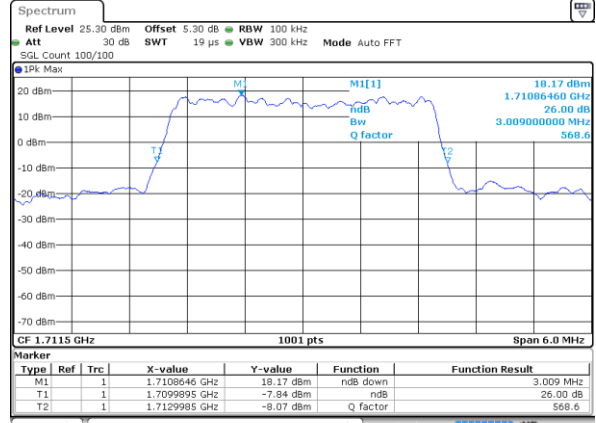

Date: 29 JUN 2018 15:38:26

Middle Channel / 3MHz / QPSK

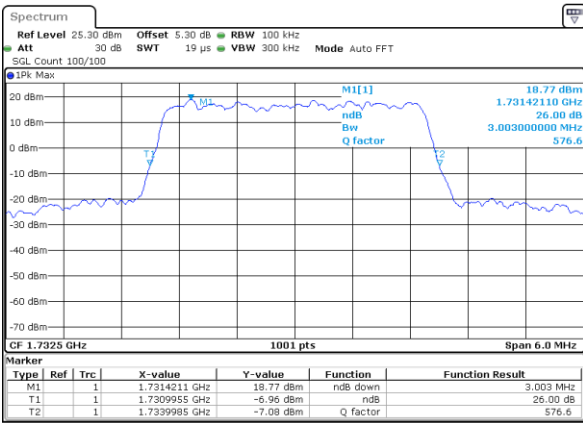

Date: 29 JUN 2018 15:45:15

Middle Channel / 3MHz / 16QAM

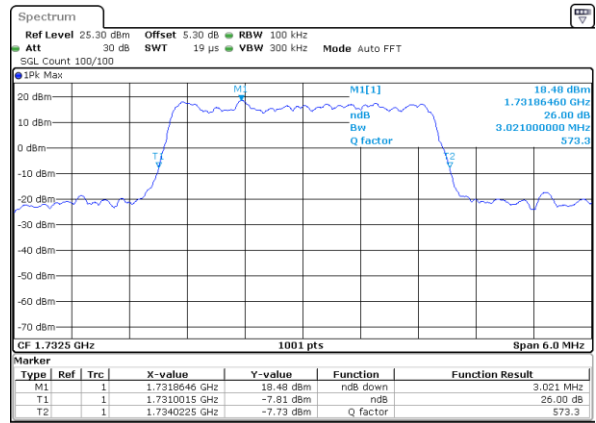

Date: 29 JUN 2018 15:45:25

Highest Channel / 3MHz / QPSK

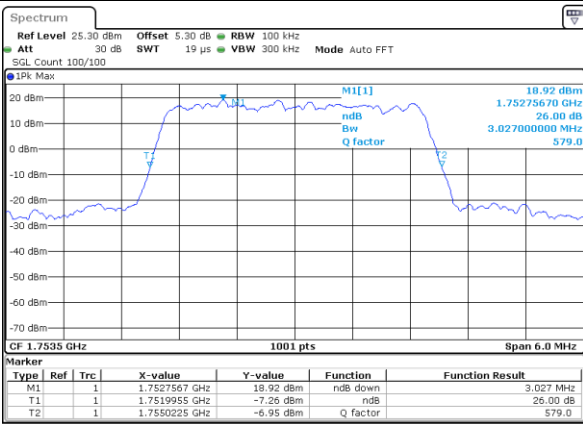

Date: 29 JUN 2018 15:47:44

Highest Channel / 3MHz / 16QAM

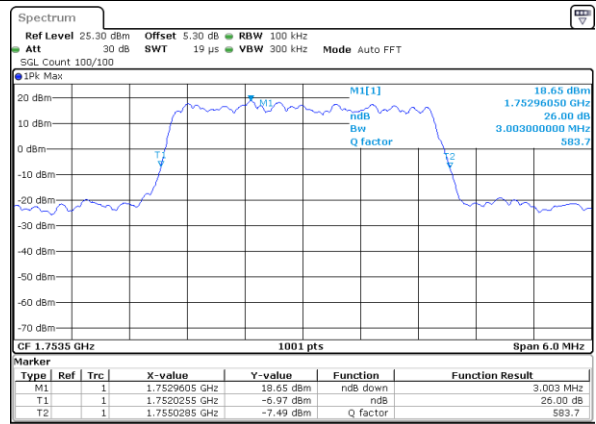

Date: 29 JUN 2018 15:47:54