



FCC RF Test Report

APPLICANT : Ignition Design Labs (US) LLC
EQUIPMENT : Advanced Wireless Router
BRAND NAME : Ignition Design Labs
MODEL NAME : Portal
MARKETING NAME : Portal
FCC ID : 2AFZUSAP102
STANDARD : FCC Part 15 Subpart E §15.407
CLASSIFICATION : (NII) Unlicensed National Information Infrastructure

This is a variant report which is only valid together with the original test report. The product was received on May 20, 2016 and testing was completed on Jul. 26, 2016. We, SPORTON INTERNATIONAL INC., would like to declare that the tested sample has been evaluated in accordance with the test procedures and has been in compliance with the applicable technical standards.

The test results in this report apply exclusively to the tested model / sample. Without written approval of SPORTON INTERNATIONAL INC., the test report shall not be reproduced except in full.

Reviewed by: Joseph Lin / Supervisor

Approved by: Jones Tsai / Manager



SPORTON INTERNATIONAL INC.

No. 52, Hwa Ya 1st Rd., Hwa Ya Technology Park, Kwei-Shan District, Tao Yuan City, Taiwan, R.O.C.

SPORTON INTERNATIONAL INC.

TEL : 886-3-327-3456

FAX : 886-3-328-4978

FCC ID : 2AFZUSAP102

Page Number : 1 of 41

Report Issued Date : Jul. 28, 2016

Report Version : Rev. 01

Report Template No.: BU5-FR15EWLAC MA Version 1.4



TABLE OF CONTENTS

REVISION HISTORY 3

SUMMARY OF TEST RESULT 4

1 GENERAL DESCRIPTION 5

 1.1 Applicant 5

 1.2 Manufacturer 5

 1.3 Product Feature of Equipment Under Test 5

 1.4 Product Specification of Equipment Under Test 6

 1.5 Modification of EUT 6

 1.6 Testing Location 7

 1.7 Applicable Standards 8

2 TEST CONFIGURATION OF EQUIPMENT UNDER TEST 9

 2.1 Carrier Frequency and Channel 9

 2.2 Test Mode 10

 2.3 Connection Diagram of Test System 12

 2.4 Support Unit used in test configuration and system 13

 2.5 EUT Operation Test Setup 14

 2.6 Measurement Results Explanation Example 14

3 TEST RESULT 15

 3.1 26dB & 99% Occupied Bandwidth Measurement 15

 3.2 Maximum Conducted Output Power Measurement 18

 3.3 Power Spectral Density Measurement 24

 3.4 Unwanted Emissions Measurement 27

 3.5 AC Conducted Emission Measurement 31

 3.6 Frequency Stability Measurement 35

 3.7 Automatically Discontinue Transmission 36

 3.8 Antenna Requirements 37

4 LIST OF MEASURING EQUIPMENT 40

5 UNCERTAINTY OF EVALUATION 41

APPENDIX A. CONDUCTED TEST RESULTS

APPENDIX B. RADIATED TEST RESULTS

APPENDIX C. SETUP PHOTOGRAPHS

APPENDIX D. DUTY CYCLE PLOTS

APPENDIX E. SETUP PHOTOGRAPHS



SUMMARY OF TEST RESULT

Report Section	FCC Rule	Description	Limit	Result	Remark
3.1	2.1049 15.403(i)	26dB & 99% Bandwidth	-	Pass	-
3.2	15.407(a)	Maximum Conducted Output Power	≤ 24 dBm (depend on band)	Pass	-
3.3	15.407(a)	Power Spectral Density	≤ 11 dBm (depend on band)	Pass	-
3.4	15.407(b)	Unwanted Emissions	≤ -17, -27 dBm (depend on band)&15.209(a)	Pass	Under limit 1.25 dB at 5350.08 MHz
3.5	15.207	AC Conducted Emission	15.207(a)	Pass	Under limit 3.90 dB at 0.550 MHz
3.6	15.407(g)	Frequency Stability	Within Operation Band	Pass	-
3.7	15.407(c)	Automatically Discontinue Transmission	Discontinue Transmission	Pass	-
3.8	15.203 & 15.407(a)	Antenna Requirement	N/A	Pass	-



1 General Description

1.1 Applicant

Ignition Design Labs (US) LLC

5F-2., No. 158, Sec. 2, Gongdao 5th Rd., Hsinchu City 30070, Taiwan

1.2 Manufacturer

Ignition Design Labs (US) LLC

5F-2., No. 158, Sec. 2, Gongdao 5th Rd., Hsinchu City 30070, Taiwan

1.3 Product Feature of Equipment Under Test

Product Feature	
Equipment	Advanced Wireless Router
Brand Name	Ignition Design Labs
Model Name	Portal
Marketing Name	Portal
FCC ID	2AFZUSAP102
EUT supports Radios application	WLAN 11a/b/g/n HT20/HT40 WLAN 11ac VHT20/VHT40/VHT80 Bluetooth v4.1 EDR/LE
HW Version	v1.0
SW Version	v1.0
EUT Stage	Identical Prototype

Remark: The above EUT's information was declared by manufacturer. Please refer to the specifications or user's manual for more detailed description.



1.4 Product Specification of Equipment Under Test

Standards-related Product Specification					
Tx/Rx Channel Frequency Range	5260 MHz ~ 5320 MHz 5500 MHz ~ 5700 MHz				
Maximum Output Power <CDD Modes>	MIMO <Ant. Port 1+2+3+4> <5260 MHz ~ 5320 MHz> 802.11a : 18.90 dBm / 0.0776 W 802.11n HT20 : 12.80 dBm / 0.0191 W 802.11n HT40 : 14.80 dBm / 0.0302 W <5500 MHz ~ 5700 MHz> 802.11a : 18.38 dBm / 0.0689 W 802.11n HT20 : 12.03 dBm / 0.0160 W 802.11n HT40 : 14.58 dBm / 0.0287 W				
Maximum Output Power <TXBF Modes>	MIMO <Ant. Port 1+2+3+4> <5260 MHz ~ 5320 MHz> 802.11ac VHT20: 12.85 dBm / 0.0193 W 802.11ac VHT40: 14.81 dBm / 0.0303 W 802.11ac VHT80: 18.05 dBm / 0.0638 W <5500 MHz ~ 5700 MHz> 802.11ac VHT20: 12.48 dBm / 0.0177 W 802.11ac VHT40: 14.67 dBm / 0.0293 W 802.11ac VHT80: 17.15 dBm / 0.0519 W				
99% Occupied Bandwidth <CDD Modes>	802.11a : 17.25 MHz				
99% Occupied Bandwidth <TXBF Modes>	802.11ac VHT20 : 18.90 MHz 802.11ac VHT40 : 37.10 MHz 802.11ac VHT80 : 76.44 MHz				
Type of Modulation	802.11a/n : OFDM (BPSK / QPSK / 16QAM / 64QAM) 802.11ac : OFDM (BPSK / QPSK / 16QAM / 64QAM / 256QAM)				
Antenna Type	PCB Antenna				
Antenna Gain		Ant 1 (dBi)	Ant 2 (dBi)	Ant 3 (dBi)	Ant 4 (dBi)
	5.3G Band	2.38	3.45	4.93	3.47
	5.5G Band	4.34	3.36	5.30	4.58
	5.8G Band	4.26	3.49	4.30	4.67
Antenna Function Description		Ant. 1	Ant. 2	Ant. 3	Ant. 4
	802.11 a/n/ac MIMO	V	V	V	V

1.5 Modification of EUT

No modifications are made to the EUT during all test items.



1.6 Testing Location

Sporton Lab is accredited to ISO 17025 by Taiwan Accreditation Foundation (TAF code : 1190) and the FCC designation No. TW1022 under the FCC 2.948(e) by Mutual Recognition Agreement (MRA) in FCC Test.

Test Site	SPORTON INTERNATIONAL INC.	
Test Site Location	No. 52, Hwa Ya 1 st Rd., Hwa Ya Technology Park, Kwei-Shan District, Tao Yuan City, Taiwan, R.O.C. TEL: +886-3-327-3456 FAX: +886-3-328-4978	
Test Site No.	Sporton Site No.	
	TH02-HY	CO05-HY

Note: The test site complies with ANSI C63.4 2014 requirement.

Test Site	SPORTON INTERNATIONAL INC.	
Test Site Location	No.58, Aly. 75, Ln. 564, Wenhua 3rd Rd. Guishan Dist, Taoyuan City, Taiwan (R.O.C.) TEL: +886-3-327-0868 FAX: +886-3-327-0855	
Test Site No.	Sporton Site No.	
	03CH10-HY	

Note: The test site complies with ANSI C63.4 2014 requirement.



1.7 Applicable Standards

According to the specifications of the manufacturer, the EUT must comply with the requirements of the following standards:

- ♦ FCC Part 15 Subpart E
- ♦ FCC KDB 789033 D02 General UNII Test Procedures New Rules v01r02
- ♦ FCC KDB 662911 D01 Multiple Transmitter Output v02r01.
- ♦ FCC KDB 644545 D03 Guidance for IEEE 802 11ac New Rules v01
- ♦ ANSI C63.10-2013

Remark: All test items were verified and recorded according to the standards and without any deviation during the test.



2 Test Configuration of Equipment Under Test

The EUT has been associated with peripherals and configuration operated in a manner tended to maximize its emission characteristics in a typical application. Frequency range investigated: conducted emission (150 kHz to 30 MHz) and radiated emission (9 kHz to the 10th harmonic of the highest fundamental frequency or to 40 GHz, whichever is lower). For radiated measurement, pre-scanned in three orthogonal panels, X, Y, Z. The worst cases (X plane) were recorded in this report.

Based on the worst configuration found above, the RF power setting is set individually to meet FCC compliance limit for the final conducted and radiated tests shown in section 2.2.

2.1 Carrier Frequency and Channel

Frequency Band	Channel	Freq. (MHz)	Channel	Freq. (MHz)
5250-5350 MHz Band 2 (U-NII-2A)	52	5260	60	5300
	54	5270	62	5310
	56	5280	64	5320
	58	5290		

Frequency Band	Channel	Freq. (MHz)	Channel	Freq. (MHz)
5470-5600 MHz and 5650-5725 MHz Band 3 (U-NII-2C)	100	5500	112	5560
	102	5510	116	5580
	104	5520	132	5660
	106	5530	134	5670
	108	5540	136	5680
	110	5550	140	5700

Frequency Band	Channel	Freq. (MHz)	Channel	Freq. (MHz)
Straddle Channel	144	5720	142	5710
	138	5690		

Note: The above Frequency and Channel in boldface were 802.11n HT40.



2.2 Test Mode

Final test mode of conducted test items and radiated spurious emissions are considering the modulation and worse data rates as below table.

Modulation	Data Rate
802.11a	6 Mbps
802.11n HT20	MCS0
802.11n HT40	MCS0
802.11ac VHT20	MCS0
802.11ac VHT40	MCS0
802.11ac VHT80	MCS0

	MIMO mode	Power	Conducted	RSE
802.11a	CDD	Test	Test	Test
802.11n HT20/HT40	CDD	Test	Covered by 802.11ac	Covered by 802.11ac
802.11ac VHT20/VHT40/VHT80	TXBF	Test	Test	Test

Test Cases	
AC Conducted Emission	Mode 1 : Bluetooth Link + WLAN (5GHz) Link 802.11ac VHT80 MCS0 + LAN Link + USB Link + Adapter 1



Ch. #		Band II : 5250-5350 MHz	Band II : 5250-5350 MHz	Band II : 5250-5350 MHz
		802.11a	802.11n HT20	802.11n HT40
L	Low	52	52	54
M	Middle	60	60	-
H	High	64	64	62
Straddle		-	-	-

Ch. #		Band II : 5250-5350 MHz	Band II : 5250-5350 MHz	Band II : 5250-5350 MHz
		802.11ac VHT20	802.11ac VHT40	802.11ac VHT80
L	Low	52	54	-
M	Middle	60	-	58
H	High	64	62	-
Straddle		-	-	-

Ch. #		Band III : 5470-5600 MHz and 5650-5725MHz	Band III : 5470-5600 MHz and 5650-5725MHz	Band III : 5470-5600 MHz and 5650-5725MHz
		802.11a	802.11n HT20	802.11n HT40
L	Low	100	100	102
M	Middle	116	116	110
H	High	140	140	134
Straddle		144	144	142

Ch. #		Band III : 5470-5600 MHz and 5650-5725MHz	Band III : 5470-5600 MHz and 5650-5725MHz	Band III : 5470-5600 MHz and 5650-5725MHz
		802.11ac VHT20	802.11ac VHT40	802.11ac VHT80
L	Low	100	102	-
M	Middle	116	110	106
H	High	140	134	-
Straddle		144	142	138

2.3 Connection Diagram of Test System

<WLAN Tx CDD Mode>

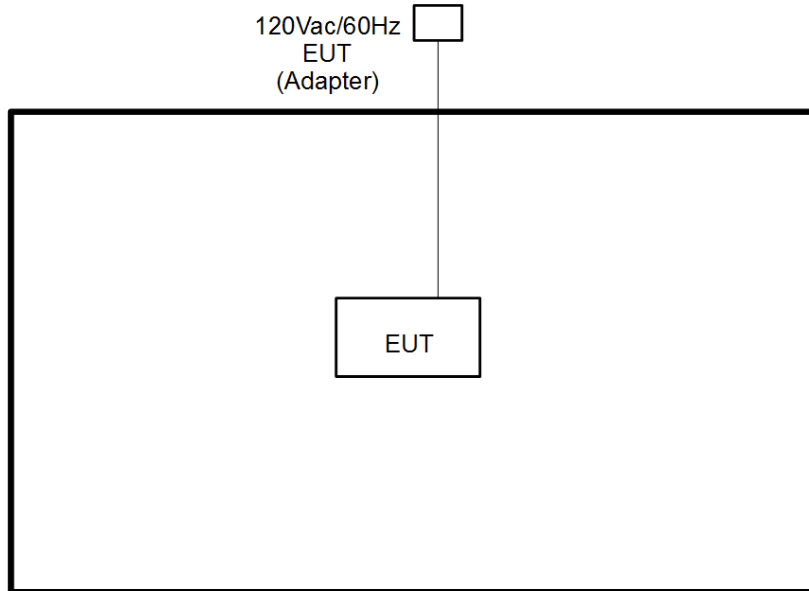

<WLAN Tx TXBF Mode>

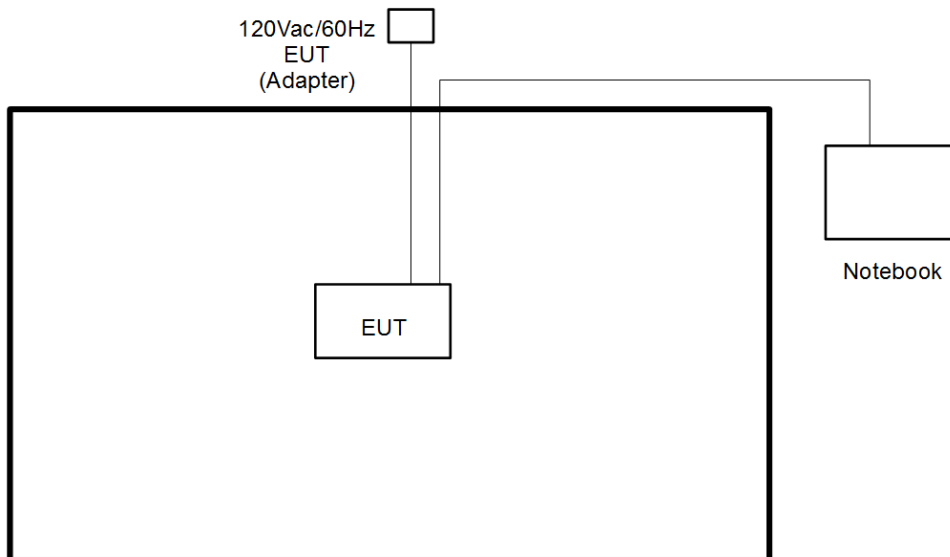

<AC Conducted Emission Mode>

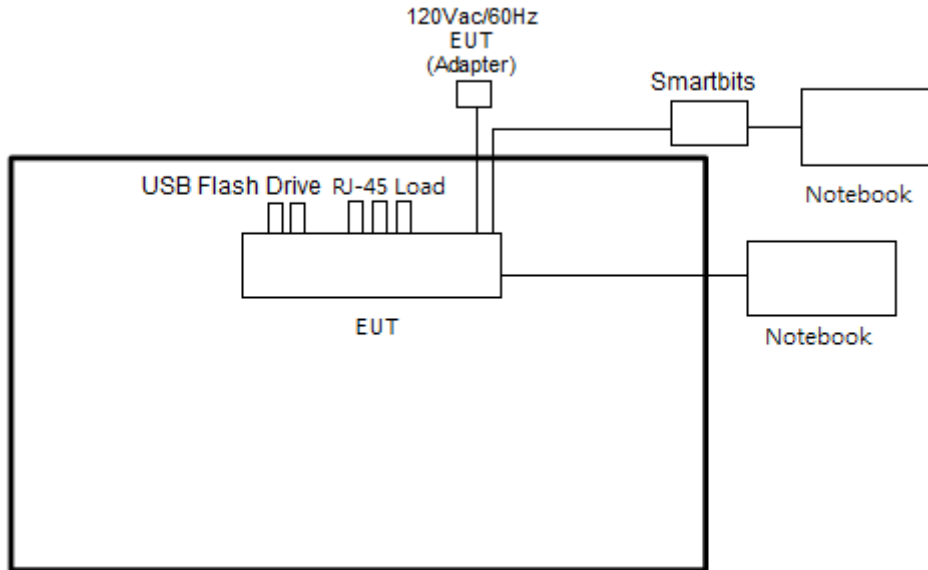

2.4 Support Unit used in test configuration and system

Item	Equipment	Trade Name	Model Name	FCC ID	Data Cable	Power Cord
1.	Notebook	DELL	Latitude E6320	FCC DoC/ Contains FCC ID: QDS-BRCM1054	N/A	AC I/P: Unshielded, 1.2 m DC O/P: Shielded, 1.8 m
2.	Notebook	DELL	P20G	FCC DoC/ Contains FCC ID: QDS-BRCM1051	N/A	AC I/P: Unshielded, 1.2 m DC O/P: Shielded, 1.8 m
3.	USB flash drive	Transcend	JetFlash 700	FCC DoC	N/A	N/A
4.	Smartbits	Spirent	SMB600B	N/A	Shielded, 1.5 m	Unshielded, 1.8 m



2.5 EUT Operation Test Setup

For CDD modes, programmed RF utility, “QRCT” installed in the notebook make the EUT provide functions like channel selection and power level for continuous transmitting and receiving signals.

For TXBF modes, Software “LANTEST.EXE” v2.0.0.2 installed in the notebook and command lines make the EUT provide functions like channel selection and power level for continuous transmitting and receiving signals.

2.6 Measurement Results Explanation Example

For all conducted test items:

The offset level is set in the spectrum analyzer to compensate the RF cable loss and attenuator factor between EUT conducted output port and spectrum analyzer. With the offset compensation, the spectrum analyzer reading level is exactly the EUT RF output level.

Example :

The spectrum analyzer offset is derived from RF cable loss and attenuator factor.

Offset = RF cable loss + attenuator factor.

Following shows an offset computation example with cable loss 4.2 dB and 10dB attenuator.

$$\begin{aligned} \text{Offset(dB)} &= \text{RF cable loss(dB)} + \text{attenuator factor(dB)}. \\ &= 4.2 + 10 = 14.2 \text{ (dB)} \end{aligned}$$

3 Test Result

3.1 26dB & 99% Occupied Bandwidth Measurement

3.1.1 Description of 26dB & 99% Occupied Bandwidth

This section is for reporting purpose only.

There is no restriction limits for bandwidth.

For Straddle Channel, U-NII procedures were applied for operations in the frequency band in accordance with FCC KDB 644545 D03.

3.1.2 Measuring Instruments

The measuring equipment is listed in the section 4 of this test report.

3.1.3 Test Procedures

1. The testing follows FCC KDB 789033 D02 General UNII Test Procedures New Rules v01r02. Section C) Emission bandwidth
2. Set RBW = approximately 1% of the emission bandwidth.
3. Set the VBW > RBW.
4. Detector = Peak.
5. Trace mode = max hold
6. Measure the maximum width of the emission that is 26 dB down from the peak of the emission. Compare this with the RBW setting of the analyzer. Readjust RBW and repeat measurement as needed until the RBW/EBW ratio is approximately 1%.
7. For 99% Bandwidth Measurement, the spectrum analyzer's resolution bandwidth (RBW) is set 1MHz and set the Video bandwidth (VBW) $\geq 3 * RBW$.
8. Measure and record the results in the test report.

3.1.4 Test Setup

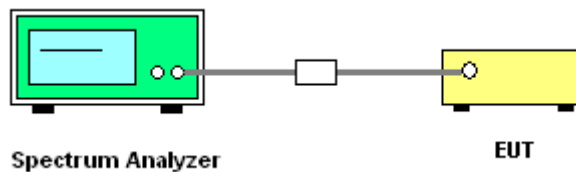



3.1.5 Test Result of 26dB & 99% Occupied Bandwidth

Please refer to Appendix A.

<CDD Modes>

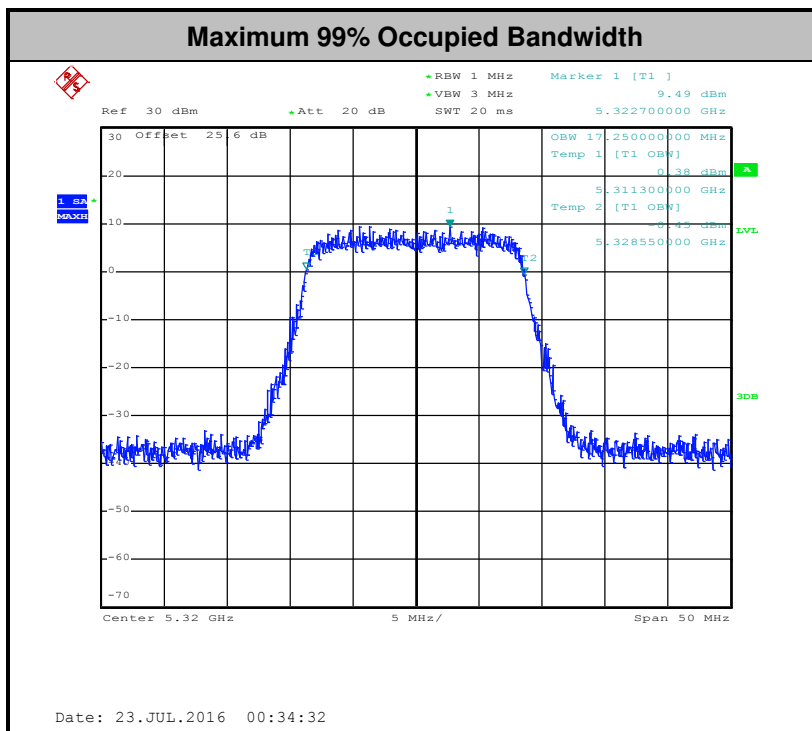
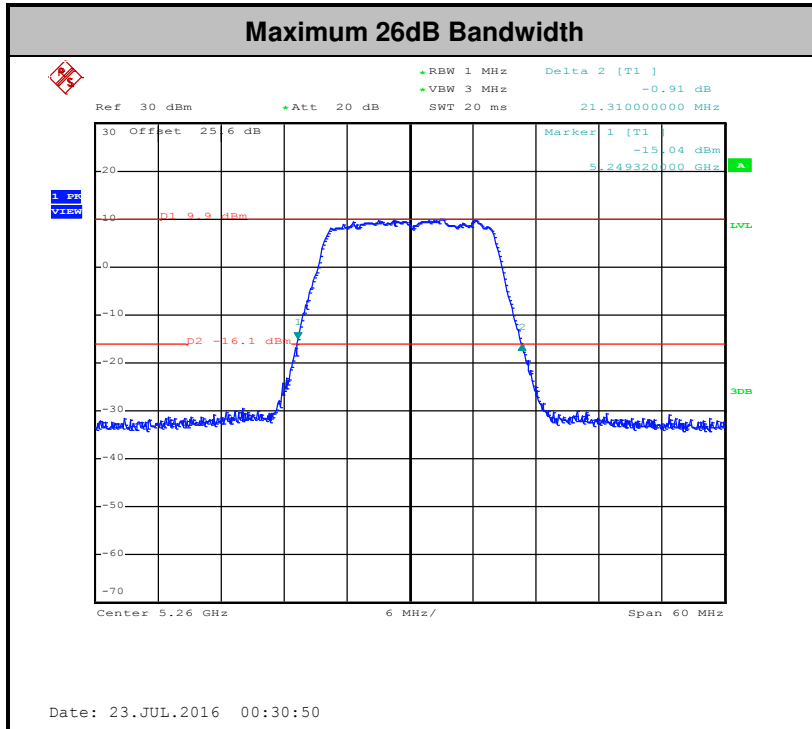

Note: The occupied channel bandwidth is maintained within the band of operation for all of the modulations.



<TXBF Modes>

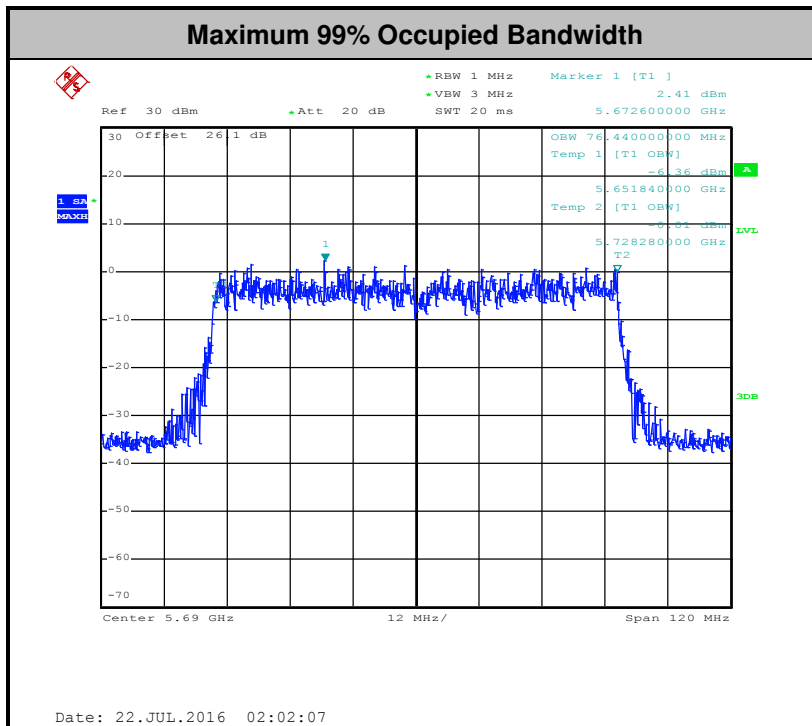
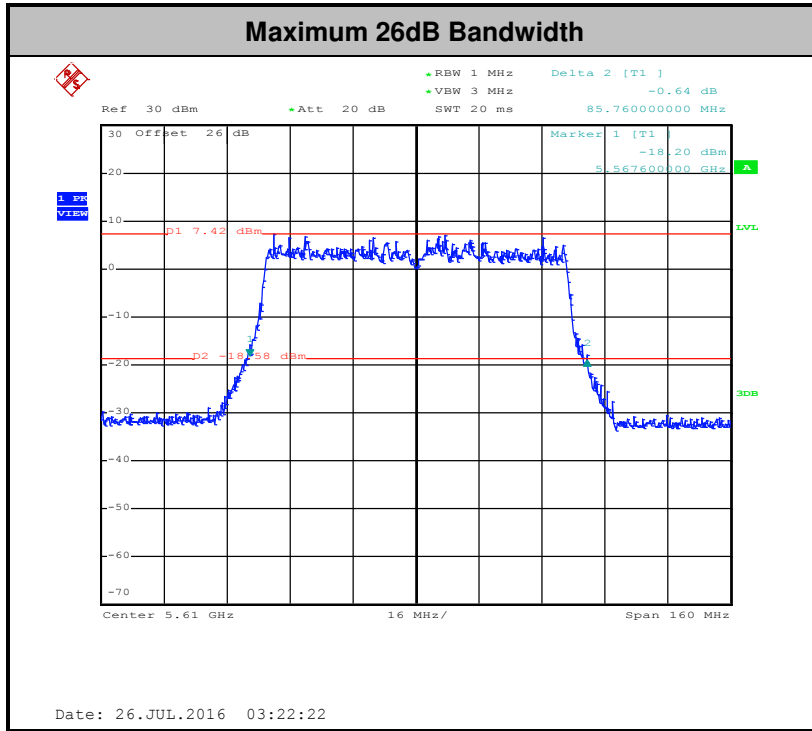

Note: The occupied channel bandwidth is maintained within the band of operation for all of the modulations.



3.2 Maximum Conducted Output Power Measurement

3.2.1 Limit of Maximum Conducted Output Power

For the 5.25–5.35 GHz and 5.47–5.725 GHz bands, the maximum conducted output power over the frequency bands of operation shall not exceed the lesser of 250 mW or $11 \text{ dBm} + 10 \log B$, where B is the 26 dB emission bandwidth in megahertz.

For the band 5.725–5.85 GHz, the maximum conducted output power over the frequency band of operation shall not exceed 1 W.

For Straddle Channel, U-NII procedures and limits were applied for operations in the frequency band in accordance with FCC KDB 644545 D03.

If transmitting antennas of directional gain greater than 6 dBi are used, the peak output power shall be reduced by the amount in dB that the directional gain of the antenna exceeds 6 dBi.

Note that U-NII-2 band, devices with a maximum e.i.r.p. greater than 500 mW shall implement TPC in order to have the capability to operate at least 6 dB below the maximum permitted e.i.r.p. of 1 W.

3.2.2 Measuring Instruments

The measuring equipment is listed in the section 4 of this test report.

3.2.3 Test Procedures

CDD modes

The testing follows Method PM of FCC KDB 789033 D02 General UNII Test Procedures New Rules v01r02 for CDD modes.

Method PM (Measurement using an RF average power meter):

1. Measurement is performed using a wideband RF power meter.
2. The EUT is configured to transmit continuously with a consistent duty cycle at its maximum power control level.
3. Measure the average power of the transmitter, and the average power is corrected with duty factor, $10 \log(1/x)$, where x is the duty cycle.

TXBF modes

The testing follows Method PM-G of FCC KDB 789033 D02 General UNII Test Procedures New Rules v01r02 for TXBF modes.

Method PM-G (Measurement using a gated RF average power meter):

1. Measurement is performed using a wideband RF power meter.
2. The EUT is configured to transmit at its maximum power control level.
3. Measure the average power of the transmitter
4. Since the measurement is made only during the ON time of the transmitter, no duty cycle correction factor is required.

For straddle channel, the testing follows Method SA-3 (RMS detection with max hold) of FCC KDB 789033 D02 General UNII Test Procedures New Rules v01r02.

Compute power by integrating the spectrum across the 99% occupied bandwidth of the signal using the instrument's band power measurement function.

3.2.4 Test Setup

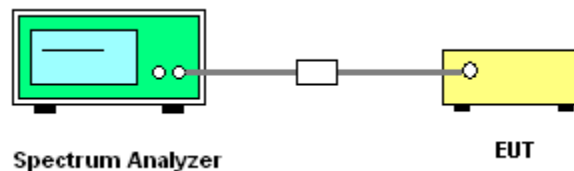



3.2.5 Test Result of Maximum Conducted Output Power

Please refer to Appendix A.

CDD modes

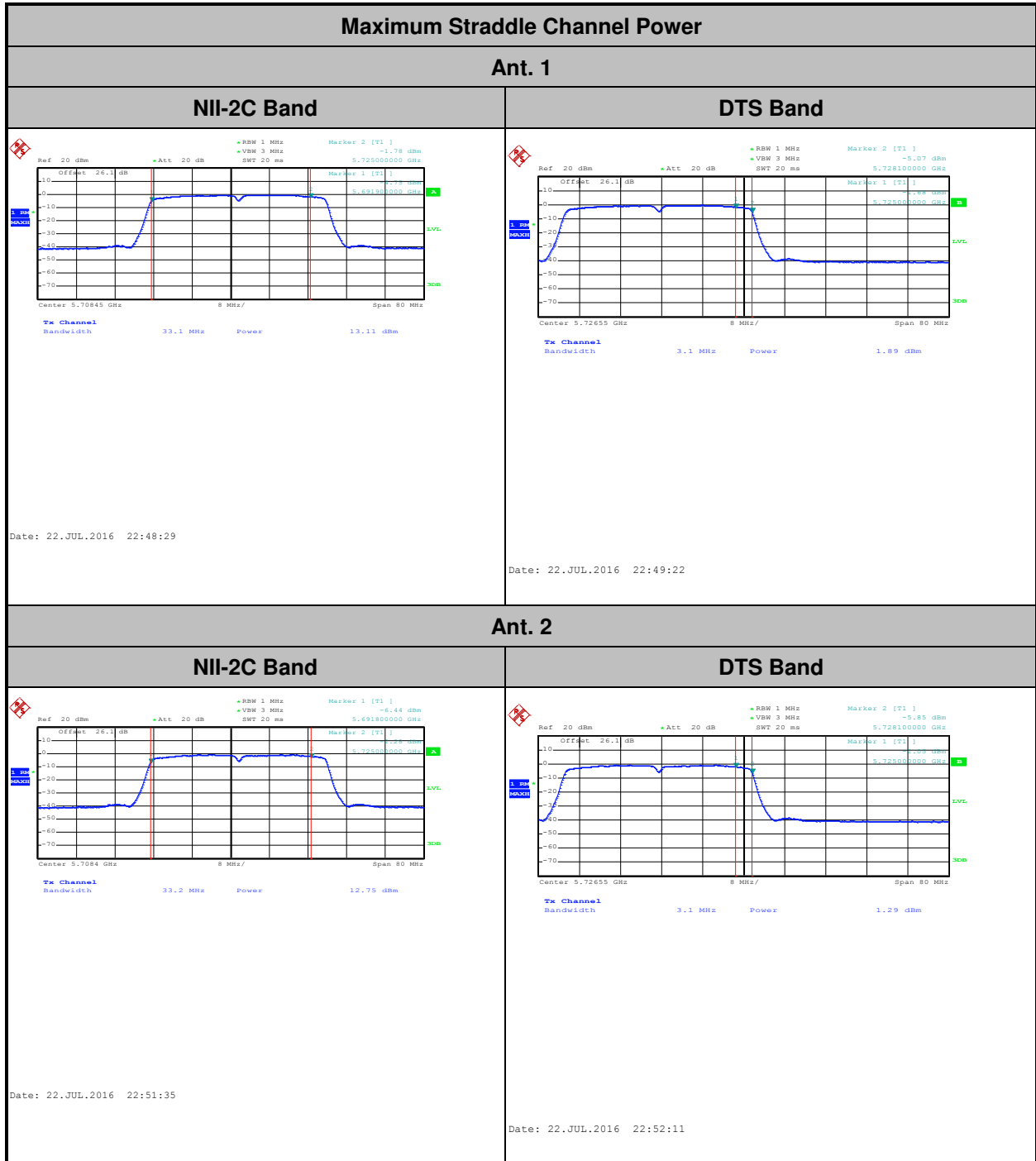



Maximum Straddle Channel Power

Ant. 3

NII-2C Band

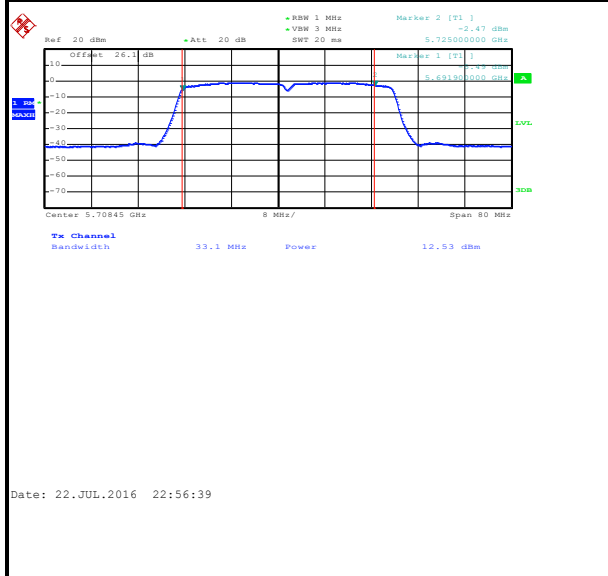

DTS Band

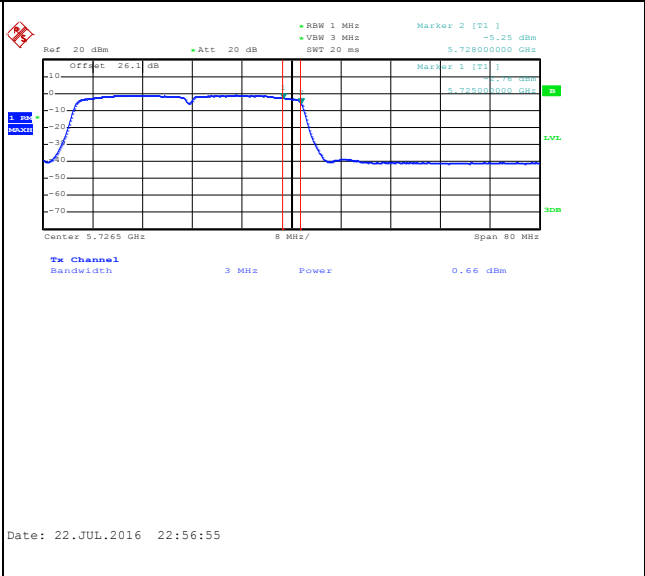

Ant. 4

NII-2C Band

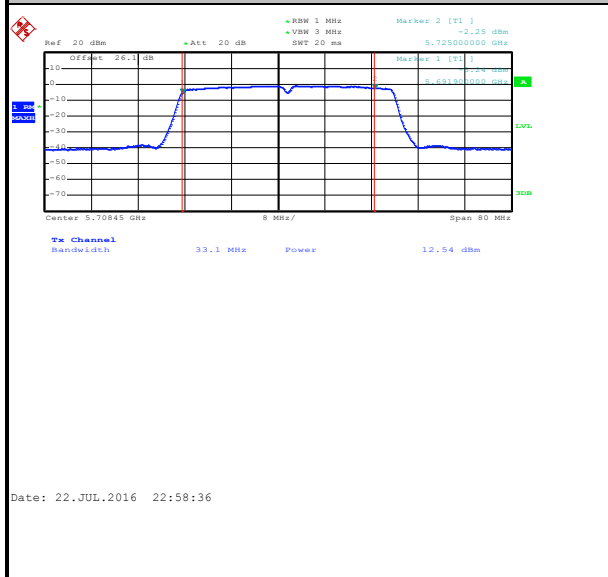

DTS Band

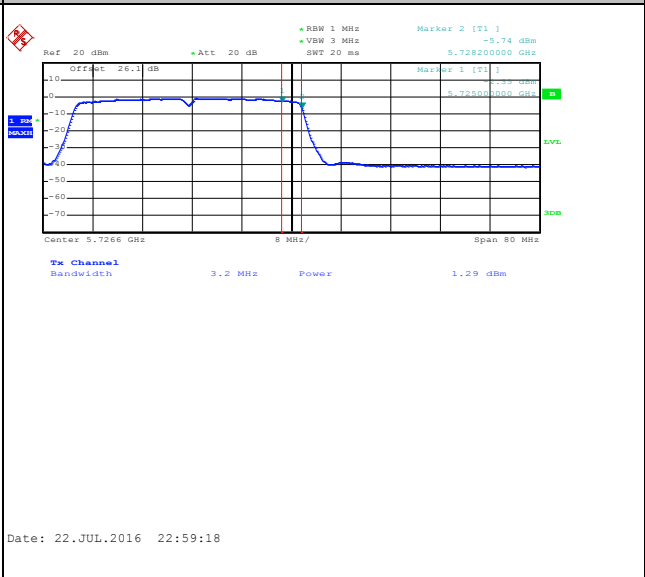



TXBF modes

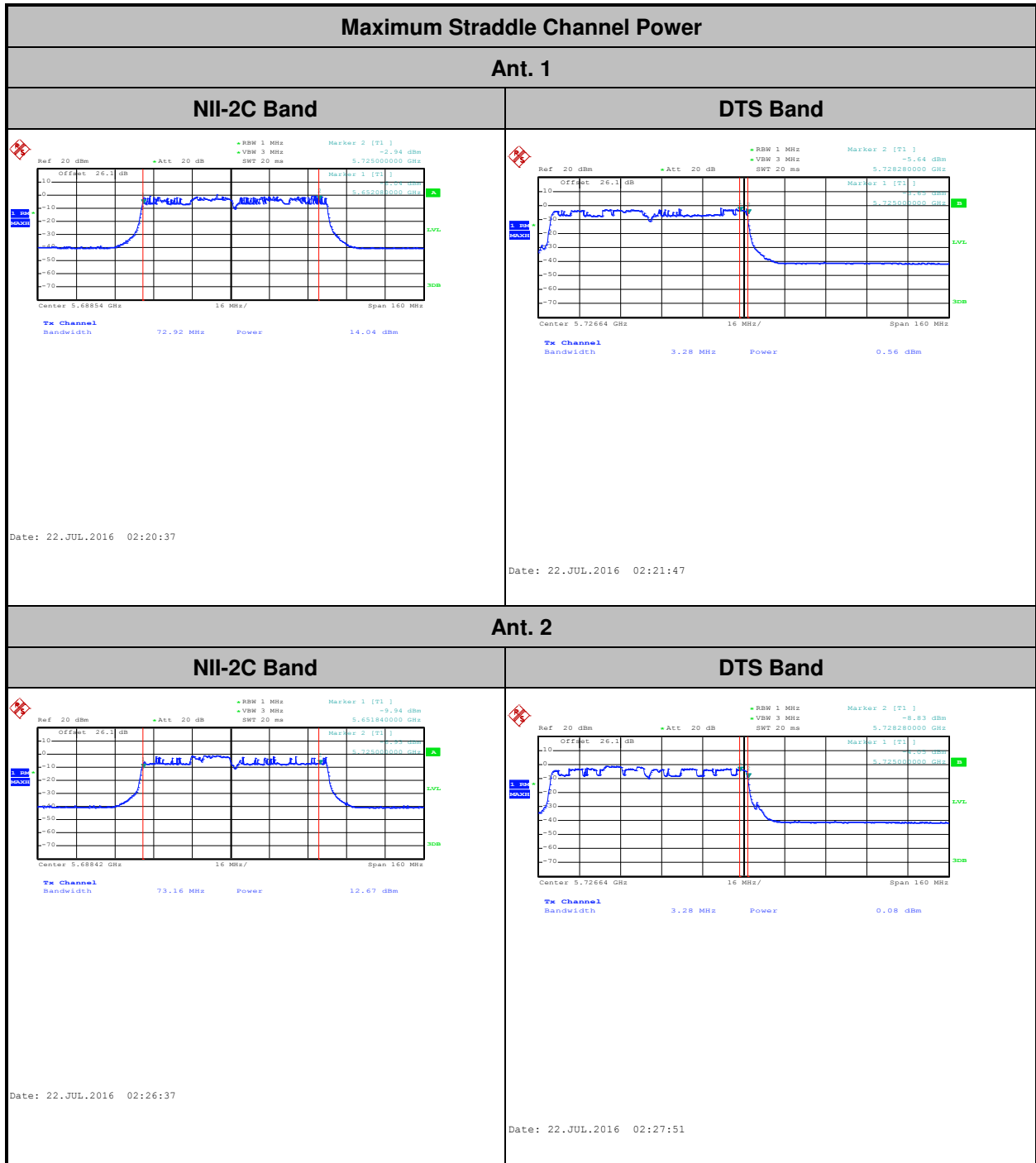

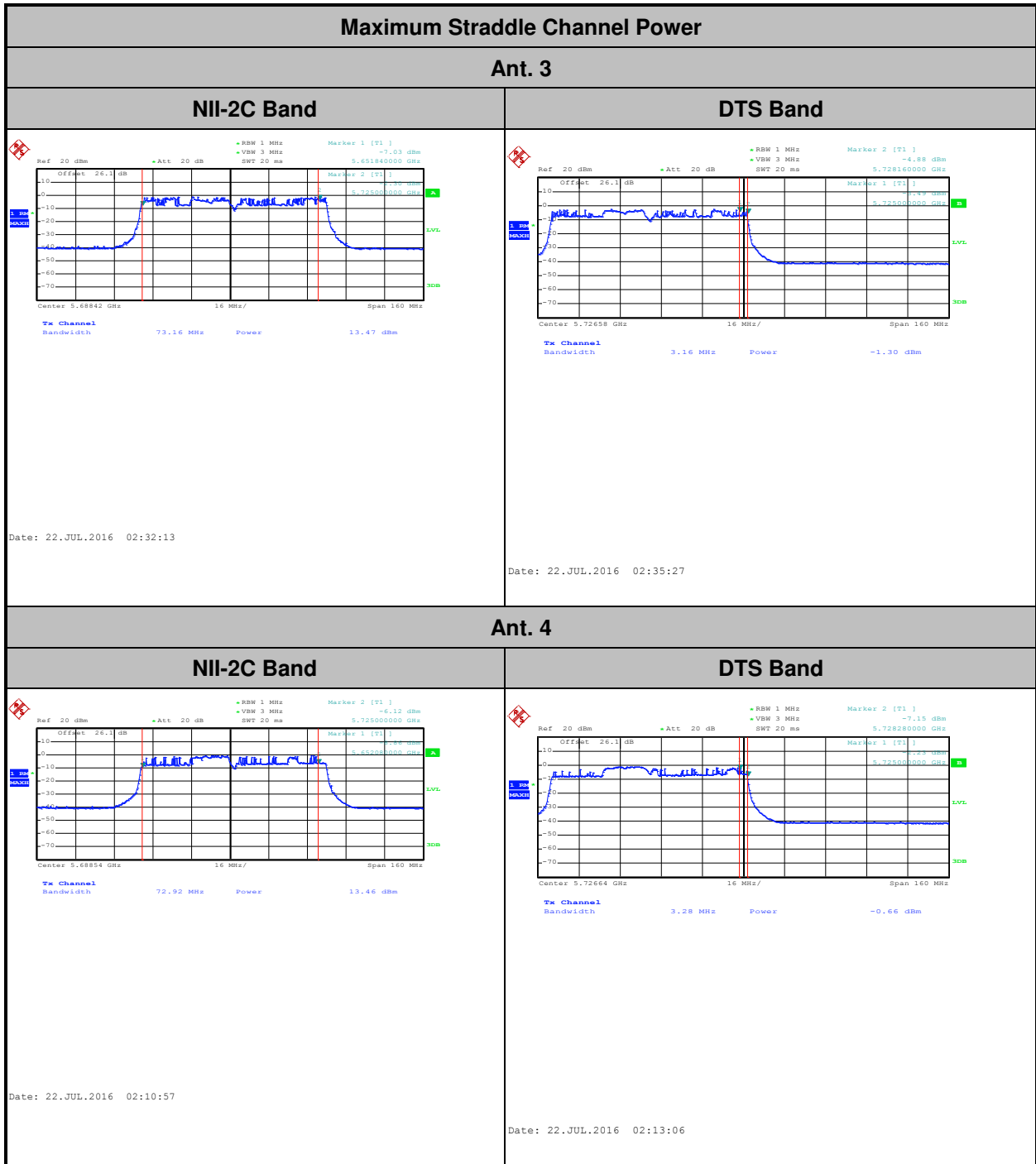



3.3 Power Spectral Density Measurement

3.3.1 Limit of Power Spectral Density

For the 5.25–5.35 GHz and 5.47–5.725 GHz bands, the maximum power spectral density shall not exceed 11 dBm in any 1 megahertz band.

For the band 5.725–5.85 GHz, the maximum power spectral density shall not exceed 30 dBm in any 500-kHz band.

For Straddle Channel, U-NII procedures and limits were applied for operations in the frequency band in accordance with FCC KDB 644545 D03.

If transmitting antennas of directional gain greater than 6 dBi are used, the peak output power shall be reduced by the amount in dB that the directional gain of the antenna exceeds 6 dBi.

3.3.2 Measuring Instruments

The measuring equipment is listed in the section 4 of this test report.

3.3.3 Test Procedures

The testing follows FCC KDB 789033 D02 General UNII Test Procedures New Rules v01r02. Section F) Maximum power spectral density.

CDD modes

Method SA-2

(trace averaging across on and off times of the EUT transmissions, followed by duty cycle correction).

- Measure the duty cycle.
- Set span to encompass the entire emission bandwidth (EBW) of the signal.
- Set RBW = 1 MHz.
- Set VBW \geq 3 MHz.
- Number of points in sweep \geq 2 Span / RBW.
- Sweep time = auto.
- Detector = RMS
- Trace average at least 100 traces in power averaging mode.
- Add $10 \log(1/x)$, where x is the duty cycle, to the measured power in order to compute the average power during the actual transmission times. For example, add $10 \log(1/0.25) = 6$ dB if the duty cycle is 25 percent.

TXBF modes**# Method SA-3 #**

(power averaging (rms) detection with max hold):

- Set span to encompass the entire emission bandwidth (EBW) of the signal.
 - Set RBW = 1 MHz.
 - Set VBW \geq 3 MHz
 - Number of points in sweep \geq 2 Span / RBW.
 - Sweep time \leq (number of points in sweep) \times T, when duty cycle is less than 98 percent where T is the minimum transmission duration over which the transmitter is on and is transmitting at its maximum power control level for the tested mode of operation.
 - Detector = power averaging (rms).
 - Trace mode = max hold.
 - Allow max hold to run for at least 60 seconds, or longer as needed to allow the trace to stabilize.
1. The RF output of EUT was connected to the spectrum analyzer by a low loss cable.
 2. Each plot has already offset with cable loss, and attenuator loss. Measure the PPSD and record it.
 3. For MIMO mode, calculation method follows FCC KDB 662911 D01 Multiple Transmitter Output v02r01.

Method (a): Measure and sum the spectra across the outputs.

The total final Power Spectral Density is from a device with all transmitter outputs. The spectrum measurements of the individual outputs are all performed with the same span and number of points, the spectrum value in the first spectral bin of output 1 is summed with that in the first spectral bin of output 2, output 3 and output 4 to obtain the value for the first frequency bin of the summed spectrum.

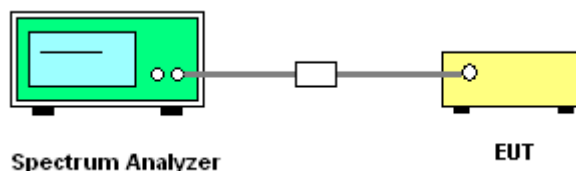
3.3.4 Test Setup



3.3.5 Test Result of Power Spectral Density

Please refer to Appendix A.

<CDD Modes>

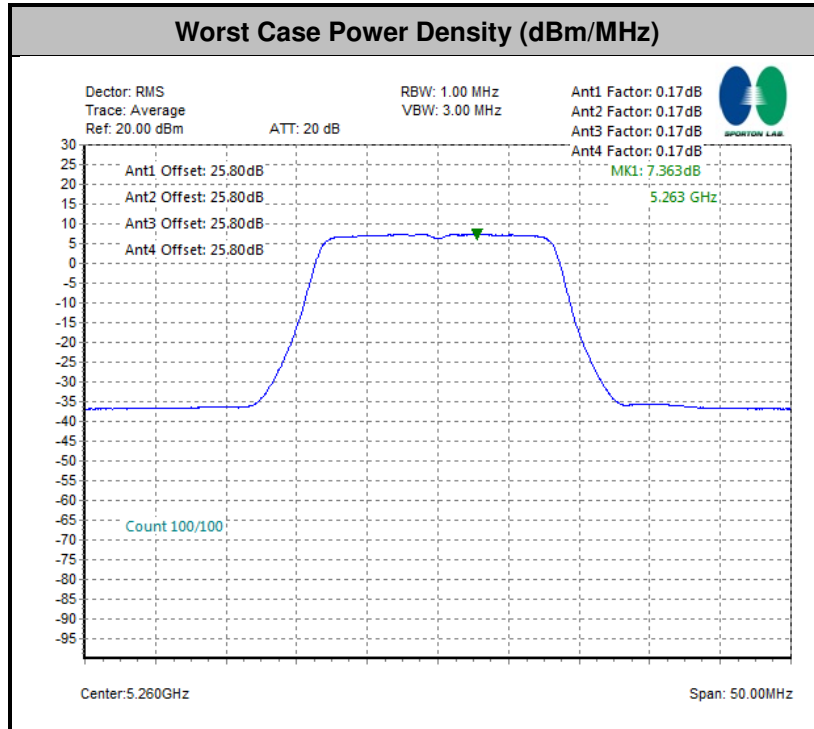

Note: Average Power Density (dB) = Measured value+ Duty Factor

<TXBF Modes>

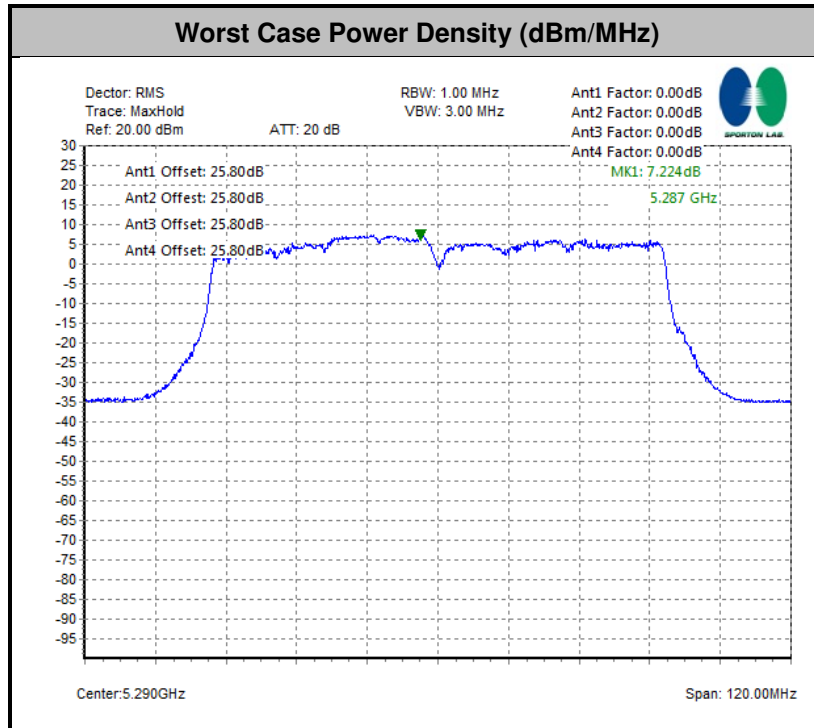

Note: Average Power Density (dB) = Measured value+ Duty Factor



3.4 Unwanted Emissions Measurement

This section as specified in FCC Part 15.407(b) is to measure unwanted emissions through radiated measurement for band edge spurious emissions and out of band emissions measurement. The unwanted emissions shall comply with 15.407(b)(1) to (6), and restricted bands per FCC Part15.205.

3.4.1 Limit of Unwanted Emissions

- (1) For transmitters operating in the 5250-5350 MHz band: all emissions outside of the 5150-5350 MHz band shall not exceed an EIRP of -27 dBm/MHz. Devices operating in the 5250-5350 MHz band that generate emissions in the 5150-5250 MHz band must meet all applicable technical requirements for operation in the 5150-5250 MHz band (including indoor use) or alternatively meet an out-of-band emission EIRP limit of -27 dBm/MHz in the 5150-5250 MHz band.
For transmitters operating in the 5470-5600 MHz and 5650-5725MHz band: all emissions outside of the 5470-5600 MHz and 5650-5725MHz band shall not exceed an EIRP of -27 dBm/MHz.
- (2) Unwanted spurious emissions fallen in restricted bands per FCC Part15.205 shall comply with the general field strength limits set forth in § 15.209 as below table,

Frequency (MHz)	Field Strength (microvolts/meter)	Measurement Distance (meters)
0.009 – 0.490	2400/F(kHz)	300
0.490 – 1.705	24000/F(kHz)	30
1.705 – 30.0	30	30
30 – 88	100	3
88 – 216	150	3
216 - 960	200	3
Above 960	500	3

Note: The following formula is used to convert the EIRP to field strength.

$$E = \frac{1000000\sqrt{30P}}{3} \mu\text{V/m, where P is the eirp (Watts)}$$

EIRP (dBm)	Field Strength at 3m (dBµV/m)
-17	78.3
- 27	68.3

- (3) KDB789033 D02 v01r02 G)2)c) As specified in 15.407(b), emissions above 1000 MHz that are outside of the restricted bands are subject to a peak emission limit of -27 dBm/MHz (or -17 dBm/MHz as specified in 15.407(b)(4)). However, an out-of-band emission that complies with both the average and peak limits of 15.209 is not required to satisfy the -27 dBm/MHz or -17 dBm/MHz peak emission limit.



3.4.2 Measuring Instruments

The measuring equipment is listed in the section 4 of this test report.

3.4.3 Test Procedures

1. The testing follows FCC KDB 789033 D02 General UNII Test Procedures New Rules v01r02. Section G) Unwanted emissions measurement.
 - (1) Procedure for Unwanted Emissions Measurements Below 1000MHz
 - RBW = 120 kHz
 - VBW = 300 kHz
 - Detector = Peak
 - Trace mode = max hold
 - (2) Procedure for Peak Unwanted Emissions Measurements Above 1000 MHz
 - RBW = 1 MHz
 - VBW \geq 3 MHz
 - Detector = Peak
 - Sweep time = auto
 - Trace mode = max hold
 - (3) Procedures for Average Unwanted Emissions Measurements Above 1000MHz
 - RBW = 1 MHz
 - VBW = 10 Hz, when duty cycle is no less than 98 percent.
 - VBW \geq 1/T, when duty cycle is less than 98 percent where T is the minimum transmission duration over which the transmitter is on and is transmitting at its maximum power control level for the tested mode of operation.
2. The EUT was placed on a turntable with 0.8 meter for frequency below 1GHz and 1.5 meter for frequency above 1GHz respectively above ground.
3. The EUT was set 3 meters from the interference receiving antenna which was mounted on the top of a variable height antenna tower.
4. The antenna is a broadband antenna and its height is adjusted between one meter and four meters above ground to find the maximum value of the field strength for both horizontal polarization and vertical polarization of the antenna.
5. For each suspected emission, the EUT was arranged to its worst case and then adjust the antenna tower (from 1 m to 4 m) and turntable (from 0 degree to 360 degrees) to find the maximum reading.
6. For testing below 1GHz, if the emission level of the EUT in peak mode was 3 dB lower than the limit specified, then peak values of EUT will be reported, otherwise, the emissions will be repeated one by one using the CISPR quasi-peak method and reported.

- For testing above 1GHz, the emission level of the EUT in peak mode was 20dB lower than average limit (that means the emission level in average mode also complies with the limit in average mode), then peak values of EUT will be reported, otherwise, the emissions will be measured in average mode again and reported.

3.4.4 Test Setup

For radiated emissions below 30MHz

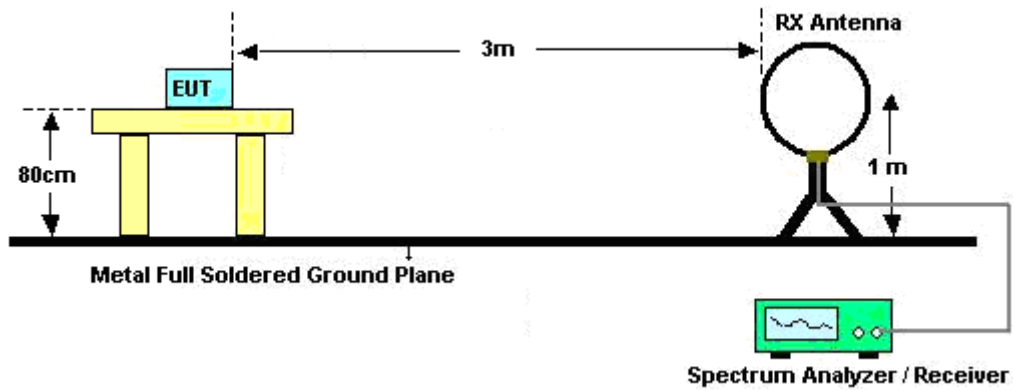

For radiated emissions from 30MHz to 1GHz

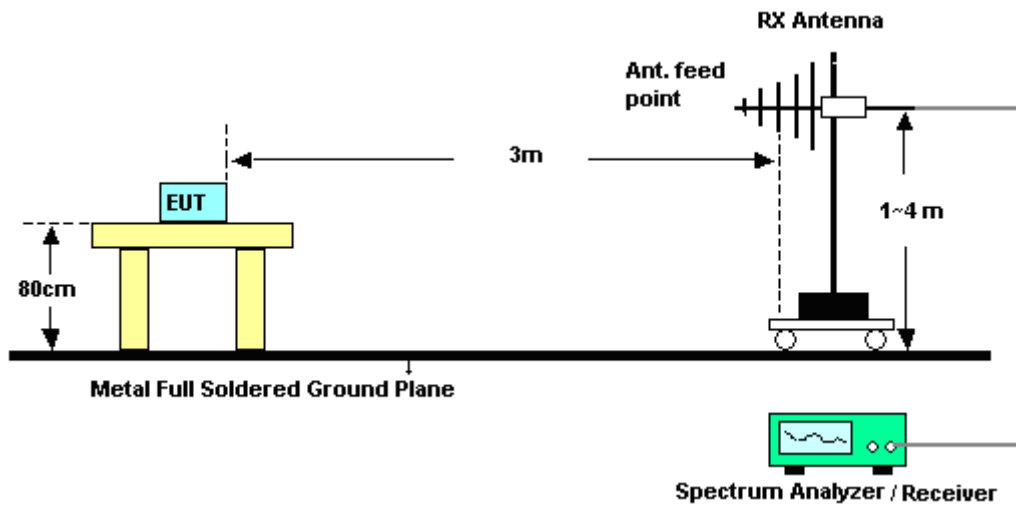

For radiated emissions above 1GHz

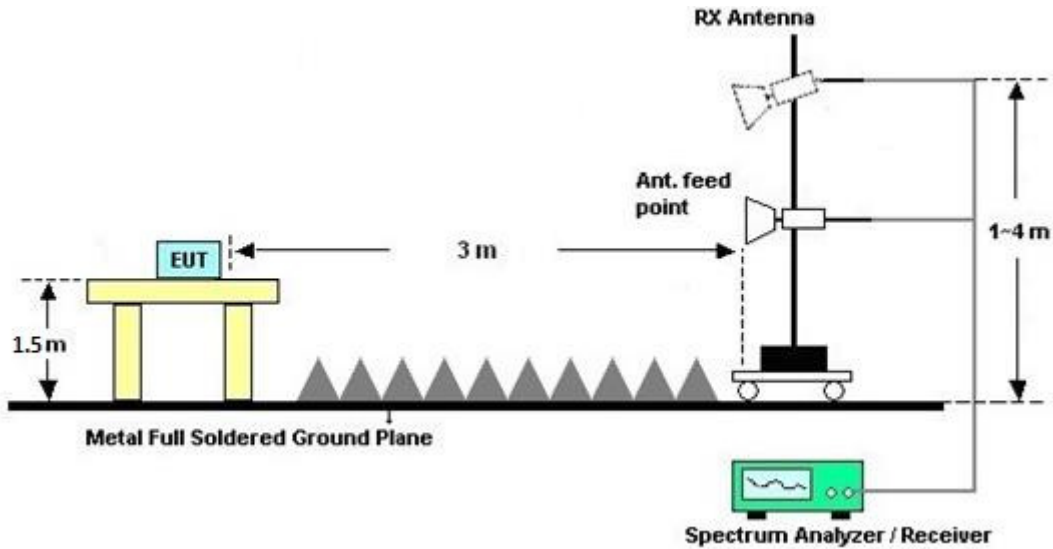

3.4.5 Test Results of Radiated Emissions (9 kHz ~ 30 MHz)

The low frequency, which started from 9 kHz to 30MHz, was pre-scanned and the result which was 20dB lower than the limit line per 15.31(o) was not reported.

3.4.6 Test Result of Radiated Band Edges

Please refer to Appendix B and C.

3.4.7 Duty Cycle

Please refer to Appendix D.

3.4.8 Test Result of Unwanted Radiated Emission (30MHz ~ 10th Harmonic)

Please refer to Appendix B and C.



3.5 AC Conducted Emission Measurement

3.5.1 Limit of AC Conducted Emission

For equipment that is designed to be connected to the public utility (AC) power line, the radio frequency voltage that is conducted back onto the AC power line on any frequency or frequencies within the band 150 kHz to 30 MHz shall not exceed the limits in the following table.

Frequency of emission (MHz)	Conducted limit (dBµV)	
	Quasi-peak	Average
0.15-0.5	66 to 56*	56 to 46*
0.5-5	56	46
5-30	60	50

*Decreases with the logarithm of the frequency.

3.5.2 Measuring Instruments

The measuring equipment is listed in the section 4 of this test report.

3.5.3 Test Procedures

1. The EUT was placed 0.4 meter from the conducting wall of the shielding room was kept at least 80 centimeters from any other grounded conducting surface.
2. Connect EUT to the power mains through a line impedance stabilization network (LISN).
3. All the support units are connecting to the other LISN.
4. The LISN provides 50 ohm coupling impedance for the measuring instrument.
5. The FCC states that a 50 ohm, 50 microhenry LISN should be used.
6. Both sides of AC line were checked for maximum conducted interference.
7. The frequency range from 150 kHz to 30 MHz was searched.
8. Set the test-receiver system to Peak Detect Function and specified bandwidth with Maximum Hold Mode.

3.5.4 Test Setup

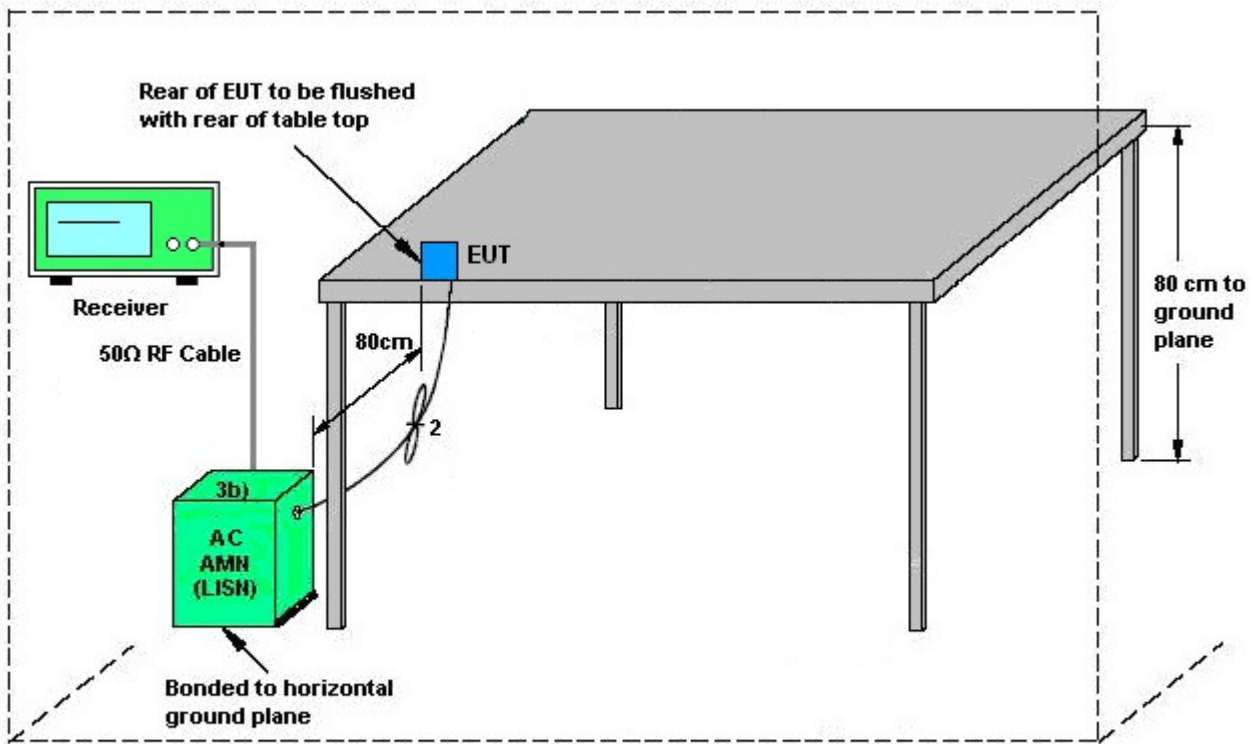

AMN = Artificial mains network (LISN)
AE = Associated equipment
EUT = Equipment under test
ISN = Impedance stabilization network



3.5.5 Test Result of AC Conducted Emission

Test Mode :	Mode 1	Temperature :	22~23°C
Test Engineer :	Arthur Hsieh	Relative Humidity :	50~51%
Test Voltage :	120Vac / 60Hz	Phase :	Line
Function Type :	Bluetooth Link + WLAN (5GHz) Link 802.11ac VHT80 MCS0 + LAN Link + USB Link + Adapter 1		

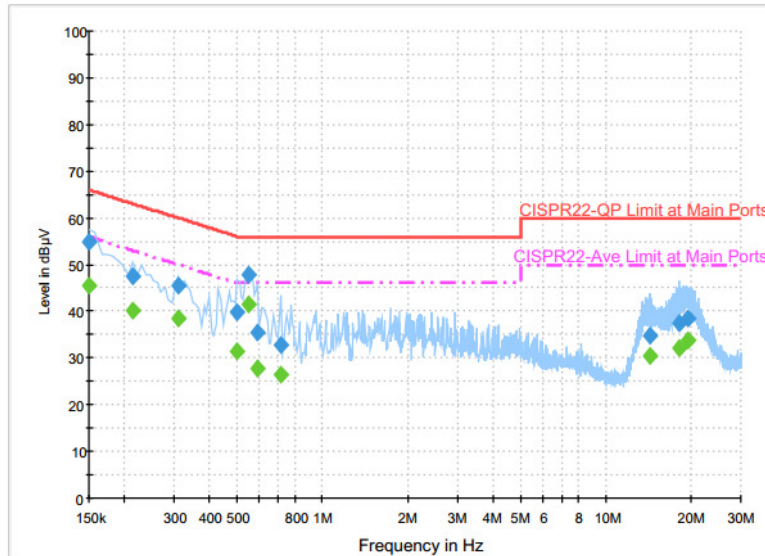

Final Result : QuasiPeak

Frequency (MHz)	QuasiPeak (dBµV)	Filter	Line	Corr. (dB)	Margin (dB)	Limit (dBµV)
0.150000	54.7	Off	L1	19.6	11.3	66.0
0.214000	47.5	Off	L1	19.6	15.5	63.0
0.310000	45.6	Off	L1	19.6	14.4	60.0
0.502000	39.7	Off	L1	19.6	16.3	56.0
0.550000	47.7	Off	L1	19.6	8.3	56.0
0.590000	35.6	Off	L1	19.6	20.4	56.0
0.710000	32.7	Off	L1	19.6	23.3	56.0
14.286000	34.9	Off	L1	20.4	25.1	60.0
18.094000	37.4	Off	L1	20.6	22.6	60.0
19.574000	38.3	Off	L1	20.7	21.7	60.0

Final Result : Average

Frequency (MHz)	Average (dBµV)	Filter	Line	Corr. (dB)	Margin (dB)	Limit (dBµV)
0.150000	45.6	Off	L1	19.6	10.4	56.0
0.214000	40.3	Off	L1	19.6	12.7	53.0
0.310000	38.6	Off	L1	19.6	11.4	50.0
0.502000	31.4	Off	L1	19.6	14.6	46.0
0.550000	41.5	Off	L1	19.6	4.5	46.0
0.590000	27.8	Off	L1	19.6	18.2	46.0
0.710000	26.4	Off	L1	19.6	19.6	46.0
14.286000	30.3	Off	L1	20.4	19.7	50.0
18.094000	32.1	Off	L1	20.6	17.9	50.0
19.574000	33.8	Off	L1	20.7	16.2	50.0



Test Mode :	Mode 1	Temperature :	22~23°C
Test Engineer :	Arthur Hsieh	Relative Humidity :	50~51%
Test Voltage :	120Vac / 60Hz	Phase :	Neutral
Function Type :	Bluetooth Link + WLAN (5GHz) Link 802.11ac VHT80 MCS0 + LAN Link + USB Link + Adapter 1		

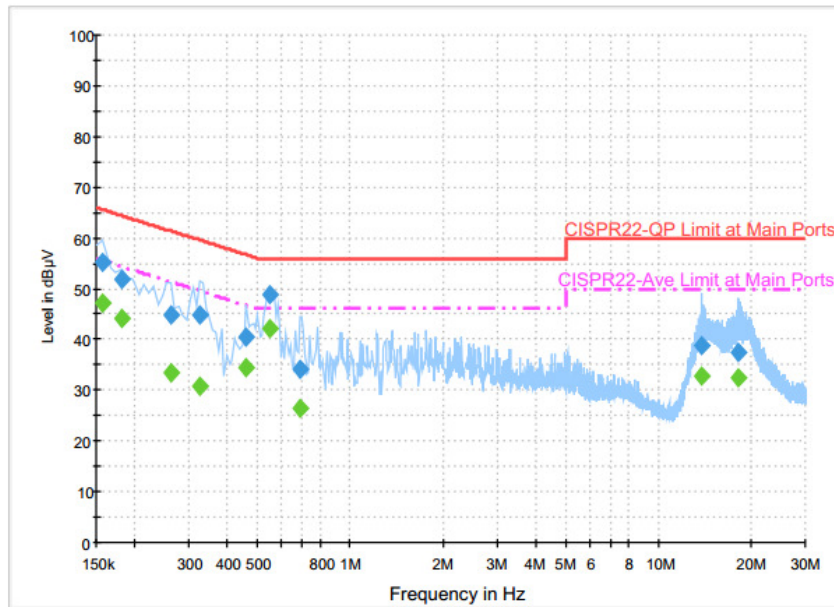

Final Result : QuasiPeak

Frequency (MHz)	QuasiPeak (dBµV)	Filter	Line	Corr. (dB)	Margin (dB)	Limit (dBµV)
0.158000	55.2	Off	N	19.6	10.4	65.6
0.182000	51.7	Off	N	19.6	12.7	64.4
0.262000	44.7	Off	N	19.6	16.7	61.4
0.326000	45.0	Off	N	19.6	14.6	59.6
0.462000	40.5	Off	N	19.6	16.2	56.7
0.550000	48.7	Off	N	19.6	7.3	56.0
0.686000	34.0	Off	N	19.6	22.0	56.0
13.870000	38.7	Off	N	20.4	21.3	60.0
18.254000	37.3	Off	N	20.6	22.7	60.0

Final Result : Average

Frequency (MHz)	Average (dBµV)	Filter	Line	Corr. (dB)	Margin (dB)	Limit (dBµV)
0.158000	47.0	Off	N	19.6	8.6	55.6
0.182000	44.0	Off	N	19.6	10.4	54.4
0.262000	33.4	Off	N	19.6	18.0	51.4
0.326000	30.9	Off	N	19.6	18.7	49.6
0.462000	34.4	Off	N	19.6	12.3	46.7
0.550000	42.1	Off	N	19.6	3.9	46.0
0.686000	26.4	Off	N	19.6	19.6	46.0
13.870000	32.9	Off	N	20.4	17.1	50.0
18.254000	32.3	Off	N	20.6	17.7	50.0

3.6 Frequency Stability Measurement

3.6.1 Limit of Frequency Stability

Manufacturers of U-NII devices are responsible for ensuring frequency stability such that an emission is maintained within the band of operation under all conditions of normal operation as specified in the user's manual.

3.6.2 Measuring Instruments

The measuring equipment is listed in the section 4 of this test report.

3.6.3 Test Procedures

1. To ensure emission at the band edge is maintained within the authorized band, those values shall be measured by radiation emissions at upper and lower frequency points, and finally compensated by frequency deviation as procedures below.
2. The EUT was operated at the maximum output power, and connected to the spectrum analyzer, which is set to maximum hold function and peak detector. The peak value of the power envelope was measured and noted. The upper and lower frequency points were respectively measured relatively 10dB lower than the measured peak value.
3. The frequency deviation was calculated by adding the upper frequency point and the lower frequency point divided by two. Those detailed values of frequency deviation are provided in table below.

3.6.4 Test Setup

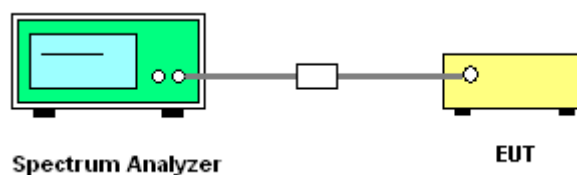

3.6.5 Test Result of Frequency Stability

Please refer to Appendix A.



3.7 Automatically Discontinue Transmission

3.7.1 Limit of Automatically Discontinue Transmission

The device shall automatically discontinue transmission in case of either absence of information to transmit or operational failure. These provisions are not intended to preclude the transmission of control or signaling information or the use of repetitive codes used by certain digital technologies to complete frame or burst intervals. Applicants shall include in their application for equipment authorization to describe how this requirement is met.

3.7.2 Measuring Instruments

The measuring equipment is listed in the section 4 of this test report.

3.7.3 Test Result of Automatically Discontinue Transmission

While the EUT is not transmitting any information, the EUT can automatically discontinue transmission and become standby mode for power saving. The EUT can detect the controlling signal of ACK message transmitting from remote device and verify whether it shall resend or discontinue transmission.



3.8 Antenna Requirements

3.8.1 Standard Applicable

According to FCC 47 CFR Section 15.407(a)(1)(2) ,if transmitting antenna directional gain is greater than 6 dBi, both the peak transmit power and the peak power spectral density shall be reduced by the amount in dB that the directional gain of the antenna exceeds 6 dBi.

3.8.2 Antenna Anti-Replacement Construction

An embedded-in antenna design is used.



3.8.3 Antenna Gain

CDD modes

FCC KDB 662911 D01 Multiple Transmitter Output v02r01

For CDD transmissions, directional gain is calculated as

Directional gain = $G_{ANT} + \text{Array Gain}$, where Array Gain is as follows.

For power spectral density (PSD) measurements on all devices,

Array Gain = $10 \log(N_{ANT}/N_{SS}=1)$ dB.

For power measurements on IEEE 802.11 devices,

Array Gain = 0 dB (i.e., no array gain) for $N_{ANT} \leq 4$.

Directional gain may be calculated by using the formulas applicable to equal gain antennas with G_{ANT} set equal to the gain of the antenna having the highest gain;

The EUT supports CDD mode.

For power, the directional gain G_{ANT} is set equal to the antenna having the highest gain, i.e., F)2)f)i).

For PSD, the directional gain calculation is following F)2)f)ii) of KDB 662911 D01 v02r01.

The power and PSD limit should be modified if the directional gain of EUT is over 6 dBi,

The directional gain "DG" is calculated as following table.

	Ant 1	Ant 2	Ant 3	Ant 4	DG for Power (dBi)	DG for PSD (dBi)	Power Limit Reduction (dB)	PSD Limit Reduction (dB)
5.3G Band	2.38	3.45	4.93	3.47	4.93	9.63	0.00	3.63
5.5G Band	4.34	3.36	5.30	4.58	5.30	10.44	0.00	4.44
5.8G Band	4.26	3.49	4.30	4.67	4.67	10.21	0.00	4.21

Power limit reduction = Composite gain – 6dBi, (min = 0)

PSD limit reduction = Composite gain + PSD Array gain – 6dBi, (min = 0)



TXBF modes

FCC KDB 662911 D01 Multiple Transmitter Output v02r01

For CDD transmissions, directional gain is calculated as

$$DirectionalGain = 10 \cdot \log \left[\frac{\sum_{j=1}^{N_{SS}} \left\{ \sum_{k=1}^{N_{ANT}} g_{j,k} \right\}^2}{N_{ANT}} \right]$$

where

Each antenna is driven by no more than one spatial stream;

N_{SS} = the number of independent spatial streams of data;

N_{ANT} = the total number of antennas

$g_{j,k} = 10^{G_k / 20}$ if the k th antenna is being fed by spatial stream j , or zero if it is not;
 G_k is the gain in dBi of the k th antenna.

The EUT supports beamforming for 802.11ac modes.

The directional gain calculation is following F2)e)ii) of KDB 662911 D01 v02r01.

The power and PSD limit should be modified if the directional gain of EUT is over 6 dBi,

The directional gain "DG" is calculated as following table.

					DG	DG	Power	PSD
					for	for	Limit	Limit
	Ant 1	Ant 2	Ant 3	Ant 4	Power	PSD	Reduction	Reduction
	(dBi)	(dBi)	(dBi)	(dBi)	(dBi)	(dBi)	(dB)	(dB)
5.3G Band	2.38	3.45	4.93	3.47	9.63	9.63	3.63	3.63
5.5G Band	4.34	3.36	5.30	4.58	10.44	10.44	4.44	4.44
5.8G Band	4.26	3.49	4.30	4.67	10.21	10.21	4.21	4.21

Power Limit Reduction = DG(Power) – 6dBi, (min = 0)

PSD Limit Reduction = DG(PSD) – 6dBi, (min = 0)



4 List of Measuring Equipment

Instrument	Manufacturer	Model No.	Serial No.	Characteristics	Calibration Date	Test Date	Due Date	Remark
Power Meter	Anritsu	ML2495A	1036004	300MHz~40GHz	Jul. 29, 2015	Jul. 25, 2016 ~ Jul. 26, 2016	Jul. 28, 2016	Conducted (TH02-HY)
Power Sensor	Anritsu	MA2411B	1027253	300MHz~40GHz	Jul. 29, 2015	Jul. 25, 2016 ~ Jul. 26, 2016	Jul. 28, 2016	Conducted (TH02-HY)
Spectrum Analyzer	Rohde & Schwarz	FSP40	100055	9kHz~40GHz	Jun. 17, 2016	Jul. 25, 2016 ~ Jul. 26, 2016	Jun. 16, 2017	Conducted (TH02-HY)
Temperature Chamber	ESPEC	SU-241	92003713	-30℃ ~95℃	Jun. 06, 2016	Jul. 25, 2016 ~ Jul. 26, 2016	Jun. 05, 2017	Conducted (TH02-HY)
AC Power Source	ChainTek	APC-1000W	N/A	N/A	N/A	Jun. 24, 2016	N/A	Conduction (CO05-HY)
EMI Test Receiver	Rohde & Schwarz	ESCI 7	100724	9kHz~7GHz	Aug. 26, 2015	Jun. 24, 2016	Aug. 25, 2016	Conduction (CO05-HY)
LISN	Rohde & Schwarz	ENV216	100080	9kHz~30MHz	Dec. 02, 2015	Jun. 24, 2016	Dec. 01, 2016	Conduction (CO05-HY)
LISN	Rohde & Schwarz	ENV216	100081	9kHz~30MHz	Dec. 14, 2015	Jun. 24, 2016	Dec. 13, 2016	Conduction (CO05-HY)
Loop Antenna	Rohde & Schwarz	HFH2-Z2	100315	9 kHz~30 MHz	Sep. 02, 2015	Jul. 20, 2016 ~ Jul. 25, 2016	Sep. 01, 2016	Radiation (03CH10-HY)
Amplifier	SONOMA	310N	187311	9kHz~1GHz	Nov. 16, 2015	Jul. 20, 2016 ~ Jul. 25, 2016	Nov. 15, 2016	Radiation (03CH10-HY)
Bilog Antenna	TESEQ	CBL 6111D	35413	30MHz~1GHz	Jan. 13, 2016	Jul. 20, 2016 ~ Jul. 25, 2016	Jan. 12, 2017	Radiation (03CH10-HY)
Horn Antenna	SCHWARZBECK	BBHA 9120 D	9120D-1325	1GHz ~ 18GHz	Sep. 30, 2015	Jul. 20, 2016 ~ Jul. 25, 2016	Sep. 29, 2016	Radiation (03CH10-HY)
Preamplifier	Keysight	83017A	MY53270078	1GHz~26.5GHz	Nov. 13, 2015	Jul. 20, 2016 ~ Jul. 25, 2016	Nov. 12, 2016	Radiation (03CH10-HY)
Preamplifier	MITEQ	TTA0204	1872107	2GHz~40GHz	Feb. 15, 2016	Jul. 20, 2016 ~ Jul. 25, 2016	Feb. 14, 2017	Radiation (03CH10-HY)
Spectrum Analyzer	Keysight	N9010A	MY54200485	10Hz ~ 44GHz	Oct. 15, 2015	Jul. 20, 2016 ~ Jul. 25, 2016	Oct. 14, 2016	Radiation (03CH10-HY)
Antenna Mast	EMEC	AM-BS-4500-B	N/A	1~4m	N/A	Jul. 20, 2016 ~ Jul. 25, 2016	N/A	Radiation (03CH10-HY)
Turn Table	EMEC	TT 2200	N/A	0~360 Degree	N/A	Jul. 20, 2016 ~ Jul. 25, 2016	N/A	Radiation (03CH10-HY)
EMI Test Receiver	Keysight	N9038A(MXE)	MY55420170	N/A	Mar. 10, 2016	Jul. 20, 2016 ~ Jul. 25, 2016	Mar. 09, 2017	Radiation (03CH10-HY)
SHF-EHF Horn Antenna	SCHWARZBECK	BBHA 9170	BBHA9170584	18GHz- 40GHz	Nov. 02, 2015	Jul. 20, 2016 ~ Jul. 25, 2016	Nov. 01, 2016	Radiation (03CH10-HY)



5 Uncertainty of Evaluation

Uncertainty of Conducted Emission Measurement (150kHz ~ 30MHz)

Measuring Uncertainty for a Level of Confidence of 95% ($U = 2Uc(y)$)	2.26
---	------

Uncertainty of Radiated Emission Measurement (30 MHz ~ 1000 MHz)

Measuring Uncertainty for a Level of Confidence of 95% ($U = 2Uc(y)$)	5.50
---	------

Uncertainty of Radiated Emission Measurement (1GHz ~ 40GHz)

Measuring Uncertainty for a Level of Confidence of 95% ($U = 2Uc(y)$)	4.90
---	------



Appendix A. Conducted Test Results

<CDD Modes>

Test Engineer:	Derek Hsu	Temperature:	21~25	°C
Test Date:	2016/07/25~2016/07/26	Relative Humidity:	51~54	%

TEST RESULTS DATA
26dB and 99% OBW

Band II													
Mod.	Data Rate	NTX	CH.	Freq. (MHz)	26 dB Bandwidth (MHz)				FCC 26dB Bandwidth Power Limit (dBm)				Note
					Ant 1	Ant 2	Ant 3	Ant 4	Ant 1	Ant 2	Ant 3	Ant 4	
11a	6Mbps	4	52	5260	21.31	21.06	20.85	21.16	23.98	23.98	23.98	23.98	
11a	6Mbps	4	60	5300	21.24	21.13	20.88	21.03	23.98	23.98	23.98	23.98	
11a	6Mbps	4	64	5320	21.30	21.03	20.82	21.06	23.98	23.98	23.98	23.98	

Band II																
Mod.	Data Rate	NTX	CH.	Freq. (MHz)	99% Bandwidth (MHz)				IC 99% Bandwidth Power Limit (dBm)				IC 99% Bandwidth EIRP Limit (dBm)			
					Ant 1	Ant 2	Ant 3	Ant 4	Ant 1	Ant 2	Ant 3	Ant 4	Ant 1	Ant 2	Ant 3	Ant 4
11a	6Mbps	3	52	5260	17.15	17.15	17.20	17.25	23.34	23.34	23.36	23.37	29.34	29.34	29.36	29.37
11a	6Mbps	3	60	5300	17.20	17.20	17.15	17.20	23.36	23.36	23.34	23.36	29.36	29.36	29.34	29.36
11a	6Mbps	3	64	5320	17.25	17.15	17.15	17.20	23.37	23.34	23.34	23.36	29.37	29.34	29.34	29.36

TEST RESULTS DATA
Average Power Table

FCC Band II															
Mod.	Data Rate	NTX	CH.	Freq. (MHz)	Ant	Average Conducted Power (dB)					FCC Power Limit (dBm)	DG (dBi)	FCC EIRP Power (dBm)	FCC EIRP Power Limit (dBm)	Pass/Fail
						Ant 1	Ant 2	Ant 3	Ant 4	SUM					
11a	6Mbps	4	52	5260	+2+3+4	12.41	12.59	13.18	13.28	18.90	23.98	4.93	23.83	30.00	Pass
11a	6Mbps	4	60	5300	+2+3+4	13.03	12.47	12.65	12.88	18.78	23.98	4.93	23.71	30.00	Pass
11a	6Mbps	4	64	5320	+2+3+4	13.24	12.21	12.69	12.68	18.74	23.98	4.93	23.67	30.00	Pass
HT20	MCS0	4	52	5260	+2+3+4	5.60	5.70	6.40	6.60	12.12	23.98	4.93	17.05	30.00	Pass
HT20	MCS0	4	60	5300	+2+3+4	6.90	6.40	6.80	6.80	12.75	23.98	4.93	17.68	30.00	Pass
HT20	MCS0	4	64	5320	+2+3+4	7.10	6.50	6.70	6.80	12.80	23.98	4.93	17.73	30.00	Pass
HT40	MCS0	4	54	5270	+2+3+4	8.10	8.20	8.90	8.80	14.53	23.98	4.93	19.46	30.00	Pass
HT40	MCS0	4	62	5310	+2+3+4	9.10	8.50	8.70	8.80	14.80	23.98	4.93	19.73	30.00	Pass

TEST RESULTS DATA
Power Spectral Density

Band II														
Mod.	Data Rate	NTX	CH.	Freq. (MHz)	Ant	Average PSD (dB)				Combined Average PSD (dBm/MHz)	PSD Limit (dBm/MHz)	DG (dBi)		Pass /Fail
						Ant 1	Ant 2	Ant 3	Ant 4					
11a	6Mbps	4	52	5260	+2+3+4	0.17	0.17	0.17	0.17	7.36	7.37	9.63		Pass
11a	6Mbps	4	60	5300	+2+3+4	0.17	0.17	0.17	0.17	7.05	7.37	9.63		Pass
11a	6Mbps	4	64	5320	+2+3+4	0.17	0.17	0.17	0.17	7.15	7.37	9.63		Pass

TEST RESULTS DATA
26dB and 99% OBW

Band III													
Mod.	Data Rate	NTX	CH.	Freq. (MHz)	26 dB Bandwidth (MHz)				FCC 26dB Bandwidth Power Limit (dBm)				Note
					Ant 1	Ant 2	Ant 3	Ant 4	Ant 1	Ant 2	Ant 3	Ant 4	
11a	6Mbps	4	100	5500	21.26	20.88	20.88	20.92	23.98	23.98	23.98	23.98	
11a	6Mbps	4	116	5580	21.28	21.06	20.88	21.02	23.98	23.98	23.98	23.98	
11a	6Mbps	4	140	5700	21.26	21.01	21.10	20.94	23.98	23.98	23.98	23.98	

Band III																
Mod.	Data Rate	NTX	CH.	Freq. (MHz)	99% Bandwidth (MHz)				IC 99% Bandwidth Power Limit (dBm)				IC 99% Bandwidth EIRP Limit (dBm)			
					Ant 1	Ant 2	Ant 3	Ant 4	Ant 1	Ant 2	Ant 3	Ant 4	Ant 1	Ant 2	Ant 3	Ant 4
11a	6Mbps	4	100	5500	17.20	17.10	17.15	17.25	23.36	23.33	23.34	23.37	29.36	29.33	29.34	29.37
11a	6Mbps	4	116	5580	17.20	17.20	17.25	17.15	23.36	23.36	23.37	23.34	29.36	29.36	29.37	29.34
11a	6Mbps	4	140	5700	17.20	17.20	17.25	17.15	23.36	23.36	23.37	23.34	29.36	29.36	29.37	29.34

TEST RESULTS DATA
Average Power Table

FCC Band III															
Mod.	Data Rate	NTX	CH.	Freq. (MHz)	Ant	Average Conducted Power (dB)					FCC Power Limit (dBm)	DG (dBi)	FCC EIRP Power (dBm)	FCC EIRP Power Limit (dBm)	Pass/Fail
						Ant 1	Ant 2	Ant 3	Ant 4	SUM					
11a	6Mbps	4	100	5500	+2+3+4	11.13	11.02	11.04	11.09	17.09	23.98	5.30	22.39	30.00	Pass
11a	6Mbps	4	116	5580	+2+3+4	10.75	10.71	10.88	11.13	16.89	23.98	5.30	22.19	30.00	Pass
11a	6Mbps	4	140	5700	+2+3+4	12.74	12.26	12.10	12.31	18.38	23.98	5.30	23.68	30.00	Pass
HT20	MCS0	4	100	5500	+2+3+4	5.50	6.00	5.70	6.00	11.83	23.98	5.30	17.13	30.00	Pass
HT20	MCS0	4	116	5580	+2+3+4	5.30	5.60	5.70	5.80	11.62	23.98	5.30	16.92	30.00	Pass
HT20	MCS0	4	140	5700	+2+3+4	6.20	5.80	5.80	6.20	12.03	23.98	5.30	17.33	30.00	Pass
HT40	MCS0	4	102	5510	+2+3+4	7.70	8.00	7.80	8.20	13.95	23.98	5.30	19.25	30.00	Pass
HT40	MCS0	4	110	5550	+2+3+4	7.10	7.50	7.50	7.80	13.50	23.98	5.30	18.80	30.00	Pass
HT40	MCS0	4	134	5670	+2+3+4	8.60	8.30	8.30	9.00	14.58	23.98	5.30	19.88	30.00	Pass

TEST RESULTS DATA
Power Spectral Density

Band III														
Mod.	Data Rate	NTX	CH.	Freq. (MHz)	Ant	Average PSD (dB)				Combined Average PSD (dBm/MHz)	PSD Limit (dBm/MHz)	DG (dBi)		Pass /Fail
						Ant 1	Ant 2	Ant 3	Ant 4					
11a	6Mbps	4	100	5500	+2+3+4	0.17	0.17	0.17	0.17	6.27	6.56	10.44		Pass
11a	6Mbps	4	116	5580	+2+3+4	0.17	0.17	0.17	0.17	6.12	6.56	10.44		Pass
11a	6Mbps	4	140	5700	+2+3+4	0.17	0.17	0.17	0.17	6.32	6.56	10.44		Pass

TEST RESULTS DATA
26dB and 99% OBW

Straddle Channel												
Mod.	Data Rate	NTX	CH.	Freq. (MHz)	Emission Bandwidth (MHz)				FCC 26dB Bandwidth Power Limit (dBm)			
					Ant 1	Ant 2	Ant 3	Ant 4	Ant 1	Ant 2	Ant 3	Ant 4
11a	6Mbps	4	144	5720	18.86	18.92	18.72	18.50	-			
				NII-2C	15.74	15.8	15.56	15.38	22.87			
				NII-3	3.12	3.12	3.16	3.12	-			

Straddle Channel																
Mod.	Data Rate	NTX	CH.	Freq. (MHz)	99% Bandwidth (MHz)				IC 99% Bandwidth Power Limit (dBm)				IC 99% Bandwidth EIRP Limit (dBm)			
					Ant 1	Ant 2	Ant 3	Ant 4	Ant 1	Ant 2	Ant 3	Ant 4	Ant 1	Ant 2	Ant 3	Ant 4
11a	6Mbps	4	144	5720	17.20	17.25	17.25	17.25	-				-			
				NII-2C	13.6	13.65	13.7	13.65	22.34				28.34			
				NII-3	3.6	3.6	3.55	3.60	-				-			

TEST RESULTS DATA
Average Power Table

FCC Straddle Channel															
Mod.	Data Rate	NTX	CH.	Freq. (MHz)	Average Conducted Power (dBm)					FCC Conducted Power Limit (dBm)				DG (dBi)	Pass/Fail
					Ant 1	Ant 2	Ant 3	Ant 4	SUM	Ant 1	Ant 2	Ant 3	Ant 4		
11a	6Mbps	4	144	5720	12.40	12.27	12.04	12.14	18.23	-	-	-	-	-	-
				NII-2C	11.46	11.38	11.07	11.27	17.32	22.87	5.30	Pass			
				NII-3	5.27	4.94	5.05	4.74	11.02	30.00	4.67	Pass			
HT20	MCS0	4	144	5720	8.51	8.10	8.11	8.66	14.37	-	-	-	-	-	
				NII-2C	7.51	7.10	7.05	7.67	13.36	23.98	5.30	Pass			
				NII-3	1.64	1.21	1.48	1.77	7.55	30.00	4.67	Pass			
HT40	MCS0	4	142	5710	13.43	13.05	12.80	12.85	19.06	-	-	-	-	-	
				NII-2C	13.11	12.75	12.53	12.54	18.76	23.98	5.30	Pass			
				NII-3	1.89	1.29	0.66	1.29	7.32	30.00	4.67	Pass			

IC Straddle Channel															
Mod.	Data Rate	NTX	CH.	Freq. (MHz)	Average Conducted Power (dBm)					IC 99% Bandwidth Power Limit (dBm)				DG (dBi)	Pass/Fail
					Ant 1	Ant 2	Ant 3	Ant 4	SUM	Ant 1	Ant 2	Ant 3	Ant 4		
11a	6Mbps	4	144	5720	12.40	12.27	12.04	12.14	18.23	-	-	-	-	-	-
				NII-2C	11.46	11.38	11.07	11.27	17.32	22.34	5.30	Pass			
				NII-3	5.27	4.94	5.05	4.74	11.02	30.00	4.67	Pass			
HT20	MCS0	4	144	5720	8.51	8.10	8.11	8.66	14.37	-	-	-	-	-	
				NII-2C	7.51	7.10	7.05	7.67	13.36	22.49	5.30	Pass			
				NII-3	1.64	1.21	1.48	1.77	7.55	30.00	4.67	Pass			
HT40	MCS0	4	142	5710	13.43	13.05	12.80	12.85	19.06	-	-	-	-	-	
				NII-2C	13.11	12.75	12.53	12.54	18.76	23.98	5.30	Pass			
				NII-3	1.89	1.29	0.66	1.29	7.32	30.00	4.67	Pass			
VHT20	MCS0	4	144	5720	9.01	8.22	7.94	8.30	14.40	-	-	-	-	-	
				NII-2C	7.96	7.10	6.83	7.30	13.34	22.55	5.30	Pass			
				NII-3	2.31	1.79	1.45	1.41	7.78	30.00	4.67	Pass			
VHT40	MCS0	4	142	5710	13.34	13.29	13.15	13.03	19.22	-	-	-	-	-	
				NII-2C	12.89	12.92	12.73	12.60	18.81	23.98	5.30	Pass			
				NII-3	3.26	2.45	2.75	2.75	8.83	30.00	4.67	Pass			
VHT80	MCS0	4	138	5690	14.23	12.90	13.61	13.63	19.64	-	-	-	-	-	
				NII-2C	14.04	12.67	13.47	13.46	19.46	23.98	5.30	Pass			
				NII-3	0.56	0.08	-1.30	-0.66	5.75	30.00	4.67	Pass			

TEST RESULTS DATA
Power Spectral Density

Straddle Channel															
Mod.	Data Rate	NTX	CH.	Freq. (MHz)	Average Power Density (dBm/MHz)					Average PSD Limit (dBm/MHz)				DG (dBi)	Pass /Fail
					Ant 1	Ant 2	Ant 3	Ant 4	SUM	Ant 1	Ant 2	Ant 3	Ant 4		
11a	6Mbps	4	144	NII-2C	-				6.32	6.56				10.44	Pass
				NII-3					6.32	-				10.21	Pass

TEST RESULTS DATA
Frequency Stability

Band II										
Mod.	Data Rate	N _{TX}	CH.	Freq. (MHz)	Center Frequency (MHz)	Frequency Deviation (MHz)	Frequency Stability (ppm)	Temperature (°C)	Voltage (V)	Note
11a	6Mbps	1	64	5320	5319.950	-0.050	-9.40	20	99	
11a	6Mbps	1	64	5320	5320.000	0.000	0.00	20	121	
11a	6Mbps	1	64	5320	5319.950	-0.050	-9.40	20	110	
11a	6Mbps	1	64	5320	5320.000	0.000	0.00	-30	110	
11a	6Mbps	1	64	5320	5320.000	0.000	0.00	50	110	

Band III										
Mod.	Data Rate	N _{TX}	CH.	Freq. (MHz)	Center Frequency (MHz)	Frequency Deviation (MHz)	Frequency Stability (ppm)	Temperature (°C)	Voltage (V)	Note
11a	6Mbps	1	100	5500	5500.000	0.000	0.00	20	99	
11a	6Mbps	1	100	5500	5500.000	0.000	0.00	20	121	
11a	6Mbps	1	100	5500	5500.000	0.000	0.00	20	110	
11a	6Mbps	1	100	5500	5500.000	0.000	0.00	-30	110	
11a	6Mbps	1	100	5500	5499.950	-0.050	-9.09	50	110	



<TXBF Modes>

Test Engineer:	Derek Hsu	Temperature:	21~25	°C
Test Date:	2016/07/25~2016/07/26	Relative Humidity:	51~54	%

TEST RESULTS DATA
26dB and 99% OBW

Band II													
Mod.	Data Rate	NTX	CH.	Freq. (MHz)	26 dB Bandwidth (MHz)				FCC 26dB Bandwidth Power Limit (dBm)				Note
					Ant 1	Ant 2	Ant 3	Ant 4	Ant 1	Ant 2	Ant 3	Ant 4	
VHT20	MCS0	4	52	5260	24.11	23.56	24.04	23.34	23.98	23.98	23.98	23.98	
VHT20	MCS0	4	60	5300	23.22	23.46	24.44	24.16	23.98	23.98	23.98	23.98	
VHT20	MCS0	4	64	5320	23.76	23.33	23.80	23.34	23.98	23.98	23.98	23.98	
VHT40	MCS0	4	54	5270	43.11	42.66	42.48	41.67	23.98	23.98	23.98	23.98	
VHT40	MCS0	4	62	5310	43.47	42.39	43.65	40.77	23.98	23.98	23.98	23.98	
VHT80	MCS0	4	58	5290	83.20	82.72	82.72	84.80	23.98	23.98	23.98	23.98	

Band II																
Mod.	Data Rate	NTX	CH.	Freq. (MHz)	99% Bandwidth (MHz)				IC 99% Bandwidth Power Limit (dBm)				IC 99% Bandwidth EIRP Limit (dBm)			
					Ant 1	Ant 2	Ant 3	Ant 4	Ant 1	Ant 2	Ant 3	Ant 4	Ant 1	Ant 2	Ant 3	Ant 4
VHT20	MCS0	3	52	5260	18.85	18.60	18.80	18.60	23.75	23.70	23.74	23.70	29.75	29.70	29.74	29.70
VHT20	MCS0	3	60	5300	18.65	18.60	18.90	18.70	23.71	23.70	23.76	23.72	29.71	29.70	29.76	29.72
VHT20	MCS0	3	64	5320	18.90	18.60	18.75	18.75	23.76	23.70	23.73	23.73	29.76	29.70	29.73	29.73
VHT40	MCS0	3	54	5270	36.70	36.90	36.60	36.80	23.98	23.98	23.98	23.98	30.00	30.00	30.00	30.00
VHT40	MCS0	3	62	5310	36.80	36.70	36.70	36.70	23.98	23.98	23.98	23.98	30.00	30.00	30.00	30.00
VHT80	MCS0	3	58	5290	75.96	75.96	75.96	76.20	23.98	23.98	23.98	23.98	30.00	30.00	30.00	30.00

TEST RESULTS DATA
Average Power Table

FCC Band II															
Mod.	Data Rate	NTX	CH.	Freq. (MHz)	Ant	Average Conducted Power (dB)					FCC Power Limit (dBm)	DG (dBi)	FCC EIRP Power (dBm)	FCC EIRP Power Limit (dBm)	Pass/Fail
						Ant 1	Ant 2	Ant 3	Ant 4	SUM					
VHT20	MCS0	4	52	5260	+2+3+4	7.30	6.90	5.90	5.40	12.46	20.35	9.63	22.09	30.00	Pass
VHT20	MCS0	4	60	5300	+2+3+4	7.50	7.00	6.60	6.10	12.85	20.35	9.63	22.48	30.00	Pass
VHT20	MCS0	4	64	5320	+2+3+4	7.50	6.70	6.50	6.40	12.82	20.35	9.63	22.44	30.00	Pass
VHT40	MCS0	4	54	5270	+2+3+4	9.20	8.80	8.30	7.70	14.56	20.35	9.63	24.18	30.00	Pass
VHT40	MCS0	4	62	5310	+2+3+4	9.20	9.00	8.70	8.20	14.81	20.35	9.63	24.44	30.00	Pass
VHT80	MCS0	4	58	5290	+2+3+4	12.70	12.10	11.80	11.40	18.05	20.35	9.63	27.67	30.00	Pass

TEST RESULTS DATA
Power Spectral Density

Band II														
Mod.	Data Rate	NTX	CH.	Freq. (MHz)	Ant	Average PSD (dB)				Combined Average PSD (dBm/MHz)	PSD Limit (dBm/MHz)	DG (dBi)		Pass /Fail
						Ant 1	Ant 2	Ant 3	Ant 4					
VHT20	MCS0	4	52	5260	+2+3+4	-	-	-	-	6.43	7.37	9.63		Pass
VHT20	MCS0	4	60	5300	+2+3+4	-	-	-	-	6.81	7.37	9.63		Pass
VHT20	MCS0	4	64	5320	+2+3+4	-	-	-	-	6.81	7.37	9.63		Pass
VHT40	MCS0	4	54	5270	+2+3+4	-	-	-	-	6.39	7.37	9.63		Pass
VHT40	MCS0	4	62	5310	+2+3+4	-	-	-	-	6.76	7.37	9.63		Pass
VHT80	MCS0	4	58	5290	+2+3+4	-	-	-	-	7.22	7.37	9.63		Pass

TEST RESULTS DATA
26dB and 99% OBW

Band III													
Mod.	Data Rate	NTX	CH.	Freq. (MHz)	26 dB Bandwidth (MHz)				FCC 26dB Bandwidth Power Limit (dBm)				Note
					Ant 1	Ant 2	Ant 3	Ant 4	Ant 1	Ant 2	Ant 3	Ant 4	
VHT20	MCS0	4	100	5500	23.51	23.52	24.00	24.70	23.98	23.98	23.98	23.98	
VHT20	MCS0	4	116	5580	24.84	23.97	22.86	24.00	23.98	23.98	23.98	23.98	
VHT20	MCS0	4	140	5700	24.50	24.54	23.29	24.66	23.98	23.98	23.98	23.98	
VHT40	MCS0	4	102	5510	42.39	43.65	42.48	42.21	23.98	23.98	23.98	23.98	
VHT40	MCS0	4	110	5550	42.84	43.02	42.48	42.93	23.98	23.98	23.98	23.98	
VHT40	MCS0	4	134	5670	43.02	42.39	42.21	44.37	23.98	23.98	23.98	23.98	
VHT80	MCS0	4	106	5530	83.52	84.48	84.00	84.00	23.98	23.98	23.98	23.98	
VHT80	MCS0	4	122	5610	85.76	83.52	84.00	85.28	23.98	23.98	23.98	23.98	

Band III																
Mod.	Data Rate	NTX	CH.	Freq. (MHz)	99% Bandwidth (MHz)				IC 99% Bandwidth Power Limit (dBm)				IC 99% Bandwidth EIRP Limit (dBm)			
					Ant 1	Ant 2	Ant 3	Ant 4	Ant 1	Ant 2	Ant 3	Ant 4	Ant 1	Ant 2	Ant 3	Ant 4
VHT20	MCS0	4	100	5500	18.70	18.65	18.90	18.80	23.72	23.71	23.76	23.74	29.72	29.71	29.76	29.74
VHT20	MCS0	4	116	5580	18.80	18.60	18.65	18.75	23.74	23.70	23.71	23.73	29.74	29.70	29.71	29.73
VHT20	MCS0	4	140	5700	18.90	18.70	18.75	18.75	23.76	23.72	23.73	23.73	29.76	29.72	29.73	29.73
VHT40	MCS0	4	102	5510	36.60	36.80	36.70	36.90	23.98	23.98	23.98	23.98	30.00	30.00	30.00	30.00
VHT40	MCS0	4	110	5550	36.80	37.10	36.70	37.00	23.98	23.98	23.98	23.98	30.00	30.00	30.00	30.00
VHT40	MCS0	4	134	5670	36.70	36.90	36.80	36.90	23.98	23.98	23.98	23.98	30.00	30.00	30.00	30.00
VHT80	MCS0	4	106	5530	76.08	76.08	76.08	76.08	23.98	23.98	23.98	23.98	30.00	30.00	30.00	30.00
VHT80	MCS0	4	122	5610	76.32	76.20	76.32	76.32	23.98	23.98	23.98	23.98	30.00	30.00	30.00	30.00

TEST RESULTS DATA
Average Power Table

FCC Band III															
Mod.	Data Rate	NTX	CH.	Freq. (MHz)	Ant	Average Conducted Power (dB)					FCC Power Limit (dBm)	DG (dBi)	FCC EIRP Power (dBm)	FCC EIRP Power Limit (dBm)	Pass/Fail
						Ant 1	Ant 2	Ant 3	Ant 4	SUM					
VHT20	MCS0	4	100	5500	+2+3+4	6.40	5.40	6.00	5.90	11.96	19.54	10.44	22.40	30.00	Pass
VHT20	MCS0	4	116	5580	+2+3+4	5.90	5.30	5.80	5.40	11.63	19.54	10.44	22.07	30.00	Pass
VHT20	MCS0	4	140	5700	+2+3+4	6.90	6.40	6.50	6.00	12.48	19.54	10.44	22.93	30.00	Pass
VHT40	MCS0	4	102	5510	+2+3+4	8.50	7.70	8.10	7.90	14.08	19.54	10.44	24.52	30.00	Pass
VHT40	MCS0	4	110	5550	+2+3+4	7.80	7.30	7.50	7.40	13.52	19.54	10.44	23.97	30.00	Pass
VHT40	MCS0	4	134	5670	+2+3+4	8.90	8.50	8.70	8.50	14.67	19.54	10.44	25.12	30.00	Pass
VHT80	MCS0	4	106	5530	+2+3+4	11.30	10.30	10.40	10.50	16.66	19.54	10.44	27.11	30.00	Pass
VHT80	MCS0	4	122	5610	+2+3+4	11.60	11.00	10.90	11.00	17.15	19.54	10.44	27.60	30.00	Pass

TEST RESULTS DATA
Power Spectral Density

Band III														
Mod.	Data Rate	NTX	CH.	Freq. (MHz)	Ant	Average PSD (dB)				Combined Average PSD (dBm/MHz)	PSD Limit (dBm/MHz)	DG (dBi)		Pass /Fail
						Ant 1	Ant 2	Ant 3	Ant 4					
VHT20	MCS0	4	100	5500	+2+3+4	-	-	-	-	5.99	6.56	10.44		Pass
VHT20	MCS0	4	116	5580	+2+3+4	-	-	-	-	6.19	6.56	10.44		Pass
VHT20	MCS0	4	140	5700	+2+3+4	-	-	-	-	5.59	6.56	10.44		Pass
VHT40	MCS0	4	102	5510	+2+3+4	-	-	-	-	6.29	6.56	10.44		Pass
VHT40	MCS0	4	110	5550	+2+3+4	-	-	-	-	6.07	6.56	10.44		Pass
VHT40	MCS0	4	134	5670	+2+3+4	-	-	-	-	6.00	6.56	10.44		Pass
VHT80	MCS0	4	106	5530	+2+3+4	-	-	-	-	6.46	6.56	10.44		Pass
VHT80	MCS0	4	122	5610	+2+3+4	-	-	-	-	5.62	6.56	10.44		Pass

TEST RESULTS DATA
26dB and 99% OBW

Straddle Channel									
Mod.	Data Rate	NTX	CH.	Freq. (MHz)	Emission Bandwidth (MHz)				FCC 26dB Bandwidth Power Limit (dBm)
					Ant 1	Ant 2	Ant 3	Ant 4	
VHT20	MCS0	4	144	5720	20.14	19.84	20.08	19.44	-
				NII-2C	17.3	16.64	16.88	16.88	23.21
				NII-3	2.84	3.2	3.2	2.56	-
VHT40	MCS0	4	142	5710	39.47	39.35	39.38	39.15	-
				NII-2C	36.87	36.51	36.78	36.15	23.98
				NII-3	2.6	2.84	2.6	3.00	-
VHT80	MCS0	4	138	5690	80.32	79.52	80.00	79.04	-
				NII-2C	77.72	76.92	77.4	76.44	23.98
				NII-3	2.6	2.6	2.6	2.60	-

Straddle Channel										
Mod.	Data Rate	NTX	CH.	Freq. (MHz)	99% Bandwidth (MHz)				IC 99% Bandwidth Power Limit (dBm)	IC 99% Bandwidth EIRP Limit (dBm)
					Ant 1	Ant 2	Ant 3	Ant 4		
VHT20	MCS0	4	144	5720	18.85	18.65	18.90	18.75	-	-
				NII-2C	14.4	14.35	14.4	14.30	22.55	28.55
				NII-3	4.45	4.3	4.5	4.45	-	-
VHT40	MCS0	4	142	5710	36.90	36.90	36.90	36.90	-	-
				NII-2C	33.4	33.4	33.3	33.30	23.98	30.00
				NII-3	3.5	3.5	3.6	3.60	-	-
VHT80	MCS0	4	138	5690	76.20	76.44	76.32	76.20	-	-
				NII-2C	72.92	73.16	73.16	72.92	23.98	30.00
				NII-3	3.28	3.28	3.16	3.28	-	-

TEST RESULTS DATA
Average Power Table

FCC Straddle Channel												
Mod.	Data Rate	NTX	CH.	Freq. (MHz)	Average Conducted Power (dBm)					FCC Conducted Power Limit (dBm)	DG (dBi)	Pass/Fail
					Ant 1	Ant 2	Ant 3	Ant 4	SUM			
VHT20	MCS0	4	144	5720	9.01	8.22	7.94	8.30	14.40	-	-	-
				NII-2C	7.96	7.10	6.83	7.30	13.34	18.77	10.44	Pass
				NII-3	2.31	1.79	1.45	1.41	7.78	25.79	10.21	Pass
VHT40	MCS0	4	142	5710	13.34	13.29	13.15	13.03	19.22	-	-	-
				NII-2C	12.89	12.92	12.73	12.60	18.81	19.54	10.44	Pass
				NII-3	3.26	2.45	2.75	2.75	8.83	25.79	10.21	Pass
VHT80	MCS0	4	138	5690	14.23	12.90	13.61	13.63	19.64	-	-	-
				NII-2C	14.04	12.67	13.47	13.46	19.46	19.54	10.44	Pass
				NII-3	0.56	0.08	-1.30	-0.66	5.75	25.79	10.21	Pass

IC Straddle Channel												
Mod.	Data Rate	NTX	CH.	Freq. (MHz)	Average Conducted Power (dBm)					IC 99% Bandwidth Power Limit (dBm)	DG (dBi)	Pass/Fail
					Ant 1	Ant 2	Ant 3	Ant 4	SUM			
11a	6Mbps	4	144	5720	12.40	12.27	12.04	12.14	18.23	-	-	-
				NII-2C	11.46	11.38	11.07	11.27	17.32	17.89	10.44	Pass
				NII-3	5.27	4.94	5.05	4.74	11.02	25.79	10.21	Pass
HT20	MCS0	4	144	5720	8.51	8.10	8.11	8.66	14.37	-	-	-
				NII-2C	7.51	7.10	7.05	7.67	13.36	18.05	10.44	Pass
				NII-3	1.64	1.21	1.48	1.77	7.55	25.79	10.21	Pass
HT40	MCS0	4	142	5710	13.43	13.05	12.80	12.85	19.06	-	-	-
				NII-2C	13.11	12.75	12.53	12.54	18.76	19.54	10.44	Pass
				NII-3	1.89	1.29	0.66	1.29	7.32	25.79	10.21	Pass
VHT20	MCS0	4	144	5720	9.01	8.22	7.94	8.30	14.40	-	-	-
				NII-2C	7.96	7.10	6.83	7.30	13.34	18.11	10.44	Pass
				NII-3	2.31	1.79	1.45	1.41	7.78	25.79	10.21	Pass
VHT40	MCS0	4	142	5710	13.34	13.29	13.15	13.03	19.22	-	-	-
				NII-2C	12.89	12.92	12.73	12.60	18.81	19.54	10.44	Pass
				NII-3	3.26	2.45	2.75	2.75	8.83	25.79	10.21	Pass
VHT80	MCS0	4	138	5690	14.23	12.90	13.61	13.63	19.64	-	-	-
				NII-2C	14.04	12.67	13.47	13.46	19.46	19.54	10.44	Pass
				NII-3	0.56	0.08	-1.30	-0.66	5.75	25.79	10.21	Pass

TEST RESULTS DATA
Power Spectral Density

Straddle Channel													
Mod.	Data Rate	NTX	CH.	Freq. (MHz)	Average Power Density (dBm/MHz)					Average PSD Limit (dBm/MHz)	DG (dBi)	Pass /Fail	
					Ant 1	Ant 2	Ant 3	Ant 4	SUM				
VHT20	MCS0	4	144	NII-2C						5.99	6.56	10.44	Pass
				NII-3						5.99	-	10.21	Pass
VHT40	MCS0	4	142	NII-2C						5.94	6.56	10.44	Pass
				NII-3						5.94	-	10.21	Pass
VHT80	MCS0	4	138	NII-2C						4.67	6.56	10.44	Pass
				NII-3						4.67	-	10.21	Pass



Appendix B. Radiated Spurious Emission

Test Engineer :	Tsung Lee, Stan Hsieh and Wilson Wu	Temperature :	25~26°C
		Relative Humidity :	48~49%

Band 2 - 5250~5350MHz

WIFI 802.11a (Band Edge @ 3m)

WIFI	Note	Frequency	Level	Over	Limit	Read	Antenna	Cable	Preamp	Ant	Table	Peak	Pol.
Ant.				Limit	Line	Level	Factor	Loss	Factor	Pos	Pos	Avg.	
1+2		(MHz)	(dBμV/m)	(dB)	(dBμV/m)	(dBμV)	(dB/m)	(dB)	(dB)	(cm)	(deg)	(P/A)	(H/V)
802.11a CH 52 5260MHz		5096.72	48.52	-25.48	74	41.21	31.92	7.96	32.57	100	63	P	H
		5000	40.5	-13.5	54	33.22	31.8	8.05	32.57	100	63	A	H
	*	5260	108.3	-	-	100.63	32.12	8.12	32.57	100	63	P	H
	*	5260	103.36	-	-	95.69	32.12	8.12	32.57	100	63	A	H
		5357.04	48.22	-25.78	74	40.34	32.22	8.23	32.57	100	63	P	H
		5359.2	39.67	-14.33	54	31.79	32.22	8.23	32.57	100	63	A	H
		5000.26	49.69	-24.31	74	42.41	31.8	8.05	32.57	108	283	P	V
		5000	43.81	-10.19	54	36.53	31.8	8.05	32.57	108	283	A	V
	*	5260	117.74	-	-	110.07	32.12	8.12	32.57	108	283	P	V
	*	5260	111.89	-	-	104.22	32.12	8.12	32.57	108	283	A	V
		5357.52	51.01	-22.99	74	43.13	32.22	8.23	32.57	108	283	P	V
		5352.96	42.94	-11.06	54	35.06	32.22	8.23	32.57	108	283	A	V
802.11a CH 60 5300MHz		5005.46	48.36	-25.64	74	41.09	31.82	8.02	32.57	100	62	P	H
		5000	40.57	-13.43	54	33.29	31.8	8.05	32.57	100	62	A	H
	*	5300	110.53	-	-	102.76	32.16	8.18	32.57	100	62	P	H
	*	5300	104	-	-	96.23	32.16	8.18	32.57	100	62	A	H
		5353.2	48.55	-25.45	74	40.67	32.22	8.23	32.57	100	62	P	H
		5352.72	40.98	-13.02	54	33.1	32.22	8.23	32.57	100	62	A	H
		5141.7	49.7	-24.3	74	42.35	31.98	7.94	32.57	106	282	P	V
		5000	45.11	-8.89	54	37.83	31.8	8.05	32.57	106	282	A	V
	*	5300	117.34	-	-	109.57	32.16	8.18	32.57	106	282	P	V
	*	5300	111.98	-	-	104.21	32.16	8.18	32.57	106	282	A	V
		5353.92	52.99	-21.01	74	45.11	32.22	8.23	32.57	106	282	P	V
		5351.04	45.63	-8.37	54	37.75	32.22	8.23	32.57	106	282	A	V



802.11a CH 64 5320MHz	*	5320	111.05	-	-	103.26	32.18	8.18	32.57	100	67	P	H
	*	5320	104.03	-	-	96.24	32.18	8.18	32.57	100	67	A	H
		5360.8	49.97	-24.03	74	42.07	32.24	8.23	32.57	100	67	P	H
		5350.08	41.58	-12.42	54	33.7	32.22	8.23	32.57	100	67	A	H
													H
													H
	*	5320	117.63	-	-	109.84	32.18	8.18	32.57	105	281	P	V
	*	5320	111.76	-	-	103.97	32.18	8.18	32.57	105	281	A	V
		5365.28	55.29	-18.71	74	47.33	32.24	8.29	32.57	105	281	P	V
		5363.36	47.06	-6.94	54	39.1	32.24	8.29	32.57	105	281	A	V
													V
													V
Remark	1. No other spurious found. 2. All results are PASS against Peak and Average limit line.												



Band 2 5250~5350MHz

WIFI 802.11a (Harmonic @ 3m)

WIFI Ant. 1+2	Note	Frequency (MHz)	Level (dBμV/m)	Over Limit (dB)	Limit Line (dBμV/m)	Read Level (dBμV)	Antenna Factor (dB/m)	Cable Loss (dB)	Preamp Factor (dB)	Ant Pos (cm)	Table Pos (deg)	Peak Avg. (P/A)	Pol. (H/V)	
802.11a CH 52 5260MHz		10520	49.76	-24.24	74	48.67	39.91	12.08	50.9	100	0	P	H	
		15780	48.75	-25.25	74	48.23	37.66	14.82	51.96	100	0	P	H	
													H	
													H	
			10520	49.25	-24.75	74	48.16	39.91	12.08	50.9	100	0	P	V
			15780	48.11	-25.89	74	47.59	37.66	14.82	51.96	100	0	P	V
														V
														V
802.11a CH 60 5300MHz		10600	48.46	-25.54	74	47.29	39.98	12.11	50.92	100	0	P	H	
		15900	47.55	-26.45	74	47.21	37.47	14.85	51.98	100	0	P	H	
													H	
													H	
			10600	49.59	-24.41	74	48.42	39.98	12.11	50.92	100	0	P	V
			15900	47.47	-26.53	74	47.13	37.47	14.85	51.98	100	0	P	V
														V
														V
802.11a CH 64 5320MHz		10640	49.14	-24.86	74	47.92	40.01	12.13	50.92	100	0	P	H	
		15960	48.25	-25.75	74	48.01	37.36	14.87	51.99	100	0	P	H	
													H	
													H	
			10640	49.32	-24.68	74	48.1	40.01	12.13	50.92	100	0	P	V
			15960	48.06	-25.94	74	47.82	37.36	14.87	51.99	100	0	P	V
														V
														V
Remark	1. No other spurious found. 2. All results are PASS against Peak and Average limit line.													



Band 2 5250~5350MHz

WIFI 802.11ac VHT20 (Band Edge @ 3m)

WIFI Ant. 1+2	Note	Frequency (MHz)	Level (dBμV/m)	Over Limit (dB)	Limit Line (dBμV/m)	Read Level (dBμV)	Antenna Factor (dB/m)	Cable Loss (dB)	Preamp Factor (dB)	Ant Pos (cm)	Table Pos (deg)	Peak Avg. (P/A)	Pol. (H/V)
802.11ac VHT20 CH 52 5260MHz		5028.08	48.12	-25.88	74	40.83	31.84	8.02	32.57	100	290	P	H
		5000	41.24	-12.76	54	33.96	31.8	8.05	32.57	100	290	A	H
	*	5260	100.5	-	-	92.83	32.12	8.12	32.57	100	290	P	H
	*	5260	94.45	-	-	86.78	32.12	8.12	32.57	100	290	A	H
		5359.68	47.36	-26.64	74	39.48	32.22	8.23	32.57	100	290	P	H
		5443.68	39.02	-14.98	54	30.98	32.32	8.29	32.57	100	290	A	H
		5137.54	47.6	-26.4	74	40.27	31.96	7.94	32.57	100	224	P	V
		5000	40.36	-13.64	54	33.08	31.8	8.05	32.57	100	224	A	V
	*	5260	107.92	-	-	100.25	32.12	8.12	32.57	100	224	P	V
	*	5260	101.48	-	-	93.81	32.12	8.12	32.57	100	224	A	V
		5366.4	50.99	-23.01	74	43.03	32.24	8.29	32.57	100	224	P	V
	5435.76	41.31	-12.69	54	33.27	32.32	8.29	32.57	100	224	A	V	
802.11ac VHT20 CH 60 5300MHz		5021.84	47.66	-26.34	74	40.37	31.84	8.02	32.57	100	301	P	H
		5000	40.67	-13.33	54	33.39	31.8	8.05	32.57	100	301	A	H
	*	5300	101.39	-	-	93.62	32.16	8.18	32.57	100	301	P	H
	*	5300	94.41	-	-	86.64	32.16	8.18	32.57	100	301	A	H
		5451.12	47.43	-26.57	74	39.37	32.34	8.29	32.57	100	301	P	H
		5379.6	39.26	-14.74	54	31.28	32.26	8.29	32.57	100	301	A	H
		5092.56	47.94	-26.06	74	40.63	31.92	7.96	32.57	100	223	P	V
		5000	40.18	-13.82	54	32.9	31.8	8.05	32.57	100	223	A	V
	*	5300	106.5	-	-	98.73	32.16	8.18	32.57	100	223	P	V
	*	5300	100.64	-	-	92.87	32.16	8.18	32.57	100	223	A	V
		5355.6	49.93	-24.07	74	42.05	32.22	8.23	32.57	100	223	P	V
	5351.52	41.51	-12.49	54	33.63	32.22	8.23	32.57	100	223	A	V	



802.11ac VHT20 CH 64 5320MHz	*	5320	100.47	-	-	92.68	32.18	8.18	32.57	100	295	P	H
	*	5320	94.47	-	-	86.68	32.18	8.18	32.57	100	295	A	H
		5350.56	48.51	-25.49	74	40.63	32.22	8.23	32.57	100	295	P	H
		5361.76	39.38	-14.62	54	31.42	32.24	8.29	32.57	100	295	A	H
													H
													H
	*	5320	105.7	-	-	97.91	32.18	8.18	32.57	100	223	P	V
	*	5320	99.95	-	-	92.16	32.18	8.18	32.57	100	223	A	V
		5402.4	50.12	-23.88	74	42.12	32.28	8.29	32.57	100	223	P	V
		5352.96	41.95	-12.05	54	34.07	32.22	8.23	32.57	100	223	A	V
													V
													V
Remark	1. No other spurious found. 2. All results are PASS against Peak and Average limit line.												



Band 2 5250~5350MHz

WIFI 802.11ac VHT20 (Harmonic @ 3m)

WIFI Ant. 1+2	Note	Frequency (MHz)	Level (dBμV/m)	Over Limit (dB)	Limit Line (dBμV/m)	Read Level (dBμV)	Antenna Factor (dB/m)	Cable Loss (dB)	Preamp Factor (dB)	Ant Pos (cm)	Table Pos (deg)	Peak Avg. (P/A)	Pol. (H/V)	
802.11ac VHT20 CH 52 5260MHz		10520	48.95	-25.05	74	47.86	39.91	12.08	50.9	100	0	P	H	
		15780	48.49	-25.51	74	47.97	37.66	14.82	51.96	100	0	P	H	
													H	
													H	
			10520	49.86	-24.14	74	48.77	39.91	12.08	50.9	100	0	P	V
			15780	48.98	-25.02	74	48.46	37.66	14.82	51.96	100	0	P	V
														V
802.11ac VHT20 CH 60 5300MHz		10600	50.55	-23.45	74	49.38	39.98	12.11	50.92	100	0	P	H	
		15900	49.42	-24.58	74	49.08	37.47	14.85	51.98	100	0	P	H	
													H	
													H	
			10600	49.92	-24.08	74	48.75	39.98	12.11	50.92	100	0	P	V
			15900	48.97	-25.03	74	48.63	37.47	14.85	51.98	100	0	P	V
														V
802.11ac VHT20 CH 64 5320MHz		10640	49.92	-24.08	74	48.7	40.01	12.13	50.92	100	0	P	H	
		15960	48.9	-25.1	74	48.66	37.36	14.87	51.99	100	0	P	H	
													H	
													H	
			10640	49.35	-24.65	74	48.13	40.01	12.13	50.92	100	0	P	V
			15960	48.06	-25.94	74	47.82	37.36	14.87	51.99	100	0	P	V
														V
Remark	1. No other spurious found.													
	2. All results are PASS against Peak and Average limit line.													



Band 2 5250~5350MHz

WIFI 802.11ac VHT40 (Band Edge @ 3m)

WIFI Ant. 1+2	Note	Frequency (MHz)	Level (dBμV/m)	Over Limit (dB)	Limit Line (dBμV/m)	Read Level (dBμV)	Antenna Factor (dB/m)	Cable Loss (dB)	Preamp Factor (dB)	Ant Pos (cm)	Table Pos (deg)	Peak Avg. (P/A)	Pol. (H/V)
802.11ac VHT40 CH 54 5270MHz		5144.3	47.23	-26.77	74	39.88	31.98	7.94	32.57	100	298	P	H
		5000	41.63	-12.37	54	34.35	31.8	8.05	32.57	100	298	A	H
	*	5270	100.04	-	-	92.37	32.12	8.12	32.57	100	298	P	H
	*	5270	93.97	-	-	86.3	32.12	8.12	32.57	100	298	A	H
		5379.36	47.86	-26.14	74	39.88	32.26	8.29	32.57	100	298	P	H
		5355.36	39.69	-14.31	54	31.81	32.22	8.23	32.57	100	298	A	H
		5098.8	48.65	-25.35	74	41.34	31.92	7.96	32.57	100	243	P	V
		5119.86	40.68	-13.32	54	33.35	31.94	7.96	32.57	100	243	A	V
	*	5270	104.32	-	-	96.65	32.12	8.12	32.57	100	243	P	V
	*	5270	99.06	-	-	91.39	32.12	8.12	32.57	100	243	A	V
		5434.32	50.71	-23.29	74	42.67	32.32	8.29	32.57	100	243	P	V
	5350.8	42.16	-11.84	54	34.28	32.22	8.23	32.57	100	243	A	V	
802.11ac VHT40 CH 62 5310MHz		5105.56	47.58	-26.42	74	40.25	31.94	7.96	32.57	100	296	P	H
		5000	42.27	-11.73	54	34.99	31.8	8.05	32.57	100	296	A	H
	*	5310	101.62	-	-	93.83	32.18	8.18	32.57	100	296	P	H
	*	5310	94.53	-	-	86.74	32.18	8.18	32.57	100	296	A	H
		5352.48	47.92	-26.08	74	40.04	32.22	8.23	32.57	100	296	P	H
		5352.48	41.41	-12.59	54	33.53	32.22	8.23	32.57	100	296	A	H
		5035.62	47.92	-26.08	74	40.63	31.84	8.02	32.57	100	260	P	V
		5000	40.75	-13.25	54	33.47	31.8	8.05	32.57	100	260	A	V
	*	5310	105.17	-	-	97.38	32.18	8.18	32.57	100	260	P	V
	*	5310	99.55	-	-	91.76	32.18	8.18	32.57	100	260	A	V
		5351.52	52.69	-21.31	74	44.81	32.22	8.23	32.57	100	260	P	V
	5350.08	45.22	-8.78	54	37.34	32.22	8.23	32.57	100	260	A	V	
Remark	1. No other spurious found. 2. All results are PASS against Peak and Average limit line.												



Band 2 5250~5350MHz

WIFI 802.11ac VHT40 (Harmonic @ 3m)

WIFI Ant. 1+2	Note	Frequency (MHz)	Level (dBμV/m)	Over Limit (dB)	Limit Line (dBμV/m)	Read Level (dBμV)	Antenna Factor (dB/m)	Cable Loss (dB)	Preamp Factor (dB)	Ant Pos (cm)	Table Pos (deg)	Peak Avg. (P/A)	Pol. (H/V)	
802.11ac VHT40 CH 54 5270MHz		10540	48.59	-25.41	74	47.49	39.93	12.08	50.91	100	0	P	H	
		15810	49.08	-24.92	74	48.61	37.6	14.83	51.96	100	0	P	H	
													H	
													H	
			10540	48.97	-25.03	74	47.87	39.93	12.08	50.91	100	0	P	V
			15810	48.26	-25.74	74	47.79	37.6	14.83	51.96	100	0	P	V
														V
802.11ac VHT40 CH 62 5310MHz		10620	49.98	-24.02	74	48.79	40	12.11	50.92	100	0	P	H	
		15930	48.56	-25.44	74	48.28	37.41	14.86	51.99	100	0	P	H	
													H	
													H	
			10620	49.28	-24.72	74	48.09	40	12.11	50.92	100	0	P	V
			15930	48.12	-25.88	74	47.84	37.41	14.86	51.99	100	0	P	V
														V
Remark	1. No other spurious found.													
	2. All results are PASS against Peak and Average limit line.													



Band 2 5250~5350MHz

WIFI 802.11ac VHT80 (Band Edge @ 3m)

WIFI Ant. 1+2	Note	Frequency (MHz)	Level (dBμV/m)	Over Limit (dB)	Limit Line (dBμV/m)	Read Level (dBμV)	Antenna Factor (dB/m)	Cable Loss (dB)	Preamp Factor (dB)	Ant Pos (cm)	Table Pos (deg)	Peak Avg. (P/A)	Pol. (H/V)
802.11ac VHT80 CH 58 5290MHz		5052	49.18	-24.82	74	41.9	31.86	7.99	32.57	100	299	P	H
		5000	43.69	-10.31	54	36.41	31.8	8.05	32.57	100	299	A	H
	*	5290	101.09	-	-	93.34	32.14	8.18	32.57	100	299	P	H
	*	5290	93.77	-	-	86.02	32.14	8.18	32.57	100	299	A	H
		5357.04	55.47	-18.53	74	47.59	32.22	8.23	32.57	100	299	P	H
		5355.84	48.04	-5.96	54	40.16	32.22	8.23	32.57	100	299	A	H
		5145.86	50.38	-23.62	74	43.03	31.98	7.94	32.57	100	259	P	V
		5150	43.6	-10.4	54	36.25	31.98	7.94	32.57	100	259	A	V
	*	5290	106.34	-	-	98.59	32.14	8.18	32.57	100	259	P	V
	*	5290	99.68	-	-	91.93	32.14	8.18	32.57	100	259	A	V
		5354.4	60.72	-13.28	74	52.84	32.22	8.23	32.57	100	259	P	V
		5350.08	52.75	-1.25	54	44.87	32.22	8.23	32.57	100	259	A	V
Remark	1. No other spurious found. 2. All results are PASS against Peak and Average limit line.												



Band 2 5250~5350MHz

WIFI 802.11ac VHT80 (Harmonic @ 3m)

WIFI Ant. 1+2	Note	Frequency (MHz)	Level (dBμV/m)	Over Limit (dB)	Limit Line (dBμV/m)	Read Level (dBμV)	Antenna Factor (dB/m)	Cable Loss (dB)	Preamp Factor (dB)	Ant Pos (cm)	Table Pos (deg)	Peak Avg. (P/A)	Pol. (H/V)	
802.11ac VHT80 CH 58 5290MHz		10580	48.82	-25.18	74	47.67	39.97	12.1	50.92	100	0	P	H	
		15870	49.18	-24.82	74	48.83	37.49	14.84	51.98	100	0	P	H	
													H	
													H	
			10580	49.41	-24.59	74	48.26	39.97	12.1	50.92	100	0	P	V
			15870	48.3	-25.7	74	47.95	37.49	14.84	51.98	100	0	P	V
														V
													V	
Remark	1. No other spurious found. 2. All results are PASS against Peak and Average limit line.													



Band 3 - 5470~5725MHz

WIFI 802.11a (Band Edge @ 3m)

WIFI Ant. 1+2	Note	Frequency (MHz)	Level (dBμV/m)	Over Limit (dB)	Limit Line (dBμV/m)	Read Level (dBμV)	Antenna Factor (dB/m)	Cable Loss (dB)	Preamp Factor (dB)	Ant Pos (cm)	Table Pos (deg)	Peak Avg. (P/A)	Pol. (H/V)	
802.11a CH 100 5500MHz		5469.36	49.06	-24.94	74	40.98	32.36	8.29	32.57	100	119	P	H	
		5454.8	41.45	-12.55	54	33.39	32.34	8.29	32.57	100	119	A	H	
	*	5500	109.86	-	-	101.74	32.4	8.29	32.57	100	119	P	H	
	*	5500	104.24	-	-	96.12	32.4	8.29	32.57	100	119	A	H	
													H	
													H	
			5454.96	51.89	-22.11	74	43.83	32.34	8.29	32.57	105	210	P	V
			5455.12	46.48	-7.52	54	38.42	32.34	8.29	32.57	150	210	A	V
	*		5498	117.47	-	-	109.35	32.4	8.29	32.57	105	210	P	V
	*		5498	112.1	-	-	103.98	32.4	8.29	32.57	105	210	A	V
													V	
													V	
802.11a CH 116 5580MHz		5458.48	47.59	-26.41	74	39.53	32.34	8.29	32.57	100	123	P	H	
		5459.68	39.9	-14.1	54	31.84	32.34	8.29	32.57	100	123	A	H	
	*	5578	112.49	-	-	104.46	32.44	8.2	32.61	100	123	P	H	
	*	5578	105.38	-	-	97.35	32.44	8.2	32.61	100	123	A	H	
			5762.725	48.61	-25.39	74	40.37	32.56	8.35	32.67	100	123	P	H
			5724.925	39.8	-14.2	54	31.6	32.53	8.33	32.66	100	123	A	H
			5431.12	50.75	-23.25	74	42.71	32.32	8.29	32.57	100	211	P	V
			5440	43.62	-10.38	54	35.58	32.32	8.29	32.57	100	211	A	V
	*		5578	118.2	-	-	110.17	32.44	8.2	32.61	100	211	P	V
	*		5578	111.62	-	-	103.59	32.44	8.2	32.61	100	211	A	V
			5725.275	52.06	-21.94	74	43.86	32.53	8.33	32.66	100	211	P	V
			5759.925	43.39	-10.61	54	35.17	32.56	8.33	32.67	100	211	A	V



802.11a CH 140 5700MHz	*	5698	109.73	-	-	101.57	32.51	8.3	32.65	100	123	P	H
	*	5698	105.24	-	-	97.08	32.51	8.3	32.65	100	123	A	H
		5727.24	53.31	-20.69	74	45.11	32.53	8.33	32.66	100	123	P	H
		5726.68	43.14	-10.86	54	34.94	32.53	8.33	32.66	100	123	A	H
													H
													H
	*	5702	118.6	-	-	110.43	32.52	8.3	32.65	100	241	P	V
	*	5702	112.3	-	-	104.13	32.52	8.3	32.65	100	241	A	V
		5725.32	56.34	-17.66	74	48.14	32.53	8.33	32.66	100	241	P	V
		5725	49.23	-4.77	54	41.03	32.53	8.33	32.66	100	241	A	V
													V
													V
Remark	1. No other spurious found. 2. All results are PASS against Peak and Average limit line.												



Band 3 - 5470~5725MHz

WIFI 802.11a (Harmonic @ 3m)

WIFI Ant. 1+2	Note	Frequency (MHz)	Level (dBμV/m)	Over Limit (dB)	Limit Line (dBμV/m)	Read Level (dBμV)	Antenna Factor (dB/m)	Cable Loss (dB)	Preamp Factor (dB)	Ant Pos (cm)	Table Pos (deg)	Peak Avg. (P/A)	Pol. (H/V)	
802.11a CH 100 5500MHz		11000	50.69	-23.31	74	49.09	40.3	12.3	51	100	0	P	H	
		16500	50.6	-23.4	74	48.57	38.8	15.23	52	100	0	P	H	
													H	
													H	
			11000	50.94	-23.06	74	49.34	40.3	12.3	51	100	0	P	V
			16500	50.04	-23.96	74	48.01	38.8	15.23	52	100	0	P	V
														V
														V
802.11a CH 116 5580MHz		11160	49.26	-24.74	74	47.73	40.2	12.39	51.06	100	0	P	H	
		16740	50.77	-23.23	74	47.95	39.57	15.3	52.05	100	0	P	H	
													H	
													H	
			11160	50.06	-23.94	74	48.53	40.2	12.39	51.06	100	0	P	V
			16740	50.23	-23.77	74	47.41	39.57	15.3	52.05	100	0	P	V
														V
														V
802.11a CH 140 5700MHz		11400	50.71	-23.29	74	49.27	40.06	12.53	51.15	100	0	P	H	
		17100	50.81	-23.19	74	46.77	40.68	15.48	52.12	100	0	P	H	
													H	
													H	
			11400	55.42	-18.58	74	53.98	40.06	12.53	51.15	395	267	P	V
			11400	48.19	-5.81	54	46.75	40.06	12.53	51.15	395	267	A	V
			17100	50.03	-23.97	74	45.99	40.68	15.48	52.12	100	0	P	V
														V
Remark	1. No other spurious found. 2. All results are PASS against Peak and Average limit line.													



Band 3 - 5470~5725MHz

WIFI 802.11ac VHT20 (Band Edge @ 3m)

WIFI Ant. 1+2	Note	Frequency (MHz)	Level (dBμV/m)	Over Limit (dB)	Limit Line (dBμV/m)	Read Level (dBμV)	Antenna Factor (dB/m)	Cable Loss (dB)	Preamp Factor (dB)	Ant Pos (cm)	Table Pos (deg)	Peak Avg. (P/A)	Pol. (H/V)	
802.11ac VHT20 CH 100 5500MHz		5461.52	48.23	-25.77	74	40.17	32.34	8.29	32.57	100	302	P	H	
		5468.72	39.27	-14.73	54	31.19	32.36	8.29	32.57	100	302	A	H	
	*	5498	99.95	-	-	91.83	32.4	8.29	32.57	100	302	P	H	
	*	5498	92.43	-	-	84.31	32.4	8.29	32.57	100	302	A	H	
													H	
														H
			5370.32	49.21	-24.79	74	41.25	32.24	8.29	32.57	114	311	P	V
			5468.72	41.73	-12.27	54	33.65	32.36	8.29	32.57	114	311	A	V
		*	5498	106.92	-	-	98.8	32.4	8.29	32.57	114	311	P	V
		*	5498	99.64	-	-	91.52	32.4	8.29	32.57	114	311	A	V
													V	
													V	
802.11ac VHT20 CH 116 5580MHz		5424.88	46.52	-27.48	74	38.5	32.3	8.29	32.57	100	212	P	H	
		5465.92	38.42	-15.58	54	30.34	32.36	8.29	32.57	100	212	A	H	
		*	5578	97.64	-	-	89.61	32.44	8.2	32.61	100	212	P	H
		*	5578	90.95	-	-	82.92	32.44	8.2	32.61	100	212	A	H
			5743.3	47.1	-26.9	74	38.9	32.54	8.33	32.67	100	212	P	H
			5760.275	39.04	-14.96	54	30.82	32.56	8.33	32.67	100	212	A	H
			5429.68	47.79	-26.21	74	39.75	32.32	8.29	32.57	100	216	P	V
			5440	39.24	-14.76	54	31.2	32.32	8.29	32.57	100	216	A	V
		*	5580	104.58	-	-	96.55	32.44	8.2	32.61	100	216	P	V
		*	5580	100.17	-	-	92.14	32.44	8.2	32.61	100	216	A	V
		5751.525	48.84	-25.16	74	40.62	32.56	8.33	32.67	100	216	P	V	
		5759.925	41.38	-12.62	54	33.16	32.56	8.33	32.67	100	216	A	V	



802.11ac VHT20 CH 140 5700MHz	*	5702	98.14	-	-	89.97	32.52	8.3	32.65	100	211	P	H
	*	5702	91.05	-	-	82.88	32.52	8.3	32.65	100	211	A	H
		5760.76	48.07	-25.93	74	39.85	32.56	8.33	32.67	100	211	P	H
		5726.36	39.57	-14.43	54	31.37	32.53	8.33	32.66	100	211	A	H
													H
													H
	*	5700	105.5	-	-	97.34	32.51	8.3	32.65	100	310	P	V
	*	5700	99.13	-	-	90.97	32.51	8.3	32.65	100	310	A	V
		5731.8	51.3	-22.7	74	43.11	32.53	8.33	32.67	100	310	P	V
		5725	42.47	-11.53	54	34.27	32.53	8.33	32.66	100	310	A	V
													V
													V
Remark	1. No other spurious found. 2. All results are PASS against Peak and Average limit line.												



Band 3 - 5470~5725MHz

WIFI 802.11ac VHT20 (Harmonic @ 3m)

WIFI Ant. 1+2	Note	Frequency (MHz)	Level (dBμV/m)	Over Limit (dB)	Limit Line (dBμV/m)	Read Level (dBμV)	Antenna Factor (dB/m)	Cable Loss (dB)	Preamp Factor (dB)	Ant Pos (cm)	Table Pos (deg)	Peak Avg. (P/A)	Pol. (H/V)	
802.11ac VHT20 CH 100 5500MHz		11000	49.64	-24.36	74	48.04	40.3	12.3	51	100	0	P	H	
		16500	49.89	-24.11	74	47.86	38.8	15.23	52	100	0	P	H	
													H	
													H	
			11000	50.45	-23.55	74	48.85	40.3	12.3	51	100	0	P	V
			16500	49.9	-24.1	74	47.87	38.8	15.23	52	100	0	P	V
														V
802.11ac VHT20 CH 116 5580MHz		11160	50.69	-23.31	74	49.16	40.2	12.39	51.06	100	0	P	H	
		16740	50.16	-23.84	74	47.34	39.57	15.3	52.05	100	0	P	H	
													H	
													H	
			11160	50.4	-23.6	74	48.87	40.2	12.39	51.06	100	0	P	V
			16740	50.9	-23.1	74	48.08	39.57	15.3	52.05	100	0	P	V
														V
802.11ac VHT20 CH 140 5700MHz		11400	49.6	-24.4	74	48.16	40.06	12.53	51.15	100	0	P	H	
		17100	50.48	-23.52	74	46.44	40.68	15.48	52.12	100	0	P	H	
													H	
													H	
			11400	50.15	-23.85	74	48.71	40.06	12.53	51.15	100	0	P	V
			17100	50.71	-23.29	74	46.67	40.68	15.48	52.12	100	0	P	V
														V
Remark	1. No other spurious found.													
	2. All results are PASS against Peak and Average limit line.													



Band 3 - 5470~5725MHz

WIFI 802.11ac VHT40 (Band Edge @ 3m)

WIFI Ant. 1+2	Note	Frequency (MHz)	Level (dBμV/m)	Over Limit (dB)	Limit Line (dBμV/m)	Read Level (dBμV)	Antenna Factor (dB/m)	Cable Loss (dB)	Preamp Factor (dB)	Ant Pos (cm)	Table Pos (deg)	Peak Avg. (P/A)	Pol. (H/V)
802.11ac VHT40 CH 102 5510MHz		5466.4	48.27	-25.73	74	40.19	32.36	8.29	32.57	100	299	P	H
		5467.12	41.53	-12.47	54	33.45	32.36	8.29	32.57	100	299	A	H
	*	5512	99.81	-	-	91.7	32.4	8.29	32.58	100	299	P	H
	*	5512	92.85	-	-	84.74	32.4	8.29	32.58	100	299	A	H
		5738.575	48.14	-25.86	74	39.94	32.54	8.33	32.67	100	299	P	H
		5754.675	38.85	-15.15	54	30.63	32.56	8.33	32.67	100	299	A	H
		5469.76	51.43	-22.57	74	43.35	32.36	8.29	32.57	100	209	P	V
		5469.52	44.66	-9.34	54	36.58	32.36	8.29	32.57	100	209	A	V
	*	5512	105.01	-	-	96.9	32.4	8.29	32.58	100	209	P	V
	*	5512	99.06	-	-	90.95	32.4	8.29	32.58	100	209	A	V
		5759.575	50.18	-23.82	74	41.96	32.56	8.33	32.67	100	209	P	V
	5759.925	41.55	-12.45	54	33.33	32.56	8.33	32.67	100	209	A	V	
802.11ac VHT40 CH 110 5550MHz		5420.08	47.34	-26.66	74	39.32	32.3	8.29	32.57	100	302	P	H
		5467.36	39.14	-14.86	54	31.06	32.36	8.29	32.57	100	302	A	H
	*	5550	98.09	-	-	90.01	32.43	8.24	32.59	100	302	P	H
	*	5550	90.87	-	-	82.79	32.43	8.24	32.59	100	302	A	H
		5761.15	47.76	-26.24	74	39.54	32.56	8.33	32.67	100	302	P	H
		5750.475	38.53	-15.47	54	30.33	32.54	8.33	32.67	100	302	A	H
		5468.32	48.96	-25.04	74	40.88	32.36	8.29	32.57	100	214	P	V
		5468.32	41.08	-12.92	54	33	32.36	8.29	32.57	100	214	A	V
	*	5550	104.41	-	-	96.33	32.43	8.24	32.59	100	214	P	V
	*	5550	97.48	-	-	89.4	32.43	8.24	32.59	100	214	A	V
		5742.95	49.95	-24.05	74	41.75	32.54	8.33	32.67	100	214	P	V
	5759.925	42.6	-11.4	54	34.38	32.56	8.33	32.67	100	214	A	V	



802.11ac VHT40 CH 134 5670MHz		5430.64	46.87	-27.13	74	38.83	32.32	8.29	32.57	100	210	P	H
		5445.52	38.73	-15.27	54	30.67	32.34	8.29	32.57	100	210	A	H
	*	5668	98.8	-	-	90.67	32.5	8.27	32.64	100	210	P	H
	*	5668	91.58	-	-	83.45	32.5	8.27	32.64	100	210	A	H
		5735.075	49.07	-24.93	74	40.87	32.54	8.33	32.67	100	210	P	H
		5725.45	39.79	-14.21	54	31.59	32.53	8.33	32.66	100	210	A	H
		5353.84	47.59	-26.41	74	39.71	32.22	8.23	32.57	100	117	P	V
		5465.92	39.67	-14.33	54	31.59	32.36	8.29	32.57	100	117	A	V
	*	5672	108.51	-	-	100.38	32.5	8.27	32.64	100	117	P	V
	*	5672	98.98	-	-	90.85	32.5	8.27	32.64	100	117	A	V
		5760.275	51.92	-22.08	74	43.7	32.56	8.33	32.67	100	117	P	V
		5759.925	43.77	-10.23	54	35.55	32.56	8.33	32.67	100	117	A	V
Remark	1. No other spurious found. 2. All results are PASS against Peak and Average limit line.												



Band 3 - 5470~5725MHz

WIFI 802.11ac VHT40 (Harmonic @ 3m)

WIFI Ant. 1+2	Note	Frequency (MHz)	Level (dBμV/m)	Over Limit (dB)	Limit Line (dBμV/m)	Read Level (dBμV)	Antenna Factor (dB/m)	Cable Loss (dB)	Preamp Factor (dB)	Ant Pos (cm)	Table Pos (deg)	Peak Avg. (P/A)	Pol. (H/V)	
802.11ac VHT40 CH 102 5510MHz		11020	50.15	-23.85	74	48.56	40.29	12.3	51	100	0	P	H	
		16530	49.96	-24.04	74	47.81	38.91	15.24	52	100	0	P	H	
													H	
													H	
			11020	50.16	-23.84	74	48.57	40.29	12.3	51	100	0	P	V
			16530	50.41	-23.59	74	48.26	38.91	15.24	52	100	0	P	V
														V
802.11ac VHT40 CH 110 5550MHz		11100	49.23	-24.77	74	47.67	40.24	12.35	51.03	100	0	P	H	
		16650	50.43	-23.57	74	47.88	39.3	15.28	52.03	100	0	P	H	
													H	
													H	
			11100	50.96	-23.04	74	49.4	40.24	12.35	51.03	100	0	P	V
			16650	50.53	-23.47	74	47.98	39.3	15.28	52.03	100	0	P	V
														V
802.11ac VHT40 CH 134 5670MHz		11340	50.02	-23.98	74	48.57	40.1	12.49	51.14	100	0	P	H	
		17010	50.66	-23.34	74	46.92	40.45	15.39	52.1	100	0	P	H	
													H	
													H	
			11340	50.79	-23.21	74	49.34	40.1	12.49	51.14	100	0	P	V
			17010	50.36	-23.64	74	46.62	40.45	15.39	52.1	100	0	P	V
														V
Remark	1. No other spurious found.													
	2. All results are PASS against Peak and Average limit line.													



Band 3 5470~5725MHz

WIFI 802.11ac VHT80 (Band Edge @ 3m)

WIFI Ant. 1+2	Note	Frequency (MHz)	Level (dBμV/m)	Over Limit (dB)	Limit Line (dBμV/m)	Read Level (dBμV)	Antenna Factor (dB/m)	Cable Loss (dB)	Preamp Factor (dB)	Ant Pos (cm)	Table Pos (deg)	Peak Avg. (P/A)	Pol. (H/V)
802.11ac VHT80 CH 106 5530MHz		5450.32	50.36	-23.64	74	42.3	32.34	8.29	32.57	100	297	P	H
		5467.12	45.11	-8.89	54	37.03	32.36	8.29	32.57	100	297	A	H
	*	5518	99.5	-	-	91.38	32.41	8.29	32.58	100	297	P	H
	*	5518	91.78	-	-	83.66	32.41	8.29	32.58	100	297	A	H
		5755.55	48.37	-25.63	74	40.15	32.56	8.33	32.67	100	297	P	H
		5750.125	39.79	-14.21	54	31.59	32.54	8.33	32.67	100	297	A	H
		5464.48	55.94	-18.06	74	47.86	32.36	8.29	32.57	100	211	P	V
		5450.8	51.48	-2.52	54	43.42	32.34	8.29	32.57	100	211	A	V
	*	5530	105.59	-	-	97.53	32.41	8.24	32.59	100	211	P	V
	*	5530	97.81	-	-	89.75	32.41	8.24	32.59	100	211	A	V
		5737	51.26	-22.74	74	43.06	32.54	8.33	32.67	100	211	P	V
	5759.925	43.77	-10.23	54	35.55	32.56	8.33	32.67	100	211	A	V	
802.11ac VHT80 CH 122 5610MHz		5466.4	49.06	-24.94	74	40.98	32.36	8.29	32.57	100	300	P	H
		5464	41.62	-12.38	54	33.54	32.36	8.29	32.57	100	300	A	H
	*	5608	97.19	-	-	89.12	32.46	8.23	32.62	100	300	P	H
	*	5608	90.88	-	-	82.81	32.46	8.23	32.62	100	300	A	H
		5744.7	49.18	-24.82	74	40.98	32.54	8.33	32.67	100	300	P	H
		5732.45	41.51	-12.49	54	33.32	32.53	8.33	32.67	100	300	A	H
		5468.08	52.07	-21.93	74	43.99	32.36	8.29	32.57	100	313	P	V
		5440	45.07	-8.93	54	37.03	32.32	8.29	32.57	100	313	A	V
	*	5610	107.03	-	-	98.96	32.46	8.23	32.62	100	313	P	V
	*	5610	97.69	-	-	89.62	32.46	8.23	32.62	100	313	A	V
		5727.025	55.44	-18.56	74	47.24	32.53	8.33	32.66	100	313	P	V
	5730.875	47.97	-6.03	54	39.78	32.53	8.33	32.67	100	313	A	V	
Remark	1. No other spurious found. 2. All results are PASS against Peak and Average limit line.												



Band 3 5470~5725MHz

WIFI 802.11ac VHT80 (Harmonic @ 3m)

WIFI Ant. 1+2	Note	Frequency (MHz)	Level (dBμV/m)	Over Limit (dB)	Limit Line (dBμV/m)	Read Level (dBμV)	Antenna Factor (dB/m)	Cable Loss (dB)	Preamp Factor (dB)	Ant Pos (cm)	Table Pos (deg)	Peak Avg. (P/A)	Pol. (H/V)	
802.11ac VHT80 CH 106 5530MHz		11060	50.98	-23.02	74	49.42	40.26	12.32	51.02	100	0	P	H	
		16590	50.99	-23.01	74	48.67	39.08	15.26	52.02	100	0	P	H	
													H	
													H	
			11060	50.47	-23.53	74	48.91	40.26	12.32	51.02	100	0	P	V
			16590	50.73	-23.27	74	48.41	39.08	15.26	52.02	100	0	P	V
														V
802.11ac VHT80 CH 122 5610MHz		11220	49.45	-24.55	74	47.95	40.17	12.42	51.09	100	0	P	H	
		16830	50.49	-23.51	74	47.37	39.85	15.33	52.06	100	0	P	H	
													H	
													H	
			11220	50.16	-23.84	74	48.66	40.17	12.42	51.09	100	0	P	V
			16830	50.34	-23.66	74	47.22	39.85	15.33	52.06	100	0	P	V
														V
Remark	1. No other spurious found.													
	2. All results are PASS against Peak and Average limit line.													



Band 3 - Straddle Channel

WIFI 802.11a (Fundamental @ 3m)

WIFI Ant. 1+2	Note	Frequency (MHz)	Level (dBµV/m)	Over Limit (dB)	Limit Line (dBµV/m)	Read Level (dBµV)	Antenna Factor (dB/m)	Cable Loss (dB)	Preamp Factor (dB)	Ant Pos (cm)	Table Pos (deg)	Peak Avg. (P/A)	Pol. (H/V)
802.11a CH 144 5720MHz	*	5722	108.08	-	-	99.88	32.53	8.33	32.66	100	215	P	H
	*	5722	100.76	-	-	92.56	32.53	8.33	32.66	100	215	A	H
													H
													H
													H
													H
	*	5722	114.75	-	-	106.55	32.53	8.33	32.66	100	218	P	V
	*	5722	107.63	-	-	99.43	32.53	8.33	32.66	100	218	A	V
													V
													V
													V
													V
Remark	1. No other spurious found. 2. All results are PASS against Peak and Average limit line.												



Band 3 - Straddle Channel

WIFI 802.11a (Harmonic @ 3m)

WIFI Ant. 1+2	Note	Frequency (MHz)	Level (dBμV/m)	Over Limit (dB)	Limit Line (dBμV/m)	Read Level (dBμV)	Antenna Factor (dB/m)	Cable Loss (dB)	Preamp Factor (dB)	Ant Pos (cm)	Table Pos (deg)	Peak Avg. (P/A)	Pol. (H/V)	
802.11a CH 144 5720MHz		11440	49.8	-24.2	74	48.37	40.04	12.56	51.17	100	0	P	H	
		17160	50.93	-23.07	74	46.62	40.87	15.57	52.13	100	0	P	H	
													H	
													H	
			11440	50.21	-23.79	74	48.78	40.04	12.56	51.17	100	0	P	V
			17160	50.76	-23.24	74	46.45	40.87	15.57	52.13	100	0	P	V
														V
														V
Remark	1. No other spurious found. 2. All results are PASS against Peak and Average limit line.													



Band 3 - Straddle Channel

WIFI 802.11ac VHT20 (Fundamental @ 3m)

WIFI Ant. 1+2	Note	Frequency (MHz)	Level (dBμV/m)	Over Limit (dB)	Limit Line (dBμV/m)	Read Level (dBμV)	Antenna Factor (dB/m)	Cable Loss (dB)	Preamp Factor (dB)	Ant Pos (cm)	Table Pos (deg)	Peak Avg. (P/A)	Pol. (H/V)
802.11ac VHT20 CH 144 5720MHz	*	5722	98.9	-	-	90.7	32.53	8.33	32.66	100	214	P	H
	*	5722	90.16	-	-	81.96	32.53	8.33	32.66	100	214	A	H
													H
													H
													H
													H
	*	5718	106.31	-	-	98.14	32.53	8.3	32.66	100	311	P	V
	*	5718	99.61	-	-	91.44	32.53	8.3	32.66	100	311	A	V
													V
													V
Remark	1. No other spurious found. 2. All results are PASS against Peak and Average limit line.												



Band 3 - Straddle Channel

WIFI 802.11ac VHT20 (Harmonic @ 3m)

WIFI Ant. 1+2	Note	Frequency (MHz)	Level (dBμV/m)	Over Limit (dB)	Limit Line (dBμV/m)	Read Level (dBμV)	Antenna Factor (dB/m)	Cable Loss (dB)	Preamp Factor (dB)	Ant Pos (cm)	Table Pos (deg)	Peak Avg. (P/A)	Pol. (H/V)	
802.11ac VHT20 CH 144 5720MHz		11440	50.42	-23.58	74	48.99	40.04	12.56	51.17	100	0	P	H	
		17160	50.01	-23.99	74	45.7	40.87	15.57	52.13	100	0	P	H	
													H	
													H	
			11440	49.91	-24.09	74	48.48	40.04	12.56	51.17	100	0	P	V
			17160	50.24	-23.76	74	45.93	40.87	15.57	52.13	100	0	P	V
														V
													V	
Remark	1. No other spurious found. 2. All results are PASS against Peak and Average limit line.													



Band 3 - Straddle Channel

WIFI 802.11ac VHT40 (Fundamental @ 3m)

WIFI Ant. 1+2	Note	Frequency (MHz)	Level (dBµV/m)	Over Limit (dB)	Limit Line (dBµV/m)	Read Level (dBµV)	Antenna Factor (dB/m)	Cable Loss (dB)	Preamp Factor (dB)	Ant Pos (cm)	Table Pos (deg)	Peak Avg. (P/A)	Pol. (H/V)
802.11ac VHT40 CH 142 5710MHz	*	5712	98.26	-	-	90.1	32.52	8.3	32.66	100	216	P	H
	*	5712	91.29	-	-	83.13	32.52	8.3	32.66	100	216	A	H
													H
													H
													H
													H
	*	5708	107.73	-	-	99.57	32.52	8.3	32.66	100	121	P	V
	*	5708	98.73	-	-	90.57	32.52	8.3	32.66	100	121	A	V
													V
													V
													V
													V
Remark	1. No other spurious found. 2. All results are PASS against Peak and Average limit line.												



Band 3 - Straddle Channel

WIFI 802.11ac VHT40 (Harmonic @ 3m)

WIFI Ant. 1+2	Note	Frequency (MHz)	Level (dBμV/m)	Over Limit (dB)	Limit Line (dBμV/m)	Read Level (dBμV)	Antenna Factor (dB/m)	Cable Loss (dB)	Preamp Factor (dB)	Ant Pos (cm)	Table Pos (deg)	Peak Avg. (P/A)	Pol. (H/V)	
802.11ac VHT40 CH 142 5710MHz		11420	50.19	-23.81	74	48.78	40.05	12.53	51.17	100	0	P	H	
		17130	50.77	-23.23	74	46.6	40.77	15.52	52.12	100	0	P	H	
													H	
													H	
			11420	49.7	-24.3	74	48.29	40.05	12.53	51.17	100	0	P	V
			17130	50.64	-23.36	74	46.47	40.77	15.52	52.12	100	0	P	V
														V
													V	
Remark	1. No other spurious found. 2. All results are PASS against Peak and Average limit line.													



Band 3 - Straddle Channel

WIFI 802.11ac VHT80 (Fundamental @ 3m)

WIFI Ant. 1+2	Note	Frequency (MHz)	Level (dBμV/m)	Over Limit (dB)	Limit Line (dBμV/m)	Read Level (dBμV)	Antenna Factor (dB/m)	Cable Loss (dB)	Preamp Factor (dB)	Ant Pos (cm)	Table Pos (deg)	Peak Avg. (P/A)	Pol. (H/V)
802.11ac VHT80 CH 138 5690MHz	*	5688	97.64	-	-	89.48	32.51	8.3	32.65	100	316	P	H
	*	5688	90.14	-	-	81.98	32.51	8.3	32.65	100	316	A	H
													H
													H
													H
													H
	*	5692	106.58	-	-	98.42	32.51	8.3	32.65	100	311	P	V
	*	5692	97.94	-	-	89.78	32.51	8.3	32.65	100	311	A	V
													V
													V
Remark	1. No other spurious found. 2. All results are PASS against Peak and Average limit line.												



Band 3 - Straddle Channel

WIFI 802.11ac VHT80 (Harmonic @ 3m)

WIFI Ant. 1+2	Note	Frequency (MHz)	Level (dBμV/m)	Over Limit (dB)	Limit Line (dBμV/m)	Read Level (dBμV)	Antenna Factor (dB/m)	Cable Loss (dB)	Preamp Factor (dB)	Ant Pos (cm)	Table Pos (deg)	Peak Avg. (P/A)	Pol. (H/V)	
802.11ac VHT80 CH 138 5690MHz		11380	49.97	-24.03	74	48.54	40.07	12.51	51.15	100	0	P	H	
		17070	50.3	-23.7	74	46.4	40.59	15.43	52.12	100	0	P	H	
													H	
													H	
			11380	50.38	-23.62	74	48.95	40.07	12.51	51.15	100	0	P	V
			17070	50.09	-23.91	74	46.19	40.59	15.43	52.12	100	0	P	V
														V
Remark	1. No other spurious found. 2. All results are PASS against Peak and Average limit line.													



Emission below 1GHz

WIFI 802.11a (LF @ 3m)

WIFI Ant. 1+2	Note	Frequency (MHz)	Level (dBμV/m)	Over Limit (dB)	Limit Line (dBμV/m)	Read Level (dBμV)	Antenna Factor (dB/m)	Cable Loss (dB)	Preamp Factor (dB)	Ant Pos (cm)	Table Pos (deg)	Peak Avg. (P/A)	Pol. (H/V)	
802.11a LF		69.96	32.55	-7.45	40	51.74	12.6	0.93	32.72	-	-	P	H	
		171.21	35.46	-8.04	43.5	50.61	16.07	1.48	32.7	-	-	P	H	
		278.4	41.18	-4.82	46	52.83	19.32	1.76	32.73	100	0	P	H	
		323.1	31.68	-14.32	46	42.17	20.39	1.88	32.76	-	-	P	H	
		371.4	34.57	-11.43	46	43.53	21.72	2.13	32.81	-	-	P	H	
		650	37.83	-8.17	46	42.17	26	2.67	33.01	-	-	P	H	
														H
														H
														H
														H
														H
														H
			32.16	34.98	-5.02	40	42.17	24.98	0.65	32.82	-	-	P	V
			42.15	36.75	-3.25	40	50.08	18.82	0.65	32.8	100	0	P	V
			278.4	40.71	-5.29	46	52.36	19.32	1.76	32.73	-	-	P	V
			370	37.41	-8.59	46	46.4	21.69	2.13	32.81	-	-	P	V
			596.8	29.78	-16.22	46	34.82	25.42	2.57	33.03	-	-	P	V
			650	34.52	-11.48	46	38.86	26	2.67	33.01	-	-	P	V
														V
														V
													V	
													V	
													V	
													V	
Remark	1. No other spurious found. 2. All results are PASS against limit line.													



Emission below 1GHz

WIFI 802.11ac VHT20 (LF @ 3m)

WIFI Ant. 1+2	Note	Frequency (MHz)	Level (dBμV/m)	Over Limit (dB)	Limit Line (dBμV/m)	Read Level (dBμV)	Antenna Factor (dB/m)	Cable Loss (dB)	Preamp Factor (dB)	Ant Pos (cm)	Table Pos (deg)	Peak Avg. (P/A)	Pol. (H/V)	
802.11ac VHT20 LF		65.91	36.53	-3.47	40	55.97	12.36	0.93	32.73	100	0	P	H	
		146.1	38.8	-4.7	43.5	52.34	17.81	1.33	32.68	-	-	P	H	
		232.23	42.17	-3.83	46	56.1	17.18	1.62	32.73	-	-	P	H	
		316.1	39.25	-6.75	46	49.93	20.19	1.88	32.75	-	-	P	H	
		460.3	36.2	-9.8	46	43.38	23.41	2.3	32.89	-	-	P	H	
		650	38.65	-7.35	46	42.99	26	2.67	33.01	-	-	P	H	
														H
														H
														H
														H
														H
														H
			34.05	37.12	-2.88	40	45.42	23.86	0.65	32.81	100	1	QP	V
			49.98	38.51	-1.49	40	55.16	15.2	0.93	32.78	100	56	QP	V
			65.65	37.23	-2.77	40	56.67	12.36	0.93	32.73	183	27	QP	V
			308.4	32.66	-13.34	46	43.56	19.96	1.88	32.74	-	-	P	V
			650	35.32	-10.68	46	39.66	26	2.67	33.01	-	-	P	V
		974.8	50.64	-3.36	54	48.75	30	3.38	31.49	-	-	P	V	
													V	
													V	
													V	
Remark	3. No other spurious found. 4. All results are PASS against limit line.													



Emission below 1GHz

WIFI 802.11ac VHT40 (LF @ 3m)

WIFI Ant. 1+2	Note	Frequency (MHz)	Level (dBμV/m)	Over Limit (dB)	Limit Line (dBμV/m)	Read Level (dBμV)	Antenna Factor (dB/m)	Cable Loss (dB)	Preamp Factor (dB)	Ant Pos (cm)	Table Pos (deg)	Peak Avg. (P/A)	Pol. (H/V)	
802.11ac VHT40 LF		65.1	36.84	-3.16	40	56.35	12.3	0.93	32.74	-	-	P	H	
		93.18	36.96	-6.54	43.5	52.98	15.49	1.14	32.65	-	-	P	H	
		278.67	43	-3	46	54.65	19.32	1.76	32.73	100	0	P	H	
		301.4	37.73	-8.27	46	48.82	19.76	1.88	32.73	-	-	P	H	
		487.6	35.47	-10.53	46	42.1	23.95	2.33	32.91	-	-	P	H	
		650	39.54	-6.46	46	43.88	26	2.67	33.01	-	-	P	H	
														H
														H
														H
														H
														H
														H
			38.68	37.03	-2.97	40	48.12	21.06	0.65	32.8	100	0	QP	V
			49.44	38.6	-1.4	40	54.83	15.62	0.93	32.78	100	19	QP	V
			64.83	36.58	-3.42	40	56.09	12.3	0.93	32.74	152	31	QP	V
			407.8	32.75	-13.25	46	40.92	22.52	2.16	32.85	-	-	P	V
			650	35.61	-10.39	46	39.95	26	2.67	33.01	-	-	P	V
			974.8	47.34	-6.66	54	45.45	30	3.38	31.49	-	-	P	V
														V
														V
													V	
Remark	1. No other spurious found. 2. All results are PASS against limit line.													



Emission below 1GHz

WIFI 802.11ac VHT80 (LF @ 3m)

WIFI Ant. 1+2	Note	Frequency (MHz)	Level (dBμV/m)	Over Limit (dB)	Limit Line (dBμV/m)	Read Level (dBμV)	Antenna Factor (dB/m)	Cable Loss (dB)	Preamp Factor (dB)	Ant Pos (cm)	Table Pos (deg)	Peak Avg. (P/A)	Pol. (H/V)	
802.11ac VHT80 LF		105.06	37.48	-6.02	43.5	52.13	16.85	1.14	32.64	-	-	P	H	
		231.42	42.11	-3.89	46	56.04	17.18	1.62	32.73	-	-	P	H	
		278.4	42.77	-3.23	46	54.42	19.32	1.76	32.73	100	0	P	H	
		301.4	37.63	-8.37	46	48.72	19.76	1.88	32.73	-	-	P	H	
		650	38.14	-7.86	46	42.48	26	2.67	33.01	-	-	P	H	
		874.7	35.74	-10.26	46	36.33	28.7	3.16	32.45	-	-	P	H	
														H
														H
														H
														H
														H
														H
			34.099	37.06	-2.94	40	45.36	23.86	0.65	32.81	100	0	QP	V
			45.39	37.73	-2.27	40	52.31	17.28	0.93	32.79	100	15	QP	V
			62.48	36.74	-3.26	40	56.43	12.12	0.93	32.74	138	100	QP	V
			509.3	31.92	-14.08	46	38.27	24.25	2.33	32.93	-	-	P	V
			650	35.77	-10.23	46	40.11	26	2.67	33.01	-	-	P	V
		974.8	48.78	-5.22	54	46.89	30	3.38	31.49	-	-	P	V	
													V	
													V	
													V	
Remark	1. No other spurious found. 2. All results are PASS against limit line.													



Note symbol

*	Fundamental Frequency which can be ignored. However, the level of any unwanted emissions shall not exceed the level of the fundamental frequency.
!	Test result is over limit line.
P/A	Peak or Average
H/V	Horizontal or Vertical



A calculation example for radiated spurious emission is shown as below:

WIFI Ant. 1+2	Note	Frequency (MHz)	Level (dBμV/m)	Over Limit (dB)	Limit Line (dBμV/m)	Read Level (dBμV)	Antenna Factor (dB/m)	Cable Loss (dB)	Preamp Factor (dB)	Ant Pos (cm)	Table Pos (deg)	Peak Avg. (P/A)	Pol. (H/V)
802.11b CH 01 2412MHz		2390	55.45	-18.55	74	54.51	32.22	4.58	35.86	103	308	P	H
		2390	43.54	-10.46	54	42.6	32.22	4.58	35.86	103	308	A	H

- Level(dBμV/m) =
Antenna Factor(dB/m) + Cable Loss(dB) + Read Level(dBμV) - Preamp Factor(dB)
- Over Limit(dB) = Level(dBμV/m) – Limit Line(dBμV/m)

For Peak Limit @ 2390MHz:

- Level(dBμV/m)
= Antenna Factor(dB/m) + Cable Loss(dB) + Read Level(dBμV) - Preamp Factor(dB)
= 32.22(dB/m) + 4.58(dB) + 54.51(dBμV) – 35.86 (dB)
= 55.45 (dBμV/m)
- Over Limit(dB)
= Level(dBμV/m) – Limit Line(dBμV/m)
= 55.45(dBμV/m) – 74(dBμV/m)
= -18.55(dB)

For Average Limit @ 2390MHz:

- Level(dBμV/m)
= Antenna Factor(dB/m) + Cable Loss(dB) + Read Level(dBμV) - Preamp Factor(dB)
= 32.22(dB/m) + 4.58(dB) + 42.6(dBμV) – 35.86 (dB)
= 43.54 (dBμV/m)
- Over Limit(dB)
= Level(dBμV/m) – Limit Line(dBμV/m)
= 43.54(dBμV/m) – 54(dBμV/m)
= -10.46(dB)

Both peak and average measured complies with the limit line, so test result is “PASS”.



Appendix C. Radiated Spurious Emission

Test Engineer :	Tsung Lee, Stan Hsieh and Wilson Wu	Temperature :	25~26°C
		Relative Humidity :	48~49%

Note symbol

-L	Low channel location
-R	High channel location



Band 2 - 5250~5350MHz
WIFI 802.11a (Band Edge @ 3m)

WIFI	Band 2 5250~5350MHz Band Edge @ 3m	
ANT	802.11a CH52 5260MHz - L	
1+2	Horizontal	Fundamental
Peak		
Avg.		Left blank



WIFI	Band 2 5250~5350MHz Band Edge @ 3m	
ANT	802.11a CH52 5260MHz - R	
1+2	Horizontal	Fundamental
Peak	<p>Site : 03CH10-HY Condition : FCC CLASS-B 3m HORN 9120D-HF HORIZONTAL RBW:1000.000kHz VBW:3000.000kHz SWT:Auto Detector : Peak Project : 652049-01 Mode : 1</p>	Left blank
Avg.	<p>Site : 03CH10-HY Condition : FCC CLASS-B (AVG) 3m HORN 9120D-HF HORIZONTAL RBW:1000.000kHz VBW:10000-hz SWT:Auto Detector : Peak Project : 652049-01 Mode : 1</p>	Left blank

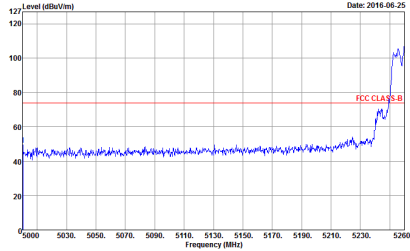
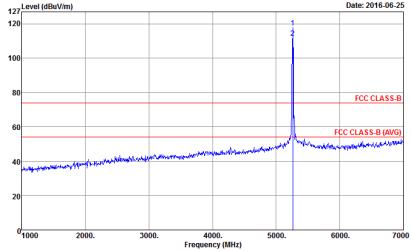
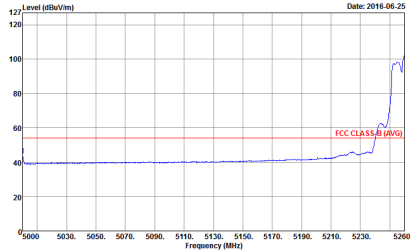

WIFI	Band 2 5250~5350MHz Band Edge @ 3m	
ANT	802.11a CH52 5260MHz - L	
1+2	Vertical	Fundamental
Peak	 <p>Site : 03CH10-HY Condition : FCC CLASS-B 3m HORN 9120D-HF VERTICAL RBW:1000.000KHz VBW:3000.000KHz SWT:Auto Detector : Peak Project : 652049-01 Mode : 1</p>	 <p>Site : 03CH10-HY Condition : FCC CLASS-B 3m HORN 9120D-HF VERTICAL RBW:1000.000KHz VBW:3000.000KHz SWT:Auto Detector : Peak Project : 652049-01 Mode : 1</p>
Avg.	 <p>Site : 03CH10-HY Condition : FCC CLASS-B (AVG) 3m HORN 9120D-HF VERTICAL RBW:1000.000KHz VBW:1000KHz SWT:Auto Detector : Peak Project : 652049-01 Mode : 1</p>	Left blank

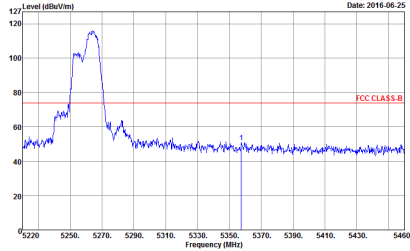
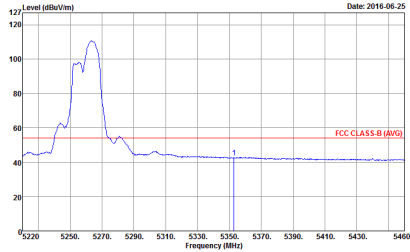

WIFI	Band 2 5250~5350MHz Band Edge @ 3m	
ANT	802.11a CH52 5260MHz - R	
1+2	Vertical	Fundamental
Peak	 <p>Site : 03CH10-HY Condition : FCC CLASS-B 3m HORN 9120D-HF VERTICAL RBW:1000.000KHz VBW:3000.000KHz SWT:Auto Detector : Peak Project : 652049-01 Mode : 1</p>	Left blank
Avg.	 <p>Site : 03CH10-HY Condition : FCC CLASS-B (AVG) 3m HORN 9120D-HF VERTICAL RBW:1000.000KHz VBW:1000KHz SWT:Auto Detector : Peak Project : 652049-01 Mode : 1</p>	Left blank

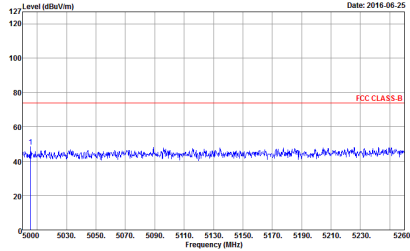
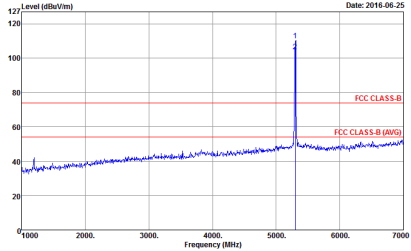
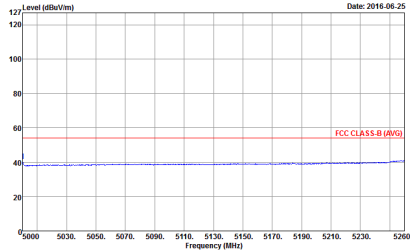

WIFI	Band 2 5250~5350MHz Band Edge @ 3m	
ANT	802.11a CH60 5300MHz - L	
1+2	Horizontal	Fundamental
Peak	 <p>Date: 2016-06-25</p> <p>Site : 03CH10-HY Condition : FCC CLASS-B 3m HORN 9120D-HF HORIZONTAL RBW:1000.000KHz VBW:3000.000KHz SWT:Auto Detector : Peak Project : 652049-01 Mode : 2</p>	 <p>Date: 2016-06-25</p> <p>Site : 03CH10-HY Condition : FCC CLASS-B 3m HORN 9120D-HF HORIZONTAL RBW:1000.000KHz VBW:3000.000KHz SWT:Auto Detector : Peak Project : 652049-01 Mode : 2</p>
Avg.	 <p>Date: 2016-06-25</p> <p>Site : 03CH10-HY Condition : FCC CLASS-B (AVG) 3m HORN 9120D-HF HORIZONTAL RBW:1000.000KHz VBW:1000KHz SWT:Auto Detector : Peak Project : 652049-01 Mode : 2</p>	Left blank

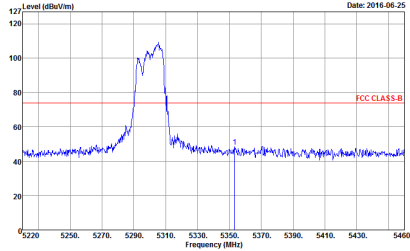
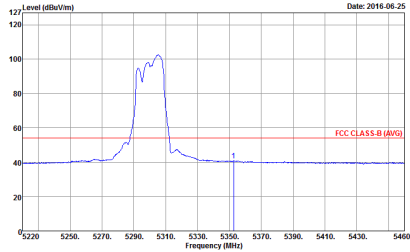

WIFI	Band 2 5250~5350MHz Band Edge @ 3m	
ANT	802.11a CH60 5300MHz - R	
1+2	Horizontal	Fundamental
Peak	 <p>Site : 03CH10-HY Condition : FCC CLASS-B 3m HORN 9120D-HF HORIZONTAL RBW:1000.000kHz VBW:3000.000kHz SWT:Auto Detector : Peak Project : 652049-01 Mode : 2</p>	Left blank
Avg.	 <p>Site : 03CH10-HY Condition : FCC CLASS-B (AVG) 3m HORN 9120D-HF HORIZONTAL RBW:1000.000kHz VBW:10000-hz SWT:Auto Detector : Peak Project : 652049-01 Mode : 2</p>	Left blank

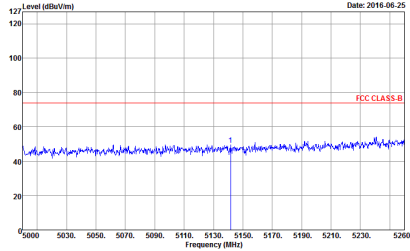
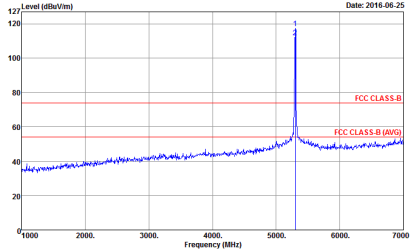
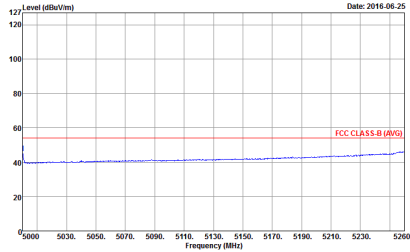

WIFI	Band 2 5250~5350MHz Band Edge @ 3m	
ANT	802.11a CH60 5300MHz - L	
1+2	Vertical	Fundamental
Peak	 <p>Site : 03CH10-HY Condition : FCC CLASS-B 3m HORN 9120D-HF VERTICAL RBW:1000.000KHz VBW:3000.000KHz SWT:Auto Detector : Peak Project : 652049-01 Mode : 2</p>	 <p>Site : 03CH10-HY Condition : FCC CLASS-B 3m HORN 9120D-HF VERTICAL RBW:1000.000KHz VBW:3000.000KHz SWT:Auto Detector : Peak Project : 652049-01 Mode : 2</p>
Avg.	 <p>Site : 03CH10-HY Condition : FCC CLASS-B (AVG) 3m HORN 9120D-HF VERTICAL RBW:1000.000KHz VBW:1000KHz SWT:Auto Detector : Peak Project : 652049-01 Mode : 2</p>	Left blank



WIFI	Band 2 5250~5350MHz Band Edge @ 3m	
ANT	802.11a CH60 5300MHz - R	
1+2	Vertical	Fundamental
Peak	<p> Site : 03CH10-HY Condition : FCC CLASS-B 3m HORN 9120D-HF VERTICAL RBW:1000.000kHz VBW:3000.000kHz SWT:Auto Detector : Peak Project : 652049-01 Mode : 2 </p>	Left blank
Avg.	<p> Site : 03CH10-HY Condition : FCC CLASS-B (AVG) 3m HORN 9120D-HF VERTICAL RBW:1000.000kHz VBW:10000-hz SWT:Auto Detector : Peak Project : 652049-01 Mode : 2 </p>	Left blank

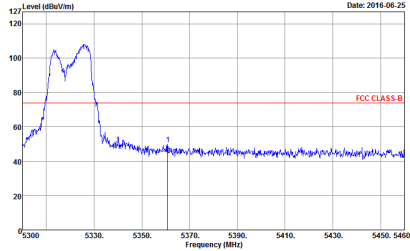
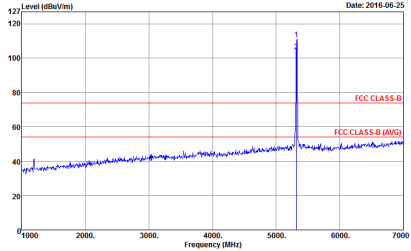
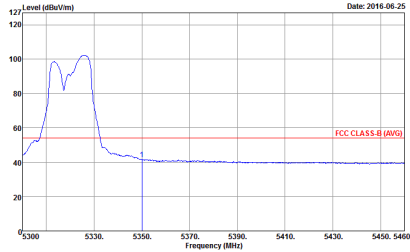

WIFI	Band 2 5250~5350MHz Band Edge @ 3m	
ANT	802.11a CH64 5320MHz	
1+2	Horizontal	Fundamental
Peak	 <p>Site : 03CH10-HY Condition : FCC CLASS-B 3m HORN 9120D-HF HORIZONTAL RBW:1000.000KHz VBW:3000.000KHz SWT:Auto Detector : Peak Project : 652049-01 Mode : 3</p>	 <p>Site : 03CH10-HY Condition : FCC CLASS-B 3m HORN 9120D-HF HORIZONTAL RBW:1000.000KHz VBW:3000.000KHz SWT:Auto Detector : Peak Project : 652049-01 Mode : 3</p>
Avg.	 <p>Site : 03CH10-HY Condition : FCC CLASS-B (AVG) 3m HORN 9120D-HF HORIZONTAL RBW:1000.000KHz VBW:1000KHz SWT:Auto Detector : Peak Project : 652049-01 Mode : 3</p>	Left blank

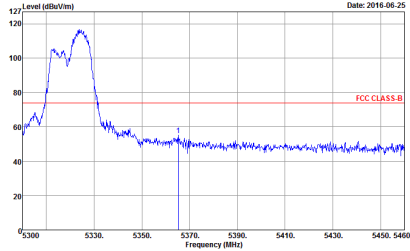
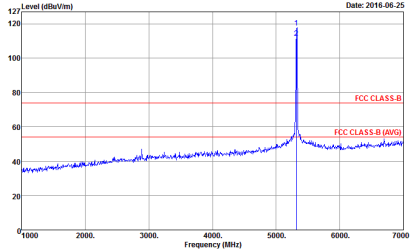
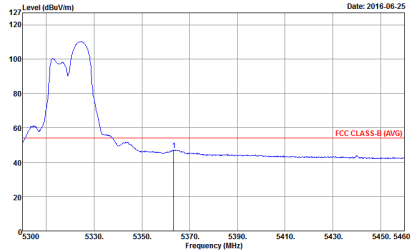

WIFI	Band 2 5250~5350MHz Band Edge @ 3m	
ANT	802.11a CH64 5320MHz	
1+2	Vertical	Fundamental
Peak	 <p>Date: 2016-06-25</p> <p>Site : 03CH10-HY Condition : FCC CLASS-B 3m HORN 9120D-HF VERTICAL RBW:1000.000KHz VBW:3000.000KHz SWT:Auto Detector : Peak Project : 652049-01 Mode : 3</p>	 <p>Date: 2016-06-25</p> <p>Site : 03CH10-HY Condition : FCC CLASS-B 3m HORN 9120D-HF VERTICAL RBW:1000.000KHz VBW:3000.000KHz SWT:Auto Detector : Peak Project : 652049-01 Mode : 3</p>
Avg.	 <p>Date: 2016-06-25</p> <p>Site : 03CH10-HY Condition : FCC CLASS-B (AVG) 3m HORN 9120D-HF VERTICAL RBW:1000.000KHz VBW:1000KHz SWT:Auto Detector : Peak Project : 652049-01 Mode : 3</p>	Left blank



Band 2 5250~5350MHz
WIFI 802.11ac VHT20 (Band Edge @ 3m)

WIFI	Band 2 5250~5350MHz Band Edge @ 3m	
ANT	802.11ac VHT20 CH52 5260MHz - L	
1+2	Horizontal	Fundamental
<p>Peak</p>	<p>Date: 2016-07-21</p> <p>Site : 03CH10-HY Condition : FCC CLASS-B 3m HORN 9120D-HF HORIZONTAL RBW:1000.000KHz VBW:3000.000KHz SWT:Auto Detector : Peak Project : 652049-01 Mode : 7</p>	<p>Date: 2016-07-21</p> <p>Site : 03CH10-HY Condition : FCC CLASS-B 3m HORN 9120D-HF HORIZONTAL RBW:1000.000KHz VBW:3000.000KHz SWT:Auto Detector : Peak Project : 652049-01 Mode : 7</p>
<p>Avg.</p>	<p>Date: 2016-07-21</p> <p>Site : 03CH10-HY Condition : FCC CLASS-B (AVG) 3m HORN 9120D-HF HORIZONTAL RBW:1000.000KHz VBW:1.000KHz SWT:Auto Detector : Peak Project : 652049-01 Mode : 7</p>	<p align="center">Left blank</p>

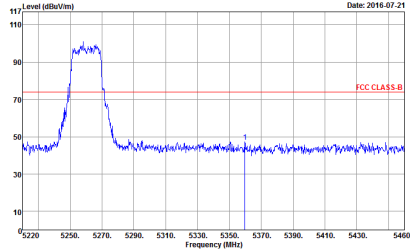
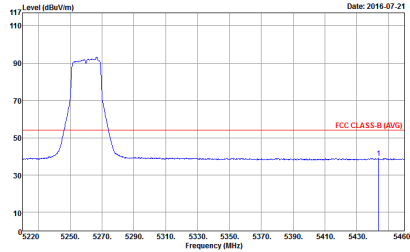

WIFI	Band 2 5250~5350MHz Band Edge @ 3m	
ANT	802.11ac VHT20 CH52 5260MHz - R	
1+2	Horizontal	Fundamental
Peak	 <p>Site : 03CH10-HY Condition : FCC CLASS-B 3m HORN 9120D-HF HORIZONTAL RBW:1000.000kHz VBW:3000.000kHz SWT:Auto Detector : Peak Project : 652049-01 Mode : 7</p>	Left blank
Avg.	 <p>Site : 03CH10-HY Condition : FCC CLASS-B (AVG) 3m HORN 9120D-HF HORIZONTAL RBW:1000.000kHz VBW:10000-hz SWT:Auto Detector : Peak Project : 652049-01 Mode : 7</p>	Left blank

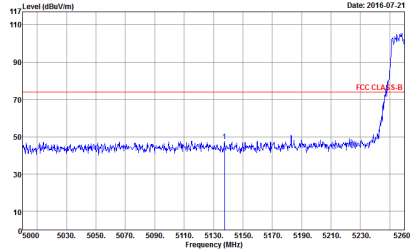
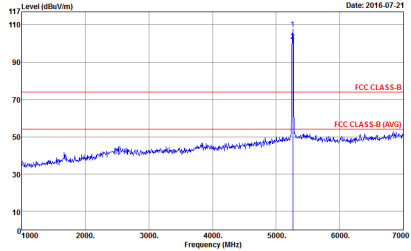
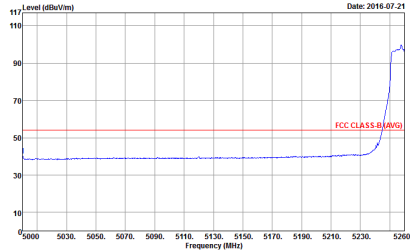

WIFI	Band 2 5250~5350MHz Band Edge @ 3m	
ANT	802.11ac VHT20 CH52 5260MHz - L	
1+2	Vertical	Fundamental
Peak	 <p>Site : 03CH10-HY Condition : FCC CLASS-B 3m HORN 9120D-HF VERTICAL RBW:1000.000KHz VBW:3000.000KHz SWT:Auto Detector : Peak Project : 652049-01 Mode : 7</p>	 <p>Site : 03CH10-HY Condition : FCC CLASS-B 3m HORN 9120D-HF VERTICAL RBW:1000.000KHz VBW:3000.000KHz SWT:Auto Detector : Peak Project : 652049-01 Mode : 7</p>
Avg.	 <p>Site : 03CH10-HY Condition : FCC CLASS-B (AVG) 3m HORN 9120D-HF VERTICAL RBW:1000.000KHz VBW:1000KHz SWT:Auto Detector : Peak Project : 652049-01 Mode : 7</p>	Left blank

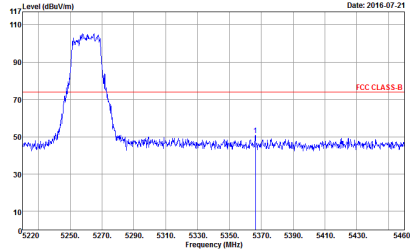
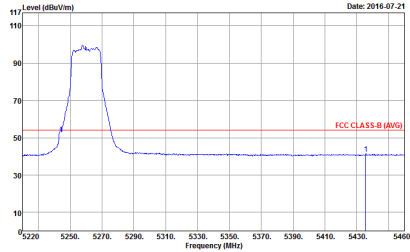

WIFI	Band 2 5250~5350MHz Band Edge @ 3m	
ANT	802.11ac VHT20 CH52 5260MHz - R	
1+2	Vertical	Fundamental
Peak	 <p>Date: 2016-07-21</p> <p>Site : 03CH10-HY Condition : FCC CLASS-B 3m HORN 9120D-HF VERTICAL RBW:1000.000kHz VBW:3000.000kHz SWT:Auto Detector : Peak Project : 652049-01 Mode : 7</p>	Left blank
Avg.	 <p>Date: 2016-07-21</p> <p>Site : 03CH10-HY Condition : FCC CLASS-B (AVG) 3m HORN 9120D-HF VERTICAL RBW:1000.000kHz VBW:10000-hz SWT:Auto Detector : Peak Project : 652049-01 Mode : 7</p>	Left blank

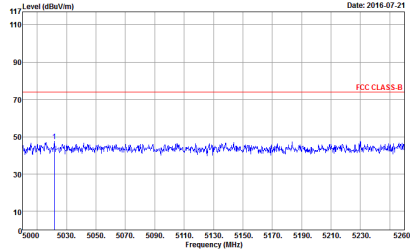
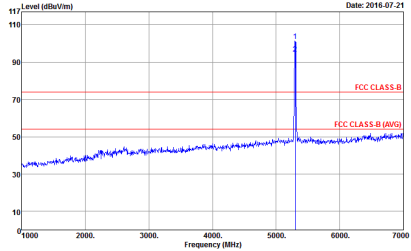
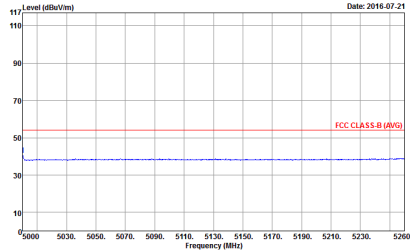

WIFI	Band 2 5250~5350MHz Band Edge @ 3m	
ANT	802.11ac VHT20 CH60 5300MHz - L	
1+2	Horizontal	Fundamental
Peak	 <p>Date: 2016-07-21</p> <p>Site : 03CH10-HY Condition : FCC CLASS-B 3m HORN 9120D-HF HORIZONTAL RBW:1000.000KHz VBW:3000.000KHz SWT:Auto Detector : Peak Project : 652049-01 Mode : 8</p>	 <p>Date: 2016-07-21</p> <p>Site : 03CH10-HY Condition : FCC CLASS-B 3m HORN 9120D-HF HORIZONTAL RBW:1000.000KHz VBW:3000.000KHz SWT:Auto Detector : Peak Project : 652049-01 Mode : 8</p>
Avg.	 <p>Date: 2016-07-21</p> <p>Site : 03CH10-HY Condition : FCC CLASS-B (AVG) 3m HORN 9120D-HF HORIZONTAL RBW:1000.000KHz VBW:1000KHz SWT:Auto Detector : Peak Project : 652049-01 Mode : 8</p>	Left blank

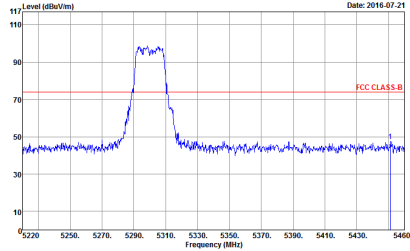
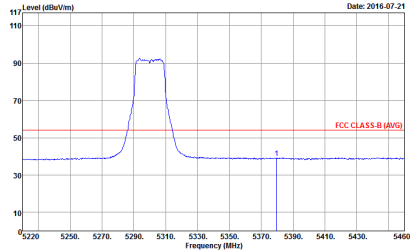

WIFI	Band 2 5250~5350MHz Band Edge @ 3m	
ANT	802.11ac VHT20 CH60 5300MHz - R	
1+2	Horizontal	Fundamental
Peak	 <p>Site : 03CH10-HY Condition : FCC CLASS-B 3m HORN 9120D-HF HORIZONTAL RBW:1000.000kHz VBW:3000.000kHz SWT:Auto Detector : Peak Project : 652049-01 Mode : B</p>	Left blank
Avg.	 <p>Site : 03CH10-HY Condition : FCC CLASS-B (AVG) 3m HORN 9120D-HF HORIZONTAL RBW:1000.000kHz VBW:10000-hz SWT:Auto Detector : Peak Project : 652049-01 Mode : B</p>	Left blank

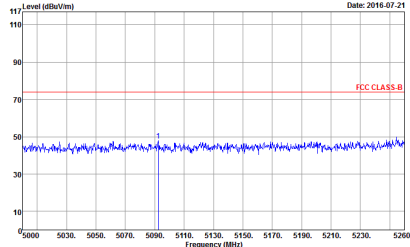
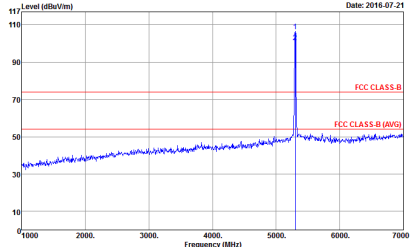
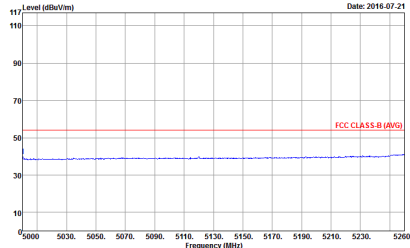

WIFI	Band 2 5250~5350MHz Band Edge @ 3m	
ANT	802.11ac VHT20 CH60 5300MHz - L	
1+2	Vertical	Fundamental
Peak	 <p>Date: 2016-07-21</p> <p>Site : 03CH10-HY Condition : FCC CLASS-B 3m HORN 9120D-HF VERTICAL RBW:1000.000KHz VBW:3000.000KHz SWT:Auto Detector : Peak Project : 652049-01 Mode : 8</p>	 <p>Date: 2016-07-21</p> <p>Site : 03CH10-HY Condition : FCC CLASS-B 3m HORN 9120D-HF VERTICAL RBW:1000.000KHz VBW:3000.000KHz SWT:Auto Detector : Peak Project : 652049-01 Mode : 8</p>
Avg.	 <p>Date: 2016-07-21</p> <p>Site : 03CH10-HY Condition : FCC CLASS-B (AVG) 3m HORN 9120D-HF VERTICAL RBW:1000.000KHz VBW:1000KHz SWT:Auto Detector : Peak Project : 652049-01 Mode : 8</p>	Left blank

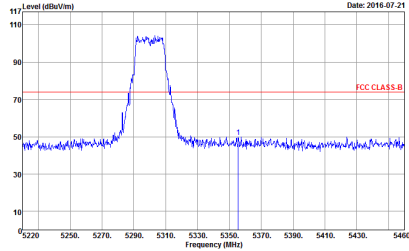
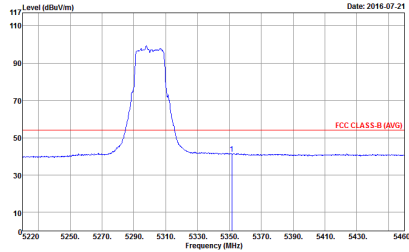

WIFI	Band 2 5250~5350MHz Band Edge @ 3m	
ANT	802.11ac VHT20 CH60 5300MHz - R	
1+2	Vertical	Fundamental
Peak	 <p>Date: 2016-07-21</p> <p>Site : 03CH10-HY Condition : FCC CLASS-B 3m HORN 9120D-HF VERTICAL RBW:1000.000kHz VBW:3000.000kHz SWT:Auto Detector : Peak Project : 652049-01 Mode : B</p>	Left blank
Avg.	 <p>Date: 2016-07-21</p> <p>Site : 03CH10-HY Condition : FCC CLASS-B (AVG) 3m HORN 9120D-HF VERTICAL RBW:1000.000kHz VBW:10000-hz SWT:Auto Detector : Peak Project : 652049-01 Mode : B</p>	Left blank

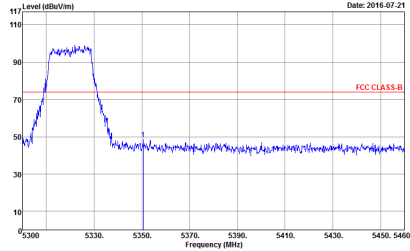
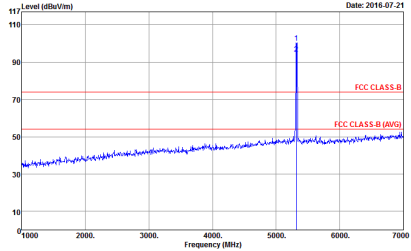
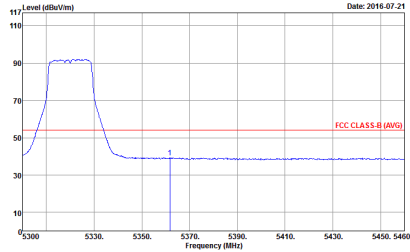

WIFI	Band 2 5250~5350MHz Band Edge @ 3m	
ANT	802.11ac VHT20 CH64 5320MHz	
1+2	Horizontal	Fundamental
<p>Peak</p>	 <p>Site : 03CH10-HY Condition : FCC CLASS-B 3m HORN 9120D-HF HORIZONTAL RBW:1000.000kHz VBW:3000.000kHz SWT:Auto Detector : Peak Project : 652049-01 Mode : 9</p>	 <p>Site : 03CH10-HY Condition : FCC CLASS-B 3m HORN 9120D-HF HORIZONTAL RBW:1000.000kHz VBW:3000.000kHz SWT:Auto Detector : Peak Project : 652049-01 Mode : 9</p>
<p>Avg.</p>	 <p>Site : 03CH10-HY Condition : FCC CLASS-B (AVG) 3m HORN 9120D-HF HORIZONTAL RBW:1000.000kHz VBW:10000-hz SWT:Auto Detector : Peak Project : 652049-01 Mode : 9</p>	<p>Left blank</p>

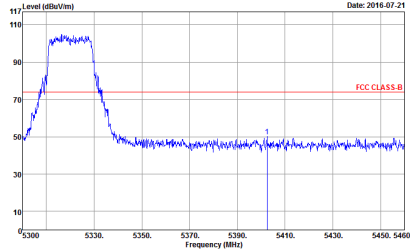
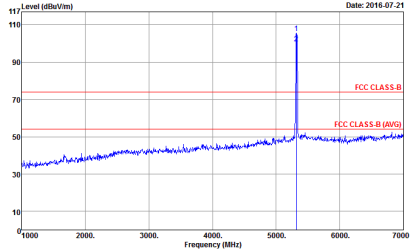
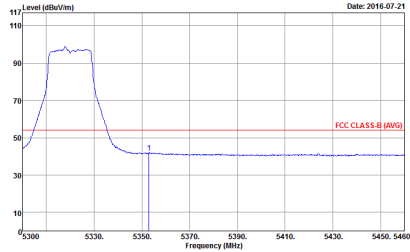

WIFI	Band 2 5250~5350MHz Band Edge @ 3m	
ANT	802.11ac VHT20 CH64 5320MHz	
1+2	Vertical	Fundamental
Peak	 <p>Site : 03CH10-HY Condition : FCC CLASS-B 3m HORN 9120D-HF VERTICAL RBW:1000.000KHz VBW:3000.000KHz SWT:Auto Detector : Peak Project : 652049-01 Mode : 9</p>	 <p>Site : 03CH10-HY Condition : FCC CLASS-B 3m HORN 9120D-HF VERTICAL RBW:1000.000KHz VBW:3000.000KHz SWT:Auto Detector : Peak Project : 652049-01 Mode : 9</p>
Avg.	 <p>Site : 03CH10-HY Condition : FCC CLASS-B (AVG) 3m HORN 9120D-HF VERTICAL RBW:1000.000KHz VBW:1000KHz SWT:Auto Detector : Peak Project : 652049-01 Mode : 9</p>	Left blank

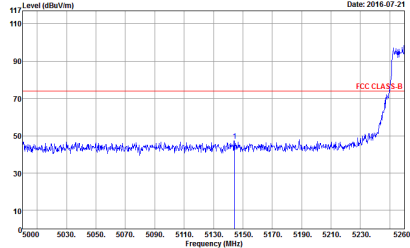
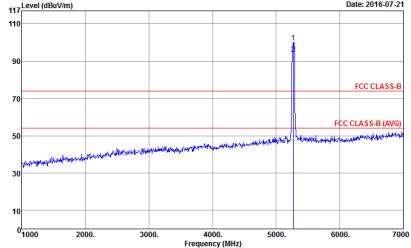
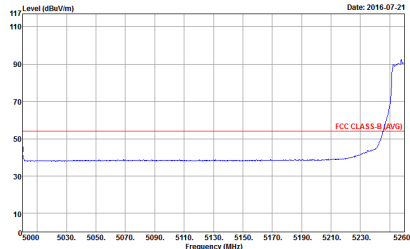

Band 2 5250~5350MHz
WIFI 802.11ac VHT40 (Band Edge @ 3m)

WIFI	Band 2 5250~5350MHz Band Edge @ 3m	
ANT	802.11ac VHT40 CH54 5270 - L	
1+2	Horizontal	Fundamental
<p>Peak</p>	 <p>Date: 2016-07-21</p> <p>Site : 03CH10-HY Condition : FCC CLASS-B 3m HORN 9120D-HF HORIZONTAL RBW:1000.000KHz VBW:3000.000KHz SWT:Auto Detector : Peak Project : 652049-01 Mode : 13</p>	 <p>Date: 2016-07-21</p> <p>Site : 03CH10-HY Condition : FCC CLASS-B 3m HORN 9120D-HF HORIZONTAL RBW:1000.000KHz VBW:3000.000KHz SWT:Auto Detector : Peak Project : 652049-01 Mode : 13</p>
<p>Avg.</p>	 <p>Date: 2016-07-21</p> <p>Site : 03CH10-HY Condition : FCC CLASS-B (AVG) 3m HORN 9120D-HF HORIZONTAL RBW:1000.000KHz VBW:1.000KHz SWT:Auto Detector : Peak Project : 652049-01 Mode : 13</p>	<p align="center">Left blank</p>

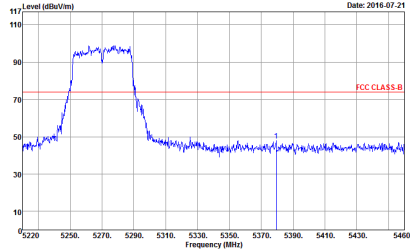
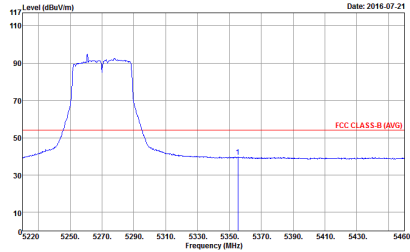

WIFI	Band 2 5250~5350MHz Band Edge @ 3m	
ANT	802.11ac VHT40 CH54 5270 - R	
1+2	Horizontal	Fundamental
<p>Peak</p>	 <p>Date: 2016-07-21</p> <p>Site : 03CH10-HY Condition : FCC CLASS-B 3m HORN 9120D-HF HORIZONTAL RBW:1000.000kHz VBW:3000.000kHz SWT:Auto Detector : Peak Project : 652049-01 Mode : 13</p>	<p>Left blank</p>
<p>Avg.</p>	 <p>Date: 2016-07-21</p> <p>Site : 03CH10-HY Condition : FCC CLASS-B (AVG) 3m HORN 9120D-HF HORIZONTAL RBW:1000.000kHz VBW:10000-hz SWT:Auto Detector : Peak Project : 652049-01 Mode : 13</p>	<p>Left blank</p>

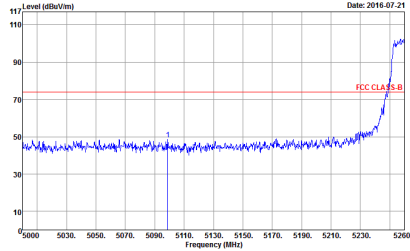
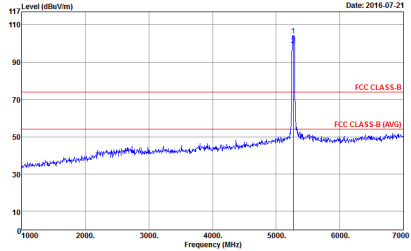
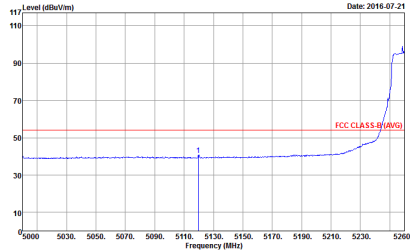

WIFI	Band 2 5250~5350MHz Band Edge @ 3m	
ANT	802.11ac VHT40 CH54 5270 - L	
1+2	Vertical	Fundamental
Peak	 <p>Date: 2016-07-21</p> <p>Site : 03CH10-HY Condition : FCC CLASS-B 3m HORN 9120D-HF VERTICAL RBW:1000.000KHz VBW:3000.000KHz SWT:Auto Detector : Peak Project : 652049-01 Mode : 13</p>	 <p>Date: 2016-07-21</p> <p>Site : 03CH10-HY Condition : FCC CLASS-B 3m HORN 9120D-HF VERTICAL RBW:1000.000KHz VBW:3000.000KHz SWT:Auto Detector : Peak Project : 652049-01 Mode : 13</p>
Avg.	 <p>Date: 2016-07-21</p> <p>Site : 03CH10-HY Condition : FCC CLASS-B (AVG) 3m HORN 9120D-HF VERTICAL RBW:1000.000KHz VBW:1000KHz SWT:Auto Detector : Peak Project : 652049-01 Mode : 13</p>	Left blank

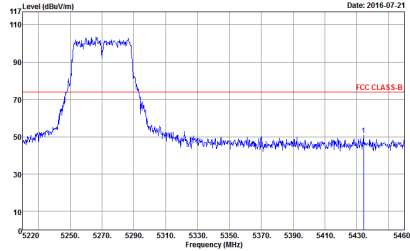
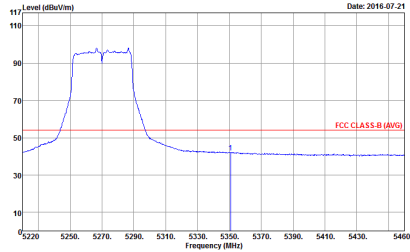

WIFI	Band 2 5250~5350MHz Band Edge @ 3m	
ANT	802.11ac VHT40 CH54 5270 - R	
1+2	Vertical	Fundamental
<p>Peak</p>	 <p>Site : 03CH10-HY Condition : FCC CLASS-B 3m HORN 9120D-HF VERTICAL RBW:1000.000KHz VBW:3000.000KHz SWT:Auto Detector : Peak Project : 652049-01 Mode : 13</p>	<p>Left blank</p>
<p>Avg.</p>	 <p>Site : 03CH10-HY Condition : FCC CLASS-B (AVG) 3m HORN 9120D-HF VERTICAL RBW:1000.000KHz VBW:1000KHz SWT:Auto Detector : Peak Project : 652049-01 Mode : 13</p>	<p>Left blank</p>

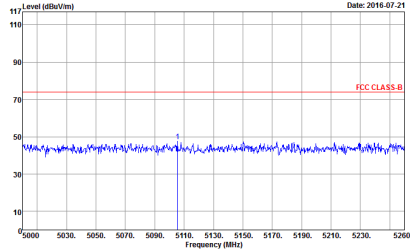
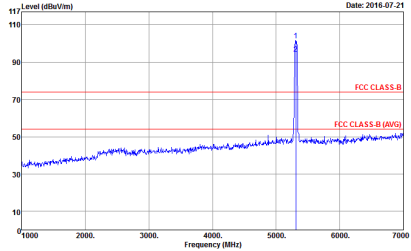
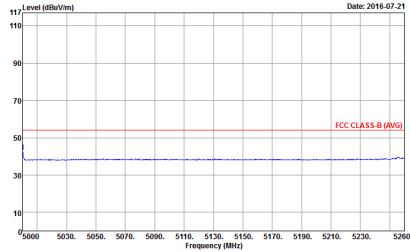

WIFI	Band 2 5250~5350MHz Band Edge @ 3m	
ANT	802.11ac VHT40 CH62 5310 - L	
1+2	Horizontal	Fundamental
<p>Peak</p>	 <p>Date: 2016-07-21</p> <p>Site : 03CH10-HY Condition : FCC CLASS-B 3m HORN 9120D-HF HORIZONTAL RBW:1000.000KHz VBW:3000.000KHz SWT:Auto Detector : Peak Project : 652049-01 Mode : 14</p>	 <p>Date: 2016-07-21</p> <p>Site : 03CH10-HY Condition : FCC CLASS-B 3m HORN 9120D-HF HORIZONTAL RBW:1000.000KHz VBW:3000.000KHz SWT:Auto Detector : Peak Project : 652049-01 Mode : 14</p>
<p>Avg.</p>	 <p>Date: 2016-07-21</p> <p>Site : 03CH10-HY Condition : FCC CLASS-B (AVG) 3m HORN 9120D-HF HORIZONTAL RBW:1000.000KHz VBW:1000KHz SWT:Auto Detector : Peak Project : 652049-01 Mode : 14</p>	<p>Left blank</p>

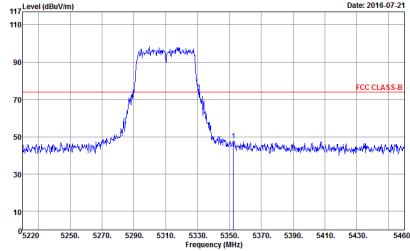
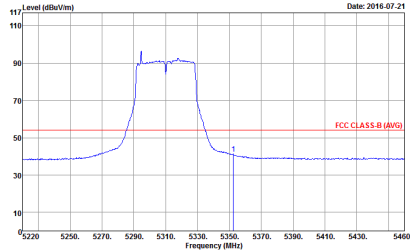

WIFI	Band 2 5250~5350MHz Band Edge @ 3m	
ANT	802.11ac VHT40 CH62 5310 - R	
1+2	Horizontal	Fundamental
Peak	 <p> Site : 03CH10-HY Condition : FCC CLASS-B 3m HORN 9120D-HF HORIZONTAL RBW:1000.000kHz VBW:3000.000kHz SWT:Auto Detector : Peak Project : 652049-01 Mode : 14 </p>	Left blank
Avg.	 <p> Site : 03CH10-HY Condition : FCC CLASS-B (AVG) 3m HORN 9120D-HF HORIZONTAL RBW:1000.000kHz VBW:10000-hz SWT:Auto Detector : Peak Project : 652049-01 Mode : 14 </p>	Left blank

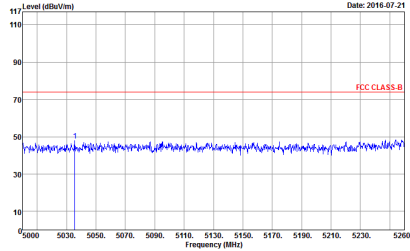
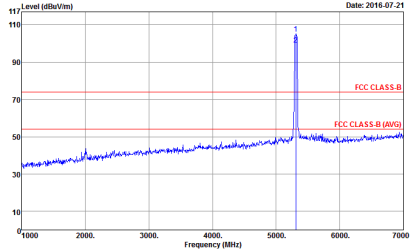
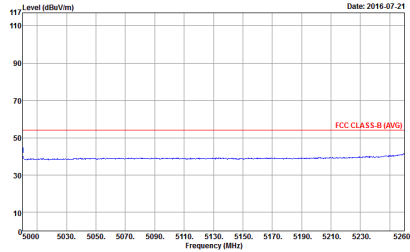

WIFI	Band 2 5250~5350MHz Band Edge @ 3m	
ANT	802.11ac VHT40 CH62 5310 - L	
1+2	Vertical	Fundamental
Peak	 <p>Date: 2016-07-21</p> <p>Site : 03CH10-HY Condition : FCC CLASS-B 3m HORN 9120D-HF VERTICAL RBW:1000.000KHz VBW:3000.000KHz SWT:Auto Detector : Peak Project : 652049-01 Mode : 14</p>	 <p>Date: 2016-07-21</p> <p>Site : 03CH10-HY Condition : FCC CLASS-B 3m HORN 9120D-HF VERTICAL RBW:1000.000KHz VBW:3000.000KHz SWT:Auto Detector : Peak Project : 652049-01 Mode : 14</p>
Avg.	 <p>Date: 2016-07-21</p> <p>Site : 03CH10-HY Condition : FCC CLASS-B (AVG) 3m HORN 9120D-HF VERTICAL RBW:1000.000KHz VBW:1000KHz SWT:Auto Detector : Peak Project : 652049-01 Mode : 14</p>	Left blank

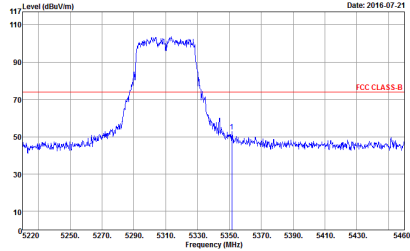
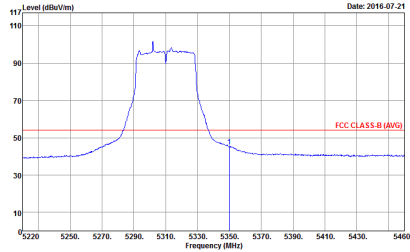

WIFI	Band 2 5250~5350MHz Band Edge @ 3m	
ANT	802.11ac VHT40 CH62 5310 - R	
1+2	Vertical	Fundamental
Peak	 <p> Site : 03CH10-HY Condition : FCC CLASS-B 3m HORN 9120D-HF VERTICAL RBW:1000.000kHz VBW:3000.000kHz SWT:Auto Detector : Peak Project : 652049-01 Mode : 14 </p>	Left blank
Avg.	 <p> Site : 03CH10-HY Condition : FCC CLASS-B (AVG) 3m HORN 9120D-HF VERTICAL RBW:1000.000kHz VBW:10000-hz SWT:Auto Detector : Peak Project : 652049-01 Mode : 14 </p>	Left blank

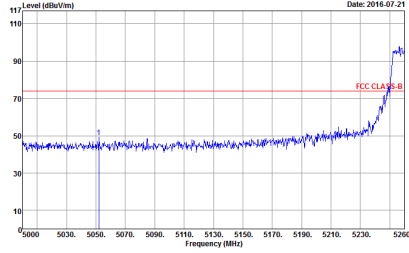
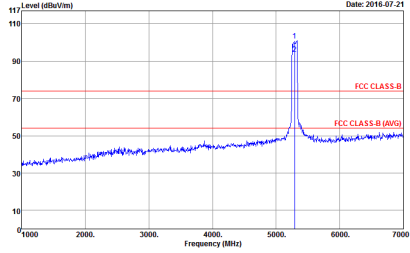
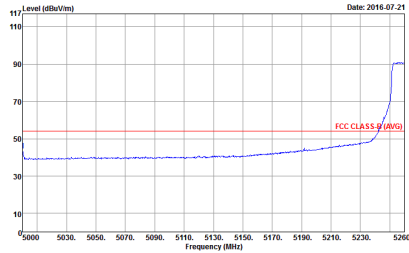

Band 2 5250~5350MHz
WIFI 802.11ac VHT80 (Band Edge @ 3m)

WIFI	Band 2 5250~5350MHz Band Edge @ 3m	
ANT	802.11ac VHT80 CH58 5290MHz - L	
1+2	Horizontal	Fundamental
<p>Peak</p>	 <p>Date: 2016-07-21</p> <p>Site : 03CH10-HY Condition : FCC CLASS-B 3m HORN 9120D-HF HORIZONTAL RBW:1000.000KHz VBW:3000.000KHz SWT:Auto Detector : Peak Project : 652049-01 Mode : 18</p>	 <p>Date: 2016-07-21</p> <p>Site : 03CH10-HY Condition : FCC CLASS-B 3m HORN 9120D-HF HORIZONTAL RBW:1000.000KHz VBW:3000.000KHz SWT:Auto Detector : Peak Project : 652049-01 Mode : 18</p>
<p>Avg.</p>	 <p>Date: 2016-07-21</p> <p>Site : 03CH10-HY Condition : FCC CLASS-B (AVG) 3m HORN 9120D-HF HORIZONTAL RBW:1000.000KHz VBW:3.000KHz SWT:Auto Detector : Peak Project : 652049-01 Mode : 18</p>	<p align="center">Left blank</p>

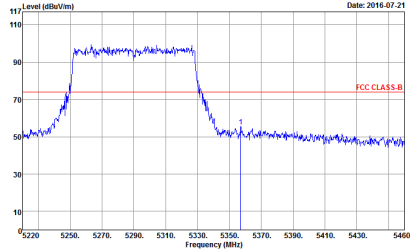
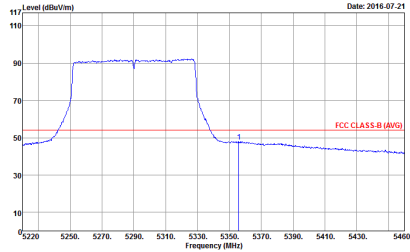

WIFI	Band 2 5250~5350MHz Band Edge @ 3m	
ANT	802.11ac VHT80 CH58 5290MHz - R	
1+2	Horizontal	Fundamental
Peak	 <p>Site : 03CH10-HY Condition : FCC CLASS-B 3m HORN 9120D-HF HORIZONTAL RBW:1000.000KHz VBW:3000.000KHz SWT:Auto Detector : Peak Project : 652049-01 Mode : 1B</p>	Left blank
Avg.	 <p>Site : 03CH10-HY Condition : FCC CLASS-B (AVG) 3m HORN 9120D-HF HORIZONTAL RBW:1000.000KHz VBW:3.000KHz SWT:Auto Detector : Peak Project : 652049-01 Mode : 1B</p>	Left blank



WIFI	Band 2 5250~5350MHz Band Edge @ 3m	
ANT	802.11ac VHT80 CH58 5290MHz - L	
1+2	Vertical	Fundamental
<p>Peak</p>	<p>Site : 03CH10-HY Condition : FCC CLASS-B 3m HORN 9120D-HF VERTICAL RBW:1000.000KHz VBW:3000.000KHz SWT:Auto Detector : Peak Project : 652049-01 Mode : 18</p>	<p>Site : 03CH10-HY Condition : FCC CLASS-B 3m HORN 9120D-HF VERTICAL RBW:1000.000KHz VBW:3000.000KHz SWT:Auto Detector : Peak Project : 652049-01 Mode : 18</p>
<p>Avg.</p>	<p>Site : 03CH10-HY Condition : FCC CLASS-B (AVG) 3m HORN 9120D-HF VERTICAL RBW:1000.000KHz VBW:3.000KHz SWT:Auto Detector : Peak Project : 652049-01 Mode : 18</p>	<p>Left blank</p>

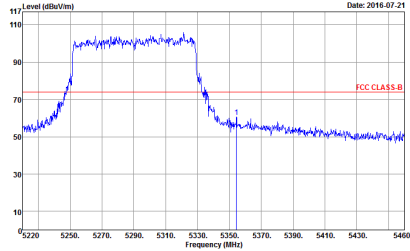
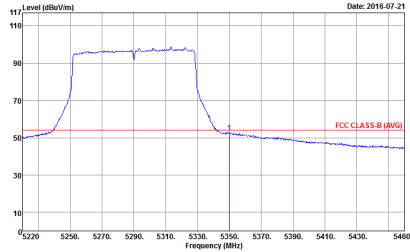

WIFI	Band 2 5250~5350MHz Band Edge @ 3m	
ANT	802.11ac VHT80 CH58 5290MHz - R	
1+2	Vertical	Fundamental
Peak	 <p>Site : 03CH10-HY Condition : FCC CLASS-B 3m HORN 9120D-HF VERTICAL RBW:1000.000KHz VBW:3000.000KHz SWT:Auto Detector : Peak Project : 652049-01 Mode : 1B</p>	Left blank
Avg.	 <p>Site : 03CH10-HY Condition : FCC CLASS-B (AVG) 3m HORN 9120D-HF VERTICAL RBW:1000.000KHz VBW:3.000KHz SWT:Auto Detector : Peak Project : 652049-01 Mode : 1B</p>	Left blank

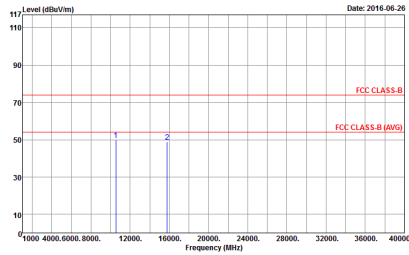
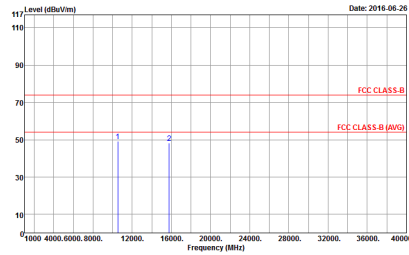

Band 2 - 5250~5350MHz
WIFI 802.11a (Harmonic @ 3m)

WIFI	Band 2 5250~5350MHz Harmonic @ 3m	
ANT	802.11a CH52 5260MHz	
1+2	Horizontal	Vertical
Peak	 <p>Site : 03CH10-HY Condition : FCC CLASS-B 3m HORN 9120D-HF HORIZONTAL Detector : Peak Project : 652049-01 Mode : 1</p>	 <p>Site : 03CH10-HY Condition : FCC CLASS-B 3m HORN 9120D-HF VERTICAL Detector : Peak Project : 652049-01 Mode : 1</p>
Avg.		

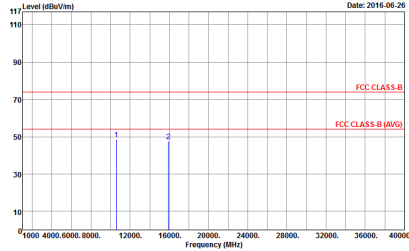
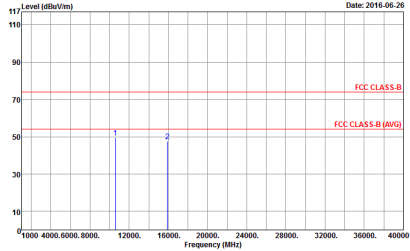

WIFI	Band 2 5250~5350MHz Harmonic @ 3m	
ANT	802.11a CH60 5300MHz	
1+2	Horizontal	Vertical
<p>Peak</p> <p>Avg.</p>	 <p>Site : 08CH10-HY Condition : FCC CLASS-B 3m HORN 9120D-HF HORIZONTAL Detector : Peak Project : 652049-01 Mode : 2</p>	 <p>Site : 08CH10-HY Condition : FCC CLASS-B 3m HORN 9120D-HF VERTICAL Detector : Peak Project : 652049-01 Mode : 2</p>

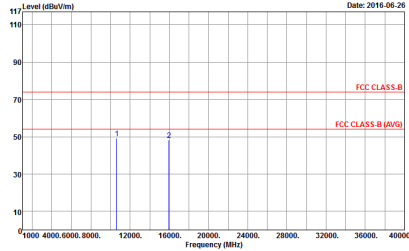
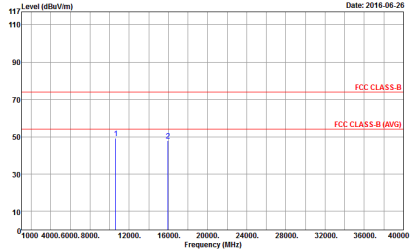

WIFI	Band 2 5250~5350MHz Harmonic @ 3m	
ANT	802.11a CH64 5320MHz	
1+2	Horizontal	Vertical
<p>Peak</p> <p>Avg.</p>	 <p>Site : 00CH10-HY Condition : FCC CLASS-B 3m HORN 9120D-HF HORIZONTAL Detector : Peak Project : 652049-01 Mode : 3</p>	 <p>Site : 00CH10-HY Condition : FCC CLASS-B 3m HORN 9120D-HF VERTICAL Detector : Peak Project : 652049-01 Mode : 3</p>

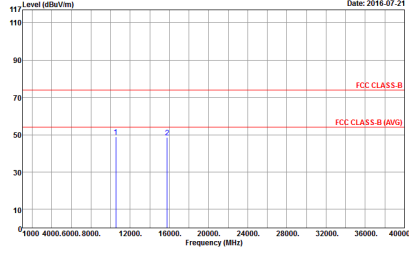
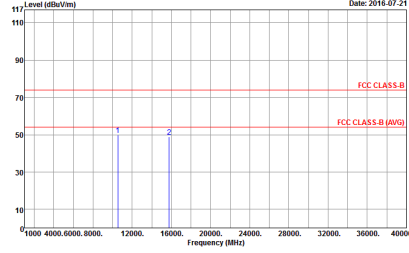

Band 2 5250~5350MHz
WIFI 802.11ac VHT20 (Harmonic @ 3m)

WIFI	Band 2 5250~5350MHz Harmonic @ 3m	
ANT	802.11ac VHT20 CH52 5260MHz	
1+2	Horizontal	Vertical
Peak Avg.	 <p>Date: 2016-07-21</p> <p>Site : 03CH10-HY Condition : FCC CLASS-B 3m HORN 9120D-HF HORIZONTAL Detector : Peak Project : 652049-01 Mode : 7</p>	 <p>Date: 2016-07-21</p> <p>Site : 03CH10-HY Condition : FCC CLASS-B 3m HORN 9120D-HF VERTICAL Detector : Peak Project : 652049-01 Mode : 7</p>

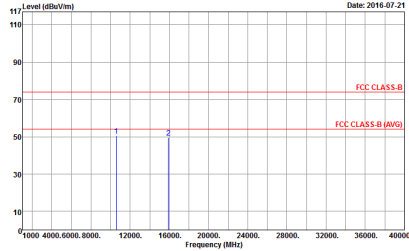
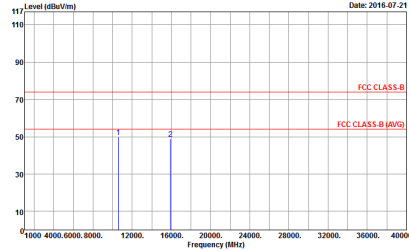

WIFI	Band 2 5250~5350MHz Harmonic @ 3m	
ANT	802.11ac VHT20 CH60 5300MHz	
1+2	Horizontal	Vertical
<p>Peak</p> <p>Avg.</p>	 <p>Site : 03CH10-HY Condition : FCC CLASS-B 3m HORN 9120D-HF HORIZONTAL Detector : Peak Project : 652049-01 Mode : B</p>	 <p>Site : 03CH10-HY Condition : FCC CLASS-B 3m HORN 9120D-HF VERTICAL Detector : Peak Project : 652049-01 Mode : B</p>

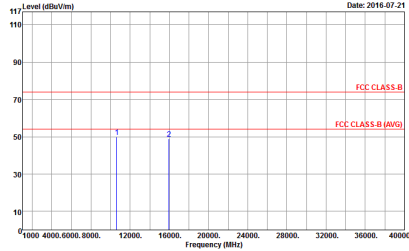
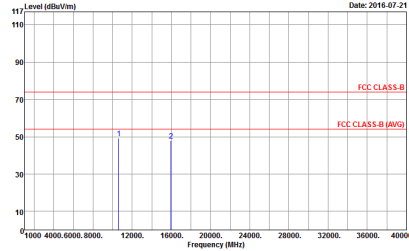

WIFI	Band 2 5250~5350MHz Harmonic @ 3m	
ANT	802.11ac VHT20 CH64 5320MHz	
1+2	Horizontal	Vertical
<p>Peak</p> <p>Avg.</p>	 <p>Site : 08CH10-HY Condition : FCC CLASS-B 3m HORN 9120D-HF HORIZONTAL Detector : Peak Project : 652049-01 Mode : 9</p>	 <p>Site : 08CH10-HY Condition : FCC CLASS-B 3m HORN 9120D-HF VERTICAL Detector : Peak Project : 652049-01 Mode : 9</p>

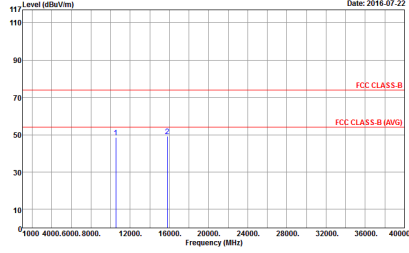
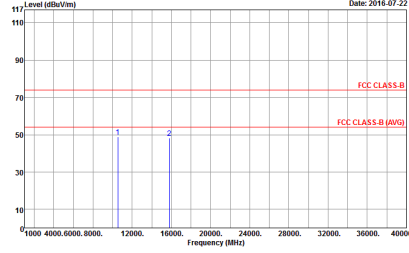

**Band 2 5250~5350MHz
WIFI 802.11ac VHT40 (Harmonic @ 3m)**

WIFI	Band 2 5250~5350MHz Harmonic @ 3m	
ANT	802.11ac VHT40 CH54 5270	
1+2	Horizontal	Vertical
<p>Peak</p> <p>Avg.</p>	 <p>Date: 2016-07-22</p> <p>Site : 03CH10-HY Condition : FCC CLASS-B 3m HORN 9120D-HF HORIZONTAL Detector : Peak Project : 652049-01 Mode : 13</p>	 <p>Date: 2016-07-22</p> <p>Site : 03CH10-HY Condition : FCC CLASS-B 3m HORN 9120D-HF VERTICAL Detector : Peak Project : 652049-01 Mode : 13</p>

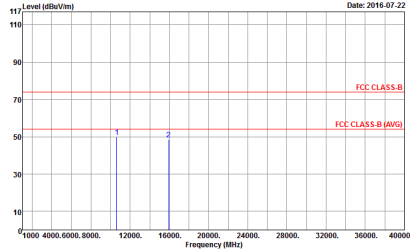
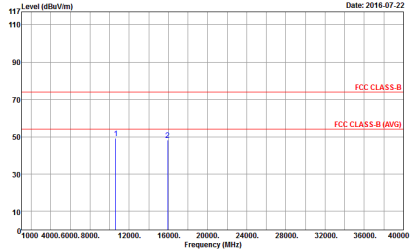

WIFI	Band 2 5250~5350MHz Harmonic @ 3m	
ANT	802.11ac VHT40 CH62 5310	
1+2	Horizontal	Vertical
<p>Peak</p> <p>Avg.</p>	 <p>Site : 08CH10-HY Condition : FCC CLASS-B 3m HORN 9120D-HF HORIZONTAL Detector : Peak Project : 652049-01 Mode : 14</p>	 <p>Site : 08CH10-HY Condition : FCC CLASS-B 3m HORN 9120D-HF VERTICAL Detector : Peak Project : 652049-01 Mode : 14</p>



**Band 2 5250~5350MHz
WIFI 802.11ac VHT80 (Harmonic @ 3m)**

WIFI	Band 2 5250~5350MHz Harmonic @ 3m	
ANT	802.11ac VHT80 CH58 5290MHz	
1+2	Horizontal	Vertical
Peak Avg.	<p>Date: 2016-07-22</p> <p>Site : 03CH10-HY Condition : FCC CLASS-B 3m HORN 9120D-HF HORIZONTAL Detector : Peak Project : 652049-01 Mode : 18</p>	<p>Date: 2016-07-22</p> <p>Site : 03CH10-HY Condition : FCC CLASS-B 3m HORN 9120D-HF VERTICAL Detector : Peak Project : 652049-01 Mode : 18</p>

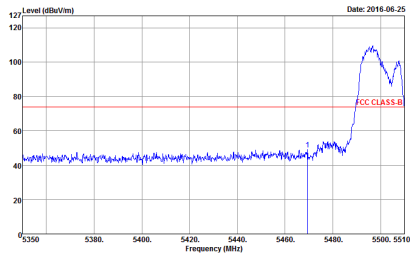
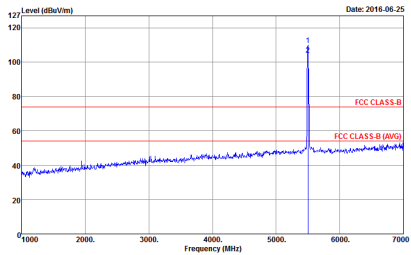
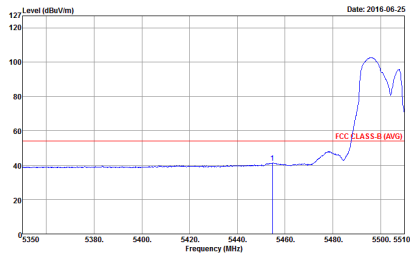

Band 3 - 5470~5725MHz
WIFI 802.11a (Band Edge @ 3m)

WIFI	Band 3 5470~5725MHz Band Edge @ 3m	
ANT	802.11a CH100 5500MHZ	
1+2	Horizontal	Fundamental
<p>Peak</p>	 <p>Site : 03CH10-HY Condition : FCC CLASS-B 3m HORN 9120D-HF HORIZONTAL RBW:1000.000kHz VBW:3000.000kHz SWT:Auto Detector : Peak Project : 652049 Mode : 4</p>	 <p>Site : 03CH10-HY Condition : FCC CLASS-B 3m HORN 9120D-HF HORIZONTAL RBW:1000.000kHz VBW:3000.000kHz SWT:Auto Detector : Peak Project : 652049 Mode : 4</p>
<p>Avg.</p>	 <p>Site : 03CH10-HY Condition : FCC CLASS-B (AVG) 3m HORN 9120D-HF HORIZONTAL RBW:1000.000kHz VBW:1000kHz SWT:Auto Detector : Peak Project : 652049 Mode : 4</p>	<p align="center">Left blank</p>



WIFI	Band 3 5470~5725MHz Band Edge @ 3m	
ANT	802.11a CH100 5500MHz	
1+2	Vertical	Fundamental
<p>Peak</p>	<p>Site : 03CH10-HY Condition : FCC CLASS-B 3m HORN 9120D-HF VERTICAL RBW:1000.000KHz VBW:3000.000KHz SWT:Auto Detector : Peak Project : 652049 Mode : 4</p>	<p>Site : 03CH10-HY Condition : FCC CLASS-B 3m HORN 9120D-HF VERTICAL RBW:1000.000KHz VBW:3000.000KHz SWT:Auto Detector : Peak Project : 652049 Mode : 4</p>
<p>Avg.</p>	<p>Site : 03CH10-HY Condition : FCC CLASS-B (AVG) 3m HORN 9120D-HF VERTICAL RBW:1000.000KHz VBW:10000KHz SWT:Auto Detector : Peak Project : 652049 Mode : 4</p>	<p>Left blank</p>

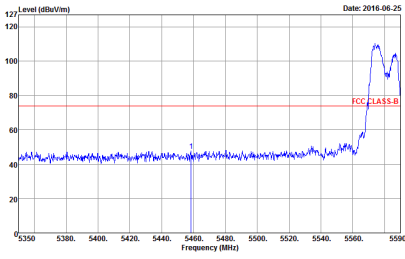
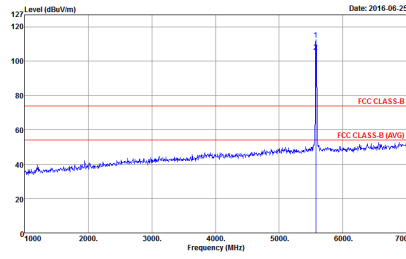
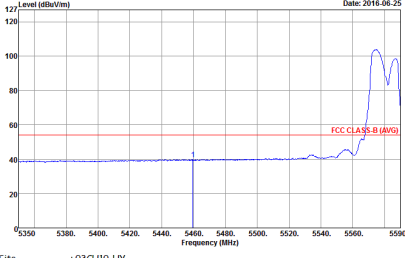

WIFI	Band 3 5470~5725MHz Band Edge @ 3m	
ANT	802.11a CH116 5580MHz - L	
1+2	Horizontal	Fundamental
Peak	 <p>Date: 2016-06-25</p> <p>Site : 03CH10-HY Condition : FCC CLASS-B 3m HORN 9120D-HF HORIZONTAL RBW:1000.000KHz VBW:3000.000KHz SWT:Auto Detector : Peak Project : 652049 Mode : 5</p>	 <p>Date: 2016-06-25</p> <p>Site : 03CH10-HY Condition : FCC CLASS-B 3m HORN 9120D-HF HORIZONTAL RBW:1000.000KHz VBW:3000.000KHz SWT:Auto Detector : Peak Project : 652049 Mode : 5</p>
Avg.	 <p>Date: 2016-06-25</p> <p>Site : 03CH10-HY Condition : FCC CLASS-B (AVG) 3m HORN 9120D-HF HORIZONTAL RBW:1000.000KHz VBW:1000KHz SWT:Auto Detector : Peak Project : 652049 Mode : 5</p>	Left blank

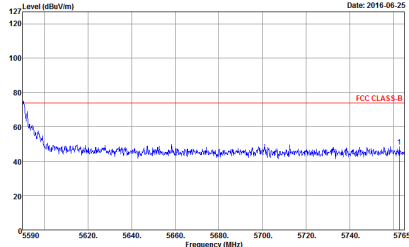
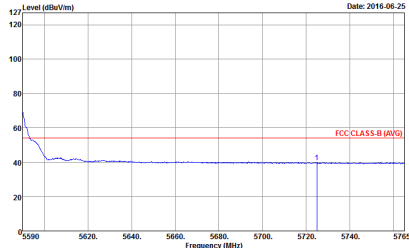

WIFI	Band 3 5470~5725MHz Band Edge @ 3m	
ANT	802.11a CH116 5580MHz - R	
1+2	Horizontal	Fundamental
<p>Peak</p>	 <p>Site : 03CH10-HY Condition : FCC CLASS-B 3m HORN 9120D-HF HORIZONTAL RBW:1000.000kHz VBW:3000.000kHz SWT:Auto Detector : Peak Project : 652049 Mode : 6</p>	<p>Left blank</p>
<p>Avg.</p>	 <p>Site : 03CH10-HY Condition : FCC CLASS-B (AVG) 3m HORN 9120D-HF HORIZONTAL RBW:1000.000kHz VBW:10000-hz SWT:Auto Detector : Peak Project : 652049 Mode : 5</p>	<p>Left blank</p>

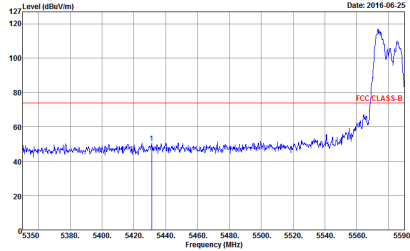
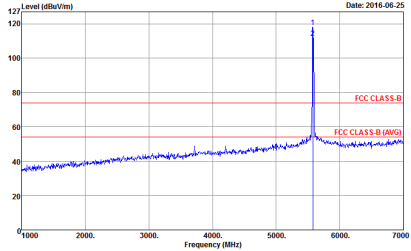
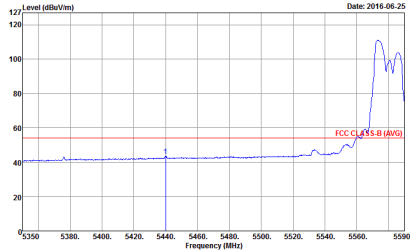

WIFI	Band 3 5470~5725MHz Band Edge @ 3m	
ANT	802.11a CH116 5580MHz - L	
1+2	Vertical	Fundamental
Peak	 <p>Site : 03CH10-HY Condition : FCC CLASS-B 3m HORN 9120D-HF VERTICAL RBW:1000.000KHz VBW:3000.000KHz SWT:Auto Detector : Peak Project : 652049 Mode : 5</p>	 <p>Site : 03CH10-HY Condition : FCC CLASS-B 3m HORN 9120D-HF VERTICAL RBW:1000.000KHz VBW:3000.000KHz SWT:Auto Detector : Peak Project : 652049 Mode : 5</p>
Avg.	 <p>Site : 03CH10-HY Condition : FCC CLASS-B (AVG) 3m HORN 9120D-HF VERTICAL RBW:1000.000KHz VBW:1000KHz SWT:Auto Detector : Peak Project : 652049 Mode : 5</p>	Left blank

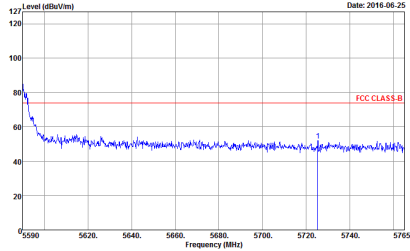
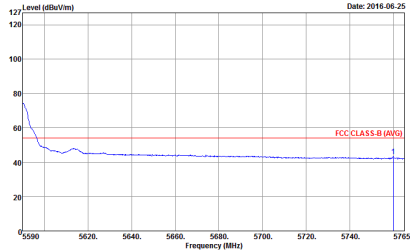

WIFI	Band 3 5470~5725MHz Band Edge @ 3m	
ANT	802.11a CH116 5580MHz - R	
1+2	Vertical	Fundamental
Peak	 <p>Site : 03CH10-HY Condition : FCC CLASS-B 3m HORN 9120D-HF VERTICAL RBW:1000.000kHz VBW:3000.000kHz SWT:Auto Detector : Peak Project : 652049 Mode : 5</p>	Left blank
Avg.	 <p>Site : 03CH10-HY Condition : FCC CLASS-B (AVG) 3m HORN 9120D-HF VERTICAL RBW:1000.000kHz VBW:10000-hz SWT:Auto Detector : Peak Project : 652049 Mode : 5</p>	Left blank

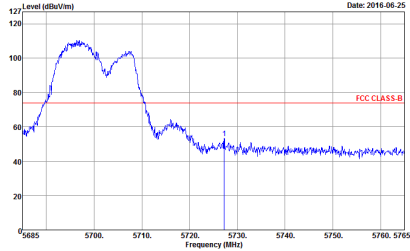
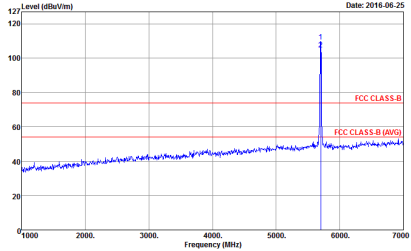
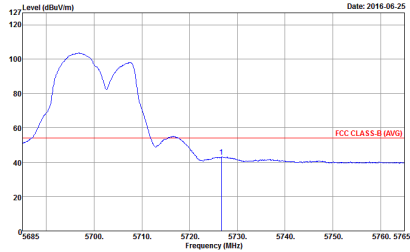

WIFI	Band 3 5470~5725MHz Band Edge @ 3m	
ANT	802.11a CH140 5700MHz	
1+2	Horizontal	Fundamental
Peak	 <p>Site : 03CH10-HY Condition : FCC CLASS-B 3m HORN 9120D-HF HORIZONTAL RBW:1000.000KHz VBW:3000.000KHz SWT:Auto Detector : Peak Project : 652049 Mode : 6</p>	 <p>Site : 03CH10-HY Condition : FCC CLASS-B 3m HORN 9120D-HF HORIZONTAL RBW:1000.000KHz VBW:3000.000KHz SWT:Auto Detector : Peak Project : 652049 Mode : 6</p>
Avg.	 <p>Site : 03CH10-HY Condition : FCC CLASS-B (AVG) 3m HORN 9120D-HF HORIZONTAL RBW:1000.000KHz VBW:10000KHz SWT:Auto Detector : Peak Project : 652049 Mode : 6</p>	Left blank

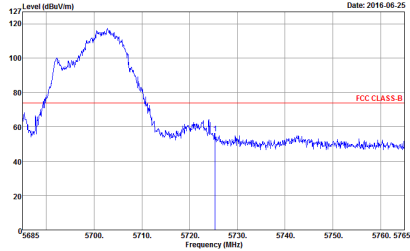
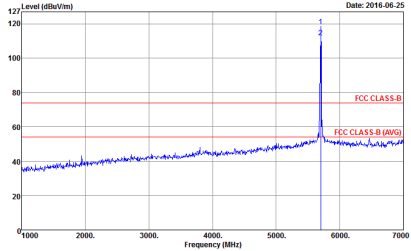
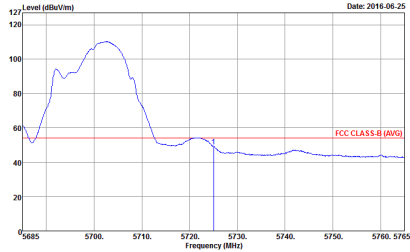

WIFI	Band 3 5470~5725MHz Band Edge @ 3m	
ANT	802.11a CH140 5700MHz	
1+2	Vertical	Fundamental
Peak	 <p>Date: 2016-06-25</p> <p>Site : 03CH10-HY Condition : FCC CLASS-B 3m HORN 9120D-HF VERTICAL RBW:1000.000KHz VBW:3000.000KHz SWT:Auto Detector : Peak Project : 652049 Mode : 6</p>	 <p>Date: 2016-06-25</p> <p>Site : 03CH10-HY Condition : FCC CLASS-B 3m HORN 9120D-HF VERTICAL RBW:1000.000KHz VBW:3000.000KHz SWT:Auto Detector : Peak Project : 652049 Mode : 6</p>
Avg.	 <p>Date: 2016-06-25</p> <p>Site : 03CH10-HY Condition : FCC CLASS-B (AVG) 3m HORN 9120D-HF VERTICAL RBW:1000.000KHz VBW:1000KHz SWT:Auto Detector : Peak Project : 652049 Mode : 6</p>	Left blank

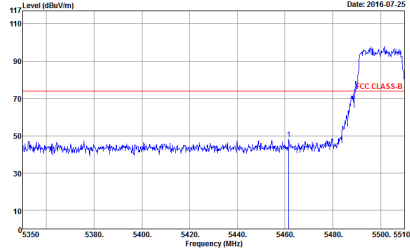
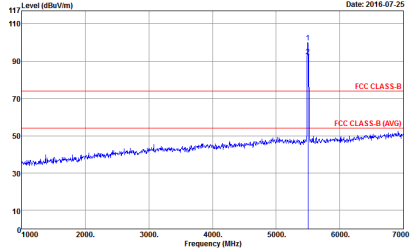
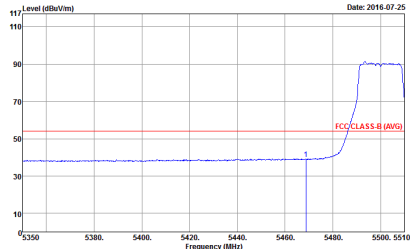

Band 3 5470~5725MHz
WIFI 802.11ac VHT20 (Band Edge @ 3m)

WIFI	Band 3 5470~5725MHz Band Edge @ 3m	
ANT	802.11ac VHT20 CH100 5500MHz	
1+2	Horizontal	Fundamental
<p>Peak</p>	 <p>Date: 2016-07-25</p> <p>Site : 03CH10-HY Condition : FCC CLASS-B 3m HORN 9120D-HF HORIZONTAL RBW:1000.000KHz VBW:3000.000KHz SWT:Auto Detector : Peak Project : 652049-01 Mode : 10</p>	 <p>Date: 2016-07-25</p> <p>Site : 03CH10-HY Condition : FCC CLASS-B 3m HORN 9120D-HF HORIZONTAL RBW:1000.000KHz VBW:3000.000KHz SWT:Auto Detector : Peak Project : 652049-01 Mode : 10</p>
<p>Avg.</p>	 <p>Date: 2016-07-25</p> <p>Site : 03CH10-HY Condition : FCC CLASS-B (AVG) 3m HORN 9120D-HF HORIZONTAL RBW:1000.000KHz VBW:1.000KHz SWT:Auto Detector : Peak Project : 652049-01 Mode : 10</p>	<p align="center">Left blank</p>

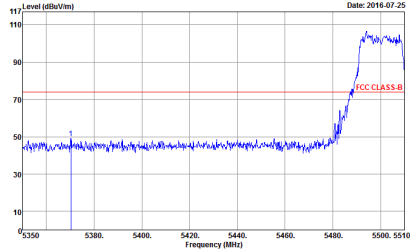
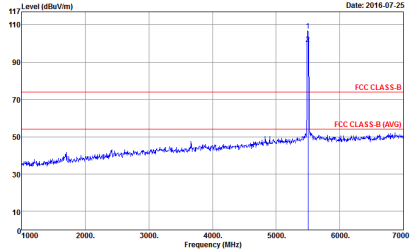
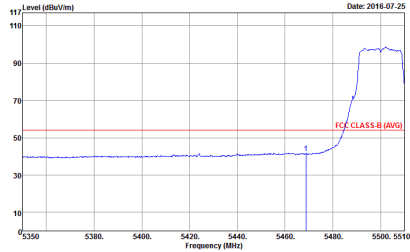

WIFI	Band 3 5470~5725MHz Band Edge @ 3m	
ANT	802.11ac VHT20 CH100 5500MHz	
1+2	Vertical	Fundamental
<p>Peak</p>	 <p>Date: 2016-07-25</p> <p>Site : 03CH10-HY Condition : FCC CLASS-B 3m HORN 9120D-HF VERTICAL RBW:1000.000KHz VBW:3000.000KHz SWT:Auto Detector : Peak Project : 652049-01 Mode : 10</p>	 <p>Date: 2016-07-25</p> <p>Site : 03CH10-HY Condition : FCC CLASS-B 3m HORN 9120D-HF VERTICAL RBW:1000.000KHz VBW:3000.000KHz SWT:Auto Detector : Peak Project : 652049-01 Mode : 10</p>
<p>Avg.</p>	 <p>Date: 2016-07-25</p> <p>Site : 03CH10-HY Condition : FCC CLASS-B (AVG) 3m HORN 9120D-HF VERTICAL RBW:1000.000KHz VBW:1000KHz SWT:Auto Detector : Peak Project : 652049-01 Mode : 10</p>	<p>Left blank</p>

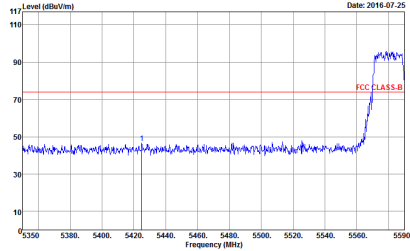
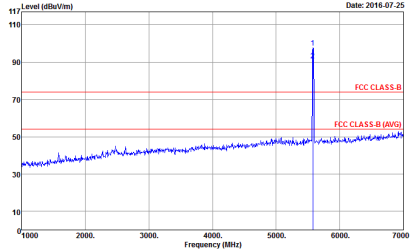
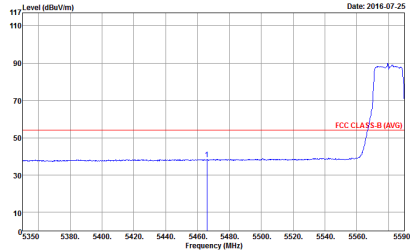

WIFI	Band 3 5470~5725MHz Band Edge @ 3m	
ANT	802.11ac VHT20 CH116 5580MHz - L	
1+2	Horizontal	Fundamental
<p>Peak</p>	 <p>Date: 2016-07-25</p> <p>Site : 03CH10-HY Condition : FCC CLASS-B 3m HORN 9120D-HF HORIZONTAL RBW:1000.000KHz VBW:3000.000KHz SWT:Auto Detector : Peak Project : 652049-01 Mode : II</p>	 <p>Date: 2016-07-25</p> <p>Site : 03CH10-HY Condition : FCC CLASS-B 3m HORN 9120D-HF HORIZONTAL RBW:1000.000KHz VBW:3000.000KHz SWT:Auto Detector : Peak Project : 652049-01 Mode : II</p>
<p>Avg.</p>	 <p>Date: 2016-07-25</p> <p>Site : 03CH10-HY Condition : FCC CLASS-B (AVG) 3m HORN 9120D-HF HORIZONTAL RBW:1000.000KHz VBW:1000KHz SWT:Auto Detector : Peak Project : 652049-01 Mode : II</p>	<p>Left blank</p>

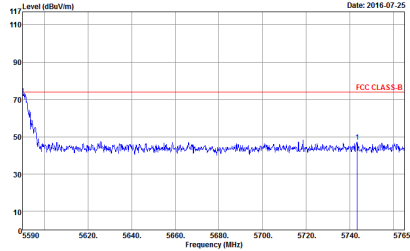
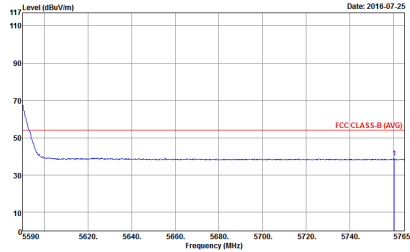

WIFI	Band 3 5470~5725MHz Band Edge @ 3m	
ANT	802.11ac VHT20 CH116 5580MHz - R	
1+2	Horizontal	Fundamental
Peak	 <p>Site : 03CH10-HY Condition : FCC CLASS-B 3m HORN 9120D-HF HORIZONTAL RBW:1000.000kHz VBW:3000.000kHz SWT:Auto Detector : Peak Project : 652049-01 Mode : II</p>	Left blank
Avg.	 <p>Site : 03CH10-HY Condition : FCC CLASS-B (AVG) 3m HORN 9120D-HF HORIZONTAL RBW:1000.000kHz VBW:10000-hz SWT:Auto Detector : Peak Project : 652049-01 Mode : II</p>	Left blank

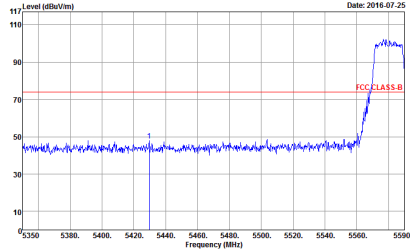
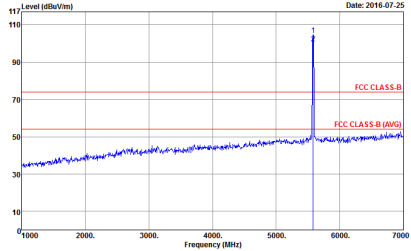
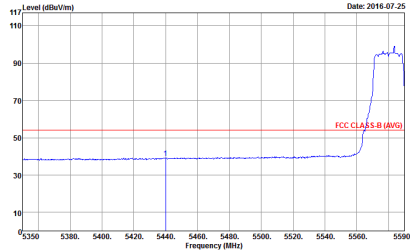

WIFI	Band 3 5470~5725MHz Band Edge @ 3m	
ANT	802.11ac VHT20 CH116 5580MHz - L	
1+2	Vertical	Fundamental
Peak	 <p>Site : 03CH10-HY Condition : FCC CLASS-B 3m HORN 9120D-HF VERTICAL RBW:1000.000KHz VBW:3000.000KHz SWT:Auto Detector : Peak Project : 652049-01 Mode : II</p>	 <p>Site : 03CH10-HY Condition : FCC CLASS-B 3m HORN 9120D-HF VERTICAL RBW:1000.000KHz VBW:3000.000KHz SWT:Auto Detector : Peak Project : 652049-01 Mode : II</p>
Avg.	 <p>Site : 03CH10-HY Condition : FCC CLASS-B (AVG) 3m HORN 9120D-HF VERTICAL RBW:1000.000KHz VBW:10000KHz SWT:Auto Detector : Peak Project : 652049-01 Mode : II</p>	Left blank

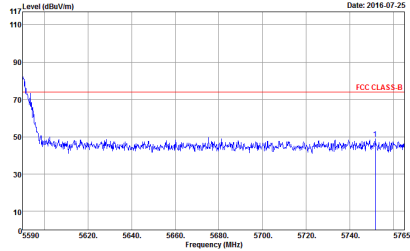
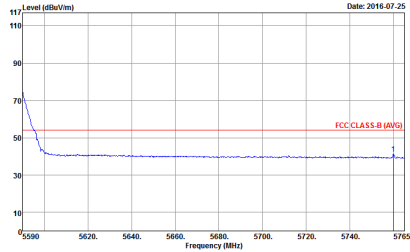

WIFI	Band 3 5470~5725MHz Band Edge @ 3m	
ANT	802.11ac VHT20 CH116 5580MHz - R	
1+2	Vertical	Fundamental
<p>Peak</p>	 <p>Site : 03CH10-HY Condition : FCC CLASS-B 3m HORN 9120D-HF VERTICAL RBW:1000.000kHz VBW:3000.000kHz SWT:Auto Detector : Peak Project : 652049-01 Mode : II</p>	<p>Left blank</p>
<p>Avg.</p>	 <p>Site : 03CH10-HY Condition : FCC CLASS-B (AVG) 3m HORN 9120D-HF VERTICAL RBW:1000.000kHz VBW:10000-hz SWT:Auto Detector : Peak Project : 652049-01 Mode : II</p>	<p>Left blank</p>

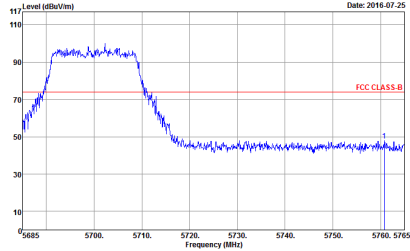
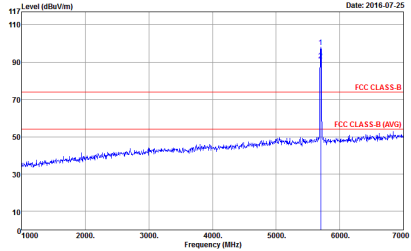
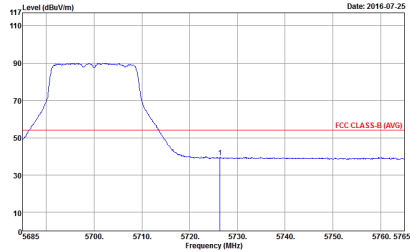

WIFI	Band 3 5470~5725MHz Band Edge @ 3m	
ANT	802.11ac VHT20 CH140 5700MHz	
1+2	Horizontal	Fundamental
Peak	 <p>Date: 2016-07-25</p> <p>Site : 03CH10-HY Condition : FCC CLASS-B 3m HORN 9120D-HF HORIZONTAL RBW:1000.000kHz VBW:3000.000kHz SWT:Auto Detector : Peak Project : 652049-01 Mode : 12</p>	 <p>Date: 2016-07-25</p> <p>Site : 03CH10-HY Condition : FCC CLASS-B 3m HORN 9120D-HF HORIZONTAL RBW:1000.000kHz VBW:3000.000kHz SWT:Auto Detector : Peak Project : 652049-01 Mode : 12</p>
Avg.	 <p>Date: 2016-07-25</p> <p>Site : 03CH10-HY Condition : FCC CLASS-B (AVG) 3m HORN 9120D-HF HORIZONTAL RBW:1000.000kHz VBW:10000-hz SWT:Auto Detector : Peak Project : 652049-01 Mode : 12</p>	Left blank

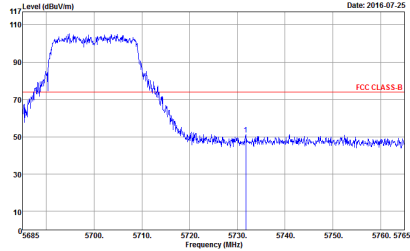
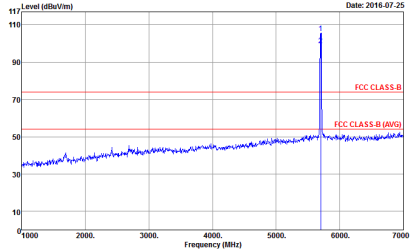
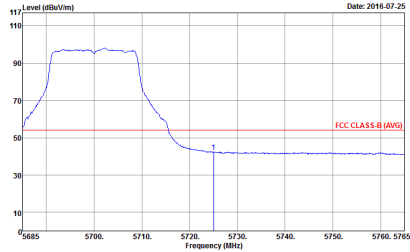

WIFI	Band 3 5470~5725MHz Band Edge @ 3m	
ANT	802.11ac VHT20 CH140 5700MHz	
1+2	Vertical	Fundamental
Peak	 <p>Site : 03CH10-HY Condition : FCC CLASS-B 3m HORN 9120D-HF VERTICAL RBW:1000.000kHz VBW:3000.000kHz SWT:Auto Detector : Peak Project : 652049-01 Mode : 12</p>	 <p>Site : 03CH10-HY Condition : FCC CLASS-B 3m HORN 9120D-HF VERTICAL RBW:1000.000kHz VBW:3000.000kHz SWT:Auto Detector : Peak Project : 652049-01 Mode : 12</p>
Avg.	 <p>Site : 03CH10-HY Condition : FCC CLASS-B (AVG) 3m HORN 9120D-HF VERTICAL RBW:1000.000kHz VBW:10000Hz SWT:Auto Detector : Peak Project : 652049-01 Mode : 12</p>	Left blank

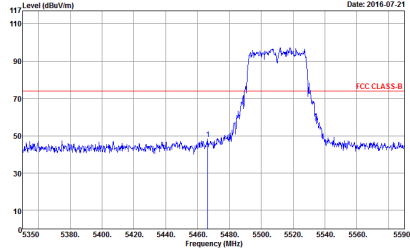
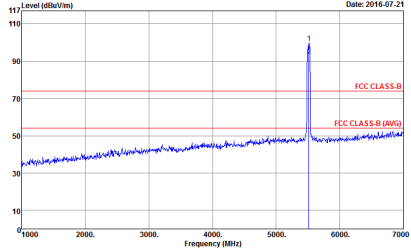
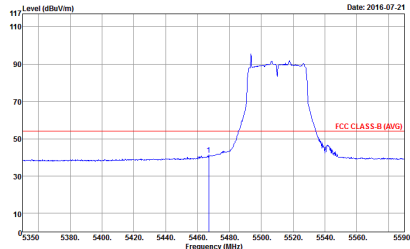

**Band 3 5470~5725MHz
WIFI 802.11ac VHT40 (Band Edge @ 3m)**

WIFI	Band 3 5470~5725MHz Band Edge @ 3m	
ANT	802.11ac VHT40 CH102 5510MHz - L	
1+2	Horizontal	Fundamental
<p>Peak</p>	 <p>Date: 2016-07-21</p> <p>Site : 03CH10-HY Condition : FCC CLASS-B 3m HORN 9120D-HF HORIZONTAL RBW:1000.000KHz VBW:3000.000KHz SWT:Auto Detector : Peak Project : 652049-01 Mode : 15</p>	 <p>Date: 2016-07-21</p> <p>Site : 03CH10-HY Condition : FCC CLASS-B 3m HORN 9120D-HF HORIZONTAL RBW:1000.000KHz VBW:3000.000KHz SWT:Auto Detector : Peak Project : 652049-01 Mode : 15</p>
<p>Avg.</p>	 <p>Date: 2016-07-21</p> <p>Site : 03CH10-HY Condition : FCC CLASS-B (AVG) 3m HORN 9120D-HF HORIZONTAL RBW:1000.000KHz VBW:1.000KHz SWT:Auto Detector : Peak Project : 652049-01 Mode : 15</p>	<p align="center">Left blank</p>



WIFI	Band 3 5470~5725MHz Band Edge @ 3m	
ANT	802.11ac VHT40 CH102 5510MHz - R	
1+2	Horizontal	Fundamental
Peak	<p>Site : 03CH10-HY Condition : FCC CLASS-B 3m HORN 9120D-HF HORIZONTAL RBW:1000.000kHz VBW:3000.000kHz SWT:Auto Detector : Peak Project : 652049-01 Mode : 15</p>	Left blank
Avg.	<p>Site : 03CH10-HY Condition : FCC CLASS-B (AVG) 3m HORN 9120D-HF HORIZONTAL RBW:1000.000kHz VBW:10000-hz SWT:Auto Detector : Peak Project : 652049-01 Mode : 15</p>	Left blank

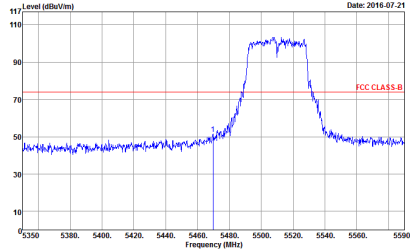
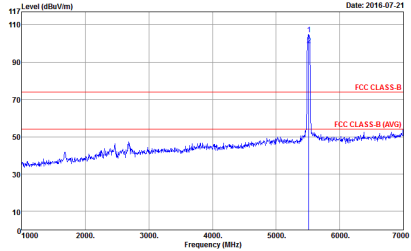
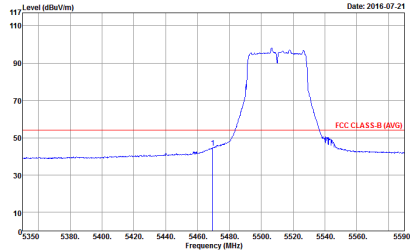

WIFI	Band 3 5470~5725MHz Band Edge @ 3m	
ANT	802.11ac VHT40 CH102 5510MHz - L	
1+2	Vertical	Fundamental
Peak	 <p>Site : 03CH10-HY Condition : FCC CLASS-B 3m HORN 9120D-HF VERTICAL RBW:1000.000KHz VBW:3000.000KHz SWT:Auto Detector : Peak Project : 652049-01 Mode : 15</p>	 <p>Site : 03CH10-HY Condition : FCC CLASS-B 3m HORN 9120D-HF VERTICAL RBW:1000.000KHz VBW:3000.000KHz SWT:Auto Detector : Peak Project : 652049-01 Mode : 15</p>
Avg.	 <p>Site : 03CH10-HY Condition : FCC CLASS-B (AVG) 3m HORN 9120D-HF VERTICAL RBW:1000.000KHz VBW:10000KHz SWT:Auto Detector : Peak Project : 652049-01 Mode : 15</p>	Left blank

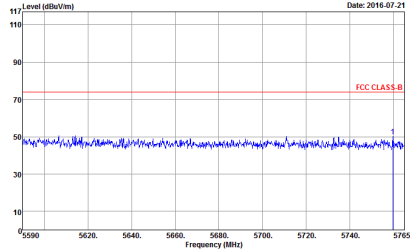
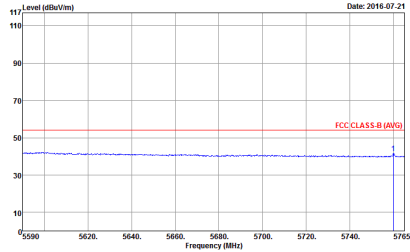

WIFI	Band 3 5470~5725MHz Band Edge @ 3m	
ANT	802.11ac VHT40 CH102 5510MHz - R	
1+2	Vertical	Fundamental
<p>Peak</p>	 <p>Site : 03CH10-HY Condition : FCC CLASS-B 3m HORN 9120D-HF VERTICAL RBW:1000.000kHz VBW:3000.000kHz SWT:Auto Detector : Peak Project : 652049-01 Mode : 15</p>	<p>Left blank</p>
<p>Avg.</p>	 <p>Site : 03CH10-HY Condition : FCC CLASS-B (AVG) 3m HORN 9120D-HF VERTICAL RBW:1000.000kHz VBW:10000-hz SWT:Auto Detector : Peak Project : 652049-01 Mode : 15</p>	<p>Left blank</p>

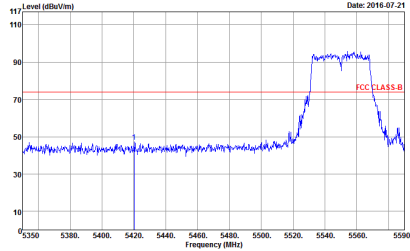
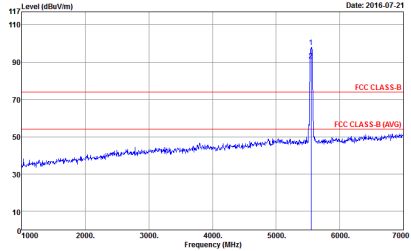
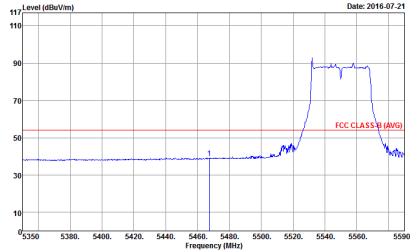

WIFI	Band 3 5470~5725MHz Band Edge @ 3m	
ANT	802.11ac VHT40 CH110 5550MHz - L	
1+2	Horizontal	Fundamental
Peak	 <p>Date: 2016-07-21</p> <p>Site : 03CH10-HY Condition : FCC CLASS-B 3m HORN 9120D-HF HORIZONTAL RBW:1000.000kHz VBW:3000.000kHz SWT:Auto Detector : Peak Project : 652049-01 Mode : 16</p>	 <p>Date: 2016-07-21</p> <p>Site : 03CH10-HY Condition : FCC CLASS-B 3m HORN 9120D-HF HORIZONTAL RBW:1000.000kHz VBW:3000.000kHz SWT:Auto Detector : Peak Project : 652049-01 Mode : 16</p>
Avg.	 <p>Date: 2016-07-21</p> <p>Site : 03CH10-HY Condition : FCC CLASS-B (AVG) 3m HORN 9120D-HF HORIZONTAL RBW:1000.000kHz VBW:10000-hz SWT:Auto Detector : Peak Project : 652049-01 Mode : 16</p>	Left blank

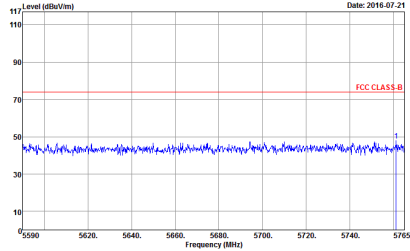
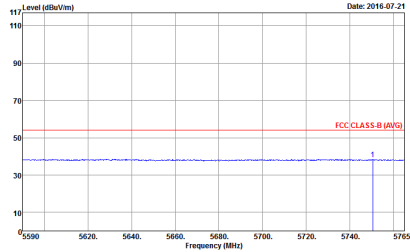

WIFI	Band 3 5470~5725MHz Band Edge @ 3m	
ANT	802.11ac VHT40 CH110 5550MHz - R	
1+2	Horizontal	Fundamental
Peak	 <p> Site : 03CH10-HY Condition : FCC CLASS-B 3m HORN 9120D-HF HORIZONTAL Detector : Peak Project : 652049-01 Mode : 16 </p>	Left blank
Avg.	 <p> Site : 03CH10-HY Condition : FCC CLASS-B (AVG) 3m HORN 9120D-HF HORIZONTAL Detector : Peak Project : 652049-01 Mode : 16 </p>	Left blank



WIFI	Band 3 5470~5725MHz Band Edge @ 3m	
ANT	802.11ac VHT40 CH110 5550MHz - L	
1+2	Vertical	Fundamental
<p>Peak</p>	<p>Site : 03CH10-HY Condition : FCC CLASS-B 3m HORN 9120D-HF VERTICAL RBW:1000.000KHz VBW:3000.000KHz SWT:Auto Detector : Peak Project : 652049-01 Mode : 16</p>	<p>Site : 03CH10-HY Condition : FCC CLASS-B 3m HORN 9120D-HF VERTICAL RBW:1000.000KHz VBW:3000.000KHz SWT:Auto Detector : Peak Project : 652049-01 Mode : 16</p>
<p>Avg.</p>	<p>Site : 03CH10-HY Condition : FCC CLASS-B (AVG) 3m HORN 9120D-HF VERTICAL RBW:1000.000KHz VBW:1000KHz SWT:Auto Detector : Peak Project : 652049-01 Mode : 16</p>	<p>Left blank</p>

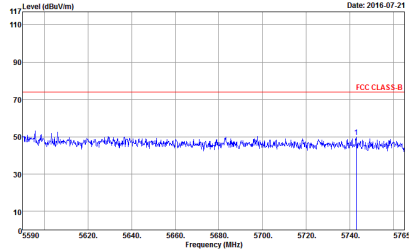
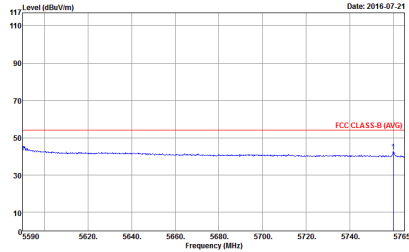

WIFI	Band 3 5470~5725MHz Band Edge @ 3m	
ANT	802.11ac VHT40 CH110 5550MHz - R	
1+2	Vertical	Fundamental
Peak	 <p>Date: 2016-07-21</p> <p>Site : 03CH10-HY Condition : FCC CLASS-B 3m HORN 9120D-HF VERTICAL RBW:1000.000kHz VBW:3000.000kHz SWT:Auto Detector : Peak Project : 652049-01 Mode : 16</p>	Left blank
Avg.	 <p>Date: 2016-07-21</p> <p>Site : 03CH10-HY Condition : FCC CLASS-B (AVG) 3m HORN 9120D-HF VERTICAL RBW:1000.000kHz VBW:10000-hz SWT:Auto Detector : Peak Project : 652049-01 Mode : 16</p>	Left blank

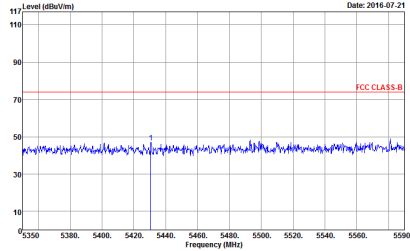
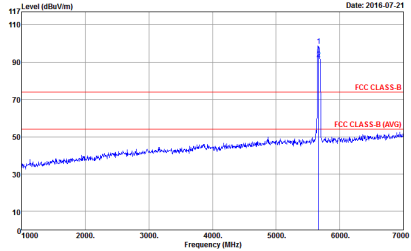
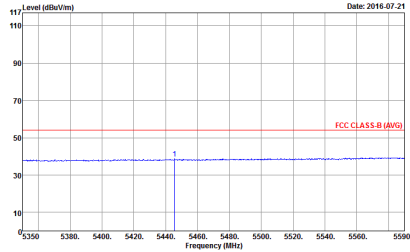

WIFI	Band 3 5470~5725MHz Band Edge @ 3m	
ANT	802.11ac VHT40 CH134 5670MHz - L	
1+2	Horizontal	Fundamental
Peak	 <p>Date: 2016-07-21</p> <p>Site : 03CH10-HY Condition : FCC CLASS-B 3m HORN 9120D-HF HORIZONTAL RBW:1000.000kHz VBW:3000.000kHz SWT:Auto Detector : Peak Project : 652049-01 Mode : 17</p>	 <p>Date: 2016-07-21</p> <p>Site : 03CH10-HY Condition : FCC CLASS-B 3m HORN 9120D-HF HORIZONTAL RBW:1000.000kHz VBW:3000.000kHz SWT:Auto Detector : Peak Project : 652049-01 Mode : 17</p>
Avg.	 <p>Date: 2016-07-21</p> <p>Site : 03CH10-HY Condition : FCC CLASS-B (AVG) 3m HORN 9120D-HF HORIZONTAL RBW:1000.000kHz VBW:10000-hz SWT:Auto Detector : Peak Project : 652049-01 Mode : 17</p>	Left blank

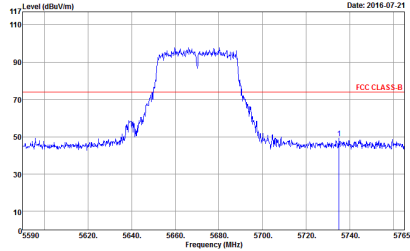
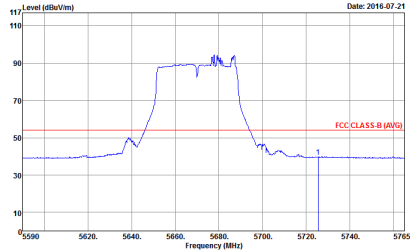

WIFI	Band 3 5470~5725MHz Band Edge @ 3m	
ANT	802.11ac VHT40 CH134 5670MHz - R	
1+2	Horizontal	Fundamental
Peak	 <p>Site : 03CH10-HY Condition : FCC CLASS-B 3m HORN 9120D-HF HORIZONTAL RBW:1000.000kHz VBW:3000.000kHz SWT:Auto Detector : Peak Project : 652049-01 Mode : 17</p>	Left blank
Avg.	 <p>Site : 03CH10-HY Condition : FCC CLASS-B (AVG) 3m HORN 9120D-HF HORIZONTAL RBW:1000.000kHz VBW:10000-hz SWT:Auto Detector : Peak Project : 652049-01 Mode : 17</p>	Left blank

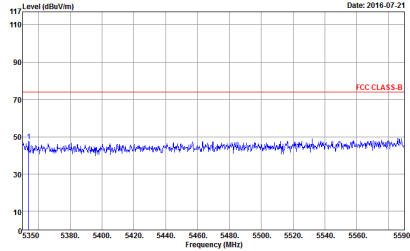
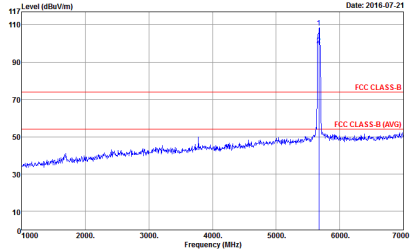
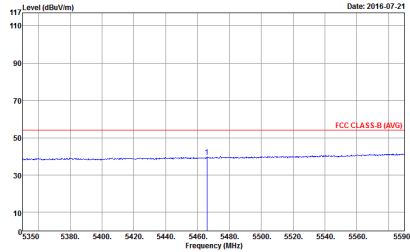

WIFI	Band 3 5470~5725MHz Band Edge @ 3m	
ANT	802.11ac VHT40 CH134 5670MHz - L	
1+2	Vertical	Fundamental
Peak	 <p>Site : 03CH10-HY Condition : FCC CLASS-B 3m HORN 9120D-HF VERTICAL RBW:1000.000KHz VBW:3000.000KHz SWT:Auto Detector : Peak Project : 652049-01 Mode : 17</p>	 <p>Site : 03CH10-HY Condition : FCC CLASS-B 3m HORN 9120D-HF VERTICAL RBW:1000.000KHz VBW:3000.000KHz SWT:Auto Detector : Peak Project : 652049-01 Mode : 17</p>
Avg.	 <p>Site : 03CH10-HY Condition : FCC CLASS-B (AVG) 3m HORN 9120D-HF VERTICAL RBW:1000.000KHz VBW:1000KHz SWT:Auto Detector : Peak Project : 652049-01 Mode : 17</p>	Left blank



WIFI	Band 3 5470~5725MHz Band Edge @ 3m	
ANT	802.11ac VHT40 CH134 5670MHz - R	
1+2	Vertical	Fundamental
<p>Peak</p>	<p>Site : 03CH10-HY Condition : FCC CLASS-B 3m HORN 9120D-HF VERTICAL RBW:1000.000kHz VBW:3000.000kHz SWT:Auto Detector : Peak Project : 652049-01 Mode : 17</p>	<p>Left blank</p>
<p>Avg.</p>	<p>Site : 03CH10-HY Condition : FCC CLASS-B (AVG) 3m HORN 9120D-HF VERTICAL RBW:1000.000kHz VBW:10000-hz SWT:Auto Detector : Peak Project : 652049-01 Mode : 17</p>	<p>Left blank</p>

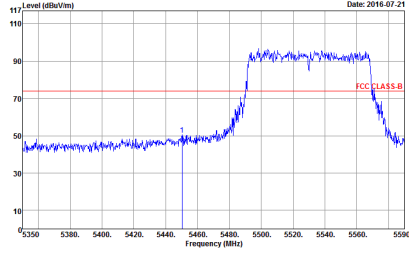
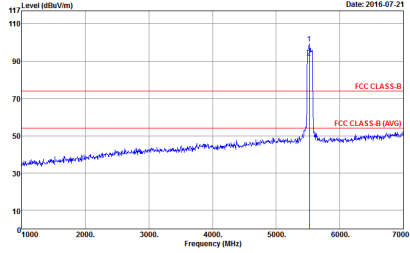
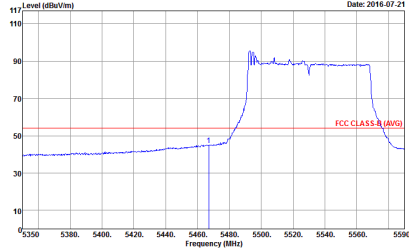

**Band 3 5470~5725MHz
WIFI 802.11ac VHT80 (Band Edge @ 3m)**

WIFI	Band 3 5470~5725MHz Band Edge @ 3m	
ANT	802.11ac VHT80 CH106 5530MHz - L	
1+2	Horizontal	Fundamental
<p>Peak</p>	 <p>Date: 2016-07-21</p> <p>Site : 03CH10-HY Condition : FCC CLASS-B 3m HORN 9120D-HF HORIZONTAL RBW:1000.000KHz VBW:3000.000KHz SWT:Auto Detector : Peak Project : 652049-01 Mode : 19</p>	 <p>Date: 2016-07-21</p> <p>Site : 03CH10-HY Condition : FCC CLASS-B 3m HORN 9120D-HF HORIZONTAL RBW:1000.000KHz VBW:3000.000KHz SWT:Auto Detector : Peak Project : 652049-01 Mode : 19</p>
<p>Avg.</p>	 <p>Date: 2016-07-21</p> <p>Site : 03CH10-HY Condition : FCC CLASS-B (AVG) 3m HORN 9120D-HF HORIZONTAL RBW:1000.000KHz VBW:3.000KHz SWT:Auto Detector : Peak Project : 652049-01 Mode : 19</p>	<p align="center">Left blank</p>



WIFI	Band 3 5470~5725MHz Band Edge @ 3m	
ANT	802.11ac VHT80 CH106 5530MHz - R	
1+2	Horizontal	Fundamental
Peak	<p>Site : 03CH10-HY Condition : FCC CLASS-B 3m HORN 9120D-HF HORIZONTAL RBW:1000.000kHz VBW:3000.000kHz SWT:Auto Detector : Peak Project : 652049-01 Mode : 19</p>	Left blank
Avg.	<p>Site : 03CH10-HY Condition : FCC CLASS-B (AVG) 3m HORN 9120D-HF HORIZONTAL RBW:1000.000kHz VBW:3.000kHz SWT:Auto Detector : Peak Project : 652049-01 Mode : 19</p>	Left blank

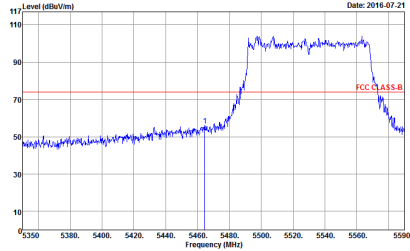
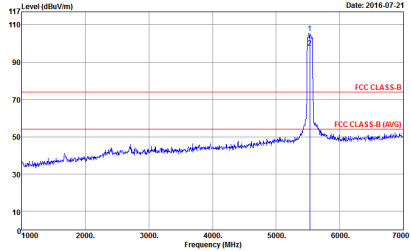
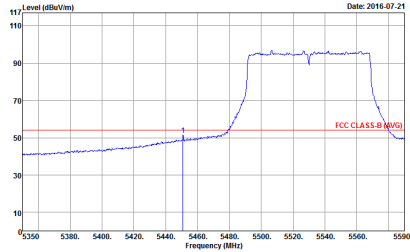

WIFI	Band 3 5470~5725MHz Band Edge @ 3m	
ANT	802.11ac VHT80 CH106 5530MHz - L	
1+2	Vertical	Fundamental
Peak	 <p>Date: 2016-07-21</p> <p>Site : 03CH10-HY Condition : FCC CLASS-B 3m HORN 9120D-HF VERTICAL RBW:1000.000KHz VBW:3000.000KHz SWT:Auto Detector : Peak Project : 652049-01 Mode : 19</p>	 <p>Date: 2016-07-21</p> <p>Site : 03CH10-HY Condition : FCC CLASS-B 3m HORN 9120D-HF VERTICAL RBW:1000.000KHz VBW:3000.000KHz SWT:Auto Detector : Peak Project : 652049-01 Mode : 19</p>
Avg.	 <p>Date: 2016-07-21</p> <p>Site : 03CH10-HY Condition : FCC CLASS-B (AVG) 3m HORN 9120D-HF VERTICAL RBW:1000.000KHz VBW:3.000KHz SWT:Auto Detector : Peak Project : 652049-01 Mode : 19</p>	Left blank



WIFI	Band 3 5470~5725MHz Band Edge @ 3m	
ANT	802.11ac VHT80 CH106 5530MHz - R	
1+2	Vertical	Fundamental
<p>Peak</p>	<p>Date: 2016-07-21</p> <p>Site : 03CH10-HY Condition : FCC CLASS-B 3m HORN 9120D-HF VERTICAL RBW:1000.000KHz VBW:3000.000KHz SWT:Auto Detector : Peak Project : 652049-01 Mode : 19</p>	<p>Left blank</p>
<p>Avg.</p>	<p>Date: 2016-07-21</p> <p>Site : 03CH10-HY Condition : FCC CLASS-B (AVG) 3m HORN 9120D-HF VERTICAL RBW:1000.000KHz VBW:3.000KHz SWT:Auto Detector : Peak Project : 652049-01 Mode : 19</p>	<p>Left blank</p>



WIFI	Band 3 5470~5725MHz Band Edge @ 3m	
ANT	802.11ac VHT80 CH122 5610MHz - L	
1+2	Horizontal	Fundamental
<p>Peak</p>	<p>Site : 03CH10-HY Condition : FCC CLASS-B 3m HORN 9120D-HF HORIZONTAL RBW:1000.000kHz VBW:3000.000kHz SWT:Auto Detector : Peak Project : 652049-01 Mode : 20</p>	<p>Site : 03CH10-HY Condition : FCC CLASS-B 3m HORN 9120D-HF HORIZONTAL RBW:1000.000kHz VBW:3000.000kHz SWT:Auto Detector : Peak Project : 652049-01 Mode : 20</p>
<p>Avg.</p>	<p>Site : 03CH10-HY Condition : FCC CLASS-B (AVG) 3m HORN 9120D-HF HORIZONTAL RBW:1000.000kHz VBW:3.000kHz SWT:Auto Detector : Peak Project : 652049-01 Mode : 20</p>	<p>Left blank</p>

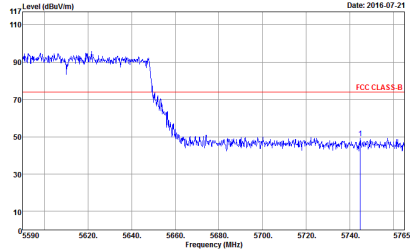
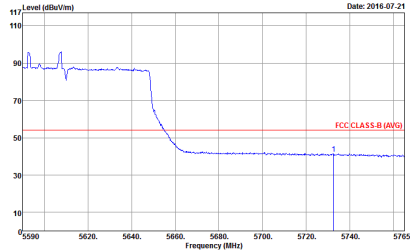

WIFI	Band 3 5470~5725MHz Band Edge @ 3m	
ANT	802.11ac VHT80 CH122 5610MHz - R	
1+2	Horizontal	Fundamental
Peak	 <p>Site : 03CH10-HY Condition : FCC CLASS-B 3m HORN 9120D-HF HORIZONTAL RBW:1000.000kHz VBW:3000.000kHz SWT:Auto Detector : Peak Project : 652049-01 Mode : 20</p>	Left blank
Avg.	 <p>Site : 03CH10-HY Condition : FCC CLASS-B (AVG) 3m HORN 9120D-HF HORIZONTAL RBW:1000.000kHz VBW:3.000kHz SWT:Auto Detector : Peak Project : 652049-01 Mode : 20</p>	Left blank

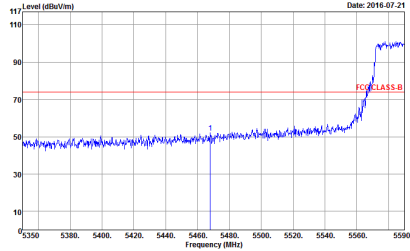
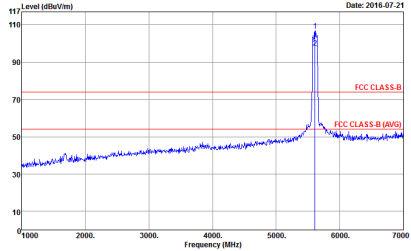
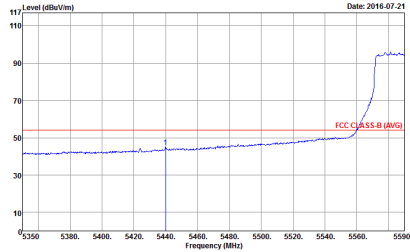

WIFI	Band 3 5470~5725MHz Band Edge @ 3m	
ANT	802.11ac VHT80 CH122 5610MHz - L	
1+2	Vertical	Fundamental
Peak	 <p>Date: 2016-07-21</p> <p>Site : 03CH10-HY Condition : FCC CLASS-B 3m HORN 9120D-HF VERTICAL RBW:1000.000KHz VBW:3000.000KHz SWT:Auto Detector : Peak Project : 652049-01 Mode : 20</p>	 <p>Date: 2016-07-21</p> <p>Site : 03CH10-HY Condition : FCC CLASS-B 3m HORN 9120D-HF VERTICAL RBW:1000.000KHz VBW:3000.000KHz SWT:Auto Detector : Peak Project : 652049-01 Mode : 20</p>
Avg.	 <p>Date: 2016-07-21</p> <p>Site : 03CH10-HY Condition : FCC CLASS-B (AVG) 3m HORN 9120D-HF VERTICAL RBW:1000.000KHz VBW:3.000KHz SWT:Auto Detector : Peak Project : 652049-01 Mode : 20</p>	Left blank

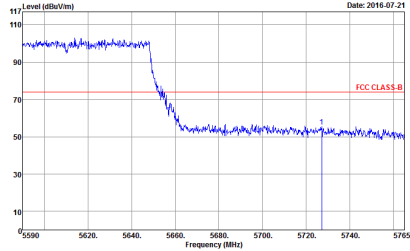
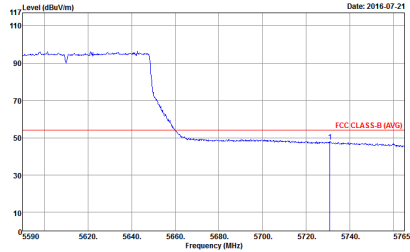

WIFI	Band 3 5470~5725MHz Band Edge @ 3m	
ANT	802.11ac VHT80 CH122 5610MHz - R	
1+2	Vertical	Fundamental
Peak	 <p>Site : 03CH10-HY Condition : FCC CLASS-B 3m HORN 9120D-HF VERTICAL RBW:1000.000KHz VBW:3000.000KHz SWT:Auto Detector : Peak Project : 652049-01 Mode : 20</p>	Left blank
Avg.	 <p>Site : 03CH10-HY Condition : FCC CLASS-B (AVG) 3m HORN 9120D-HF VERTICAL RBW:1000.000KHz VBW:3.000KHz SWT:Auto Detector : Peak Project : 652049-01 Mode : 20</p>	Left blank



Band 3 - 5470~5725MHz
WIFI 802.11a (Harmonic @ 3m)

WIFI	Band 3 5470~5725MHz Harmonic @ 3m	
ANT	802.11a CH100 5500MHz	
1+2	Horizontal	Vertical
Peak Avg.	<p>Site : 03CH10-HY Condition : FCC CLASS-B 3m HORN 9120D-HF HORIZONTAL Detector : Peak Project : 652049 Mode : 4</p>	<p>Site : 03CH10-HY Condition : FCC CLASS-B 3m HORN 9120D-HF VERTICAL Detector : Peak Project : 652049 Mode : 4</p>

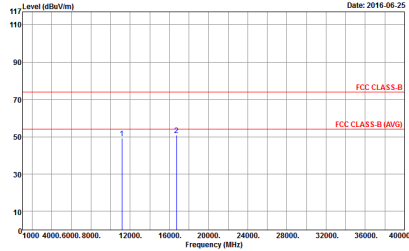
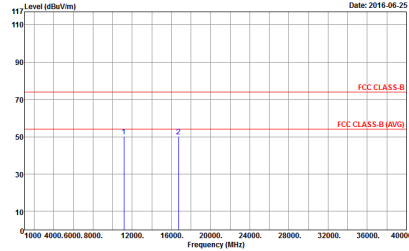

WIFI	Band 3 5470~5725MHz Harmonic @ 3m	
ANT	802.11a CH116 5580MHz	
1+2	Horizontal	Vertical
Peak Avg.	 <p>Site : 08CH10-HY Condition : FCC CLASS-B 3m HORN 9120D-HF HORIZONTAL Detector : Peak Project : 652049 Mode : 5</p>	 <p>Site : 08CH10-HY Condition : FCC CLASS-B 3m HORN 9120D-HF VERTICAL Detector : Peak Project : 652049 Mode : 5</p>

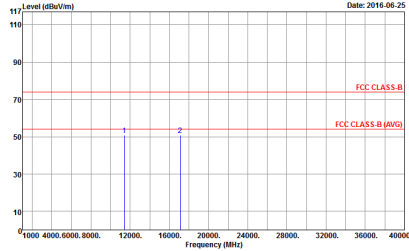
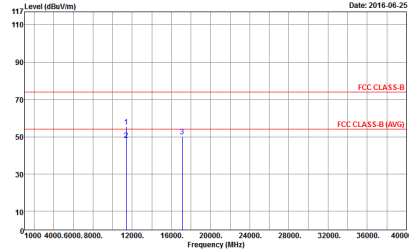

WIFI	Band 3 5470~5725MHz Harmonic @ 3m	
ANT	802.11a CH140 5700MHz	
1+2	Horizontal	Vertical
Peak Avg.	 <p>Site : 08CH10-HY Condition : FCC CLASS-B 3m HORN 9120D-HF HORIZONTAL Detector : Peak Project : 652049 Mode : 6</p>	 <p>Site : 08CH10-HY Condition : FCC CLASS-B 3m HORN 9120D-HF VERTICAL Detector : Peak Project : 652049 Mode : 6</p>

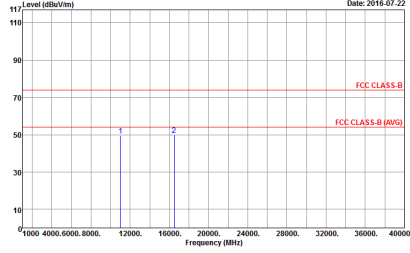
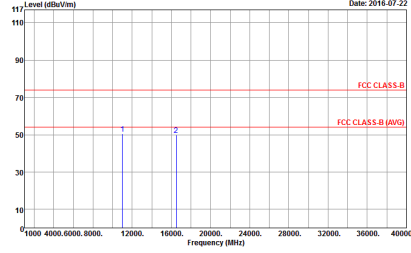

Band 3 5470~5725MHz
WIFI 802.11ac VHT20 (Harmonic @ 3m)

WIFI	Band 3 5470~5725MHz Harmonic @ 3m	
ANT	802.11ac VHT20 CH100 5500MHz	
1+2	Horizontal	Vertical
Peak Avg.	 <p>Date: 2016-07-22</p> <p>Site : 03CH10-HY Condition : FCC CLASS-B 3m HORN 9120D-HF HORIZONTAL Detector : Peak Project : 652049 Mode : 10</p>	 <p>Date: 2016-07-22</p> <p>Site : 03CH10-HY Condition : FCC CLASS-B 3m HORN 9120D-HF VERTICAL Detector : Peak Project : 652049-01 Mode : 10</p>

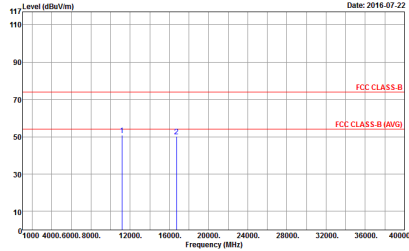
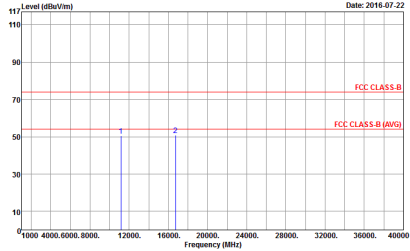

WIFI	Band 3 5470~5725MHz Harmonic @ 3m	
ANT	802.11ac VHT20 CH116 5580MHz	
1+2	Horizontal	Vertical
Peak Avg.	 <p>Site : 08CH10-HY Condition : FCC CLASS-B 3m HORN 9120D-HF HORIZONTAL Detector : Peak Project : 652049-01 Mode : 11</p>	 <p>Site : 08CH10-HY Condition : FCC CLASS-B 3m HORN 9120D-HF VERTICAL Detector : Peak Project : 652049-01 Mode : 11</p>

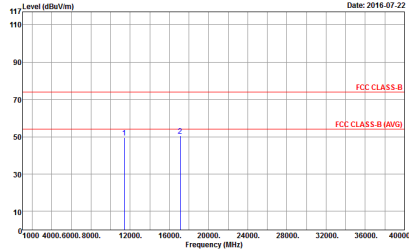
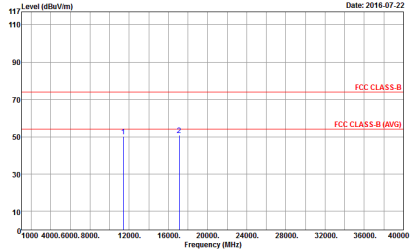

WIFI	Band 3 5470~5725MHz Harmonic @ 3m	
ANT	802.11ac VHT20 CH140 5700MHz	
1+2	Horizontal	Vertical
Peak Avg.	 <p>Site : 08CH10-HY Condition : FCC CLASS-B 3m HORN 9120D-HF HORIZONTAL Detector : Peak Project : 652049-01 Mode : 12</p>	 <p>Site : 08CH10-HY Condition : FCC CLASS-B 3m HORN 9120D-HF VERTICAL Detector : Peak Project : 652049-01 Mode : 12</p>

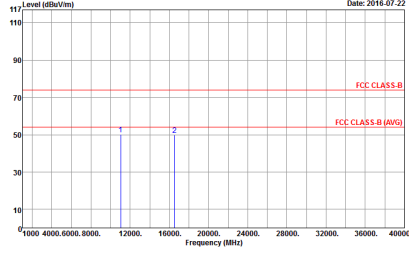
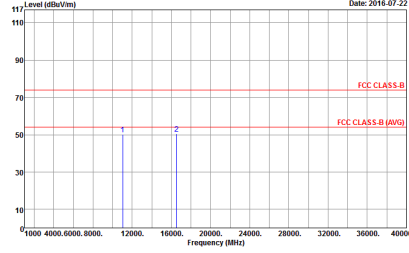

**Band 3 5470~5725MHz
WIFI 802.11ac VHT40 (Harmonic @ 3m)**

WIFI	Band 3 5470~5725MHz Harmonic @ 3m	
ANT	802.11ac VHT40 CH102 5510MHz	
1+2	Horizontal	Vertical
<p>Peak</p> <p>Avg.</p>	 <p>Date: 2016-07-22</p> <p>Site : 03CH10-HY Condition : FCC CLASS-B 3m HORN 9120D-HF HORIZONTAL Detector : Peak Project : 652049-01 Mode : 15</p>	 <p>Date: 2016-07-22</p> <p>Site : 03CH10-HY Condition : FCC CLASS-B 3m HORN 9120D-HF VERTICAL Detector : Peak Project : 652049-01 Mode : 15</p>

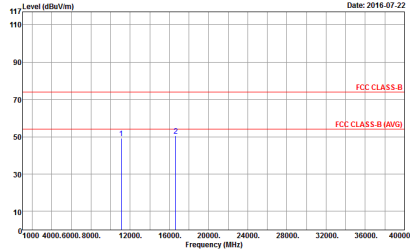
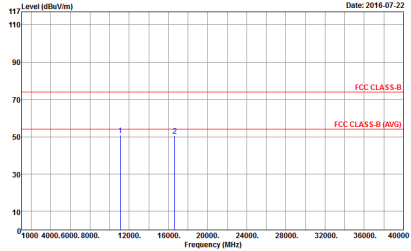

WIFI	Band 3 5470~5725MHz Harmonic @ 3m	
ANT	802.11ac VHT40 CH110 5550MHz	
1+2	Horizontal	Vertical
Peak Avg.	 <p>Site : 08CH10-HY Condition : FCC CLASS-B 3m HORN 9120D-HF HORIZONTAL Detector : Peak Project : 652049-01 Mode : 16</p>	 <p>Site : 08CH10-HY Condition : FCC CLASS-B 3m HORN 9120D-HF VERTICAL Detector : Peak Project : 652049-01 Mode : 16</p>

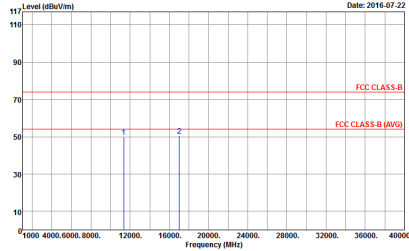
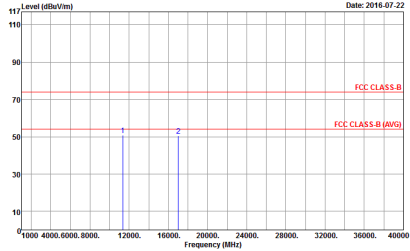

WIFI	Band 3 5470~5725MHz Harmonic @ 3m	
ANT	802.11ac VHT40 CH134 5670MHz	
1+2	Horizontal	Vertical
Peak Avg.	 <p>Site : 08CH10-HY Condition : FCC CLASS-B 3m HORN 9120D-HF HORIZONTAL Detector : Peak Project : 652049-01 Mode : 17</p>	 <p>Site : 08CH10-HY Condition : FCC CLASS-B 3m HORN 9120D-HF VERTICAL Detector : Peak Project : 652049-01 Mode : 17</p>

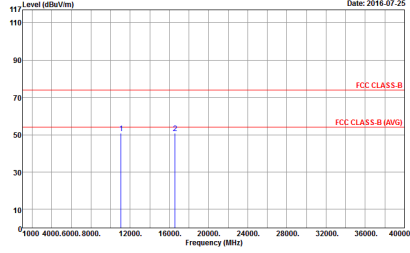
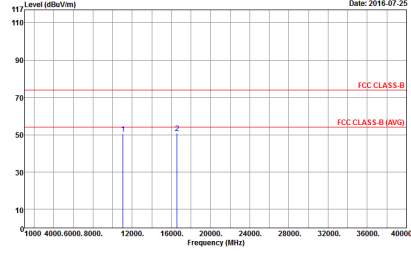

**Band 3 5470~5725MHz
WIFI 802.11ac VHT80 (Harmonic @ 3m)**

WIFI	Band 3 5470~5725MHz Harmonic @ 3m	
ANT	802.11ac VHT80 CH106 5530MHz	
1+2	Horizontal	Vertical
<p>Peak</p> <p>Avg.</p>	 <p>Date: 2016-07-25</p> <p>Site : 03CH10-HY Condition : FCC CLASS-B 3m HORN 9120D-HF HORIZONTAL Detector : Peak Project : 652049-01 Mode : 19</p>	 <p>Date: 2016-07-25</p> <p>Site : 03CH10-HY Condition : FCC CLASS-B 3m HORN 9120D-HF VERTICAL Detector : Peak Project : 652049-01 Mode : 19</p>

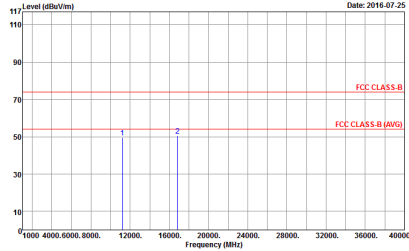
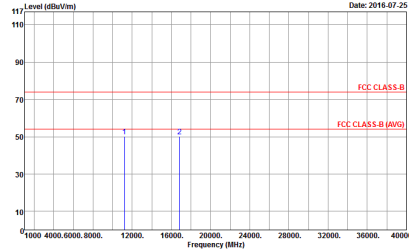

WIFI	Band 3 5470~5725MHz Harmonic @ 3m	
ANT	802.11ac VHT80 CH122 5610MHz	
1+2	Horizontal	Vertical
<p>Peak</p> <p>Avg.</p>	 <p style="font-size: small;">Date: 2016-07-25</p> <p style="font-size: x-small;">Site : 08CH10-HY Condition : FCC CLASS-B 3m HORN 9120D-HF HORIZONTAL Detector : Peak Project : 652049-01 Mode : 20</p>	 <p style="font-size: small;">Date: 2016-07-25</p> <p style="font-size: x-small;">Site : 08CH10-HY Condition : FCC CLASS-B 3m HORN 9120D-HF VERTICAL Detector : Peak Project : 652049-01 Mode : 20</p>



Band 3 - Straddle Channel
WIFI 802.11a (Fundamental @ 3m)

WIFI	Band 3 Straddle Channel Fundamental @ 3m	
ANT	802.11a CH144 5720MHz	
1+2	Horizontal	Vertical
Peak Avg.	<p>Date: 2016-07-25</p> <p>Site : 03CH10-HY Condition : FCC CLASS-B 3m HORN 9120D-HF HORIZONTAL RBW:1000.000KHz VBW:3000.000KHz SWT:Auto Detector : Peak Project : 652049-01 Mode : Z1</p>	<p>Date: 2016-07-25</p> <p>Site : 03CH10-HY Condition : FCC CLASS-B 3m HORN 9120D-HF VERTICAL RBW:1000.000KHz VBW:3000.000KHz SWT:Auto Detector : Peak Project : 652049-01 Mode : Z1</p>

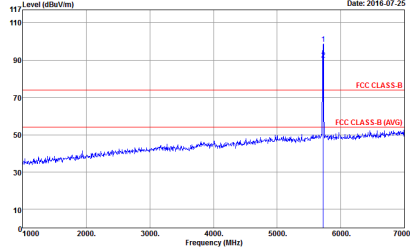
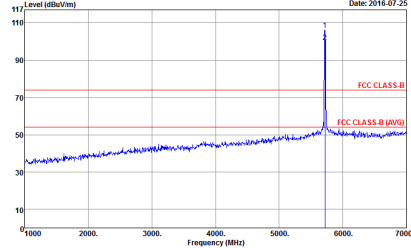

**Band 3 – Straddle Channel
WIFI 802.11ac VHT20 (Fundamental @ 3m)**

WIFI	Band 3 Straddle Channel Fundamental @ 3m	
ANT	802.11ac VHT20 CH144 5720MHz	
1+2	Horizontal	Vertical
<p>Peak</p> <p>Avg.</p>	 <p>Date: 2016-07-25</p> <p>Site : 03CH10-HY Condition : FCC CLASS-B 3m HORN 9120D-HF HORIZONTAL RBW:1000.000KHz VBW:3000.000KHz SWT:Auto Detector : Peak Project : 652049-01 Mode : 22</p>	 <p>Date: 2016-07-25</p> <p>Site : 03CH10-HY Condition : FCC CLASS-B 3m HORN 9120D-HF VERTICAL RBW:1000.000KHz VBW:3000.000KHz SWT:Auto Detector : Peak Project : 652049-01 Mode : 22</p>



**Band 3 – Straddle Channel
WIFI 802.11ac VHT40 (Fundamental @ 3m)**

WIFI	Band 3 Straddle Channel Fundamental @ 3m	
ANT	802.11ac VHT40 CH142 5710MHz	
1+2	Horizontal	Vertical
Peak Avg.	<p>Site : 03CH10-HY Condition : FCC CLASS-B 3m HORN 9120D-HF HORIZONTAL Detector : Peak Project : 652049-01 Mode : 23</p>	<p>Site : 03CH10-HY Condition : FCC CLASS-B 3m HORN 9120D-HF VERTICAL Detector : Peak Project : 652049-01 Mode : 23</p>

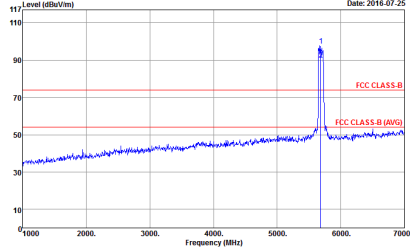
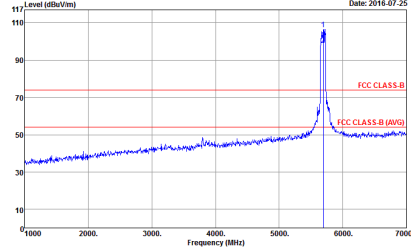

Band 3 – Straddle Channel
WIFI 802.11ac VHT80 (Fundamental @ 3m)

WIFI	Band 3 Straddle Channel Fundamental @ 3m	
ANT	802.11ac VHT80 CH138 5690MHz	
1+2	Horizontal	Vertical
<p>Peak</p> <p>Avg.</p>	 <p>Date: 2016-07-25</p> <p>Site : 03CH10-HY Condition : FCC CLASS-B 3m HORN 9120D-HF HORIZONTAL RBW:1000.000KHz VBW:3000.000KHz SWT:Auto Detector : Peak Project : 652049-01 Mode : 24</p>	 <p>Date: 2016-07-25</p> <p>Site : 03CH10-HY Condition : FCC CLASS-B 3m HORN 9120D-HF VERTICAL RBW:1000.000KHz VBW:3000.000KHz SWT:Auto Detector : Peak Project : 652049-01 Mode : 24</p>



Band 3 - Straddle Channel
WIFI 802.11a (Harmonic @ 3m)

WIFI	Band 3 Straddle Channel Harmonic @ 3m	
ANT	802.11a CH144 5720MHZ	
1+2	Horizontal	Vertical
Peak Avg.	<p>Site : 03CH10-HY Condition : FCC CLASS-B 3m HORN 9120D-HF HORIZONTAL Detector : Peak Project : 652049 Mode : 21</p>	<p>Site : 03CH10-HY Condition : FCC CLASS-B 3m HORN 9120D-HF VERTICAL Detector : Peak Project : 652049 Mode : 21</p>

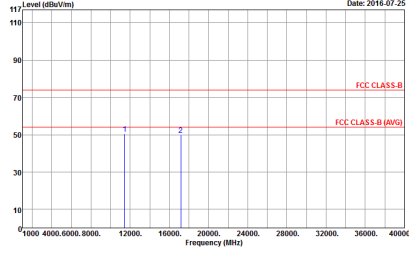
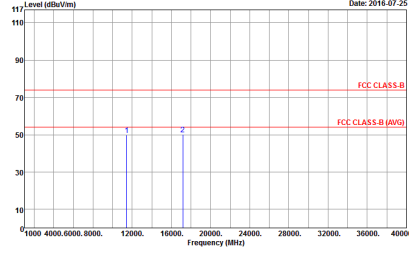

Band 3 – Straddle Channel
WIFI 802.11ac VHT20 (Harmonic @ 3m)

WIFI	Band 3 Straddle Channel Harmonic @ 3m	
ANT	802.11ac VHT20 CH144 5720MHz	
1+2	Horizontal	Vertical
<p>Peak</p> <p>Avg.</p>	 <p>Site : 03CH10-HY Condition : FCC CLASS-B 3m HORN 9120D-HF HORIZONTAL Detector : Peak Project : 652049 Mode : 22</p>	 <p>Site : 03CH10-HY Condition : FCC CLASS-B 3m HORN 9120D-HF VERTICAL Detector : Peak Project : 652049 Mode : 22</p>

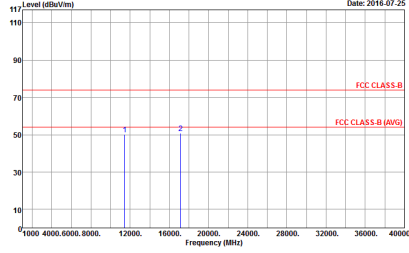
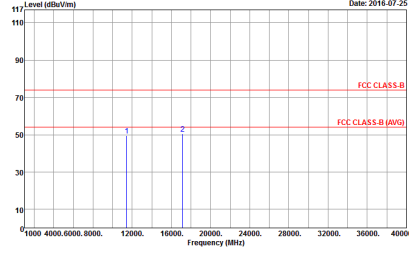

**Band 3 – Straddle Channel
WIFI 802.11ac VHT40 (Harmonic @ 3m)**

WIFI	Band 3 Straddle Channel Harmonic @ 3m	
ANT	802.11ac VHT40 CH142 5710MHz	
1+2	Horizontal	Vertical
<p>Peak</p> <p>Avg.</p>	 <p>Date: 2016-07-25</p> <p>Site : 03CH10-HY Condition : FCC CLASS-B 3m HORN 9120D-HF HORIZONTAL Detector : Peak Project : 652049 Mode : 23</p>	 <p>Date: 2016-07-25</p> <p>Site : 03CH10-HY Condition : FCC CLASS-B 3m HORN 9120D-HF VERTICAL Detector : Peak Project : 652049 Mode : 23</p>

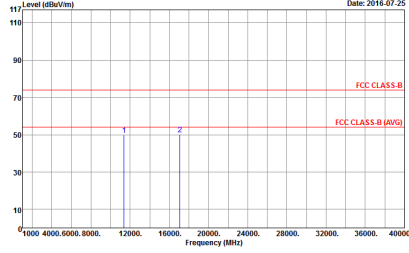
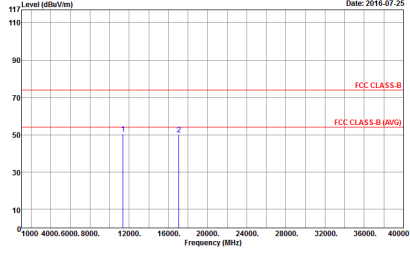

**Band 3 – Straddle Channel
WIFI 802.11ac VHT80 (Harmonic @ 3m)**

WIFI	Band 3 Straddle Channel Harmonic @ 3m	
ANT	802.11ac VHT80 CH138 5690MHz	
1+2	Horizontal	Vertical
<p>Peak</p> <p>Avg.</p>	 <p>Site : 03CH10-HY Condition : FCC CLASS-B 3m HORN 9120D-HF HORIZONTAL Detector : Peak Project : 652049 Mode : 24</p>	 <p>Site : 03CH10-HY Condition : FCC CLASS-B 3m HORN 9120D-HF VERTICAL Detector : Peak Project : 652049 Mode : 24</p>



**Emission below 1GHz
5GHz WIFI 802.11a (LF)**

WIFI	5GHz WIFI	
ANT	802.11a LF	
1+2	Horizontal	Vertical
QP / Peak	<p> Site : 03CH10-HY Condition : FCC CLASS-B 3m BT-LOG 6111D-LF HORIZONTAL Detector : Peak Project : 652049 Mode : 25 </p>	<p> Site : 03CH10-HY Condition : FCC CLASS-B 3m BT-LOG 6111D-LF VERTICAL Detector : Peak Project : 652049 Mode : 25 </p>



Emission below 1GHz
5GHz WIFI 802.11ac VHT20 (LF)

Table with 2 columns: Horizontal and Vertical. Each column contains a graph of Level (dBuV/m) vs Frequency (MHz) from 50 to 1000 MHz. The graphs show a blue signal line and a red horizontal limit line labeled 'FCC CLASS B'. The signal levels are consistently below the limit line.

Note: Measured Quasi-Peak level does not exceed the limit line.



Emission below 1GHz
5GHz WIFI 802.11ac VHT40 (LF)

Table with 2 columns: Horizontal and Vertical. Each column contains a graph of Level (dBuV/m) vs Frequency (MHz) from 50 to 1000 MHz. The graphs show a blue signal line and a red FCC CLASS B limit line. The signal level is consistently below the limit line.

Note: Measured Quasi-Peak level does not exceed the limit line.



Emission below 1GHz
5GHz WIFI 802.11ac VHT80 (LF)

WIFI	5GHz WIFI	
ANT	802.11ac VHT80 LF	
1+2	Horizontal	Vertical
QP / Peak	<p>Site : 03CH10-HY Condition : FCC CLASS-B 3m BT-LOG 6111D-LF HORIZONTAL Detector : Peak Project : 652049 Mode : 27</p>	<p>Site : 03CH10-HY Condition : FCC CLASS-B 3m BT-LOG 6111D-LF VERTICAL Detector : Peak Project : 652049 Mode : 27</p>

Note: Measured Quasi-Peak level does not exceed the limit line.



Appendix D. Duty Cycle Plots

<CDD Modes>

Antenna		Duty Cycle(%)	T(us)	1/T(kHz)	VBW Setting
1+2+3+4	802.11a ANT 1	96.27	2064	0.484	1kHz
1+2+3+4	802.11a ANT 2	96.27	2064	0.484	1kHz
1+2+3+4	802.11a ANT 3	96.27	2064	0.484	1kHz
1+2+3+4	802.11a ANT 4	96.24	2048	0.488	1kHz



802.11a

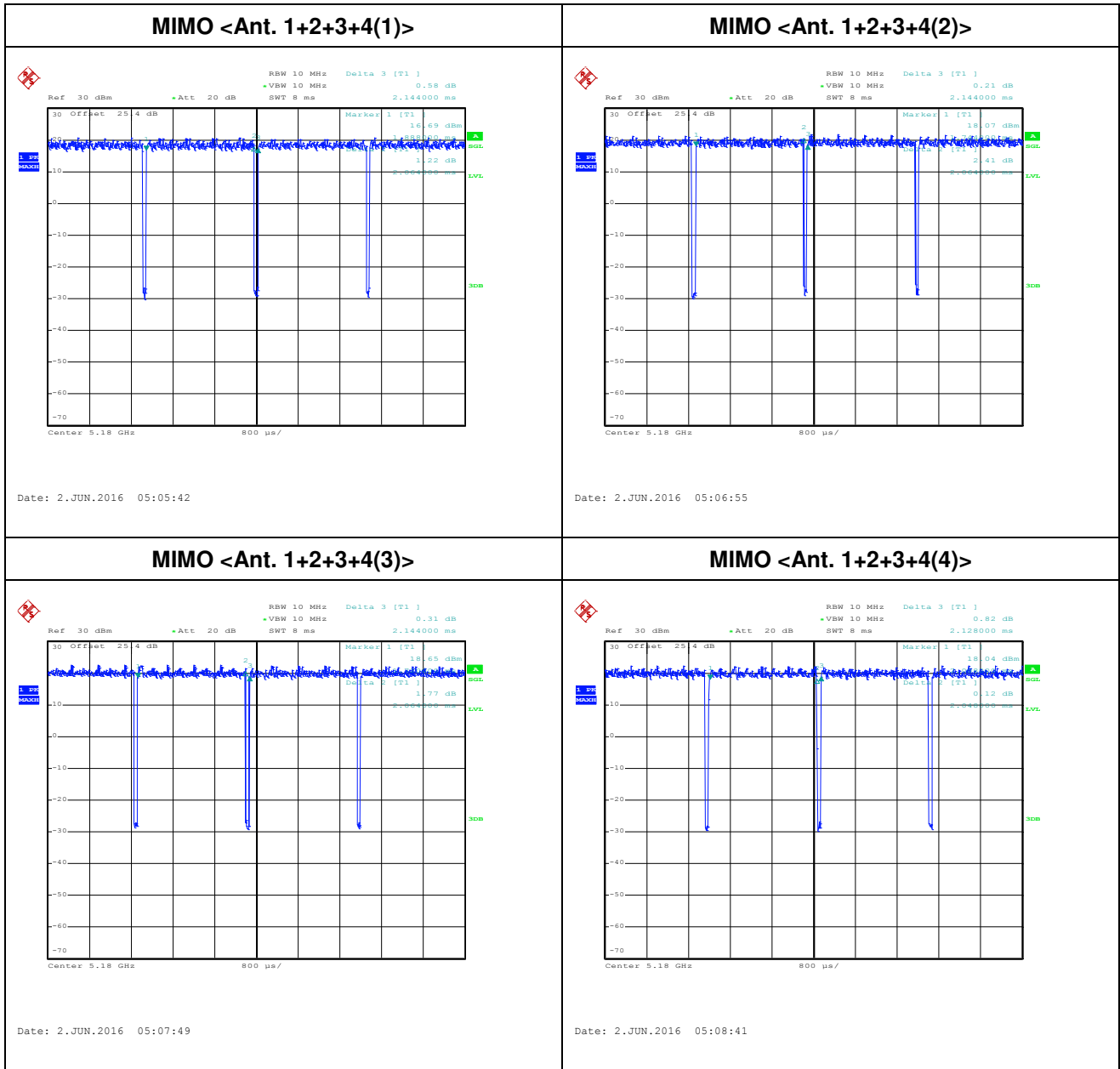

<TXBF Modes>

Antenna		Duty Cycle(%)	T(us)	1/T(kHz)	VBW Setting
1+2+3+4	802.11ac VHT20 ANT 1	98.58*	5016	0.194	1kHz
1+2+3+4	802.11ac VHT20 ANT 2	98.58*	5016	0.194	1kHz
1+2+3+4	802.11ac VHT20 ANT 3	98.58*	5016	0.194	1kHz
1+2+3+4	802.11ac VHT20 ANT 4	98.58*	5016	0.194	1kHz

Antenna		Duty Cycle(%)	T(us)	1/T(kHz)	VBW Setting
1+2+3+4	802.11ac VHT40 ANT 1	96.82*	2432	0.411	1kHz
1+2+3+4	802.11ac VHT40 ANT 2	97.45*	2448	0.408	1kHz
1+2+3+4	802.11ac VHT40 ANT 3	96.82*	2432	0.411	1kHz
1+2+3+4	802.11ac VHT40 ANT 4	97.45*	2448	0.408	1kHz

Antenna		Duty Cycle(%)	T(us)	1/T(kHz)	VBW Setting
1+2+3+4	802.11ac VHT80 ANT 1	94.31*	1160	0.862	1kHz
1+2+3+4	802.11ac VHT80 ANT 2	93.44*	1140	0.877	1kHz
1+2+3+4	802.11ac VHT80 ANT 3	93.50*	1150	0.869	1kHz
1+2+3+4	802.11ac VHT80 ANT 4	92.74*	1150	0.869	1kHz

Note *: Duty cycle is not a constant value during the continuous beamforming transmission.



802.11ac VHT20

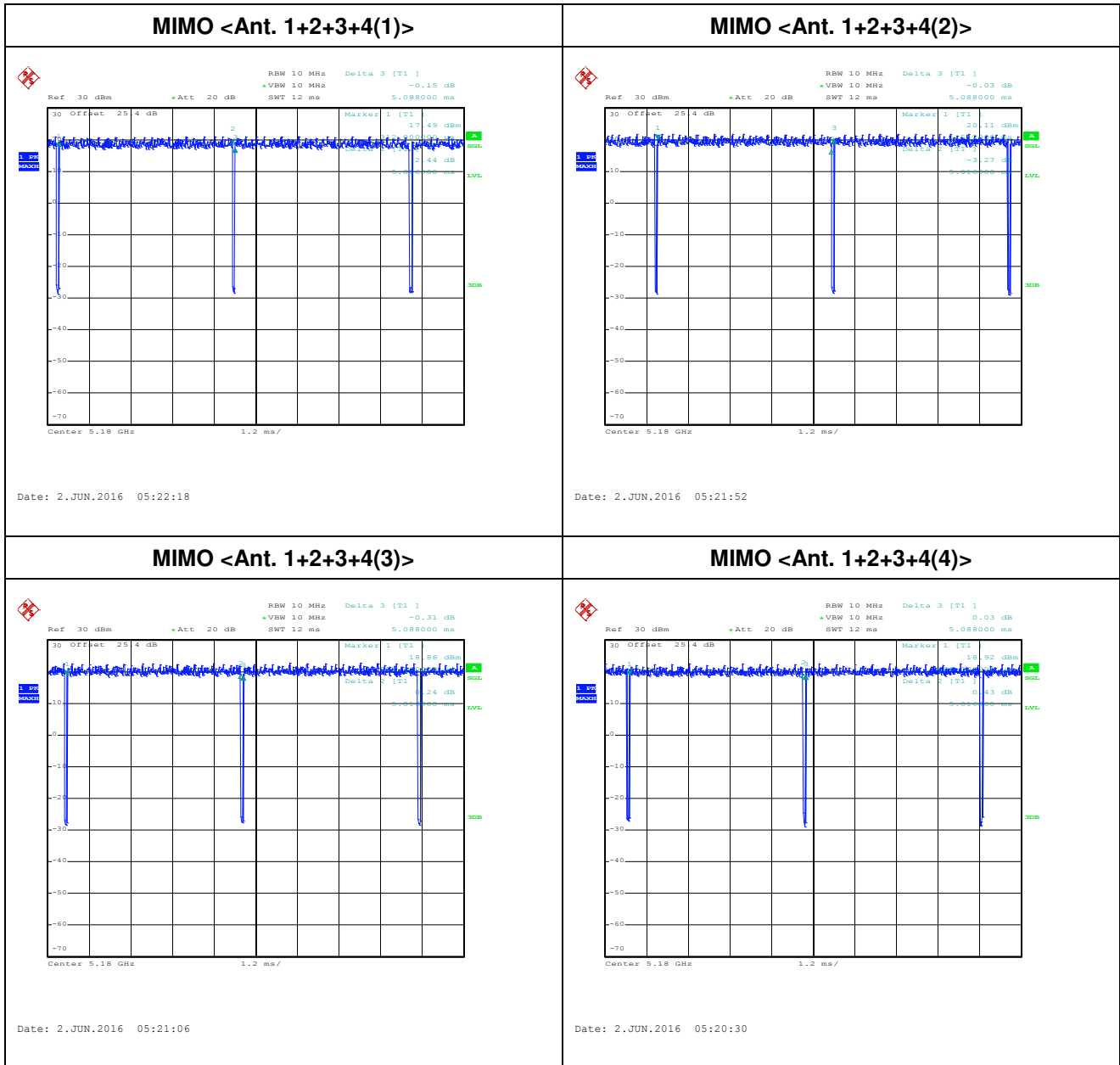



802.11ac VHT40

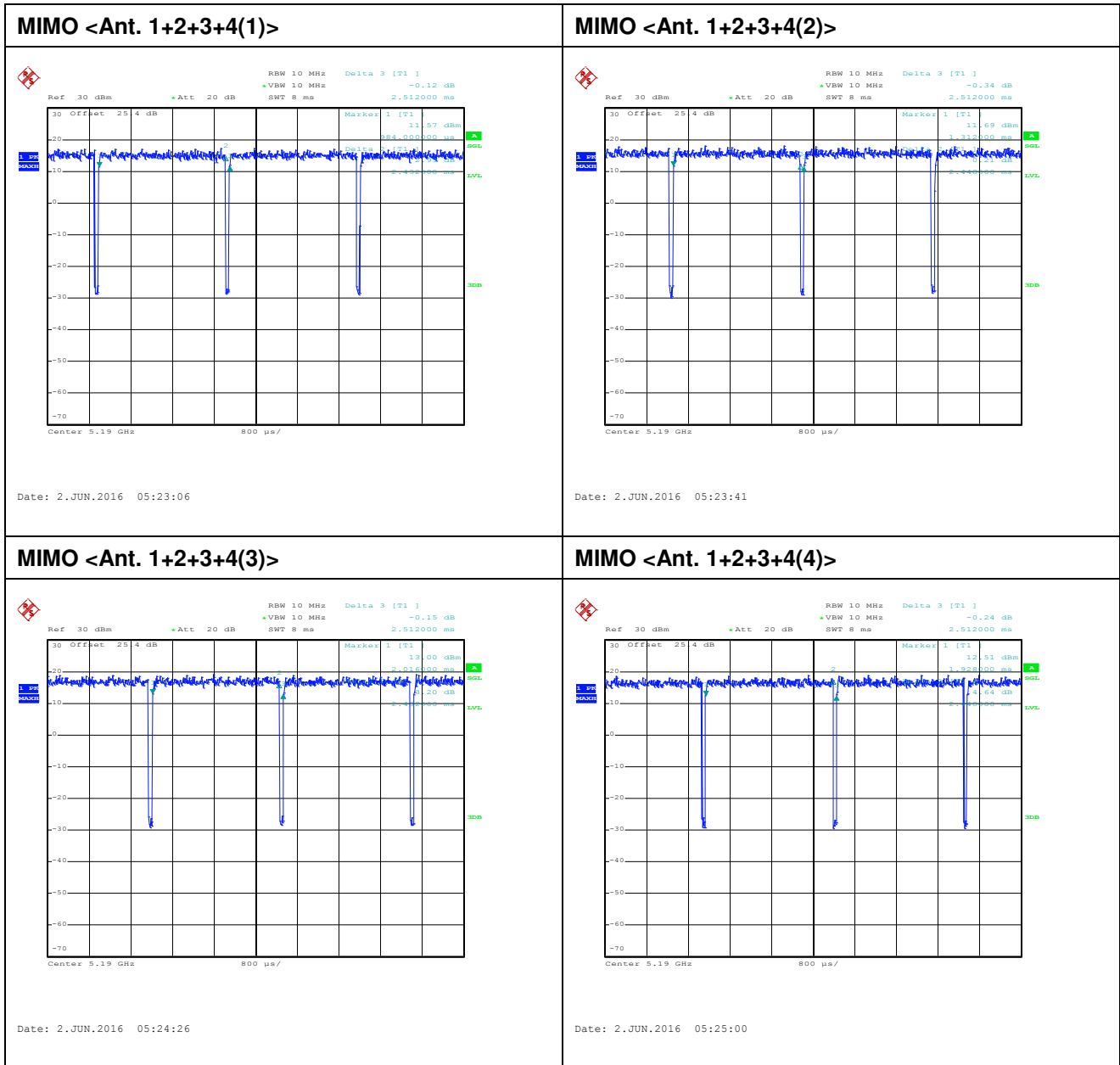



802.11ac VHT80

