



FCC RF Test Report

APPLICANT : Ignition Design Labs (US) LLC
EQUIPMENT : Advanced Wireless Router
BRAND NAME : Ignition Design Labs
MODEL NAME : Portal
MARKETING NAME : Portal
FCC ID : 2AFZUSAP102
STANDARD : FCC Part 15 Subpart C §15.247
CLASSIFICATION : (DTS) Digital Transmission System

The product was received on May 20, 2016 and testing was completed on Jul. 13, 2016. We, SPORTON INTERNATIONAL INC., would like to declare that the tested sample has been evaluated in accordance with the test procedures and has been in compliance with the applicable technical standards.

The test results in this report apply exclusively to the tested model / sample. Without written approval of SPORTON INTERNATIONAL INC., the test report shall not be reproduced except in full.

Reviewed by: Joseph Lin / Supervisor

Approved by: Jones Tsai / Manager



SPORTON INTERNATIONAL INC.

No. 52, Hwa Ya 1st Rd., Hwa Ya Technology Park, Kwei-Shan District, Tao Yuan City, Taiwan, R.O.C.



TABLE OF CONTENTS

REVISION HISTORY 3

SUMMARY OF TEST RESULT 4

1 GENERAL DESCRIPTION 5

 1.1 Applicant 5

 1.2 Manufacturer 5

 1.3 Product Feature of Equipment Under Test 5

 1.4 Product Specification of Equipment Under Test 6

 1.5 Modification of EUT 6

 1.6 Testing Location 7

 1.7 Applicable Standards 8

2 TEST CONFIGURATION OF EQUIPMENT UNDER TEST 9

 2.1 Carrier Frequency and Channel 9

 2.2 Test Mode 10

 2.3 Connection Diagram of Test System 11

 2.4 Support Unit used in test configuration and system 12

 2.5 EUT Operation Test Setup 12

 2.6 Measurement Results Explanation Example 12

3 TEST RESULT 13

 3.1 6dB and 99% Bandwidth Measurement 13

 3.2 Average Output Power Measurement 15

 3.3 Power Spectral Density Measurement 16

 3.4 Conducted Band Edges and Spurious Emission Measurement 18

 3.5 Radiated Band Edges and Spurious Emission Measurement 55

 3.6 AC Conducted Emission Measurement 59

 3.7 Antenna Requirements 63

4 LIST OF MEASURING EQUIPMENT 65

5 UNCERTAINTY OF EVALUATION 66

APPENDIX A. CONDUCTED TEST RESULTS

APPENDIX B. RADIATED SPURIOUS EMISSION

APPENDIX C. RADIATED SPURIOUS EMISSION PLOTS

APPENDIX D. DUTY CYCLE PLOTS

APPENDIX E. SETUP PHOTOGRAPHS



REVISION HISTORY

REPORT NO.	VERSION	DESCRIPTION	ISSUED DATE
FR652049F	Rev. 01	Initial issue of report	Jul. 14, 2016



SUMMARY OF TEST RESULT

Report Section	FCC Rule	Description	Limit	Result	Remark
3.1	15.247(a)(2)	6dB Bandwidth	$\geq 0.5\text{MHz}$	Pass	-
3.1	-	99% Bandwidth	-	Pass	-
3.2	15.247(b)	Power Output Measurement	$\leq 30\text{dBm}$	Pass	-
3.3	15.247(e)	Power Spectral Density	$\leq 8\text{dBm}/3\text{kHz}$	Pass	-
3.4	15.247(d)	Conducted Band Edges	$\leq 30\text{dBc}$	Pass	-
		Conducted Spurious Emission		Pass	-
3.5	15.247(d)	Radiated Band Edges and Radiated Spurious Emission	15.209(a) & 15.247(d)	Pass	Under limit 0.11 dB at 2390.000 MHz
3.6	15.207	AC Conducted Emission	15.207(a)	Pass	Under limit 4.70 dB at 0.550 MHz
3.7	15.203 & 15.247(b)	Antenna Requirement	N/A	Pass	-



1 General Description

1.1 Applicant

Ignition Design Labs (US) LLC

5F-2., No.158, Sec.2, Gongdao 5th Rd., Hsinchu City 30070, Taiwan

1.2 Manufacturer

Ignition Design Labs (US) LLC

5F-2., No.158, Sec.2, Gongdao 5th Rd., Hsinchu City 30070, Taiwan

1.3 Product Feature of Equipment Under Test

Product Feature	
Equipment	Advanced Wireless Router
Brand Name	Ignition Design Labs
Model Name	Portal
Marketing Name	Portal
FCC ID	2AFZUSAP102
EUT supports Radios application	WLAN 11a/b/g/n HT20/HT40 WLAN 11ac VHT20/VHT40/VHT80 Bluetooth v4.1 EDR/LE
HW Version	v1.0
SW Version	v1.0
EUT Stage	Identical Prototype

Remark: The above EUT's information was declared by manufacturer. Please refer to the specifications or user's manual for more detailed description.



1.4 Product Specification of Equipment Under Test

Standards-related Product Specification									
Tx/Rx Channel Frequency Range	802.11b/g/n : 2412 MHz ~ 2462 MHz								
Maximum (Average) Output Power to antenna	<MIMO Ant. 1+2+3> 802.11b : 28.48 dBm (0.7047 W) 802.11g : 21.75 dBm (0.1496 W) 802.11n HT20 : 20.52 dBm (0.1127 W) 802.11n HT40 : 21.08 dBm (0.1282 W)								
99% Occupied Bandwidth	802.11b : 11.80MHz 802.11g : 16.80MHz 802.11n HT20 : 17.80MHz 802.11n HT40 : 36.10MHz								
Type of Modulation	802.11b : DSSS (DBPSK / DQPSK / CCK) 802.11g/n : OFDM (BPSK / QPSK / 16QAM / 64QAM)								
Antenna Type	PCB Antenna								
Antenna Gain	Antenna 1: 3.50 dBi Antenna 2: 3.74 dBi Antenna 3: 3.39 dBi								
Antenna Function for Transmitter	<table border="1"> <thead> <tr> <th></th> <th>Ant. 1</th> <th>Ant. 2</th> <th>Ant. 3</th> </tr> </thead> <tbody> <tr> <td>802.11 b/g/n MIMO</td> <td>V</td> <td>V</td> <td>V</td> </tr> </tbody> </table>		Ant. 1	Ant. 2	Ant. 3	802.11 b/g/n MIMO	V	V	V
	Ant. 1	Ant. 2	Ant. 3						
802.11 b/g/n MIMO	V	V	V						

1.5 Modification of EUT

No modifications are made to the EUT during all test items.



1.6 Testing Location

Sporton Lab is accredited to ISO 17025 by Taiwan Accreditation Foundation (TAF code : 1190) and the FCC designation No. TW1022 under the FCC 2.948(e) by Mutual Recognition Agreement (MRA) in FCC Test.

Test Site	SPORTON INTERNATIONAL INC.	
Test Site Location	No. 52, Hwa Ya 1 st Rd., Hwa Ya Technology Park, Kwei-Shan District, Tao Yuan City, Taiwan, R.O.C. TEL: +886-3-327-3456 FAX: +886-3-328-4978	
Test Site No.	Sporton Site No.	
	TH02-HY	CO05-HY

Note: The test site complies with ANSI C63.4 2014 requirement.

Test Site	SPORTON INTERNATIONAL INC.	
Test Site Location	No.58, Aly. 75, Ln. 564, Wenhua 3rd Rd. Guishan Dist, Taoyuan City, Taiwan (R.O.C.) TEL: +886-3-327-0868 FAX: +886-3-327-0855	
Test Site No.	Sporton Site No.	
	03CH10-HY	

Note: The test site complies with ANSI C63.4 2014 requirement.



1.7 Applicable Standards

According to the specifications of the manufacturer, the EUT must comply with the requirements of the following standards:

- ♦ FCC Part 15 Subpart C §15.247
- ♦ FCC KDB Publication No. 558074 D01 DTS Meas. Guidance v03r05
- ♦ FCC KDB 662911 D01 Multiple Transmitter Output v02r01.
- ♦ ANSI C63.10-2013

Remark:

1. All test items were verified and recorded according to the standards and without any deviation during the test.
2. This EUT has also been tested and complied with the requirements of FCC Part 15, Subpart B, recorded in a separate test report.



2 Test Configuration of Equipment Under Test

The EUT has been associated with peripherals and configuration operated in a manner tended to maximize its emission characteristics in a typical application. Frequency range investigated: conducted emission (150 kHz to 30 MHz) and radiated emission (9 kHz to the 10th harmonic of the highest fundamental frequency or to 40 GHz, whichever is lower). For radiated measurement, pre-scanned in three orthogonal panels, X, Y, Z. The worst cases (X plane) were recorded in this report.

Based on the worst configuration found above, the RF power setting is set individually to meet FCC compliance limit for the final conducted and radiated tests shown in section 2.2.

2.1 Carrier Frequency and Channel

Frequency Band	Channel	Freq. (MHz)	Channel	Freq. (MHz)
2400-2483.5 MHz	1	2412	7	2442
	2	2417	8	2447
	3	2422	9	2452
	4	2427	10	2457
	5	2432	11	2462
	6	2437		



2.2 Test Mode

Final test mode of conducted test items and radiated spurious emissions are considering the modulation and worse data rates as below table.

MIMO Antenna

<2.4GHz>

Modulation	Data Rate
802.11b	1 Mbps
802.11g	6 Mbps
802.11n HT20	MCS0
802.11n HT40	MCS0

Test Cases	
AC Conducted Emission	Mode 1 : WLAN (2.4GHz) Link 802.11n HT20 MCS0 + Bluetooth Link + WAN Link + LAN Link + USB Link + Adapter 1

2.3 Connection Diagram of Test System

<WLAN Tx Mode>

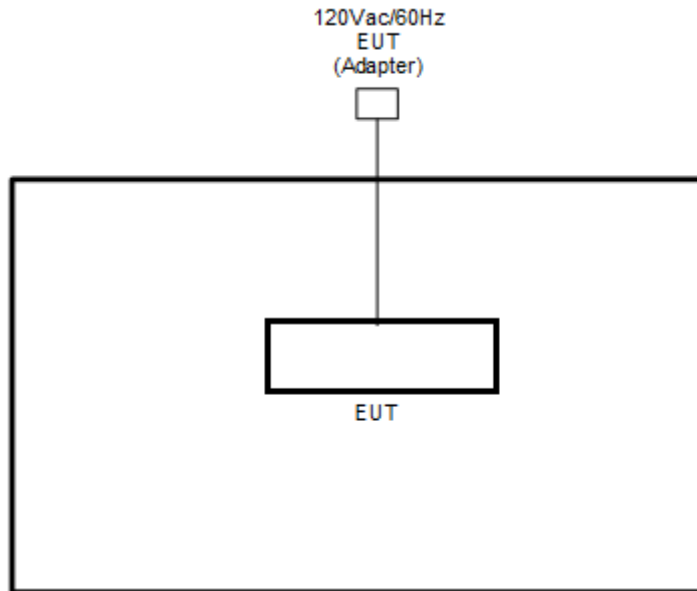

<AC Conducted Emission Mode>

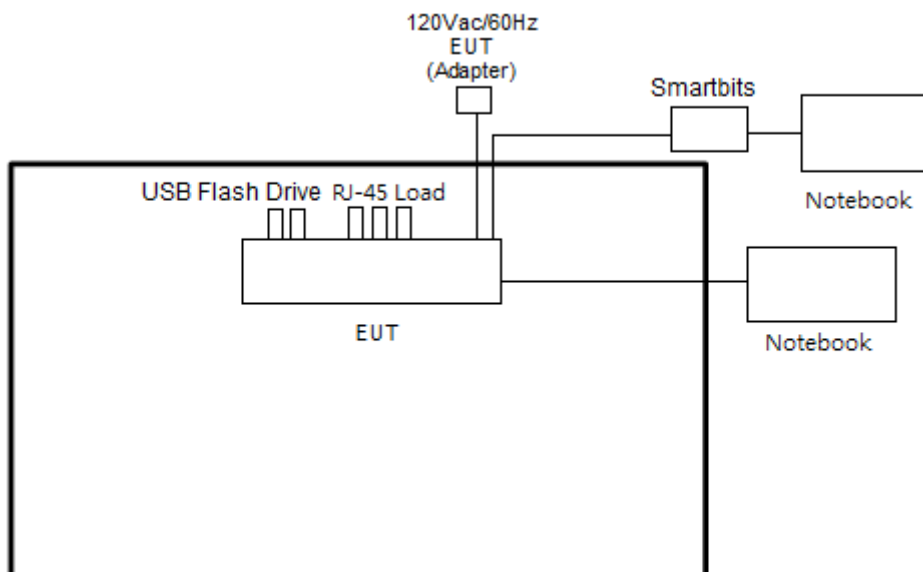



2.4 Support Unit used in test configuration and system

Item	Equipment	Trade Name	Model Name	FCC ID	Data Cable	Power Cord
1.	Notebook	DELL	P20G	FCC DoC	N/A	AC I/P: Unshielded, 1.2 m DC O/P: Shielded, 1.8 m
2.	Notebook	DELL	Latitude E6320	FCC DoC/ Contains FCC ID: QDS-BRCM1054	N/A	AC I/P: Unshielded, 1.2 m DC O/P: Shielded, 1.8 m
3.	USB Flash Drive	Transcend	JetFlash 700	FCC DoC	N/A	N/A
4.	Smartbits	Spirent	SMB600B	N/A	Shielded, 1.5m	Unshielded, 1.5m

2.5 EUT Operation Test Setup

For WLAN function, programmed RF utility, "QRCT" installed in the notebook and command lines make the EUT provide functions like channel selection and power level for continuous transmitting and receiving signals.

2.6 Measurement Results Explanation Example

For all conducted test items:

The offset level is set in the spectrum analyzer to compensate the RF cable loss and attenuator factor between EUT conducted output port and spectrum analyzer. With the offset compensation, the spectrum analyzer reading level is exactly the EUT RF output level.

Example:

The spectrum analyzer offset is derived from RF cable loss and attenuator factor.

Offset = RF cable loss + attenuator factor.

Following shows an offset computation example with cable loss 4.2 dB and 10dB attenuator.

$$\begin{aligned}
 \text{Offset(dB)} &= \text{RF cable loss(dB)} + \text{attenuator factor(dB)}. \\
 &= 4.2 + 10 = 14.2 \text{ (dB)}
 \end{aligned}$$

3 Test Result

3.1 6dB and 99% Bandwidth Measurement

3.1.1 Limit of 6dB and 99% Bandwidth

The minimum 6 dB bandwidth shall be at least 500 kHz.

3.1.2 Measuring Instruments

The measuring equipment is listed in the section 4 of this test report.

3.1.3 Test Procedures

1. The testing follows FCC KDB Publication No. 558074 DTS D01 Meas. Guidance v03r05.
2. The RF output of EUT was connected to the spectrum analyzer by RF cable and attenuator. The path loss was compensated to the results for each measurement.
3. Set to the maximum power setting and enable the EUT transmit continuously.
4. Make the measurement with the spectrum analyzer's resolution bandwidth (RBW) = 100 kHz. Set the Video bandwidth (VBW) = 300 kHz. In order to make an accurate measurement. The 6 dB bandwidth must be greater than 500 kHz.
5. For 99% Bandwidth Measurement, the spectrum analyzer's resolution bandwidth (RBW) = 1MHz and set the Video bandwidth (VBW) = 3MHz.
6. Measure and record the results in the test report.

3.1.4 Test Setup

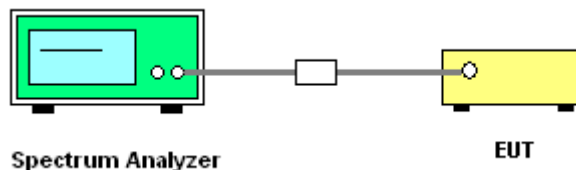



3.1.5 Test Result of 6dB and 99% Occupied Bandwidth

Please refer to Appendix A.

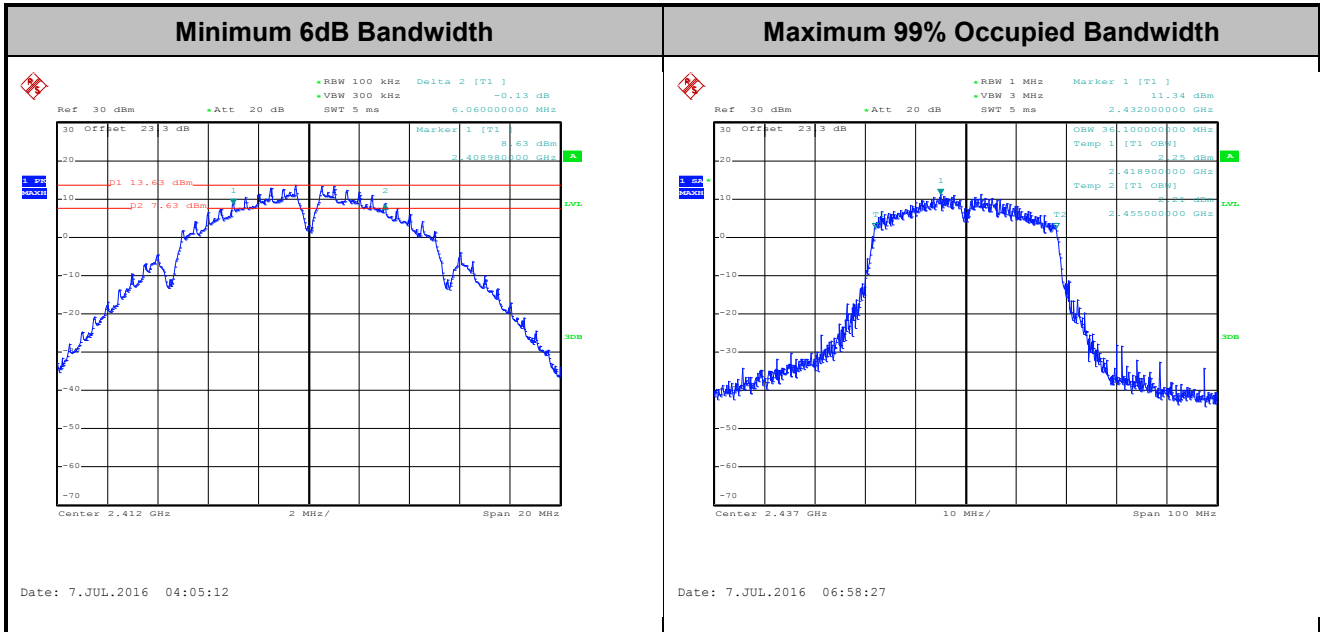

Note : The occupied channel bandwidth is maintained within the band of operation for all of the modulations.

3.2 Average Output Power Measurement

3.2.1 Limit of Average Output Power

For systems using digital modulation in the 2400-2483.5MHz, the limit for average output power is 30dBm. If transmitting antenna with directional gain greater than 6dBi is used, the average output power from the intentional radiator shall be reduced below the above stated value by the amount in dB that the directional gain of the antenna exceeds 6 dBi. In case of point-to-point operation, the limit has to be reduced by 1dB for every 3dB that the directional gain of the antenna exceeds 6dBi.

3.2.2 Measuring Instruments

The measuring equipment is listed in the section 4 of this test report.

3.2.3 Test Procedures

1. The testing follows the Measurement Procedure of FCC KDB No. 558074 DTS D01 Meas. Guidance v03r05 section 9.2.3.1 Method AVGPM
2. The RF output of EUT was connected to the power meter by RF cable and attenuator. The path loss was compensated to the results for each measurement.
3. Set to the maximum power setting and enable the EUT transmit continuously.
4. Measure the conducted output power and record the results in the test report.
5. For MIMO mode, calculation method follows FCC KDB 662911 D01 Multiple Transmitter Output v02r01.

3.2.4 Test Setup

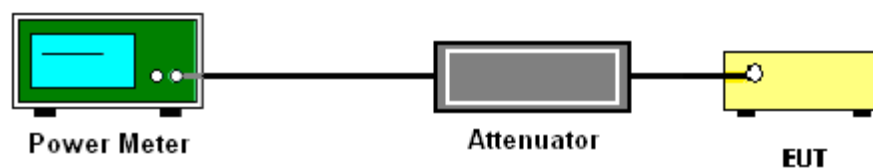

3.2.5 Test Result of Peak Output Power

Please refer to Appendix A of this test report.

3.2.6 Test Result of Average output Power

Please refer to Appendix A



3.3 Power Spectral Density Measurement

3.3.1 Limit of Power Spectral Density

The peak power spectral density shall not be greater than 8dBm in any 3kHz band at any time interval of continuous transmission.

3.3.2 Measuring Instruments

The measuring equipment is listed in the section 4 of this test report.

3.3.3 Test Procedures

1. The testing follows Measurement Procedure 10.5 Method AVGPSD-2 of FCC KDB Publication No. 558074 D01 DTS Meas. Guidance v03r05.
2. The RF output of EUT was connected to the spectrum analyzer by RF cable and attenuator. The path loss was compensated to the results for each measurement.
3. Set to the maximum power setting and enable the EUT transmit continuously.
4. Make the measurement with the spectrum analyzer's resolution bandwidth (RBW) = 10 kHz. Video bandwidth VBW = 30 kHz In order to make an accurate measurement, set the span to 1.5 times DTS Channel Bandwidth. (6dB BW).
5. Number of points in sweep ≥ 2 Span / RBW. (This ensures that bin-to-bin spacing is \leq RBW/2, so that narrowband signals are not lost between frequency bins).
6. Detector = RMS, Sweep time = auto couple.
7. Trace average at least 100 traces in power averaging mode.
8. Add $10 \log(1/x)$, where x is the duty cycle, to the measured power in order to compute the average power during the actual transmission times. For example, add $10 \log(1/0.25) = 6$ dB if the duty cycle is 25 percent.
9. Measure and record the results in the test report. For MIMO mode, calculation method follows FCC KDB 662911 D01 Multiple Transmitter Output v02r01.
Method (c): Measure and add $10 \log(N_{ANT})$ dB.

With this technique, spectrum measurements are performed at each output of the device, but rather than summing the spectra or the spectral peaks across the outputs, the quantity $10 \log(N_{ANT})$ dB is added to each spectrum value before comparing to the emission limit. The addition of $10 \log(N_{ANT})$ dB serves to apportion the emission limit among the N_{ANT} outputs so that each output is permitted to contribute no more than $1/N_{ANT}^{th}$ of the PSD limit .

3.3.4 Test Setup

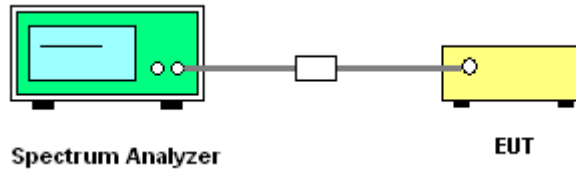

3.3.5 Test Result of Power Spectral Density

Please refer to Appendix A.

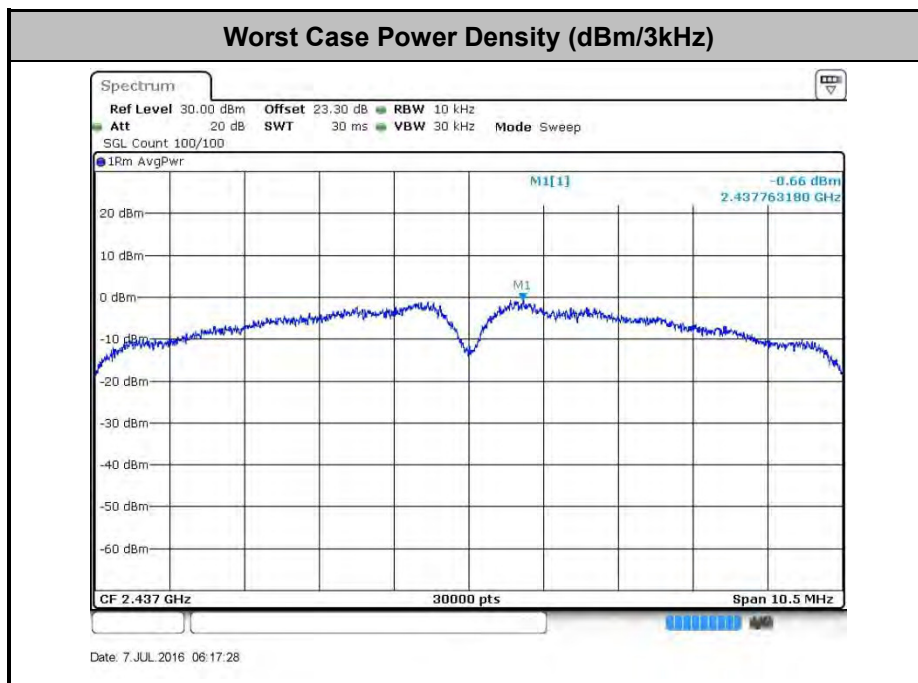

3.4 Conducted Band Edges and Spurious Emission Measurement

3.4.1 Limit of Conducted Band Edges and Spurious Emission Measurement

In any 100 kHz bandwidth outside of the authorized frequency band, the emissions which fall in the non-restricted bands shall be attenuated at least 20 dB / 30dB relative to the maximum PSD level in 100 kHz by RF conducted measurement and radiated emissions which fall in the restricted bands, as defined in Section 15.205(a), must also comply with the radiated emission limits specified in Section 15.209(a).

3.4.2 Measuring Instruments

The measuring equipment is listed in the section 4 of this test report.

3.4.3 Test Procedures

1. The testing follows FCC KDB Publication No. 558074 D01 DTS Meas. Guidance v03r05.
2. The RF output of EUT was connected to the spectrum analyzer by RF cable and attenuator. The path loss was compensated to the results for each measurement.
3. Set to the maximum power setting and enable the EUT transmit continuously.
4. Set RBW = 100 kHz, VBW=300 kHz, Peak Detector. Unwanted Emissions measured in any 100 kHz bandwidth outside of the authorized frequency band shall be attenuated by at least 20 dB relative to the maximum in-band peak PSD level in 100 kHz when maximum peak conducted output power procedure is used. If the transmitter complies with the conducted power limits based on the use of RMS averaging over a time interval, the attenuation required under this paragraph shall be 30 dB instead of 20 dB per 15.247(d).
5. Measure and record the results in the test report.
6. The RF fundamental frequency should be excluded against the limit line in the operating frequency band.

3.4.4 Test Setup

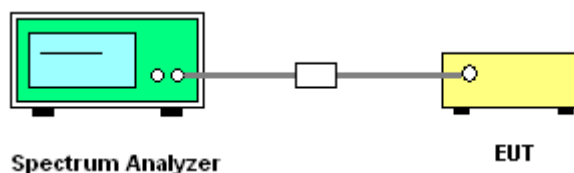



3.4.5 Test Result of Conducted Band Edges and Spurious Emission

Number of TX = 3, Ant. 1 (Measured)

Number of TX	3	Ant. :	1
Test Mode :	802.11b	Temperature :	21~25°C
Test Band :	2.4GHz Low	Relative Humidity :	51~54%
Test Channel :	01	Test Engineer :	Derek Hsu

WLAN 802.11b Channel 01

100kHz PSD reference Level

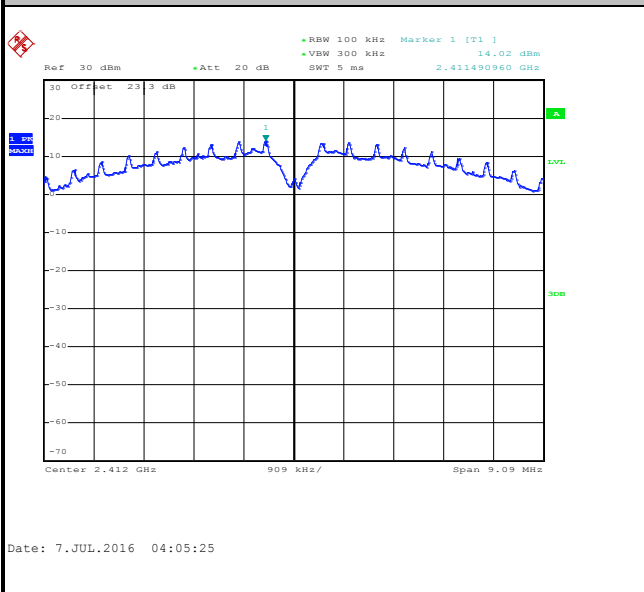

Low Channel Plot

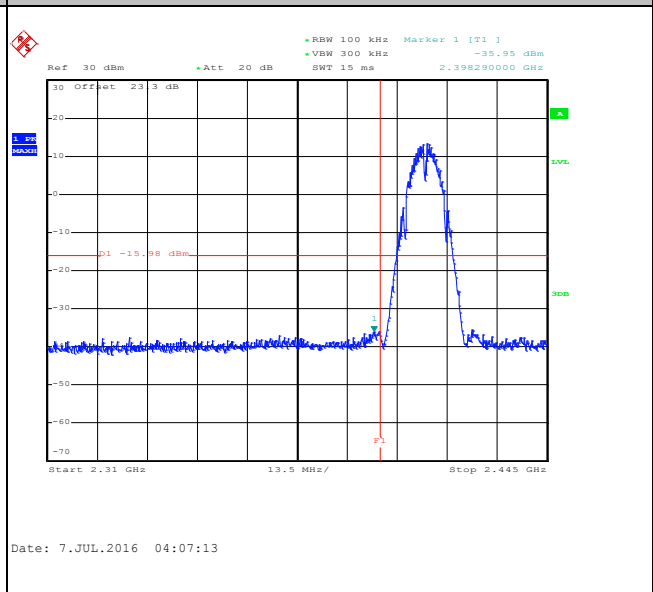

Spurious Emission 30MHz~3GHz

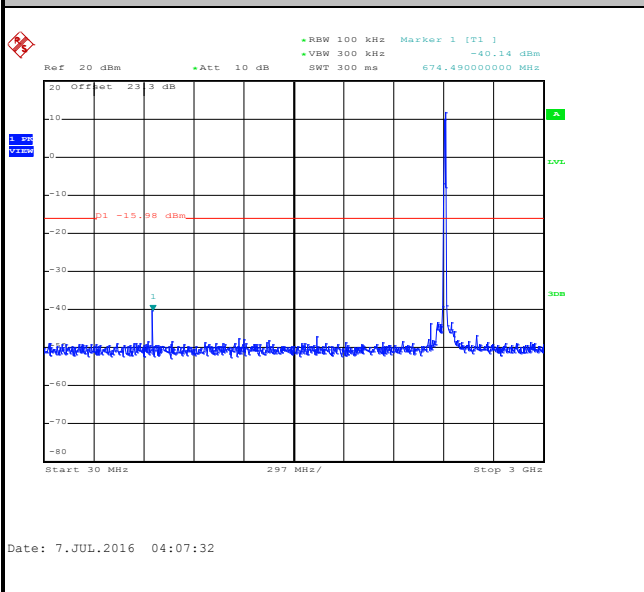

Spurious Emission 2GHz~25GHz

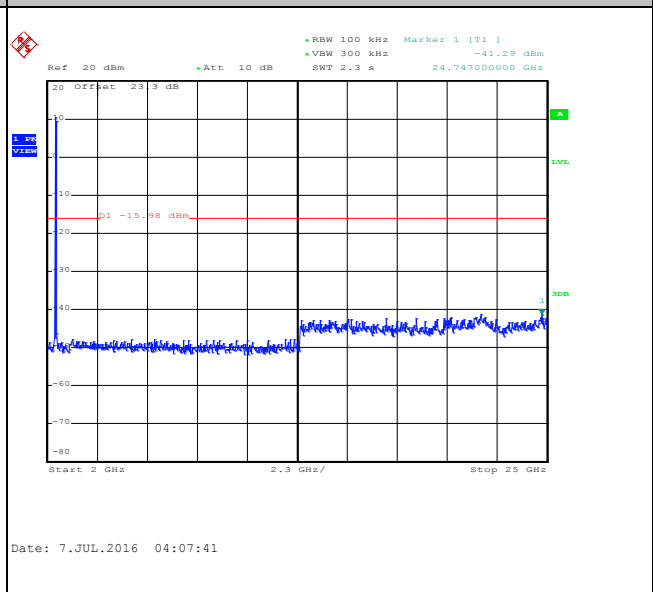



Number of TX :	3	Ant. :	1
Test Mode :	802.11b	Temperature :	21~25°C
Test Band :	2.4GHz Mid	Relative Humidity :	51~54%
Test Channel :	06	Test Engineer :	Derek Hsu

WLAN 802.11b Channel 06

100kHz PSD reference Level

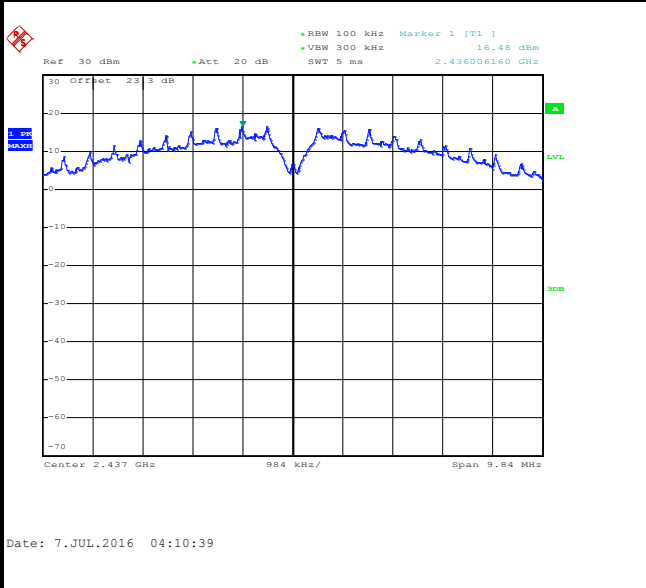

Spurious Emission 30MHz~3GHz

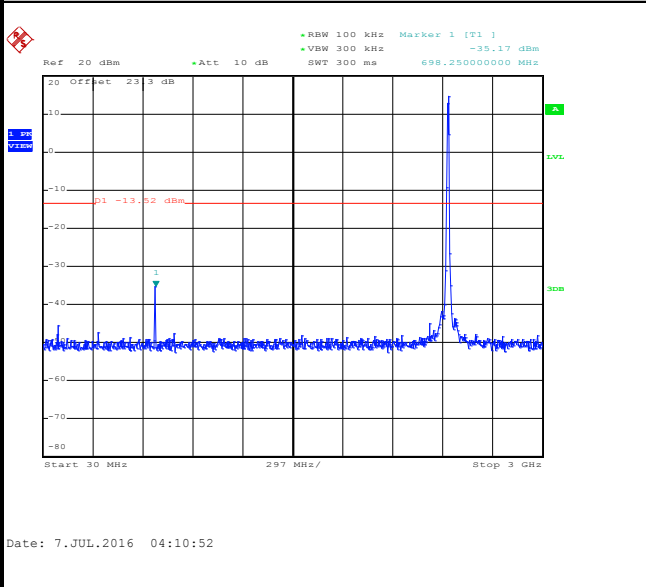

Spurious Emission 2GHz~25GHz

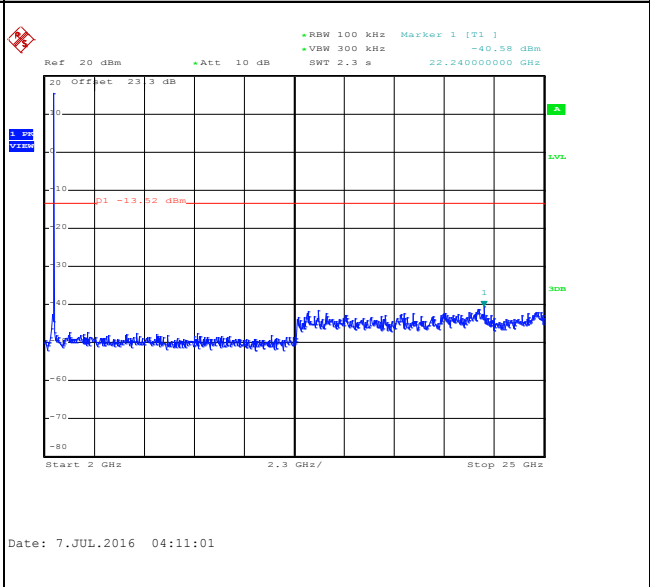



Number of TX :	3	Ant. :	1
Test Mode :	802.11b	Temperature :	21~25°C
Test Band :	2.4GHz High	Relative Humidity :	51~54%
Test Channel :	11	Test Engineer :	Derek Hsu

WLAN 802.11b Channel 11

100kHz PSD reference Level

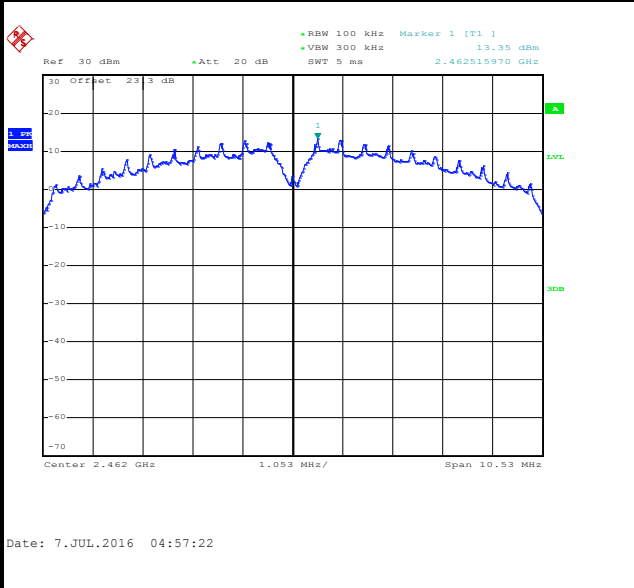

High Channel Plot

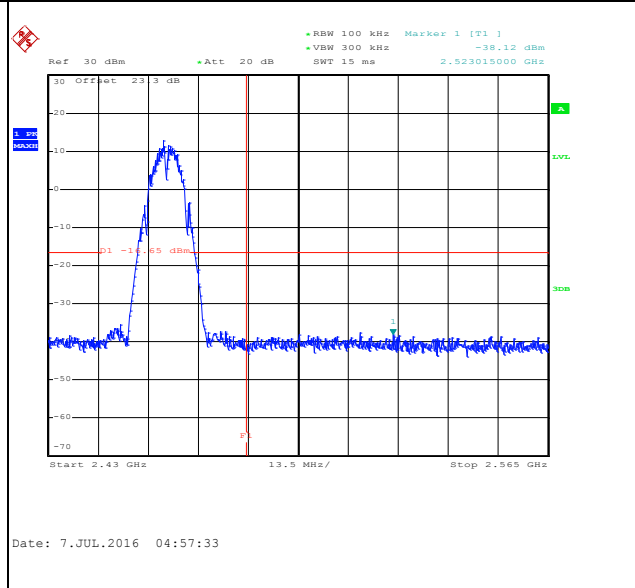

Spurious Emission 30MHz~3GHz

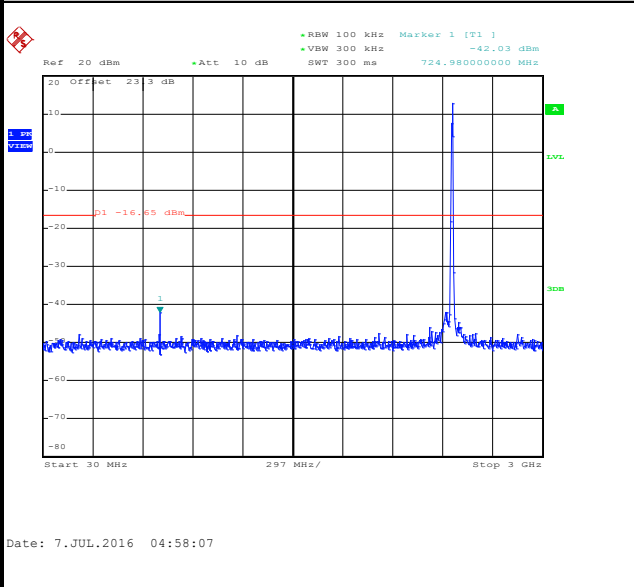

Spurious Emission 2GHz~25GHz

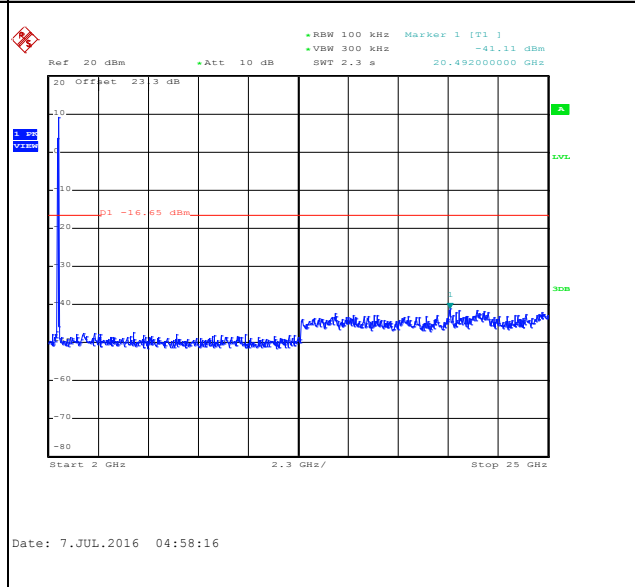



Number of TX :	3	Ant. :	1
Test Mode :	802.11g	Temperature :	21~25°C
Test Band :	2.4GHz Low	Relative Humidity :	51~54%
Test Channel :	01	Test Engineer :	Derek Hsu

WLAN 802.11g Channel 01

100kHz PSD reference Level

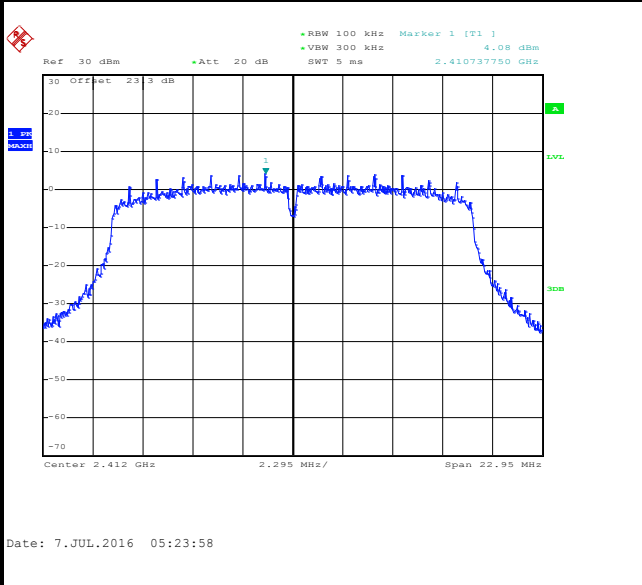

Low Channel Plot

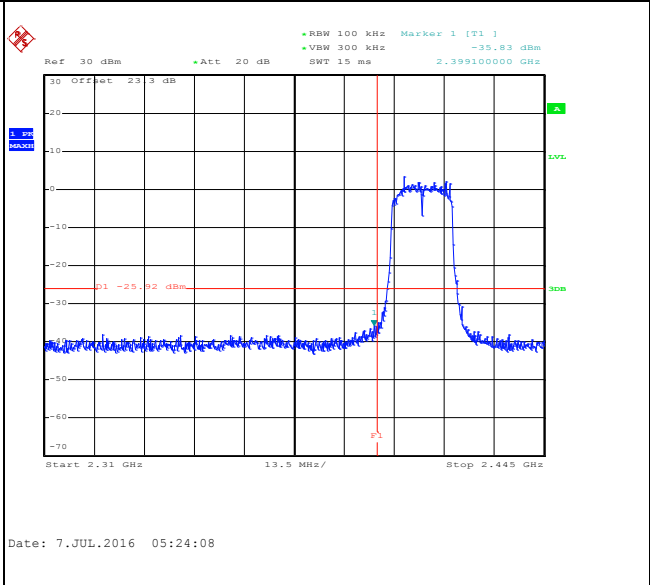

Spurious Emission 30MHz~3GHz

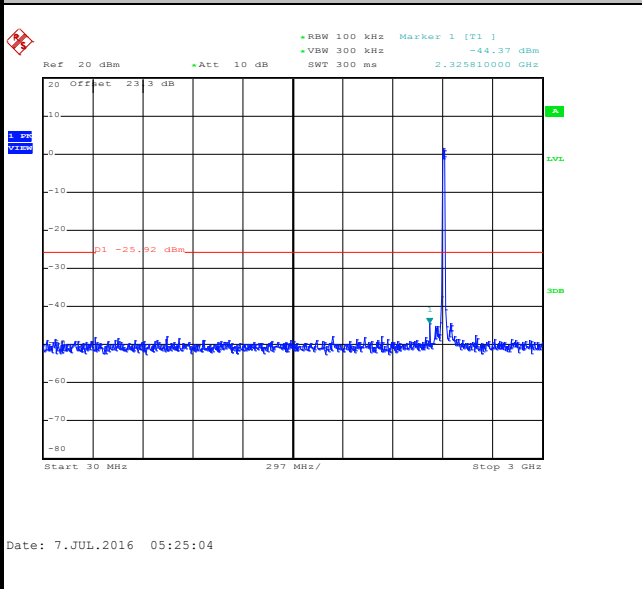

Spurious Emission 2GHz~25GHz

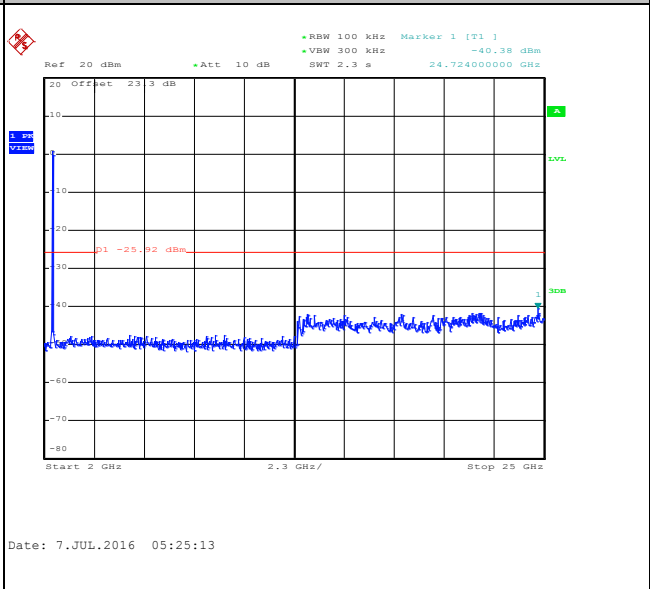



Number of TX :	3	Ant. :	1
Test Mode :	802.11g	Temperature :	21~25°C
Test Band :	2.4GHz Mid	Relative Humidity :	51~54%
Test Channel :	06	Test Engineer :	Derek Hsu

WLAN 802.11g Channel 06

100kHz PSD reference Level

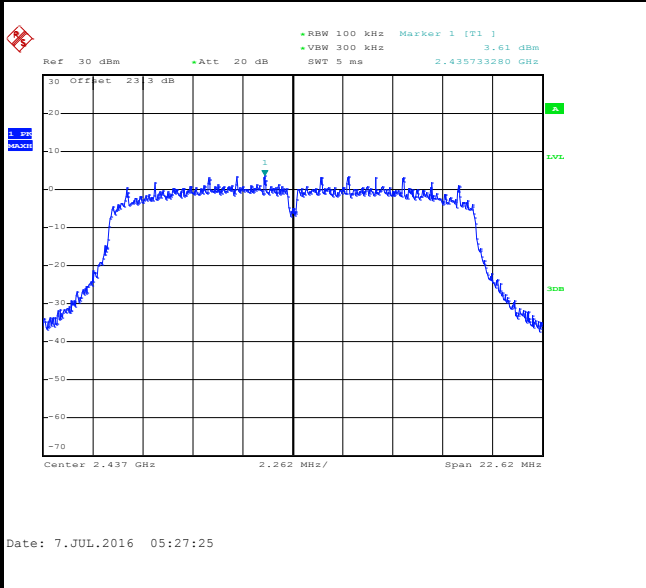

Spurious Emission 30MHz~3GHz

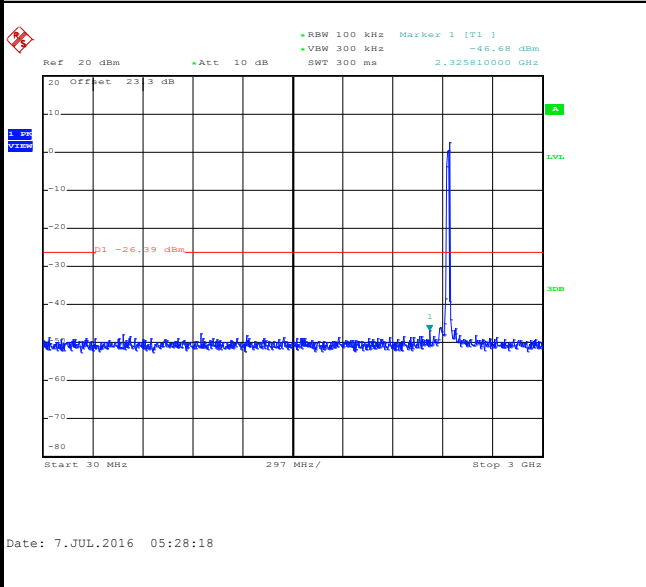

Spurious Emission 2GHz~25GHz

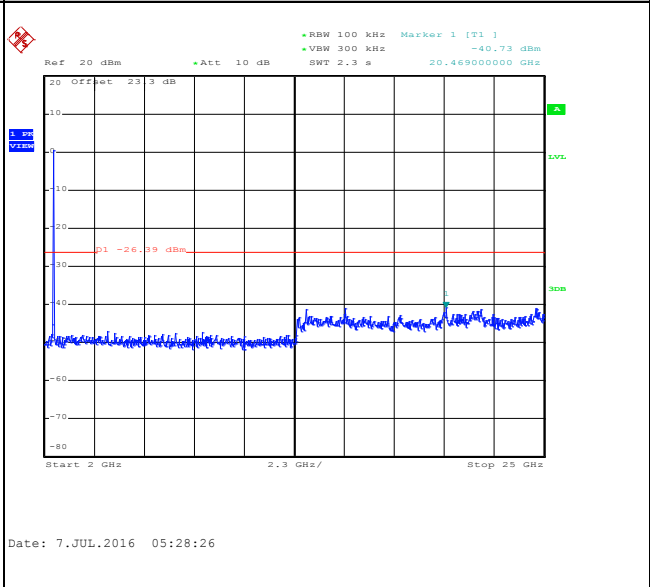



Number of TX :	3	Ant. :	1
Test Mode :	802.11g	Temperature :	21~25°C
Test Band :	2.4GHz High	Relative Humidity :	51~54%
Test Channel :	11	Test Engineer :	Derek Hsu

WLAN 802.11g Channel 11

100kHz PSD reference Level

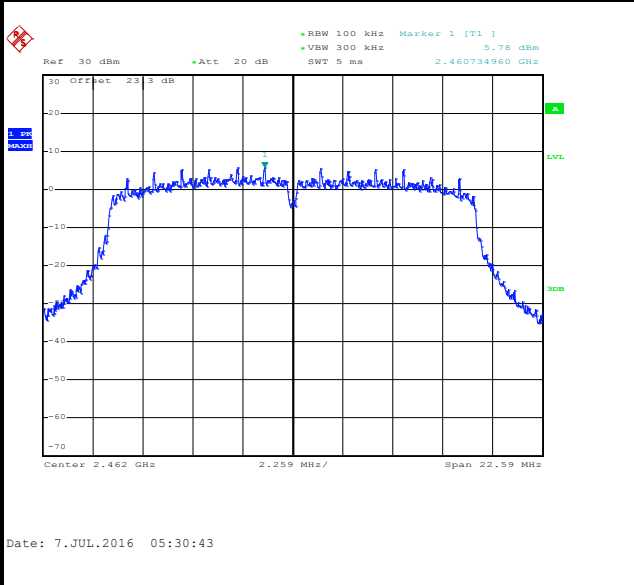

High Channel Plot

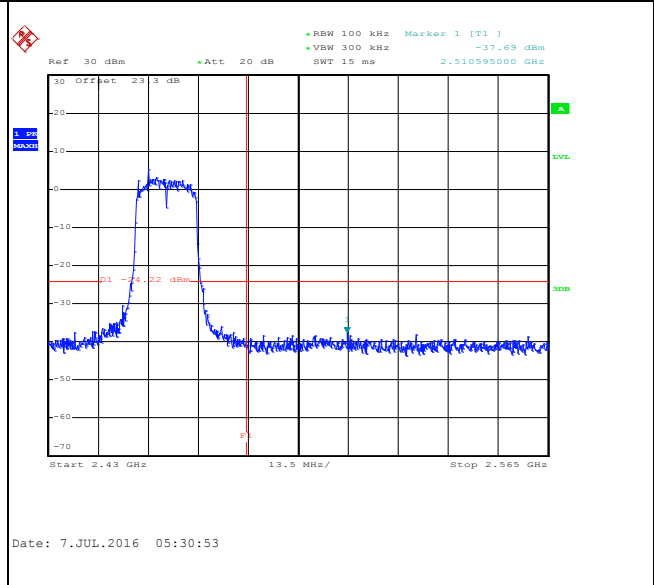

Spurious Emission 30MHz~3GHz

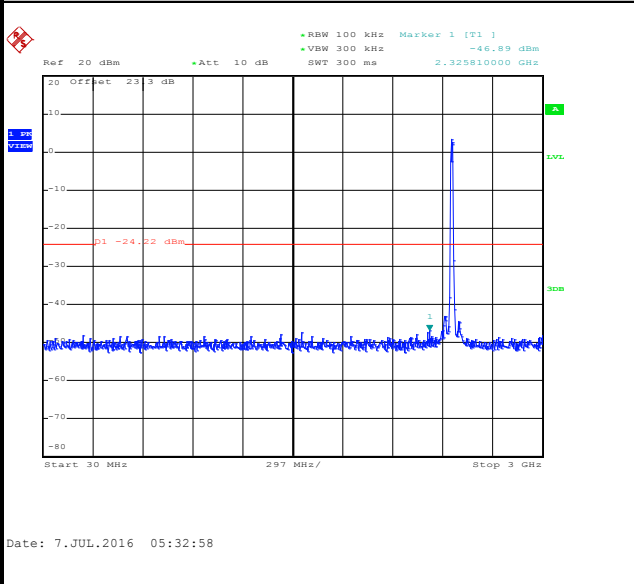

Spurious Emission 2GHz~25GHz

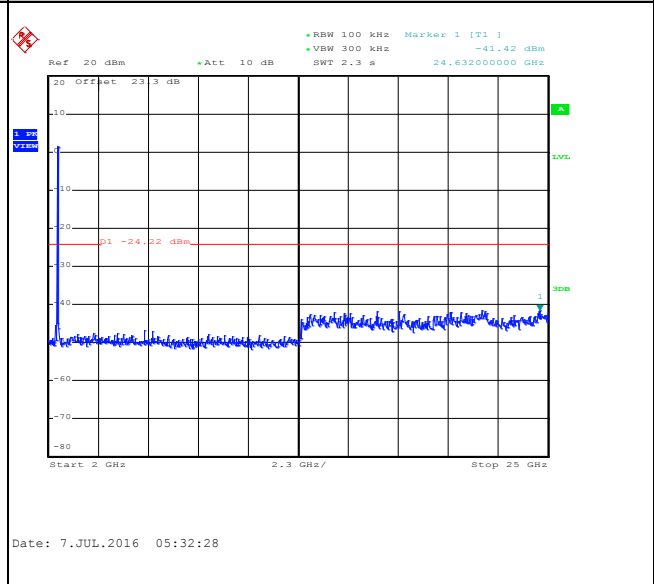



Number of TX :	3	Ant. :	1
Test Mode :	802.11n HT20	Temperature :	21~25°C
Test Band :	2.4GHz Low	Relative Humidity :	51~54%
Test Channel :	01	Test Engineer :	Derek Hsu

WLAN 802.11n HT20 Channel 01

100kHz PSD reference Level

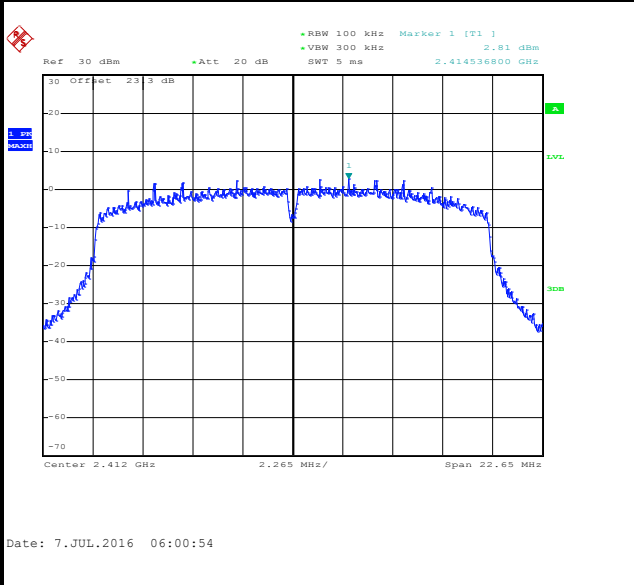

Low Channel Plot

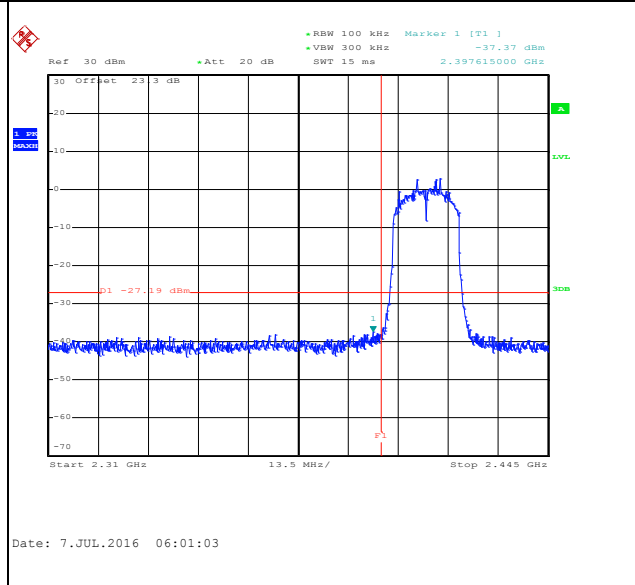

Spurious Emission 30MHz~3GHz

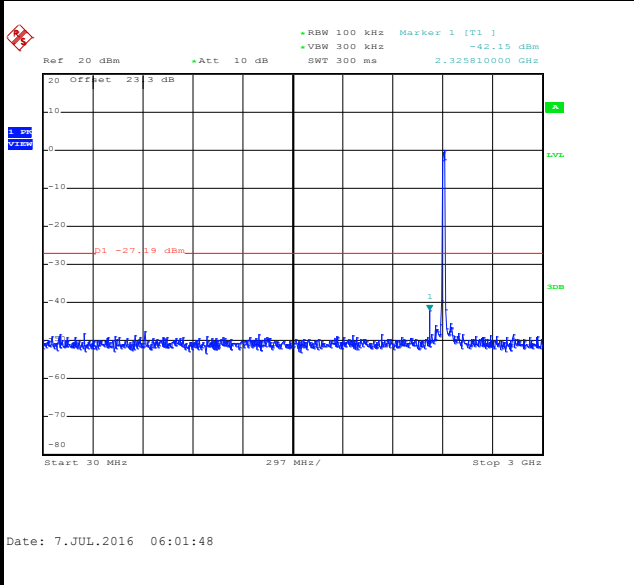

Spurious Emission 2GHz~25GHz

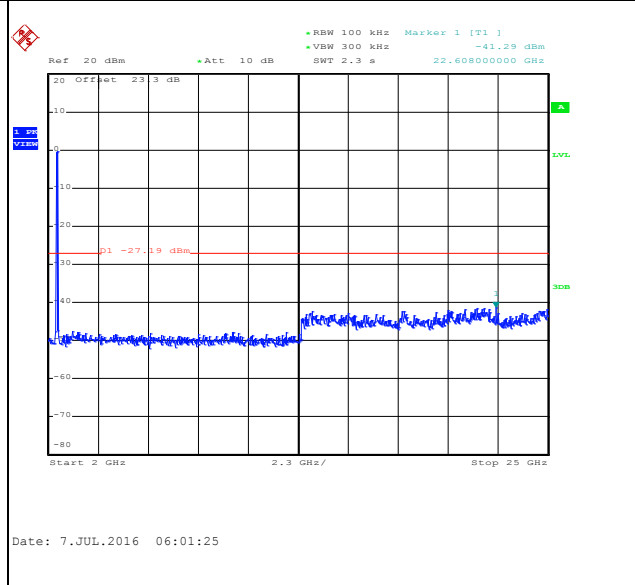



Number of TX :	3	Ant. :	1
Test Mode :	802.11n HT20	Temperature :	21~25°C
Test Band :	2.4GHz Mid	Relative Humidity :	51~54%
Test Channel :	06	Test Engineer :	Derek Hsu

WLAN 802.11n HT20 Channel 06

100kHz PSD reference Level

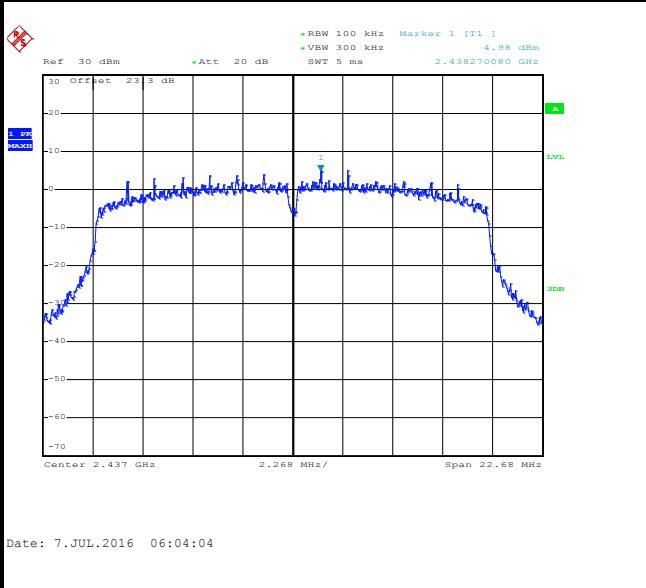

Spurious Emission 30MHz~3GHz

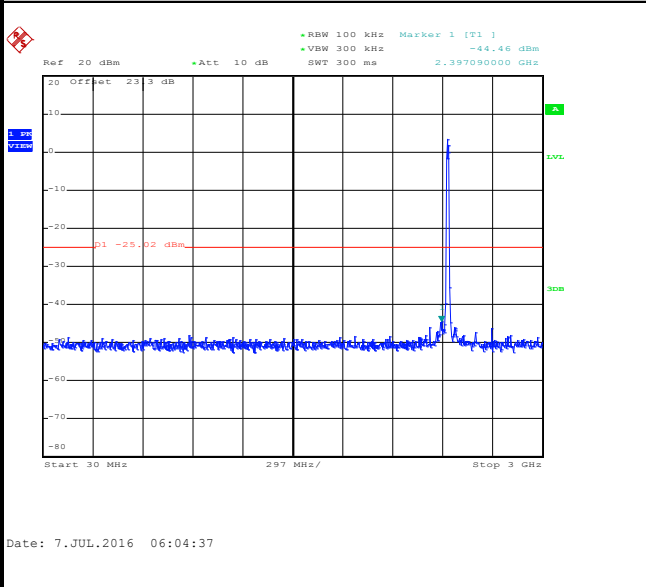

Spurious Emission 2GHz~25GHz

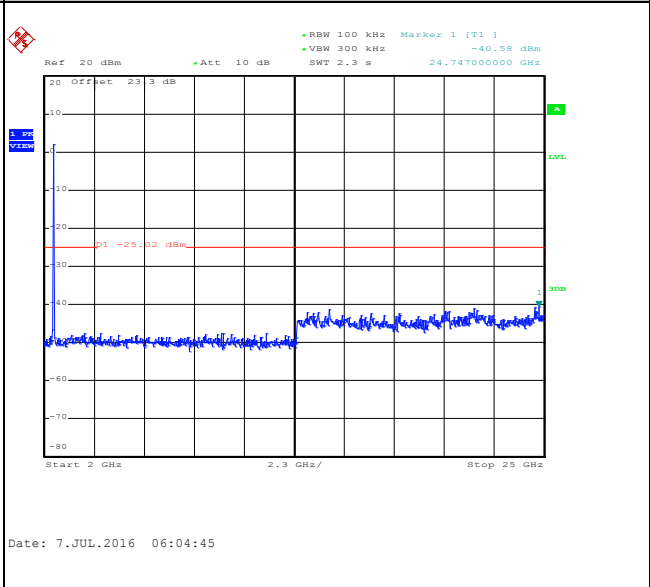



Number of TX :	3	Ant. :	1
Test Mode :	802.11n HT20	Temperature :	21~25°C
Test Band :	2.4GHz High	Relative Humidity :	51~54%
Test Channel :	11	Test Engineer :	Derek Hsu

WLAN 802.11n HT20 Channel 11

100kHz PSD reference Level

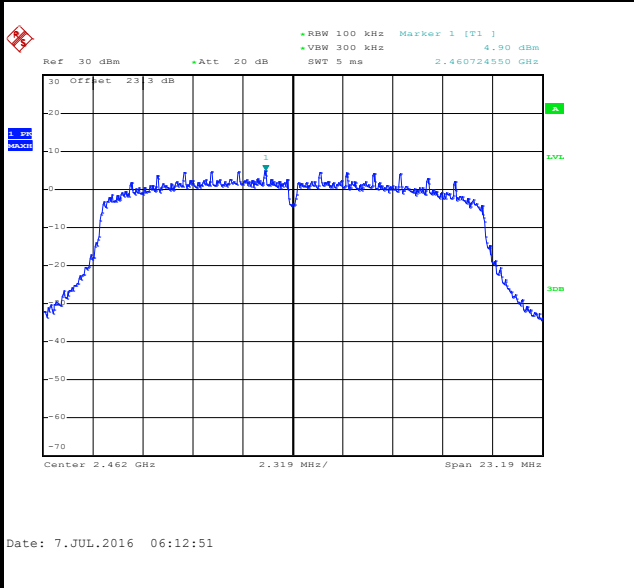

High Channel Plot

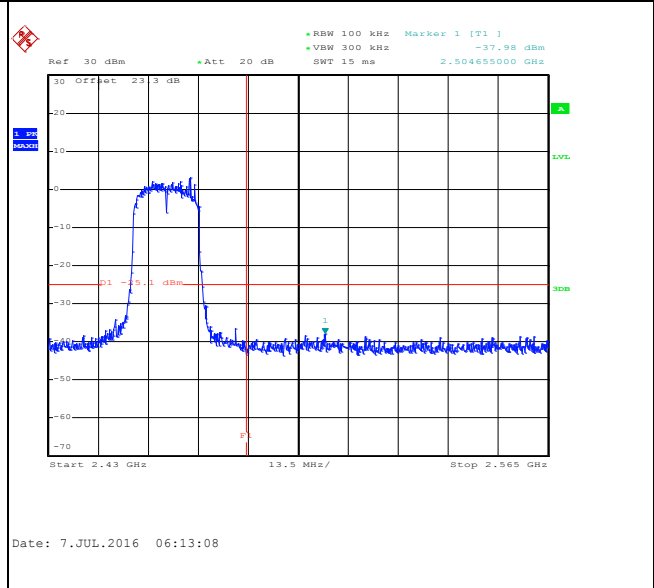

Spurious Emission 30MHz~3GHz

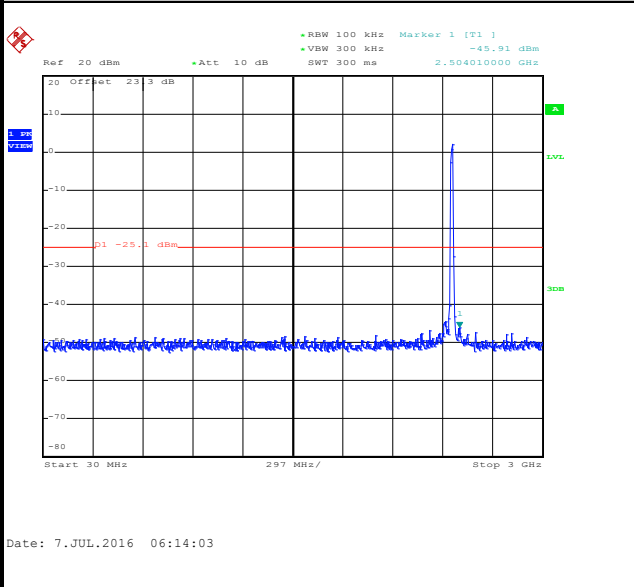

Spurious Emission 2GHz~25GHz

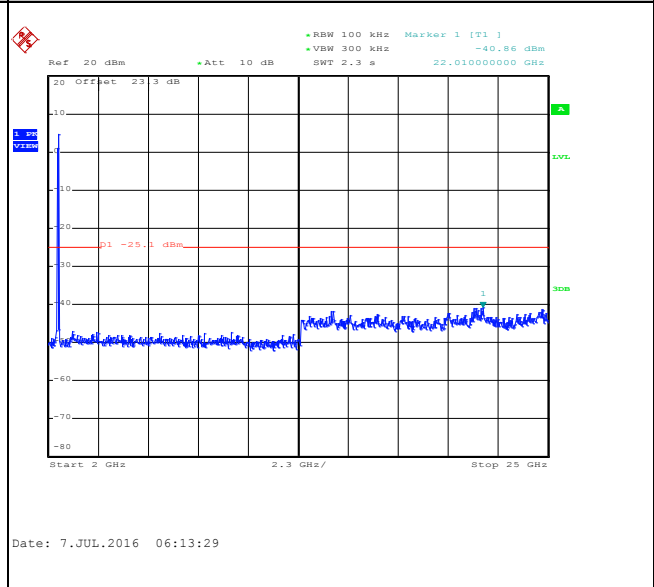



Number of TX :	3	Ant. :	1
Test Mode :	802.11n HT40	Temperature :	21~25°C
Test Band :	2.4GHz Low	Relative Humidity :	51~54%
Test Channel :	03	Test Engineer :	Derek Hsu

WLAN 802.11n HT40 Channel 03

100kHz PSD reference Level

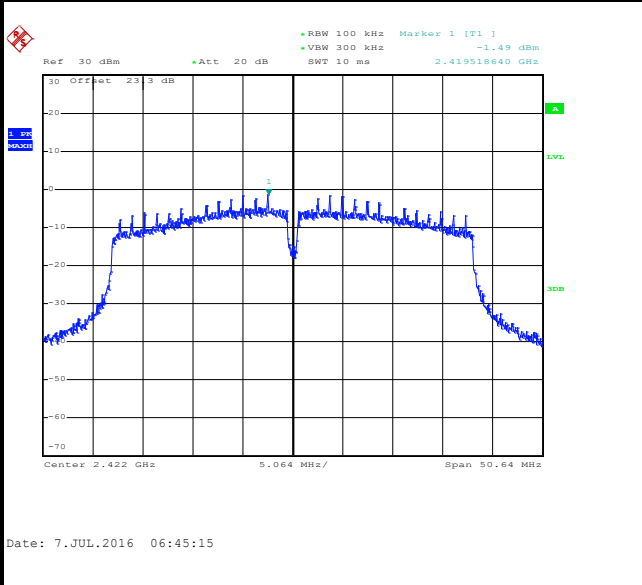

Low Channel Plot

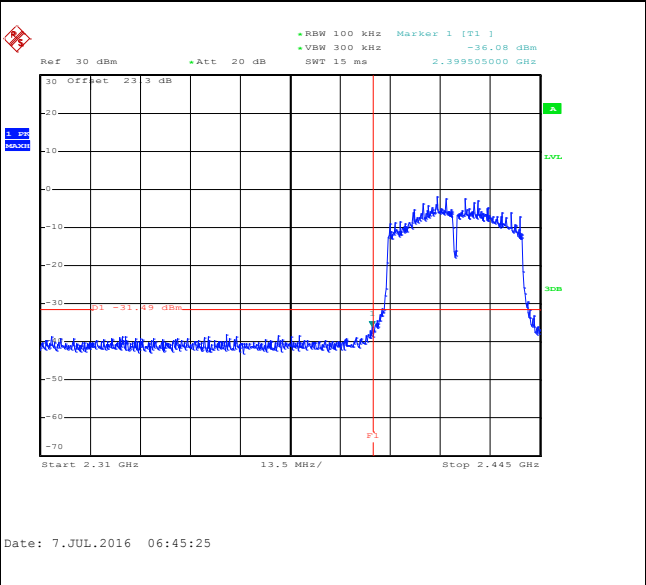

Spurious Emission 30MHz~3GHz

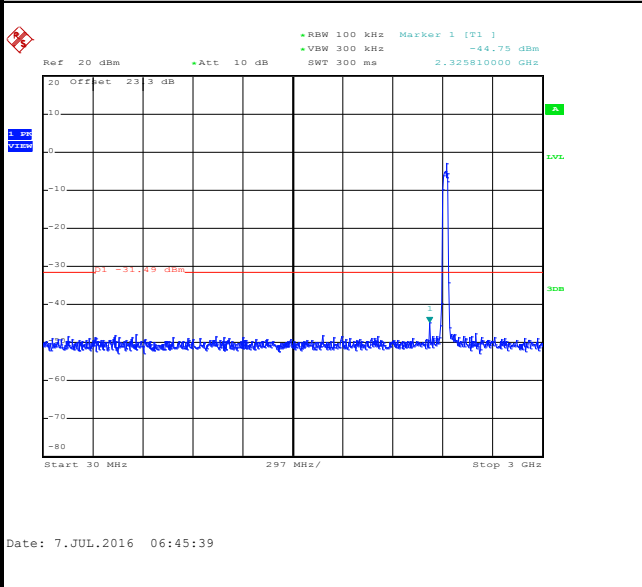

Spurious Emission 2GHz~25GHz

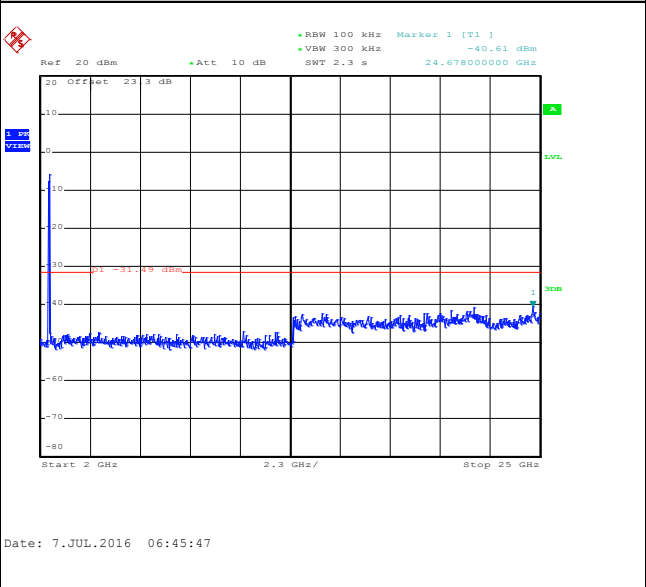



Number of TX :	3	Ant. :	1
Test Mode :	802.11n HT40	Temperature :	21~25°C
Test Band :	2.4GHz Mid	Relative Humidity :	51~54%
Test Channel :	06	Test Engineer :	Derek Hsu

WLAN 802.11n HT40 Channel 06

100kHz PSD reference Level

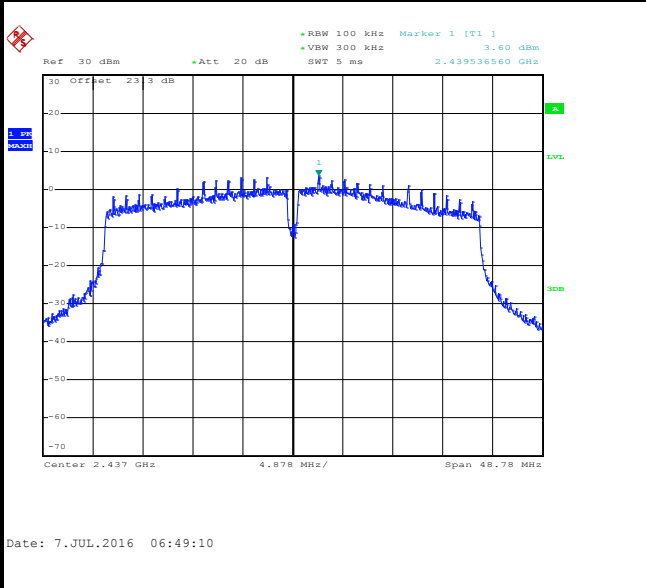

Spurious Emission 30MHz~3GHz

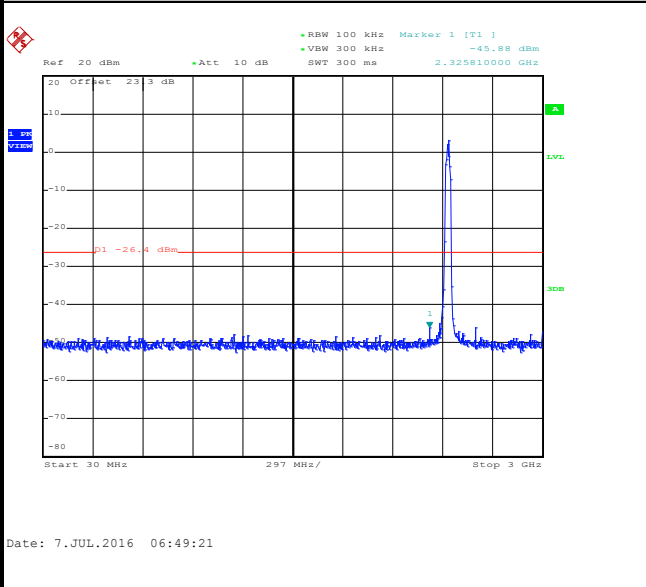

Spurious Emission 2GHz~25GHz

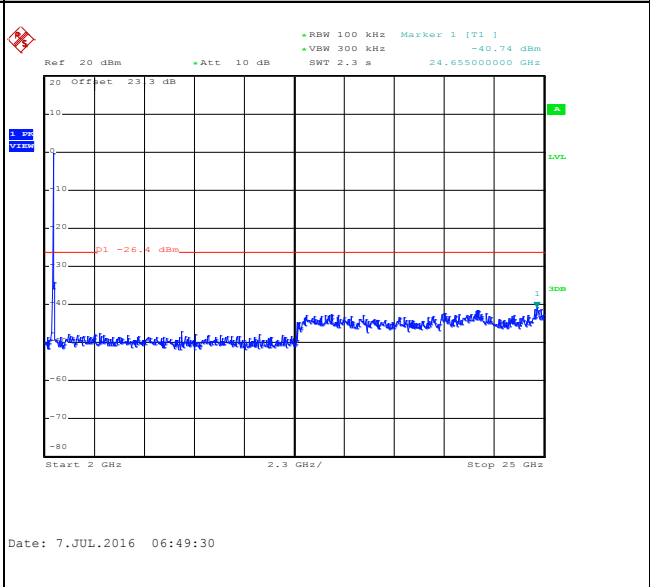



Number of TX :	3	Ant. :	1
Test Mode :	802.11n HT40	Temperature :	21~25°C
Test Band :	2.4GHz High	Relative Humidity :	51~54%
Test Channel :	09	Test Engineer :	Derek Hsu

WLAN 802.11n HT40 Channel 09

100kHz PSD reference Level

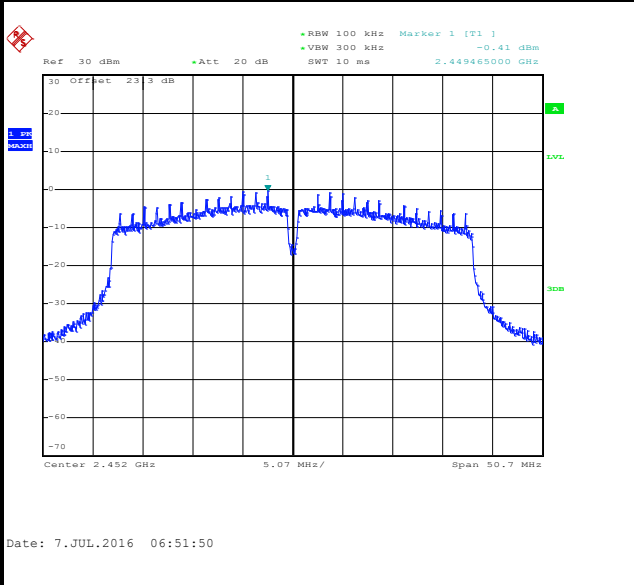

High Channel Plot

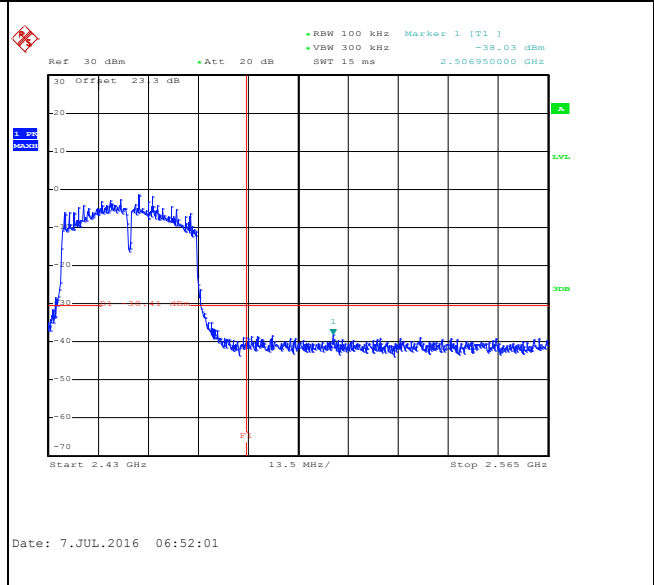

Spurious Emission 30MHz~3GHz

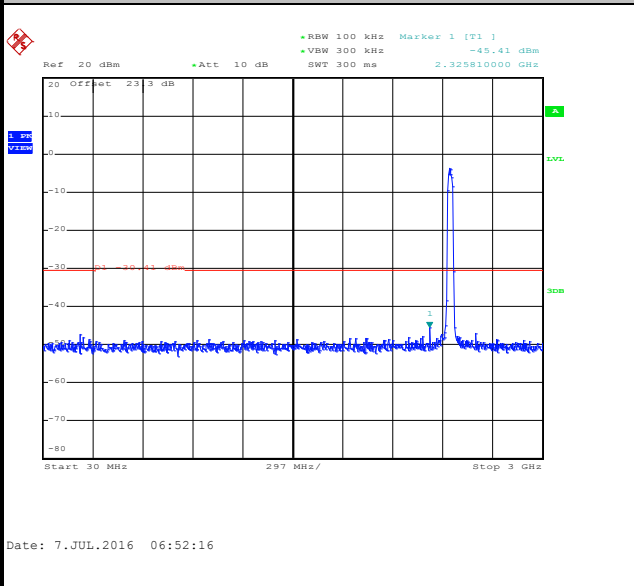

Spurious Emission 2GHz~25GHz

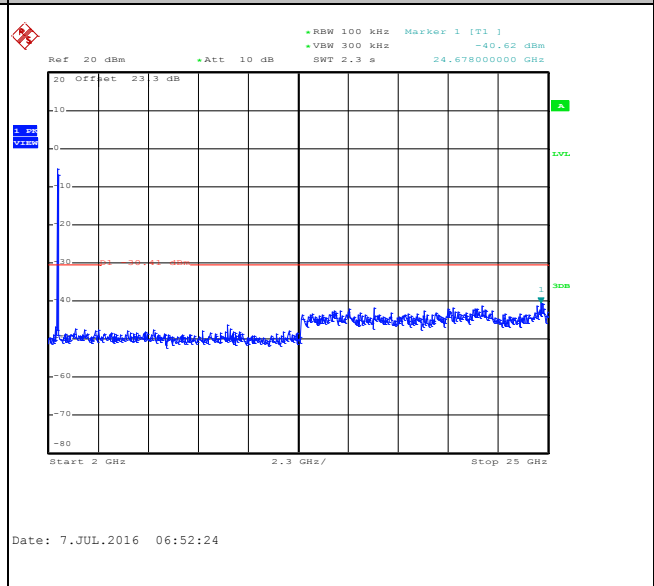



Number of TX = 3, Ant. 2 (Measured)

Number of TX :	3	Ant. :	2
Test Mode :	802.11b	Temperature :	21~25°C
Test Band :	2.4GHz Low	Relative Humidity :	51~54%
Test Channel :	01	Test Engineer :	Derek Hsu

WLAN 802.11b Channel 01

100kHz PSD reference Level

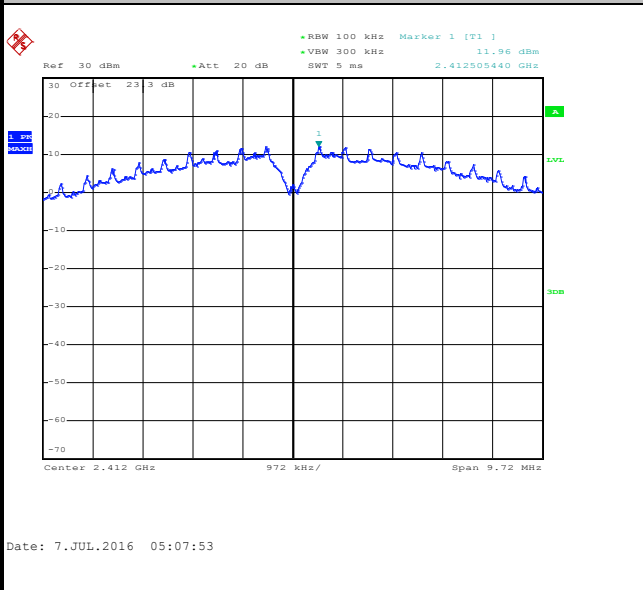

Low Channel Plot

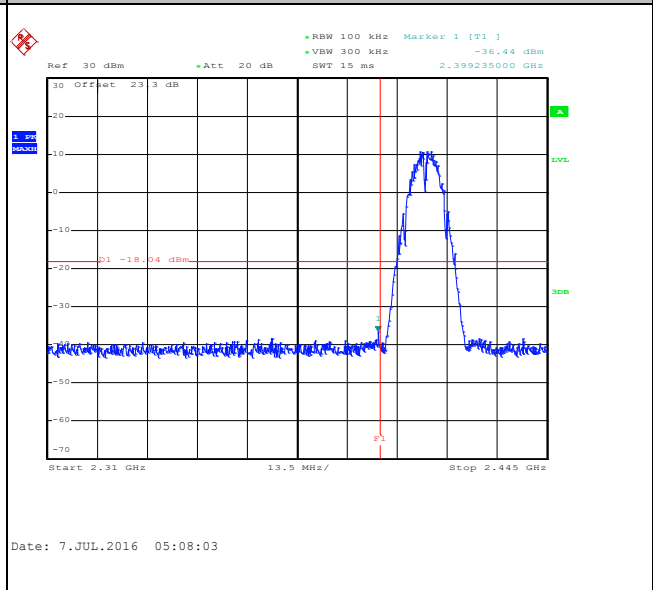

Spurious Emission 30MHz~3GHz

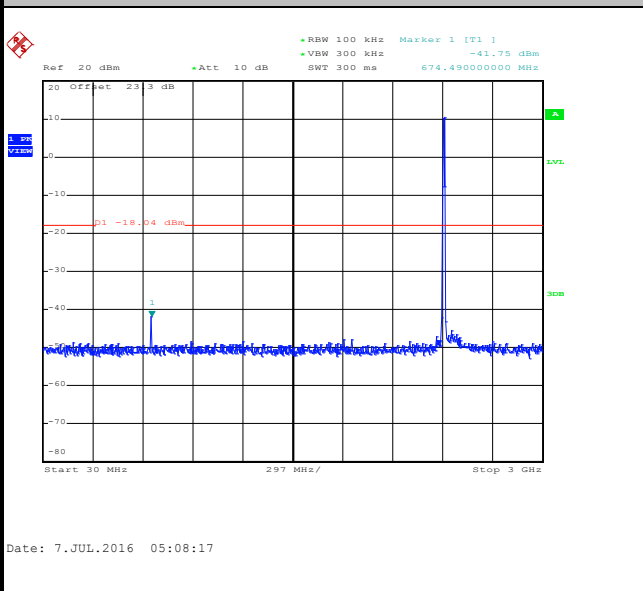

Spurious Emission 2GHz~25GHz

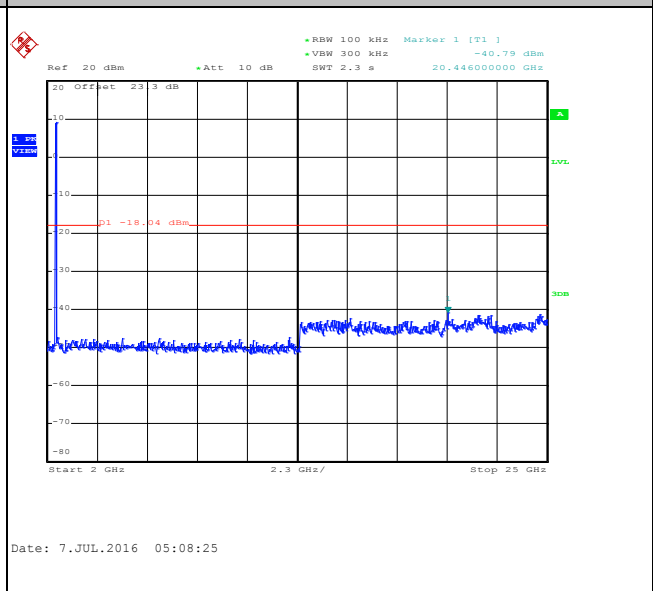



Number of TX :	3	Ant. :	2
Test Mode :	802.11b	Temperature :	21~25°C
Test Band :	2.4GHz Mid	Relative Humidity :	51~54%
Test Channel :	06	Test Engineer :	Derek Hsu

WLAN 802.11b Channel 06

100kHz PSD reference Level

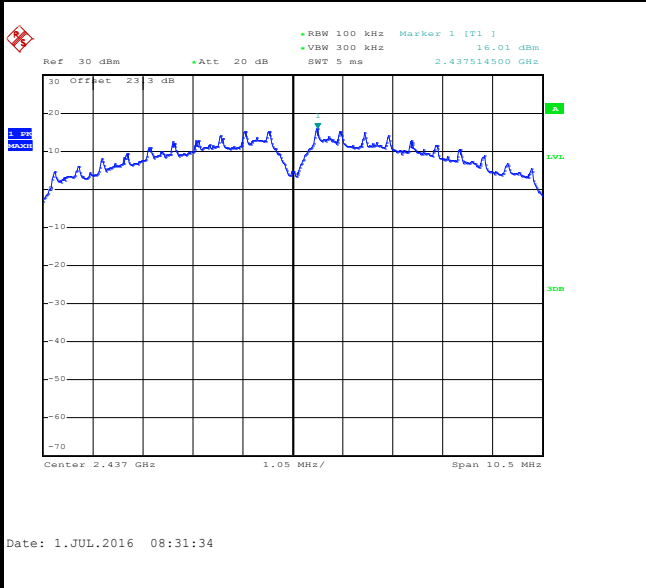

Spurious Emission 30MHz~3GHz

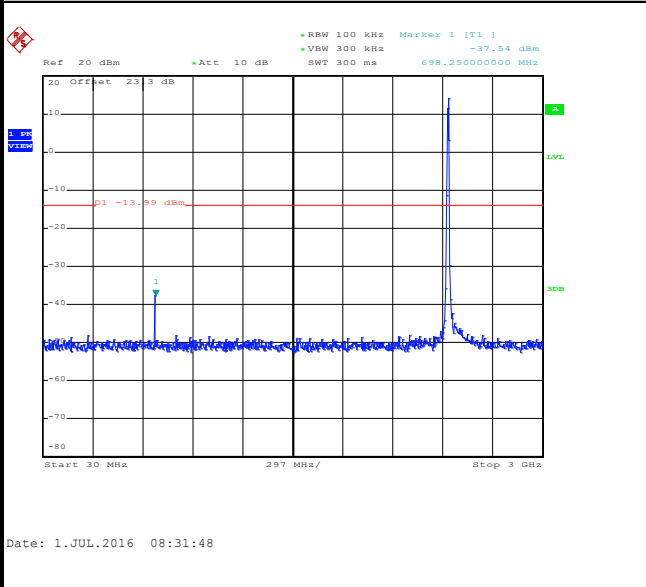

Spurious Emission 2GHz~25GHz

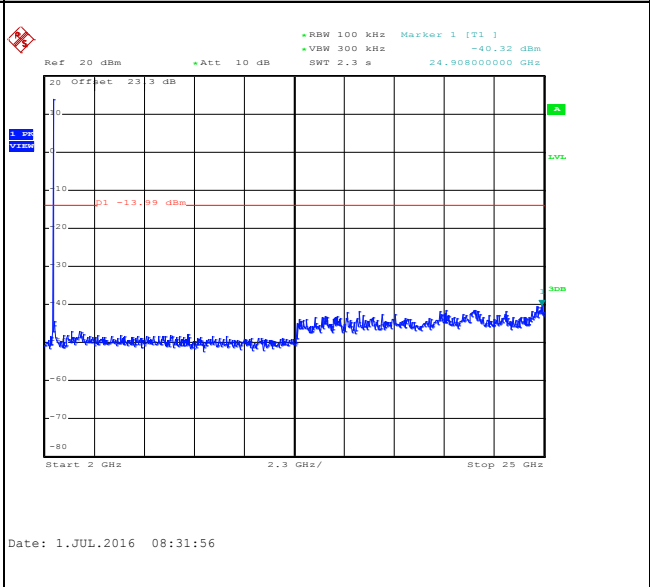



Number of TX :	3	Ant. :	2
Test Mode :	802.11b	Temperature :	21~25°C
Test Band :	2.4GHz High	Relative Humidity :	51~54%
Test Channel :	11	Test Engineer :	Derek Hsu

WLAN 802.11b Channel 11

100kHz PSD reference Level

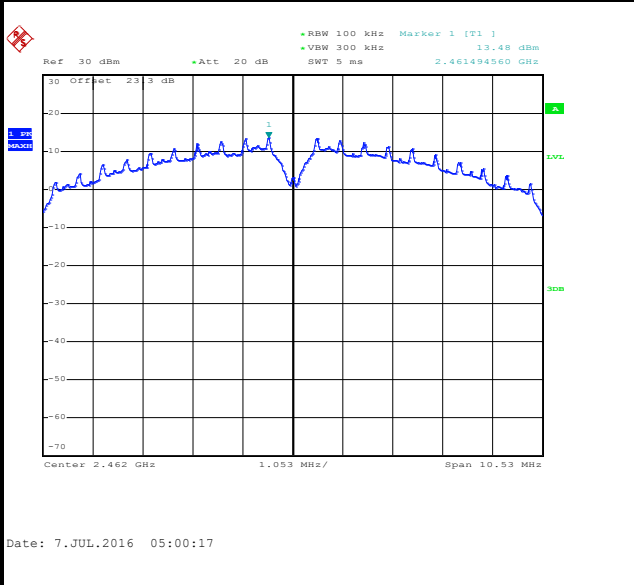

High Channel Plot

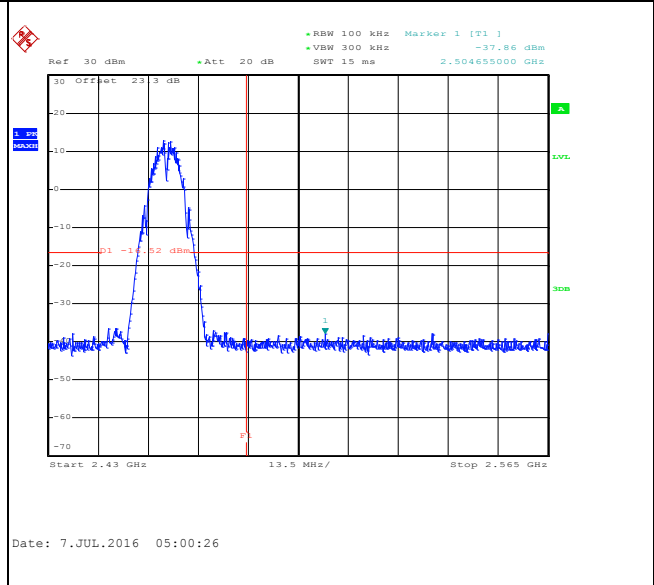

Spurious Emission 30MHz~3GHz

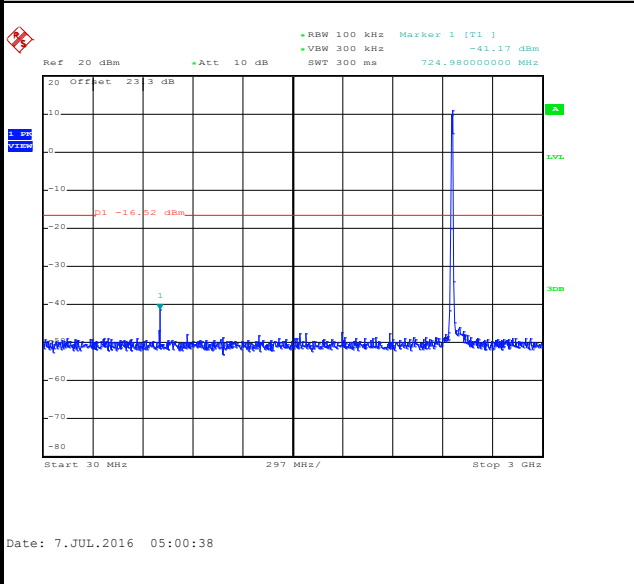

Spurious Emission 2GHz~25GHz

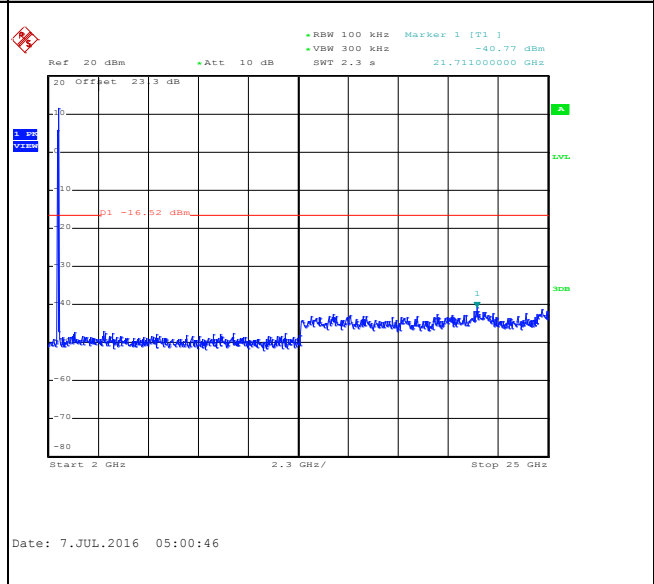



Number of TX :	3	Ant. :	2
Test Mode :	802.11g	Temperature :	21~25°C
Test Band :	2.4GHz Low	Relative Humidity :	51~54%
Test Channel :	01	Test Engineer :	Derek Hsu

WLAN 802.11g Channel 01

100kHz PSD reference Level

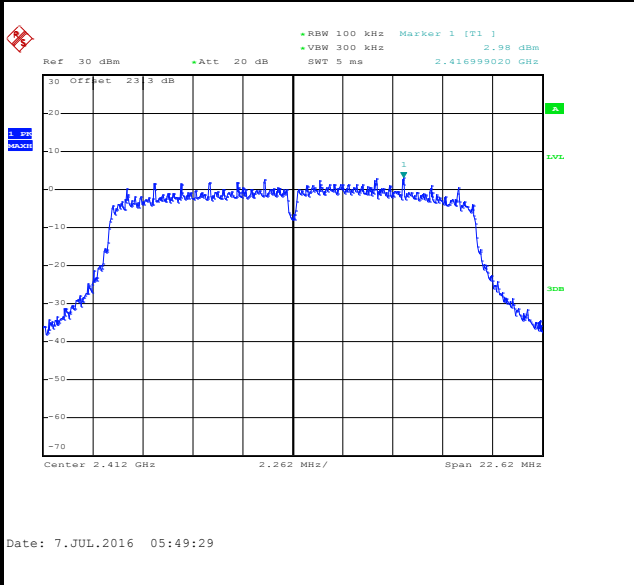

Low Channel Plot

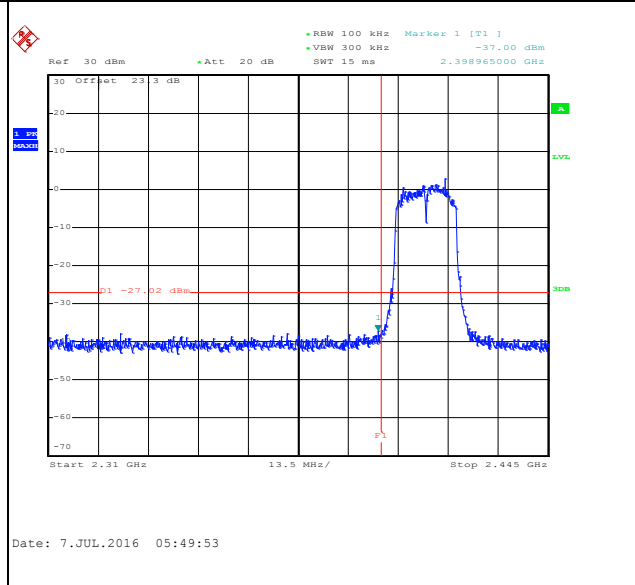

Spurious Emission 30MHz~3GHz

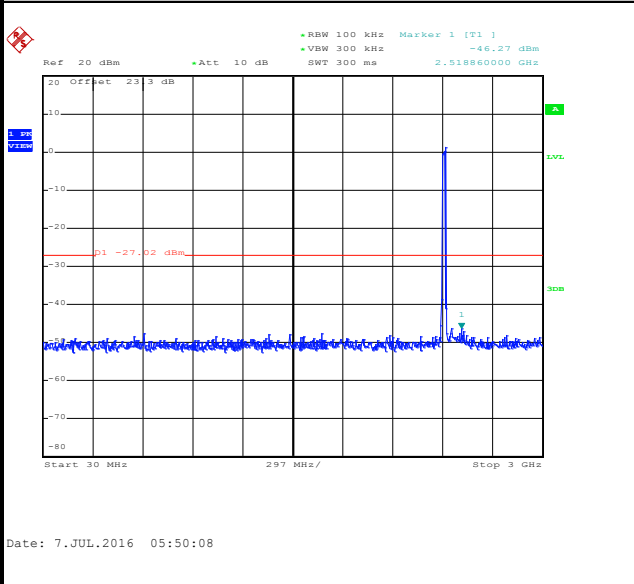

Spurious Emission 2GHz~25GHz

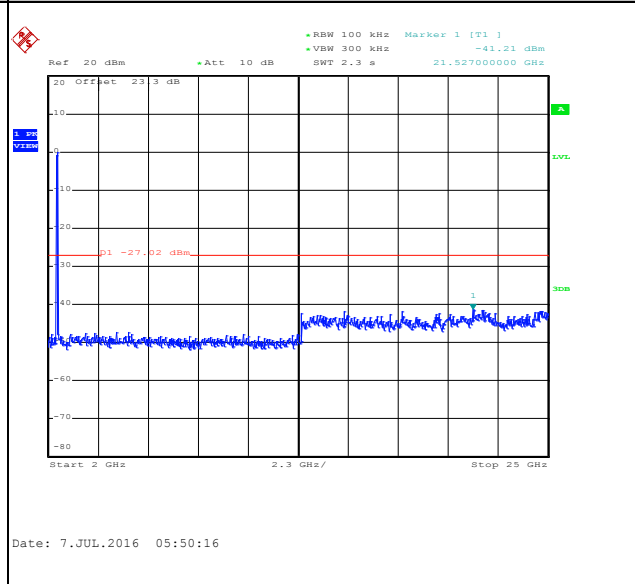



Number of TX :	3	Ant. :	2
Test Mode :	802.11g	Temperature :	21~25°C
Test Band :	2.4GHz Mid	Relative Humidity :	51~54%
Test Channel :	06	Test Engineer :	Derek Hsu

WLAN 802.11g Channel 06

100kHz PSD reference Level

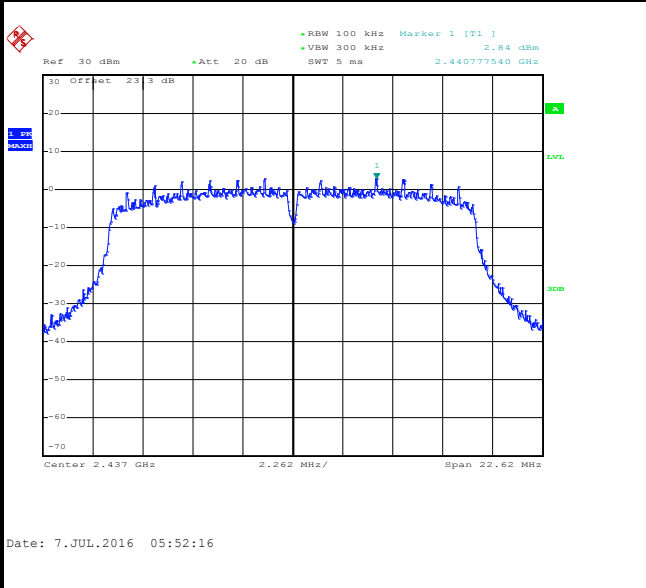

Spurious Emission 30MHz~3GHz

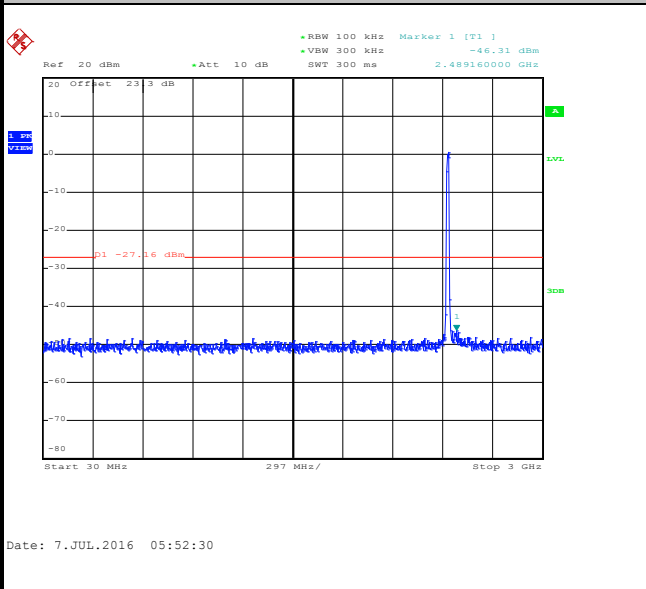

Spurious Emission 2GHz~25GHz

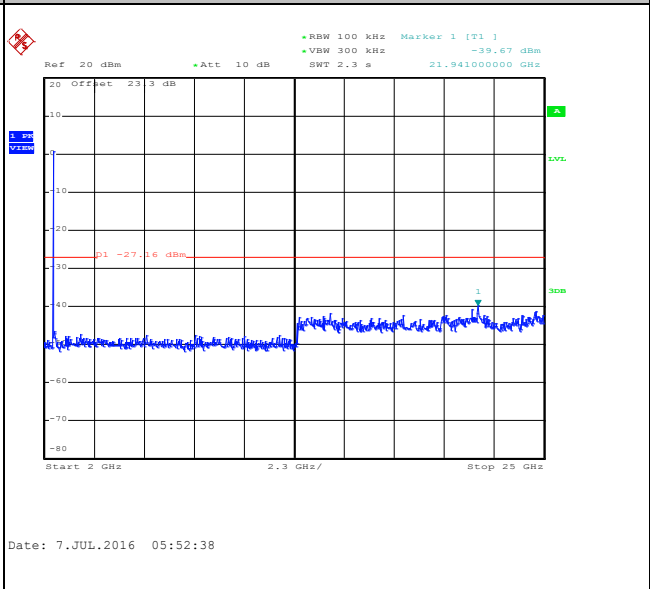



Number of TX :	3	Ant. :	2
Test Mode :	802.11g	Temperature :	21~25°C
Test Band :	2.4GHz High	Relative Humidity :	51~54%
Test Channel :	11	Test Engineer :	Derek Hsu

WLAN 802.11g Channel 11

100kHz PSD reference Level

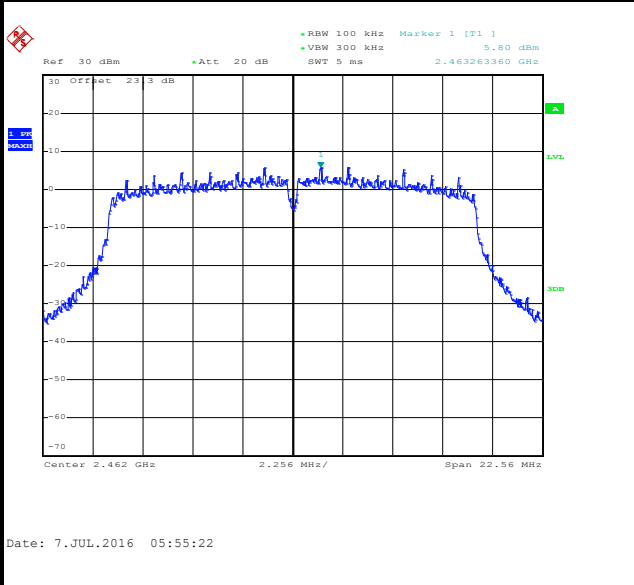

High Channel Plot

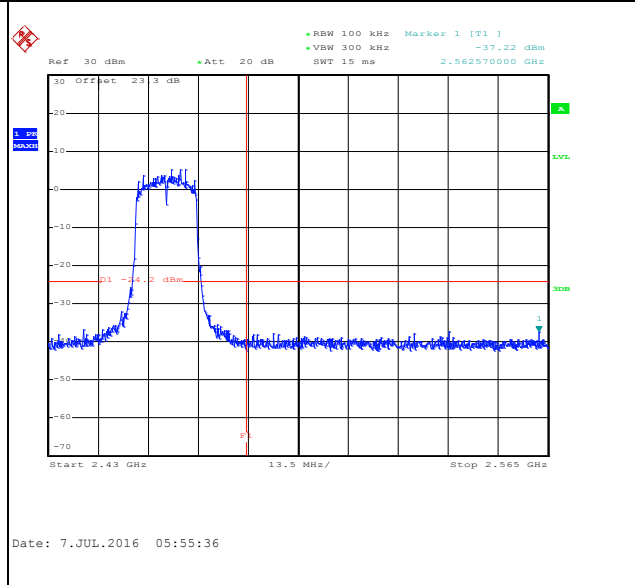

Spurious Emission 30MHz~3GHz

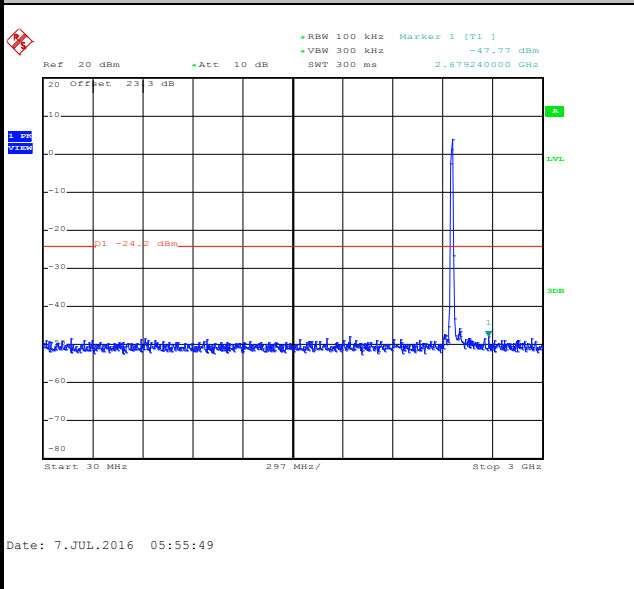

Spurious Emission 2GHz~25GHz

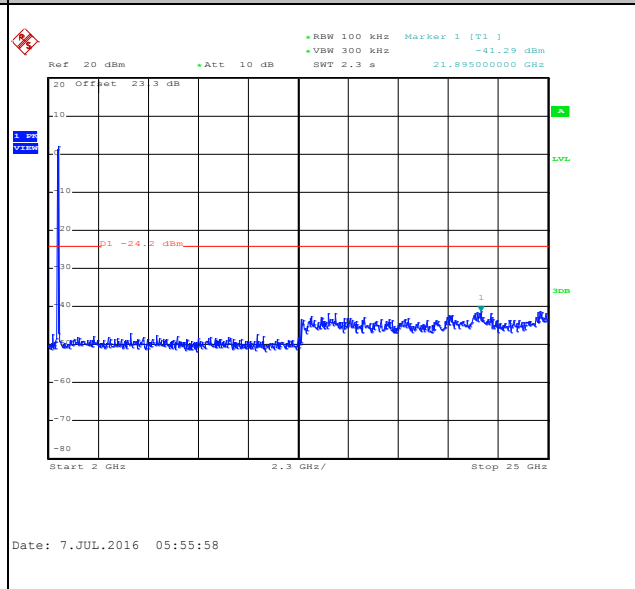



Number of TX :	3	Ant. :	2
Test Mode :	802.11n HT20	Temperature :	21~25°C
Test Band :	2.4GHz Low	Relative Humidity :	51~54%
Test Channel :	01	Test Engineer :	Derek Hsu

WLAN 802.11n HT20 Channel 01

100kHz PSD reference Level

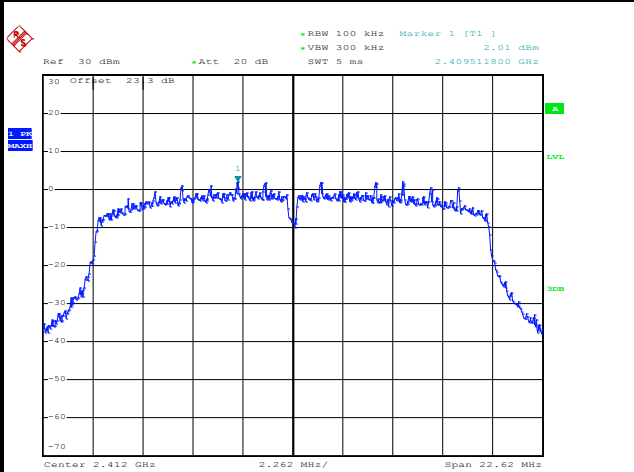

Date: 7.JUL.2016 06:19:40

Low Channel Plot

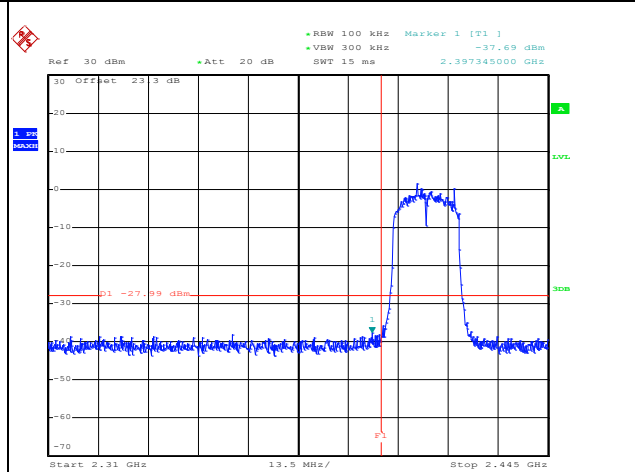

Date: 7.JUL.2016 06:19:52

Spurious Emission 30MHz~3GHz

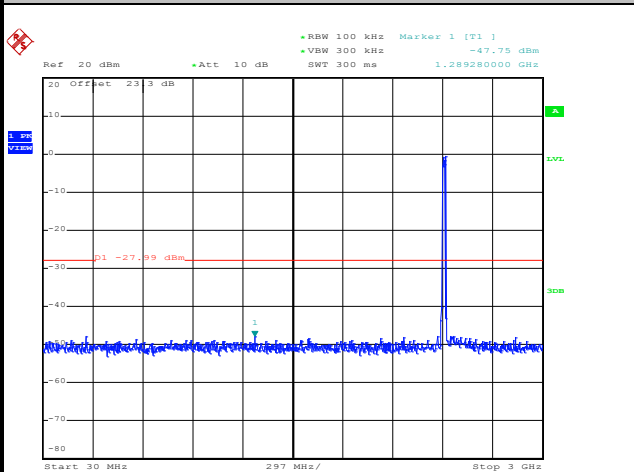

Date: 7.JUL.2016 06:20:46

Spurious Emission 2GHz~25GHz

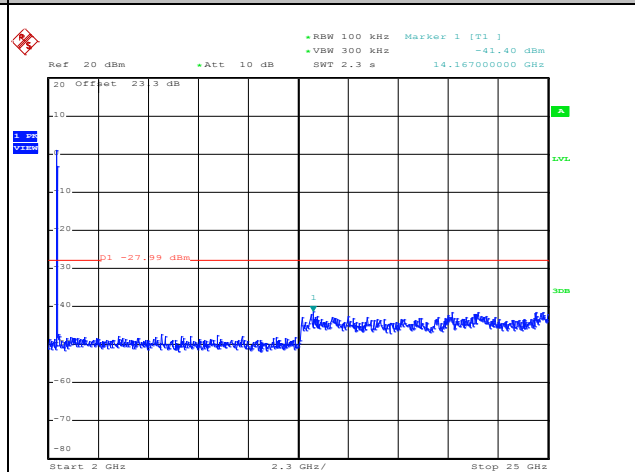

Date: 7.JUL.2016 06:20:14



Number of TX :	3	Ant. :	2
Test Mode :	802.11n HT20	Temperature :	21~25°C
Test Band :	2.4GHz Mid	Relative Humidity :	51~54%
Test Channel :	06	Test Engineer :	Derek Hsu

WLAN 802.11n HT20 Channel 06

100kHz PSD reference Level

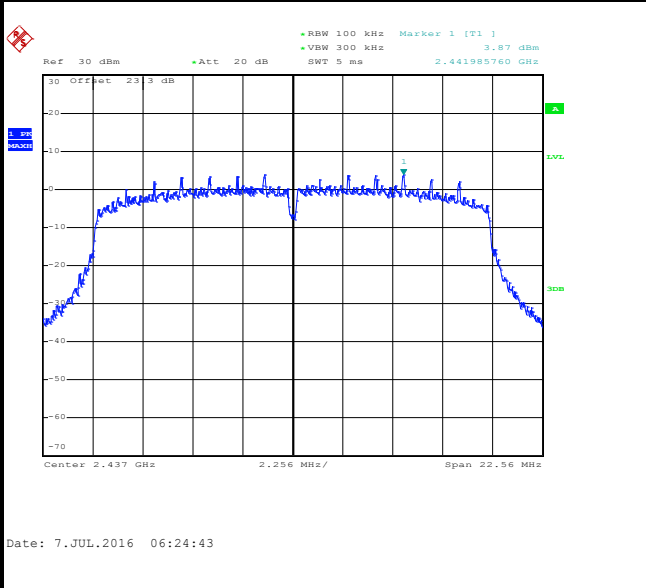

Spurious Emission 30MHz~3GHz

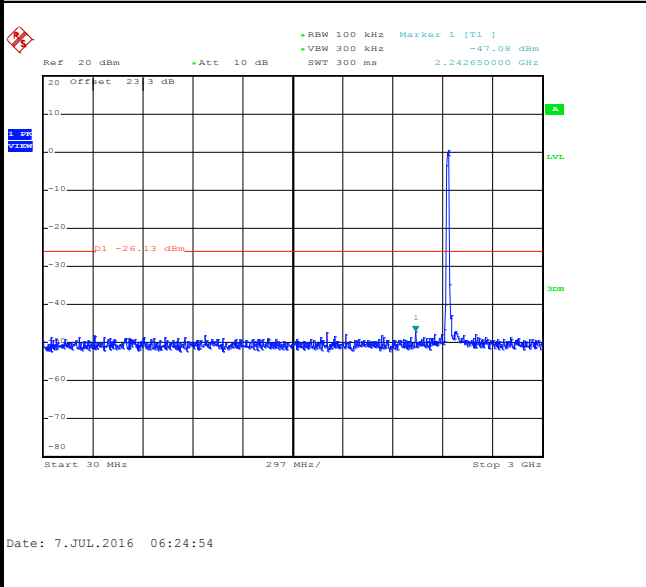

Spurious Emission 2GHz~25GHz

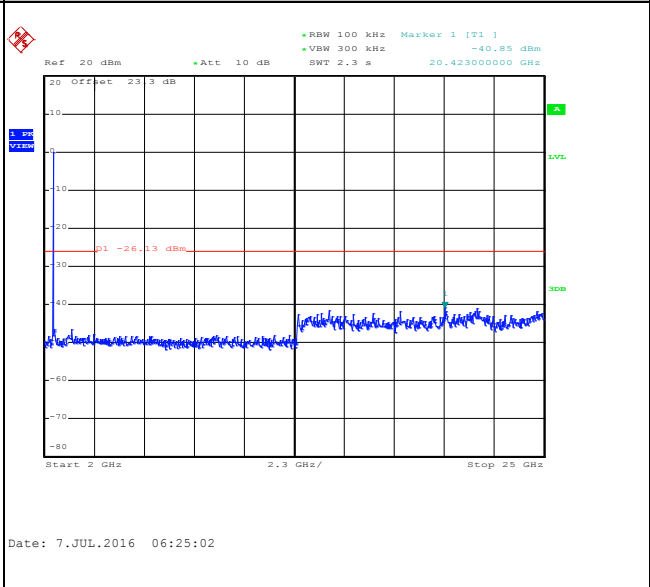



Number of TX :	3	Ant. :	2
Test Mode :	802.11n HT20	Temperature :	21~25°C
Test Band :	2.4GHz High	Relative Humidity :	51~54%
Test Channel :	11	Test Engineer :	Derek Hsu

WLAN 802.11n HT20 Channel 11

100kHz PSD reference Level

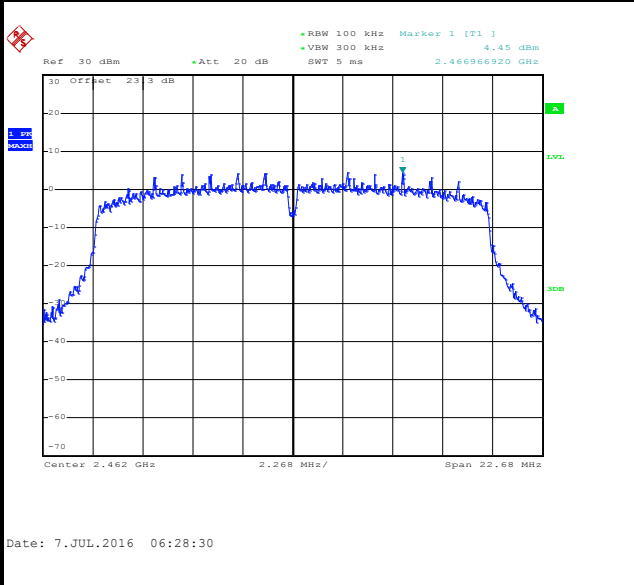

High Channel Plot

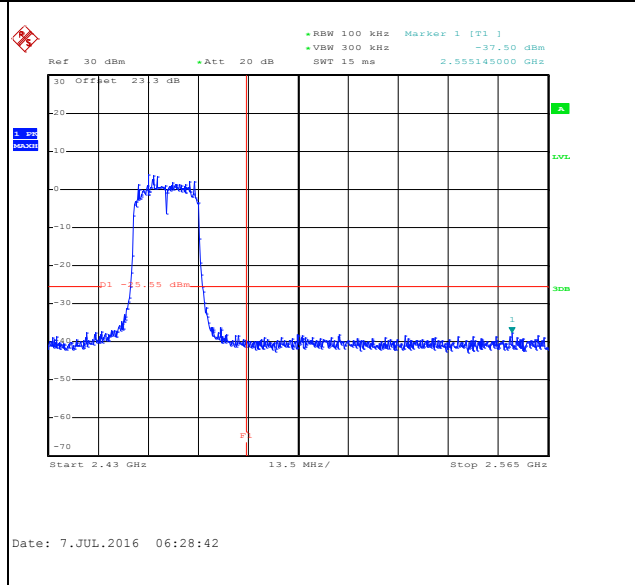

Spurious Emission 30MHz~3GHz

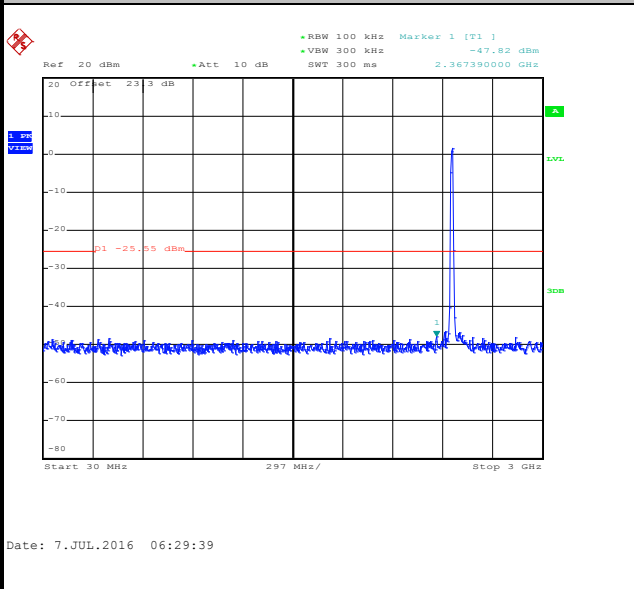

Spurious Emission 2GHz~25GHz

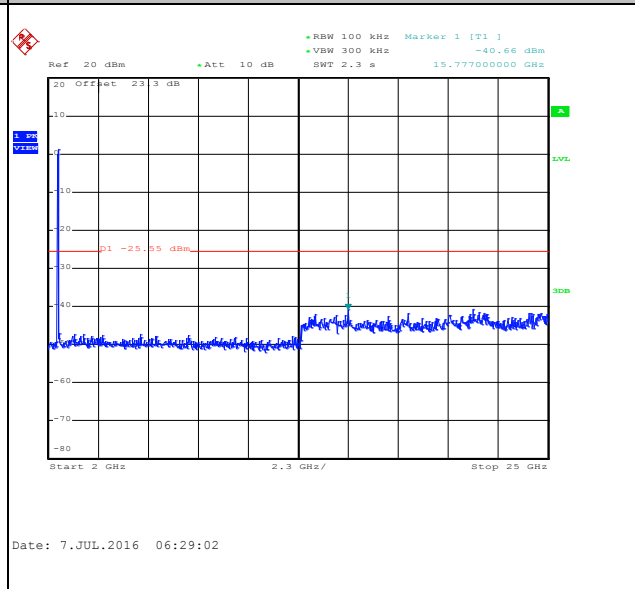



Number of TX :	3	Ant. :	2
Test Mode :	802.11n HT40	Temperature :	21~25°C
Test Band :	2.4GHz Low	Relative Humidity :	51~54%
Test Channel :	03	Test Engineer :	Derek Hsu

WLAN 802.11n HT40 Channel 03

100kHz PSD reference Level

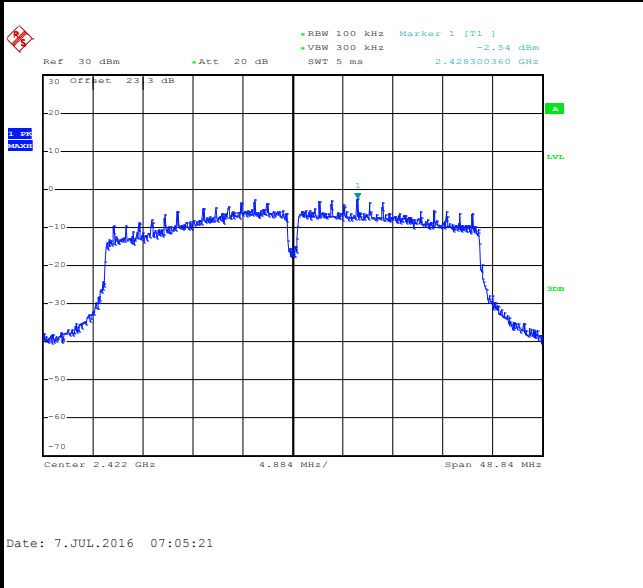

Low Channel Plot

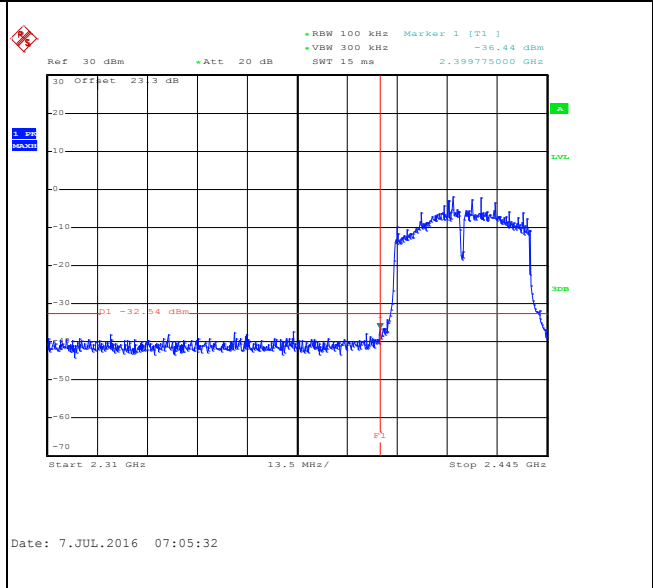

Spurious Emission 30MHz~3GHz

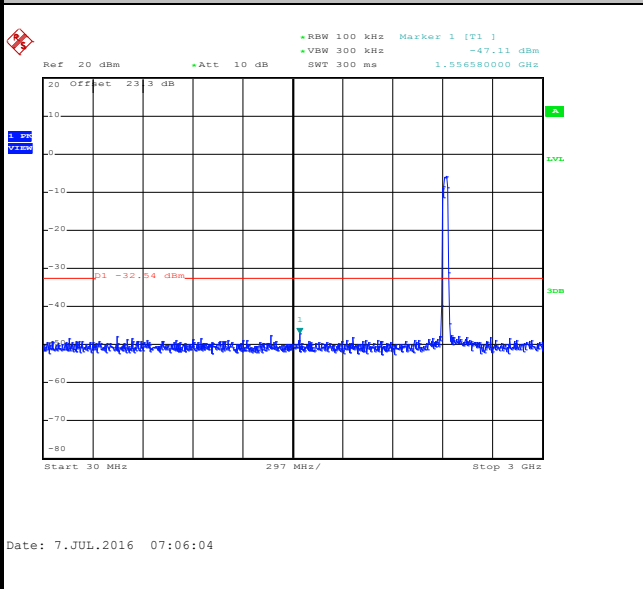

Spurious Emission 2GHz~25GHz

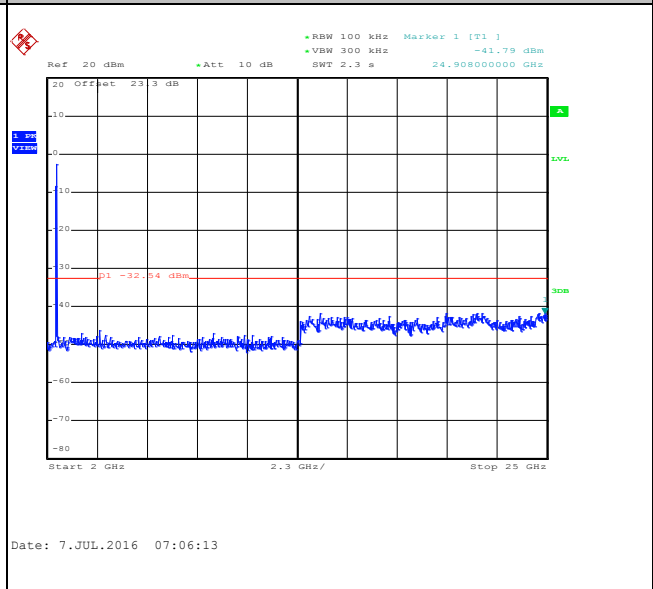



Number of TX :	3	Ant. :	2
Test Mode :	802.11n HT40	Temperature :	21~25°C
Test Band :	2.4GHz Mid	Relative Humidity :	51~54%
Test Channel :	06	Test Engineer :	Derek Hsu

WLAN 802.11n HT40 Channel 06

100kHz PSD reference Level

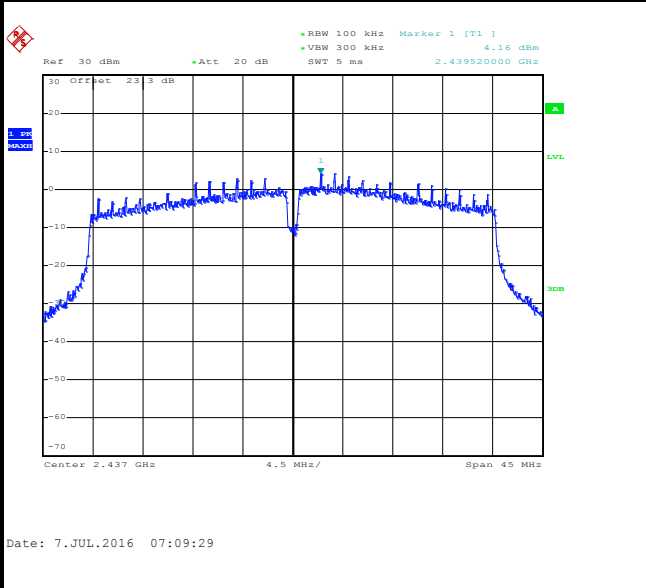

Spurious Emission 30MHz~3GHz

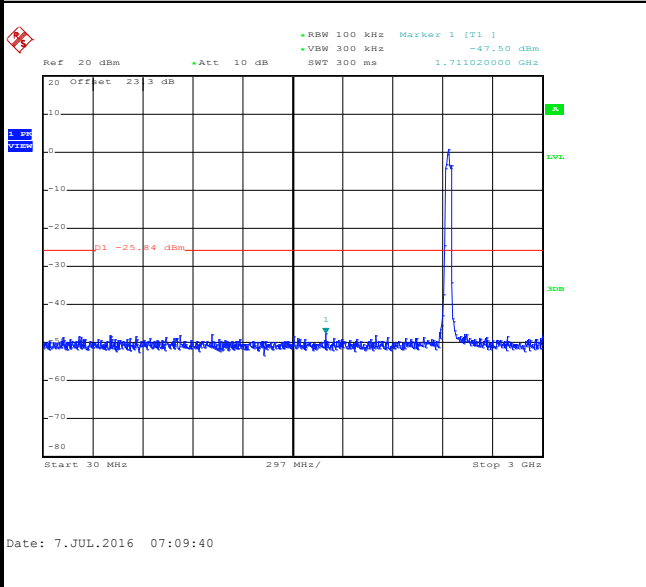

Spurious Emission 2GHz~25GHz

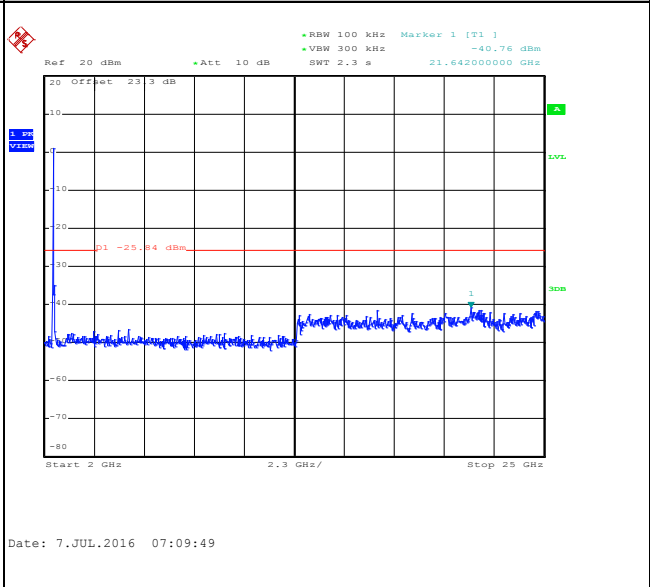



Number of TX :	3	Ant. :	2
Test Mode :	802.11n HT40	Temperature :	21~25°C
Test Band :	2.4GHz High	Relative Humidity :	51~54%
Test Channel :	09	Test Engineer :	Derek Hsu

WLAN 802.11n HT40 Channel 09

100kHz PSD reference Level

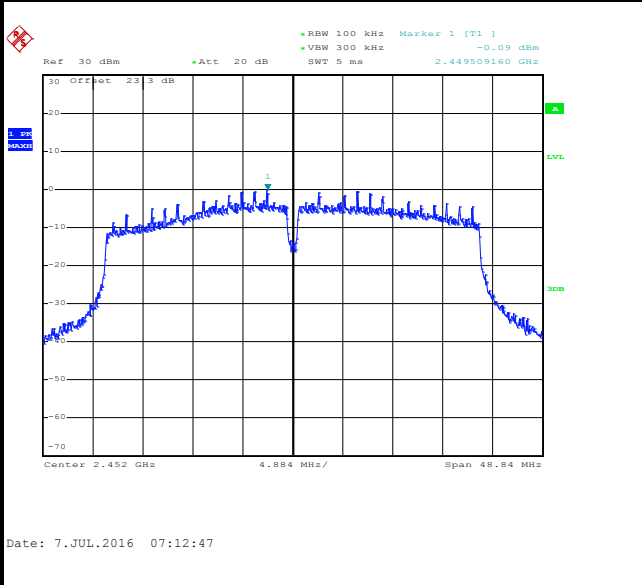

High Channel Plot

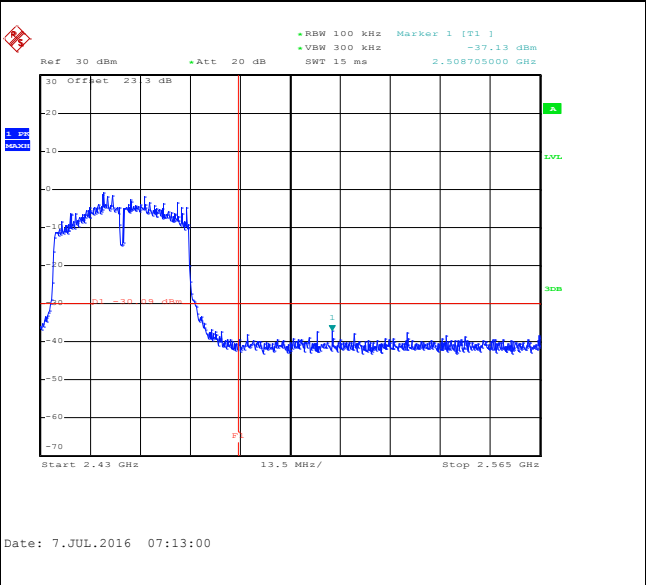

Spurious Emission 30MHz~3GHz

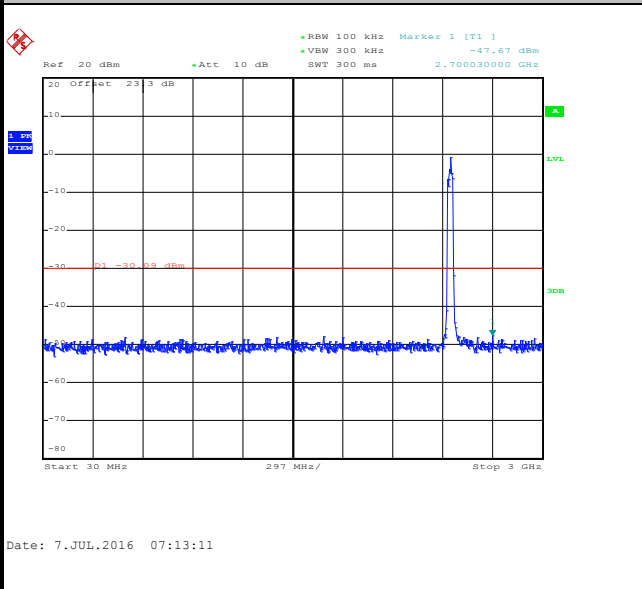

Spurious Emission 2GHz~25GHz

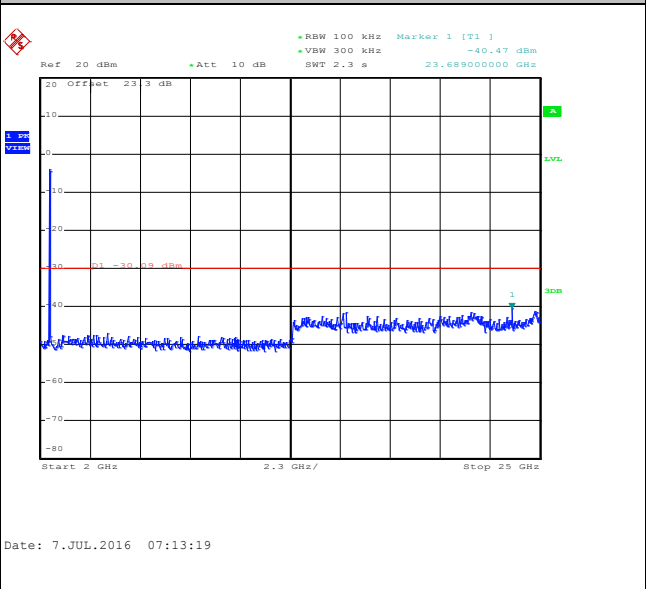



Number of TX = 3, Ant. 3 (Measured)

Number of TX :	3	Ant. :	3
Test Mode :	802.11b	Temperature :	21~25°C
Test Band :	2.4GHz Low	Relative Humidity :	51~54%
Test Channel :	01	Test Engineer :	Derek Hsu

WLAN 802.11b Channel 01

100kHz PSD reference Level

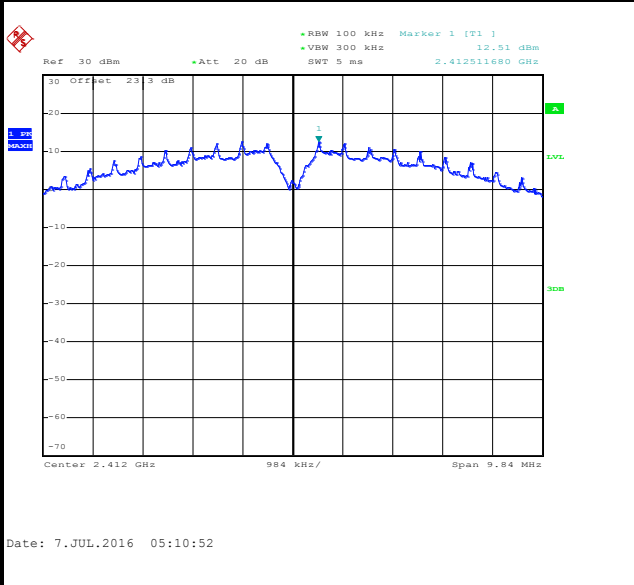

Low Channel Plot

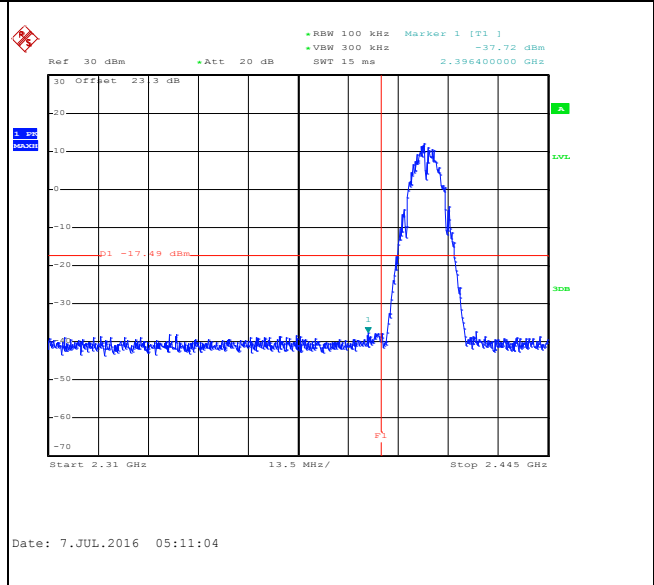

Spurious Emission 30MHz~3GHz

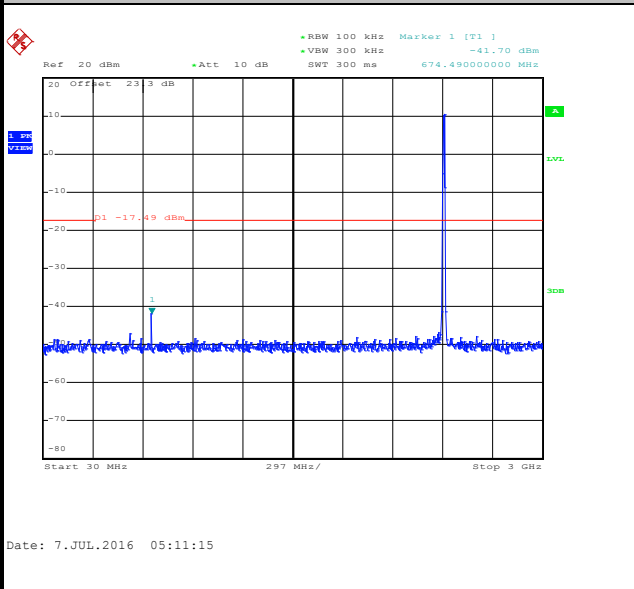

Spurious Emission 2GHz~25GHz

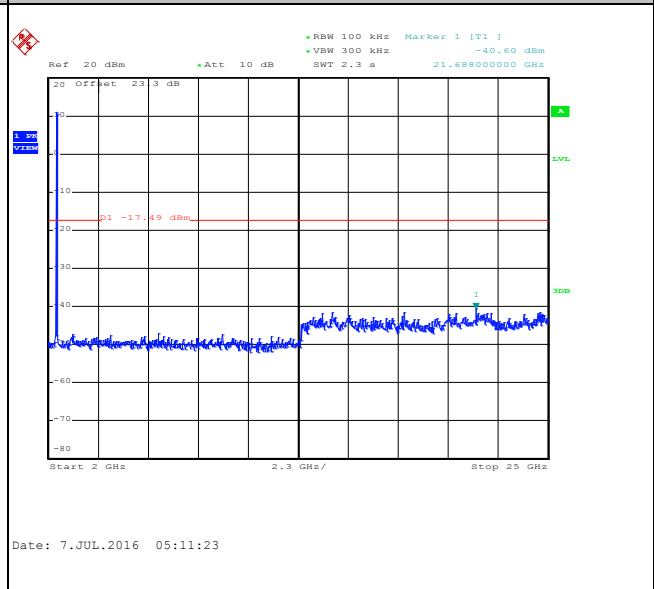



Number of TX :	3	Ant. :	3
Test Mode :	802.11b	Temperature :	21~25°C
Test Band :	2.4GHz Mid	Relative Humidity :	51~54%
Test Channel :	06	Test Engineer :	Derek Hsu

WLAN 802.11b Channel 06

100kHz PSD reference Level

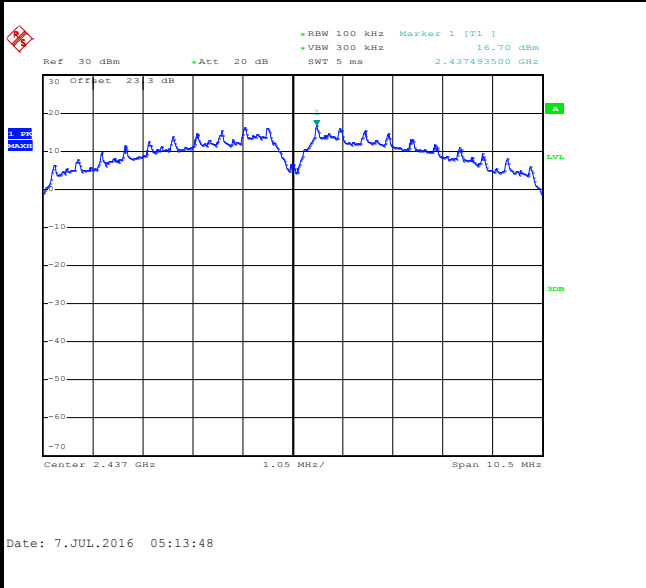

Spurious Emission 30MHz~3GHz

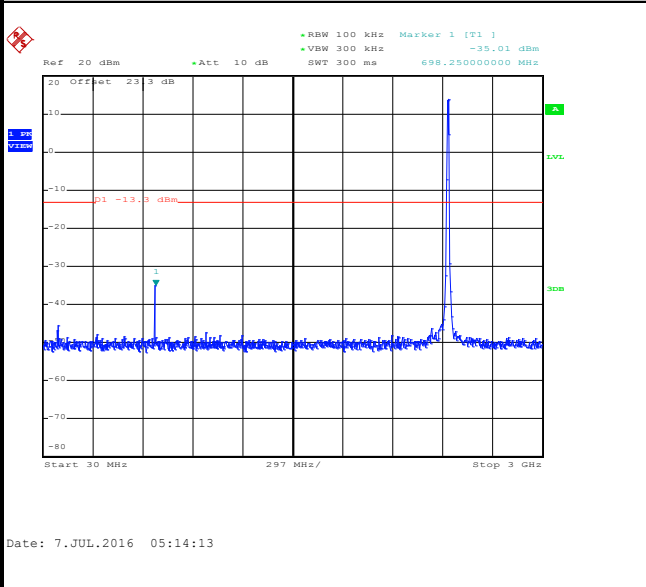

Spurious Emission 2GHz~25GHz

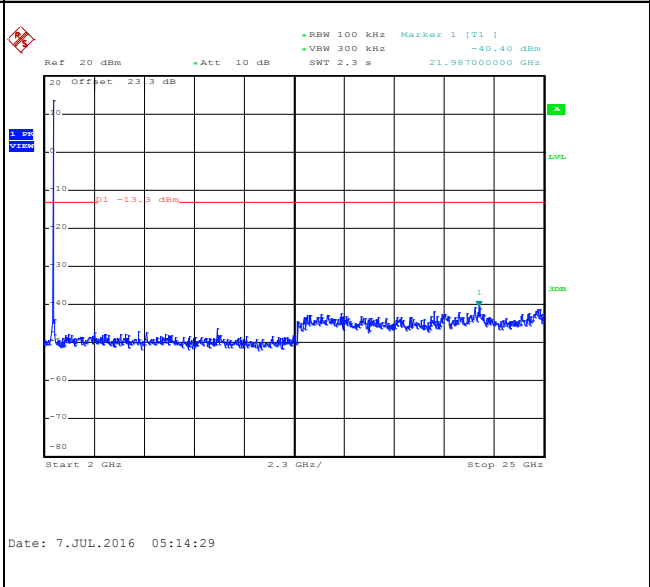



Number of TX :	3	Ant. :	3
Test Mode :	802.11b	Temperature :	21~25°C
Test Band :	2.4GHz High	Relative Humidity :	51~54%
Test Channel :	11	Test Engineer :	Derek Hsu

WLAN 802.11b Channel 11

100kHz PSD reference Level

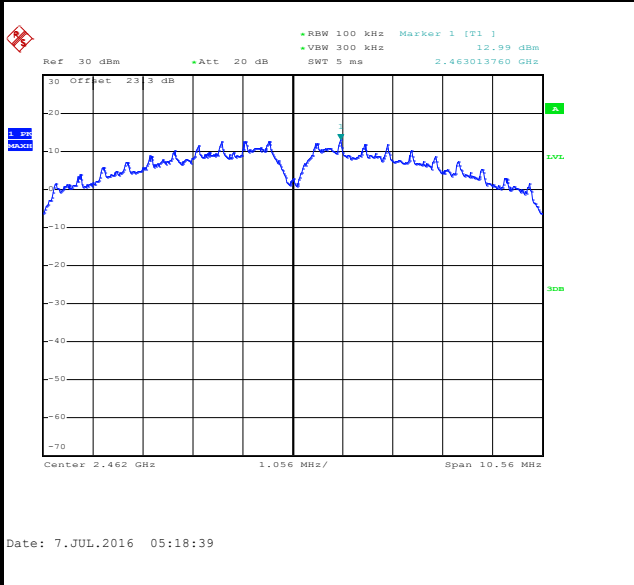

High Channel Plot

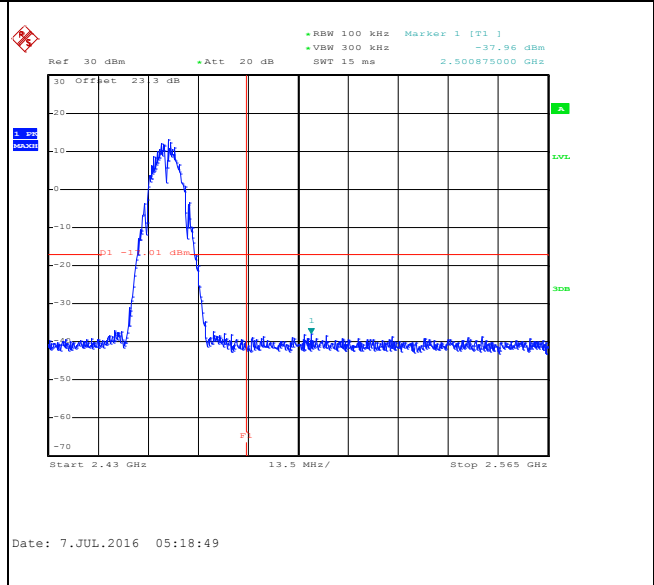

Spurious Emission 30MHz~3GHz

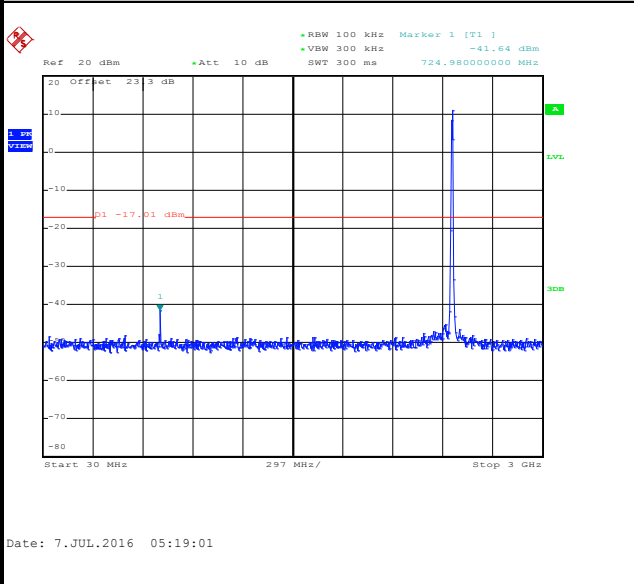

Spurious Emission 2GHz~25GHz

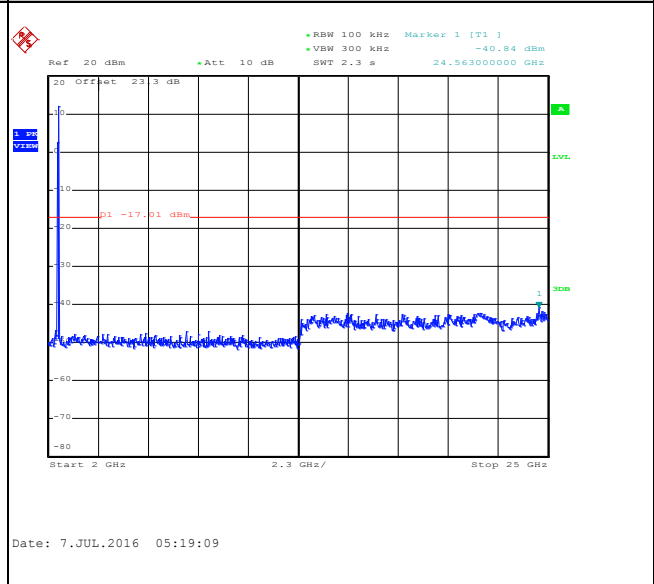



Number of TX :	3	Ant. :	3
Test Mode :	802.11g	Temperature :	21~25°C
Test Band :	2.4GHz Low	Relative Humidity :	51~54%
Test Channel :	01	Test Engineer :	Derek Hsu

WLAN 802.11g Channel 01

100kHz PSD reference Level

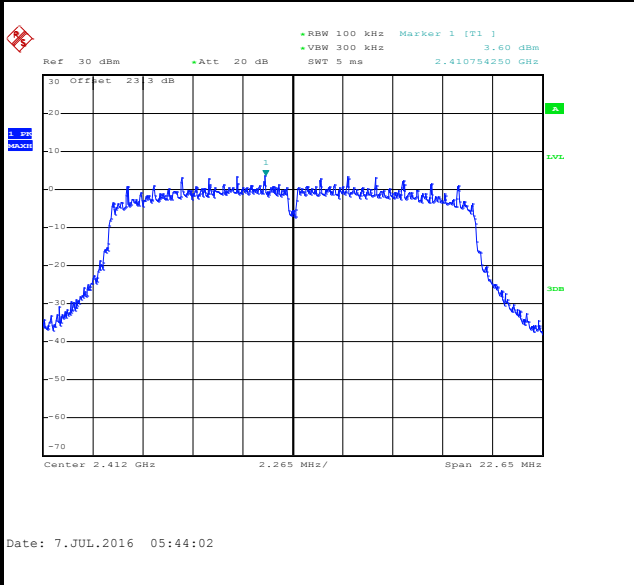

Low Channel Plot

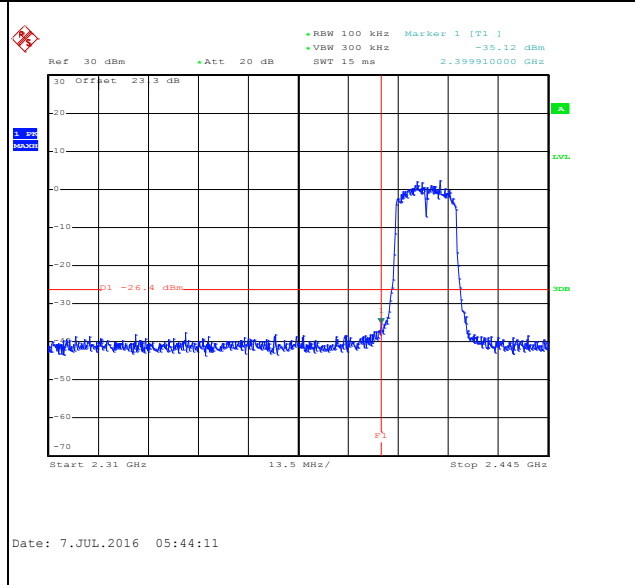

Spurious Emission 30MHz~3GHz

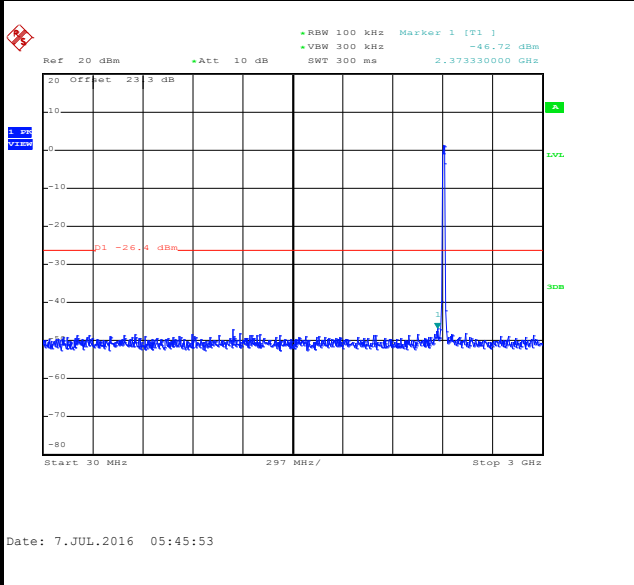

Spurious Emission 2GHz~25GHz

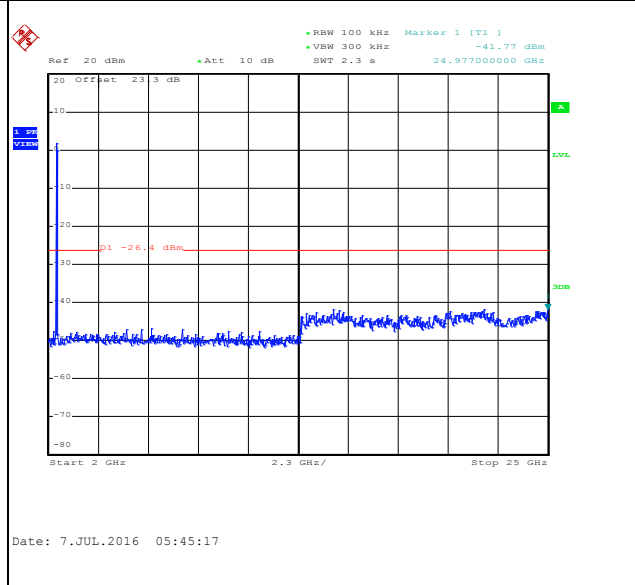



Number of TX :	3	Ant. :	3
Test Mode :	802.11g	Temperature :	21~25°C
Test Band :	2.4GHz Mid	Relative Humidity :	51~54%
Test Channel :	06	Test Engineer :	Derek Hsu

WLAN 802.11g Channel 06

100kHz PSD reference Level

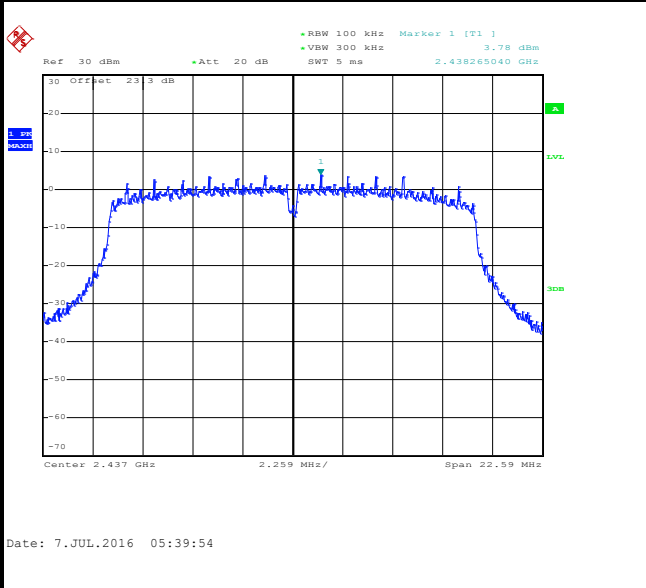

Spurious Emission 30MHz~3GHz

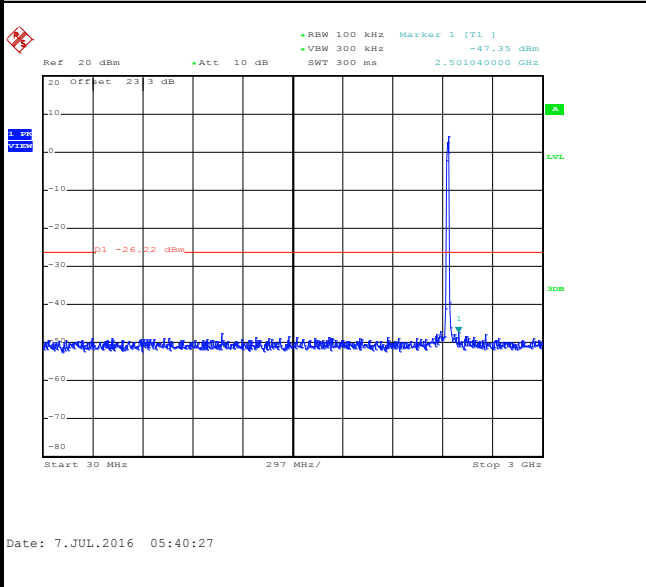

Spurious Emission 2GHz~25GHz

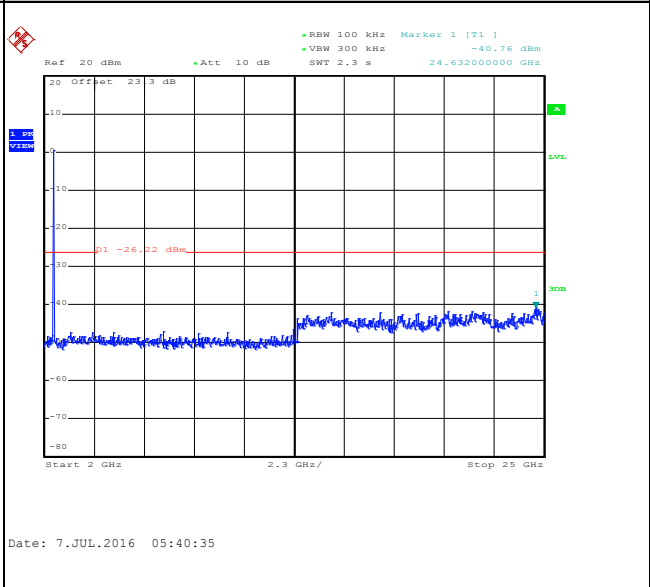



Number of TX :	3	Ant. :	3
Test Mode :	802.11g	Temperature :	21~25°C
Test Band :	2.4GHz High	Relative Humidity :	51~54%
Test Channel :	11	Test Engineer :	Derek Hsu

WLAN 802.11g Channel 11

100kHz PSD reference Level

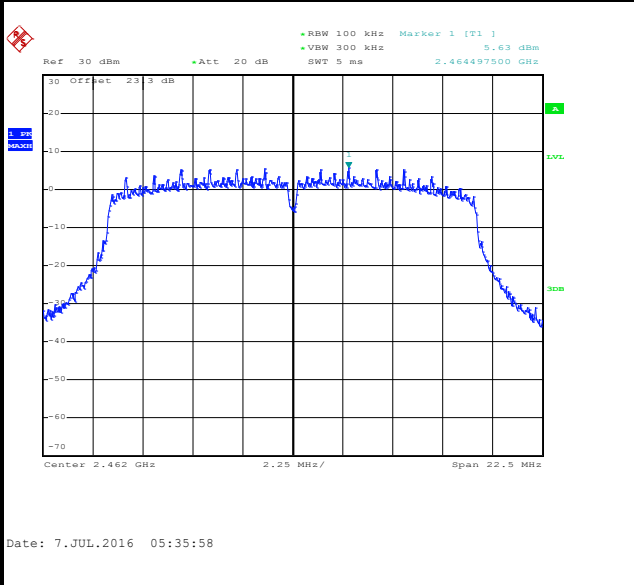

High Channel Plot

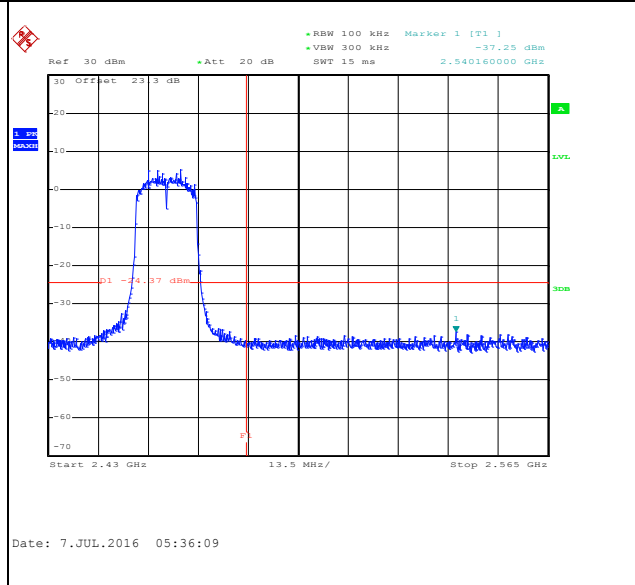

Spurious Emission 30MHz~3GHz

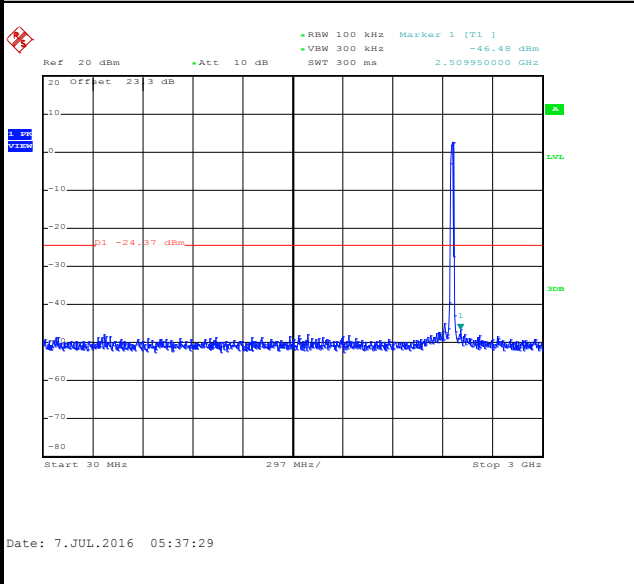

Spurious Emission 2GHz~25GHz

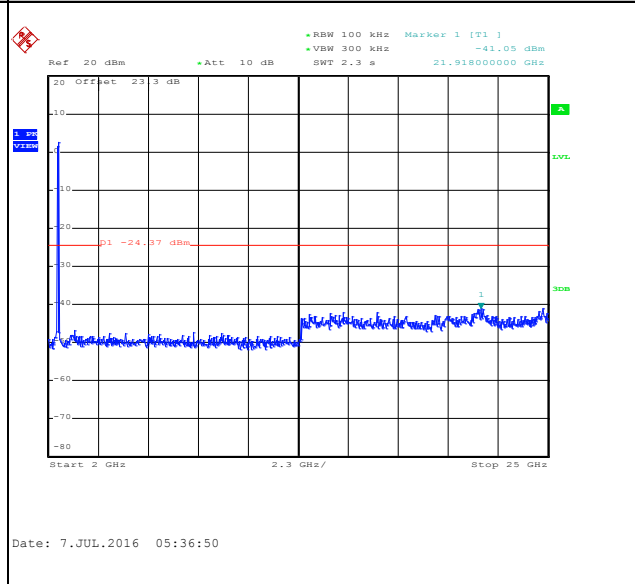



Number of TX :	3	Ant. :	3
Test Mode :	802.11n HT20	Temperature :	21~25°C
Test Band :	2.4GHz Low	Relative Humidity :	51~54%
Test Channel :	01	Test Engineer :	Derek Hsu

WLAN 802.11n HT20 Channel 01

100kHz PSD reference Level

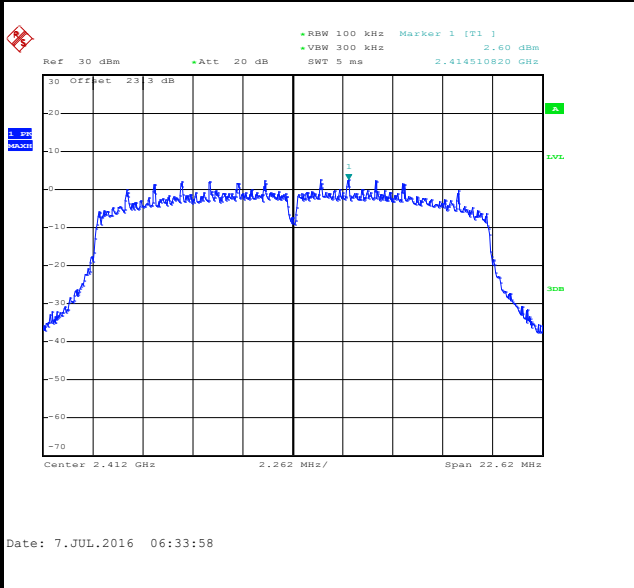

Low Channel Plot

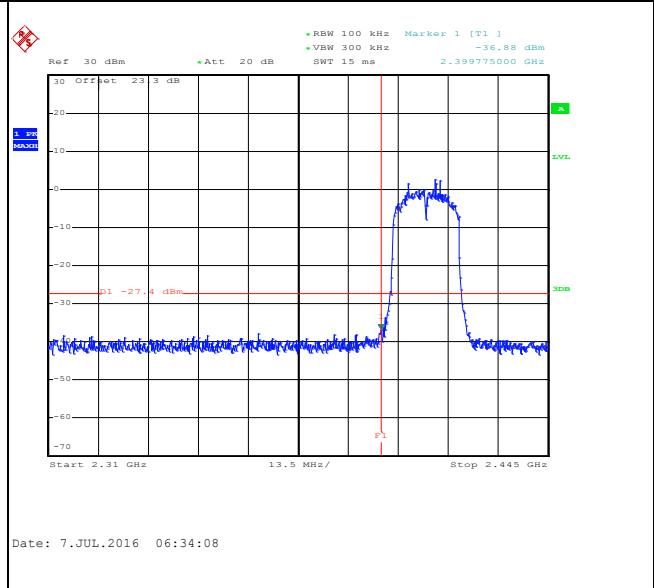

Spurious Emission 30MHz~3GHz

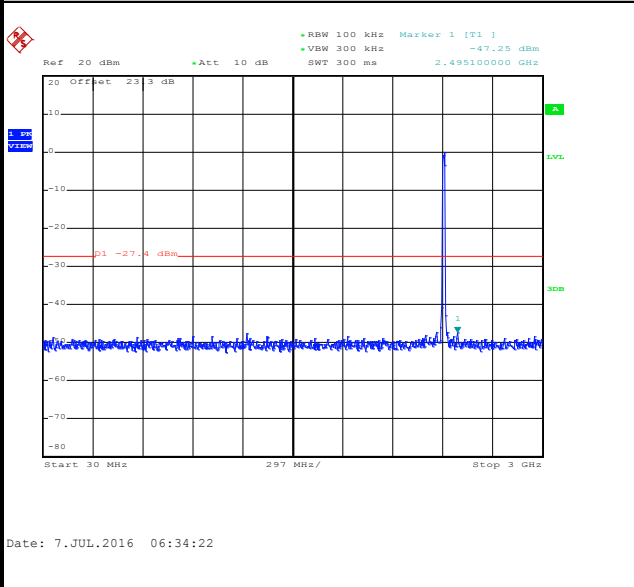

Spurious Emission 2GHz~25GHz

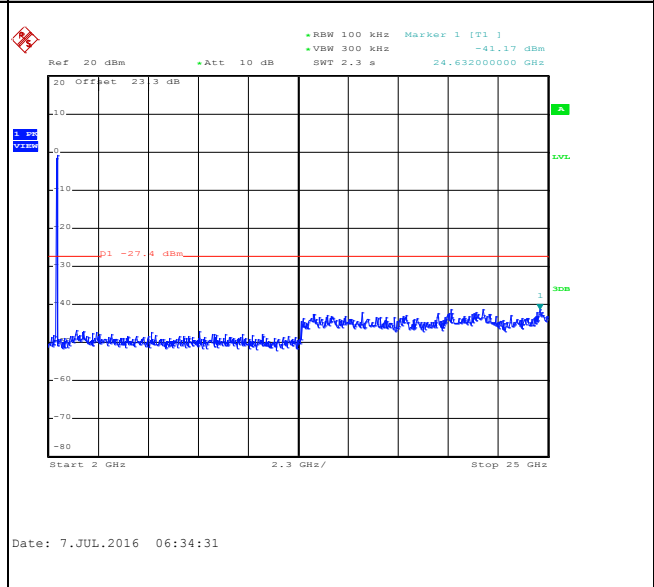



Number of TX :	3	Ant. :	3
Test Mode :	802.11n HT20	Temperature :	21~25°C
Test Band :	2.4GHz Mid	Relative Humidity :	51~54%
Test Channel :	06	Test Engineer :	Derek Hsu

WLAN 802.11n HT20 Channel 06

100kHz PSD reference Level

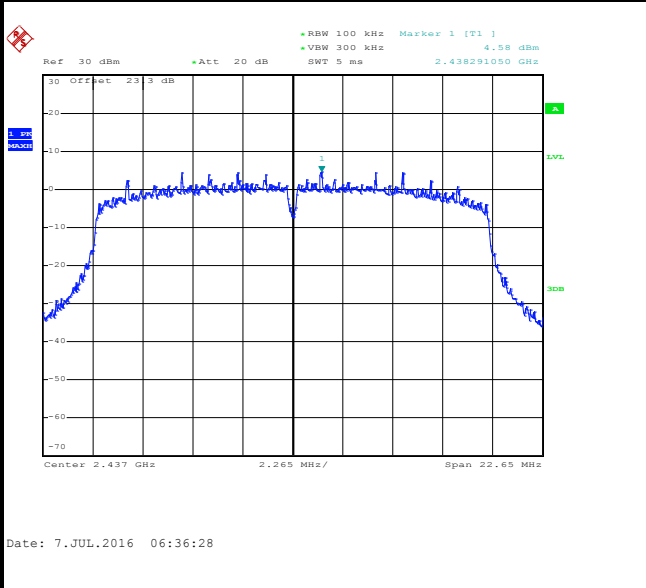

Spurious Emission 30MHz~3GHz

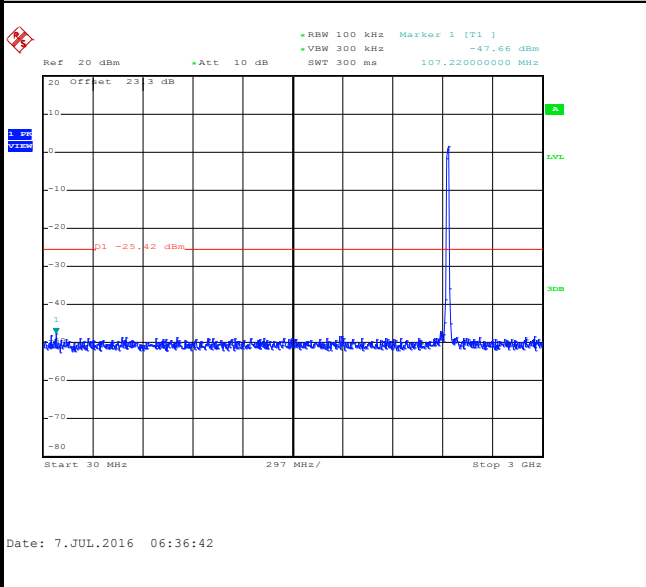

Spurious Emission 2GHz~25GHz

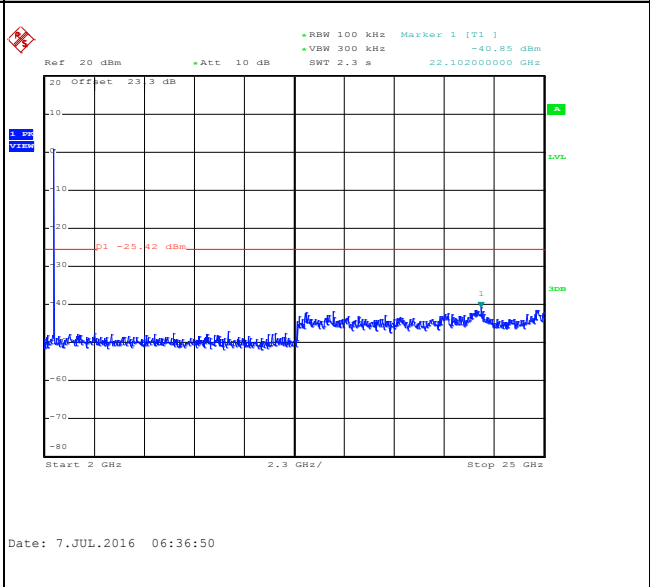



Number of TX :	3	Ant. :	3
Test Mode :	802.11n HT20	Temperature :	21~25°C
Test Band :	2.4GHz High	Relative Humidity :	51~54%
Test Channel :	11	Test Engineer :	Derek Hsu

WLAN 802.11n HT20 Channel 11

100kHz PSD reference Level

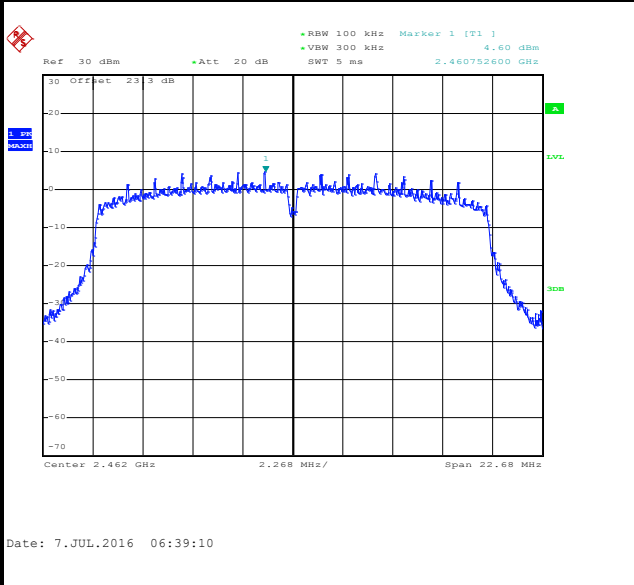

High Channel Plot

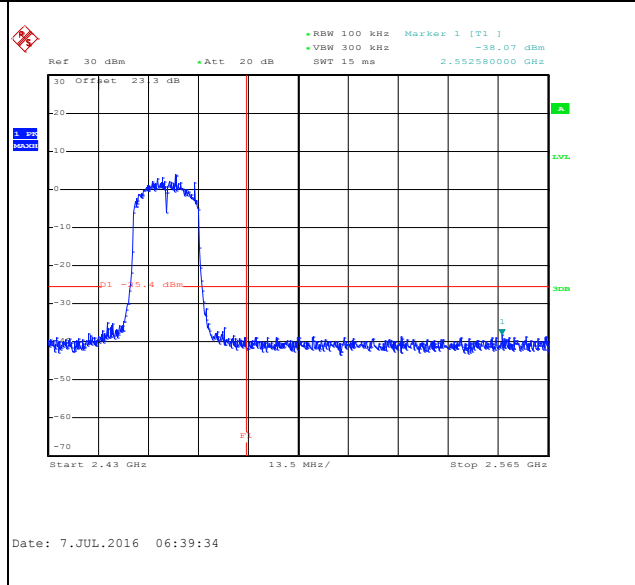

Spurious Emission 30MHz~3GHz

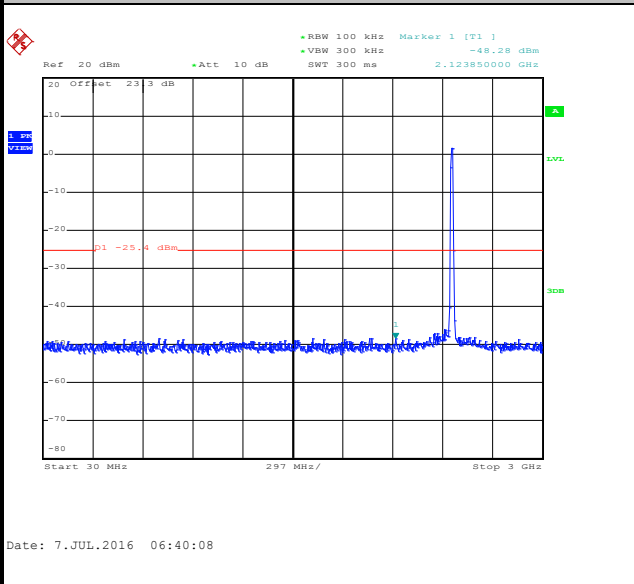

Spurious Emission 2GHz~25GHz

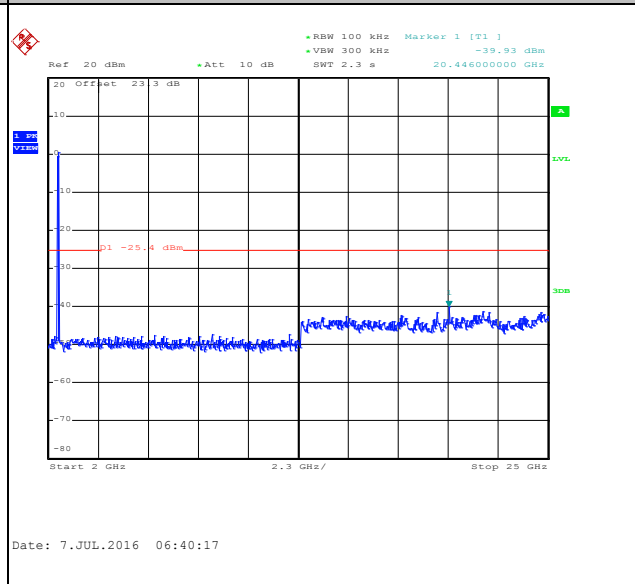



Number of TX :	3	Ant. :	3
Test Mode :	802.11n HT40	Temperature :	21~25°C
Test Band :	2.4GHz Low	Relative Humidity :	51~54%
Test Channel :	03	Test Engineer :	Derek Hsu

WLAN 802.11n HT40 Channel 03

100kHz PSD reference Level

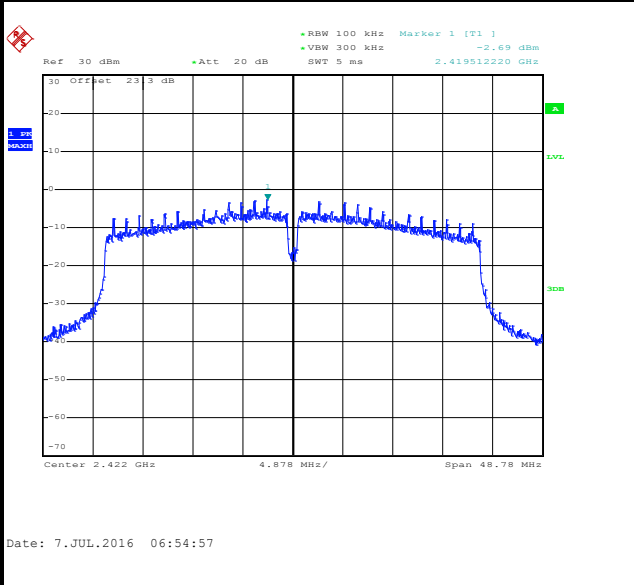

Low Channel Plot

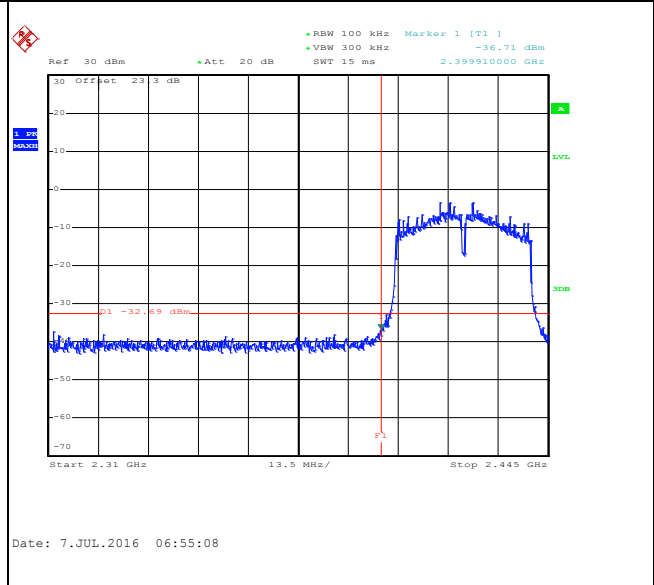

Spurious Emission 30MHz~3GHz

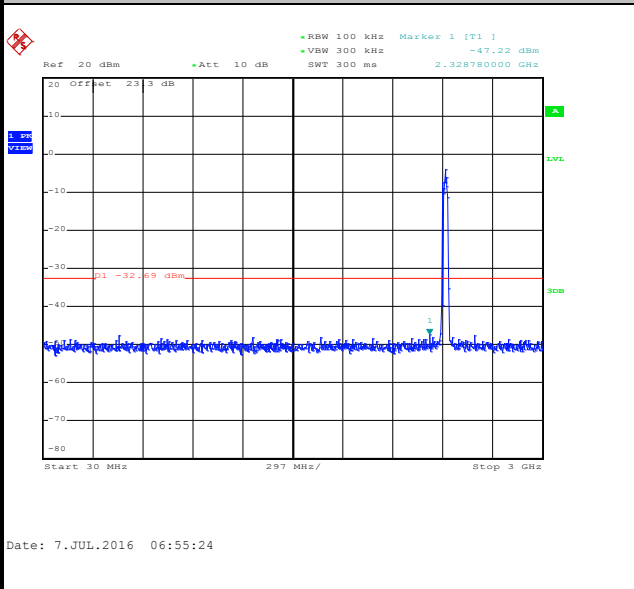

Spurious Emission 2GHz~25GHz

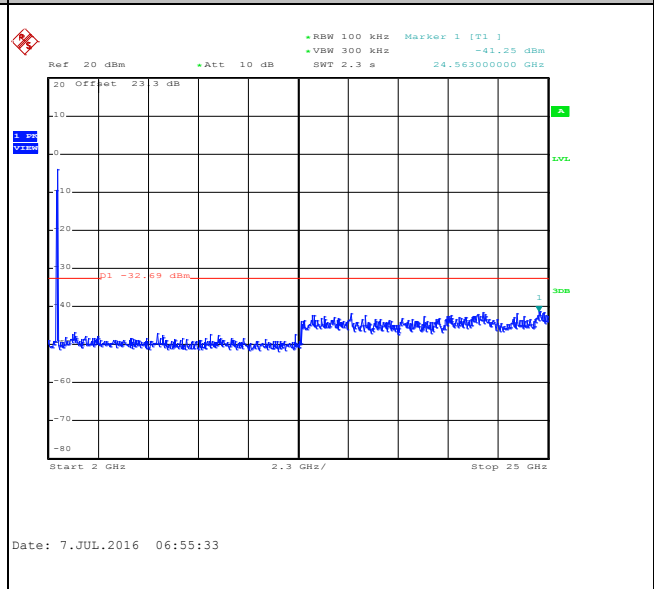



Number of TX :	3	Ant. :	3
Test Mode :	802.11n HT40	Temperature :	21~25°C
Test Band :	2.4GHz Mid	Relative Humidity :	51~54%
Test Channel :	06	Test Engineer :	Derek Hsu

WLAN 802.11n HT40 Channel 06

100kHz PSD reference Level

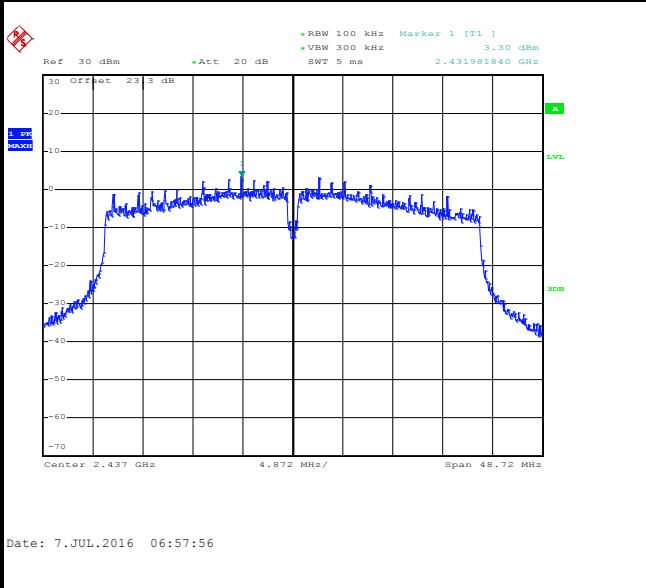

Spurious Emission 30MHz~3GHz

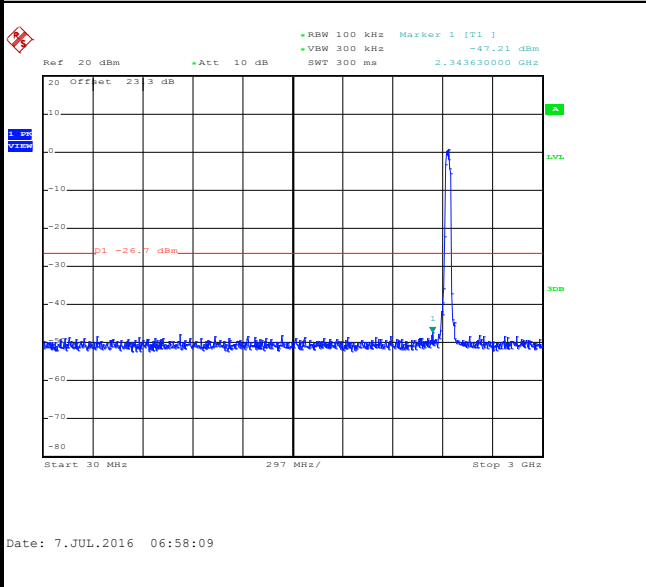

Spurious Emission 2GHz~25GHz

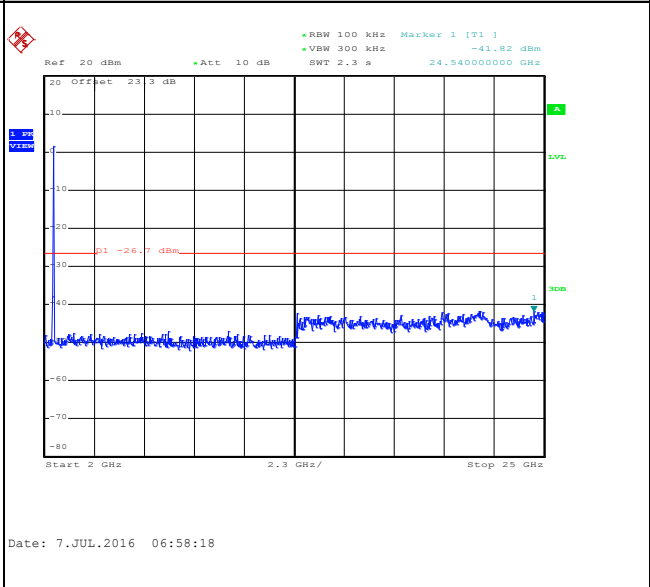



Number of TX :	3	Ant. :	3
Test Mode :	802.11n HT40	Temperature :	21~25°C
Test Band :	2.4GHz High	Relative Humidity :	51~54%
Test Channel :	09	Test Engineer :	Derek Hsu

WLAN 802.11n HT40 Channel 09

100kHz PSD reference Level

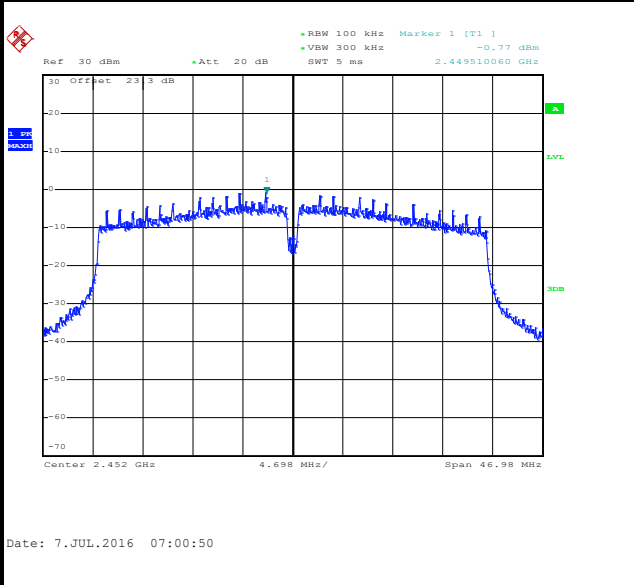

High Channel Plot

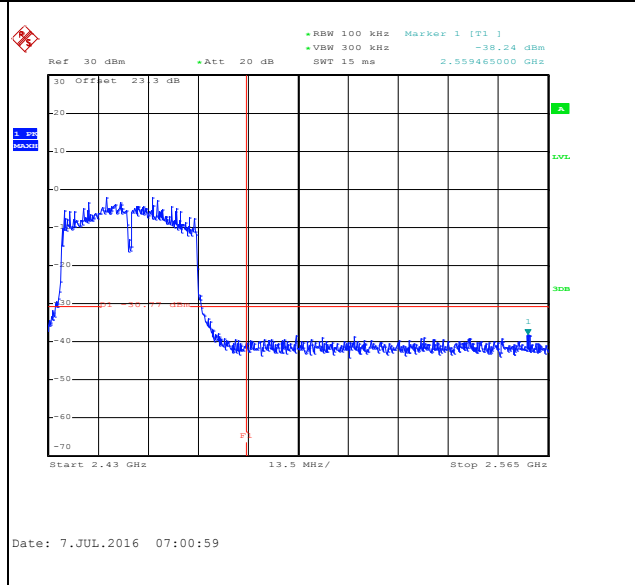

Spurious Emission 30MHz~3GHz

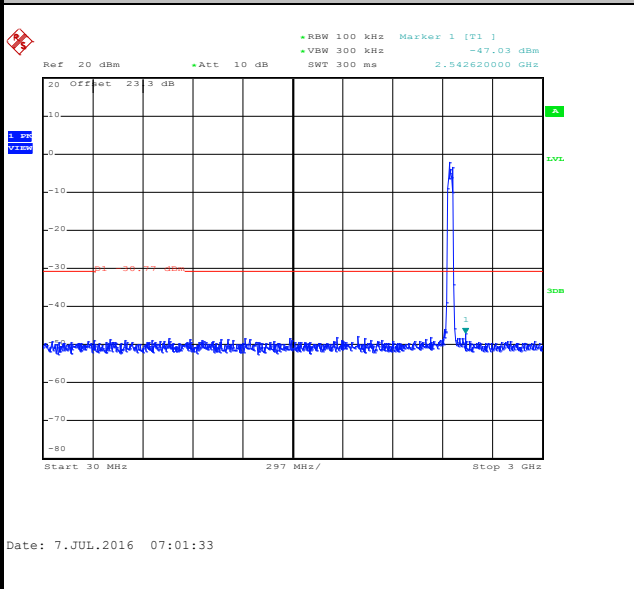

Spurious Emission 2GHz~25GHz

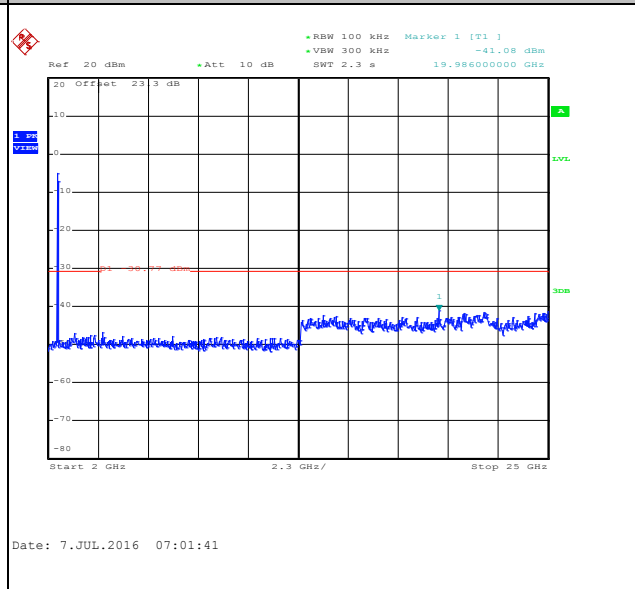



3.5 Radiated Band Edges and Spurious Emission Measurement

3.5.1 Limit of Radiated band edge and Spurious Emission Measurement

In any 100 kHz bandwidth outside the intentional radiator frequency band, all harmonics/spurious must be at least 20 dB below the highest emission level within the authorized band. If the output power of this device was measured by spectrum analyzer, the attenuation under this paragraph shall be 30 dB instead of 20 dB. In addition, radiated emissions which fall in the restricted bands must also comply with the FCC section 15.209 limits as below.

Frequency (MHz)	Field Strength (microvolts/meter)	Measurement Distance (meters)
0.009 – 0.490	2400/F(kHz)	300
0.490 – 1.705	24000/F(kHz)	30
1.705 – 30.0	30	30
30 – 88	100	3
88 – 216	150	3
216 - 960	200	3
Above 960	500	3

3.5.2 Measuring Instruments

The measuring equipment is listed in the section 4 of this test report.



3.5.3 Test Procedure

1. The testing follows FCC KDB Publication No. 558074 D01 DTS Meas. Guidance v03r05.
2. The EUT was arranged to its worst case and then tune the antenna tower (from 1 m to 4 m) and turntable (from 0 degree to 360 degrees) to find the maximum reading. A pre-amp and a high pass filter are used for the test in order to get better signal level.
3. The EUT was placed on a turntable with 0.8 meter for frequency below 1GHz and 1.5 meter for frequency above 1GHz respectively above ground.
4. The EUT was set 3 meters from the interference receiving antenna, which was mounted on the top of a variable height antenna tower.
5. Corrected Reading: Antenna Factor + Cable Loss + Read Level - Preamp Factor = Level
6. For measurement below 1GHz, If the emission level of the EUT measured by the peak detector is 3 dB lower than the applicable limit, the peak emission level will be reported. Otherwise, the emission measurement will be repeated using the quasi-peak detector and reported.
7. Use the following spectrum analyzer settings:
 - (1) Span shall wide enough to fully capture the emission being measured;
 - (2) Set RBW=100 kHz for $f < 1$ GHz; VBW \geq RBW; Sweep = auto; Detector function = peak; Trace = max hold;
 - (3) Set RBW = 1 MHz, VBW= 3MHz for $f \geq 1$ GHz for peak measurement.
For average measurement:
 - VBW = 10 Hz, when duty cycle is no less than 98 percent.
 - VBW $\geq 1/T$, when duty cycle is less than 98 percent where T is the minimum transmission duration over which the transmitter is on and is transmitting at its maximum power control level for the tested mode of operation.

3.5.4 Test Setup

For radiated emissions below 30MHz

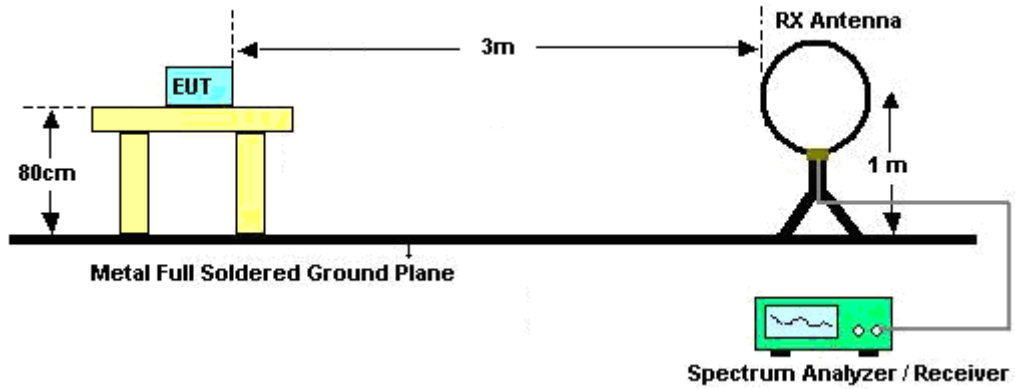

For radiated emissions from 30MHz to 1GHz

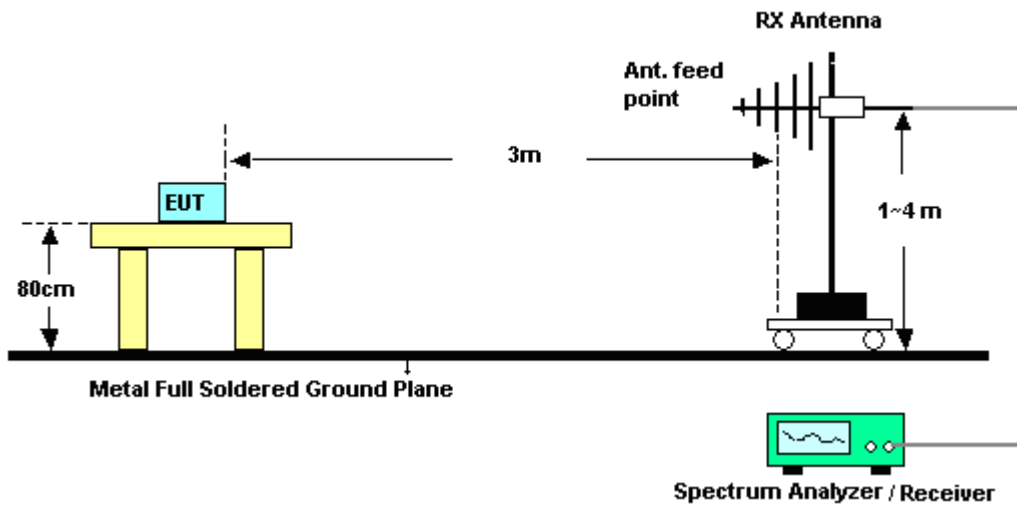

For radiated emissions above 1GHz

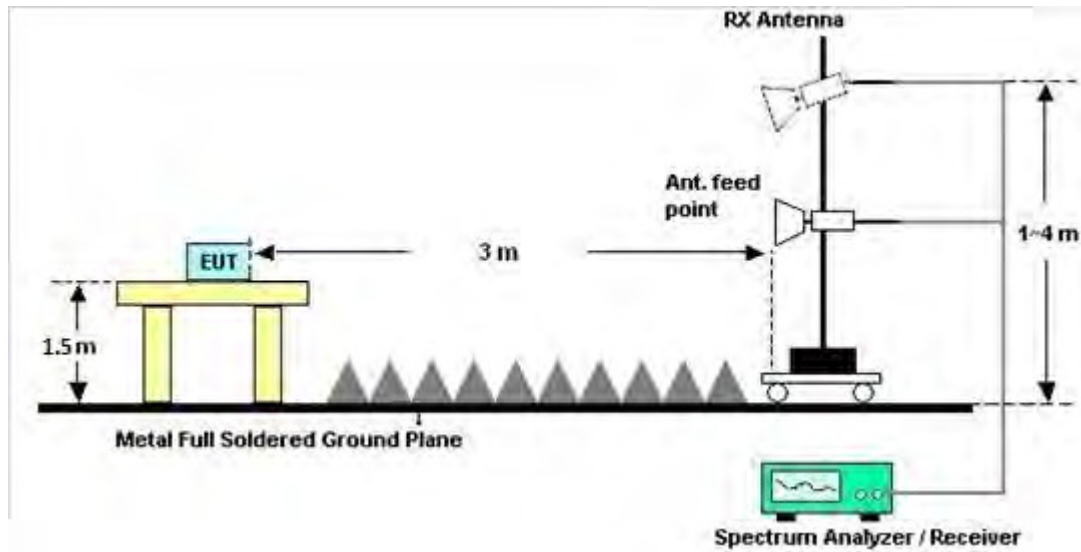

3.5.5 Test Results of Radiated Emissions (9kHz ~ 30MHz)

The low frequency, which started from 9 kHz to 30MHz, was pre-scanned and the result which was 20dB lower than the limit line per 15.31(o) was not reported.

3.5.6 Test Result of Radiated Spurious at Band Edges

Please refer to Appendix B and C of this test report.

3.5.7 Duty Cycle

Please refer to Appendix D.

3.5.8 Test Result of Radiated Spurious Emission (30MHz ~ 10th Harmonic)

Please refer to Appendix B and C.



3.6 AC Conducted Emission Measurement

3.6.1 Limit of AC Conducted Emission

For equipment that is designed to be connected to the public utility (AC) power line, the radio frequency voltage that is conducted back onto the AC power line on any frequency or frequencies within the band 150 kHz to 30 MHz shall not exceed the limits in the following table.

Frequency of Emission (MHz)	Conducted Limit (dB μ V)	
	Quasi-Peak	Average
0.15-0.5	66 to 56*	56 to 46*
0.5-5	56	46
5-30	60	50

*Decreases with the logarithm of the frequency.

3.6.2 Measuring Instruments

The measuring equipment is listed in the section 4 of this test report.

3.6.3 Test Procedures

1. The EUT was placed 0.4 meter from the conducting wall of the shielding room, and it was kept at least 80 centimeters from any other grounded conducting surface.
2. Connect EUT to the power mains through a line impedance stabilization network (LISN).
3. All the support units are connecting to the other LISN.
4. The LISN provides 50 ohm coupling impedance for the measuring instrument.
5. The FCC states that a 50 ohm, 50 microhenry LISN should be used.
6. Both sides of AC line were checked for maximum conducted interference.
7. The frequency range from 150 kHz to 30 MHz was searched.
8. Set the test-receiver system to Peak Detect Function and specified bandwidth (IF bandwidth = 9kHz) with Maximum Hold Mode.

3.6.4 Test Setup

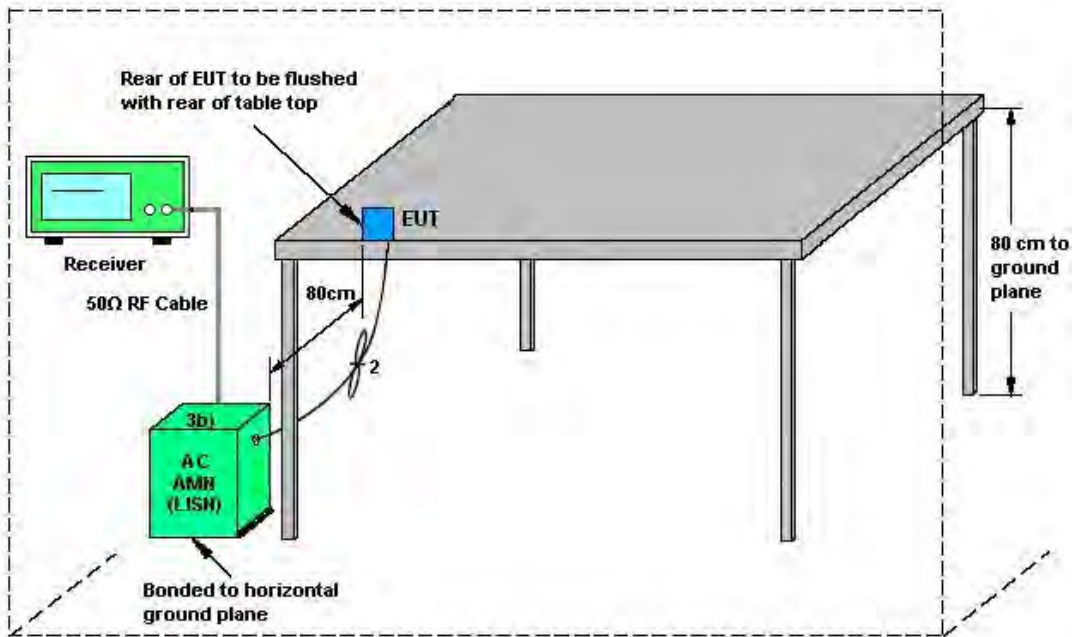

AMN = Artificial mains network (LISN)
AE = Associated equipment
EUT = Equipment under test
ISN = Impedance stabilization network



3.6.5 Test Result of AC Conducted Emission

Test Mode :	Mode 1	Temperature :	22~23°C
Test Engineer :	Arthur Hsieh	Relative Humidity :	50~51%
Test Voltage :	120Vac / 60Hz	Phase :	Line
Function Type :	WLAN (2.4GHz) Link 802.11n HT20 MCS0 + Bluetooth Link + WAN Link + LAN Link + USB Link + Adapter 1		

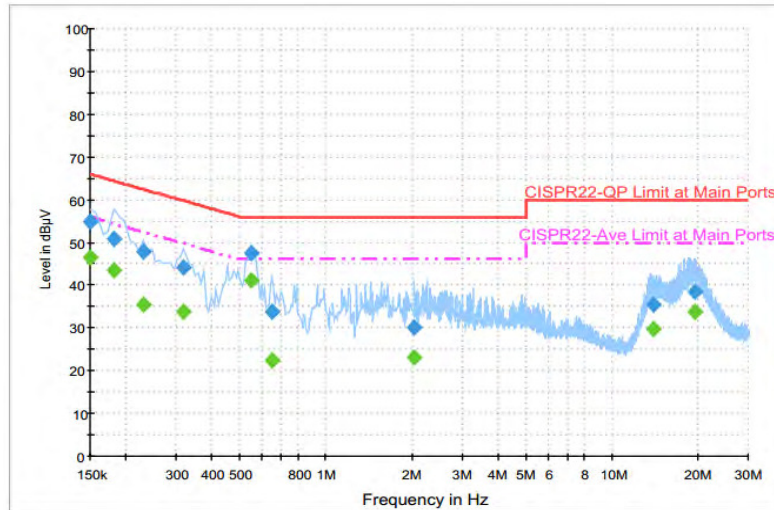

Final Result : Quasi-Peak

Frequency (MHz)	Quasi-Peak (dBµV)	Filter	Line	Corr. (dB)	Margin (dB)	Limit (dBµV)
0.150000	54.9	Off	L1	19.6	11.1	66.0
0.182000	51.0	Off	L1	19.6	13.4	64.4
0.230000	47.7	Off	L1	19.6	14.7	62.4
0.318000	44.3	Off	L1	19.6	15.5	59.8
0.550000	47.6	Off	L1	19.6	8.4	56.0
0.646000	33.9	Off	L1	19.6	22.1	56.0
2.046000	30.0	Off	L1	19.6	26.0	56.0
13.926000	35.4	Off	L1	20.3	24.6	60.0
19.462000	38.5	Off	L1	20.7	21.5	60.0

Final Result : Average

Frequency (MHz)	Average (dBµV)	Filter	Line	Corr. (dB)	Margin (dB)	Limit (dBµV)
0.150000	46.5	Off	L1	19.6	9.5	56.0
0.182000	43.5	Off	L1	19.6	10.9	54.4
0.230000	35.3	Off	L1	19.6	17.1	52.4
0.318000	33.7	Off	L1	19.6	16.1	49.8
0.550000	41.2	Off	L1	19.6	4.8	46.0
0.646000	22.6	Off	L1	19.6	23.4	46.0
2.046000	23.1	Off	L1	19.6	22.9	46.0
13.926000	29.8	Off	L1	20.3	20.2	50.0
19.462000	33.8	Off	L1	20.7	16.2	50.0



Test Mode :	Mode 1	Temperature :	22~23°C
Test Engineer :	Arthur Hsieh	Relative Humidity :	50~51%
Test Voltage :	120Vac / 60Hz	Phase :	Neutral
Function Type :	WLAN (2.4GHz) Link 802.11n HT20 MCS0 + Bluetooth Link + WAN Link + LAN Link + USB Link + Adapter 1		

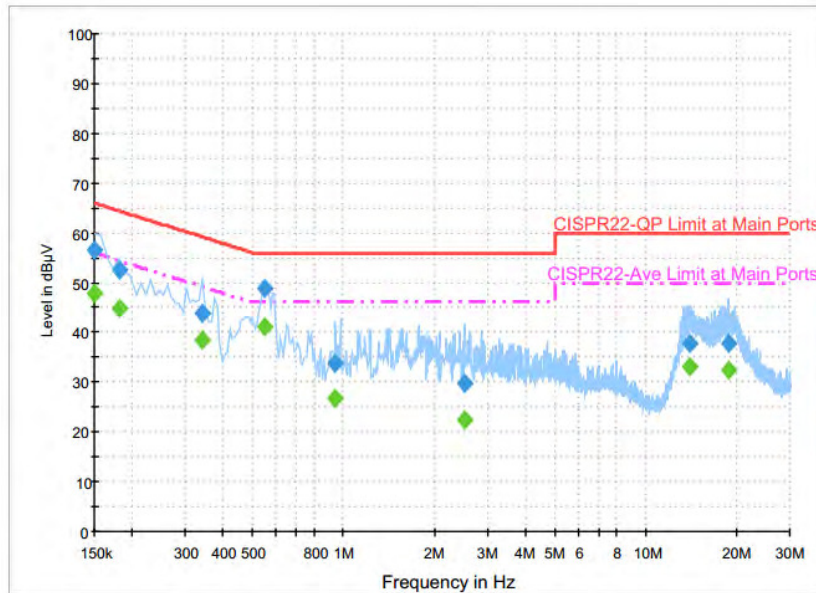

Final Result : Quasi-Peak

Frequency (MHz)	Quasi-Peak (dBµV)	Filter	Line	Corr. (dB)	Margin (dB)	Limit (dBµV)
0.150000	56.5	Off	N	19.6	9.5	66.0
0.182000	52.6	Off	N	19.6	11.8	64.4
0.342000	43.9	Off	N	19.6	15.3	59.2
0.550000	48.7	Off	N	19.6	7.3	56.0
0.942000	33.8	Off	N	19.6	22.2	56.0
2.510000	29.7	Off	N	19.7	26.3	56.0
13.974000	37.8	Off	N	20.4	22.2	60.0
18.878000	37.9	Off	N	20.7	22.1	60.0

Final Result : Average

Frequency (MHz)	Average (dBµV)	Filter	Line	Corr. (dB)	Margin (dB)	Limit (dBµV)
0.150000	47.7	Off	N	19.6	8.3	56.0
0.182000	44.9	Off	N	19.6	9.5	54.4
0.342000	38.5	Off	N	19.6	10.7	49.2
0.550000	41.3	Off	N	19.6	4.7	46.0
0.942000	26.6	Off	N	19.6	19.4	46.0
2.510000	22.5	Off	N	19.7	23.5	46.0
13.974000	33.3	Off	N	20.4	16.7	50.0
18.878000	32.5	Off	N	20.7	17.5	50.0



3.7 Antenna Requirements

3.7.1 Standard Applicable

If directional gain of transmitting Antennas is greater than 6dBi, the power shall be reduced by the same level in dB comparing to gain minus 6dBi. For the fixed point-to-point operation, the power shall be reduced by one dB for every 3 dB that the directional gain of the Antenna exceeds 6 dBi. The use of a permanently attached Antenna or of an Antenna that uses a unique coupling to the intentional radiator shall be considered sufficient to comply with the FCC rule.

3.7.2 Antenna Anti-Replacement Construction

An embedded-in antenna design is used.



3.7.3 Antenna Gain

FCC KDB 662911 D01 Multiple Transmitter Output v02r01

For CDD transmissions, directional gain is calculated as

Directional gain = G_{ANT} + Array Gain, where Array Gain is as follows.

For power spectral density (PSD) measurements on all devices,

Array Gain = $10 \log(N_{ANT}/N_{SS}=1)$ dB.

For power measurements on IEEE 802.11 devices,

Array Gain = 0 dB (i.e., no array gain) for $N_{ANT} \leq 4$.

Directional gain may be calculated by using the formulas applicable to equal gain antennas with G_{ANT} set equal to the gain of the antenna having the highest gain;

The EUT supports CDD mode.

For power, the directional gain G_{ANT} is set equal to the antenna having the highest gain, i.e., F)2)f)i).

For PSD, the directional gain calculation is following F)2)f)ii) of KDB 662911 D01 v02r01.

The power and PSD limit should be modified if the directional gain of EUT is over 6 dBi,

The directional gain "DG" is calculated as following table.

				DG	DG	Power	PSD
				for	for	Limit	Limit
	Ant. 1	Ant. 2	Ant. 3	Power	PSD	Reduction	Reduction
	(dBi)	(dBi)	(dBi)	(dBi)	(dBi)	(dB)	(dB)
2.4 GHz	3.50	3.74	3.39	3.74	8.32	0.00	2.32

$Power\ Limit\ Reduction = DG(Power) - 6dBi, (min = 0)$

$PSD\ Limit\ Reduction = DG(PSD) - 6dBi, (min = 0)$



4 List of Measuring Equipment

Instrument	Manufacturer	Model No.	Serial No.	Characteristics	Calibration Date	Test Date	Due Date	Remark
Power Meter	Anritsu	ML2495A	1132003	300MHz~40GHz	Aug. 12, 2015	Jun. 29, 2016 ~ Jul. 07, 2016	Aug. 11, 2016	Conducted (TH02-HY)
Power Sensor	Anritsu	MA2411B	1126017	300MHz~40GHz	Aug. 12, 2015	Jun. 29, 2016 ~ Jul. 07, 2016	Aug. 11, 2016	Conducted (TH02-HY)
Signal Analyzer	Rohde & Schwarz	FSV40	101397	10Hz~40GHz	Sep. 11, 2015	Jun. 29, 2016 ~ Jul. 07, 2016	Sep. 10, 2016	Conducted (TH02-HY)
Spectrum Analyzer	Rohde & Schwarz	FSP40	100057	9kHz~40GHz	Nov. 23, 2015	Jun. 29, 2016 ~ Jul. 07, 2016	Nov. 22, 2016	Conducted (TH02-HY)
AC Power Source	ChainTek	APC-1000W	N/A	N/A	N/A	Jun. 24, 2016	N/A	Conduction (CO05-HY)
EMI Test Receiver	Rohde & Schwarz	ESCI 7	100724	9kHz~7GHz	Aug. 26, 2015	Jun. 24, 2016	Aug. 25, 2016	Conduction (CO05-HY)
LISN	Rohde & Schwarz	ENV216	100080	9kHz~30MHz	Dec. 02, 2015	Jun. 24, 2016	Dec. 01, 2016	Conduction (CO05-HY)
LISN	Rohde & Schwarz	ENV216	100081	9kHz~30MHz	Dec. 14, 2015	Jun. 24, 2016	Dec. 13, 2016	Conduction (CO05-HY)
Loop Antenna	Rohde & Schwarz	HFH2-Z2	100315	9 kHz~30 MHz	Sep. 02, 2015	Jun. 22, 2016 ~ Jul. 13, 2016	Sep. 01, 2016	Radiation (03CH10-HY)
Amplifier	SONOMA	310N	187311	9kHz~1GHz	Nov. 16, 2015	Jun. 22, 2016 ~ Jul. 13, 2016	Nov. 15, 2016	Radiation (03CH10-HY)
Bilog Antenna	TESEQ	CBL 6111D	35413	30MHz~1GHz	Jan. 13, 2016	Jun. 22, 2016 ~ Jul. 13, 2016	Jan. 12, 2017	Radiation (03CH10-HY)
Horn Antenna	SCHWARZBECK	BBHA 9120 D	9120D-1325	1GHz ~ 18GHz	Sep. 30, 2015	Jun. 22, 2016 ~ Jul. 13, 2016	Sep. 29, 2016	Radiation (03CH10-HY)
Preamplifier	Keysight	83017A	MY53270078	1GHz~26.5GHz	Nov. 13, 2015	Jun. 22, 2016 ~ Jul. 13, 2016	Nov. 12, 2016	Radiation (03CH10-HY)
Preamplifier	MITEQ	AMF-7D-0010 1800-30-10P	1902246	1GHz~18GHz	Nov. 16, 2015	Jun. 22, 2016 ~ Jul. 13, 2016	Nov. 15, 2016	Radiation (03CH10-HY)
Spectrum Analyzer	Keysight	N9010A	MY54200485	10Hz ~ 44GHz	Oct. 15, 2015	Jun. 22, 2016 ~ Jul. 13, 2016	Oct. 14, 2016	Radiation (03CH10-HY)
Controller	EMEC	EM 1000	N/A	Control Turn table & Ant Mast	N/A	Jun. 22, 2016 ~ Jul. 13, 2016	N/A	Radiation (03CH10-HY)
Antenna Mast	EMEC	AM-BS-4500-B	N/A	1~4m	N/A	Jun. 22, 2016 ~ Jul. 13, 2016	N/A	Radiation (03CH10-HY)
Turn Table	EMEC	TT 2200	N/A	0~360 Degree	N/A	Jun. 22, 2016 ~ Jul. 13, 2016	N/A	Radiation (03CH10-HY)
EMI Test Receiver	Keysight	N9038A(MXE)	MY55420170	N/A	Mar. 10, 2016	Jun. 22, 2016 ~ Jul. 13, 2016	Mar. 09, 2017	Radiation (03CH10-HY)
Preamplifier	MITEQ	JS44-180040 00-33-8P	1840917	18GHz ~ 40GHz	Jun. 14, 2016	Jun. 22, 2016 ~ Jul. 13, 2016	Jun. 13, 2017	Radiation (03CH10-HY)
SHF-EHF Horn Antenna	SCHWARZBECK	BBHA 9170	BBHA9170584	18GHz- 40GHz	Nov. 02, 2015	Jun. 22, 2016 ~ Jul. 13, 2016	Nov. 01, 2016	Radiation (03CH10-HY)



5 Uncertainty of Evaluation

Uncertainty of Conducted Emission Measurement (150kHz ~ 30MHz)

Measuring Uncertainty for a Level of Confidence of 95% ($U = 2Uc(y)$)	2.26
---	------

Uncertainty of Radiated Emission Measurement (30 MHz ~ 1000 MHz)

Measuring Uncertainty for a Level of Confidence of 95% ($U = 2Uc(y)$)	5.50
---	------

Uncertainty of Radiated Emission Measurement (1GHz ~ 40GHz)

Measuring Uncertainty for a Level of Confidence of 95% ($U = 2Uc(y)$)	4.90
---	------



Appendix A. Conducted Test Results

Test Engineer:	Derek Hsu	Temperature:	21~25	°C
Test Date:	2016/6/29 ~ 2016/07/07	Relative Humidity:	51~54	%

TEST RESULTS DATA
6dB and 99% Occupied Bandwidth

2.4GHz Band												
Mod.	Data Rate	NTX	CH.	Freq. (MHz)	99% Occupied BW (MHz)			6dB BW (MHz)			6dB BW Limit (MHz)	Pass/Fail
					Ant 1	Ant 2	Ant 3	Ant 1	Ant 2	Ant 3		
11b	1Mbps	3	1	2412	11.30	11.40	11.45	6.06	6.48	6.56	0.50	Pass
11b	1Mbps	3	6	2437	11.65	11.70	11.80	6.56	7.00	7.00	0.50	Pass
11b	1Mbps	3	11	2462	11.45	11.35	11.40	7.02	7.02	7.04	0.50	Pass
11g	6Mbps	3	1	2412	16.70	16.70	16.70	15.30	15.08	15.10	0.50	Pass
11g	6Mbps	3	6	2437	16.70	16.70	16.70	15.08	15.08	15.06	0.50	Pass
11g	6Mbps	3	11	2462	16.80	16.80	16.70	15.06	15.04	15.00	0.50	Pass
HT20	MCS0	3	1	2412	17.70	17.70	17.75	15.10	15.08	15.08	0.50	Pass
HT20	MCS0	3	6	2437	17.65	17.80	17.75	15.12	15.04	15.10	0.50	Pass
HT20	MCS0	3	11	2462	17.80	17.80	17.70	15.46	15.12	15.12	0.50	Pass
HT40	MCS0	3	3	2422	35.80	36.00	35.90	33.76	32.56	32.52	0.50	Pass
HT40	MCS0	3	6	2437	35.90	36.00	36.10	32.52	30.00	32.48	0.50	Pass
HT40	MCS0	3	9	2452	35.90	35.80	35.90	33.80	32.56	31.32	0.50	Pass

TEST RESULTS DATA
Peak Output Power
(Reporting Only)

2.4GHz Band											
Mod.	Data Rate	NTX	CH.	Freq. (MHz)	Peak Conducted Power (dBm)				DG (dBi)		
					Ant 1	Ant 2	Ant 3	SUM	Ant 1	Ant 2	Ant 3
11b	1Mbps	3	1	2412	24.53	23.45	23.40	28.60	3.74		
11b	1Mbps	3	6	2437	26.98	26.45	26.81	31.52	3.74		
11b	1Mbps	3	11	2462	24.08	24.10	24.01	28.83	3.74		
11g	6Mbps	3	1	2412	24.43	23.45	23.70	28.65	3.74		
11g	6Mbps	3	6	2437	23.90	23.02	23.98	28.43	3.74		
11g	6Mbps	3	11	2462	25.86	25.74	25.71	30.54	3.74		
HT20	MCS0	3	1	2412	23.20	22.31	22.56	27.48	3.74		
HT20	MCS0	3	6	2437	25.06	23.84	24.61	29.30	3.74		
HT20	MCS0	3	11	2462	24.90	24.65	24.67	29.51	3.74		
HT40	MCS0	3	3	2422	20.03	19.57	18.65	24.23	3.74		
HT40	MCS0	3	6	2437	25.10	25.39	25.05	29.95	3.74		
HT40	MCS0	3	9	2452	21.13	21.40	20.84	25.90	3.74		

Note: Measured power (dBm) has offset with cable loss.

TEST RESULTS DATA
Average Output Power

2.4GHz Band															
Mod.	Data Rate	NTX	CH.	Freq. (MHz)	Duty Factor (dB)			Average Conducted Power with Duty Factor (dBm)				Conducted Power Limit (dBm)			Pass /Fail
					Ant 1	Ant 2	Ant 3	Ant 1	Ant 2	Ant 3	SUM	Ant 1	Ant 2	Ant 3	
11b	1Mbps	3	1	2412	0.00	0.00	0.00	21.28	20.15	20.21	25.35	30.00			Pass
11b	1Mbps	3	6	2437	0.00	0.00	0.00	24.01	23.55	23.55	28.48	30.00			Pass
11b	1Mbps	3	11	2462	0.00	0.00	0.00	20.88	20.89	20.76	25.61	30.00			Pass
11g	6Mbps	3	1	2412	0.13	0.13	0.13	15.33	14.58	14.79	19.68	30.00			Pass
11g	6Mbps	3	6	2437	0.13	0.13	0.13	15.08	14.19	15.03	19.55	30.00			Pass
11g	6Mbps	3	11	2462	0.13	0.13	0.13	17.08	16.99	16.87	21.75	30.00			Pass
HT20	MCS0	3	1	2412	0.14	0.11	0.11	14.05	13.32	13.82	18.51	30.00			Pass
HT20	MCS0	3	6	2437	0.14	0.11	0.11	15.98	15.07	15.62	20.34	30.00			Pass
HT20	MCS0	3	11	2462	0.14	0.11	0.11	16.00	15.65	15.57	20.52	30.00			Pass
HT40	MCS0	3	3	2422	0.22	0.18	0.23	11.22	10.83	10.05	15.50	30.00			Pass
HT40	MCS0	3	6	2437	0.22	0.18	0.23	16.42	16.38	16.11	21.08	30.00			Pass
HT40	MCS0	3	9	2452	0.22	0.18	0.23	12.23	12.53	12.03	17.04	30.00			Pass

Note: Measured power (dBm) has offset with cable loss.

TEST RESULTS DATA
Average Power Spectral Density

2.4GHz Band														
Mod.	Data Rate	NTX	CH.	Freq. (MHz)	Duty Factor (dB)			Average PSD with Duty Factor (dBm/3kHz)				DG (dBi)	Average PSD Limit (dBm/3kHz)	Pass/Fail
					Ant 1	Ant 2	Ant 3	Ant 1	Ant 2	Ant 3	Worse + 4.77			
11b	1Mbps	3	1	2412	0.00	0.00	0.00	-4.35	-4.92	-4.78	0.42	8.32	5.68	Pass
11b	1Mbps	3	6	2437	0.00	0.00	0.00	-1.12	-1.32	-0.66	4.11	8.32	5.68	Pass
11b	1Mbps	3	11	2462	0.00	0.00	0.00	-4.57	-4.16	-3.85	0.92	8.32	5.68	Pass
11g	6Mbps	3	1	2412	0.13	0.13	0.13	-13.29	-13.49	-13.95	-8.52	8.32	5.68	Pass
11g	6Mbps	3	6	2437	0.13	0.13	0.13	-13.98	-14.84	-13.63	-8.86	8.32	5.68	Pass
11g	6Mbps	3	11	2462	0.13	0.13	0.13	-11.81	-11.47	-11.56	-6.70	8.32	5.68	Pass
HT20	MCS0	3	1	2412	0.14	0.11	0.11	-13.78	-15.07	-14.90	-9.01	8.32	5.68	Pass
HT20	MCS0	3	6	2437	0.14	0.11	0.11	-13.12	-13.49	-13.01	-8.24	8.32	5.68	Pass
HT20	MCS0	3	11	2462	0.14	0.11	0.11	-12.83	-13.20	-13.19	-8.06	8.32	5.68	Pass
HT40	MCS0	3	3	2422	0.22	0.18	0.23	-19.02	-19.40	-20.44	-14.25	8.32	5.68	Pass
HT40	MCS0	3	6	2437	0.22	0.18	0.23	-12.92	-13.50	-14.23	-8.15	8.32	5.68	Pass
HT40	MCS0	3	9	2452	0.22	0.18	0.23	-18.53	-17.81	-18.34	-13.04	8.32	5.68	Pass

Measured power density (dBm) has offset with cable loss.



Appendix B. Radiated Spurious Emission

Test Engineer :	Tsung Lee and Stan Hsieh	Temperature :	25~26°C
		Relative Humidity :	48~49%

2.4GHz 2400~2483.5MHz

WIFI 802.11b (Band Edge @ 3m)

WIFI	Note	Frequency	Level	Over	Limit	Read	Antenna	Cable	Preamp	Ant	Table	Peak	Pol.	
Ant.				Limit	Line	Level	Factor	Loss	Factor	Pos	Pos	Avg.		
1+2+3		(MHz)	(dBμV/m)	(dB)	(dBμV/m)	(dBμV)	(dB/m)	(dB)	(dB)	(cm)	(deg)	(P/A)	(H/V)	
802.11b CH 01 2412MHz		2375.31	59.8	-14.2	74	60.46	27.19	5.39	33.24	373	123	P	H	
		2374.05	50.41	-3.59	54	51.07	27.19	5.39	33.24	373	123	A	H	
	*	2414	116.62	-	-	117.14	27.28	5.42	33.22	373	123	P	H	
	*	2414	113.8	-	-	114.32	27.28	5.42	33.22	373	123	A	H	
													H	
														H
			2389.59	62.04	-11.96	74	62.66	27.23	5.39	33.24	100	307	P	V
			2387.49	52.97	-1.03	54	53.59	27.23	5.39	33.24	100	307	A	V
	*		2412	120.78	-	-	121.3	27.28	5.42	33.22	100	307	P	V
	*		2412	117.54	-	-	118.06	27.28	5.42	33.22	100	307	A	V
														V
														V
802.11b CH 06 2437MHz		2338.42	57.48	-16.52	74	58.31	27.1	5.33	33.26	104	248	P	H	
		2387.98	47.28	-6.72	54	47.9	27.23	5.39	33.24	104	248	A	H	
	*	2438	113.25	-	-	113.67	27.37	5.42	33.21	104	248	P	H	
	*	2438	110.36	-	-	110.78	27.37	5.42	33.21	104	248	A	H	
			2485.32	57.37	-16.63	74	57.63	27.46	5.46	33.18	104	248	P	H
			2483.88	47.03	-6.97	54	47.29	27.46	5.46	33.18	104	248	A	H
			2388.26	62.21	-11.79	74	62.83	27.23	5.39	33.24	203	172	P	V
			2387.98	51.32	-2.68	54	51.94	27.23	5.39	33.24	203	172	A	V
	*		2438	123.38	-	-	123.8	27.37	5.42	33.21	203	172	P	V
	*		2438	120.57	-	-	120.99	27.37	5.42	33.21	203	172	A	V
			2484.72	63.07	-10.93	74	63.33	27.46	5.46	33.18	203	172	P	V
			2483.96	53.88	-0.12	54	54.14	27.46	5.46	33.18	203	172	A	V



802.11b CH 11 2462MHz	*	2462	112.95	-	-	113.3	27.41	5.44	33.2	129	119	P	H
	*	2464	109.78	-	-	110.13	27.41	5.44	33.2	129	119	A	H
		2499.12	59.98	-14.02	74	60.19	27.5	5.46	33.17	129	119	P	H
		2486.2	48.52	-5.48	54	48.78	27.46	5.46	33.18	129	119	A	H
													H
													H
	*	2462	119.11	-	-	119.46	27.41	5.44	33.2	323	167	P	V
	*	2460	116.13	-	-	116.48	27.41	5.44	33.2	323	167	A	V
		2499.96	62.37	-11.63	74	62.58	27.5	5.46	33.17	323	167	P	V
		2486.08	53.27	-0.73	54	53.53	27.46	5.46	33.18	323	167	A	V
													V
													V
Remark	1. No other spurious found. 2. All results are PASS against Peak and Average limit line.												



2.4GHz 2400~2483.5MHz

WIFI 802.11b (Harmonic @ 3m)

WIFI Ant. 1+2+3	Note	Frequency (MHz)	Level (dBμV/m)	Over Limit (dB)	Limit Line (dBμV/m)	Read Level (dBμV)	Antenna Factor (dB/m)	Cable Loss (dB)	Preamp Factor (dB)	Ant Pos (cm)	Table Pos (deg)	Peak Avg. (P/A)	Pol. (H/V)	
802.11b CH 01 2412MHz		4824	35.58	-38.42	74	579.18	-500	7.58	51.18	100	0	P	H	
													H	
													H	
													H	
			4824	37.71	-36.29	74	581.31	-500	7.58	51.18	100	0	P	V
														V
														V
802.11b CH 06 2437MHz		4872	44.25	-29.75	74	37.57	31.56	7.7	32.58	100	0	P	H	
		7313	49.99	-24.01	74	37.82	36.18	9.49	33.5	100	0	P	H	
													H	
													H	
			4872	44.03	-29.97	74	37.35	31.56	7.7	32.58	100	0	P	V
			7313	55.78	-18.22	74	43.61	36.18	9.49	33.5	384	145	P	V
			7313	51.4	-2.6	54	39.23	36.18	9.49	33.5	384	145	A	V
802.11b CH 11 2462MHz		4924	37.26	-36.74	74	48.8	31.66	7.93	51.13	100	0	P	H	
		7386	41.54	-32.46	74	46.44	36.37	9.53	50.8	100	0	P	H	
													H	
													H	
			4924	38.2	-35.8	74	49.74	31.66	7.93	51.13	100	0	P	V
			7386	41.93	-32.07	74	46.83	36.37	9.53	50.8	100	0	P	V
														V
Remark	1. No other spurious found.													
	2. All results are PASS against Peak and Average limit line.													



2.4GHz 2400~2483.5MHz

WIFI 802.11g (Band Edge @ 3m)

WIFI Ant. 1+2+3	Note	Frequency (MHz)	Level (dBμV/m)	Over Limit (dB)	Limit Line (dBμV/m)	Read Level (dBμV)	Antenna Factor (dB/m)	Cable Loss (dB)	Preamp Factor (dB)	Ant Pos (cm)	Table Pos (deg)	Peak Avg. (P/A)	Pol. (H/V)	
802.11g CH 01 2412MHz		2389.485	60.33	-13.67	74	60.95	27.23	5.39	33.24	327	140	P	H	
		2390	50.61	-3.39	54	51.21	27.23	5.39	33.22	327	140	A	H	
	*	2410	110.28	-	-	110.8	27.28	5.42	33.22	327	140	P	H	
	*	2410	103.06	-	-	103.58	27.28	5.42	33.22	327	140	A	H	
													H	
														H
			2390	66.2	-7.8	74	66.8	27.23	5.39	33.22	100	295	P	V
			2390	53.56	-0.44	54	54.16	27.23	5.39	33.22	100	295	A	V
	*		2410	116.39	-	-	116.91	27.28	5.42	33.22	100	295	P	V
	*		2410	108.62	-	-	109.14	27.28	5.42	33.22	100	295	A	V
														V
														V
802.11g CH 06 2437MHz		2352.98	57.24	-16.76	74	58.02	27.14	5.33	33.25	159	291	P	H	
		2389.94	47.89	-6.11	54	48.49	27.23	5.39	33.22	159	291	A	H	
	*	2437	107.82	-	-	108.24	27.37	5.42	33.21	159	291	P	H	
	*	2437	100.29	-	-	100.71	27.37	5.42	33.21	159	291	A	H	
			2488.8	56.84	-17.16	74	57.06	27.5	5.46	33.18	159	291	P	H
			2483.97	47.86	-6.14	54	48.12	27.46	5.46	33.18	159	291	A	H
			2388.96	57.83	-16.17	74	58.45	27.23	5.39	33.24	107	91	P	V
			2389.8	49.07	-4.93	54	49.67	27.23	5.39	33.22	107	91	A	V
	*		2437	114.61	-	-	115.03	27.37	5.42	33.21	107	91	P	V
	*		2437	106.83	-	-	107.25	27.37	5.42	33.21	107	91	A	V
			2483.83	62.26	-11.74	74	62.52	27.46	5.46	33.18	107	91	P	V
			2483.97	53.49	-0.51	54	53.75	27.46	5.46	33.18	107	91	A	V



802.11g CH 11 2462MHz	*	2460	112.38	-	-	112.73	27.41	5.44	33.2	390	129	P	H
	*	2464	104.64	-	-	104.99	27.41	5.44	33.2	390	129	A	H
		2490.16	60.54	-13.46	74	60.76	27.5	5.46	33.18	390	129	P	H
		2484.96	49.11	-4.89	54	49.37	27.46	5.46	33.18	390	129	A	H
													H
													H
	*	2464	118.22	-	-	118.57	27.41	5.44	33.2	339	176	P	V
	*	2464	110.57	-	-	110.92	27.41	5.44	33.2	339	176	A	V
		2484.92	65.69	-8.31	74	65.95	27.46	5.46	33.18	339	176	P	V
		2483.76	53.53	-0.47	54	53.79	27.46	5.46	33.18	339	176	A	V
													V
													V
Remark	1. No other spurious found. 2. All results are PASS against Peak and Average limit line.												



2.4GHz 2400~2483.5MHz

WIFI 802.11g (Harmonic @ 3m)

WIFI Ant. 1+2+3	Note	Frequency (MHz)	Level (dBμV/m)	Over Limit (dB)	Limit Line (dBμV/m)	Read Level (dBμV)	Antenna Factor (dB/m)	Cable Loss (dB)	Preamp Factor (dB)	Ant Pos (cm)	Table Pos (deg)	Peak Avg. (P/A)	Pol. (H/V)	
802.11g CH 01 2412MHz		4824	35.77	-38.23	74	47.91	31.46	7.58	51.18	100	0	P	H	
													H	
													H	
													H	
			4824	35.77	-38.23	74	47.91	31.46	7.58	51.18	100	0	P	V
														V
														V
802.11g CH 06 2437MHz		4874	35.73	-38.27	74	47.62	31.56	7.7	51.15	100	0	P	H	
		7311	40.92	-33.08	74	46.05	36.18	9.49	50.8	100	0	P	H	
													H	
													H	
			4874	34.28	-39.72	74	46.17	31.56	7.7	51.15	100	0	P	V
			7311	41.54	-32.46	74	46.67	36.18	9.49	50.8	100	0	P	V
														V
802.11g CH 11 2462MHz		4924	36.11	-37.89	74	47.65	31.66	7.93	51.13	100	0	P	H	
		7386	41.15	-32.85	74	46.05	36.37	9.53	50.8	100	0	P	H	
													H	
													H	
			4924	35.62	-38.38	74	47.16	31.66	7.93	51.13	100	0	P	V
			7386	42.17	-31.83	74	47.07	36.37	9.53	50.8	100	0	P	V
														V
Remark	1. No other spurious found.													
	2. All results are PASS against Peak and Average limit line.													



2.4GHz 2400~2483.5MHz

WIFI 802.11n HT20 (Band Edge @ 3m)

WIFI Ant. 1+2+3	Note	Frequency (MHz)	Level (dBμV/m)	Over Limit (dB)	Limit Line (dBμV/m)	Read Level (dBμV)	Antenna Factor (dB/m)	Cable Loss (dB)	Preamp Factor (dB)	Ant Pos (cm)	Table Pos (deg)	Peak Avg. (P/A)	Pol. (H/V)	
802.11n HT20 CH 01 2412MHz		2389.275	59.07	-14.93	74	59.69	27.23	5.39	33.24	310	295	P	H	
		2389.8	48.57	-5.43	54	49.17	27.23	5.39	33.22	310	295	A	H	
	*	2412	108.85	-	-	109.37	27.28	5.42	33.22	310	295	P	H	
	*	2412	101.33	-	-	101.85	27.28	5.42	33.22	310	295	A	H	
													H	
														H
			2389.695	66.31	-7.69	74	66.93	27.23	5.39	33.24	258	172	P	V
			2390	53.89	-0.11	54	54.49	27.23	5.39	33.22	258	172	A	V
		*	2412	115.1	-	-	115.62	27.28	5.42	33.22	258	172	P	V
		*	2412	107.56	-	-	108.08	27.28	5.42	33.22	258	172	A	V
													V	
													V	
802.11n HT20 CH 06 2437MHz		2365.44	56.48	-17.52	74	57.19	27.14	5.39	33.24	102	250	P	H	
		2389.94	47.19	-6.81	54	47.79	27.23	5.39	33.22	102	250	A	H	
	*	2437	107.77	-	-	108.19	27.37	5.42	33.21	102	250	P	H	
	*	2437	100.19	-	-	100.61	27.37	5.42	33.21	102	250	A	H	
			2484.81	57.04	-16.96	74	57.3	27.46	5.46	33.18	102	250	P	H
			2484.6	48.34	-5.66	54	48.6	27.46	5.46	33.18	102	250	A	H
			2387	59.1	-14.9	74	59.72	27.23	5.39	33.24	107	78	P	V
			2386.86	47.83	-6.17	54	48.45	27.23	5.39	33.24	107	78	A	V
		*	2437	114.88	-	-	115.3	27.37	5.42	33.21	107	78	P	V
		*	2437	107.5	-	-	107.92	27.37	5.42	33.21	107	78	A	V
		2483.5	63.01	-10.99	74	63.27	27.46	5.46	33.18	107	78	P	V	
		2485.09	53.65	-0.35	54	53.91	27.46	5.46	33.18	107	78	A	V	



802.11n HT20 CH 11 2462MHz	*	2462	106.33	-	-	106.68	27.41	5.44	33.2	100	144	P	H
	*	2462	98.91	-	-	99.26	27.41	5.44	33.2	100	144	A	H
		2483.76	58.09	-15.91	74	58.35	27.46	5.46	33.18	100	144	P	H
		2483.72	48.76	-5.24	54	49.02	27.46	5.46	33.18	100	144	A	H
													H
													H
	*	2462	116.57	-	-	116.92	27.41	5.44	33.2	365	163	P	V
	*	2462	108.86	-	-	109.21	27.41	5.44	33.2	365	163	A	V
		2489.92	65.76	-8.24	74	65.98	27.5	5.46	33.18	365	163	P	V
		2483.52	52.92	-1.08	54	53.18	27.46	5.46	33.18	365	163	A	V
													V
													V
Remark	1. No other spurious found. 2. All results are PASS against Peak and Average limit line.												



2.4GHz 2400~2483.5MHz

WIFI 802.11n HT20 (Harmonic @ 3m)

WIFI Ant. 1+2+3	Note	Frequency (MHz)	Level (dBμV/m)	Over Limit (dB)	Limit Line (dBμV/m)	Read Level (dBμV)	Antenna Factor (dB/m)	Cable Loss (dB)	Preamp Factor (dB)	Ant Pos (cm)	Table Pos (deg)	Peak Avg. (P/A)	Pol. (H/V)	
802.11n HT20 CH 01 2412MHz		4824	36.13	-37.87	74	48.27	31.46	7.58	51.18	100	0	P	H	
													H	
													H	
													H	
			4824	36.34	-37.66	74	48.48	31.46	7.58	51.18	100	0	P	V
														V
														V
802.11n HT20 CH 06 2437MHz		4872	35.31	-38.69	74	47.2	31.56	7.7	51.15	100	0	P	H	
		7309	41.4	-32.6	74	46.53	36.18	9.49	50.8	100	0	P	H	
													H	
													H	
			4872	34.31	-39.69	74	46.2	31.56	7.7	51.15	100	0	P	V
			7309	41.06	-32.94	74	46.19	36.18	9.49	50.8	100	0	P	V
														V
802.11n HT20 CH 11 2462MHz		4926	36.24	-37.76	74	47.78	31.66	7.93	51.13	100	0	P	H	
		7386	42.18	-31.82	74	47.08	36.37	9.53	50.8	100	0	P	H	
													H	
													H	
			4926	35.61	-38.39	74	47.15	31.66	7.93	51.13	100	0	P	V
			7386	41.54	-32.46	74	46.44	36.37	9.53	50.8	100	0	P	V
														V
Remark	1. No other spurious found.													
	2. All results are PASS against Peak and Average limit line.													



2.4GHz 2400~2483.5MHz

WIFI 802.11n HT40 (Band Edge @ 3m)

WIFI Ant. 1+2+3	Note	Frequency (MHz)	Level (dBμV/m)	Over Limit (dB)	Limit Line (dBμV/m)	Read Level (dBμV)	Antenna Factor (dB/m)	Cable Loss (dB)	Preamp Factor (dB)	Ant Pos (cm)	Table Pos (deg)	Peak Avg. (P/A)	Pol. (H/V)
802.11n HT40 CH 03 2422MHz		2389.38	58.96	-15.04	74	59.58	27.23	5.39	33.24	350	283	P	H
		2389.66	50.52	-3.48	54	51.14	27.23	5.39	33.24	350	283	A	H
	*	2422	103.94	-	-	104.41	27.32	5.42	33.21	350	283	P	H
	*	2422	96.58	-	-	97.05	27.32	5.42	33.21	350	283	A	H
		2499.02	56.72	-17.28	74	56.93	27.5	5.46	33.17	350	283	P	H
		2499.58	47.95	-6.05	54	48.16	27.5	5.46	33.17	350	283	A	H
		2389.8	61.78	-12.22	74	62.38	27.23	5.39	33.22	113	293	P	V
		2389.38	52.96	-1.04	54	53.58	27.23	5.39	33.24	113	293	A	V
	*	2422	110.9	-	-	111.37	27.32	5.42	33.21	113	293	P	V
	*	2422	103.51	-	-	103.98	27.32	5.42	33.21	113	293	A	V
		2492.58	58.37	-15.63	74	58.58	27.5	5.46	33.17	113	293	P	V
		2484.81	49.5	-4.5	54	49.76	27.46	5.46	33.18	113	293	A	V
802.11n HT40 CH 06 2437MHz		2386.02	57.84	-16.16	74	58.46	27.23	5.39	33.24	347	123	P	H
		2389.8	49.58	-4.42	54	50.18	27.23	5.39	33.22	347	123	A	H
	*	2437	106.25	-	-	106.67	27.37	5.42	33.21	347	123	P	H
	*	2437	99.36	-	-	99.78	27.37	5.42	33.21	347	123	A	H
		2495.03	57.67	-16.33	74	57.88	27.5	5.46	33.17	347	123	P	H
		2483.62	49.39	-4.61	54	49.65	27.46	5.46	33.18	347	123	A	H
		2381.4	59.86	-14.14	74	60.52	27.19	5.39	33.24	235	214	P	V
		2389.8	51.24	-2.76	54	51.84	27.23	5.39	33.22	235	214	A	V
	*	2437	115.1	-	-	115.52	27.37	5.42	33.21	235	214	P	V
	*	2437	107.73	-	-	108.15	27.37	5.42	33.21	235	214	A	V
		2485.37	63.02	-10.98	74	63.28	27.46	5.46	33.18	235	214	P	V
		2484.25	53.47	-0.53	54	53.73	27.46	5.46	33.18	235	214	A	V



802.11n HT40 CH 09 2452MHz		2374.82	57.13	-16.87	74	57.79	27.19	5.39	33.24	386	129	P	H
		2325.12	48.57	-5.43	54	49.45	27.05	5.33	33.26	386	129	A	H
	*	2452	103.11	-	-	103.5	27.37	5.44	33.2	386	129	P	H
	*	2452	95.74	-	-	96.13	27.37	5.44	33.2	386	129	A	H
		2486	58.63	-15.37	74	58.89	27.46	5.46	33.18	386	129	P	H
		2486	49.67	-4.33	54	49.93	27.46	5.46	33.18	386	129	A	H
		2374.68	57.2	-16.8	74	57.86	27.19	5.39	33.24	319	163	P	V
		2386.02	47.81	-6.19	54	48.43	27.23	5.39	33.24	319	163	A	V
	*	2452	109.3	-	-	109.69	27.37	5.44	33.2	319	163	P	V
	*	2452	101.9	-	-	102.29	27.37	5.44	33.2	319	163	A	V
		2483.83	61.72	-12.28	74	61.98	27.46	5.46	33.18	319	163	P	V
		2484.04	52.78	-1.22	54	53.04	27.46	5.46	33.18	319	163	A	V
Remark	1. No other spurious found. 2. All results are PASS against Peak and Average limit line.												



2.4GHz 2400~2483.5MHz

WIFI 802.11n HT40 (Harmonic @ 3m)

WIFI Ant. 1+2+3	Note	Frequency (MHz)	Level (dBμV/m)	Over Limit (dB)	Limit Line (dBμV/m)	Read Level (dBμV)	Antenna Factor (dB/m)	Cable Loss (dB)	Preamp Factor (dB)	Ant Pos (cm)	Table Pos (deg)	Peak Avg. (P/A)	Pol. (H/V)
802.11n HT40 CH 03 2422MHz		4842	36.23	-37.77	74	48.2	31.49	7.7	51.16	100	0	P	H
		7266	42.51	-31.49	74	47.74	36.11	9.46	50.8	100	0	P	H
													H
													H
		4842	35.78	-38.22	74	47.75	31.49	7.7	51.16	100	0	P	V
		7266	41.17	-32.83	74	46.4	36.11	9.46	50.8	100	0	P	V
802.11n HT40 CH 06 2437MHz		4872	35.2	-38.8	74	47.09	31.56	7.7	51.15	100	0	P	H
		7309	42.84	-31.16	74	47.97	36.18	9.49	50.8	100	0	P	H
													H
													H
		4872	34.27	-39.73	74	46.16	31.56	7.7	51.15	100	0	P	V
		7309	42.17	-31.83	74	47.3	36.18	9.49	50.8	100	0	P	V
802.11n HT40 CH 09 2452MHz		4902	35.91	-38.09	74	47.61	31.63	7.82	51.15	100	0	P	H
		7356	42.53	-31.47	74	47.52	36.3	9.51	50.8	100	0	P	H
													H
													H
		4902	35.85	-38.15	74	47.55	31.63	7.82	51.15	100	0	P	V
		7356	41.51	-32.49	74	46.5	36.3	9.51	50.8	100	0	P	V
Remark	1. No other spurious found.												
	2. All results are PASS against Peak and Average limit line.												



2.4GHz 2400~2483.5MHz

Emission below 1GHz

2.4GHz WIFI 802.11b (LF)

WIFI Ant.	Note	Frequency	Level	Over Limit	Limit Line	Read Level	Antenna Factor	Cable Loss	Preamp Factor	Ant Pos	Table Pos	Peak Avg.	Pol.	
1+2+3		(MHz)	(dBμV/m)	(dB)	(dBμV/m)	(dBμV)	(dB/m)	(dB)	(dB)	(cm)	(deg)	(P/A)	(H/V)	
2.4GHz 802.11b LF		82.65	36.59	-3.41	40	54.2	14.14	0.93	32.68	100	0	P	H	
		189.57	38.83	-4.67	43.5	54.47	15.6	1.48	32.72			P	H	
		282.18	41.73	-4.27	46	53.34	19.36	1.76	32.73			P	H	
		381.9	39.22	-6.78	46	47.93	21.98	2.13	32.82			P	H	
		597.5	35.23	-10.77	46	40.25	25.44	2.57	33.03			P	H	
		650	39.37	-6.63	46	43.71	26	2.67	33.01			P	H	
														H
														H
														H
														H
														H
														H
			82.38	36.75	-3.25	40	54.36	14.14	0.93	32.68	100	0	P	V
			172.02	39.41	-4.09	43.5	54.56	16.07	1.48	32.7			P	V
			281.91	39.24	-6.76	46	50.85	19.36	1.76	32.73			P	V
			302.1	36.48	-9.52	46	47.54	19.79	1.88	32.73			P	V
			597.5	35	-11	46	40.02	25.44	2.57	33.03			P	V
			650	36.99	-9.01	46	41.33	26	2.67	33.01			P	V
														V
														V
													V	
													V	
													V	
													V	
Remark	1. No other spurious found. 2. All results are PASS against limit line.													



Emission below 1GHz

2.4GHz WIFI 802.11g (LF)

WIFI	Note	Frequency	Level	Over	Limit	Read	Antenna	Cable	Preamp	Ant	Table	Peak	Pol.	
Ant.				Limit	Line	Level	Factor	Loss	Factor	Pos	Pos	Avg.		
1+2+3		(MHz)	(dBμV/m)	(dB)	(dBμV/m)	(dBμV)	(dB/m)	(dB)	(dB)	(cm)	(deg)	(P/A)	(H/V)	
2.4GHz 802.11g LF		82.11	36.13	-3.87	40	53.74	14.14	0.93	32.68	100	0	P	H	
		186.87	38.7	-4.8	43.5	54.37	15.57	1.48	32.72			P	H	
		282.18	41.43	-4.57	46	53.04	19.36	1.76	32.73			P	H	
		370.7	39.05	-6.95	46	48.04	21.69	2.13	32.81			P	H	
		597.5	35.33	-10.67	46	40.35	25.44	2.57	33.03			P	H	
		650	39.95	-6.05	46	44.29	26	2.67	33.01			P	H	
														H
														H
														H
														H
														H
														H
			80.49	36.58	-3.42	40	54.44	13.9	0.93	32.69	100	0	P	V
			170.94	38.78	-4.72	43.5	53.86	16.14	1.48	32.7			P	V
			284.07	41.18	-4.82	46	52.73	19.42	1.76	32.73			P	V
			323.1	33.49	-12.51	46	43.98	20.39	1.88	32.76			P	V
			597.5	35.02	-10.98	46	40.04	25.44	2.57	33.03			P	V
			650	35.33	-10.67	46	39.67	26	2.67	33.01			P	V
														V
														V
													V	
													V	
													V	
													V	
Remark	1. No other spurious found. 2. All results are PASS against limit line.													



Emission below 1GHz

2.4GHz WIFI 802.11n HT20 (LF)

WIFI	Note	Frequency	Level	Over	Limit	Read	Antenna	Cable	Preamp	Ant	Table	Peak	Pol.	
Ant.				Limit	Line	Level	Factor	Loss	Factor	Pos	Pos	Avg.		
1+2+3		(MHz)	(dBμV/m)	(dB)	(dBμV/m)	(dBμV)	(dB/m)	(dB)	(dB)	(cm)	(deg)	(P/A)	(H/V)	
2.4GHz 802.11n HT20 LF		81.57	35.95	-4.05	40	53.69	14.02	0.93	32.69	100	0	P	H	
		169.32	39.04	-4.46	43.5	54.06	16.2	1.48	32.7			P	H	
		282.18	40.7	-5.3	46	52.31	19.36	1.76	32.73			P	H	
		374.2	38.25	-7.75	46	47.14	21.79	2.13	32.81			P	H	
		483.4	33.64	-12.36	46	40.4	23.85	2.3	32.91			P	H	
		650	39.45	-6.55	46	43.79	26	2.67	33.01			P	H	
														H
														H
														H
														H
														H
														H
														H
			78.06	36.94	-3.06	40	55.05	13.66	0.93	32.7	100	0	P	V
			165.54	37.08	-6.42	43.5	51.77	16.52	1.48	32.69			P	V
			282.99	38.38	-7.62	46	49.96	19.39	1.76	32.73			P	V
			526.1	34.24	-11.76	46	40.37	24.35	2.47	32.95			P	V
			597.5	34.16	-11.84	46	39.18	25.44	2.57	33.03			P	V
			650	35.09	-10.91	46	39.43	26	2.67	33.01			P	V
														V
													V	
													V	
													V	
													V	
													V	
Remark	1. No other spurious found. 2. All results are PASS against limit line.													



Emission below 1GHz

2.4GHz WIFI 802.11n HT40 (LF)

WIFI	Note	Frequency	Level	Over	Limit	Read	Antenna	Cable	Preamp	Ant	Table	Peak	Pol.	
Ant.				Limit	Line	Level	Factor	Loss	Factor	Pos	Pos	Avg.		
1+2+3		(MHz)	(dBμV/m)	(dB)	(dBμV/m)	(dBμV)	(dB/m)	(dB)	(dB)	(cm)	(deg)	(P/A)	(H/V)	
2.4GHz 802.11n HT40 LF		80.49	36.72	-3.28	40	54.58	13.9	0.93	32.69	100	58	P	H	
		165.54	39.72	-3.78	43.5	54.41	16.52	1.48	32.69			P	H	
		282.72	41.68	-4.32	46	53.26	19.39	1.76	32.73			P	H	
		393.8	39.66	-6.34	46	48.1	22.26	2.13	32.83			P	H	
		597.5	35.93	-10.07	46	40.95	25.44	2.57	33.03			P	H	
		650	41.91	-4.09	46	46.25	26	2.67	33.01			P	H	
														H
														H
														H
														H
														H
														H
			81.3	36.99	-3.01	40	54.73	14.02	0.93	32.69	100	67	P	V
			149.34	39.82	-3.68	43.5	53.44	17.73	1.33	32.68			P	V
			282.72	42.38	-3.62	46	53.96	19.39	1.76	32.73			P	V
			330.8	35.98	-10.02	46	46.18	20.62	1.94	32.76			P	V
			597.5	34.08	-11.92	46	39.1	25.44	2.57	33.03			P	V
			650	38.64	-7.36	46	42.98	26	2.67	33.01			P	V
													V	
													V	
													V	
													V	
													V	
													V	
Remark	1. No other spurious found. 2. All results are PASS against limit line.													



Note symbol

*	Fundamental Frequency which can be ignored. However, the level of any unwanted emissions shall not exceed the level of the fundamental frequency.
!	Test result is over limit line.
P/A	Peak or Average
H/V	Horizontal or Vertical



A calculation example for radiated spurious emission is shown as below:

WIFI	Note	Frequency	Level	Over	Limit	Read	Antenna	Cable	Preamp	Ant	Table	Peak	Pol.
Ant.				Limit	Line	Level	Factor	Loss	Factor	Pos	Pos	Avg.	
1		(MHz)	(dBμV/m)	(dB)	(dBμV/m)	(dBμV)	(dB/m)	(dB)	(dB)	(cm)	(deg)	(P/A)	(H/V)
802.11b		2390	55.45	-18.55	74	54.51	32.22	4.58	35.86	103	308	P	H
CH 01													
2412MHz		2390	43.54	-10.46	54	42.6	32.22	4.58	35.86	103	308	A	H

- Level(dBμV/m) =
Antenna Factor(dB/m) + Cable Loss(dB) + Read Level(dBμV) - Preamp Factor(dB)
- Over Limit(dB) = Level(dBμV/m) – Limit Line(dBμV/m)

For Peak Limit @ 2390MHz:

- Level(dBμV/m)
= Antenna Factor(dB/m) + Cable Loss(dB) + Read Level(dBμV) - Preamp Factor(dB)
= 32.22(dB/m) + 4.58(dB) + 54.51(dBμV) – 35.86 (dB)
= 55.45 (dBμV/m)
- Over Limit(dB)
= Level(dBμV/m) – Limit Line(dBμV/m)
= 55.45(dBμV/m) – 74(dBμV/m)
= -18.55(dB)

For Average Limit @ 2390MHz:

- Level(dBμV/m)
= Antenna Factor(dB/m) + Cable Loss(dB) + Read Level(dBμV) - Preamp Factor(dB)
= 32.22(dB/m) + 4.58(dB) + 42.6(dBμV) – 35.86 (dB)
= 43.54 (dBμV/m)
- Over Limit(dB)
= Level(dBμV/m) – Limit Line(dBμV/m)
= 43.54(dBμV/m) – 54(dBμV/m)
= -10.46(dB)

Both peak and average measured complies with the limit line, so test result is “PASS”.



Appendix C. Radiated Spurious Emission Plots

Test Engineer :	Tsung Lee and Stan Hsieh	Temperature :	25~26°C
		Relative Humidity :	48~49%

Note symbol

-L	Low channel location
-R	High channel location

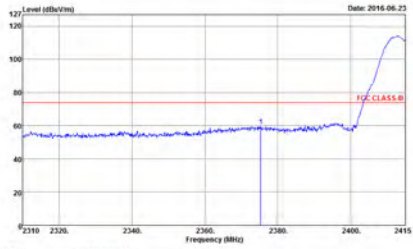
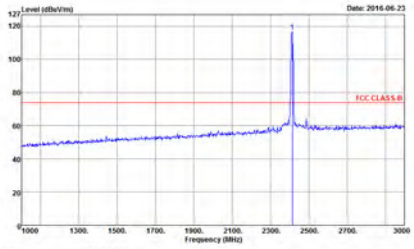
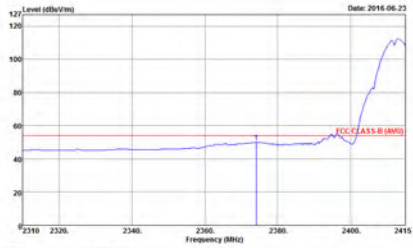
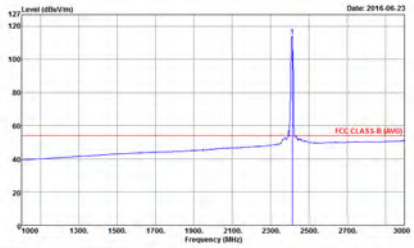

2.4GHz 2400~2483.5MHz
WIFI 802.11b (Band Edge @ 3m)

WIFI	2.4GHz 2400~2483.5MHz Band Edge @ 3m	
ANT	802.11b CH01 2412MHz	
1+2+3	Horizontal	Fundamental
Peak	 <p>Site : 03CH0-HY Condition : FCC CLASS-B 3m HORN 91200-HF HORIZONTAL Detector : Peak Project : 652049 Mode : 7</p>	 <p>Site : 03CH0-HY Condition : FCC CLASS-B 3m HORN 91200-HF HORIZONTAL Detector : Peak Project : 652049 Mode : 7</p>
Avg.	 <p>Site : 03CH0-HY Condition : FCC CLASS-B (AVG) 3m HORN 91200-HF HORIZONTAL Detector : Peak Project : 652049 Mode : 7</p>	 <p>Site : 03CH0-HY Condition : FCC CLASS-B (AVG) 3m HORN 91200-HF HORIZONTAL Detector : Peak Project : 652049 Mode : 7</p>

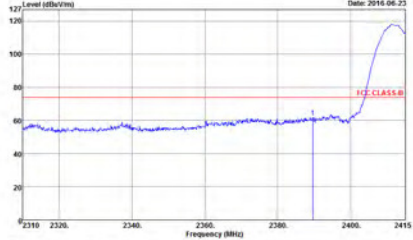
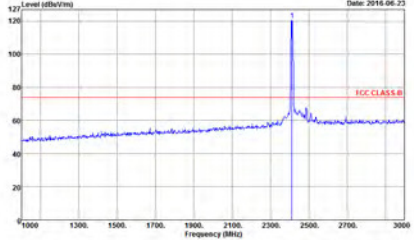
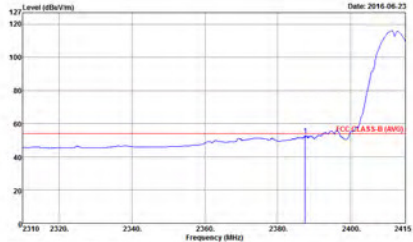
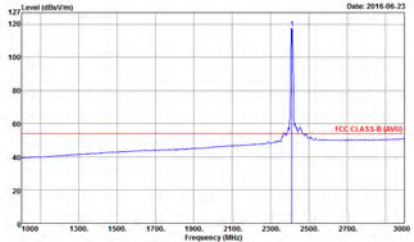

WIFI	2.4GHz 2400~2483.5MHz Band Edge @ 3m	
ANT	802.11b CH01 2412MHz	
1+2+3	Vertical	Fundamental
Peak	 <p>Site : 03CH10-HY Condition : FCC CLASS-B 3m HORN 91200-HF VERTICAL RBW:1000.000KHz VBW:3000.000KHz SWT:Auto Detector : Peak Project : 652049 Mode : 7</p>	 <p>Site : 03CH10-HY Condition : FCC CLASS-B 3m HORN 91200-HF VERTICAL RBW:1000.000KHz VBW:3000.000KHz SWT:Auto Detector : Peak Project : 652049 Mode : 7</p>
Avg.	 <p>Site : 03CH10-HY Condition : FCC CLASS-B (AVG) 3m HORN 91200-HF VERTICAL RBW:1000.000KHz VBW:0.010KHz SWT:Auto Detector : Peak Project : 652049 Mode : 7</p>	 <p>Site : 03CH10-HY Condition : FCC CLASS-B (AVG) 3m HORN 91200-HF VERTICAL RBW:1000.000KHz VBW:0.010KHz SWT:Auto Detector : Peak Project : 652049 Mode : 7</p>

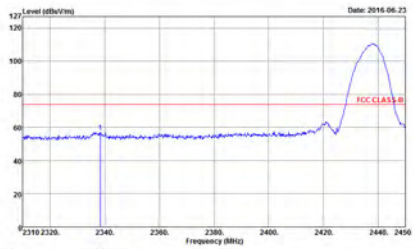
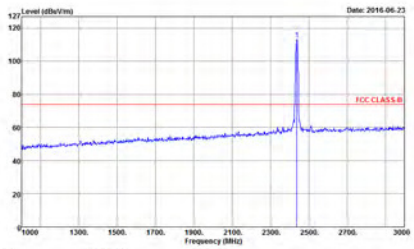
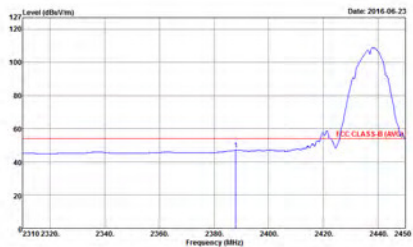
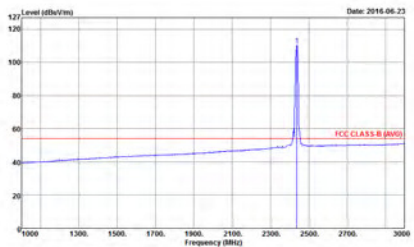

WIFI	2.4GHz 2400~2483.5MHz Band Edge @ 3m	
ANT	802.11b CH06 2437MHz - L	
1+2+3	Horizontal	Fundamental
Peak	 <p>Site : 03CH10-HY Condition : FCC CLASS-B 3m HORN 91200-HF HORIZONTAL RBW:1000.000KHz VBW:3000.000KHz SWT:Auto Detector : Peak Project : 652049 Mode : 8</p>	 <p>Site : 03CH10-HY Condition : FCC CLASS-B 3m HORN 91200-HF HORIZONTAL RBW:1000.000KHz VBW:3000.000KHz SWT:Auto Detector : Peak Project : 652049 Mode : 8</p>
Avg.	 <p>Site : 03CH10-HY Condition : FCC CLASS-B (AVG) 3m HORN 91200-HF HORIZONTAL RBW:1000.000KHz VBW:0.010KHz SWT:Auto Detector : Peak Project : 652049 Mode : 8</p>	 <p>Site : 03CH10-HY Condition : FCC CLASS-B (AVG) 3m HORN 91200-HF HORIZONTAL RBW:1000.000KHz VBW:0.010KHz SWT:Auto Detector : Peak Project : 652049 Mode : 8</p>



WIFI	2.4GHz 2400~2483.5MHz Band Edge @ 3m	
ANT	802.11b CH06 2437MHz - R	
1+2+3	Horizontal	Fundamental
Peak	<p>Site : 03CH10-HY Condition : FCC CLASS-B 3m HORN 91200-HF HORIZONTAL RBW:1000.000KHz VBW:3000.000KHz SWT:Auto Detector : Peak Project : 652049 Mode : B</p>	Left blank
Avg.	<p>Site : 03CH10-HY Condition : FCC CLASS-B (AVG) 3m HORN 91200-HF HORIZONTAL RBW:1000.000KHz VBW:0.010KHz SWT:Auto Detector : Peak Project : 652049 Mode : B</p>	Left blank



WIFI	2.4GHz 2400~2483.5MHz Band Edge @ 3m	
ANT	802.11b CH06 2437MHz - L	
1+2+3	Vertical	Fundamental
Peak	<p>Site : 03CH10-HY Condition : FCC CLASS-B 3m HORN 91200-HF VERTICAL RBW:1000.000KHz VBW:3000.000KHz SWT:Auto Detector : Peak Project : 652049 Mode : 8</p>	<p>Site : 03CH10-HY Condition : FCC CLASS-B 3m HORN 91200-HF VERTICAL RBW:1000.000KHz VBW:3000.000KHz SWT:Auto Detector : Peak Project : 652049 Mode : 8</p>
Avg.	<p>Site : 03CH10-HY Condition : FCC CLASS-B (AVG) 3m HORN 91200-HF VERTICAL RBW:1000.000KHz VBW:0.010KHz SWT:Auto Detector : Peak Project : 652049 Mode : 8</p>	<p>Site : 03CH10-HY Condition : FCC CLASS-B (AVG) 3m HORN 91200-HF VERTICAL RBW:1000.000KHz VBW:0.010KHz SWT:Auto Detector : Peak Project : 652049 Mode : 8</p>

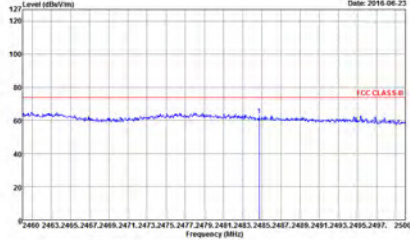
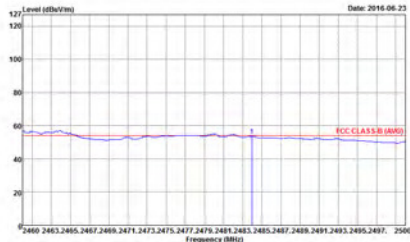

WIFI	2.4GHz 2400~2483.5MHz Band Edge @ 3m	
ANT	802.11b CH06 2437MHz - R	
1+2+3	Vertical	Fundamental
Peak	 <p>Site : 03CH10-HY Condition : FCC CLASS-B 3m HORN 9120D-HF VERTICAL RBW:1000.000KHz VBW:3000.000KHz SWT:Auto Detector : Peak Project : 652049 Mode : B</p>	Left blank
Avg.	 <p>Site : 03CH10-HY Condition : FCC CLASS-B (AVG) 3m HORN 9120D-HF VERTICAL RBW:1000.000KHz VBW:0.010KHz SWT:Auto Detector : Peak Project : 652049 Mode : B</p>	Left blank



WIFI	2.4GHz 2400~2483.5MHz Band Edge @ 3m	
ANT	802.11b CH11 2462MHz	
1+2+3	Horizontal	Fundamental
Peak	<p>Site : 03CH10-HY Condition : FCC CLASS-B 3m HORN 91200-HF HORIZONTAL RBW:1000.000KHz VBW:3000.000KHz SWT:Auto Detector : Peak Project : 652049 Mode : 9</p>	<p>Site : 03CH10-HY Condition : FCC CLASS-B 3m HORN 91200-HF HORIZONTAL RBW:1000.000KHz VBW:3000.000KHz SWT:Auto Detector : Peak Project : 652049 Mode : 9</p>
Avg.	<p>Site : 03CH10-HY Condition : FCC CLASS-B (AVG) 3m HORN 91200-HF HORIZONTAL RBW:1000.000KHz VBW:0.010KHz SWT:Auto Detector : Peak Project : 652049 Mode : 9</p>	<p>Site : 03CH10-HY Condition : FCC CLASS-B (AVG) 3m HORN 91200-HF HORIZONTAL RBW:1000.000KHz VBW:0.010KHz SWT:Auto Detector : Peak Project : 652049 Mode : 9</p>

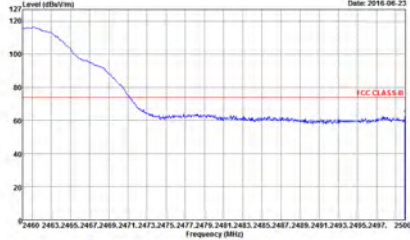
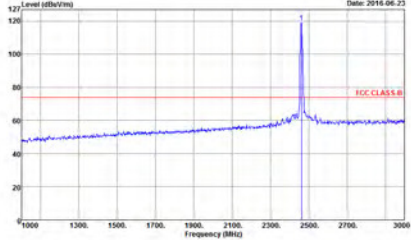
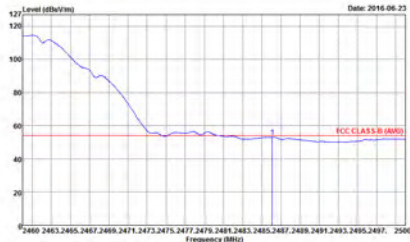
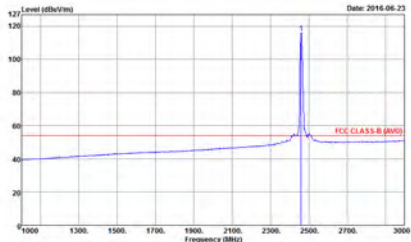

WIFI	2.4GHz 2400~2483.5MHz Band Edge @ 3m	
ANT	802.11b CH11 2462MHz	
1+2+3	Vertical	Fundamental
Peak	 <p>Site : 03CH10-HY Condition : FCC CLASS-B 3m HORN 91200-HF VERTICAL RBW:1000.000KHz VBW:3000.000KHz SWT:Auto Detector : Peak Project : 652049 Mode : 9</p>	 <p>Site : 03CH10-HY Condition : FCC CLASS-B 3m HORN 91200-HF VERTICAL RBW:1000.000KHz VBW:3000.000KHz SWT:Auto Detector : Peak Project : 652049 Mode : 9</p>
Avg.	 <p>Site : 03CH10-HY Condition : FCC CLASS-B (AVG) 3m HORN 91200-HF VERTICAL RBW:1000.000KHz VBW:0.010KHz SWT:Auto Detector : Peak Project : 652049 Mode : 9</p>	 <p>Site : 03CH10-HY Condition : FCC CLASS-B (AVG) 3m HORN 91200-HF VERTICAL RBW:1000.000KHz VBW:0.010KHz SWT:Auto Detector : Peak Project : 652049 Mode : 9</p>



2.4GHz 2400~2483.5MHz
WIFI 802.11g (Band Edge @ 3m)

WIFI	2.4GHz 2400~2483.5MHz Band Edge @ 3m	
ANT	802.11g CH01 2412MHz	
1+2+3	Horizontal	Fundamental
Peak	<p>Site : 03CH0-HY Condition : FCC CLASS-B 3m HORN 91200-HF HORIZONTAL RBW:1000.000KHz VBW:3000.000KHz SWT:Auto Detector : Peak Project : 652049 Mode : IZ Setting : 14.5</p>	<p>Site : 03CH0-HY Condition : FCC CLASS-B 3m HORN 91200-HF HORIZONTAL RBW:1000.000KHz VBW:3000.000KHz SWT:Auto Detector : Peak Project : 652049 Mode : IZ Setting : 14.5</p>
Avg.	<p>Site : 03CH0-HY Condition : FCC CLASS-B (AVG) 3m HORN 91200-HF HORIZONTAL RBW:1000.000KHz VBW:1.000KHz SWT:Auto Detector : Peak Project : 652049 Mode : IZ Setting : 14.5</p>	<p>Site : 03CH0-HY Condition : FCC CLASS-B (AVG) 3m HORN 91200-HF HORIZONTAL RBW:1000.000KHz VBW:1.000KHz SWT:Auto Detector : Peak Project : 652049 Mode : IZ Setting : 14.5</p>

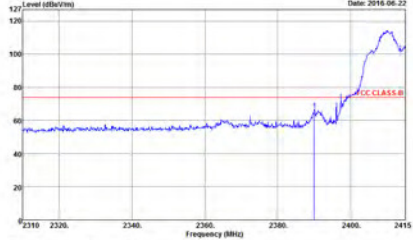
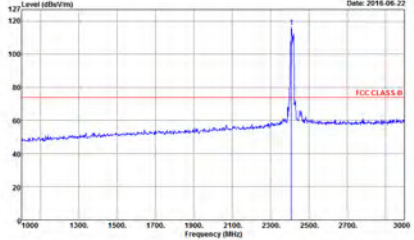
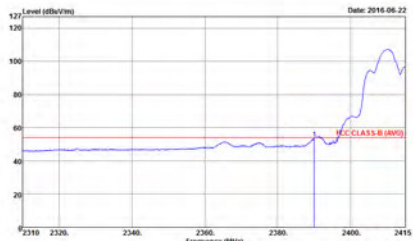
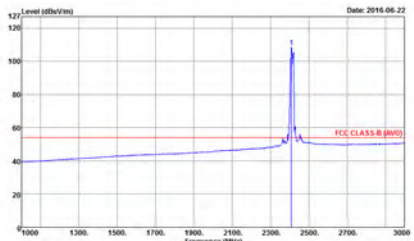

WIFI	2.4GHz 2400~2483.5MHz Band Edge @ 3m	
ANT	802.11g CH01 2412MHz	
1+2+3	Vertical	Fundamental
Peak	 <p>Site : 03CH0-HY Condition : FCC CLASS-B 3m HORN 91200-HF VERTICAL RBW:1000.000KHz VBW:3000.000KHz SWT:Auto Detector : Peak Project : 652049 Mode : 12 Setting : 14.5</p>	 <p>Site : 03CH0-HY Condition : FCC CLASS-B 3m HORN 91200-HF VERTICAL RBW:1000.000KHz VBW:3000.000KHz SWT:Auto Detector : Peak Project : 652049 Mode : 12 Setting : 14.5</p>
Avg.	 <p>Site : 03CH0-HY Condition : FCC CLASS-B (AVG) 3m HORN 91200-HF VERTICAL RBW:1000.000KHz VBW:1.000KHz SWT:Auto Detector : Peak Project : 652049 Mode : 12 Setting : 14.5</p>	 <p>Site : 03CH0-HY Condition : FCC CLASS-B (AVG) 3m HORN 91200-HF VERTICAL RBW:1000.000KHz VBW:1.000KHz SWT:Auto Detector : Peak Project : 652049 Mode : 12 Setting : 14.5</p>

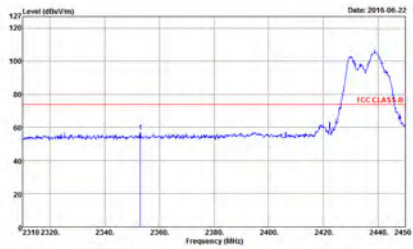
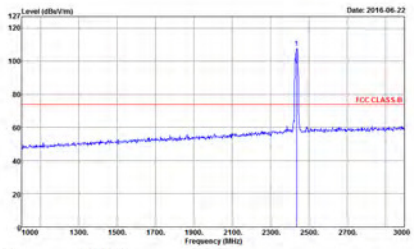
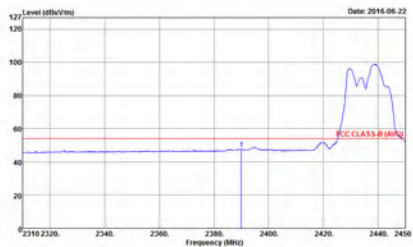
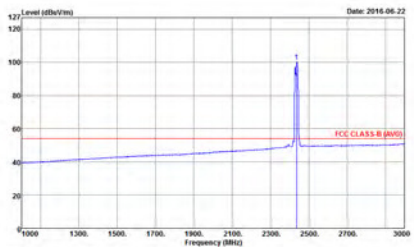

WIFI	2.4GHz 2400~2483.5MHz Band Edge @ 3m	
ANT	802.11g CH06 2437MHz - L	
1+2+3	Horizontal	Fundamental
Peak	 <p>Site : 03CH10-HY Condition : FCC CLASS-B 3m HORN 91200-HF HORIZONTAL RBW:1000.000KHz VBW:3000.000KHz SWT:Auto Detector : Peak Project : 652049 Mode : II Setting : 14.5</p>	 <p>Site : 03CH10-HY Condition : FCC CLASS-B 3m HORN 91200-HF HORIZONTAL RBW:1000.000KHz VBW:3000.000KHz SWT:Auto Detector : Peak Project : 652049 Mode : II Setting : 14.5</p>
Avg.	 <p>Site : 03CH10-HY Condition : FCC CLASS-B (AVG) 3m HORN 91200-HF HORIZONTAL RBW:1000.000KHz VBW:1.000KHz SWT:Auto Detector : Peak Project : 652049 Mode : II Setting : 14.5</p>	 <p>Site : 03CH10-HY Condition : FCC CLASS-B (AVG) 3m HORN 91200-HF HORIZONTAL RBW:1000.000KHz VBW:1.000KHz SWT:Auto Detector : Peak Project : 652049 Mode : II Setting : 14.5</p>

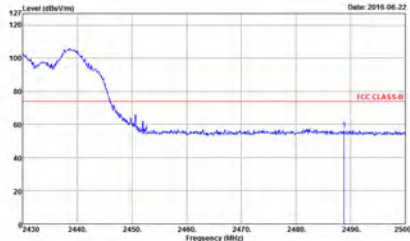
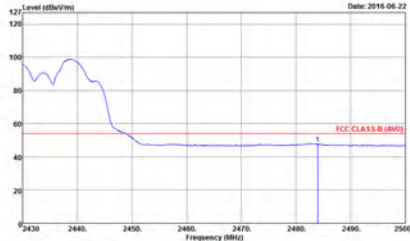

WIFI	2.4GHz 2400~2483.5MHz Band Edge @ 3m	
ANT	802.11g CH06 2437MHz - R	
1+2+3	Horizontal	Fundamental
<p>Peak</p>	 <p>Site : 03CH10-HY Condition : FCC CLASS-B 3m HORN 91200-HF HORIZONTAL RBW:1000.000KHz VBW:3000.000KHz SWT:Auto Detector : Peak Project : 652049 Mode : 11 Setting : 14.5</p>	<p>Left blank</p>
<p>Avg.</p>	 <p>Site : 03CH10-HY Condition : FCC CLASS-B (AVG) 3m HORN 91200-HF HORIZONTAL RBW:1000.000KHz VBW:1.000KHz SWT:Auto Detector : Peak Project : 652049 Mode : 11 Setting : 14.5</p>	<p>Left blank</p>

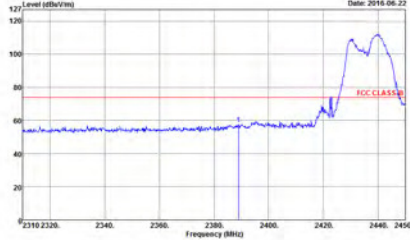
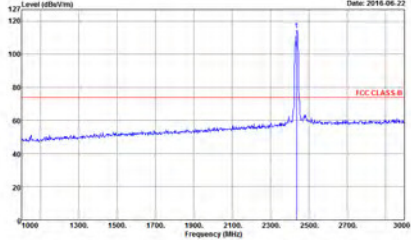
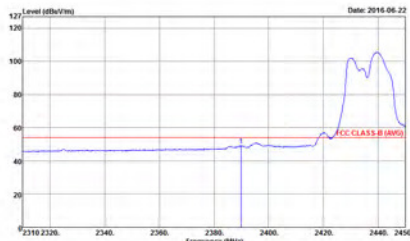
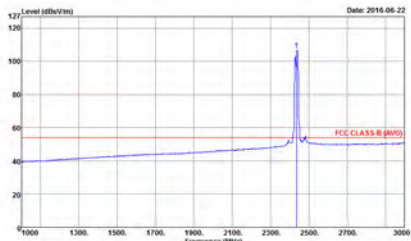

WIFI	2.4GHz 2400~2483.5MHz Band Edge @ 3m	
ANT	802.11g CH06 2437MHz - L	
1+2+3	Vertical	Fundamental
Peak	 <p>Site : 03CH0-HY Condition : FCC CLASS-B 3m HORN 91200-HF VERTICAL RBW:1000.000KHz VBW:3000.000KHz SWT:Auto Detector : Peak Project : 652049 Mode : II Setting : 14.5</p>	 <p>Site : 03CH0-HY Condition : FCC CLASS-B 3m HORN 91200-HF VERTICAL RBW:1000.000KHz VBW:3000.000KHz SWT:Auto Detector : Peak Project : 652049 Mode : II Setting : 14.5</p>
Avg.	 <p>Site : 03CH0-HY Condition : FCC CLASS-B (AVG) 3m HORN 91200-HF VERTICAL RBW:1000.000KHz VBW:1.000KHz SWT:Auto Detector : Peak Project : 652049 Mode : II Setting : 14.5</p>	 <p>Site : 03CH0-HY Condition : FCC CLASS-B (AVG) 3m HORN 91200-HF VERTICAL RBW:1000.000KHz VBW:1.000KHz SWT:Auto Detector : Peak Project : 652049 Mode : II Setting : 14.5</p>



WIFI	2.4GHz 2400~2483.5MHz Band Edge @ 3m	
ANT	802.11g CH06 2437MHz - R	
1+2+3	Vertical	Fundamental
Peak	<p>Site : 03CH10-HY Condition : FCC CLASS-B 3m HORN 91200-HF VERTICAL Detector : Peak Project : 652049 Mode : 11 Setting : 14.5</p>	Left Blank
Avg.	<p>Site : 03CH10-HY Condition : FCC CLASS-B (AVG) 3m HORN 91200-HF VERTICAL Detector : Peak Project : 652049 Mode : 11 Setting : 14.5</p>	Left Blank

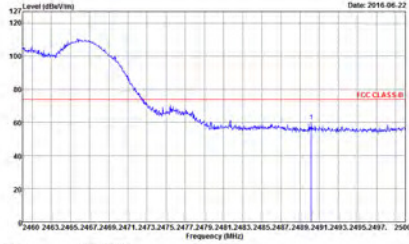
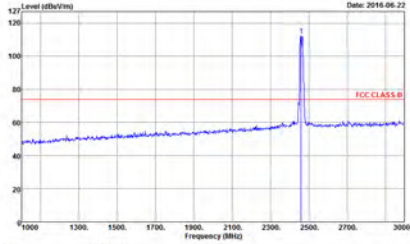
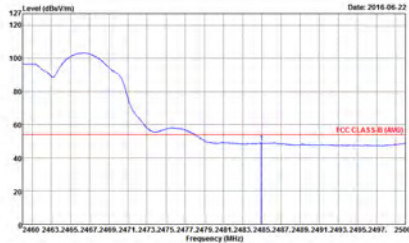
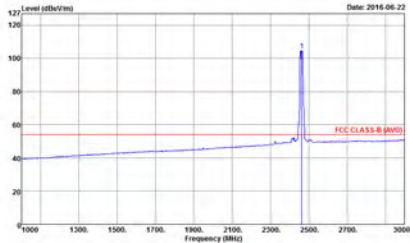

WIFI	2.4GHz 2400~2483.5MHz Band Edge @ 3m	
ANT	802.11g CH11 2462MHz	
1+2+3	Horizontal	Fundamental
Peak	 <p>Level (dBm/1m) vs Frequency (MHz) plot for Horizontal orientation. The y-axis ranges from 20 to 120 dBm/1m, and the x-axis ranges from 2460 to 2500 MHz. A blue line shows the spectrum, and a red horizontal line indicates the FCC CLASS B limit at approximately 75 dBm/1m. A sharp peak is visible at 2462 MHz.</p> <p>Site : 03CH10-HY Condition : FCC CLASS-B 3m HORN 91200-HF HORIZONTAL RBW:1000.000KHz VBW:3000.000KHz SWT:Auto Detector : Peak Project : 652049 Mode : 12</p>	 <p>Level (dBm/1m) vs Frequency (MHz) plot for Fundamental orientation. The y-axis ranges from 20 to 120 dBm/1m, and the x-axis ranges from 1000 to 3000 MHz. A blue line shows the spectrum, and a red horizontal line indicates the FCC CLASS B limit at approximately 75 dBm/1m. A sharp peak is visible at 2462 MHz.</p> <p>Site : 03CH10-HY Condition : FCC CLASS-B 3m HORN 91200-HF HORIZONTAL RBW:1000.000KHz VBW:3000.000KHz SWT:Auto Detector : Peak Project : 652049 Mode : 12</p>
Avg.	 <p>Level (dBm/1m) vs Frequency (MHz) plot for Horizontal orientation (Average). The y-axis ranges from 20 to 120 dBm/1m, and the x-axis ranges from 2460 to 2500 MHz. A blue line shows the average spectrum, and a red horizontal line indicates the FCC CLASS B (AVG) limit at approximately 55 dBm/1m.</p> <p>Site : 03CH10-HY Condition : FCC CLASS-B (AVG) 3m HORN 91200-HF HORIZONTAL RBW:1000.000KHz VBW:1.000KHz SWT:Auto Detector : Peak Project : 652049 Mode : 12</p>	 <p>Level (dBm/1m) vs Frequency (MHz) plot for Fundamental orientation (Average). The y-axis ranges from 20 to 120 dBm/1m, and the x-axis ranges from 1000 to 3000 MHz. A blue line shows the average spectrum, and a red horizontal line indicates the FCC CLASS B (AVG) limit at approximately 55 dBm/1m.</p> <p>Site : 03CH10-HY Condition : FCC CLASS-B (AVG) 3m HORN 91200-HF HORIZONTAL RBW:1000.000KHz VBW:1.000KHz SWT:Auto Detector : Peak Project : 652049 Mode : 12</p>



WIFI	2.4GHz 2400~2483.5MHz Band Edge @ 3m	
ANT	802.11g CH11 2462MHz	
1+2+3	Vertical	Fundamental
Peak	<p>Site : 03CH10-HY Condition : FCC CLASS-B 3m HORN 91200-HF VERTICAL RBW:1000.000KHz VBW:3000.000KHz SWT:Auto Detector : Peak Project : 652049 Mode : 12</p>	<p>Site : 03CH10-HY Condition : FCC CLASS-B 3m HORN 91200-HF VERTICAL RBW:1000.000KHz VBW:3000.000KHz SWT:Auto Detector : Peak Project : 652049 Mode : 12</p>
Avg.	<p>Site : 03CH10-HY Condition : FCC CLASS-B (AVG) 3m HORN 91200-HF VERTICAL RBW:1000.000KHz VBW:1.000KHz SWT:Auto Detector : Peak Project : 652049 Mode : 12</p>	<p>Site : 03CH10-HY Condition : FCC CLASS-B (AVG) 3m HORN 91200-HF VERTICAL RBW:1000.000KHz VBW:1.000KHz SWT:Auto Detector : Peak Project : 652049 Mode : 12</p>

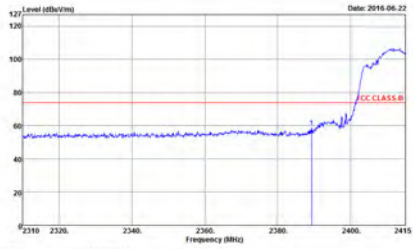
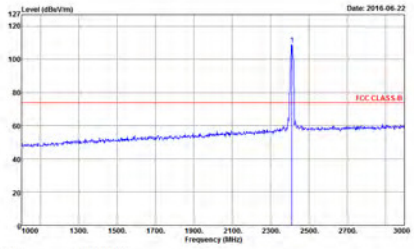
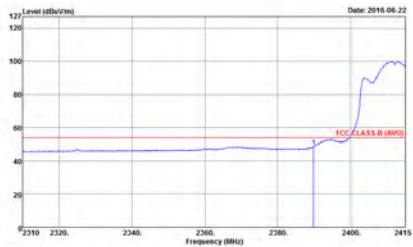
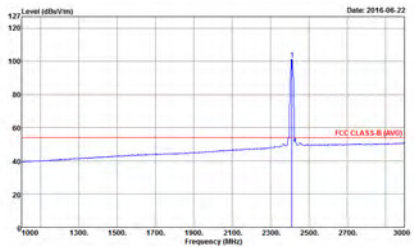

2.4GHz 2400~2483.5MHz
WIFI 802.11n HT20 (Band Edge @ 3m)

WIFI	2.4GHz 2400~2483.5MHz Band Edge @ 3m	
ANT	802.11n HT20 CH01 2412MHz	
1+2+3	Horizontal	Fundamental
Peak	 <p>Site : 03CH0-HY Condition : FCC CLASS-B 3m HORN 91200-HF HORIZONTAL RBW:1000.000kHz VBW:3000.000kHz SWT:Auto Detector : Peak Project : 052049 Mode : 13 Setting : 13.5</p>	 <p>Site : 03CH0-HY Condition : FCC CLASS-B 3m HORN 91200-HF HORIZONTAL RBW:1000.000kHz VBW:3000.000kHz SWT:Auto Detector : Peak Project : 052049 Mode : 13 Setting : 13.5</p>
Avg.	 <p>Site : 03CH0-HY Condition : FCC CLASS-B (AVG) 3m HORN 91200-HF HORIZONTAL RBW:1000.000kHz VBW:10000kHz SWT:Auto Detector : Peak Project : 052049 Mode : 13 Setting : 13.5</p>	 <p>Site : 03CH0-HY Condition : FCC CLASS-B (AVG) 3m HORN 91200-HF HORIZONTAL RBW:1000.000kHz VBW:10000kHz SWT:Auto Detector : Peak Project : 052049 Mode : 13 Setting : 13.5</p>

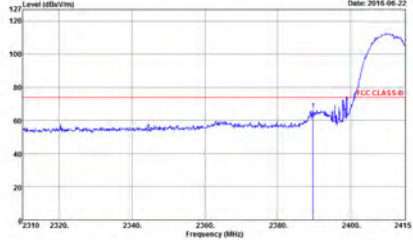
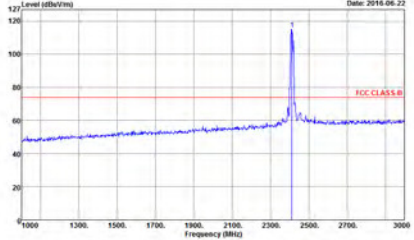
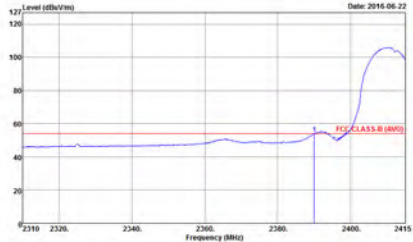
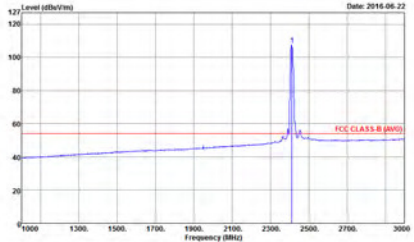

WIFI	2.4GHz 2400~2483.5MHz Band Edge @ 3m	
ANT	802.11n HT20 CH01 2412MHz	
1+2+3	Vertical	Fundamental
Peak	 <p>Site : 03CH10-HY Condition : FCC CLASS-B 3m HORN 91200-HF VERTICAL RBW:1000.000KHz VBW:3000.000KHz SWT:Auto Detector : Peak Project : 652049 Mode : 13 Setting : 13.5</p>	 <p>Site : 03CH10-HY Condition : FCC CLASS-B 3m HORN 91200-HF VERTICAL RBW:1000.000KHz VBW:3000.000KHz SWT:Auto Detector : Peak Project : 652049 Mode : 13 Setting : 13.5</p>
Avg.	 <p>Site : 03CH10-HY Condition : FCC CLASS-B (AVG) 3m HORN 91200-HF VERTICAL RBW:1000.000KHz VBW:1.000KHz SWT:Auto Detector : Peak Project : 652049 Mode : 13 Setting : 13.5</p>	 <p>Site : 03CH10-HY Condition : FCC CLASS-B (AVG) 3m HORN 91200-HF VERTICAL RBW:1000.000KHz VBW:1.000KHz SWT:Auto Detector : Peak Project : 652049 Mode : 13 Setting : 13.5</p>

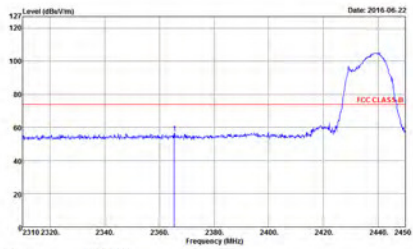
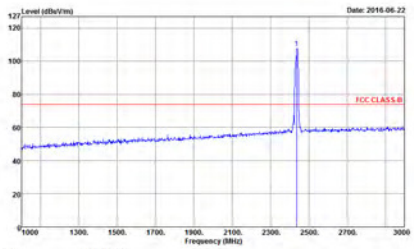
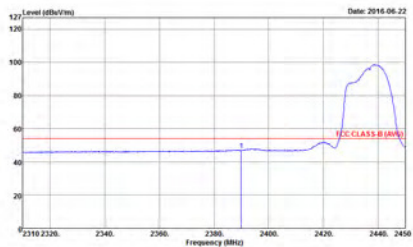
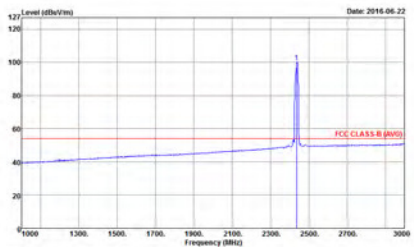

WIFI	2.4GHz 2400~2483.5MHz Band Edge @ 3m	
ANT	802.11n HT20 CH06 2437MHz - L	
1+2+3	Horizontal	Fundamental
Peak	 <p>Site : 03CH10-HY Condition : FCC CLASS-B 3m HORN 91200-HF HORIZONTAL RBW:1000.000KHz VBW:3000.000KHz SWT:Auto Detector : Peak Project : 652049 Mode : 14 Setting : 15.5</p>	 <p>Site : 03CH10-HY Condition : FCC CLASS-B 3m HORN 91200-HF HORIZONTAL RBW:1000.000KHz VBW:3000.000KHz SWT:Auto Detector : Peak Project : 652049 Mode : 14 Setting : 15.5</p>
Avg.	 <p>Site : 03CH10-HY Condition : FCC CLASS-B (AVG) 3m HORN 91200-HF HORIZONTAL RBW:1000.000KHz VBW:1.000KHz SWT:Auto Detector : Peak Project : 652049 Mode : 14 Setting : 15.5</p>	 <p>Site : 03CH10-HY Condition : FCC CLASS-B (AVG) 3m HORN 91200-HF HORIZONTAL RBW:1000.000KHz VBW:1.000KHz SWT:Auto Detector : Peak Project : 652049 Mode : 14 Setting : 15.5</p>

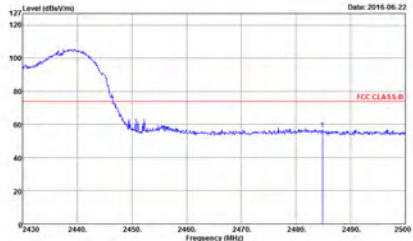
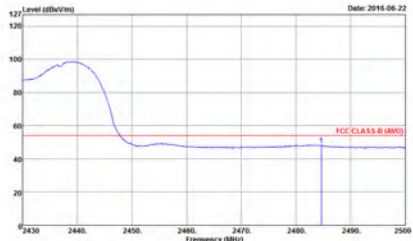

WIFI	2.4GHz 2400~2483.5MHz Band Edge @ 3m	
ANT	802.11n HT20 CH06 2437MHz - R	
1+2+3	Horizontal	Fundamental
<p>Peak</p>	 <p>Site : 03CH10-HY Condition : FCC CLASS-B 3m HORN 91200-HF HORIZONTAL RBW:1000.000KHz VBW:3000.000KHz SWT:Auto Detector : Peak Project : 652049 Mode : 14 Setting : 15.5</p>	<p>Left blank</p>
<p>Avg.</p>	 <p>Site : 03CH10-HY Condition : FCC CLASS-B (AVG) 3m HORN 91200-HF HORIZONTAL RBW:1000.000KHz VBW:1.000KHz SWT:Auto Detector : Peak Project : 652049 Mode : 14 Setting : 15.5</p>	<p>Left blank</p>



WIFI	2.4GHz 2400~2483.5MHz Band Edge @ 3m	
ANT	802.11n HT20 CH06 2437MHz - L	
1+2+3	Vertical	Fundamental
Peak	<p>Site : 03CH10-HY Condition : FCC CLASS-B 3m HORN 91200-HF VERTICAL RBW:1000.000KHz VBW:3000.000KHz SWT:Auto Detector : Peak Project : 652049 Mode : 14 Setting : 15.5</p>	<p>Site : 03CH10-HY Condition : FCC CLASS-B 3m HORN 91200-HF VERTICAL RBW:1000.000KHz VBW:3000.000KHz SWT:Auto Detector : Peak Project : 652049 Mode : 14 Setting : 15.5</p>
Avg.	<p>Site : 03CH10-HY Condition : FCC CLASS-B (AVG) 3m HORN 91200-HF VERTICAL RBW:1000.000KHz VBW:1.000KHz SWT:Auto Detector : Peak Project : 652049 Mode : 14 Setting : 15.5</p>	<p>Site : 03CH10-HY Condition : FCC CLASS-B (AVG) 3m HORN 91200-HF VERTICAL RBW:1000.000KHz VBW:1.000KHz SWT:Auto Detector : Peak Project : 652049 Mode : 14 Setting : 15.5</p>

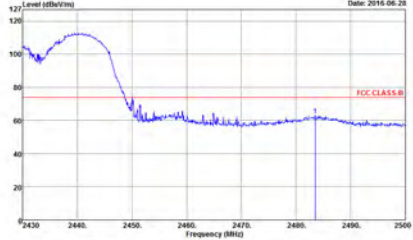
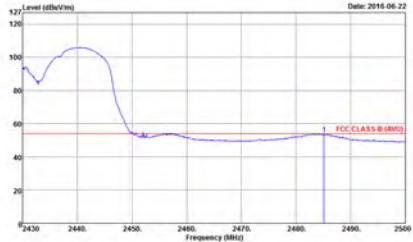

WIFI	2.4GHz 2400~2483.5MHz Band Edge @ 3m	
ANT	802.11n HT20 CH06 2437MHz - R	
1+2+3	Vertical	Fundamental
<p>Peak</p>	 <p>Site : 03CH10-HY Condition : FCC CLASS-B 3m HORN 91200-HF VERTICAL RBW:1000.000KHz VBW:3000.000KHz SWT:Auto Detector : Peak Project : 652049 Mode : 14 Setting : 15.5</p>	<p>Left Blank</p>
<p>Avg.</p>	 <p>Site : 03CH10-HY Condition : FCC CLASS-B (AVG) 3m HORN 91200-HF VERTICAL RBW:1000.000KHz VBW:1.000KHz SWT:Auto Detector : Peak Project : 652049 Mode : 14 Setting : 15.5</p>	<p>Left Blank</p>

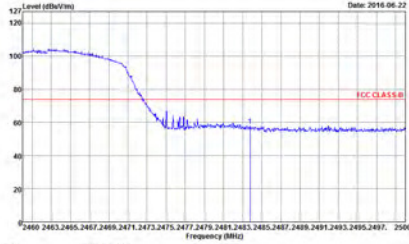
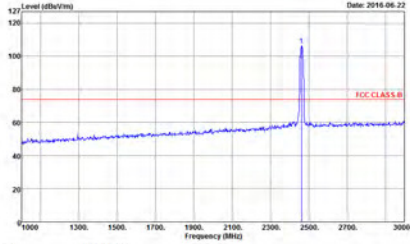
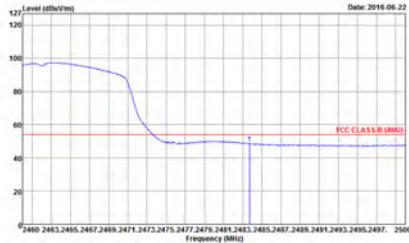
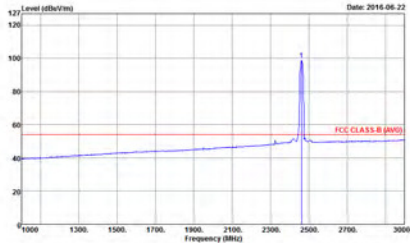

WIFI	2.4GHz 2400~2483.5MHz Band Edge @ 3m	
ANT	802.11n HT20 CH11 2462MHz	
1+2+3	Horizontal	Fundamental
Peak	 <p>Site : 03CH10-HY Condition : FCC CLASS-B 3m HORN 91200-HF HORIZONTAL RBW:1000.000KHz VBW:3000.000KHz SWT:Auto Detector : Peak Project : 652049 Mode : 15 Setting : 15.5</p>	 <p>Site : 03CH10-HY Condition : FCC CLASS-B 3m HORN 91200-HF HORIZONTAL RBW:1000.000KHz VBW:3000.000KHz SWT:Auto Detector : Peak Project : 652049 Mode : 15 Setting : 15.5</p>
Avg.	 <p>Site : 03CH10-HY Condition : FCC CLASS-B (AVG) 3m HORN 91200-HF HORIZONTAL RBW:1000.000KHz VBW:1.000KHz SWT:Auto Detector : Peak Project : 652049 Mode : 15 Setting : 15.5</p>	 <p>Site : 03CH10-HY Condition : FCC CLASS-B (AVG) 3m HORN 91200-HF HORIZONTAL RBW:1000.000KHz VBW:1.000KHz SWT:Auto Detector : Peak Project : 652049 Mode : 15 Setting : 15.5</p>

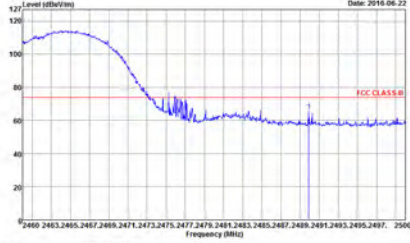
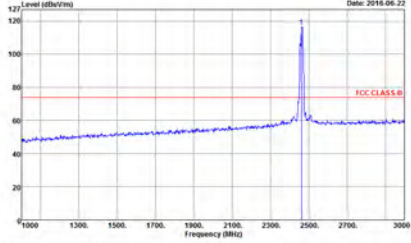
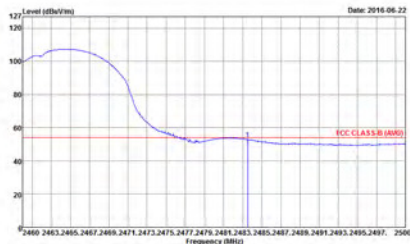
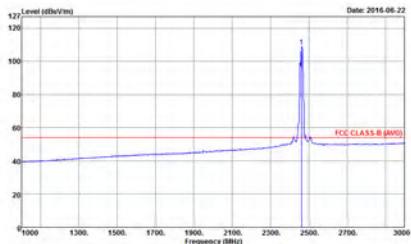

WIFI	2.4GHz 2400~2483.5MHz Fundamental @ 3m	
ANT	802.11n HT20 CH11 2462MHz	
1+2+3	Vertical	Fundamental
Peak	 <p>Site : 03CH10-HY Condition : FCC CLASS-B 3m HORN 91200-HF VERTICAL RBW:1000.000KHz VBW:3000.000KHz SWT:Auto Detector : Peak Project : 652049 Mode : 15 Setting : 15.5</p>	 <p>Site : 03CH10-HY Condition : FCC CLASS-B 3m HORN 91200-HF VERTICAL RBW:1000.000KHz VBW:3000.000KHz SWT:Auto Detector : Peak Project : 652049 Mode : 15 Setting : 15.5</p>
Avg.	 <p>Site : 03CH10-HY Condition : FCC CLASS-B (AVG) 3m HORN 91200-HF VERTICAL RBW:1000.000KHz VBW:1.000KHz SWT:Auto Detector : Peak Project : 652049 Mode : 15 Setting : 15.5</p>	 <p>Site : 03CH10-HY Condition : FCC CLASS-B (AVG) 3m HORN 91200-HF VERTICAL RBW:1000.000KHz VBW:1.000KHz SWT:Auto Detector : Peak Project : 652049 Mode : 15 Setting : 15.5</p>



2.4GHz 2400~2483.5MHz

WIFI 802.11n HT40 (Band Edge @ 3m)

WIFI	2.4GHz 2400~2483.5MHz Band Edge @ 3m	
ANT	802.11n HT40 CH03 2422MHz - L	
1+2+3	Horizontal	Fundamental
Peak	<p>Site : 03CH0-HY Condition : FCC CLASS-B 3m HORN 91200-HF HORIZONTAL Detector : Peak Project : 052049 Mode : 16 Setting : 10.5</p>	<p>Site : 03CH0-HY Condition : FCC CLASS-B 3m HORN 91200-HF HORIZONTAL Detector : Peak Project : 052049 Mode : 16 Setting : 10.5</p>
Avg.	<p>Site : 03CH0-HY Condition : FCC CLASS-B (AVG) 3m HORN 91200-HF HORIZONTAL Detector : Peak Project : 052049 Mode : 16 Setting : 10.5</p>	<p>Site : 03CH0-HY Condition : FCC CLASS-B (AVG) 3m HORN 91200-HF HORIZONTAL Detector : Peak Project : 052049 Mode : 16 Setting : 10.5</p>



WIFI	2.4GHz 2400~2483.5MHz Band Edge @ 3m	
ANT	802.11n HT40 CH03 2422MHz - R	
1+2+3	Horizontal	Fundamental
<p>Peak</p>	<p>Site : 03CH10-HY Condition : FCC CLASS-B 3m HORN 91200-HF HORIZONTAL RBW:1000.000KHz VBW:3000.000KHz SWT:Auto Detector : Peak Project : 652049 Mode : 16 Setting : 10.5</p>	<p>Left Blank</p>
<p>Avg.</p>	<p>Site : 03CH10-HY Condition : FCC CLASS-B (AVG) 3m HORN 91200-HF HORIZONTAL RBW:1000.000KHz VBW:3.000KHz SWT:Auto Detector : Peak Project : 652049 Mode : 16 Setting : 10.5</p>	<p>Left Blank</p>

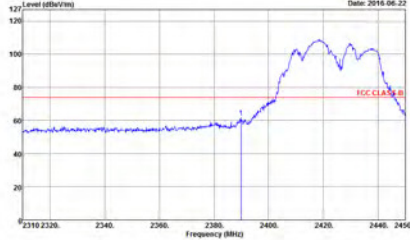
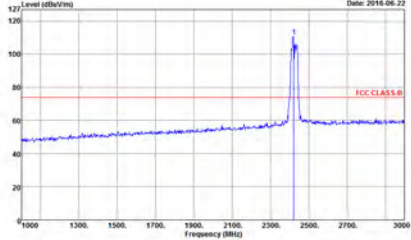
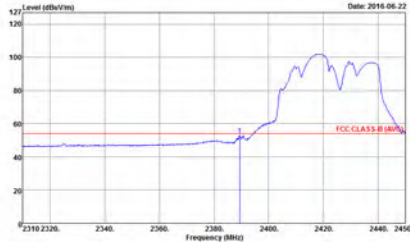
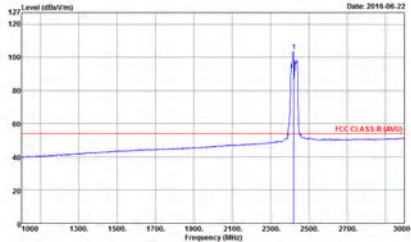

WIFI	2.4GHz 2400~2483.5MHz Band Edge @ 3m	
ANT	802.11n HT40 CH03 2422MHz - L	
1+2+3	Vertical	Fundamental
Peak	 <p>Site : 03CH10-HY Condition : FCC CLASS-B 3m HORN 91200-HF VERTICAL RBW:1000.000KHz VBW:3000.000KHz SWT:Auto Detector : Peak Project : 652049 Mode : 16 Setting : 10.5</p>	 <p>Site : 03CH10-HY Condition : FCC CLASS-B 3m HORN 91200-HF VERTICAL RBW:1000.000KHz VBW:3000.000KHz SWT:Auto Detector : Peak Project : 652049 Mode : 16 Setting : 10.5</p>
Avg.	 <p>Site : 03CH10-HY Condition : FCC CLASS-B (AVG) 3m HORN 91200-HF VERTICAL RBW:1000.000KHz VBW:3.000KHz SWT:Auto Detector : Peak Project : 652049 Mode : 16 Setting : 10.5</p>	 <p>Site : 03CH10-HY Condition : FCC CLASS-B (AVG) 3m HORN 91200-HF VERTICAL RBW:1000.000KHz VBW:3.000KHz SWT:Auto Detector : Peak Project : 652049 Mode : 16 Setting : 10.5</p>



WIFI	2.4GHz 2400~2483.5MHz Band Edge @ 3m	
ANT	802.11n HT40 CH03 2422MHz - R	
1+2+3	Vertical	Fundamental
<p>Peak</p>	<p>Site : 03CH10-HY Condition : FCC CLASS-B 3m HORN 91200-HF VERTICAL RBW:1000.000KHz VBW:3000.000KHz SWT:Auto Detector : Peak Project : 652049 Mode : 16 Setting : 10.5</p>	<p>Left blank</p>
<p>Avg.</p>	<p>Site : 03CH10-HY Condition : FCC CLASS-B (AVG) 3m HORN 91200-HF VERTICAL RBW:1000.000KHz VBW:3.000KHz SWT:Auto Detector : Peak Project : 652049 Mode : 16 Setting : 10.5</p>	<p>Left blank</p>

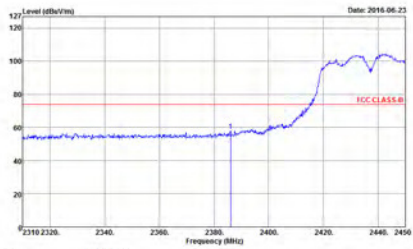
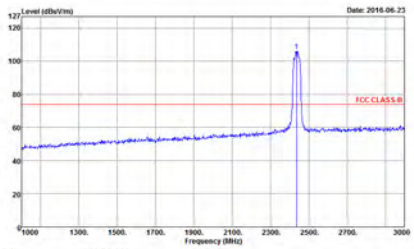
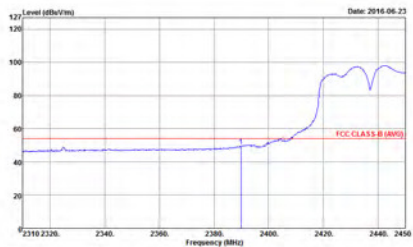
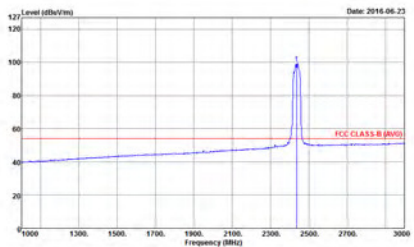

WIFI	2.4GHz 2400~2483.5MHz Band Edge @ 3m	
ANT	802.11n HT40 CH06 2437MHz - L	
1+2+3	Horizontal	Fundamental
Peak	 <p>Site : 03CH10-HY Condition : FCC CLASS-B 3m HORN 91200-HF HORIZONTAL RBW:1000.000KHz VBW:3000.000KHz SWT:Auto Detector : Peak Project : 652049 Mode : 17 Setting : 16.5</p>	 <p>Site : 03CH10-HY Condition : FCC CLASS-B 3m HORN 91200-HF HORIZONTAL RBW:1000.000KHz VBW:3000.000KHz SWT:Auto Detector : Peak Project : 652049 Mode : 17 Setting : 16.5</p>
Avg.	 <p>Site : 03CH10-HY Condition : FCC CLASS-B (AVG) 3m HORN 91200-HF HORIZONTAL RBW:1000.000KHz VBW:3.000KHz SWT:Auto Detector : Peak Project : 652049 Mode : 17 Setting : 16.5</p>	 <p>Site : 03CH10-HY Condition : FCC CLASS-B (AVG) 3m HORN 91200-HF HORIZONTAL RBW:1000.000KHz VBW:3.000KHz SWT:Auto Detector : Peak Project : 652049 Mode : 17 Setting : 16.5</p>

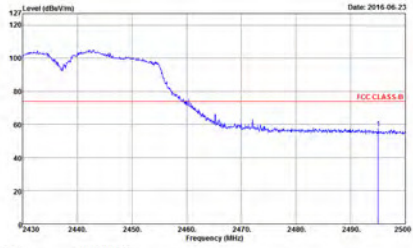
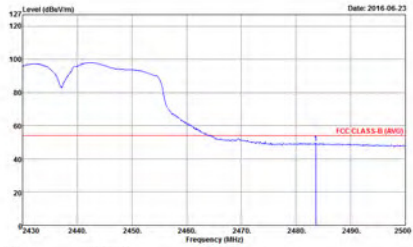

WIFI	2.4GHz 2400~2483.5MHz Band Edge @ 3m	
ANT	802.11n HT40 CH06 2437MHz - R	
1+2+3	Horizontal	Fundamental
<p>Peak</p>	 <p>Site : 03CH10-HY Condition : FCC CLASS-B 3m HORN 91200-HF HORIZONTAL RBW:1000.000KHz VBW:3000.000KHz SWT:Auto Detector : Peak Project : 652049 Mode : 17 Setting : 16.5</p>	<p>Left blank</p>
<p>Avg.</p>	 <p>Site : 03CH10-HY Condition : FCC CLASS-B (AVG) 3m HORN 91200-HF HORIZONTAL RBW:1000.000KHz VBW:3.000KHz SWT:Auto Detector : Peak Project : 652049 Mode : 17 Setting : 16.5</p>	<p>Left blank</p>



WIFI	2.4GHz 2400~2483.5MHz Band Edge @ 3m	
ANT	802.11n HT40 CH06 2437MHz - L	
1+2+3	Vertical	Fundamental
Peak	<p>Site : 03CH10-HY Condition : FCC CLASS-B 3m HORN 91200-HF VERTICAL RBW:1000.000KHz VBW:3000.000KHz SWT:Auto Detector : Peak Project : 652049 Mode : 17 Setting : 16.5</p>	<p>Site : 03CH10-HY Condition : FCC CLASS-B 3m HORN 91200-HF VERTICAL RBW:1000.000KHz VBW:3000.000KHz SWT:Auto Detector : Peak Project : 652049 Mode : 17 Setting : 16.5</p>
Avg.	<p>Site : 03CH10-HY Condition : FCC CLASS-B (AVG) 3m HORN 91200-HF VERTICAL RBW:1000.000KHz VBW:3.000KHz SWT:Auto Detector : Peak Project : 652049 Mode : 17 Setting : 16.5</p>	<p>Site : 03CH10-HY Condition : FCC CLASS-B (AVG) 3m HORN 91200-HF VERTICAL RBW:1000.000KHz VBW:3.000KHz SWT:Auto Detector : Peak Project : 652049 Mode : 17 Setting : 16.5</p>

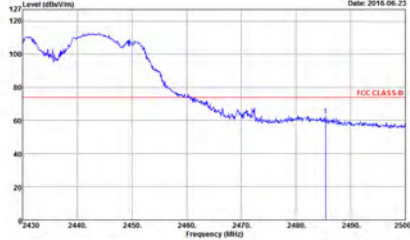
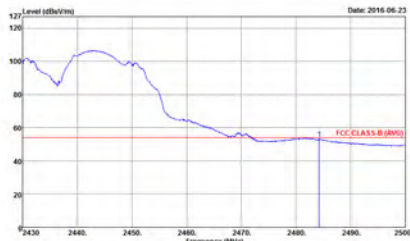

WIFI	2.4GHz 2400~2483.5MHz Band Edge @ 3m	
ANT	802.11n HT40 CH06 2437MHz - R	
1+2+3	Vertical	Fundamental
<p>Peak</p>	 <p>Site : 03CH10-HY Condition : FCC CLASS-B 3m HORN 91200-HF VERTICAL RBW:1000.000KHz VBW:3000.000KHz SWT:Auto Detector : Peak Project : 652049 Mode : 17 Setting : 16.5</p>	<p>Left blank</p>
<p>Avg.</p>	 <p>Site : 03CH10-HY Condition : FCC CLASS-B (AVG) 3m HORN 91200-HF VERTICAL RBW:1000.000KHz VBW:3.000KHz SWT:Auto Detector : Peak Project : 652049 Mode : 17 Setting : 16.5</p>	<p>Left blank</p>

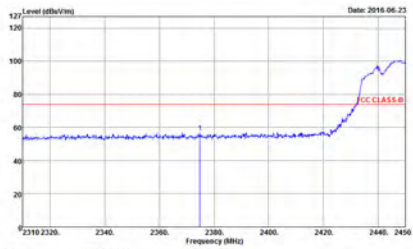
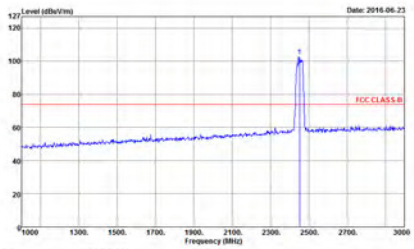
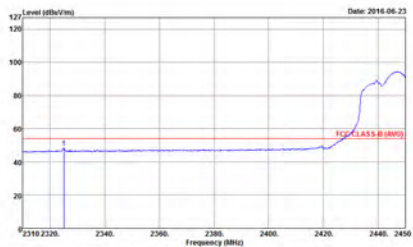
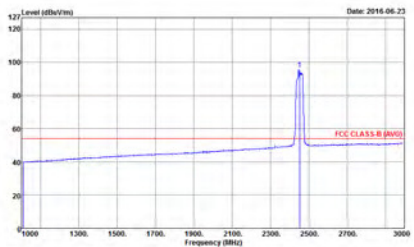

WIFI	2.4GHz 2400~2483.5MHz Band Edge @ 3m	
ANT	802.11n HT40 CH09 2452MHz - L	
1+2+3	Horizontal	Fundamental
Peak	 <p>Site : 03CH10-HY Condition : FCC CLASS-B 3m HORN 91200-HF HORIZONTAL RBW:1000.000KHz VBW:3000.000KHz SWT:Auto Detector : Peak Project : 652049 Mode : 1B Setting : 12.5</p>	 <p>Site : 03CH10-HY Condition : FCC CLASS-B 3m HORN 91200-HF HORIZONTAL RBW:1000.000KHz VBW:3000.000KHz SWT:Auto Detector : Peak Project : 652049 Mode : 1B Setting : 12.5</p>
Avg.	 <p>Site : 03CH10-HY Condition : FCC CLASS-B (AVG) 3m HORN 91200-HF HORIZONTAL RBW:1000.000KHz VBW:3.000KHz SWT:Auto Detector : Peak Project : 652049 Mode : 1B Setting : 12.5</p>	 <p>Site : 03CH10-HY Condition : FCC CLASS-B (AVG) 3m HORN 91200-HF HORIZONTAL RBW:1000.000KHz VBW:3.000KHz SWT:Auto Detector : Peak Project : 652049 Mode : 1B Setting : 12.5</p>

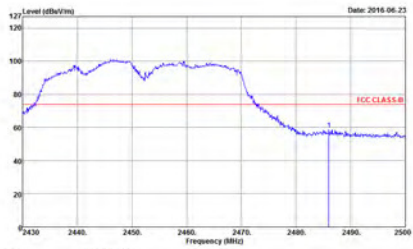
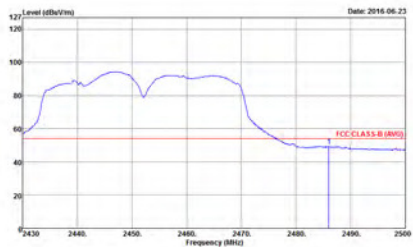

WIFI	2.4GHz 2400~2483.5MHz Band Edge @ 3m	
ANT	802.11n HT40 CH09 2452MHz - R	
1+2+3	Horizontal	Fundamental
Peak	 <p>Site : 03CH10-HY Condition : FCC CLASS-B 3m HORN 91200-HF HORIZONTAL RBW:1000.000kHz VBW:3000.000kHz SWT:Auto Detector : Peak Project : 652049 Mode : 18 Setting : 12.5</p>	Left blank
Avg.	 <p>Site : 03CH10-HY Condition : FCC CLASS-B (AVG) 3m HORN 91200-HF HORIZONTAL RBW:1000.000kHz VBW:3.000kHz SWT:Auto Detector : Peak Project : 652049 Mode : 18 Setting : 12.5</p>	Left blank

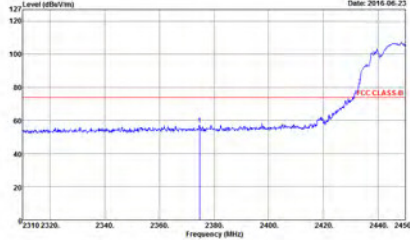
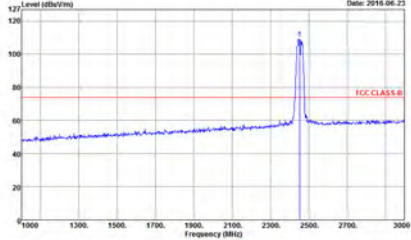
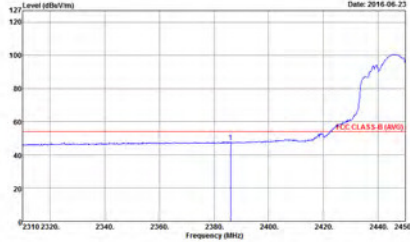
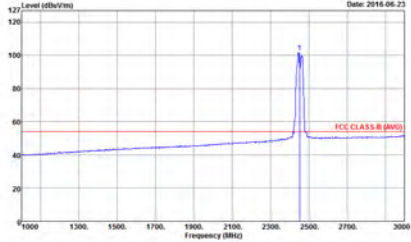

WIFI	2.4GHz 2400~2483.5MHz Band Edge @ 3m	
ANT	802.11n HT40 CH09 2452MHz - L	
1+2+3	Vertical	Fundamental
Peak	 <p>Site : 03CH10-HY Condition : FCC CLASS-B 3m HORN 91200-HF VERTICAL RBW:1000.000KHz VBW:3000.000KHz SWT:Auto Detector : Peak Project : 652049 Mode : 1B Setting : 12.5</p>	 <p>Site : 03CH10-HY Condition : FCC CLASS-B 3m HORN 91200-HF VERTICAL RBW:1000.000KHz VBW:3000.000KHz SWT:Auto Detector : Peak Project : 652049 Mode : 1B Setting : 12.5</p>
Avg.	 <p>Site : 03CH10-HY Condition : FCC CLASS-B (AVG) 3m HORN 91200-HF VERTICAL RBW:1000.000KHz VBW:3.000KHz SWT:Auto Detector : Peak Project : 652049 Mode : 1B Setting : 12.5</p>	 <p>Site : 03CH10-HY Condition : FCC CLASS-B (AVG) 3m HORN 91200-HF VERTICAL RBW:1000.000KHz VBW:3.000KHz SWT:Auto Detector : Peak Project : 652049 Mode : 1B Setting : 12.5</p>

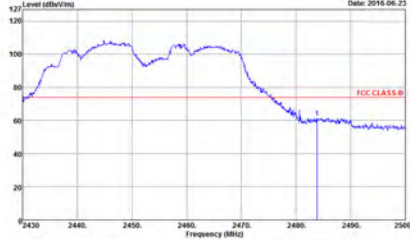
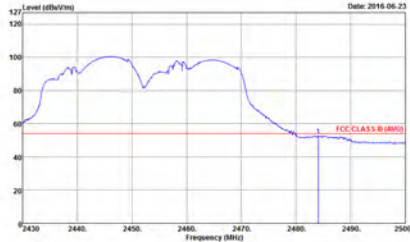

WIFI	2.4GHz 2400~2483.5MHz Band Edge @ 3m	
ANT	802.11n HT40 CH09 2452MHz - R	
1+2+3	Vertical	Fundamental
<p>Peak</p>	 <p>Site : 03CH10-HY Condition : FCC CLASS-B 3m HORN 91200-HF VERTICAL RBW:1000.000KHz VBW:3000.000KHz SWT:Auto Detector : Peak Project : 652049 Mode : 1B Setting : 12.5</p>	<p>Left blank</p>
<p>Avg.</p>	 <p>Site : 03CH10-HY Condition : FCC CLASS-B (AVG) 3m HORN 91200-HF VERTICAL RBW:1000.000KHz VBW:3.000KHz SWT:Auto Detector : Peak Project : 652049 Mode : 1B Setting : 12.5</p>	<p>Left blank</p>



2.4GHz 2400~2483.5MHz
WIFI 802.11b (Harmonic @ 3m)

Table with 2 columns: Horizontal and Vertical. Each column contains a spectrum plot showing Level (dBm/100m) vs Frequency (MHz) with FCC CLASS B and FCC CLASS B (MURS) limits. Includes metadata like Site, Condition, Detector, Project, and Mode.



WIFI	2.4GHz 2400~2483.5MHz Harmonic @ 3m	
ANT	802.11b CH06 2437MHz	
1+2+3	Horizontal	Vertical
Peak Avg.	<p>Site : 03CH10-HY Condition : FCC CLASS-B 3m HORN_9170_406_0584 HORIZONTAL Detector : Peak Project : 852049 Mode : B</p>	<p>Site : 03CH10-HY Condition : FCC CLASS-B 3m HORN_9170_406_0584 VERTICAL Detector : Peak Project : 852049 Mode : B</p>



WIFI	2.4GHz 2400~2483.5MHz Harmonic @ 3m	
ANT	802.11b CH11 2462MHz	
1+2+3	Horizontal	Vertical
Peak Avg.	<p>Site : 03CH10-HY Condition : FCC CLASS-B 3m HORN_9170_406_0584 HORIZONTAL Detector : Peak Project : 852049 Mode : 9</p>	<p>Site : 03CH10-HY Condition : FCC CLASS-B 3m HORN_9170_406_0584 VERTICAL Detector : Peak Project : 852049 Mode : 9</p>



2.4GHz 2400~2483.5MHz
WIFI 802.11g (Harmonic @ 3m)

Table with 2 columns: Horizontal and Vertical. Each column contains a graph of Level (dBm) vs Frequency (MHz) and associated test parameters like Site, Condition, Detector, Project, and Mode.

Peak Avg.



WIFI	2.4GHz 2400~2483.5MHz Harmonic @ 3m	
ANT	802.11g CH06 2437MHz	
1+2+3	Horizontal	Vertical
Peak Avg.	<p>Site : 03CH10-HY Condition : FCC CLASS-B 3m HORN_9170_406_0584 HORIZONTAL Detector : Peak Project : 652049 Mode : 11</p>	<p>Site : 03CH10-HY Condition : FCC CLASS-B 3m HORN_9170_406_0584 VERTICAL Detector : Peak Project : 652049 Mode : 11</p>



WIFI	2.4GHz 2400~2483.5MHz Harmonic @ 3m	
ANT	802.11g CH11 2462MHz	
1+2+3	Horizontal	Vertical
Peak Avg.	<p>Site : 03CH10-HY Condition : FCC CLASS-B 3m HORN_9170_406_0584 HORIZONTAL Detector : Peak Project : 652049 Mode : 12</p>	<p>Site : 03CH10-HY Condition : FCC CLASS-B 3m HORN_9170_406_0584 VERTICAL Detector : Peak Project : 652049 Mode : 12</p>

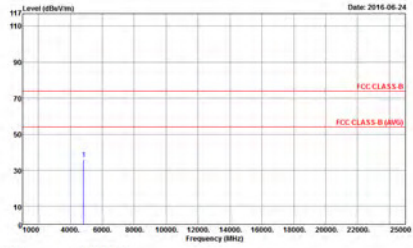
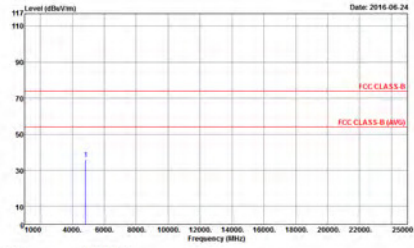

2.4GHz 2400~2483.5MHz
 WIFI 802.11n HT20 (Harmonic @ 3m)

WIFI	2.4GHz 2400~2483.5MHz Harmonic @ 3m	
ANT	802.11n HT20 CH01 2412MHz	
1+2+3	Horizontal	Vertical
<p>Peak Avg.</p>	 <p>Site : 03CH10-HY Condition : FCC CLASS-B 3m HORN_9170_406_0584 HORIZONTAL Detector : Peak Project : 652049 Mode : 13</p>	 <p>Site : 03CH10-HY Condition : FCC CLASS-B 3m HORN_9170_406_0584 VERTICAL Detector : Peak Project : 652049 Mode : 13</p>



WIFI	2.4GHz 2400~2483.5MHz Harmonic @ 3m	
ANT	802.11n HT20 CH06 2437MHz	
1+2+3	Horizontal	Vertical
Peak Avg.	<p>Site : 03CH10-HY Condition : FCC CLASS-B 3m HORN_9170_406_0584 HORIZONTAL Detector : Peak Project : 652049 Mode : 14</p>	<p>Site : 03CH10-HY Condition : FCC CLASS-B 3m HORN_9170_406_0584 VERTICAL Detector : Peak Project : 652049 Mode : 14</p>

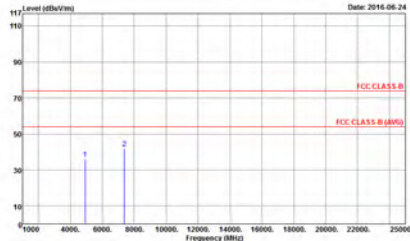
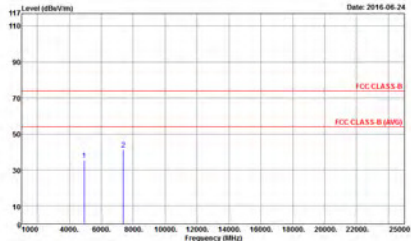

WIFI	2.4GHz 2400~2483.5MHz Harmonic @ 3m	
ANT	802.11n HT20 CH11 2462MHz	
1+2+3	Horizontal	Vertical
Peak Avg.	 <p>Site : 03CH10-HY Condition : FCC CLASS-B 3m HORN_9170_406_0584 HORIZONTAL Detector : Peak Project : 652049 Mode : IS</p>	 <p>Site : 03CH10-HY Condition : FCC CLASS-B 3m HORN_9170_406_0584 VERTICAL Detector : Peak Project : 652049 Mode : IS</p>

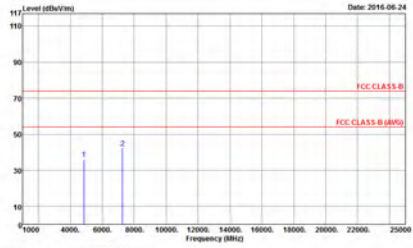
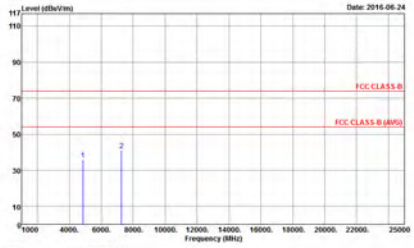

2.4GHz 2400~2483.5MHz
WIFI 802.11n HT40 (Harmonic @ 3m)

WIFI	2.4GHz 2400~2483.5MHz Harmonic @ 3m	
ANT	802.11n HT40 CH03 2422MHz	
1+2+3	Horizontal	Vertical
Peak Avg.	 <p>Site : 03CH10-HY Condition : FCC CLASS-B 3m HORN_9170_406_0584 HORIZONTAL Detector : Peak Project : 652049 Mode : 10</p>	 <p>Site : 03CH10-HY Condition : FCC CLASS-B 3m HORN_9170_406_0584 VERTICAL Detector : Peak Project : 652049 Mode : 10</p>



WIFI	2.4GHz 2400~2483.5MHz Harmonic @ 3m	
ANT	802.11n HT40 CH06 2437MHz	
1+2+3	Horizontal	Vertical
Peak Avg.	<p>Site : 03CH10-HY Condition : FCC CLASS-B 3m HORN_9170_406_0584 HORIZONTAL Detector : Peak Project : 652049 Mode : 17</p>	<p>Site : 03CH10-HY Condition : FCC CLASS-B 3m HORN_9170_406_0584 VERTICAL Detector : Peak Project : 652049 Mode : 17</p>

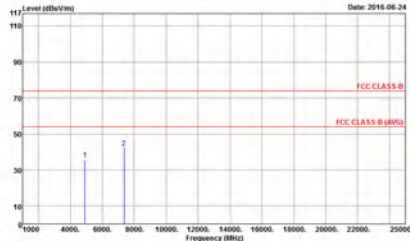
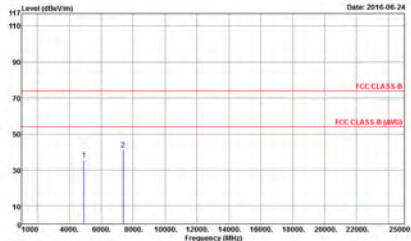

WIFI	2.4GHz 2400~2483.5MHz Harmonic @ 3m	
ANT	802.11n HT40 CH09 2452MHz	
1+2+3	Horizontal	Vertical
Peak Avg.	 <p>Site : 03CH10-HY Condition : FCC CLASS-B 3m HORN_9170_406_0584 HORIZONTAL Detector : Peak Project : 852049 Mode : 1B</p>	 <p>Site : 03CH10-HY Condition : FCC CLASS-B 3m HORN_9170_406_0584 VERTICAL Detector : Peak Project : 852049 Mode : 1B</p>



Emission below 1GHz
2.4GHz WIFI 802.11b (LF)

Table with 2 columns: Horizontal and Vertical. Each column contains a graph of Level (dBm/1m) vs Frequency (MHz) for 2.4GHz 2400~2483.5MHz. Includes metadata like Site, Condition, Detector, Project, and Mode.



2.4GHz 2400~2483.5MHz

Emission below 1GHz

2.4GHz WIFI 802.11g (LF)

WIFI	2.4GHz 2400~2483.5MHz	
ANT	802.11g LF	
1+2+3	Horizontal	Vertical
QP / Peak	<p>Site : 03CH10-HY Condition : FCC CLASS-B 3m BI-LOG 6111D-LF HORIZONTAL Detector : Peak Project : 652049 Mode : 20</p>	<p>Site : 03CH10-HY Condition : FCC CLASS-B 3m BI-LOG 6111D-LF VERTICAL Detector : Peak Project : 652049 Mode : 20</p>



2.4GHz 2400~2483.5MHz

Emission below 1GHz

2.4GHz WIFI 802.11n HT20 (LF)

WIFI	2.4GHz 2400~2483.5MHz	
ANT	802.11n HT20 LF	
1+2+3	Horizontal	Vertical
QP / Peak	<p>Site : 03CH10-HY Condition : FCC CLASS-B 3m BT-LOG 6111D-LF HORIZONTAL Detector : Peak Project : 652049 Mode : 21</p>	<p>Site : 03CH10-HY Condition : FCC CLASS-B 3m BT-LOG 6111D-LF VERTICAL Detector : Peak Project : 652049 Mode : 21</p>



2.4GHz 2400~2483.5MHz

Emission below 1GHz

2.4GHz WIFI 802.11n HT40 (LF)

WIFI	2.4GHz 2400~2483.5MHz	
ANT	802.11n HT40 LF	
1+2+3	Horizontal	Vertical
QP / Peak	<p>Site : 03CH10-HY Condition : FCC CLASS-B 3m BI-LOG 6111D-LF HORIZONTAL Detector : Peak Project : 652049 Mode : 22</p>	<p>Site : 03CH10-HY Condition : FCC CLASS-B 3m BI-LOG 6111D-LF VERTICAL Detector : Peak Project : 652049 Mode : 22</p>



Appendix D. Duty Cycle Plots

Antenna	Band	Duty Cycle(%)	T(us)	1/T(kHz)	VBW Setting
1+2+3	802.11b for Ant 1	100	-	-	10Hz
1+2+3	802.11b for Ant 2	100	-	-	10Hz
1+2+3	802.11b for Ant 3	100	-	-	10Hz
1+2+3	802.11g for Ant 1	97.12	2020	0.50	1kHz
1+2+3	802.11g for Ant 2	97.12	2020	0.50	1kHz
1+2+3	802.11g for Ant 3	97.12	2020	0.50	1kHz
1+2+3	2.4GHz 802.11n HT20 for Ant 1	96.72	1888	0.53	1kHz
1+2+3	2.4GHz 802.11n HT20 for Ant 2	97.52	1888	0.53	1kHz
1+2+3	2.4GHz 802.11n HT20 for Ant 3	97.53	1896	0.53	1kHz
1+2+3	2.4GHz 802.11n HT40 for Ant 1	94.99	930	1.08	3kHz
1+2+3	2.4GHz 802.11n HT40 for Ant 2	95.88	930	1.08	3kHz
1+2+3	2.4GHz 802.11n HT40 for Ant 3	94.85	920	1.09	3kHz



<MIMO Ant. 1+2+3(1)>

802.11b

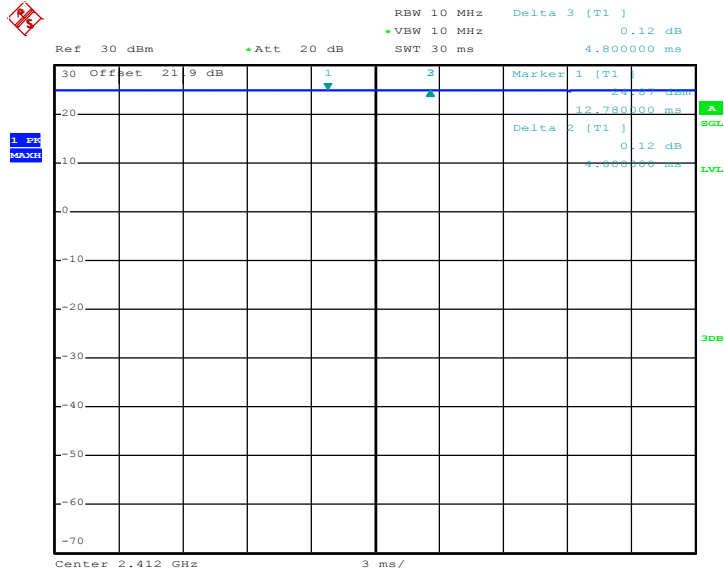

Date: 27.MAY.2016 22:00:21

802.11g

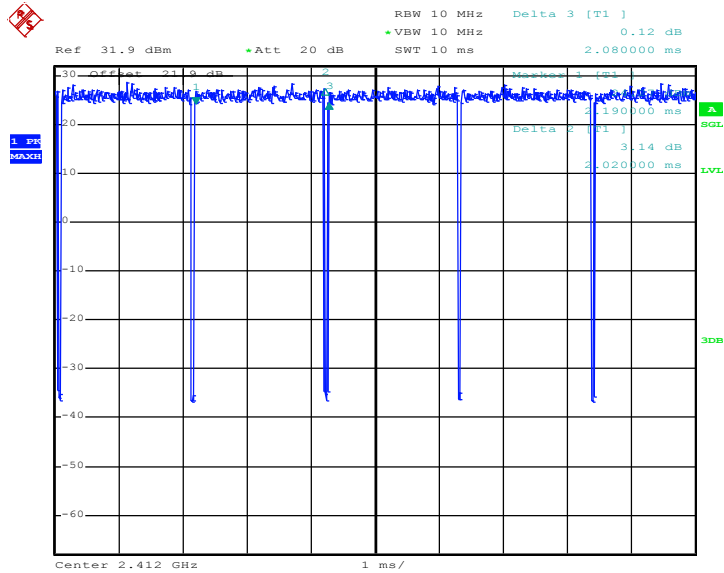

Date: 27.MAY.2016 22:53:15



802.11n HT20

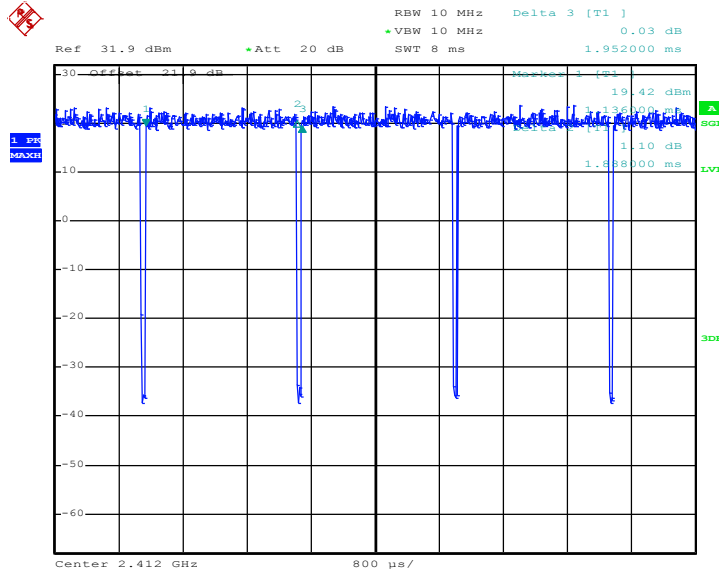

Date: 27.MAY.2016 23:57:03

802.11n HT40

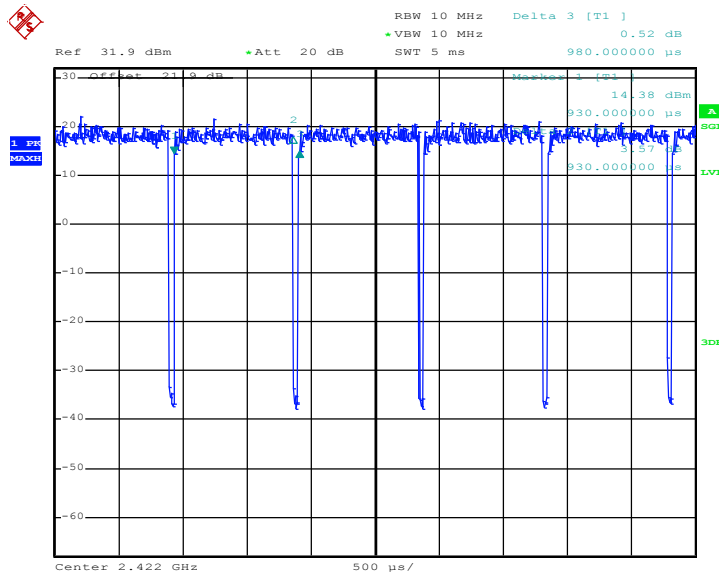

Date: 28.MAY.2016 00:20:41



<MIMO Ant. 1+2+3(2)>

802.11b

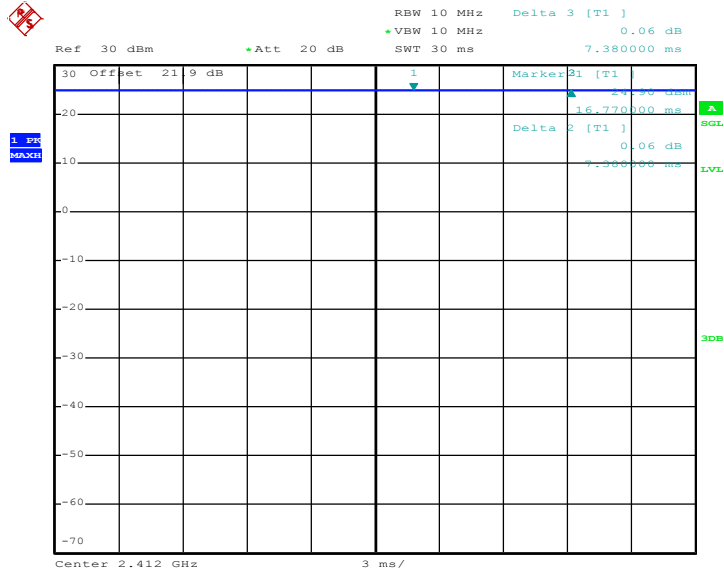

Date: 27.MAY.2016 22:01:36

802.11g

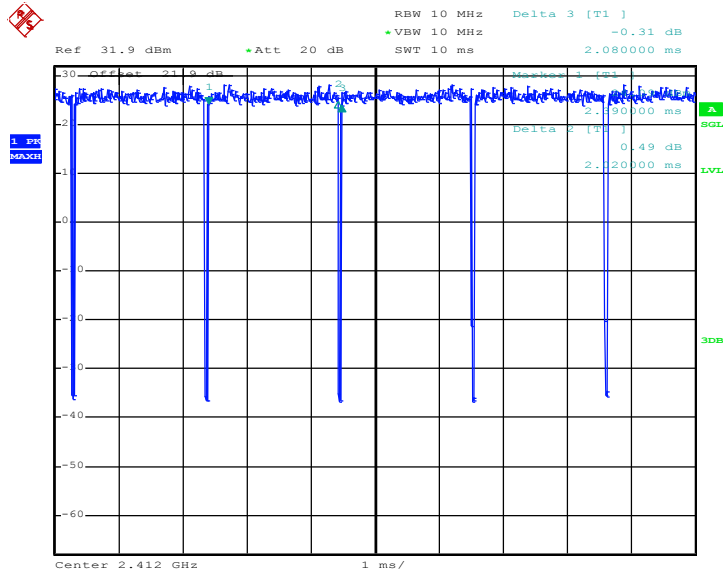

Date: 27.MAY.2016 23:27:10



802.11n HT20

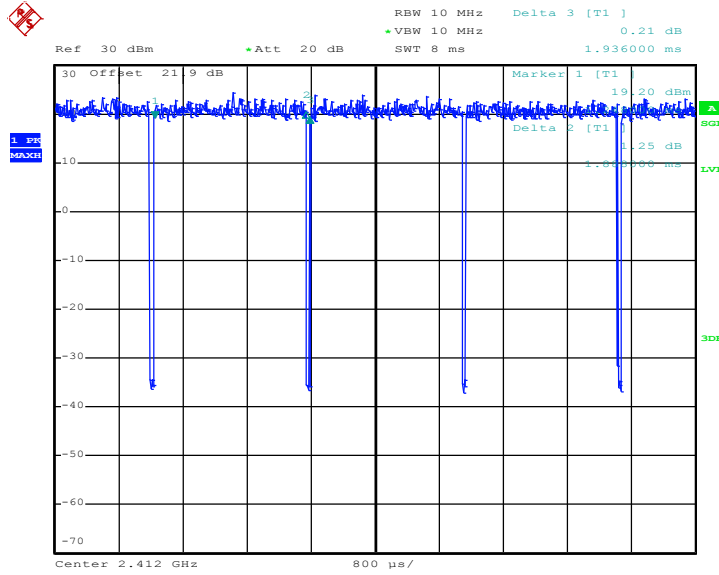

Date: 27.MAY.2016 23:58:20

802.11n HT40

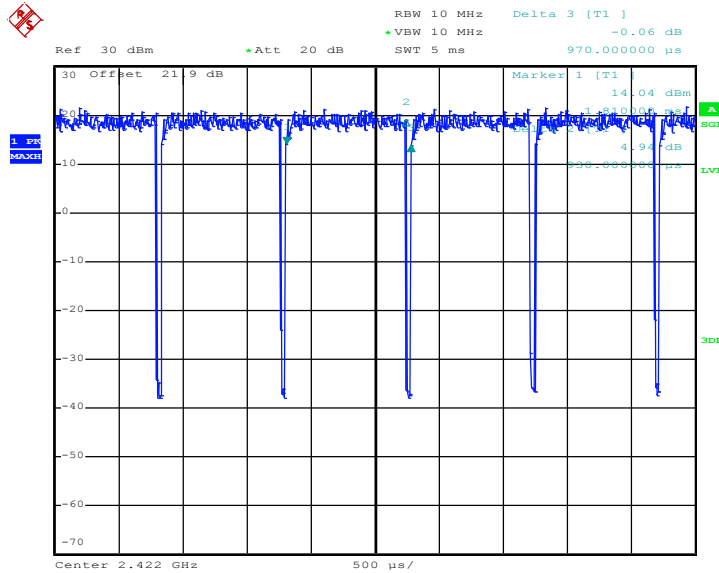

Date: 28.MAY.2016 00:24:17



<MIMO Ant. 1+2+3(3)>

802.11b

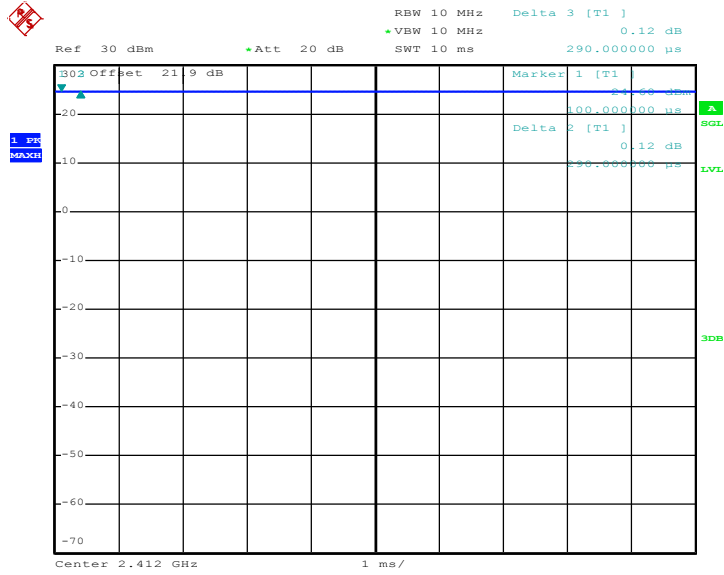

Date: 27.MAY.2016 22:02:59

802.11g

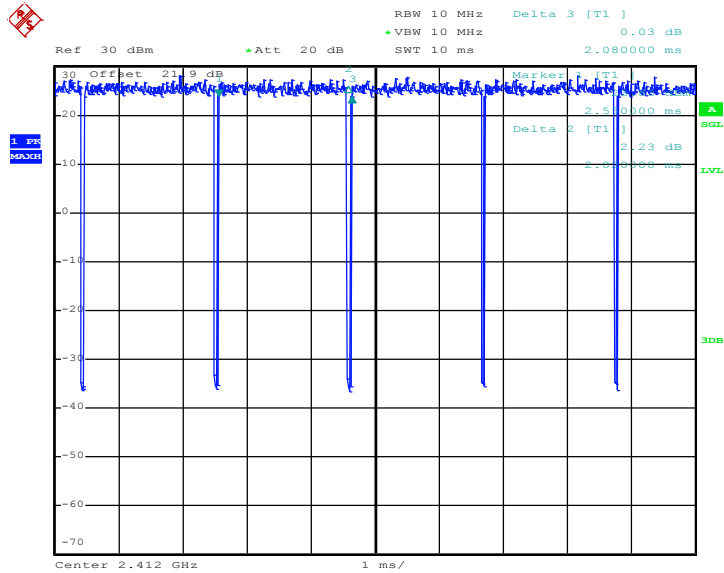

Date: 27.MAY.2016 23:28:23



802.11n HT20

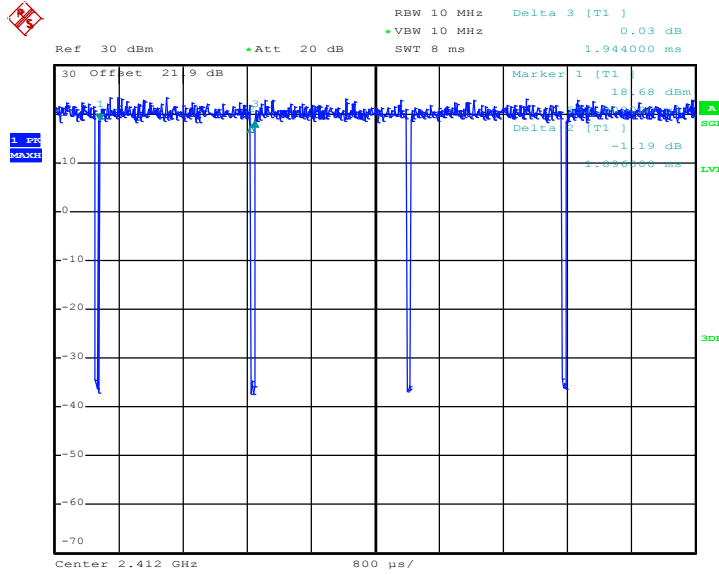

Date: 28.MAY.2016 00:00:23

802.11n HT40

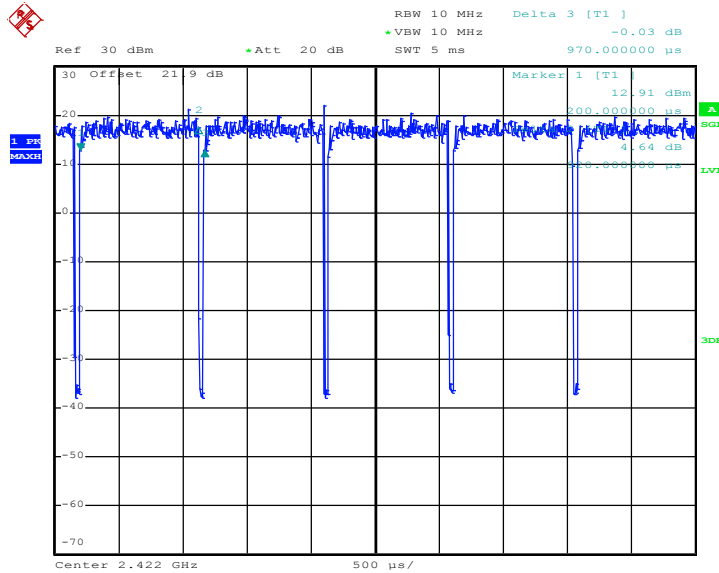

Date: 28.MAY.2016 00:25:21