



FCC RF Test Report

APPLICANT : Ignition Design Labs (US) LLC
EQUIPMENT : Advanced Wireless Router
BRAND NAME : Ignition Design Labs
MODEL NAME : Portal
MARKETING NAME : Portal
FCC ID : 2AFZUSAP102
STANDARD : FCC Part 15 Subpart E §15.407
CLASSIFICATION : (NII) Unlicensed National Information Infrastructure

The product was received on May 20, 2016 and testing was completed on Jul. 14, 2016. We, SPORTON INTERNATIONAL INC., would like to declare that the tested sample has been evaluated in accordance with the test procedures and has been in compliance with the applicable technical standards.

The test results in this report apply exclusively to the tested model / sample. Without written approval of SPORTON INTERNATIONAL INC., the test report shall not be reproduced except in full.

Reviewed by: Joseph Lin / Supervisor

Approved by: Jones Tsai / Manager



SPORTON INTERNATIONAL INC.

No. 52, Hwa Ya 1st Rd., Hwa Ya Technology Park, Kwei-Shan District, Tao Yuan City, Taiwan, R.O.C.

SPORTON INTERNATIONAL INC.

TEL : 886-3-327-3456

FAX : 886-3-328-4978

FCC ID : 2AFZUSAP102

Page Number : 1 of 38

Report Issued Date : Jul. 20, 2016

Report Version : Rev. 03

Report Template No.: BU5-FR15EWLAC MA Version 1.4



TABLE OF CONTENTS

REVISION HISTORY 3

SUMMARY OF TEST RESULT 4

1 GENERAL DESCRIPTION 5

 1.1 Applicant 5

 1.2 Manufacturer 5

 1.3 Product Feature of Equipment Under Test 5

 1.4 Product Specification of Equipment Under Test 6

 1.5 Modification of EUT 6

 1.6 Testing Location 7

 1.7 Applicable Standards 8

2 TEST CONFIGURATION OF EQUIPMENT UNDER TEST 9

 2.1 Carrier Frequency and Channel 9

 2.2 Test Mode 10

 2.3 Connection Diagram of Test System 11

 2.4 Support Unit used in test configuration and system 12

 2.5 EUT Operation Test Setup 13

 2.6 Measurement Results Explanation Example 13

3 TEST RESULT 14

 3.1 26dB & 99% Occupied Bandwidth Measurement 14

 3.2 Maximum Conducted Output Power Measurement 18

 3.3 Power Spectral Density Measurement 21

 3.4 Unwanted Emissions Measurement 25

 3.5 AC Conducted Emission Measurement 29

 3.6 Frequency Stability Measurement 33

 3.7 Automatically Discontinue Transmission 34

 3.8 Antenna Requirements 35

4 LIST OF MEASURING EQUIPMENT 37

5 UNCERTAINTY OF EVALUATION 38

APPENDIX A. CONDUCTED TEST RESULTS

APPENDIX B. RADIATED SPURIOUS EMISSION

APPENDIX C. RADIATED SPURIOUS EMISSION PLOTS

APPENDIX D. DUTY CYCLE PLOTS

APPENDIX E. SETUP PHOTOGRAPHS



REVISION HISTORY

REPORT NO.	VERSION	DESCRIPTION	ISSUED DATE
FR652049D	Rev. 01	Initial issue of report	Jul. 14, 2016
FR652049D	Rev. 02	Added note that 99% Bandwidth were measured and shown to be within 5250 MHz in appendix A.	Jul. 19, 2016
FR652049D	Rev. 03	Added note that 99% Bandwidth were measured and shown to be within 5250 MHz in appendix A for VHT40 and VHT80	Jul. 20, 2016



SUMMARY OF TEST RESULT

Report Section	FCC Rule	Description	Limit	Result	Remark
3.1	2.1049 15.403(i)	26dB & 99% Bandwidth	-	Pass	-
3.2	15.407(a)	Maximum Conducted Output Power	≤ 24 dBm (depend on band)	Pass	-
3.3	15.407(a)	Power Spectral Density	≤ 11 dBm (depend on band)	Pass	-
3.4	15.407(b)	Unwanted Emissions	≤ -17, -27 dBm (depend on band)&15.209(a)	Pass	Under limit 0.23 dB at 5149.760 MHz
3.5	15.207	AC Conducted Emission	15.207(a)	Pass	Under limit 3.90 dB at 0.550 MHz
3.6	15.407(g)	Frequency Stability	Within Operation Band	Pass	-
3.7	15.407(c)	Automatically Discontinue Transmission	Discontinue Transmission	Pass	-
3.8	15.203 & 15.407(a)	Antenna Requirement	N/A	Pass	-



1 General Description

1.1 Applicant

Ignition Design Labs (US) LLC

5F-2., No. 158, Sec. 2, Gongdao 5th Rd., Hsinchu City 30070, Taiwan

1.2 Manufacturer

Ignition Design Labs (US) LLC

5F-2., No. 158, Sec. 2, Gongdao 5th Rd., Hsinchu City 30070, Taiwan

1.3 Product Feature of Equipment Under Test

Product Feature	
Equipment	Advanced Wireless Router
Brand Name	Ignition Design Labs
Model Name	Portal
Marketing Name	Portal
FCC ID	2AFZUSAP102
EUT supports Radios application	WLAN 11a/b/g/n HT20/HT40 WLAN 11ac VHT20/VHT40/VHT80 Bluetooth v4.1 EDR/LE
HW Version	v1.0
SW Version	v1.0
EUT Stage	Identical Prototype

Remark: The above EUT's information was declared by manufacturer. Please refer to the specifications or user's manual for more detailed description.



1.4 Product Specification of Equipment Under Test

Standards-related Product Specification											
Tx/Rx Channel Frequency Range	5180 MHz ~ 5240 MHz										
Maximum Output Power <CDD Modes>	<5180 MHz ~ 5240 MHz> MIMO <Ant. Port 1+2+3+4> 802.11a : 25.30 dBm / 0.3388 W 802.11n HT20 : 21.40 dBm / 0.1380 W 802.11n HT40 : 24.02 dBm / 0.2523 W										
Maximum Output Power <TXBF Modes>	<5180 MHz ~ 5240 MHz> MIMO <Ant. Port 1+2+3+4> 802.11ac VHT20: 19.45 dBm / 0.0881 W 802.11ac VHT40: 21.99 dBm / 0.1581 W 802.11ac VHT80: 20.65 dBm / 0.1161 W										
99% Occupied Bandwidth <CDD Modes>	802.11a : 17.20 MHz										
99% Occupied Bandwidth <TXBF Modes>	802.11ac VHT20 : 18.90 MHz 802.11ac VHT40 : 37.00 MHz 802.11ac VHT80 : 76.20 MHz										
Type of Modulation	802.11a/n : OFDM (BPSK / QPSK / 16QAM / 64QAM) 802.11ac : OFDM (BPSK / QPSK / 16QAM / 64QAM / 256QAM)										
Antenna Type	PCB Antenna										
Antenna Gain	Antenna 1: 2.55 dBi Antenna 2: 3.38 dBi Antenna 3: 3.82 dBi Antenna 4: 3.00 dBi										
Antenna Function Description	<table border="1"> <thead> <tr> <th></th> <th>Ant. 1</th> <th>Ant. 2</th> <th>Ant. 3</th> <th>Ant. 4</th> </tr> </thead> <tbody> <tr> <td>802.11 a/n/ac MIMO</td> <td>V</td> <td>V</td> <td>V</td> <td>V</td> </tr> </tbody> </table>		Ant. 1	Ant. 2	Ant. 3	Ant. 4	802.11 a/n/ac MIMO	V	V	V	V
	Ant. 1	Ant. 2	Ant. 3	Ant. 4							
802.11 a/n/ac MIMO	V	V	V	V							

1.5 Modification of EUT

No modifications are made to the EUT during all test items.



1.6 Testing Location

Sporton Lab is accredited to ISO 17025 by Taiwan Accreditation Foundation (TAF code : 1190) and the FCC designation No. TW1022 under the FCC 2.948(e) by Mutual Recognition Agreement (MRA) in FCC Test.

Test Site	SPORTON INTERNATIONAL INC.	
Test Site Location	No. 52, Hwa Ya 1 st Rd., Hwa Ya Technology Park, Kwei-Shan District, Tao Yuan City, Taiwan, R.O.C. TEL: +886-3-327-3456 FAX: +886-3-328-4978	
Test Site No.	Sporton Site No.	
	TH02-HY	CO05-HY

Note: The test site complies with ANSI C63.4 2014 requirement.

Test Site	SPORTON INTERNATIONAL INC.	
Test Site Location	No.58, Aly. 75, Ln. 564, Wenhua 3rd Rd. Guishan Dist, Taoyuan City, Taiwan (R.O.C.) TEL: +886-3-327-0868 FAX: +886-3-327-0855	
Test Site No.	Sporton Site No.	
	03CH10-HY	

Note: The test site complies with ANSI C63.4 2014 requirement.



1.7 Applicable Standards

According to the specifications of the manufacturer, the EUT must comply with the requirements of the following standards:

- ♦ FCC Part 15 Subpart E
- ♦ FCC KDB 789033 D02 General UNII Test Procedures New Rules v01r02
- ♦ FCC KDB 662911 D01 Multiple Transmitter Output v02r01.
- ♦ FCC KDB 644545 D03 Guidance for IEEE 802 11ac New Rules v01
- ♦ ANSI C63.10-2013

Remark:

1. All test items were verified and recorded according to the standards and without any deviation during the test.
2. This EUT has also been tested and complied with the requirements of FCC Part 15, Subpart B, recorded in a separate test report.



2 Test Configuration of Equipment Under Test

The EUT has been associated with peripherals and configuration operated in a manner tended to maximize its emission characteristics in a typical application. Frequency range investigated: conducted emission (150 kHz to 30 MHz) and radiated emission (9 kHz to the 10th harmonic of the highest fundamental frequency or to 40 GHz, whichever is lower). For radiated measurement, pre-scanned in three orthogonal panels, X, Y, Z. The worst cases (X plane) were recorded in this report.

Based on the worst configuration found above, the RF power setting is set individually to meet FCC compliance limit for the final conducted and radiated tests shown in section 2.2.

2.1 Carrier Frequency and Channel

Frequency Band	Channel	Freq. (MHz)	Channel	Freq. (MHz)
5150-5250 MHz Band 1 (U-NII-1)	36	5180	44	5220
	38	5190	46	5230
	40	5200	48	5240
	42	5210		

Note: The above Frequency and Channel in boldface were 802.11n HT40.



2.2 Test Mode

Final test mode of conducted test items and radiated spurious emissions are considering the modulation and worse data rates as below table.

Modulation	Data Rate
802.11a	6 Mbps
802.11n HT20	MCS0
802.11n HT40	MCS0
802.11ac VHT20	MCS0
802.11ac VHT40	MCS0
802.11ac VHT80	MCS0

	MIMO mode	Power	Conducted	RSE
802.11a	CDD	Test	Test	Test
802.11n HT20/HT40	CDD	Test	Covered by 802.11ac	Covered by 802.11ac
802.11ac VHT20/VHT40/VHT80	TXBF	Test	Test	Test

Test Cases	
AC Conducted Emission	Mode 1 : Bluetooth Link + WLAN (5GHz) Link 802.11ac VHT80 MCS0 + LAN Link + USB Link + Adapter 1

Ch. #	Band I : 5150-5250 MHz		
	802.11a	802.11n HT20	802.11n HT40
L Low	36	36	38
M Middle	44	44	-
H High	48	48	46

Ch. #	Band I : 5150-5250 MHz		
	802.11ac VHT20	802.11ac VHT40	802.11ac VHT80
L Low	36	38	-
M Middle	44	-	42
H High	48	46	-

2.3 Connection Diagram of Test System

<WLAN Tx CDD Mode>

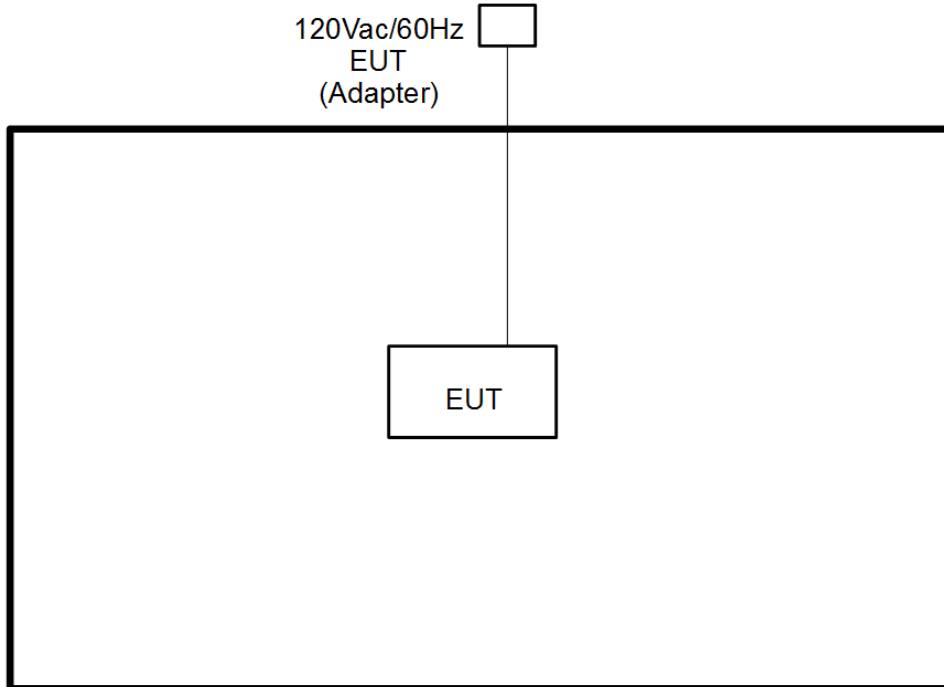

<WLAN Tx TXBF Mode>

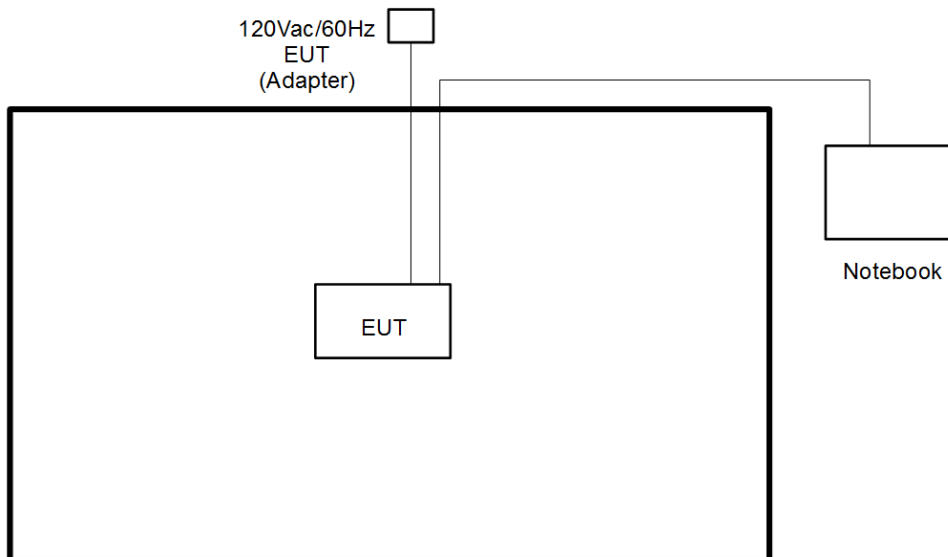

<AC Conducted Emission Mode>

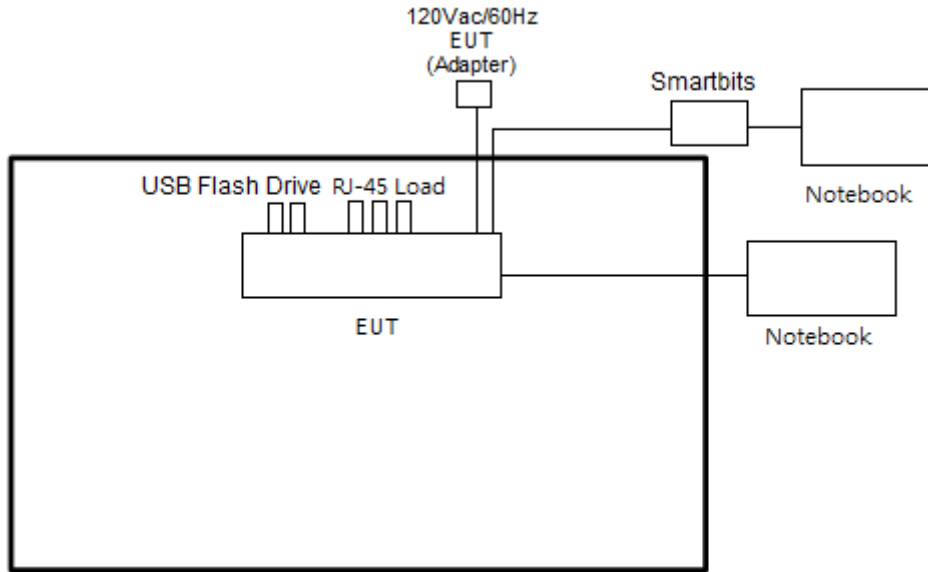

2.4 Support Unit used in test configuration and system

Item	Equipment	Trade Name	Model Name	FCC ID	Data Cable	Power Cord
1.	Notebook	DELL	Latitude E6320	FCC DoC/ Contains FCC ID: QDS-BRCM1054	N/A	AC I/P: Unshielded, 1.2 m DC O/P: Shielded, 1.8 m
2.	Notebook	DELL	P20G	FCC DoC/ Contains FCC ID: QDS-BRCM1051	N/A	AC I/P: Unshielded, 1.2 m DC O/P: Shielded, 1.8 m
3.	USB flash drive	Transcend	JetFlash 700	FCC DoC	N/A	N/A
4.	Smartbits	Spirent	SMB600B	N/A	Shielded, 1.5 m	Unshielded, 1.8 m



2.5 EUT Operation Test Setup

For CDD modes, programmed RF utility, "QRCT" installed in the notebook make the EUT provide functions like channel selection and power level for continuous transmitting and receiving signals.

For TXBF modes, Software "LANTEST.EXE" v2.0.0.2 installed in the notebook and command lines make the EUT provide functions like channel selection and power level for continuous transmitting and receiving signals.

2.6 Measurement Results Explanation Example

For all conducted test items:

The offset level is set in the spectrum analyzer to compensate the RF cable loss and attenuator factor between EUT conducted output port and spectrum analyzer. With the offset compensation, the spectrum analyzer reading level is exactly the EUT RF output level.

Example :

The spectrum analyzer offset is derived from RF cable loss and attenuator factor.

Offset = RF cable loss + attenuator factor.

Following shows an offset computation example with cable loss 4.2 dB and 10dB attenuator.

$$\begin{aligned} \text{Offset(dB)} &= \text{RF cable loss(dB)} + \text{attenuator factor(dB)}. \\ &= 4.2 + 10 = 14.2 \text{ (dB)} \end{aligned}$$



3 Test Result

3.1 26dB & 99% Occupied Bandwidth Measurement

3.1.1 Description of 26dB & 99% Occupied Bandwidth

This section is for reporting purpose only.

There is no restriction limits for bandwidth.

3.1.2 Measuring Instruments

The measuring equipment is listed in the section 4 of this test report.

3.1.3 Test Procedures

1. The testing follows FCC KDB 789033 D02 General UNII Test Procedures New Rules v01r02.
Section C) Emission bandwidth
2. Set RBW = approximately 1% of the emission bandwidth.
3. Set the VBW > RBW.
4. Detector = Peak.
5. Trace mode = max hold
6. Measure the maximum width of the emission that is 26 dB down from the peak of the emission.
Compare this with the RBW setting of the analyzer. Readjust RBW and repeat measurement as needed until the RBW/EBW ratio is approximately 1%.
7. For 99% Bandwidth Measurement, the spectrum analyzer's resolution bandwidth (RBW) is set 1MHz and set the Video bandwidth (VBW) $\geq 3 * RBW$.
8. Measure and record the results in the test report.

3.1.4 Test Setup

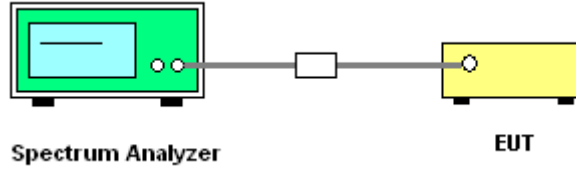

3.1.5 Test Result of 26dB & 99% Occupied Bandwidth

Please refer to Appendix A.



<CDD Modes>

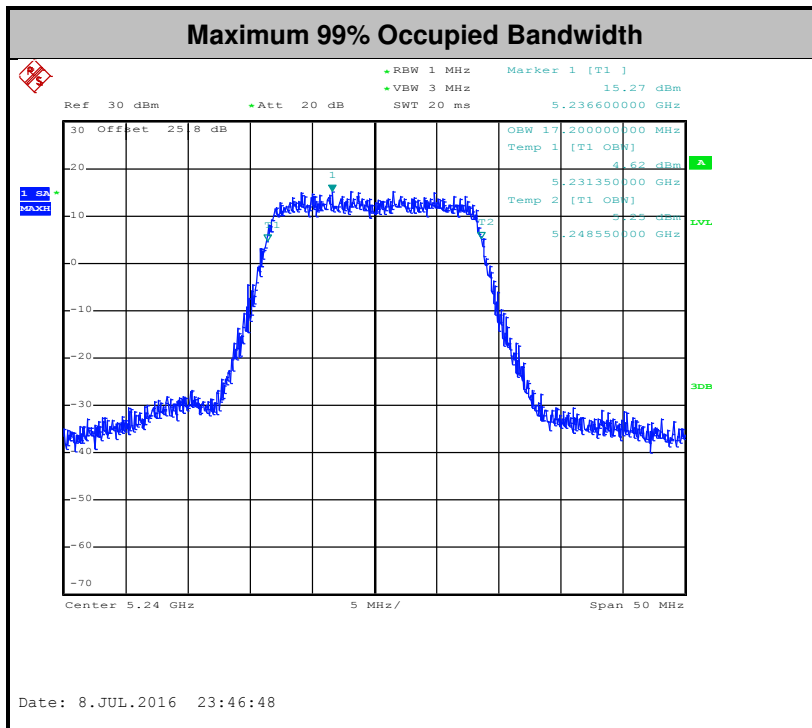
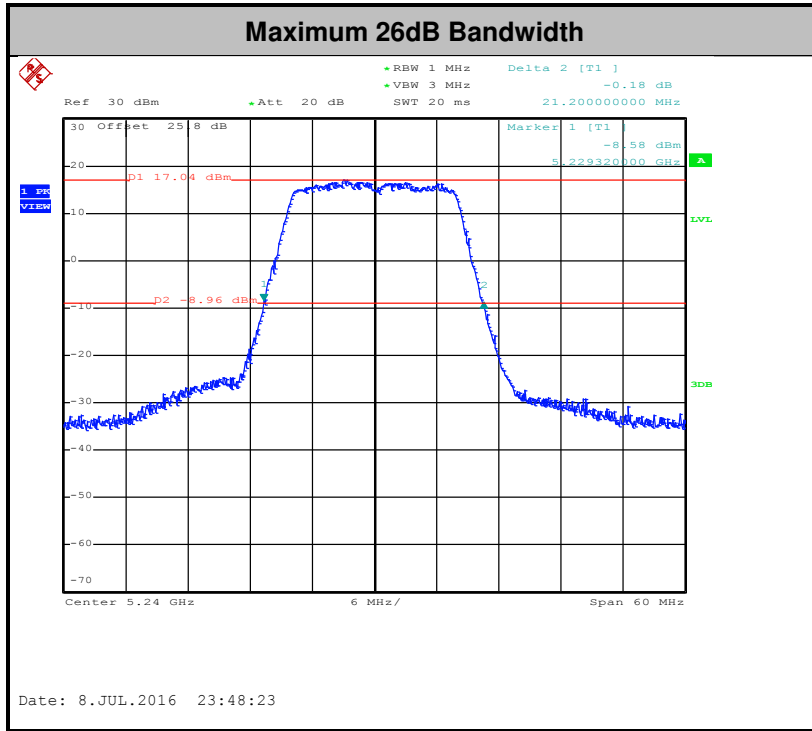

Note: The occupied channel bandwidth is maintained within the band of operation for all of the modulations.



<TXBF Modes>

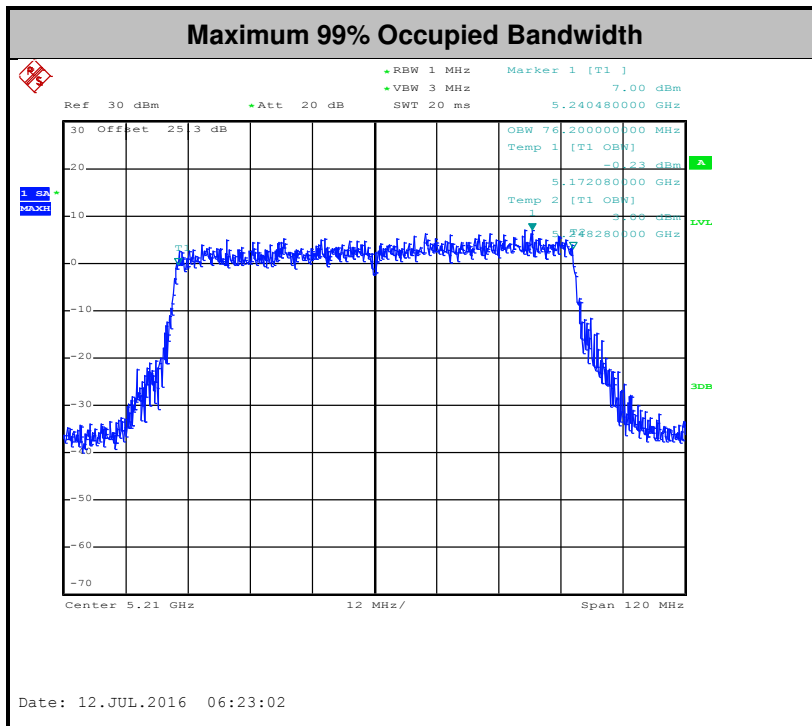
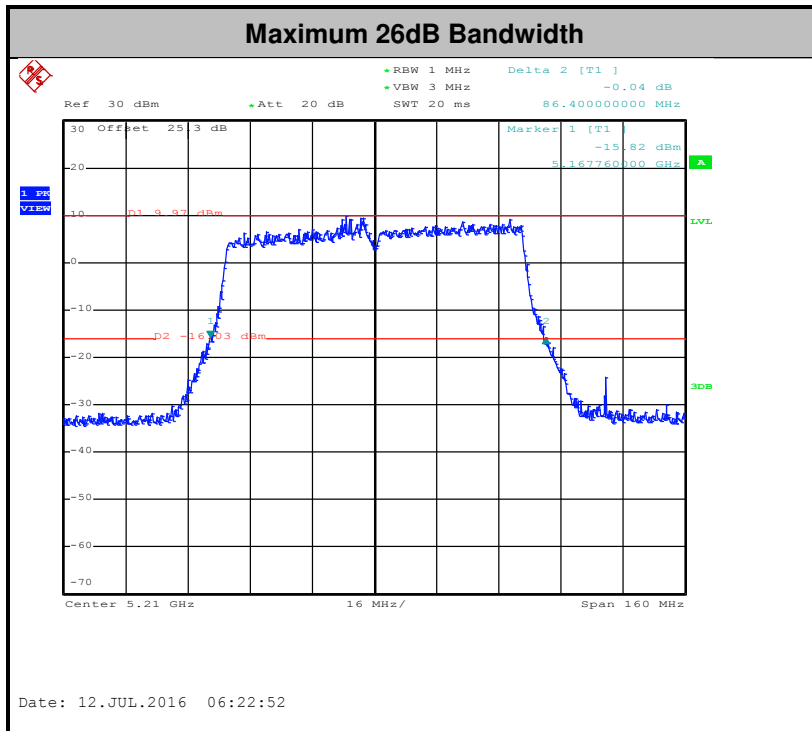

Note: The occupied channel bandwidth is maintained within the band of operation for all of the modulations.



3.2 Maximum Conducted Output Power Measurement

3.2.1 Limit of Maximum Conducted Output Power

For mobile and portable client devices in the 5.15–5.25 GHz band, the maximum conducted output power over the frequency band of operation shall not exceed 250 mW.

If transmitting antennas of directional gain greater than 6 dBi are used, the peak output power shall be reduced by the amount in dB that the directional gain of the antenna exceeds 6 dBi.

Note that U-NII-2 band, devices with a maximum e.i.r.p. greater than 500 mW shall implement TPC in order to have the capability to operate at least 6 dB below the maximum permitted e.i.r.p. of 1 W.

3.2.2 Measuring Instruments

The measuring equipment is listed in the section 4 of this test report.



3.2.3 Test Procedures

CDD modes

The testing follows Method PM of FCC KDB 789033 D02 General UNII Test Procedures New Rules v01r02 for CDD modes.

Method PM (Measurement using an RF average power meter):

1. Measurement is performed using a wideband RF power meter.
2. The EUT is configured to transmit continuously with a consistent duty cycle at its maximum power control level.
3. Measure the average power of the transmitter, and the average power is corrected with duty factor, $10 \log(1/x)$, where x is the duty cycle.

TXBF modes

The testing follows Method PM-G of FCC KDB 789033 D02 General UNII Test Procedures New Rules v01r02 for TXBF modes.

Method PM-G (Measurement using a gated RF average power meter):

1. Measurement is performed using a wideband RF power meter.
2. The EUT is configured to transmit at its maximum power control level.
3. Measure the average power of the transmitter
4. Since the measurement is made only during the ON time of the transmitter, no duty cycle correction factor is required.

3.2.4 Test Setup

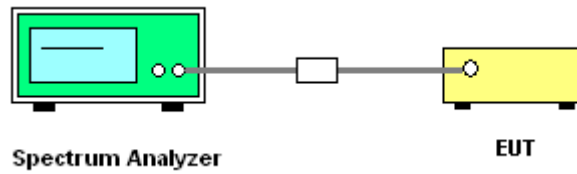

3.2.5 Test Result of Maximum Conducted Output Power

Please refer to Appendix A.



3.3 Power Spectral Density Measurement

3.3.1 Limit of Power Spectral Density

For mobile and portable client devices in the 5.15–5.25 GHz band, the maximum power spectral density shall not exceed 11dBm in any 1 megahertz band.

If transmitting antennas of directional gain greater than 6 dBi are used, the peak output power shall be reduced by the amount in dB that the directional gain of the antenna exceeds 6 dBi.

3.3.2 Measuring Instruments

The measuring equipment is listed in the section 4 of this test report.



3.3.3 Test Procedures

The testing follows FCC KDB 789033 D02 General UNII Test Procedures New Rules v01r02.
Section F) Maximum power spectral density.

CDD modes

Method SA-2

(trace averaging across on and off times of the EUT transmissions, followed by duty cycle correction).

- Measure the duty cycle.
- Set span to encompass the entire emission bandwidth (EBW) of the signal.
- Set RBW = 1 MHz.
- Set VBW \geq 3 MHz.
- Number of points in sweep \geq 2 Span / RBW.
- Sweep time = auto.
- Detector = RMS
- Trace average at least 100 traces in power averaging mode.
- Add $10 \log(1/x)$, where x is the duty cycle, to the measured power in order to compute the average power during the actual transmission times. For example, add $10 \log(1/0.25) = 6$ dB if the duty cycle is 25 percent.

TXBF modes

Method SA-3

(power averaging (rms) detection with max hold):

- Set span to encompass the entire emission bandwidth (EBW) of the signal.
- Set RBW = 1 MHz.
- Set VBW \geq 3 MHz
- Number of points in sweep \geq 2 Span / RBW.
- Sweep time \leq (number of points in sweep) \times T, when duty cycle is less than 98 percent where T is the minimum transmission duration over which the transmitter is on and is transmitting at its maximum power control level for the tested mode of operation.
- Detector = power averaging (rms).
- Trace mode = max hold.
- Allow max hold to run for at least 60 seconds, or longer as needed to allow the trace to stabilize.

1. The RF output of EUT was connected to the spectrum analyzer by a low loss cable.
2. Each plot has already offset with cable loss, and attenuator loss. Measure the PPSD and record it.
3. For MIMO mode, calculation method follows FCC KDB 662911 D01 Multiple Transmitter Output v02r01.

Method (a): Measure and sum the spectra across the outputs.

The total final Power Spectral Density is from a device with all transmitter outputs. The spectrum measurements of the individual outputs are all performed with the same span and number of points, the spectrum value in the first spectral bin of output 1 is summed with that in the first spectral bin of output 2, output 3 and output 4 to obtain the value for the first frequency bin of the summed spectrum.

3.3.4 Test Setup

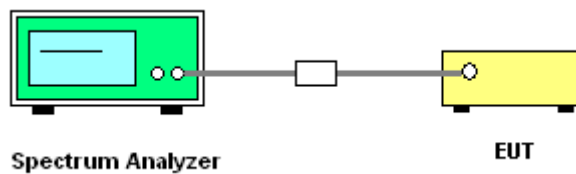

3.3.5 Test Result of Power Spectral Density

Please refer to Appendix A.



<CDD Modes>

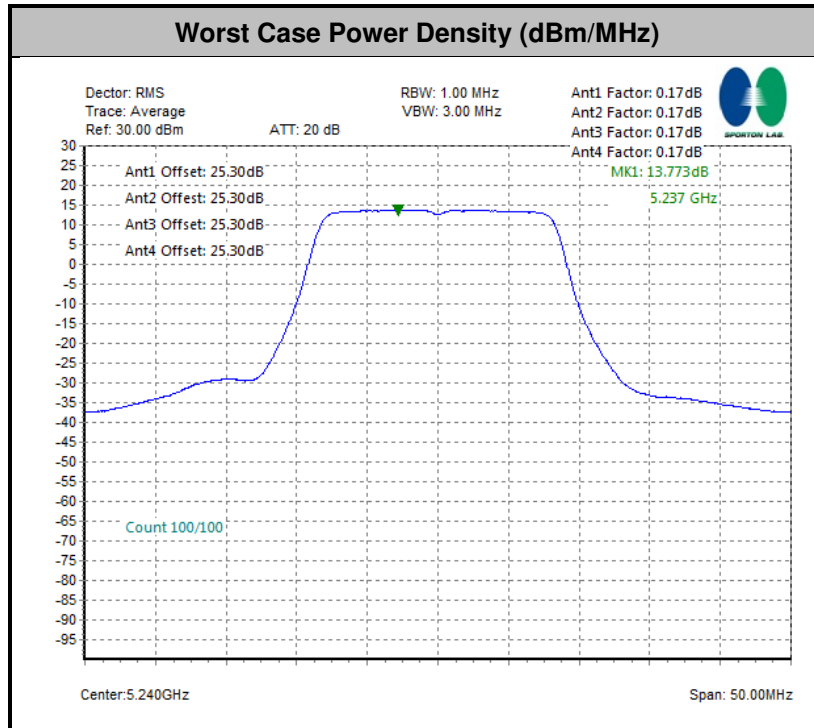

Note: Average Power Density (dB) = Measured value+ Duty Factor

<TXBF Modes>

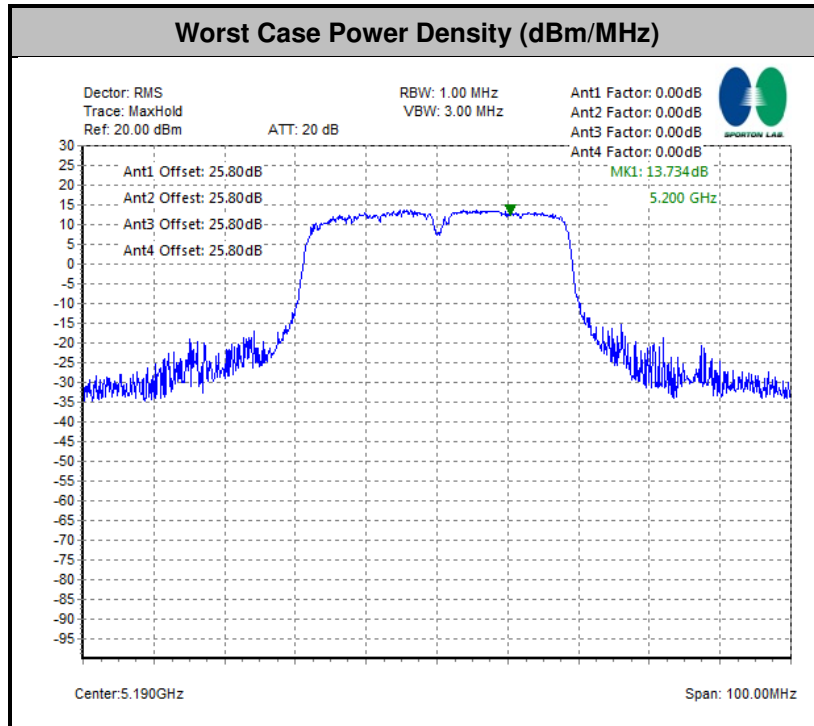

Note: Average Power Density (dB) = Measured value



3.4 Unwanted Emissions Measurement

This section as specified in FCC Part 15.407(b) is to measure unwanted emissions through radiated measurement for band edge spurious emissions and out of band emissions measurement. The unwanted emissions shall comply with 15.407(b)(1) to (6), and restricted bands per FCC Part15.205.

3.4.1 Limit of Unwanted Emissions

- (1) For transmitters operating in the 5150-5250 MHz band: all emissions outside of the 5150-5350 MHz band shall not exceed an EIRP of -27dBm/MHz.
- (2) Unwanted spurious emissions fallen in restricted bands per FCC Part15.205 shall comply with the general field strength limits set forth in § 15.209 as below table,

Frequency (MHz)	Field Strength (microvolts/meter)	Measurement Distance (meters)
0.009 – 0.490	2400/F(kHz)	300
0.490 – 1.705	24000/F(kHz)	30
1.705 – 30.0	30	30
30 – 88	100	3
88 – 216	150	3
216 - 960	200	3
Above 960	500	3

Note: The following formula is used to convert the EIRP to field strength.

$$E = \frac{1000000\sqrt{30P}}{3} \mu V/m, \text{ where } P \text{ is the eirp (Watts)}$$

EIRP (dBm)	Field Strength at 3m (dBμV/m)
-17	78.3
- 27	68.3

- (3) KDB789033 D02 v01r02 G)2)c) As specified in 15.407(b), emissions above 1000 MHz that are outside of the restricted bands are subject to a peak emission limit of -27 dBm/MHz (or -17 dBm/MHz as specified in 15.407(b)(4)). However, an out-of-band emission that complies with both the average and peak limits of 15.209 is not required to satisfy the -27 dBm/MHz or -17 dBm/MHz peak emission limit.



3.4.2 Measuring Instruments

The measuring equipment is listed in the section 4 of this test report.

3.4.3 Test Procedures

1. The testing follows FCC KDB 789033 D02 General UNII Test Procedures New Rules v01r02. Section G) Unwanted emissions measurement.
 - (1) Procedure for Unwanted Emissions Measurements Below 1000MHz
 - RBW = 120 kHz
 - VBW = 300 kHz
 - Detector = Peak
 - Trace mode = max hold
 - (2) Procedure for Peak Unwanted Emissions Measurements Above 1000 MHz
 - RBW = 1 MHz
 - VBW \geq 3 MHz
 - Detector = Peak
 - Sweep time = auto
 - Trace mode = max hold
 - (3) Procedures for Average Unwanted Emissions Measurements Above 1000MHz
 - RBW = 1 MHz
 - VBW = 10 Hz, when duty cycle is no less than 98 percent.
 - VBW \geq 1/T, when duty cycle is less than 98 percent where T is the minimum transmission duration over which the transmitter is on and is transmitting at its maximum power control level for the tested mode of operation.
2. The EUT was placed on a turntable with 0.8 meter for frequency below 1GHz and 1.5 meter for frequency above 1GHz respectively above ground.
3. The EUT was set 3 meters from the interference receiving antenna which was mounted on the top of a variable height antenna tower.
4. The antenna is a broadband antenna and its height is adjusted between one meter and four meters above ground to find the maximum value of the field strength for both horizontal polarization and vertical polarization of the antenna.
5. For each suspected emission, the EUT was arranged to its worst case and then adjust the antenna tower (from 1 m to 4 m) and turntable (from 0 degree to 360 degrees) to find the maximum reading.
6. For testing below 1GHz, if the emission level of the EUT in peak mode was 3 dB lower than the limit specified, then peak values of EUT will be reported, otherwise, the emissions will be repeated one by one using the CISPR quasi-peak method and reported.

- For testing above 1GHz, the emission level of the EUT in peak mode was 20dB lower than average limit (that means the emission level in average mode also complies with the limit in average mode), then peak values of EUT will be reported, otherwise, the emissions will be measured in average mode again and reported.

3.4.4 Test Setup

For radiated emissions below 30MHz

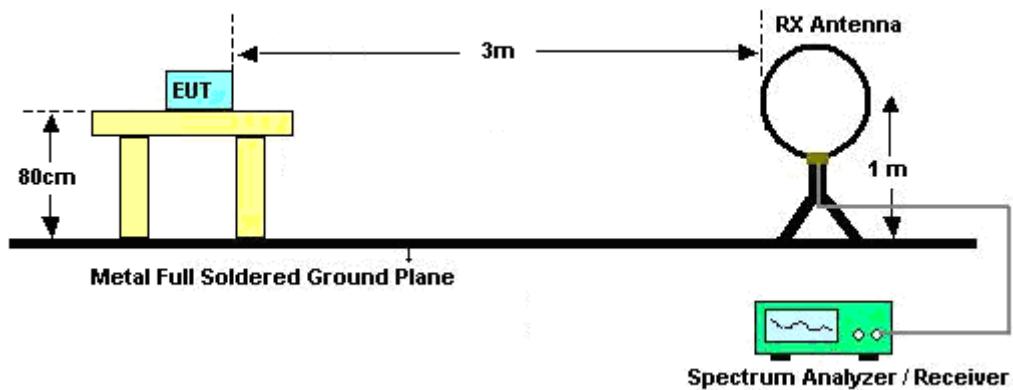

For radiated emissions from 30MHz to 1GHz

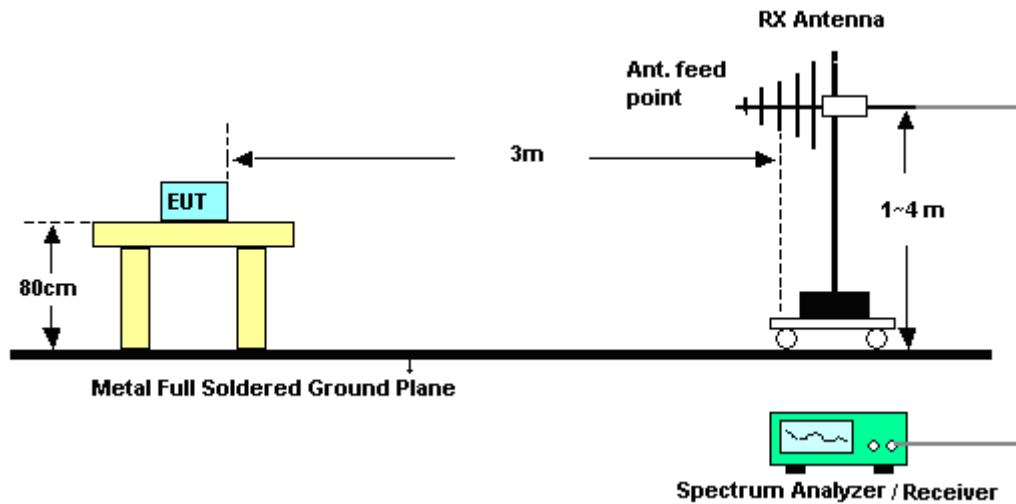

For radiated emissions above 1GHz

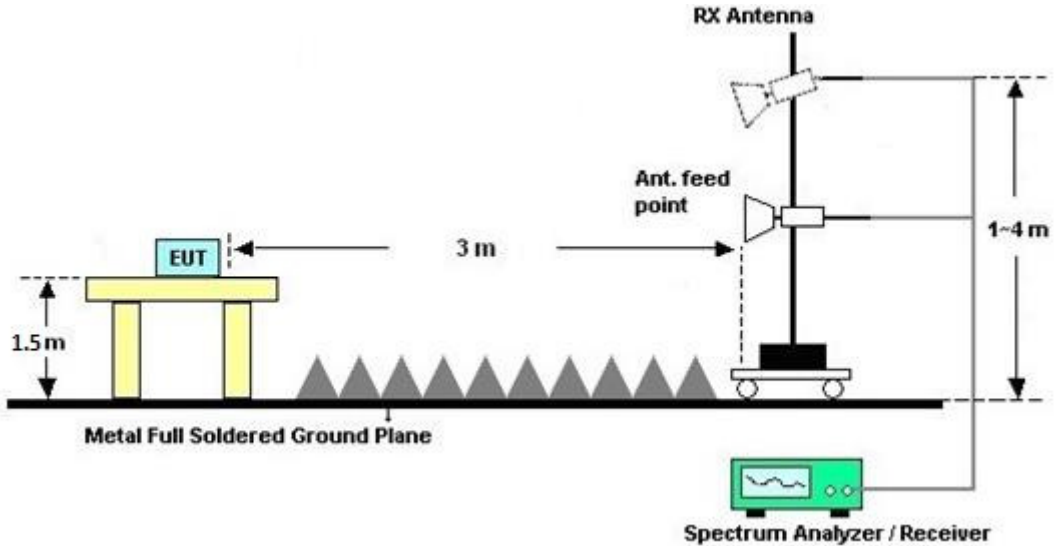

3.4.5 Test Results of Radiated Emissions (9 kHz ~ 30 MHz)

The low frequency, which started from 9 kHz to 30MHz, was pre-scanned and the result which was 20dB lower than the limit line per 15.31(o) was not reported.

3.4.6 Test Result of Radiated Band Edges

Please refer to Appendix B and C.

3.4.7 Duty Cycle

Please refer to Appendix D.

3.4.8 Test Result of Unwanted Radiated Emission (30MHz ~ 10th Harmonic)

Please refer to Appendix B and C.



3.5 AC Conducted Emission Measurement

3.5.1 Limit of AC Conducted Emission

For equipment that is designed to be connected to the public utility (AC) power line, the radio frequency voltage that is conducted back onto the AC power line on any frequency or frequencies within the band 150 kHz to 30 MHz shall not exceed the limits in the following table.

Frequency of emission (MHz)	Conducted limit (dBµV)	
	Quasi-peak	Average
0.15-0.5	66 to 56*	56 to 46*
0.5-5	56	46
5-30	60	50

*Decreases with the logarithm of the frequency.

3.5.2 Measuring Instruments

The measuring equipment is listed in the section 4 of this test report.

3.5.3 Test Procedures

1. The EUT was placed 0.4 meter from the conducting wall of the shielding room was kept at least 80 centimeters from any other grounded conducting surface.
2. Connect EUT to the power mains through a line impedance stabilization network (LISN).
3. All the support units are connecting to the other LISN.
4. The LISN provides 50 ohm coupling impedance for the measuring instrument.
5. The FCC states that a 50 ohm, 50 microhenry LISN should be used.
6. Both sides of AC line were checked for maximum conducted interference.
7. The frequency range from 150 kHz to 30 MHz was searched.
8. Set the test-receiver system to Peak Detect Function and specified bandwidth with Maximum Hold Mode.

3.5.4 Test Setup

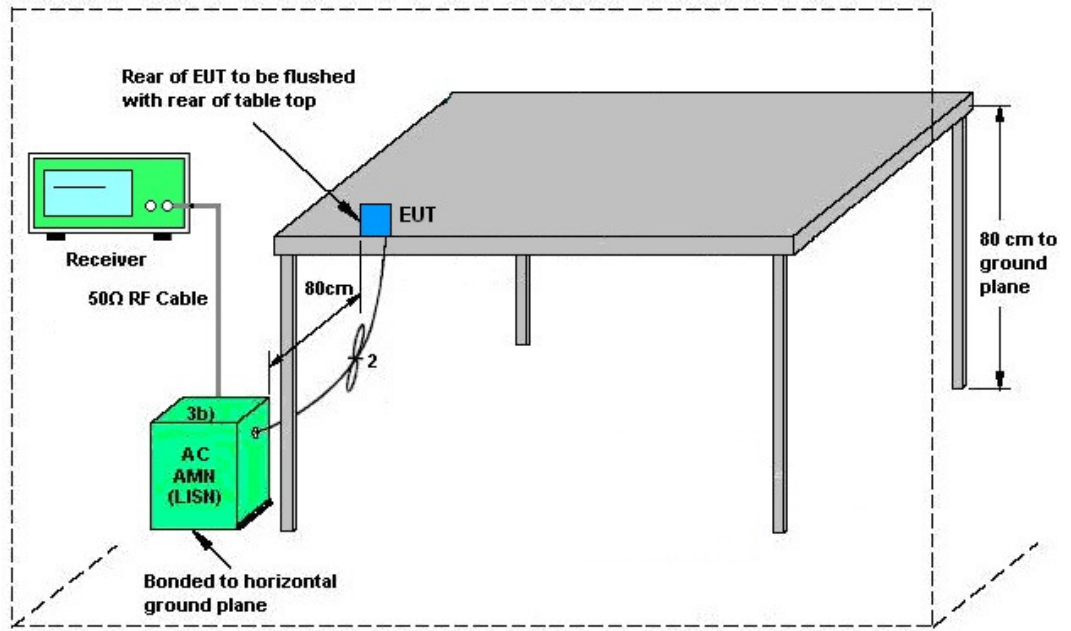

AMN = Artificial mains network (LISN)
AE = Associated equipment
EUT = Equipment under test
ISN = Impedance stabilization network



3.5.5 Test Result of AC Conducted Emission

Test Mode :	Mode 1	Temperature :	22~23°C
Test Engineer :	Arthur Hsieh	Relative Humidity :	50~51%
Test Voltage :	120Vac / 60Hz	Phase :	Line
Function Type :	Bluetooth Link + WLAN (5GHz) Link 802.11ac VHT80 MCS0 + LAN Link + USB Link + Adapter 1		

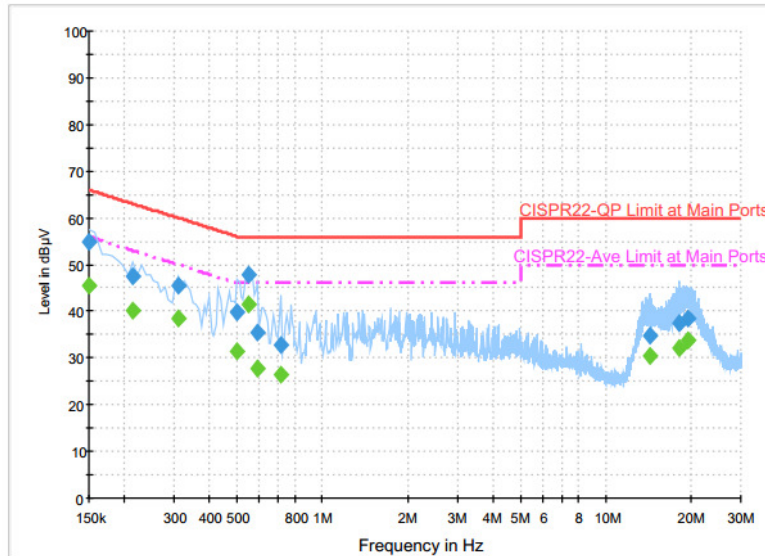

Final Result : QuasiPeak

Frequency (MHz)	QuasiPeak (dBµV)	Filter	Line	Corr. (dB)	Margin (dB)	Limit (dBµV)
0.150000	54.7	Off	L1	19.6	11.3	66.0
0.214000	47.5	Off	L1	19.6	15.5	63.0
0.310000	45.6	Off	L1	19.6	14.4	60.0
0.502000	39.7	Off	L1	19.6	16.3	56.0
0.550000	47.7	Off	L1	19.6	8.3	56.0
0.590000	35.6	Off	L1	19.6	20.4	56.0
0.710000	32.7	Off	L1	19.6	23.3	56.0
14.286000	34.9	Off	L1	20.4	25.1	60.0
18.094000	37.4	Off	L1	20.6	22.6	60.0
19.574000	38.3	Off	L1	20.7	21.7	60.0

Final Result : Average

Frequency (MHz)	Average (dBµV)	Filter	Line	Corr. (dB)	Margin (dB)	Limit (dBµV)
0.150000	45.6	Off	L1	19.6	10.4	56.0
0.214000	40.3	Off	L1	19.6	12.7	53.0
0.310000	38.6	Off	L1	19.6	11.4	50.0
0.502000	31.4	Off	L1	19.6	14.6	46.0
0.550000	41.5	Off	L1	19.6	4.5	46.0
0.590000	27.8	Off	L1	19.6	18.2	46.0
0.710000	26.4	Off	L1	19.6	19.6	46.0
14.286000	30.3	Off	L1	20.4	19.7	50.0
18.094000	32.1	Off	L1	20.6	17.9	50.0
19.574000	33.8	Off	L1	20.7	16.2	50.0



Test Mode :	Mode 1	Temperature :	22~23°C
Test Engineer :	Arthur Hsieh	Relative Humidity :	50~51%
Test Voltage :	120Vac / 60Hz	Phase :	Neutral
Function Type :	Bluetooth Link + WLAN (5GHz) Link 802.11ac VHT80 MCS0 + LAN Link + USB Link + Adapter 1		

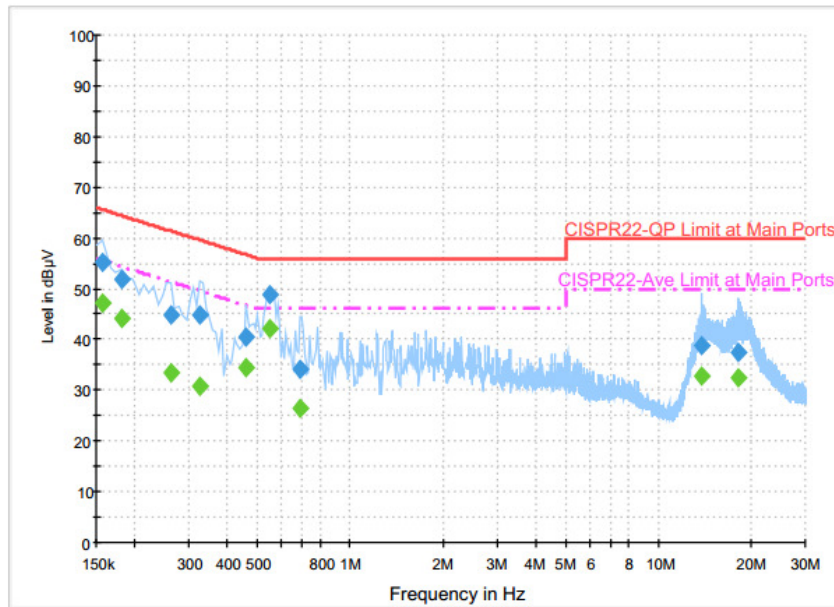

Final Result : QuasiPeak

Frequency (MHz)	QuasiPeak (dBµV)	Filter	Line	Corr. (dB)	Margin (dB)	Limit (dBµV)
0.158000	55.2	Off	N	19.6	10.4	65.6
0.182000	51.7	Off	N	19.6	12.7	64.4
0.262000	44.7	Off	N	19.6	16.7	61.4
0.326000	45.0	Off	N	19.6	14.6	59.6
0.462000	40.5	Off	N	19.6	16.2	56.7
0.550000	48.7	Off	N	19.6	7.3	56.0
0.686000	34.0	Off	N	19.6	22.0	56.0
13.870000	38.7	Off	N	20.4	21.3	60.0
18.254000	37.3	Off	N	20.6	22.7	60.0

Final Result : Average

Frequency (MHz)	Average (dBµV)	Filter	Line	Corr. (dB)	Margin (dB)	Limit (dBµV)
0.158000	47.0	Off	N	19.6	8.6	55.6
0.182000	44.0	Off	N	19.6	10.4	54.4
0.262000	33.4	Off	N	19.6	18.0	51.4
0.326000	30.9	Off	N	19.6	18.7	49.6
0.462000	34.4	Off	N	19.6	12.3	46.7
0.550000	42.1	Off	N	19.6	3.9	46.0
0.686000	26.4	Off	N	19.6	19.6	46.0
13.870000	32.9	Off	N	20.4	17.1	50.0
18.254000	32.3	Off	N	20.6	17.7	50.0

3.6 Frequency Stability Measurement

3.6.1 Limit of Frequency Stability

Manufacturers of U-NII devices are responsible for ensuring frequency stability such that an emission is maintained within the band of operation under all conditions of normal operation as specified in the user's manual.

3.6.2 Measuring Instruments

The measuring equipment is listed in the section 4 of this test report.

3.6.3 Test Procedures

1. To ensure emission at the band edge is maintained within the authorized band, those values shall be measured by radiation emissions at upper and lower frequency points, and finally compensated by frequency deviation as procedures below.
2. The EUT was operated at the maximum output power, and connected to the spectrum analyzer, which is set to maximum hold function and peak detector. The peak value of the power envelope was measured and noted. The upper and lower frequency points were respectively measured relatively 10dB lower than the measured peak value.
3. The frequency deviation was calculated by adding the upper frequency point and the lower frequency point divided by two. Those detailed values of frequency deviation are provided in table below.

3.6.4 Test Setup

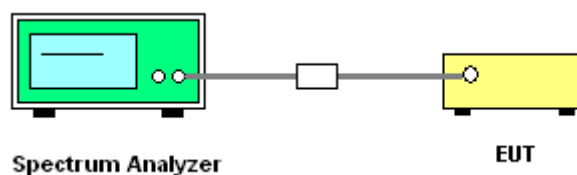

3.6.5 Test Result of Frequency Stability

Please refer to Appendix A.



3.7 Automatically Discontinue Transmission

3.7.1 Limit of Automatically Discontinue Transmission

The device shall automatically discontinue transmission in case of either absence of information to transmit or operational failure. These provisions are not intended to preclude the transmission of control or signaling information or the use of repetitive codes used by certain digital technologies to complete frame or burst intervals. Applicants shall include in their application for equipment authorization to describe how this requirement is met.

3.7.2 Measuring Instruments

The measuring equipment is listed in the section 4 of this test report.

3.7.3 Test Result of Automatically Discontinue Transmission

While the EUT is not transmitting any information, the EUT can automatically discontinue transmission and become standby mode for power saving. The EUT can detect the controlling signal of ACK message transmitting from remote device and verify whether it shall resend or discontinue transmission.



3.8 Antenna Requirements

3.8.1 Standard Applicable

According to FCC 47 CFR Section 15.407(a)(1)(2) ,if transmitting antenna directional gain is greater than 6 dBi, both the peak transmit power and the peak power spectral density shall be reduced by the amount in dB that the directional gain of the antenna exceeds 6 dBi.

3.8.2 Antenna Anti-Replacement Construction

An embedded-in antenna design is used.

3.8.3 Antenna Gain

CDD modes

FCC KDB 662911 D01 Multiple Transmitter Output v02r01

For CDD transmissions, directional gain is calculated as

Directional gain = G_{ANT} + Array Gain, where Array Gain is as follows.

For power spectral density (PSD) measurements on all devices,

Array Gain = $10 \log(N_{ANT}/N_{SS}=1)$ dB.

For power measurements on IEEE 802.11 devices,

Array Gain = 0 dB (i.e., no array gain) for $N_{ANT} \leq 4$.

Directional gain may be calculated by using the formulas applicable to equal gain antennas with G_{ANT} set equal to the gain of the antenna having the highest gain;

The EUT supports CDD mode.

For power, the directional gain G_{ANT} is set equal to the antenna having the highest gain, i.e., F)2)f)i).

For PSD, the directional gain calculation is following F)2)f)ii) of KDB 662911 D01 v02r01.

The power and PSD limit should be modified if the directional gain of EUT is over 6 dBi,

The directional gain “DG” is calculated as following table.

					DG	DG	Power	PSD
					for	for	Limit	Limit
	Ant 1	Ant 2	Ant 3	Ant 4	Power	PSD	Reduction	Reduction
	(dBi)	(dBi)	(dBi)	(dBi)	(dBi)	(dBi)	(dB)	(dB)
Band I	2.55	3.38	3.82	3.00	3.82	9.22	0.00	3.22

Power limit reduction = Composite gain – 6dBi, (min = 0)

PSD limit reduction = Composite gain + PSD Array gain – 6dBi, (min = 0)

TXBF modes

FCC KDB 662911 D01 Multiple Transmitter Output v02r01

For beamforming transmissions, directional gain is calculated as

$$DirectionalGain = 10 \cdot \log \left[\frac{\sum_{j=1}^{N_{SS}} \left\{ \sum_{k=1}^{N_{ANT}} g_{j,k} \right\}^2}{N_{ANT}} \right]$$

where

Each antenna is driven by no more than one spatial stream;

N_{SS} = the number of independent spatial streams of data;

N_{ANT} = the total number of antennas

$g_{j,k} = 10^{G_k / 20}$ if the k th antenna is being fed by spatial stream j , or zero if it is not;
 G_k is the gain in dBi of the k th antenna.

The EUT supports beamforming for 802.11ac modes.

The directional gain calculation is following F)2)e)ii) of KDB 662911 D01 v02r01.

The power and PSD limit should be modified if the directional gain of EUT is over 6 dBi,

The directional gain "DG" is calculated as following table.

					DG	DG	Power	PSD
					for	for	Limit	Limit
	Ant 1	Ant 2	Ant 3	Ant 4	Power	PSD	Reduction	Reduction
	(dBi)	(dBi)	(dBi)	(dBi)	(dBi)	(dBi)	(dB)	(dB)
Band IV	2.55	3.38	3.82	3.00	9.22	9.22	3.22	3.22

$Power\ Limit\ Reduction = DG(Power) - 6dBi, (min = 0)$

$PSD\ Limit\ Reduction = DG(PSD) - 6dBi, (min = 0)$



4 List of Measuring Equipment

Instrument	Manufacturer	Model No.	Serial No.	Characteristics	Calibration Date	Test Date	Due Date	Remark
AC Power Source	AC POWER	AFC-500W	F104070011	50Hz~60Hz	Dec. 02, 2015	Jun. 02, 2016 ~ Jul. 14, 2016	Dec. 01, 2016	Conducted (TH02-HY)
Power Meter	Anritsu	ML2495A	1036004	300MHz~40GHz	Jul. 29, 2015	Jun. 02, 2016 ~ Jul. 14, 2016	Jul. 28, 2016	Conducted (TH02-HY)
Power Sensor	Anritsu	MA2411B	1027253	300MHz~40GHz	Jul. 29, 2015	Jun. 02, 2016 ~ Jul. 14, 2016	Jul. 28, 2016	Conducted (TH02-HY)
Spectrum Analyzer	Rohde & Schwarz	FSP40	100055	9kHz~40GHz	Jun. 17, 2016	Jun. 02, 2016 ~ Jul. 14, 2016	Jun. 16, 2017	Conducted (TH02-HY)
Temperature Chamber	ESPEC	SU-241	92003713	-30℃ ~95℃	Jun. 15, 2015	Jun. 02, 2016 ~ Jul. 14, 2016	Jun. 14, 2016	Conducted (TH02-HY)
Temperature Chamber	ESPEC	SU-241	92003713	-30℃ ~95℃	Jun. 06, 2016	Jun. 02, 2016 ~ Jul. 14, 2016	Jun. 05, 2017	Conducted (TH02-HY)
Loop Antenna	Rohde & Schwarz	HFH2-Z2	100315	9 kHz~30 MHz	Sep. 02, 2015	Jun. 17, 2016 ~ Jul. 12, 2016	Sep. 01, 2016	Radiation (03CH10-HY)
Amplifier	SONOMA	310N	187311	9kHz~1GHz	Nov. 16, 2015	Jun. 17, 2016 ~ Jul. 12, 2016	Nov. 15, 2016	Radiation (03CH10-HY)
Bilog Antenna	TESEQ	CBL 6111D	35413	30MHz~1GHz	Jan. 13, 2016	Jun. 17, 2016 ~ Jul. 12, 2016	Jan. 12, 2017	Radiation (03CH10-HY)
Horn Antenna	SCHWARZBECK	BBHA 9120 D	9120D-1325	1GHz ~ 18GHz	Sep. 30, 2015	Jun. 17, 2016 ~ Jul. 12, 2016	Sep. 29, 2016	Radiation (03CH10-HY)
Preamplifier	Keysight	83017A	MY53270078	1GHz~26.5GHz	Nov. 13, 2015	Jun. 17, 2016 ~ Jul. 12, 2016	Nov. 12, 2016	Radiation (03CH10-HY)
Preamplifier	MITEQ	AMF-7D-0010 1800-30-10P	1902246	1GHz~18GHz	Nov. 16, 2015	Jun. 17, 2016 ~ Jul. 12, 2016	Nov. 15, 2016	Radiation (03CH10-HY)
Spectrum Analyzer	Keysight	N9010A	MY54200485	10Hz ~ 44GHz	Oct. 15, 2015	Jun. 17, 2016 ~ Jul. 12, 2016	Oct. 14, 2016	Radiation (03CH10-HY)
Antenna Mast	EMEC	AM-BS-4500-B	N/A	1~4m	N/A	Jun. 17, 2016 ~ Jul. 12, 2016	N/A	Radiation (03CH10-HY)
Turn Table	EMEC	TT 2200	N/A	0~360 Degree	N/A	Jun. 17, 2016 ~ Jul. 12, 2016	N/A	Radiation (03CH10-HY)
EMI Test Receiver	Keysight	N9038A(MXE)	MY55420170	N/A	Mar. 10, 2016	Jun. 17, 2016 ~ Jul. 12, 2016	Mar. 09, 2017	Radiation (03CH10-HY)
Preamplifier	MITEQ	JS44-1800400 0-33-8P	1840917	18GHz ~ 40GHz	Jun. 14, 2016	Jun. 17, 2016 ~ Jul. 12, 2016	Jun. 13, 2017	Radiation (03CH10-HY)
SHF-EHF Horn Antenna	SCHWARZBECK	BBHA 9170	BBHA917058 4	18GHz- 40GHz	Nov. 02, 2015	Jun. 17, 2016 ~ Jul. 12, 2016	Nov. 01, 2016	Radiation (03CH10-HY)
AC Power Source	ChainTek	APC-1000W	N/A	N/A	N/A	Jun. 24, 2016	N/A	Conduction (CO05-HY)
EMI Test Receiver	Rohde & Schwarz	ESCI 7	100724	9kHz~7GHz	Aug. 26, 2015	Jun. 24, 2016	Aug. 25, 2016	Conduction (CO05-HY)
LISN	Rohde & Schwarz	ENV216	100080	9kHz~30MHz	Dec. 02, 2015	Jun. 24, 2016	Dec. 01, 2016	Conduction (CO05-HY)
LISN	Rohde & Schwarz	ENV216	100081	9kHz~30MHz	Dec. 14, 2015	Jun. 24, 2016	Dec. 13, 2016	Conduction (CO05-HY)



5 Uncertainty of Evaluation

Uncertainty of Conducted Emission Measurement (150kHz ~ 30MHz)

Measuring Uncertainty for a Level of Confidence of 95% ($U = 2Uc(y)$)	2.26
-------------------------------------------------------------------------	------

Uncertainty of Radiated Emission Measurement (30 MHz ~ 1000 MHz)

Measuring Uncertainty for a Level of Confidence of 95% ($U = 2Uc(y)$)	5.50
-------------------------------------------------------------------------	------

Uncertainty of Radiated Emission Measurement (1GHz ~ 40GHz)

Measuring Uncertainty for a Level of Confidence of 95% ($U = 2Uc(y)$)	4.90
-------------------------------------------------------------------------	------



Appendix A. Conducted Test Results

<CDD Modes>

Test Engineer:	Derek Hsu	Temperature:	21~25	°C
Test Date:	2016/06/02~2016/07/09	Relative Humidity:	51~54	%

TEST RESULTS DATA
26dB and 99% OBW

Band I																
Mod.	Data Rate	NTX	CH.	Freq. (MHz)	26 dB Bandwidth (MHz)				99% Bandwidth (MHz)				IC 99% Bandwidth EIRP Limit (dBm)			
					Ant 1	Ant 2	Ant 3	Ant 4	Ant 1	Ant 2	Ant 3	Ant 4	Ant 1	Ant 2	Ant 3	Ant 4
11a	6Mbps	4	36	5180	20.87	20.69	20.55	21.14	17.15	17.10	17.15	17.20	22.34	22.33	22.34	22.36
11a	6Mbps	4	44	5220	21.19	20.94	20.88	21.15	17.20	17.20	17.15	17.10	22.36	22.36	22.34	22.33
11a	6Mbps	4	48	5240	21	21.20	20.66	20.76	17.20	17.10	17.15	17.15	22.36	22.33	22.34	22.34

Note: The 99% OBW edge frequency worse case is $5240 + (17.20/2) = 5248.6\text{MHz}$, which does not exceed 5250MHz.

TEST RESULTS DATA
Average Power Table

FCC Band I															
Mod.	Data Rate	NTX	CH.	Freq. (MHz)	Ant	Average Conducted Power with duty factor (dBm)					FCC Power Limit (dBm)	DG (dBi)	FCC EIRP Power (dBm)	FCC EIRP Power Limit (dBm)	Pass/Fail
						Ant 1	Ant 2	Ant 3	Ant 4	SUM					
11a	6Mbps	4	36	5180	+2+3+4	18.77	19.31	18.44	18.51	24.79	30.00	3.82	28.61	-	Pass
11a	6Mbps	4	44	5220	+2+3+4	18.52	19.03	19.23	19.08	24.99	30.00	3.82	28.81	-	Pass
11a	6Mbps	4	48	5240	+2+3+4	18.42	18.91	19.91	19.74	25.30	30.00	3.82	29.12	-	Pass
HT20	MCS0	4	36	5180	+2+3+4	15.45	15.90	15.01	15.11	21.40	30.00	3.82	25.22	-	Pass
HT20	MCS0	4	44	5220	+2+3+4	14.65	15.20	15.78	15.35	21.28	30.00	3.82	25.10	-	Pass
HT20	MCS0	4	48	5240	+2+3+4	13.92	14.38	14.90	14.71	20.51	30.00	3.82	24.33	-	Pass
HT40	MCS0	4	38	5190	+2+3+4	16.78	16.99	16.71	16.69	22.81	30.00	3.82	26.63	-	Pass
HT40	MCS0	4	46	5230	+2+3+4	17.46	17.70	18.51	18.24	24.02	30.00	3.82	27.84	-	Pass

TEST RESULTS DATA
Power Spectral Density

FCC Band I														
Mod.	Data Rate	NTX	CH.	Freq. (MHz)	Ant	Duty Factor (dB)				Average PSD with Duty Factor (dBm/MHz)	PSD Limit (dBm/MHz)	DG (dBi)		Pass /Fail
						Ant 1	Ant 2	Ant 3	Ant 4					
11a	6Mbps	2	36	5180	+2+3+4	0.17	0.17	0.17	0.17	12.87	13.78	9.22		Pass
11a	6Mbps	2	44	5220	+2+3+4	0.17	0.17	0.17	0.17	13.453	13.78	9.22		Pass
11a	6Mbps	2	48	5240	+2+3+4	0.17	0.17	0.17	0.17	13.773	13.78	9.22		Pass

TEST RESULTS DATA
Frequency Stability

Band I										
Mod.	Data Rate	NTX	CH.	Freq. (MHz)	Center Frequency (MHz)	Frequency Deviation (MHz)	Frequency Stability (ppm)	Temperature (°C)	Voltage (V)	Note
11a	6Mbps	1	36	5180	5180.050	0.050	9.65	20	99	
11a	6Mbps	1	36	5180	5180.050	0.050	9.65	20	121	
11a	6Mbps	1	36	5180	5180.050	0.050	9.65	20	110	
11a	6Mbps	1	36	5180	5180.150	0.150	28.96	-30	110	
11a	6Mbps	1	36	5180	5180.000	0.000	0.00	50	110	



<TXBF Modes>

Test Engineer:	Derek Hsu	Temperature:	21~25	°C
Test Date:	2016/06/02~2016/07/12	Relative Humidity:	51~54	%

TEST RESULTS DATA
26dB and 99% OBW

Band I																
Mod.	Data Rate	NTX	CH.	Freq. (MHz)	26 dB Bandwidth (MHz)				99% Bandwidth (MHz)				IC 99% Bandwidth EIRP Limit (dBm)			
					Ant 1	Ant 2	Ant 3	Ant 4	Ant 1	Ant 2	Ant 3	Ant 4	Ant 1	Ant 2	Ant 3	Ant 4
VHT20	MCS0	4	36	5180	25.38	24.70	23.10	24.96	18.80	18.75	18.75	18.90	22.74	22.73	22.73	22.76
VHT20	MCS0	4	44	5220	24.36	24.63	23.46	24.09	18.65	18.70	18.65	18.70	22.71	22.72	22.71	22.72
VHT20	MCS0	4	48	5240	24.12	24.91	25.10	23.51	18.80	18.90	18.85	18.90	22.74	22.76	22.75	22.76
VHT40	MCS0	4	38	5190	43.92	43.44	43.36	43.44	37.00	37.00	37.00	36.90	23.01	23.01	23.01	23.01
VHT40	MCS0	4	46	5230	43.32	43.65	42.66	43.32	36.70	36.90	36.90	36.70	23.01	23.01	23.01	23.01
VHT80	MCS0	4	42	5210	86.4	84.80	85.28	85.12	76.20	76.08	76.20	76.20	23.01	23.01	23.01	23.01

Note: For VHT20 mode, the 99% OBW edge frequency worse case is $5240+(18.90/2) = 5249.45\text{MHz}$, which does not exceed 5250MH;

Note: For VHT40 mode, the 99% OBW edge frequency worse case is $5230+(36.90/2) = 5248.45\text{MHz}$, which does not exceed 5250MH;

Note: For VHT80 mode, the 99% OBW edge frequency worse case is $5210+(76.20/2) = 5248.10\text{MHz}$, which does not exceed 5250MH;

TEST RESULTS DATA
Average Power Table

FCC Band I															
Mod.	Data Rate	NTX	CH.	Freq. (MHz)	Ant	Average Conducted Power (dBm)					FCC Power Limit (dBm)	DG (dBi)	FCC EIRP Power (dBm)	FCC EIRP Power Limit (dBm)	Pass/Fail
						Ant 1	Ant 2	Ant 3	Ant 4	SUM					
VHT20	MCS0	4	36	5180	1+2+3+4	13.10	12.90	13.80	13.40	19.33	26.78	9.22	28.55	-	Pass
VHT20	MCS0	4	44	5220	1+2+3+4	13.70	13.50	13.40	12.60	19.34	26.78	9.22	28.56	-	Pass
VHT20	MCS0	4	48	5240	1+2+3+4	14.60	13.90	12.60	12.20	19.45	26.78	9.22	28.67	-	Pass
VHT40	MCS0	4	38	5190	1+2+3+4	15.70	15.50	16.50	16.10	21.99	26.78	9.22	31.21	-	Pass
VHT40	MCS0	4	46	5230	1+2+3+4	16.20	16.20	15.30	14.60	21.65	26.78	9.22	30.87	-	Pass
VHT80	MCS0	4	42	5210	1+2+3+4	15.04	14.41	14.74	14.27	20.65	26.78	9.22	29.87	-	Pass

TEST RESULTS DATA
Power Spectral Density

FCC Band I														
Mod.	Data Rate	NTX	CH.	Freq. (MHz)	Ant	Average PSD (dB)				Combined Average PSD (dBm/MHz)	PSD Limit (dBm/MHz)	DG (dBi)		Pass /Fail
						Ant 1	Ant 2	Ant 3	Ant 4					
VHT20	MCS0	2	36	5180	1+2+3+4	-	-	-	-	13.5	13.78	9.22		Pass
VHT20	MCS0	2	44	5220	1+2+3+4	-	-	-	-	13.519	13.78	9.22		Pass
VHT20	MCS0	2	48	5240	1+2+3+4	-	-	-	-	13.635	13.78	9.22		Pass
VHT40	MCS0	2	38	5190	1+2+3+4	-	-	-	-	13.734	13.78	9.22		Pass
VHT40	MCS0	2	46	5230	1+2+3+4	-	-	-	-	13.657	13.78	9.22		Pass
VHT80	MCS0	2	42	5210	1+2+3+4	-	-	-	-	9.791	13.78	9.22		Pass



Appendix B. Radiated Spurious Emission

Test Engineer :	Tsung Lee and Stan Hsieh	Temperature :	25~26°C
		Relative Humidity :	48~49%

<CDD Mode>

Band 1 - 5150~5250MHz
WIFI 802.11a (Band Edge @ 3m)

WIFI Ant. 1+2	Note	Frequency (MHz)	Level (dBμV/m)	Over Limit (dB)	Limit Line (dBμV/m)	Read Level (dBμV)	Antenna Factor (dB/m)	Cable Loss (dB)	Preamp Factor (dB)	Ant Pos (cm)	Table Pos (deg)	Peak Avg. (P/A)	Pol. (H/V)	
802.11a CH 36 5180MHz		5149.25	53	-21	74	45.65	31.98	7.94	32.57	100	63	P	H	
		5147.25	45.53	-8.47	54	38.18	31.98	7.94	32.57	100	63	A	H	
	*	5182	112.75	-	-	105.39	32.02	7.91	32.57	100	63	P	H	
	*	5182	107.11	-	-	99.75	32.02	7.91	32.57	100	63	A	H	
													H	
														H
			5147.75	62.09	-11.91	74	54.74	31.98	7.94	32.57	100	280	P	V
			5147.25	53.73	-0.27	54	46.38	31.98	7.94	32.57	100	280	A	V
	*		5182	119.88	-	-	112.52	32.02	7.91	32.57	100	280	P	V
	*		5182	114.35	-	-	106.99	32.02	7.91	32.57	100	280	A	V
														V
														V
802.11a CH 44 5220MHz		5137.02	48.51	-25.49	74	41.18	31.96	7.94	32.57	100	64	P	H	
		5000.26	40.89	-13.11	54	33.61	31.8	8.05	32.57	100	64	A	H	
	*	5220	119.79	-	-	112.29	32.06	8.01	32.57	100	64	P	H	
	*	5220	112.1	-	-	104.6	32.06	8.01	32.57	100	64	A	H	
			5355	49.45	-24.55	74	41.57	32.22	8.23	32.57	100	64	P	H
			5379.12	40.45	-13.55	54	32.47	32.26	8.29	32.57	100	64	A	H
			5146.38	54.43	-19.57	74	47.08	31.98	7.94	32.57	100	283	P	V
			5141.18	46.32	-7.68	54	38.97	31.98	7.94	32.57	100	283	A	V
	*		5220	128.08	-	-	120.58	32.06	8.01	32.57	100	283	P	V
	*		5220	119.97	-	-	112.47	32.06	8.01	32.57	100	283	A	V
			5382	52.05	-21.95	74	44.07	32.26	8.29	32.57	100	283	P	V
			5375.88	44.44	-9.56	54	36.48	32.24	8.29	32.57	100	283	A	V



802.11a CH 48 5240MHz		5109.98	48.65	-25.35	74	41.32	31.94	7.96	32.57	100	118	P	H
		5144.56	39.74	-14.26	54	32.39	31.98	7.94	32.57	100	118	A	H
	*	5240	117.2	-	-	109.68	32.08	8.01	32.57	100	118	P	H
	*	5240	108.64	-	-	101.12	32.08	8.01	32.57	100	118	A	H
		5353.2	48.55	-25.45	74	40.67	32.22	8.23	32.57	100	118	P	H
		5350.32	40.39	-13.61	54	32.51	32.22	8.23	32.57	100	118	A	H
		5135.98	52.98	-21.02	74	45.65	31.96	7.94	32.57	100	281	P	V
		5000	46	-8	54	38.72	31.8	8.05	32.57	100	281	A	V
	*	5240	120.32	-	-	112.8	32.08	8.01	32.57	100	281	P	V
	*	5240	112.77	-	-	105.25	32.08	8.01	32.57	100	281	A	V
		5365.8	52.42	-21.58	74	44.46	32.24	8.29	32.57	100	281	P	V
		5352.3	44.25	-9.75	54	36.37	32.22	8.23	32.57	100	281	A	V
Remark	1. No other spurious found. 2. All results are PASS against Peak and Average limit line.												



Band 1 5150~5250MHz
WIFI 802.11a (Harmonic @ 3m)

WIFI Ant. 1+2	Note	Frequency (MHz)	Level (dBμV/m)	Over Limit (dB)	Limit Line (dBμV/m)	Read Level (dBμV)	Antenna Factor (dB/m)	Cable Loss (dB)	Preamp Factor (dB)	Ant Pos (cm)	Table Pos (deg)	Peak Avg. (P/A)	Pol. (H/V)
802.11a CH 36 5180MHz		10362	49.7	-24.3	74	48.95	39.69	11.96	50.9	100	0	P	H
		15540	49.32	-24.68	74	48.43	38.04	14.76	51.91	100	0	P	H
													H
													H
		10362	53.99	-20.01	74	53.24	39.69	11.96	50.9	374	276	P	V
		10362	44.2	-9.8	54	43.45	39.69	11.96	50.9	374	276	A	V
		15538	54.32	-19.68	74	53.43	38.04	14.76	51.91	338	267	P	V
		15538	44.45	-9.55	54	43.56	38.04	14.76	51.91	338	267	A	V
802.11a CH 44 5220MHz		10440	49.66	-24.34	74	48.74	39.79	12.03	50.9	100	0	P	H
		15660	56.21	-17.79	74	55.5	37.85	14.79	51.93	393	322	P	H
		15660	45.58	-8.42	54	44.87	37.85	14.79	51.93	393	322	A	H
													H
		10440	55.72	-18.28	74	54.8	39.79	12.03	50.9	100	29	P	V
		10440	45.7	-8.3	54	44.78	39.79	12.03	50.9	100	29	A	V
		15660	61.33	-12.67	74	60.62	37.85	14.79	51.93	195	298	P	V
		15660	51.02	-2.98	54	50.31	37.85	14.79	51.93	195	298	A	V
802.11a CH 48 5240MHz		10480	49.14	-24.86	74	48.11	39.87	12.06	50.9	100	0	P	H
		15720	53.19	-20.81	74	52.59	37.74	14.81	51.95	331	226	P	H
		15720	45.69	-8.31	54	45.09	37.74	14.81	51.95	331	226	A	H
													H
		10480	52.86	-21.14	74	51.83	39.87	12.06	50.9	100	32	P	V
		10480	44.91	-9.09	54	43.88	39.87	12.06	50.9	100	32	A	V
		15720	59.04	-14.96	74	58.44	37.74	14.81	51.95	215	299	P	V
		15720	51.01	-2.99	54	50.41	37.74	14.81	51.95	215	299	A	V
Remark	1. No other spurious found. 2. All results are PASS against Peak and Average limit line.												



Band 1 5150~5250MHz

Emission below 1GHz

WIFI 802.11a (LF @ 3m)

WIFI Ant.	Note	Frequency	Level	Over Limit	Limit Line	Read Level	Antenna Factor	Cable Loss	Preamp Factor	Ant Pos	Table Pos	Peak Avg.	Pol.	
1+2		(MHz)	(dBμV/m)	(dB)	(dBμV/m)	(dBμV)	(dB/m)	(dB)	(dB)	(cm)	(deg)	(P/A)	(H/V)	
802.11a LF		82.92	34	-6	40	51.49	14.26	0.93	32.68	-	-	P	H	
		180.39	38.4	-5.1	43.5	54.13	15.5	1.48	32.71	-	-	P	H	
		225.75	41.64	-4.36	46	56.07	16.68	1.62	32.73	100	25	P	H	
		300.7	40.04	-5.96	46	51.16	19.73	1.88	32.73	-	-	P	H	
		406.4	38.72	-7.28	46	46.9	22.51	2.16	32.85	-	-	P	H	
		650	39.25	-6.75	46	43.59	26	2.67	33.01	-	-	P	H	
														H
														H
														H
														H
														H
														H
			41.07	34.33	-5.67	40	46.54	19.94	0.65	32.8	-	-	P	V
			81.03	35.77	-4.23	40	53.51	14.02	0.93	32.69	100	57	P	V
			181.47	35.82	-7.68	43.5	51.54	15.51	1.48	32.71	-	-	P	V
			300	36.03	-9.97	46	47.18	19.7	1.88	32.73	-	-	P	V
			562.5	35.46	-10.54	46	41.23	24.75	2.47	32.99	-	-	P	V
			650	37.74	-8.26	46	42.08	26	2.67	33.01	-	-	P	V
													V	
													V	
													V	
													V	
													V	
													V	
Remark	1. No other spurious found. 2. All results are PASS against limit line.													



Note symbol

*	Fundamental Frequency which can be ignored. However, the level of any unwanted emissions shall not exceed the level of the fundamental frequency.
!	Test result is over limit line.
P/A	Peak or Average
H/V	Horizontal or Vertical



A calculation example for radiated spurious emission is shown as below:

WIFI	Note	Frequency	Level	Over	Limit	Read	Antenna	Cable	Preamp	Ant	Table	Peak	Pol.
Ant.				Limit	Line	Level	Factor	Loss	Factor	Pos	Pos	Avg.	
1+2		(MHz)	(dBμV/m)	(dB)	(dBμV/m)	(dBμV)	(dB/m)	(dB)	(dB)	(cm)	(deg)	(P/A)	(H/V)
802.11b		2390	55.45	-18.55	74	54.51	32.22	4.58	35.86	103	308	P	H
CH 01													
2412MHz		2390	43.54	-10.46	54	42.6	32.22	4.58	35.86	103	308	A	H

- Level(dBμV/m) =
Antenna Factor(dB/m) + Cable Loss(dB) + Read Level(dBμV) - Preamp Factor(dB)
- Over Limit(dB) = Level(dBμV/m) – Limit Line(dBμV/m)

For Peak Limit @ 2390MHz:

- Level(dBμV/m)
= Antenna Factor(dB/m) + Cable Loss(dB) + Read Level(dBμV) - Preamp Factor(dB)
= 32.22(dB/m) + 4.58(dB) + 54.51(dBμV) – 35.86 (dB)
= 55.45 (dBμV/m)
- Over Limit(dB)
= Level(dBμV/m) – Limit Line(dBμV/m)
= 55.45(dBμV/m) – 74(dBμV/m)
= -18.55(dB)

For Average Limit @ 2390MHz:

- Level(dBμV/m)
= Antenna Factor(dB/m) + Cable Loss(dB) + Read Level(dBμV) - Preamp Factor(dB)
= 32.22(dB/m) + 4.58(dB) + 42.6(dBμV) – 35.86 (dB)
= 43.54 (dBμV/m)
- Over Limit(dB)
= Level(dBμV/m) – Limit Line(dBμV/m)
= 43.54(dBμV/m) – 54(dBμV/m)
= -10.46(dB)

Both peak and average measured complies with the limit line, so test result is “PASS”.



<TXBF Modes>

Band 1 - 5150~5250MHz

WIFI 802.11ac VHT20 (Band Edge @ 3m)

WIFI Ant.	Note	Frequency (MHz)	Level (dBμV/m)	Over Limit (dB)	Limit Line (dBμV/m)	Read Level (dBμV)	Antenna Factor (dB/m)	Cable Loss (dB)	Preamp Factor (dB)	Ant Pos (cm)	Table Pos (deg)	Peak Avg. (P/A)	Pol. (H/V)	
802.11ac VHT20 CH 36 5180MHz		5133.64	52.29	-21.71	74	44.96	31.96	7.94	32.57	100	302	P	H	
		5000	46.01	-7.99	54	38.73	31.8	8.05	32.57	100	302	A	H	
	*	5180	111.32	-	-	103.96	32.02	7.91	32.57	100	302	P	H	
	*	5180	103.28	-	-	95.92	32.02	7.91	32.57	100	302	A	H	
													H	
														H
			5140.4	55.59	-18.41	74	48.24	31.98	7.94	32.57	100	305	P	V
			5150	49.42	-4.58	54	42.07	31.98	7.94	32.57	100	305	A	V
		*	5180	114.34	-	-	106.98	32.02	7.91	32.57	100	305	P	V
		*	5180	105.87	-	-	98.51	32.02	7.91	32.57	100	305	A	V
													V	
													V	
802.11ac VHT20 CH 44 5220MHz		5144.04	49.64	-24.36	74	42.29	31.98	7.94	32.57	100	220	P	H	
		5000	42.61	-11.39	54	35.33	31.8	8.05	32.57	100	220	A	H	
	*	5220	109.4	-	-	101.9	32.06	8.01	32.57	100	220	P	H	
	*	5220	102.79	-	-	95.29	32.06	8.01	32.57	100	220	A	H	
			5354.16	48.77	-25.23	74	40.89	32.22	8.23	32.57	100	220	P	H
			5351.76	41.03	-12.97	54	33.15	32.22	8.23	32.57	100	220	A	H
			5149.5	53.51	-20.49	74	46.16	31.98	7.94	32.57	100	280	P	V
			5000	46.12	-7.88	54	38.84	31.8	8.05	32.57	100	280	A	V
		*	5220	116.91	-	-	109.41	32.06	8.01	32.57	100	280	P	V
		*	5220	108.57	-	-	101.07	32.06	8.01	32.57	100	280	A	V
		5382.48	54.94	-19.06	74	46.96	32.26	8.29	32.57	100	280	P	V	
		5350.56	46.07	-7.93	54	38.19	32.22	8.23	32.57	100	280	A	V	



802.11ac VHT20 CH 48 5240MHz		5000.26	49.69	-24.31	74	42.41	31.8	8.05	32.57	100	298	P	H
		5000	46.18	-7.82	54	38.9	31.8	8.05	32.57	100	298	A	H
	*	5240	109.62	-	-	102.1	32.08	8.01	32.57	100	298	P	H
	*	5240	101.99	-	-	94.47	32.08	8.01	32.57	100	298	A	H
		5402.64	50.66	-23.34	74	42.66	32.28	8.29	32.57	100	298	P	H
		5352.96	42.46	-11.54	54	34.58	32.22	8.23	32.57	100	298	A	H
		5135.98	52.27	-21.73	74	44.94	31.96	7.94	32.57	100	277	P	V
		5140.14	43.45	-10.55	54	36.1	31.98	7.94	32.57	100	277	A	V
	*	5240	113.48	-	-	105.96	32.08	8.01	32.57	100	277	P	V
	*	5240	107.58	-	-	100.06	32.08	8.01	32.57	100	277	A	V
		5442.72	53.62	-20.38	74	45.58	32.32	8.29	32.57	100	277	P	V
		5352.48	45.69	-8.31	54	37.81	32.22	8.23	32.57	100	277	A	V
Remark	1. No other spurious found. 2. All results are PASS against Peak and Average limit line.												



Band 1 5150~5250MHz
WIFI 802.11ac VHT20 (Harmonic @ 3m)

WIFI Ant. 1	Note	Frequency (MHz)	Level (dBμV/m)	Over Limit (dB)	Limit Line (dBμV/m)	Read Level (dBμV)	Antenna Factor (dB/m)	Cable Loss (dB)	Preamp Factor (dB)	Ant Pos (cm)	Table Pos (deg)	Peak Avg. (P/A)	Pol. (H/V)	
802.11ac VHT20 CH 36 5180MHz		10360	48.58	-25.42	74	47.83	39.69	11.96	50.9	100	0	P	H	
		15540	50.14	-23.86	74	49.25	38.04	14.76	51.91	100	0	P	H	
													H	
													H	
			10360	48.84	-25.16	74	48.09	39.69	11.96	50.9	100	0	P	V
			15540	55.75	-18.25	74	54.86	38.04	14.76	51.91	100	298	P	V
			15540	45.58	-8.42	54	44.69	38.04	14.76	51.91	100	298	A	V
													V	
802.11ac VHT20 CH 44 5220MHz		10440	48.61	-25.39	74	47.69	39.79	12.03	50.9	100	0	P	H	
		15660	49.66	-24.34	74	48.95	37.85	14.79	51.93	100	0	P	H	
													H	
													H	
			10440	48.87	-25.13	74	47.95	39.79	12.03	50.9	100	0	P	V
			15662	55.36	-18.64	74	54.66	37.85	14.79	51.94	295	296	P	V
			15662	46.04	-7.96	54	45.34	37.85	14.79	51.94	295	296	A	V
													V	
802.11ac VHT20 CH 48 5240MHz		10480	48.53	-25.47	74	47.5	39.87	12.06	50.9	100	0	P	H	
		15720	49.63	-24.37	74	49.03	37.74	14.81	51.95	100	0	P	H	
													H	
													H	
			10480	49.87	-24.13	74	48.84	39.87	12.06	50.9	100	0	P	V
			15718	55.96	-18.04	74	55.36	37.74	14.81	51.95	272	296	P	V
			15718	46.28	-7.72	54	45.68	37.74	14.81	51.95	272	296	A	V
													V	
Remark	1. No other spurious found. 2. All results are PASS against Peak and Average limit line.													



Band 1 5150~5250MHz
WIFI 802.11ac VHT40 (Band Edge @ 3m)

WIFI Ant. 1	Note	Frequency (MHz)	Level (dBμV/m)	Over Limit (dB)	Limit Line (dBμV/m)	Read Level (dBμV)	Antenna Factor (dB/m)	Cable Loss (dB)	Preamp Factor (dB)	Ant Pos (cm)	Table Pos (deg)	Peak Avg. (P/A)	Pol. (H/V)
802.11ac VHT40 CH 38 5190MHz		5149.24	55.25	-18.75	74	47.9	31.98	7.94	32.57	100	291	P	H
		5150	47.09	-6.91	54	39.74	31.98	7.94	32.57	100	291	P	H
	*	5188	105.12	-	-	97.76	32.02	7.91	32.57	100	291	P	H
	*	5188	98.14	-	-	90.78	32.02	7.91	32.57	100	291	A	H
		5357.76	48.71	-25.29	74	40.83	32.22	8.23	32.57	100	291	P	H
		5358.48	40.82	-13.18	54	32.94	32.22	8.23	32.57	100	291	A	H
		5148.98	61.78	-12.22	74	54.43	31.98	7.94	32.57	100	242	P	V
		5149.76	53.77	-0.23	54	46.42	31.98	7.94	32.57	100	242	A	V
	*	5192	111.84	-	-	104.46	32.04	7.91	32.57	100	242	P	V
	*	5192	104.97	-	-	97.59	32.04	7.91	32.57	100	242	A	V
		5394.96	52.4	-21.6	74	44.4	32.28	8.29	32.57	100	242	P	V
		5350.8	44	-10	54	36.12	32.22	8.23	32.57	100	242	A	V
802.11ac VHT40 CH 46 5230MHz		5147.94	50.58	-23.42	74	43.23	31.98	7.94	32.57	100	299	P	H
		5000	45.95	-8.05	54	38.67	31.8	8.05	32.57	100	299	A	H
	*	5228	108.55	-	-	101.03	32.08	8.01	32.57	100	299	P	H
	*	5228	102.16	-	-	94.64	32.08	8.01	32.57	100	299	A	H
		5407.44	50.59	-23.41	74	42.59	32.28	8.29	32.57	100	299	P	H
		5354.64	42.31	-11.69	54	34.43	32.22	8.23	32.57	100	299	A	H
		5148.98	54.17	-19.83	74	46.82	31.98	7.94	32.57	100	241	P	V
		5150	46.97	-7.03	54	39.62	31.98	7.94	32.57	100	241	A	V
	*	5232	113.74	-	-	106.22	32.08	8.01	32.57	100	241	P	V
	*	5232	107.07	-	-	99.55	32.08	8.01	32.57	100	241	A	V
	5371.92	53.56	-20.44	74	45.6	32.24	8.29	32.57	100	241	P	V	
	5351.04	45.98	-8.02	54	38.1	32.22	8.23	32.57	100	241	A	V	
Remark	1. No other spurious found. 2. All results are PASS against Peak and Average limit line.												



Band 1 5150~5250MHz
WIFI 802.11ac VHT40 (Harmonic @ 3m)

WIFI Ant. 1	Note	Frequency (MHz)	Level (dBμV/m)	Over Limit (dB)	Limit Line (dBμV/m)	Read Level (dBμV)	Antenna Factor (dB/m)	Cable Loss (dB)	Preamp Factor (dB)	Ant Pos (cm)	Table Pos (deg)	Peak Avg. (P/A)	Pol. (H/V)	
802.11ac VHT40 CH 38 5190MHz		10380	48.83	-25.17	74	48.06	39.71	11.96	50.9	100	0	P	H	
		15570	49.1	-24.9	74	48.26	37.99	14.77	51.92	100	0	P	H	
													H	
													H	
			10380	48.34	-25.66	74	47.57	39.71	11.96	50.9	100	0	P	V
			15570	52.23	-21.77	74	51.39	37.99	14.77	51.92	294	296	P	V
			15570	44.69	-9.31	54	43.85	37.99	14.77	51.92	294	296	A	V
													V	
802.11ac VHT40 CH 46 5230MHz		10460	48.29	-25.71	74	47.34	39.82	12.03	50.9	100	0	P	H	
		15690	48.93	-25.07	74	48.27	37.8	14.8	51.94	100	0	P	H	
													H	
													H	
			10460	48.73	-25.27	74	47.78	39.82	12.03	50.9	100	0	P	V
			15690	52.8	-21.2	74	52.14	37.8	14.8	51.94	300	297	P	V
			15690	44.11	-9.89	54	43.45	37.8	14.8	51.94	300	297	A	V
													V	
Remark	1. No other spurious found. 2. All results are PASS against Peak and Average limit line.													



Band 1 5150~5250MHz
WIFI 802.11ac VHT80 (Band Edge @ 3m)

WIFI Ant. 1	Note	Frequency (MHz)	Level (dBμV/m)	Over Limit (dB)	Limit Line (dBμV/m)	Read Level (dBμV)	Antenna Factor (dB/m)	Cable Loss (dB)	Preamp Factor (dB)	Ant Pos (cm)	Table Pos (deg)	Peak Avg. (P/A)	Pol. (H/V)
802.11ac VHT80 CH 42 5210MHz		5135.46	54.27	-19.73	74	46.94	31.96	7.94	32.57	100	289	P	H
		5149.5	46.79	-7.21	54	39.44	31.98	7.94	32.57	100	289	A	H
	*	5212	101.79	-	-	94.29	32.06	8.01	32.57	100	289	P	H
	*	5212	95.08	-	-	87.58	32.06	8.01	32.57	100	289	A	H
		5372.88	51.29	-22.71	74	43.33	32.24	8.29	32.57	100	289	P	H
		5352	41.66	-12.34	54	33.78	32.22	8.23	32.57	100	289	A	H
		5139.88	58.04	-15.96	74	50.69	31.98	7.94	32.57	100	260	P	V
		5150	51.58	-2.42	54	44.23	31.98	7.94	32.57	100	260	A	V
	*	5212	106.64	-	-	99.14	32.06	8.01	32.57	100	260	P	V
	*	5212	99.99	-	-	92.49	32.06	8.01	32.57	100	260	A	V
		5380.56	56.55	-17.45	74	48.57	32.26	8.29	32.57	100	260	P	V
	5352.96	47.28	-6.72	54	39.4	32.22	8.23	32.57	100	260	A	V	
Remark	1. No other spurious found. 2. All results are PASS against Peak and Average limit line.												



Band 1 5150~5250MHz
WIFI 802.11ac VHT80 (Harmonic @ 3m)

WIFI Ant. 1	Note	Frequency (MHz)	Level (dBμV/m)	Over Limit (dB)	Limit Line (dBμV/m)	Read Level (dBμV)	Antenna Factor (dB/m)	Cable Loss (dB)	Preamp Factor (dB)	Ant Pos (cm)	Table Pos (deg)	Peak Avg. (P/A)	Pol. (H/V)	
802.11ac VHT80 CH 42 5210MHz		10420	48.56	-25.44	74	47.69	39.77	12	50.9	100	0	P	H	
		15630	48.93	-25.07	74	48.2	37.88	14.78	51.93	100	0	P	H	
													H	
													H	
			10420	49.59	-24.41	74	48.72	39.77	12	50.9	100	0	P	V
			15630	49.85	-24.15	74	49.12	37.88	14.78	51.93	100	0	P	V
														V
														V
Remark	1. No other spurious found. 2. All results are PASS against Peak and Average limit line.													



Emission below 1GHz
WIFI 802.11ac VHT20 (LF @ 3m)

WIFI	Note	Frequency	Level	Over	Limit	Read	Antenna	Cable	Preamp	Ant	Table	Peak	Pol.	
Ant.				Limit	Line	Level	Factor	Loss	Factor	Pos	Pos	Avg.		
1		(MHz)	(dBμV/m)	(dB)	(dBμV/m)	(dBμV)	(dB/m)	(dB)	(dB)	(cm)	(deg)	(P/A)	(H/V)	
802.11ac VHT20 LF		77.2	36.44	-3.56	40	54.66	13.55	0.93	32.7	400	90	QP	H	
		77.2	38.07	-1.93	40	56.29	13.55	0.93	32.7	400	90	P	H	
		125.04	37.98	-5.52	43.5	51.41	17.9	1.33	32.66			P	H	
		228.99	41.13	-4.87	46	55.32	16.92	1.62	32.73			P	H	
		386.1	37.9	-8.1	46	46.53	22.07	2.13	32.83			P	H	
		485.5	35.99	-10.01	46	42.66	23.91	2.33	32.91			P	H	
		650	39.83	-6.17	46	44.17	26	2.67	33.01			P	H	
														H
														H
														H
														H
														H
			47.82	39.01	-0.99	40	54.41	16.45	0.93	32.78	106	0	QP	V
		*	47.82	44.85	4.85	40	60.25	16.45	0.93	32.78	106	0	P	V
			77.52	38.37	-1.63	40	56.59	13.55	0.93	32.7	100	110	QP	V
			77.52	39.82	-0.18	40	58.04	13.55	0.93	32.7	100	110	P	V
			283.26	42.34	-3.66	46	53.92	19.39	1.76	32.73			P	V
			372.1	34.01	-11.99	46	42.95	21.74	2.13	32.81			P	V
			481.3	35.27	-10.73	46	42.05	23.82	2.3	32.9			P	V
			650	38.5	-7.5	46	42.84	26	2.67	33.01			P	V
													V	
													V	
													V	
													V	
Remark	1. No other spurious found. 2. All results are PASS against limit line.													



Emission below 1GHz
WIFI 802.11ac VHT40 (LF @ 3m)

WIFI	Note	Frequency	Level	Over	Limit	Read	Antenna	Cable	Preamp	Ant	Table	Peak	Pol.	
Ant.				Limit	Line	Level	Factor	Loss	Factor	Pos	Pos	Avg.		
1		(MHz)	(dBμV/m)	(dB)	(dBμV/m)	(dBμV)	(dB/m)	(dB)	(dB)	(cm)	(deg)	(P/A)	(H/V)	
802.11ac VHT40 LF		78.33	37.01	-2.99	40	55.12	13.66	0.93	32.7	245	83	QP	H	
		78.33	39.28	-0.72	40	57.39	13.66	0.93	32.7	245	83	P	H	
		125.04	37.88	-5.62	43.5	51.31	17.9	1.33	32.66			P	H	
		281.1	40.95	-5.05	46	52.59	19.33	1.76	32.73			P	H	
		381.2	38.73	-7.27	46	47.47	21.95	2.13	32.82			P	H	
		477.8	37.49	-8.51	46	44.33	23.76	2.3	32.9			P	H	
		650	40.6	-5.4	46	44.94	26	2.67	33.01			P	H	
														H
														H
														H
														H
														H
			48.9	38.05	-1.95	40	53.87	16.03	0.93	32.78	107	360	QP	V
		*	48.9	43.37	3.37	40	59.19	16.03	0.93	32.78	107	360	P	V
			77.25	38.22	-1.78	40	56.44	13.55	0.93	32.7	100	89	QP	V
			77.25	39.23	-0.77	40	57.45	13.55	0.93	32.7	100	89	P	V
			148.26	38.63	-4.87	43.5	52.23	17.75	1.33	32.68			P	V
			480.6	35.9	-10.1	46	42.68	23.82	2.3	32.9			P	V
			598.2	35.2	-10.8	46	40.2	25.46	2.57	33.03			P	V
			650	38.38	-7.62	46	42.72	26	2.67	33.01			P	V
													V	
													V	
													V	
													V	
Remark	1. No other spurious found. 2. All results are PASS against limit line.													



Emission below 1GHz
WIFI 802.11ac VHT80 (LF @ 3m)

WIFI	Note	Frequency	Level	Over	Limit	Read	Antenna	Cable	Preamp	Ant	Table	Peak	Pol.	
Ant.				Limit	Line	Level	Factor	Loss	Factor	Pos	Pos	Avg.		
1		(MHz)	(dBμV/m)	(dB)	(dBμV/m)	(dBμV)	(dB/m)	(dB)	(dB)	(cm)	(deg)	(P/A)	(H/V)	
802.11ac VHT80 LF		78.33	36.79	-3.21	40	54.9	13.66	0.93	32.7	275	91	QP	H	
		78.33	38.84	-1.16	40	56.95	13.66	0.93	32.7	275	91	P	H	
		125.04	37.73	-5.77	43.5	51.16	17.9	1.33	32.66			P	H	
		281.91	40.91	-5.09	46	52.52	19.36	1.76	32.73			P	H	
		384	37.9	-8.1	46	46.57	22.02	2.13	32.82			P	H	
		477.8	38.01	-7.99	46	44.85	23.76	2.3	32.9			P	H	
		650	39.6	-6.4	46	43.94	26	2.67	33.01			P	H	
														H
														H
														H
														H
														H
			47.82	38.69	-1.31	40	54.09	16.45	0.93	32.78	100	0	QP	V
		*	47.82	43.22	3.22	40	58.62	16.45	0.93	32.78	100	0	P	V
			76.98	36.95	-3.05	40	55.29	13.43	0.93	32.7	100	91	QP	V
		*	76.98	40.85	0.85	40	59.19	13.43	0.93	32.7	100	91	P	V
			280.56	41.4	-4.6	46	53.07	19.3	1.76	32.73			P	V
			476.4	34.38	-11.62	46	41.26	23.72	2.3	32.9			P	V
			596.8	34.08	-11.92	46	39.12	25.42	2.57	33.03			P	V
			650	38.29	-7.71	46	42.63	26	2.67	33.01			P	V
													V	
													V	
													V	
													V	
Remark	1. No other spurious found. 2. All results are PASS against limit line.													



Note symbol

*	Fundamental Frequency which can be ignored. However, the level of any unwanted emissions shall not exceed the level of the fundamental frequency.
!	Test result is over limit line.
P/A	Peak or Average
H/V	Horizontal or Vertical



A calculation example for radiated spurious emission is shown as below:

WIFI	Note	Frequency	Level	Over	Limit	Read	Antenna	Cable	Preamp	Ant	Table	Peak	Pol.
Ant.				Limit	Line	Level	Factor	Loss	Factor	Pos	Pos	Avg.	
1		(MHz)	(dBμV/m)	(dB)	(dBμV/m)	(dBμV)	(dB/m)	(dB)	(dB)	(cm)	(deg)	(P/A)	(H/V)
802.11b		2390	55.45	-18.55	74	54.51	32.22	4.58	35.86	103	308	P	H
CH 01													
2412MHz		2390	43.54	-10.46	54	42.6	32.22	4.58	35.86	103	308	A	H

- Level(dBμV/m) =
Antenna Factor(dB/m) + Cable Loss(dB) + Read Level(dBμV) - Preamp Factor(dB)
- Over Limit(dB) = Level(dBμV/m) – Limit Line(dBμV/m)

For Peak Limit @ 2390MHz:

- Level(dBμV/m)
= Antenna Factor(dB/m) + Cable Loss(dB) + Read Level(dBμV) - Preamp Factor(dB)
= 32.22(dB/m) + 4.58(dB) + 54.51(dBμV) – 35.86 (dB)
= 55.45 (dBμV/m)
- Over Limit(dB)
= Level(dBμV/m) – Limit Line(dBμV/m)
= 55.45(dBμV/m) – 74(dBμV/m)
= -18.55(dB)

For Average Limit @ 2390MHz:

- Level(dBμV/m)
= Antenna Factor(dB/m) + Cable Loss(dB) + Read Level(dBμV) - Preamp Factor(dB)
= 32.22(dB/m) + 4.58(dB) + 42.6(dBμV) – 35.86 (dB)
= 43.54 (dBμV/m)
- Over Limit(dB)
= Level(dBμV/m) – Limit Line(dBμV/m)
= 43.54(dBμV/m) – 54(dBμV/m)
= -10.46(dB)

Both peak and average measured complies with the limit line, so test result is “PASS”.



Appendix C. Radiated Spurious Emission

Note symbol

-L	Low channel location
-R	High channel location



<CDD Mode>

Band 1 - 5150~5250MHz

WIFI 802.11a (Band Edge @ 3m)

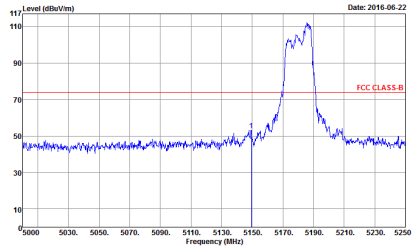
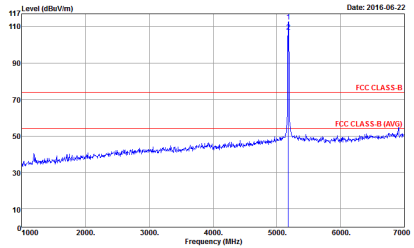
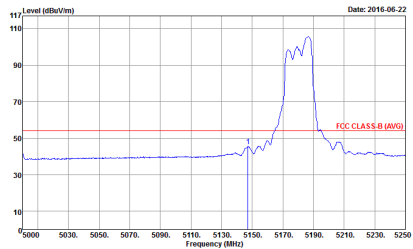
WIFI	Band 1 5150~5250MHz Band Edge @ 3m	
ANT	802.11a CH36 5180MHz	
1+2	Horizontal	Fundamental
Peak	 <p>Date: 2016-06-22</p> <p>Site : 03CH10-HY Condition : FCC CLASS-B 3m HORN 9120D-HF HORIZONTAL Detector : Peak Project : 652049 Mode : 1</p>	 <p>Date: 2016-06-22</p> <p>Site : 03CH10-HY Condition : FCC CLASS-B 3m HORN 9120D-HF HORIZONTAL Detector : Peak Project : 652049 Mode : 1</p>
Avg.	 <p>Date: 2016-06-22</p> <p>Site : 03CH10-HY Condition : FCC CLASS-B (AVG) 3m HORN 9120D-HF HORIZONTAL Detector : Peak Project : 652049 Mode : 1</p>	

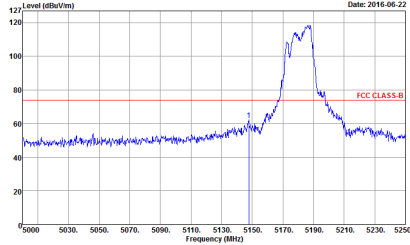
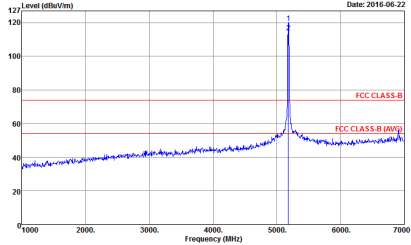
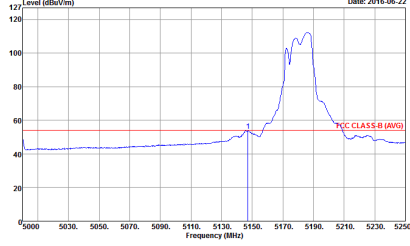

WIFI	Band 1 5150~5250MHz Band Edge @ 3m	
ANT	802.11a CH36 5180MHz	
1+2	Vertical	Fundamental
Peak	 <p>Date: 2016-06-22</p> <p>Site : 03CH10-HY Condition : FCC CLASS-B 3m HORN 9120D-HF VERTICAL RBW:1000.000KHz VBW:3000.000KHz SWT:Auto Detector : Peak Project : 652049 Mode : 1</p>	 <p>Date: 2016-06-22</p> <p>Site : 03CH10-HY Condition : FCC CLASS-B 3m HORN 9120D-HF VERTICAL RBW:1000.000KHz VBW:3000.000KHz SWT:Auto Detector : Peak Project : 652049 Mode : 1</p>
Avg.	 <p>Date: 2016-06-22</p> <p>Site : 03CH10-HY Condition : FCC CLASS-B (AVG) 3m HORN 9120D-HF VERTICAL RBW:1000.000KHz VBW:1.000KHz SWT:Auto Detector : Peak Project : 652049 Mode : 1</p>	

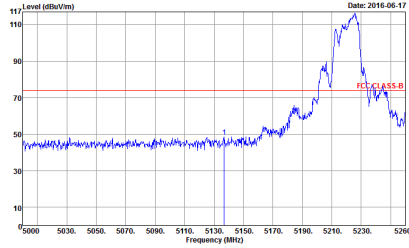
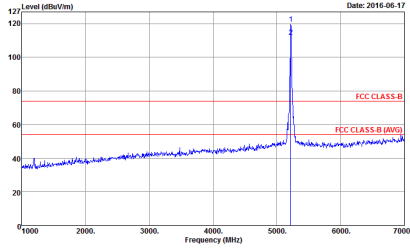
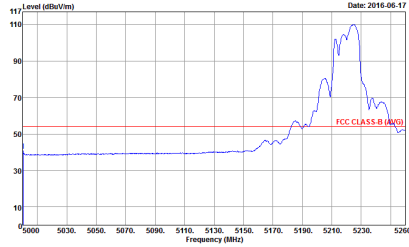

WIFI	Band 1 5150~5250MHz Band Edge @ 3m	
ANT	802.11a CH44 5220MHz - L	
1+2	Horizontal	Fundamental
Peak	 <p>Date: 2016-06-17</p> <p>Site : 03CH10-HY Condition : FCC CLASS-B 3m HORN 9120D-HF HORIZONTAL RBW:1000.000KHz VBW:3000.000KHz SWT:Auto Detector : Peak Project : 652049 Mode : 2</p>	 <p>Date: 2016-06-17</p> <p>Site : 03CH10-HY Condition : FCC CLASS-B 3m HORN 9120D-HF HORIZONTAL RBW:1000.000KHz VBW:3000.000KHz SWT:Auto Detector : Peak Project : 652049 Mode : 2</p>
Avg.	 <p>Date: 2016-06-17</p> <p>Site : 03CH10-HY Condition : FCC CLASS-B (AVG) 3m HORN 9120D-HF HORIZONTAL RBW:1000.000KHz VBW:1.000KHz SWT:Auto Detector : Peak Project : 652049 Mode : 2</p>	

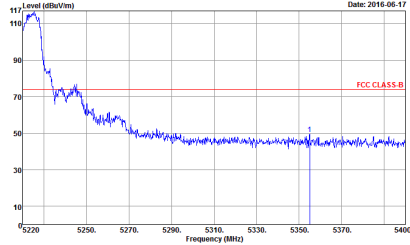
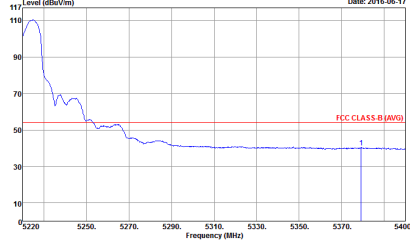

WIFI	Band 1 5150~5250MHz Band Edge @ 3m	
ANT	802.11a CH44 5220MHz - R	
1+2	Horizontal	
Peak	 <p>Date: 2016.06.17</p> <p>Site : 03CH10-HY Condition : FCC CLASS-B 3m HORN 9120D-HF HORIZONTAL Detector : Peak Project : 652049 Mode : 2</p>	
Avg.	 <p>Date: 2016.06.17</p> <p>Site : 03CH10-HY Condition : FCC CLASS-B (AVG) 3m HORN 9120D-HF HORIZONTAL Detector : Peak Project : 652049 Mode : 2</p>	

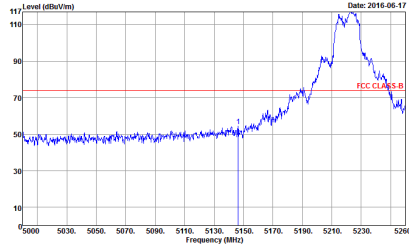
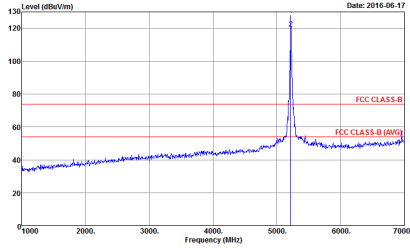
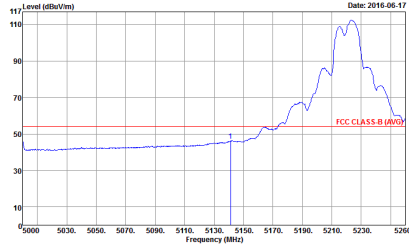

WIFI	Band 1 5150~5250MHz Band Edge @ 3m	
ANT	802.11a CH44 5220MHz - L	
1+2	Vertical	Fundamental
Peak	 <p>Date: 2016-06-17</p> <p>Level (dBuV/m) vs Frequency (MHz)</p> <p>Site : 03CH10-HY Condition : FCC CLASS-B 3m HORN 9120D-HF VERTICAL RBW:1000.000KHz VBW:3000.000KHz SWT:Auto Detector : Peak Project : 652049 Mode : 2</p>	 <p>Date: 2016-06-17</p> <p>Level (dBuV/m) vs Frequency (MHz)</p> <p>Site : 03CH10-HY Condition : FCC CLASS-B 3m HORN 9120D-HF VERTICAL RBW:1000.000KHz VBW:3000.000KHz SWT:Auto Detector : Peak Project : 652049 Mode : 2</p>
Avg.	 <p>Date: 2016-06-17</p> <p>Level (dBuV/m) vs Frequency (MHz)</p> <p>Site : 03CH10-HY Condition : FCC CLASS-B (AVG) 3m HORN 9120D-HF VERTICAL RBW:1000.000KHz VBW:1.000KHz SWT:Auto Detector : Peak Project : 652049 Mode : 2</p>	

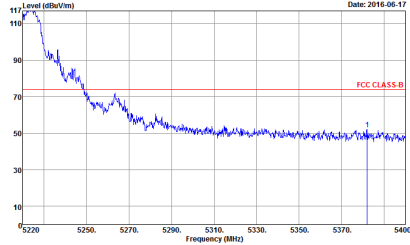
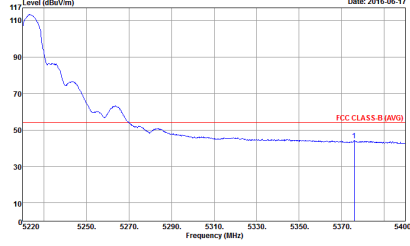

WIFI	Band 1 5150~5250MHz Band Edge @ 3m	
ANT	802.11a CH44 5220MHz - R	
1+2	Vertical	
Peak	 <p>Date: 2016.06.17</p> <p>Site : 03CH10-HY Condition : FCC CLASS-B 3m HORN 9120D-HF VERTICAL RBW:1000.000KHz VBW:3000.000KHz SWT:Auto Detector : Peak Project : 652049 Mode : 2</p>	
Avg.	 <p>Date: 2016.06.17</p> <p>Site : 03CH10-HY Condition : FCC CLASS-B (AVG) 3m HORN 9120D-HF VERTICAL RBW:1000.000KHz VBW:1.000KHz SWT:Auto Detector : Peak Project : 652049 Mode : 2</p>	



WIFI	Band 1 5150~5250MHz Band Edge @ 3m	
ANT	802.11a CH48 5240MHz - L	
1+2	Horizontal	Fundamental
Peak	<p> Site : 03CH10-HY Condition : FCC CLASS-B 3m HORN 9120D-HF HORIZONTAL : RBW:1000.000KHz VBW:3000.000KHz SWT:Auto Detector : Peak Project : 652049 Mode : 3 </p>	<p> Site : 03CH10-HY Condition : FCC CLASS-B 3m HORN 9120D-HF HORIZONTAL : RBW:1000.000KHz VBW:3000.000KHz SWT:Auto Detector : Peak Project : 652049 Mode : 3 </p>
Avg.	<p> Site : 03CH10-HY Condition : FCC CLASS-B (AVG) 3m HORN 9120D-HF HORIZONTAL : RBW:1000.000KHz VBW:1.000KHz SWT:Auto Detector : Peak Project : 652049 Mode : 3 </p>	

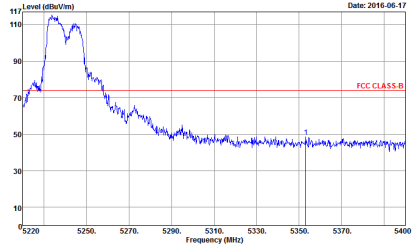
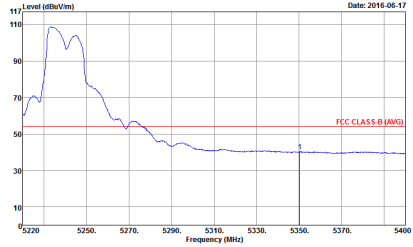

WIFI	Band 1 5150~5250MHz Band Edge @ 3m	
ANT	802.11a CH48 5240MHz - R	
1+2	Horizontal	
Peak	 <p>Date: 2016.06.17</p> <p>Site : 03CH10-HY Condition : FCC CLASS-B 3m HORN 9120D-HF HORIZONTAL : RBW:1000.000KHz VBW:3000.000KHz SWT:Auto Detector : Peak Project : 652049 Mode : 3</p>	
Avg.	 <p>Date: 2016.06.17</p> <p>Site : 03CH10-HY Condition : FCC CLASS-B (AVG) 3m HORN 9120D-HF HORIZONTAL : RBW:1000.000KHz VBW:1.000KHz SWT:Auto Detector : Peak Project : 652049 Mode : 3</p>	

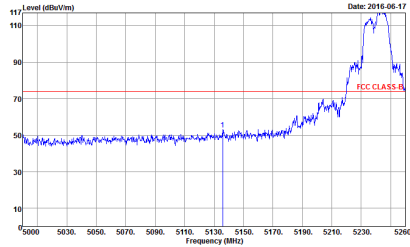
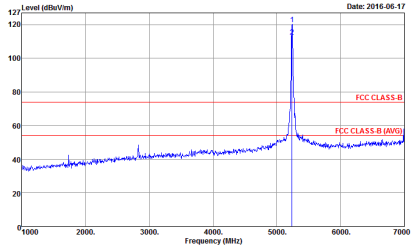
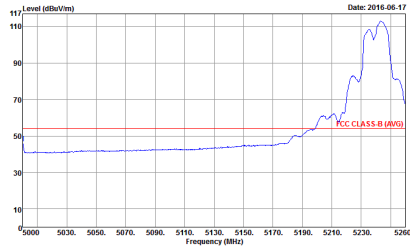

WIFI	Band 1 5150~5250MHz Band Edge @ 3m	
ANT	802.11a CH48 5240MHz - L	
1+2	Vertical	Fundamental
<p>Peak</p>	 <p>Site : 03CH10-HY Condition : FCC CLASS-B 3m HORN 9120D-HF VERTICAL Detector : Peak Project : 652049 Mode : 3</p>	 <p>Site : 03CH10-HY Condition : FCC CLASS-B 3m HORN 9120D-HF VERTICAL Detector : Peak Project : 652049 Mode : 3</p>
<p>Avg.</p>	 <p>Site : 03CH10-HY Condition : FCC CLASS-B (AVG) 3m HORN 9120D-HF VERTICAL Detector : Peak Project : 652049 Mode : 3</p>	



WIFI	Band 1 5150~5250MHz Band Edge @ 3m	
ANT	802.11a CH48 5240MHz - R	
1+2	Vertical	
Peak	<p>Date: 2016.06.17</p> <p>Site : 03CH10-HY Condition : FCC CLASS-B 3m HORN 9120D-HF VERTICAL Detector : Peak Project : 652049 Mode : 3</p>	
Avg.	<p>Date: 2016.06.17</p> <p>Site : 03CH10-HY Condition : FCC CLASS-B (AVG) 3m HORN 9120D-HF VERTICAL Detector : Peak Project : 652049 Mode : 3</p>	



Band 1 5150~5250MHz

Band 1 - 5150~5250MHz

WIFI 802.11a (Harmonic @ 3m)

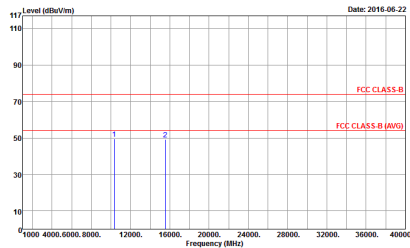
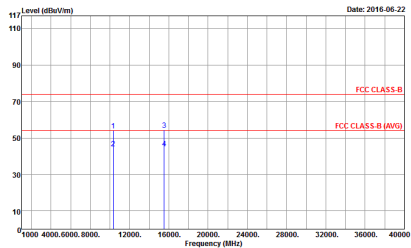
WIFI	Band 1 5150~5250MHz Harmonic @ 3m	
ANT	802.11a CH36 5180MHz	
1+2	Horizontal	Vertical
<p>Peak</p> <p>Avg.</p>	 <p>Site : 03CH10-HY Condition : FCC CLASS-B 3m HORN 9120D-HF HORIZONTAL Detector : Peak Project : 652049 Mode : 1</p>	 <p>Site : 03CH10-HY Condition : FCC CLASS-B 3m HORN 9120D-HF VERTICAL Detector : Peak Project : 652049 Mode : 1</p>

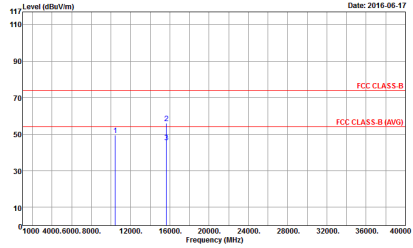
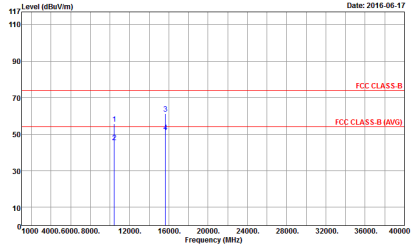

WIFI	Band 1 5150~5250MHz Harmonic @ 3m	
ANT	802.11a CH44 5220MHz	
1+2	Horizontal	Vertical
<p>Peak</p> <p>Avg.</p>	 <p>Site : 03CH10-HY Condition : FCC CLASS-B 3m HORN 9120D-HF HORIZONTAL Detector : Peak Project : 652049 Mode : 2</p>	 <p>Site : 03CH10-HY Condition : FCC CLASS-B 3m HORN 9120D-HF VERTICAL Detector : Peak Project : 652049 Mode : 2</p>

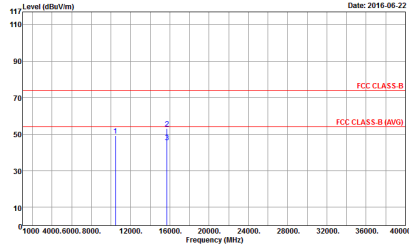
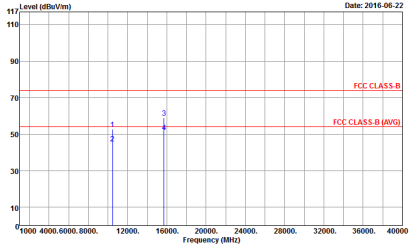

WIFI	Band 1 5150~5250MHz Harmonic @ 3m	
ANT	802.11a CH48 5240MHz	
1+2	Horizontal	Vertical
<p>Peak</p> <p>Avg.</p>	 <p>Site : 03CH10-HY Condition : FCC CLASS-B 3m HORN 9120D-HF HORIZONTAL Detector : Peak Project : 652049 Mode : 3</p>	 <p>Site : 03CH10-HY Condition : FCC CLASS-B 3m HORN 9120D-HF VERTICAL Detector : Peak Project : 652049 Mode : 3</p>



Band 1 5150~5250MHz

Emission below 1GHz

5GHz WIFI 802.11a (LF)

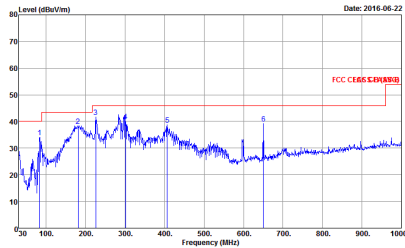
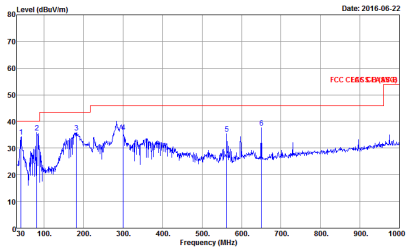
WIFI	5GHz WIFI	
ANT	802.11a LF	
1+2	Horizontal	Vertical
<p>QP / Peak</p>	 <p>Site : 03CH10-11Y Condition : FCC CLASS-B 3m BI-LOG 6111D-LF HORIZONTAL Detector : Peak Project : 652049 Mode : 10</p>	 <p>Site : 03CH10-11Y Condition : FCC CLASS-B 3m BI-LOG 6111D-LF VERTICAL Detector : Peak Project : 652049 Mode : 10</p>



<TXBF Modes>

Band 1 - 5150~5250MHz

WIFI 802.11ac VHT20 (Band Edge @ 3m)

WIFI	Band 1 5150~5250MHz Band Edge @ 3m	
ANT	802.11ac VHT20 CH36 5180MHz	
1	Horizontal	Fundamental
Peak	<p>Site : 03CH10-HY Condition : FCC CLASS-B 3m HORN 9120D-HF HORIZONTAL Detector : Peak Project : 652049 Mode : 4</p>	<p>Site : 03CH10-HY Condition : FCC CLASS-B 3m HORN 9120D-HF HORIZONTAL Detector : Peak Project : 652049 Mode : 4</p>
Avg.	<p>Site : 03CH10-HY Condition : FCC CLASS-B (AVG) 3m HORN 9120D-HF HORIZONTAL Detector : Peak Project : 652049 Mode : 4</p>	

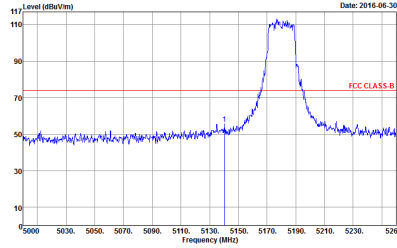
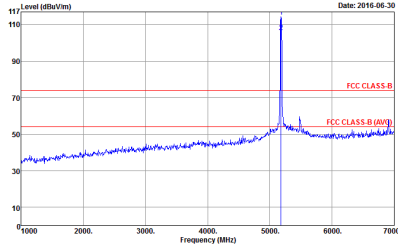
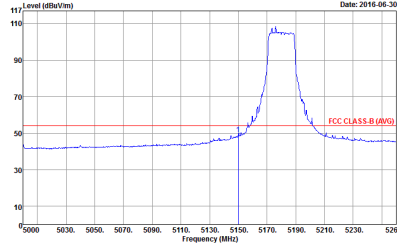

WIFI	Band 1 5150~5250MHz Band Edge @ 3m	
ANT	802.11ac VHT20 CH36 5180MHz	
1	Vertical	Fundamental
Peak	 <p>Date: 2016-06-30</p> <p>Site : 03CH10-HY Condition : FCC CLASS-B 3m HORN 9120D-HF VERTICAL RBW:1000.000KHz VBW:3000.000KHz SWT:Auto Detector : Peak Project : 652049 Mode : 4</p>	 <p>Date: 2016-06-30</p> <p>Site : 03CH10-HY Condition : FCC CLASS-B 3m HORN 9120D-HF VERTICAL RBW:1000.000KHz VBW:3000.000KHz SWT:Auto Detector : Peak Project : 652049 Mode : 4</p>
Avg.	 <p>Date: 2016-06-30</p> <p>Site : 03CH10-HY Condition : FCC CLASS-B (AVG) 3m HORN 9120D-HF VERTICAL RBW:1000.000KHz VBW:1.000KHz SWT:Auto Detector : Peak Project : 652049 Mode : 4</p>	

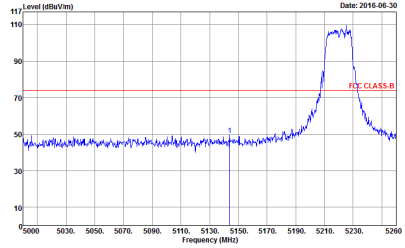
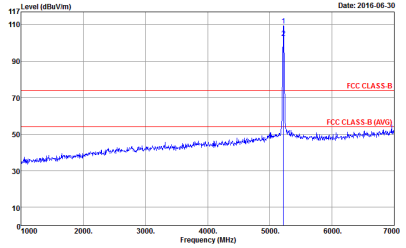
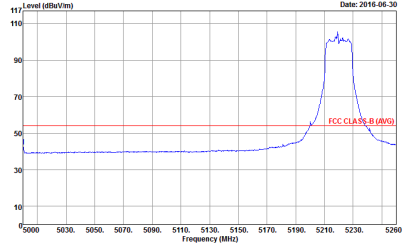

WIFI	Band 1 5150~5250MHz Band Edge @ 3m	
ANT	802.11ac VHT20 CH44 5220MHz - L	
1	Horizontal	Fundamental
Peak	 <p>Site : 03CH10-HY Condition : FCC CLASS-B 3m HORN 9120D-HF HORIZONTAL RBW:1000.000KHz VBW:3000.000KHz SWT:Auto Detector : Peak Project : 652049 Mode : 5</p>	 <p>Site : 03CH10-HY Condition : FCC CLASS-B 3m HORN 9120D-HF HORIZONTAL RBW:1000.000KHz VBW:3000.000KHz SWT:Auto Detector : Peak Project : 652049 Mode : 5</p>
Avg.	 <p>Site : 03CH10-HY Condition : FCC CLASS-B (AVG) 3m HORN 9120D-HF HORIZONTAL RBW:1000.000KHz VBW:1.000KHz SWT:Auto Detector : Peak Project : 652049 Mode : 5</p>	

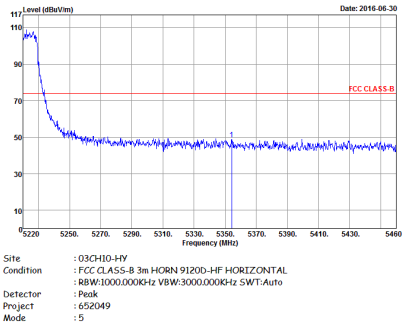
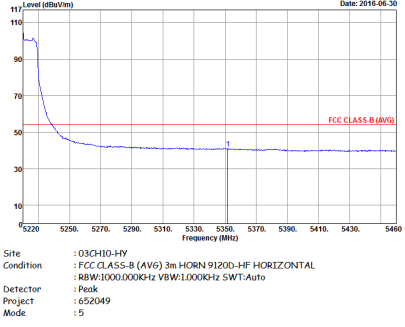

WIFI	Band 1 5150~5250MHz Band Edge @ 3m	
ANT	802.11ac VHT20 CH44 5220MHz - R	
1	Horizontal	
Peak	 <p>Site : 03CH10-HY Condition : FCC CLASS-B 3m HORN 9120D-HF HORIZONTAL Detector : Peak Project : 652049 Mode : 5</p>	
Avg.	 <p>Site : 03CH10-HY Condition : FCC CLASS-B (AVG) 3m HORN 9120D-HF HORIZONTAL Detector : Peak Project : 652049 Mode : 5</p>	

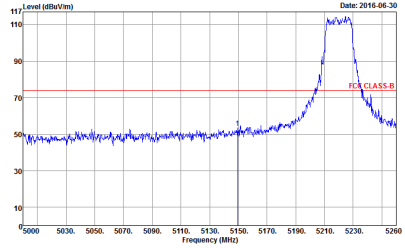
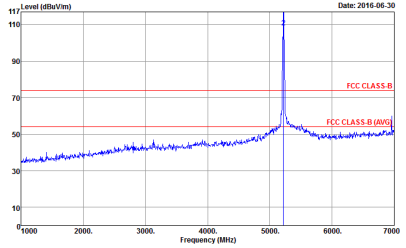
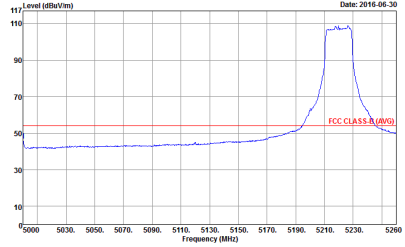

WIFI	Band 1 5150~5250MHz Band Edge @ 3m	
ANT	802.11ac VHT20 CH44 5220MHz - L	
1	Vertical	Fundamental
Peak	 <p>Date: 2016-06-30</p> <p>Site : 03CH10-HY Condition : FCC CLASS-B 3m HORN 9120D-HF VERTICAL RBW:1000.000KHz VBW:3000.000KHz SWT:Auto Detector : Peak Project : 652049 Mode : 5</p>	 <p>Date: 2016-06-30</p> <p>Site : 03CH10-HY Condition : FCC CLASS-B 3m HORN 9120D-HF VERTICAL RBW:1000.000KHz VBW:3000.000KHz SWT:Auto Detector : Peak Project : 652049 Mode : 5</p>
Avg.	 <p>Date: 2016-06-30</p> <p>Site : 03CH10-HY Condition : FCC CLASS-B (AVG) 3m HORN 9120D-HF VERTICAL RBW:1000.000KHz VBW:1.000KHz SWT:Auto Detector : Peak Project : 652049 Mode : 5</p>	

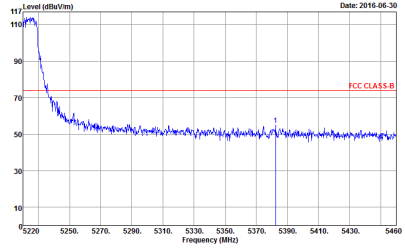
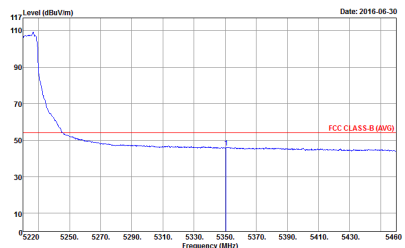

WIFI	Band 1 5150~5250MHz Band Edge @ 3m	
ANT	802.11ac VHT20 CH44 5220MHz - R	
1	Vertical	
Peak	 <p> Site : 03CH10-HY Condition : FCC CLASS-B 3m HORN 9120D-HF VERTICAL RBW:1000.000KHz VBW:3000.000KHz SWT:Auto Detector : Peak Project : 652049 Mode : 5 </p>	
Avg.	 <p> Site : 03CH10-HY Condition : FCC CLASS-B (AVG) 3m HORN 9120D-HF VERTICAL RBW:1000.000KHz VBW:1.000KHz SWT:Auto Detector : Peak Project : 652049 Mode : 5 </p>	



WIFI	Band 1 5150~5250MHz Band Edge @ 3m	
ANT	802.11ac VHT20 CH48 5240MHz - L	
1	Horizontal	Fundamental
Peak	<p>Site : 03CH10-HY Condition : FCC CLASS-B 3m HORN 9120D-HF HORIZONTAL RBW:1000.000KHz VBW:3000.000KHz SWT:Auto Detector : Peak Project : 652049 Mode : 6</p>	<p>Site : 03CH10-HY Condition : FCC CLASS-B 3m HORN 9120D-HF HORIZONTAL RBW:1000.000KHz VBW:3000.000KHz SWT:Auto Detector : Peak Project : 652049 Mode : 6</p>
Avg.	<p>Site : 03CH10-HY Condition : FCC CLASS-B (AVG) 3m HORN 9120D-HF HORIZONTAL RBW:1000.000KHz VBW:1.000KHz SWT:Auto Detector : Peak Project : 652049 Mode : 6</p>	

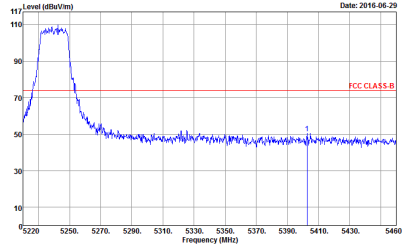
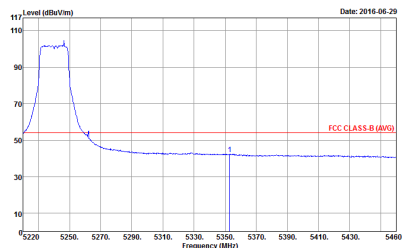

WIFI	Band 1 5150~5250MHz Band Edge @ 3m	
ANT	802.11ac VHT20 CH48 5240MHz - R	
1	Horizontal	
Peak	 <p> Site : 03CH10-HY Condition : FCC CLASS-B 3m HORN 9120D-HF HORIZONTAL Detector : Peak Project : 652049 Mode : 6 </p>	
Avg.	 <p> Site : 03CH10-HY Condition : FCC CLASS-B (AVG) 3m HORN 9120D-HF HORIZONTAL Detector : Peak Project : 652049 Mode : 6 </p>	

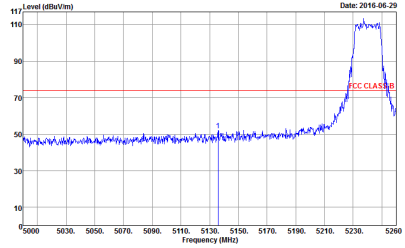
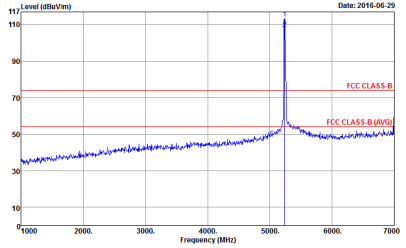
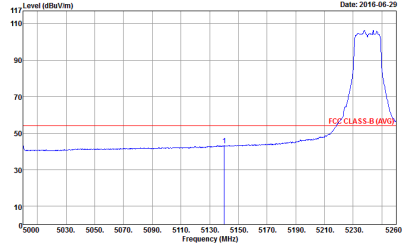

WIFI	Band 1 5150~5250MHz Band Edge @ 3m	
ANT	802.11ac VHT20 CH48 5240MHz - L	
1	Vertical	Fundamental
Peak	 <p>Site : 03CH10-HY Condition : FCC CLASS-B 3m HORN 91200-HF VERTICAL RBW:1000.000KHz VBW:3000.000KHz SWT:Auto Detector : Peak Project : 652049 Mode : 6</p>	 <p>Site : 03CH10-HY Condition : FCC CLASS-B 3m HORN 91200-HF VERTICAL RBW:1000.000KHz VBW:3000.000KHz SWT:Auto Detector : Peak Project : 652049 Mode : 6</p>
Avg.	 <p>Site : 03CH10-HY Condition : FCC CLASS-B (AVG) 3m HORN 91200-HF VERTICAL RBW:1000.000KHz VBW:1.000KHz SWT:Auto Detector : Peak Project : 652049 Mode : 6</p>	

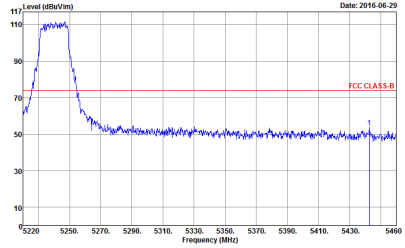
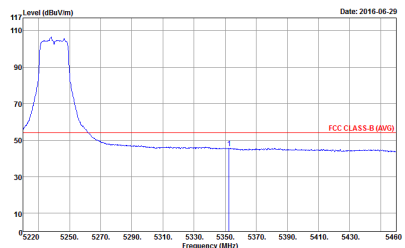

WIFI	Band 1 5150~5250MHz Band Edge @ 3m	
ANT	802.11ac VHT20 CH48 5240MHz - R	
1	Vertical	
Peak	 <p>Date: 2016-06-29</p> <p>Site : 03CH10-HY Condition : FCC CLASS-B 3m HORN 9120D-HF VERTICAL RBW:1000.000KHz VBW:3000.000KHz SWT:Auto Detector : Peak Project : 652049 Mode : 6</p>	
Avg.	 <p>Date: 2016-06-29</p> <p>Site : 03CH10-HY Condition : FCC CLASS-B (AVG) 3m HORN 9120D-HF VERTICAL RBW:1000.000KHz VBW:1.000KHz SWT:Auto Detector : Peak Project : 652049 Mode : 6</p>	

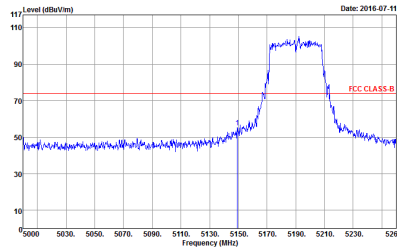
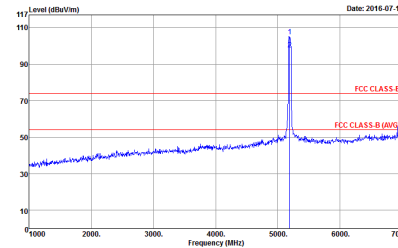
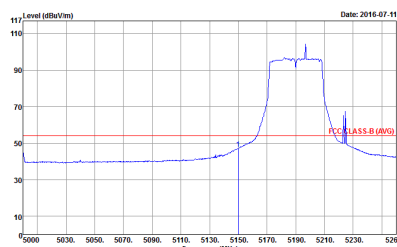

Band 1 5150~5250MHz
WIFI 802.11ac VHT40 (Band Edge @ 3m)

WIFI	Band 1 5150~5250MHz Band Edge @ 3m	
ANT	802.11ac VHT40 CH38 5190MHz - L	
1	Horizontal	Fundamental
Peak	 <p>Site : 03CH10-HY Condition : FCC CLASS-B 3m HORN 9120D-HF HORIZONTAL Detector : Peak Project : 652049 Mode : 7</p>	 <p>Site : 03CH10-HY Condition : FCC CLASS-B 3m HORN 9120D-HF HORIZONTAL Detector : Peak Project : 652049 Mode : 7</p>
Avg.	 <p>Site : 03CH10-HY Condition : FCC CLASS-B (AVG) 3m HORN 9120D-HF HORIZONTAL Detector : Peak Project : 652049 Mode : 7</p>	

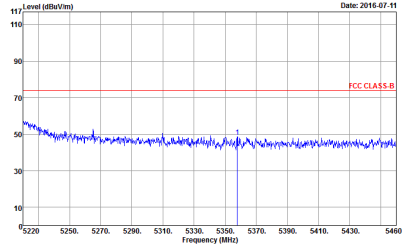
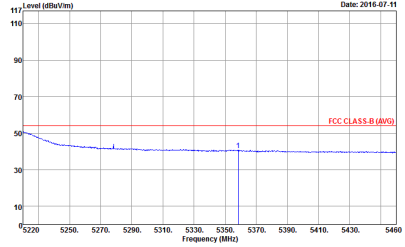

WIFI	Band 1 5150~5250MHz Band Edge @ 3m	
ANT	802.11ac VHT40 CH38 5190MHz - R	
1	Horizontal	
Peak	 <p> Site : 03CH10-HY Condition : FCC CLASS-B 3m HORN 9120D-HF HORIZONTAL RBW:1000.000KHz VBW:3000.000KHz SWT:Auto Detector : Peak Project : 652049 Mode : 7 </p>	
Avg.	 <p> Site : 03CH10-HY Condition : FCC CLASS-B (AVG) 3m HORN 9120D-HF HORIZONTAL RBW:1000.000KHz VBW:1.000KHz SWT:Auto Detector : Peak Project : 652049 Mode : 7 </p>	

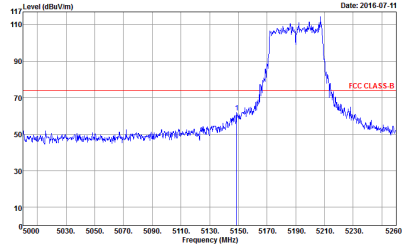
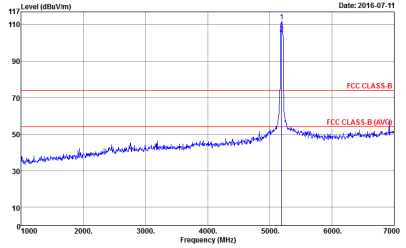
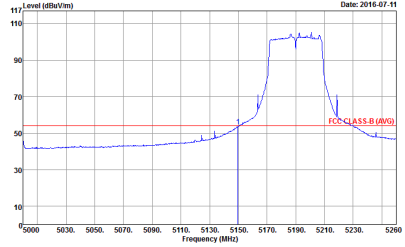

WIFI	Band 1 5150~5250MHz Band Edge @ 3m	
ANT	802.11ac VHT40 CH38 5190MHz - L	
1	Vertical	Fundamental
Peak	 <p>Site : 03CH10-HY Condition : FCC CLASS-B 3m HORN 9120D-HF VERTICAL RBW:1000.000KHz VBW:3000.000KHz SWT:Auto Detector : Peak Project : 652049 Mode : 7</p>	 <p>Site : 03CH10-HY Condition : FCC CLASS-B 3m HORN 9120D-HF VERTICAL RBW:1000.000KHz VBW:3000.000KHz SWT:Auto Detector : Peak Project : 652049 Mode : 7</p>
Avg.	 <p>Site : 03CH10-HY Condition : FCC CLASS-B (AVG) 3m HORN 9120D-HF VERTICAL RBW:1000.000KHz VBW:1.000KHz SWT:Auto Detector : Peak Project : 652049 Mode : 7</p>	

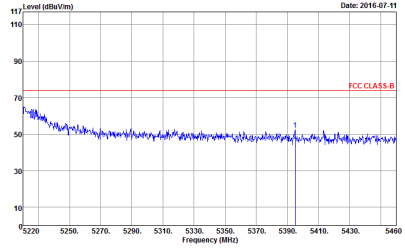
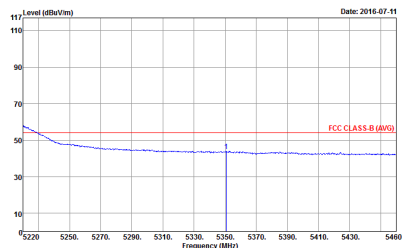

WIFI	Band 1 5150~5250MHz Band Edge @ 3m	
ANT	802.11ac VHT40 CH38 5190MHz - R	
1	Vertical	
Peak	 <p>Site : 03CH10-HY Condition : FCC CLASS-B 3m HORN 9120D-HF VERTICAL RBW:1000.000KHz VBW:3000.000KHz SWT:Auto Detector : Peak Project : 652049 Mode : 7</p>	
Avg.	 <p>Site : 03CH10-HY Condition : FCC CLASS-B (AVG) 3m HORN 9120D-HF VERTICAL RBW:1000.000KHz VBW:1.000KHz SWT:Auto Detector : Peak Project : 652049 Mode : 7</p>	

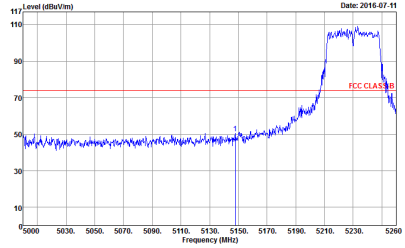
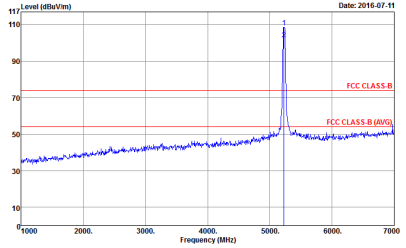
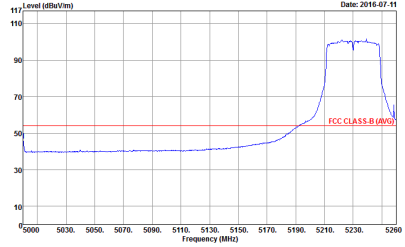

WIFI	Band 1 5150~5250MHz Band Edge @ 3m	
ANT	802.11ac VHT40 CH46 5230MHz - L	
1	Horizontal	Fundamental
Peak	 <p>Date: 2016-07-11</p> <p>Site : 03CH10-HY Condition : FCC CLASS-B 3m HORN 9120D-HF HORIZONTAL RBW:1000.000KHz VBW:3000.000KHz SWT:Auto Detector : Peak Project : 652049 Mode : B</p>	 <p>Date: 2016-07-11</p> <p>Site : 03CH10-HY Condition : FCC CLASS-B 3m HORN 9120D-HF HORIZONTAL RBW:1000.000KHz VBW:3000.000KHz SWT:Auto Detector : Peak Project : 652049 Mode : B</p>
Avg.	 <p>Date: 2016-07-11</p> <p>Site : 03CH10-HY Condition : FCC CLASS-B (AVG) 3m HORN 9120D-HF HORIZONTAL RBW:1000.000KHz VBW:1.000KHz SWT:Auto Detector : Peak Project : 652049 Mode : B</p>	

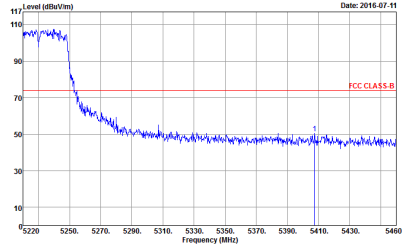
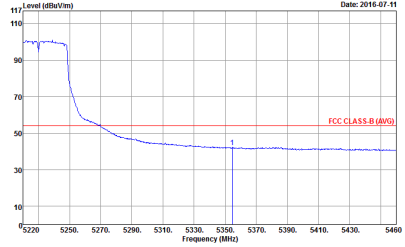

WIFI	Band 1 5150~5250MHz Band Edge @ 3m	
ANT	802.11ac VHT40 CH46 5230MHz - R	
1	Horizontal	
Peak	 <p style="font-size: small;">Date: 2016-07-11</p> <p>Site : 03CH10-HY Condition : FCC CLASS-B 3m HORN 9120D-HF HORIZONTAL RBW:1000.000KHz VBW:3000.000KHz SWT:Auto Detector : Peak Project : 652049 Mode : B</p>	
Avg.	 <p style="font-size: small;">Date: 2016-07-11</p> <p>Site : 03CH10-HY Condition : FCC CLASS-B (AVG) 3m HORN 9120D-HF HORIZONTAL RBW:1000.000KHz VBW:1.000KHz SWT:Auto Detector : Peak Project : 652049 Mode : B</p>	

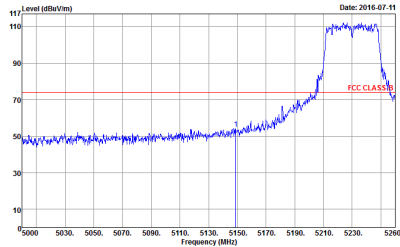
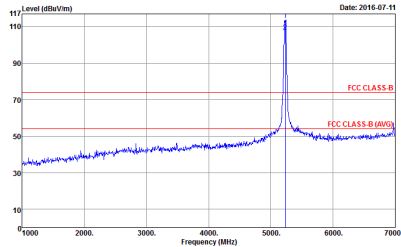
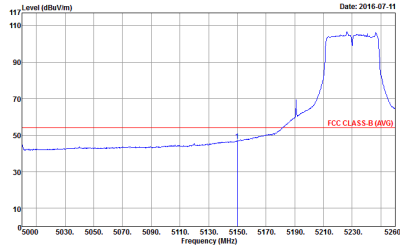

WIFI	Band 1 5150~5250MHz Band Edge @ 3m	
ANT	802.11ac VHT40 CH46 5230MHz - L	
1	Vertical	Fundamental
Peak	 <p>Date: 2016-07-11</p> <p>Site : 03CH10-HY Condition : FCC CLASS-B 3m HORN 9120D-HF VERTICAL RBW:1000.000KHz VBW:3000.000KHz SWT:Auto Detector : Peak Project : 652049 Mode : B</p>	 <p>Date: 2016-07-11</p> <p>Site : 03CH10-HY Condition : FCC CLASS-B 3m HORN 9120D-HF VERTICAL RBW:1000.000KHz VBW:3000.000KHz SWT:Auto Detector : Peak Project : 652049 Mode : B</p>
Avg.	 <p>Date: 2016-07-11</p> <p>Site : 03CH10-HY Condition : FCC CLASS-B (AVG) 3m HORN 9120D-HF VERTICAL RBW:1000.000KHz VBW:1.000KHz SWT:Auto Detector : Peak Project : 652049 Mode : B</p>	

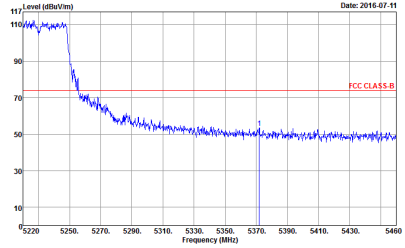
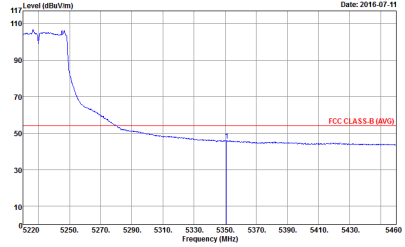

WIFI	Band 1 5150~5250MHz Band Edge @ 3m	
ANT	802.11ac VHT40 CH46 5230MHz - R	
1	Vertical	
Peak	 <p>Date: 2016-07-11</p> <p>Site : 03CH10-HY Condition : FCC CLASS-B 3m HORN 9120D-HF VERTICAL RBW:1000.000KHz VBW:3000.000KHz SWT:Auto Detector : Peak Project : 652049 Mode : B</p>	
Avg.	 <p>Date: 2016-07-11</p> <p>Site : 03CH10-HY Condition : FCC CLASS-B (AVG) 3m HORN 9120D-HF VERTICAL RBW:1000.000KHz VBW:1.000KHz SWT:Auto Detector : Peak Project : 652049 Mode : B</p>	

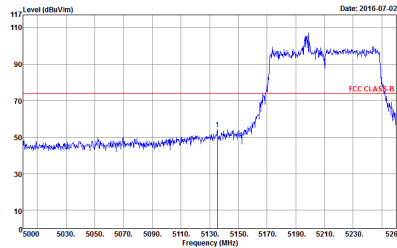
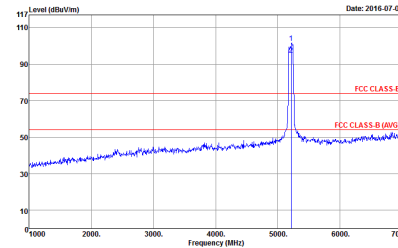
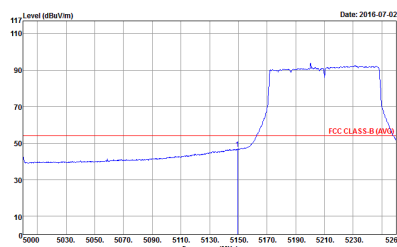

**Band 1 5150~5250MHz
WIFI 802.11ac VHT80 (Band Edge @ 3m)**

WIFI	Band 1 5150~5250MHz Band Edge @ 3m	
ANT	802.11ac VHT80 CH42 5210MHz - L	
1	Horizontal	Fundamental
Peak	 <p>Site : 03CH10-HY Condition : FCC CLASS-B 3m HORN 9120D-HF HORIZONTAL Detector : Peak Project : 652049 Mode : 9</p>	 <p>Site : 03CH10-HY Condition : FCC CLASS-B 3m HORN 9120D-HF HORIZONTAL Detector : Peak Project : 652049 Mode : 9</p>
Avg.	 <p>Site : 03CH10-HY Condition : FCC CLASS-B (AVG) 3m HORN 9120D-HF HORIZONTAL Detector : Peak Project : 652049 Mode : 9</p>	

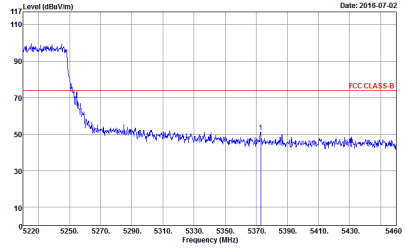
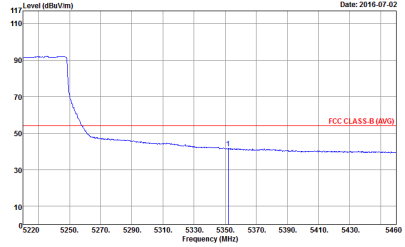

WIFI	Band 1 5150~5250MHz Band Edge @ 3m	
ANT	802.11ac VHT80 CH42 5210MHz - R	
1	Horizontal	
Peak	 <p>Date: 2016-07-02</p> <p>Site : 03CH10-HY Condition : FCC CLASS-B 3m HORN 9120D-HF HORIZONTAL RBW:1000.000KHz VBW:3000.000KHz SWT:Auto Detector : Peak Project : 652049 Mode : 9</p>	
Avg.	 <p>Date: 2016-07-02</p> <p>Site : 03CH10-HY Condition : FCC CLASS-B (AVG) 3m HORN 9120D-HF HORIZONTAL RBW:1000.000KHz VBW:3.000KHz SWT:Auto Detector : Peak Project : 652049 Mode : 9</p>	

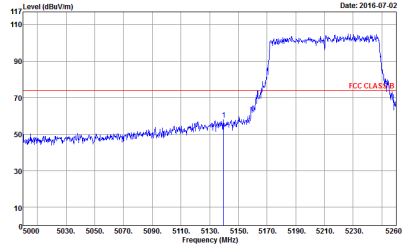
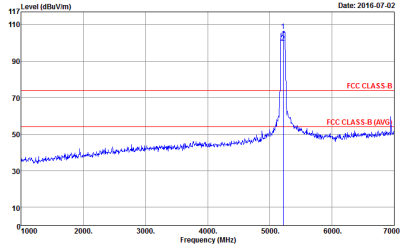
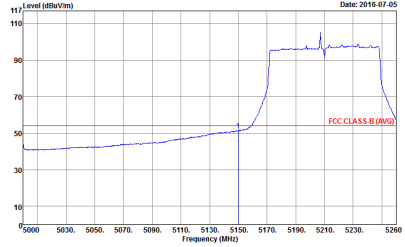

WIFI	Band 1 5150~5250MHz Band Edge @ 3m	
ANT	802.11ac VHT80 CH42 5210MHz - L	
1	Vertical	Fundamental
Peak	 <p>Site : 03CH10-HY Condition : FCC CLASS-B 3m HORN 9120D-HF VERTICAL RBW:1000.000KHz VBW:3000.000KHz SWT:Auto Detector : Peak Project : 652049 Mode : 9</p>	 <p>Site : 03CH10-HY Condition : FCC CLASS-B 3m HORN 9120D-HF VERTICAL RBW:1000.000KHz VBW:3000.000KHz SWT:Auto Detector : Peak Project : 652049 Mode : 9</p>
Avg.	 <p>Site : 03CH10-HY Condition : FCC CLASS-B (AVG) 3m HORN 9120D-HF VERTICAL RBW:1000.000KHz VBW:3.000KHz SWT:Auto Detector : Peak Project : 652049 Mode : 9</p>	

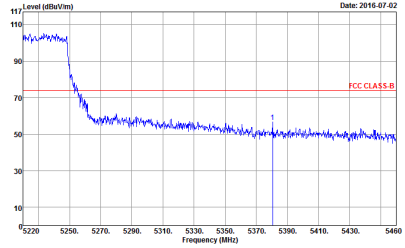
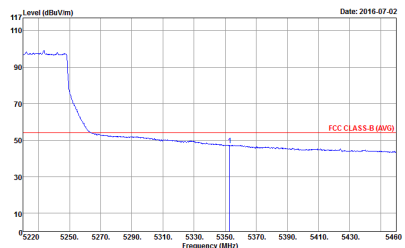

WIFI	Band 1 5150~5250MHz Band Edge @ 3m	
ANT	802.11ac VHT80 CH42 5210MHz - R	
1	Vertical	
Peak	 <p>Date: 2016-07-02</p> <p>Site : 03CH10-HY Condition : FCC CLASS-B 3m HORN 9120D-HF VERTICAL RBW:1000.000KHz VBW:3000.000KHz SWT:Auto Detector : Peak Project : 652049 Mode : 9</p>	
Avg.	 <p>Date: 2016-07-02</p> <p>Site : 03CH10-HY Condition : FCC CLASS-B (AVG) 3m HORN 9120D-HF VERTICAL RBW:1000.000KHz VBW:3.000KHz SWT:Auto Detector : Peak Project : 652049 Mode : 9</p>	

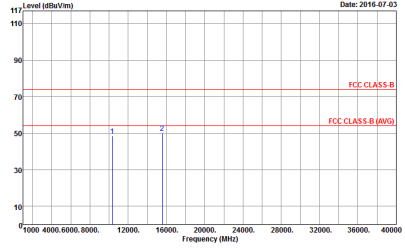
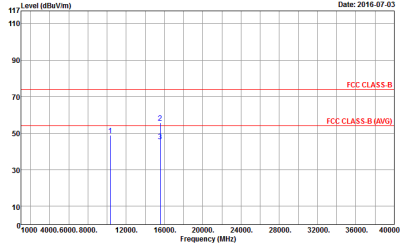

Band 1 - 5150~5250MHz
WIFI 802.11ac VHT20 (Harmonic @ 3m)

WIFI	Band 1 5150~5250MHz Harmonic @ 3m	
ANT	802.11ac VHT20 CH36 5180MHz	
1	Horizontal	Vertical
Peak Avg.	 <p>Date: 2016-07-03</p> <p>Site : 03CH10-HY Condition : FCC CLASS-B 3m HORN 9120D-HF HORIZONTAL Detector : Peak Project : 652049 Mode : 4</p>	 <p>Date: 2016-07-03</p> <p>Site : 03CH10-HY Condition : FCC CLASS-B 3m HORN 9120D-HF VERTICAL Detector : Peak Project : 652049 Mode : 4</p>

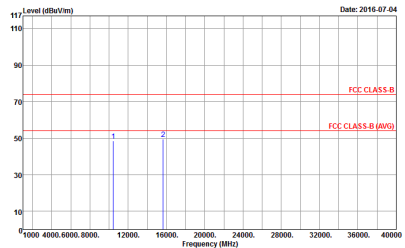
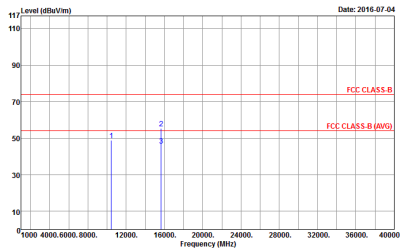

WIFI	Band 1 5150~5250MHz Harmonic @ 3m	
ANT	802.11ac VHT20 CH44 5220MHz	
1	Horizontal	Vertical
<p>Peak</p> <p>Avg.</p>	 <p>Site : 03CH10-HY Condition : FCC CLASS-B 3m HORN 9120D-HF HORIZONTAL Detector : Peak Project : 652049 Mode : S</p>	 <p>Site : 03CH10-HY Condition : FCC CLASS-B 3m HORN 9120D-HF VERTICAL Detector : Peak Project : 652049 Mode : S</p>

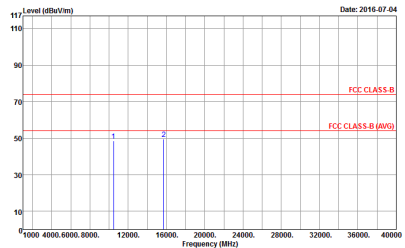
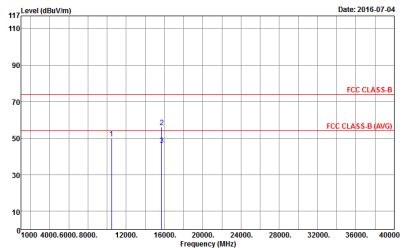

WIFI	Band 1 5150~5250MHz Harmonic @ 3m	
ANT	802.11ac VHT20 CH48 5240MHz	
1	Horizontal	Vertical
<p>Peak</p> <p>Avg.</p>	 <p>Site : 03CH10-HY Condition : FCC CLASS-B 3m HORN 9120D-HF HORIZONTAL Detector : Peak Project : 652049 Mode : 6</p>	 <p>Site : 03CH10-HY Condition : FCC CLASS-B 3m HORN 9120D-HF VERTICAL Detector : Peak Project : 652049 Mode : 6</p>



Band 1 5150~5250MHz
WIFI 802.11ac VHT40 (Harmonic @ 3m)

Table with 2 columns: Horizontal and Vertical. Each column contains a spectral plot showing Level (dBuV/m) vs Frequency (MHz) with FCC CLASS-B and FCC CLASS-B (AVG) limits. Includes site and condition details for both orientations.

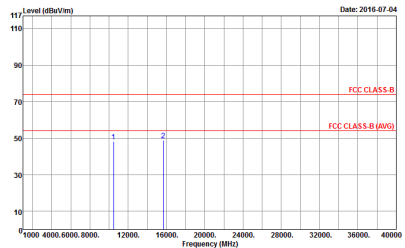
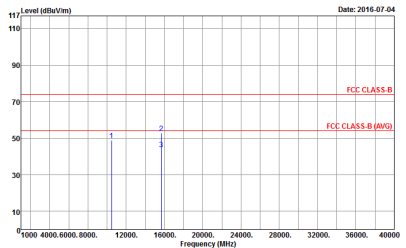

WIFI	Band 1 5150~5250MHz Harmonic @ 3m	
ANT	802.11ac VHT40 CH46 5230MHz	
1	Horizontal	Vertical
Peak Avg.	 <p>Site : 03CH10-HY Condition : FCC CLASS-B 3m HORN 9120D-HF HORIZONTAL Detector : Peak Project : 652049 Mode : B</p>	 <p>Site : 03CH10-HY Condition : FCC CLASS-B 3m HORN 9120D-HF VERTICAL Detector : Peak Project : 652049 Mode : B</p>



Band 1 5150~5250MHz
WIFI 802.11ac VHT80 (Harmonic @ 3m)

Table with 2 columns: Horizontal and Vertical. Each column contains a spectral plot showing Level (dBuV/m) vs Frequency (MHz) with FCC CLASS-B and FCC CLASS-B (AVG) limits. Includes metadata like Site, Condition, and Project.



**Emission below 1GHz
5GHz WIFI 802.11ac VHT20 (LF)**

WIFI	5GHz WIFI	
ANT	802.11ac VHT20 LF	
1	Horizontal	Vertical
QP / Peak	<p> Site : 03CH10-HY Condition : FCC CLASS-B 3m BI-LOG 6111D-LF HORIZONTAL Detector : Peak Project : 652049 Mode : 11 </p>	<p> Site : 03CH10-HY Condition : FCC CLASS-B 3m BI-LOG 6111D-LF VERTICAL Detector : Peak Project : 652049 Mode : 11 </p>



Emission below 1GHz
5GHz WIFI 802.11ac VHT40 (LF)

Table with 2 columns: WIFI (5GHz WIFI) and ANT (802.11ac VHT40 LF). It contains two sub-tables for 'Horizontal' and 'Vertical' orientations, each with a spectral plot and associated test parameters like Site, Condition, Detector, Project, and Mode.



**Emission below 1GHz
5GHz WIFI 802.11ac VHT80 (LF)**

WIFI	5GHz WIFI	
ANT	802.11ac VHT80 LF	
1	Horizontal	Vertical
QP / Peak	<p>Site : 03CH10-HY Condition : FCC CLASS-B 3m BI-LOG 6111D-LF HORIZONTAL Detector : Peak Project : 652049 Mode : 9</p>	<p>Site : 03CH10-HY Condition : FCC CLASS-B 3m BI-LOG 6111D-LF VERTICAL Detector : Peak Project : 652049 Mode : 9</p>

Note: The quasi peak value can pass the limit line as listed in Appendix B.



Appendix D. Duty Cycle Plots

<CDD Modes>

Antenna		Duty Cycle(%)	T(us)	1/T(kHz)	VBW Setting
1+2+3+4	802.11a ANT 1	96.27	2064	0.484	1kHz
1+2+3+4	802.11a ANT 2	96.27	2064	0.484	1kHz
1+2+3+4	802.11a ANT 3	96.27	2064	0.484	1kHz
1+2+3+4	802.11a ANT 4	96.24	2048	0.488	1kHz



802.11a

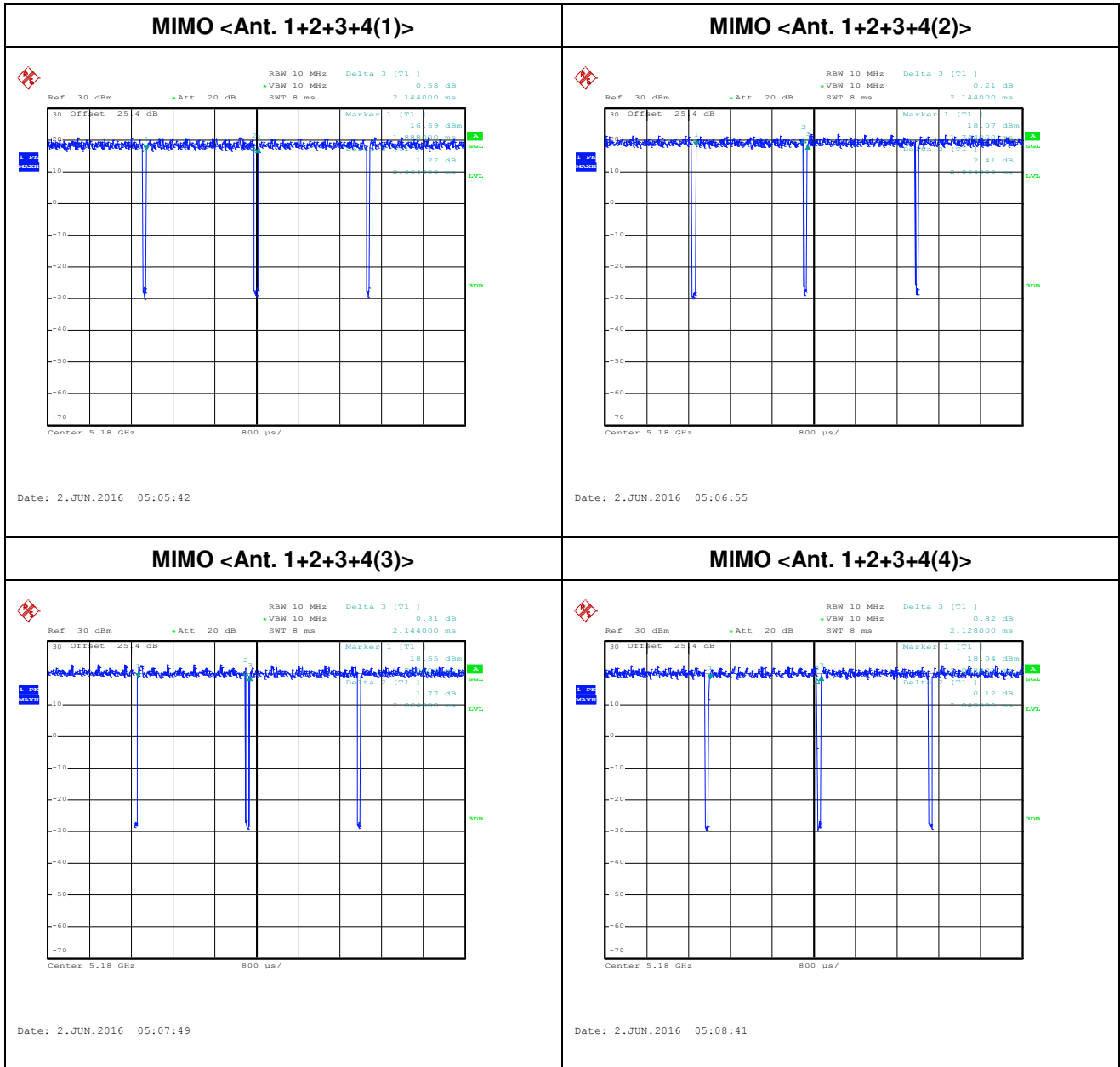

<TXBF Modes>

Antenna		Duty Cycle(%)	T(us)	1/T(kHz)	VBW Setting
1+2+3+4	802.11ac VHT20 ANT 1	98.58*	5016	0.194	1kHz
1+2+3+4	802.11ac VHT20 ANT 2	98.58*	5016	0.194	1kHz
1+2+3+4	802.11ac VHT20 ANT 3	98.58*	5016	0.194	1kHz
1+2+3+4	802.11ac VHT20 ANT 4	98.58*	5016	0.194	1kHz

Antenna		Duty Cycle(%)	T(us)	1/T(kHz)	VBW Setting
1+2+3+4	802.11ac VHT40 ANT 1	96.82*	2432	0.411	1kHz
1+2+3+4	802.11ac VHT40 ANT 2	97.45*	2448	0.408	1kHz
1+2+3+4	802.11ac VHT40 ANT 3	96.82*	2432	0.411	1kHz
1+2+3+4	802.11ac VHT40 ANT 4	97.45*	2448	0.408	1kHz

Antenna		Duty Cycle(%)	T(us)	1/T(kHz)	VBW Setting
1+2+3+4	802.11ac VHT80 ANT 1	94.31*	1160	0.862	1kHz
1+2+3+4	802.11ac VHT80 ANT 2	93.44*	1140	0.877	1kHz
1+2+3+4	802.11ac VHT80 ANT 3	93.50*	1150	0.869	1kHz
1+2+3+4	802.11ac VHT80 ANT 4	92.74*	1150	0.869	1kHz

Note *: Duty cycle is not a constant value during the continuous beamforming transmission.



802.11ac VHT20

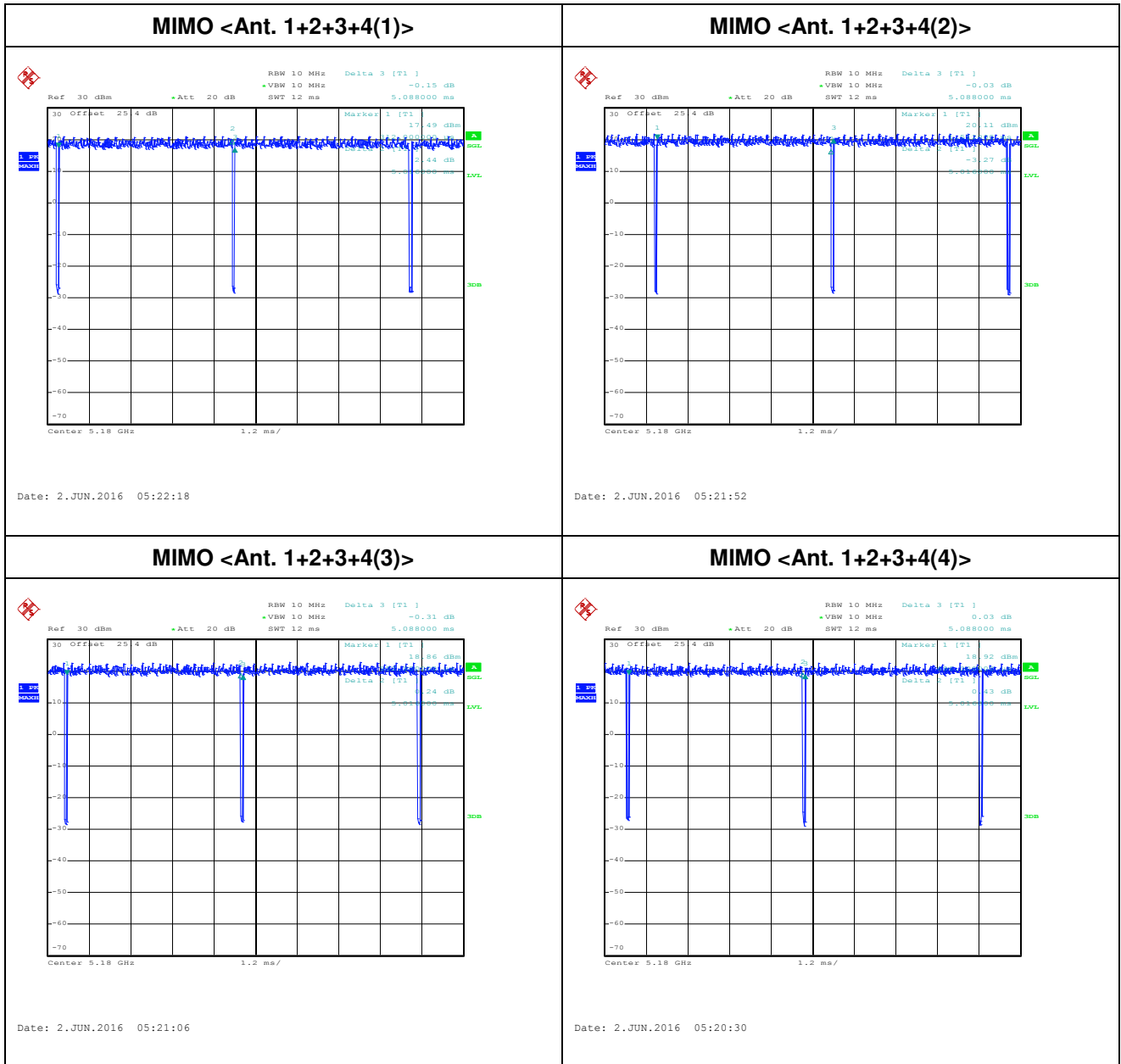



802.11ac VHT40

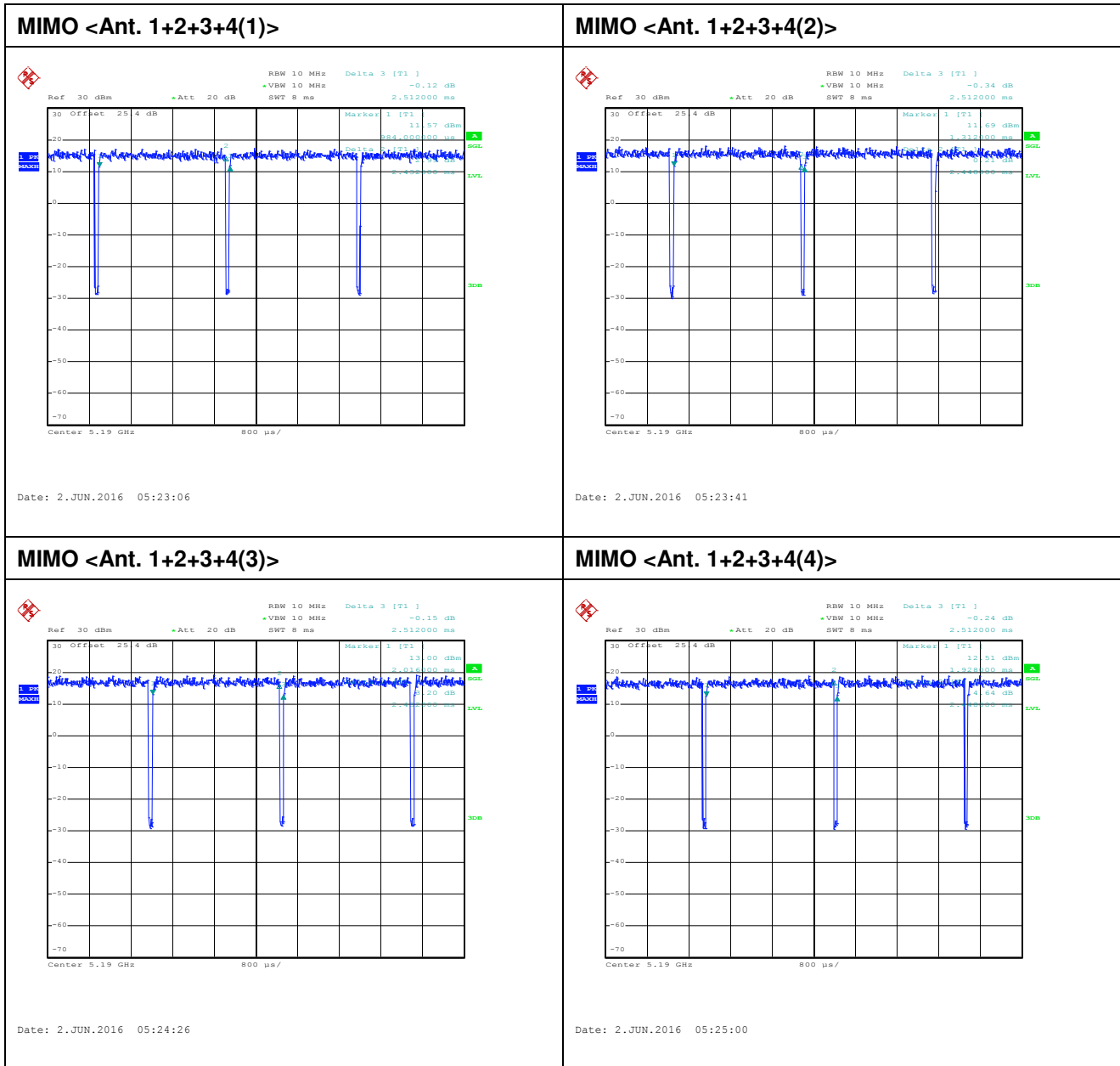



802.11ac VHT80

