



FCC TEST REPORT

For

M&S Accessory Network

Solar Magsafe Power Bank 5000mAh

Test Model: BK14-5MSL-BK

Additional Model No.: BK14-5MSL-OR, LC19

Prepared for : M&S Accessory Network
Address : 10 West 33rd Street. New York NY. 10001

Prepared by : Shenzhen LCS Compliance Testing Laboratory Ltd.
Address : 101, 201 Bldg A & 301 Bldg C, Juji Industrial Park Shajing Street,
Baoan District, Shenzhen, China
Tel : (+86)755-82591330
Fax : (+86)755-82591332
Web : www.LCS-cert.com
Mail : webmaster@LCS-cert.com

Date of receipt of test sample : April 17, 2024
Number of tested samples : 2
Sample No. : A240416052-1(Engineer sample), A240416052-2(Normal sample)
Date of Test : April 17, 2024 ~ May 06, 2024
Date of Report : May 07, 2024





FCC TEST REPORT
KDB 680106 D01 Wireless Power Transfer v04

Report Reference No. : LCSEA04164064EB

Date of Issue : May 07, 2024

Testing Laboratory Name : Shenzhen LCS Compliance Testing Laboratory Ltd.

Address : 101, 201 Bldg A & 301 Bldg C, Juji Industrial Park Shajing Street, Baoan District, Shenzhen, China

Testing Location/ Procedure : Full application of Harmonised standards
Partial application of Harmonised standards
Other standard testing method

Applicant's Name : M&S Accessory Network

Address : 10 West 33rd Street. New York NY. 10001

Test Specification

Standard : FCC CFR 47 PART 1, § 1.1310
KDB 680106 D01 Wireless Power Transfer v04

Test Report Form No. : LCSEMC-1.0

TRF Originator : Shenzhen LCS Compliance Testing Laboratory Ltd.

Master TRF : Dated 2023-12

Shenzhen LCS Compliance Testing Laboratory Ltd. All rights reserved.

This publication may be reproduced in whole or in part for non-commercial purposes as long as the Shenzhen LCS Compliance Testing Laboratory Ltd. is acknowledged as copyright owner and source of the material.

EUT Description. : Solar Magsafe Power Bank 5000mAh

Trade Mark : Brookstone

Test Model : BK14-5MSL-BK

Ratings : Micro/Type-C Input: DC 5V/2A, DC 9V/2A, DC 12V/1.5A-PD18W Max
Type-C Output: DC 5V/3A, DC 9V/2.22A, DC 12V/1.5A-PD20W Max
USB-A Ouput: DC 5V/3A, DC 9V/2A, DC 12V/1.5A, DC 5V/4.5A, DC 4.5V/5A-PD22.5W Max

Result : Positive

Compiled by:

Handwritten signature of Jack Liu

Jack Liu/ Administrator

Supervised by:

Handwritten signature of Cary Luo

Cary Luo/ Technique principal

Approved by:

Handwritten signature of Gavin Liang

Gavin Liang/ Manager





ISED -- TEST REPORT

Test Report No. : LCSA04164064EB	<u>May 07, 2024</u> Date of issue
---	--------------------------------------

Test Model.....	: BK14-5MSL-BK
EUT.....	: Solar Magsafe Power Bank 5000mAh
Applicant.....	: M&S Accessory Network
Address.....	: 10 West 33rd Street. New York NY. 10001
Telephone.....	:
Fax.....	:
Manufacturer.....	: Shenzhen Ruilanxin Technology Co., Ltd
Address.....	: A403,Block B, Huada Industry, Fuqiao Industrial Area No.3 , Fuhai, Bao'an district, 518103 Shenzhen
Telephone.....	:
Fax.....	:
Factory.....	: Shenzhen Ruilanxin Technology Co., Ltd
Address.....	: A403,Block B, Huada Industry, Fuqiao Industrial Area No.3 , Fuhai, Bao'an district, 518103 Shenzhen
Telephone.....	:
Fax.....	:

Test Result	Positive
--------------------	-----------------

The test report merely corresponds to the test sample.

It is not permitted to copy extracts of these test result without the written permission of the test laboratory.





Revision History

Revision	Issue Date	Revisions	Revised By
000	May 07, 2024	Initial Issue	--





TABLE OF CONTENTS

1. GENERAL INFORMATION 6

1.1. DESCRIPTION OF DEVICE (EUT) 6

1.2. SUPPORT EQUIPMENT LIST 7

1.3. EXTERNAL I/O CABLE 7

1.4. DESCRIPTION OF TEST FACILITY 7

1.5. TEST EQUIPMENT 7

1.6. MEASUREMENT UNCERTAINTY 7

1.7. DESCRIPTION OF TEST MODES 8

1.8. COIL DESCRIPTION 8

1.9. COIL SIZE 8

1.10. COIL SPECIFICATIONS 9

1.11. DUTY CYCLE 9

2. TEST METHODOLOGY 10

2.1. REFERENCE EVALUATION METHOD 10

2.2. LIMIT 10

2.3. TEST SETUP DIAGRAM 10

2.4. MEASUREMENT PROCEDURE 11

2.5. EQUIPMENT APPROVAL CONSIDERATIONS OF KDB 680106 D01V04 12

3. TEST RESULTS 13

3.1 VALIDATION RESULTS FOR THE NUMERICAL CALCULATION MODEL 14

3.2 FINAL H-FIELD EMISSION LEVEL WITH A COMBINATION OF MEASURED AND ESTIMATED RESULTS. 14

3.3 CONCLUSION 14

4. TEST SETUP PHOTOS 15





1. GENERAL INFORMATION

1.1. Description of Device (EUT)

EUT : Solar Magsafe Power Bank 5000mAh

Test Model : BK14-5MSL-BK

Additional Model No. : BK14-5MSL-OR, LC19

Model Declaration : PCB board, structure and internal of these model(s) are the same, So no additional models were tested

Power Supply : Micro/Type-C Input: DC 5V/2A, DC 9V/2A, DC 12V/1.5A-PD18W Max
Type-C Output: DC 5V/3A, DC 9V/2.22A, DC 12V/1.5A-PD20W Max
USB-A Output: DC 5V/3A, DC 9V/2A, DC 12V/1.5A, DC 5V/4.5A, DC 4.5V/5A-PD22.5W Max

Hardware Version : V1.0

Software Version : V1.0

Wireless Charging :

Operating Frequency : 110.1~205.0KHz

Modulation Type : ASK

Antenna Type : Coil Antenna





1.2. Support equipment List

Manufacturer	Description	Model	Serial Number	Certificate
HONOR	Phone	V30Pro	---	FCC
SHENZHEN TIANYIN ELECTRONICS CO., LTD	Power Adapter	TPA-46050200UU	---	FCC

Note: Auxiliary equipment is provided by the laboratory.

1.3. External I/O Cable

I/O Port Description	Quantity	Cable
USB Port	1	USB Cable: 0.3m, unshielded
Micro USB Port	1	N/A
Type-C USB Port	1	N/A

1.4. Description of Test Facility

NVLAP Accreditation Code is 600167-0.

FCC Designation Number is CN5024

CAB identifier is CN0071.

CNAS Registration Number is L4595.

Test Firm Registration Number: 254912.

The 3m-Semi anechoic test site fulfils CISPR 16-1-4 according to ANSI C63.4:2014 and CISPR 16-1-4:2010 SVSWR requirement for radiated emission above 1GHz.

1.5. Test Equipment

Equipment	Manufacturer	Model	Serial no.	Calibrated date	Calibrated Due
Exposure Level Tester	Narda	ELT-400	N-0713	2023-10-18	2024-10-17
B-Field Probe	Narda	100cm ²	M-1154	2023-10-18	2024-10-17

Exposure Level Tester ELT-400 detailed parameters are as follows:

Common parameter	
Operating temperature	-10 °C ~ +50 °C
Operation humidity	< 95 % (30 °C) or < 29 g/m ³
Weight	910 g
Size	180 mm x 100 mm x 55 mm(Main engine) / 290 mm x 125 mm Ø (Probe)
Display	LCD backlit display, 4 refresh rates per second
Battery	Nimh battery (4 x Mignon, AA), rechargeable
Operating time, typical	12 h
Power supply	100 ~240 V AC / 47 ~ 63 Hz
Charging time, typical	2 hours
Recommended calibration cycle	24 months
Country of origin	Germany

1.6. Measurement Uncertainty

Test Item	Frequency Range	Uncertainty	Note
Field Strength Uncertainty	1Hz~400KHz	1%	(1)

(1). This uncertainty represents an expanded uncertainty expressed at approximately the 95% confidence level using a coverage factor of k=2.



Shenzhen LCS Compliance Testing Laboratory Ltd.

Add:101, 201 Bldg A & 301 Bldg C, Juji Industrial Park Yabianxueziwei, Shajing Street, Baoan District, Shenzhen, 518000, China

Tel: +(86) 0755-82591330 | E-mail: webmaster@lcs-cert.com | Web: www.lcs-cert.com

Scan code to check authenticity

1.7. Description of Test Modes

Equipment under test was operated during the measurement under the following conditions:

- Charging and communication mode

Test Modes:		
Mode 1	AC/DC Adapter(12V/1.5A)+EUT+mobile phone (Battery Status: <1%)	Record
Mode 2	AC/DC Adapter(12V/1.5A)+EUT+mobile phone (Battery Status: <50%)	Pre-tested
Mode 3	AC/DC Adapter(12V/1.5A)+EUT+mobile phone (Battery Status: 100%)	Pre-tested
Mode 4	AC/DC Adapter (9V/2A)+EUT+mobile phone (Battery Status: <1%)	Pre-tested
Mode 5	AC/DC Adapter (9V/2A)+EUT+mobile phone (Battery Status: <50%)	Pre-tested
Mode 6	AC/DC Adapter (9V/2A)+EUT+mobile phone (Battery Status: 100%)	Pre-tested
Mode 7	AC/DC Adapter (5V/2A)+EUT+mobile phone (Battery Status: <1%)	Pre-tested
Mode 8	AC/DC Adapter (5V/2A)+EUT+mobile phone (Battery Status: <50%)	Pre-tested
Mode 9	AC/DC Adapter (5V/2A)+EUT+mobile phone (Battery Status: 100%)	Pre-tested

Note: All test modes were pre-tested, but we only recorded the worst case in this report.

1.8. Coil Description

Config.	Mode	Descriptions
1	Standby (Flatbed Position) @ 115.4kHz	EUT Alone powered by AC/DC adapter
2	Operating (Flatbed Position) (Phone @ 115.4kHz, ~10%, 20~50%, and >75% Power Charging)	EUT with lightning to AC/DC Adapter & Wireless Charging to WPT Client. 15W: Direct Contact 15W: 2mm Airgap, 2mm Shift Top as Worst Case Position

1.9. Coil Size

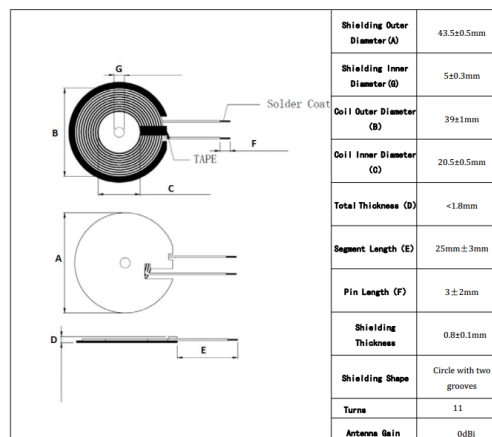

(Unit: mm)





1.10. Coil Specifications

Item	Parameter
Input inductance:	Transmitter 1: 6.3 $\mu\text{H} \pm 10\%$
Material of enclosure(s):	Multiple strands of enamelled wire
Number of turns:	Transmitter 1: 11 turns

1.11. Duty Cycle

Mode	ON Timems (ms)	Periodms (ms)	Duty Cycle% (%)
Operating(110.1-205kHz)	/	/	100

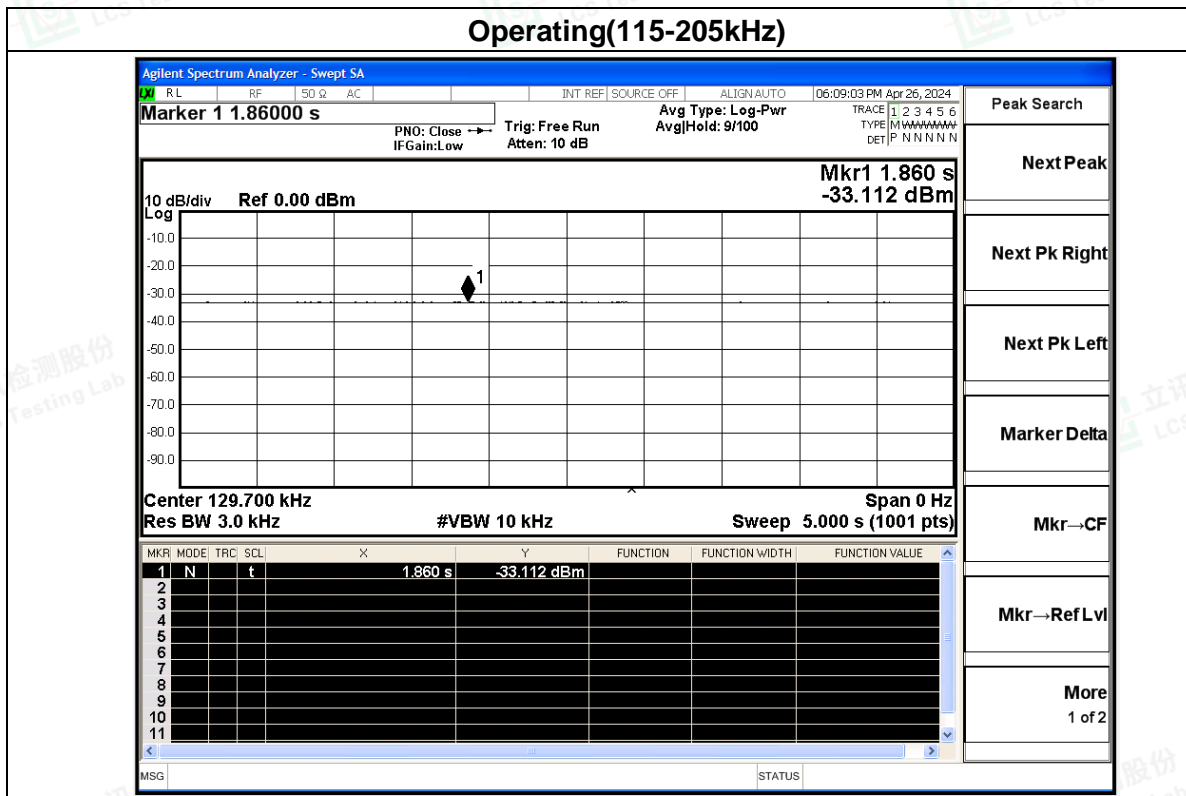



2. TEST METHODOLOGY

2.1. Reference Evaluation Method

[ANSI C95.1-1999](#): IEEE Standard for Safety Levels with Respect to Human Exposure to Radio Frequency Electromagnetic Fields, 3 kHz to 300 GHz.

[FCC KDB publication 680106 D01 RF Exposure Wireless Charging Apps v04](#): RF Exposure Considerations for Low Power Consumer Wireless Power Transfer Applications

[FCC CFR 47 part1 1.1310](#): Radiofrequency radiation exposure limits.

[FCC CFR 47 part2 2.1093](#): Radiofrequency radiation exposure evaluation: portable devices

[FCC CFR 47 part 18.107](#): Industrial, Scientific, and Medical Equipment

2.2. Limit

§1.1310: The criteria listed in the following table shall be used to evaluate the environment impact of human exposure to radio frequency (RF) radiation as specified in §1.1307(b), except in the case of portable devices which shall be evaluated according to the provisions of FCC part 2.1093 of this chapter.

Table 1 to §1.1310(e)(1) - Limits for Maximum Permissible Exposure (MPE)

Frequency range (MHz)	Electric field strength (V/m)	Magnetic field strength (A/m)	Power density (mW/cm ²)	Averaging time (minutes)
(i) Limits for Occupational/Controlled Exposure				
0.3-3.0	614	1.63	*(100)	≤6
3.0-30	1842/f	4.89/f	*(900/f ²)	<6
30-300	61.4	0.163	1.0	<6
300-1500	/	/	f/300	<6
1500-100000	/	/	5	<6
Limits for (ii) General Population/Uncontrolled Exposure				
0.3-1.34	614	1.63	*(100)	<30
1.34-30	824/f	2.19/f	*(180/f ²)	<30
30-300	27.5	0.073	0.2	<30
300-1500	/	/	f/1500	<30
1500-100000	/	/	1.0	<30

f = frequency in MHz

* = Plane-wave equivalent power density

Note 1: Occupational/controlled exposure limits apply in situations in which persons are exposed as a consequence of their employment provided those persons are fully aware of the potential for exposure and can exercise control over their exposure.

Note 2: General population/uncontrolled exposure limits apply in situations in which the general public may be exposed, or in which persons who are exposed as a consequence of their employment may not be fully aware of the potential for exposure or cannot exercise control over their exposure.

2.3. Test Setup Diagram



Shenzhen LCS Compliance Testing Laboratory Ltd.

Add:101, 201 Bldg A & 301 Bldg C, Juji Industrial Park Yabianxueziwei, Shajing Street, Baoan District, Shenzhen, 518000, China

Tel: +(86) 0755-82591330 | E-mail: webmaster@lcs-cert.com | Web: www.lcs-cert.com

Scan code to check authenticity

For mobile exposure conditions:

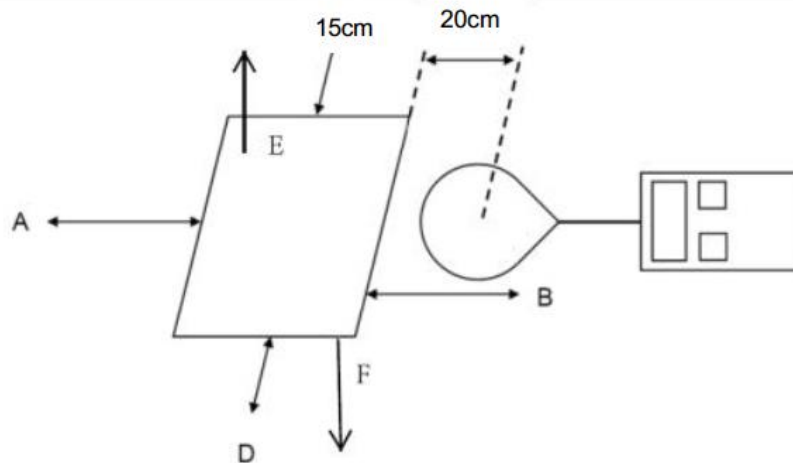

Note: The distance of the points A/B/C/D is 15cm, and the point E is 20cm.

For portable exposure conditions:

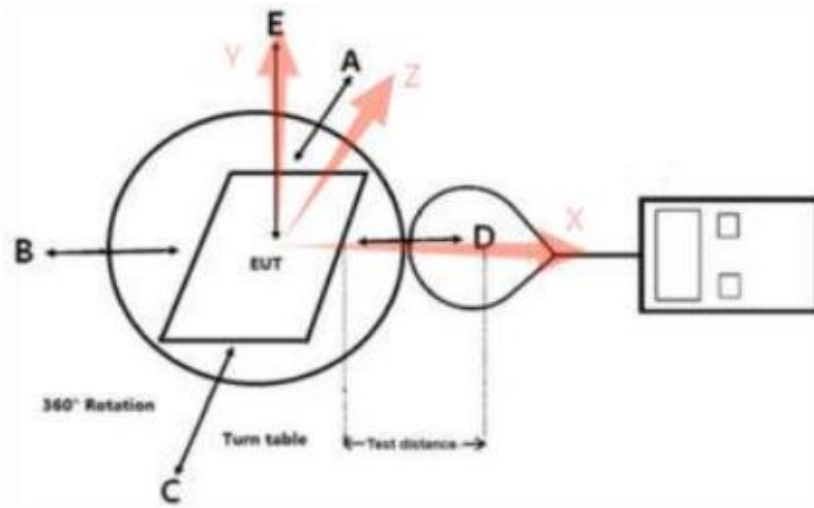

Note: The distance of the points A/B/C/D/E/F is 0,2,4,6,8,10,12,14,16,18, 20cm. The values tested by the probe are X, Y, and Z on three axes perpendicular to the edge of the device. Top and bottom side coincident with the axis(Y) of the main coil.

2.4. Measurement Procedure





For mobile exposure conditions:

- a. The RF exposure test was performed in anechoic chamber.
- b. E and H-field measurements should be made with the center of the probe at a distance of 15 cm surrounding the EUT and 20 cm above the top surface of the primary/client pair.
- c. The highest emission level was recorded and compared with limit.
- d. The EUT was measured according to the KDB 680106 D01 Wireless Power Transfer v04.

For portable exposure conditions:

- a. The RF exposure test was performed in anechoic chamber.
- b. Perform H-field measurements for each edge/top surface of the host/client pair at every 2 cm, starting from as close as possible out to 20 cm
- c. The highest emission level was recorded and compared with limit.
- d. The EUT was measured according to the KDB 680106 D01 Wireless Power Transfer v04.

2.5. Equipment Approval Considerations of KDB 680106 D01v04

Requirements of KDB 680106 D01	Description
WPT operating frequency (or frequencies).	The device operate in the frequency range 110KHz~205KHz
Number of radiating structure(Coil)	Only one radiated Coil
Conducted power for each radiating structure.	Maximum 15W
§ 2.1091-Mobile or § 2.1093-Portable demonstrated scenarios of operation, including RF exposure compliance information	Mobile and Portable Device
Maximum distance from the WPT transmitter at which, by design, a load can be charged (including slow-charging operations)	Charing with the load directly contact



3. TEST RESULTS

For portable exposure condition:

- (1). The portable test modes have covered the considerations of the mobile test, only record the test data of the portable conditions in this report.
- (2) Operating modes with client device (1 %, 50%, 99% battery status of client device) have been test, only show the data of worst case of 1% battery status of client device.
- (3) Test performed with all the radiating structures operating at maximum power at the same time.
- (4) H-field measurements are taken along all three axes the device from 0cm~20cm in 2cm minimum increment for each edge surface of the host/client pair. **If the center of the probe sensing element is more than 5mm from the probe outer edge, the field strengths need to be estimated for the positions that are not reachable.**
- (5) According to Calibration information and specification about ETL-400 Probe, The Probe ETL-400 Probe's sensitive elements center is located in the probe's center, and **the distance from the sensitive elements center to the tip of probe is 6.25cm.**
- (6) The actual 0cm, 2cm, 4cm and 6cm field strengths need to be estimated for the positions that are not reachable via numerical calculation.
- (7) Use **Biot-Savart formula** theory to estimate the strength of the magnetic field that the measuring instrument cannot measure. According to Biot-Savart formula:

Top & Bottom Side:



$$B = \frac{\mu_0 * I * N * R^2}{2 * (R^2 + x^2)^{3/2}}$$

Front, left, right & rear Side:

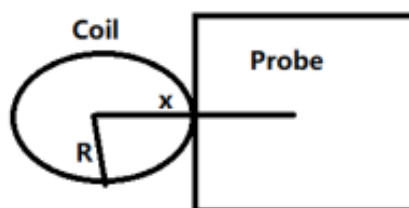

$$B = \frac{\mu_0 * I * N}{2 * x}$$





B(Unit:A/m): means H-field value;
 μ_0 is space permeability; $\mu_0=4\pi*10^{-7}$;

I(Unit:A): A current element passing through a radiated coil;

R(Unit:m): means the Radius of radiated coil,According to provided Antenna specification:

$R=40/2=20mm=0.20m$;

Test Distance(Unit:m): The distance from the sensing element of the probe to the edge of the device surface.

x(Unit:m): means the center of the coil to the sensing elements of the probe. (For top & bottom side: x=test distance; For other side: x=test distance+R)

N: Number of turns, according to providing "Antenna specification" files: N=10.

(8) For validation purposes: If the value to show a 30% agreement between the mode and the probe measurements for the two closest points to the device surface, and with 2cm increments. Then this extrapolation method is reasonable.

3.1 Validation results for the numerical calculation model

- a) Measure with probe directed contact(test distace:6.25cm)
 - b) Using Biot-Savart formula to calculate estimated results at test distace of 8cm and 10 cm;
 - c) measure at test distace of 8 cm and 10cm;
 - d) Compares the estimated results and measured result, the varation should not be greater than 30%;
- Conclusion: The numerical calculation model is valid.

Distance(cm)	Test condition: Mode 1																	
	Top			Bottom			Left			Right			Front			Back		
	Mea.	Est.	Var.	Mea.	Est.	Var.	Mea.	Est.	Var.	Mea.	Est.	Var.	Mea.	Est.	Var.	Mea.	Est.	Var.
6.25	0.0423	/	/	0.0375	/	/	0.0197	/	/	0.0181	/	/	0.0172	/	/	0.0159	/	/
8	0.0233	0.0213	-8.4	0.0214	0.0189	-11.6	0.0162	0.0163	0.4	0.0167	0.0149	-10.8	0.0153	0.0142	-7.5	0.0117	0.0131	11.7
10	0.0107	0.0113	5.9	0.0106	0.01	-5.3	0.0131	0.0135	3.0	0.0106	0.0124	17.4	0.0134	0.0118	-12.3	0.0102	0.0109	6.6
Mea.-Measured H-field(A/m); Est.-Estimated H-field(A/m); Var.-Variation between measured and estimated value(%);																		

3.2 Final H-Field Emission level with a combination of measured and estimated results.

Test condition: Mode 1

Distance(cm)	Type	Result(A/m)						Limit(A/m)
		Top	Bottom	Left	Right	Front	Back	
0	Estimate	1.4942	1.3246	0.0813	0.0747	0.071	0.0656	1.63
2	Estimate	0.5283	0.4683	0.0406	0.0373	0.0355	0.0328	1.63
4	Estimate	0.1336	0.1185	0.0271	0.0249	0.0237	0.0219	1.63
6	Estimate	0.0472	0.0419	0.0203	0.0187	0.0177	0.0164	1.63
8	Measured	0.0233	0.0214	0.0162	0.0167	0.0153	0.0117	1.63
10	Measured	0.0107	0.0106	0.0131	0.0106	0.0134	0.0102	1.63
12	Measured	0.0061	0.0055	0.0122	0.0105	0.0115	0.0090	1.63
14	Measured	0.0043	0.0034	0.0107	0.0101	0.0082	0.0073	1.63
16	Measured	0.0026	0.0027	0.0079	0.0084	0.0074	0.0074	1.63
18	Measured	0.0018	0.0018	0.0086	0.0079	0.0082	0.0061	1.63
20	Measured	0.0016	0.0012	0.0080	0.0076	0.0057	0.0060	1.63

3.3 Conclusion

A minimum safety distance of 0 cm to the antenna is required when the device is charging a smart phone for portable exposure. The detected emissions are below the limitations according FCC KDB 680106 and confirmed by the FCC according to KDB Inquire.





4. TEST SETUP PHOTOS

(The separation distance from the geometric center of the probe to the edge of the device is 6.25cm)

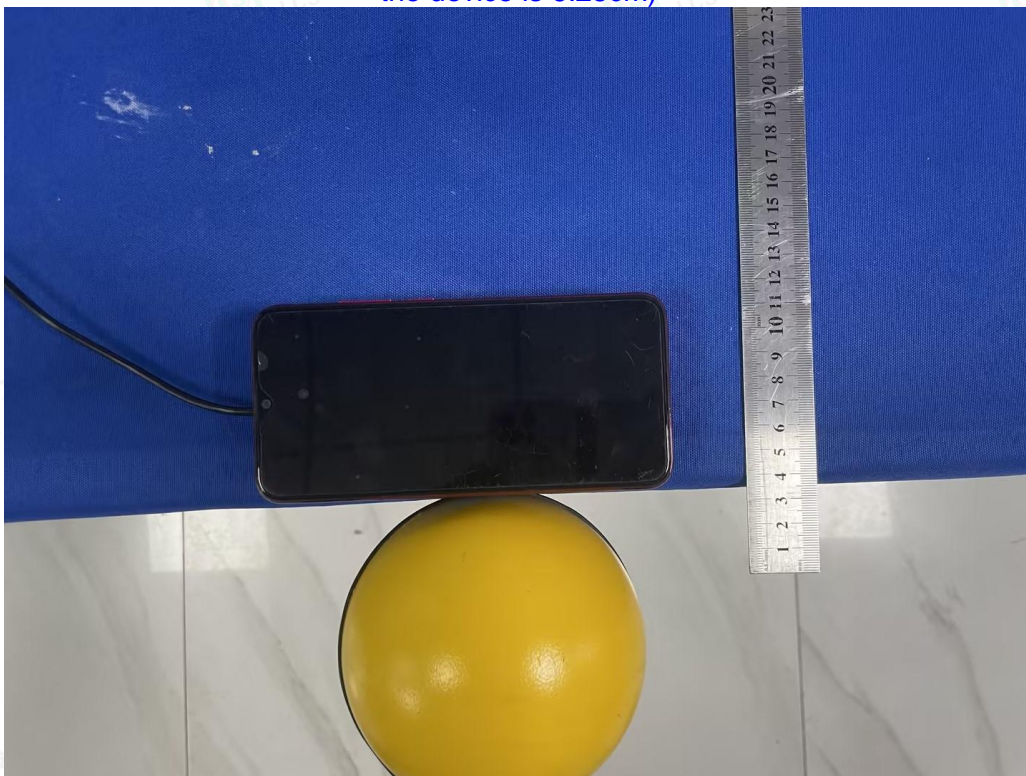

0cm-Left

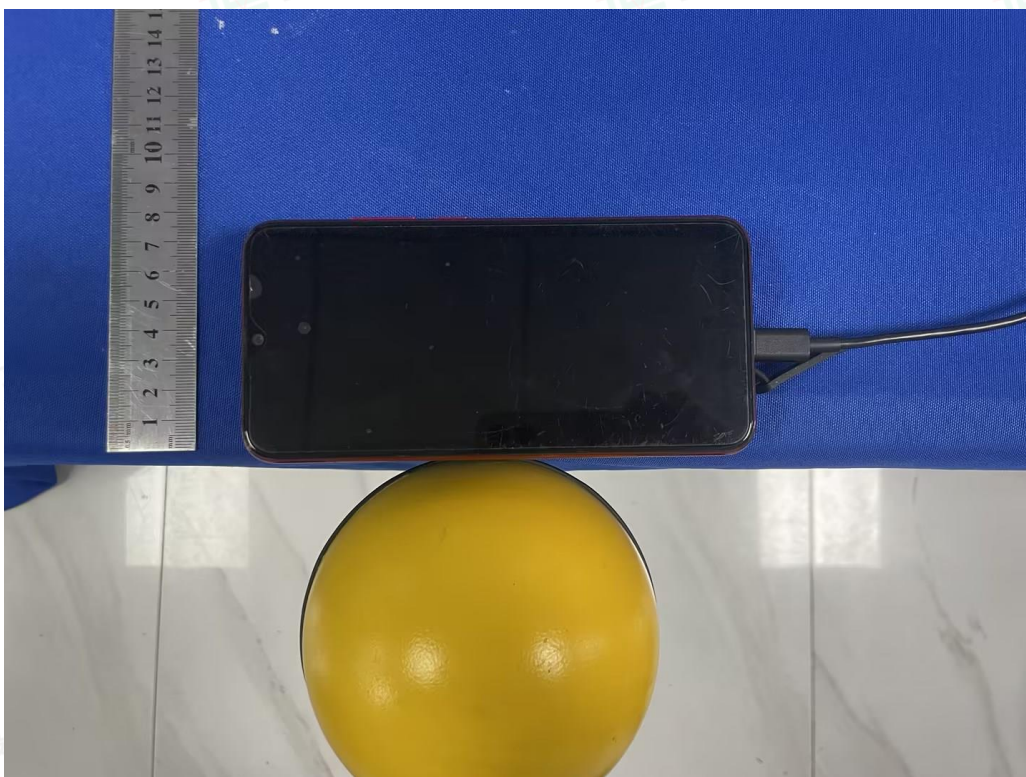

0cm-Right



Shenzhen LCS Compliance Testing Laboratory Ltd.

Add:101, 201 Bldg A & 301 Bldg C, Juji Industrial Park Yabianxueziwei, Shajing Street, Baoan District, Shenzhen, 518000, China

Tel: +(86) 0755-82591330 | E-mail: webmaster@lcs-cert.com | Web: www.lcs-cert.com

Scan code to check authenticity

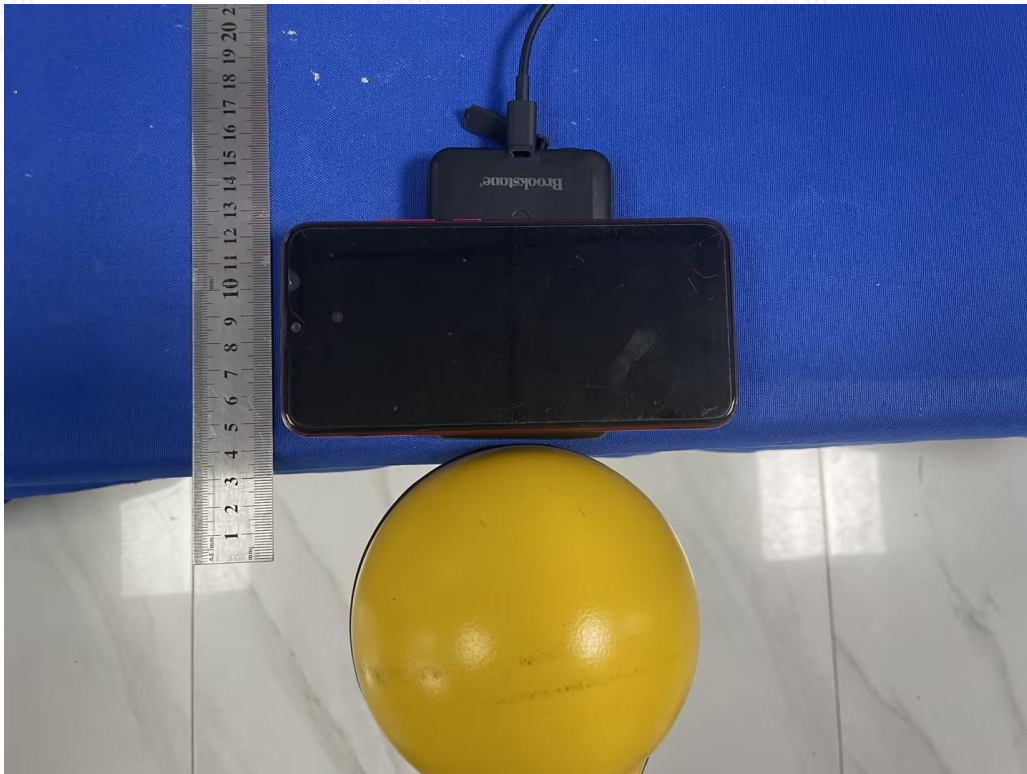

0cm-Top

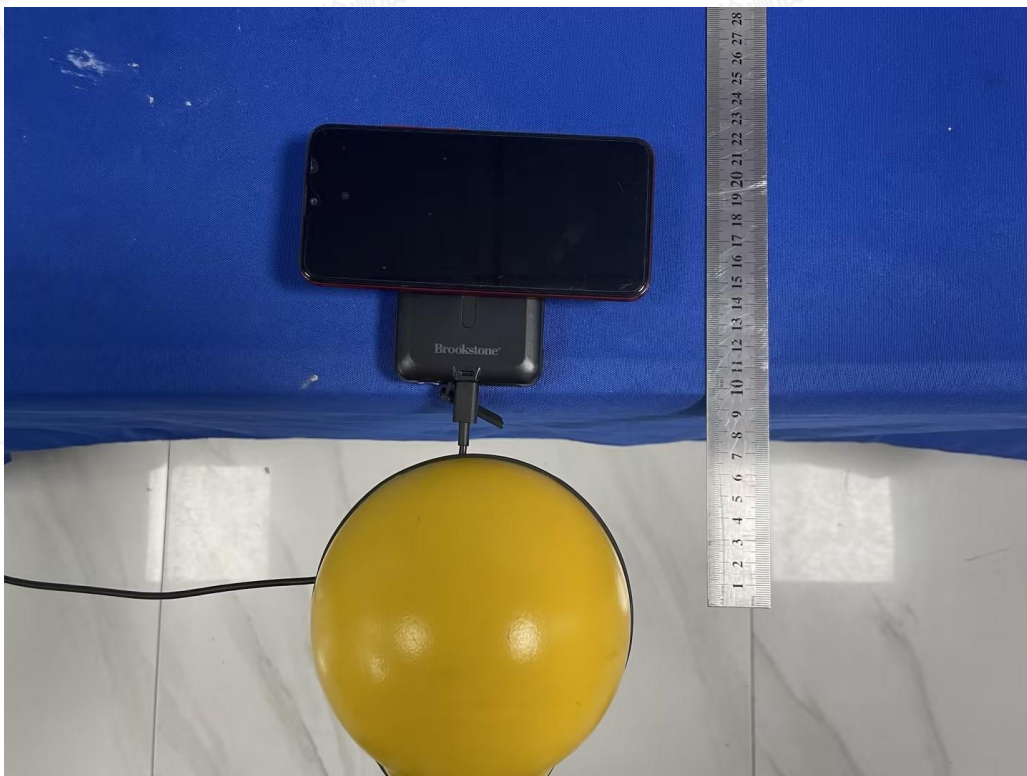

0cm-Bottom



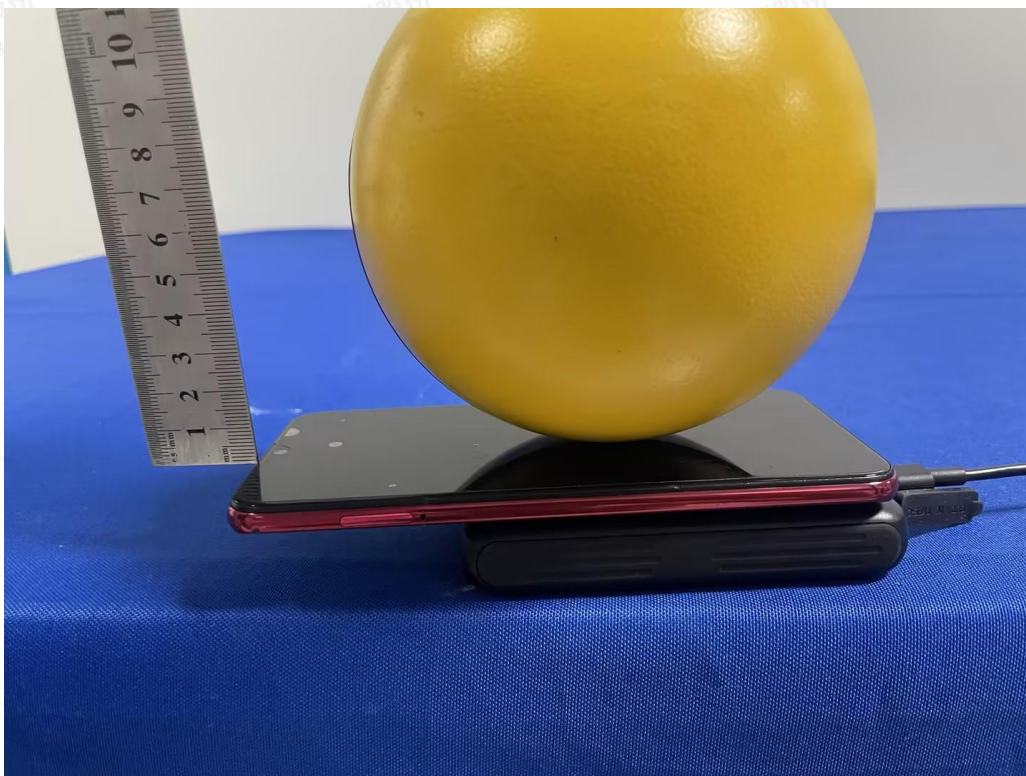

0cm-Front

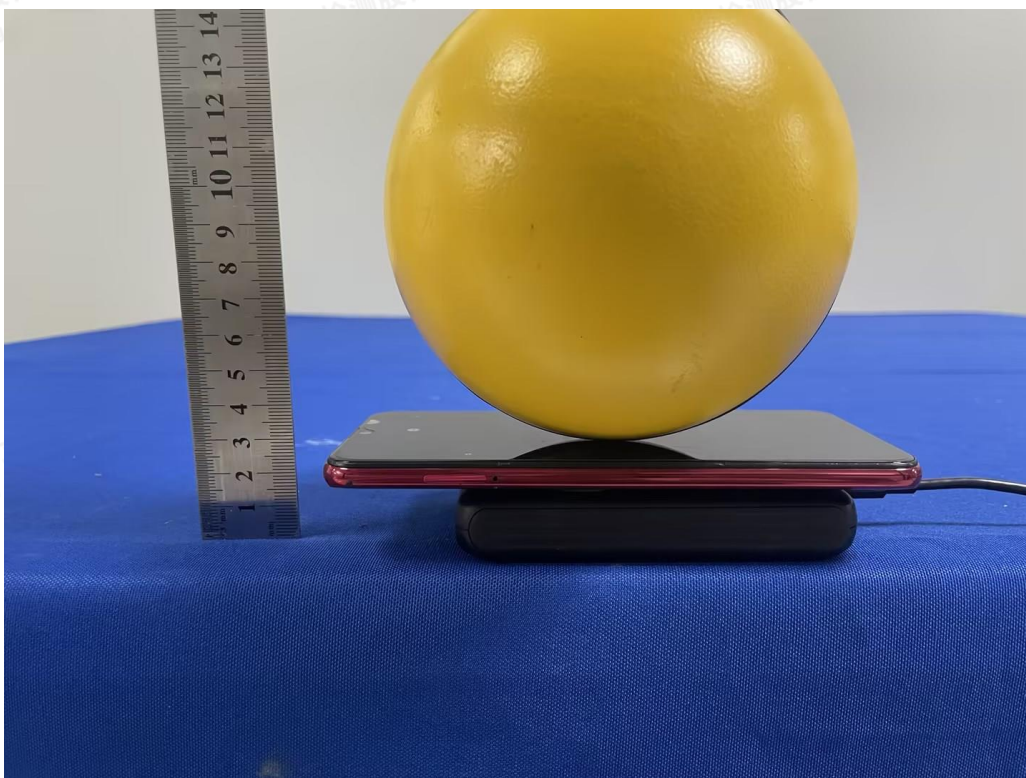

0cm-Back



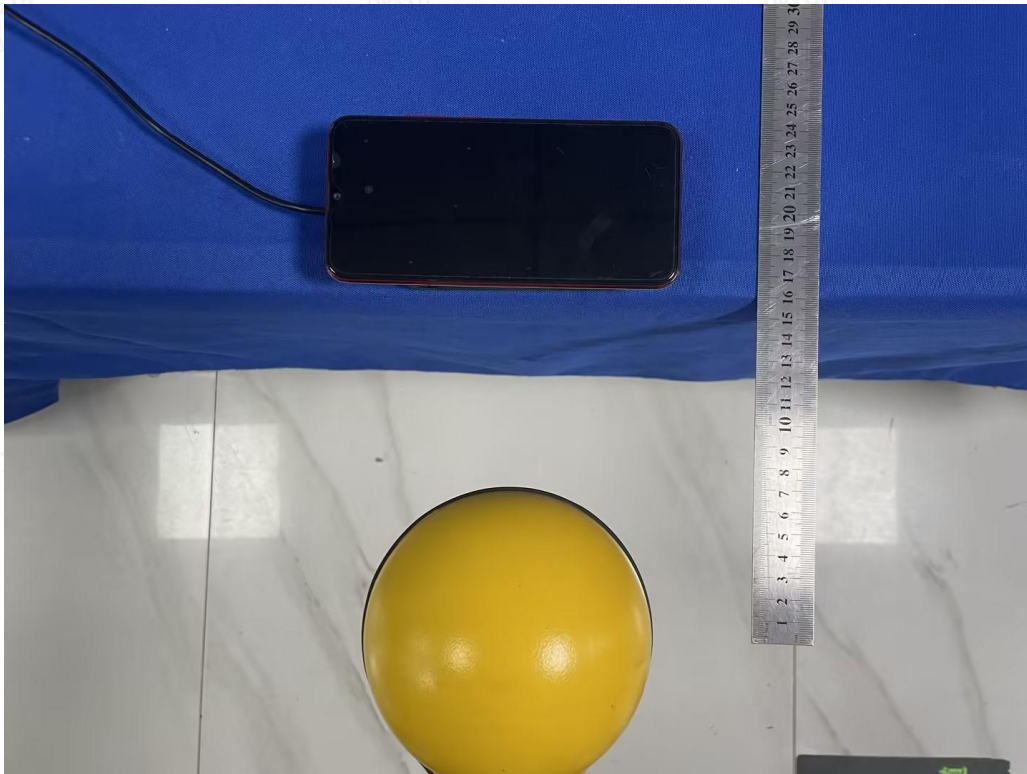

20cm-Left

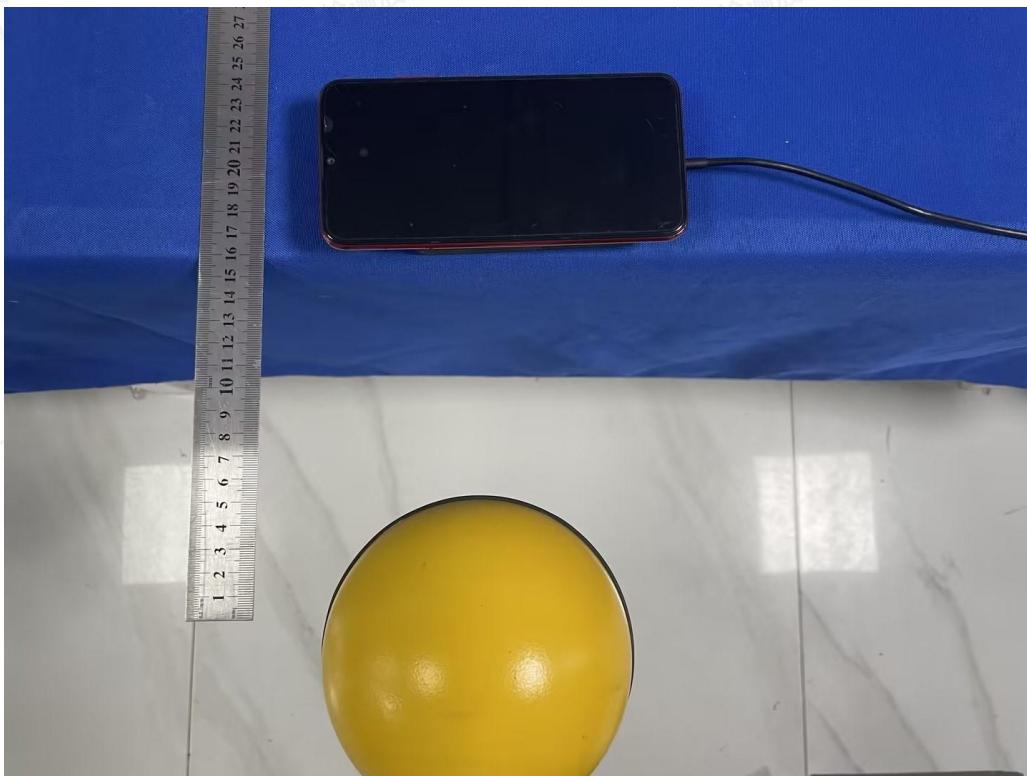

20cm-Right



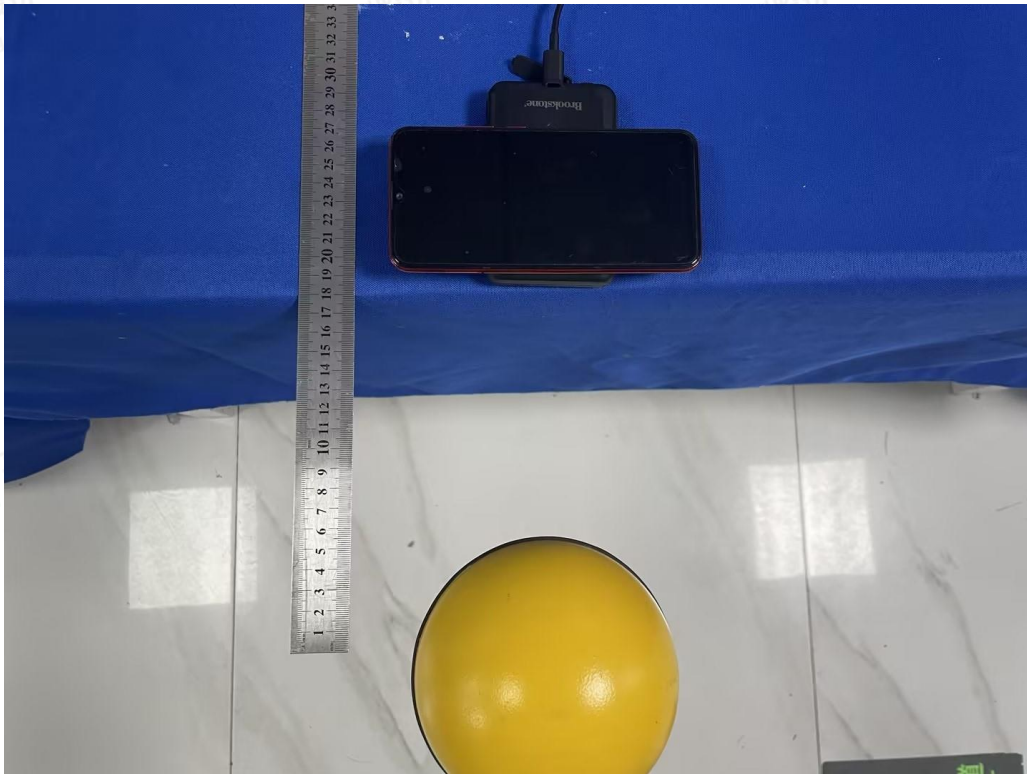

20cm-Top

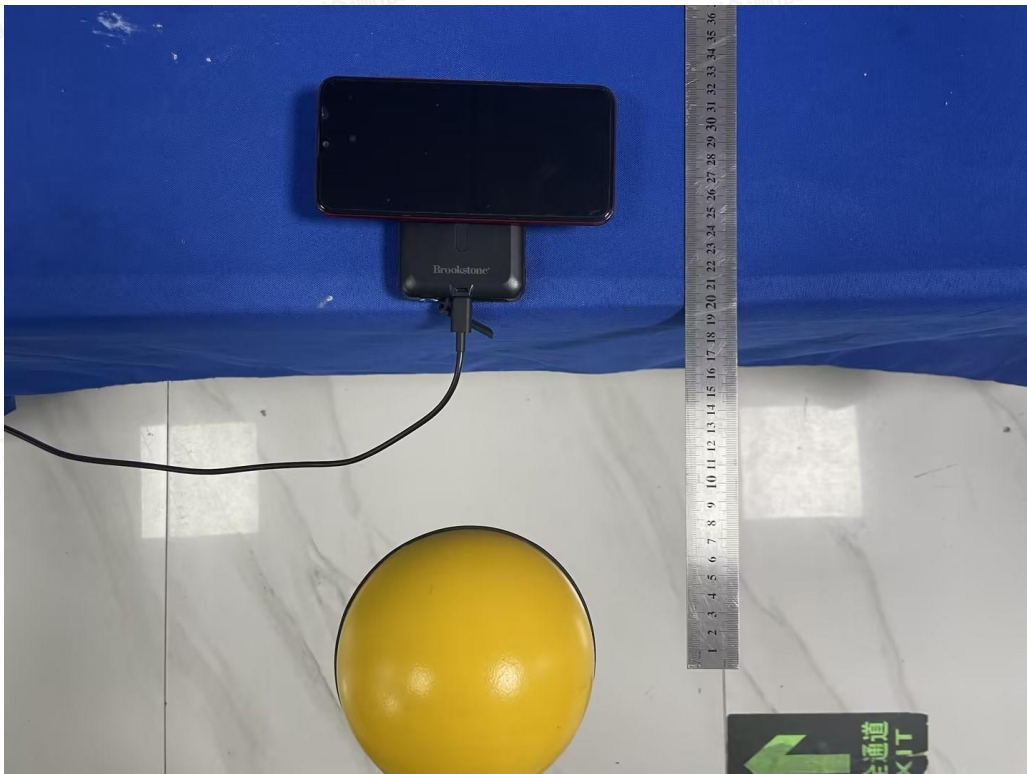

20cm-Bottom



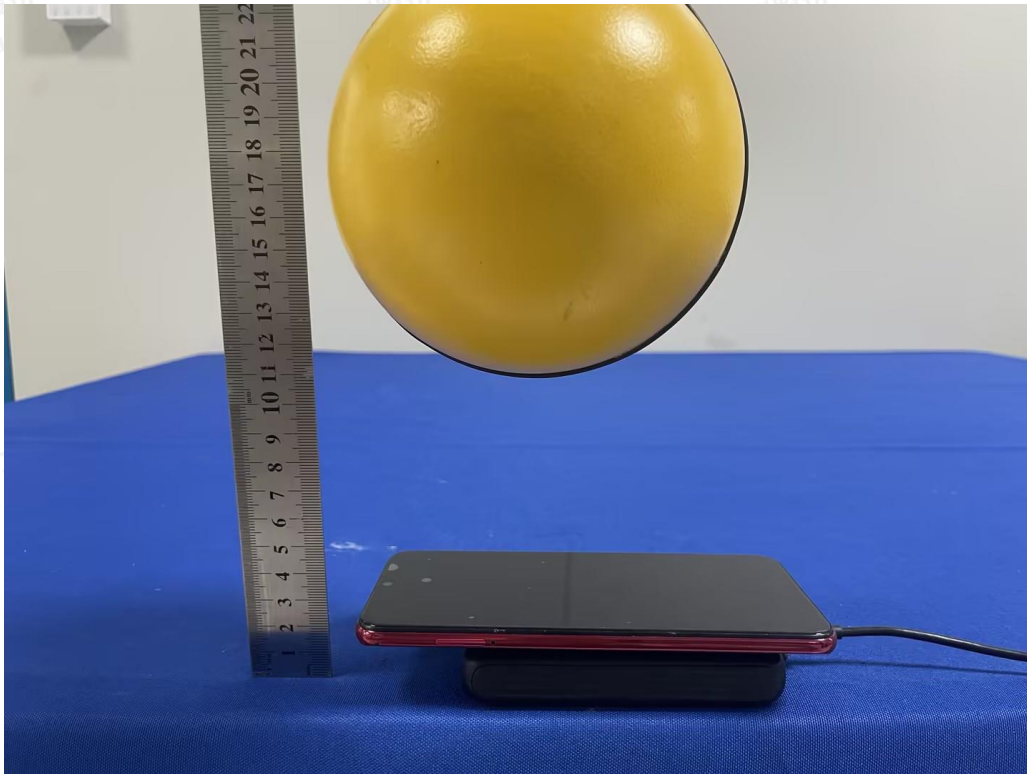

20cm-Front

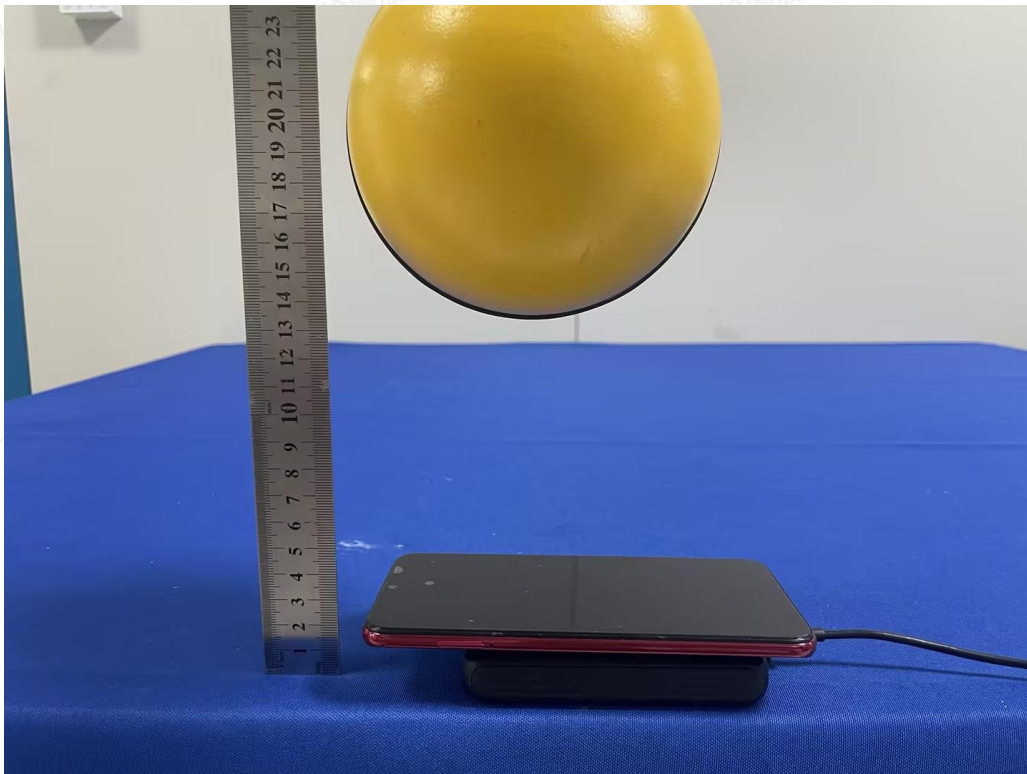

20cm-Back

-----THE END OF REPORT-----

