

## Wireless AP Module\_9 series

### Feature Highlights

- Low supply operation: 2.4V – 3.6V
- Compact size: 35.5mm x 37.5 mm, ideal for embedded system integration such as access point
- Low-power consumption
- Using M2C patented Platanus™ platform for smart-networking application
- ARM Cortex-M0 up to 32MHz clock rate, with embedded 128 KB flash memory and 1MB SRAM
- Frequency range: 903~927MHz
- Data bandwidth: up to 500kbps
- High receiver sensitivity: -96dBm at 500kbps
- Integrated power amplifier up to 11dBm
- Pre-matched RF front-end, reducing design hassles
- Support UART and GPIOs as interface with other LAN modules in the embedded system
- Supports 128-node “star” and 16000-node “tree” network infrastructure.

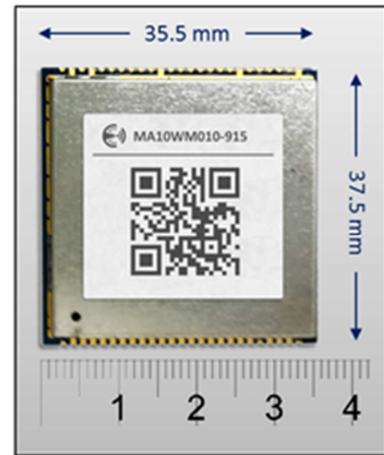

### Applications

- Comply with FCC Part 15C
- Innovative turn-key solution for ultra-low power wireless link
- Remote control systems
- Wireless sub-metering (plug)
- Home automation
- Wireless sensor network
- Telemedicine service
- Wireless lighting control
- Smart rack for logistics system

### Descriptions

#### Overview

MA903A1 is an easy-to-integrate Access Point embedded module for hosting ultra-low-power wireless-link application. With state-of-the-art Platanus™ protocol and networking kit, large network (up to 16000 nodes) can be easily formed. Equipped with ISM-band RF operated at 868MHz/915MHz bands and popular ARM 32-bit MCU along with embedded flash memory and SRAM, MA903A1 is an ideal embedded solution for system integrator to develop wireless applications with no worry about design hassles, both wireless and networking.

#### Easy to Integrate and Use

Designed as the embedded module, MA903A1 has only the board area of 35.5mm x 37.5mm, compact enough for most embedded system design. A pre-matched 50 ohm port is ready to be used with on-board or external antenna. The RF matched network is calibrated to optimize the RF performance when the module is shipped, saving the design hassles for application designers.

There are total 50 stamp pads on MA903A1 with multiple digital interfaces: UART, GPIOs, and JTAGs. This brings the design flexibility to end applications that MA903A1 is easy to interface with other LAN modules. Through the robust wireless link, controlled/collected information from End Device (ME10WM010) can be easily sent to the upper application layers and devices.

### Ready-to-go Sub-GHz Radio Link with Excellent Reliability

The wireless link utilizes the sub-GHz radio band, requiring no special licenses (free-ISM) and certification. MA903A1 comply with the ETSI EN 300 220 and FCC part 15 regulations. Compared to the crowded 2.4GHz band, sub-GHz radio link, given the similar power level, allows better distance and penetration especially in the hostile indoor environment. In particular, with WiFi and Bluetooth crowding the 2.4GHz band these days, MA903A1 is immune from all 2.4GHz interference and delivers the reliable wireless link. With the data rate of 500kbps in 2FSK, the bandwidth use efficiency is 16x better than 2.4GHz Zigbee (2MHz). MA903A1 can deliver the link budget up to 107dB (TX maximum power: 11dBm, RX Sensitivity level: -96dBm) without adding external components. The Line-of-Sight (LOS) link distance is over 300 meters\*.

\* tested with 63-byte payload with PER of 1%. This may be variable depending on test environment

### Robust Two-way Networking

MA903A1 uses a built-in protocol Platanus™ to support “two-way” networking, saving the SI’s design headache of linking large amounts of wireless nodes. Used with ME10WM010 (End Device), MA903A1 can support two types of network hierarchies: STAR and TREE (as shown below). When MA903A1 is configured in STAR networking, up to 128 nodes can be supported. When MA903A1 is configured in TREE network, up to 16000 nodes can be supported. Asymmetrical downlink and uplink are supported to balance between network reliability and response time, and the programmable network parameters can be used to optimize for each use scenario.

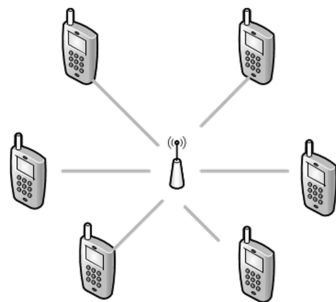

Figure 1. STAR configuration

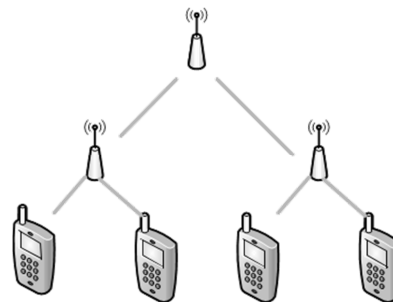

Figure 2. TREE configuration

### Upper Layer Connectivity

MA903A1 is shipped with the UART interface and the managing software library. Thus the upper-layer devices, such as TCP/IP gateway, can easily access MA903A1 in the network, as the Access Point to the private network, to exchange data “interactively” via the Ethernet or WiFi. This makes the cloud-based application developer easy to hook up with the privately-own network when building with MA903A1.

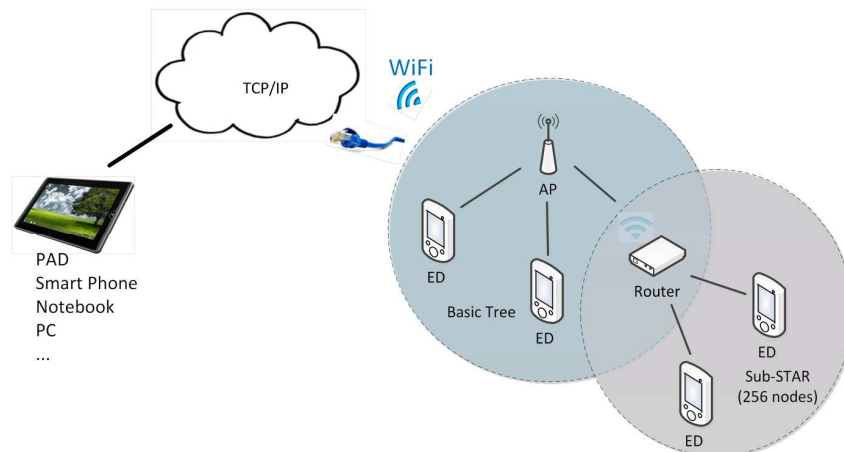

Figure 3. Network Structure

### Ideal Platform for Low-power Application Development

MA903A1 is powered by ARM Cortex MCU with clock up to 32MHz with embedded 128K-Byte flash and 1M-Byte SRAM, to support built-in Platanus™ networking library from M2C and for peripherals. For details, please refer to the associated documentation.

Using Platanus™ protocol with M2C MA903A1 (Access Point) and/or MR1001 (Router), the formed network can achieve ultra-low power consumption for battery-friendly applications. The network acts in the cellular-like behavior, with sleep time configurable from 5 seconds up to 90 seconds. Details of power consumption can be referred to the datasheet of ME10WM010.

### Pin Diagram & Components Placement

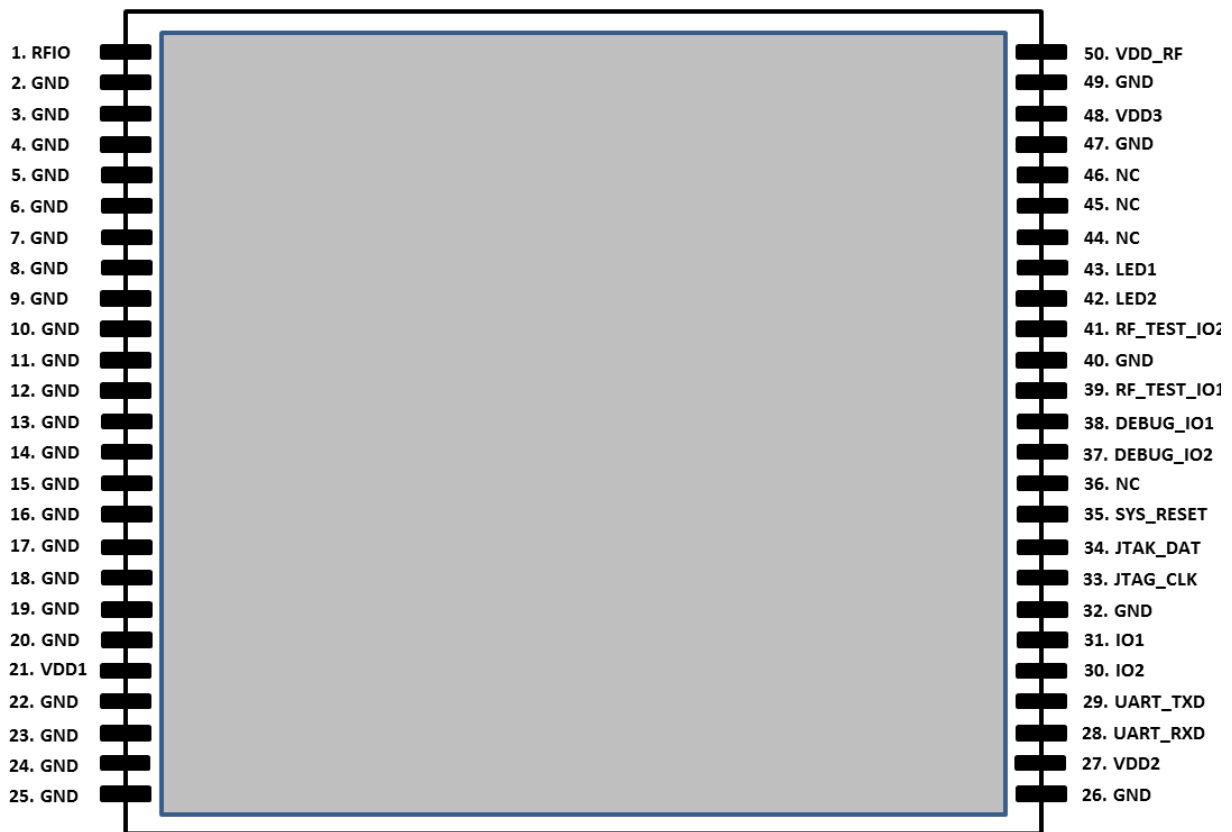

Figure4. Pin diagram

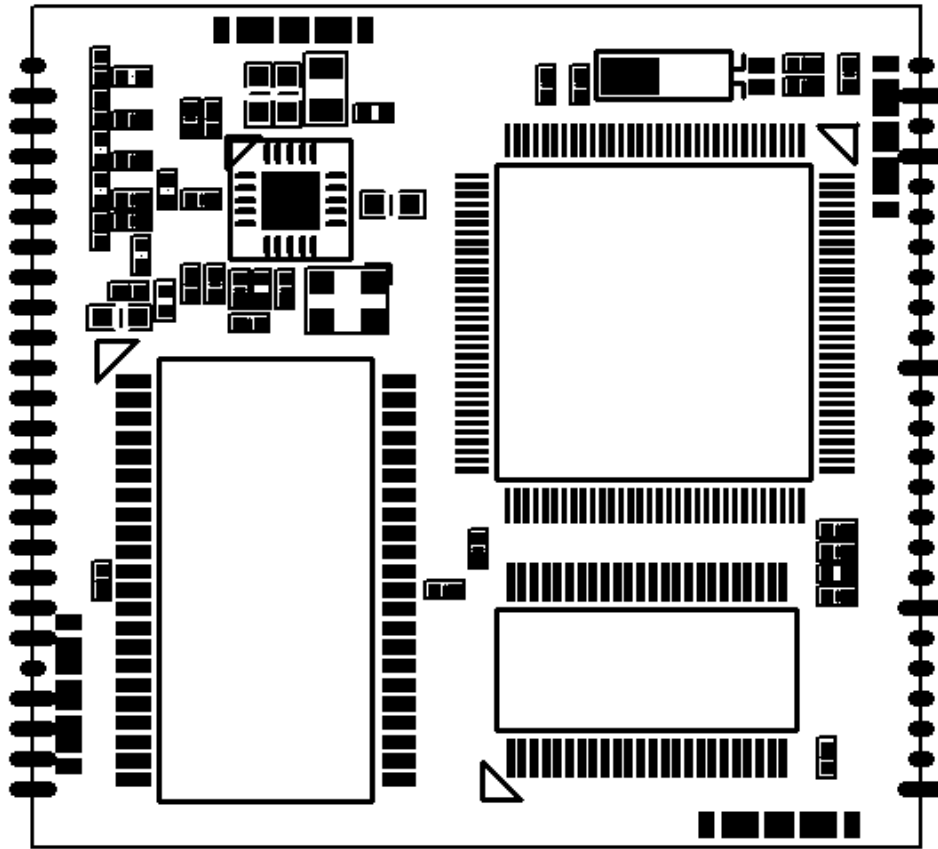

Figure5. Pin diagram



## Table of Contents

<b>1</b>	<b>Electrical Characteristics.....</b>	<b>6</b>
<b>2</b>	<b>Pin Out.....</b>	<b>9</b>
<b>3</b>	<b>Memory.....</b>	<b>10</b>
<b>4</b>	<b>Serial Interfaces.....</b>	<b>10</b>
4.1	General-purpose I/O (GPIO) .....	10
4.2	UART .....	10
<b>5</b>	<b>How to Use MA903A1 to Design &amp; Compliance with FCC requirements.....</b>	<b>11</b>
5.1	50ohm RF Trace Calculation.....	11
5.2	PCB Design .....	12
5.3	PCB Layout Recommend.....	14
5.4	PCB Layout Guide.....	14
<b>6</b>	<b>Available Antenna List .....</b>	<b>15</b>
<b>7</b>	<b>Regulation Approval.....</b>	<b>19</b>
<b>8</b>	<b>Recommended PCB Footprint.....</b>	<b>19</b>
<b>9</b>	<b>Contact Information.....</b>	<b>20</b>
<b>10</b>	<b>Ordering Information.....</b>	<b>20</b>



# 1 Electrical Characteristics

Table 1. Absolute Maximum Rating

Parameter	Symbol	Condition	Min	Typ	Max	Unit
Supply Voltage	$V_{dd}$	VCC to GND	-0.3		3.6	Volt
Voltage on I/O Pin	$V_{IO}$		-0.3		$V_{cc} + 0.3$	Volt
Temperature Range for Storage	$T_{sto}$		-10		+85	°C
Operation Temperature	$T_{opt}$		-10		+45	°C

Table 2. DC Characteristics

Parameter	Symbol	Condition	Min	Typ	Max	Unit
Power Supply	$V_{dd}$	see note 1	2.4		3.6	V
Low-power Current Consumption	$I_{normal}$	(see below)		N/A		
	$I_{standby}$	Standby mode		4		mA
RX Mode Current Consumption TX Mode Current Consumption	$I_{RX,MB}$	923MHz band Data rate = 500kbps 2FSK			30	mA
TX Mode Current Consumption Read/Write Memory	$I_{TX1, 11dBm}$	Output power = 11.28dBm			50	mA
	$I_{BB}$	Read/Write Memory			60	mA
Linking and Data Transmitting	$I_{total}$	System Linking, Transmit and Receive Data			TBD <100	mA

Note 1: all performance parameters are guaranteed at  $V_{dd} = 3.3V$

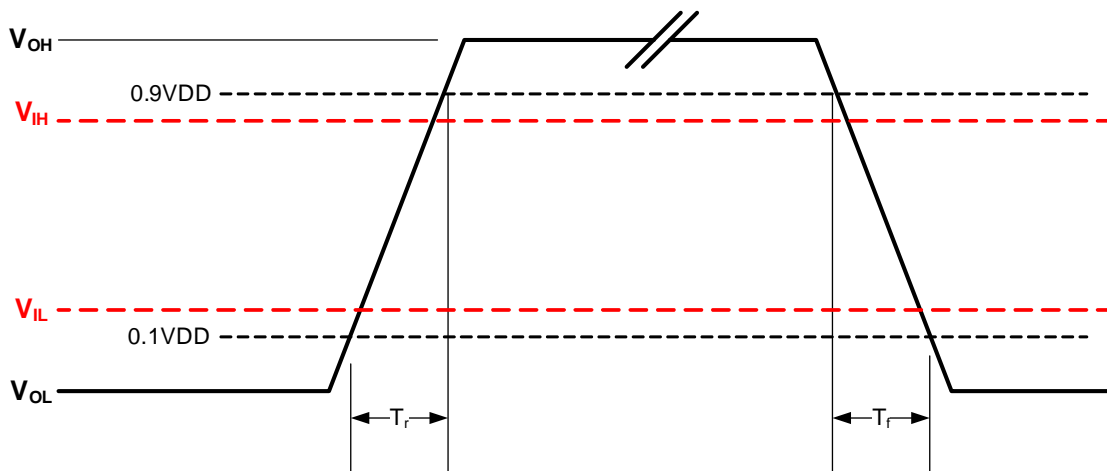

Table 3. AC Characteristics

Parameter	Symbol	Condition	Min	Typ	Max	Unit
<b>RF</b>						
Frequency Range	$F_{915M}$		903		927	MHz
RX Sensitivity	$P_{Rx\_500K}$	BER < 0.1% 2FSK, BT=0.5 500Kbps		-96		dBm
Saturation Power Level	$P_{sat}$			10		dBm
RSSI Range	$RES_{RSSI}$		-82		-58	dBm
Output TX Power	$P_{out}$			7		dBm
RF Data Rate	DT			500		Kbps
Link Distance	$R_{link}$	Line-of-Sight 20-byte packet length PER<1% Pout = 10dBm		250		Meters
Link Distance	$R_{link}$	Line-of-Sight 20-byte packet length PER<1% Pout = 0dBm		110		Meters

**Table 4. Digital IO Specification**

Parameter	Symbol	Condition	Min	Typ	Max	Unit
Rise Time	$T_r$	10% to 90% of VCC CL=10pF, DR<1:0>=11		10		ns
Fall Time	$T_f$	10% to 90% of VCC CL=10pF, DR<1:0>=11		10		ns
Logic "H" Input Level	$V_{IH}$			VDD-0.6		V
Logic "L" Input Level	$V_{IL}$			0.6		V
Input Capacitance	$C_{pin}$			1		pF
Input Impedance	$Z_{pin,hiZ}$	DC, Configured as hi-Z	10M			$\Omega$
	$Z_{pin,pl}$	DC, Configured as pull-low		100K		$\Omega$
	$Z_{pin,ph}$	DC, Configured as pull-high		100K		$\Omega$
Maximal Output Current	$I_{drive}$	programmable	1	4	8	mA
Logic "H" Output Level	$V_{OH}$			VDD-0.5		V
Logic "L" Output Level	$V_{OL}$			0.5		V

**Digital IO Specification Annotation**

**Figure6. I/O level diagram**



## 2 Pin Out

All VDDs are rated from 2.4V to 3.6V.

Pin #	Pin Name	Description	Type[1]	I/O/PWR
1	RFIO	RF Signal 50 ohm	IO	RF
2~20, 22~26, 32, 40, 47, 49	GND	Board ground	G	0
21	VDD1	Module Power Input. 2.4V~3.6V VDD1+VDD2+VDD3+VDD_RF 150mA Requirement	P	PWR
27	VDD2	Module Power Input. 2.4V~3.6V VDD1+VDD2+VDD3+VDD_RF 150mA Requirement	P	PWR
28	UART_RXD	UART_RXD, Baud Rate = 460.8kbps	D/A	IO
29	UART_TXD	UART_TXD, Baud Rate = 460.8kbps	D/A	IO
30	IO2	GPIO	D	IO
31	IO1	GPIO	D	IO
33	JTAG_CLK	ICE CLK (debugger)	D	I
34	JTAG_DAT	ICE DATA IN (debugger)	D	IO
35	SYS_RESET	External reset input, No need RC Delay [2]	SYS	SYS
36, 44~46	NC	No Connection		
37	DEBUG_IO2	Debug UART_TXD, No connection	D	O
38	DEBUG_IO1	Debug UART_RXD, No connection	D	I
39	RF_TEST_IO1	RF Test Pin Data_Out, No connection	D	O
41	RF_TEST_IO2	RF Test Pin CLK_Out, No connection	D	O
42	LED2	LED Index, Driver current 3mA	D	IO
43	LED1	LED Index, Driver current 3mA	D	IO
48	VDD3	Module Power Input. 2.4V~3.6V VDD1+VDD2+VDD3+VDD_RF 150mA Requirement	P	PWR
50	VDD_RF	Module Power Input. 2.4V~3.6V VDD1+VDD2+VDD3+VDD_RF 150mA Requirement	P	PWR

[1] D=digital, A=analog, P=power, G=ground

[2] Set this pin low reset chip to initial state, with internal pull-up

[3] External interrupt input

### 3 Memory

MA903A1 is equipped with embedded 128KB flash memory and 1MB SRAM. The specification is listed as below.

Currently MA903A1 does not support the external memory due to performance compromises,

### 4 Serial Interfaces

MA903A1 support the common serial data interfaces, including GPIO, and UART. Their timing and specifications are addressed at the following sections.

#### 4.1 General-purpose I/O (GPIO)

The functions of GPIOs are summarized as below:

- Push-Pull output
- Open-Drain output
- Input only with high impedance (100K ~ 300Kohms)
- All inputs with Schmitt trigger
- I/O pin configured as interrupt source with edge/level setting
- Supports input 5V tolerance

#### 4.2 UART

##### Data Wake-Up

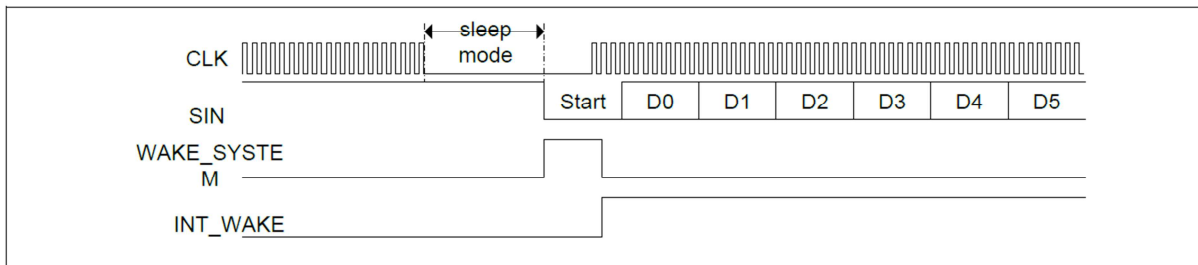

UART DATA Wake-Up



Figure7. UART Data Format

The features of UART interfaces are summarized as below:

- Two sets of UART controllers
- The UART0 and UART1 are built-in with a 16-byte TX\_FIFO and a 16-byte RX\_FIFO to reduce the number of interrupts presented to the CPU
- Baud rate is up to 460800 bps

## 5 How to Use MA903A1 to Design & Compliance with FCC requirements

The MA903A1 is a proprietary product design and manufactured by M2C (M<sup>2</sup>Communication Inc.) for integrated into wireless products manufactured by M2C for sub 1GHz ISM communication application. And the chapter will complete explain how to design MA903A1 on product.

### 5.1 50ohm RF Trace Calculation

The MA903A1 module has 50ohm impedance RF output pin (RFIO) to connect external antenna on carried board (or called Mother Board). RF trace on carried board is between RF output pin of MA903A1 and antenna on carried board and the trace must is 50ohm to obtain best RF performance. Also, 50ohm trace is recommended for PCB layout.

Engineer (or Developer) can use "PCB Transmission Line calculation tool" (example: Polar) to obtain value about RF layout information on PCB. Engineer just fill in value that FR4relative parameter in "PCB Transmission Line calculation tool", include PCB stack, substrate height, PCB dielectric, trace thickness....etc. 50ohm transmission line dimension can be got from the tool. Below figure10 show the PCB Transmission Line calculation tool.

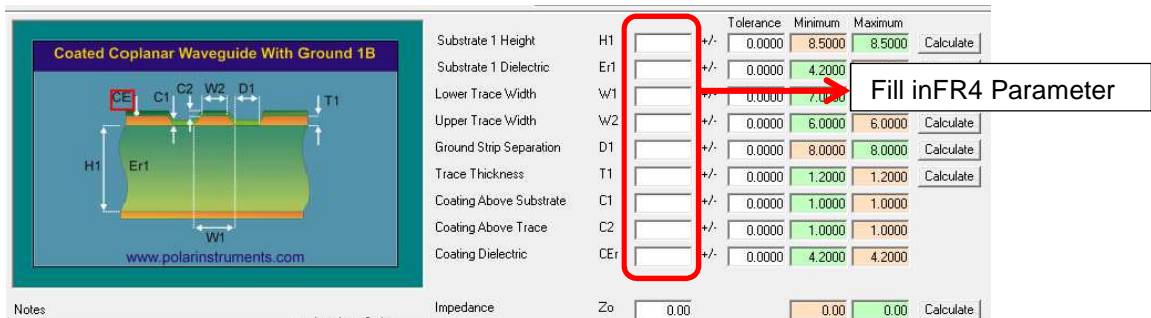

Figure8. Trace design for the PCB layout

Example: Use 2-layer FR4 PCB to design 50ohm trace

The figure 11 is 2-layers FR4 PCB parameter (PCB stack). The RF trace width and spacing that is between RF trace and ground plane and others value that is 50ohm design requires is show in figure 12.

PCB Stack Up					
Layer	Type		Thickness (mil)		DK
Top side solder mask			1.00	mils	3.8
L1	TOP	Differential & Signal	copper+plating	1.70	mils
core			14.00	mils	4
L4	Bottom	Differential & Signal	copper+plating	1.70	mils
Bottom side solder mask			1.00	mils	3.8
TOTAL			19.40	mils	
			0.49	mm	

Figure9. 2-layer FR4 PCB stack

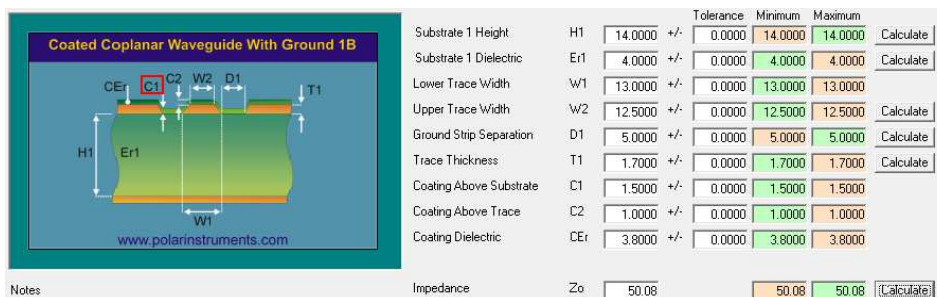

Figure10. 50ohm parameter of 2-layers FR4



## 5.2 PCB Design

MA903A1 provides 3 antennas (frequency: 902MHz~928MHz) for engineer chooses, one is PIFA type antenna; the other two are dipole antenna. About antenna manufacturer and model number can refer chapter 7.

When using dipole antenna on carried board, just need to make sure the impedance of RF trace is 50ohm, as below figure 11.



Figure11-1.Reversed SMA connector to connect dipole antenna

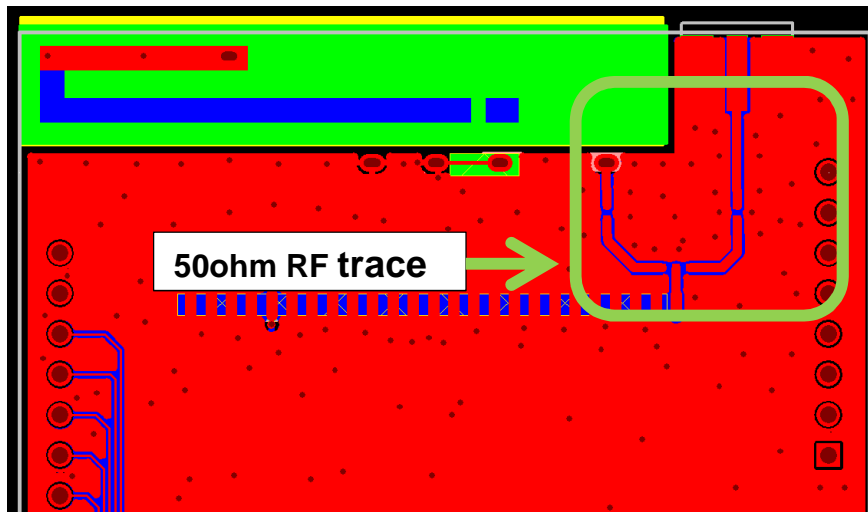

Figure11-2.Reversed SMA connector to connect dipole antenna

When using PIFA antenna in design PCB, need to make sure the impedance of RF trace is 50ohm. Structure of PIFA antenna can separate two parts. One is metal part that solder on PCB; the other is antenna trace on PCB. The different antenna trace length has different center frequency. Engineer can use network analyzer to fine-tune antenna trace length, so that antenna can work on required frequency (902MHz~928MHz). The trace dimension in figure14 is recommended to PCB layout.

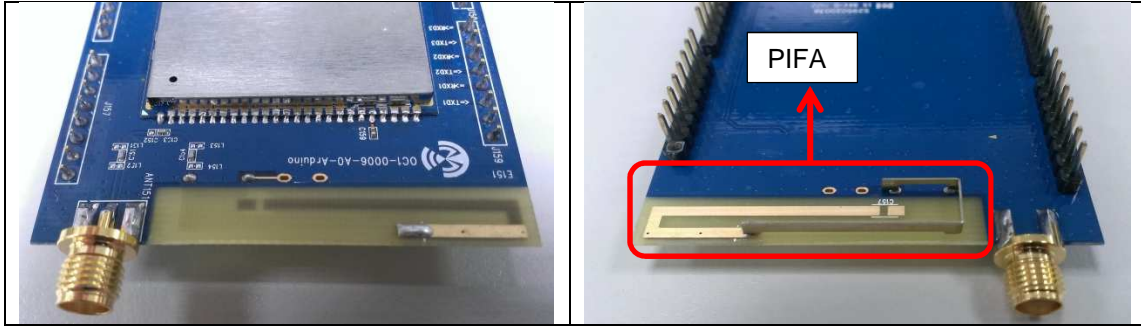

Figure12. PIFA antenna

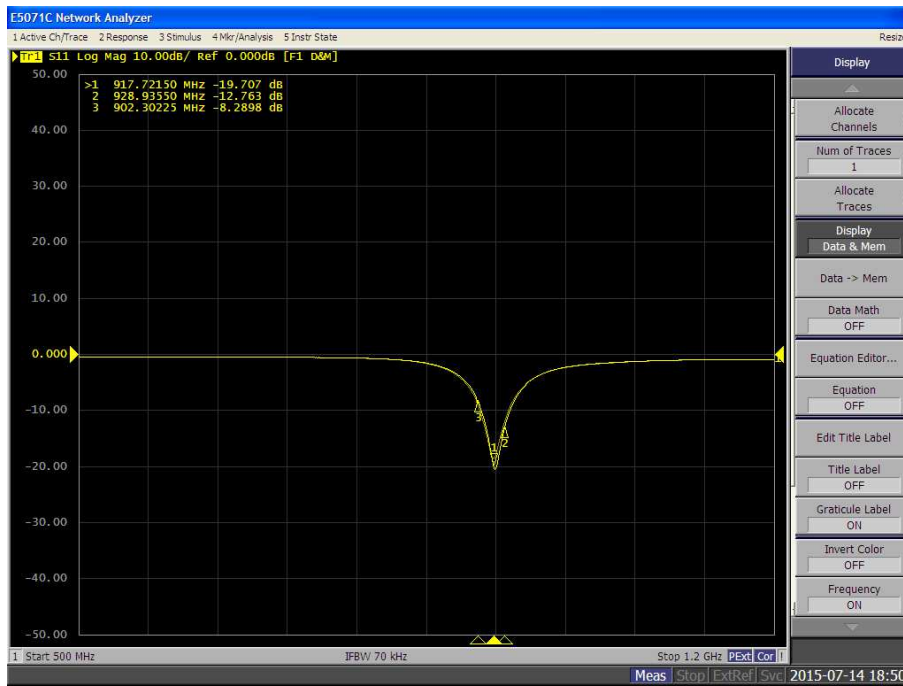

Figure13. Network analyzer to check frequency & return loss

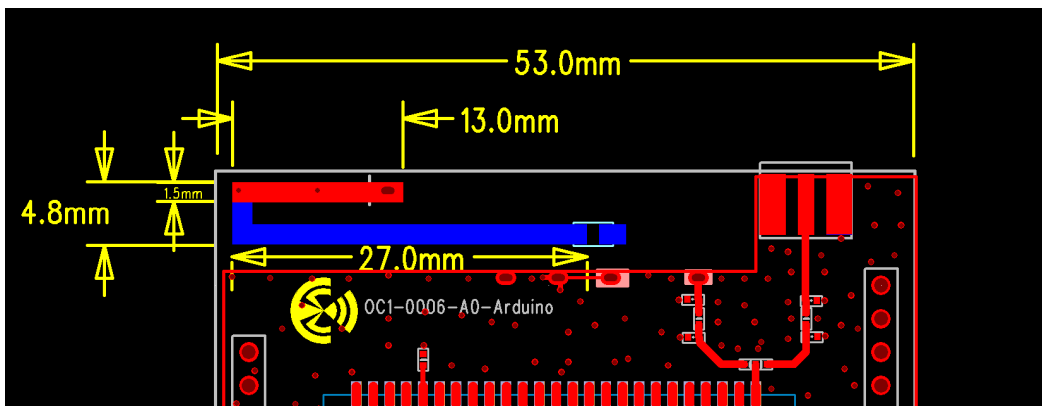

Figure14. PIFA antenna trace dimension



### 5.3 PCB Layout Recommend

- RF connector: Reversed SMA connector.
- RF trace length is less 80mm.

### 5.4 PCB Layout Guide

Some general rules of thumb for designing RF-related layouts for good RF performance are:

- Use as much continuous ground plane metallization as possible.
- Avoid the separation of the ground plane metallization at RF area.
- Use as many grounding vias (especially near to the GND pins) as possible to minimize series parasitic inductance between the ground pour and the GND pins.
- Use a series of GND vias (a so called “via curtain”) along the PCB edges and internal GND metal pouring edges. The maximum distance between the vias should be less than  $\lambda/10$  of the 10<sup>th</sup> harmonic. This is required to reduce the PCB radiation at higher harmonics caused by the fringing field of these edges.
- Avoid using long and/or thin transmission lines to connect the components. Otherwise, due to its distributed parasitic inductance some detuning effects can occur.
- Avoid using loops and long wires to obviate its resonances.
- Always ensure good VDD filtering by using some bypass capacitors (especially at the range of the operating frequency).

## 6 Available Antenna List

The MA903A1 RF module has 50ohm RF output pin (RFIO) to connect external 902MHz~928MHz antenna. The choice of antenna is limited to the antenna types the module has been tested with. Refer to Section 8 “Regulation Approval” for a list of tested and approved antenna types that may be used with the MA903A1 module.

A list of antenna approved for use with the module is provided as below table.

Antenna Type	Peak Gain	Model No.	Manufacturer
PIFA	0.3dBi	AN14-000079	RESILIENT
Dipole	1.42dBi	CWX-614XSAXX-999	JOYMAX
Dipole	2dBi	GWX-282XSABX-991	JOYMAX

Below antenna's pattern are measured and provide by vender.

- PIFA / AN14-000079

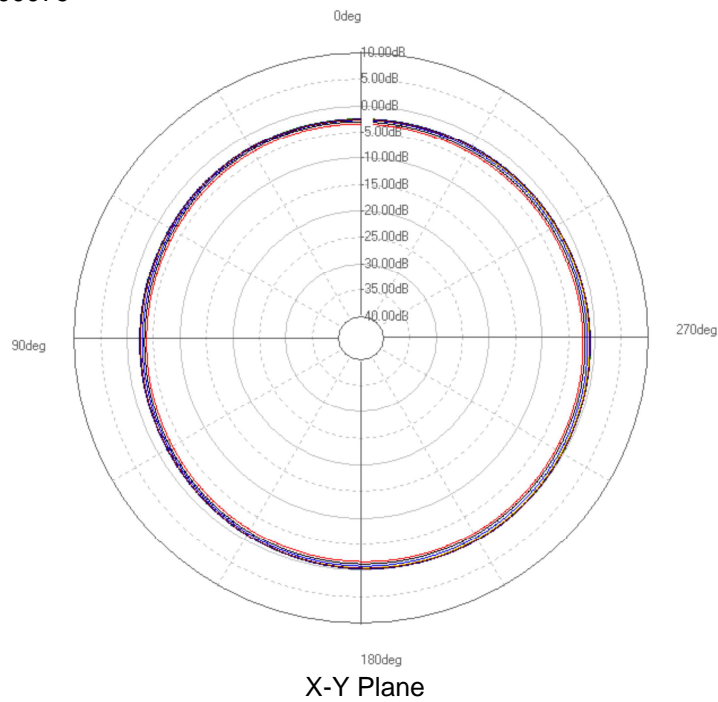



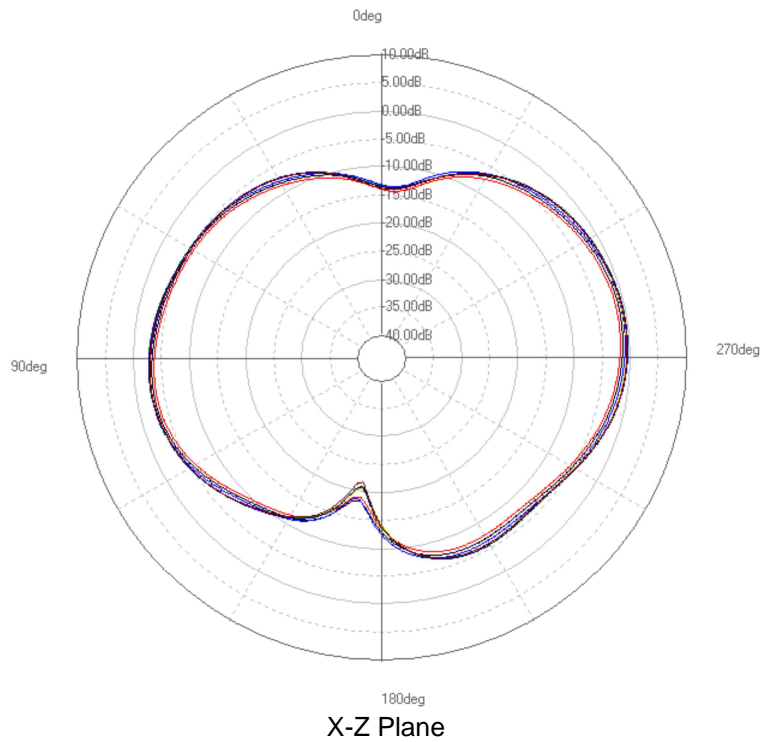
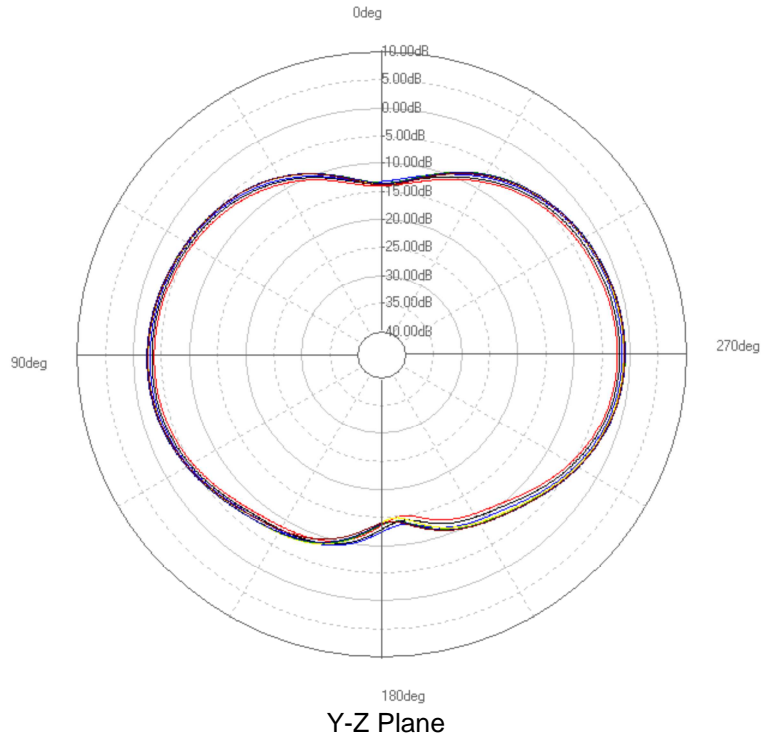





- Dipole / CWX-614XSAXX-999

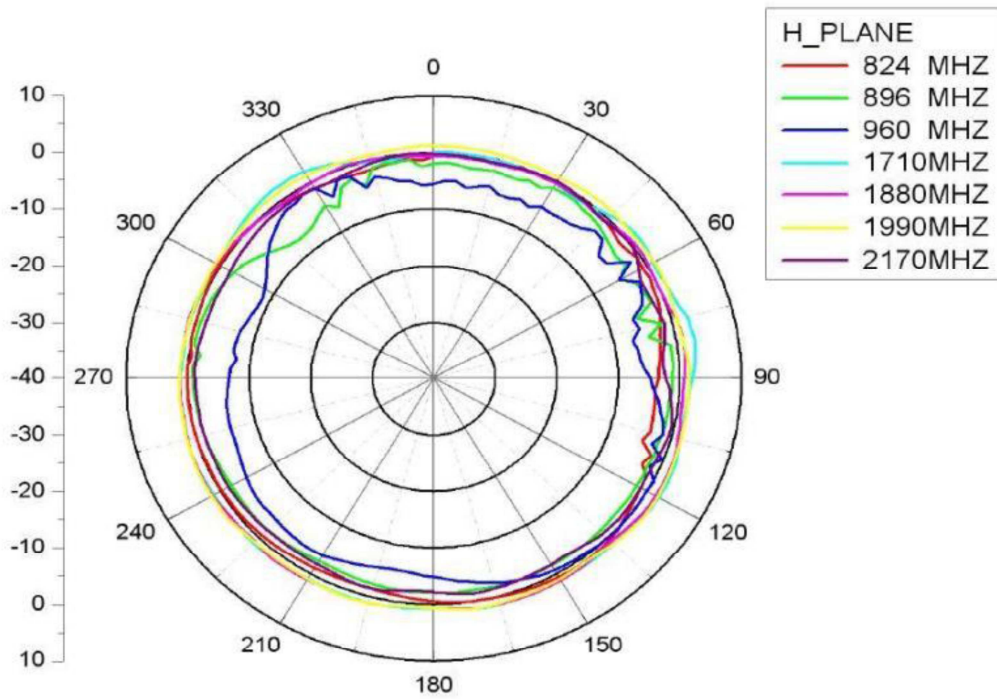
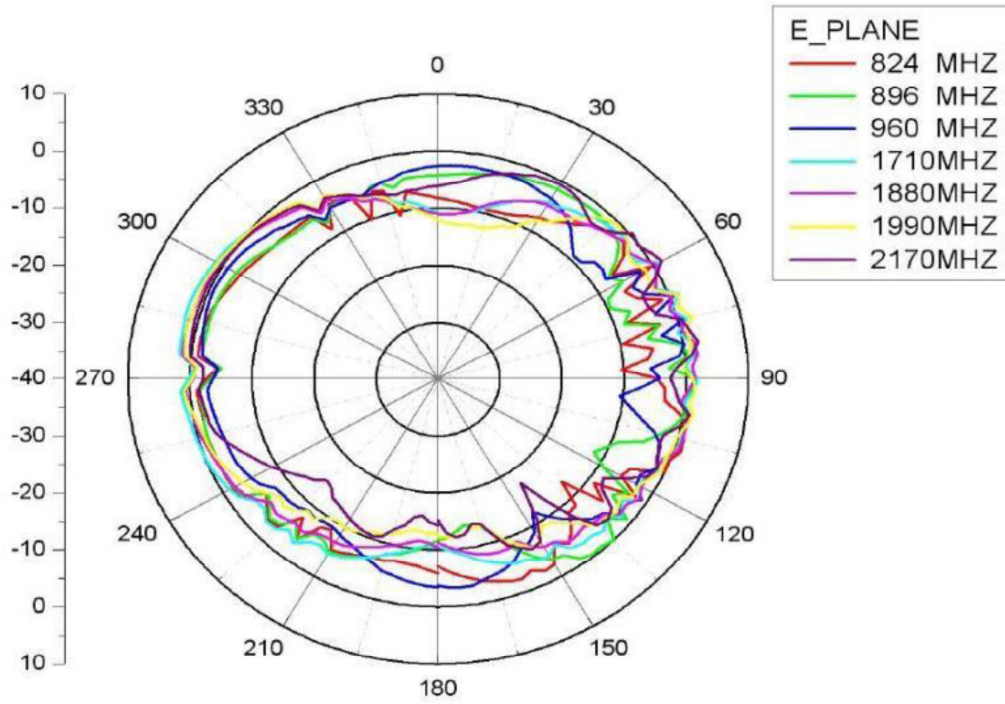



- Dipole / GWX-282XSABX-991

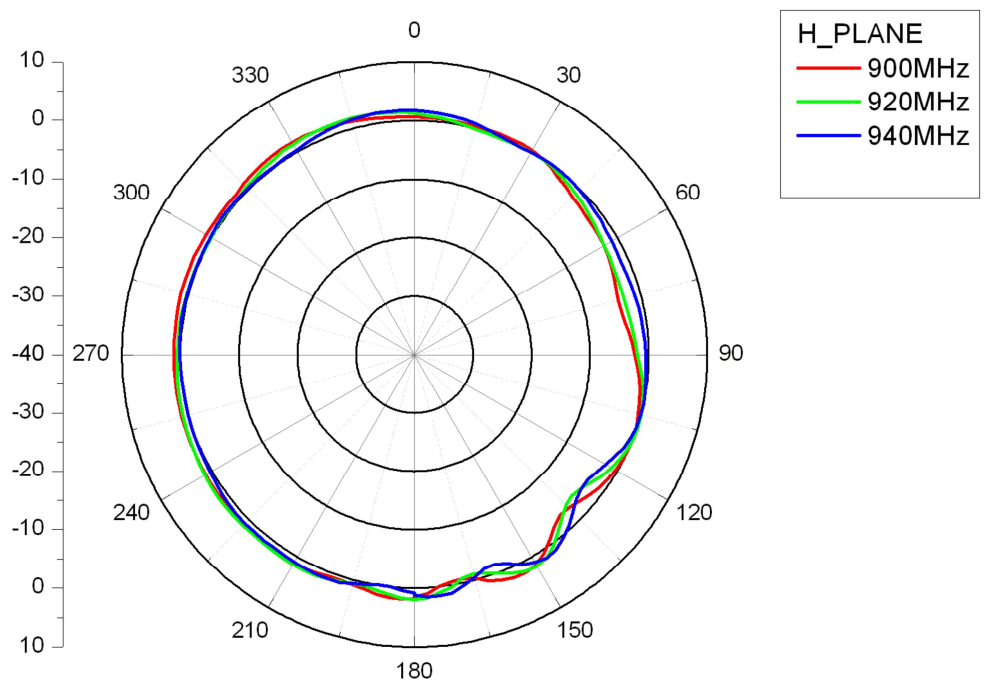
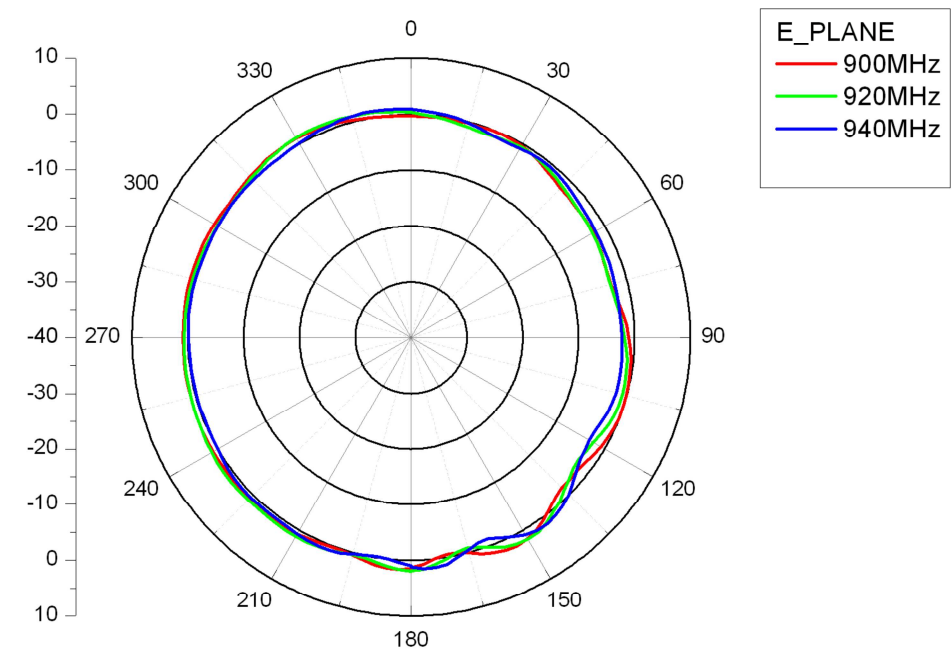

## 7 Regulation Approval

The MA903A1 module has received regulatory approvals for modular device in the United States. Modular approval allows the end user to place the MA903A1 module inside a finished product and not require regulatory testing for an intentional radiator (RF transmitter), provided no changes or modifications are made to the module circuitry. Changes or modifications could void the user's authority to operate the equipment. The end user must comply with all of the instructions provided by the grantee, which indicate installation and/or operating conditions necessary for compliance.

The MA903A1 has received Federal Communications Commission (FCC) CFR47 Telecommunications, Part 15 Subpart C "Intentional Radiators" 15.247 and modular approval in accordance with Part 15.212 modular Transmitter approval. The MA903A1 module can be integrated into a finished product without obtaining subsequent and separate FCC approvals for intentional radiation.

The MA903A1 module has been labeled with its own FCC ID number and if the FCC ID is not visible when the module is installed inside another device, then the outside of the finished product into which the module is installed must also display a label referring to the enclosed module. This exterior label can use wording as follows:

Contain Transmitter module FCC ID : **2AFXU-MA903A1**

This device complies with Part 15 of the FCC Rules. Operation is subject to the following two conditions:

(1) This device may not cause harmful interference, and (2) this device must accept any interference received ,including interference that may cause undesired operation.

## 8 Recommended PCB Footprint

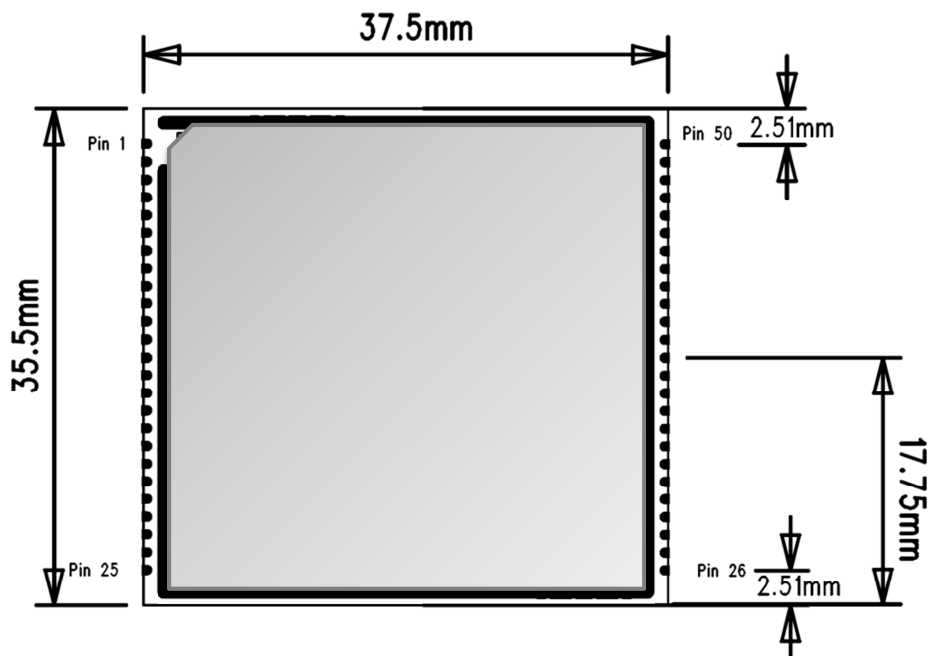

Figure15.Top View Outline Dimension

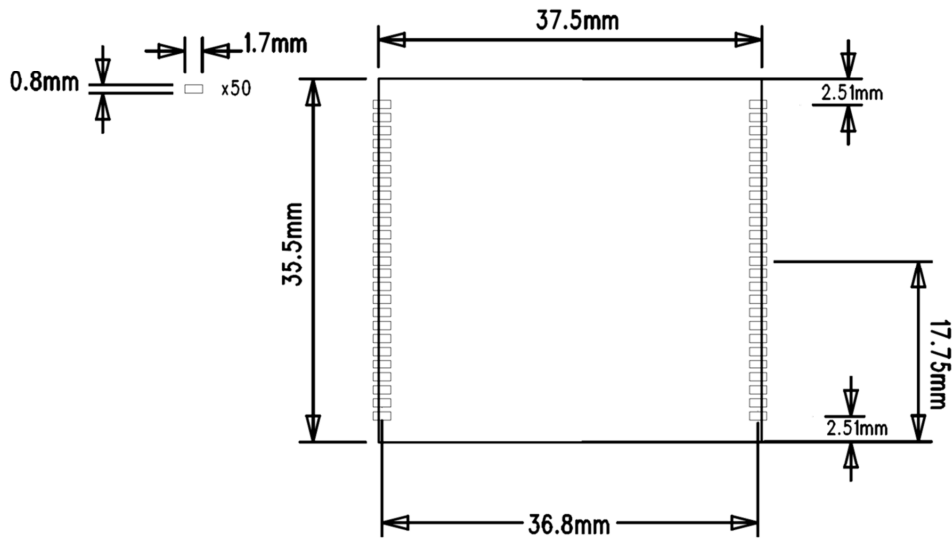

Figure16.Recommend PCB Footprint

## 9 Contact Information

### M<sup>2</sup>Communication Inc. (M2Comm)

4-3F, No.32, Gaotie 2nd Rd.,  
 Zhubei, Hsinchu County, Taiwan.  
 Tel: +886-3-657-8939  
 Fax: +886-3-657-6909  
 Email: sales@m2comm.com  
 www.m2comm-semi.com

## 10 Ordering Information

Ordering Part Number	Frequency Band	Product Description
MA903A1	903~927MHz	MA903A1 with 50-ohm output for external antenna

This document contains confidential information and is subject to the terms and conditions set forth in the Non-Disclosure Agreement between the Recipient Entity and M<sup>2</sup>Communication, Inc. (M2C) The information in this document is believed to be accurate in all respects at the time of publication but is subject to change without notice. M<sup>2</sup>Communication, Inc. assumes no responsibility for errors and omissions, and disclaims responsibility for any consequences resulting from the use of information included herein. Additionally, M<sup>2</sup>Communication, Inc. assumes no responsibility for the functioning of un-described features or parameters. M<sup>2</sup>Communication, Inc. reserves the right to make changes without further notice. M<sup>2</sup>Communication, Inc. makes no warranty, representation or guarantee regarding the suitability of its products for any particular purpose, nor does M<sup>2</sup>Communication, Inc. assume any liability arising out of the application or use of any product or circuit, and specifically disclaims any and all liability, including without limitation consequential or incidental damages. M<sup>2</sup>Communication, Inc. products are not designed, intended, or authorized for use in applications intended to support or sustain life, or for any other application in which the failure of the M<sup>2</sup>Communication, Inc. product could create a situation where personal injury or death may occur. Should Buyer purchase or use M<sup>2</sup>Communication, Inc. products for any such unintended or unauthorized application, Buyer shall indemnify and hold M<sup>2</sup>Communication, Inc. harmless against all claims and damages.



## FCC Statement:

### Federal Communication Commission Interference Statement

This equipment has been tested and found to comply with the limits for a Class B digital device, pursuant to Part 15 of the FCC Rules. These limits are designed to provide reasonable protection against harmful interference in a residential installation. This equipment generates, uses and can radiate radio frequency energy and, if not installed and used in accordance with the instructions, may cause harmful interference to radio communications. However, there is no guarantee that interference will not occur in a particular installation. If this equipment does cause harmful interference to radio or television reception, which can be determined by turning the equipment off and on, the user is encouraged to try to correct the interference by one of the following measures:

- Reorient or relocate the receiving antenna.
- Increase the separation between the equipment and receiver.
- Connect the equipment into an outlet on a circuit different from that to which the receiver is connected.
- Consult the dealer or an experienced radio/TV technician for help.

FCC Caution: Any changes or modifications not expressly approved by the party responsible for compliance could void the user's authority to operate this equipment.

This device complies with Part 15 of the FCC Rules. Operation is subject to the following two conditions: (1) This device may not cause harmful interference, and (2) this device must accept any interference received, including interference that may cause undesired operation.

This device and its antenna(s) must not be co-located with any other transmitters except in accordance with FCC multi-transmitter product procedures.

Referring to the multi-transmitter policy, multiple-transmitter(s) and module(s) can be operated simultaneously without C2P.

### IMPORTANT NOTE:

#### FCC Radiation Exposure Statement:

This equipment complies with FCC radiation exposure limits set forth for an uncontrolled environment. This equipment should be installed and operated with minimum distance 20 cm between the radiator & your body.

### IMPORTANT NOTE:

This module is intended for OEM integrator. The OEM integrator is responsible for the compliance to all the rules that apply to the product into which this certified RF module is integrated.

Additional testing and certification may be necessary when multiple modules are used.

20 cm minimum distance has to be able to be maintained between the antenna and the users for the host this module is integrated into. Under such configuration, the FCC radiation exposure limits set forth for an population/uncontrolled environment can be satisfied.

Any changes or modifications not expressly approved by the manufacturer could void the user's authority to operate this equipment.

### USERS MANUAL OF THE END PRODUCT:

In the users manual of the end product, the end user has to be informed to keep at least 20 cm separation with the antenna while this end product is installed and operated. The end user has to be informed that the FCC radio-frequency exposure guidelines for an uncontrolled environment can be satisfied. The end user has to also be informed that any changes or modifications not expressly approved by the manufacturer could void the user's authority to operate this equipment. If the size of the end product is smaller than 8x10cm, then additional FCC part 15.19 statement is required to be available in the users manual: This device complies with Part 15 of FCC rules. Operation is subject to

the following two conditions: (1) this device may not cause harmful interference and (2) this device must accept any interference received, including interference that may cause undesired operation.

**LABEL OF THE END PRODUCT:**

The final end product must be labeled in a visible area with the following " Contains TX FCC ID: 2AFXU-MA903A1 ". If the size of the end product is larger than 8x10cm, then the following FCC part 15.19 statement has to also be available on the label: This device complies with Part 15 of FCC rules. Operation is subject to the following two conditions: (1) this device may not cause harmful interference and (2) this device must accept any interference received, including interference that may cause undesired operation.