



SPORTON International Inc.

No. 52, Hwa Ya 1st Rd., Hwa Ya Technology Park, Kwei-Shan Hsiang, Tao Yuan Hsien, Taiwan, R.O.C.
Ph: 886-3-327-3456 / FAX: 886-3-327-0973 / www.sporton.com.tw

FCC RADIO TEST REPORT

Applicant's company	M2Communication Inc.
Applicant Address	4F-3, No.32, Gaotie 2nd Rd., Zhubei City, Hsinchu County 302 Taiwan (R.O.C.)
FCC ID	2AFXU-MA903A1
Manufacturer's company	Might Electronic CO. LTD., Taiwan
Manufacturer Address	No. 40, 2nd Neighborhood, Yuanshan Vil., Xinfeng Township, Hsinchu County 304, Taiwan, R.O.C.

Product Name	Wireless AP Module_9 series
Brand Name	M2Communication Inc.
Model No.	MA903A1
Test Rule	47 CFR FCC Part 15 Subpart C § 15.247
Test Freq. Range	902 ~ 928 MHz
Received Date	Aug. 28, 2015
Final Test Date	Sep. 24, 2015
Submission Type	Original Equipment

Statement

The test result in this report refers exclusively to the presented test model / sample.

Without written approval of SPORTON International Inc., the test report shall not be reproduced except in full.

The measurements and test results shown in this test report were made in accordance with the procedures and found in compliance with the limit given in **ANSI C63.10-2013, 47 CFR FCC Part 15 Subpart C** and **KDB558074 D01 v03r03**.

The test equipment used to perform the test is calibrated and traceable to NML/ROC.



Table of Contents

1. VERIFICATION OF COMPLIANCE	1
2. SUMMARY OF THE TEST RESULT	2
3. GENERAL INFORMATION	3
3.1. Product Details.....	3
3.2. Accessories.....	3
3.3. Table for Filed Antenna.....	3
3.4. Table for Carrier Frequencies	3
3.5. Table for Test Modes	4
3.6. Table for Testing Locations.....	5
3.7. Table for Supporting Units	5
3.8. Table for Parameters of Test Software Setting	5
3.9. EUT Operation during Test	6
3.10. Duty Cycle.....	6
3.11. Test Configurations	7
4. TEST RESULT	9
4.1. Maximum Conducted Output Power Measurement.....	9
4.2. Power Spectral Density Measurement	11
4.3. 6dB Spectrum Bandwidth Measurement	16
4.4. Radiated Emissions Measurement	22
4.5. Band Edge Emissions Measurement	34
4.6. Antenna Requirements	44
5. LIST OF MEASURING EQUIPMENTS	45
6. MEASUREMENT UNCERTAINTY	46
APPENDIX A. TEST PHOTOS	A1 ~ A8



History of This Test Report

REPORT NO.	VERSION	DESCRIPTION	ISSUED DATE
FR582816	Rev. 01	Initial issue of report	Oct. 02, 2015



1. VERIFICATION OF COMPLIANCE

Product Name : Wireless AP Module_9 series
Brand Name : M2Communication Inc.
Model No. : MA903A1
Applicant : M2Communication Inc.
Test Rule Part(s) : 47 CFR FCC Part 15 Subpart C § 15.247

Sporton International as requested by the applicant to evaluate the EMC performance of the product sample received on Aug. 28, 2015 would like to declare that the tested sample has been evaluated and found to be in compliance with the tested rule parts. The data recorded as well as the test configuration specified is true and accurate for showing the sample's EMC nature.

A handwritten signature in blue ink that reads "Sam Chen". The signature is written over a horizontal line.

Reviewed By:

Sam Chen

SPORTON INTERNATIONAL INC.

2. SUMMARY OF THE TEST RESULT

Applied Standard: 47 CFR FCC Part 15 Subpart C				
Part	Rule Section	Description of Test	Result	Under Limit
-	15.207	AC Power Line Conducted Emissions	Complies	Note
4.1	15.247(b)(3)	Maximum Conducted Output Power	Complies	18.72 dB
4.2	15.247(e)	Power Spectral Density	Complies	2.65 dB
4.3	15.247(a)(2)	6dB Spectrum Bandwidth	Complies	-
4.4	15.247(d)	Radiated Emissions	Complies	5.46 dB
4.5	15.247(d)	Band Edge Emissions	Complies	-
4.6	15.203	Antenna Requirements	Complies	-

Note: It was supplied power by battery for EUT; it's not necessary to apply to AC Power Port Conducted emission test.

3. GENERAL INFORMATION

3.1. Product Details

Items	Description
Power Type	From battery (3.0V)
Modulation	2FSK
Frequency Range	902 ~ 928 MHz
Operating Range	903 ~ 927 MHz
Channel Number	8
Channel Space	3 MHz
Channel Band Width (99%)	567.29 kHz
Maximum Conducted Output Power	11.28 dBm
Carrier Frequencies	Please refer to section 3.4
Antenna	Please refer to section 3.3

3.2. Accessories

N/A

3.3. Table for Filed Antenna

Ant.	Brand Holder	Part No.	Antenna Type	Connector	Gain (dBi)
1	Resilient Technology Co., Ltd.	AN14-000079	PIFA Antenna	N/A	0.30
Ant.	Brand Holder	Model No.	Antenna Type	Connector	Gain (dBi)
2	JOYMAX ELECTRONICS CO.,LTD	GWX-282XSABX-991	Dipole Antenna	Reversed SMA	2.00
3	JOYMAX ELECTRONICS CO.,LTD	CWX-614XSAXX-999	Dipole Antenna	Reversed SMA	1.42

Note: Ant. 2 and Ant. 3 are the same type antenna, and Ant. 2's gain is higher than that of Ant. 3. Thus, Ant. 2 was tested and recorded in this report.

3.4. Table for Carrier Frequencies

Frequency Band	Channel No.	Frequency	Channel No.	Frequency
902 ~ 928 MHz	1	903 MHz	5	918 MHz
	2	906 MHz	6	921 MHz
	3	909 MHz	7	924 MHz
	4	915 MHz	8	927 MHz

3.5. Table for Test Modes

Preliminary tests were performed in different data rate to find the worst radiated emission. The data rate shown in the table below is the worst-case rate with respect to the specific test item. Investigation has been done on all the possible configurations for searching the worst cases. The following table is a list of the test modes shown in this test report.

For Ant. 1 (PIFA Ant.)

Test Items	Mode	Channel	Ant.
Radiated Emissions 9kHz~1GHz	Normal Link	-	-
Radiated Emissions 1GHz~10 th Harmonic	2FSK	1/4/8	1
Band Edge Emissions	2FSK	1/4/8	1

For Ant. 2 (Dipole Ant.)

Test Items	Mode	Channel	Ant.
Maximum Conducted Output Power Power Spectral Density 6dB Spectrum Bandwidth	2FSK	1/4/8	2
Radiated Emissions 9kHz~1GHz	Normal Link	-	-
Radiated Emissions 1GHz~10 th Harmonic	2FSK	1/4/8	2
Band Edge Emissions	2FSK	1/4/8	2

The following test modes were performed for all tests:

For Other Tests:

Only the highest gain antenna (Dipole Ant.) was selected to test and record in this report.

Mode 1: CTX / Ant. 2 (Dipole)

For Radiated Emission test<Below 1GHz>:

Mode 1. Normal Link - EUT in Z axis with Ant. 1 (PIFA Ant.)

Mode 2. Normal Link - EUT in Z axis with Ant. 2 (Dipole Ant.)

Mode 1 is the worst case, so it was selected to record in this test report.

For Radiated Emission test<Above 1GHz>:

The EUT was performed at X axis, Y axis and Z axis position for Radiated emission above 1GHz test, and the worst case was found at X axis. So the measurement will follow this same test configuration.

Mode 1. CTX-EUT in X axis with Ant. 1 (PIFA Ant.)

Mode 2. CTX-EUT in X axis with Ant. 2 (Dipole Ant.)

3.6. Table for Testing Locations

Test Site Location					
Address:	No.8, Lane 724, Bo-ai St., Jhubei City, Hsinchu County 302, Taiwan, R.O.C.				
TEL:	886-3-656-9065				
FAX:	886-3-656-9085				
Test Site No.	Site Category	Location	FCC Reg. No.	IC File No.	VCCI Reg. No
03CH01-CB	SAC	Hsin Chu	262045	IC 4086D	-
TH01-CB	OVEN Room	Hsin Chu	-	-	-

Open Area Test Site (OATS); Semi Anechoic Chamber (SAC).

3.7. Table for Supporting Units

For Test Site No: 03CH01-CB (Below 1GHz)

Support Unit	Brand	Model	FCC ID
Notebook	DELL	E4300	DoC
ESL Access Point_9 series	M2Communication Inc.	AP903B1	DoC
Test fixture	M2Communication Inc.	OC1-0006-A0	N/A

For Test Site No: 03CH01-CB (Above1GHz) and TH01-CB

Support Unit	Brand	Model	FCC ID
Notebook	DELL	E4300	DoC
Test fixture	M2Communication Inc.	OC1-0006-A0	N/A

3.8. Table for Parameters of Test Software Setting

During testing, Channel & Power Controlling Software provided by the customer was used to control the operating channel as well as the output power level. The RF output power selection is for the setting of RF output power expected by the customer and is going to be fixed on the firmware of the final end product.

Power Parameters

<For Ant. 2 (Dipole)>:

Test Software Version	Tera Tem Version 4.75		
Frequency	903 MHz	915 MHz	927 MHz
2FSK	11	11	11

3.9. EUT Operation during Test

The EUT was programmed to be in continuously transmitting mode.

3.10. Duty Cycle

On Time (ms)	On+Off Time (ms)	Duty Cycle (%)	Duty Factor (dB)	1/T Minimum VBW (kHz)
1.000	1.000	100.00%	0.00	0.01

3.11. Test Configurations

3.11.1. Radiation Emissions Test Configuration

Test Configuration: 30MHz~1GHz

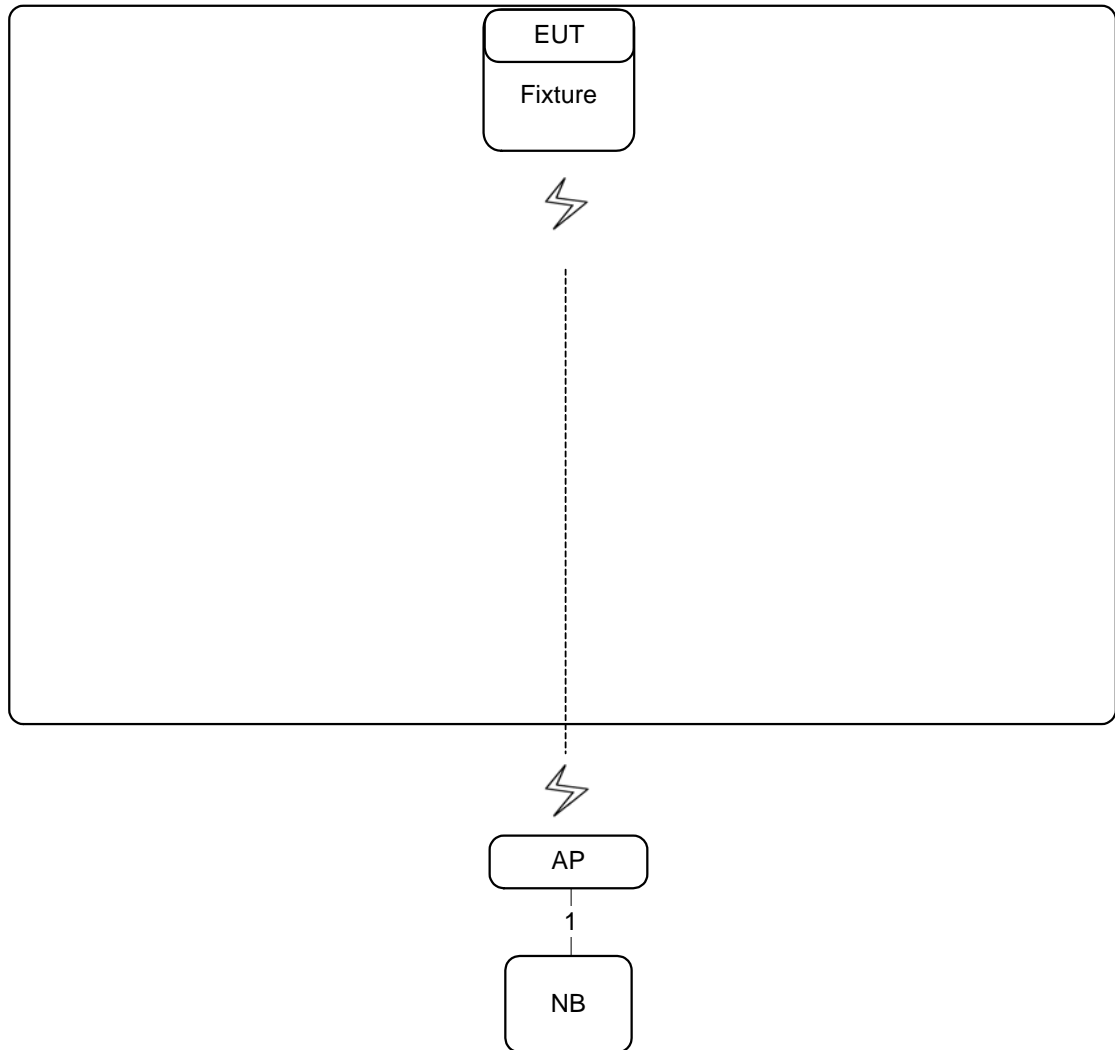

Item	Connection	Shielded	Length
1	RJ-45 cable	No	1m

Test Configuration: Above 1GHz

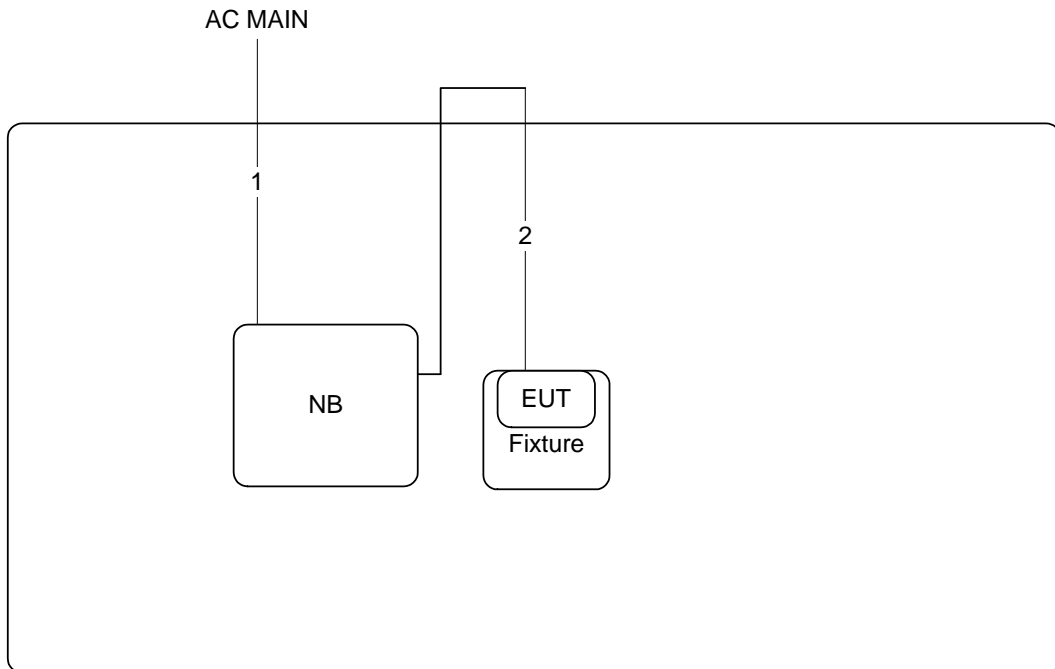

Item	Connection	Shielded	Length
1	Power cable	No	2.6m
2	USB cable	Yes	2m

4. TEST RESULT

4.1. Maximum Conducted Output Power Measurement

4.1.1. Limit

The limit for output power is 30dBm.

4.1.2. Measuring Instruments and Setting

Please refer to section 5 of equipments list in this report. The following table is the setting of the power meter.

Power Meter Parameter	Setting
Bandwidth	50MHz bandwidth is greater than the EUT emission bandwidth
Detector	Average

4.1.3. Test Procedures

1. Test procedures refer KDB558074 D01 v03r03 section 9.2.3.2 Measurement using a power meter (PM).
2. This procedure provides an alternative for determining the RMS output power using a broadband RF average power meter with a thermocouple detector.

4.1.4. Test Setup Layout

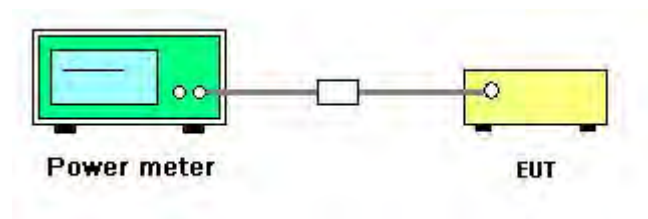

4.1.5. Test Deviation

There is no deviation with the original standard.

4.1.6. EUT Operation during Test

The EUT was programmed to be in continuously transmitting mode.

4.1.7. Test Result of Maximum Conducted Output Power

Temperature	28°C	Humidity	64%
Test Engineer	Satoshi Yang	Configurations	2FSK

Channel	Frequency	Conducted Power (dBm)	Max. Limit (dBm)	Result
1	903 MHz	11.26	30.00	Complies
4	915 MHz	11.28	30.00	Complies
8	927 MHz	11.11	30.00	Complies

4.2. Power Spectral Density Measurement

4.2.1. Limit

For digitally modulated systems, the power spectral density conducted from the intentional radiator to the antenna shall not be greater than 8 dBm in any 3 kHz band during any time interval of continuous transmission.

4.2.2. Measuring Instruments and Setting

Please refer to section 5 of equipments list in this report. The following table is the setting of the spectrum analyzer.

Spectrum Parameter	Setting
Attenuation	Auto
Span Frequency	Set the span to 1.5 times the DTS channel bandwidth.
RBW	$3 \text{ kHz} \leq \text{RBW} \leq 100\text{kHz}$
VBW	$\geq 3 \times \text{RBW}$
Detector	Peak
Trace	Max Hold
Sweep Time	Auto couple

4.2.3. Test Procedures

1. Test was performed in accordance with KDB558074 D01 v03r03 for Performing Compliance Measurements on Digital Transmission Systems (DTS) - section 10.2 Method PKPSD (peak PSD).
2. Use this procedure when the maximum conducted output power in the fundamental emission is used to demonstrate compliance. The EUT must be configured to transmit continuously at full power over the measurement duration.
3. Ensure that the number of measurement points in the sweep $\geq 2 \times \text{span/RBW}$ (use of a greater number of measurement points than this minimum requirement is recommended).
4. Use the peak marker function to determine the maximum level in any 3 kHz band segment within the fundamental EBW.
5. The resulting PSD level must be $\leq 8 \text{ dBm}$.

4.2.4. Test Setup Layout

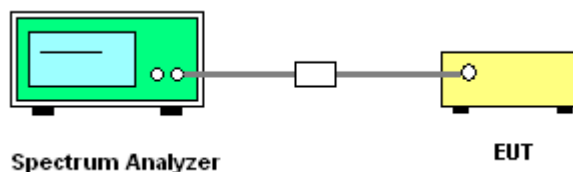

4.2.5. Test Deviation

There is no deviation with the original standard.

4.2.6. EUT Operation during Test

The EUT was programmed to be in continuously transmitting mode.

4.2.7. Test Result of Power Spectral Density

Temperature	28°C	Humidity	64%
Test Engineer	Satoshi Yang	Configurations	2FSK

Channel	Frequency	Power Density (dBm/3kHz)	Max. Limit (dBm/3kHz)	Result
1	903 MHz	5.35	8.00	Complies
4	915 MHz	5.06	8.00	Complies
8	927 MHz	4.34	8.00	Complies

Power Density Plot on Configuration 2FSK / 903 MHz

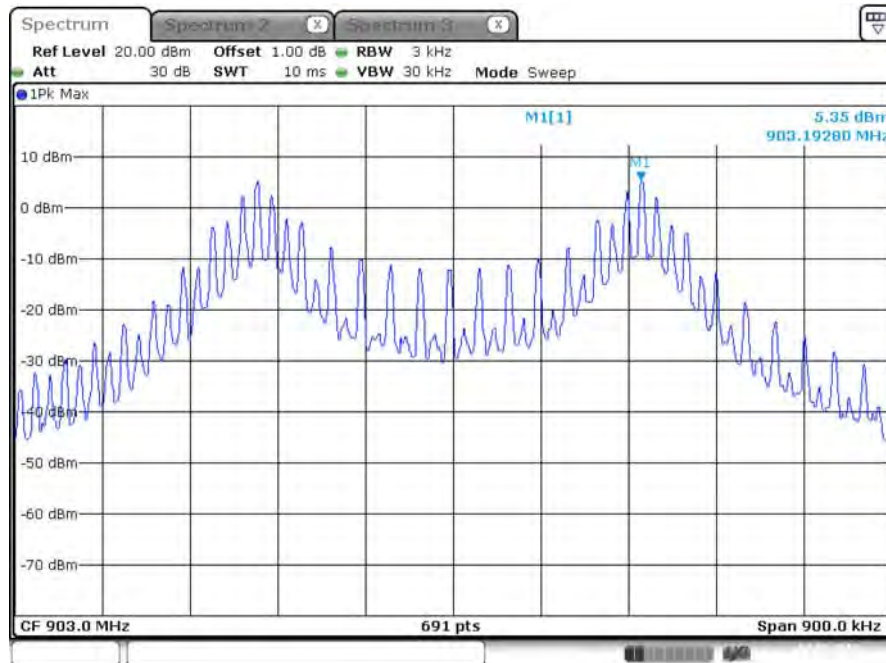

Date: 4 SEP 2015 18:04:13

Power Density Plot on Configuration 2FSK / 915 MHz

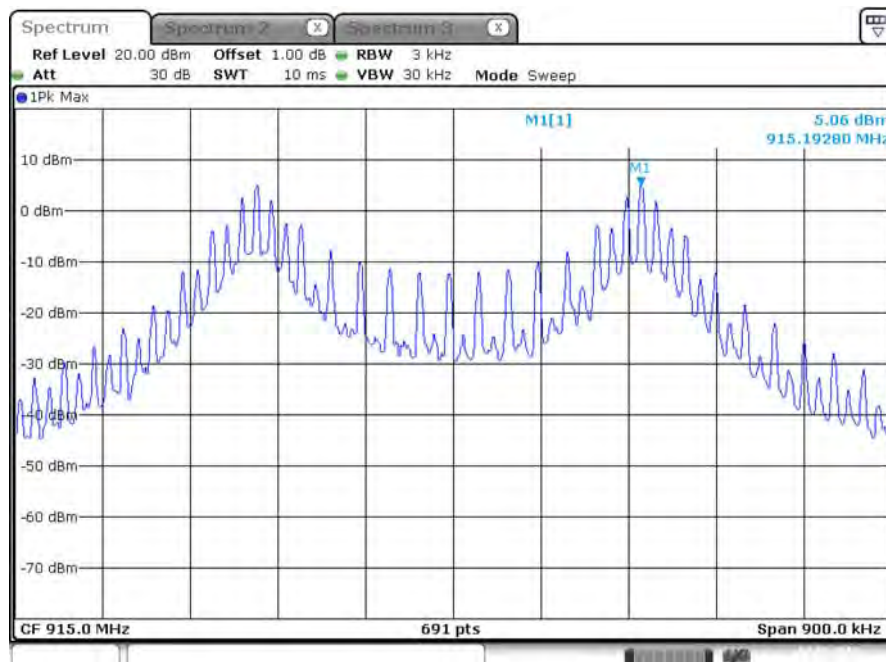

Date: 4 SEP 2015 18:05:10

Power Density Plot on Configuration 2FSK / 927 MHz

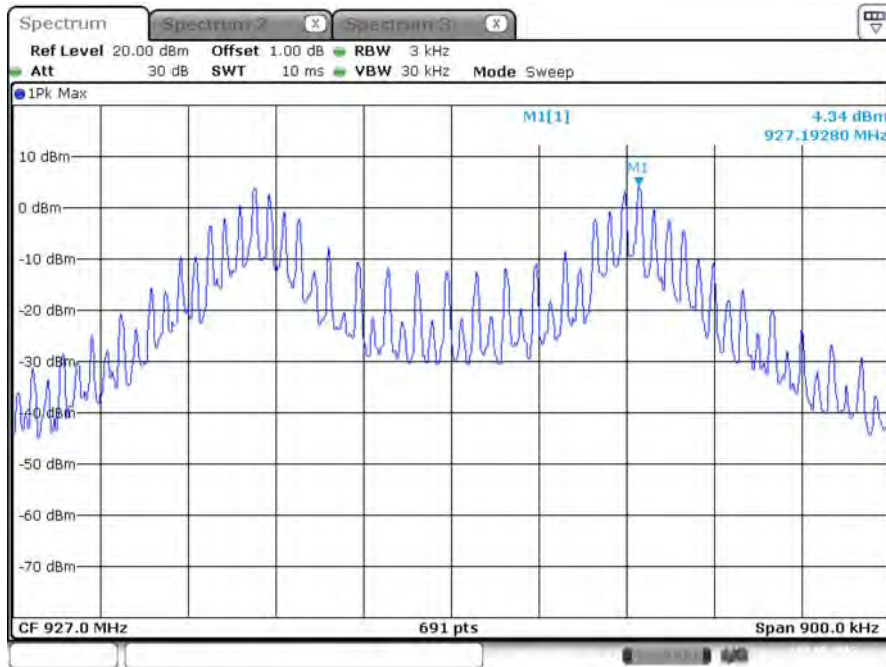

4.3. 6dB Spectrum Bandwidth Measurement

4.3.1. Limit

For digital modulation systems, the minimum 6dB bandwidth shall be at least 500 kHz.

4.3.2. Measuring Instruments and Setting

Please refer to section 5 of equipments list in this report. The following table is the setting of the spectrum analyzer.

6dB Spectrum Bandwidth	
Spectrum Parameters	Setting
Attenuation	Auto
Span Frequency	> 6dB Bandwidth
RBW	100kHz
VBW	$\geq 3 \times \text{RBW}$
Detector	Peak
Trace	Max Hold
Sweep Time	Auto
99% Occupied Bandwidth	
Spectrum Parameters	Setting
Span	1.5 times to 5.0 times the OBW
RBW	1 % to 5 % of the OBW
VBW	$\geq 3 \times \text{RBW}$
Detector	Peak
Trace	Max Hold

4.3.3. Test Procedures

For Radiated 6dB Bandwidth Measurement:

1. The transmitter was radiated to the spectrum analyzer in peak hold mode.
2. Test was performed in accordance with KDB558074 D01 v03r03 for Performing Compliance Measurements on Digital Transmission Systems (DTS) - section 8.0 DTS bandwidth = > 8.1 Option 1.
3. Measured the spectrum width with power higher than 6dB below carrier.

4.3.4. Test Setup Layout

For Radiated 6dB Bandwidth Measurement:

This test setup layout is the same as that shown in section 4.4.4.

4.3.5. Test Deviation

There is no deviation with the original standard.

4.3.6. EUT Operation during Test

The EUT was programmed to be in continuously transmitting mode.

4.3.7. Test Result of 6dB Spectrum Bandwidth

Temperature	28°C	Humidity	64%
Test Engineer	Satoshi Yang	Configurations	2FSK

Channel	Frequency	6dB Bandwidth (kHz)	99% Occupied Bandwidth (kHz)	Min. Limit (kHz)	Test Result
1	903 MHz	609.80	528.80	500	Complies
4	915 MHz	607.80	559.19	500	Complies
8	927 MHz	628.10	567.29	500	Complies

6 dB Bandwidth Plot on Configuration 2FSK / 903 MHz

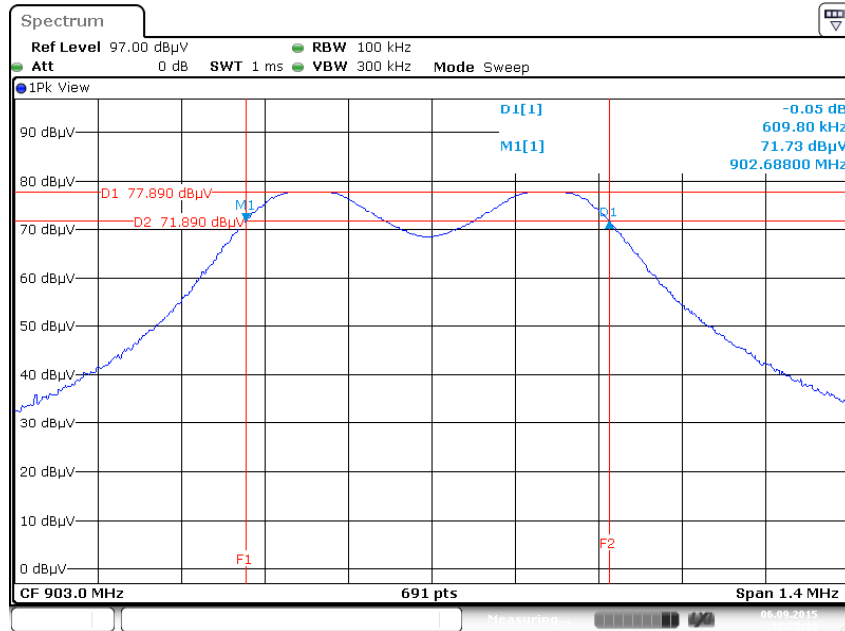

Date: 6 SEP 2015 17:29:19

99% Occupied Bandwidth Plot on Configuration 2FSK / 903 MHz

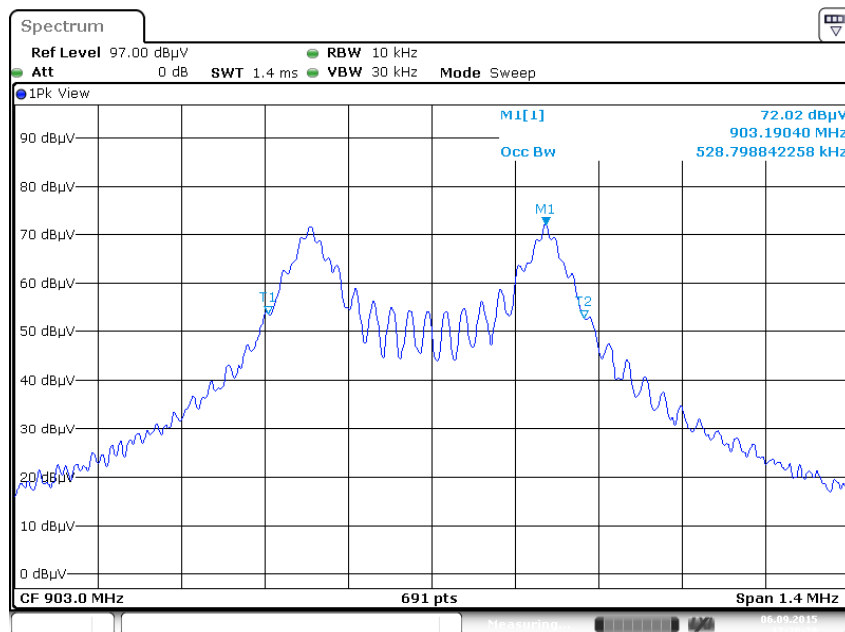

Date: 6 SEP 2015 17:38:28

6 dB Bandwidth Plot on Configuration 2FSK / 915 MHz

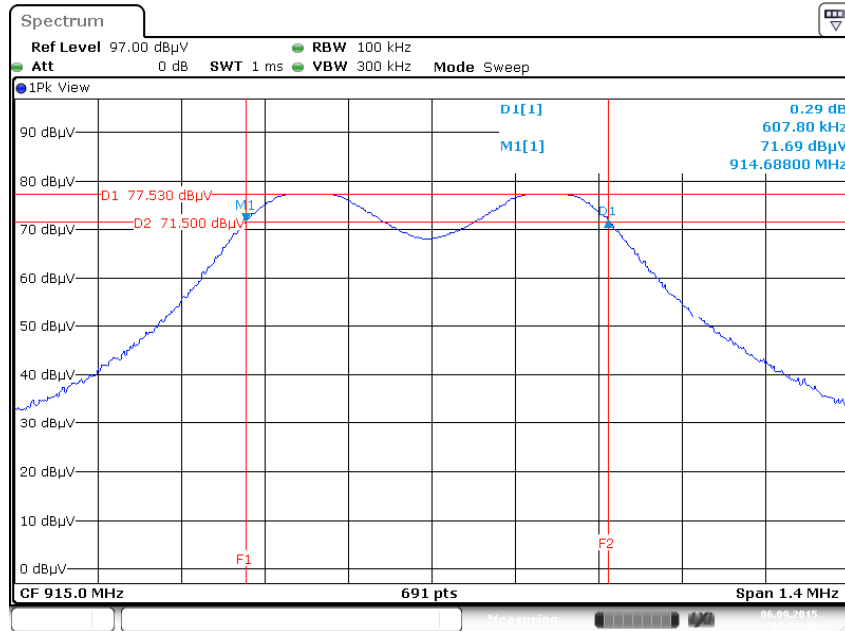

99% Occupied Bandwidth Plot on Configuration 2FSK / 915 MHz

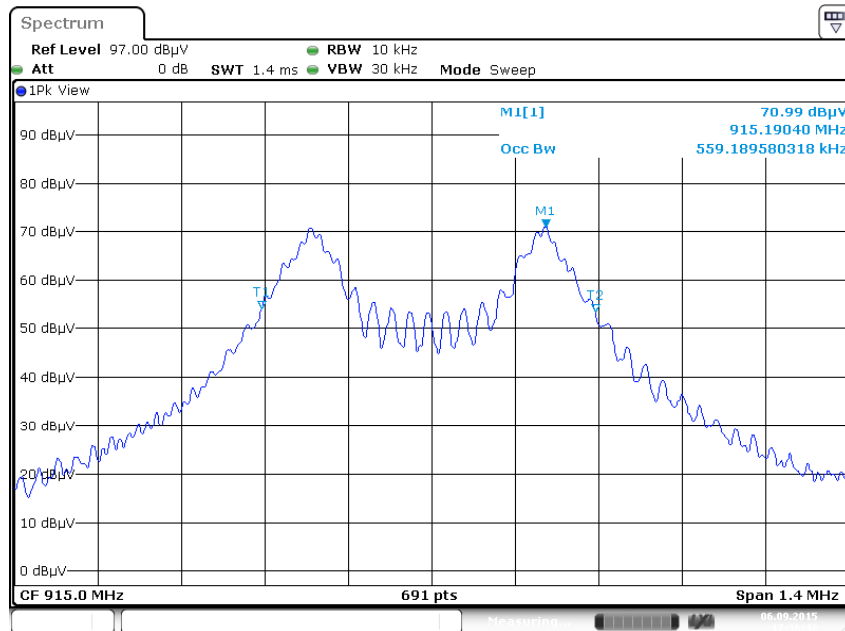

6 dB Bandwidth Plot on Configuration 2FSK / 927 MHz

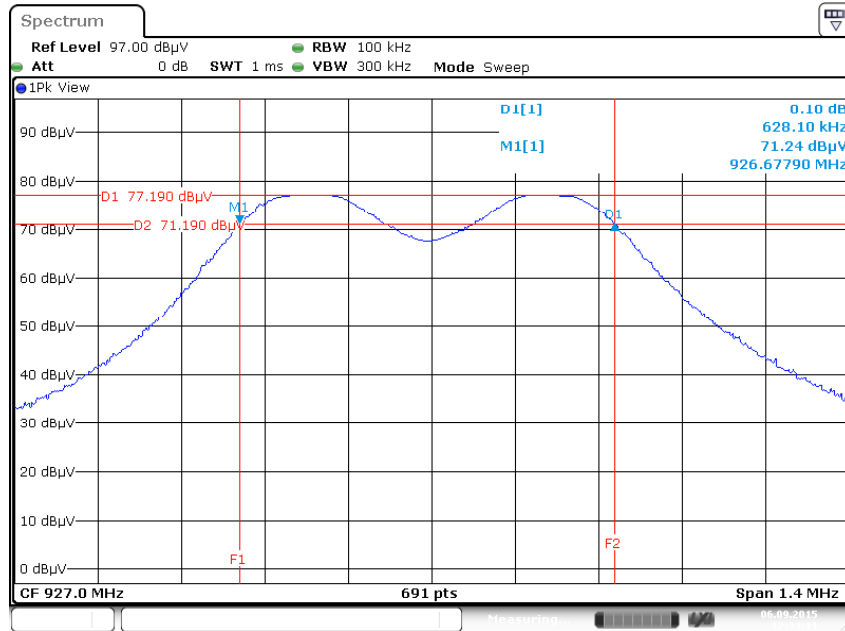

99% Occupied Bandwidth Plot on Configuration 2FSK / 927 MHz

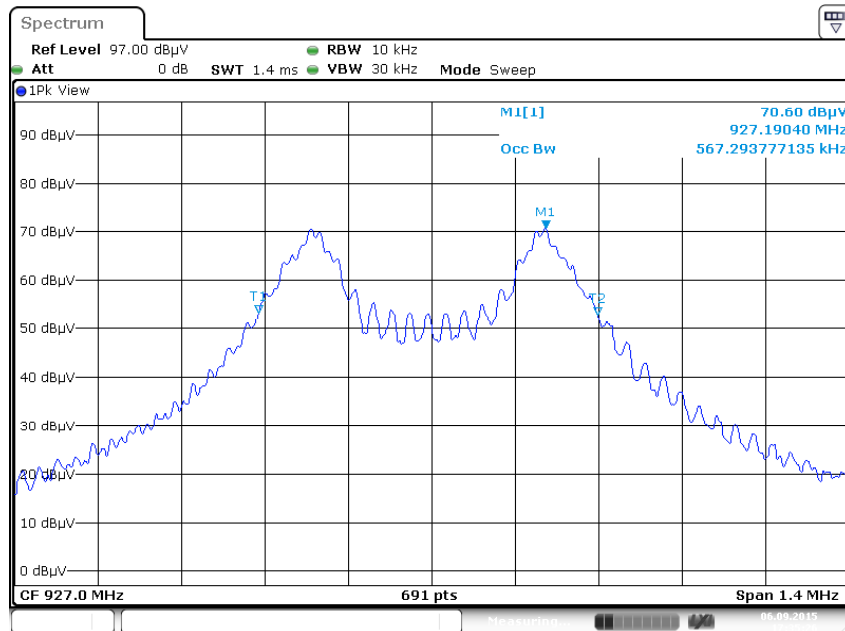

4.4. Radiated Emissions Measurement

4.4.1. Limit

30dBc in any 100 kHz bandwidth outside the operating frequency band. In case the emission fall within the restricted band specified on 15.205(a), then the 15.209(a) limit in the table below has to be followed.

Frequencies (MHz)	Field Strength (micorvolts/meter)	Measurement Distance (meters)
0.009~0.490	2400/F(kHz)	300
0.490~1.705	24000/F(kHz)	30
1.705~30.0	30	30
30~88	100	3
88~216	150	3
216~960	200	3
Above 960	500	3

4.4.2. Measuring Instruments and Setting

Please refer to section 5 of equipments list in this report. The following table is the setting of spectrum analyzer and receiver.

Spectrum Parameter	Setting
Attenuation	Auto
Start Frequency	1000 MHz
Stop Frequency	10th carrier harmonic
RBW / VBW (Emission in restricted band)	1MHz / 3MHz for Peak, 1MHz / 1/T for Average

Receiver Parameter	Setting
Attenuation	Auto
Start ~ Stop Frequency	9kHz~150kHz / RB 200Hz for QP
Start ~ Stop Frequency	150kHz~30MHz / RB 9kHz for QP
Start ~ Stop Frequency	30MHz~1000MHz / RB 120kHz for QP

4.4.3. Test Procedures

1. Configure the EUT according to ANSI C63.10. The EUT was placed on the top of the turntable 1.5 meter above ground. The phase center of the receiving antenna mounted on the top of a height-variable antenna tower was placed 1m & 3m far away from the turntable.
2. Power on the EUT and all the supporting units. The turntable was rotated by 360 degrees to determine the position of the highest radiation.
3. The height of the broadband receiving antenna was varied between one meter and four meters above ground to find the maximum emissions field strength of both horizontal and vertical polarization.
4. For each suspected emissions, the antenna tower was scan (from 1 m to 4 m) and then the turntable was rotated (from 0 degree to 360 degrees) to find the maximum reading.
5. Set the test-receiver system to Peak or CISPR quasi-peak Detect Function with specified bandwidth under Maximum Hold Mode.
6. For emissions above 1GHz, use 1MHz RBW and 3MHz VBW for peak reading. Then 1MHz RBW and 1/T VBW for average reading in spectrum analyzer.
7. If the emissions level of the EUT in peak mode was 3 dB lower than the average limit specified, then testing will be stopped and peak values of EUT will be reported, otherwise, the emissions which do not have 3 dB margin will be repeated one by one using the quasi-peak method for below 1GHz.
8. For testing above 1GHz, the emissions level of the EUT in peak mode was lower than average limit (that means the emissions level in peak mode also complies with the limit in average mode), then testing will be stopped and peak values of EUT will be reported, otherwise, the emissions will be measured in average mode again and reported.
9. In case the emission is lower than 30MHz, loop antenna has to be used for measurement and the recorded data should be QP measured by receiver. High – Low scan is not required in this case.

4.4.4. Test Setup Layout

For Radiated Emissions: 9kHz ~30MHz

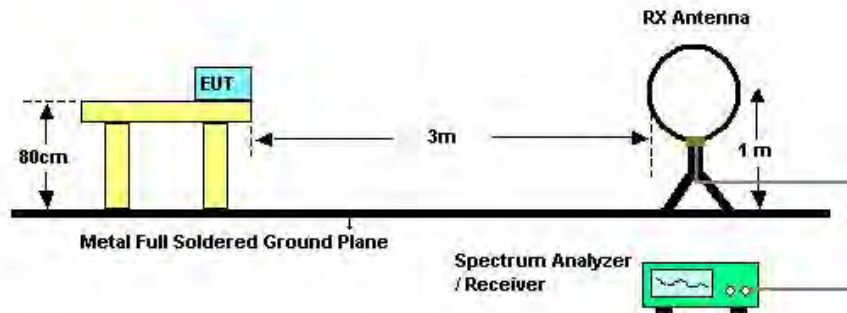

For Radiated Emissions: 30MHz~1GHz

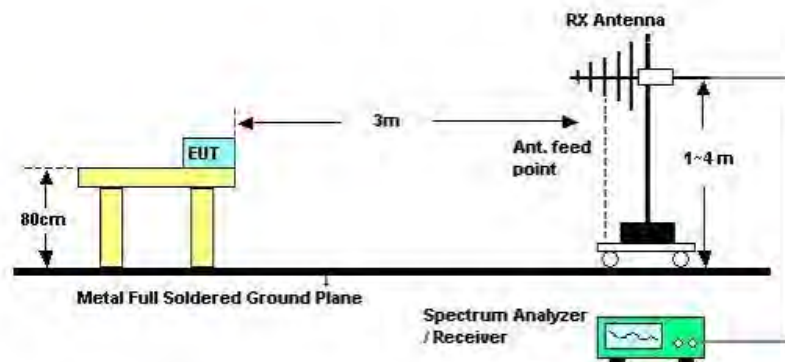

For Radiated Emissions: Above 1GHz

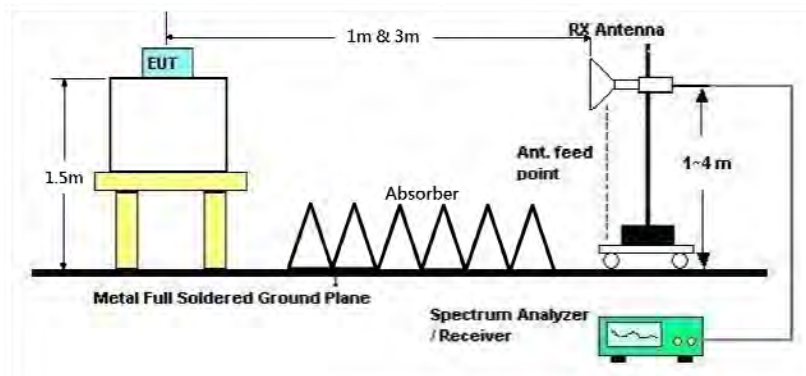

4.4.5. Test Deviation

There is no deviation with the original standard.

4.4.6. EUT Operation during Test

The EUT was programmed to be in continuously transmitting mode.

4.4.7. Results of Radiated Emissions (9kHz~30MHz)

Temperature	25°C	Humidity	60%
Test Engineer	Owen Hsu	Configurations	Normal Link
Test Date	Sep. 03, 2015	Test Mode	Mode 1

Freq. (MHz)	Level (dBuV)	Over Limit (dB)	Limit Line (dBuV)	Remark
-	-	-	-	See Note

Note:

The amplitude of spurious emissions that are attenuated by more than 20 dB below the permissible value has no need to be reported.

Distance extrapolation factor = $40 \log(\text{specific distance} / \text{test distance})$ (dB);

Limit line = specific limits (dBuV) + distance extrapolation factor.

4.4.8. Results of Radiated Emissions (30MHz~1GHz)

Temperature	25°C	Humidity	60%
Test Engineer	Owen Hsu	Configurations	Normal Link
Test Mode	Mode 1		

Horizontal

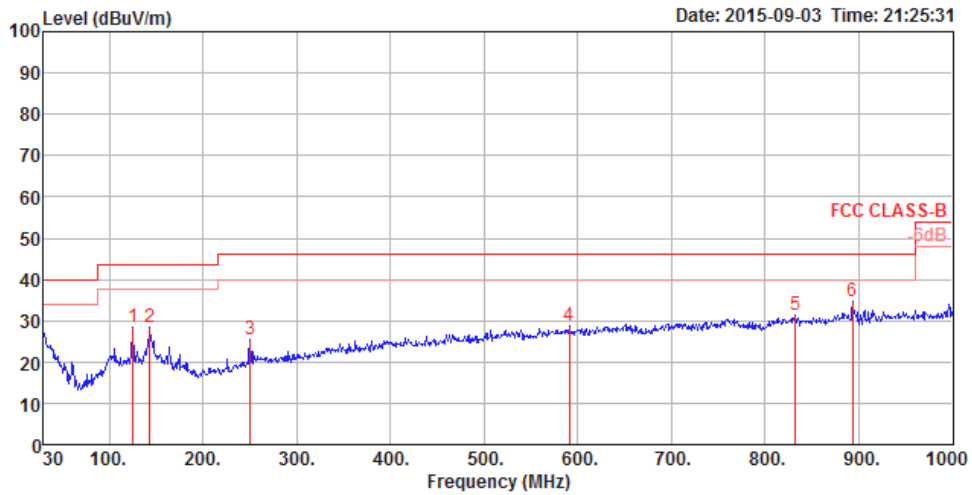

	Freq	Level	Limit	Over	Read	CableAntenna	Preamp	A/Pos	T/Pos	Remark	Pol/Phase	
	MHz	dBuV/m	dBuV/m	dB	dBuV	dB	dB/m	dB	cm	deg		
1	125.06	28.34	43.50	-15.16	46.92	1.04	12.75	32.37	150	310	Peak	HORIZONTAL
2	143.49	28.53	43.50	-14.97	48.03	1.08	11.78	32.36	150	358	Peak	HORIZONTAL
3	250.19	25.40	46.00	-20.60	43.42	1.38	12.90	32.30	100	337	Peak	HORIZONTAL
4	590.66	28.92	46.00	-17.08	40.25	2.05	19.03	32.41	150	298	Peak	HORIZONTAL
5	832.19	31.27	46.00	-14.73	39.88	2.34	21.13	32.08	150	26	Peak	HORIZONTAL
6	893.30	34.60	46.00	-11.40	42.31	2.42	21.65	31.78	100	340	Peak	HORIZONTAL

Vertical

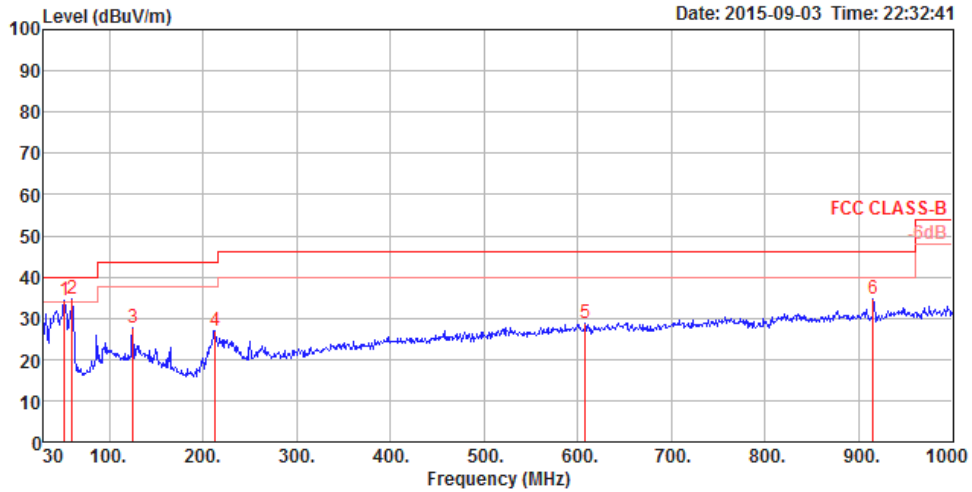

	Freq	Level	Limit	Over	Read	CableAntenna	Preamp	A/Pos	T/Pos	Remark	Pol/Phase
	MHz	dBuV/m	dBuV/m	dB	dBuV	dB	dB/m	dB	cm	deg	
1	52.31	34.19	40.00	-5.81	57.39	0.73	8.48	32.41	100	231	Peak VERTICAL
2	60.07	34.54	40.00	-5.46	59.27	0.77	6.90	32.40	100	240	Peak VERTICAL
3	125.06	27.69	43.50	-15.81	46.27	1.04	12.75	32.37	100	18	Peak VERTICAL
4	213.33	27.07	43.50	-16.43	47.33	1.29	10.77	32.32	150	178	Peak VERTICAL
5	608.12	28.94	46.00	-17.06	40.09	2.07	19.19	32.41	200	135	Peak VERTICAL
6	915.61	34.59	46.00	-11.41	41.92	2.45	21.80	31.58	150	6	Peak VERTICAL

Note:

The amplitude of spurious emissions that are attenuated by more than 20dB below the permissible value has no need to be reported.

Emission level (dBuV/m) = 20 log Emission level (uV/m).

Corrected Reading: Antenna Factor + Cable Loss + Read Level - Preamp Factor = Level.

4.4.9. Results for Radiated Emissions (1GHz~10th Harmonic)

For Ant. 1 (PIFA):

Temperature	25°C	Humidity	60%
Test Engineer	Owen Hsu	Configurations	2FSK / CH1 / 903 MHz
Test Date	Sep. 23, 2015		

Horizontal

	Freq	Level	Limit	Over	Read	Cable	Antenna	Preamp	T/Pos	A/Pos	Remark	Pol/Phase
	MHz	dBuV/m	dBuV/m	dB	dBuV	Loss	Factor	Factor	deg	cm		
1	2709.48	41.11	74.00	-32.89	43.20	4.02	28.52	34.63	236	127	Peak	HORIZONTAL
2	2709.48	32.11	54.00	-21.89	34.20	4.02	28.52	34.63	236	127	Average	HORIZONTAL

Vertical

	Freq	Level	Limit	Over	Read	Cable	Antenna	Preamp	T/Pos	A/Pos	Remark	Pol/Phase
	MHz	dBuV/m	dBuV/m	dB	dBuV	Loss	Factor	Factor	deg	cm		
1	2709.12	27.97	54.00	-26.03	30.06	4.02	28.52	34.63	203	174	Average	VERTICAL
2	2709.35	40.84	74.00	-33.16	42.93	4.02	28.52	34.63	203	174	Peak	VERTICAL

Temperature	25°C	Humidity	60%
Test Engineer	Owen Hsu	Configurations	2FSK / CH4 / 915 MHz
Test Date	Sep. 23, 2015		

Horizontal

	Freq	Level	Limit	Over	Read	Cable	Antenna	Preamp	T/Pos	A/Pos	Remark	Pol/Phase
	MHz	dBuV/m	dBuV/m	dB	dBuV	dB	dB/m	dB	deg	cm		
1	2745.69	35.27	54.00	-18.73	37.26	4.05	28.60	34.64	231	109	Average	HORIZONTAL
2	2745.79	43.45	74.00	-30.55	45.44	4.05	28.60	34.64	231	109	Peak	HORIZONTAL

Vertical

	Freq	Level	Limit	Over	Read	Cable	Antenna	Preamp	T/Pos	A/Pos	Remark	Pol/Phase
	MHz	dBuV/m	dBuV/m	dB	dBuV	dB	dB/m	dB	deg	cm		
1	2745.08	47.36	74.00	-26.64	49.35	4.05	28.60	34.64	257	114	Peak	VERTICAL
2	2745.16	38.63	54.00	-15.37	40.62	4.05	28.60	34.64	257	114	Average	VERTICAL

Temperature	25°C	Humidity	60%
Test Engineer	Owen Hsu	Configurations	2FSK / CH8 / 927 MHz
Test Date	Sep. 23, 2015		

Horizontal

	Freq	Level	Limit Line	Over Limit	Read Level	Cable Loss	Antenna Factor	Preamp Factor	T/Pos	A/Pos	Remark	Pol/Phase
	MHz	dBuV/m	dBuV/m	dB	dBuV	dB	dB/m	dB	deg	cm		
1	2781.60	44.07	74.00	-29.93	45.97	4.08	28.68	34.66	305	127	Peak	HORIZONTAL
2	2781.69	33.07	54.00	-20.93	34.97	4.08	28.68	34.66	305	127	Average	HORIZONTAL

Vertical

	Freq	Level	Limit Line	Over Limit	Read Level	Cable Loss	Antenna Factor	Preamp Factor	T/Pos	A/Pos	Remark	Pol/Phase
	MHz	dBuV/m	dBuV/m	dB	dBuV	dB	dB/m	dB	deg	cm		
1	2781.30	37.98	54.00	-16.02	39.88	4.08	28.68	34.66	205	173	Average	VERTICAL
2	2781.88	45.35	74.00	-28.65	47.25	4.08	28.68	34.66	205	173	Peak	VERTICAL

For Ant. 2 (Dipole Ant.):

Temperature	25°C	Humidity	60%
Test Engineer	Owen Hsu	Configurations	2FSK / CH1 / 903 MHz
Test Date	Sep. 23, 2015		

Horizontal

	Freq	Level	Limit	Over	Read	Cable	Antenna	Preamp	T/Pos	A/Pos	Remark	Pol/Phase
	MHz	dBuV/m	dBuV/m	dB	dBuV	dB	dB/m	dB	deg	cm		
1	2709.64	42.64	74.00	-31.36	44.73	4.02	28.52	34.63	254	133	Peak	HORIZONTAL
2	2709.98	33.64	54.00	-20.36	35.73	4.02	28.52	34.63	254	133	Average	HORIZONTAL

Vertical

	Freq	Level	Limit	Over	Read	Cable	Antenna	Preamp	T/Pos	A/Pos	Remark	Pol/Phase
	MHz	dBuV/m	dBuV/m	dB	dBuV	dB	dB/m	dB	deg	cm		
1	2709.55	35.64	54.00	-18.36	37.73	4.02	28.52	34.63	309	162	Average	VERTICAL
2	2709.81	43.64	74.00	-30.36	45.73	4.02	28.52	34.63	309	162	Peak	VERTICAL

Temperature	25°C	Humidity	60%
Test Engineer	Owen Hsu	Configurations	2FSK / CH4 / 915 MHz
Test Date	Sep. 23, 2015		

Horizontal

	Freq	Level	Limit Line	Over Limit	Read Level	Cable Loss	Antenna Factor	Preamp Factor	T/Pos	A/Pos	Remark	Pol/Phase
	MHz	dBuV/m	dBuV/m	dB	dBuV	dB	dB/m	dB	deg	cm		
1	2745.33	35.76	54.00	-18.24	37.75	4.05	28.60	34.64	241	129	Average	HORIZONTAL
2	2745.65	43.76	74.00	-30.24	45.75	4.05	28.60	34.64	241	129	Peak	HORIZONTAL

Vertical

	Freq	Level	Limit Line	Over Limit	Read Level	Cable Loss	Antenna Factor	Preamp Factor	T/Pos	A/Pos	Remark	Pol/Phase
	MHz	dBuV/m	dBuV/m	dB	dBuV	dB	dB/m	dB	deg	cm		
1	2745.65	46.76	74.00	-27.24	48.75	4.05	28.60	34.64	273	104	Peak	VERTICAL
2	2745.65	39.76	54.00	-14.24	41.75	4.05	28.60	34.64	273	104	Average	VERTICAL

Temperature	25°C	Humidity	60%
Test Engineer	Owen Hsu	Configurations	2FSK / CH8 / 927 MHz
Test Date	Sep. 23, 2015		

Horizontal

	Freq	Level	Limit Line	Over Limit	Read Level	Cable Loss	Antenna Factor	Preamp Factor	T/Pos	A/Pos	Remark	Pol/Phase
	MHz	dBuV/m	dBuV/m	dB	dBuV	dB	dB/m	dB	deg	cm		
1	2781.65	41.76	74.00	-32.24	43.66	4.08	28.68	34.66	322	127	Peak	HORIZONTAL
2	2781.65	32.76	54.00	-21.24	34.66	4.08	28.68	34.66	322	127	Average	HORIZONTAL

Vertical

	Freq	Level	Limit Line	Over Limit	Read Level	Cable Loss	Antenna Factor	Preamp Factor	T/Pos	A/Pos	Remark	Pol/Phase
	MHz	dBuV/m	dBuV/m	dB	dBuV	dB	dB/m	dB	deg	cm		
1	2781.18	38.57	54.00	-15.43	40.47	4.08	28.68	34.66	142	174	Average	VERTICAL
2	2781.86	46.25	74.00	-27.75	48.15	4.08	28.68	34.66	142	174	Peak	VERTICAL

Note:

The amplitude of spurious emissions that are attenuated by more than 20dB below the permissible value has no need to be reported.

Emission level (dBuV/m) = 20 log Emission level (uV/m).

Corrected Reading: Antenna Factor + Cable Loss + Read Level - Preamp Factor = Level.

4.5. Band Edge Emissions Measurement

4.5.1. Limit

30dBc in any 100 kHz bandwidth outside the operating frequency band. In case the emission fall within the restricted band specified on 15.205(a), then the 15.209(a) limit in the table below has to be followed.

Frequencies (MHz)	Field Strength (micorvolts/meter)	Measurement Distance (meters)
0.009~0.490	2400/F(kHz)	300
0.490~1.705	24000/F(kHz)	30
1.705~30.0	30	30
30~88	100	3
88~216	150	3
216~960	200	3
Above 960	500	3

4.5.2. Measuring Instruments and Setting

Please refer to section 5 of equipments list in this report. The following table is the setting of the spectrum analyzer.

Spectrum Parameter	Setting
Attenuation	Auto
Span Frequency	100 MHz
RBW / VBW (Emission in restricted band)	1 MHz / 3MHz for Peak, 1 MHz / 1/T for Average
RBW / VBW (Emission in non-restricted band)	100kHz / 300kHz for Peak

4.5.3. Test Procedures

For Radiated band edges Measurement:

1. The test procedure is the same as section 4.4.3.

For Radiated Out of Band Emission Measurement:

1. Test was performed in accordance with KDB558074 D01 v03r03 for Performing Compliance Measurements on Digital Transmission Systems (DTS) Operating Under §15.247 section 10.1 Unwanted Emissions into Non-Restricted Frequency Bands Measurement Procedure.

4.5.4. Test Setup Layout

For Radiated band edges Measurement:

This test setup layout is the same as that shown in section 4.4.4.

For Radiated Out of Band Emission Measurement:

This test setup layout is the same as that shown in section 4.4.4.

4.5.5. Test Deviation

There is no deviation with the original standard.

4.5.6. EUT Operation during Test

The EUT was programmed to be in continuously transmitting mode.

4.5.7. Test Result of Band Edge and Fundamental Emissions

For Emission not in Restricted Band

For Ant. 1 (PIFA Ant.):

Band Edge Plot on Configuration 2FSK / Reference Level

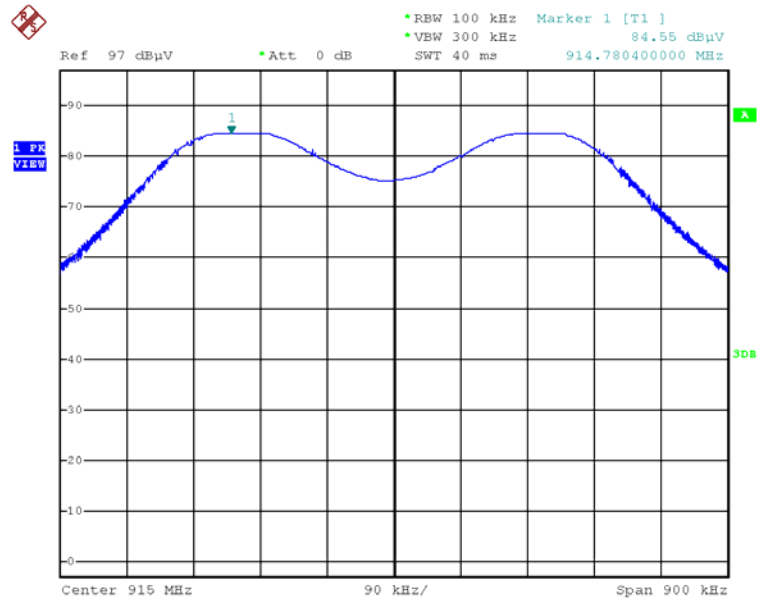

Date: 23.SEP.2015 22:27:48

Band Edge Plot on Configuration 2FSK / 903 MHz / 30MHz~902MHz (down 30dBc)

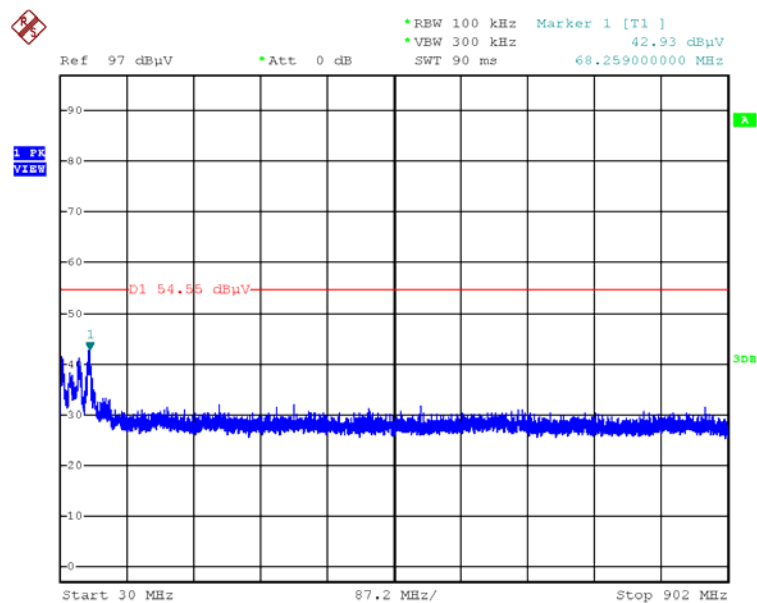

Date: 23.SEP.2015 22:33:34

Band Edge Plot on Configuration 2FSK / 903 MHz / 928MHz~1GHz (down 30dBc)

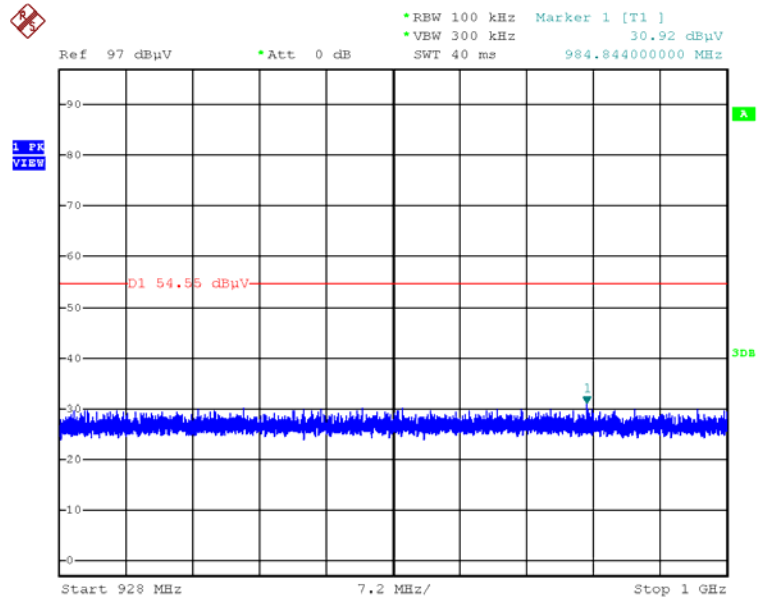

Date: 23.SEP.2015 22:34:20

Band Edge Plot on Configuration 2FSK / 903 MHz / 1GHz~10GHz (down 30dBc)

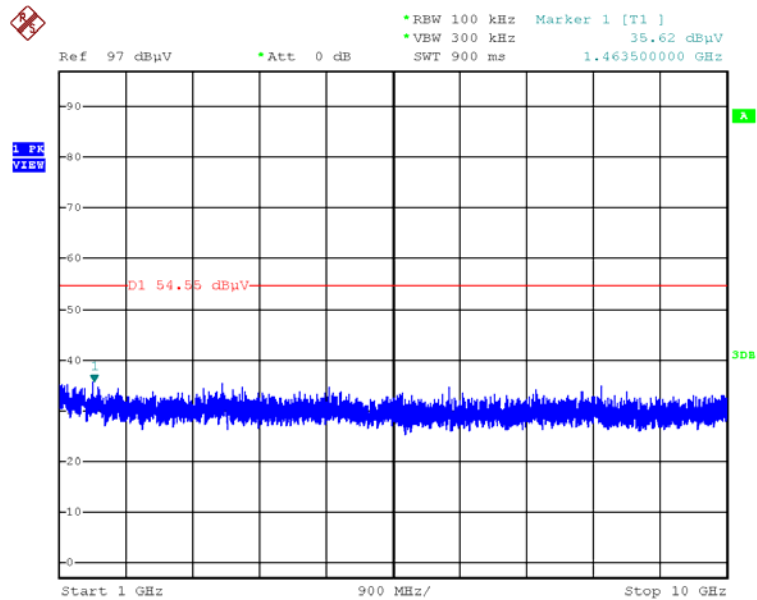

Date: 24.SEP.2015 02:01:52

Band Edge Plot on Configuration 2FSK / 927 MHz / 30MHz~902MHz (down 30dBc)

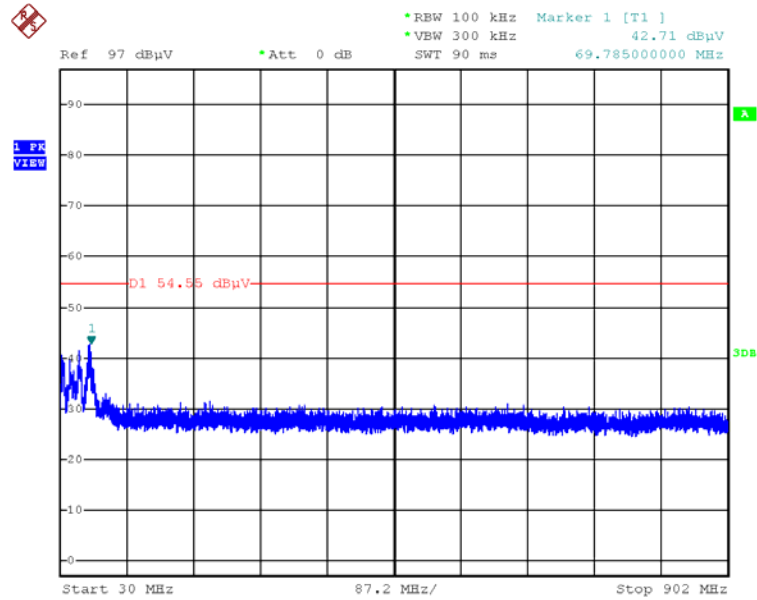

Date: 23.SEP.2015 22:37:57

Band Edge Plot on Configuration 2FSK / 927 MHz / 928MHz~1GHz (down 30dBc)

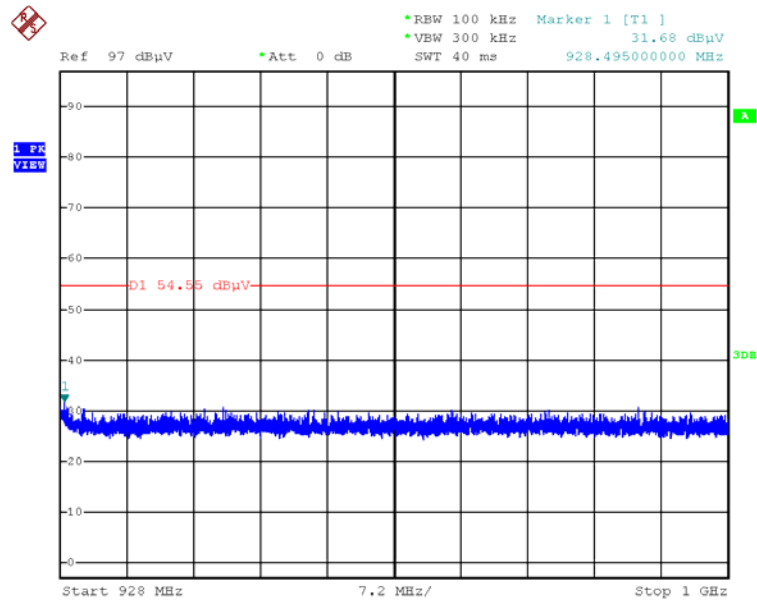

Date: 23.SEP.2015 22:37:17

Band Edge Plot on Configuration 2FSK / 927 MHz / 1GHz~10GHz (down 30dBc)

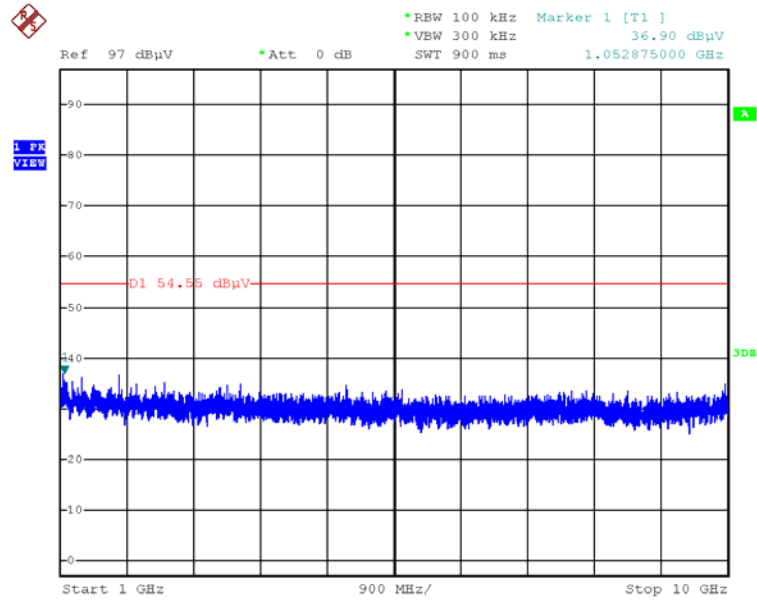

Date: 24.SEP.2015 02:03:37

For Ant. 2 (Dipole Ant.):

Band Edge Plot on Configuration 2FSK / Reference Level

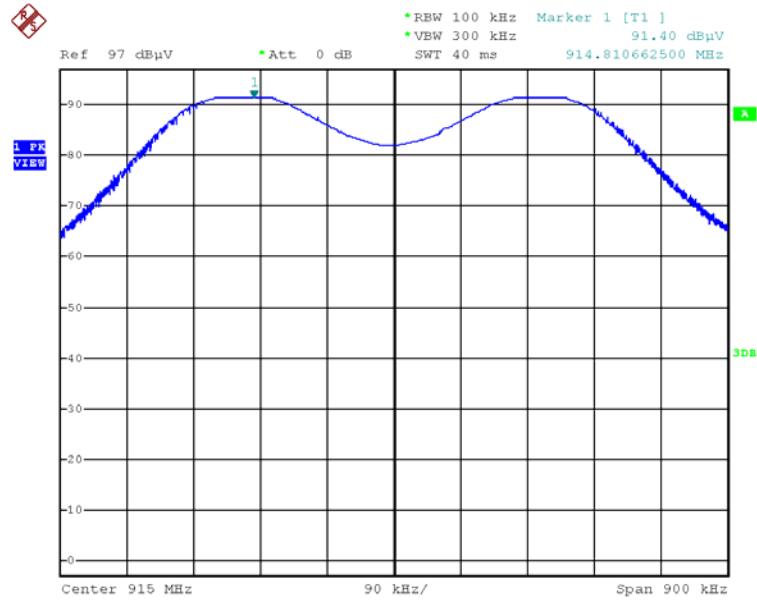

Date: 23.SEP.2015 22:04:18

Band Edge Plot on Configuration 2FSK / 903 MHz / 30MHz~902MHz (down 30dBc)

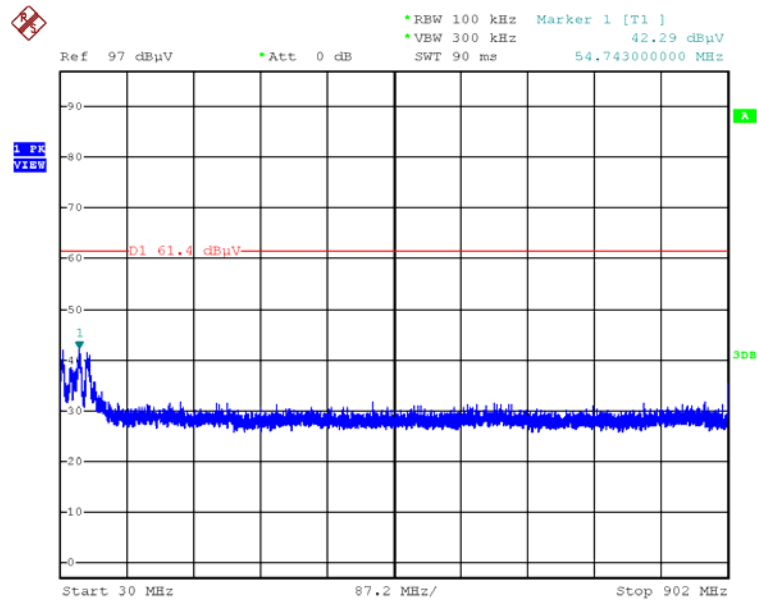

Date: 23.SEP.2015 22:13:24

Band Edge Plot on Configuration 2FSK / 903 MHz / 928MHz~1GHz (down 30dBc)

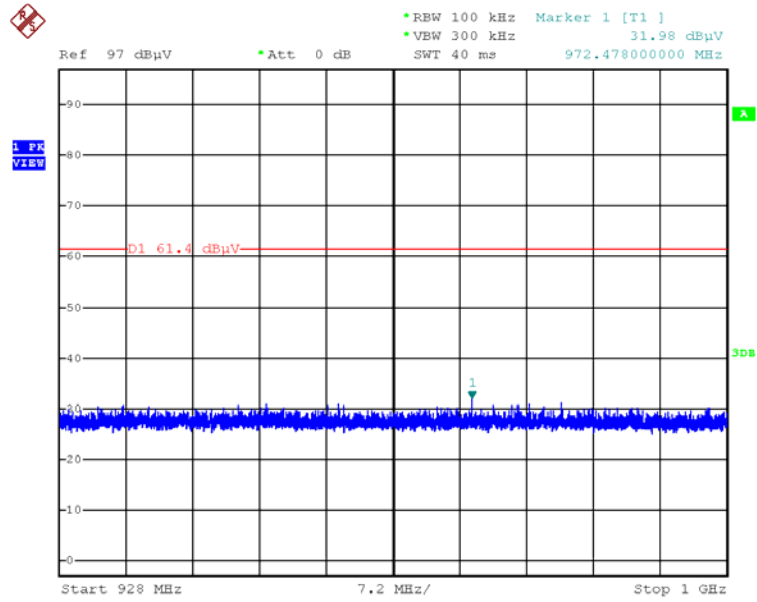

Date: 23.SEP.2015 22:14:51

Band Edge Plot on Configuration 2FSK / 903 MHz / 1GHz~10GHz (down 30dBc)

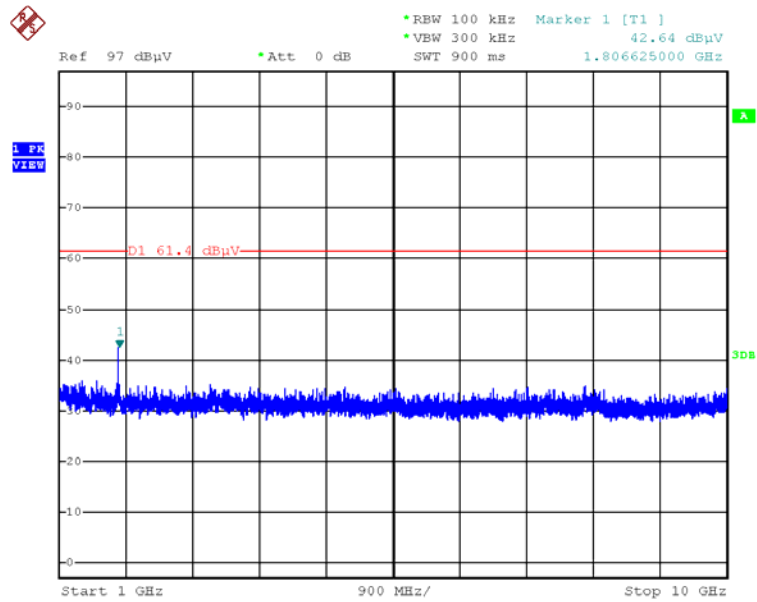

Date: 24.SEP.2015 01:52:51

Band Edge Plot on Configuration 2FSK / 927 MHz / 30MHz~902MHz (down 30dBc)

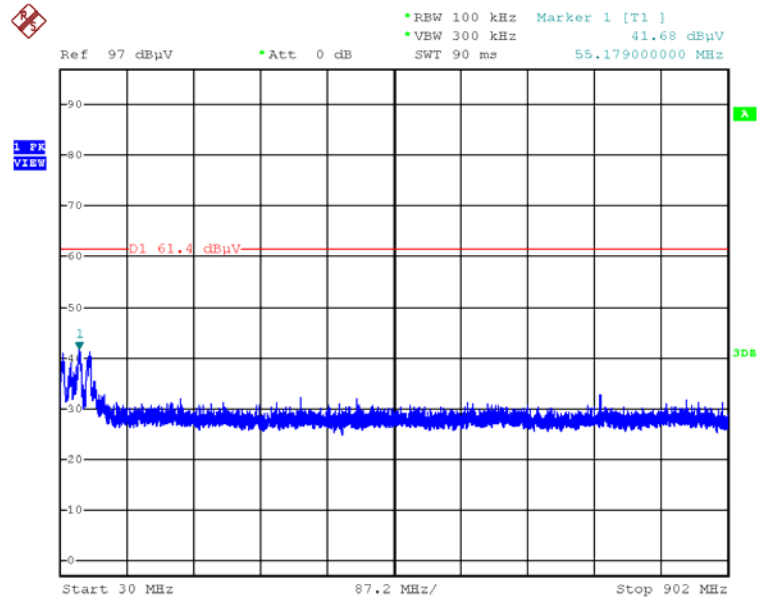

Date: 23.SEP.2015 22:18:27

Band Edge Plot on Configuration 2FSK / 927 MHz / 928MHz~1GHz (down 30dBc)

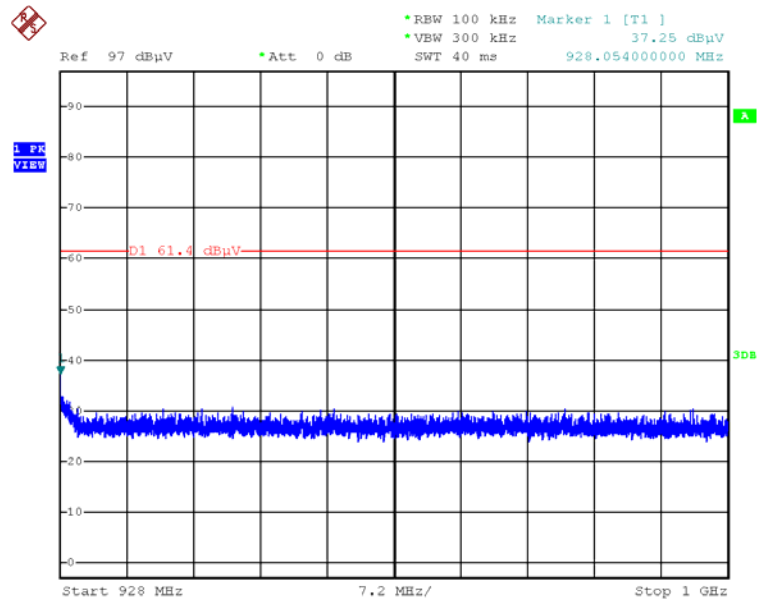

Date: 23.SEP.2015 22:19:41

Band Edge Plot on Configuration 2FSK / 927 MHz / 1GHz~10GHz (down 30dBc)

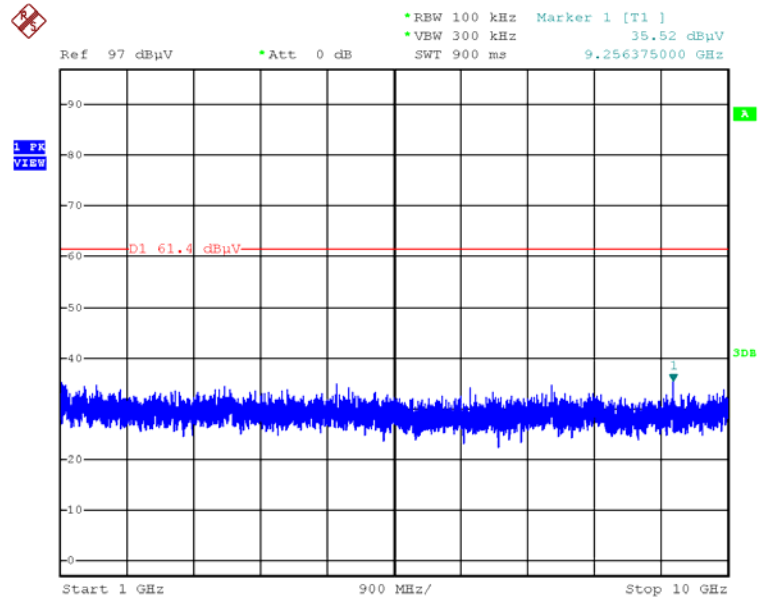

Date: 24.SEP.2015 02:00:16

4.6. Antenna Requirements

4.6.1. Limit

Except for special regulations, the Low-power Radio-frequency Devices must not be equipped with any jacket for installing an antenna with extension cable. An intentional radiator shall be designed to ensure that no antenna other than that furnished by the responsible party shall be used with the device. The use of a permanently attached antenna or of an antenna that uses a unique coupling to the intentional radiator shall be considered sufficient to comply with the provisions of this Section. The manufacturer may design the unit so that the user can replace a broken antenna, but the use of a standard antenna jack or electrical connector is prohibited. Further, this requirement does not apply to intentional radiators that must be professionally installed.

4.6.2. Antenna Connector Construction

Please refer to section 3.3 in this test report; antenna connector complied with the requirements.

5. LIST OF MEASURING EQUIPMENTS

Instrument	Manufacturer	Model No.	Serial No.	Characteristics	Calibration Date	Remark
BILOG ANTENNA	Schaffner	CBL6112D	22021	20MHz ~ 2GHz	May 06, 2015	Radiation (03CH01-CB)
Loop Antenna	Teseq	HLA 6120	24155	9kHz - 30 MHz	Mar. 12, 2015*	Radiation (03CH01-CB)
Horn Antenna	EMCO	3115	00075790	750MHz ~ 18GHz	Oct. 28, 2014	Radiation (03CH01-CB)
Pre-Amplifier	Agilent	8447D	2944A10991	0.1MHz ~ 1.3GHz	Feb. 24, 2015	Radiation (03CH01-CB)
Pre-Amplifier	Agilent	8449B	3008A02310	1GHz ~ 26.5GHz	Jan. 12, 2015	Radiation (03CH01-CB)
Spectrum Analyzer	R&S	FSP40	100056	9kHz ~ 40GHz	Nov. 06, 2014	Radiation (03CH01-CB)
EMI Receiver	Agilent	N9038A	MY52260123	9kHz ~ 8.4GHz	Jan. 21, 2015	Radiation (03CH01-CB)
RF Cable-low	Woken	Low Cable-1	N/A	30 MHz ~ 1 GHz	Nov. 15, 2014	Radiation (03CH01-CB)
RF Cable-high	Woken	High Cable-16	N/A	1 GHz ~ 18 GHz	Nov. 15, 2014	Radiation (03CH01-CB)
RF Cable-high	Woken	High Cable-17	N/A	1 GHz ~ 18 GHz	Nov. 15, 2014	Radiation (03CH01-CB)
Spectrum analyzer	R&S	FSP40	100979	9kHz~40GHz	Dec. 12, 2014	Conducted (TH01-CB)
RF Cable-high	Woken	RG402	High Cable-7	1 GHz – 26.5 GHz	Nov. 15, 2014	Conducted (TH01-CB)
RF Cable-high	Woken	RG402	High Cable-8	1 GHz – 26.5 GHz	Nov. 15, 2014	Conducted (TH01-CB)
RF Cable-high	Woken	RG402	High Cable-9	1 GHz – 26.5 GHz	Nov. 15, 2014	Conducted (TH01-CB)
RF Cable-high	Woken	RG402	High Cable-10	1 GHz – 26.5 GHz	Nov. 15, 2014	Conducted (TH01-CB)
RF Cable-high	Woken	RG402	High Cable-6	1 GHz – 26.5 GHz	Nov. 15, 2014	Conducted (TH01-CB)
Power Sensor	Agilent	U2021XA	MY53410001	50MHz~18GHz	Nov. 03, 2014	Conducted (TH01-CB)

Note: Calibration Interval of instruments listed above is one year.

“*” Calibration Interval of instruments listed above is two years.

6. MEASUREMENT UNCERTAINTY

Test Items	Uncertainty	Remark
Radiated Emission (30MHz ~ 1,000MHz)	3.6 dB	Confidence levels of 95%
Radiated Emission (1GHz ~ 18GHz)	3.7 dB	Confidence levels of 95%
Conducted Emission	1.7 dB	Confidence levels of 95%