



NEWTON LITE S-Label User Manual

NEWTON LITE S-Label (Electronic Shelf Label System)

REV1.0

(PMN :NEWTONLITE S-Label)

(FVIN : VERSION_ 6.0)

2020-05-111

SOLUM

Digital solution modules provider.

Summary

This datasheet presents the general performance and specifications of NEWTON LITE S-Label forESL (Electronic Shelf Label) System.

© SOLUM. All rights reserved

The names of actual companies and products mentioned herein may be the trademarks of their respective owners.

No part of this document may be reproduced, stored in a retrieval system, or transmitted in any form or by any means without the express written consent of SOLUM

This document is subject to change without notice.



Table of Contents

1	GENERAL DESCRIPTION	4
1.1	FEATURES	5
1.2	TYPICAL APPLICATIONS	5
1.3	APPEARANCE	5
2	SPECIFICATION	6
2.1	PRODUCT SPECIFICATION	6
2.2	RADIO (RF) SPECIFICATION	7
2.3	NFC SPECIFICATION	7
2.4	MECHANICAL DRAWING	8
2.5	LABEL MARKING	12
3	PACKAGING	13
4	CAUTIONS FOR TREATMENT	13
4.1	USAGE ENVIRONMENT	13
4.2	STORAGE AND USE	13
4.3	BATTERY REPLACEMENT	14
4.4	FCC	16



Document History

Rev.	Date	Revision History	Page
1.0	11MAY2020	Initial release	-

1 General Description

NEWTON LITE S-Label product is part of SoluM S-Label (Electronic Shelf Label) System, also consisting of NEWTON LITE S-Label Gateway (S-Gate), and Remote Controller (S-RC). The S-Label System electronically displays price, product, and promotion information on S-Labels, which has been traditionally printed or written on paper in places such as retail markets.

NEWTON LITE S-Label wirelessly receives data from S-Gate and updates the display with the new information provided.

NEWTON LITE S-Label is based BLE for low power wireless communication applications. It consists of RF transceiver, RF circuitry and ARM Cortex M3 MCU offering BLE based network protocol, and MAC protocol and other peripheral devices.

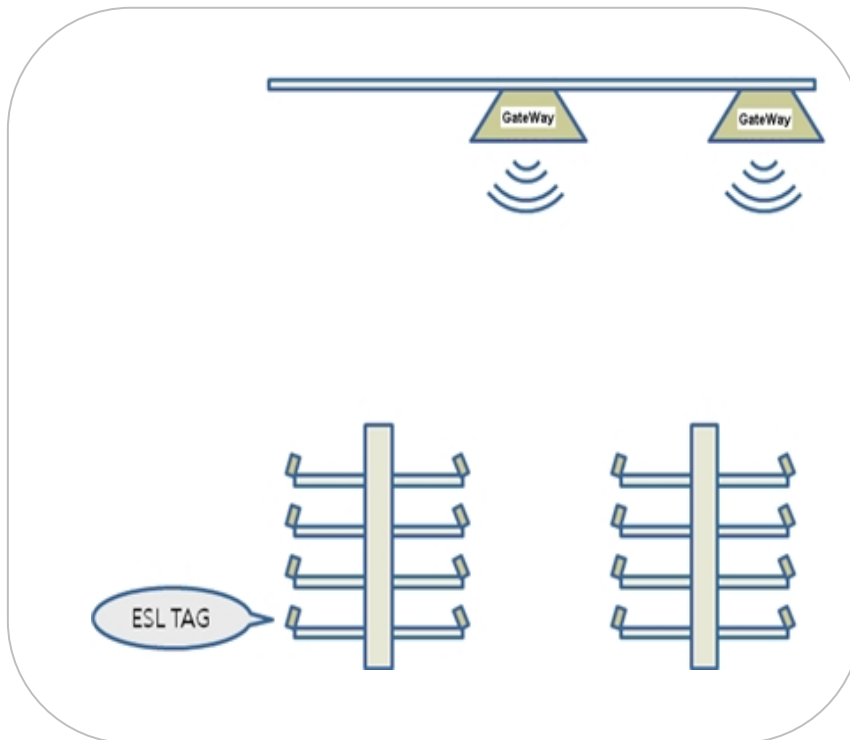

Figure 1.ESL System

1.1 Features

- Display: E-Paper Display (EPD)Active Type
(1.6",2.2",2.6, 2.9")
- Display Color: BWR(Black, White, Red) / BWY(Black, White, Yellow)
- Communication: Wireless communication based on BLE
- Operating on 2.4GHz Unlicensed ISM band for BLE
- Low Power Consumption
- Working Condition: Indoor where wireless communication is available.
- RoHS compliant
- NFC (13.56MHz): Felica ® NFC Forum Type 3

1.2 Typical Applications

- Retail industry with electronic displays, platforms, solutions and services.
- Intelligently communicating, managing, and optimizing price and product informations.

1.3 Appearance

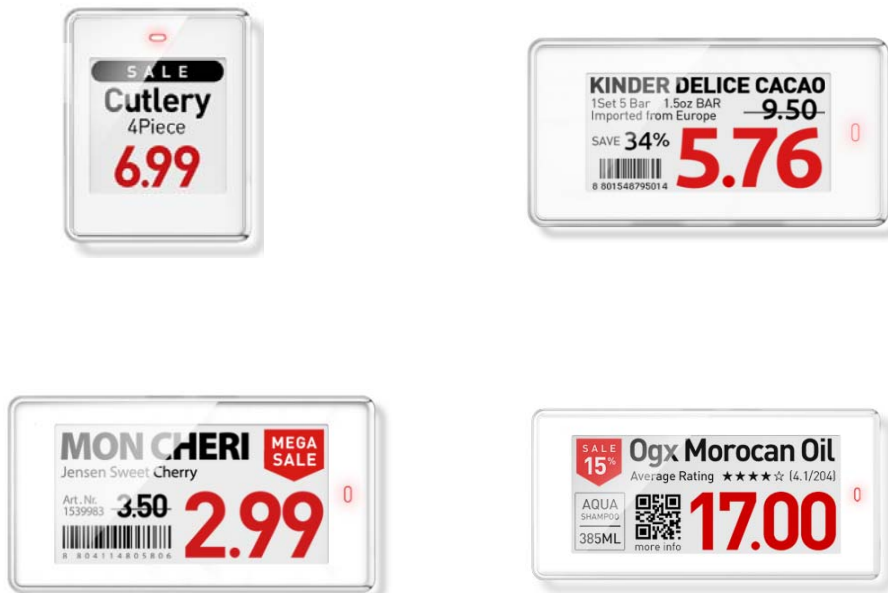

Figure 2.NEWTON S-Label

2 Specification

2.1 Product Specification

Item	Description
Size	1.6 Inch: 36.08 x 46.74x 13.35 2.2 Inch: 71.18 x 37.14x 13.35 2.6 Inch: 80.26 x 43 x 13.37 2.9 Inch: 87.46 x 43 x 13.35
Battery	CR2450 Lithium Battery (3V, 1PCS) 2.4 ~ 3.3Vdc(condition: In active status) ** Note: Battery capacity depends on temperature(especially in low temp environment) and number of update count.
Display	BW(Black, White) / BWR(Black, White, Red) / BWY(Black, White, Yellow) 1.6 Inch: 200 x 200 Pixel (184dpi) / 27.0 x 27.0mm 2.2 Inch: 250 x 122 Pixel (130dpi) / 48.55 x 23.7mm 2.6 Inch: 360 x 184 Pixel (152dpi) / 60.1 x 30.7mm 2.9 Inch: 384 x 168 Pixel (144dpi) / 67.6 x 29.6 mm
Housing Color	White
Information display	Price, Unit, Symbol etc.
Communication	Wireless communication based on 2.4GHz Unlicensed ISM band for BLE
Communication Distance	Radius30m
Operation Temperature	Normal Temperature TAG 0 ~ 40°C (@35~60% RH)
Storage Temp.	-20°C ~ 40°C

2.2 Radio(RF) Specification

Item	Parameter	SPEC			Unit	Condition
		Min	Typ	Max		
TX	Transmit Power	-3	0	4	dBm	
	[Carrier Frequency Offset and Drift]	-75	0	75	kHz	
	Tx Current		-	8	mA	Total current at max Tx Power
RX	Receiver Sensitivity	-85	-	-	dBm	PER < 5%

2.3 NFC Specification

Item	Parameter	SPEC			Unit	Condition
		Min	Typ	Max		
NFC	Read Distance	-	10	-	mm	TAG status

2.4 Mechanical Drawing

2.4.1 Case Dimension

- 1.6" Model

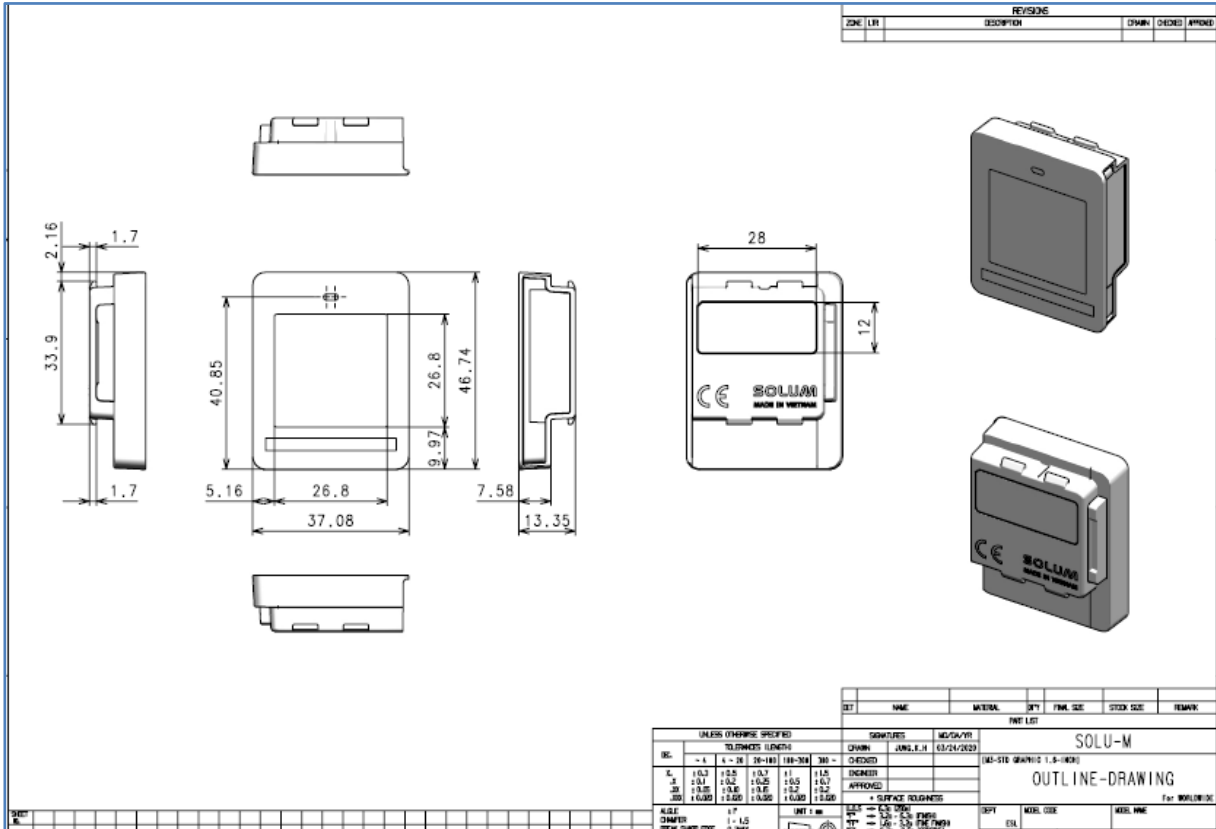

Figure 3. 1.6" Mechanical Dimension

- 2.2" Model

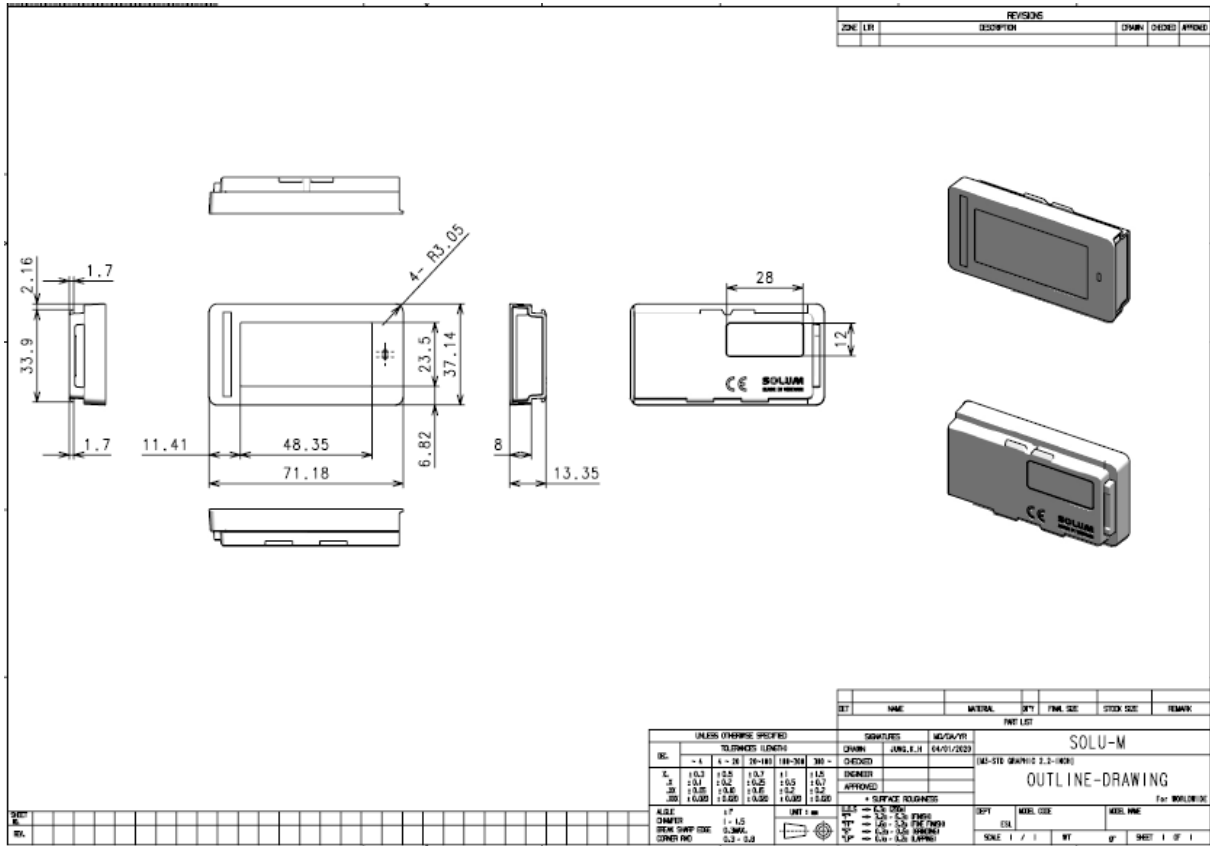

Figure 4.2.2" Mechanical Dimension

- 2.6" Model

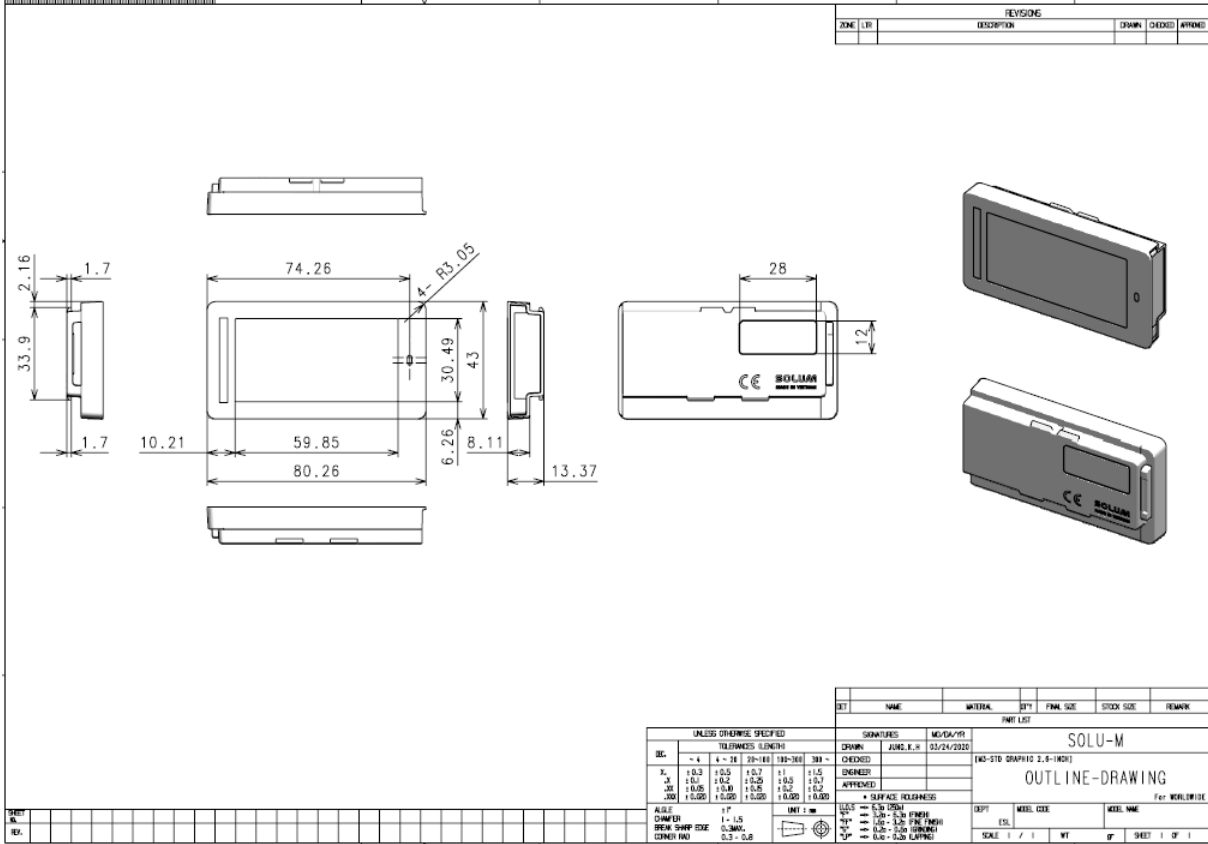

Figure 5. 2.6" Mechanical Dimension

- 2.9" Model

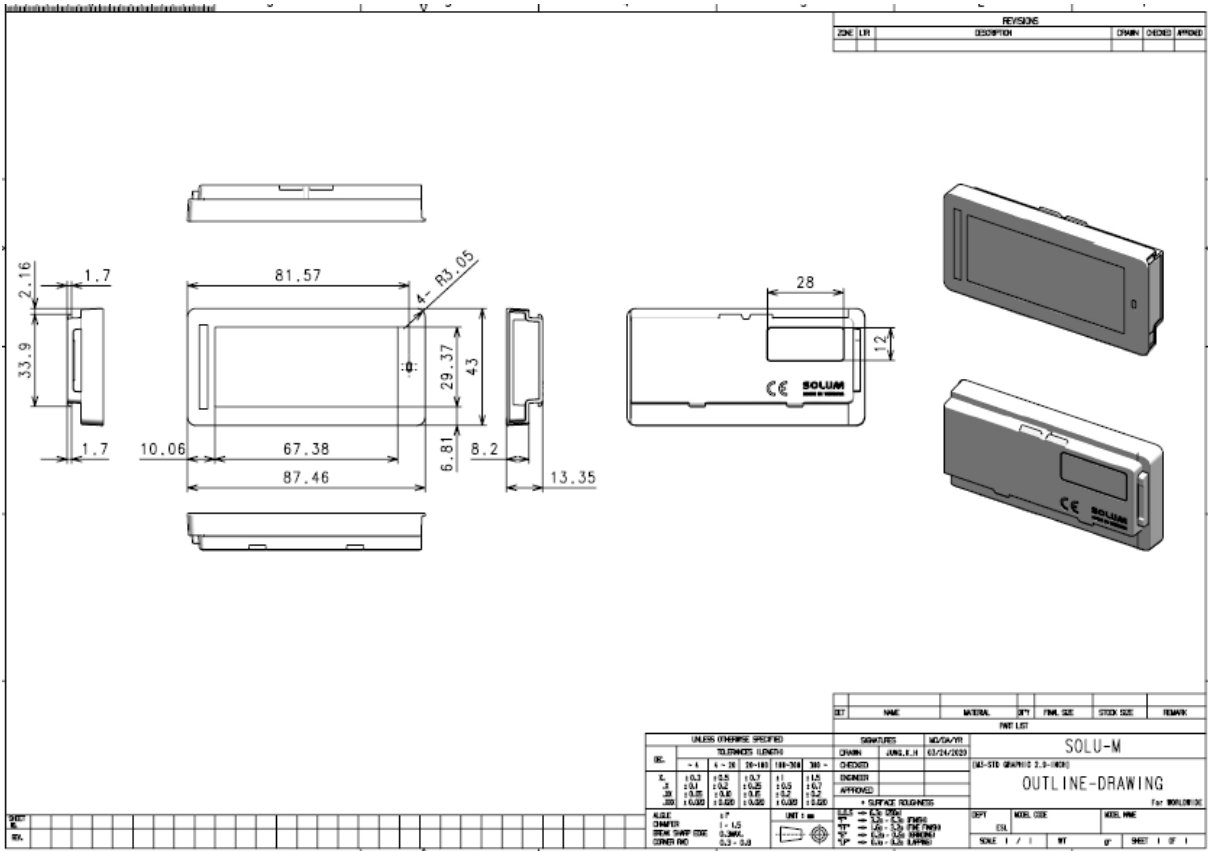

Figure 6. 2.9" Mechanical Dimension

2.5 Label Marking

2.5.1 Product Info and MAC Display in S-Label

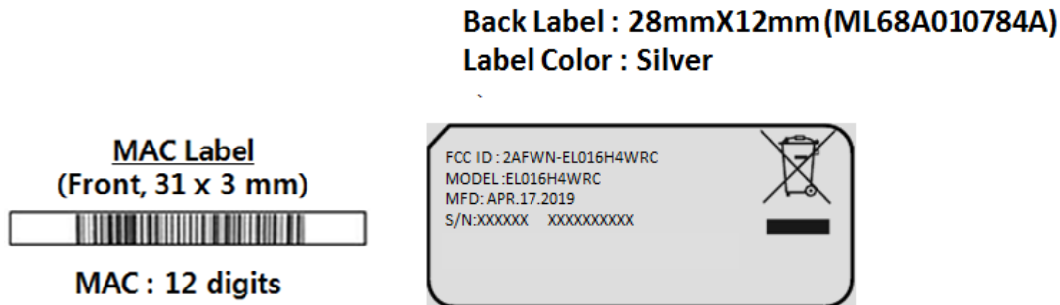

Figure 13.Product and MAC Labels

Product information is indicated on the sticker label of the S-Labels. The information is consisted of MODEL (model name), MFD (manufacturing date), S/N (serial number), MAC (MAC address), CE certification mark, FCC ID and Manufacturer (Solum).

1) Model Name: EL-①②③**H4**④⑤⑥ (i.e.EL016H4WRC)

- EL: TAG

- ①②③: Tag Display size

016=1.6"

029=2.9"

- ④: Tag Case Color

W - WHITE

B – BLACK

- ⑤ Tag Display-Color

M - Mono Tag (BW)

R - Red Color Tag (BWR)

Y - Yellow Color (BWY)

- ⑥: Tag Type (NFC, LED, etc)

2) MFD: (Month).(Date).(Year) i.e.JAN.26.2020

3) S/N: Serial Number Information (See Section 2.5.1)



3 Cautions for Treatment

Provisions should be made to protect against any damage to the product caused by improper handling. The purchaser assumes any responsibility for damage to the product caused by improper handling.

It is highly recommended that the product should be installed within 3 months from the date of arrival in the logistics hub. Recommended storage condition is -20~40 Celsius degree, 35-60% RH environment.

3.1 Usage Environment

Take extra cautions when using this RF device in the vicinity of other electronic devices and appliances. Most electronic devices and appliances use electromagnetic waves. Electromagnetic waves emitted by this RF device can affect other electronic devices and appliances.

If using the device in an explosion hazard area, follow all safety regulations, instructions, and signals.

3.2 Storage and Use

- Moisture and liquids can damage internal parts and circuit boards if allowed to enter into the device itself.
- Do not place or store the product on a sloped surface. The product may slide and fall off the surface and damaged.
- Use the product in temperatures ranging from 0°C to +30°C. Parts and circuits may be damaged if operating or stored in extreme temperature.
- The display panel needs extra care when handling.
 - Do not apply any impacts on the e-Paper display as it is fragile.
 - Continuous exposure to excessive moisture (over 60% RH) or UV shortens display lifetime.
 - Ghosting image may appear in temperature conditions of less than 15 Celsius degree.
- Avoid areas with strong magnetism or subject to magnetism.

Contact between the device and a magnetic object can lead to malfunctions.
- Do not place the product near heat-producing kitchen appliances like a stove or a microwave or in the vicinity of highly pressurized containers.
- External impact to the product, such as from being dropped, can damage the product.
- Twisting and bending the product can damage the exterior casing and the internal components.
- If this product operates abnormally while removing battery or replacing battery, the product



should be discharged by contacting the battery terminals (+) and (-) in the product.

- This product uses 2.4GHz frequency band for wireless communication network. Radio communications can be limited or affected by other applications that share the same frequency band, such as WiFi, Bluetooth, Zigbee, etc.
- Frequent communications, updates and screen renewals may reduce battery life time.
- Low temperature environments may reduce battery life.

3.3 Battery Replacement

Audience

- Authorized persons with the following knowledge are allowed to replace the battery:

Battery / Electronic assemblies like circuit board / Compliance of the instruction

※ Note: Warranty is voided if battery is replacement by unauthorized personnel.

(When replacing batteries, please contact authorized person)

Instructions

- Risk of short circuit if battery is incorrectly installed/stored.
 - Check that your hands are dry before and at all times during the replacement process.
 - Keep batteries away from children and infants.
- Do not heat, charge, bend, drop, short-circuit and/or disassemble battery.
- Do not mix used and new battery together or different battery types.
- ※ Note: Battery rarely has minor stain or leak.

Steps

- ① Open the battery cover.
- ② Take out the batteries.
- ③ Put in the new batteries.
- ④ Check the batteries direction.
- ⑤ Put the battery cover back.

Battery Directional

Top: (+) Positive

Bottom: (-) Negative

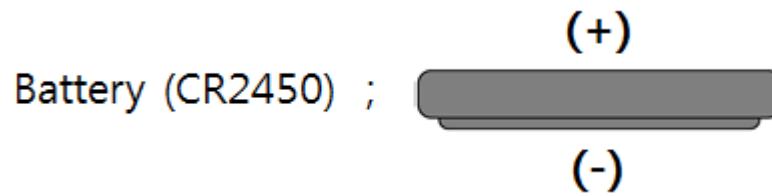

Figure 15. Battery Directional



3.4 FCC

WARNING: This equipment may generate or use radio frequency energy. Changes or modifications to this equipment may cause harmful interference unless the modifications are expressly approved in the instruction manual. The user could lose the authority to operate this equipment if an unauthorized change or modification is made.

This device complies with part 15 of the FCC Rules. Operation is subject to the following two conditions: (1) This device may not cause harmful interference, and (2) this device must accept any interference received, including interference that may cause undesired operation.

[RF exposure]

This equipment complies with the FCC RF radiation exposure limits set forth for an uncontrolled environment.

It should be installed and operated with a minimum distance of 20cm between the radiator and any part of your body

NOTE: This equipment has been tested and found to comply with the limits for a Class B digital device, pursuant to part 15 of the FCC Rules. These limits are designed to provide reasonable protection against harmful interference in a residential installation. This equipment generates, uses and can radiate radio frequency energy and, if not installed and used in accordance with the instructions, may cause harmful interference to radio communications. However, there is no guarantee that interference will not occur in a particular installation. If this equipment does cause harmful interference to radio or television reception, which can be determined by turning the equipment off and on, the user is encouraged to try to correct the interference by one or more of the following measures:

- Reorient or relocate the receiving antenna.
- Increase the separation between the equipment and receiver.
- Connect the equipment into an outlet on a circuit different from that to which the receiver is connected.
- Consult the dealer or an experienced radio/TV technician for help.



4 4.5 IC Information to User

This device complies with Industry Canada's licence-exempt RSSs. Operation is subject to the following two conditions:

(1) This device may not cause interference; and (2) This device must accept any interference, including interference that may cause undesired operation of the device

Le présent appareil est conforme aux CNR d'Industrie Canada applicables aux appareils radio exempts de licence. L'exploitation est autorisée aux deux conditions suivantes :

(1) l'appareil ne doit pas produire de brouillage, et (2) l'utilisateur de l'appareil doit accepter tout brouillage radioélectrique subi, même si le brouillage est susceptible d'en compromettre le fonctionnement.